



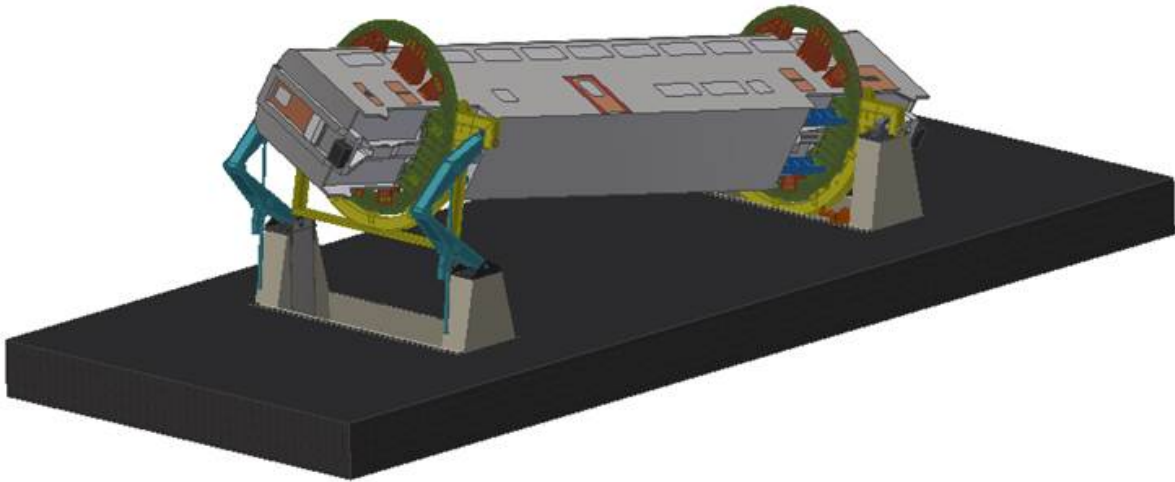
U.S. Department of  
Transportation

**Federal Railroad  
Administration**

## **Bi-Level Rollover Rig Design and Construction Estimate Final Report**

---

Office of Research  
Development  
and Technology  
Washington, DC 20590



#### NOTICE

This document is disseminated under the sponsorship of the Department of Transportation in the interest of information exchange. The United States Government assumes no liability for its contents or use thereof. Any opinions, findings and conclusions, or recommendations expressed in this material do not necessarily reflect the views or policies of the United States Government, nor does mention of trade names, commercial products, or organizations imply endorsement by the United States Government. The United States Government assumes no liability for the content or use of the material contained in this document.

#### NOTICE

The United States Government does not endorse products or manufacturers. Trade or manufacturers' names appear herein solely because they are considered essential to the objective of this report.

**REPORT DOCUMENTATION PAGE***Form Approved*  
*OMB No. 0704-0188*

Public reporting burden for this collection of information is estimated to average 1 hour per response, including the time for reviewing instructions, searching existing data sources, gathering and maintaining the data needed, and completing and reviewing the collection of information. Send comments regarding this burden estimate or any other aspect of this collection of information, including suggestions for reducing this burden, to Washington Headquarters Services, Directorate for Information Operations and Reports, 1215 Jefferson Davis Highway, Suite 1204, Arlington, VA 22202-4302, and to the Office of Management and Budget, Paperwork Reduction Project (0704-0188), Washington, DC 20503.

1. AGENCY USE ONLY (Leave blank)		2. REPORT DATE February 2021	3. REPORT TYPE AND DATES COVERED Technical Report 2006	
4. TITLE AND SUBTITLE Bi-Level Rollover Rig Design and Construction Estimate Final Report			5. FUNDING NUMBERS DTFR53-10-D-00002L TO0050	
6. AUTHOR(S) Jeffrey Bloom and Eric Sherrock				
7. PERFORMING ORGANIZATION NAME(S) AND ADDRESS(ES) ENSCO, Inc. Applied Technology and Engineering Division 5400 Port Royal Road Springfield, VA 22151			8. PERFORMING ORGANIZATION REPORT NUMBER	
9. SPONSORING/MONITORING AGENCY NAME(S) AND ADDRESS(ES) U.S. Department of Transportation Federal Railroad Administration Office of Railroad Policy and Development Office of Research, Development and Technology Washington, DC 20590			10. SPONSORING/MONITORING AGENCY REPORT NUMBER  DOT/FRA/ORD-21/10	
11. SUPPLEMENTARY NOTES COR: Melissa Shurland				
12a. DISTRIBUTION/AVAILABILITY STATEMENT This document is available to the public through the FRA <a href="#">website</a> .			12b. DISTRIBUTION CODE	
13. ABSTRACT (Maximum 200 words) In 2006, the Federal Railroad Administration (FRA) funded the development of the Passenger Rail Vehicle Emergency Evacuation Simulator, known as the "rollover rig." This device was constructed to provide the railroad passenger community with the training tools to respond effectively during a passenger train accident/derailment. It is a platform for different types of emergency response training and safety equipment that is evaluated by equipment designers. Four concepts of comparative evaluation were developed based on the need for the industry. This report describes the various elements of those concepts and offers guidance for the fabrication and drawings of its assembly, cost estimates, and the anticipated construction schedule.				
14. SUBJECT TERMS Washington Metropolitan Area Transit Authority, WMATA, rollover rig, bi-level, emergency egress, emergency response, training, emergency evacuation simulator			15. NUMBER OF PAGES 53	
			16. PRICE CODE	
17. SECURITY CLASSIFICATION OF REPORT Unclassified	18. SECURITY CLASSIFICATION OF THIS PAGE Unclassified	19. SECURITY CLASSIFICATION OF ABSTRACT Unclassified	20. LIMITATION OF ABSTRACT	

NSN 7540-01-280-5500

Standard Form 298 (Rev. 2-89)  
Prescribed by ANSI Std. Z39-18  
298-102

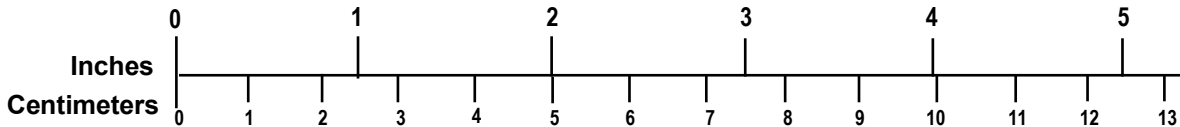
# METRIC/ENGLISH CONVERSION FACTORS

## ENGLISH TO METRIC

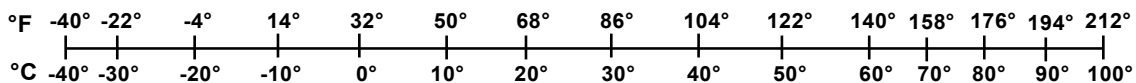
## METRIC TO ENGLISH

<p><b>LENGTH (APPROXIMATE)</b></p> <p>1 inch (in) = 2.5 centimeters (cm)                      1 foot (ft) = 30 centimeters (cm)                      1 yard (yd) = 0.9 meter (m)                      1 mile (mi) = 1.6 kilometers (km)</p>	<p><b>LENGTH (APPROXIMATE)</b></p> <p>1 millimeter (mm) = 0.04 inch (in)                      1 centimeter (cm) = 0.4 inch (in)                      1 meter (m) = 3.3 feet (ft)                      1 meter (m) = 1.1 yards (yd)                      1 kilometer (km) = 0.6 mile (mi)</p>
<p><b>AREA (APPROXIMATE)</b></p> <p>1 square inch (sq in, in<sup>2</sup>) = 6.5 square centimeters (cm<sup>2</sup>)                      1 square foot (sq ft, ft<sup>2</sup>) = 0.09 square meter (m<sup>2</sup>)                      1 square yard (sq yd, yd<sup>2</sup>) = 0.8 square meter (m<sup>2</sup>)                      1 square mile (sq mi, mi<sup>2</sup>) = 2.6 square kilometers (km<sup>2</sup>)                      1 acre = 0.4 hectare (he) = 4,000 square meters (m<sup>2</sup>)</p>	<p><b>AREA (APPROXIMATE)</b></p> <p>1 square centimeter (cm<sup>2</sup>) = 0.16 square inch (sq in, in<sup>2</sup>)                      1 square meter (m<sup>2</sup>) = 1.2 square yards (sq yd, yd<sup>2</sup>)                      1 square kilometer (km<sup>2</sup>) = 0.4 square mile (sq mi, mi<sup>2</sup>)                      10,000 square meters (m<sup>2</sup>) = 1 hectare (ha) = 2.5 acres</p>
<p><b>MASS - WEIGHT (APPROXIMATE)</b></p> <p>1 ounce (oz) = 28 grams (gm)                      1 pound (lb) = 0.45 kilogram (kg)                      1 short ton = 2,000 pounds (lb) = 0.9 tonne (t)</p>	<p><b>MASS - WEIGHT (APPROXIMATE)</b></p> <p>1 gram (gm) = 0.036 ounce (oz)                      1 kilogram (kg) = 2.2 pounds (lb)                      1 tonne (t) = 1,000 kilograms (kg)                      = 1.1 short tons</p>
<p><b>VOLUME (APPROXIMATE)</b></p> <p>1 teaspoon (tsp) = 5 milliliters (ml)                      1 tablespoon (tbsp) = 15 milliliters (ml)                      1 fluid ounce (fl oz) = 30 milliliters (ml)                      1 cup (c) = 0.24 liter (l)                      1 pint (pt) = 0.47 liter (l)                      1 quart (qt) = 0.96 liter (l)                      1 gallon (gal) = 3.8 liters (l)                      1 cubic foot (cu ft, ft<sup>3</sup>) = 0.03 cubic meter (m<sup>3</sup>)                      1 cubic yard (cu yd, yd<sup>3</sup>) = 0.76 cubic meter (m<sup>3</sup>)</p>	<p><b>VOLUME (APPROXIMATE)</b></p> <p>1 milliliter (ml) = 0.03 fluid ounce (fl oz)                      1 liter (l) = 2.1 pints (pt)                      1 liter (l) = 1.06 quarts (qt)                      1 liter (l) = 0.26 gallon (gal)                      1 cubic meter (m<sup>3</sup>) = 36 cubic feet (cu ft, ft<sup>3</sup>)                      1 cubic meter (m<sup>3</sup>) = 1.3 cubic yards (cu yd, yd<sup>3</sup>)</p>
<p><b>TEMPERATURE (EXACT)</b></p> <p><math>[(x-32)(5/9)] \text{ } ^\circ\text{F} = y \text{ } ^\circ\text{C}</math></p>	<p><b>TEMPERATURE (EXACT)</b></p> <p><math>[(9/5) y + 32] \text{ } ^\circ\text{C} = x \text{ } ^\circ\text{F}</math></p>

## QUICK INCH - CENTIMETER LENGTH CONVERSION



## QUICK FAHRENHEIT - CELSIUS TEMPERATURE CONVERSION



For more exact and or other conversion factors, see NIST Miscellaneous Publication 286, Units of Weights and Measures. Price \$2.50 SD Catalog No. C13 10286

Updated 6/17/98

# Contents

---

Executive Summary .....	1
1. Introduction .....	3
1.1 Background .....	4
1.2 Overall Approach .....	5
1.3 Organization of the Report .....	5
2. Vehicle and Site Selection.....	6
2.1 Vehicle Selection.....	6
2.2 Site Selection.....	6
3. Concept and Selection Process.....	8
3.1 Concept Development .....	8
3.2 Rotisserie on Bridge .....	8
3.3 Rotisserie on Earthworks.....	11
3.4 Hoops on Bridge.....	15
3.5 Hoops on Earthworks .....	18
3.6 Evaluation Criteria and Relative Weightings.....	21
4. Description of Rollover Rig Facility Design.....	25
5. Component Design Analysis .....	32
6. Cost Estimate for Facility Construction .....	38
7. Scheduling for Facility Construction.....	40
8. Drawing Lists .....	42
9. Conclusion.....	44
Abbreviations and Acronyms .....	45

## Illustrations

---

Figure 1. FRA-Sponsored Rollover Rig at WMATA Carmen E. Turner Training Center .....	4
Figure 2. Amtrak Superliner Coach.....	6
Figure 3. Amtrak’s Los Angeles Vehicle Maintenance Facility.....	7
Figure 4. Rotisserie on Bridge Design.....	8
Figure 5. Vehicle Lift Process for Rotisserie on Bridge Design.....	9
Figure 6. Rotisserie on Bridge Design Rolled and Tilted.....	10
Figure 7. End of Car Extension in Rotisserie on Bridge Design .....	10
Figure 8. Motor Drive for Rotation in Rotisserie on Bridge Design .....	11
Figure 9. Lift Arm Located Near Center Pivot Under Bridge in Rotisserie on Bridge Design....	11
Figure 10. Rotisserie on Earthworks Design .....	12
Figure 11. Rotisserie on Earthworks Design in Fully Raised Position.....	12
Figure 12. Rotisserie on Earthworks Design Using Loader Arms.....	13
Figure 13. Lifting and Rotating Systems in Lowered Position Showing Both Lift Devices, Rotisserie on Earthworks Design.....	14
Figure 14. Lifting and Rotating Systems in Raised Position Showing Both Lift Devices, Rotisserie on Earthworks Design.....	15
Figure 15. Hoops on Bridge Design .....	15
Figure 16. Lowered and Raised Vehicle in Hoops on Bridge Design .....	16
Figure 17. Lifted Vehicle in Hoops on Bridge Design.....	17
Figure 18. Lifted and Rolled Vehicle in Hoops on Bridge Design.....	17
Figure 19. Walking Beam.....	18
Figure 20. Push-Pull Winch.....	18
Figure 21. Hoops on Earthworks Design.....	19
Figure 22. Hoops on Earthworks Design in Lifted Position.....	19
Figure 23. Loader Arms Depicted in Lowered and Raised Positions for Hoops on Earthworks Design .....	20
Figure 24. Vehicle Lifted and Rolled to 90 Degrees in Hoops on Earthworks Design.....	20
Figure 25. Cradle and Hoop Assembly for Hoops on Earthworks Design.....	21
Figure 26. Walking Beam Assembly Used in Hoops on Earthworks Design .....	21
Figure 27. Final Design of Bi-Level Rollover Rig.....	25
Figure 28. Vehicle Shown in Normal Position .....	25
Figure 29. Cradle, Hoop and Walking Beams .....	26

Figure 30. Cradle Weldment.....	27
Figure 31. Hoop Assembly .....	28
Figure 32. Body Wall Anchor Sleeves .....	28
Figure 33. Loader Arms Used to Raise Vehicle .....	29
Figure 34. Concrete Pillars .....	30
Figure 35. Concrete Pillars, Slab and Side Walls .....	30
Figure 36. Reinforcement of Concrete Slab and Pillars .....	31
Figure 37. Push-Pull Winch Arrangement.....	31
Figure 38. Von Mises Stress Plot for Hoop .....	32
Figure 39. Constraint and Loading Plot for Hoop .....	33
Figure 40. Deformation Plot for Hoop.....	33
Figure 41. Constraints and Load Plot for Hoop.....	34
Figure 42. Von Mises Stress Plot for Cradle .....	35
Figure 43. Constraint and Loading Plot for Cradle .....	35
Figure 44. Deformation Plot for Cradle.....	36
Figure 45. Constraints and Load Plot for Hoop.....	37
Figure 46. Full Construction Schedule for Bi-Level Rollover Rig.....	41

## Tables

---

Table 1. Comparative Evaluation Criteria .....	21
Table 2. Comparative Evaluation of Four Concepts.....	23
Table 3. Cost Estimate for Construction of Bi-Level Rollover Rig .....	38
Table 4. Major Milestones Schedule .....	40
Table 5. Loading Arm Drawing List.....	42
Table 6. Hoop Drawing List .....	42
Table 7. Cradle Drawing List.....	42
Table 8. Vertical Walking Beam Drawing List .....	43
Table 9. Longitudinal Walking Beam Drawing List .....	43
Table 10. Concrete Foundation and Site Layout Drawing List .....	43



## **Executive Summary**

---

In 2006, the Federal Railroad Administration (FRA) developed the Passenger Rail Vehicle Emergency Evacuation Simulator, known as the “rollover rig,” with ENSCO, Inc. It was developed at the Washington Metropolitan Area Transit Authority’s (WMATA) Carmen E. Turner Training Center in Landover, MD. The rollover rig was constructed to provide the railroad passenger community with the following:

- A training tool for first responders to passenger train accidents/derailments
- A platform for equipment designers to evaluate different types of emergency equipment
- A tool used for evaluating the applicability of time-based egress computer models to passenger rail cars, and the possible refinement of such models

The device has been used to train thousands of emergency responders, including area fire fighters, paramedics, military personnel, and police in the evacuation of passengers from overturned rail cars.

Recent discussions between Amtrak and FRA confirmed that a rollover rig tailored for a bi-level passenger car would offer a significant benefit to passenger rail operations. Thus, FRA funded an effort to design a training facility built around a bi-level passenger rail car, while all project stakeholders explored funding options that can be used for the construction of the facility.

The requirements of the bi-level rollover rig, established by FRA and Amtrak, are as follows:

- Shall be capable of rotating 180 degrees in 10 degree increments
- Shall be capable of simulating smoke and dark conditions inside the rail car
- Shall be equipped with a video system that can capture the activities inside the rig during low/dark interior conditions and dense smoke conditions
- Shall be able to simulate a pile-up of rail cars by allowing for diagonal or one-sided jacking of the ends of the car

Four basic concepts for the rollover rig were developed based on two approaches to roll the vehicle and two approaches to raise one end of the vehicle. The two methods for rolling the vehicle relied on the use of hoops that encircle the vehicle or the use of rotation points on each end of the vehicle in a rotisserie fashion. The two methods to lift one end of the vehicle were to place the vehicle on a bridge-like structure or by use of jacks that lift one end of the vehicle from earthworks. The four concepts of the basic designs were developed and designated as:

1. Rotisserie on Bridge
2. Rotisserie on Earthworks
3. Hoops on Bridge
4. Hoops on Earthworks

A comparative evaluation of the four concepts was conducted utilizing a set of evaluation criteria selected to align with training requirements, cost limitations, and safety considerations of the facility. Each evaluation criteria were given a weight scale based on its overall importance. As a

result of the evaluation, the final design of the bi-level rollover rig was based on the Hoops on Earthworks concept.

This report describes the various elements of the candidate concepts as well as the design selected for implementation. In addition, the report provides guidance for the fabrication and assembly drawings, as well as rough order of magnitude construction cost estimates, and an anticipated construction schedule.

## 1. Introduction

---

In 2006, the Federal Railroad Administration (FRA) developed the Passenger Rail Vehicle Emergency Evacuation Simulator, known as the “rollover rig,” to provide the railroad passenger community with:

- A training tool for first responders to assist passenger train accidents/derailments
- A platform for equipment designers to evaluate different types of emergency equipment
- A tool to evaluate the applicability of time-based egress computer models to passenger rail cars and the possible refinement of such models

Figure 1 provides a visual of the rollover rig at the Washington Metropolitan Area Transit Authority’s (WMATA’s) Carmen E. Turner Training Center in Landover, MD.

The first rollover rig employed a New Jersey Transit Comet I single level rail passenger car with end vestibule side doors. The device could address several important industry needs; the most important is training during an overturned rail car incident. The requirements of the newly proposed bi-level rollover rig, established by FRA and Amtrak, are as follows:

- Shall utilize a bi-level passenger coach vehicle as its basis
- Shall be capable of rotating the vehicle 180 degrees in 10 degree increments
- Shall be capable of simulating smoke and dark conditions inside the rail car
- Shall be equipped with a video system that will be capable of capturing the activities inside the rig during low/dark interior conditions and dense smoke conditions
- Shall be able to simulate a pile-up of rail cars by allowing for diagonal or one-sided jacking of the ends of the car

ENSCO, Inc. has designed a facility within their Applied Technology and Engineering Division that meets the FRA requirements presented above to provide a realistic and safe environment to train first responders. This report presents this design as well as preliminary considerations for the eventual construction of the rollover rig.



**Figure 1. FRA-Sponsored Rollover Rig at WMATA Carmen E. Turner Training Center**

## **1.1 Background**

The U.S. rail industry is on the verge of experiencing the largest influx of new passenger rail equipment in recent history. Many agencies will be increasing their reliance on bi-level cars to maximize passenger capacity over the designated routes. It is anticipated by some in the industry that orders involving bi-level cars will increase as agencies around the country take advantage of the lower acquisition and maintenance costs associated with large quantities of common vehicles.

A bi-level rollover rig would address several important industry needs. The evacuation and rescue situations associated with bi-level cars can be more challenging than those of single level cars. The impending increase in the number of bi-level cars will not only require the railroad industry to be prepared for evacuation scenarios involving bi-level cars, but will also create the need to have a test platform for both evaluation of egress scenarios and general human factors studies.

Recent discussions between Amtrak and FRA have confirmed that a bi-level rollover rig serving as a first responder training facility would be welcomed by the industry. As a result, FRA funded an effort to design a training facility focused on the unique nature of bi-level equipment

while project stakeholders explored funding options that can be used for the construction of the facility.

During the construction of the first rollover rig, ENSCO worked with FRA and WMATA to develop the requirements for the design, location, and construction of the facility. This effort involved:

- Consulting with international parties to identify candidate facility designs
- Working with New Jersey Transit to secure and move a donated single level passenger rail coach car for use in the facility
- Conducting all required engineering analyses and developing all aspects of the rig's design based on the vehicle provided by New Jersey Transit
- Coordinating all site preparation and installation activities in Landover, MD, with WMATA personnel

## **1.2 Overall Approach**

The research was undertaken as a collaborated effort between FRA and its contractor, ENSCO, and Amtrak. Several meetings between FRA staff and Amtrak representatives from Northeast Corridor Operations, Emergency Management and Engineering were held to discuss critical issues such as Amtrak objectives, potential facility locations as well as aspects of ongoing operations and maintenance. Site visits were made by FRA to the site selected by Amtrak.

## **1.3 Organization of the Report**

This report is organized as follows:

- [Section 2](#) describes the vehicle and site specified by Amtrak.
- [Section 3](#) presents the various design concepts developed during this effort along with the evaluation criteria used to select the final design of the facility described in [Section 4](#).
- [Section 5](#) details the engineering analysis conducted on the critical components of the facility.
- [Sections 6](#) and [7](#) present estimates for the construction costs and schedule, respectively.
- [Section 8](#) provides a guide for all fabrication and assembly drawings produced for the facility.
- [Section 9](#) offers a summary of the analysis as well as future benefits and work.

## 2. Vehicle and Site Selection

---

### 2.1 Vehicle Selection

Since the purpose of the bi-level rollover rig is to train first responders on how to rescue passengers from a typical bi-level passenger car, the vehicle selection had to be made by using a vehicle with a typical layout and configuration. The vehicle also needed to be obtained in relatively good condition for little to no cost to the facility build project. ENSCO worked with Amtrak to identify the best vehicle for this purpose. Some bi-level coach cars in service in the U.S. are:

- California Surfliner—Alstom
- Seattle Sounder—Bombardier
- Metrolink—Hyundai Rotem
- New Jersey Transit—Bombardier
- Chicago Metra—Nippon Sharyo
- Amtrak Superliner—Pullman and Bombardier



**Figure 2. Amtrak Superliner Coach**

Figure 2 shows the Pullman and Bombardier Superliner Coaches that are fairly typical in design to many U.S. bi-level coach designs listed above. The Pullman cars are now over 40 years old and have been in continuous Amtrak service during that time. Amtrak has at least six of these cars in usable condition and other superliners are available from sources such as Gateway Rail Services in Madison, IL. Due to its availability and conformance to standard design practice, Amtrak selected this vehicle for the rollover rig.

### 2.2 Site Selection

Amtrak selected its Los Angeles, CA, maintenance facility as the designated site for the bi-level rollover rig. The Los Angeles location was selected for the following reasons:



- The West Coast has several rail lines using bi-level coaches including the California Surfliner, the Seattle Sounder, and Southern California Metrolink.
- The Los Angeles location offers an alternative to the east coast rollover rig for training convenience.
- Southern California allows training year-round.
- Amtrak has offered the land, the security of being within their facility, and the ability to operate the facility.
- The location offers convenient access to rail for bringing the coach car to the facility during construction.

Figure 3 shows the Los Angeles yard and the positions that the rollover rig may occupy. The area enclosed by the green box was Amtrak’s original selection, but may not be reasonable due to overhead power lines. The area enclosed in red is the alternative site.



**Figure 3. Amtrak’s Los Angeles Vehicle Maintenance Facility**

### 3. Concept and Selection Process

---

#### 3.1 Concept Development

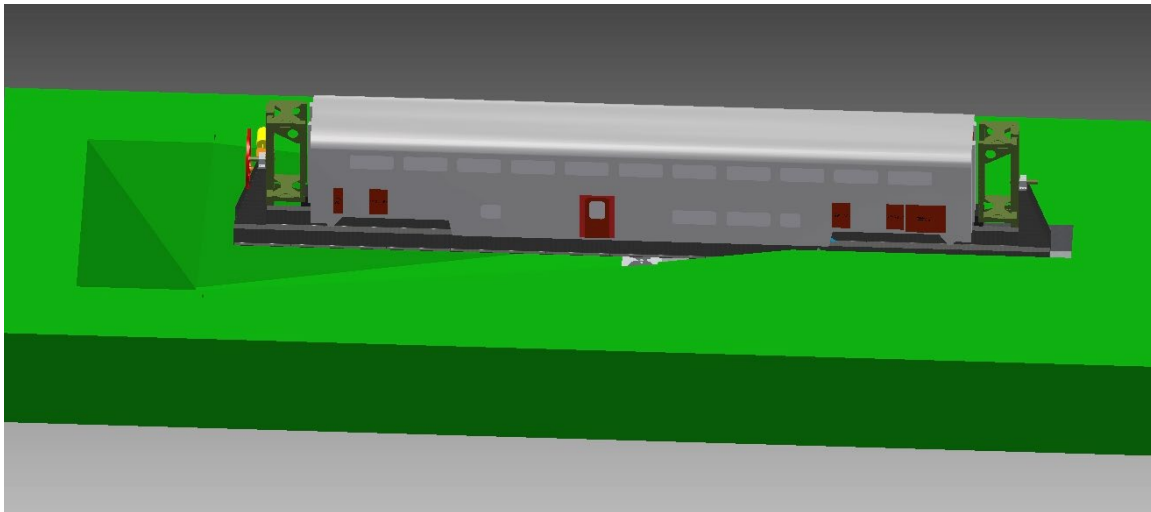
Four basic concepts for the rollover rig were developed based on the concept that there were two methods to roll the vehicle and two methods to raise one end of the vehicle. The two methods for rolling the vehicle were by the use of hoops that encircle the vehicle or rotation points on each end of the car in a rotisserie fashion. The two methods to lift one end of the vehicle were to place the vehicle on a bridge like structure, or by use of jacks that lift one end from the earthworks. These concepts for basic designs were developed and labeled as:

1. Rotisserie on Bridge
2. Rotisserie on Earthworks
3. Hoops on Bridge
4. Hoops on Earthworks

Each of these design concepts are discussed below.

#### 3.2 Rotisserie on Bridge

The basic design concept for the Rotisserie on Bridge design is shown in [Figure 4](#).

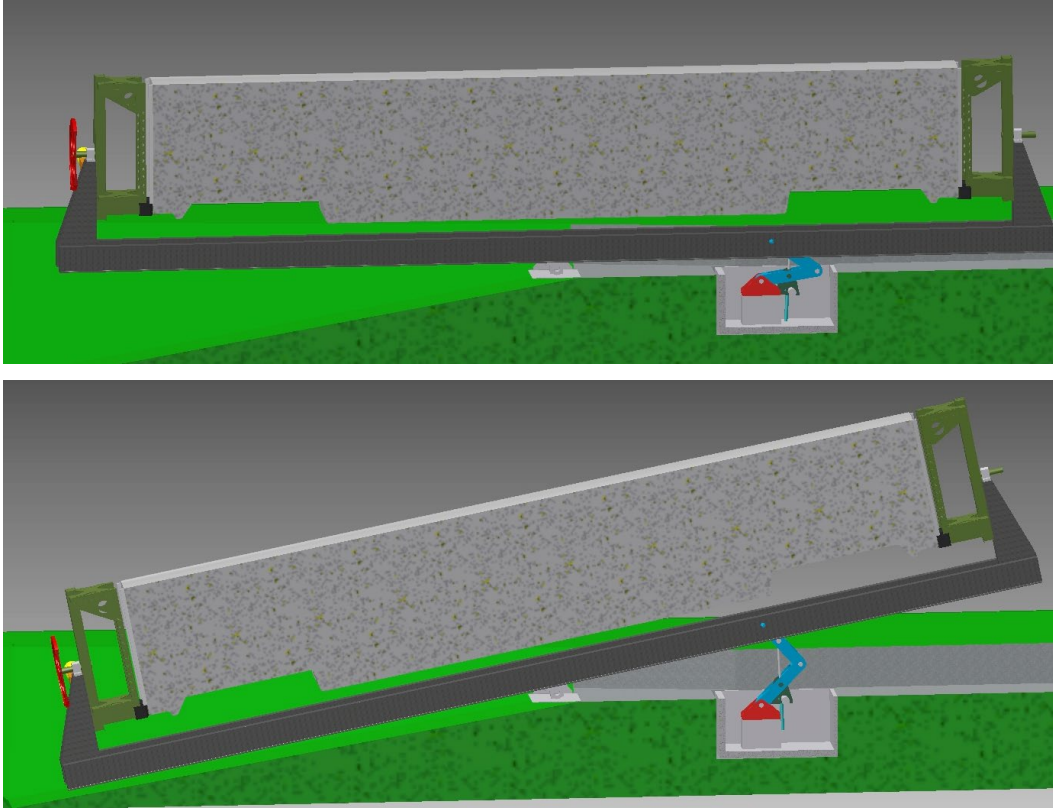


**Figure 4. Rotisserie on Bridge Design**

The vehicle is placed on a 90-foot double I-beam bridge structure containing stanchions for rotation bearing points used to rotate the vehicle. An extension frame on each end of the vehicle is used to connect to the rotation bearings and allow access to the end door. The bridge has a center pivot point to minimize the effort required to lift the vehicle. One end of the facility has a swale for the vehicle to drop into. Lifting is controlled by a loader style lift arm using a screw jack. Rotation of the vehicle at the rotisserie point uses an electric motor driving through a gear box and a spur gear drive.

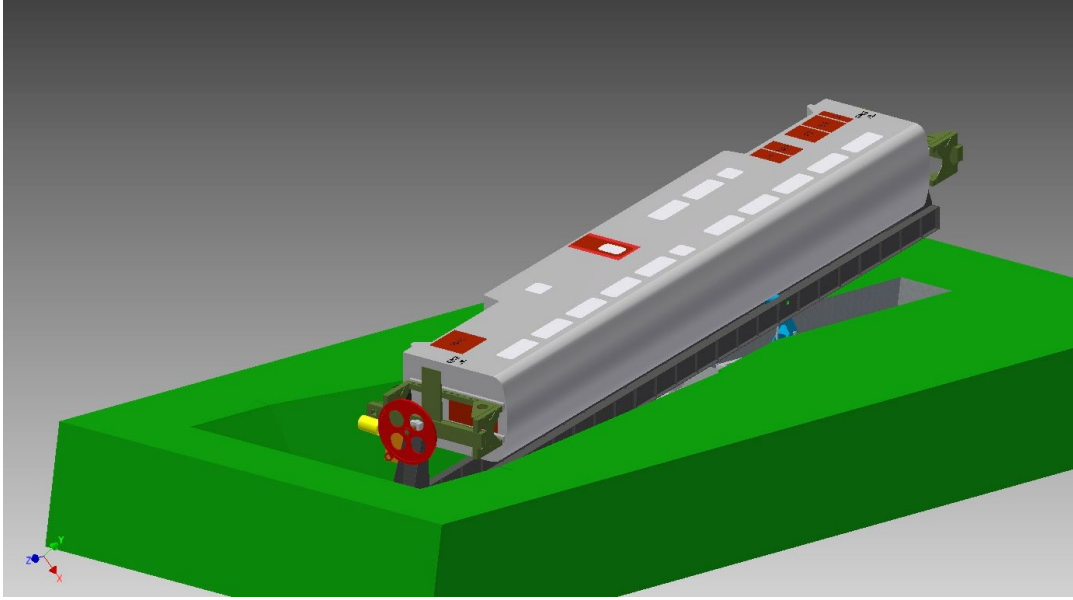
[Figure 5](#) illustrates the vehicle lift process.



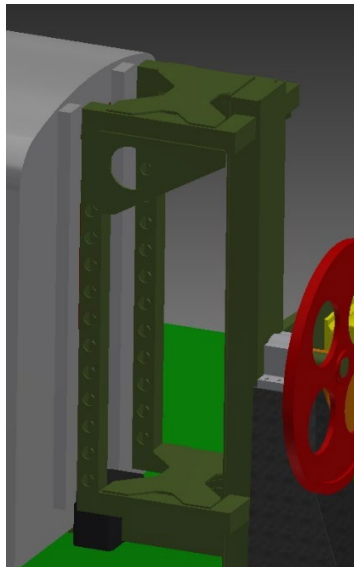


**Figure 5. Vehicle Lift Process for Rotisserie on Bridge Design**

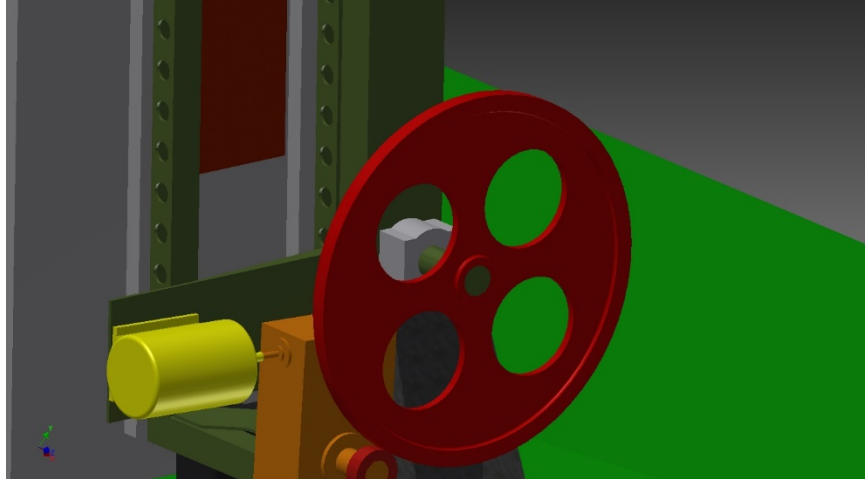
Figure 6 shows the concept with the vehicle rotated 90 degrees and the bridge tilted. Figure 7 shows the end-of-car extension used to pivot the vehicle while still allowing access to the end doors. Figure 8 shows the motor (yellow), the gear box (orange) and the spur gear (red) used to rotate the vehicle at a slow speed. Figure 9 shows the lift arm used to tilt the bridge located under the bridge.



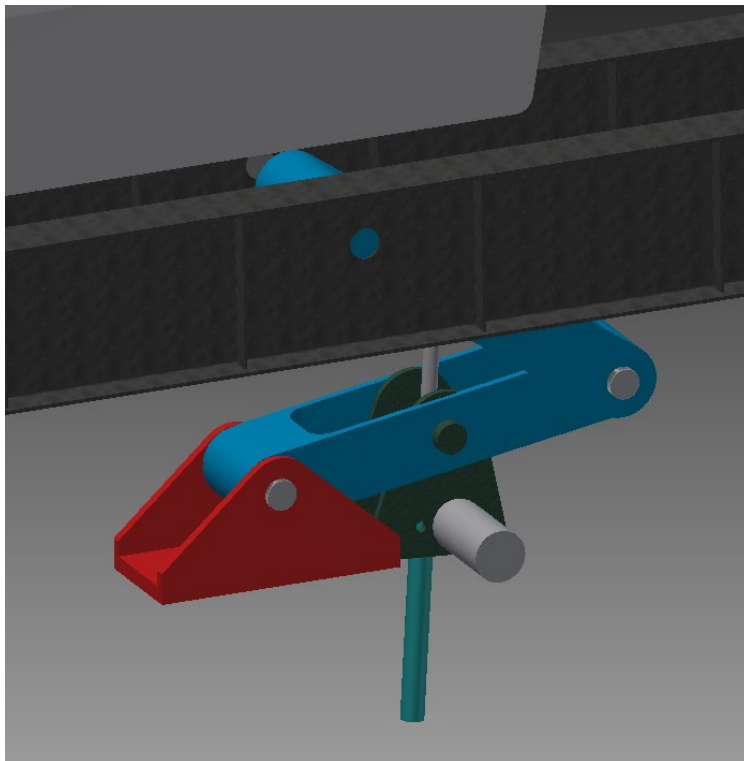
**Figure 6. Rotisserie on Bridge Design Rolled and Tilted**



**Figure 7. End of Car Extension in Rotisserie on Bridge Design**



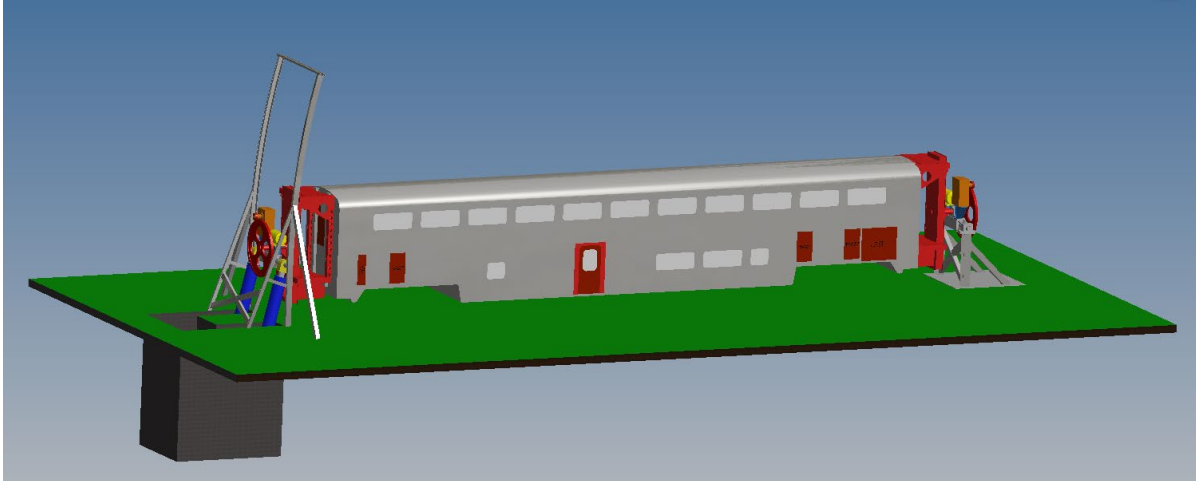
**Figure 8. Motor Drive for Rotation in Rotisserie on Bridge Design**



**Figure 9. Lift Arm Located Near Center Pivot Under Bridge in Rotisserie on Bridge Design**

### **3.3 Rotisserie on Earthworks**

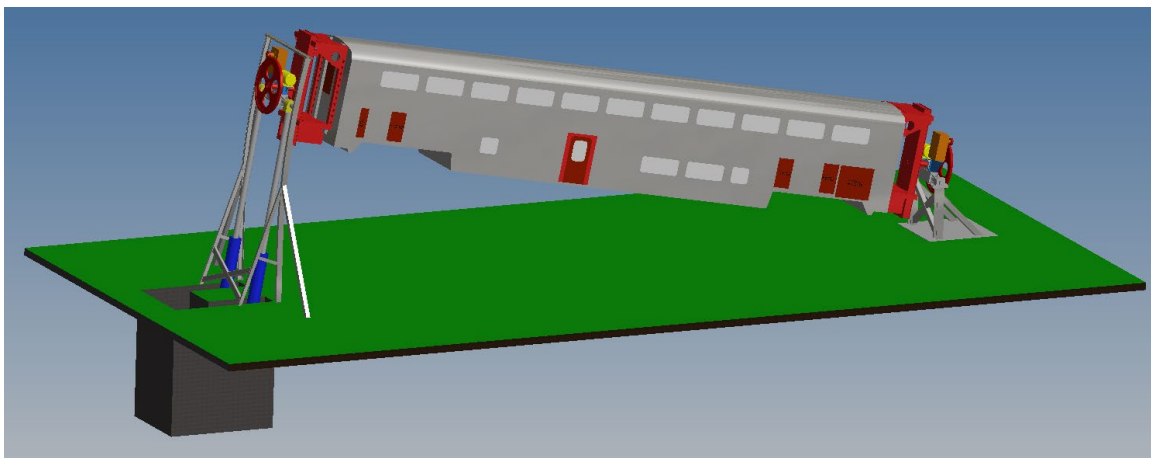
The basic concept for the Rotisserie on Earthworks design is shown in [Figure 10](#).



**Figure 10. Rotisserie on Earthworks Design**

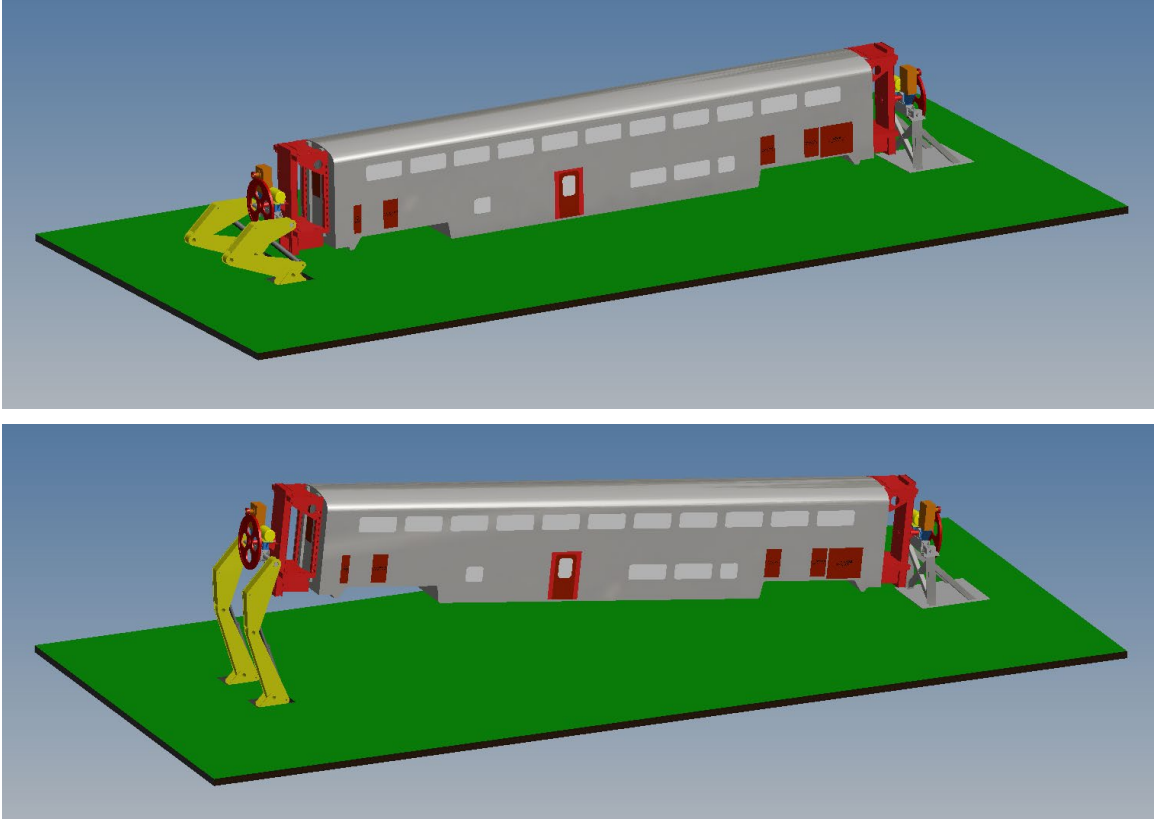
The Rotisserie on Earthworks design incorporates the same end frame extension used for the Rotisserie on Bridge design. These end frames employ a rotation axle which mates with a bearing affixed to a vertically movable frame. This bearing frame rides on a linear bearing on a vertical guide. Lifting is accomplished by use of large hydraulic cylinders or screw jacks. This arrangement allows full movement above the ground for full access to the vehicle sides. The rotation is accomplished using an electric motor driving a gear box and spur gear drive similar to that described in the previous concept. Because the car is lifted from the end using hydraulic cylinders or jacks, this concept requires minimal site preparation.

[Figure 11](#) shows the vehicle in the raised position for this design. In this version, the lift is accomplished using very long hydraulic cylinders. Screw jacks could also be used to perform a similar function.



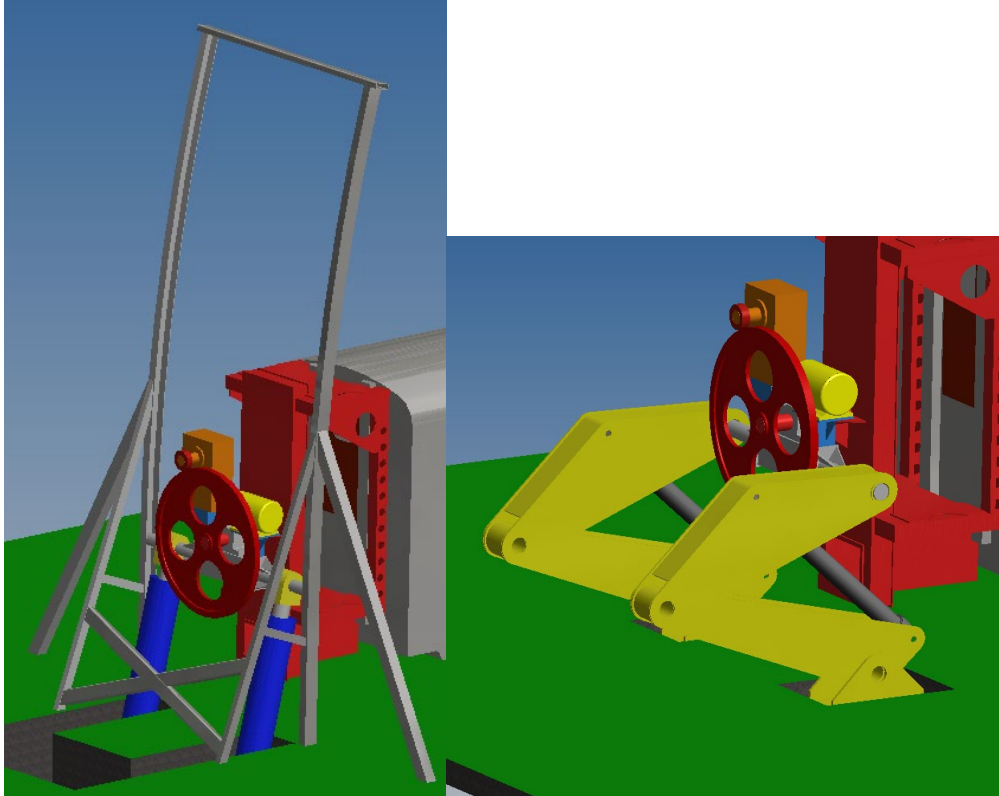
**Figure 11. Rotisserie on Earthworks Design in Fully Raised Position**

In [Figure 12](#), the long cylinders and guide track are replaced by loader arms which allow for shorter screw jacks to be used in what appears to be a more practical solution to raising the end of the vehicle.

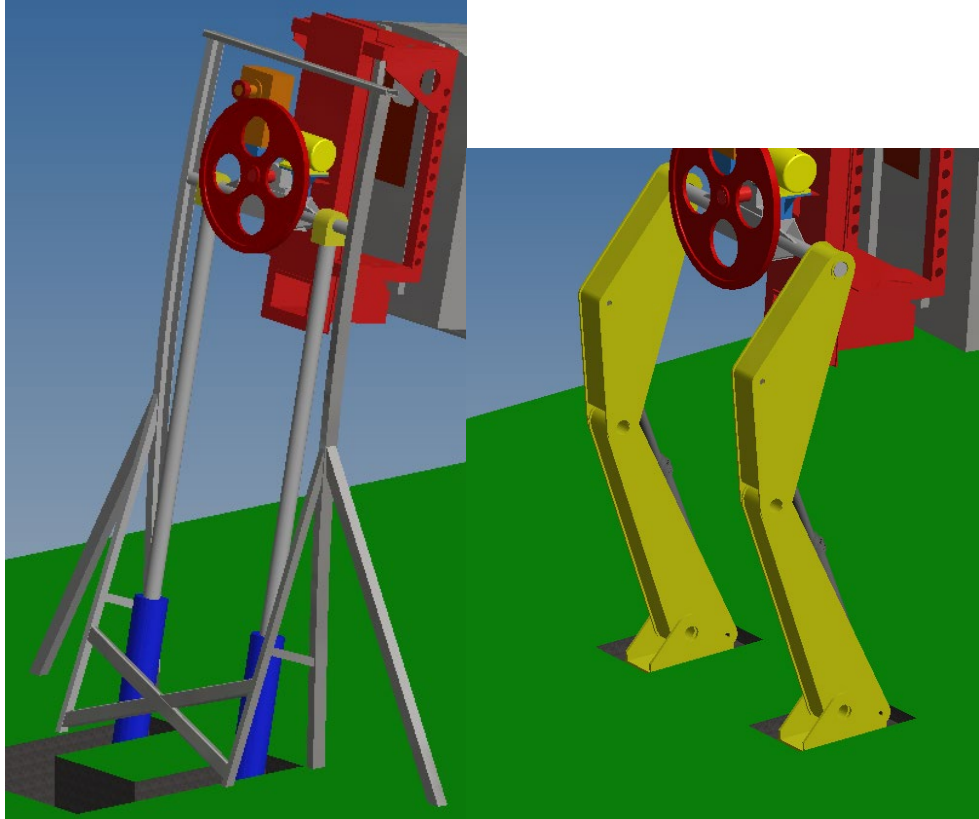


**Figure 12. Rotisserie on Earthworks Design Using Loader Arms**

Figure 13 shows a close-up of the lifting and rotating mechanisms in both configurations with the vertical guide and the loader arms in the lowered position. Figure 14 shows the same mechanisms in the raised position.



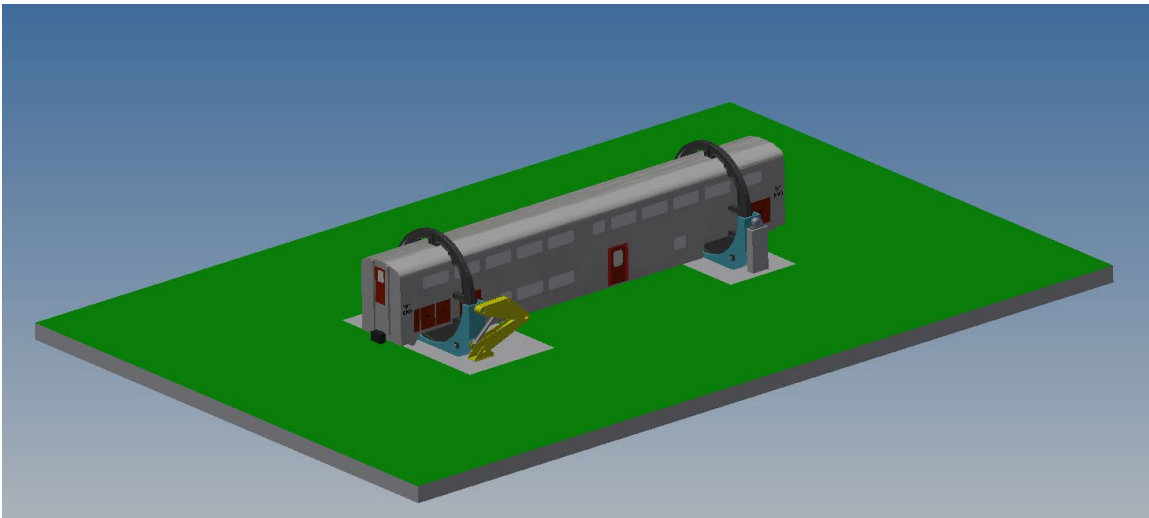
**Figure 13. Lifting and Rotating Systems in Lowered Position Showing Both Lift Devices, Rotisserie on Earthworks Design**



**Figure 14. Lifting and Rotating Systems in Raised Position Showing Both Lift Devices, Rotisserie on Earthworks Design**

### **3.4 Hoops on Bridge**

The Hoops on Bridge design is depicted in [Figure 15](#).



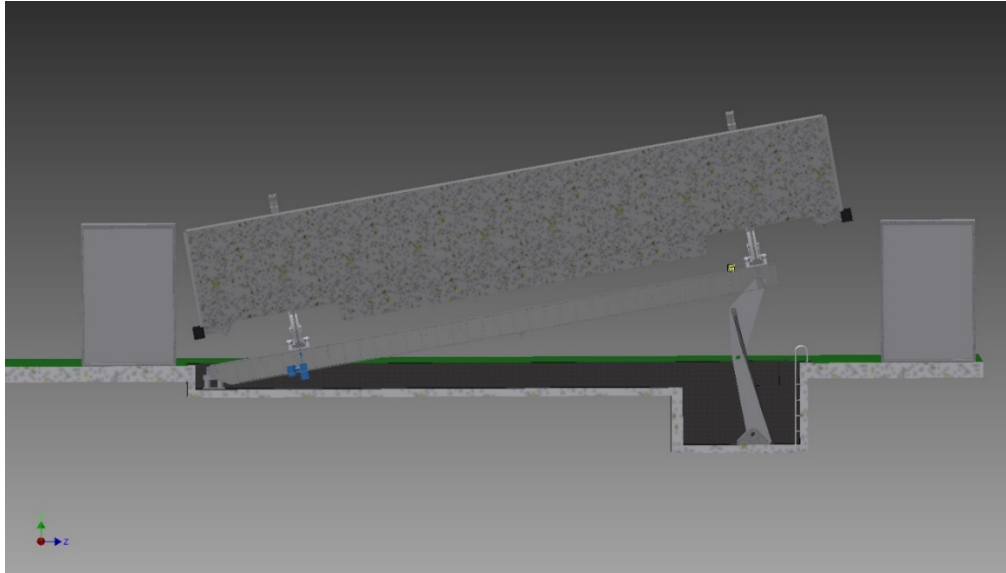
**Figure 15. Hoops on Bridge Design**



In this concept, a 70-foot bridge structure is used, which is shorter than that used in the Rotisserie on Bridge design. The shorter bridge structure is possible because it spans between two hoops that are located at the car bolster points and does not need to extend beyond the car length. Two 20-foot diameter hoops surround the vehicle and ride on cradles that are affixed to the bridge. Each hoop rolls on four pairs of rollers that are part of walking beam suspensions in the cradles. The bridge pivots at one end of car and is lifted by loader arm style linkages. Because the bridge in this design pivots on one end, the loader arms need to be much larger than found in the Rotisserie on Bridge concept. This concept could be adapted to the center rotation as well, so this design presents a variation in how a bridge can be rotated. The rotation of the vehicle on its two hoops is controlled by a traction winch.

On each end of the vehicle, a shed is used to store related equipment for training and serves as a simulated adjacent vehicle. The use of storage sheds to simulate adjacent cars can be adapted to other designs as well.

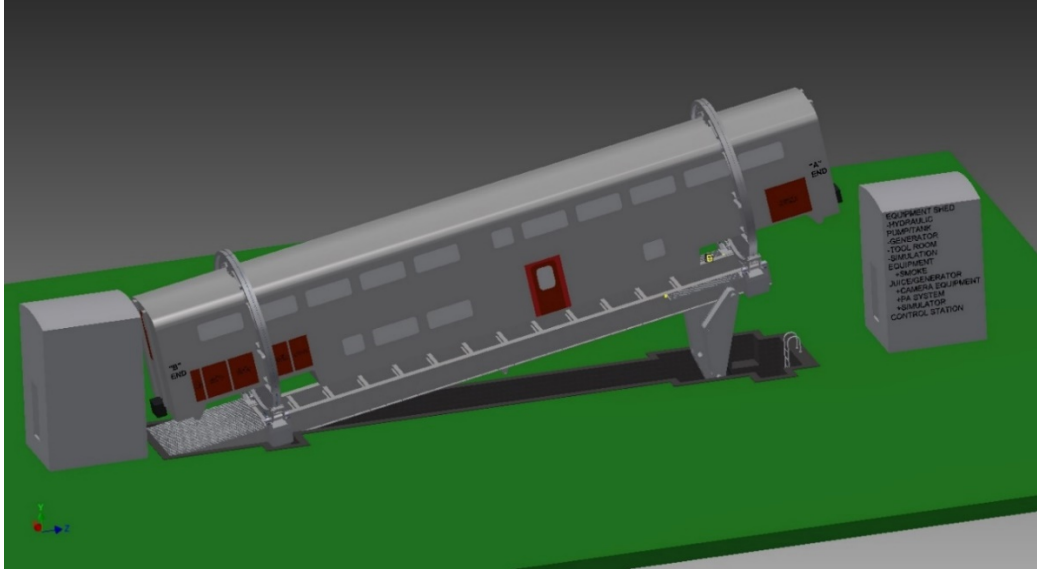
Figure 16 depicts the systems in a cutaway fashion to show the undercar lift system that resides in a pit. The drawings show the car in the lowered and fully raised orientations.



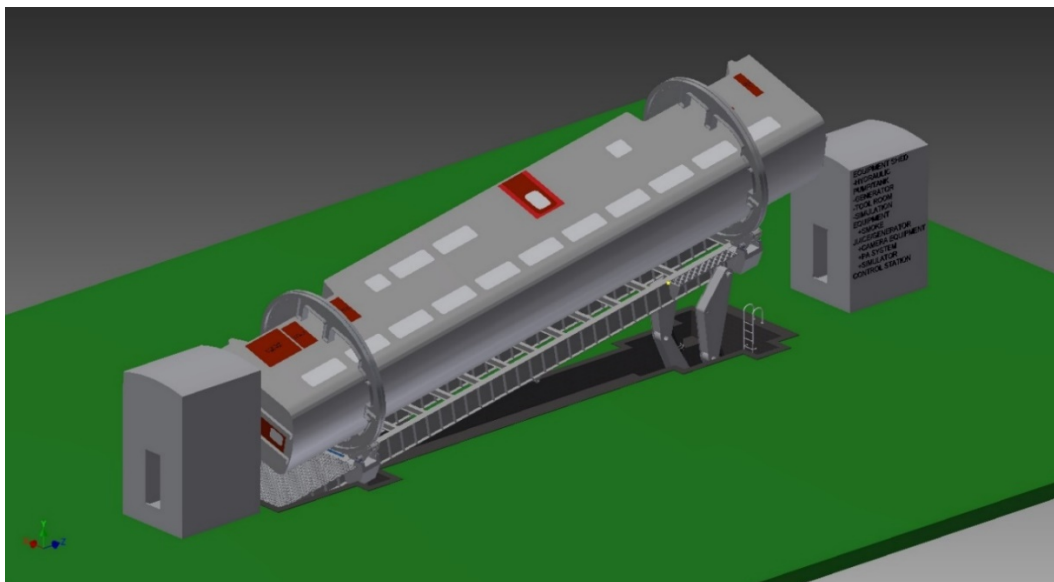
**Figure 16. Lowered and Raised Vehicle in Hoops on Bridge Design**

Figure 17 shows the vehicle in a raised position to the height of the adjacent vehicle as would be the case in an override accorded wreck situation. Figure 18 shows the vehicle in a rolled and lifted position as would be the case if the vehicle overrode the adjacent vehicle.



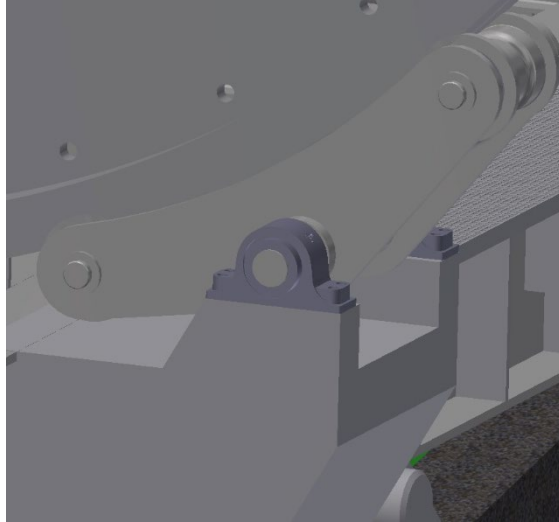


**Figure 17. Lifted Vehicle in Hoops on Bridge Design**

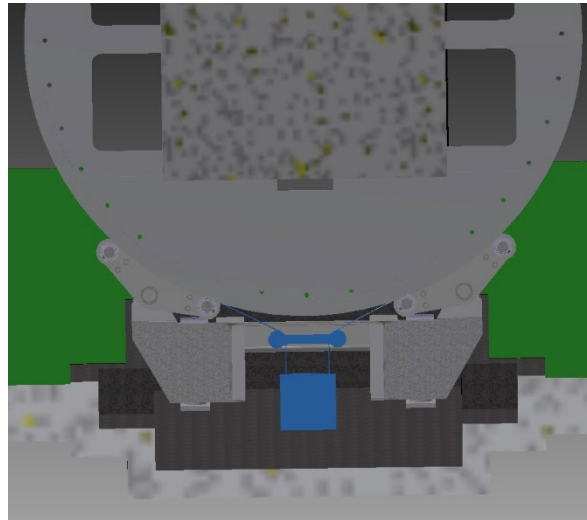


**Figure 18. Lifted and Rolled Vehicle in Hoops on Bridge Design**

Figure 19 depicts one of the two walking beams used when the vehicle rotates. Figure 20 shows the rotational drive which works through a bridge mounted bi-directional push-pull winch. This winch drive provides rotational control in both directions to prevent the vehicle from inadvertently rolling.



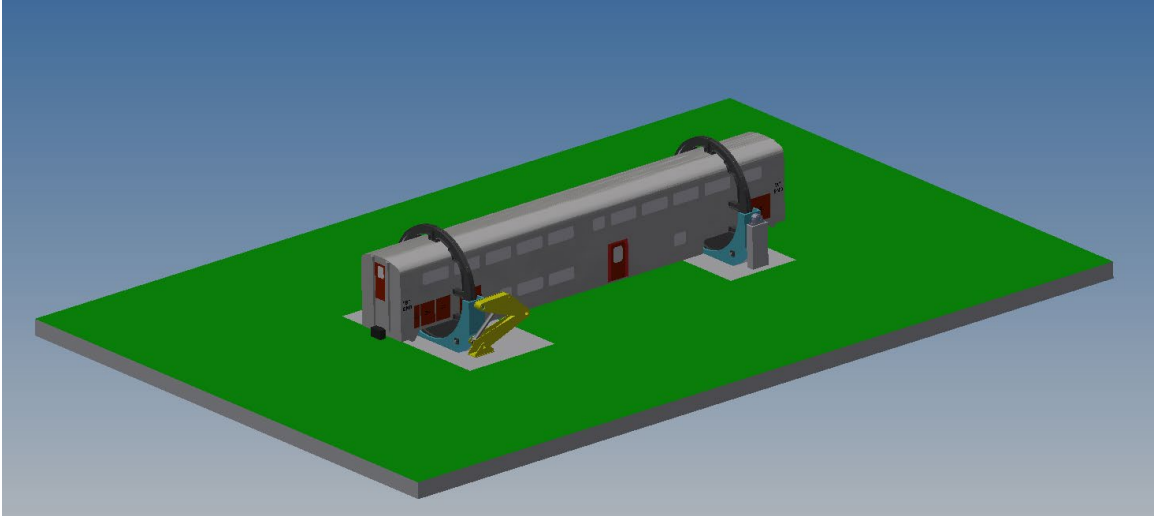
**Figure 19. Walking Beam**



**Figure 20. Push-Pull Winch**

### **3.5 Hoops on Earthworks**

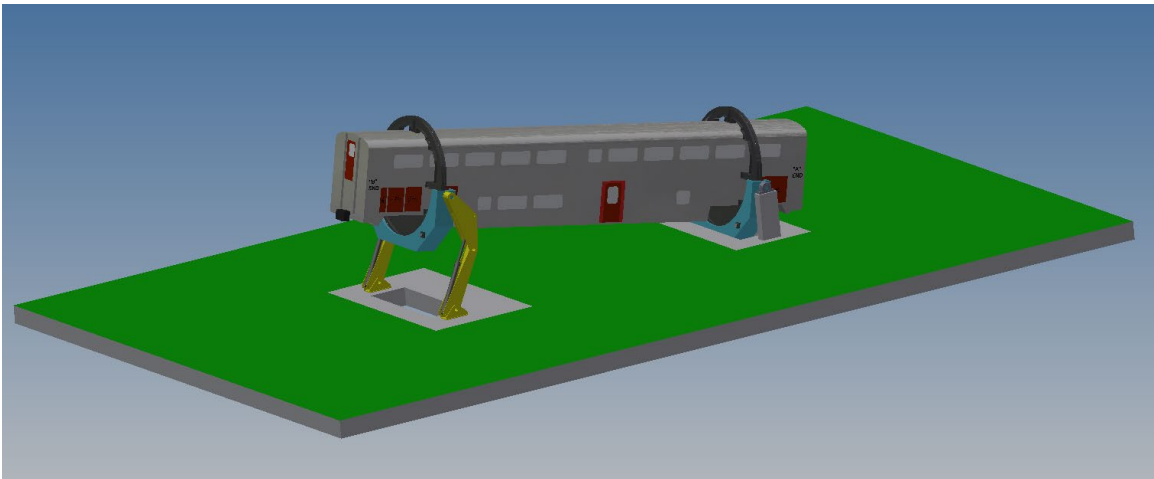
The Hoops on Earthworks concept is illustrated in [Figure 21](#).



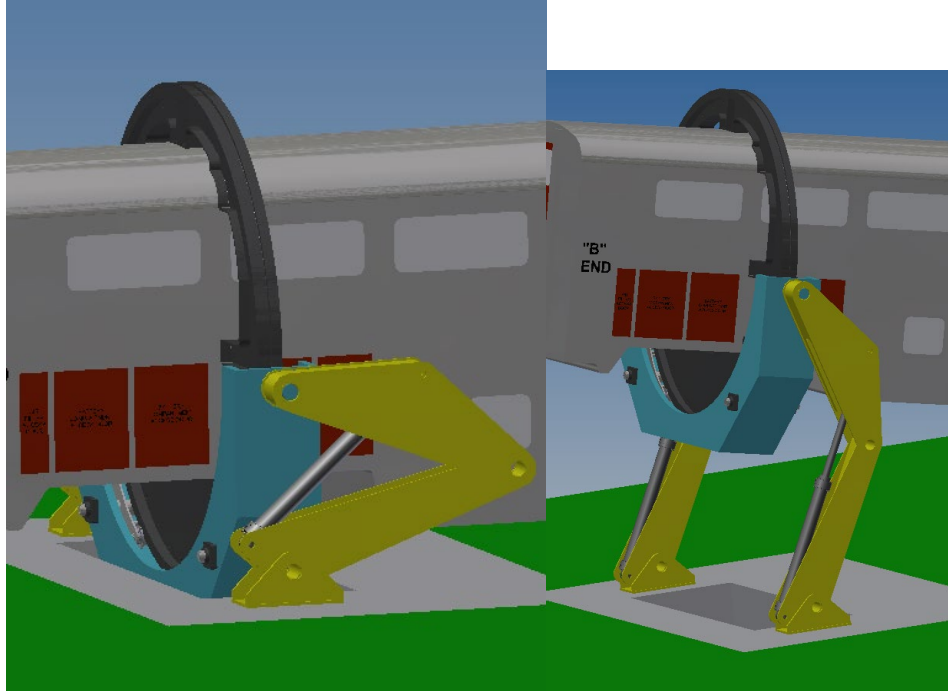
**Figure 21. Hoops on Earthworks Design**

In the Hoops on Earthworks design, the vehicle is mounted within two large 20-foot diameter hoops which are rotated in cradles. This portion of the design is very similar to that found in the Hoops on Bridge design. However, in this concept one cradle is lifted by large loader arms that rest directly on a foundation. The opposite end cradle is fixed to concrete piers and can only rotate to allow the other end of the vehicle to be lifted. The loader arms are powered by large screw jacks. Rotation of the vehicle is controlled using a push-pull winch. This concept requires a minimal amount of site excavation and frees up all doors on the car.

Figure 22 shows the vehicle in the lifted position which is approximately one car height above the ground. Figure 23 illustrates the loader arms used to lift and lower the vehicle.

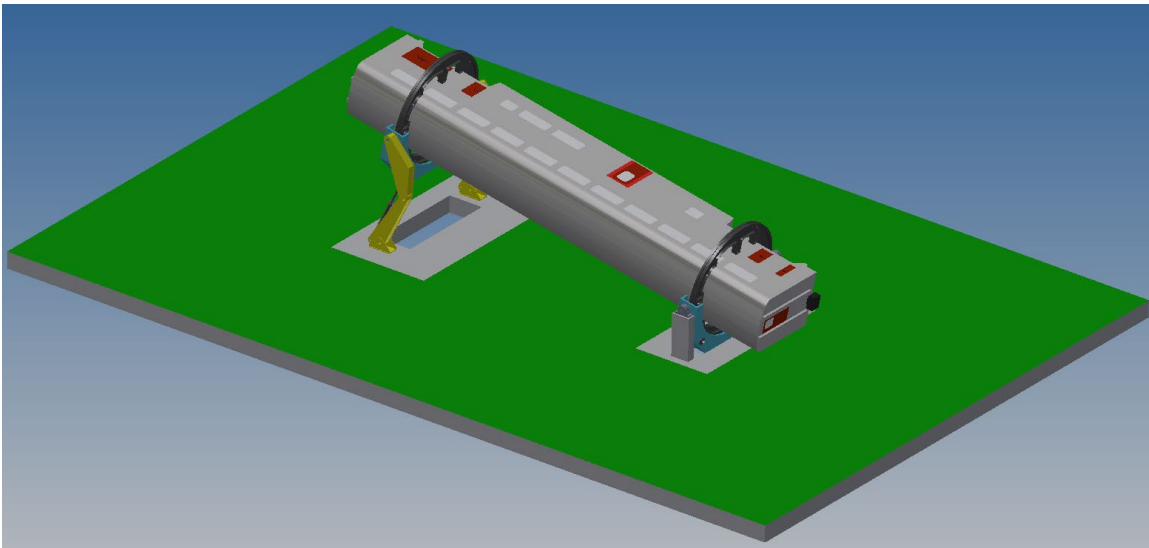


**Figure 22. Hoops on Earthworks Design in Lifted Position**



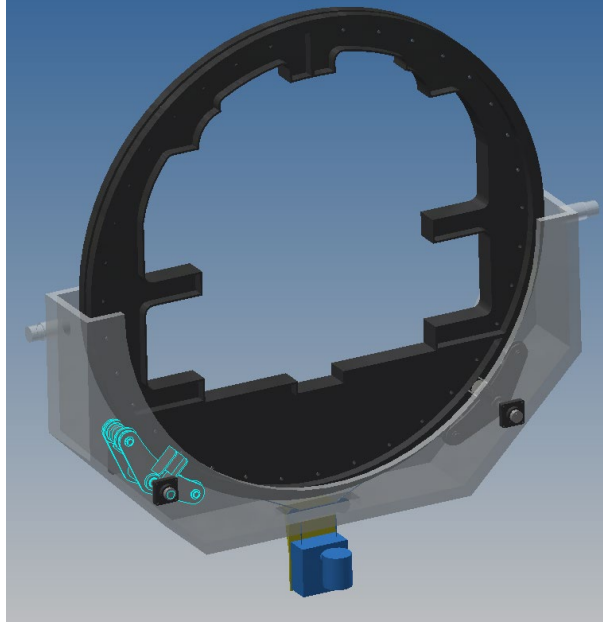
**Figure 23. Loader Arms Depicted in Lowered and Raised Positions for Hoops on Earthworks Design**

Figure 24 shows the car rolled and lifted clearly showing the hoops that surround the vehicle at the bolster locations.

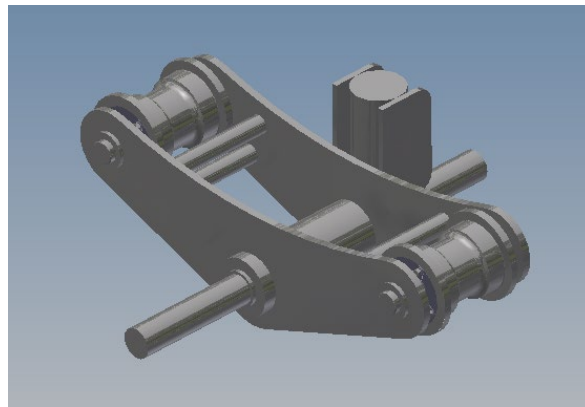


**Figure 24. Vehicle Lifted and Rolled to 90 Degrees in Hoops on Earthworks Design**

Figure 25 shows the cradles with the hoop placed with in it. The walking beams can be seen inside the cradle. Figure 26 shows the walking beam with two rollers and a center pivot axle.



**Figure 25. Cradle and Hoop Assembly for Hoops on Earthworks Design**



**Figure 26. Walking Beam Assembly Used in Hoops on Earthworks Design**

### **3.6 Evaluation Criteria and Relative Weightings**

A comparative evaluation of the four concepts was conducted utilizing the evaluation criteria shown in [Table 1](#). These evaluation criteria were selected to align with the training requirements, cost limitations, and safety considerations of the facility. Each evaluation criteria was given a weighting based on its overall assessed importance.

**Table 1. Comparative Evaluation Criteria**

#	Evaluation Criteria	Relative Weighting Factor
1	End Lift Mechanism Design and Engineering Risk	2

#	Evaluation Criteria	Relative Weighting Factor
2	Realism of Vehicle Crash Setting	1.8
3	Roll Mechanism Design and Engineering Risk	1.5
4	Ability to Easily Access Side Door	1.2
5	Ability to Easily Access Windows	1.2
6	Ability to Easily Access End Doors	1
7	Relative Cost	1

Table 2 shows the results of the comparative assessment of the four concepts with a number from 1 to 3 assigned to each parameter for each concept and then multiplied by the weighting and totaled.

**Table 2. Comparative Evaluation of Four Concepts**

Evaluation Parameter	Weight Factor	Rotisserie on Bridge		Rotisserie on Earthworks		Hoop on Bridge		Hoop on Earthworks	
		Raw	Weighted	Raw	Weighted	Raw	Weighted	Raw	Weighted
End Lift Mechanism Design and Engineering Risk	2	3	6	1	2	3	6	2	4
Realism of Vehicle Crash Setting	1.8	3	5.4	2	3.6	3	5.4	3	5.4
Roll Mechanism Design and Engineering Risk	1.5	2	3	2	3	3	4.5	3	4.5
Ability to Access Side Door	1.2	2	2.4	2	2.4	3	3.6	3	3.6
Ability to Access Windows	1.2	3	3.6	3	3.6	2	2.4	2	2.4
Ability to Access End Doors	1	1	1	1	1	3	3	3	3
Relative Cost	1	2	2	1	1	2	2	3	3
<b>Total</b>		16	<b>23.4</b>	12	<b>16.6</b>	18	<b>26.9</b>	19	<b>25.9</b>

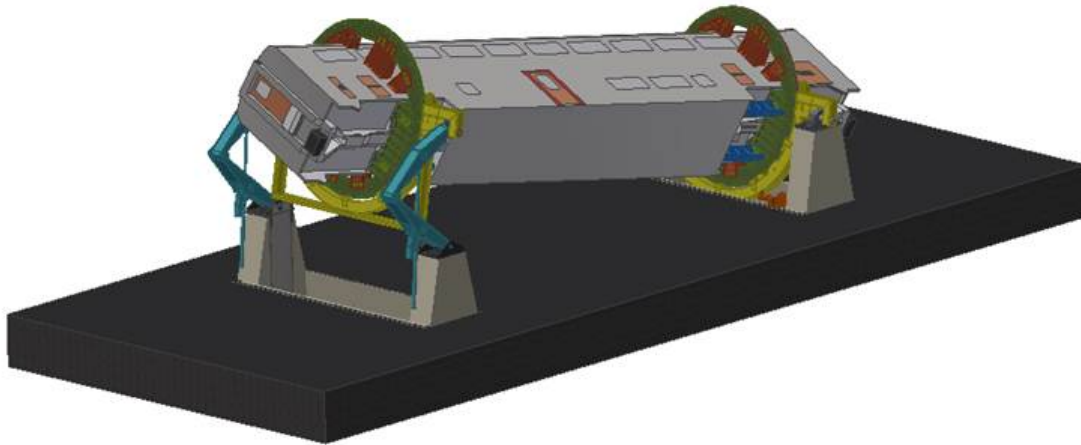
The results show that both hoop-based concepts score relatively close to each other. The Hoops on Earthwork design was selected as the final design because of its lower construction cost and superior access to the vehicle for training purposes.



## 4. Description of Rollover Rig Facility Design

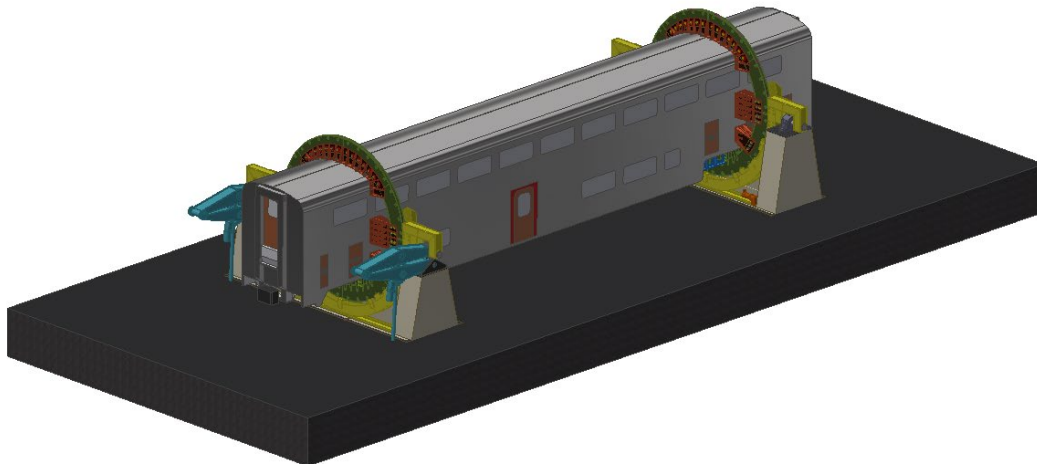
---

Figure 27 shows the final design of the bi-level rollover rig based on the Hoops on Earthworks concept. In this section, a description is provided of the various components of the design. The actual drawings of the components are contained in an accompanying portfolio that is listed in [Section 8](#).



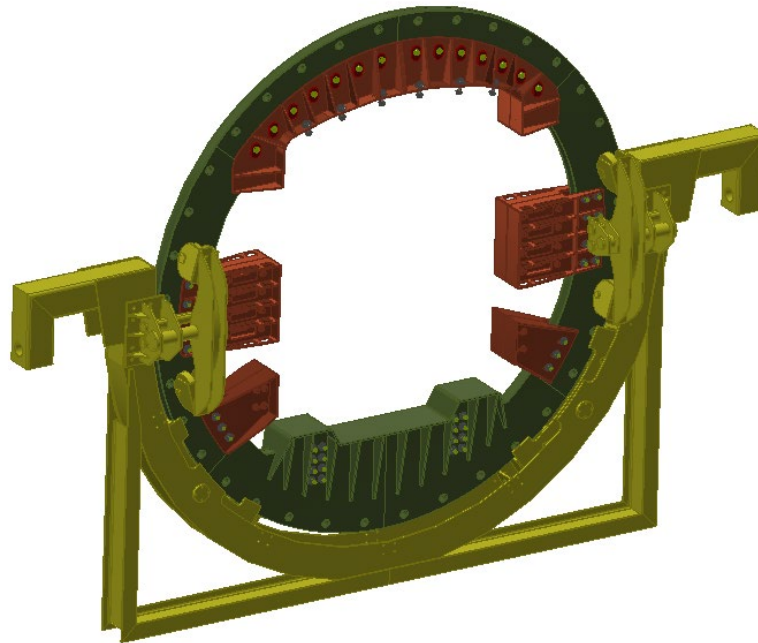
**Figure 27. Final Design of Bi-Level Rollover Rig**

The final design mounts the entire vehicle onto four concrete pillars. On the lift end, the pillar rises 7 feet-5 inches above the ground with the loader arms mounted on top. On the opposite end, the pillars are 9 feet high and have pillow block bearings mounted on top of the pillars. The heights are set such that when the vehicle is lowered it sits at a normal height above the top of the rail for that vehicle. [Figure 28](#) shows the vehicle in its lowered position and demonstrates that when the loader arms are collapsed they provide the height difference between the pillars.



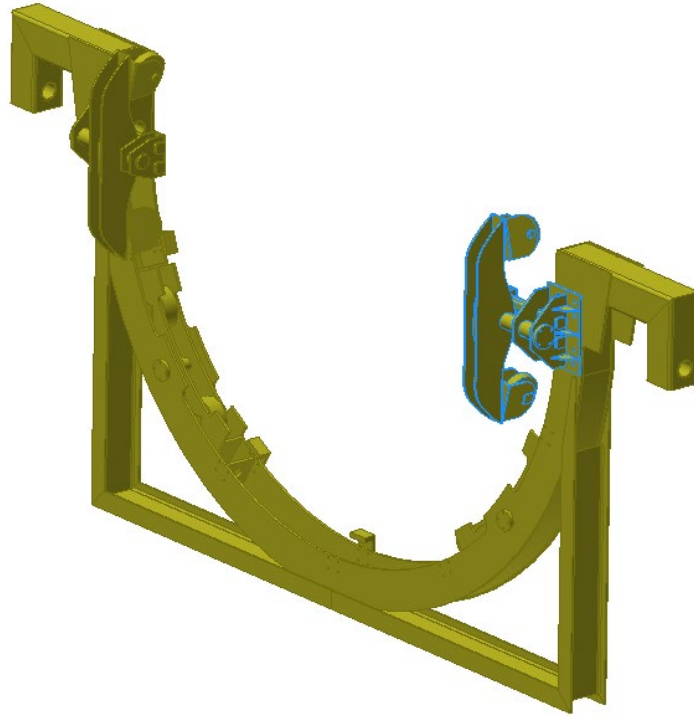
**Figure 28. Vehicle Shown in Normal Position**

Figure 29 shows the cradle with the hoops and walking beams in place. The cradle weldment is in the form of a crescent with an open channel cross-section. Two walking beams are used to evenly load four steel rollers during rotation. Two additional walking beams are used for side rollers on the down slope side of the cradle to retain hoops when tilted. A lower cross frame provides lateral stability when the rollover rig is raised by bearing against the pillar. The vehicle rotates on pins at the vehicle center of gravity (CG) height.



**Figure 29. Cradle, Hoop and Walking Beams**

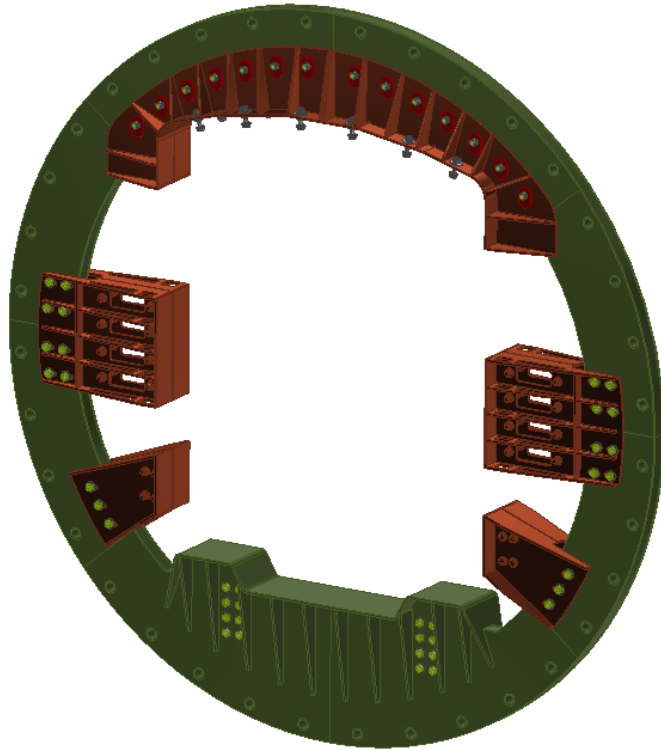
Figure 30 shows the cradle weldment. The longitudinally oriented walking beams allow the vehicle load component to be transferred to the cradle when the vehicle is lifted. Safety catches can be seen around the edge of the cradle. The cradle is connected to the lift arms at the clevis points shown at the top. The framework shown at the bottom is used to hold the winch for rotation and to act as lateral safety guides to absorb wind loads when the system is raised.



**Figure 30. Cradle Weldment**

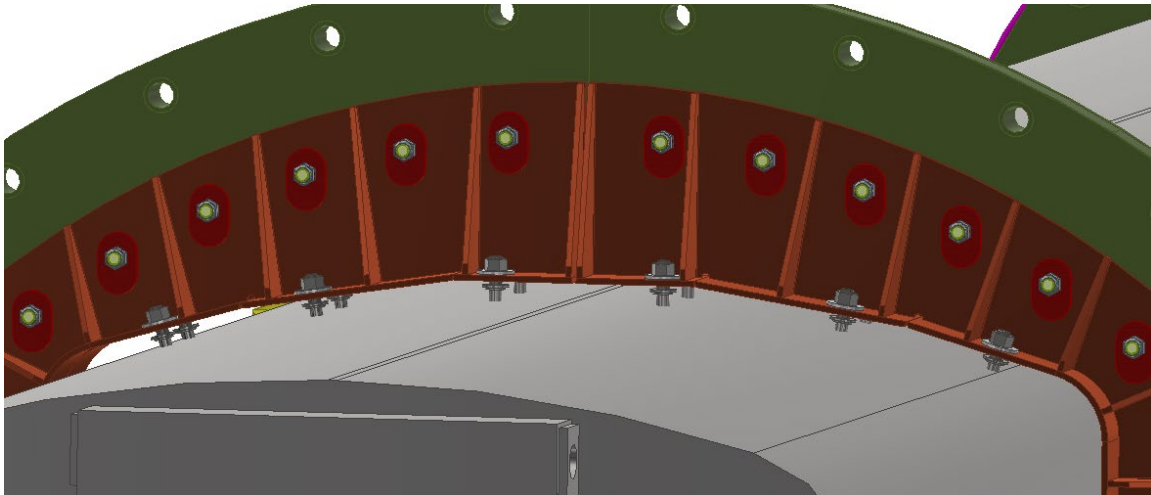
Figure 31 shows the hoop assembly. The hoop is a ring with a box section added for strength. A series of holes which contain tubes used as anchor points for safety pins are located every 10 degrees around the periphery of the hoop.

The hoops are made in two halves that join along the vertical center plane. This allows the vehicle to be placed into the hoops during installation. The lower half has a bench designed to fit the contours of the car undercarriage. Two lower adjustable brackets are used to connect to the lower portion of the car side walls. The adjustable center brackets connect to the center of the car and are also used to join the two halves of the hoop. The upper bracket adjusts to fit the contour of the car roof and connects to the upper half of the hoop. The brackets are bolted to the body around the periphery using welded sleeves that run through body wall.



**Figure 31. Hoop Assembly**

The body wall sleeves depicted in [Figure 32](#) anchor the hoops to the car. The bolts used in the body wall sleeves penetrate the vehicle outer and inner skins adjacent to the z cross members. The sleeves have flange plates that are welded to the outside skin of the vehicle.



**Figure 32. Body Wall Anchor Sleeves**

[Figure 33](#) depicts the loader arms. The arm assembly consists of an upper arm and a lower arm that are connected at a pinned joint. A 50 ton Joyce Dayton screw jack is used to connect the two arms from the center of each arm. At the lower arm, the jack is fitted with a trunnion adapter to allow it to swivel in the arm. At the top of the loader arm, the jack is fitted with a

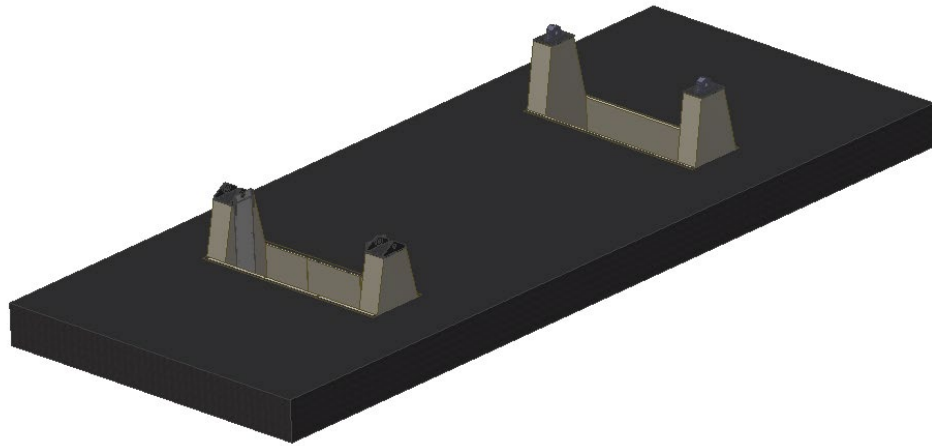
spherical rod end that is pinned into the upper arm. The lower arm is pinned to a base plate that bolts to the top of the pillar. The screw jacks cannot back drive, thus providing inherent safety not found in hydraulic cylinders. This is supplemented by lift locks that lock the cradle to the pillars at different height increments. The critical buckling load of screw jacks was analyzed and determined to be high enough to provide large safety factor under the vehicle load.



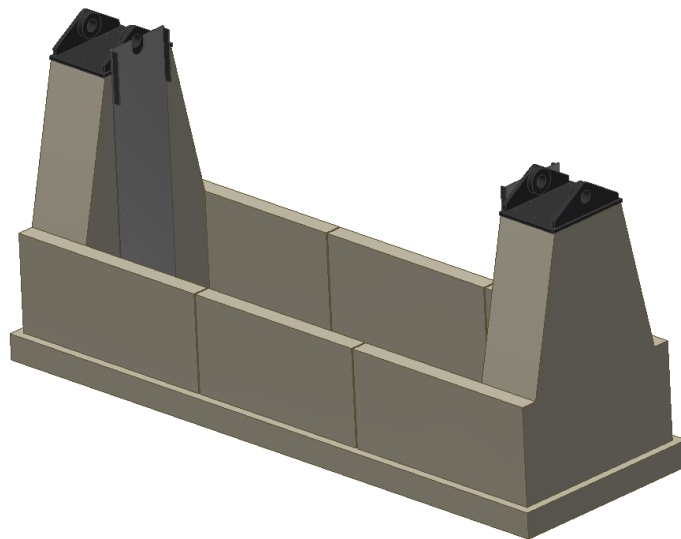
**Figure 33. Loader Arms Used to Raise Vehicle**

The entire system rests on concrete pillars that are sitting on top of a large concrete slab. The concrete slab connects the pillars and is reinforced with steel rebar to absorb the bending load in the pillars. The slab sits approximately 4 feet below grade providing a trench between the slabs that the cradles sit in. Concrete side walls complete the trench.

[Figure 34](#) shows the two sets of pillars that are 49.5 feet apart. [Figure 35](#) illustrates a pillar and slab assembly removed from the soil. The slab is 15 inches thick and contains 21 #7 rebars along the lateral axis, connected to 11 #5 vertical pillar rebars. There are also #5 rebars running perpendicular to the aforementioned rebars to create cages.

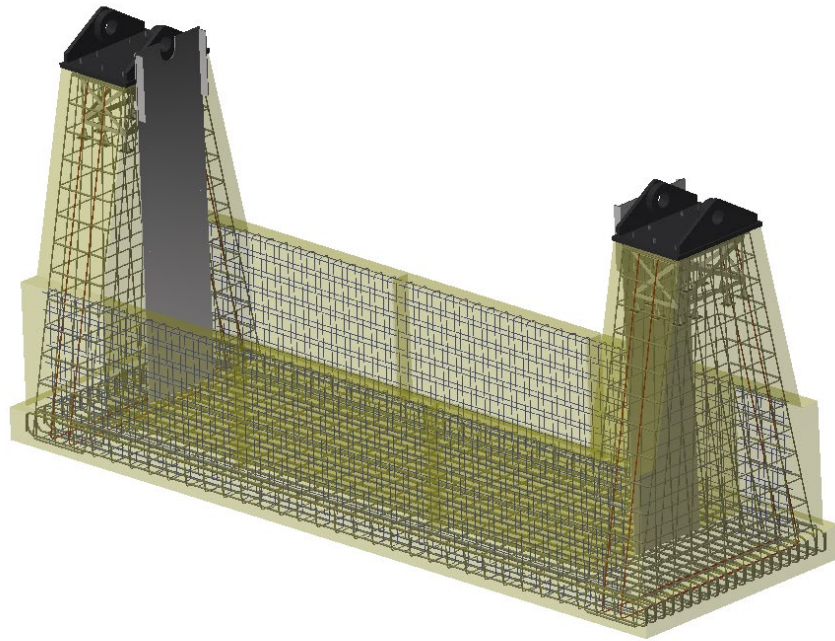


**Figure 34. Concrete Pillars**



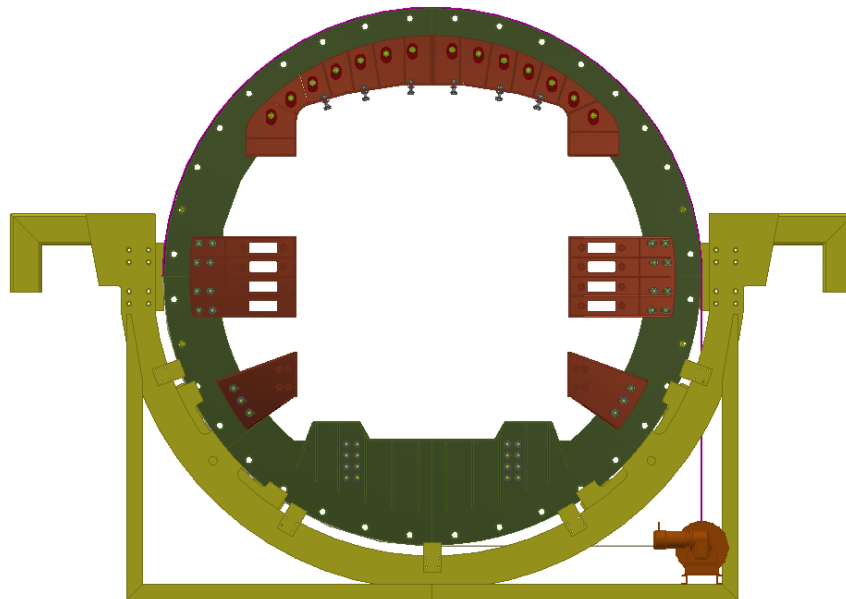
**Figure 35. Concrete Pillars, Slab and Side Walls**

Figure 36 shows a cutaway of the foundation slab and pillars with the internal rebar reinforcement.



**Figure 36. Reinforcement of Concrete Slab and Pillars**

The vehicle is rotated on each end by synchronized push pull winches. As shown in [Figure 37](#), the winches are attached to the lower frame of the cradles. The cable comes off the winch in both rotational directions and connects at a point on the opposite side of the hoop.



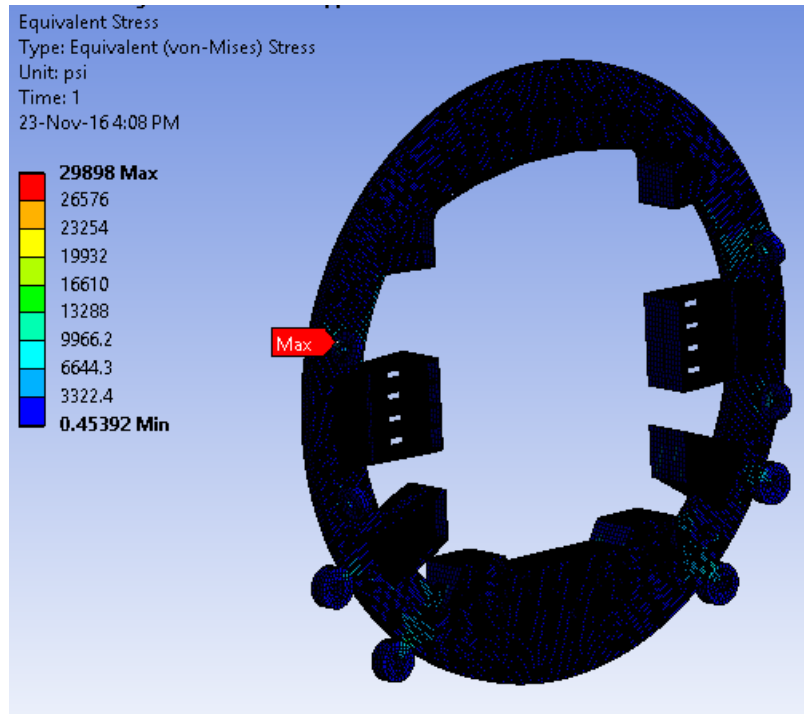
**Figure 37. Push-Pull Winch Arrangement**

## 5. Component Design Analysis

---

This section presents the results of the analyses of the hoops and cradles for the bi-level rollover rig using ANSYS Finite Element Software.

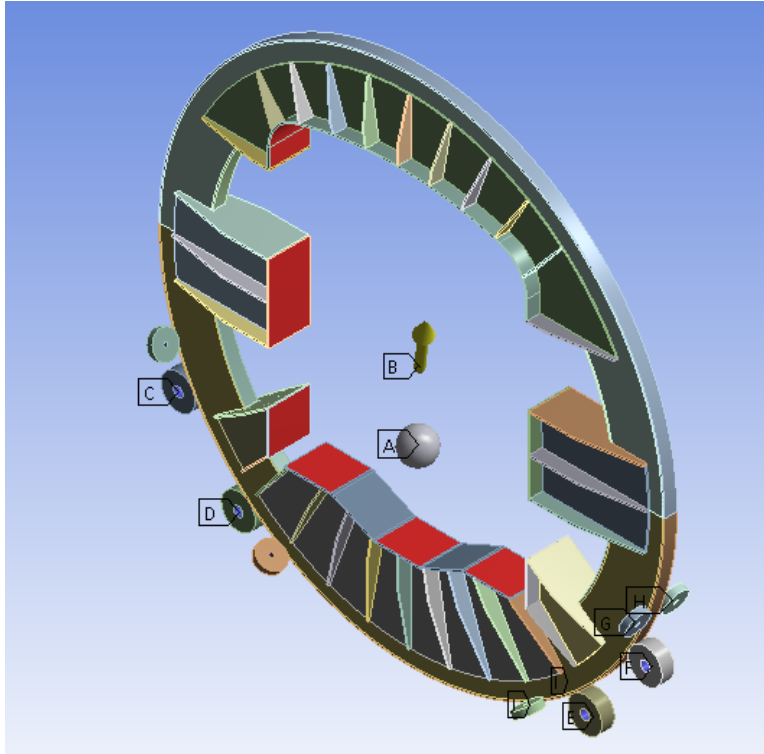
Figure 38 shows the Von Mises stress plot for the hoops under a loading condition with the vehicle raised to full height and under an 80-mph wind loading condition. The maximum stress of 29,900 psi occurs at the joint between the two halves of the hoop. This is an acceptable level of stress.



**Figure 38. Von Mises Stress Plot for Hoop**

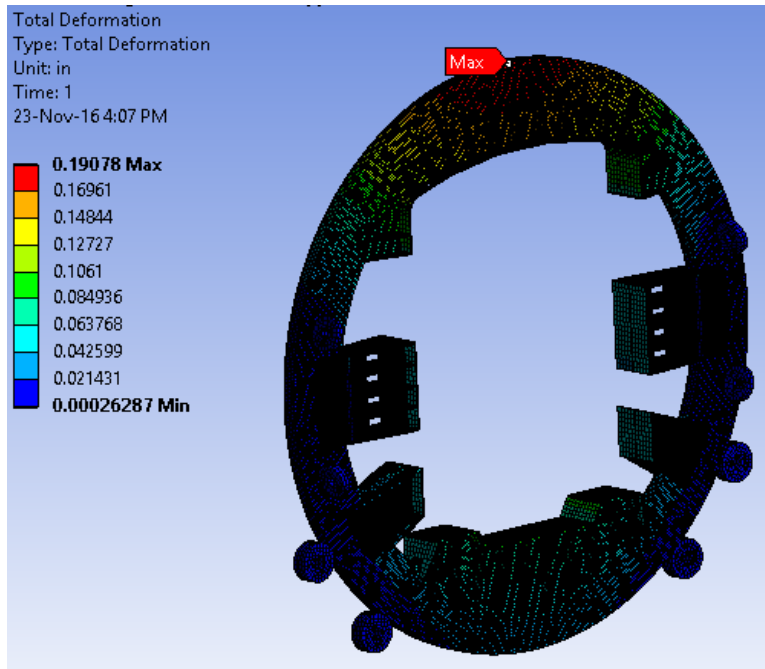
Figure 39 shows the constraints and loads associated with the stress plot in Figure 38. The letters indicate where constraints are placed in the model.





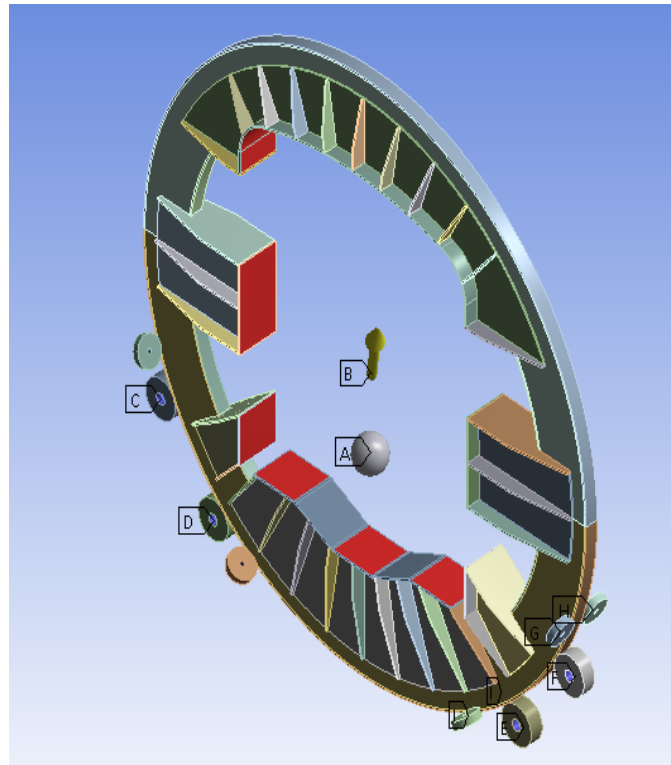
**Figure 39. Constraint and Loading Plot for Hoop**

Figure 40 shows the deformation plot for the hoops under a loading condition with the vehicle raised to full height and under an 80-mph wind loading condition. The maximum deformation of 0.19 inch occurs at the top of the upper hoop half. This deflection is within acceptable limits.



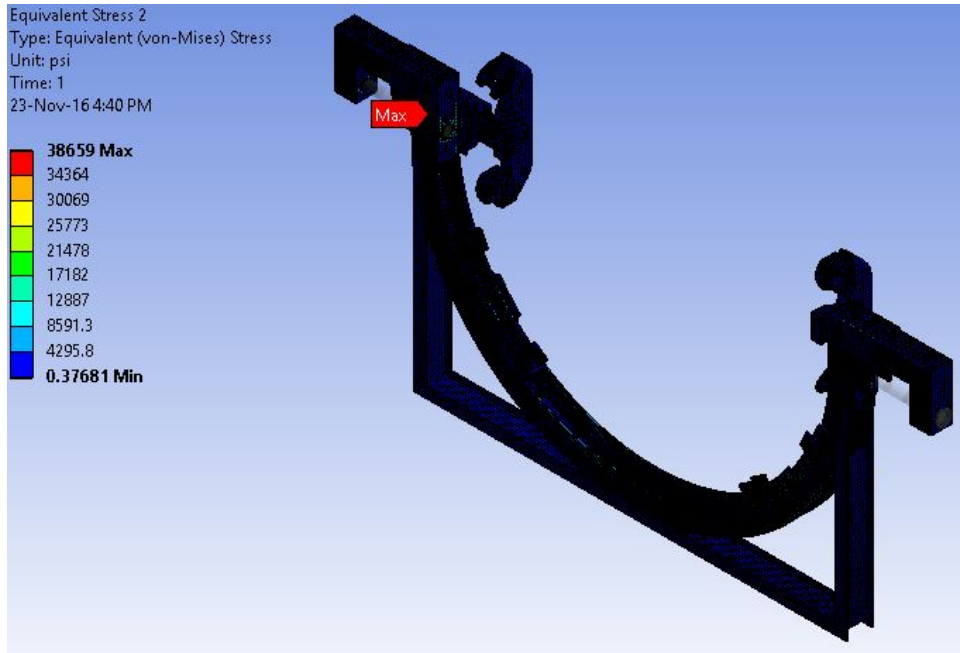
**Figure 40. Deformation Plot for Hoop**

Figure 41 shows the constraints and loads associated with the deformation plot in Figure 40.



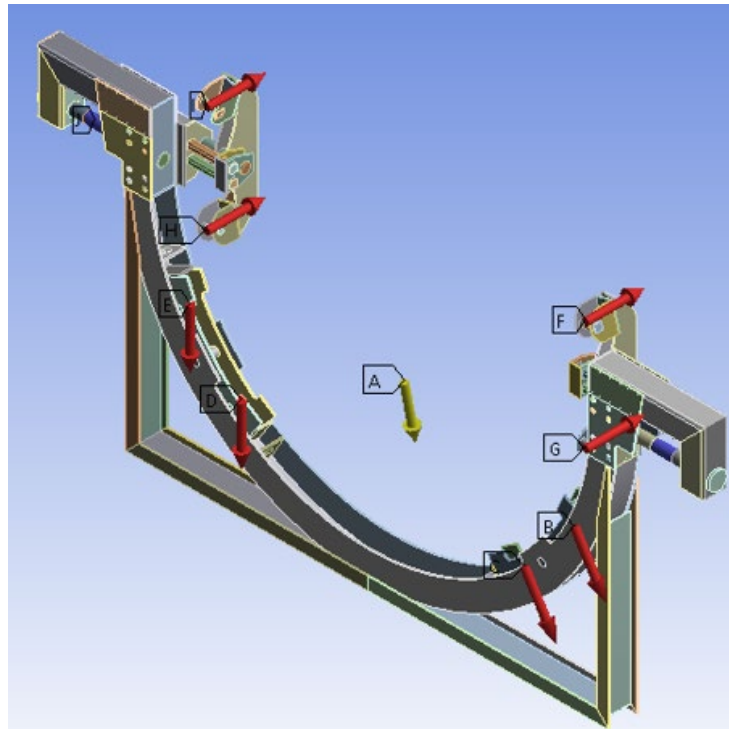
**Figure 41. Constraints and Load Plot for Hoop**

Figure 42 shows the Von Mises stress plot for the cradles under a loading condition with the vehicle raised to full height and under an 80-mph wind loading condition. The maximum stress of 38,000 psi occurs at the pin bearing at the point of rotation. This is an acceptable level of stress for this pin.



**Figure 42. Von Mises Stress Plot for Cradle**

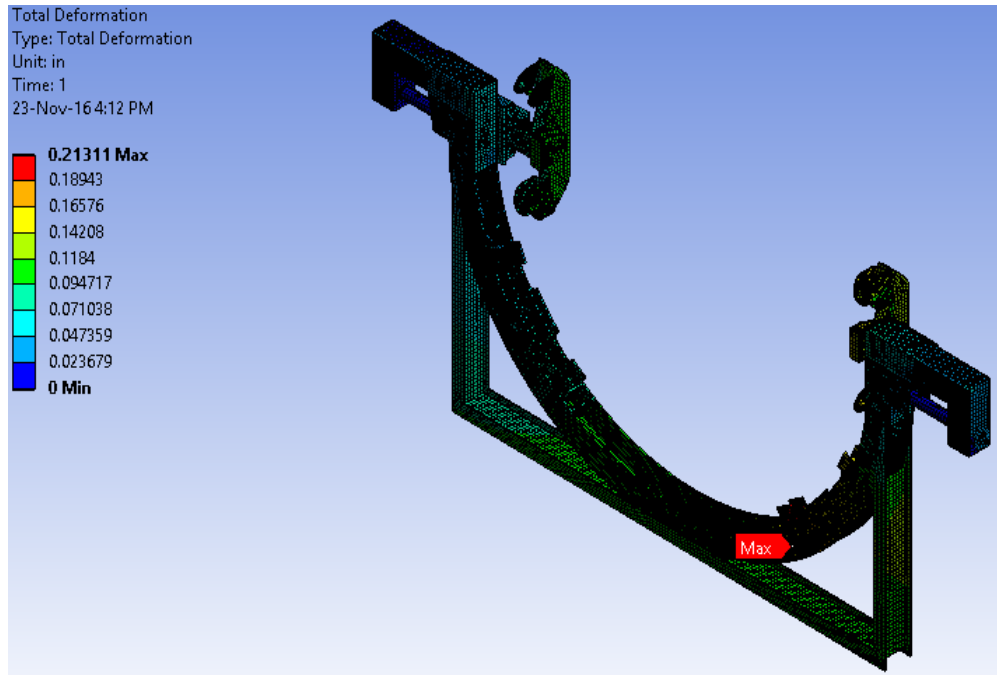
Figure 43 shows the constraints and loads associated with the stress plot in Figure 42.



**Figure 43. Constraint and Loading Plot for Cradle**

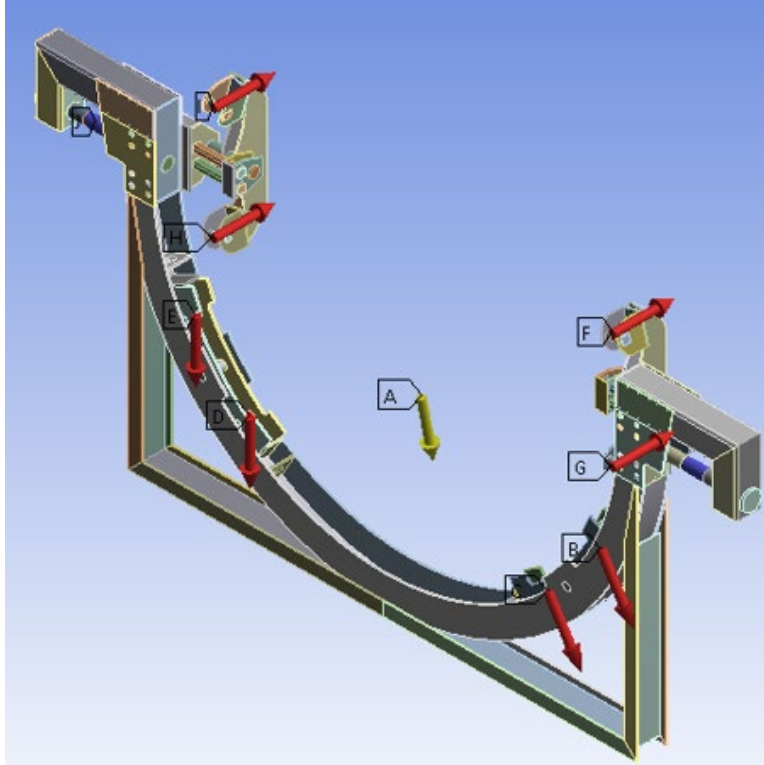
Figure 44 shows the deformation plot for the cradle under a loading condition with the vehicle raised to full height and under an 80-mph wind loading condition. The maximum deformation of

0.21 inches occurs near the walking beam pin location. This deformation is within acceptable limits.



**Figure 44. Deformation Plot for Cradle**

Figure 45 shows the constraints and loads associated with the deformation plot in Figure 44.



**Figure 45. Constraints and Load Plot for Hoop**

## 6. Cost Estimate for Facility Construction

---

The rough order of magnitude cost estimate for the construction of the bi-level rollover rig is summarized in [Table 3](#). These costs were estimated in the following manner:

- The cost of steel weldments was estimated to be five times the weight of the parts in pounds.
- The cost of fabricated parts was estimated from experience with similar parts.
- The cost of purchased parts was estimated through discussion with vendors.
- The cost of site materials was estimated from published material costs.
- The cost of site labor was estimated using standard labor rates and anticipated levels of effort.
- Heavy equipment rental costs were estimated from published rates by Sunbelt Rentals.
- Travel costs were estimated using government per diem rates for Los Angeles and current air fares.
- Engineering labor was estimated using actual ENSCO engineering rates.

**Table 3. Cost Estimate for Construction of Bi-Level Rollover Rig**

<b>Cost Element</b>	<b>Estimated Cost</b>
<b>Materials</b>	
Weldments and Fabricated Parts	\$436,300
Purchased Parts	\$132,700
Site and Concrete Materials	\$137,200
<b>Subtotal, Materials</b>	<b>\$706,200</b>
<b>Other Direct Costs (ODCs) and Subcontracts</b>	
Subcontract - Site Work Labor and Heavy Equipment	\$245,900
Travel	\$54,200
<b>Subtotal, ODCs and Subcontracts</b>	<b>\$300,100</b>
<b>Direct Labor</b>	
Engineering Labor	\$340,000
<b><i>Total Estimated Cost</i></b>	<b><i>\$1,346,300</i></b>

The following assumptions were made during the development of this rough order of magnitude cost estimate:

- Vehicle will be supplied free of charge by Amtrak
- Vehicle will be shipped to Amtrak's Los Angeles Yard at no cost to the build project
- Power will be run to the site at a designated hookup location by Amtrak at no cost to the build project

- A storm drain hookup is located adjacent to the site or will be run to the site by Amtrak at no cost to the build project
- All permitting will be handled by Amtrak
- Work will be started in calendar year 2017

## 7. Scheduling for Facility Construction

---

The schedule for the construction of the bi-level rollover rig is shown in [Figure 46](#). [Table 4](#) provides a list of the major milestones and their delivery schedule.

**Table 4. Major Milestones Schedule**

<b>Item</b>	<b>Milestone</b>	<b>Completion Months After Project Start</b>
1	Design Cleanup and Finalization	1
2	Delivery of Vehicle to Site	3
3	Subcontract Bidding and Award Process	5
4	Fabrication and Parts Procurement	9
5	On-Site Construction	10
6	Installation and Test	11



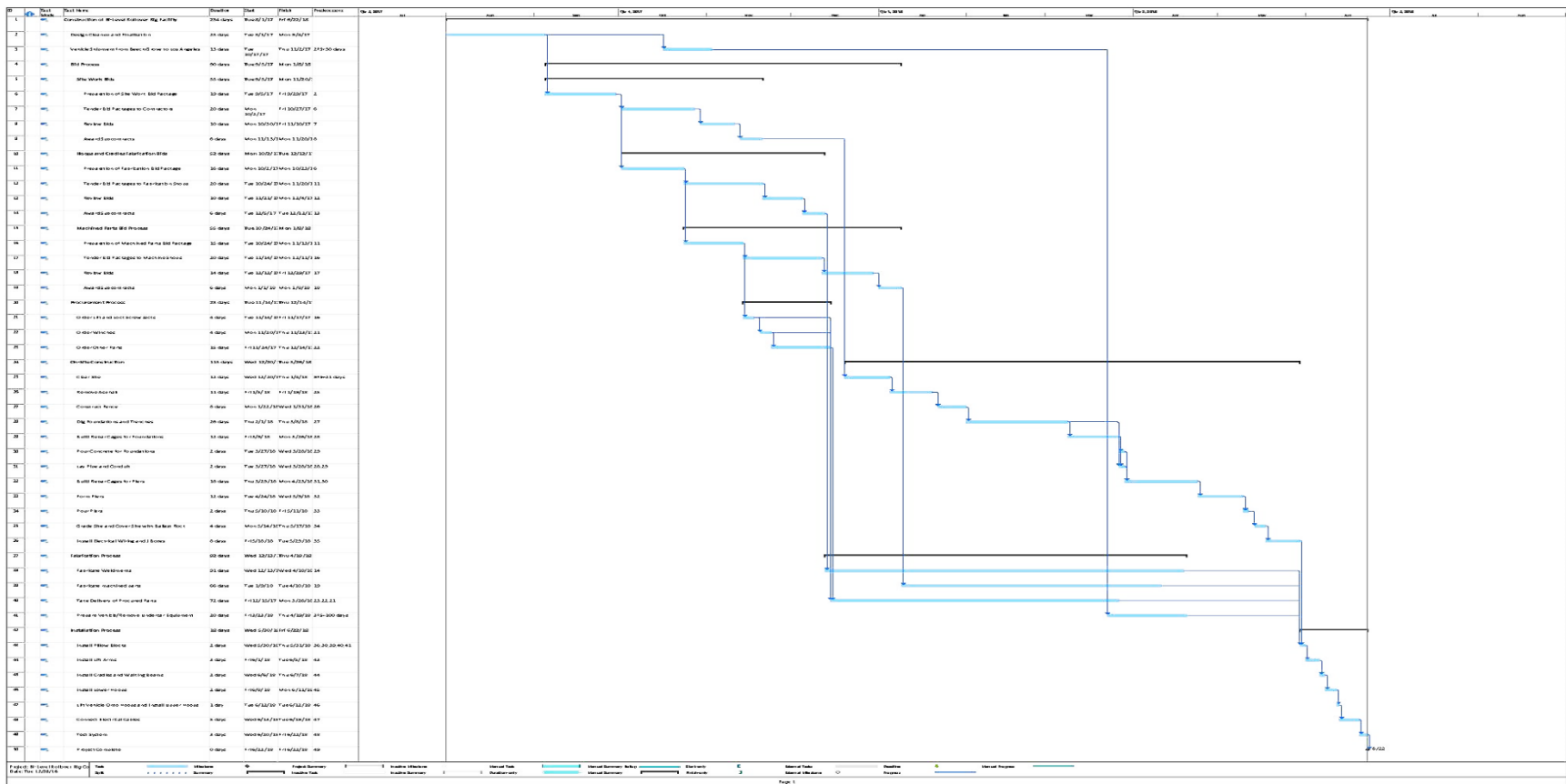


Figure 46. Full Construction Schedule for Bi-Level Rollover Rig

## 8. Drawing Lists

---

This section shows a full-size version of the schedule that was included with the portfolio of drawings shown in [Table 5](#) through [Table 10](#).

**Table 5. Loading Arm Drawing List**

<b>Drawing Number</b>	<b>Name of the Drawing</b>
ME-IASY-0004529	LIFT ARM WELDMENT, TOP
ME-IASY-0004530	LIFT ARM ASSEMBLY, BOTTOM
ME-IASY-0004527	ACTUATOR MOUNT
ME-IASY-0004528	ROD END WELDMENT
ME-PART-0004607	BUSHING
ME-IASY-0004533	WELDMENT PIN
ME-ASSY-0004619	PIN ASSEMBLY

**Table 6. Hoop Drawing List**

<b>Drawing Number</b>	<b>Name of the Drawing</b>
ME-IASY-0004505	HOOP FRAME
ME-PART-0004614	PIN SET
ME-PART-0004615	PIN CAPS
ME-PART-0004513	CLAMP RING WASHER PLATE
ME-ASSY-0004517	SIDE CLAMP ASSY
ME-PART-0004506	SIDE CLAMP
ME-PART-0004514	SIDE CLAMP SPACER TUBE
ME-ASSY-0004518	LOWER CLAMP ASSY
ME-PART-0004507	LOWER SIDE CLAMP
ME-PART-0004640	CLEVIS BLOCK
ME-PART-0004641	CLEVIS BLOCK
ME-PART-0004639	CLEVIS
ME-PART-0004644	CLEVIS
ME-ASSY-0004642	CABLE TENSION CLEVIS
ME-PART-0004614	PIN SET
ME-PART-0004615	PIN CAPS
ME-ASSY-0004619	PIN ASSEMBLY
ME-PART-0004634	SUPPORT PLATE

**Table 7. Cradle Drawing List**

<b>Drawing Number</b>	<b>Name of the Drawing</b>
ME-PART-0004516	RING FIT AND TEST ASSEMBLY

<b>Drawing Number</b>	<b>Name of the Drawing</b>
ME-IASY-0004637	CARRIAGE FRAME
ME-ASSY-0004619	PIN ASSEMBLY

**Table 8. Vertical Walking Beam Drawing List**

<b>Drawing Number</b>	<b>Name of the Drawing</b>
ME-PART-0004628	BUSHING RACE
ME-IASY-0004631	LATERAL WALKING FRAME
ME-PART-0004610	WHEEL
ME-ASSY-0004609	ROLLER ASSEMBLY
ME-PART-0004625	RETAINING RING
ME-PART-0004613	CAPTURE RING
ME-PART-0004614	PIN SET
ME-ASSY-0004601	VERTICAL WALKING BEAM ASSEMBLY
ME-ASSY-0004619	PIN ASSEMBLY

**Table 9. Longitudinal Walking Beam Drawing List**

<b>Drawing Number</b>	<b>Name of the Drawing</b>
ME-IASY-0004633	LONGITUDINAL WALKING BEAM ASSY
ME-IASY-0004602	LATERAL SUPPORT
ME-PART-0004607	BUSHING
ME-PART-0004625	RETAINING RING
ME-PART-0004613	CAPTURE RING
ME-PART-0004628	BUSHING RACE
ME-ASSY-0004609	ROLLER ASSEMBLY
ME-PART-0004610	WHEEL
ME-IASY-0004604	WALKING BEAM FRAME
ME-IASY-0004605	CASTER FRAME
ME-PART-0004614	PIN SET
ME-PART-0004615	PIN CAPS
ME-PART-0004628	BUSHING RACE
ME-ASSY-0004619	PIN ASSEMBLY

**Table 10. Concrete Foundation and Site Layout Drawing List**

<b>Drawing Number</b>	<b>Name of the Drawing</b>
ME-LOUT-0004593	SITE LAYOUT
ME-ASSY-0004647	RING ASSEMBLY
ME-PART-0004634	SUPPORT PLATE

## 9. Conclusion

---

FRA developed the design for a bi-level emergency evacuation simulation facility also known as the bi-level rollover rig. This facility will provide the passenger railroad community with a training tool for first responders to develop the additional skills need to assist in the evacuation of bi-level rail cars involved in train accidents/derailments. When this facility is built it will also be a tool for evaluating the applicability of time-based egress computer models to passenger rail cars and the possible refinement of such models. The benefit of such a device is that it can be used to train thousands of railroad employees, emergency responders, including area fire fighters, paramedics, military personnel, and law enforcement during evacuations of passengers from overturned rail cars.

In discussion with FRA and Amtrak, requirements were established for the bi-level rollover rig in which four concepts of basic design were developed and are as follows:

1. Rotisserie on Bridge
2. Rotisserie on Earthworks
3. Hoops on Earthworks
4. Hoops on Bridge
5. Hoops on Earthworks

Under the support of FRA and Amtrak's design concepts, ENSCO developed the construction requirements of the training facility's design and location. This facility will provide a realistic and safe environment to train railroad employees and first responders using the rollover rig.

## **Abbreviations and Acronyms**

---

<b>ACRONYMS</b>	<b>EXPLANATION</b>
CG	Center of Gravity
FRA	Federal Railroad Administration
ODCs	Other Direct Costs
WMATA	Washington Metropolitan Area Transit Authority