

Attachment D
Comments Received

Comments from General Public

PUBLIC SUBMISSION

As of: November 29, 2022
Received: November 25, 2022
Status: Posted
Posted: November 28, 2022
Category: Decision / Response
Tracking No. law-qjr5-iu4t
Submission Type: Web

Docket: FRA-2022-0090

Brightline West Cajon Pass High-Speed Rail Project Environmental Assessment

Comment On: FRA-2022-0090-0001

Brightline West Cajon Pass Environmental Assessment -Final

Document: FRA-2022-0090-0015

Comment from Doug Sawyer

Submitter Information

Name: Doug Sawyer

Address:

CA, 92861

General Comment

As a resident of SoCal and a frequent traveler in the IE, the value of BrightlineWest is profound. Reduced traffic, reduced emissions, enhanced TOD and improved jobs are just a few of the strong benefits. Truck traffic has increased so much in the last decade, causing more difficult driving conditions and safety concerns. Ways for a private-public development to improve this 228-mile long corridor r much appreciated. It will increase the likelihood of future trips to LV. Plz move forward with this critical project.

PUBLIC SUBMISSION

As of: November 29, 2022
Received: November 15, 2022
Status: Posted
Posted: November 17, 2022
Category: Public Comment(s)
Tracking No. laj-3xar-gw2a
Submission Type: Web

Docket: FRA-2022-0090

Brightline West Cajon Pass High-Speed Rail Project Environmental Assessment

Comment On: FRA-2022-0090-0001

Brightline West Cajon Pass Environmental Assessment -Final

Document: FRA-2022-0090-0007

Comment from Elizabeth Lopez

Submitter Information

Name: Elizabeth Lopez

Address:

Etiwanda, CA, 91739

Email: el0554776@gmail.com

General Comment

I'm writing in regard to the Notice of the Brightline West Cajon Environmental Assessment- EA. I 'm asking for an extension to make comments. The deadline to submit comments is on Monday, November 28,2022 and Thanksgiving Day many people have made other commitments at this time. Could we have more time to submit our comments? Thank you for your time in this matter.



Federal Railroad Administration Committee Members:

As a past Chairman of the Board of Supervisors of San Bernardino County, I am pleased to share my support for the Brightline West project.

I had the opportunity to visit the successful and dynamic Brightline High Speed Rail project in Florida, ride the rails and learn about this vibrant company.

In our region, the I-15 Freeway serves as a link between Southern California and Nevada. I-15 also serves as a daily commuter roadway from the high desert to LA, Orange, Riverside, San Diego Counties. Families moving to the high desert seeking affordable housing have added to the already heavy commuter traffic. Consequences of these issues are heavy and dangerous traffic conditions, pollution, and frustration for those traveling Interstate 15. I-15 through the Cajon Pass has recently been identified as one of the most dangerous freeways. This coupled with heavy vacation trip and truck traffic to Las Vegas, Arizona and Utah adds to the congestion and danger. Nearly 50% of the US freight arrives at the Ports of Los Angeles and is transported by truck on our interstate freeways.

We were delighted to learn that Brightline West introduced a transformational project that will significantly enhance connectivity through the I-15 corridor, reduce emissions and congestion, create jobs, and spur economic activity in surrounding communities.

As a high-speed rail line, Brightline West would be a critical solution to alleviating traffic and providing millions of people with a cleaner, safer, and more efficient way to travel using an all-electric, zero-transmission trainsets that can be used by travelers and commuters. The advantages of coupling the Brightline West trains with existing Metrolink lines is a incredible bonus for this project.

Brightline West is part of an organization that has already proven the capabilities of privately owned passenger rail in the US through the Brightline system in Florida, which opened in 2018.

Based on the assets already mentioned, Brightline West has the ability to finish the project quickly, enhancing the lives of commuters, truckdrivers and visitors.

I ask that you consider the greater environmental enhancements that this project offers and vote to approve the environmental impact report.

Yours sincerely,

A handwritten signature in black ink, appearing to read "Robert A. Lovingood".

Robert A. Lovingood

PUBLIC SUBMISSION

As of: November 29, 2022
Received: November 11, 2022
Status: Posted
Posted: November 15, 2022
Tracking No. lac-xaya-avh4
Submission Type: Web

Docket: FRA-2022-0090

Brightline West Cajon Pass High-Speed Rail Project Environmental Assessment

Comment On: FRA-2022-0090-0001

Brightline West Cajon Pass Environmental Assessment -Final

Document: FRA-2022-0090-0004

Comment from james maugé

Submitter Information

Name: james maugé

Address:

hermosa beach, CA, 90254

Email: jimmauge@gmail.com

Phone: 13107228692

General Comment

I believe the Brightline West all electric , high speed rail will be transformative for Southern Calif, especially the Inland Empire . There are numerous and very significant economic , environmental and community benefits . California needs this project

PUBLIC SUBMISSION

As of: November 29, 2022
Received: November 16, 2022
Status: Posted
Posted: November 17, 2022
Category: Public Comment(s)
Tracking No. lak-4f0j-llwh
Submission Type: Web

Docket: FRA-2022-0090

Brightline West Cajon Pass High-Speed Rail Project Environmental Assessment

Comment On: FRA-2022-0090-0001

Brightline West Cajon Pass Environmental Assessment -Final

Document: FRA-2022-0090-0008

Comment from Economics & Politics, Inc.

Submitter Information

Email: john@johnhusing.com

Organization: Economics & Politics, Inc.

General Comment

Last year, Economics & Politics, Inc. completed a major study of the issues facing residents of the High Desert of San Bernardino County (Victorville, Apple Valley, Hesperia area). This involved a detailed look at economic and demographic data on the area as well as one-on-one interviews with 50 community leaders from business, government, farming, real estate, education and interest groups. The unanimous agreement among the leaders was that the lack of ability of workers to get down the I-15 to jobs in any timely manner was a major issue for the area. The data on commuter lengths of time to work for people living in the area supported that view. One recommendation of the study was for a rail connection to be made of exactly the route proposed for the connection down to Rancho Cucamonga. I strongly support this project.

John Husing

Economics & Politics, Inc.

PUBLIC SUBMISSION

As of: November 29, 2022
Received: November 16, 2022
Status: Posted
Posted: November 17, 2022
Category: Public Comment(s)
Tracking No. lak-bt83-d42w
Submission Type: Web

Docket: FRA-2022-0090
Brightline West Cajon Pass High-Speed Rail Project Environmental Assessment

Comment On: FRA-2022-0090-0001
Brightline West Cajon Pass Environmental Assessment -Final

Document: FRA-2022-0090-0010
Comment from Anthony Titolo

Submitter Information

Name: Anthony Titolo
Address:
Huntington Beach, CA, 92646
Email: tonyt@frontlineunited.com
Phone: 714-733-7078

General Comment

As a long time property owner in the Victor Valley area, I support the development of the Brightline West high speed rail project. This project will provide a viable transportation option for residents of Southern California who are traveling to Las Vegas.

PUBLIC SUBMISSION

As of: November 29, 2022
Received: November 14, 2022
Status: Posted
Posted: November 15, 2022
Category: Other
Tracking No. lah-g5gx-3hly
Submission Type: Web

Docket: FRA-2022-0090
Brightline West Cajon Pass High-Speed Rail Project Environmental Assessment

Comment On: FRA-2022-0090-0001
Brightline West Cajon Pass Environmental Assessment -Final

Document: FRA-2022-0090-0005
Comment from Anonymous

Submitter Information

Name: Anonymous Anonymous
Email: swilson@circamgt.com

General Comment

I think the rail project will allow for needed growth and support the green new deal.

PUBLIC SUBMISSION

As of: November 29, 2022
Received: November 28, 2022
Status: Posted
Posted: November 29, 2022
Category: Public Comment(s)
Tracking No. lb1-91v9-w20x
Submission Type: Web

Docket: FRA-2022-0090

Brightline West Cajon Pass High-Speed Rail Project Environmental Assessment

Comment On: FRA-2022-0090-0001

Brightline West Cajon Pass Environmental Assessment -Final

Document: FRA-2022-0090-0020

Comment from Anonymous

Submitter Information

Name: Anonymous Anonymous

Email: jkaufer3@yahoo.com

General Comment

With ongoing housing and industrial development in the HD and a positive outlook for future growth in the area, there is an urgent need to address the many challenges this growth is creating. Road systems, traffic congestion and vehicle capacity on a limited travel grid, coupled with no feasible public transportation system within the region is a major issue. The Cajon pass is the only thoroughfare between the Inland Empire valley and the eastern range of the San Bernardino and San Gabriel mountain ranges. Many people live in the HD and commute and with no other way of travel for work or moving goods between the valley and much of the eastern part of the country. With the volume of current and future traffic in the pass, it easily becomes congested and in cases of natural disasters such as the seasonal fires that shut the pass down, the two regions are completely cut off. We need an alternative means of travel between the two regions and with the rail system already in place, a brightline train is something that should be explored.

Verbal Public Comment Transcripts

Speaker: Paul Tescon (Corrected from Texan)

Date of Comment: November 12, 2022 on Zoom

Comment:

“Can you hear me? My name is Paul Texan. I'm from Corona and Las Vegas I lived in both areas. My office is in Ontario. I just got back from Miami and I purposely rode the Brightline train from Miami to West Palm Beach via Fort Lauderdale. This is something we need. They are actually gonna be finishing soon to Orlando. I'm anxiously awaiting the approval of this. As for my question; I'm 100% in full support and have been waiting close to a decade when it first started as DesertXpress and now Brightline West. On the EA, has it been completed from going to LA? That's the first question I have, there's a lot of separate links I need to look at. The second question I have is, once the period is over and you get Record of Decision, is that the point where Brightline West can break ground? As long as they have the funding and I guess, private decision? Is that where it stops? So thank you for this meeting. Appreciate it, thank you.”

Verbal Public Comment Transcripts

Speaker: Marcus Nelson

Date of Comment: November 15, 2022, on Zoom

Comment:

“Sorry. Sorry about that. Marcus Nelson, Jacksonville Florida. As someone from a state that it is currently operating in this expanding service, I want to really express my support for this project. We have seen that it has a proven track record of building these express paths especially on highway right of way. It is something that they have already done and already worked with.

I think it shows that they are more than capable of bringing this project to completion. In a manner that is responsible for their environment. And responsible to the needs of the community. Especially the fact that they are bringing high-speed electric multiple unit trains to America on a fast timeline, I think it's really demonstrative of how this project brings value to the community. Including its local service to Hesperia. I really just want to say that especially as we see in the report, how it does not have a negative effect on the environment.

This project seems positive and I hope to see it coming to fruition. Thank you.”

Verbal Public Comment Transcripts

Speaker: Tricia Almiron

Date of Comment: November 15, 2022, on Zoom

Comment:

“Thank you good evening. Can you hear me? Thank you. I will try to be as concise as possible. My name is Tricia and I am a city employee with the city of Ontario, California here on behalf of the city manager, and city councilmembers. We are in support of this project for several reasons.

The first one being safety. By reducing the vehicle traffic coming up and down on I-15 and giving folks an opportunity to take transit and not commute hours per day with the semi trucks up and down the pass. This is a win.

This also helps the air quality. We are currently not in attainment with the federal attainment goals. In addition to reducing the travel, we are looking out alternative ways for residents and passengers to get to the Ontario international Airport. This would provide a critical link to the entire higher basin in the region. Workers and residents can get to Ontario international Airport via transit.

Lastly, we are working with our sister city to the north to explore additional housing around that TOD site, where the Brightline will terminate. This housing is critical for the region as we also are not meeting the numbers that the state has required us. Those are all my comments.”

Verbal Public Comment Transcripts

Speaker: Andy Kunz (Corrected from Lunz)

Date of Comment: November 15, 2022, on Zoom

Comment:

"I am Andy Lunz, I want to express our support for this project as well. This is probably one of the most important high-speed rail projects in America right now. And in the history of our country as it will really be one of the first to demonstrate what fast trains, fast electric trains are really like.

As was said earlier, Brightline already has a record of doing exceptional service and raising a whole bar of what train travel is all about. And how exceptional the experience it can be.

We back a lot on this project that this is really going to change a lot of travel patterns, make rail much more friendly to the United States and more available to people and we supported fully. We recommend that the full passing of this project is getting billed as soon as possible. Thank you so much."

Verbal Public Comment Transcripts

Speaker: Otis Greer

Date of Comment: November 15, 2022, on Zoom

Comment:

“Good evening and thank you for the opportunity to express our support for this project. This project is extremely important not just for the benefit of the traveling public in and through San Bernardino County to the Nevada stop, but the service will provide an amazing opportunity to offer a connection for residents of the high desert to a Metrolink network train network station in Rancho Cucamonga. This is a service that our agency may not have been able to provide on its own.

This amazing opportunity for public/private partnership that will give us the benefit of a great service, a connection that will eventually lead to a connection to the Ontario international Airport. Connections to Los Angeles Union Station, to the west and to the city to the east. With the University of Redlands, Esri campus as well as downtown Redland, San Bernardino, and so forth.

This is a great network system that we are excited to support and delighted to be partners with the Brightline West team. Thank you very much.”

Comments from Elected Officials



County of San Bernardino
Board of Supervisors
First District

385 N. ARROWHEAD AVE, FIFTH FLOOR
SAN BERNARDINO, CA 92415
(909) 387-4830

November 17, 2022

Matthew Mielke, Environmental Protection Specialist
Environmental Review Division
Federal Railroad Administration
1200 New Jersey Avenue, SE
West Building, Mail Stop 20
Washington, DC 20590

Dear Matthew Mielke,

As First District Supervisor for San Bernardino County, I write this letter to express my support for the Brightline West Project. This project represents a key opportunity to improve our region's connectivity, spur economic development, and reduce carbon emissions.

Everyday thousands of my constituents commute from their homes to jobs throughout the Inland Empire and Southern California. This project will not only decrease commute times for many of my constituents, but will also reduce the number of vehicles that utilize this stretch of the I-15, resulting in cleaner air and less emissions. This project will also create thousands of jobs and inject millions of dollars into our local economy, while at the same time increasing the connectivity of our region and reducing vehicle miles traveled.

I am proud to support this project, and hope that the Committee does as well. Should you have any questions, please contact my office at (760) 995-8100.

Sincerely,

Col. Paul Cook (Ret.)
First District Supervisor, San Bernardino County

PUBLIC SUBMISSION

As of: November 29, 2022
Received: November 16, 2022
Status: Posted
Posted: November 17, 2022
Category: Public Comment(s)
Tracking No. lak-4rd4-iopf
Submission Type: Web

Docket: FRA-2022-0090

Brightline West Cajon Pass High-Speed Rail Project Environmental Assessment

Comment On: FRA-2022-0090-0001

Brightline West Cajon Pass Environmental Assessment -Final

Document: FRA-2022-0090-0009

Comment from City of Victorville

Submitter Information

Email: dsjones@victorvilleca.gov

Government Agency Type: Local

Government Agency: City of Victorville

General Comment

Hello.

I'm Victorville Mayor Debra Jones, and I'm pleased to have this opportunity to support Brightline West.

This high-speed rail line will have great benefit for our region.

Brightline West will be good for our environment, our economy, and our way of life.

The all-electric, zero-emission trainsets will remove millions of cars and tons of CO2 from our atmosphere every ear.

We will experience reduced congestion on the I-15, which reduces emissions and increases safety on this busy interstate.

The connectivity to the High Desert Region where Victorville is located will provide our residents more convenient commuter options and access to Los Angeles and Las Vegas and increase business opportunities in our local economy.

Additionally, Brightline West will create thousands of jobs for our residents while infusing investment in our economy.

Once again, I'm pleased to voice support for Brightline West on behalf of the City of Victorville.

Verbal Public Comment Transcripts

Speaker: Art Bishop, Mayor Pro Tem Town of Apple Valley

Date of Comment: November 12, 2022 on Zoom

Comment:

"Can you hear me? Good morning. Good morning from California. My name is Art Bishop. I am the mayor pro tem for the town of Apple Valley and I'm also the president of the San Bernardino Transportation Authority and the VP of League of Cities Desert Mountain Division. I am speaking on behalf of all these agencies and I am here to mention that we are in full support for the Brightline West for the passenger rail line from the Victor Valley to Rancho Cucamonga portion of the project.

We are in support for some of the following reasons.

One of the things I really excited about is that my region has a population of approximately 500,000 people. We are up the hill, about 63% of my people that work down the hill, have to commute through the Cajon path. The station will be a transit, a commuter rail, which will allow people to take the train from the high desert down to Rancho Cucamonga, and be able to go to work. We are extremely excited about that.

Brightline West is a transformational project which will enhance connection through the I-15 corridor, reducing emissions, congestion, will create jobs, and spur economic activity in these regions. The high-speed rail line will be a critical solution and alternative to traffic in providing millions of people with a cleaner, safer and more effective way to travel.

Brightline West is part of an organization that is already proven the capabilities of privately owned passenger rail in the US through the Brightline system in Florida which opened in 2018. I will mention, I have personally been able to ride the Brightline West train in Florida and found it to be an absolutely fantastic program.

Brightline West will use an all-electric zero emissions train set which will remove millions of cars and tons of CO2 from the atmosphere every year. It will also significantly reduce vehicle miles traveled annually, helping both California and Nevada realize their respective emission control to improve the safety corridor.

The alignment enhances safety through the corridor, not only by reducing traffic, but having zero crossings and operating in its own protective dedicated rail corridor within the I-15 corridor.

The total economic impacts of Brightline West system between Las Vegas and Southern California is an estimated 10 billion, with 1 billion in tax revenue annually. Representing a significant opportunity for private investment in a very critical movement both for California and Nevada"

Comments from Government Agencies



Office of Intergovernmental Affairs

November 28, 2022

Matthew Mielke
Project Manager
Federal Railroad Administration
1200 New Jersey Avenue, SE
Washington, DC 20590

RE: Brightline West Cajon Pass High-Speed Rail Project Environmental Assessment

Dear Mr. Mielke,

The San Manuel Band of Mission Indians (SMBMI) appreciate the opportunity to provide public comment on the Environmental Assessment (EA) for the proposed Brightline West Cajon Pass High-Speed Rail Project, pursuant to the National Environmental Policy Act (NEPA). The Federal Railroad Administration (FRA) has worked closely with the Tribe's Cultural Resources Management (CRM) Department on the subject of the proposed project and is well aware of the deep cultural connection that the Tribe has to the project area; most specifically the Cajon Pass.

While we appreciate the ongoing consultation with the FRA, as well as the opportunity to provide previous comments on October 6, 2022, it appears that few, if any, of our comments were adequately addressed despite several sections of the EA stating the FRA made considerations based on the result of Tribal consultation. Below, please find a general summary that outlines and reiterates some of our outstanding concerns:

- The 30-day public commenting period fell over the Thanksgiving holiday, which may result in fewer opportunities for member of the public to review the EA. It is our recommendation that the comment period be extended.
- **The comment that "FRA did not identify any archeological resources or tribal cultural resources within 200 feet of the rail alignment" is inaccurate.** Also, several statements about lack of awareness of cultural activities that would occur within 200 feet of the alignment are inaccurate as well (these subjects have been discussed several times throughout consultation).
- Multiple areas of the EA note that review/assessment of a resource, such as plant and desert tortoise surveys, will occur at a later date. However, the FRA has concluded that there will be no significant impacts to resources prior to conducting their review/assessment. We don't understand how the FRA was able to conclude that there will be no significant impact to resources without first conducting a review/assessment of those resources.

- The Noise and Vibration Study locations were considered based on geology and proximity to private residences. No locations were selected based on proximity to archaeological sites or cultural landscapes. The study should also look at the unique and specific impacts of noise and vibration on archaeological sites and cultural landscapes, which should include assessment for each of the NRHP-eligible sites and/or districts noted within the project area. This, as well as more confidential details, was pointed out in the comments provided in October.
- FRA continues to focus on impacts to Tribal activities and practices in their assessment for certain resource categories, such as noise. While the inclusion is appreciated, cultural setting is about the overall sensitivity of the landscape, from sacred areas to ancestors, that require additional consideration beyond “activities.” This also was noted in the comments provided in October.
- The Tribe continues to be concerned by the premature assessment concluding that the project will not have a significant impact to cultural resources given:
 - o FRA continues to struggle with the inclusivity of cultural landscapes in their delineation of the Area of Potential Effect (APE) (referenced on under 4.7.2) and assessment of project-based impacts.
 - o Archaeological due diligence for the project continues to be a problem.
 - o Tribal consultation to both identify and minimize impacts to cultural resources is still ongoing.
 - o Information related to the project footprint and construction is still far too general, and the lack of specific information prevents FRA from properly identifying potential impacts to identified resources as a result of the project, specifically those of concern and cultural importance to the Tribe.

All notes above on this subject were provided in the October comments.

At this time, the Tribe still has many concerns related to FRA’s approach to this project, primarily as it relates to lack of due diligence for resource identification and assessment of impacts to said resources. It is our hope that our concerns will be resolved as we continue to move forward in the consultation process.

Should FRA have any immediate questions regarding the Tribe’s public comments on the EA, please do not hesitate to contact Jessica Mauck, Director of Cultural Resources Management at jessica.mauck@sanmanuel-nsn.gov.

Thank you again for the opportunity to provide comments and highlight San Manuel’s unique and deep ties to the landscape on which the project is planned to occur. The Tribe looks forward to continued discussions with FRA on the subject.

Respectfully,



Daniel Little
Chief Intergovernmental Affairs Officer

November 17, 2022

Mr. Art Bishop, President
SBCTA
1170 W. Third Street
San Bernardino, CA 92410

RE: Support for the Brightline West Project

Dear Mr. Bishop,

The Town of Yucca Valley is in full support of the Victor Valley to Rancho Cucamonga portion of the Brightline West Project. This project will not only significantly enhance connectivity through the I-15 corridor, but it will also reduce emissions and traffic congestion, create jobs, and spur economic activity in the surrounding communities. The benefit of providing residents of Southern California with access to high-speed rail service to Las Vegas, as well as access for residents of the High Desert to job centers in the San Bernardino Valley and greater Los Angeles is a win-win for all.

The reduction of the traffic congestion on the I-15 corridor through the Victor Valley and Cajon Pass will also have a direct benefit to the Town of Yucca Valley due to the reduction of ancillary vehicle trips that utilize SR 247 through Yucca Valley as an alternative route. This development will also reduce individual vehicle trips from Southern California to Las Vegas, and similar spill-over traffic through the Morongo Basin. Such improvements would positively impact traffic circulation, air quality metrics, and the long-term sustainability of both new and existing transportation infrastructure.

Therefore, the Town of Yucca Valley fully supports the Brightline West Project and its many benefits for residents and the environment.

Sincerely,

Curtis Yakimow
Town Manager
Town of Yucca Valley



The Town of
Yucca Valley

57090 Twentynine Palms Highway • Yucca Valley, California 92284
760/369-7207 • Fax (760) 369-0626

PUBLIC SUBMISSION

As of: November 29, 2022
Received: November 17, 2022
Status: Posted
Posted: November 21, 2022
Category: Supporting / Supplement Material(s)
Tracking No. lal-ninz-vicb
Submission Type: Web

Docket: FRA-2022-0090
Brightline West Cajon Pass High-Speed Rail Project Environmental Assessment

Comment On: FRA-2022-0090-0001
Brightline West Cajon Pass Environmental Assessment -Final

Document: FRA-2022-0090-0011
Comment from Town of Yucca Valley

Submitter Information

Email: jrice@yucca-valley.org
Government Agency Type: Local
Government Agency: Town of Yucca Valley

General Comment

The Town of Yucca Valley is in full support of the Brightline West Project as indicated in the attached support letter.

Attachments

Letter of Support for the Brightline West Project 11.17.22



November 28, 2022

ELECTRONIC SUBMISSION VIA REGULATIONS.GOV

Federal Railroad Administration
United States Department of Transportation
1200 New Jersey Ave., SE
Washington, DC 20590
Attention: Matthew Mielke
matthew.mielke@dot.gov

Re: City of Rancho Cucamonga Comments to Brightline West - Cajon Pass High-Speed Rail Project Environmental Assessment (Docket FRA-2022-0090)

The City of Rancho Cucamonga (“City”) submits the following comments to the Federal Railroad Administration’s draft Environmental Assessment (“EA”) for the Brightline West - Cajon Pass High-Speed Rail Project (“Project”). The Project is to construct a 49-mile high-speed rail line connecting Rancho Cucamonga, California to the 180-mile high-speed rail project between Las Vegas and the Victor Valley, along the I-15 freeway corridor, including adding a high-speed rail station at the existing Metrolink station in Rancho Cucamonga’s HART District.

The City is pleased that Brightline West has selected Rancho Cucamonga as the southern terminus for its high-speed rail line. The City has extensively worked with Brightline West over the past several years to facilitate the real estate transactions and development requirements for the proposed Rancho Cucamonga high-speed rail station, which will be located on property jointly owned by the City and the San Bernardino County Transportation Authority (“SBCTA”). On October 4, 2022, the City Council approved a development and disposition agreement (“DDA”) with SBCTA and Brightline West for the project site. The DDA also conveyed track easements along the City’s right-of-way. The City looks forward to working with Brightline West to implement the DDA and deliver this important interstate and regional rail project.

As explained in greater detail below, the Project described in the EA and certain mitigation proposed in the EA are not necessarily completely consistent with the terms the City has negotiated with Brightline West, in particular with respect to the use of certain City property near the station. The City requests that the Federal Railroad Administration consider amending the EA to make the Project, and all mitigation, consistent with the terms negotiated between Brightline West and the City and to reflect the City’s plans for certain property near the station. The City also provides comments to better address traffic related impacts, improve efficacy of required mitigation, and add clarity to the analysis in the EA.

A. Unacceptable Use of City Property for Traction Power Substation

City Property not Available for Traction Power Substation – Section 4.8.5.2 of the EA states, “In the City of Rancho Cucamonga, a traction power substation will be located next to I-15 on City-owned property, designated in the Victoria Community Plan as ‘Regional Related Office/Commercial.’” EA Section 4.8.5.2, at 123. The property referenced is off Jack Benny Drive, adjacent to the I-15.

The City-owned property on Jack Benny Drive is not a part of the DDA and the City has never offered this property for a traction power substation for the Project. Based on conversations with Brightline West, we believe that the EA’s reference to the substation being located on the City-owned property is incorrect and that it will be located on non-City owned property elsewhere within the project limits. Brightline West has represented that it will not take City-owned property for Project-related use. Therefore the text should be deleted.

City Property not Available for Additional Parking – The EA also identifies expansion of existing parking facilities or construction of additional parking facilities on City-owned property adjacent to the Rancho Cucamonga station as mitigation for parking impacts from the Project. This mitigation should be removed. The referenced City property is being considered for development for housing, hospitality, and restaurant uses and is specifically not available according to agreements with Brightline West for long-term parking. Brightline West has represented that it will not take city-owned property for Project-related use. Therefore the text should be deleted. The EA indicates the following as a mitigation option if needed for future parking needs:

Providing off-site parking at existing underutilized parking facilities within 5 miles of the station, including a free shuttle for passengers who park at an off-site parking facility, and identifying any additional off-site parking facilities that are anticipated to be required within the next five years based on ridership forecasts

The City requests that the above be modified to also require that Brightline “enter into voluntary parking agreements with public and private property owners within the 5 mile radius.”

B. Safety

The DDA requires Brightline West to conform the Project to the substantive provisions of the City’s technical codes, grading standards, and all other applicable laws and regulations governing development of the Project. It also provides the Rancho Cucamonga Fire Protection District the opportunity to review and approve all design and construction plans and inspect the Project improvements. As a result, the City’s technical standards and the Rancho Cucamonga Fire Protection District’s Fire Standards should be listed in the Regulatory Setting section for Section 4.14 Safety. EA, Section 4.14.1, at 182. The Rancho Cucamonga Fire Protection District is charged with fire protection and emergency response within the City of Rancho Cucamonga and therefore the District’s Fire Standards are relevant to the Project and the area studied in the EA.

The EA notes that Brightline will “design, construct, operate and maintain the Project in accordance with all relevant Caltrans requirements” because the Project will be constructed in the Caltrans right-of-way. To the extent that Brightline will impact or have to rebuild City owned assets in the City’s right-of-way, Rancho Cucamonga requests similar treatment as Caltrans.

C. Traffic and Parking

Inadequate Mitigation of Intersection Impacts – The EA acknowledges that the Rancho Cucamonga station will degrade the level of service at the Milliken Ave./7th Street intersection compared to the 2045 No Build scenario. EA Executive Summary, at xvii. To address the impact to the intersection of Milliken Ave./7th street, the EA states that Brightline West will modify the intersection at Milliken Ave./Azusa Ct. to permit unprotected left turns into Azusa Ct. from northbound Milliken Ave. EA Section 4.12.6.1 at 173. According to the EA, a 35% diversion of left turns to Milliken Ave./Azusa Ct. from Milliken Ave./7th Street is projected for balanced traffic operations at both ingress intersection. *Id.* This mitigation measure is inconsistent with Brightline West’s commitment to both the City and SBCTA to install a full access traffic signal at this location. An unprotected left turn creates operational issues in the project area and exposes the City to liability should the unprotected left turn lane be determined to be an unsafe condition in the future. The City requests that this condition be changed to correspond to Brightline West’s commitment and to require a full access traffic signal at intersection of Milliken Ave./Azusa Court.

The EA also fails to identify and analyze additional traffic signals or other traffic control devices such as roundabouts at the intersections of Azusa Ct./Anaheim Pl. and Milliken Ave./the new Brightline West driveway. Per City standards and discussions with Brightline West, traffic control devices will be required at these two intersections. The City requests that a condition be added to the EA requiring Brightline West to analyze these locations in cooperation with the City and to design and construct the improvements at the intersections of Azusa Ct./Anaheim Pl. and Milliken Ave./the new Brightline West driveway to the City’s standards.

The EA also acknowledges that the Project will contribute traffic to three intersections (namely Milliken Ave./Foothill Blvd, Milliken Ave./4th St., and Milliken Ave./1-10 WB ramps) that are projected to operate at unacceptable levels of service during the 2045 No Build conditions. EA Executive Summary, at xvii. However, the City’s initial estimates for Milliken Avenue indicate that at some point between opening year and horizon year, the traffic on the segment of Milliken Ave. between 4th Street and Foothill Boulevard will exceed the existing capacity only under Project build conditions. This exceedance was *not* expected based on the City’s own environmental analysis in its General Plan build-out without the Project. The City requests the Project be further conditioned to require Brightline West to prepare a traffic study in cooperation with the City to determine the timing of any potential exceedance in capacity and to fund Brightline West’s fair share costs of capacity enhancement needs identified in the study. This study is also needed to better evaluate certain assumptions made in the EA analysis. For example, Attachment I – Transportation to the EA assumes a 66% mode share for self-drive and park at the Rancho Cucamonga station. Attachment I, Section 6.1.1.5, at 51. That assumption is optimistic given the timeline for related projects and the time required to induce a mode shift from a primarily auto-centric public to using the high-speed rail.

Furthermore, the City requests that the impacts to the three intersections projected to operate at an unacceptable level of service (namely Milliken Ave./Foothill Blvd, Milliken Ave./4th St., and Milliken Ave./1-10 WB ramps) be mitigated by requiring Brightline West to provide a fair share contribution to upgrade these intersections. This is appropriate given that these impacts would not occur absent the Project.

The EA states that Brightline West will coordinate with SBCTA, Caltrans, Rancho Cucamonga, and Hesperia to incorporate intersection improvements to lessen or avoid impacts under the 2045 Horizon Year to the extent feasible with signal timing optimization. EA Section 4.12.6.1, at 173. Signal timing optimization alone may not be sufficient. Modifications to the intersections, traffic signals and other measure(s), should also be required to fully mitigate any impacts from the Project on intersections.

Inaccurate Traffic Counts – The EA indicates in Section 4.12.3 that the “existing traffic volumes are based on traffic counts conducted in August 2020, except for the intersection of US-395/Joshua Street, which was conducted in October 2019.” This places the traffic counts in the middle of the COVID-19 pandemic and California “stay-at-home” orders which resulted in drastic reductions in traffic volumes across the nation as well as locally in the City. The EA does not acknowledge the effects of the stay-at-home orders and it appears no adjustments were made to the data to account for this difference based on other means of analyzing and incorporating historic traffic data into the analysis. Therefore, it is highly likely that the impacts of the project due to traffic are well-understated. The EA should be amended to account for the impacts of the COVID-19 pandemic on the traffic counts and incorporate historical traffic data into the traffic analysis as appropriate to enable accurate assessment of traffic impacts.

The Transportation Attachment to the EA also requires some correction. In Section 4.1, in the discussion of the City of Rancho Cucamonga Traffic Impact Analysis Guidelines, the Attachment incorrectly states the City’s General Plan only requires a Level of Service D for segments and intersection in the City not included in the City’s Congestion Management Plan. The General Plan requires a Level of Service D or better except at locations determined to be acceptable at a worse level of service. No such locations have been identified. Therefore, a level of service D or better is required at all locations in the City. Attachment I to the EA should be amended to correctly reflect the City’s level of service standards in the General Plan.

Section 4.3.1.2 Analysis Time Periods of Attachment I lists the Sunday peak time period from 1:00 – 3:00 p.m., but in Section 4.3.1.4 Existing and Forecast Traffic Volumes, the traffic counts for the Sunday “peak period” were conducted between 4:00 – 6:00 p.m. This inconsistency should be reconciled.

Amendment of Mitigation for Parking Impacts – The EA recognizes that the Project will have parking related impacts that require mitigation. As part of that mitigation, Brightline West is required to implement a parking demand management plan to address parking impacts at the Rancho Cucamonga Station as ridership and demand increases. EA Section 4.12.6.4, at 175. This parking management plan should be done in conjunction and in cooperation with adjacent public and private property owners, including the City, and to ensure the parking management plan is a districtwide solution with greater efficacy.

Brightline West is also required to work with the City to institute a neighborhood parking protection plan for existing or future neighborhoods near the station. This neighborhood parking protection plan should include additional parking enforcement officers and be expanded to apply to The Resort, 6th and 7th Street, Milliken Ave., Azusa Ct., Anaheim Place and any new residential subdivision streets.

In addition to mitigation already identified, Brightline West should also be required to develop agreements with existing users that have large off-site parking facilities such as Inland Empire Health Plan (“IEHP”) or the hotels on Milliken Ave. so that those large facilities’ often unused parking structures may be partially repurposed for greater districtwide parking.

As discussed above, the City strongly disagrees with the parking mitigation requiring Brightline West to expand existing parking facilities or construct additional parking facilities on City-owned property adjacent to the Rancho Cucamonga Station. Brightline West has represented that it will not take City-owned property for this purpose, and so we request that the EA be modified accordingly to omit this parking option.

Connecting Services – To address local transit impacts of the Project in Rancho Cucamonga, the EA states that Brightline West will coordinate with SBCTA and Omnitrans to provide sufficient bus service to serve Brightline West passengers at the Rancho Cucamonga Station on Sundays to monitor load factors and the number of Brightline West passengers on Omnitrans buses serving the Rancho Cucamonga Station and provide additional service during applicable time periods. In addition, the City suggests that Brightline West fund either more frequent service for Omnitrans’ West Valley Connector and/or help fund a local City circulator using the City’s offsite parking structures as it would better mitigate local transit impacts.

Missing Analysis of Intersection Modifications – In Section 2.4.5, the EA states, “The rail alignment will require the I-15 highway and interchange ramp modifications at Baseline Avenue.” This road is misnamed and is actually called “Base Line Road.” More substantively, there is no discussion in the rest of the EA as to the extent, detail or impact of the modification at this interchange. The EA should be updated to either add such discussion to Section 4.12 Transportation, or, if the reference was included in error, remove the language from Section 2.4.5.

D. Aesthetic and Design Quality

The EA identifies aesthetic and design quality impacts because the raised access road on the east side of I-15, elevated railway in the I-15 median, and new overpass structures would affect and partially block the views of the mountains and rolling terrain. EA Executive Summary, at xvii. In particular, the Rancho Cucamonga Station will be elevated on a structure and will detract from partial views of the San Gabriel Mountains from nearby office buildings. EA Section 4.7.5.2, at 115. In addition to the avoidance and minimization measures already identified, the City suggests that Brightline West be required to include a modest open space on the roof of the Rancho Cucamonga Station. This would create a space for users of the station to take their dogs, stretch their legs, and potentially provide some modest habitat for migrating birds. Placing this open space on top of the station would allow for views of the mountains that are being diminished from other

vantage points and thereby mitigate aesthetic impacts from the Project. Brightline West's original design included such an open space on top of the Rancho Cucamonga Station parking structure.

E. Air Quality

The EA states the Project will result in emissions of criteria pollutants and GHGs and identifies several mitigation measures to address such impacts. Mitigation Measure AQ-1 is focused on controlling fugitive dust during construction to meet Mojave Desert Air Quality Management District Rule 403. One element of Mitigation Measure AQ-1 to prevent Project-related track-out onto paved surfaces to “[r]educe nonessential earth-moving activity under high wind conditions.” This measure may not fully mitigate dust originating from disturbed areas. EA Section 4.1.6, at 36. The City recommends that Mitigation Measure AQ-2 be improved to ensure the same regulatory requirements are applicable to dust mitigation according to the South Coast Air Quality Management District requirements and local ordinances.

F. Noise and Vibration

The EA identifies nine single-family homes along the northbound side of the proposed alignment between Arrow Road and Base Line Road that are projected to have moderate noise impacts. EA Section 4.2.5.3, at 49. Although the EA indicates the impacts are not significant enough to require mitigation for noise or vibration, the City has been contacted by these residents who are understandably concerned about the potential impacts on their quality of life and property values. In addition to the mitigation proposed in the EA, the City requests that the FRA consider requiring Brightline West to pay for upgraded windows and insulation in these homes to offset any potential, even below the level of significance, that vibration or noise may have to these residences.

In Section 4.2.5.2, the EA assumes minimal impacts due to vibration because the work will be at least 100 feet from existing development due to the location in the median of I-15. However, Final EA should acknowledge that the alignment of the Project corridor south of Church Street will move to the west and closer to existing development. This realignment should also be incorporated into the FRA's final determination during final design. EA Section 4.2.5.2, at 48.

G. Water Quality

In Section 4.13 Water Quality, the EA imposes several mitigation measures to address the Project impacts to water quality.

Mitigation Measure WQ-1 states, “BMPs will be selected to achieve maximum sediment removal and represent the best available technology that is economically achievable.” EA Section 4.13.6.1, at 181. The EA should be amended to clearly state which regulatory authority will determine whether BMPs represent the economically achievable best available technology.

Mitigation Measure WQ-4 identifies a list of agencies that are to be contacted in case of a spill during construction. EA Section 4.13.6.1, at 181. This list should be amended to include the Rancho Cucamonga Fire Protection District (“RCFPD”). RCFPD is the emergency response agency for hazardous materials in the City of Rancho Cucamonga.

Mitigation Measure WQ-7 requires BMPs to be sized and designed to “not allow untreated stormwater runoff to reach to Mojave River, the California Aqueduct or any washes along the *alignment*.” EA Section 4.13.6.2, at 182. This mitigation measure should be expanded to specifically reference the station sites as well as the longitudinal rail alignment.

H. Additional Comments

- Section 4.3 Wetland and Stream Areas does not mention that the Project crosses the Day Creek channel and does not discuss any potential impacts due to any such crossing. Attachment D, Section 5.1.1.1 provides that “The proposed bridges over Day Creek and East Etiwanda Creek would fully span the channels of those features, that is, bridge piers would not be placed in the channels. No construction work is proposed in the channels of Day Creek and East Etiwanda Creek. Oro Grande Wash is culverted at the proposed project crossing, so no construction work is expected at this crossing. No construction impacts are expected for these crossings.” The City recommends this detail be included in the EA to make it clear that the Day Creek crossing was analyzed.
- In Section 4.7.6 Avoidance, Minimization and Mitigation Measures, under the subsection Construction the EA states, “Disturbed areas within Caltrans right-of-way will be regraded to soften their contours and will be replanted as directed by Caltrans and within six months of the completion of construction.” EA Section 4.7.6, at 116. This requirement should be expanded to require areas outside of the Caltrans’ right-of-way, such as City-owned property or privately owned property, to be regraded and replanted where disturbed.
- In Section 4.8.5.2, the EA states, “Reconstruction and I-15 freeway and interchange ramp modifications will also occur within the Caltrans right-of-way within the City of Rancho Cucamonga at SR-210, Beech Avenue, Duncan Canyon Road, and Glen Helen Parkway.” EA Section 4.8.5.2, at 123. However, Beech Avenue, Duncan Canyon Road, and Glen Helen Parkway interchanges are not in the City of Rancho Cucamonga. The EA should be updated to reflect the correct locations of these interchanges.
- In Section 4.10.5.2, the EA states, “Project construction may require demolition and/or removal of buildings near the Rancho Cucamonga station . . .” EA Section 4.10.5.2, at 134. The City is unaware of demolition required near the station and thus cannot fully comment on whether there are additional impacts from this statement. The EA should be updated to include more detail regarding this anticipated demolition, if any. Further, reference is made to a property with hazardous materials located at 8886 Vincent Avenue in Rancho Cucamonga. The City is unaware of a property with this address. The address should be confirmed and the EA updated as appropriate.

Once again, the proposed high-speed rail station will convert the City’s existing Metrolink Station into an important interstate and regional transportation hub within the City. The City has been working cooperatively with Brightline West for several years to reach this point and we are enthusiastically supportive of the overall project and looking forward to it potentially commencing construction in 2023. It will have huge benefits for the City and the entire region. In that light we offer the aforementioned comments, many of which are technical in nature, to ensure the best

Federal Railroad Administration
United States Department of Transportation
November 28, 2022
Page 8

possible project for all parties. We look forward to working with Brightline West and the Federal Railroad Administration to facilitate the successful development of the Project.

Please do not hesitate to contact me if you have any questions. City staff is available to meet with you to discuss our comments in more detail.

Very truly yours,

A handwritten signature in black ink, appearing to read "J. Gillison". The signature is fluid and cursive, with a long horizontal stroke at the beginning and a large loop at the end.

John Gillison
City Manager
City of Rancho Cucamonga

cc: Rancho Cucamonga City Council



THE METROPOLITAN WATER DISTRICT
OF SOUTHERN CALIFORNIA

Office of the General Manager

November 21, 2022

ELECTRONIC SUBMITTAL

Matthew Mielke, Environmental Protection Specialist
Environmental Review Division
Federal Railroad Administration
1200 New Jersey Avenue, SE
West Building, Mail Stop 20
Washington, DC 20590
matthew.mielke@dot.gov

Dear Mr. Matthew Mielke:

Environmental Assessment for the Brightline West Cajon Pass High Speed Rail Project

The Metropolitan Water District of Southern California (Metropolitan) reviewed the Environmental Assessment (EA) for the Brightline West Cajon Pass High Speed Rail Project (Project). The public comment period for the EA begun on October 28, 2022 and ends November 28, 2022.

The United States Department of Transportation's (USDOT) Federal Railroad Administration (FRA) prepared an EA in accordance with the National Environmental Policy Act (NEPA) to evaluate the potential environmental impacts from the Project. The Project is a 49-mile train system capable of reaching a top speed of approximately 140 miles per hour (mph) between Victor Valley and Rancho Cucamonga, California. The Project includes two new railway stations, one in Hesperia and one in Rancho Cucamonga. The connecting station in Victor Valley was approved as part of a separate project and evaluated under a separate NEPA document. The Project sponsor is DesertXpress Enterprises, LLC (dba "Brightline West").

Metropolitan owns and operates facilities within and adjacent to the proposed project limits. As shown on the attached map, Metropolitan's Rialto Pipeline, an approximately 96-inch inside-diameter pipeline, crosses Interstate 15 (I-15) south of Duncan Canyon Road and north of Beech Avenue within Metropolitan fee-owned property in the City of Fontana. The proposed Project would be located in the median of I-15 where it would cross Metropolitan fee-owned property and the Rialto Pipeline at approximately station 3638+00. Metropolitan is concerned with potential impacts to this facility and rights-of-way that may result from implementation of the proposed Project.

Metropolitan must be allowed to maintain its rights-of-way and access to its facilities and properties at all times, in order to repair and maintain the current condition of those facilities. In order to avoid potential conflicts with Metropolitan's rights-of-way, we require that any design

Matthew Mielke
Page 2
November 21, 2022

plans for any activity in the area of Metropolitan's pipelines or facilities be submitted for our review and written approval. Metropolitan will not permit procedures that could subject the pipes to excessive vehicle, impact or vibratory loads. Any future design plans associated with this Project should be submitted to the attention of Metropolitan's Substructures Team. Metropolitan's Substructures Team reviewed a memorandum dated July 18, 2022 from HNTB Corporation, which it received from Brightline West and which presents the results of stress and settlement analysis on the Rialto Pipeline due to load impacts that would occur from the proposed Project. Metropolitan's Substructures Team has the following comments on HNTB Corporation's memorandum:

1. The proposed single-track high-speed rail crossing over our Rialto Pipeline and fee-property right-of-way as described in the memorandum, is conceptually acceptable to Metropolitan. However, the developer must submit plans and specifications for Metropolitan's review and written approval at least 60 days prior to beginning construction. Additional supporting calculations, including a 3D analysis, will be required to show that the proposed rail crossing will not adversely affect Metropolitan's Rialto Pipeline.
2. Metropolitan has concerns that the specified loading standard (Cooper E-70) does not fully encompass the high-speed rail's impact to our facilities. Please provide the following:
 - a. Maximum free surface horizontal/vertical displacements at the crossing.
 - b. Profile of free surface horizontal/vertical displacements along the pipeline alignment at the crossing, following Metropolitan Geotechnical Guidelines.
 - c. Shear wave velocity in the foundation.
 - d. Dominant frequency (period) of the ground vibration
 - e. Dominant wave length.
 - f. Dynamic load factor for the HST.
3. Provide at least three experimental/case study historical data from analysis of similar high speed rail crossings with three-component ground acceleration at multiple distances to 100 feet perpendicular from the railroad. These examples should include soil properties, and have similar rail properties (loading and maximum speed) as the proposed railway.
4. Provide a site-specific geotechnical report which should include the shear wave velocity profile and shear strength of the soil.
5. Provide a 3D analysis of Metropolitan's pipeline. Per Metropolitan's Geotechnical Guidelines, the three-dimensional alignment of the pipeline should be considered in calculating the vertical and lateral deformations and in computing the fiber, hoops, and

Matthew Mielke
Page 3
November 21, 2022

shear stresses along the pipeline. The 3D analysis should be performed separately for both the three axles of the locomotive and the two axles of the passenger cars and see which one provides the maximum displacements and stresses.

6. We request that a stipulation is included in the plans and/or specifications to notify Metropolitan at least two working days prior to starting any work on the subject property. We recommend that Jesse Franco of our Water System Operations Team, telephone (818) 468-5188, be the primary contact.

Approval of the Project is contingent on Metropolitan's approval of design plans for portions of the proposed Project that could impact its facilities.

Detailed prints of drawings of Metropolitan's pipelines and rights-of-way may be obtained by contacting Metropolitan's Substructures Team at EngineeringSubstructures@mwdh2o.com. To assist the Brightline West (Project sponsor) and the FRA (NEPA Lead Agency) in preparing plans that are compatible with Metropolitan's facilities and rights-of-way, enclosed is a copy of the "Guidelines for Developments in the Area of Facilities, Fee Properties, and/or Easement of The Metropolitan Water District of Southern California." Please note that Metropolitan's facilities and rights-of-way must be fully shown and identified as Metropolitan's on all designs or plans submitted.

Additionally, in January 2017, Metropolitan's Board of Directors certified a Final Programmatic Environmental Impact Report for the Prestressed Concrete Cylinder Pipe Rehabilitation Program (PCCP). The PCCP Rehabilitation Program is a comprehensive effort to manage Metropolitan's PCCP feeders, which includes the Rialto Pipeline. The scope of the program includes: aggressively inspecting and monitoring the condition of all PCCP lines; installing cathodic protection as a proactive and cost-effective measure to prevent corrosion; repairing individual distressed PCCP segments, as necessary; and rehabilitating five priority PCCP feeders in a planned, systematic fashion. Inspection and repairs to the Rialto Pipeline under the PCCP Program have not started and may coincide with construction of the proposed Project.

Metropolitan requests that the FRA avoid any potential impacts that may occur to the Rialto Pipeline due to implementation of the proposed Project or where applicable and propose mitigation measures to offset any potential impacts. Also, FRA will need to consider Metropolitan's Rialto Pipeline in its project planning.

Appropriate property rights must be obtained from Metropolitan for any project activities within Metropolitan's property, such as the granting of a road easement or license. The granting of property rights may be subject to Metropolitan's Board of Director's approval. No work may be done including potholing or any studies within Metropolitan's property prior to the execution of an appropriate agreement. Please contact Metropolitan's Real Property Group regarding the

Matthew Mielke
Page 4
November 21, 2022

process for obtaining access or property rights at RealEstateServices@mwdh2o.com. Metropolitan recommends that the EA include reference to Metropolitan's property and granting of an agreement.

We appreciate the opportunity to provide input to your planning process. If we can be of further assistance, please contact Alfredo Aguirre at (213) 217-6730 or at aaguirre@mwdh2o.com.

Very truly yours,

Sean Carlson
Team Manager, Environmental Planning Section

AA: lim:rdl

S:\External Reviews\External Reviews\Comment Letters\2022-Comment Letters\USDT_Cajon Pass High-Speed Rail Project





Enclosures:

- 1) Location Map of Metropolitan's Rialto Pipeline within the Project Limits
- 2) Guidelines for Developments in the Area of Facilities, Fee Properties, and/or Easements of The Metropolitan Water District of Southern California
- 3) HNTB Corporation's Memorandum

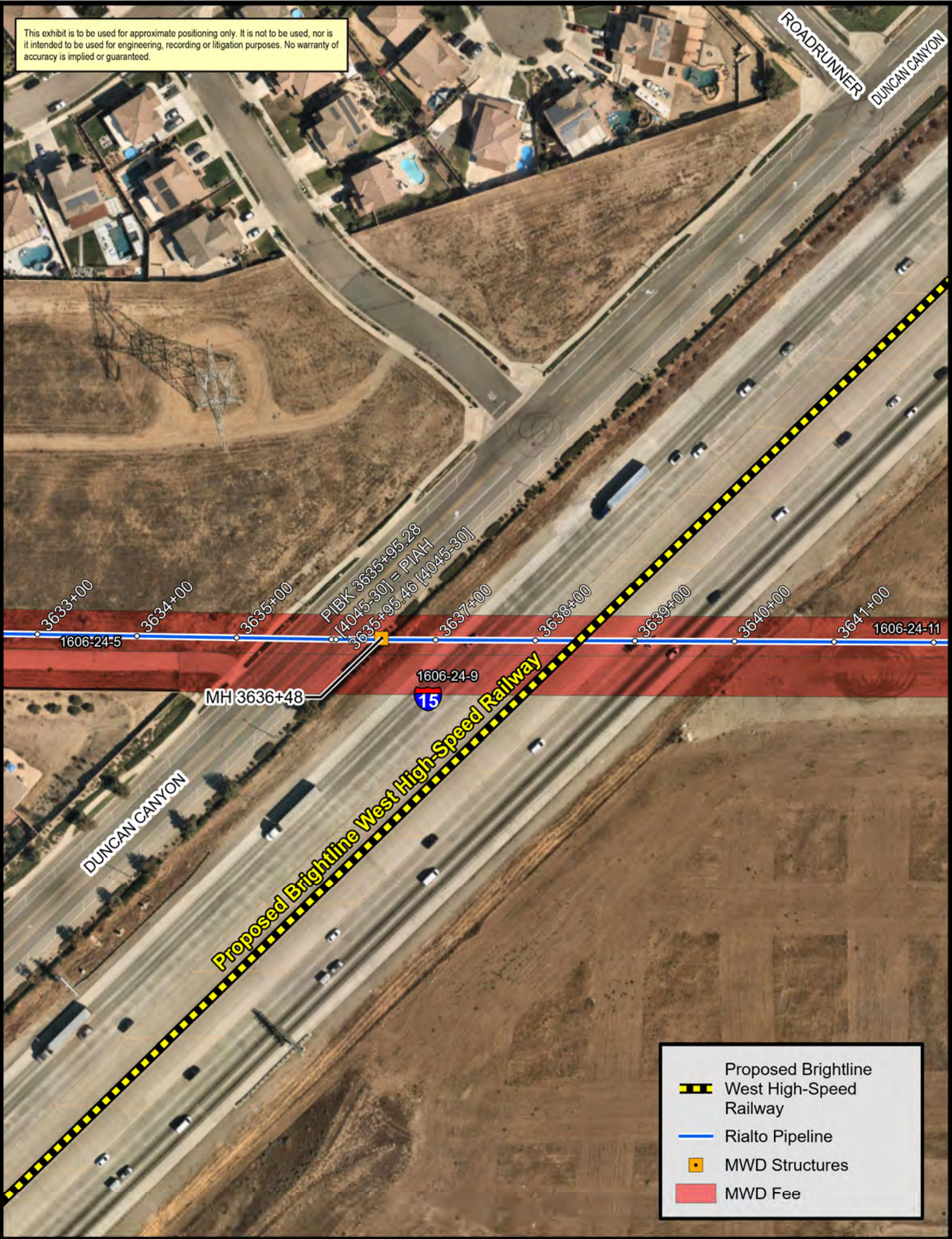
This exhibit is to be used for approximate positioning only. It is not to be used, nor is it intended to be used for engineering, recording or litigation purposes. No warranty of accuracy is implied or guaranteed.

\\usnetapp01\Infrastructure_Reliability_Section\Infrastructure_Unit\Geodetics_and_Mapping_Team_1\Projects\Rialto_Pipeline\GIS\Rialto_Pipeline_GIS\Rialto_Pipeline_GIS\Map_Series\Map_Series_11162022.aprx [Printed 11/16/2022], Prepared by: Enrique Chen (GMT1), Requestor: Alfredo Aguirre, Job#: GIS22-11-27



-  Proposed Brightline West High-Speed Railway
-  Rialto Pipeline
-  MWD Structures
-  MWD Fee

**Guidelines for
Improvements and Construction Projects Proposed
in the Area of
Metropolitan's Facilities and Rights-of-Way**

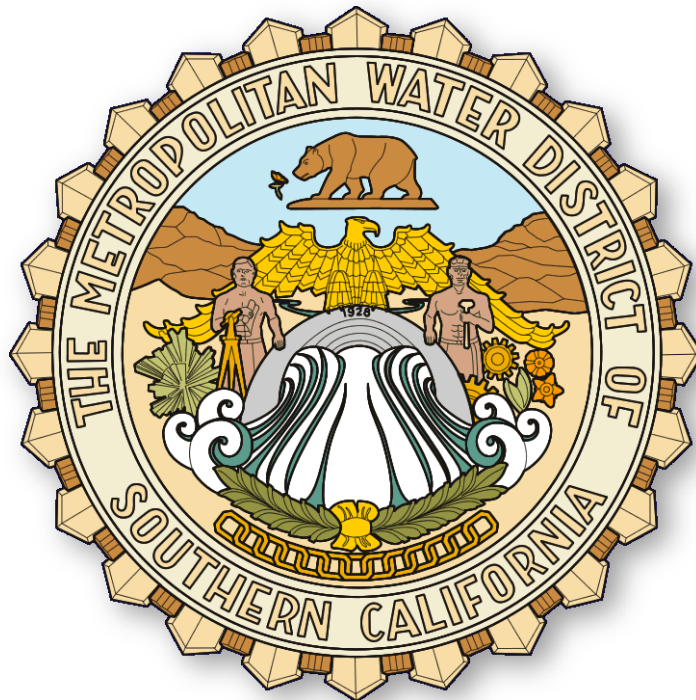

July 2018

Prepared By:
The Metropolitan Water District of Southern California
Substructures Team, Engineering Services
700 North Alameda Street
Los Angeles, California 90012

Copyright © 2018 by The Metropolitan Water District of Southern California.

Additional Copies: To obtain a copy of this document, please contact the Engineering Services Group, Substructures Team.

Disclaimer

Metropolitan assumes no responsibility for the accuracy of the substructure information herein provided. The user assumes responsibility for verifying substructure locations before excavating and assumes all liability for damage to Metropolitan's facilities as a result of such excavation. Additionally, the user is cautioned to conduct surveys and other field investigations as deemed prudent, to assure that project plans are correct. The appropriate representative from Metropolitan must be contacted at least two working days, before any work activity in proximity to Metropolitan's facilities.

It generally takes 30 days to review project plans and provide written responses. Metropolitan reserves the right to modify requirements based on case-specific issues and regulatory developments.

PUBLICATION HISTORY:

Initial Release

July 2018

Table of Contents

1.0	GENERAL INFORMATION	1
1.1	Introduction	1
1.2	Submittal and Review of Project Plans/Utilities and Maps	1
1.3	Identification of Metropolitan’s Facilities and Rights-of-Way	3
2.0	General Requirements	3
2.1	Vehicular Access	3
2.2	Fences	3
2.3	Driveways and Ramps	3
2.4	Walks, Bike Paths, and Trails	3
2.5	Clear Zones	4
2.6	Slopes	4
2.7	Structures	4
2.8	Protection of Metropolitan Facilities	4
2.9	Potholing of Metropolitan Pipelines	4
2.10	Jacked Casings or Tunnels	4
3.0	Landscaping	5
3.1	Plans	5
3.2	Drought-Tolerant Native and California Friendly Plants	5
3.3	Trees	5
3.4	Other Vegetation	6
3.5	Irrigation	6
3.6	Metropolitan Vehicular Access	6
4.0	General Utilities	6
4.1	Utility Structures	6
4.2	Utility Crossings	6
4.3	Longitudinal Utilities	7
4.4	Underground Electrical Lines	7
4.5	Fiber Optic Lines	7
4.6	Overhead Electrical and Telephone Lines	7
4.7	Sewage Disposal Systems	7
4.8	Underground Tanks	8
5.0	Specific Utilities: Non-Potable Utility Pipelines	8
6.0	Cathodic Protection/Electrolysis Test Stations	8
6.1	Metropolitan Cathodic Protection	8
6.2	Review of Cathodic Protection Systems	8
7.0	Drainage	9
7.1	Drainage Changes Affecting Metropolitan Rights-of-Way	9
7.2	Metropolitan’s Blowoff and Pumpwell Structures	9
8.0	Grading and Settlement	9

Table of Contents

8.1 Changes in Cover over Metropolitan Pipelines..... 9

8.2 Settlement 9

9.0 Construction Equipment10

9.1 Review of Proposed Equipment.....10

9.2 Equipment Restrictions10

9.3 Vibratory Compaction Equipment.....10

9.4 Equipment Descriptions10

10.0 Excavations Close to Metropolitan Facilities11

10.1 Shoring Design Submittal.....11

10.2 Shoring Design Requirements11

11.0 Support of Metropolitan Facilities.....11

11.1 Support Design Submittal11

11.2 Support Design Requirements11

12.0 Backfill.....12

12.1 Metropolitan Pipeline Not Supported.....12

12.2 Metropolitan Pipeline Partially Exposed12

12.3 Metropolitan Cut and Cover Conduit on Colorado River Aqueduct (CRA).....12

13.0 Piles13

13.1 Impacts on Metropolitan Pipelines13

13.2 Permanent Cast-in-place Piles.....13

14.0 Protective Slabs for Road Crossings Over Metropolitan Pipelines13

15.0 Blasting13

16.0 Metropolitan Plan Review Costs, Construction Costs and Billing14

16.1 Plan Review Costs.....14

16.2 Cost of Modification of Facilities Performed by Metropolitan14

16.3 Final Billing14

17.0 Street Vacations and Reservation of Easements for Metropolitan14

18.0 Metropolitan Land Use Guidelines.....14

19.0 Compliance with Environmental Laws and Regulations.....15

20.0 Paramount Rights / Metropolitan’s Rights within Existing Rights-of-Way17

21.0 Disclaimer and Information Accuracy17

Table of Contents

Table 1: General Guidelines for Pipeline Separation between Metropolitan’s Pipeline¹ and Sanitary Sewer² or Hazardous Fluid Pipeline³ 18

Table 2: General Guidelines for Pipeline “Separation between Metropolitan’s Pipeline¹ and Storm Drain and/or Recycled Water² 19

Table 3: General Guidelines for Pipeline “Separation¹ between Metropolitan’s Pipeline and Recycled Water^{2,4} Irrigationsm,20

Figure 1: AASHTO H-20 Loading21

Figure 2: Drawing SK-122

This page is intentionally blank.

1.0 GENERAL INFORMATION

Note: Underground Service Alert at 811 must be notified at least two working days before excavating in proximity to Metropolitan's facilities.

1.1 Introduction

These guidelines provide minimum design and construction requirements for any utilities, facilities, developments, and improvements, or any other projects or activities, proposed in or near Metropolitan Water District of Southern California (Metropolitan) facilities and rights-of-way. Additional conditions and stipulations may also be required depending on project and site specific conditions. Any adverse impacts to Metropolitan's conveyance system, as determined by Metropolitan, will need to be mitigated to its satisfaction.

All improvements and activities must be designed so as to allow for removal or relocation at builder or developer expense, as set forth in the paramount rights provisions of Section 20.0. Metropolitan shall not be responsible for repair or replacement of improvements, landscaping or vegetation in the event Metropolitan exercises its paramount rights powers.

1.2 Submittal and Review of Project Plans/Utilities and Maps

Metropolitan requires project plans/utilities be submitted for all proposed activities that may impact Metropolitan's facilities or rights-of-way. Project plans shall include copies of all pertinent utilities, sewer line, storm drain, street improvement, grading, site development, landscaping, irrigation and other plans, all tract and parcel maps, and all necessary state and federal environmental documentation. Metropolitan will review the project plans and provide written approval, as it pertains to Metropolitan's facilities and rights-of-way. Written approval from Metropolitan must be obtained, prior to the start of any activity or construction in the area of Metropolitan's facilities or rights-of-way. Once complete project plans and supporting documents are submitted to Metropolitan, it generally takes 30 days to review and to prepare a detailed written response. Complex engineering plans that have the potential for significant impacts on Metropolitan's facilities or rights-of-way may require a longer review time.

Project plans, maps, or any other information should be submitted to Metropolitan's Substructures Team at the following mailing address:

**Attn: Substructures Team
The Metropolitan Water District of Southern California
700 North Alameda St.
Los Angeles, CA 90012**

**General Mailing Address: P.O. Box 54153
Los Angeles, CA 90054-0153**

Email: EngineeringSubstructures@mwdh2o.com

For additional information, or to request prints of detailed drawings for Metropolitan's facilities and rights-of-way, please contact Metropolitan's Substructures Team at 213-217-7663 or EngineeringSubstructures@mwdh2o.com.

1.3 Identification of Metropolitan's Facilities and Rights-of-Way

Metropolitan's facilities and rights-of-way must be fully shown and identified as Metropolitan's, with official recording data, on the following:

- A. All applicable plans
- B. All applicable tract and parcel maps

Metropolitan's rights-of-ways and existing survey monuments must be tied dimensionally to the tract or parcel boundaries. Metropolitan's Records of Survey must be referenced on the tract and parcel maps with the appropriate Book and Page.

2.0 General Requirements

2.1 Vehicular Access

Metropolitan must have vehicular access along its rights-of-way at all times for routine inspection, patrolling, operations, and maintenance of its facilities and construction activities. All proposed improvements and activities must be designed so as to accommodate such vehicular access.

2.2 Fences

Fences installed across Metropolitan's rights-of-way must include a 16-foot-wide gate to accommodate vehicular access by Metropolitan. Additionally, gates may be required at other specified locations to prevent unauthorized entry into Metropolitan's rights-of-way.

All gates must accommodate a Metropolitan lock or Knox-Box with override switch to allow Metropolitan unrestricted access. There should be a minimum 20-foot setback for gates from the street at the driveway approach. The setback is necessary to allow Metropolitan vehicles to safely pull off the road prior to opening the gate.

2.3 Driveways and Ramps

Construction of 16-foot-wide commercial-type driveway approaches is required on both sides of all streets that cross Metropolitan's rights-of-way. Access ramps, if necessary, must be a minimum of 16 feet wide.

There should be a minimum 20-foot setback for gates from the street at the driveway approach. Grades of ramps and access roads must not exceed 10 percent; if the slope of an access ramp or road must exceed 10 percent due to topography, then the ramp or road must be paved.

2.4 Walks, Bike Paths, and Trails

All walkways, bike paths, and trails along Metropolitan's rights-of-way must be a minimum 12-foot wide and have a 50-foot or greater radius on all horizontal curves if also used as Metropolitan's access roads. Metropolitan's access routes, including all walks and drainage facilities crossing the access routes, must be constructed to American Association of State Highway and Transportation Officials (AASHTO) H-20 loading standards (see Figure 1). Additional requirements will be placed on equestrian trails to protect the water quality of Metropolitan's pipelines and facilities.

2.5 Clear Zones

A 20-foot-wide clear zone is required to be maintained around Metropolitan's manholes and other above-ground facilities to accommodate vehicular access and maintenance. The clear zone should slope away from Metropolitan's facilities on a grade not to exceed 2 percent.

2.6 Slopes

Cut or fill slopes proposed within Metropolitan's rights-of-way must not exceed 10 percent. The proposed grade must not worsen the existing condition. This restriction is required to facilitate Metropolitan use of construction and maintenance equipment and allow uninhibited access to above-ground and below-ground facilities.

2.7 Structures

Construction of structures of any type is not allowed within the limits of Metropolitan's rights-of-way to avoid interference with the operation and maintenance of Metropolitan's facilities and possible construction of future facilities.

Footings and roof eaves of any proposed buildings adjacent to Metropolitan's rights-of-way must meet the following criteria:

- A. Footings and roof eaves must not encroach onto Metropolitan's rights-of-way.
- B. Footings must not impose any additional loading on Metropolitan's facilities.
- C. Roof eaves must not overhang onto Metropolitan's rights-of-way.

Detailed plans of footings and roof eaves adjacent to Metropolitan's rights-of-way must be submitted for Metropolitan's review and written approval, as pertains to Metropolitan's facilities.

2.8 Protection of Metropolitan Facilities

Metropolitan facilities within its rights-of-way, including pipelines, structures, manholes, survey monuments, etc., must be protected from damage by the project proponent or property owner, at no expense to Metropolitan. The exact location, description and method of protection must be shown on the project plans.

2.9 Potholing of Metropolitan Pipelines

Metropolitan's pipelines must be potholed in advance, if the vertical clearance between a proposed utility and Metropolitan's pipeline is indicated to be 4 feet or less. A Metropolitan representative must be present during the potholing operation and will assist in locating the pipeline. Notice is required, a minimum of three working days, prior to any potholing activity.

2.10 Jacked Casings or Tunnels

A. General Requirements

Utility crossings installed by jacking, or in a jacked casing or tunnel under/over a Metropolitan pipeline, must have at least 3 feet of vertical clearance between the outside diameter of the pipelines and the jacked pipe, casing, or tunnel. The actual

cover over Metropolitan's pipeline shall be determined by potholing, under Metropolitan's supervision.

Utilities installed in a jacked casing or tunnel must have the annular space between the utility and the jacked casing or tunnel filled with grout. Provisions must be made for grouting any voids around the exterior of the jacked pipe, casing, or tunnel.

B. Jacking or Tunneling Procedures

Detailed jacking, tunneling, or directional boring procedures must be submitted to Metropolitan for review and approval. The procedures must cover all aspects of operation, including, but not limited to, dewatering, ground control, alignment control, and grouting pressure. The submittal must also include procedures to be used to control sloughing, running, or wet ground, if encountered. A minimum 10-foot clearance must be maintained between the face of the tunneling or receiving pits and outside edges of Metropolitan's facility.

C. Shoring

Detailed drawings of shoring for jacking or receiving pits must be submitted to Metropolitan for review and written-approval. (See Section 10 for shoring requirements).

D. Temporary Support

Temporary support of Metropolitan's pipelines may be required when a utility crosses under a Metropolitan pipeline and is installed by means of an open trench. Plans for temporary support must be reviewed and approved in writing by Metropolitan. (See Section 11, Supports of Metropolitan Facilities).

3.0 Landscaping

3.1 Plans

All landscape plans must show the location and limits of Metropolitan's right-of-way and the location and size of Metropolitan's pipeline and related facilities therein. All landscaping and vegetation shall be subject to removal without notice, as may be required by Metropolitan for ongoing maintenance, access, repair, and construction activities. Metropolitan will not be financially responsible for the removal of any landscaping and vegetation.

3.2 Drought-Tolerant Native and California Friendly Plants

Metropolitan recommends use of drought-tolerant native and California Friendly® plants (excluding sensitive plants) on proposed projects. For more information regarding California Friendly® plants refer to www.bewaterwise.com.

3.3 Trees

Trees are generally prohibited within Metropolitan's rights-of-way as they restrict Metropolitan's ability to operate, maintain and/or install new pipeline(s) located within these rights-of-way. Metropolitan will not be financially responsible for the removal and replacement of any existing trees should they interfere with access and any current or future Metropolitan project located within the right-of-way.

3.4 Other Vegetation

Shrubs, bushes, vines, and groundcover are generally allowed within Metropolitan's rights-of-way. Larger shrubs are not allowed on Metropolitan fee properties; however, they may be allowed within its easements if planted no closer than 15 feet from the outside edges of existing or future Metropolitan facilities. Only groundcover is allowed to be planted directly over Metropolitan pipeline, turf blocks or similar is recommended to accommodate our utility vehicle access. Metropolitan will not be financially responsible for the removal and replacement of the vegetation should it interfere with access and any current or future Metropolitan project.

3.5 Irrigation

Irrigation systems are acceptable within Metropolitan's rights-of-way, provided valves and controllers are located near the edges of the right-of-way and do not interfere with Metropolitan vehicular access. A shutoff valve should also be located along the edge of the right-of-way that will allow the shutdown of the system within the right-of-way should Metropolitan need to do any excavation. No pooling or saturation of water above Metropolitan's pipeline and right-of-way is allowed. Additional restrictions apply to non-potable water such as Recycled Water and are covered on Table 3 of Page 20.

3.6 Metropolitan Vehicular Access

Landscape plans must show Metropolitan vehicular access to Metropolitan's facilities and rights-of-way and must be maintained by the property owner or manager or homeowners association at all times. Walkways, bike paths, and trails within Metropolitan's rights-of-way may be used as Metropolitan access routes. (See Section 2.4, Walks, Bike Paths, and Trails).

4.0 General Utilities

Note: For non-potable piping like sewer, hazardous fluid, storm drain, disinfected tertiary recycled water and recycled water irrigation see Table 1 through Table 3.

4.1 Utility Structures

Permanent utility structures (e.g., manholes, power poles, pull boxes, electrical vaults, etc.) are not allowed within Metropolitan's rights-of-way. Metropolitan requests that all permanent utility structures within public streets be placed as far from its pipelines and facilities as practical, but not closer than 5 feet from the outside edges of Metropolitan facilities.

Note: Non-potable utility pipelines are an exception to the 5-foot minimum clearance. Non-potable utility pipelines should have 10 feet of separation.

4.2 Utility Crossings

Metropolitan requests a minimum of 1 foot of vertical clearance between Metropolitan's pipeline and any utility crossing the pipeline. Utility lines crossing Metropolitan's pipelines must be as perpendicular to the pipeline as possible. Cross-section drawings, showing proposed locations and elevations of utility lines and locations of Metropolitan's pipelines and limits of rights-of-way, must be submitted with utility plans, for all

crossings. Metropolitan's pipeline must be potholed under Metropolitan's supervision at the crossings (See Section 2.9).

4.3 Longitudinal Utilities

Installation of longitudinal utilities is generally not allowed along Metropolitan's rights-of-way. Within public streets, Metropolitan requests that all utilities parallel to Metropolitan's pipelines and appurtenant structures (facilities) be located as far from the facilities as possible, with a minimum clearance of 5 feet from the outside edges of the pipeline.

Note: Non-potable utility pipelines are an exception to the 5-foot minimum clearance. Non-potable utility pipelines should have 10 feet of separation (for more information See Table 1 on Page 18).

4.4 Underground Electrical Lines

Underground electrical conduits (110 volts or greater) which cross a Metropolitan's pipeline must have a minimum of 1 foot of vertical clearance between Metropolitan's pipeline and the electrical lines. Longitudinal electrical lines, including pull boxes and vaults, in public streets should have a minimum separation of 5 feet from the edge of a Metropolitan pipeline or structures.

4.5 Fiber Optic Lines

Fiber optic lines installed by directional boring require a minimum of 3 feet of vertical clearance when boring is over Metropolitan's pipelines and a minimum of 5 feet of vertical clearance when boring is under Metropolitan's pipelines. Longitudinal fiber optic lines, including pull boxes, in public streets should have a minimum separation of 5 feet from the edge of a Metropolitan pipelines or structures. Potholing must be performed, under Metropolitan's supervision, to verify the vertical clearances are maintained.

4.6 Overhead Electrical and Telephone Lines

Overhead electrical and telephone lines, where they cross Metropolitan's rights-of-way, must have a minimum 35 feet of clearance, as measured from the ground to the lowest point of the overhead line. Overhead electrical lines poles must be located at least 30 feet laterally from the edges of Metropolitan's facilities or outside Metropolitan's right-of-way, whichever is greater.

Longitudinal overhead electrical and or telephone lines in public streets should have a minimum separation of 10 feet from the edge of a Metropolitan pipelines or structures where possible.

4.7 Sewage Disposal Systems

Sewage disposal systems, including leach lines and septic tanks, must be a minimum of 100 feet from the outside limits of Metropolitan's rights-of-way or the edge of its facilities, whichever is greater. If soil conditions are poor, or other adverse site-specific conditions exist, a minimum distance of 150 feet is required. They must also comply with local and state health code requirements as they relate to sewage disposal systems in proximity to major drinking water supply pipelines.

4.8 Underground Tanks

Underground tanks containing hazardous materials must be a minimum of 100 feet from the outside limits of Metropolitan's rights-of-way or edge of its facilities, whichever is greater. In addition, groundwater flow should be considered with the placement of underground tanks down-gradient of Metropolitan's facilities.

5.0 Specific Utilities: Non-Potable Utility Pipelines

In addition to Metropolitan's general requirements, installation of non-potable utility pipelines (e.g., storm drains, sewers, and hazardous fluids pipelines) in Metropolitan's rights-of-way and public street rights-of-way must also conform to the State Water Resources Control Board's Division of Drinking Water (DDW) regulation (Waterworks Standards) and guidance for separation of water mains and non-potable pipelines and to applicable local county health code requirements. Written approval is required from DDW for the implementation of alternatives to the Waterworks Standards and, effective December 14, 2017, requests for alternatives to the Waterworks Standards must include information consistent with: DDW's [Waterworks Standards Main Separation Alternative Request Checklist](#).

In addition to the following general guidelines, further review of the proposed project must be evaluated by Metropolitan and requirements may vary based on site specific conditions.

- A. Sanitary Sewer and Hazardous Fluids (General Guideline See Table 1 on Page 18)
- B. Storm Drain and Recycled Water (General Guideline See Table 2 on Page 19)
- C. Irrigation with Recycled Water (General Guideline See Table 3 on Page 20)
- D. Metropolitan generally does not allow Irrigation with recycled water to be applied directly above its treated water pipelines
- E. Metropolitan requests copies of project correspondence with regulating agencies (e.g., Regional Water Quality Control Board, DDW); regarding the application of recycled water for all projects located on Metropolitan's rights-of-way

6.0 Cathodic Protection/Electrolysis Test Stations

6.1 Metropolitan Cathodic Protection

Metropolitan's existing cathodic protection facilities in the vicinity of any proposed work must be identified prior to any grading or excavation. The exact location, description, and type of protection must be shown on all project plans. Please contact Metropolitan for the location of its cathodic protection stations.

6.2 Review of Cathodic Protection Systems

Metropolitan must review any proposed installation of impressed-current cathodic protection systems on pipelines crossing or paralleling Metropolitan's pipelines to determine any potential conflicts with Metropolitan's existing cathodic protection system.

7.0 Drainage

7.1 Drainage Changes Affecting Metropolitan Rights-of-Way

Changes to existing drainage that could affect Metropolitan's rights-of-way require Metropolitan's approval. The project proponent must provide acceptable solutions to ensure Metropolitan's rights-of-way are not negatively affected by changes in the drainage conditions. Plans showing the changes, with a copy of a supporting hydrology report and hydraulic calculations, must be submitted to Metropolitan for review and approval. Long term maintenance of any proposed drainage facilities must be the responsibility of the project proponent, City, County, homeowner's association, etc., with a clear understanding of where this responsibility lies. If drainage must be discharged across Metropolitan's rights-of-way, it must be carried across by closed conduit or lined open channel and must be shown on the plans.

7.2 Metropolitan's Blowoff and Pumpwell Structures

Any changes to the existing local watercourse systems will need to be designed to accommodate Metropolitan's blowoff and pumpwell structures, which periodically convey discharged water from Metropolitan's blowoff and pumping well structures during pipeline dewatering. The project proponents' plans should include details of how these discharges are accommodated within the proposed development and must be submitted to Metropolitan for review and approval. Any blowoff discharge lines impacted must be modified accordingly at the expense of the project proponent.

8.0 Grading and Settlement

8.1 Changes in Cover over Metropolitan Pipelines

The existing cover over Metropolitan's pipelines must be maintained unless Metropolitan determines that proposed changes in grade and cover do not pose a hazard to the integrity of the pipeline or an impediment to its maintenance capability. Load and settlement or rebound due to change in cover over a Metropolitan pipeline or ground in the area of Metropolitan's rights-of-way will be factors considered by Metropolitan during project review.

In general, the minimum cover over a Metropolitan pipeline is 4 feet and the maximum cover varies per different pipeline. Any changes to the existing grade may require that Metropolitan's pipeline be potholed under Metropolitan's supervision to verify the existing cover.

8.2 Settlement

Any changes to the existing topography in the area of Metropolitan's pipeline or right-of-way that result in significant settlement or lateral displacement of Metropolitan's pipelines are not acceptable. Metropolitan may require submittal of a soils report showing the predicted settlement of the pipeline at 10-foot intervals for review. The data must be carried past the point of zero change in each direction and the actual size and varying depth of the fill must be considered when determining the settlement. Possible settlement due to soil collapse, rebound and lateral displacement must also be included.

In general, the typical maximum allowed deflection for Metropolitan's pipelines must not exceed a deflection of 1/4-inch for every 100 feet of pipe length. Metropolitan may require additional information per its Geotechnical Guidelines. Please contact Metropolitan's Substructures Team for a copy of the Geotechnical Guidelines.

9.0 Construction Equipment

9.1 Review of Proposed Equipment

Use of equipment across or adjacent to Metropolitan's facilities is subject to prior review and written approval by Metropolitan. Excavation, backfill, and other work in the vicinity of Metropolitan's facilities must be performed only by methods and with equipment approved by Metropolitan. A list of all equipment to be used must be submitted to Metropolitan a minimum of 30 days before the start of work.

- A. For equipment operating within paved public roadways, equipment that imposes loads not greater than that of an AASHTO H-20 vehicle (see Figure 1 on Page 21) may operate across or adjacent to Metropolitan's pipelines provided the equipment operates in non-vibratory mode and the road remains continuously paved.
- B. For equipment operating within unpaved public roadways, when the total cover over Metropolitan's pipeline is 10 feet or greater, equipment imposing loads no greater than those imposed by an AASHTO H-20 vehicle may operate over or adjacent to the pipeline provided the equipment is operated in non-vibratory mode. For crossings, vehicle path shall be maintained in a smooth condition, with no breaks in grade for 3 vehicle lengths on each side of the pipeline.

9.2 Equipment Restrictions

In general, no equipment may be used closer than 20 feet from all Metropolitan above-ground structures. The area around the structures should be flagged to prevent equipment encroaching into this zone.

9.3 Vibratory Compaction Equipment

Vibratory compaction equipment may not be used in vibratory mode within 20 feet of the edge of Metropolitan's pipelines.

9.4 Equipment Descriptions

The following information/specifications for each piece of equipment should be included on the list:

- A. A description of the equipment, including the type, manufacturer, model year, and model number. For example, wheel tractor-scraper, 1990 Caterpillar 627E.
- B. The empty and loaded total weight and the corresponding weight distribution. If equipment will be used empty only, it should be clearly stated.
- C. The wheel base (for each axle), tread width (for each axle), and tire footprint (width and length) or the track ground contact (width and length), and track gauge (center to center of track).

10.0 Excavations Close to Metropolitan Facilities

10.1 Shoring Design Submittal

Excavation that impacts Metropolitan's facilities requires that the contractor submit an engineered shoring design to Metropolitan for review and acceptance a minimum of 30 days before the scheduled start of excavation. Excavation may not begin until the shoring design is accepted in writing by Metropolitan.

Shoring design submittals must include all required trenches, pits, and tunnel or jacking operations and related calculations. Before starting the shoring design, the design engineer should consult with Metropolitan regarding Metropolitan's requirements, particularly as to any special procedures that may be required.

10.2 Shoring Design Requirements

Shoring design submittals must be stamped and signed by a California registered civil or structural engineer. The following requirements apply:

- A. The submitted shoring must provide appropriate support for soil adjacent to and under Metropolitan's facilities.
- B. Shoring submittals must include detailed procedures for the installation and removal of the shoring.
- C. Design calculations must follow the Title 8, Chapter 4, Article 6 of the California Code of Regulations (CCR) guidelines. Accepted methods of analysis must be used.
- D. Loads must be in accordance with the CCR guidelines or a soils report by a geotechnical consultant.
- E. All members must be secured to prevent sliding, falling, or kickouts.

Metropolitan's pipelines must be located by potholing under Metropolitan's supervision before the beginning construction. Use of driven piles within 20 feet of the centerline of Metropolitan's pipeline is not allowed. Piles installed in drilled holes must have a minimum 2-foot clearance between Metropolitan's pipeline and the edge of the drilled hole, and a minimum of 1-foot clearance between any part of the shoring and Metropolitan's pipeline.

11.0 Support of Metropolitan Facilities

11.1 Support Design Submittal

If temporary support of a Metropolitan facility is required, the contractor shall submit a support design plan to Metropolitan for review and approval a minimum of 30 days before the scheduled start of work. Work may not begin until the support design is approved in writing by Metropolitan. Before starting design, the design engineer should consult with Metropolitan regarding Metropolitan's requirements.

11.2 Support Design Requirements

Support design submittals must be prepared, stamped, and signed by a California registered civil or structural engineer. The following requirements apply:

- A. Support drawings must include detailed procedures for the installation and removal of the support system.
- B. Design calculations must follow accepted practices, and accepted methods of analysis must be used.
- C. Support designs must show uniform support of Metropolitan's facilities with minimal deflection.
- D. The total weight of the facility must be transferred to the support system before supporting soil is fully excavated.
- E. All members must be secured to prevent sliding, falling, or kickouts.

12.0 Backfill

12.1 Metropolitan Pipeline Not Supported

In areas where a portion of Metropolitan pipeline is not supported during construction, the backfill under and to an elevation of 6 inches above the top of the pipeline must be one-sack minimum cement sand slurry. To prevent adhesion of the slurry to Metropolitan's pipeline, a minimum 6-mil-thick layer of polyethylene sheeting or similar approved sheeting must be placed between the concrete support and the pipeline.

12.2 Metropolitan Pipeline Partially Exposed

In areas where a Metropolitan pipeline is partially exposed during construction, the backfill must be a minimum of 6 inches above the top of the pipeline with sand compacted to minimum 90 percent compaction.

12.3 Metropolitan Cut and Cover Conduit on Colorado River Aqueduct (CRA)

In areas where a Metropolitan cut and cover conduit is exposed, the following guidelines apply:

- A. No vehicle or equipment shall operate over or cross the conduit when the cover is less than 3 feet.
- B. Track-type dozer with a gross vehicle weight of 12,000 lbs or less may be used over the conduit when the cover is a minimum of 3 feet.
- C. Wheeled vehicles with a gross vehicle weight of 8,000 lbs or less may operate over the conduit when the cover is a minimum of 4 feet.
- D. Tracked dozer or wheeled vehicle should be used to push material over the conduit from the side.
- E. Tracked dozer or wheeled vehicle should gradually increase cover on one side of the conduit and then cross the conduit and increase cover on the other side of the conduit. The cover should be increased on one side of the conduit until a maximum of 2 feet of fill has been placed. The cover over the conduit is not allowed to be more than 2 feet higher on one side of the conduit than on the other side.
- F. The cover should be gradually increased over the conduit until the grade elevations have been restored.

13.0 Piles

13.1 Impacts on Metropolitan Pipelines

Pile support for structures could impose lateral, vertical and seismic loads on Metropolitan's pipelines. Since the installation of piles could also cause settlement of Metropolitan pipelines, a settlement and/or lateral deformation study may be required for pile installations within 50 feet of Metropolitan's pipelines. Metropolitan may require additional information per its Geo-technical Guidelines for pile installation. Please contact Metropolitan's Substructures Team for a copy of the Geotechnical Guidelines.

13.2 Permanent Cast-in-place Piles

Permanent cast-in-place piles must be constructed so that down drag forces of the pile do not act on Metropolitan's pipeline. The pile must be designed so that down drag forces are not developed from the ground surface to springline of Metropolitan's pipeline.

Permanent cast-in-place piles shall not be placed closer than 5 feet from the edge of Metropolitan's pipeline. Metropolitan may require additional information per its Geo-technical Guidelines for pile installation. Please contact Metropolitan's Substructures Team for a copy of the Geotechnical Guidelines.

14.0 Protective Slabs for Road Crossings Over Metropolitan Pipelines

Protective slabs must be permanent cast-in-place concrete protective slabs configured in accordance with Drawing SK-1 (See Figure 2 on Page 22).

The moments and shear for the protective slab may be derived from the American Association of State Highway and Transportation Officials (AASHTO). The following requirements apply:

- A. The concrete must be designed to meet the requirements of AASHTO
- B. Load and impact factors must be in accordance with AASHTO. Accepted methods of analysis must be used.
- C. The protective slab design must be stamped and signed by a California registered civil or structural engineer and submitted to Metropolitan with supporting calculations for review and approval.

Existing protective slabs that need to be lengthened can be lengthened without modification, provided the cover and other loading have not been increased.

15.0 Blasting

At least 90 days prior to the start of any drilling for rock excavation blasting, or any blasting in the vicinity of Metropolitan's facilities, a site-specific blasting plan must be submitted to Metropolitan for review and approval. The plan must consist of, but not be limited to, hole diameters, timing sequences, explosive weights, peak particle velocities (PPV) at Metropolitan pipelines/structures, and their distances to blast locations. The PPV must be estimated based on a site-specific power law equation. The power law equation provides the peak particle velocity versus the scaled distance and must be calibrated based on measured values at the site.

16.0 Metropolitan Plan Review Costs, Construction Costs and Billing

16.1 Plan Review Costs

Metropolitan plan reviews requiring 8 labor hours or less are generally performed at no cost to the project proponent. Metropolitan plan reviews requiring more than 8 labor hours must be paid by the project proponent, unless the project proponent has superior rights at the project area. The plan review will include a written response detailing Metropolitan's comments, requirements, and/or approval.

A deposit of funds in the amount of the estimated cost and a signed letter agreement will be required from the project proponent before Metropolitan begins or continues a detailed engineering plan review that exceeds 8 labor hours.

16.2 Cost of Modification of Facilities Performed by Metropolitan

Cost of modification work conducted by Metropolitan will be borne by the project proponent, when Metropolitan has paramount/prior rights at the subject location.

Metropolitan will transmit a cost estimate for the modification work to be performed (when it has paramount/prior rights) and will require that a deposit, in the amount of the estimate, be received before the work will be performed.

16.3 Final Billing

Final billing will be based on the actual costs incurred, including engineering plan review, inspection, materials, construction, and administrative overhead charges calculated in accordance with Metropolitan's standard accounting practices. If the total cost is less than the deposit, a refund will be made; however, if the cost exceeds the deposit, an invoice for the additional amount will be forwarded for payment.

17.0 Street Vacations and Reservation of Easements for Metropolitan

A reservation of an easement is required when all or a portion of a public street where Metropolitan facilities are located is to be vacated. The easement must be equal to the street width being vacated or a minimum 40 feet. The reservation must identify Metropolitan as a "public entity" and not a "public utility," prior to recordation of the vacation or tract map. The reservation of an easement must be submitted to Metropolitan for review prior to final approval.

18.0 Metropolitan Land Use Guidelines

If you are interested in obtaining permission to use Metropolitan land (temporary or long term), a Land Use Form must be completed and submitted to Metropolitan for review and consideration. A nonrefundable processing fee is required to cover Metropolitan's costs for reviewing your request. Land Use Request Forms can be found at:

http://mwdh2o.com/PDF_Doing_Your_Business/4.7.1_Land_Use_Request_form_revised.pdf

The request should be emailed to RealEstateServices@mwdh2o.com, or contact the Real Property Development and Management (RPDM) Group at (213) 217-7750.

After the initial application form has been submitted, Metropolitan may require the following in order to process your request:

- A. A map indicating the location(s) where access is needed, and the location & size (height, width and depth) of any invasive subsurface activity (boreholes, trenches, etc.).
- B. The California Environmental Quality Act (CEQA) document(s) or studies that have been prepared for the project (e.g., initial study, notice of exemption, Environmental Impact Report (EIR), Mitigated Negative Declaration (MND), etc.).
- C. A copy of an ACORD insurance certification naming Metropolitan as an additional insured, or a current copy of a statement of self-insurance.
- D. Confirmation of the legal name of the person(s) or entity(ies) that are to be named as the permittee(s) in the entry permit.
- E. Confirmation of the purpose of the land use.
- F. The name of the person(s) with the authority to sign the documents and any specific signature title block requirements for that person or any other persons required to sign the document (i.e., legal counsel, Board Secretary/Clerk, etc.).
- G. A description of any vehicles that will have access to the property. The exact make or model information is not necessary; however, the general vehicle type, expected maximum dimensions (height, length, width), and a specific maximum weight must be provided.

Land use applications and proposed use of the property must be compatible with Metropolitan's present and/or future use of the property. Any preliminary review of your request by Metropolitan shall not be construed as a promise to grant any property rights for the use of Metropolitan's property.

19.0 Compliance with Environmental Laws and Regulations

As a public agency, Metropolitan is required to comply with all applicable environmental laws and regulations related to the activities it carries out or approves. Consequently, project plans, maps, and other information must be reviewed to determine Metropolitan's obligations pursuant to state and federal environmental laws and regulations, including, but not limited to:

- A. California Environmental Quality Act (CEQA) (Public Resources Code 21000-21177) and the State CEQA Guidelines (California Code of Regulations, Title 14, Division 6, Chapter 3, Sections 1500-15387)
- B. Federal Endangered Species Act (ESA) of 1973, 16 U.S.C. §§ 1531, et seq.
- C. California Fish and Game Code Sections 2050-2069 (California ESA)
- D. California Fish and Game Code Section 1602
- E. California Fish and Game Code Sections 3511, 4700, 5050 and 5515 (California fully protected species)
- F. Federal Migratory Bird Treaty Act (MBTA), 16 U.S.C. §§ 703-712
- G. Federal Clean Water Act (including but not limited to Sections 404 and 401) 33 U.S.C. §§ 1342, 1344)

- H. Porter Cologne Water Quality Control Act of 1969, California Water Code §§ 13000-14076.
- I. Title 22, California Code of Regulations, Chapter 16 (California Waterworks Standards), Section 64572 (Water Main Separation)

Metropolitan may require the project applicant to pay for any environmental review, compliance and/or mitigation costs incurred to satisfy such legal obligations.

20.0 Paramount Rights / Metropolitan's Rights within Existing Rights-of-Way

Facilities constructed within Metropolitan's rights-of-way shall be subject to the paramount right of Metropolitan to use its rights-of-way for the purpose for which they were acquired. If at any time Metropolitan or its assigns should, in the exercise of their rights, find it necessary to remove or relocate any facilities from its rights-of-way, such removal and replacement or relocation shall be at the expense of the owner of the facility.

21.0 Disclaimer and Information Accuracy

Metropolitan assumes no responsibility for the accuracy of the substructure information herein provided. The user assumes responsibility for verifying substructure locations before excavating and assumes all liability for damage to Metropolitan's facilities as a result of such excavation. Additionally, the user is cautioned to conduct surveys and other field investigations as you may deem prudent, to assure that your project plans are correct. The relevant representative from Metropolitan must be called at least two working days, before any work activity in proximity to Metropolitan's facilities.

It generally takes 30 days to review project plans and provide written responses. Metropolitan reserves the right to modify requirements based on case-specific issues and regulatory developments.

Table 1: General Guidelines for Pipeline Separation between Metropolitan’s Pipeline¹ and Sanitary Sewer² or Hazardous Fluid Pipeline³

<p><u>Pipeline Crossings</u></p>	<p>Metropolitan requires that sanitary sewer and hazardous fluid pipelines that cross Metropolitan’s pipelines have special pipe construction (no joints) and secondary containment⁴. This is required for the full width of Metropolitan’s rights-of-way or within 10 feet tangent to the outer edges of Metropolitan’s pipeline within public streets. Additionally, sanitary sewer and hazardous fluid pipelines crossing Metropolitan’s pipelines must be perpendicular and maintain a minimum 1-foot vertical clearance between the top and the bottom of Metropolitan’s pipeline and the pipe casing.</p> <p>These requirements apply to all sanitary sewer crossings regardless if the sanitary sewer main is located below or above Metropolitan’s pipeline.</p>
<p><u>Parallel Pipeline</u></p>	<p>Metropolitan generally does not permit the installation of longitudinal pipelines along its rights-of-way. Within public streets, Metropolitan requires that all parallel sanitary sewer, hazardous fluid pipelines and/or non-potable utilities be located a minimum of 10 feet from the outside edges of Metropolitan’s pipelines. When 10-foot horizontal separation criteria cannot be met, longitudinal pipelines require special pipe construction (no joints) and secondary containment⁴.</p>
<p><u>Sewer Manhole</u></p>	<p>Sanitary sewer manholes are not allowed within Metropolitan’s rights-of-way. Within public streets, Metropolitan requests manholes parallel to its pipeline be located a minimum of 10 feet from the outside edges of its pipelines. When 10 foot horizontal separation criteria cannot be met, the structure must have secondary containment⁵.</p>

Notes:

¹ Separation distances are measured from the outer edges of each pipe.

² Sanitary sewer requirements apply to all recycled water treated to less than disinfected tertiary recycled water (disinfected secondary recycled water or less). Recycled water definitions are included in Title 22, California Code of Regulations, Chapter 3 (Water Recycling Criteria), Section 60301.

³ Hazardous fluids include e.g., oil, fuels, chemicals, industrial wastes, wastewater sludge, etc.

⁴ Secondary Containment for Pipeline - Secondary containment consists of a continuous pipeline sleeve (no joints). Examples acceptable to Metropolitan include welded steel pipe with grout in annular space and cathodic protection (unless coated with non-conductive material) and High Density Polyethylene (HDPE) pipe with fusion-welded joints.

⁵ Secondary Containment for Structures – Secondary containment consists of external HDPE liner or other approved method.

Table 2: General Guidelines for Pipeline Separation between Metropolitan’s Pipeline¹ and Storm Drain and/or Disinfected Tertiary Recycled Water²

<p><u>Pipeline Crossings</u></p>	<p>Metropolitan requires crossing pipelines to be special pipe construction (no joints) or have secondary containment³ within 10-feet tangent to the outer edges of Metropolitan’s pipeline. Additionally, pipelines crossing Metropolitan’s pipelines must be perpendicular and maintain a minimum 1-foot vertical clearance.</p>
<p><u>Parallel Pipeline</u></p>	<p>Metropolitan generally does not permit the installation of longitudinal pipelines along its rights-of-way. Within public streets, Metropolitan requests that all parallel pipelines be located a minimum of 10 feet from the outside edges of Metropolitan’s pipelines. When 10-foot horizontal separation criteria cannot be met, special pipe construction (no joints) or secondary containment³ are required.</p>
<p><u>Storm Drain Manhole</u></p>	<p>Permanent utility structures (e.g., manhole, catch basin, inlets) are not allowed within Metropolitan’s rights-of-way. Within public streets, Metropolitan requests all structures parallel to its pipeline be located a minimum of 10 feet from the outside edges of its pipelines. When 10 foot horizontal separation criteria cannot be met, the structure must have secondary containment⁴.</p>

Notes:

¹ Separation distances are measured from the outer edges of each pipe.

² Disinfected tertiary recycled water as defined in Title 22, California Code of Regulations, Chapter 3 (Water Recycling Criteria), Section 60301.

³ Secondary Containment for Pipeline - Secondary containment consists of a continuous pipeline sleeve (no joints). Examples acceptable to Metropolitan include welded steel pipe with grout in annular space and cathodic protection (unless coated with non-conductive material) and High Density Polyethylene (HDPE) pipe with fusion-welded joints.

⁴ Secondary Containment for Structures – Secondary containment consists of external HDPE liner or other approved method.

Table 3: General Guidelines for Pipeline Separation¹ between Metropolitan’s Pipeline and Recycled Water^{2,4} Irrigations

<p>Pressurized recycled irrigation mainlines</p>	<ul style="list-style-type: none"> • Crossings - must be perpendicular and maintain a minimum 1-foot vertical clearance. Crossing pressurized recycled irrigation mainlines must be special pipe construction (no joints) or have secondary containment³ within 10-feet tangent to the outer edges of Metropolitan’s pipeline. • Longitudinal - must maintain a minimum 10-foot horizontal separation and route along the perimeter of Metropolitan’s rights-of-way where possible.
<p>Intermittently Energized Recycled Water Irrigation System Components</p>	<ul style="list-style-type: none"> • Crossings - must be perpendicular and maintain a minimum 1-foot vertical clearance. Crossing irrigation laterals within 5-feet tangent to the outer edges of Metropolitan’s pipeline must be special pipe construction (no joints) or have secondary containment³. • Longitudinal – must maintain a minimum 5-foot horizontal separation between all intermittently energized recycled water irrigation system components (e.g. irrigation lateral lines, control valves, rotors) and the outer edges of Metropolitan’s pipeline. Longitudinal irrigation laterals within 5-feet tangent to the outer edges of Metropolitan’s pipeline must be special pipe construction (no joints) or have secondary containment³.
<p>Irrigation Structures</p>	<p>Irrigation structures such as meters, pumps, control valves, etc. must be located outside of Metropolitan’s rights-of-way.</p>
<p>Irrigation spray rotors near Metropolitan’s aboveground facilities</p>	<p>Irrigation spray rotors must be located a minimum of 20-foot from any Metropolitan above ground structures with the spray direction away from these structures. These rotors should be routinely maintained and adjusted as necessary to ensure no over-spray into 20-foot clear zones.</p>
<p>Irrigations near open canals and aqueducts</p>	<p>Irrigation with recycled water near open canals and aqueducts will require a setback distance to be determined based on site-specific conditions. Runoff of recycled water must be contained within an approved use area and not impact Metropolitan facilities.</p> <p>Appropriate setbacks must also be in place to prevent overspray of recycled water impacting Metropolitan’s facilities.</p>

Notes:

¹ Separation distances are measured from the outer edges of each pipe.

² Requirements for recycled water irrigation apply to all levels of treatment of recycled water for non-potable uses. Recycled water definitions are included in Title 22, California Code of Regulations, Chapter 3 (Water Recycling Criteria), Section 60301.

³ Secondary Containment for Pipeline - Secondary containment consists of a continuous pipeline sleeve (no joints). Examples acceptable to Metropolitan include welded steel pipe with grout in annular space and cathodic protection (unless coated with non-conductive material) and High Density Polyethylene (HDPE) pipe with fusion-welded joints.

⁴ Irrigation with recycled water shall not be applied directly above Metropolitan’s treated water pipelines.

Figure 1: AASHTO H-20 Loading

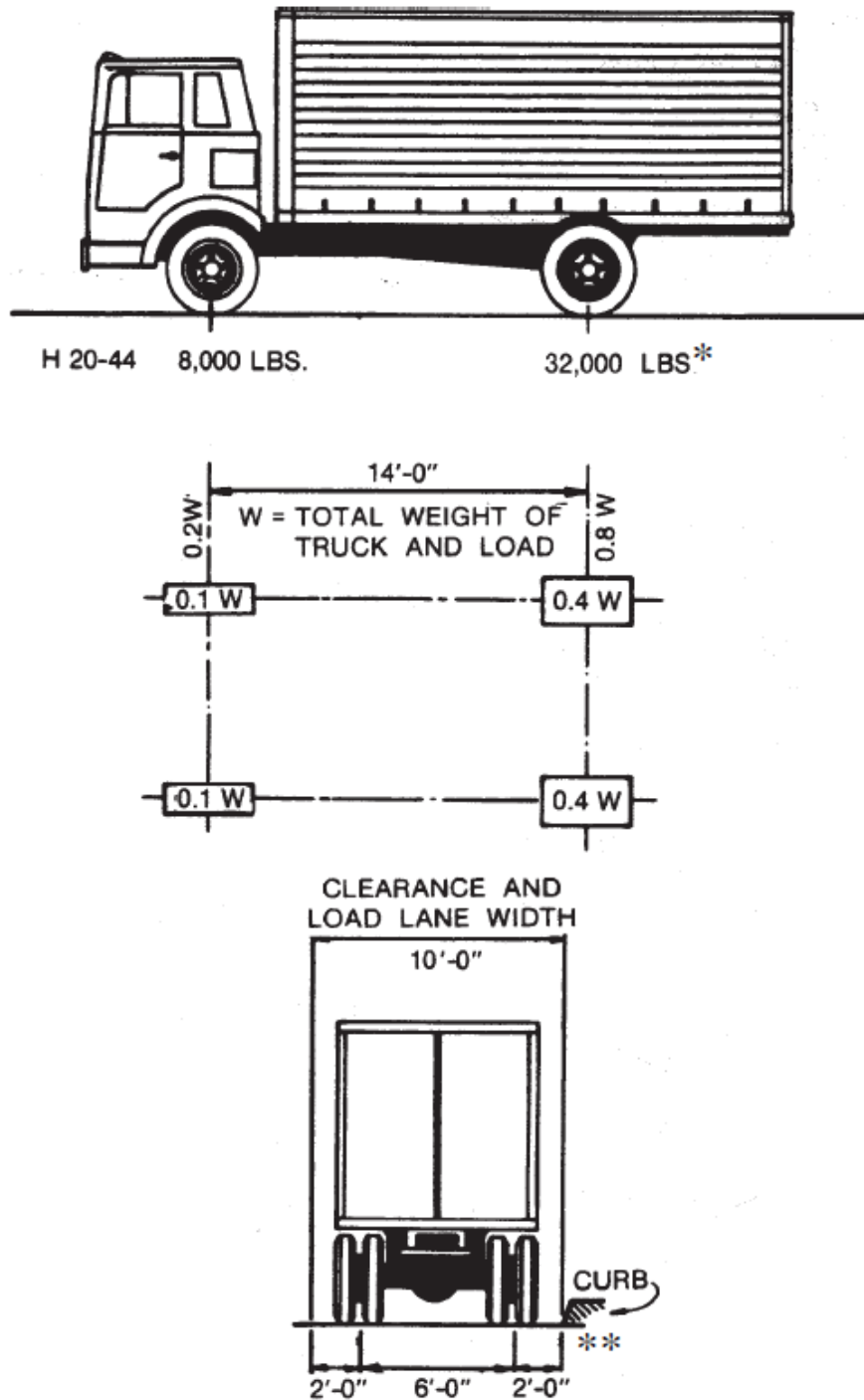

Note: The H loadings consist of a two-axle truck or the corresponding lane loadings as illustrated above. The H loadings are designated "H" followed by a number indicating the gross weight in tons of the standard truck.

Figure 2: Drawing SK-1

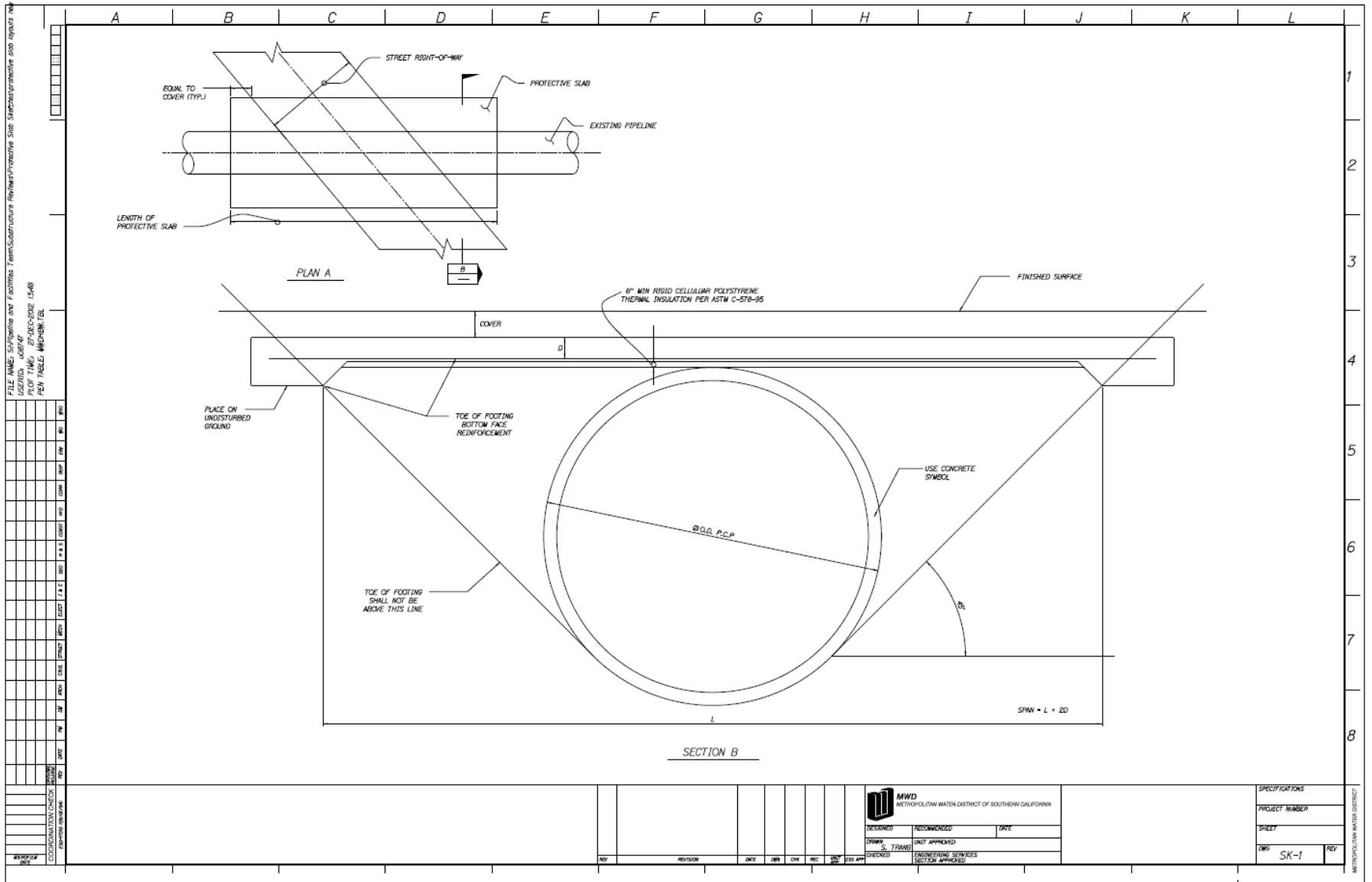

Project Name

Brightline West – Victorville to Las Vegas
and Victorville to Rancho Cucamonga

Date

07/18/2022



Regarding

MWD Waterline

From

Murali Hariharan, PE, GE, HNTB

To

Chao Chen, PE, HNTB
Yung-Nien Wang, PE, HNTB

Cc

James Van Wormer, PE, HNTB
Shahram Vahdat, PE, HNTB

File: 75761

Memorandum

The Brightline West project is a high-speed rail project from Las Vegas to Rancho Cucamonga. The project is within the median of the I-15 Freeway. In the city of Fontana between Duncan Canyon Road Bridge and the Summit Avenue Road Bridge in the vicinity of track station 11217+66, the Brightline West (BLW) track goes over an existing Metropolitan Water District of Southern California (MWD) waterline. This existing line was built before the current I-15 highway was built. The track is a double track at this location. MWD has requested an analysis of the potential effects of the track loading on their line. This memorandum presents analysis results of the stresses and settlement of the waterline due to load impacts from the BLW track.

1.0 EXISTING 96 INCH WATERLINE

As-builts for the existing 96-inch line are as shown in Appendix A. The line is a typical prestressed concrete water pipeline with an 8.5" thick wall and encased in concrete (MWD Class 3) under the extents of the I-15 highway. The pipe has bell and spigot joints. The joint spacing is not known but assumed to be 20 feet. The encasement is bar reinforced. The concrete strength of the encasement is also not known but is assumed to be 3000 psi 28-day compressive strength for analysis purposes. The line was built circa 1969. Based on our understanding and discussions with MWD, no condition assessments are available for the line.

A field measurement was obtained by BLW on July 13th, 2022, on the depth to the top of the encasement at the manhole at MWD Station 3636+48. The measurement indicated that the top of the encasement is 10'-4" below the manhole lid. The lid is at-grade. Under the I-15 the line has a maximum cover of approx. 16 feet. The other stations at which a depth measurement was obtained were 3626+05 and 3617+00 but these stations are much beyond the I-15 footprint, our area of interest.

The existing and proposed highway and track configuration is shown on Figure 1.

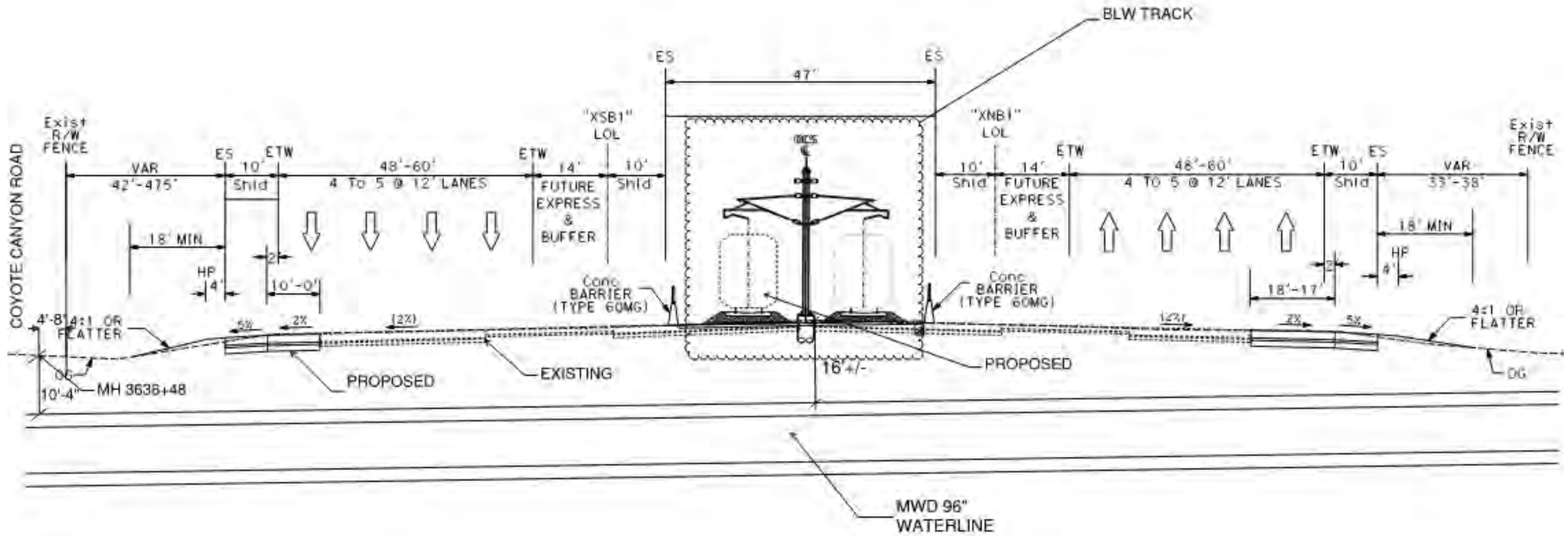
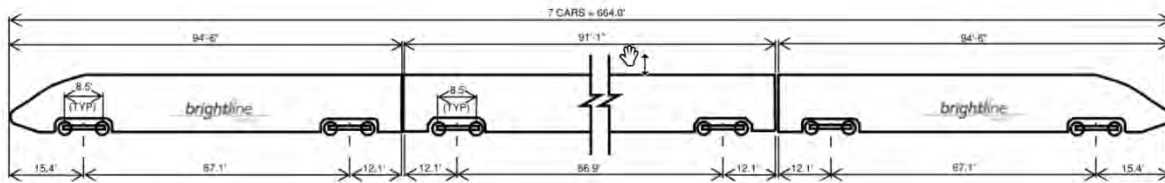

FIGURE 1: EXISTING AND PROPOSED HIGHWAY AND TRACK SECTIONS

2.0 BACKGROUND AND ANALYSES CONSIDERATIONS

Per MWD the line is designed for a Cooper E-60 load. See letter attached in Appendix A. With respect to MWD, the two critical trainsets are – the high-speed train which is the Siemens NOVO train with a maximum axle load of 19 tons or 38 kips and a maintenance train with a maximum axle load of 72.2 kips. The train speed is 125 to 155 miles per hour for the NOVO train and typical freight speeds or slower for the maintenance train. The site soils as shown on MWD drawing B-56440 are generally granular – silty sand with gravel and sandy gravels. It is expected that the backfill of the pipeline was also granular.



Maximum Axle Load = 19 tons

Train Weight (Empty) = 443 tons

FIGURE 2: BLW HIGH SPEED TRAIN – SIEMENS NOVO

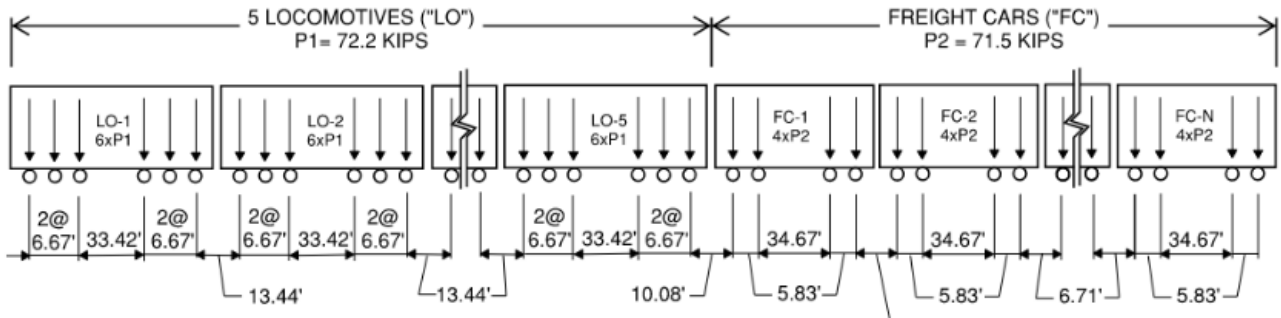

FIGURE 3: BLW MAINTENANCE TRAIN – DIESEL LOCOMOTIVE

High speed rail has special considerations with respect to Shear Wave and Rayleigh Wave Velocities of the subgrade for rail settlement. There are also considerations with respect to large diameter underground utilities that may pose a hard point to the rail line.

The dynamic subgrade properties are however important only to approx. 10 feet of subgrade under the rail. The rail line is in the median in between the I-15 NB and SB and at grade. In Appendix A, the profile

of the line is shown. Generally, the line is deeper than 10 feet below the highway grade. The MWD line therefore has no impact on the dynamic properties of the subgrade as it pertains to the BLW track.

The hard point considerations do not apply due to the presence of sufficient cover over the MWD line. Site soils are granular and therefore do not pose any long term or plastic settlement issues. Therefore, no ground modification is required around the MWD line. Track construction will also not impact the MWD line.

The only considerations will then be the load exerted by track on the MWD line, its transverse impact which is the encasement stresses and its longitudinal impact which is the settlement/joint opening of the line under load. Therefore, the controlling train load for analysis is the heavier maintenance train.

2.1 TRANSVERSE ANALYSIS

In the transverse analysis it is assumed that the encasement will resist the loads imposed by the BLW track and the overlying soils. The loading is both vertical and lateral. This is a valid assumption since the line was expressly encased in reinforced concrete under the extents of the future I-15 highway when the line was built. The analysis model in SAP 2000 is shown on Figure 4. Model details, geotechnical parameters, load calculations and analyses details are in Appendix B.

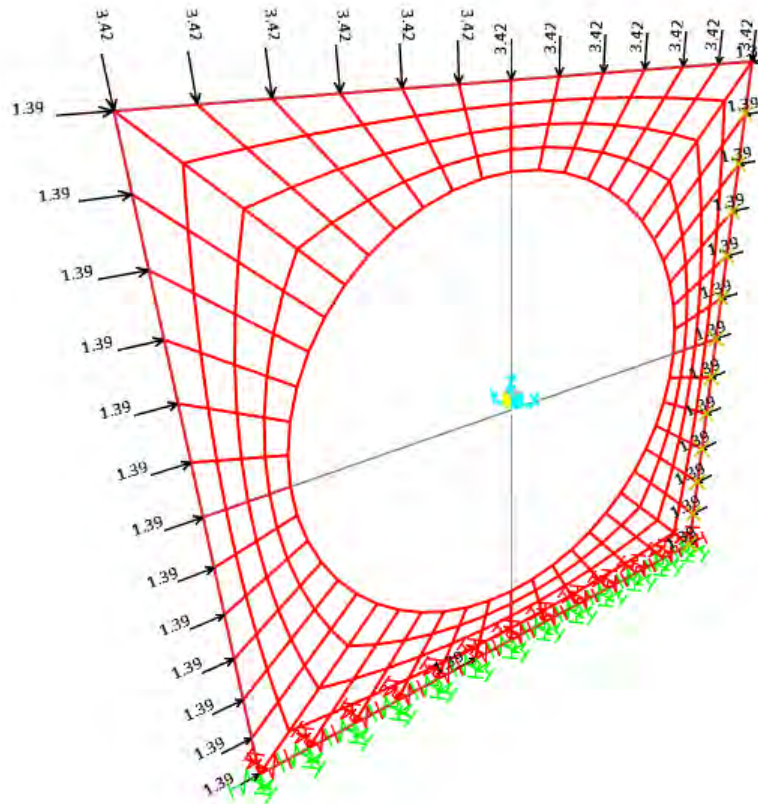

FIGURE 4: ENCASEMENT LOADS

Under the vertical and lateral loads, the crown section of the encasement and the invert will undergo bending and produce a tension on the inside face condition. The side wall will be under bending and thrust. The thrust develops since the total vertical load is transferred through the sidewalls to the invert. In the sidewall the tension develops on the outside or soil face. The Class 3 encasement is reinforced with Class 3 encasement is reinforced with #9 bars at 6" at the crown on the inside and invert on the inside and #8 bars at 6 inches on the outside of the sidewalls. The following table summarizes the induced moments and the moment capacities. Results are per the Load and Resistance Factor methodology with a load factor of 2.33 per AREMA. See Appendix B for details. Shear is not an issue by inspection in all cases. From Table 1 the encasement is more than adequate for the BLW track loads.

	Moment			Remark
	Capacity	Demand	D/C Ratio	
	k-ft	k-ft	(<1.0 Req'd)	
CROWN/INVERT	108.35	36.86	0.34	OK
SIDEWALL	88.53	31.23	0.35	OK

TABLE 1: TRANSVERSE ANALYSES RESULTS

2.3 LONGITUDINAL ANALYSES RESULTS

In the longitudinal direction the pipe is discontinuous and therefore the analysis is one of joint opening. Based on our research of current Prestressed Concrete Pipe Standards (Prestressed Concrete Pressure Pipe Engineering Manual, 10th Edition. A Thompson Group Publication.) 0.5" joint opening may be acceptable in addition to the opening tolerances at the time of pipe construction and setting. The benefits of the encasement are ignored for this analysis.

Settlement modulus (Constrained Modulus) of the soil, based on our experience and review of the MWD soil profile presented on drawing B56440 and nearby Caltrans Bridges, is used as 500 ksf. This represents a low value of Modulus. In general, based the SPT "N" values in the boring logs in Appendix B, the modulus values can be from 1500 ksf to 3000 ksf in the large settlement range. Caltrans Bridge borings for the Duncan Canyon Bridge (called Citrus Avenue historically) to the North and the Summit Avenue Bridge to the South are also presented in Appendix B. The stress increase and the modulus values can be used to calculate a strain value which when multiplied by the layer thickness provides the settlement.

To assess joint opening, it is assumed that there is one joint directly under the center of the track load and the other joints are 20 feet apart. Assess settlement at the underside of the encasement at the center and 20 feet away. Assume then the line has a kink at the center of the load and use that to determine the deflection angle and potential joint opening number from current Prestressed Concrete Cylinder Pipe charts. Analyses details are in Appendix B. Settlement is assessed using the Boussinesq equation for a strip load. The stress increases for a depth equal to encasement height below the encasement is calculated using the Boussinesq equation at the load center and at a point 20 ft from the load center. At this depth equal to the encasement width, the stress increase reduces to 10% of the applied load.

Based on the calculations in Appendix B, the maximum settlement under load center is 0.19" and that 20 ft away is 0.1 inch. Over a 20 foot pipe length this translates into a 0.02 degree joint opening. Based on the PCCP charts in Appendix B, if a 0.5" additional joint opening is permitted to occur then the additional angular joint opening that may be permitted is 0.28 degree. The calculated additional joint opening is 0.02 degree which is far smaller than the 0.28 degree value. There is no consequence then of the small additional settlement that may occur due to the BLW track loads.

3.0 SUMMARY AND CONCLUSIONS

In summary based on the foregoing analyses, the concrete encasement of the MWD waterline has more than adequate reinforcement to resist the loads imposed by the BLW track. Additionally, the settlement of the line due to track load is expected to be on the order of 0.2" or less. For this settlement, the predicted joint opening, ignoring any benefit from the encasement, is expected to be on the order of 0.02 degrees. This is much smaller than a 0.28 degree that may be allowed assuming another 0.5" joint opening – as is typically allowed for all prestressed concrete pipe – may be permitted.

APPENDIX A

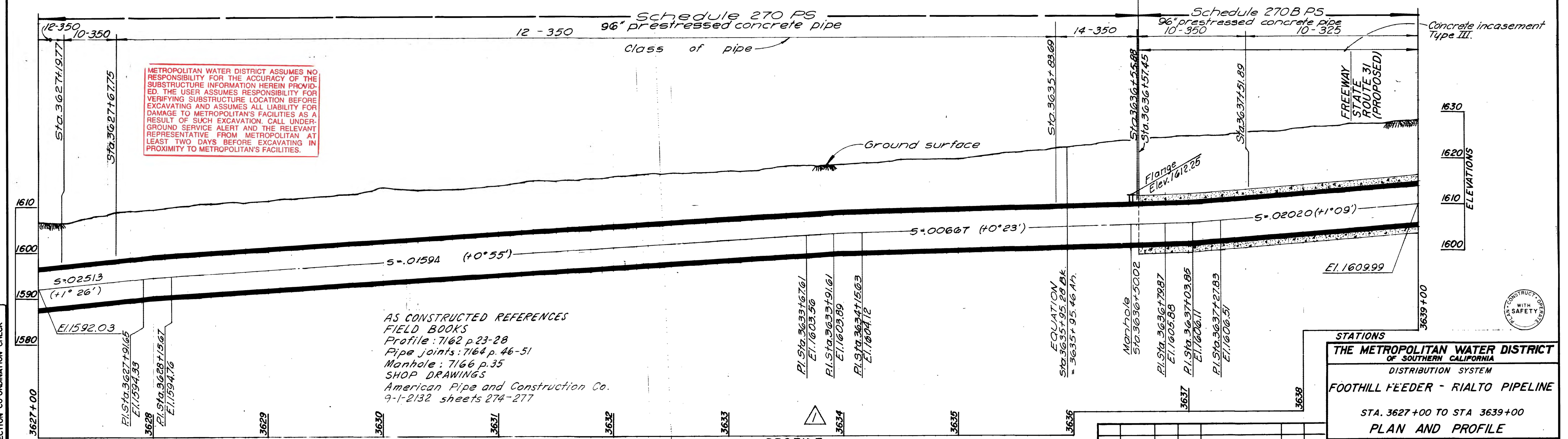
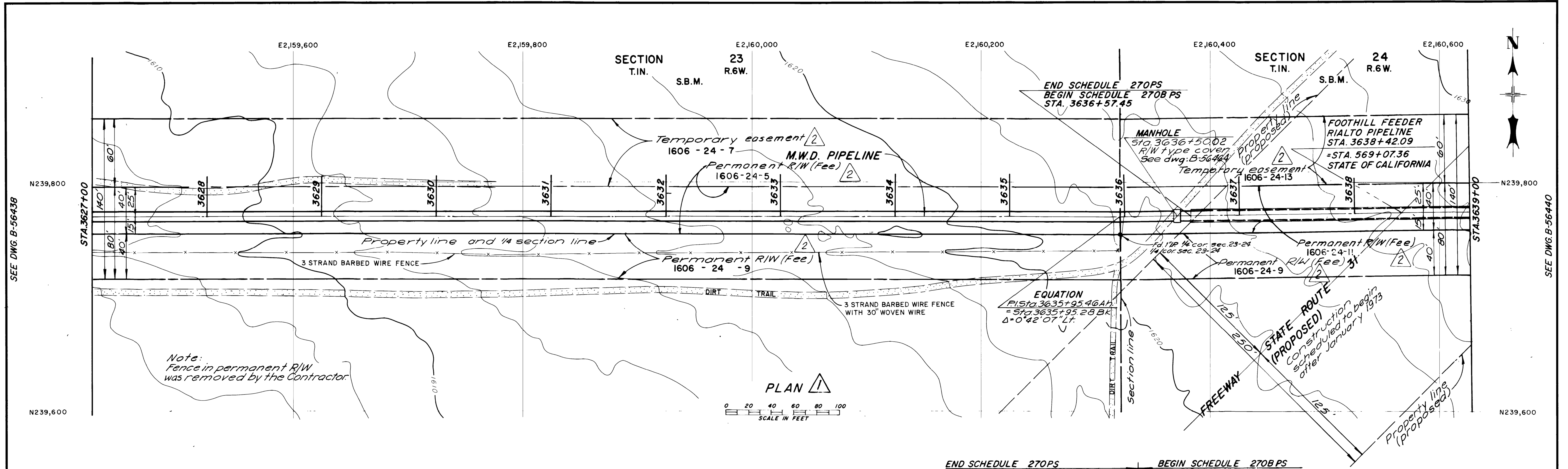

METROPOLITAN WATER DISTRICT ASSUMES NO RESPONSIBILITY FOR THE ACCURACY OF THE SUBSTRUCTURE INFORMATION HEREIN PROVIDED. THE USER ASSUMES RESPONSIBILITY FOR VERIFYING SUBSTRUCTURE LOCATION BEFORE EXCAVATING AND ASSUMES ALL LIABILITY FOR DAMAGE TO METROPOLITAN'S FACILITIES AS A RESULT OF SUCH EXCAVATION. CALL UNDERGROUND SERVICE ALERT AND THE RELEVANT REPRESENTATIVE FROM METROPOLITAN AT LEAST TWO DAYS BEFORE EXCAVATING IN PROXIMITY TO METROPOLITAN'S FACILITIES.

AS CONSTRUCTED REFERENCES
 FIELD BOOKS
 Profile: 7162 p.23-28
 Pipe joints: 7164 p.46-51
 Manhole: 7166 p.35
 SHOP DRAWINGS
 American Pipe and Construction Co.
 9-1-2132 sheets 274-277

PROFILE
 Stationing and elevations apply to axis of pipe.
 Revised to show pipeline as constructed.
 For detail design of pipe see drawings: B-56457 and B-56458.

NO.	DATE	DWN.	CHKD.	REVISION	REC.	APP.
1	10-27-78	S.I.	WPL	Revised R/W	WPL	WPL
2	4-17-72	F.J.D.	WPL	As constructed	WPL	WPL

STATIONS
THE METROPOLITAN WATER DISTRICT
 OF SOUTHERN CALIFORNIA
 DISTRIBUTION SYSTEM
FOOTHILL FEEDER - RIALTO PIPELINE
 STA. 3627+00 TO STA. 3639+00
PLAN AND PROFILE

DRAWN: L.V.B. B.S.T. J.E.H.
 TRACED: A.L.
 CHECKED: [Signature]
 RECOMMENDED: [Signature]
 APPROVED: [Signature]

W.O. 5-3622 LOS ANGELES APRIL 1969 B-56439

REVISION COORDINATION CHECK	
ORIGINAL	
RELEASE	
MECH. STRUC. ELEC. CIVIL	
INTER-SECTION COORDINATION CHECK	

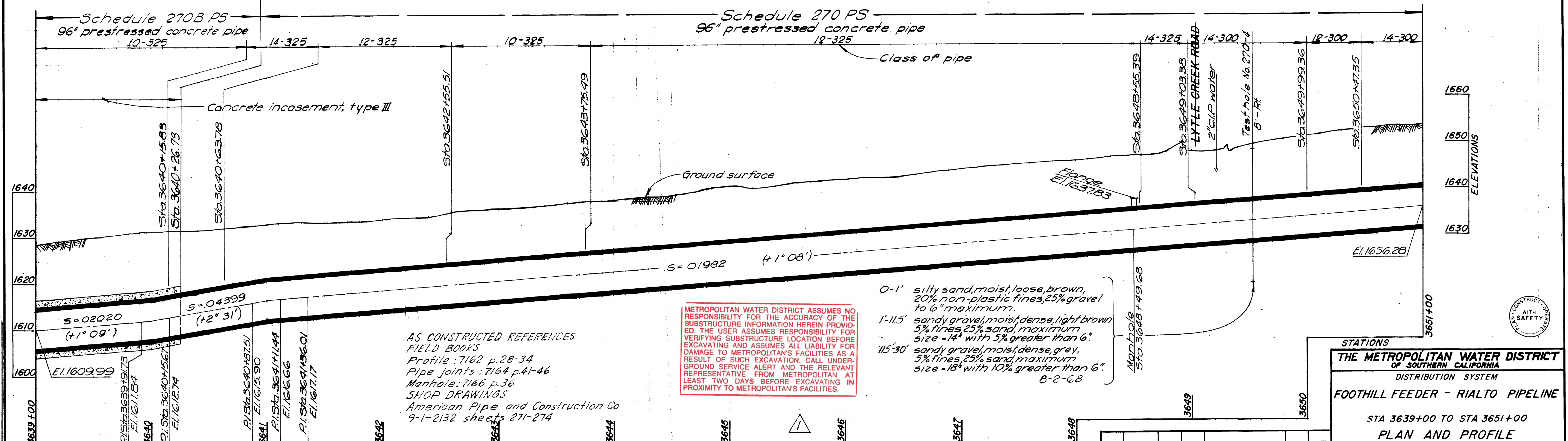
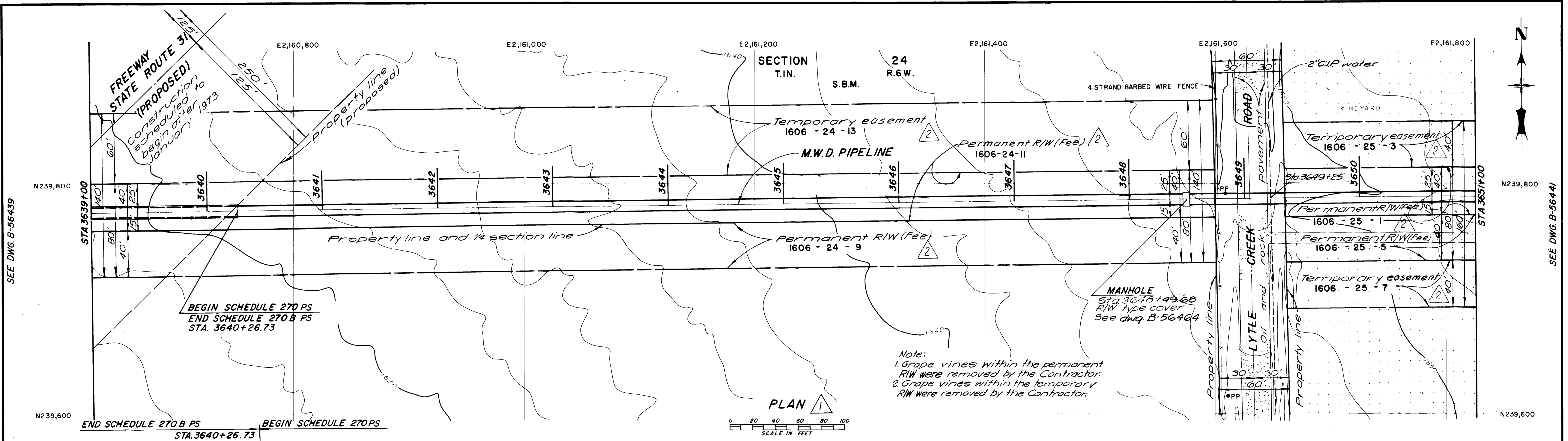

AS CONSTRUCTED REFERENCES
 FIELD BOOKS
 Profile: 7162 p.28-34
 Pipe joints: 7164 p.41-46
 Manhole: 7166 p.36
 SHOP DRAWINGS
 American Pipe and Construction Co
 9-1-2132 sheets 271-274

METROPOLITAN WATER DISTRICT ASSUMES NO RESPONSIBILITY FOR THE ACCURACY OF THE SUBSTRUCTURE INFORMATION HEREIN PROVIDED. THE USER ASSUMES RESPONSIBILITY FOR VERIFYING SUBSTRUCTURE LOCATION BEFORE EXCAVATING AND ASSUMES ALL LIABILITY FOR DAMAGE TO METROPOLITAN'S FACILITIES AS A RESULT OF SUCH EXCAVATION. CALL UNDERGROUND SERVICE ALERT AND THE RELEVANT REPRESENTATIVE FROM METROPOLITAN AT LEAST TWO DAYS BEFORE EXCAVATING IN PROXIMITY TO METROPOLITAN'S FACILITIES.

0-1' silty sand, moist, loose, brown, 20% non-plastic fines, 25% gravel to 6" maximum.
 1-11.5' sandy gravel, moist, dense, light brown 5% fines, 25% sand, maximum size = 1/4" with 5% greater than 6".
 11.5-30' sandy gravel, moist, dense, grey, 5% fines, 25% sand, maximum size = 1/4" with 10% greater than 6".

STATIONS
 FIELD BOOKS
 Alignment: 6013 p.10-11
 Profile: 5992 p.47-52

PROFILE
 Stationing and elevations apply to axis of pipe.
 Revised to show pipeline as constructed
 For detail design of pipe see drawings B-56457 and B-56458

NO.	DATE	DWN.	CHKD.	REVISION	REC.	APP.
1	10-27-78	S.I.		Revised R/W		
2	4-17-72	FCB		As constructed		

STATIONS
THE METROPOLITAN WATER DISTRICT
 OF SOUTHERN CALIFORNIA
 DISTRIBUTION SYSTEM
FOOTHILL FEDER - RIALTO PIPELINE
 STA 3639+00 TO STA 3651+00
PLAN AND PROFILE

DRAWN L.K.B. BY T. J. V. RECOMMENDED BY J. M. W. W. W.
 TRACED A.L. CHECKED BY S. M. S. APPROVED BY S. M. S. 992
 W.O. 5-3632 LOS ANGELES APRIL 1969 B-56440

CHICAGO AERIAL SURVEY
 PROJECT NO. 6486-60
 FEB 1 1977

SEE DWG. B-56439

SEE DWG. B-56441

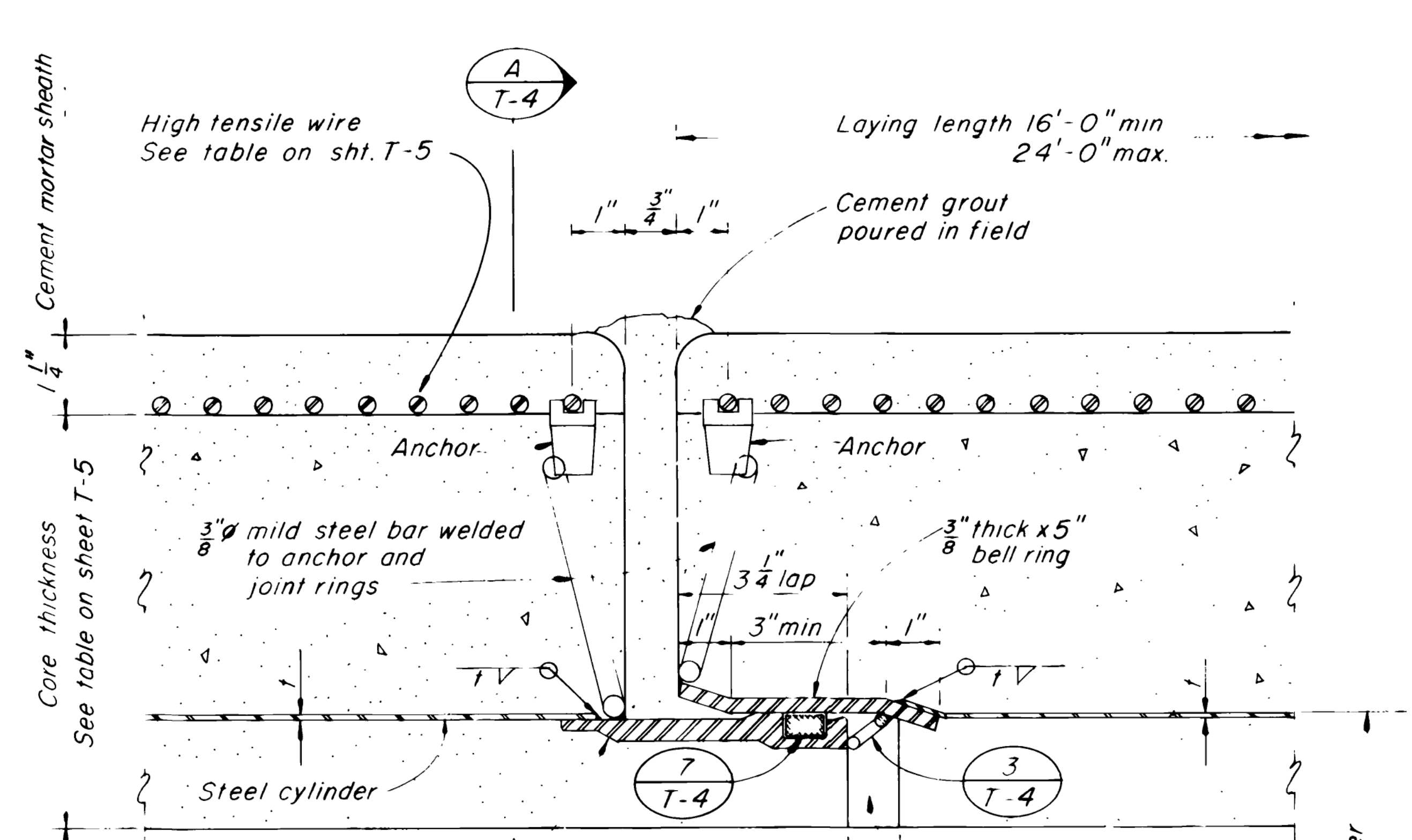

CRADLE DATA		
Degree of Cradle	$\frac{\Delta}{2}$	Material
110	55	Soil cement
120	60	Soil cement
140	70	Concrete
180	90	Concrete

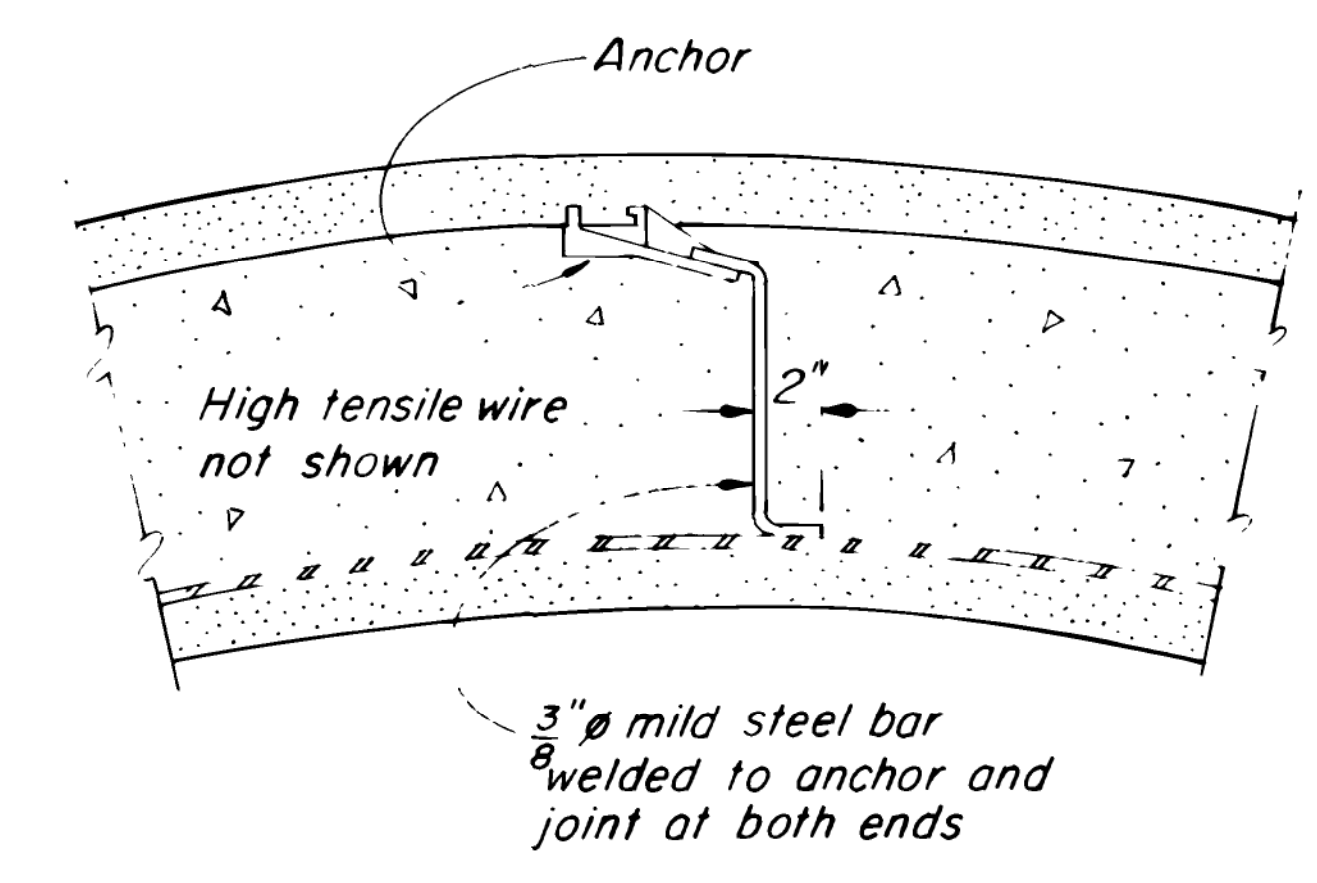
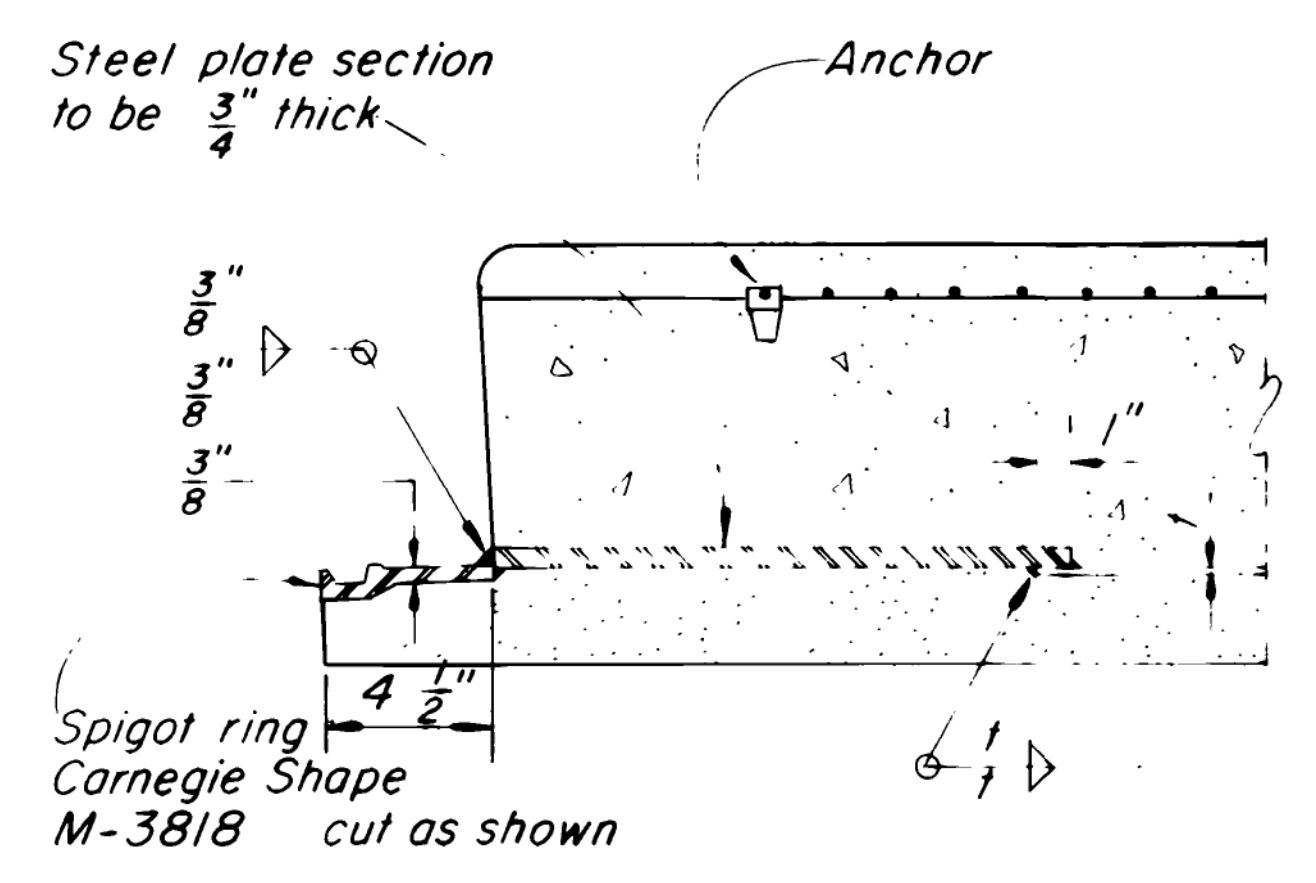
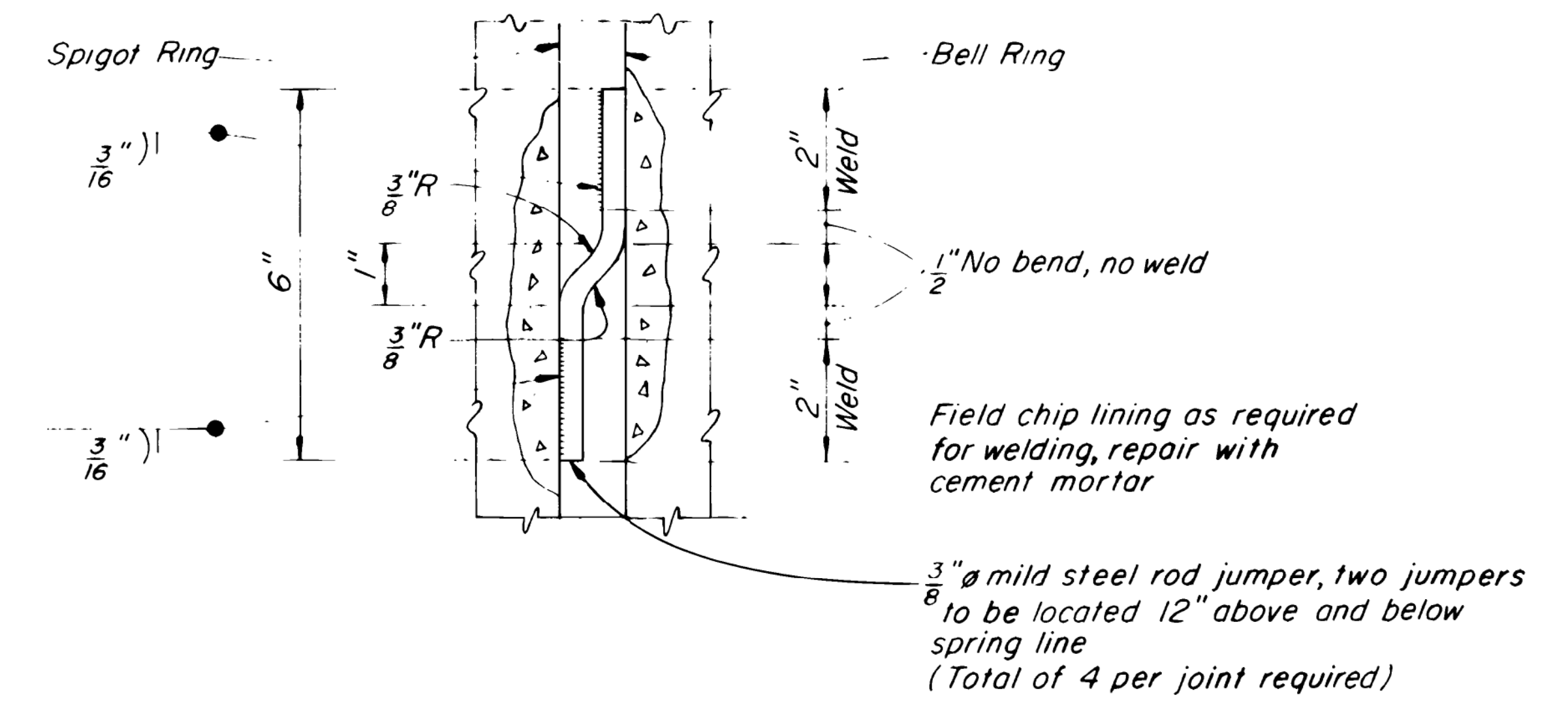
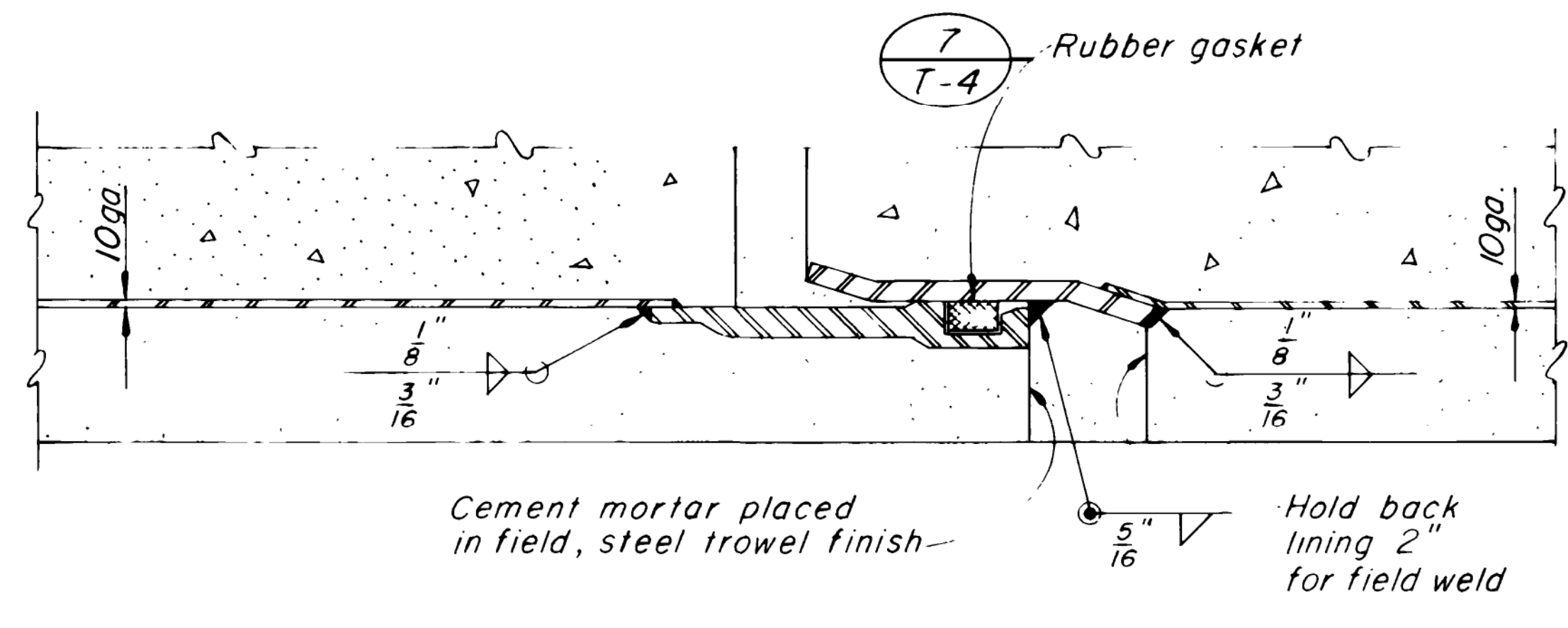
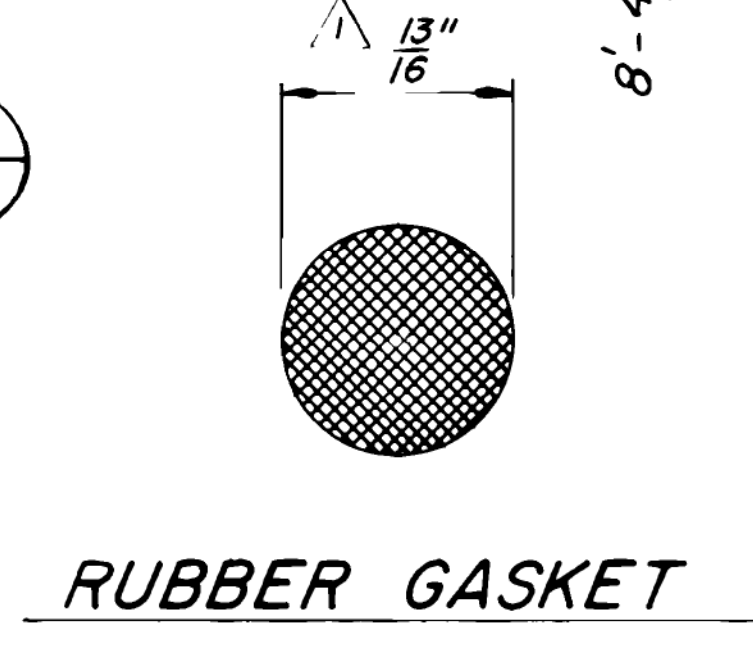

- NOTES:**
- All cylinders to be 14 gage except where welded lock joints are shown on the plan and profile drawings. At these locations the cylinder shall be 10 gage. This is indicated by 10 following the class of pipe: e.g. 14-125-10 indicates class 14-125 pipe with 10 gage cylinder.
 - Center to center spacing of high tensile wires shall be that which provides a clear distance of not less than 3/16" between the wires. Center to center spacing shall not exceed 1 1/2" for #8 and 6" wire and 1" for all wire sizes larger than #6.
 - For cradle requirements pertaining to a particular pipe class, See sheet T-5.

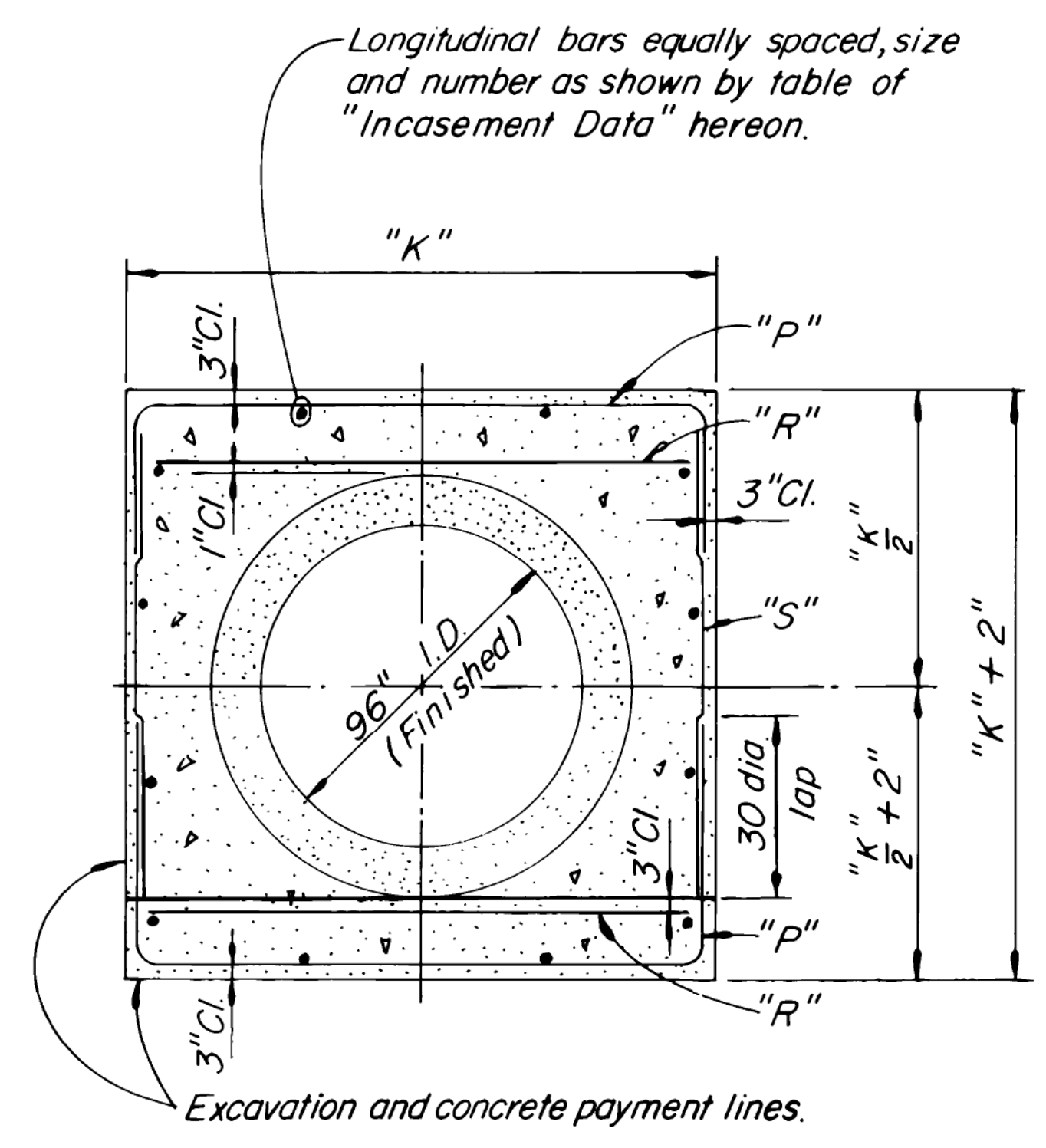
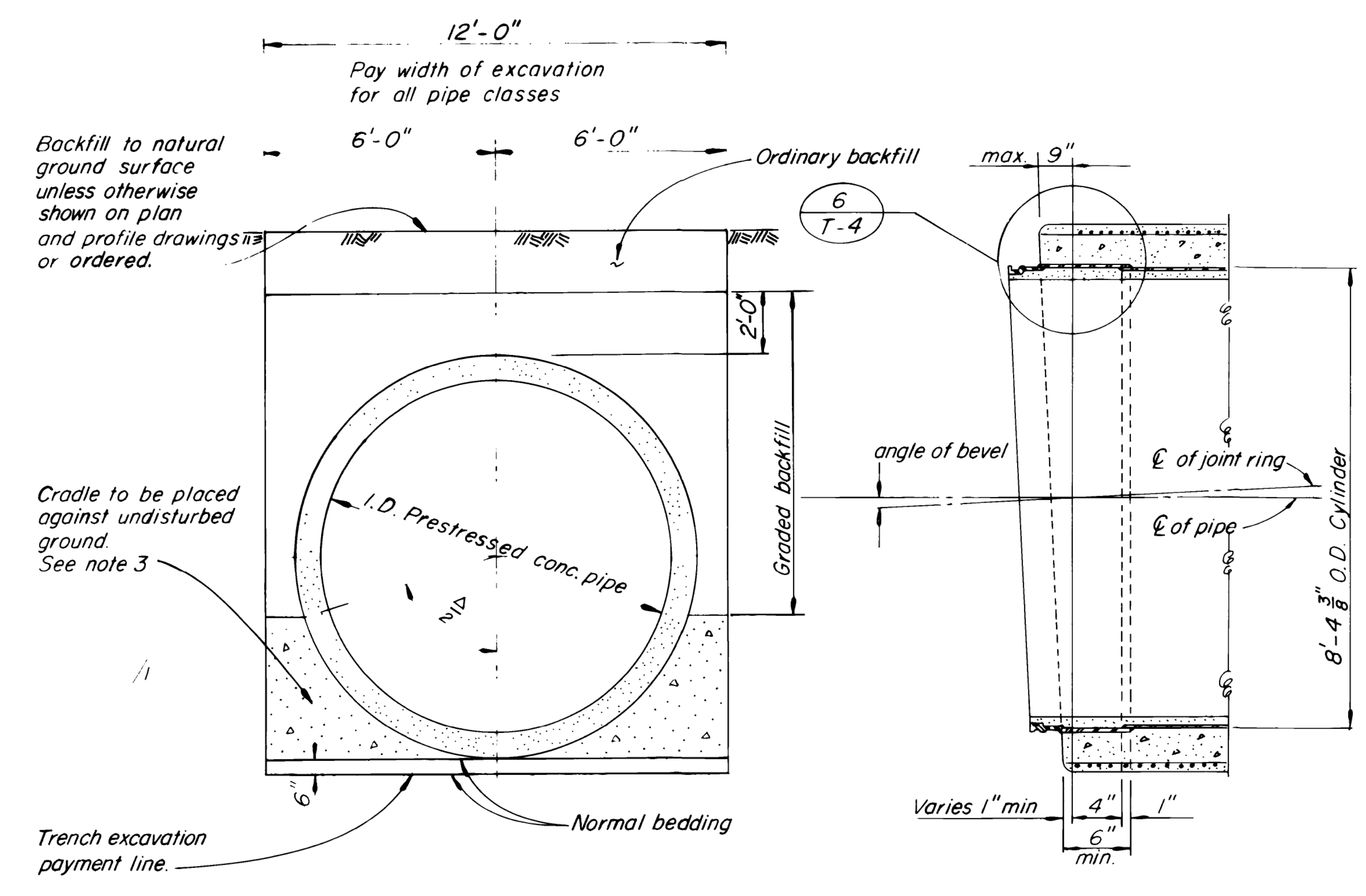

TYPE	MAX. COVER (FT)	"K"	LONGITUDINAL REINF.		TRANSVERSE REINF.		
			NO.	SIZE	"R" BARS	"S" BARS	"P" BARS
I	16	12'-0"	51	#9	#8@6	#7@6	#5@6
II	24	12'-2"	12	#6	#8@6	#7@6	#5@6
III	30	12'-6"	12	#6	#9@6	#8@6	#5@6
IV	16	12'-0"	12	#6	#8@6	#7@6	#5@6

REFERENCE DRAWINGS:
See Sheet T-1.

METROPOLITAN WATER DISTRICT ASSUMES NO RESPONSIBILITY FOR THE ACCURACY OF THE SUBSTRUCTURE INFORMATION HEREIN PROVIDED. THE USER ASSUMES RESPONSIBILITY FOR VERIFYING SUBSTRUCTURE LOCATION BEFORE EXCAVATING AND ASSUMES ALL LIABILITY FOR DAMAGE TO METROPOLITAN'S FACILITIES AS A RESULT OF SUCH EXCAVATION. CALL UNDERGROUND SERVICE ALERT AND THE RELEVANT REPRESENTATIVE FROM METROPOLITAN AT LEAST TWO DAYS BEFORE EXCAVATING IN PROXIMITY TO METROPOLITAN'S FACILITIES.

Constructed as shown - Completion Date: 8-10-70 w/lt
THE METROPOLITAN WATER DISTRICT
 OF SOUTHERN CALIFORNIA
 DISTRIBUTION SYSTEM
FOOTHILL FEEDER - RIALTO PIPELINE
 PRESTRESSED CONCRETE PIPE
 FABRICATION, INCASEMENT, EXCAVATION
 DETAILS

DESIGNED *AS*
 DRAWN *OB*
 CHECKED *AS*
 RECOMMENDED *AS*
 APPROVED *AS*

NO.	DATE	DWN.	CKD.	REVISION	REC.	APP.
Δ	5-7-69	C.S.S.	AJ	Changed cradle data per T-5		

WORK ORDER NO. 5-3682
 LOS ANGELES, APRIL 1969
 B-56457

REVISION CO-ORDINATION CHECK	
ORIGINAL	
RELEASE	
MECH.	
STRUCT.	
ELEC.	
CIVIL	
INTER-SECTION CO-ORDINATION CHECK	

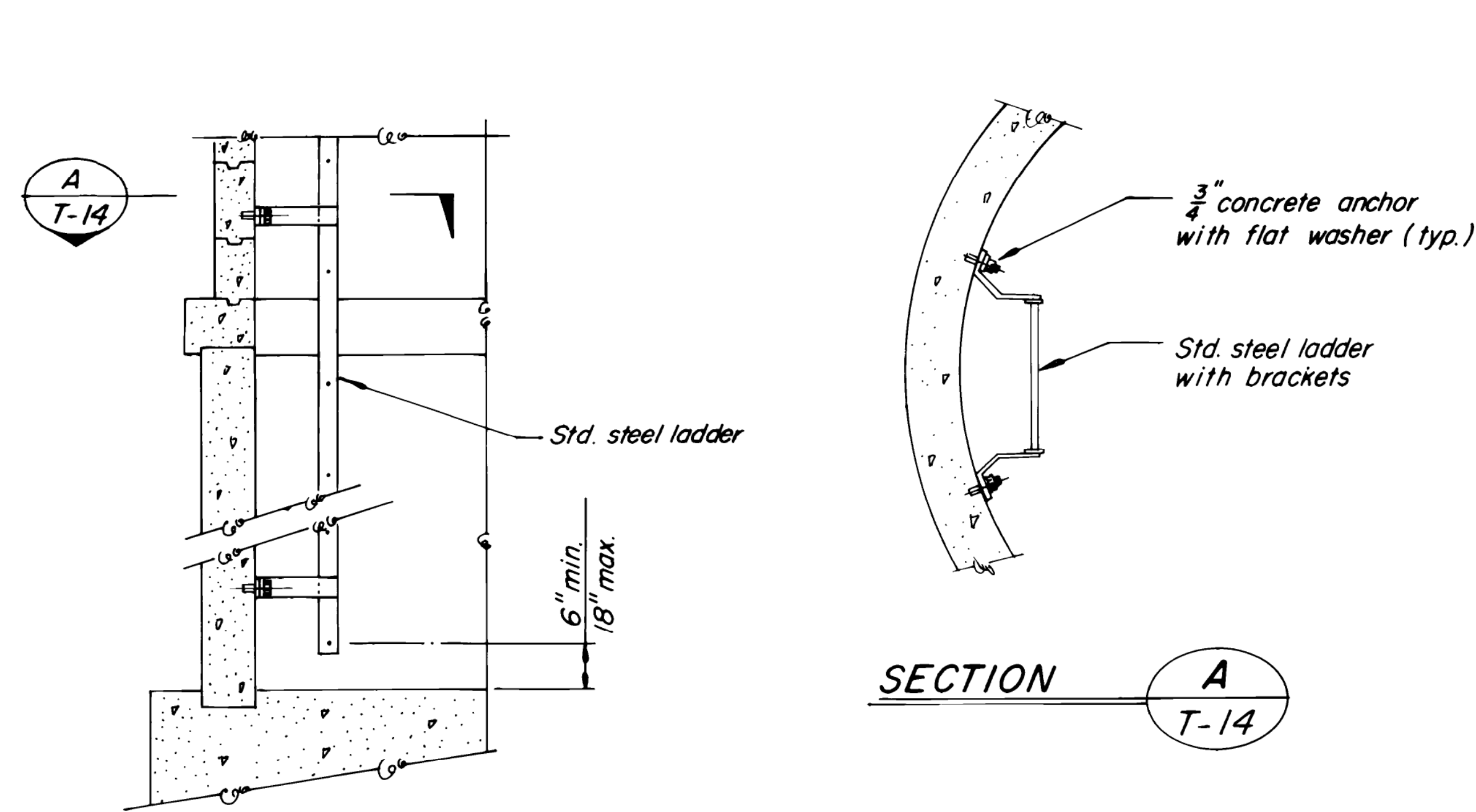

TYPICAL LADDER INSTALLATION

DETAIL 1 T-14

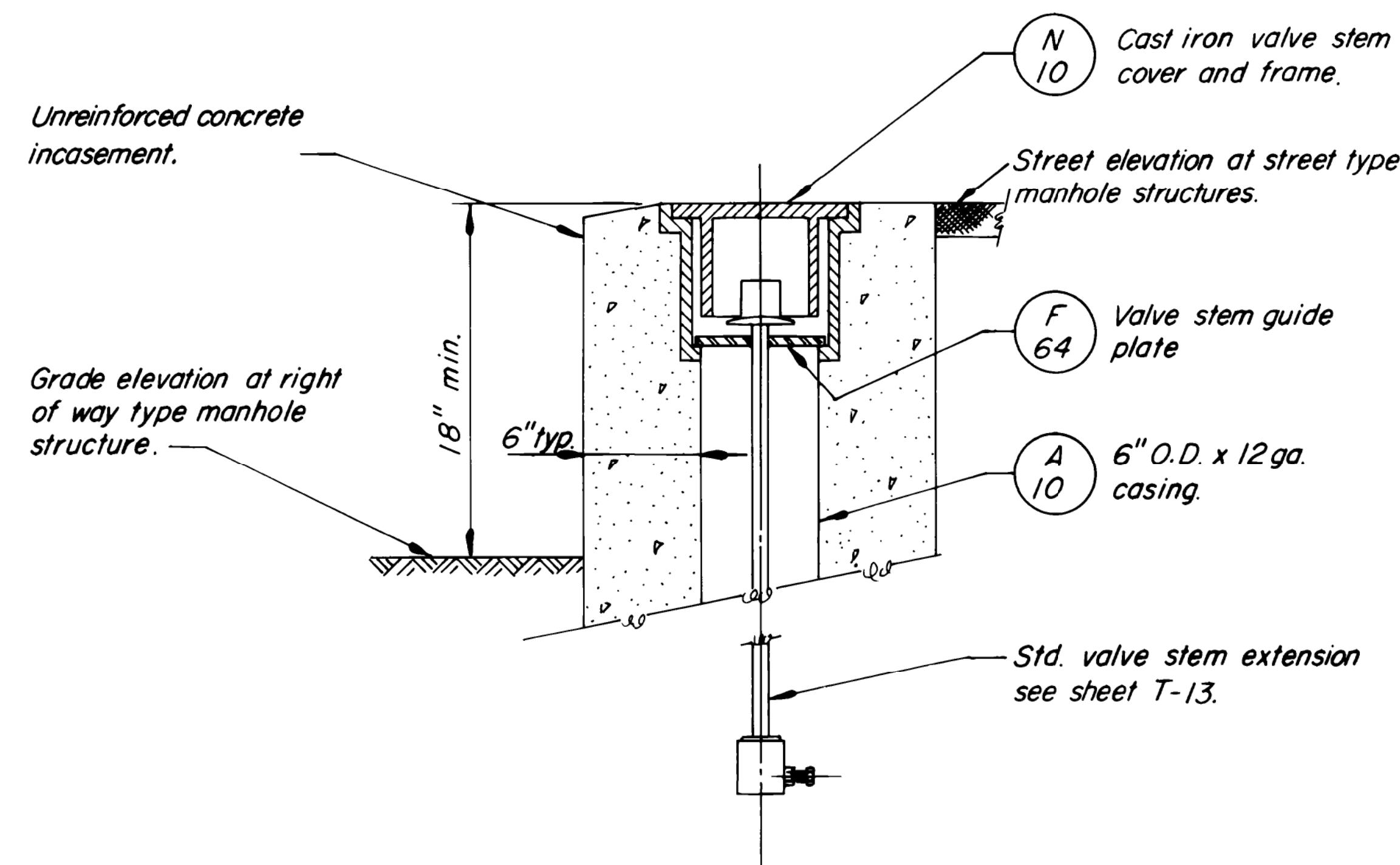

TYPICAL VALVE STEM INSTALLATION AT GRADE OR STREET ELEVATION

DETAIL 2 T-14

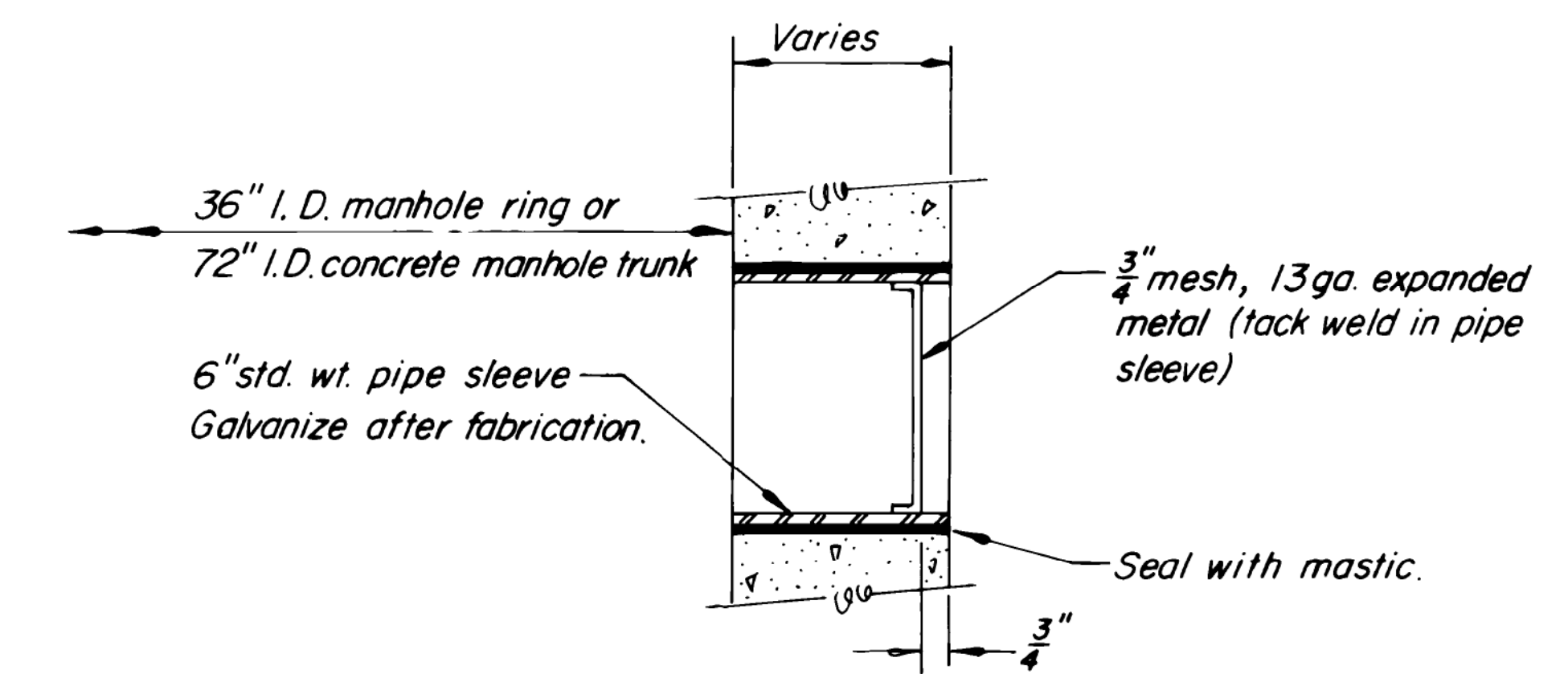

TYPICAL SCREENED PIPE SLEEVE INSTALLATION

SECTION C T-14

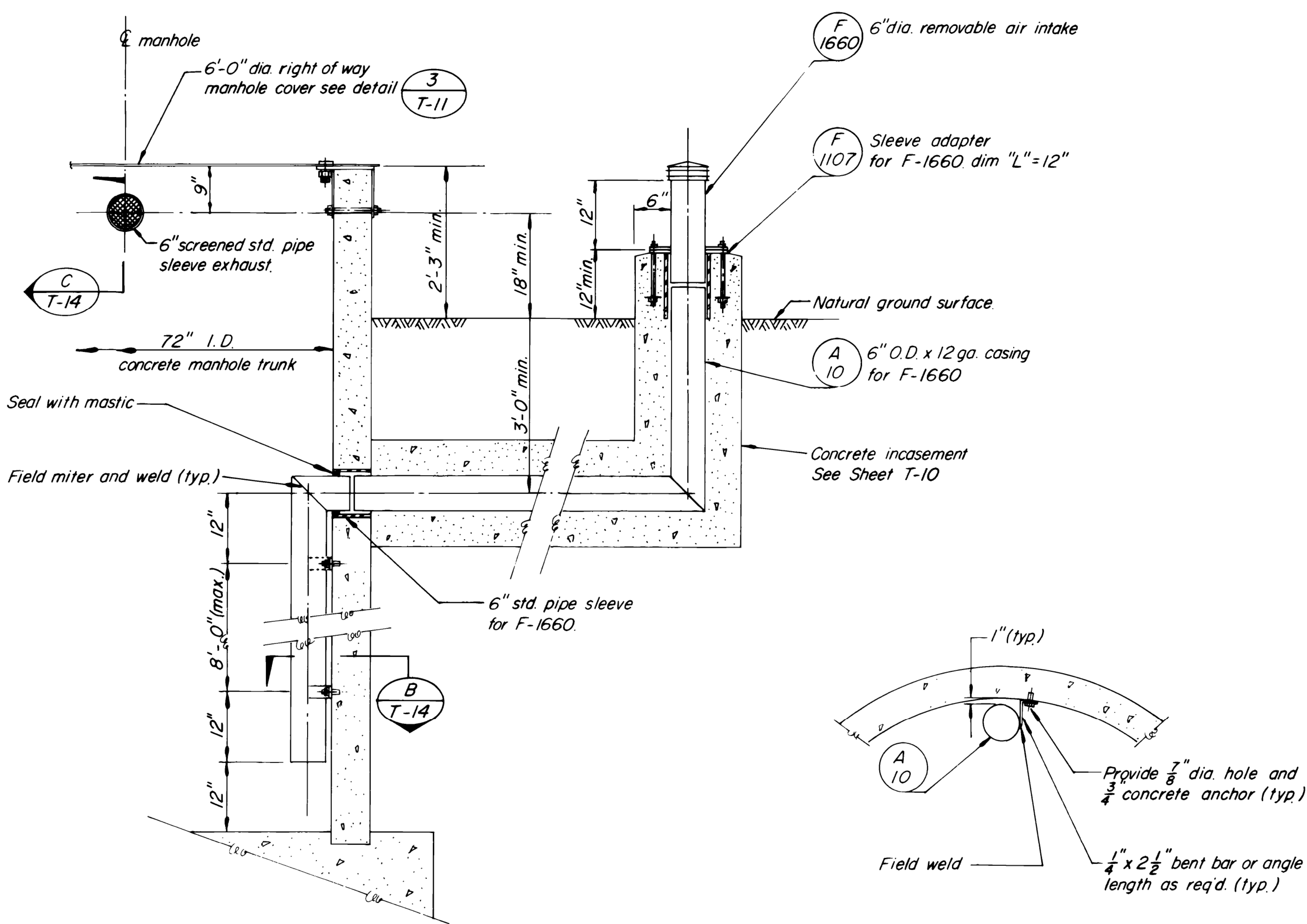

TYPICAL VENTILATION INSTALLATION FOR 6\"/>

DETAIL 3 T-14

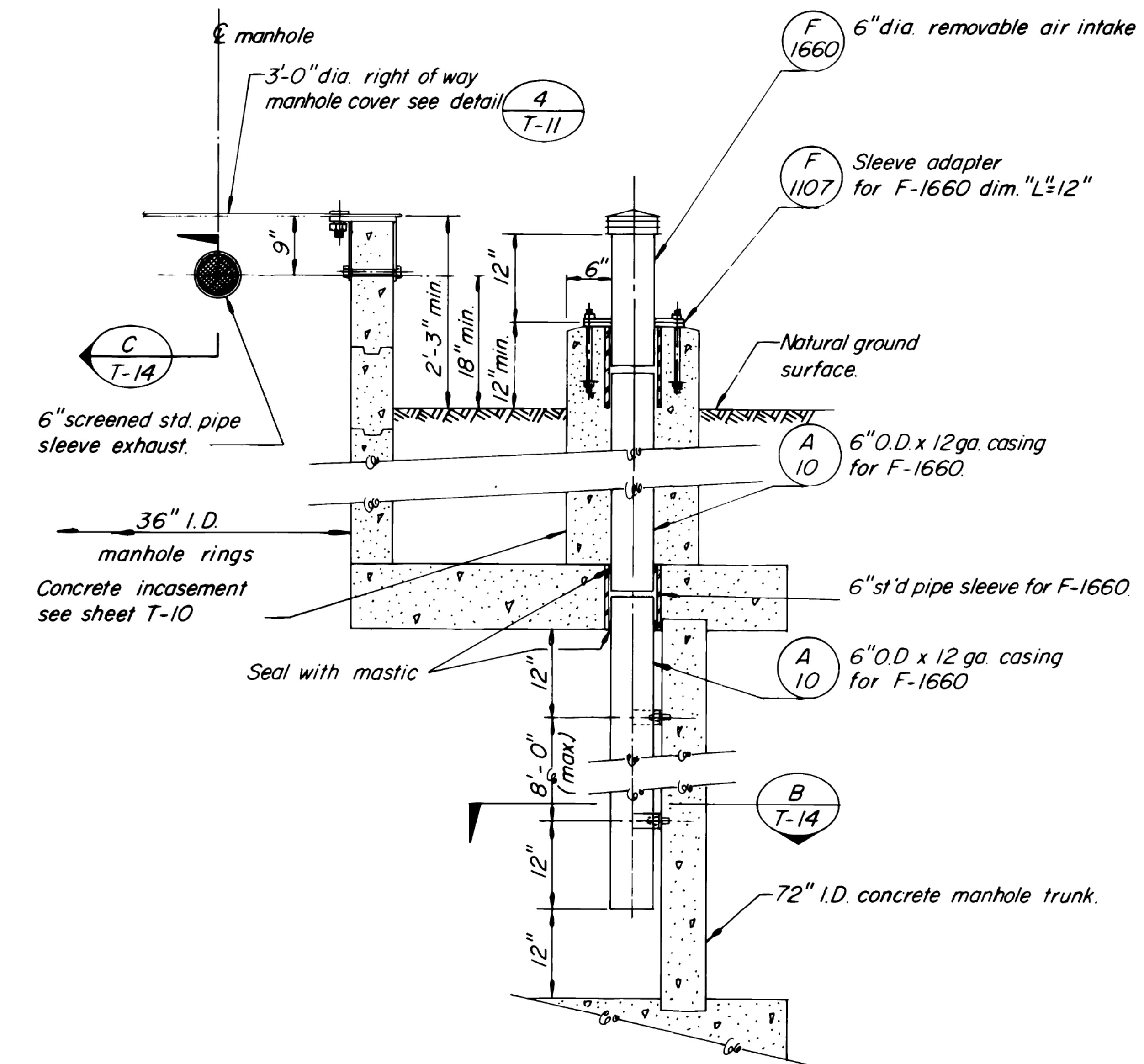

TYPICAL VENTILATION INSTALLATION FOR 3\"/>

DETAIL 4 T-14

REFERENCE DRAWINGS:
See sheet T-1.

METROPOLITAN WATER DISTRICT ASSUMES NO RESPONSIBILITY FOR THE ACCURACY OF THE SUBSTRUCTURE INFORMATION HEREIN PROVIDED. THE USER ASSUMES RESPONSIBILITY FOR VERIFYING SUBSTRUCTURE LOCATION BEFORE EXCAVATING AND ASSUMES ALL LIABILITY FOR DAMAGE TO METROPOLITAN'S FACILITIES AS A RESULT OF SUCH EXCAVATION. CALL UNDERGROUND SERVICE ALERT AND THE RELEVANT REPRESENTATIVE FROM METROPOLITAN AT LEAST TWO DAYS BEFORE EXCAVATING IN PROXIMITY TO METROPOLITAN'S FACILITIES.



REVISION CO-ORDINATION CHECK	
ORIGINAL	
MECH. STRUCT. ELEC. CIVIL	
INTER-SECTION CO-ORDINATION CHECK	

NO.	DATE	DWN.	CKD.	REVISION	REC.	APP.

Constructed as shown-Completion Date: 8-18-70 u.m.c.

THE METROPOLITAN WATER DISTRICT OF SOUTHERN CALIFORNIA
DISTRIBUTION SYSTEM

FOOTHILL FEEDER - RIALTO PIPELINE
TYPICAL INSTALLATION DETAILS FOR MANHOLE STRUCTURES

DESIGNED: *[Signature]*
DRAWN: G.G.S.
CHECKED: *[Signature]*

RECOMMENDED: *[Signature]*
APPROVED: *[Signature]*

WORK ORDER NO. 5-3682
LOS ANGELES, APRIL 1969
B-56467

Rialto Pipeline

ExpressWest Extension from Apple Valley to Rancho Cucamonga

- Fee Property
- Manhole Structure
- Pipeline
- Project Area
- Station #

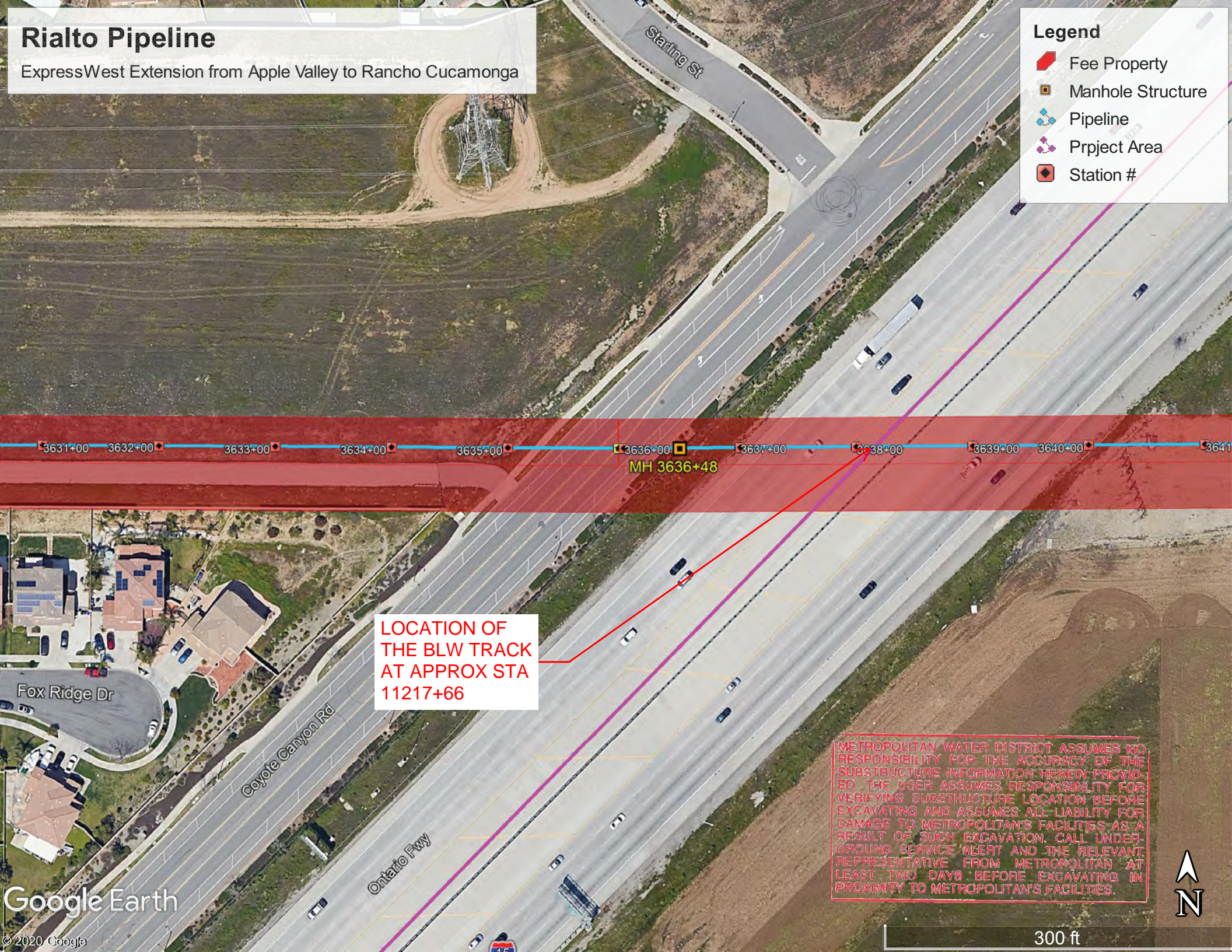

LOCATION OF THE BLW TRACK AT APPROX STA 11217+66

METROPOLITAN WATER DISTRICT ASSUMES NO RESPONSIBILITY FOR THE ACCURACY OF THE SUBSTRUCTURE INFORMATION HEREIN PROVIDED. THE USER ASSUMES RESPONSIBILITY FOR VERIFYING SUBSTRUCTURE LOCATION BEFORE EXCAVATING AND ASSUMES ALL LIABILITY FOR DAMAGE TO METROPOLITAN'S FACILITIES AS A RESULT OF SUCH EXCAVATION. CALL UNDERGROUND SERVICE ALERT AND THE RELEVANT REPRESENTATIVE FROM METROPOLITAN AT LEAST TWO DAYS BEFORE EXCAVATING IN PROXIMITY TO METROPOLITAN'S FACILITIES.



MWD_96in CROSSING TRACK Sta 11217+66

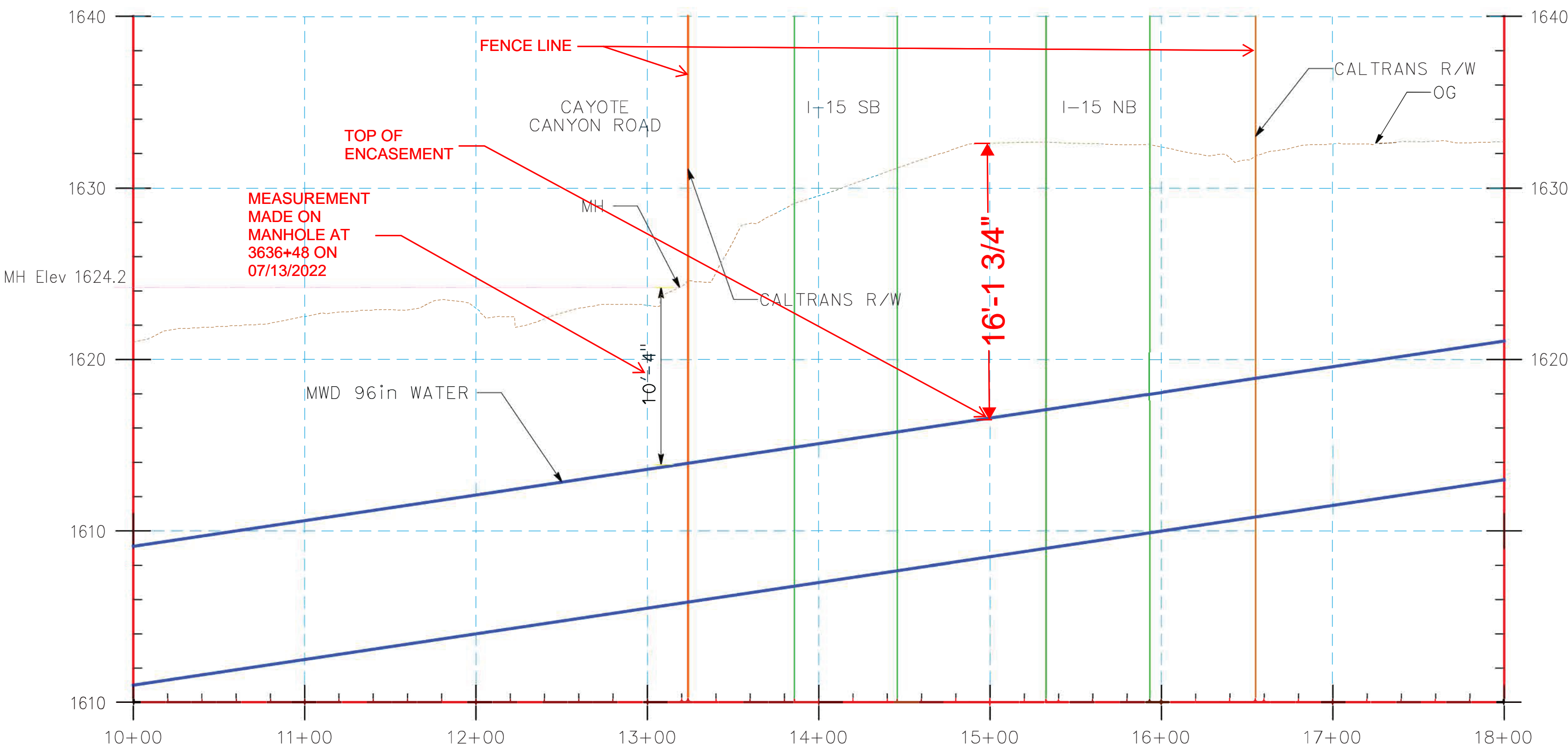

MH Elev 1624.2

MEASUREMENT
MADE ON
MANHOLE AT
3636+48 ON
07/13/2022

TOP OF
ENCASEMENT

FENCE LINE

CAYOTE
CANYON ROAD

MH

I-15 SB

I-15 NB

CALTRANS R/W

OG

CALTRANS R/W

MWD 96in WATER

10'-4"

16'-1 3/4"

LINE	SURFACE	OFFSET
—	XW_Priority7	0.00
—	XW_Priority71	0.00

Scaled 10.0000 Times Ver.
Scaled 1.0000 Times Hor.



THE METROPOLITAN WATER DISTRICT
OF SOUTHERN CALIFORNIA

Office of the General Manager

MWD Rialto Pipeline
Sta. 3634+00 to 3649+50
MWD Etiwanda Emergency
Discharge Conduit
Sta. 40+00 to 52+00
MWD Upper Feeder
Sta. 1133+00 to 1218+00
Substr. Job No. 4045-20-014

November 20, 2020

Ms. Mahsa Sheykhsoltan, EIT
Engineer
HNTB Corporation
601 West 5th Street
9th Floor
Los Angeles, CA 90071
msheykhsoltan@HNTB.com

Dear Ms. Sheykhsoltan:

Brightline West High-Speed Rail - Apple Valley to Rancho Cucamonga

Thank you for your email dated October 26, 2020, submitting a copy of meeting minutes for the meeting held on October 22, 2020, and pages of railroad loading information for your proposed Brightline West Extension project along the Interstate 15 Freeway (I-15) starting from 2,700 feet west of the Rancho Cucamonga Metrolink station and ending at Dale Evans Parkway in the town of Apple Valley.

In our previous letter dated September 28, 2020, we sent copies of our plans and rights-of-way for Rialto Pipeline and Etiwanda Emergency Discharge Conduit. We are sending copies of the easement language for our fee right-of-way in parcels 1606-24-5, 1606-24-9, and 1606-24-11 for your information and use.

As shown on the enclosed map, Metropolitan's 152-inch-inside diameter precast concrete Upper Feeder pipeline, manhole structures, air release structure, blow off structure, and 40-foot wide permanent easement right-of-way is located near your proposed project site generally along 8th Street.

Ms. Mahsa Sheykhsoltan
Page 2
November 20, 2020

We request that our facilities and rights-of-way be fully shown and identified as Metropolitan's on your project plans and that prints of the preliminary plans be submitted for our review and written approval as they pertain to our facilities. We are transmitting a copy of our prints of our Drawings B-21323 through B-21330 and Right-of-Way Maps 1402-1 through 1402-5 for your information and use.

We have reviewed the submitted loading information, and our loading restrictions are as follows:

1. The section of Rialto Pipeline, between Sta. 3636+55.88 and Sta. 3640+46.73, supports Cooper E-60 Loading. However, preliminary plans must be submitted to Metropolitan for our review and written approval to ensure that the proposed rail configuration is acceptable.

Please note that our Rialto Pipeline between Sta. 3634+00 to Sta. 3636+55.88 and Sta. 3640+46.73 to Sta. 3649+50 can only accommodate AASHTO H-20 vehicular loading.

2. Our Upper Feeder pipeline in this area was not designed for AASHTO H-20 loading. A concrete protective slab is required for any vehicular crossing in order to distribute the loading over our pipeline.

We also request that a stipulation be added to your plans and/or specifications to notify Jesse Franco of our Water System Operations Team at (909) 392-7182 or cell (661) 468-5188, at least two working days prior to starting any work in the vicinity of our facilities.

For any further correspondence with Metropolitan relating to this project, please make reference to the Substructures Job Number shown in the upper right-hand corner of the first page of this letter. Should you require any additional information, please contact David Fong, telephone (213) 217-6094 or email dfong@mwdh2o.com.

Very truly yours,



Shoreh Zareh, P.E.
Manager, Substructures Team

DRF
DOC#: 4045-20-014b

Enclosures (28)

APPENDIX B



BRIGHTLINEWEST Design Firm:  HNTB	Facility: MWD WATERLINE		
	Component: MWD WATERLINE ENCASEMENT ANALYSES		
Subject/Description: MWD WATERLINE ENCASEMENT ANALYSES	Originator: Murali Hariharan	Date:07/18/2022	Page 1 of 20
Discipline: Structural/Geotechnical	Checked:	Date: 07/18/2022	Job. No.
Calculation No. :	Backchk:	Date:07/18/2022	75761

TABLE OF CONTENTS

1.0 TRANSVERSE ANALYSIS	2
2.0 LONGITUDINAL ANALYSES	12

BRIGHTLINEWEST Design Firm:  HNTB	Facility: MWD WATERLINE		
	Component: MWD WATERLINE ENCASEMENT ANALYSES		
Subject/Description: MWD WATERLINE ENCASEMENT ANALYSES	Originator: Murali Hariharan	Date:07/18/2022	Page 2 of 20
Discipline: Structural/Geotechnical	Checked:	Date: 07/18/2022	Job. No.
Calculation No. :	Backchk:	Date:07/18/2022	75761

1.0 TRANSVERSE ANALYSIS

The model has the following elements. The selfweight of the encasement is automatically included in the model.

1. Encasement – Modeled as 3000 psi concrete using shell elements. An Opening is modeled inside the encasement and this opening has a diameter of $96''+2*8.5'' = 113''$. From the as-built the pipe is an 10-325/350 with a 7.5'' concrete wall and 1.25'' mortar encasement of the prestressing strands. This produces a total wall thickness of 8.5''.
2. Springs KR– The model is supported by springs at the invert. These are compression only soil springs with a K value of 150 pci. This value is generally valid based on the site soils and our assessment of soil borings for nearby structures.

$$K_R = K \left[\frac{B+1}{2B} \right]^2$$

where: K_R = reduced subgrade modulus
K = unit subgrade modulus
B = foundation width (in feet)

$K_R = 150 [1+1/2*1]^2 = 150$ pci when B=1 (1' spring spacing)

The actual spring value is then = Spring = $(150 / 1000) \times 144 \times 12 = 259.2$ kips/cubic foot = 259.2 kips/ft for a 1' analysis slice x 1' spring spacing. The spring values do not matter as such since settlement assessments are not made from this model. But a spring is used to realistically model the deflection and stress profiles in the encasement.

3. Vertical load on the encasement – Total load is 16 ft of soil at 125 pcf, 6 inches of sub-ballast and 12'' ballast. The unit weight of the ballast and sub-ballast is 120 pcf per AREMA 2020 Part 2, Section 2, 2.2.3 (b).

This load is then = $16*0.125+1.5*0.12 = 2.18$ ksf soil load

The axle load from the train is distributed in Accordance with AREMA 2020 Part 2, Section 10 on Culverts. The load distribution through an embankment of subgrade is 2V:1H from the bottom of the tie. The ties for this project are 8.5 ft long Vossloh prestressed concrete ties.

BRIGHTLINEWEST Design Firm:  HNTB	Facility: MWD WATERLINE		
	Component: MWD WATERLINE ENCASEMENT ANALYSES		
Subject/Description: MWD WATERLINE ENCASEMENT ANALYSES	Originator: Murali Hariharan	Date: 07/18/2022	Page 3 of 20
Discipline: Structural/Geotechnical	Checked:	Date: 07/18/2022	Job. No.
Calculation No. :	Backchk:	Date: 07/18/2022	75761

The load distribution is as shown.

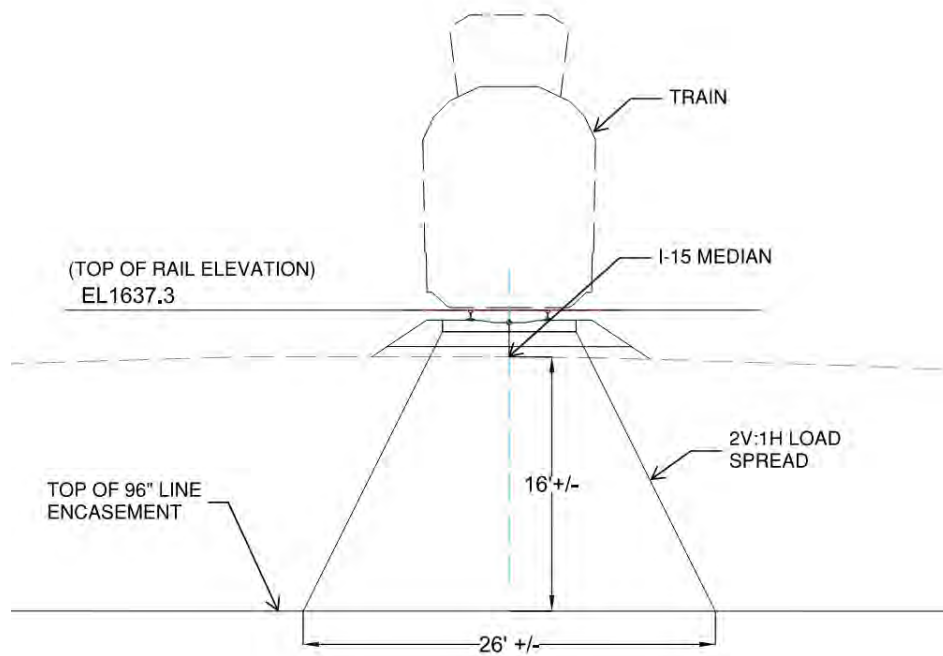

FIGURE 3: CROSS SECTION OF THE BLW TRACK

Total load on top of the MWD line is : $(3 \times 72.2) / (6.67 \times 26) = 1.24$ ksf
 No longitudinal load spread is assumed from the axles which is a conservative assumption.

Total load then for a 12"x12" spacing of nodes is $2.18 \text{ksf} \times 1 \times 1 + 1.24 \text{ksf} \times 1 \times 1 = 3.42$ kips per node.

There are no impact load factors below 10 ft.

The highway loads – 240 psf or two foot live load - is also present but wont additionally influence the zone that is loaded by the track load.

4. Lateral Load on the Encasement –

BRIGHTLINEWEST Design Firm:  HNTB	Facility: MWD WATERLINE		
	Component: MWD WATERLINE ENCASEMENT ANALYSES		
Subject/Description: MWD WATERLINE ENCASEMENT ANALYSES	Originator: Murali Hariharan	Date: 07/18/2022	Page 4 of 20
Discipline: Structural/Geotechnical	Checked:	Date: 07/18/2022	Job. No.
Calculation No. :	Backchk:	Date: 07/18/2022	75761

The height of the encasement is 12.5 feet and the axle spacing is 33.42 feet between the sets of 3 axles. The back set of axles then wont influence the line if the front set of over the line. The lateral load on the encasement is then based on K_o , the at-rest pressure of the soils.

The lateral pressure at the top is: $0.125 * 16 * 0.5 = 1 \text{ ksf}$

The lateral pressure at the bottom of the encasement is: $0.125 * (16 + 12.5) * 0.5 = 1.78 \text{ ksf}$

Use an average pressure of $(1 + 1.78) / 2 = 1.39 \text{ ksf}$ on the vertical sides of the encasement.

Total load then for a 12"x12" spacing of nodes is $1.39 * 1 * 1 = 1.39 \text{ kips per node}$.

With these elements the model is as shown:

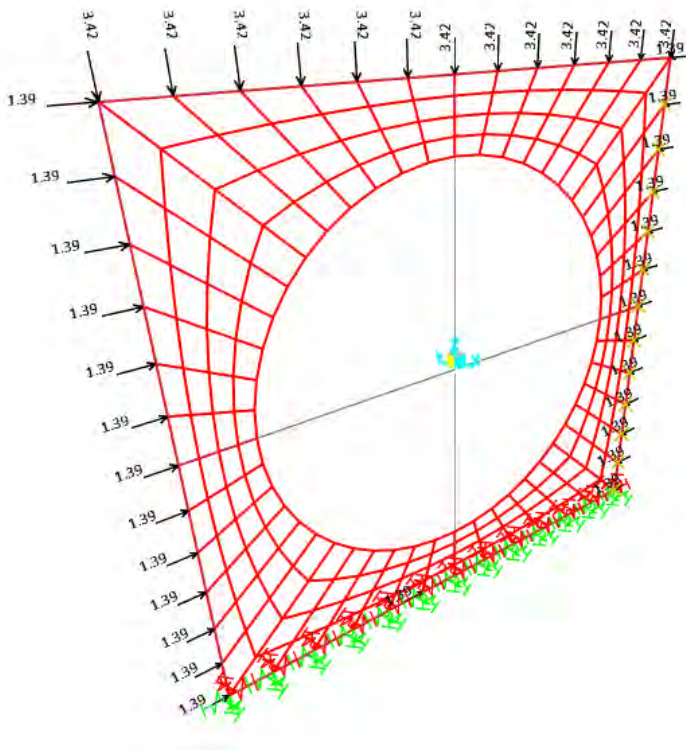

The primary force of interest is the bending moment at the crown and invert of the opening due to the vertical and lateral forces. The following shows the shell stresses in the horizontal direction. These are the bending stresses in the crown:

BRIGHTLINEWEST Design Firm:  HNTB	Facility: MWD WATERLINE		
	Component: MWD WATERLINE ENCASEMENT ANALYSES		
Subject/Description: MWD WATERLINE ENCASEMENT ANALYSES	Originator: Murali Hariharan	Date:07/18/2022	Page 5 of 20
Discipline: Structural/Geotechnical	Checked:	Date: 07/18/2022	Job. No.
Calculation No. :	Backchk:	Date:07/18/2022	75761

Maximum stresses are as expected. The top surface of the encasement is in compression and the bottom inside of the crown is in tension. To extract the bending moment, use the S11 stresses which are as shown:

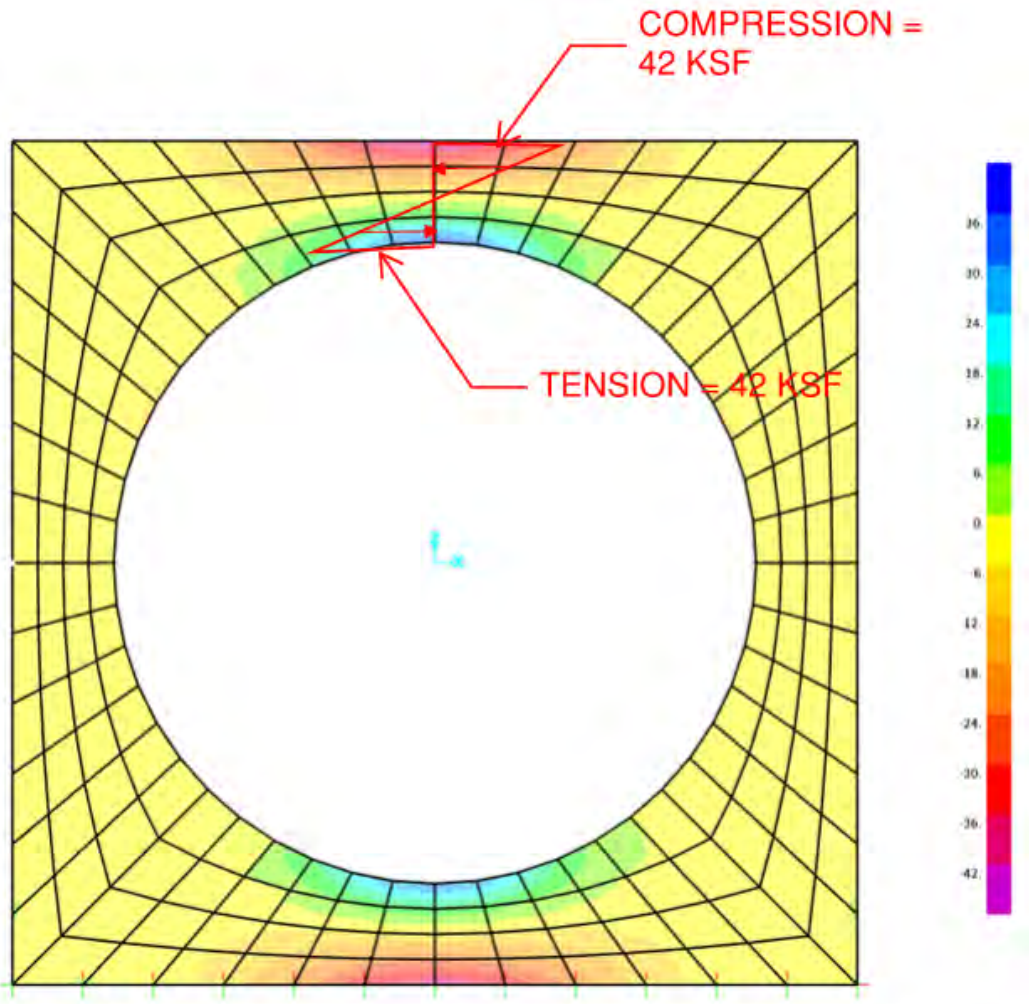

The bending moment that can be extracted is then as follows. The thickness of the encasement at the crown is approx. $[12.5*12-113]/2 = 18.5$ inches, say 18 inches.

$$M = [0.5*42*0.75]*[2/3*1.5] = 15.82 \text{ k-ft}$$

BRIGHTLINEWEST Design Firm:  HNTB	Facility: MWD WATERLINE		
	Component: MWD WATERLINE ENCASEMENT ANALYSES		
Subject/Description: MWD WATERLINE ENCASEMENT ANALYSES	Originator: Murali Hariharan	Date: 07/18/2022	Page 6 of 20
Discipline: Structural/Geotechnical	Checked:	Date: 07/18/2022	Job. No.
Calculation No. :	Backchk:	Date: 07/18/2022	75761

c. *Load Factor Design.*

(1) The group loading combinations for LOAD FACTOR DESIGN are as shown in [Table 8-2-5](#).

Table 8-2-5. Group Loading Combinations – Load Factor Design

Group	Item
I	1.4 (D + 5/3 (L + I) + CF + E + B + SF)
IA	1.8 (D + L + I + CF + E + B + SF)
II	1.4 (D + E + B + SF + W)
III	1.4 (D + L + I + CF + E + B + SF + 0.5W + WL + LF + F)
IV	1.4 (D + L + I + CF + E + B + SF + OF)
V	Group II + 1.4 (OF)
VI	Group III + 1.4 (OF)
VII	1.0 (D + E + B + EQ)
VIII	1.4 (D + L + I + E + B + SF + ICE)
IX	1.2 (D + E + B + SF + W + ICE)

AREMA has a load factor of 1.8 for earth pressures and live loads (GROUP 1A) or 1.4 for earth pressures and $1.4 \times 5/3 = 2.33$ for live load.

Use the maximum factor of 2.33.

Then the Bending Moment to be resisted = $2.33 \times 15.82 = 36.86$ k-ft.

Based on Drawing B56457, the Class 3 encasement has a reinforcement of #9 bars at 6" transverse Horizontal. The Moment capacity of the section is then:

CONCRETE DESIGN:

Bar-size (US)	Diameter in	Area in ²
#3	0.375	0.11
#4	0.5	0.2
#5	0.625	0.31
#6	0.75	0.44
#7	0.875	0.6

BRIGHTLINEWEST Design Firm:  HNTB	Facility: MWD WATERLINE		
	Component: MWD WATERLINE ENCASEMENT ANALYSES		
Subject/Description: MWD WATERLINE ENCASEMENT ANALYSES	Originator: Murali Hariharan	Date:07/18/2022	Page 7 of 20
Discipline: Structural/Geotechnical	Checked:	Date: 07/18/2022	Job. No.
Calculation No. :	Backchk:	Date:07/18/2022	75761

#8	1	0.79
#9	1.128	1
#10	1.27	1.27
#11	1.41	1.56
#14	1.693	2.25
#18	2.257	4

Tension Steel (At)

Bar Area **1**
No. of Bars **2.0**

Area in²

Cover

cov.t **4** in

Beam Size

b **12** in
D **18**
d in

Concrete and Steel Grades

f'c **3000** psi
fs **60000** psi

LRFD parameters

β (Reduce 0.05 for every 1000 psi over 4000 psi for concrete)

Compute Ultimate Moment Capacity

$$a = \frac{A_s f_y}{0.85 f'_c b} = \text{input } 3.92 \text{ in}$$

$$c = \frac{a}{\beta} = \text{input } 4.36 \text{ in}$$

$$\epsilon_s = 0.00664 \text{ Strain in steel}$$

BRIGHTLINEWEST Design Firm:  HNTB	Facility: MWD WATERLINE		
	Component: MWD WATERLINE ENCASEMENT ANALYSES		
Subject/Description: MWD WATERLINE ENCASEMENT ANALYSES	Originator: Murali Hariharan	Date:07/18/2022	Page 8 of 20
Discipline: Structural/Geotechnical	Checked:	Date: 07/18/2022	Job. No.
Calculation No. :	Backchk:	Date:07/18/2022	75761

$$\phi = 0.900$$

$$\text{Mu} = \phi [\text{As fy (d-a/2)}] = 1300235.294 \text{ lb-in}$$

$$= 108.35 \text{ k-ft}$$

Check Section

$$\text{Enter Factored Moment} = 36.86 \text{ k-ft}$$

$$\text{Factored Moment} = 36.86 \text{ k-ft} < 108.35 \text{ OK}$$

The section has more than adequate capacity to resist the BLW train loads in addition to the earth pressure loads.

BRIGHTLINEWEST Design Firm:  HNTB	Facility: MWD WATERLINE		
	Component: MWD WATERLINE ENCASEMENT ANALYSES		
Subject/Description: MWD WATERLINE ENCASEMENT ANALYSES	Originator: Murali Hariharan	Date: 07/18/2022	Page 9 of 20
Discipline: Structural/Geotechnical	Checked:	Date: 07/18/2022	Job. No.
Calculation No. :	Backchk:	Date: 07/18/2022	75761

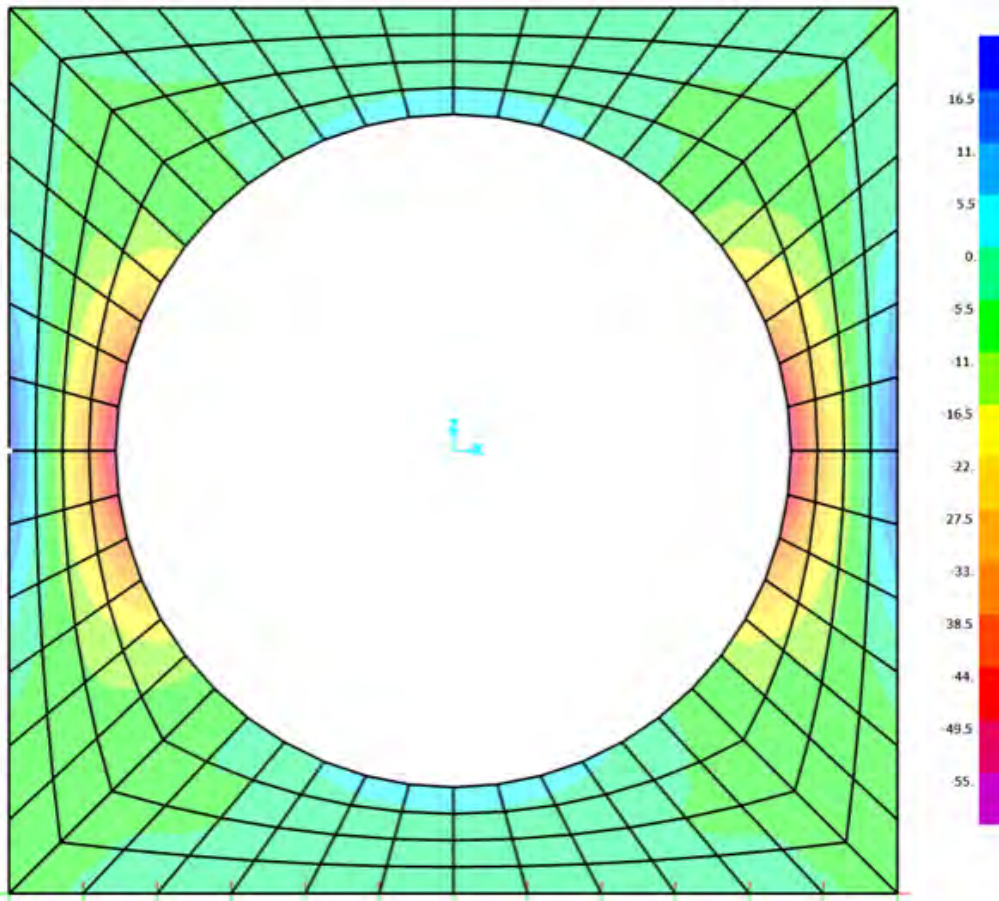

To extract the bending moment on the side walls, use the S22 stresses. Note that for the side walls, there is tension on the outside and compression on the inside. We also have thrust and bending forces.

$$P/A+M/Z = -55 \text{ ksf}$$

$$P/A-M/Z = 16.5 \text{ ksf}$$

$$\text{Then } 2M/Z = -55-16.5 = -71.5 \text{ ksf}$$

BRIGHTLINEWEST Design Firm:  HNTB	Facility: MWD WATERLINE		
	Component: MWD WATERLINE ENCASEMENT ANALYSES		
Subject/Description: MWD WATERLINE ENCASEMENT ANALYSES	Originator: Murali Hariharan	Date:07/18/2022	Page 10 of 20
Discipline: Structural/Geotechnical	Checked:	Date: 07/18/2022	Job. No.
Calculation No. :	Backchk:	Date:07/18/2022	75761

$$M/Z = -35.75 \text{ KSF}$$

$$M = -35.75 * \left[\left[\frac{1}{6} \right] * 1.5^2 * 1 \right] = 13.2 \text{ K-FT}$$

Use the same load factor of 2.33. Then the moment = 31.23 K-FT

The side wall outer reinf is #8 at 6". The Moment capacity is then:

CONCRETE DESIGN:

Bar-size (US)	Diameter in	Area in ²
#3	0.375	0.11
#4	0.5	0.2
#5	0.625	0.31
#6	0.75	0.44
#7	0.875	0.6
#8	1	0.79
#9	1.128	1
#10	1.27	1.27
#11	1.41	1.56
#14	1.693	2.25
#18	2.257	4

Tension Steel (At)

Bar Area **0.79**
No. of Bars **2.0**

Area **1.58** in²

Cover

cov.t **4** in

Beam Size

b **12** in
D **18**

BRIGHTLINEWEST Design Firm:  HNTB	Facility: MWD WATERLINE		
	Component: MWD WATERLINE ENCASEMENT ANALYSES		
Subject/Description: MWD WATERLINE ENCASEMENT ANALYSES	Originator: Murali Hariharan	Date: 07/18/2022	Page 11 of 20
Discipline: Structural/Geotechnical	Checked:	Date: 07/18/2022	Job. No.
Calculation No. :	Backchk:	Date: 07/18/2022	75761

d in

Concrete and Steel Grades

f'c psi
fs psi

LRFD parameters

β (Reduce 0.05 for every 1000 psi over 4000 psi for concrete)

Compute Ultimate Moment Capacity

$$a = \frac{A_s f_y}{0.85 f'_c b} = \text{ in}$$

$$c = \frac{a}{\beta} = \text{ in}$$

$$\epsilon_s = 0.00920 \text{ Strain in steel}$$

$$\phi = \text{$$

$$M_u = \phi [A_s f_y (d - a/2)] = \text{ lb-in}$$

$$= \text{ k-ft}$$

Check Section

Enter Factored Moment = k-ft

Factored Moment = k-ft < OK

The vertical reinf is also then more than adequate for the BLW track loads.

BRIGHTLINEWEST Design Firm:  HNTB	Facility: MWD WATERLINE		
	Component: MWD WATERLINE ENCASEMENT ANALYSES		
Subject/Description: MWD WATERLINE ENCASEMENT ANALYSES	Originator: Murali Hariharan	Date: 07/18/2022	Page 12 of 20
Discipline: Structural/Geotechnical	Checked:	Date: 07/18/2022	Job. No.
Calculation No. :	Backchk:	Date: 07/18/2022	75761

2.0 LONGITUDINAL ANALYSES

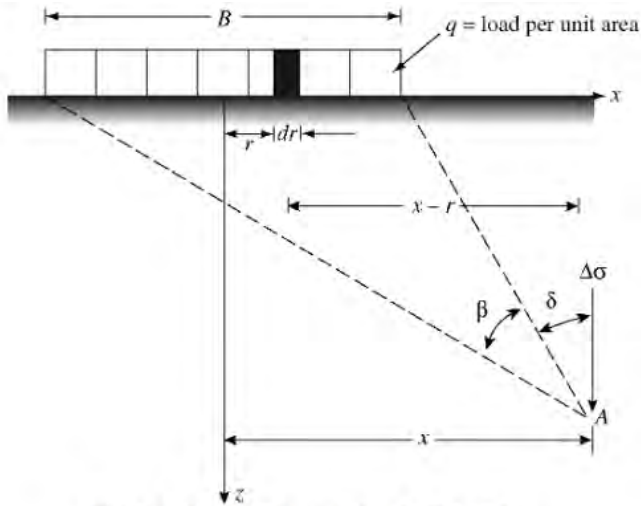

Flexible Strip Load over the Surface of a Semi-infinite Soil Mass
Figure 6.13. Das FGE (2005).

$$\Delta\sigma = \frac{q}{\pi} [\beta + \sin \beta \cos(\beta + 2\delta)]$$

Where:

- $\Delta\sigma$ = Change in Vertical Stress
- q = Load per Unit Area
- z = Depth
- x = Distance from Line Load

Angles measured in counter-clockwise direction are taken as positive

Use the Boussinesq equation to determine the stress increase at load center and 20 ft away.

The strip load is taken as:

$$q = (3 \times 72.2) / (6.67 \times 8.5) = 3.82 \text{ ksf}$$

Add the loads from 12 inch ballast and 6 inch sub-ballast. While the ballast and sub ballast load should be taken as a separate load, it is sufficiently accurate for the purposes of analyses since these loads are small in comparison to the track load.

$$\text{Total } q = 3.82 + 1.5 \times 0.12 = 4 \text{ ksf.}$$

With this as the load, and the above equations determine the settlement under the encasement for a thickness equal to 12.5 ft or "B" the width of the encasement. Therefore the settlement that is cumulated is from $16 + 12.5 = 28.5$ ft to $28.5 + 12.5 = 41$ ft.

In the spread sheet settlements are calculated at the midpoint of each 12" thick layer. The Boussinesq equation provides the stress and the stress divided by the Modulus of the soil (constrained modulus) is the strain. Strain times 12" is the settlement of each 12" layer under the encasement. The constrained modulus is assumed to be 500 ksf for the generally dense to

BRIGHTLINEWEST Design Firm:  HNTB	Facility: MWD WATERLINE		
	Component: MWD WATERLINE ENCASEMENT ANALYSES		
Subject/Description: MWD WATERLINE ENCASEMENT ANALYSES	Originator: Murali Hariharan	Date:07/18/2022	Page 13 of 20
Discipline: Structural/Geotechnical	Checked:	Date: 07/18/2022	Job. No.
Calculation No. :	Backchk:	Date:07/18/2022	75761

very dense sand gravels underlying the encasement. A typical compact Sand Gravel will have constrained moduli values in the 1500 to 3000 ksf range. This value is then conservative. The first layer for settlement assessment is from 28.5 ft to 29.5 ft. Approximate this as 28 to 29 ft. The mid point of this layer is then 28.5 ft. Approximate the last layer for settlement analysis as 41 to 42 ft or the mid point at 41.5 ft.

Distance from track Center to Footing Center

z ft	Es	B ft	q ksf	Angle	δ rad	β rad	$\Delta\sigma$ ksf	St - inch/12" layer	St - inch - Cumulative under the MWD encasement
0	500	8.5	4	1.57	-1.57	3.14	4.00203	0.09605	
0.5	500			1.45	-1.45	2.91	3.99931	0.09598	
1.5	500			1.23	-1.23	2.46	3.93720	0.09449	
2.5	500			1.04	-1.04	2.08	3.76074	0.09026	0.19057
3.5	500			0.88	-0.88	1.76	3.49705	0.08393	
4.5	500			0.76	-0.76	1.51	3.20005	0.07680	
5.5	500			0.66	-0.66	1.32	2.90884	0.06981	
6.5	500			0.58	-0.58	1.16	2.64231	0.06342	
7.5	500			0.52	-0.52	1.03	2.40632	0.05775	
8.5	500			0.46	-0.46	0.93	2.20038	0.05281	
9.5	500			0.42	-0.42	0.84	2.02147	0.04852	
10.5	500			0.38	-0.38	0.77	1.86596	0.04478	
11.5	500			0.35	-0.35	0.71	1.73033	0.04153	
12.5	500			0.33	-0.33	0.66	1.61148	0.03868	
13.5	500			0.30	-0.30	0.61	1.50680	0.03616	
14.5	500			0.29	-0.29	0.57	1.41410	0.03394	
15.5	500			0.27	-0.27	0.54	1.33156	0.03196	
16.5	500			0.25	-0.25	0.50	1.25770	0.03018	
17.5	500			0.24	-0.24	0.48	1.19128	0.02859	
18.5	500			0.23	-0.23	0.45	1.13127	0.02715	
19.5	500			0.21	-0.21	0.43	1.07684	0.02584	
20.5	500			0.20	-0.20	0.41	1.02725	0.02465	
21.5	500			0.20	-0.20	0.39	0.98191	0.02357	
22.5	500			0.19	-0.19	0.37	0.94031	0.02257	

BRIGHTLINEWEST Design Firm:  HNTB	Facility: MWD WATERLINE		
	Component: MWD WATERLINE ENCASEMENT ANALYSES		
Subject/Description: MWD WATERLINE ENCASEMENT ANALYSES	Originator: Murali Hariharan	Date:07/18/2022	Page 14 of 20
Discipline: Structural/Geotechnical	Checked:	Date: 07/18/2022	Job. No.
Calculation No. :	Backchk:	Date:07/18/2022	75761

23.5	500	0.18	-0.18	0.36	0.90201	0.02165
24.5	500	0.17	-0.17	0.34	0.86665	0.02080
25.5	500	0.17	-0.17	0.33	0.83391	0.02001
26.5	500	0.16	-0.16	0.32	0.80351	0.01928
27.5	500	0.15	-0.15	0.31	0.77522	0.01861
28.5	500	0.15	-0.15	0.30	0.74882	0.01797
29.5	500	0.14	-0.14	0.29	0.72413	0.01738
30.5	500	0.14	-0.14	0.28	0.70100	0.01682
31.5	500	0.13	-0.13	0.27	0.67928	0.01630
32.5	500	0.13	-0.13	0.26	0.65886	0.01581
33.5	500	0.13	-0.13	0.25	0.63961	0.01535
34.5	500	0.12	-0.12	0.25	0.62145	0.01491
35.5	500	0.12	-0.12	0.24	0.60427	0.01450
36.5	500	0.12	-0.12	0.23	0.58802	0.01411
37.5	500	0.11	-0.11	0.23	0.57261	0.01374
38.5	500	0.11	-0.11	0.22	0.55797	0.01339
39.5	500	0.11	-0.11	0.21	0.54407	0.01306
40.5	500	0.10	-0.10	0.21	0.53083	0.01274
41.5	500	0.10	-0.10	0.20	0.51822	0.01244

BRIGHTLINEWEST Design Firm:  HNTB	Facility: MWD WATERLINE		
	Component: MWD WATERLINE ENCASEMENT ANALYSES		
Subject/Description: MWD WATERLINE ENCASEMENT ANALYSES	Originator: Murali Hariharan	Date:07/18/2022	Page 15 of 20
Discipline: Structural/Geotechnical	Checked:	Date: 07/18/2022	Job. No.
Calculation No. :	Backchk:	Date:07/18/2022	75761

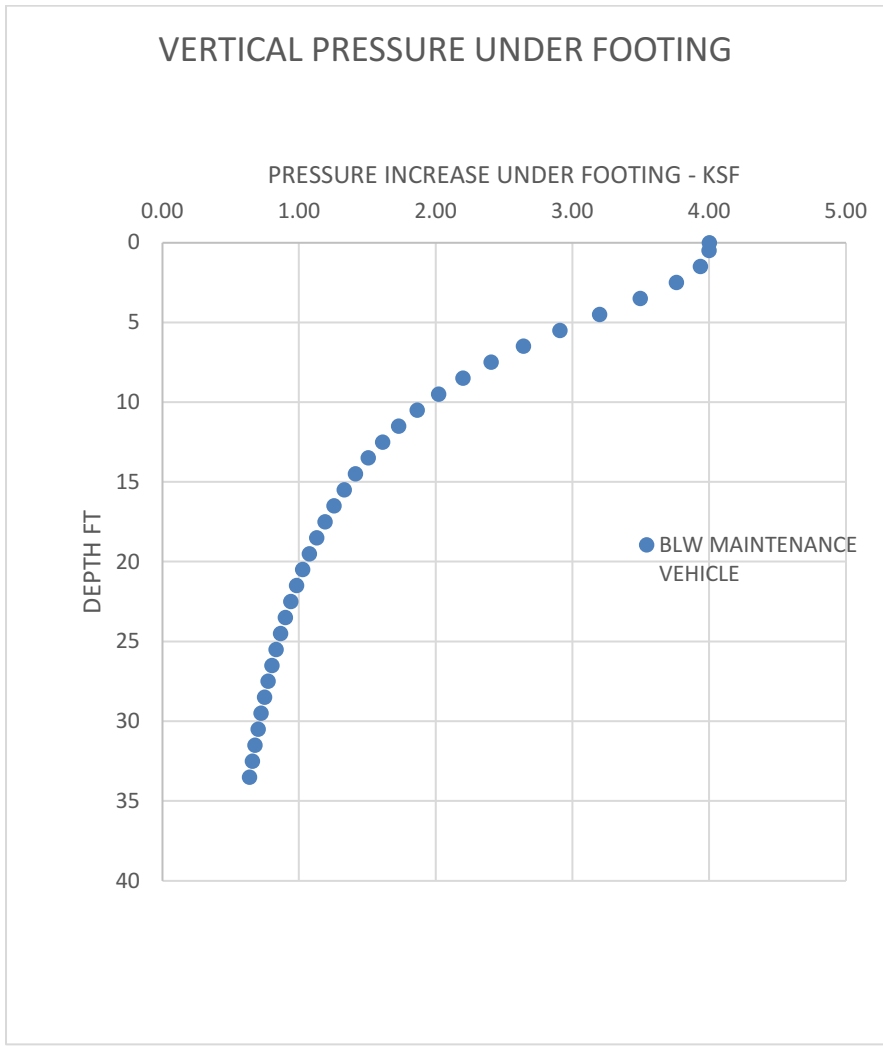

At a depth of 16.5 ft approx. 16 feet the vertical pressure is 1.26 ksf which compares well with the 2V:1H distribution assumed to encasement top.

Note also that at the depth of 41.5 ft or approx. B below the pipeline, the settlements are pretty small. And stress increase is approx 10% of applied load. The "B" used as cut off for settlement calculation is then adequate.

BRIGHTLINEWEST Design Firm:  HNTB	Facility: MWD WATERLINE		
	Component: MWD WATERLINE ENCASEMENT ANALYSES		
Subject/Description: MWD WATERLINE ENCASEMENT ANALYSES	Originator: Murali Hariharan	Date:07/18/2022	Page 16 of 20
Discipline: Structural/Geotechnical	Checked:	Date: 07/18/2022	Job. No.
Calculation No. :	Backchk:	Date:07/18/2022	75761

Distance from track Center to Footing Center

ft

20

z ft	Es	B ft	q ksf	Angle	δ rad	β rad	$\Delta\sigma$ ksf	St - inch/12" layer	St - inch - Cumulative under the MWD encasement
0	500	8.5	4	1.57	1.57	0.00	0.00000	0.00000	
0.5	500			1.55	1.54	0.01	0.00002	0.00000	
1.5	500			1.51	1.48	0.03	0.00053	0.00001	
2.5	500			1.47	1.41	0.05	0.00238	0.00006	0.10918
3.5	500			1.43	1.35	0.08	0.00630	0.00015	
4.5	500			1.39	1.29	0.09	0.01281	0.00031	
5.5	500			1.35	1.23	0.11	0.02216	0.00053	
6.5	500			1.31	1.18	0.13	0.03434	0.00082	
7.5	500			1.27	1.13	0.14	0.04915	0.00118	
8.5	500			1.23	1.08	0.16	0.06620	0.00159	
9.5	500			1.20	1.03	0.17	0.08501	0.00204	
10.5	500			1.16	0.98	0.18	0.10506	0.00252	
11.5	500			1.13	0.94	0.19	0.12582	0.00302	
12.5	500			1.09	0.90	0.19	0.14679	0.00352	
13.5	500			1.06	0.86	0.20	0.16755	0.00402	
14.5	500			1.03	0.83	0.21	0.18772	0.00451	
15.5	500			1.00	0.79	0.21	0.20703	0.00497	
16.5	500			0.97	0.76	0.21	0.22525	0.00541	
17.5	500			0.95	0.73	0.21	0.24224	0.00581	
18.5	500			0.92	0.71	0.21	0.25791	0.00619	
19.5	500			0.89	0.68	0.21	0.27219	0.00653	
20.5	500			0.87	0.66	0.21	0.28510	0.00684	
21.5	500			0.85	0.63	0.21	0.29664	0.00712	
22.5	500			0.82	0.61	0.21	0.30687	0.00736	
23.5	500			0.80	0.59	0.21	0.31583	0.00758	
24.5	500			0.78	0.57	0.21	0.32361	0.00777	
25.5	500			0.76	0.55	0.21	0.33027	0.00793	
26.5	500			0.74	0.54	0.20	0.33591	0.00806	
27.5	500			0.72	0.52	0.20	0.34059	0.00817	

BRIGHTLINEWEST Design Firm:  HNTB	Facility: MWD WATERLINE		
	Component: MWD WATERLINE ENCASEMENT ANALYSES		
Subject/Description: MWD WATERLINE ENCASEMENT ANALYSES	Originator: Murali Hariharan	Date:07/18/2022	Page 17 of 20
Discipline: Structural/Geotechnical	Checked:	Date: 07/18/2022	Job. No.
Calculation No. :	Backchk:	Date:07/18/2022	75761

28.5	500	0.71	0.50	0.20	0.34440	0.00827
29.5	500	0.69	0.49	0.20	0.34741	0.00834
30.5	500	0.67	0.48	0.20	0.34970	0.00839
31.5	500	0.66	0.46	0.19	0.35134	0.00843
32.5	500	0.64	0.45	0.19	0.35239	0.00846
33.5	500	0.63	0.44	0.19	0.35291	0.00847
34.5	500	0.61	0.43	0.18	0.35297	0.00847
35.5	500	0.60	0.42	0.18	0.35260	0.00846
36.5	500	0.59	0.41	0.18	0.35185	0.00844
37.5	500	0.57	0.40	0.18	0.35078	0.00842
38.5	500	0.56	0.39	0.17	0.34942	0.00839
39.5	500	0.55	0.38	0.17	0.34779	0.00835
40.5	500	0.54	0.37	0.17	0.34594	0.00830
41.5	500	0.53	0.36	0.17	0.34390	0.00825

BRIGHTLINEWEST Design Firm:  HNTB	Facility: MWD WATERLINE		
	Component: MWD WATERLINE ENCASEMENT ANALYSES		
Subject/Description: MWD WATERLINE ENCASEMENT ANALYSES	Originator: Murali Hariharan	Date:07/18/2022	Page 18 of 20
Discipline: Structural/Geotechnical	Checked:	Date: 07/18/2022	Job. No.
Calculation No. :	Backchk:	Date:07/18/2022	75761

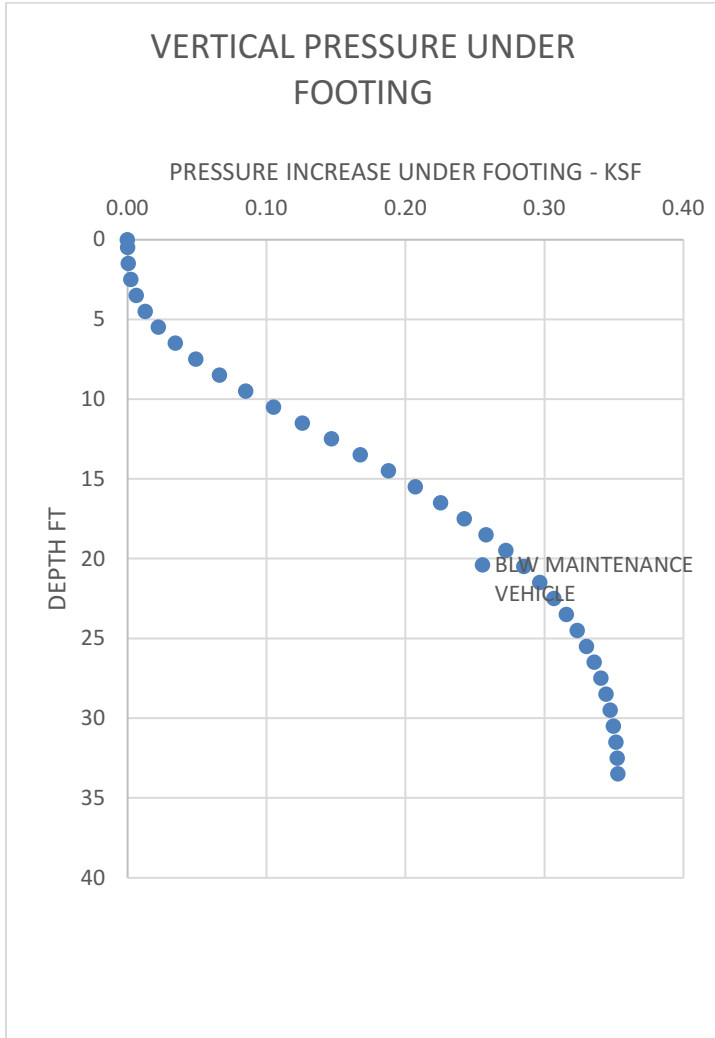

BRIGHTLINEWEST Design Firm:  HNTB	Facility: MWD WATERLINE		
	Component: MWD WATERLINE ENCASEMENT ANALYSES		
Subject/Description: MWD WATERLINE ENCASEMENT ANALYSES	Originator: Murali Hariharan	Date: 07/18/2022	Page 19 of 20
Discipline: Structural/Geotechnical	Checked:	Date: 07/18/2022	Job. No.
Calculation No. :	Backchk:	Date: 07/18/2022	75761

The deflection angle over a 20 ft pipe length is: tan inverse $[(0.19-0.10)"/240] = 0.0215$ degrees

DEFLECTION TABLE – E-301 STANDARD JOINT

Pipe Diameter (inches)	Joint Depth (inches)	Maximum Joint Opening (inches)	Maximum Deflection Angle (degrees)	Maximum Offset (inches)	Minimum Curve Radius (feet)	Average Laying Length (feet)
54 E-301	4-1/8	7/8	0.87	3-5/8	1325	20.03
60 E-301	4-1/4	1	0.90	3-3/4	1280	20.03
66 E-301	4-3/8	1-1/8	0.92	3-7/8	1250	20.04
72 E-301	4-1/2	1-1/4	0.94	3-15/16	1225	20.04
78 E-301	4-5/8	1-3/8	0.95	4	1205	20.04
84 E-301	4-3/4	1-1/2	0.97	4-1/16	1190	20.04
90 E-301	4-7/8	1-5/8	0.98	4-1/8	1175	20.05
96 E-301	4-7/8	1-5/8	0.92	3-7/8	1250	20.05
102 E-301	6	2-1/2	1.34	5-5/8	860	20.05
108 E-301	6	2-1/2	1.27	5-5/16	910	20.05
114 E-301	6	2-1/2	1.19	5	970	20.05
120 E-301	6	2-1/2	1.13	3-3/4	815	16.06
126 E-301	6	2-1/2	1.08	3-5/8	855	16.06
132 E-301	6	2-1/2	1.03	3-1/2	895	16.06
138 E-301	6	2-1/2	0.99	3-5/16	930	16.06
144 E-301	6	2-1/2	0.95	3-3/16	970	16.06

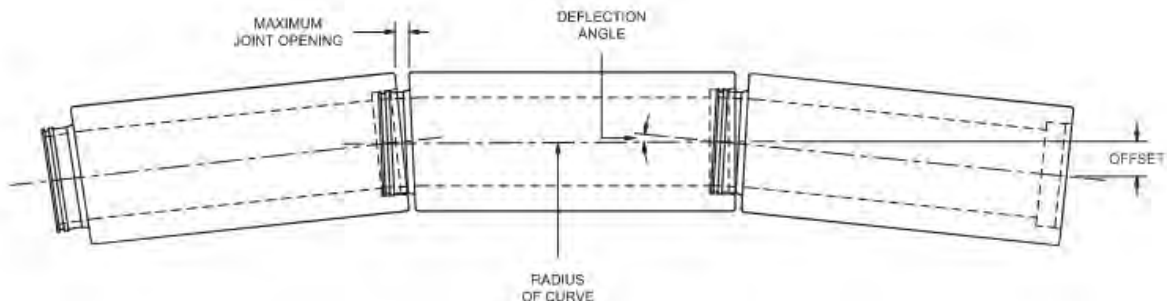

From the Prestressed Concrete Pressure Pipe Engineering Manual, 10th Edition. A Thompson Group Publication.

BRIGHTLINEWEST Design Firm:  HNTB	Facility: MWD WATERLINE		
	Component: MWD WATERLINE ENCASEMENT ANALYSES		
Subject/Description: MWD WATERLINE ENCASEMENT ANALYSES	Originator: Murali Hariharan	Date:07/18/2022	Page 20 of 20
Discipline: Structural/Geotechnical	Checked:	Date: 07/18/2022	Job. No.
Calculation No. :	Backchk:	Date:07/18/2022	75761

Assume that a further 0.5" joint opening is permitted beyond the opening at setting time or during construction. This half inch corresponds to $(0.5/1.625)*0.92 = 0.28$ degree > > 0.02 degree OK

DIST.	COUNTY	ROUTE	POST MILE-TOTAL PROJECT	SHEET NO.	TOTAL SHEETS
08	SBA	13	75/13.0	28	100

John W. Reynolds #165
 February 10, 1975

OPERATIONS

LEGEND OF BO

2 1/2" CORE PENETROMETER
 SAMPLER BORING (DRY)
 ROTARY BORING (WET)
 AUGER BORING (DRY)
 JET BORING
 CORE BORING
 TEST PIT

LEGEND OF EARTH MATERIALS

SILT CLAY
 CLAY
 SAND
 SILT
 CLAY
 SANDY CLAY
 SANDY SILT
 SILTY SAND
 SILTY CLAY
 SILTY SILT
 SILTY SAND

CONSISTENCY CLASSIFICATION FOR SOILS

Very loose
 Loose
 Slightly compact
 Medium dense
 Dense
 Very dense

CLASSIFICATION OF MATERIAL BASED ON STANDARD GRADE SIZE LIMITS

Gravel
 Sand
 Silt
 Clay

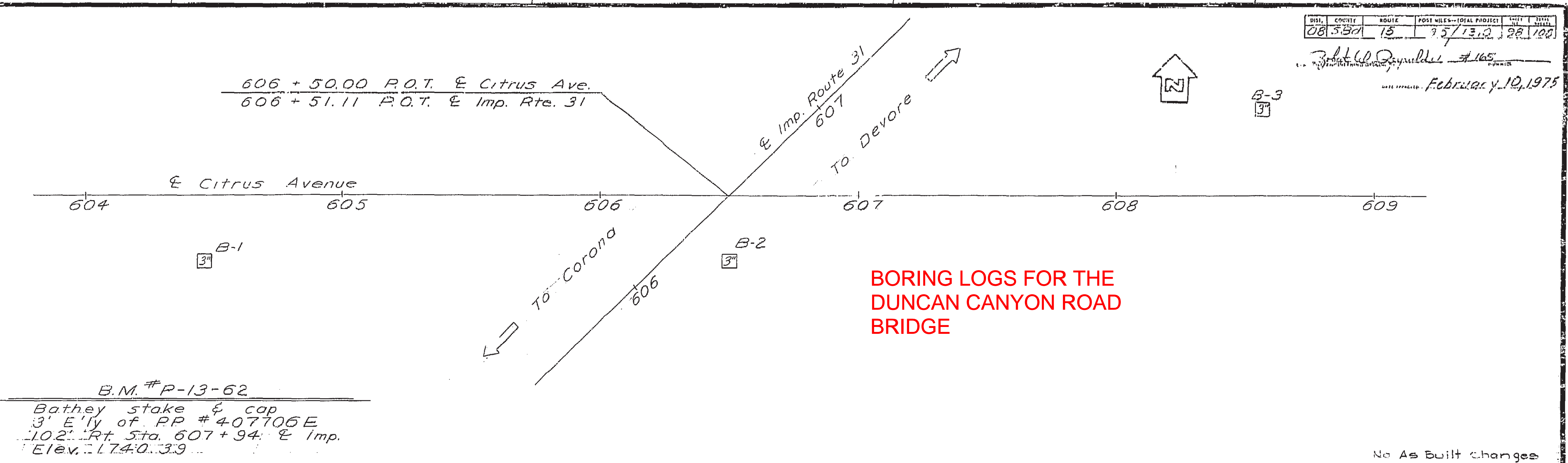

No As Built changes
AS BUILT
 CORRECTIONS BY J. Wheeler
 CONTRACT NO. 08-172104
 DATE 8/9/75

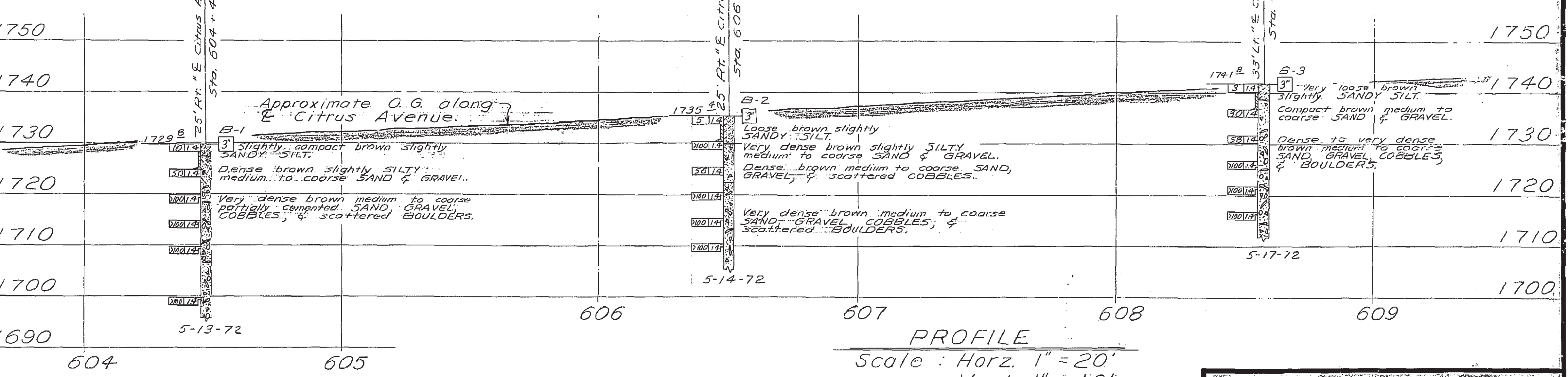

NO GROUND WATER ENCOUNTERED DURING THIS INVESTIGATION BY BRIDGE DEPT. GEOLOGY SECTION DATE 5-72

AS BUILT PLANS
 Contract No. 08-172104
 Date Completed _____
 Document No. 8000-3443

BRIDGE DEPARTMENT
 ENGINEERING GEOLOGY SECTION
 FIELD STUDY by R. FOX 5-72
 DRAWN by S. Kawamura 6-2-72
 CHECKED by R. FOX 6-19-72
 Approval Recommended by [Signature]
 Certified Engineering Geologist No. 165

STATE OF CALIFORNIA
 DEPARTMENT OF TRANSPORTATION

CITRUS AVENUE OVERCROSSING

LOG OF TEST BORINGS

BRIDGE NO. 54-980 POST MILE 11.0 DRAWING NO. SHEET 15 OF 15

REVISION DATES (PRELIMINARY STAGE ONLY)

I HEREBY CERTIFY THAT THIS IS A TRUE AND ACCURATE COPY OF THE ABOVE DOCUMENT TAKEN UNDER MY DIRECTION AND CONTROL ON THIS DATE IN SACRAMENTO, CALIFORNIA PURSUANT TO AUTHORIZATION BY THE DIRECTOR OF TRANSPORTATION.

DATE 10/1/76 [Signature]

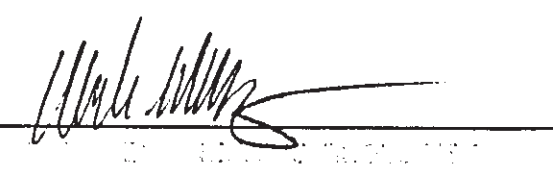
DIST	COUNTY	ROUTE	POST MILES TOTAL PROJECT	SHEET NO.	TOTAL SHEETS
08	Sbd	15,30	7.1/10.1, R10.0/R13.1	813	1184
 REGISTERED PROFESSIONAL ENGINEER M. DESALVATORE No. 39499 Exp. 12-31-97 CIVIL STATE OF CALIFORNIA					
8-4-97					
PLANS APPROVAL DATE					

THE STATE OF CALIFORNIA OR ITS OFFICERS OR AGENTS SHALL NOT BE RESPONSIBLE FOR THE ACCURACY OR COMPLETENESS OF ELECTRONIC COPIES OF THIS PLAN SHEET.

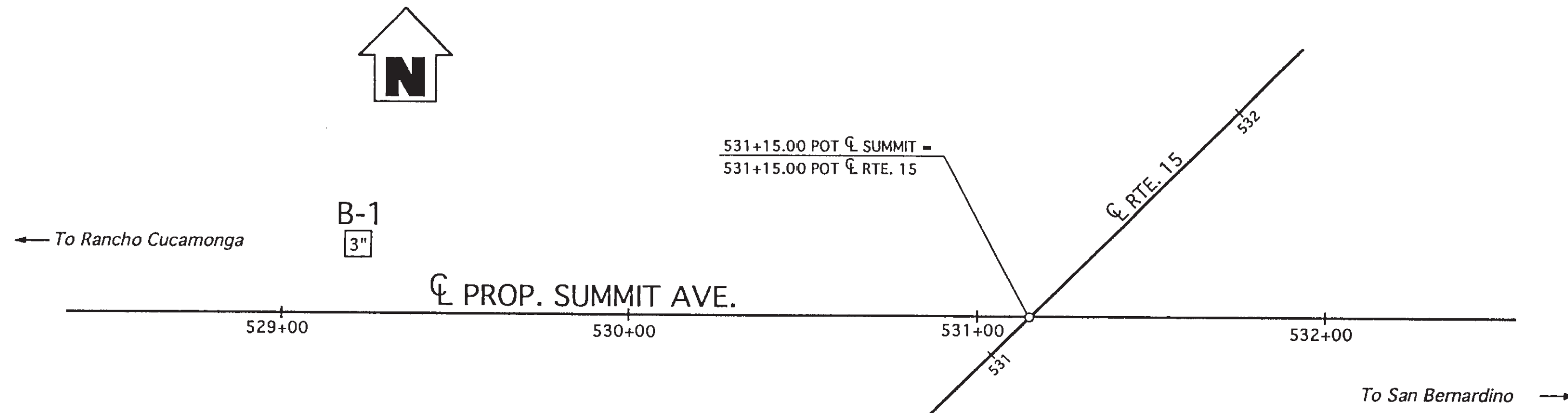

PLAN
1" = 30'

BORING LOGS FOR THE SUMMIT AVE OC BRIDGE

AS BUILT

CORRECTIONS BY Jose Corona
 CONTRACT NO. 08-20A304
 DATE 12-01-92 1-17-03
 NO CORRECTIONS THIS SHEET

BENCH MARK

BM #15-4-90 Elev. 1539.03'
 FD. AERIAL TARGET 89.02' RT. Q. RTE. 15, STA. 533+86.47.

- NOTES**
- NO GROUND WATER ENCOUNTERED DURING FIELD INVESTIGATION.
 - E = BLOW COUNT FOR ONE FOOT PENETRATION EXTRAPOLATED FROM BLOW COUNT FOR LESS THAN ONE FOOT (DUE TO CHANGE IN MATERIAL OR HARD DRIVING)

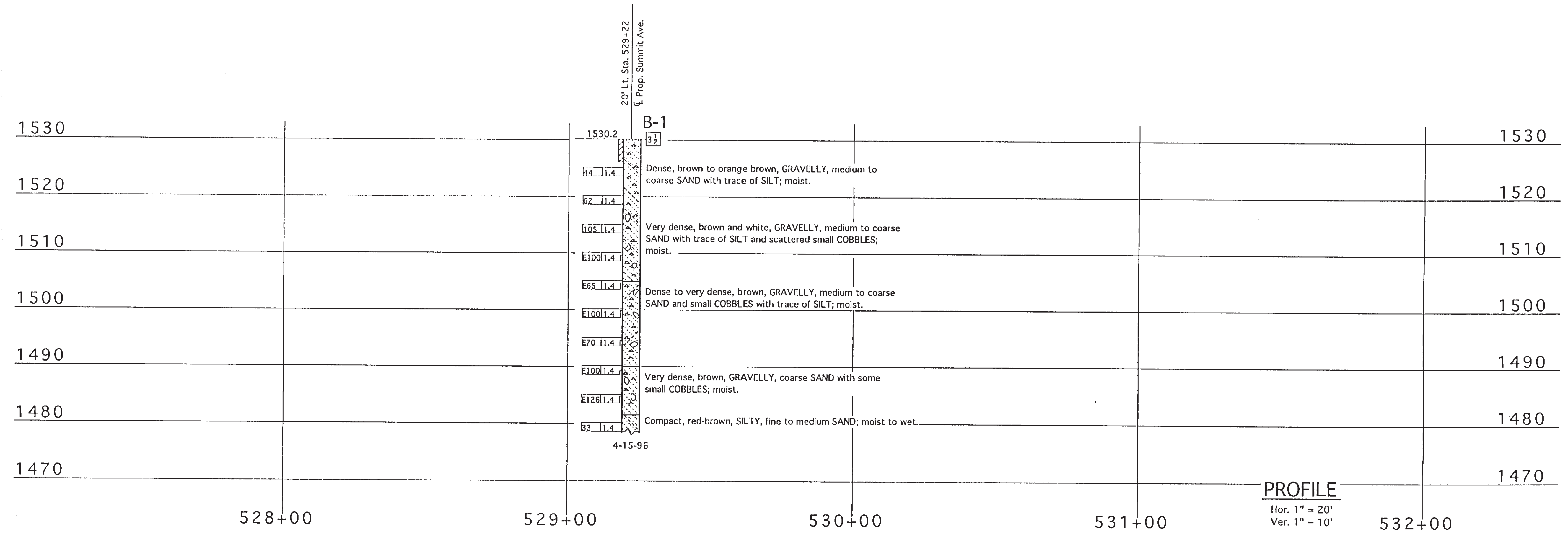

PROFILE

Hor. 1" = 20'
 Ver. 1" = 10'

LEGEND OF BORING OPERATIONS

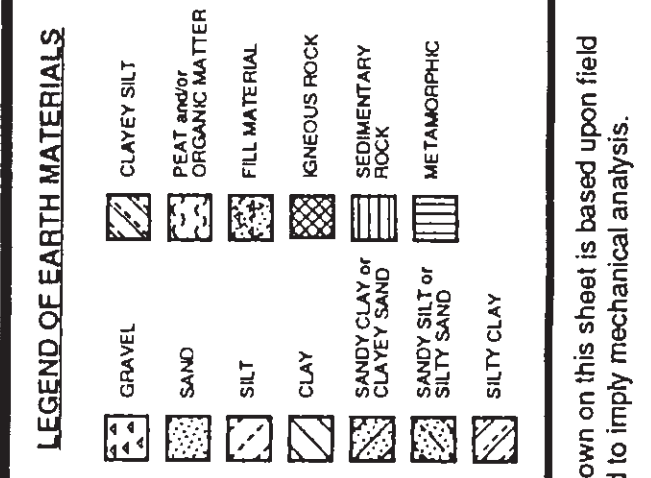
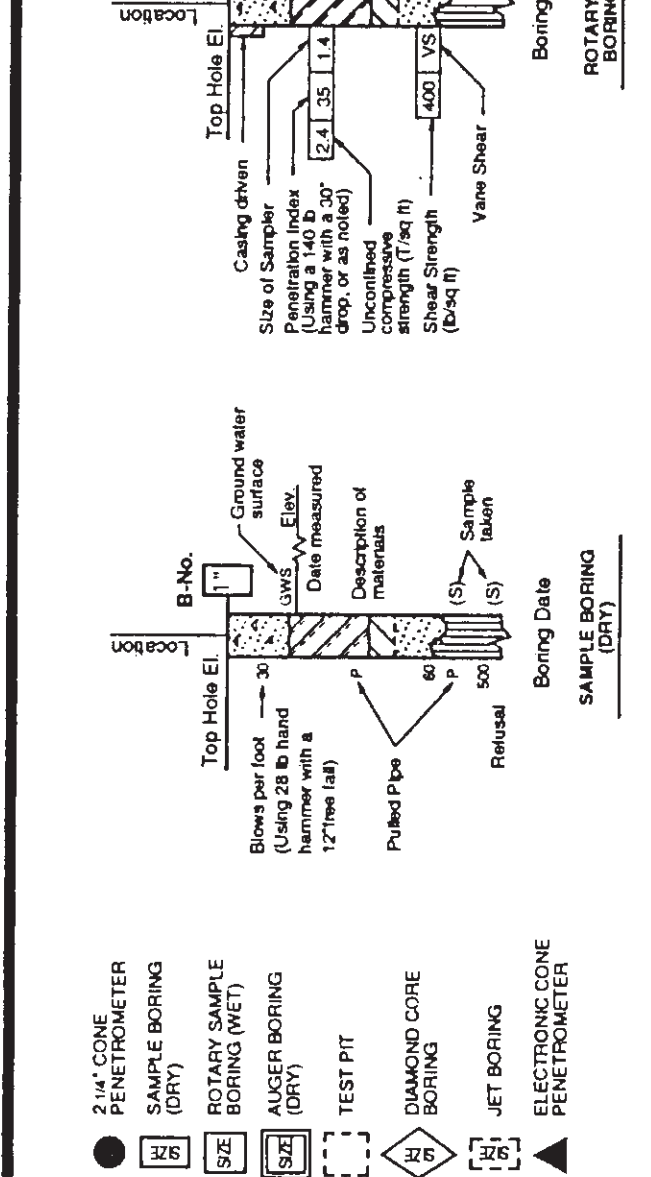

CONSISTENCY CLASSIFICATION FOR SOILS

According to the Standard Penetration Test

Penetration Index (Blows/Ft)	Cohesive	
	Granular	Very Soft Soft Slightly compact Compact Dense Very Dense
0-4	Very Loose	Very Soft
5-9	Loose	Soft
10-19	Slightly compact	Stiff
20-34	Compact	Very Stiff
35-59	Dense	Hard
>70	Very Dense	Very Hard

NOTE: Classification of earth material as shown on this sheet is based upon field inspection and is not to be construed to imply mechanical analysis.

ENGINEERING SERVICE CENTER	STRUCTURE FOUNDATIONS	FIELD INVESTIGATION BY: T. ALDERMAN	State of CALIFORNIA DEPARTMENT OF TRANSPORTATION	DIVISION OF STRUCTURES STRUCTURE DESIGN	BRIDGE NO. 54-0978	SUMMIT AVENUE OVERCROSSING LOG OF TEST BORINGS
DRAWN BY J. J. J. J.	5/96				POST MILE 9.6	

ORIGINAL SCALE IN INCHES FOR REDUCED PLANS → 0 1 2 3

CU: 08	DISREGARD PRINTS BEARING EARLIER REVISION DATES →	REVISION DATES (PRELIMINARY STAGE ONLY)	SHEET 18	OF 18
EA: 204301				

METROPOLITAN WATER DISTRICT OF SOUTHERN CALIFORNIA

Real Property Development and Management Group | 213-217-7750

APPLICATION for USE of REAL PROPERTY

Please complete all sections below.
Incomplete applications will result in delayed processing and responses.

Applicant Information

Company or Organization (if applicable)

DesertXpress Enterprises, LLC (dba "Brightline West")

Applicant Name

Adrian Share

E-mail address

ashare@brightlinewest.com

Street address

3920 W Hacienda Avenue

Street address line 2

City

Las Vegas

State

NV

Zip code

89118

Office Phone

407-496-5483

Cell Phone

Property Information

Address or Location (Include nearest cross streets if address is unavailable)

Interstate 15, Postemile SBD 10.274, 0.7 miles north of Beech Street Interchange, San Bernardino Co

Assessor Parcel Number(s)

1107261270000, 1107261280000, 1107261140000, 1107261180000

Type of Use or Operation

Construction of rail track within I-15 med

Duration of Use of Operation

30 days

Project / Use Description (if not applicable, mark with "n/a")

Type of facilities:

Track subgrade, ballast, and rails

Project specifications:

See attached MWD Water Line Analysis Memo

Construction or improvements:

Vehicles and equipment:

List and Quantity of Materials:

Project involves the following: (Mark all that apply)

- Engineering plans
- Soil studies
- CEQA compliance documentation

Project cost estimate

Environmental Impacts (if not applicable, indicate with "n/a")

Describe the likely environmental effects the proposed project will have on:

Air quality:

Visual impact:

Surface and groundwater quality and quantity:

Control or structural change on any stream or body of water:

Existing noise levels:

Land surface impacts:

Please include any additional comments or remarks that may be helpful in evaluating the request:

The existing MWD 96-inch water line is a prestressed concrete water line with an 8.5-inch thick wall and encased in concrete (MWD Class 3). A field measurement was obtained on 7/13/2022 indicating that the top of the encasement is 10'-4" beneath the at-grade manhole lid. The construction of the project is not anticipated to impact the existing water line or require any modifications to the line. Construction staging at this location will not occur within MWD property outside of the I-15 median. Details of the structural and geotechnical analyses are included in the attached MWD Water Line Analysis Memo.

**E-mail completed form and applicable documents to:
RealEstateServices@mwdh2o.com**

FOR INTERNAL USE ONLY:

Metropolitan Parcel Number(s):

Request Type:

Use:

Specific Use:

Rep Assigned:

W.A. Number

R.L. Number

Date Assigned:

Fong,David R

From: Beikae,Mohsen
Sent: Wednesday, October 12, 2022 8:58 AM
To: Fong,David R
Cc: Su,Bei
Subject: RE: High Speed Train
Attachments: High Speed Rail.pptx

Hi David,

Figure 1 shows the plan view of the track of the proposed High-Speed Train (HSP) and the alignment of the existing Rialto pipeline. Based on the figure, the HST is obliquely overcrossing the pipeline while inducing not only cyclic vertical and horizontal displacements but also twisting the affected reach of the pipeline alignment clockwise and counterclockwise in the horizontal plane. The cyclic deformations of the pipeline could be evaluated if a few seismographs were installed on the ground surface for example at the track, 20, 50, and 100 feet away from the track, as shown schematically in Figure 1, and recorded the ground motions while the HST crossing the seismographs. The measured ground acceleration/velocity/displacement time histories could be used to empirically estimate the pipeline deformations due to the HST overcrossing.

As such, please submit:

1. Available experimental studies/case histories providing the three components (two horizontal and one vertical) of the ground accelerations/velocity/displacement time histories at and adjacent to the HST track somewhere (e.g., California, Europe, Japan, etc.) having the same foundation conditions and using the same Siemens NOVO train with a maximum axle load of 38 kips with speed in the range of 125 to 155 miles per hour. The alignment of the array of seismographs, as presented in Figure 1, should be normal to the track in order to show the lateral attenuation of the Rayleigh waves with distance from the HST track. Note that the two horizontal components of each seismographs should be normal and parallel to the track. The measured ground acceleration/velocity/displacement time histories can be used to estimate the pipeline cyclic deformations and twisting due to the HST overcrossing.
1. The site-specific geotechnical report including, but not limited to, the shear wave velocity profile and shear strength of the foundation soil.

Thanks,

Mohsen Beikae

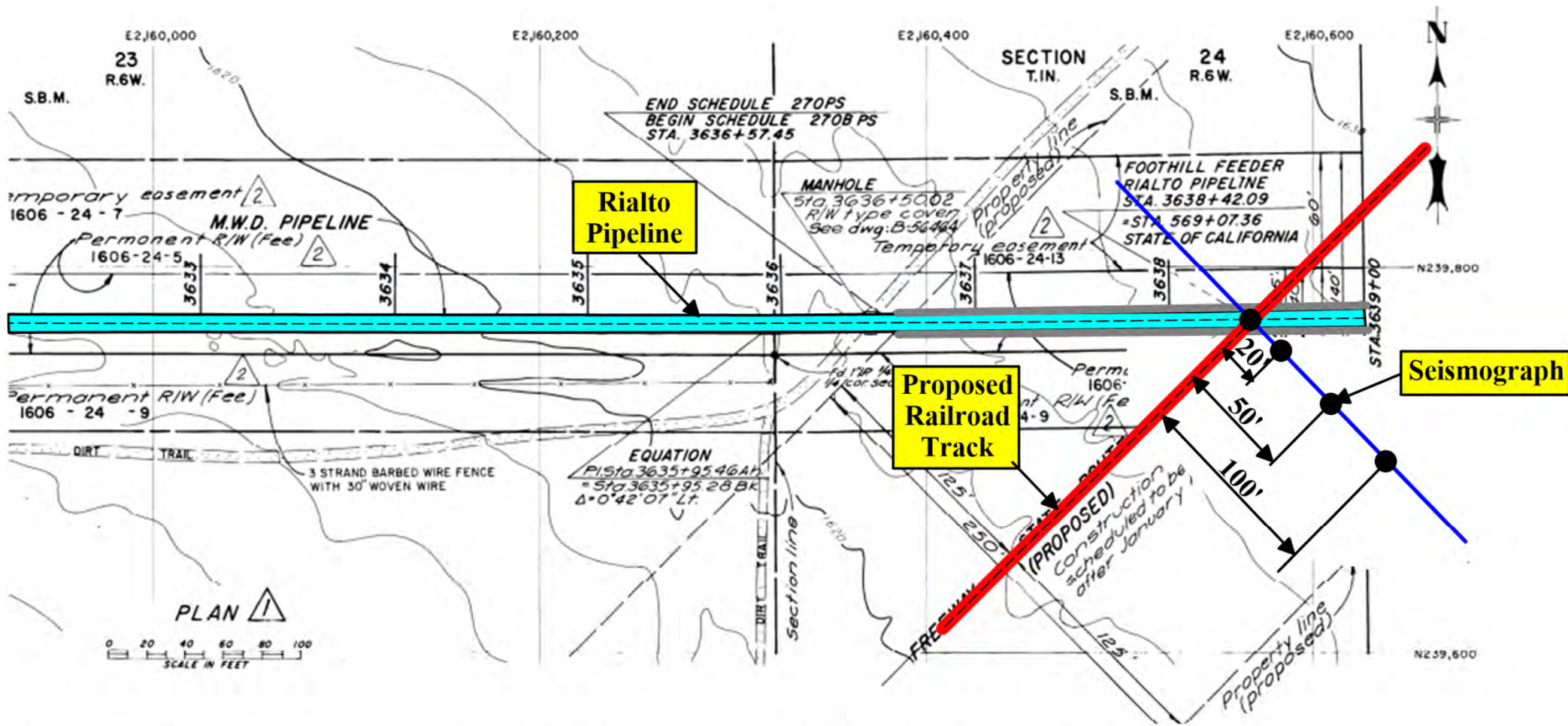

Figure 1 Showing Alignments of Rialto Pipeline/Proposed Railroad Track and Seismograph Locations

PUBLIC SUBMISSION

As of: November 29, 2022
Received: November 21, 2022
Status: Posted
Posted: November 22, 2022
Category: Decision / Response
Tracking No. lar-bfqh-6xla
Submission Type: Web

Docket: FRA-2022-0090

Brightline West Cajon Pass High-Speed Rail Project Environmental Assessment

Comment On: FRA-2022-0090-0001

Brightline West Cajon Pass Environmental Assessment -Final

Document: FRA-2022-0090-0013

Comment from Victor Valley Wastewater Reclamation Authority

Submitter Information

Email: dpoulsen@vwwra.com

Government Agency Type: Local

Government Agency: Victor Valley Wastewater Reclamation Authority

General Comment

As the General Manager for the Victor Valley Wastewater Reclamation Authority and a fifty plus year resident of the High Desert, I highly support the Brightline West extension. This is a critical transportation corridor that has become significantly congested with residents from our local area commuting for work. There are few alternatives to utilizing this corridor. Use of any other roads as an alternate to the normal Interstate 15 path through the Cajon pass causes traffic congestions on treacherous mountain roads detrimental to the environment and more dangerous for travelers. This rail line connection from the High Desert will offer our local residents the opportunity to travel to Ontario Airport, Downtown Los Angeles and other southern California destinations using a safe and environmentally friendly transportation method. The train will improve the quality of life for High Desert residents while simultaneously lessening vehicle carbon fuel emissions for cleaner air. The train station and supporting operations will bring more commerce and growth to the north part of the Victor Valley providing property and sales tax growth for our local governments to improve our local communities. The Brightline West Cajon Pass project has the potential to provide significant economic growth to our region while also lessening carbon emissions and improving air quality. We at VVWRA are striving to do our part to lessen green house gases and we strongly support this project on its environmental benefits and the economic benefits it will bring to our member agencies, the Town of Apple Valley, the City of Hesperia, the City of Victorville and surrounding San Bernardino County areas.

From: [Andrew Metzger](#)
To: [Krysten McCue](#)
Cc: [Audrey Zagazeta](#); [Scott Steinwert](#)
Subject: FW: Brightline West Cajon Pass High-Speed Rail Project Environmental Assessment
Date: Wednesday, December 14, 2022 1:26:12 PM
Attachments: [image001.png](#)
[image002.png](#)
[image003.png](#)
[image004.png](#)
[image005.png](#)
[image006.png](#)
[image007.png](#)

Here's the second one.

Andrew Metzger, Project Manager
Circlepoint | 200 Webster Street, Suite 200, Oakland, CA 94607
tel 408.715.1502 | mob 408.728.0828 | www.circlepoint.com



This message and its contents are confidential. If you received this message in error, do not use or rely upon it. Instead, please inform the sender and then delete it.

From: Mielke, Matthew (FRA) <Matthew.Mielke@dot.gov>
Sent: Wednesday, December 14, 2022 11:06 AM
To: Scott Steinwert <s.steinwert@circlepoint.com>; Andrew Metzger <a.metzger@circlepoint.com>
Cc: Audrey Zagazeta <a.zagazeta@circlepoint.com>
Subject: FW: Brightline West Cajon Pass High-Speed Rail Project Environmental Assessment

FYI

From: Jordan, Joseph - FS <joseph.jordan@usda.gov>
Sent: Wednesday, December 7, 2022 2:19 PM
To: Mielke, Matthew (FRA) <Matthew.Mielke@dot.gov>
Cc: Rechsteiner, Joseph -FS <joseph.rechsteiner@usda.gov>
Subject: Brightline West Cajon Pass High-Speed Rail Project Environmental Assessment

CAUTION: This email originated from outside of the Department of Transportation (DOT). Do not click on links or open attachments unless you recognize the sender and know the content is safe.

Hello Matthew,

I'm Joe Jordan, the district Wildlife biologist for the Front Country Ranger District on the San Bernardino NF. I was sent the link for the EA, but was unable to download the EA. Seeing that the project would take primarily in the median and the only comments that I have is that the under passings are used for wildlife crossings and there may be some TES wildlife species close to the project area. I would suggest that surveys are conducted in the area. Thank you and if you have any

questions, please let me know.

Joe Jordan



Joseph Jordan
District Wildlife Biologist
Forest Service
San Bernardino National Forest,
Front Country Ranger District

p: 909-693-2317

p: 909-382-2879

f: 909-887-3989

joseph.jordan@usda.gov

1209 Lytle Creek Road

Lytle Creek, CA 92358

www.fs.fed.us



**Caring for the land and serving
people**

This electronic message contains information generated by the USDA solely for the intended recipients. Any unauthorized interception of this message or the use or disclosure of the information it contains may violate the law and subject the violator to civil or criminal penalties. If you believe you have received this message in error, please notify the sender and delete the email immediately.



File Code: 7720
Date: December 14, 2022

Matthew Mielke
Project Manager
U.S. Department of Transportation
Federal Railroad Administration
Office of Regional Outreach & Project Delivery
1200 New Jersey Avenue, SE
Washington, DC 20590

Dear Mr. Mielke:

The San Bernardino National Forest (SBNF) appreciates the opportunity to comment on the Brightline West Cajon Pass High-Speed Rail Project. The SBNF reviewed the draft Environmental Assessment (EA) prepared for this project and some concerns were identified. These concerns pertain to habitat connectivity and wildlife movement, existing land uses, transportation, and planned forest projects. Details of these concerns are explained in greater detail below.

1. Section 4.5, Biological Resources: General Measure (GM) 25- Maintain Existing Wildlife Crossings indicates existing wildlife crossings will be modified or redesigned to ensure crossings are functional. Modified wildlife crossings should maintain pre-existing characteristics, such as terrain and natural light, to the maximum extent practicable.
2. Section 4.8, Land Use and Community Facilities: Multiple utilities and easements within the Cajon Pass exist and cross Interstate 15. These include: overhead high voltage electrical transmission lines, underground natural gas and aviation fuel pipelines, and underground fiber optic communication lines. An existing BNSF communication site also exists in the I-15 median near Oak Hills. Vehicle access to this facility will need to be maintained. Coordination with the utility companies that manage this infrastructure will be needed.
3. Section 4.12, Transportation: National Forest System Roads exist in the project area and include: 3N21, 3N24, 3N53, and 3N55. Long-term access of these roads will need to be maintained. Coordination of short-term impacts with the SBNF will also be needed.
4. SBNF signed a decision in 2018 for an ignition reduction project along I-15 through the Cajon Pass, in coordination with CalTrans. This project will reduce hazardous fuels along the I-15 corridor with the objective to reduce wildfire starts and risk.



Thank you for the opportunity to comment on this project. Should you have any follow-up questions, please contact Joseph Rechsteiner, Front Country District Ranger, at joseph.rechsteiner@usda.gov or 909-382-2860.

Sincerely,

X

N. JAMAHL BUTLER
Acting Forest Supervisor

cc: Joseph Rechsteiner



Department of Public Works

- Flood Control
- Operations
- Solid Waste Management
- Special Districts
- Surveyor
- Transportation

Brendon Biggs, M.S., P.E.
Director

Noel Castillo, P.E.
Assistant Director

November 28, 2022

Transmitted Via Email

File: 10(ENV)-4.01

U.S. Department of Transportation
Federal Railroad Administration Attn:
Matthew Mielke, Project Manager
Matthew.mielke@dot.gov

RE: NEPA- NOTICE OF AVAILABILITY OF ENVIRONMENTAL DOCUMENT FOR THE BRIGHTLINE WEST CAJON PASS HIGH-SPEED RAIL PROJECT

Dear Matthew Mielke:

Thank you for allowing the San Bernardino County Department of Public Works the opportunity to comment on the above-referenced project. **We received this request on November 1, 2022** and pursuant to our review, we have the following comments for your consideration and inclusion into public record:

Flood Control Planning & Water Resources Division (Michael Fam, Chief, 909-387-8120):

The Project is part of:

- Comprehensive Storm Drain Plan (CSDP) No. 2 - March 1969
- CSDP No. 7 - December 1982
- Rancho Cucamonga CSDP-January 1981
- Master Plan of Drainage (MPD)- Fontana MPD-June 1992
- Victorville MPD - March 1992

1. According to the most recent FEMA Flood Insurance Rate Map (FIRM), Panels 06071C5175H, 5810H, 5815H, 5830H, 6475H, 6480H, 6490H, 7180H, 7185H, 7190H, 7905, 7910H, 7915H, 7920H, dated August 28, 2008; 06071C7895J, 8635J, dated September 26, 2014; 06071C5820J, 8633J, dated September 2, 2016, the Project lies within Zones D, A, AE, X-shaded (500-yr. floodplain; protected by a levee), X, and the Regulatory Floodway. Any impacts and proposed mitigation associated with the project's occurrence within the described Flood Zones should be discussed in the environmental document prior to adoption or certification.

BOARD OF SUPERVISORS

COL. PAUL COOK (RET.)
First District

JANICE RUTHERFORD
Second District

DAWN ROWE
Vice Chair, Third District

CURT HAGMAN
Chairman, Fourth District

JOE BACA, JR.
Fifth District

Leonard X. Hernandez
Chief Executive Officer

2. One of the benefits of the CSDP/MPD is to identify the potential alignments of future drainage and flood control facilities. It is recommended for the U.S. Department of Transportation (USDOT) to continue to use this document to protect the alignment of future facilities.
3. Those portions of the Project lying in and abutting the natural drainage course and its overflow area may be subject to infrequent flood hazard until adequate channel and debris retention facilities are provided to intercept and conduct the flows through and away from the site. Potential impacts from flooding or proposed flood protection and any proposed mitigation should be discussed with the environmental document prior to adoption or certification.
4. We recommend that the USDOT enforce, at a minimum, the most current FEMA regulations for construction within a Special Flood Hazard Area (SFHA) and floodplain.
5. We are aware that drainage facilities may be affected by the Project. When planning for or altering existing or future drainage facilities, be advised that drainage reports are available through the San Bernardino County Flood Control District (District) Planning Division's office. Drainage improvements should be reviewed and approved by the jurisdictional agencies in which they occur (i.e., cities, county). Should construction of new, or alterations to existing storm drains be necessary as part of the Proposed Project, their impacts and any required mitigation should be discussed within the environmental document before the document is adopted by the Lead Agency.

Permits/Operations Support Division (Fong Tse, Chief, 909-387-7995):

1. From the information provided, it appears that the project crosses several San Bernardino County Flood Control District (District) facilities and right-of-way and would require a fully executed permit for all impacted facilities from the District prior to start of any construction activities. Currently the Project is under review (Permit FCCON-2022-00034) with the District Permit Section. Please continue with this review process and update the District with any new activities or impacts to its facilities. Also, District facilities built by the Army Corps of Engineers (ACOE) will require the District to obtain approval (408-Permit) from the ACOE. Please contact the San Bernardino County Flood Control Permit Section at (909) 387-7995 for further information regarding this process. The necessity for permits, and any impacts associated with them, should be addressed in the environmental document prior to adoption and certification. If you have any questions regarding this process, please contact the District Permit Section at (909) 387-1863.

We respectfully request to be included on the circulation list for all project notices, public reviews, or public hearings. In closing, I would like to thank you again for allowing the San Bernardino County Department of Public Works the opportunity to comment on the above-referenced project. Should you have any questions or need additional clarification, please contact the individuals who provided the specific comment, as listed above.

Sincerely,

Nancy Sansonetti

Nancy Sansonetti, AICP
Supervising Planner
Environmental Management

Comments from Local Businesses and Organizations



November 15, 2022

Federal Railroad Administration
1200 New Jersey Ave SE
Washington, DC 20590

RE: Brightline West Cajon Pass Environmental Assessment – SUPPORT

Dear Committee members,

On behalf of the Inland Empire Economic Partnership (IEEP) and the industry we represent, I am writing to express our support for the Brightline West Project. The I-15 FWY corridor through the Cajon Pass serves as a critical and vital link between our desert communities and the greater Inland Region. Our desert workforce is largely made up of commuters that travel south into the adjacent regions. As such, the corridor is at capacity and has been identified as one of the most dangerous freeways in the nation. The Brightline West will connect our communities without the need for more vehicles on the corridor.

Because of its proximity to the ports of Los Angeles and Long Beach, the Inland Region is home to a vibrant logistics industry. Every year, over half of all US freight arrives at these ports and it's transported through the Inland Empire, this includes the I-15 FWY, which serves as a major economic linkage between Southern California and Las Vegas, the greater States of Nevada, Utah and Arizona. The Brightline West Project will ease congestion and alleviate pollution in the adjacent communities.

We have seen the success of a similar project in the State of Florida and welcome the economic benefits this project will bring to our region, and for job creation in our region.

For the reasons stated above and many more the IEEP is proud to support the Brightline West Project, we look forward to the execution of the project and will continue to show support through completion. Should you have any questions please contact me at blopez@ieep.com or at 909.944.2201. Thank you for your consideration.

Sincerely,

A handwritten signature in black ink, appearing to be "B. Lopez", enclosed within a hand-drawn circular scribble.

Benjamin G. Lopez
Director of Public Policy and Advocacy



RailPAC
Rail Passenger Association
of California and Nevada

P.O. Box 22344
San Francisco CA 94122

www.railpac.org

Matthew Mielke, Environmental Protection Specialist
Environmental Review Division
Federal Railroad Administration
1200 New Jersey Avenue, SE
West Building, Mail Stop 20
Washington, DC 20590

November 25, 2022

Re: Brightline West Cajon Pass High Speed Rail Environmental Assessment

Dear Mr. Mielke

I am writing on behalf members of the Rail Passenger Association of California and Nevada (RailPAC) an all-volunteer, 501(c)3, statewide organization that advocates for the improvement of commuter and intercity passenger rail service. Outlined below are RaiPAC's comments on the Brightline West Cajon Pass High Speed Rail Environmental Assessment between Victor Valley and Rancho Cucamonga.

RailPAC concurs with the FRA's assessment that this proposed project will not have a significant impact on the environment and RailPAC finds it will in fact have positive environmental impacts by providing an alternative to automobile travel while fostering transit oriented development. The project will provide valuable new capacity to the congested I-15 corridor, while offering a new travel option. High-speed rail will improve travel times, improve reliability and will reduce future vehicle miles traveled. The capacity increase this project will bring to the I-15 corridor will reduce the need for additional environmentally detrimental freeway widening projects.

This project will also leverage Southern California's transit network, both directly with connections at Rancho Cucamonga with Metrolink's San Bernardino line, but also at Los Angeles Union Station with LA Metro and other Metrolink lines.

The Rail Passenger Association of California and Nevada fully supports the Brightline West Las Vegas to Rancho Cucamonga high-speed rail project. Thank you for the opportunity of address this issue.

Sincerely,

Steve Roberts, President Rail Passenger Association of California and Nevada

PUBLIC SUBMISSION

As of: November 29, 2022
Received: November 28, 2022
Status: Posted
Posted: November 28, 2022
Category: Notice / Order
Tracking No. lb1-6qzo-qshz
Submission Type: Web

Docket: FRA-2022-0090
Brightline West Cajon Pass High-Speed Rail Project Environmental Assessment

Comment On: FRA-2022-0090-0001
Brightline West Cajon Pass Environmental Assessment -Final

Document: FRA-2022-0090-0017
Comment from Inland Action, Inc.

Submitter Information

Email: dbarmack@inlandaction.com
Organization: Inland Action, Inc.

General Comment

November 28, 2022

These comments are related to the Environmental Assessment for the Victor Valley to Rancho Cucamonga portion of the Brightline West project released by the Federal Railroad Administration. Inland Action is a non-profit, non-partisan corporation of public-spirited leaders who have joined together to be catalysts for the economic well-being of the Inland Empire region of California since 1962.

The Victor Valley to Rancho Cucamonga portion of the Brightline West project is a significant project for residents of San Bernardino County, as well as all the interstate travelers and industries who make their way through the Cajon Pass on a daily basis. This project will significantly enhance connectivity through the I-15 corridor, reduce emissions and congestion, create jobs, and spur economic activity in surrounding communities.

The Brightline project will play a key role in the series of multimodal solutions which include the expansion of public transit with Arrow service, as well as projects like the West Valley Connector, Express Lanes network, and Zero-Emission Multiple Unit, our contribution to the nation, that are currently in San Bernardino County Transportation Authority's project pipeline.

We look forward to approval of this Environmental Assessment and full development of this project.



INLAND EMPIRE BIKING ALLIANCE

28 November 2022

Matthew Mielke, Environmental Protection Specialist
Environmental Review Division
Federal Railroad Administration
1200 New Jersey Avenue, SE
West Building, Mail Stop 20
Washington, DC 20590

Submitted via email to matthew.mielke@dot.gov.

Re: Brightline West – Cajon Pass High-Speed Rail Project Environmental Assessment

Dear Mr. Mielke,

This letter is being submitted on behalf of the Inland Empire Biking Alliance to respond to the Environmental Assessment which has been released for review for the Brightline West – Cajon Pass High-Speed Rail Project that has been proposed here in the region. After reviewing the documents, there are a few things which have been overlooked and need to be addressed.

The first is regarding Section 6.1.1.4 Active Transportation, 6.1.2.4 Active Transportation, and 6.2.4 Active Transportation of the Traffic and Transportation Technical Report. These sections state that the Project is not anticipated to affect active transportation because it is along rights-of-way not believed to be intended for bicycle or pedestrian use. However, this is not correct. Caltrans allows bicycles the use of freeway shoulders in areas where there are no other alternatives options for travel and the Project encompasses one such portion of Interstate 15 (I-15).

Per the Caltrans District 8 State Highway System Bicycle Access Map¹, bicycles are allowed to use I-15 in the Project area from Cleghorn Road to Oakhill Road in both directions. Thus, the Project should be sure to mitigate any impacts that would be incurred on bicyclists for that area to ensure that bicycle travel remains available both during construction and in the after condition once the Project is complete.

Additionally, it seems unrealistic that forecast mode split to either the Rancho Cucamonga or Hesperia stations would not include anyone arriving by bicycling or walking. While it is true that many potential customers and employees would arrive by driving, TNC, or transit, the planned development adjacent the Project which would include housing is certain to include some individuals who would choose to not drive to the Rancho Cucamonga station. Furthermore, both bicycling and

¹ Caltrans District 8 State Highway System Bike Map. Retrieved online from <https://www.arcgis.com/apps/webappviewer/index.html?id=c81d3ab198f64ef3a2bd211c4fc18dfe>.



INLAND EMPIRE BIKING ALLIANCE

walking are not uncommon modes of transportation used to access Amtrak and Metrolink services in the region, including at Rancho Cucamonga.

Although it is often understood to be “conservative” to assume a lower use of alternative transportation options than actual to prepare for a “worst case scenario” of drivers, it still is problematic to assume that there would not be anyone accessing any of the stations via active means, particularly if that results in failing to make efforts to change that. As has been demonstrated by a number of studies, the bike + train combination can be time-competitive with driving even on regional trains and given that Brightline West will be faster, it would greatly increase the range over which the service is seen as a viable option.

Finally, the Report states that several interchanges and overpasses of I-15 along the route potentially need to be modified or rebuilt. At the same time, the Caltrans District 8 Active Transportation Plan² acknowledges that these structures often present big barriers to active travelers. Thus, in either case but especially if being fully rebuilt, it is imperative that those efforts incorporate the guidance from the FHWA³ and Caltrans⁴ on the appropriate bikeway based on traffic speeds and volumes to ensure that the deficient conditions are not perpetuated even after major construction occurs that could correct those issues.

Thank you for taking the time to address these concerns and make sure that what is already a promising Project can deliver the best option for all travelers. If there are any further questions or comments, please do not hesitate to reach out for clarification.

Sincerely,

A handwritten signature in dark ink, appearing to read "Marven E. Norman".

Marven E. Norman, Executive Director

CC: Caltrans District 8

² Active Transportation Plan 2022: District 8. Caltrans. Retrieved online from <https://dot.ca.gov/-/media/dot-media/programs/transportation-planning/documents/active-transportation-complete-streets/caltrans-reconnecting-communities-program/d8-finalactivetransportationplan-a11y.pdf>.

³ Schultheiss, B., Goodman, D., Blackburn, L., Wood, A., Reed, D., & Elbech, M. (2019). Bikeway selection guide (FHWA-SA-18-077). US Department of Transportation, Federal Highway Administration. Retrieved from https://safety.fhwa.dot.gov/ped_bike/tools_solve/docs/fhwasa18077.pdf.

⁴ Flournoy, M. (2020). Contextual guidance for bike facilities. Caltrans. Retrieved from <https://dot.ca.gov/-/media/dot-media/programs/transportation-planning/documents/office-of-smart-mobility-and-climate-change/planning-contextual-guidance-memo-03-11-20-a11y.pdf>.



INLAND EMPIRE BIKING ALLIANCE

County of San Bernardino
City of Fontana
City of Hesperia
City of Rancho Cucamonga
City of Victorville
SBCTA

About IEBA The Inland Empire Biking Alliance is advocating for making the Inland Empire a better place for people from all rolls of life. From the children just learning how to ride to the mountain bikers to those headed back and forth to work, school, or their preferred shopping center and beyond, we speak up to make sure they all have safe and convenient place to ride.

