



U.S. Department
of Transportation
Federal Railroad
Administration

Office of Research,
Development and Technology
Washington, DC 20590

Positive Train Control Communication Failures and Their Impacts: Case Study Using Generalized Train Movement Simulator



Photo – JJ11 / Shutterstock.com (non-commercial use)

NOTICE

This document is disseminated under the sponsorship of the Department of Transportation in the interest of information exchange. The United States Government assumes no liability for its contents or use thereof. Any opinions, findings and conclusions, or recommendations expressed in this material do not necessarily reflect the views or policies of the United States Government, nor does mention of trade names, commercial products, or organizations imply endorsement by the United States Government. The United States Government assumes no liability for the content or use of the material contained in this document.

NOTICE

The United States Government does not endorse products or manufacturers. Trade or manufacturers' names appear herein solely because they are considered essential to the objective of this report.

REPORT DOCUMENTATION PAGE			<i>Form Approved</i> <i>OMB No. 0704-0188</i>
Public reporting burden for this collection of information is estimated to average 1 hour per response, including the time for reviewing instructions, searching existing data sources, gathering and maintaining the data needed, and completing and reviewing the collection of information. Send comments regarding this burden estimate or any other aspect of this collection of information, including suggestions for reducing this burden, to Washington Headquarters Services, Directorate for Information Operations and Reports, 1215 Jefferson Davis Highway, Suite 1204, Arlington, VA 22202-4302, and to the Office of Management and Budget, Paperwork Reduction Project (0704-0188), Washington, DC 20503.			
1. AGENCY USE ONLY (Leave blank)	2. REPORT DATE October 2020	3. REPORT TYPE AND DATES COVERED Final Report 2/1/2020 – 7/31/2020	
4. TITLE AND SUBTITLE Positive Train Control Communication Failures and Their Impacts: Case Study Using Generalized Train Movement Simulator		5. FUNDING NUMBERS	
6. AUTHOR(S) Daniel Brod 0000-0002-1213-0908, Daniel Alexander			
7. PERFORMING ORGANIZATION NAME(S) AND ADDRESS(ES) Decisiontek, LLC 11821 Parklawn Drive, Ste. 260 Rockville, MD 20852		8. PERFORMING ORGANIZATION REPORT NUMBER	
9. SPONSORING/MONITORING AGENCY NAME(S) AND ADDRESS(ES) U.S. Department of Transportation Federal Railroad Administration Office of Railroad Policy and Development Office of Research, Development, and Technology Washington, DC 20590		10. SPONSORING/MONITORING AGENCY REPORT NUMBER DOT/FRA/ORD-24/39	
11. SUPPLEMENTARY NOTES Project Manager: Karen McClure			
12a. DISTRIBUTION/AVAILABILITY STATEMENT This document is available to the public through the FRA website.		12b. DISTRIBUTION CODE	
13. ABSTRACT (Maximum 200 words) Railroads with Positive Train Control (PTC) are experiencing increased delays due to communication failures and outages, during which trains are compelled to move at slower speeds while operating in non-PTC fallback mode. The Federal Railroad Administration (FRA) sponsored Decisiontek, LLC to further enhance the Generalized Train Movement Simulator (GTMS) in 2020. To evaluate the operational impacts of communication outages, the team extended the GTMS to include a Communications Failure Impacts Model.			
14. SUBJECT TERMS PTC, GTMS, rail system simulation		15. NUMBER OF PAGES 69	
		16. PRICE CODE	
17. SECURITY CLASSIFICATION OF REPORT Unclassified	18. SECURITY CLASSIFICATION OF THIS PAGE Unclassified	19. SECURITY CLASSIFICATION OF ABSTRACT Unclassified	20. LIMITATION OF ABSTRACT

METRIC/ENGLISH CONVERSION FACTORS

ENGLISH TO METRIC

METRIC TO ENGLISH

<p>LENGTH (APPROXIMATE)</p> <p>1 inch (in) = 2.5 centimeters (cm)</p> <p>1 foot (ft) = 30 centimeters (cm)</p> <p>1 yard (yd) = 0.9 meter (m)</p> <p>1 mile (mi) = 1.6 kilometers (km)</p>	<p>LENGTH (APPROXIMATE)</p> <p>1 millimeter (mm) = 0.04 inch (in)</p> <p>1 centimeter (cm) = 0.4 inch (in)</p> <p>1 meter (m) = 3.3 feet (ft)</p> <p>1 meter (m) = 1.1 yards (yd)</p> <p>1 kilometer (km) = 0.6 mile (mi)</p>
<p>AREA (APPROXIMATE)</p> <p>1 square inch (sq in, in²) = 6.5 square centimeters (cm²)</p> <p>1 square foot (sq ft, ft²) = 0.09 square meter (m²)</p> <p>1 square yard (sq yd, yd²) = 0.8 square meter (m²)</p> <p>1 square mile (sq mi, mi²) = 2.6 square kilometers (km²)</p> <p>1 acre = 0.4 hectare (he) = 4,000 square meters (m²)</p>	<p>AREA (APPROXIMATE)</p> <p>1 square centimeter (cm²) = 0.16 square inch (sq in, in²)</p> <p>1 square meter (m²) = 1.2 square yards (sq yd, yd²)</p> <p>1 square kilometer (km²) = 0.4 square mile (sq mi, mi²)</p> <p>10,000 square meters (m²) = 1 hectare (ha) = 2.5 acres</p>
<p>MASS - WEIGHT (APPROXIMATE)</p> <p>1 ounce (oz) = 28 grams (gm)</p> <p>1 pound (lb) = 0.45 kilogram (kg)</p> <p>1 short ton = 2,000 pounds (lb) = 0.9 tonne (t)</p>	<p>MASS - WEIGHT (APPROXIMATE)</p> <p>1 gram (gm) = 0.036 ounce (oz)</p> <p>1 kilogram (kg) = 2.2 pounds (lb)</p> <p>1 tonne (t) = 1,000 kilograms (kg) = 1.1 short tons</p>
<p>VOLUME (APPROXIMATE)</p> <p>1 teaspoon (tsp) = 5 milliliters (ml)</p> <p>1 tablespoon (tbsp) = 15 milliliters (ml)</p> <p>1 fluid ounce (fl oz) = 30 milliliters (ml)</p> <p>1 cup (c) = 0.24 liter (l)</p> <p>1 pint (pt) = 0.47 liter (l)</p> <p>1 quart (qt) = 0.96 liter (l)</p> <p>1 gallon (gal) = 3.8 liters (l)</p> <p>1 cubic foot (cu ft, ft³) = 0.03 cubic meter (m³)</p> <p>1 cubic yard (cu yd, yd³) = 0.76 cubic meter (m³)</p>	<p>VOLUME (APPROXIMATE)</p> <p>1 milliliter (ml) = 0.03 fluid ounce (fl oz)</p> <p>1 liter (l) = 2.1 pints (pt)</p> <p>1 liter (l) = 1.06 quarts (qt)</p> <p>1 liter (l) = 0.26 gallon (gal)</p> <p>1 cubic meter (m³) = 36 cubic feet (cu ft, ft³)</p> <p>1 cubic meter (m³) = 1.3 cubic yards (cu yd, yd³)</p>
<p>TEMPERATURE (EXACT)</p> <p>$[(x-32)(5/9)]\text{ }^{\circ}\text{F} = y\text{ }^{\circ}\text{C}$</p>	<p>TEMPERATURE (EXACT)</p> <p>$[(9/5)y + 32]\text{ }^{\circ}\text{C} = x\text{ }^{\circ}\text{F}$</p>

QUICK INCH - CENTIMETER LENGTH CONVERSION

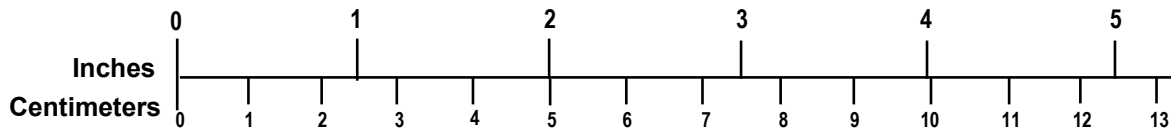

QUICK FAHRENHEIT - CELSIUS TEMPERATURE CONVERSION

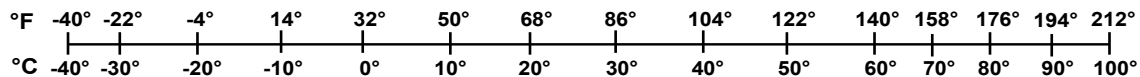

For more exact and or other conversion factors, see NIST Miscellaneous Publication 286, Units of Weights and Measures. Price \$2.50 SD Catalog No. C13 10286

Updated 6/17/98

Acknowledgements

The authors appreciate the insightful review comments by Federal Railroad Administration (FRA) staff Karen McClure and Francesco Bedini Jacobini, and acknowledge the ongoing support of Sam Al-Ibrahim of FRA's Train Control and Communication Division.

The team thanks Joseph Brosseau and Paolo Vieira of Transportation Technology Center, Inc. (TTCI) for their helpful review and comments on the GTMS Communications Failure Impact Model design document. Related work by TTCI was extremely useful in helping to clarify and implement the model.

Continuing appreciation is extended to Corey Pasta and Ed Tilley of BNSF Railway, who provided the rail infrastructure data and I-ETMS subdivision data files for the analysis.

Contents

Executive Summary	1
1. Introduction.....	2
1.1 Background.....	2
1.2 Objectives	2
1.3 Overall Approach	3
1.4 Organization of the Report	3
2. Description of the Territory	5
2.1 Subdivisions.....	5
2.2 Timetable Routes	6
3. Description of Traffic Flows on the Network.....	7
4. Communication Failure Scenarios	8
4.1 Scenario Framework.....	8
4.2 Summary of Scenarios Considered	11
4.3 Selected Scenarios.....	11
5. Findings	13
6. Conclusion	16
7. References.....	17
Appendix A. Stringline Charts	19
Appendix B. Representative Speed Charts.....	24
Appendix C. Track Charts of Territory.....	27
Appendix D. Node Network Diagram (Traffic Control Blocks).....	51
Appendix E. Communications Failure Logic Flows.....	58

Illustrations

Figure 2-1. Territory Map (Source: BNSF System Map)	5
Figure 2-2. Territory Schema	6
Figure 5-1. Scenario 3.02 Base Station Failures.....	13
Figure 5-2. Scenario 3.02 Base Station Failures – Zoomed View.....	14
Figure 5-3. Scenario Results – Average Speeds.....	14
Figure 5-4. Scenario Results – Mean Delay	15

Tables

Table 3-1. Daily Trains by Timetable Route.....	7
Table 4-1. Communications Event Terms and Definitions.....	8
Table 4-2. Train-Originating Incidents.....	9
Table 4-3. Communications-Originating Incidents.....	10
Table 4-4. Communications Failure Scenarios Considered – Injected.....	11
Table 5-1. Scenario Results – Average Speeds.....	15
Table 5-2. Scenario Results – Mean Delay.....	15

Executive Summary

Railroads with Positive Train Control (PTC) are experiencing increased delays due to communication (comm) failures and outages, during which trains are compelled to move at slower speeds while operating in non-PTC fallback mode. The Federal Railroad Administration (FRA) sponsored Decisiontek, LLC to further enhance the Generalized Train Movement Simulator (GTMS) in 2020. To evaluate the operational impacts of communication outages, the team extended the GTMS to include a Communications Failure Impacts Model.

Comm failures (sometimes referred in this document as “incidents” or “events”) result from equipment failure or human error in conjunction with a PTC system component. These components include: the train’s onboard computer, wayside interface units, base station, comm backbone, and back office system (BOS).

The territory studied includes three inter-connected subdivisions north and west of Ft. Worth, TX. Traffic flows in the territory were derived from publicly available sources and included 38 daily trains representing a mix of freight, intermodal, and passenger trains.

Researchers considered an array of injected (i.e., scripted) and random communication failure events. The analysis simulated a baseline scenario without failures, and four scenarios of injected failures. The scenarios of injected failures covered the following incident types: 1) onboard recoverable incidents, 2) onboard non-recoverable incidents, 3) base station failures, and 4) BOS failures.

This case study demonstrated the impact of select communication failure scenarios on operational performance using extended GTMS software. Researchers measured the impacts as changes in average speed and mean delay for three train types: freight, intermodal, and passenger.

In general, average speeds declined, depending on scenario and train type, by between 0.6 percent to as much as 13.8 percent. In a few cases there were increased speeds of 0.9 to 3.6 percent for some train types and scenarios. While an outage may slow individual trains, or, trains in a particular area for some period of time, it also creates opportunities for other trains in other parts of the territory to advance more rapidly (i.e., trains not directly impacted by comm failures will receive movement authorities sooner in order to fill idle capacity).

In the failure scenarios, mean delay by train type increased, generally. Some of the average delay increases were very significant. For example, with base station failures, the mean delay for intermodal trains increased by 89 minutes. Many delay increases (by scenario and train type) were less pronounced. For some scenarios and train types, there were even delay reductions.

The research team concludes that the method and GTMS software were effective tools for analyzing comm failure impacts, and the evaluation of possible mitigating measures, in a complex rail network.

1. Introduction

The Federal Railroad Administration (FRA) sponsored Decisiontek, LLC to further enhance the Generalized Train Movement Simulator (GTMS) in 2020. To evaluate the operational impacts of communication outages, the team extended the GTMS to include a Communications Failure Impacts Model (CFIM).

1.1 Background

With the deployment of Positive Train Control (PTC) systems across the U.S. rail network (a multi-year process which is near completion¹), new operational delays have arisen due to occasional PTC system component failures, resulting in communication outages. While these outages are not believed to compromise safety, railroads have noted that the delays are having a significant operational impact.

The PTC system operates with two networks: one that carries communications for core traffic control functionality (e.g., movement authorities), and one that communicates the presence of hazards through wayside devices. Failures in either or both networks require trains to stop as part of a fail-safe response. Trains may continue operating in fallback mode, which is non-PTC operation meeting safety-critical criteria that is specific to the territory and backup traffic control method.

Fallback mode, if permitting movement, requires trains to operate at lower speeds than would have been required without the outage. In some lighter traffic scenarios, delays may be restricted to the impacted trains themselves. However, in many realistic scenarios, delay will likely cascade to affect additional trains and, generally, disrupt scheduled traffic.

As part of its response to the evolving railroad environment with PTC, FRA sought to enhance the GTMS with a dedicated module that would estimate the impacts of PTC communication failures. This case study was prepared using the modified GTMS software.

1.2 Objectives

The objectives of this case study are:

- Estimate the operational impacts of PTC communication failures on a complex rail network.
- Demonstrate the capabilities of GTMS- CFIM and its applicability to railroads as a tool for planning and potentially supporting mitigation of operational risk² due to PTC communication failures.

¹ See reported progress on PTC implementation, “[Steps Toward Full PTC System Implementation of Mandated Positive Train Control \(PTC\) Systems.](#)”

² Possible mitigation strategies are beyond the scope of this report. Such strategies could include schedule modifications or adding system redundancies to reduce outages.

1.3 Overall Approach

The case study was developed with the GTMS-CFIM. The model follows the specification provided in Decisiontek (2018).

The CFIM module integrates with the GTMS core operational model. Before considering the communication failure impacts, GTMS assesses railroad operations – based on detailed infrastructure and traffic information – and provides a broad set of outputs including stringline, speed and delay charts, and tables of output metrics. The case study compares failure scenario simulations against an operational baseline (i.e., without failure) simulation.

For simulations incorporating communications failure scenarios, GTMS-CFIM measures the operational impact of communications-related errors and failures causing outages (referred to as “events”). There are several communications event types, ranging from equipment failure to human error, that may affect train operations.

There are five basic event categories:

- Train originating events
- Wayside interface unit (WIU) originating events
- Base station originating events
- Back office events
- Communication backbone events

GTMS-CFIM provides two methods of introducing communications events into simulations: injection and random occurrence. Injected (or scripted) events are pre-defined by the user. Injected events are used to measure the impact of particular failures or errors, that occur at specific times, to specific equipment. Random events are based on user-inputted rates of errors or equipment failures.

Scenarios with random events are best used to model the effects of communications failures for a system over a specified time period. Such scenarios also provide informative inputs to assessments of reliability, availability (i.e., uptime) and maintainability.

Scenarios based on scripted events assess the operational impacts on the network of specific event sequences that are defined by users. The defined scenarios may represent “worst case” or other situations that a railroad may wish to better understand and prepare for. As the scenario events are scripted, they do not inform regarding the probability of such a sequence occurring.

For the case study, GTMS-CFIM was applied to part of the BNSF Railway network comprising three subdivisions. Traffic scenarios (i.e., train schedule and consists) were developed using publicly available information and are described in [Section 3](#).

The case study focuses on four scenarios representing a range of communications outage events and are described in [Section 4](#).

1.4 Organization of the Report

[Section 2](#) describes the territory used in the case study. [Section 3](#) describes the traffic flows used in the case study analysis. [Section 4](#) presents the communications failure scenarios of the analysis. [Sections 5](#) and [6](#) present the findings and conclusions of the analysis.

The appendices are organized as follows:

[Appendix A](#): Simulation Stringline Charts. GTMS generated these charts from the simulation outputs, essentially showing time and position of trains in the system (viewed by timetable routes). Charts are shown for the baseline (no failures) and for each simulated scenario. The stringlines illustrate the impact of slower trains running in fallback mode on the system's overall performance.

[Appendix B](#): Representative Speed Charts. The speed charts shown are representative of the three different train types (e.g., freight, intermodal and passenger) that run in the territory. These indicate the speed of trains along its route against speed limits while showing elevations and state of train controls (i.e., throttle position and air brakes).

[Appendix C](#): Track Charts. The track charts show the detailed track infrastructure, including track, grades, curves, speed restrictions, running distance, and mileposts. Track charts are displayed by subdivision.

[Appendix D](#): Node Network Diagrams. These diagrams are generated by GTMS and are maps of the traffic control blocks used by GTMS for safe and non-deadlocking dispatching.

[Appendix E](#): Comm Failure Logic Flows. The diagrams in this appendix show the logic of comm failure event propagation as implemented in GTMS.

2. Description of the Territory

2.1 Subdivisions

The territory consists of three BNSF Railway subdivisions located north and west of Ft. Worth, Texas. The three subdivisions are:

- Ft. Worth (North) – the subdivision runs north 69.8 miles from Tower 55 to Gainesville. The subdivision includes entry and exit to the Alliance Global Logistics Hub.
- Wichita Falls – the subdivision runs 114.1 miles northwest from near Tower 55 to Wichita Falls.
- Red Rock – the subdivision runs north 259.1 miles from Gainesville through Oklahoma City to Arkansas City.

Territory infrastructure data were imported to GTMS from I-ETMS subdivision files provided by BNSF Railway.³ Appendix C shows mile-by-mile track charts for each subdivision generated by GTMS – including track, grades, curves, and speed restrictions. The track charts also show the points of linkage between the subdivisions.

Figure 2-1 shows the locations of the subdivisions on the BNSF system map.

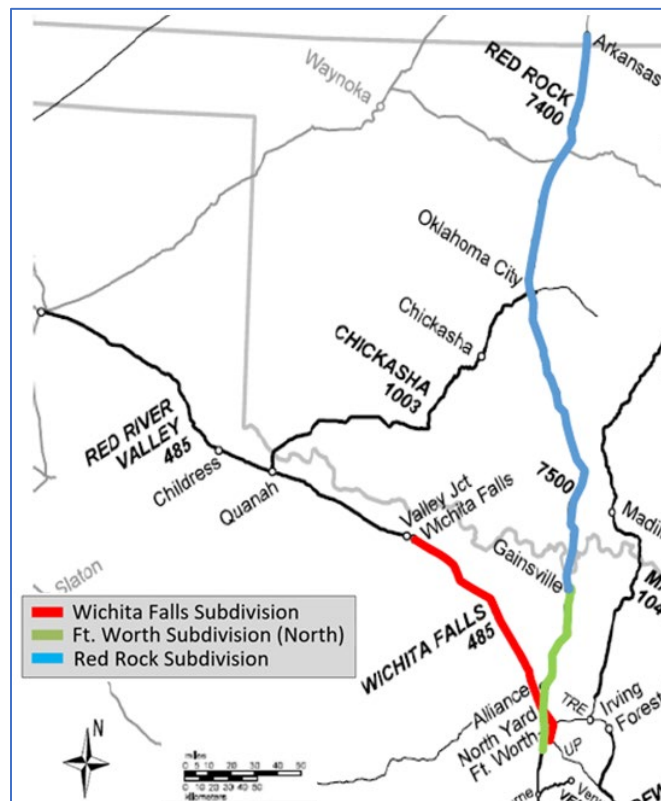

Figure 2-1. Territory Map (Source: BNSF System Map)

³ The infrastructure data were provided for related studies in 2014 and are current to that time.

2.2 Timetable Routes

GTMS requires that users specify “timetable routes,” the possible routes through which trains may be scheduled (terminus-to-terminus, including scheduled station stops). Users assign a timetable route and schedule to each train in a simulation.

In general, there will be multiple paths (i.e., sequences of blocks of track) through which a scheduled train may progress along its timetable route. In simulation (as in real-world operations), the Central Dispatcher in GTMS assigns movement authorities to trains along specific blocks of track.

For example, in the case study territory, one timetable route is Ft. Worth to Arkansas City, spanning the two subdivisions of Ft. Worth and Red Rock. For convenience, researchers designated termini with an identifying letter and refer to the timetable route as a pair of termini. Ft. Worth (terminus A) to Arkansas City (terminus C) is referred to as timetable route AC.

A schema of the territory and its timetable routes are shown in [Figure 2-2](#).

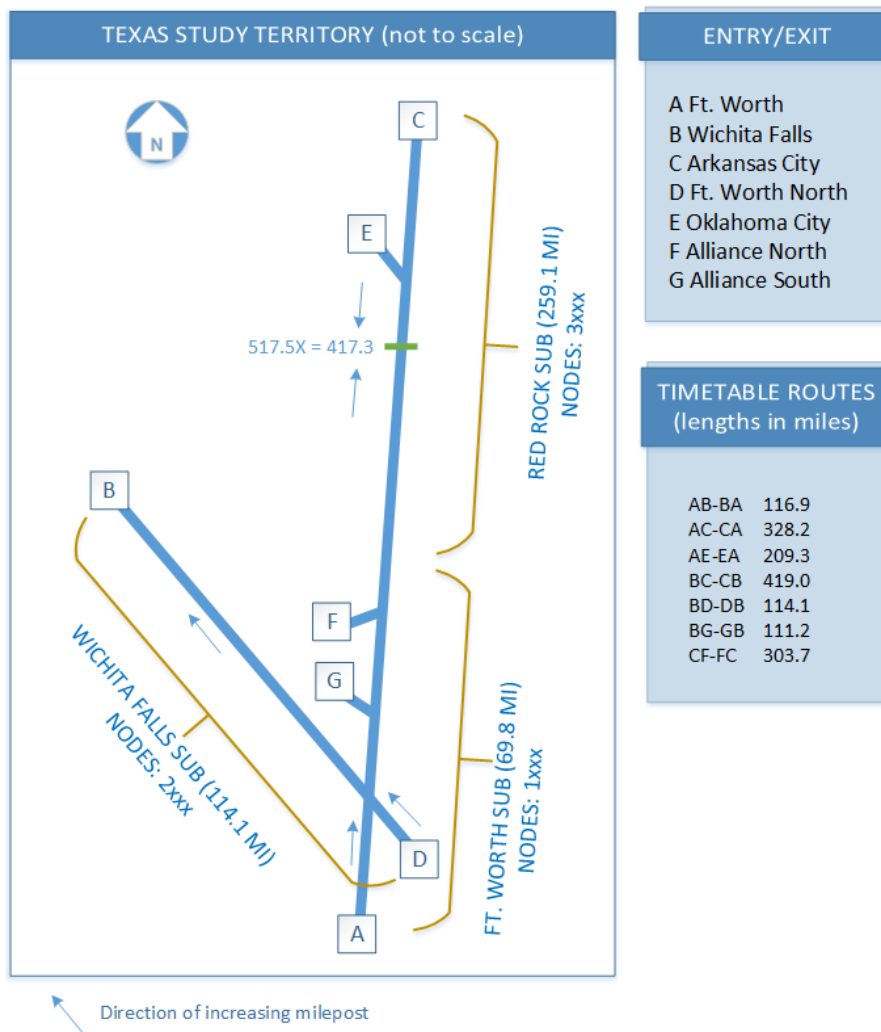

Figure 2-2. Territory Schema

3. Description of Traffic Flows on the Network

Traffic flows in the territory are based on two publicly accessible sources:

- Daily trains, per FRA’s National Grade Crossing Inventory System
- Amtrak schedules (i.e., the passenger trains in the study are from Amtrak’s Heartland Flyer service between Ft. Worth and Oklahoma City).

Freight trains had 120 cars, length of 6,980 feet with loaded weight of 17,900 tons, and light weight of 4,940 tons. Intermodal trains had 30 cars, length of 5,900 feet with loaded weight of 7,400 tons and light weight of 2,610 tons. Passenger trains had twenty cars. The analysis assumed that trains originating or terminating at the Alliance Hub were intermodal, while freight trains to and from other termini were non-intermodal, general freight.

Power configurations were matched so that horsepower per ton was within typical operating ranges.

A total of 38 daily trains were simulated over a 3-day period by timetable route, as shown in [Table 3-1](#):

Table 3-1. Daily Trains by Timetable Route

ID	Timetable Route	Number of Daily Trains	Type	Loaded / Empty
AB	Ft. Worth – Wichita Falls	2	Freight	E
BA	Wichita Falls – Ft. Worth	2	Freight	L
AC	Ft. Worth – Arkansas City	4	Freight	L
CA	Arkansas City – Ft. Worth	2	Freight	E
AE	Ft. Worth – Oklahoma City	1	Passenger	--
EA	Oklahoma City – Ft. Worth	1	Passenger	--
BC	Wichita Falls – Arkansas City	3	Freight	L
CB	Arkansas City – Wichita Falls	3	Freight	E
BD	Wichita Falls – Ft. Worth North	2	Freight	L
DB	Ft. Worth North – Wichita Falls	2	Freight	E
BG	Wichita Falls – Alliance South	4	Intermodal	L
GB	Alliance South – Wichita Falls	4	Intermodal	E
CF	Arkansas City – Alliance North	4	Intermodal	E
FC	Alliance North – Arkansas City	4	Intermodal	L

4. Communication Failure Scenarios

This section presents the communication failure scenarios. The scenario framework is presented, followed by a summary of the events considered. The section concludes with a description of the four injected scenarios included in this case study.

4.1 Scenario Framework

The GTMS-CFIM module captures the impacts of all communication failure events. The events and their operational impact are shown in [Appendix C](#).

GTMS-CFIM organizes events and parameters as follows:

The collection of injected (i.e., scripted) and random events for each event type is referred to as a Parameter Set. A grouping of Parameter Sets makes up a Communications Failure Scenario, which can be applied to a simulation Job. Additionally, a Communications Failure Scenario includes a set of Fallback parameters, used to configure the behavior of trains when operating in Fallback Mode. Some communications events dictate that trains must enter Fallback Mode until the incident is resolved.

[Table 4-1](#) shows the basic terms and definitions used in the GTMS-CFIM.

Table 4-1. Communications Event Terms and Definitions

Term	Definition
CFIM	Communications Failure Impact Model: GTMS system for simulating and modeling the effects of failures in communications devices
Back Office	Communications and dispatching hub for all trains and communications devices
Base Station	Communications device that allows trains and WIUs to communicate with a back office.
Comm Backbone	Communications cabling (usually fiber-optic), connecting PTC non-train components (WIUs, base stations, back office)
WIU	Wayside Interface Unit: a bungalow or enclosure containing electronic equipment along the railroad right-of-way that communicates with trains, wayside devices (e.g., signals and switches), and base stations.
Event/Incident/Failure	Interchangeable terms; refers to when, due to equipment failure or human error, a component of a PTC system (e.g., train, WIU, and base station) fails to operate properly
Communications Failure Scenario	Set of Communications Model Parameter Sets
Communications Model Parameter Set	Set of injected and random event definitions that define when and what types of communication failure events will occur in a simulation.
Injected Event	A communications failure event that occurs at a time or location designated by the user.
Random Event	A communications failure event that occurs randomly; failure rates are defined by the user.

Table 4-2 (for train-originating incidents) and Table 4-3 (for communications-originating incidents) show the communication failure events and their operational impact.

Table 4-2. Train-Originating Incidents

ID	Category	Event	Operational Impact
TR01	Train Initialization	System Error Delay Departure	Causes delay to train departure. Train subsequently departs with normal PTC operation.
TR02		Human Error Delay Departure	Causes delay to train departure. Train subsequently departs with normal PTC operation.
TR03		Human Error Non-Recoverable	Causes train to operate disengaged per PTC Overlay Fallback mode until destination.
		Equipment Failure Non-Recoverable	
TR04	Onboard Event Enroute	Onboard Failure Non-Recoverable	Causes train to stop, cut-out brakes, and resume operation per PTC Overlay Fallback mode.
TR05		Onboard Failure Recoverable	Causes train to stop, resume normal PTC operation after delay.
TR06		Software Defect Recoverable	Causes train to stop, resume normal PTC operation after delay.
TR07		PTC Disengagement Non-Recoverable	Causes train to slow to fallback speed, operate per PTC Overlay Fallback mode until destination.
TR08		PTC Disengagement Recoverable	Causes train to slow to fallback speed, operate per PTC Overlay Fallback mode until recovery.
TR09		Human Error Enroute	Failure to Confirm Non-Signaled Switch Position
TR10	Human Error on Route with PTC Enforcement		Causes train to stop, resume operating at normal PTC operation after delay.
TR11	Office Fault with Train	Train-Office Synchronization Fault	Causes the train to slow to fallback speed, operate per PTC Overlay Fallback mode until recovery.

Table 4-3. Communications-Originating Incidents

ID	Category	Event	Operational Impact
WI01	WIU Non-Communicating	WIU Message Status not received from intermediate signal.	Causes a Stop target to be applied at the intermediate signal. If the signal indication is Restricting, the Stop target is lifted when the train speed is at or below the maximum speed for Restricted Speed and a Restricted Speed limit is applied for the next signal block. If the signal indication is Stop and Proceed, the Restricted Speed limit is applied after the train has stopped.
WI02		WIU Message Status not received from absolute signal.	Causes train to slow down per stop target at signal, stop to obtain dispatch authority and operate at Restricted Speed through next signal block then resume normal PTC operation.
WI03		WIU Msg Status not received from monitored switch in non-signaled territory.	Causes train to slow down per stop target at inoperative WIU, operate at normal permitted speeds after crew confirms switch position.
BS01	Base Station Non-Communicating	Base station failure causes trains to disengage PTC (WIUs have own radio).	Enter PTC Fallback mode when (first to occur): 1) BOS heartbeat timeout (558 seconds): Trains operate in fallback until coverage regained. 2) Train at end-of-authority: Stop and wait for authority, then resume in fallback until coverage restored.
BS02		Base station failure causes WIU messages not to be transmitted (WIUs do not have own radio).	Enter PTC Fallback mode when (first to occur): 1) BOS Heartbeat timeout (558 seconds): Trains operate in fallback until coverage restored. 1) Train at end-of-authority: Stop and wait for authority, then resume in fallback until coverage restored. 2) Train needs to communicate with WIU: Trains to operate per WI01, WI02, WI03 above.
BS02		Base station failure causes WIU messages not to be transmitted (WIUs do not have own radio).	Enter PTC Fallback mode when (first to occur): 1) BOS Heartbeat timeout (558 seconds): Trains operate in fallback until coverage restored. 2) Train at end-of-authority: Stop and wait for authority, then resume in fallback until coverage restored. 3) Train needs to communicate with WIU: Trains to operate per WI01, WI02, WI03 above.
OF01	Back Office Failure	Office services down	All trains to run in fallback mode.
CB01	Comm Backbone Failure	Trunk communication line controlling multiple WIUs fails.	WIUs wired to the comm backbone fail as per WI01, WI02, and WI03 above.

Source: TTCI

4.2 Summary of Scenarios Considered

The analysis focused on injected events (see [Table 4-4](#)). Randomly generated events were not included in the case study. While important for specific analytic tasks, the project team believes that exposition of the CFIM is improved by focusing only on the scripted events without the need to assess the effects of randomness.

Table 4-4. Communications Failure Scenarios Considered – Injected

ID	Failure Category	Duration	Description
1.01	Train (Recoverable)	Low	Recoverable train originating incidents (human/OBC/equipment failures): short restore times
1.02	Train (Recoverable)	High	Recoverable train originating incidents (human/OBC/equipment failures): long restore times
1.03	Train (Unrecoverable)	High	Unrecoverable train originating incidents (human/OBC/equipment failures): PTC service cannot be restored.
2.01	WIU	Low	WIU failures at high traffic locations and times: short failure duration
2.02	WIU	High	WIU failures at high traffic locations and times: long failure duration
3.01	Base Station	Low	Base station failure at high traffic locations and times: short failure duration
3.02	Base Station	High	Base station failure at high traffic locations and times: long failure duration
4.01	Back Office	Low	Back office failure during peak traffic hours per subdivision: short failure duration
4.02	Back Office	High	Back office failure during peak traffic hours per subdivision: long failure duration
5.01	Comm Backbone	Low	Comm backbone failure during peak traffic hours at areas with wired WIU communication: short failure duration
5.02	Comm Backbone	High	Comm backbone failure during peak traffic hours at areas with wired WIU communication: long failure duration

4.3 Selected Scenarios

The shaded rows in the above table are the scenarios selected for the case study analysis. The research team selected a limited number of scenarios to focus on the ones of greatest interest. In general, an outage, regardless of cause, compels affected trains to transition to a fallback mode of operation. The number of affected trains and the duration of the outage will vary by incident and type of incident. The “high” duration scenarios are of greater interest than “low” duration. The two selected “train” category scenarios directly impact a single train, while the “back office” and “base station” selected scenarios affect multiple trains. The team believes that the focus on a limited number of scenarios provided a clearer presentation of the CFIM model capabilities.

The following is a brief description of each of the selected scenarios. Each scenario simulated three days of operations. The starting simulation day, day 0, was a warmup day with no events.

4.3.1 1.02 Train Failures – Long

This scenario analyzes the effects of train originating CFIM incidents with long restore times. On day 1, one train experienced a human error with PTC enforcement, with a restore time between 20 and 30 minutes, and a second train experienced a software defect with a restore time between 120 and 180 minutes. On day 2, one train experienced an onboard failure and another a PTC disengagement, both with a restore time between 120 and 180 minutes.

4.3.2 1.03 Train Failures – Unrecoverable

This scenario analyzed the effects of train-originating CFIM incidents that were unrecoverable. On day 1, one train experienced a human error with PTC enforcement, and another had a software defect. On day 2, one train experienced an onboard failure and another a PTC disengagement. All events in this simulation were unrecoverable, and trains continued to their destination following the applicable PTC Fallback Mode restrictions.

4.3.3 3.02 Base Station Failures – Long

This scenario analyzed the effects of Base Station CFIM incidents. On day 1, two base stations in Ft. Worth (i.e., Ft. Worth and Saginaw) and two base stations in Red Rock (i.e., Oklahoma City and Paoli) failed at high-traffic times for their respective locations. On day 2, two base stations in Wichita Falls (i.e., Jolly and Decatur) failed. All base station failures in this case were restored within 3 to 3 1/2 hours.

4.3.4 4.02 Back Office Failures – Long

This scenario analyzed the effects of Back Office failure CFIM incidents against the baseline simulation. On day 1, the Ft. Worth and Red Rock back offices failed at 2:00 p.m. and 6:00 p.m., respectively. On day 2, the Wichita Falls back office failed at 3:00 a.m. Both failure events were restored within 3 to 3 1/2 hours.

5. Findings

Appendix A contains the stringline charts for each of the five simulations:

- Baseline (no comm events)
- Scenario 1.02 Onboard Recoverable Failures – each failure impacted a single train, which proceeded in fallback mode for a limited duration.
- Scenario 1.03 Onboard Non-Recoverable Failures – each failure impacted a single train, which proceeded in fallback mode from the event until the end of the train’s run.
- Scenario 3.02 Base Station Failures – failures were of limited duration and impacted all trains within the area of the base station.
- Scenario 4.02 Back Office Failures – failures affected all trains in the territory for the duration of the outage (failures manifested as “train failed to synchronize with back office”).

Note in the stringline charts that trains in fallback mode are colored yellow. While the simulations were run for 3 days, the first day was regarded a warm-up day because the team started with an empty track. The charts and analysis were based on the second and third days of simulation only.

In Appendix B, see the speed charts for representative trains.

Figure 5-1 shows the stringline for Scenario 3.02. The shaded rectangle is the zoomed-in area from Figure 5-2.

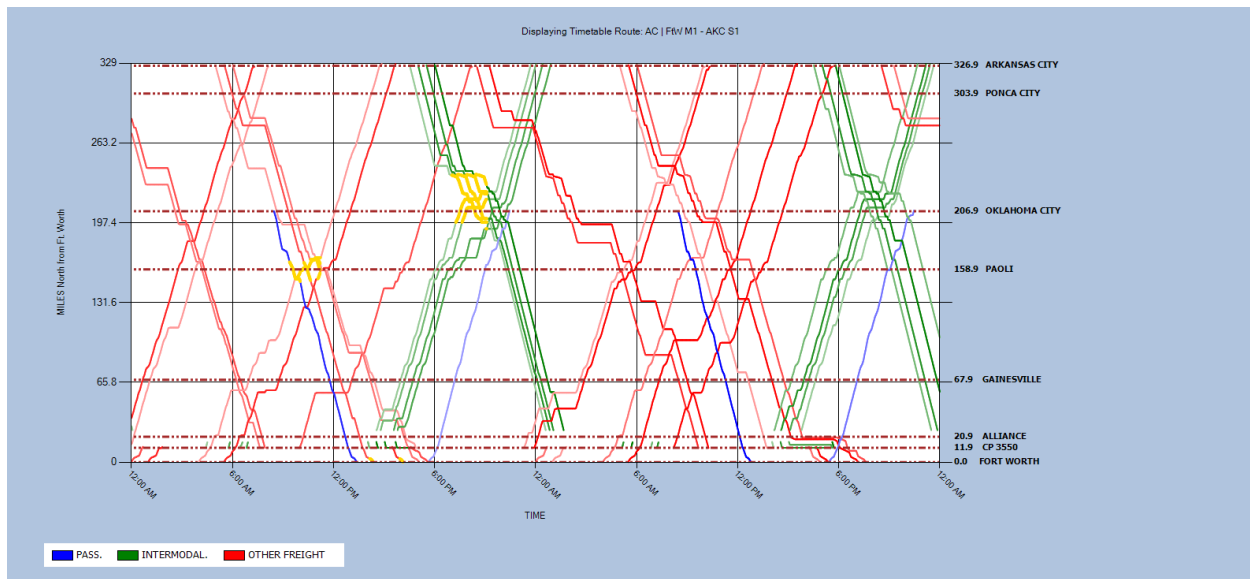

Figure 5-1. Scenario 3.02 Base Station Failures

The stringline shows the impacted trains in fallback mode in yellow. Note that their movement in fallback was slower (i.e., the slope of the stringline is more moderate). In the zoomed-in view notice that the outage duration (i.e., originating near Oklahoma City) was slightly more than 2 hours (from 7 p.m. to just after 9 p.m.).

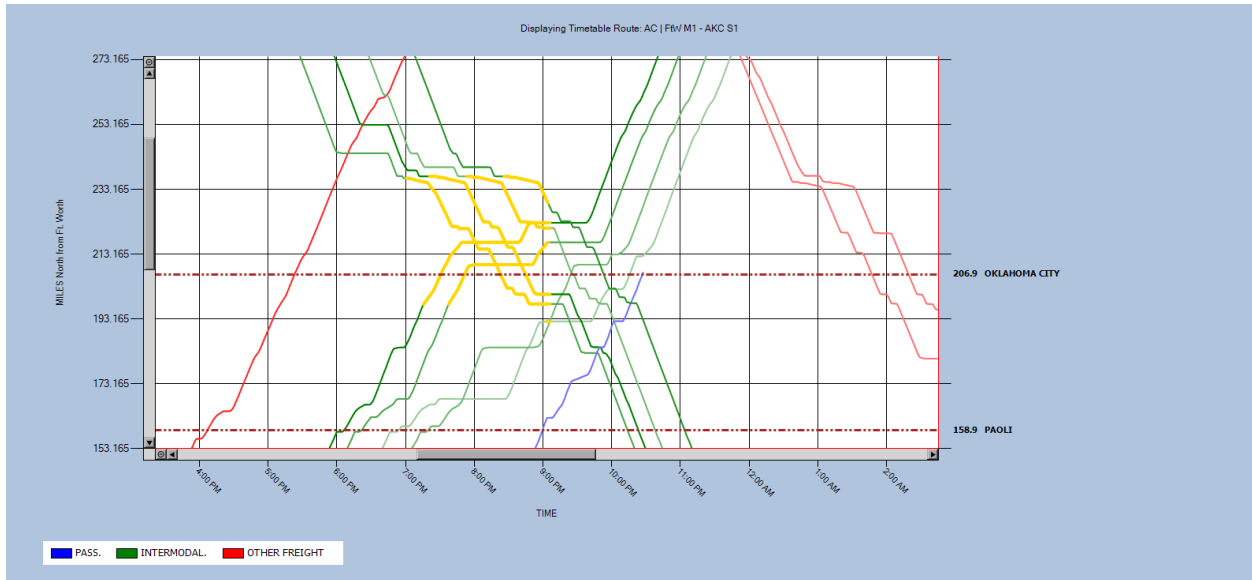

Figure 5-2. Scenario 3.02 Base Station Failures – Zoomed View

The aggregate effects on simulations that had communications failures are presented in [Figure 5-3](#) and [Figure 5-4](#).

The charts and accompanying tables ([Table 5-1](#) and [Table 5-2](#)) show that the effect of the injected failures was not categorical for all train types. This can be explained by examining the stringlines and noting that when trains were slowed in one end of the territory, it created opportunities for accelerated movement at the other end.

Also, each scenario contained failures of a certain type. Some types affected only a single train, while others impacted trains bounded by a time and location window. In the case of back office failures, all trains were impacted.

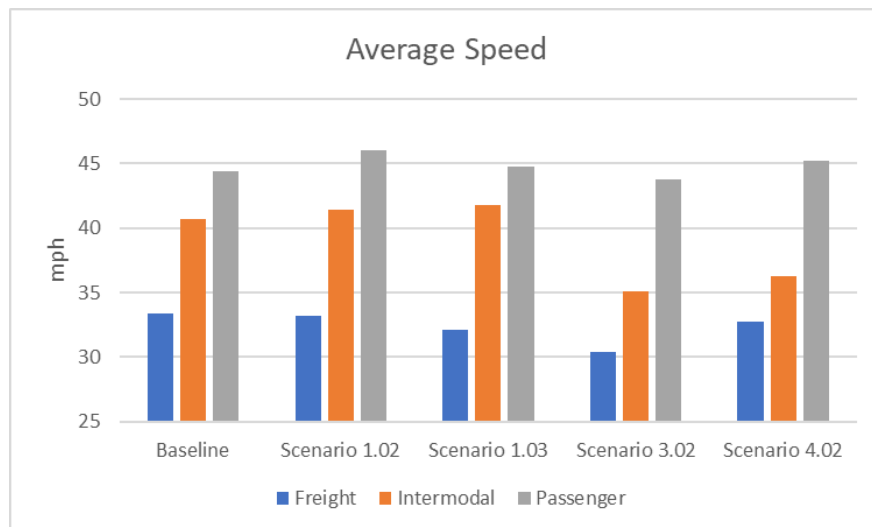

Figure 5-3. Scenario Results – Average Speeds

Table 5-1. Scenario Results – Average Speeds

Scenario	Train Types		
	Freight	Intermodal	Passenger
	Average Speed (mph)		
Baseline	33.4	40.7	44.4
Onboard Recoverable	33.2	41.4	46.0
Onboard Non-Recoverable	32.1	41.8	44.8
Base Station Failures	30.4	35.1	43.8
Back Office Failures	32.7	36.3	45.2
	Change from Baseline		
Onboard Recoverable	-0.6%	1.7%	3.6%
Onboard Non-Recoverable	-3.9%	2.7%	0.9%
Base Station Failures	-9.0%	-13.8%	-1.4%
Back Office Failures	-2.1%	-10.8%	1.8%

Shaded cells in table indicate lower average speeds with failure scenario than baseline.

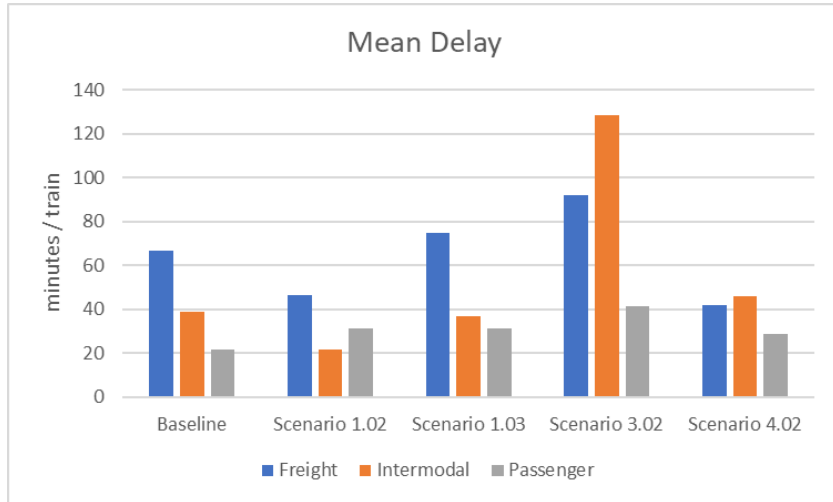

Figure 5-4. Scenario Results – Mean Delay

Table 5-2. Scenario Results – Mean Delay

Scenario	Train Types		
	Freight	Intermodal	Passenger
	Average Delay against Schedule (min)		
Baseline	66.9	39.1	21.6
Onboard Recoverable	46.4	21.4	31.4
Onboard Non-Recoverable	74.8	36.6	31.3
Base Station Failures	92.2	128.2	41.6
Back Office Failures	41.9	46.1	28.7
	Change from Baseline (min)		
Onboard Recoverable	-20.5	-17.7	9.8
Onboard Non-Recoverable	7.9	-2.5	9.7
Base Station Failures	25.3	89.1	20.0
Back Office Failures	-25.0	7.0	7.1

Shaded cells indicate greater mean delay with failure scenario than baseline.

6. Conclusion

This case study demonstrated the impacts of select communication failure scenarios on operational performance using enhanced GTMS software. The impacts were measured as changes in average speed and mean delay for three train types: freight, intermodal and passenger.

In general, average speeds declined, depending on scenario and train type, by between 0.60 percent to as much as 13.8 percent. In Scenarios 1.02 and 1.03 there were small speed increases for intermodal and passenger trains.

Mean delay increased for all train types with the base station failures scenario. Delay was slightly reduced for intermodal trains in the non-recoverable onboard failure scenario. There were sizable delay reductions in the recoverable onboard failure scenario for freight and intermodal. Mean delay declined for freight trains in the back office failures scenario.

In general, one might expect that decrease (increase) in average speed will be matched with increase (decrease) in mean delay. This is not always the case because, for example, if the dispatcher holds a train prior to entering the territory it will impact the train's delay (compared with schedule), but it will not impact a train's average speed.

Each scenario focuses on a specific type of failure. Each type of failure affects single or multiple trains. Moreover, the geographic and time scope of impacted trains varies by failure type, and, as well, by the specific parameters of a scripted failure.

Another factor affecting system-wide performance is that while an outage may slow individual trains, or trains in a particular area for some period of time, it also creates opportunities for other trains in other parts of the territory to advance more rapidly (i.e., trains not directly impacted by comm failures will receive movement authorities sooner in order to fill idle capacity).

7. References

- AAR-ITC Specification S-9503, Subdivision File Specification
- American Railway Engineering and Maintenance of Way Association, Communications and Signals Manual
- Brousseau, J., Moore Ede, B., Pate, S., Wiley, R. B., Drapa, J. “[Development of an Operationally Efficient PTC Braking Enforcement Algorithm for Freight Trains.](#)” Technical Report No. DOT/FRA/ORD-13/34, Washington, DC: U.S. Department of Transportation, Federal Railroad Administration, 2013.
- Transportation Technology Center, Inc. (TTCI) Report “Railroad Network Simulator Requirements for the Higher Reliability and Capacity Train Control Project,” April 2017
- U.S. Government Publishing Office, “[Railroad Locomotive Safety Standards,](#)” Federal Register, Title 49 Code of Federal Regulations Part 229, Washington, DC: U.S. Department of Transportation, Federal Railroad Administration, 2010.
- U.S. Government Publishing Office, “[Grade Crossing Signal System Safety,](#)” Federal Register, Title 49 Code of Federal Regulations Part 234, Washington, DC: U.S. Department of Transportation, Federal Railroad Administration, 2010.
- U.S. Government Publishing Office, “[Instructions Governing Applications for Approving of a Discontinuance or Material Modification of A Signal System or Relief from the Requirements of Part 236,](#)” Title 49 Code of Federal Regulations Part 235, et al. Positive Train Control Systems; Final Rule, 2010.
- I-ETMS PTC Development Plan, v3.1
- “GTMS Communications Model Design Specification Document”, Decisiontek for FRA, July 2018 (updated January 2021)
- “GTMS Users’ Manual”, Decisiontek for FRA, January 2021

Abbreviations and Acronyms

ACRONYM	DEFINITION
ABS	Automatic Block Signal
BOS	Back Office System
CD	Central Dispatcher
CTC	Centralized Traffic Control
CFIM	Communications Failure Impact Model
GTMS	Generalized Train Movement Simulator
OBC	Onboard Computer
PTC	Positive Train Control
TSR	Temporary Speed Restriction
TTCI	Transportation Technology Center, Inc.
TWC	Track Warrant Control
WIU	Wayside Interface Unit

Appendix A. Stringline Charts

Timetable Route Ft. Worth – Wichita Falls

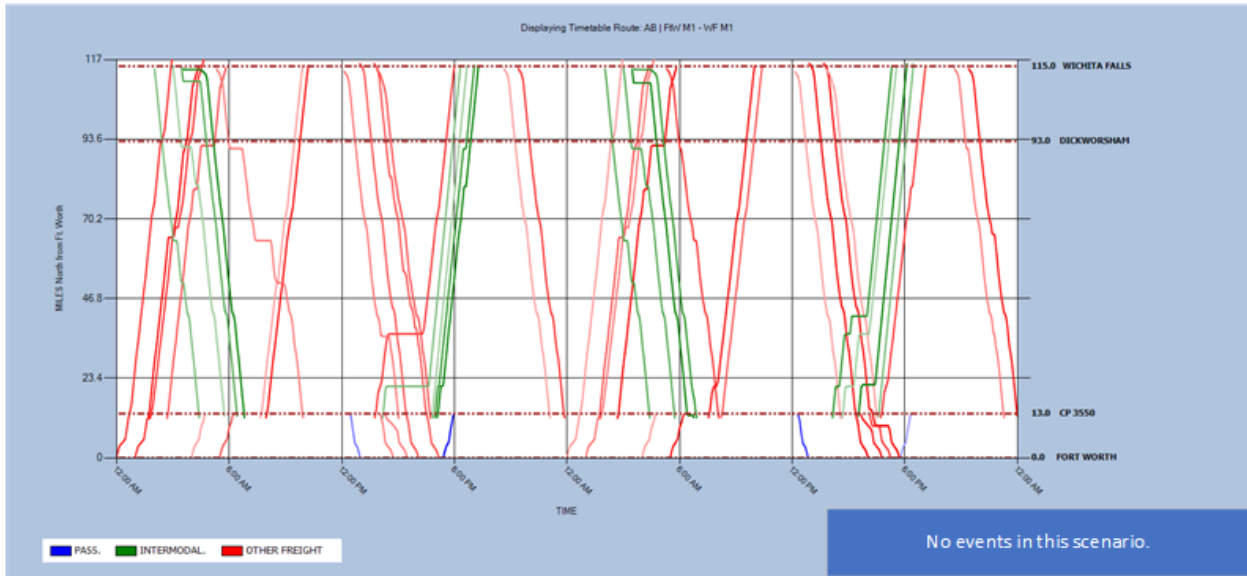

Figure A1. Baseline Scenario (no events)

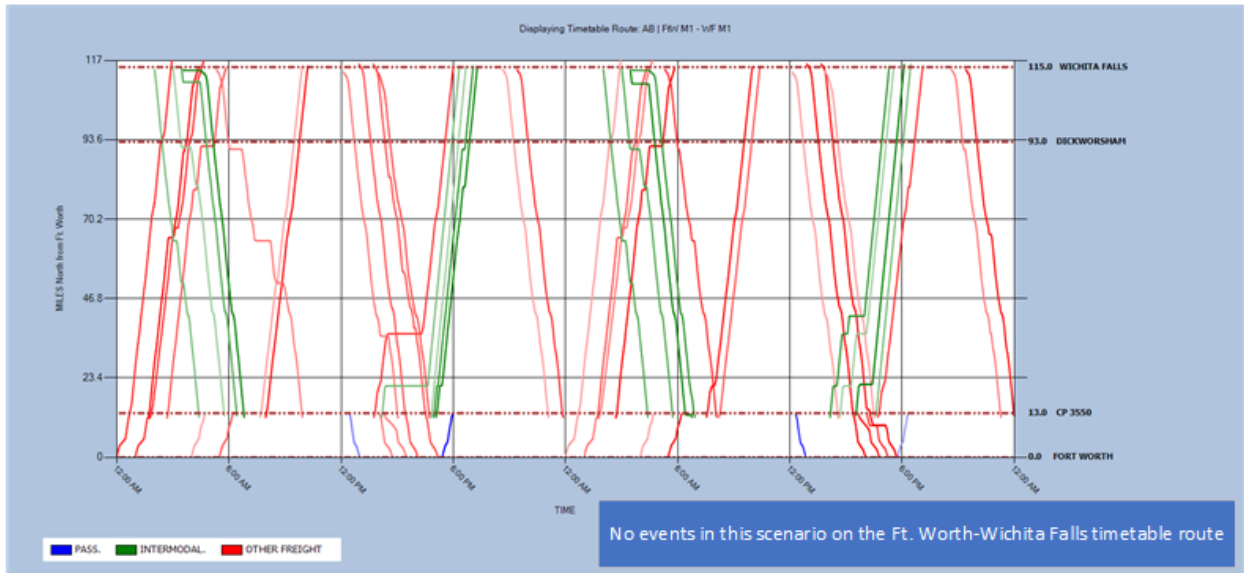

Figure A2. Scenario 1.02 Recoverable Onboard Failures

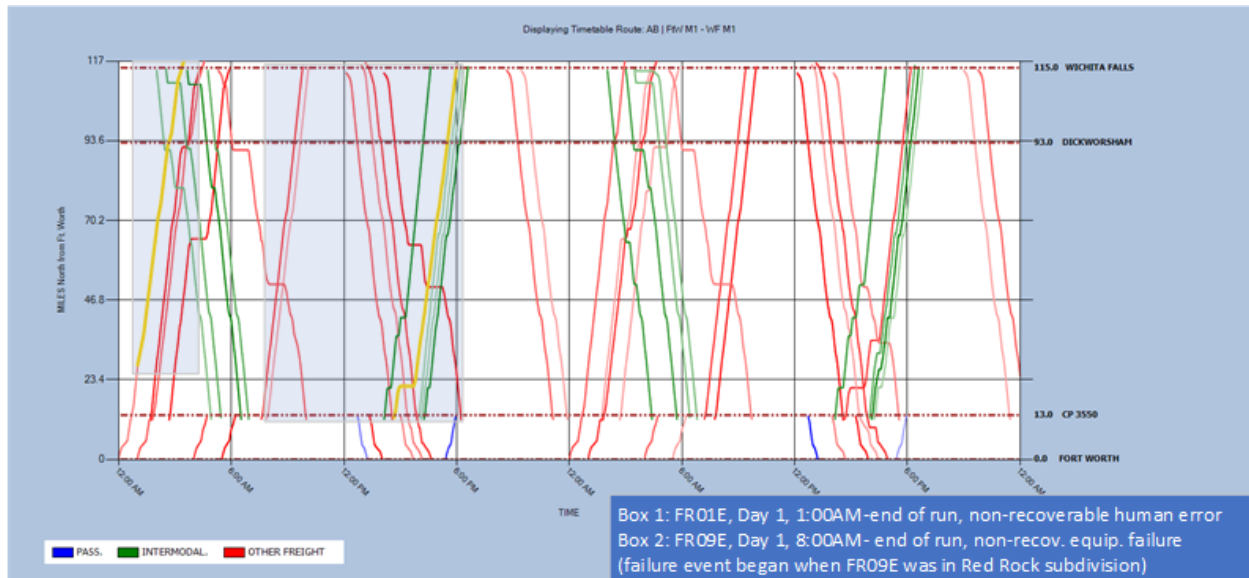

Figure A3. Scenario 1.03 Non-Recoverable Onboard Failures

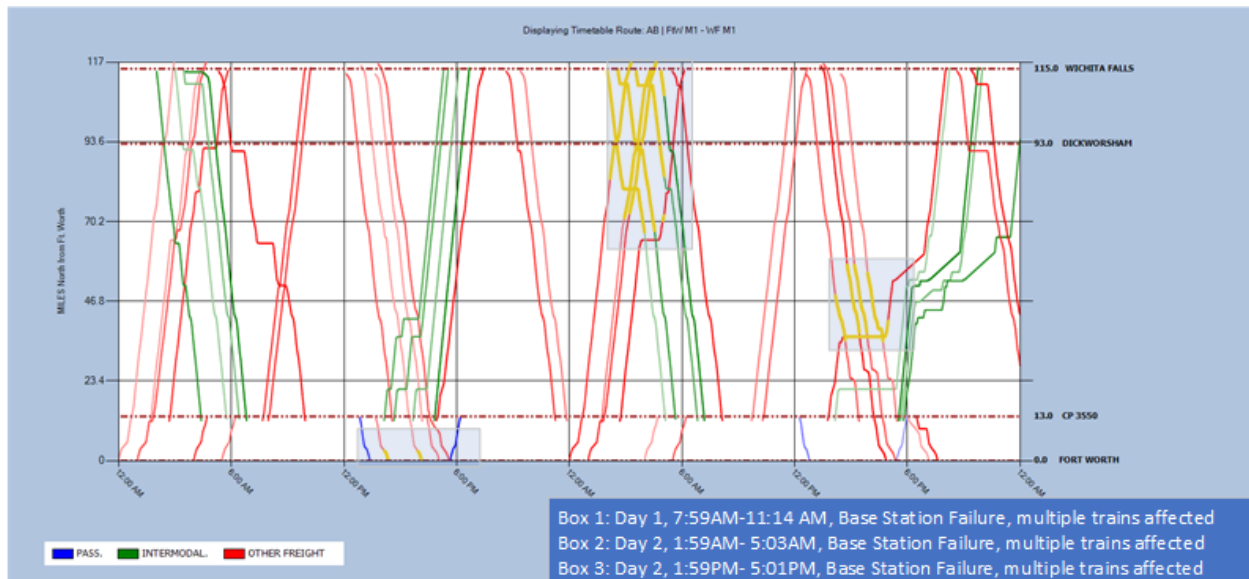

Figure A4. Scenario 3.02 Base Station Failures

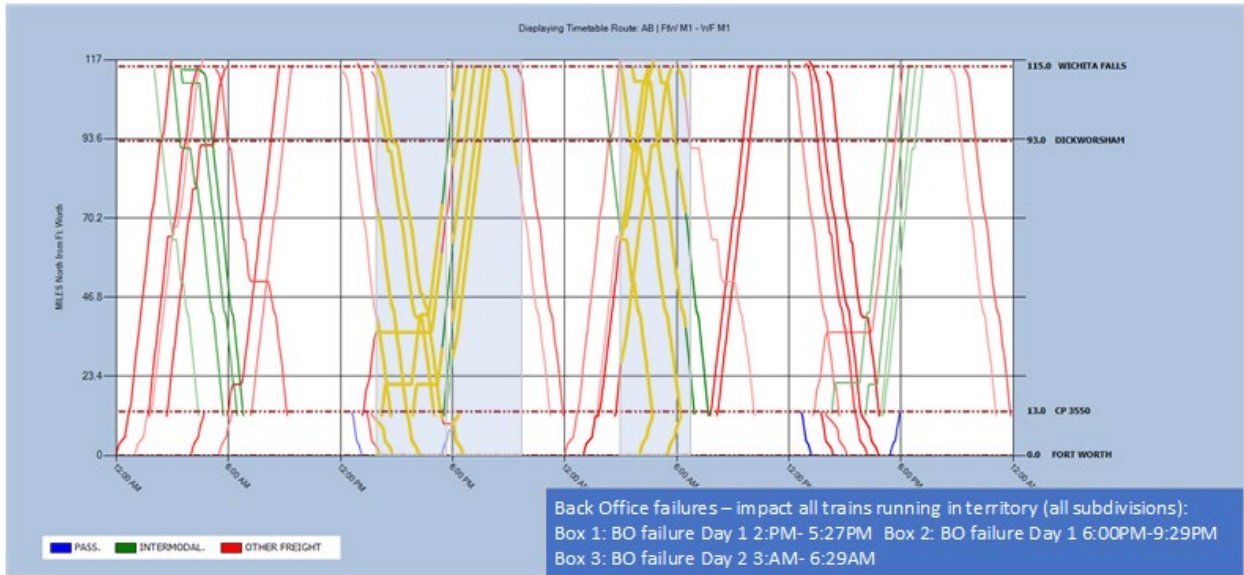

Figure A5. Scenario 4.02 Back Office Failures
 Timetable Route Ft. Worth – Arkansas City

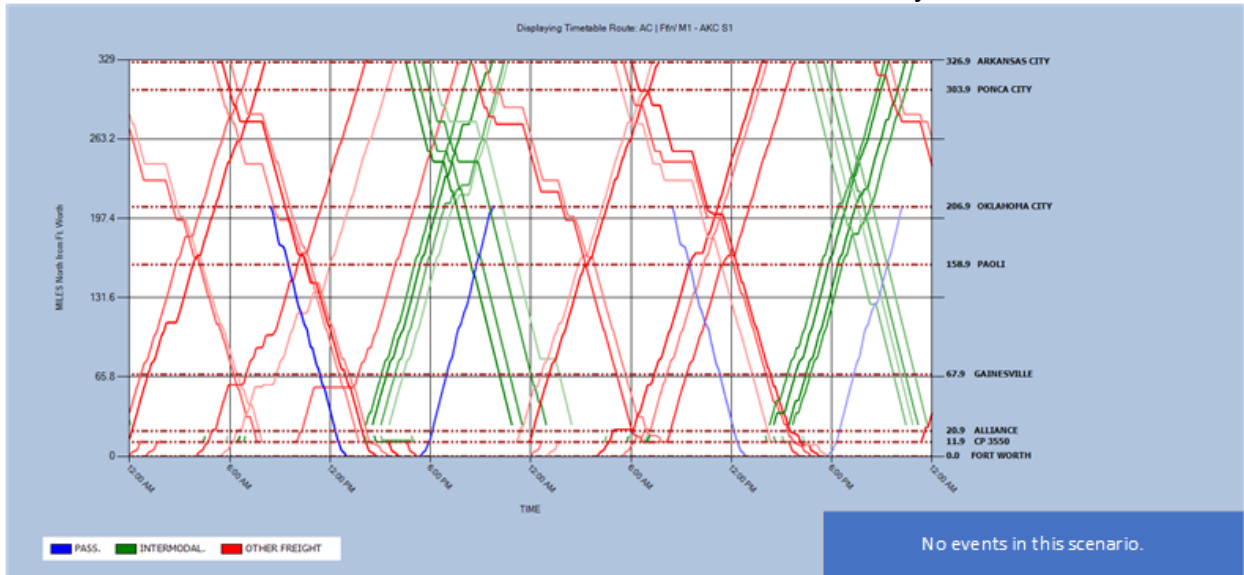

Figure A6. Baseline (no events in this scenario)

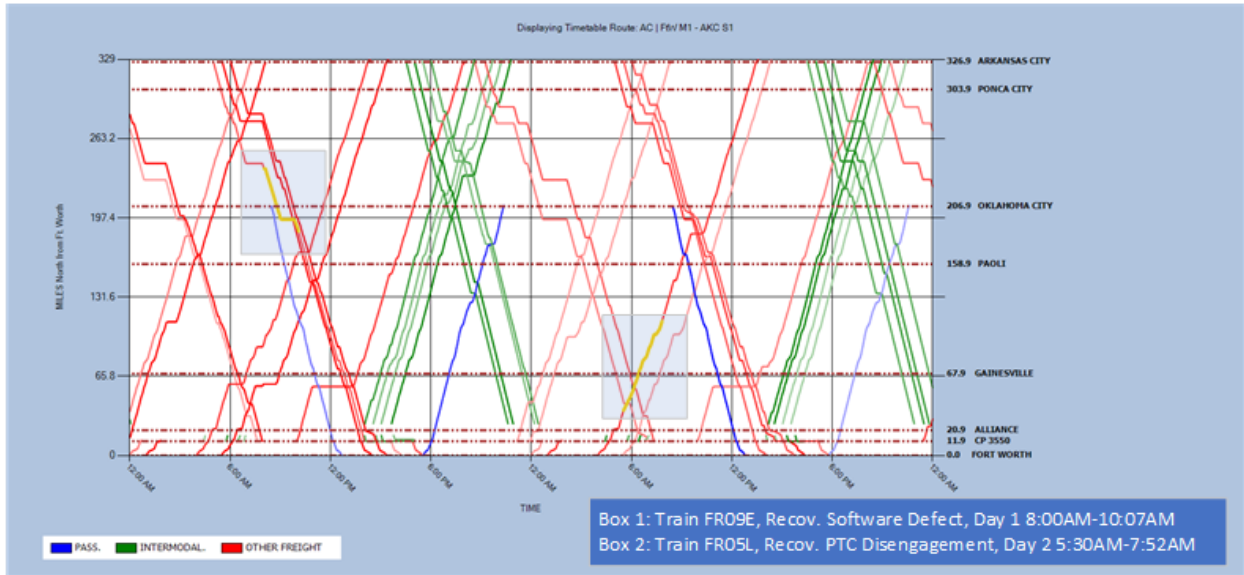

Figure A7. Scenario 1.02 Recoverable Onboard Failures

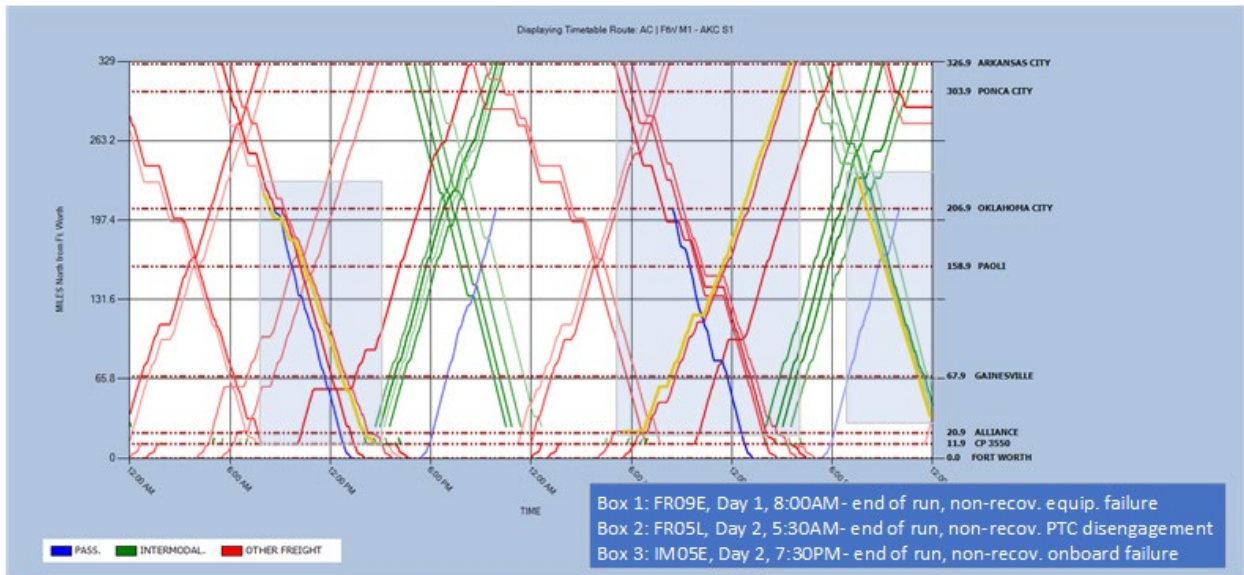

Figure A8. Scenario 1.03 Non-Recoverable Onboard Failures

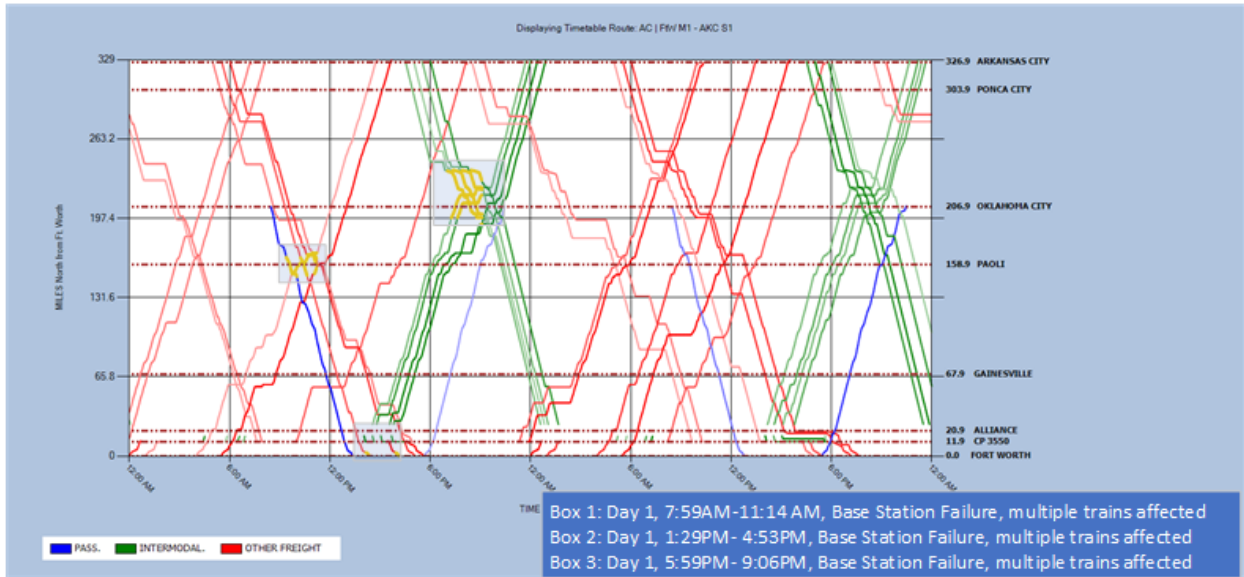

Figure A9. Scenario 3.02 Base Station Failures

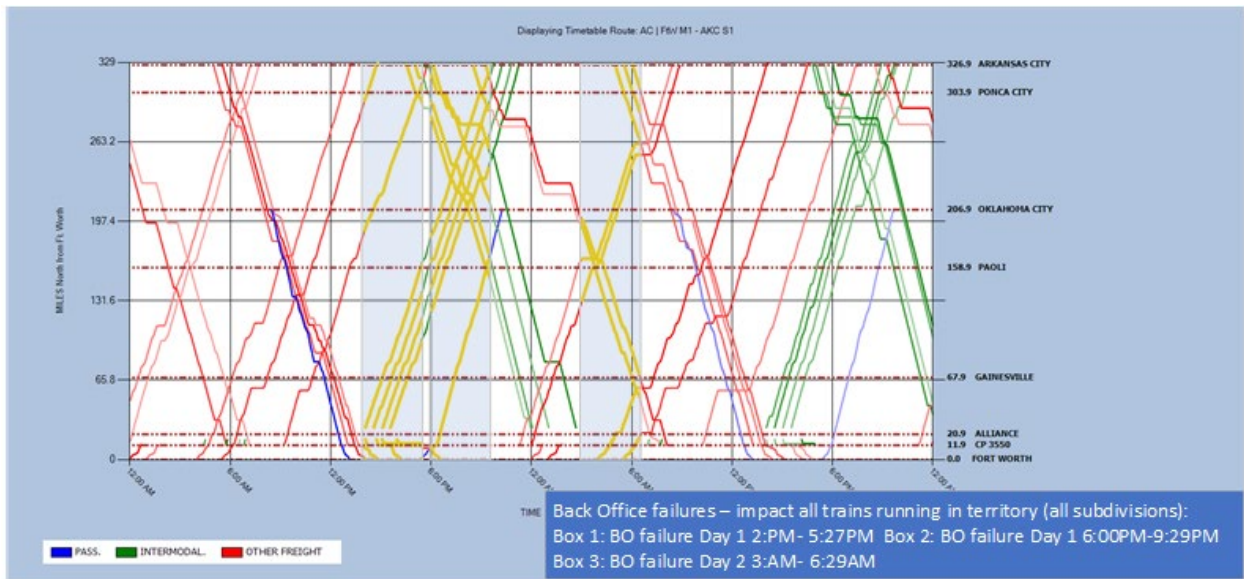

Figure A10. Scenario 4.02 Back Office Failures

Appendix B. Representative Speed Charts

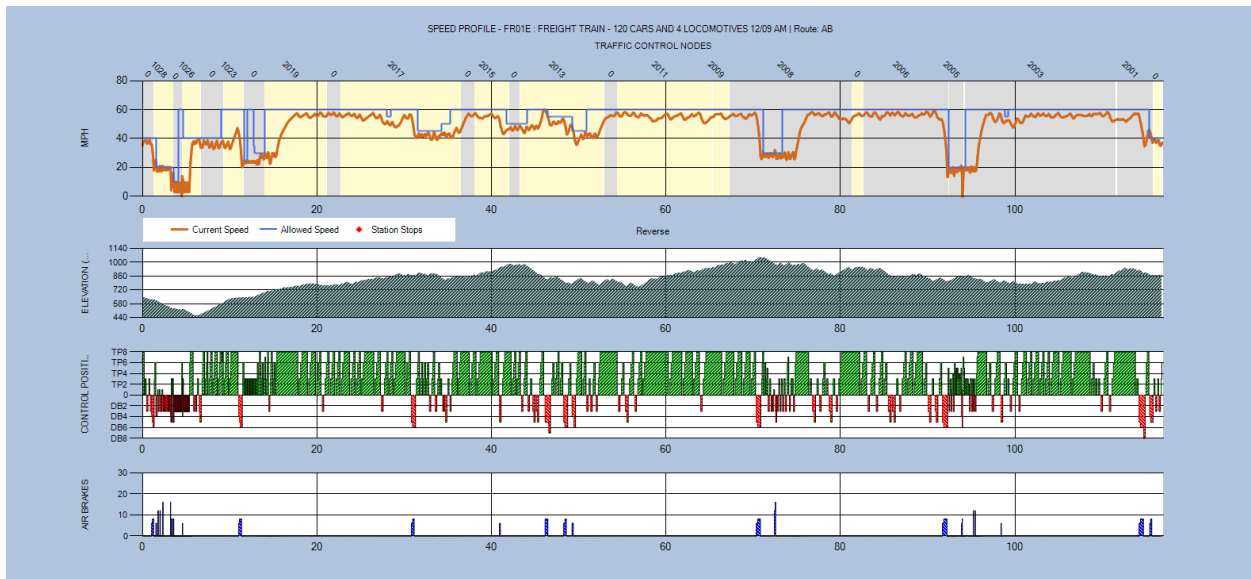

Figure B1. Empty Freight Train – Ft. Worth-Wichita Falls

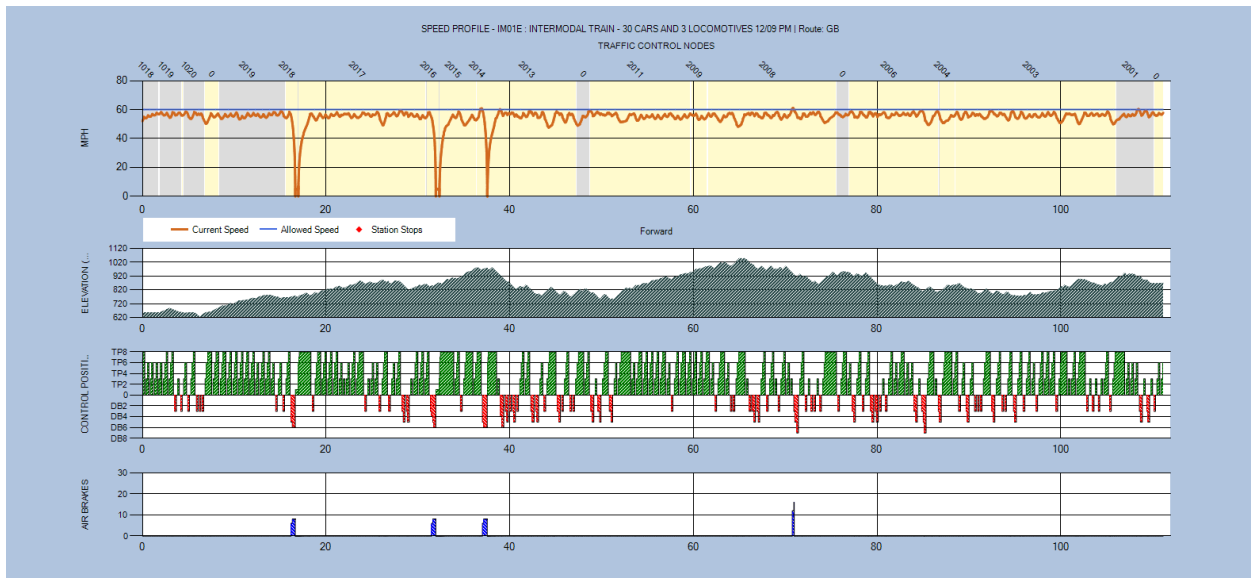

Figure B2. Empty Intermodal Train – Alliance-Wichita Falls

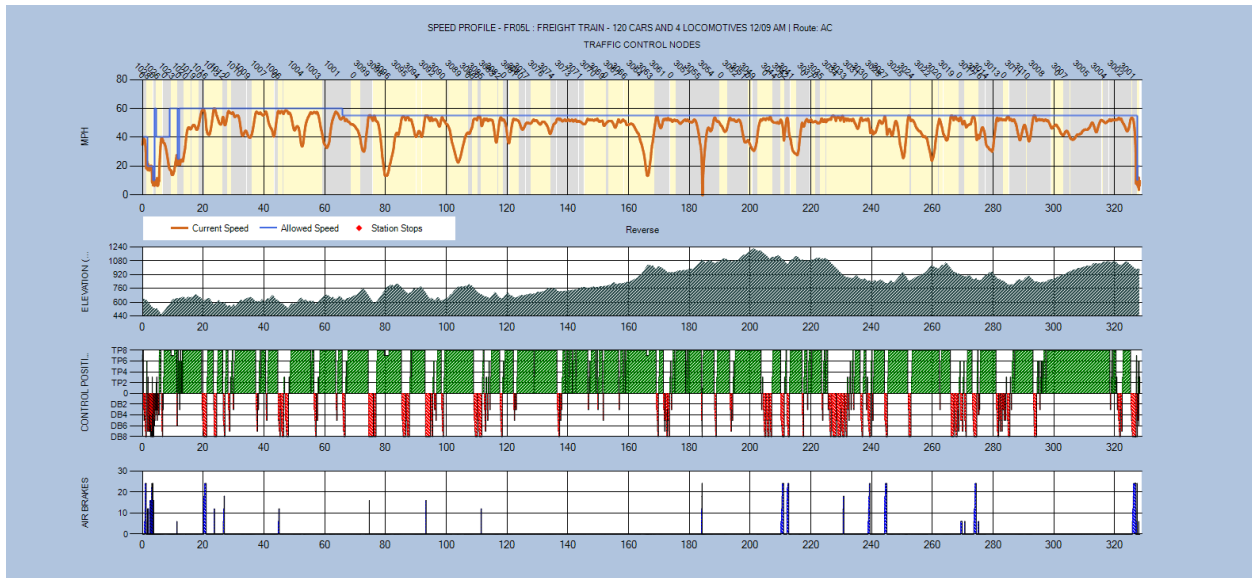

Figure B3. Loaded Freight Train – Ft. Worth-Arkansas City

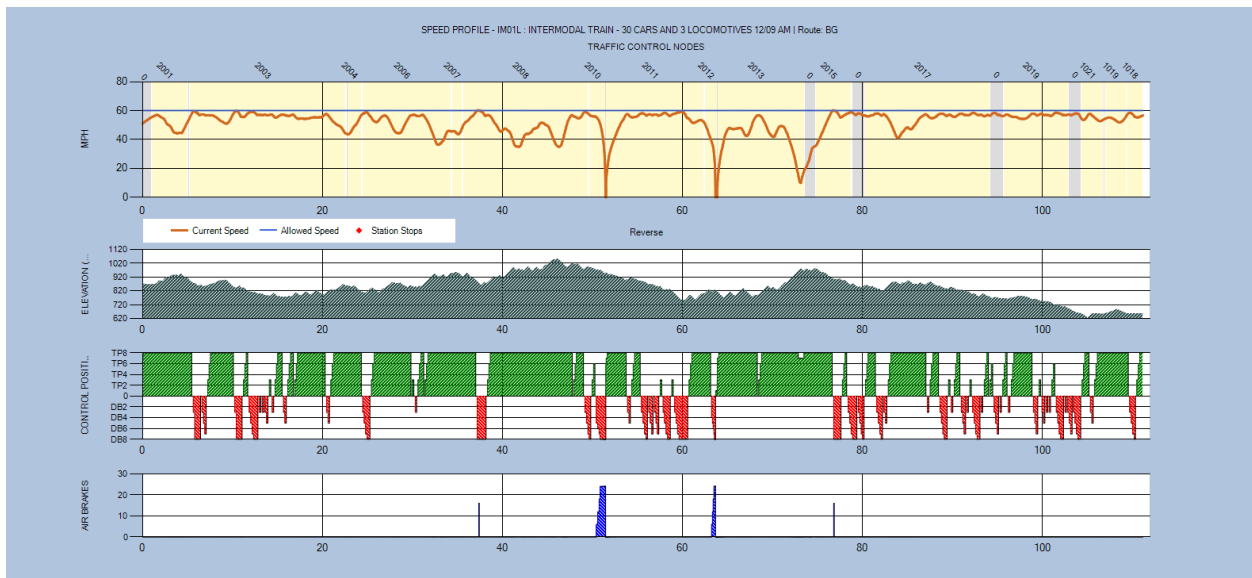

Figure B4. Loaded Intermodal Train – Wichita Falls-Alliance

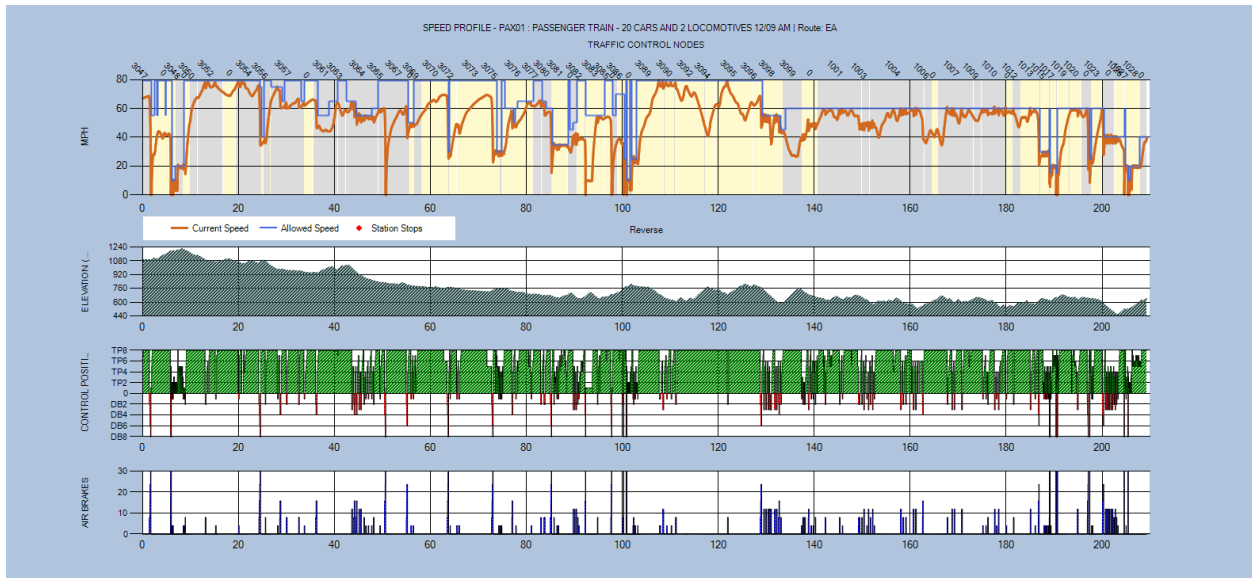

Figure B5. Passenger Train – Oklahoma City-Ft. Worth

Appendix C. Track Charts of Territory

This appendix contains the GTMS-generated track chart images of the three BNSF subdivisions in the analysis territory (Ft. Worth North, Wichita Falls, Red Rock). The core data for the track charts were imported from the I-ETMS subdivision files of the territory.

The track chart displays information for the following types of data (from bottom to top): running (track) distance, grades and elevations, the track (blocks and switches), curves and headings, and speed restrictions.

- Speeds are for the six train types recognized in the I-ETMS data schema and displayed in the following order: freight, passenger, intermodal, tilt, commuter, high-speed rail passenger.
- Black track indicates track in traffic control blocks. Red track indicates track that lie between clearance points and switches. Operable switches appear in red, and inoperable switches appear in black.
- Vertical lines are milepost markers.
- X markers on the tracks indicate highway-rail grade crossings.

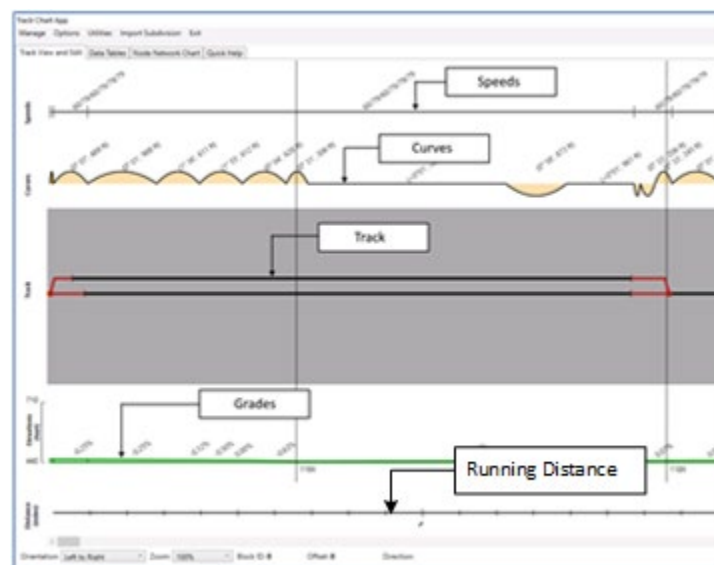

Figure C1. Track Chart Legend

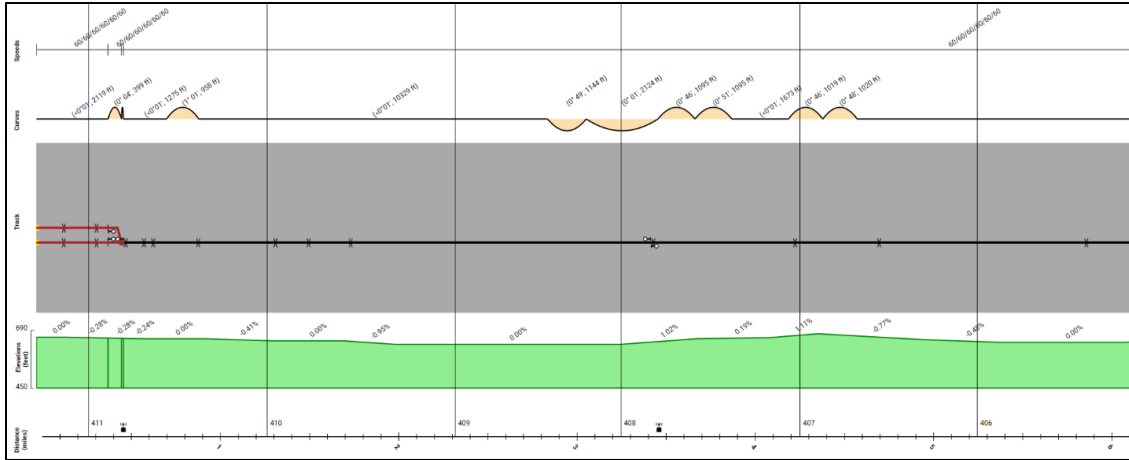

Figure C2. Ft. Worth (North) Subdivision Mile 0-6

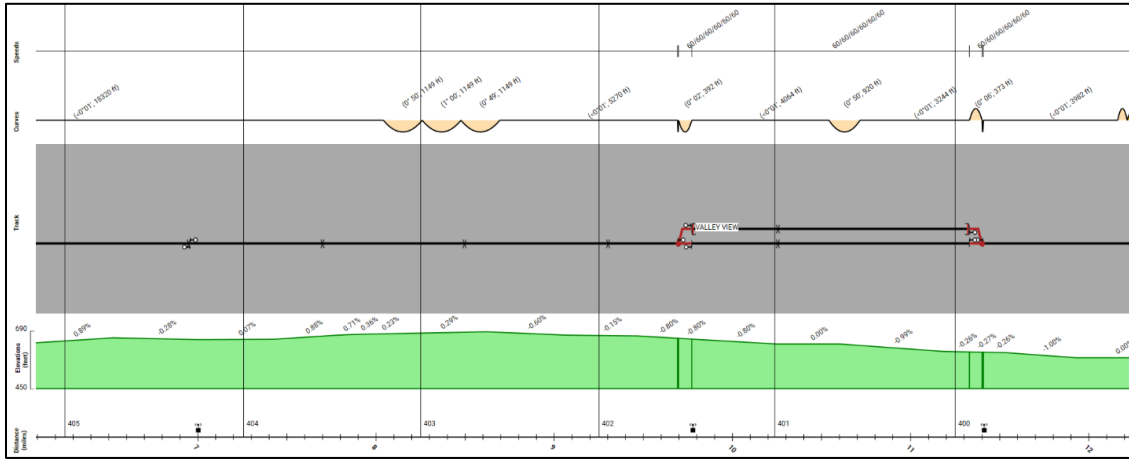

Figure C3. Ft. Worth (North) Subdivision Mile 6-12

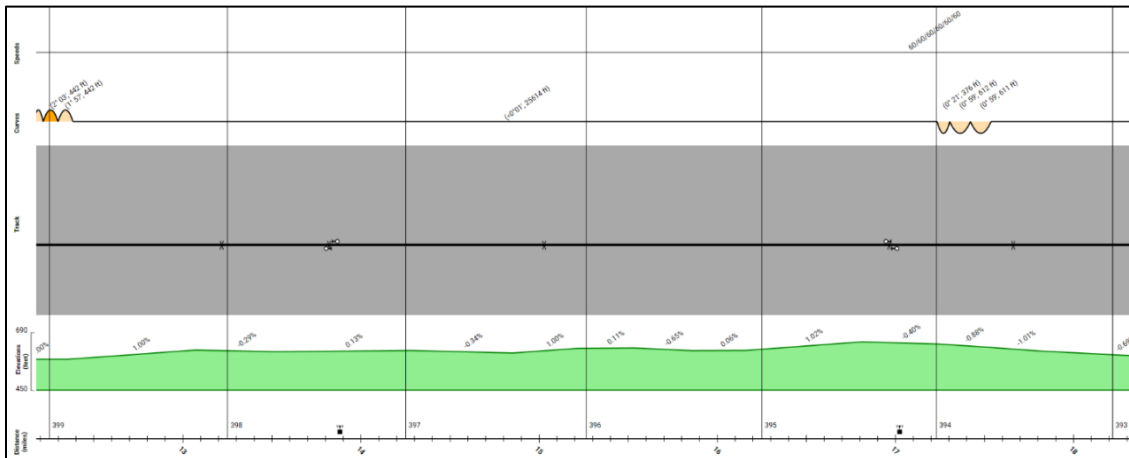

Figure C4. Ft. Worth (North) Subdivision Mile 12-18

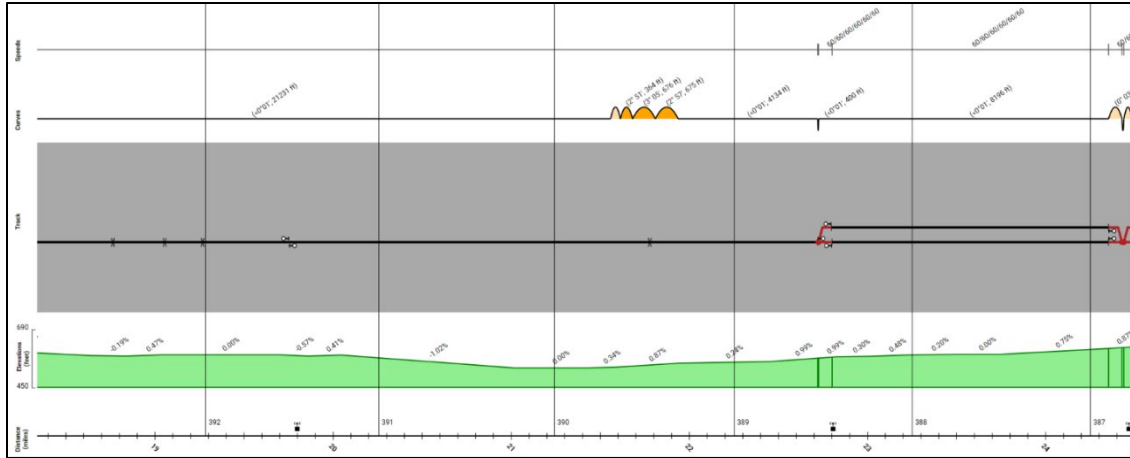

Figure C5. Ft. Worth (North) Subdivision Mile 18-24

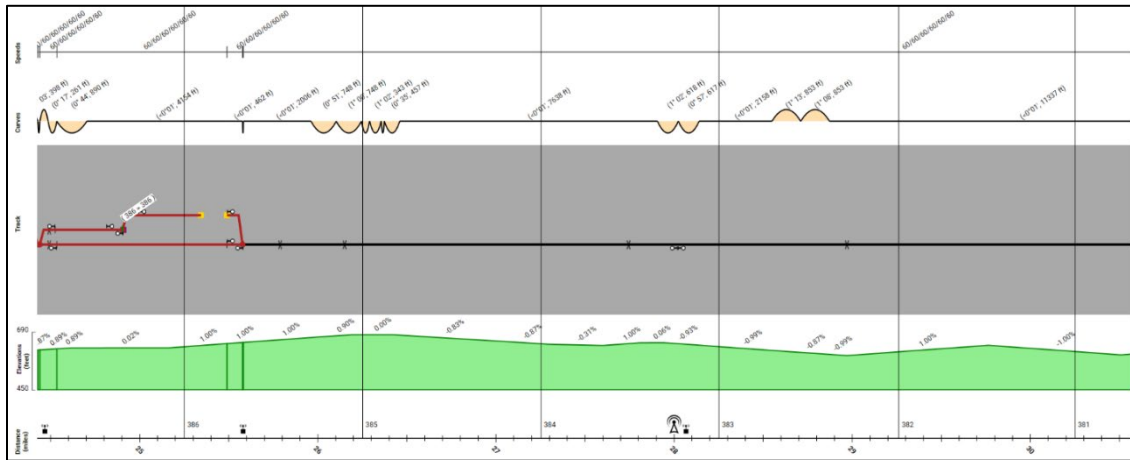

Figure C6. Ft. Worth (North) Subdivision Mile 24-30

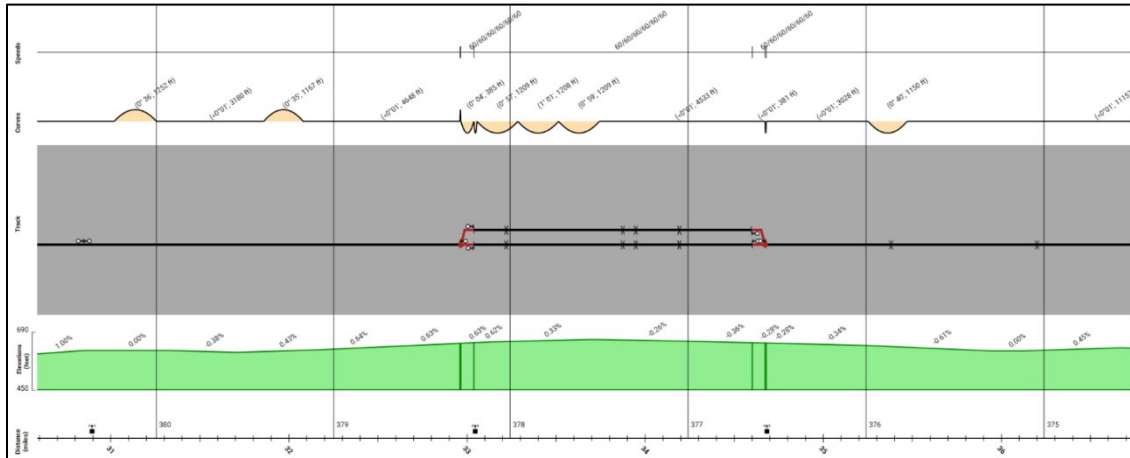

Figure C7. Ft. Worth (North) Subdivision Mile 30-36

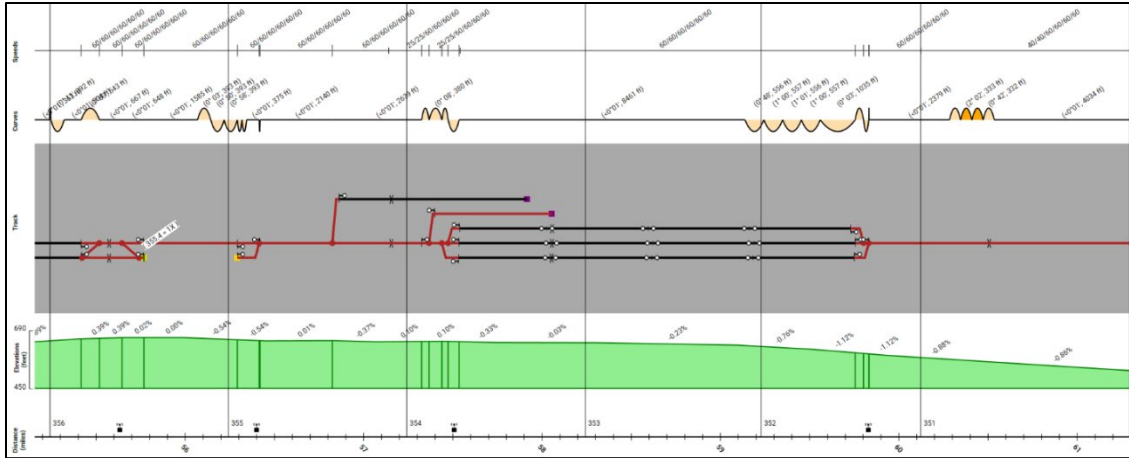

Figure C11. Ft. Worth (North) Subdivision Mile 55–61

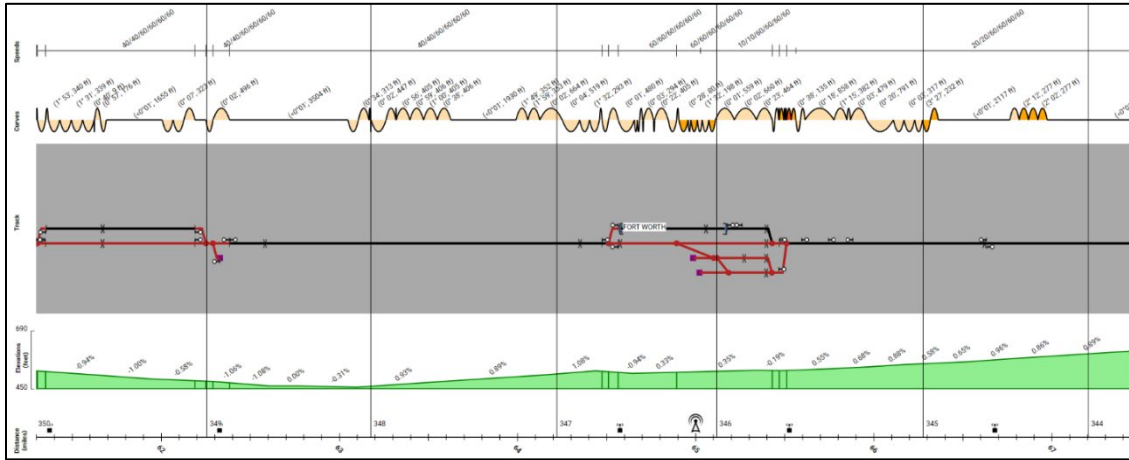

Figure C12. Ft. Worth (North) Subdivision Mile 61–67

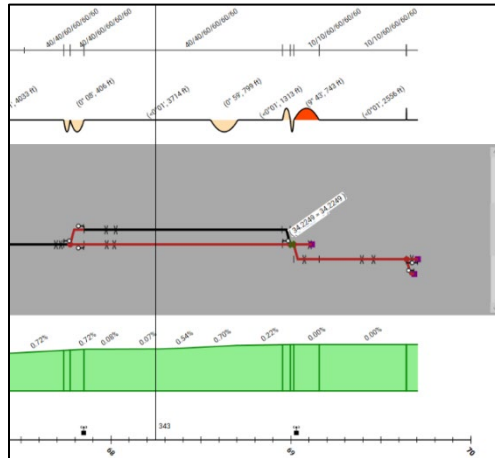

Figure C13. Ft. Worth (North) Subdivision Mile 67–90

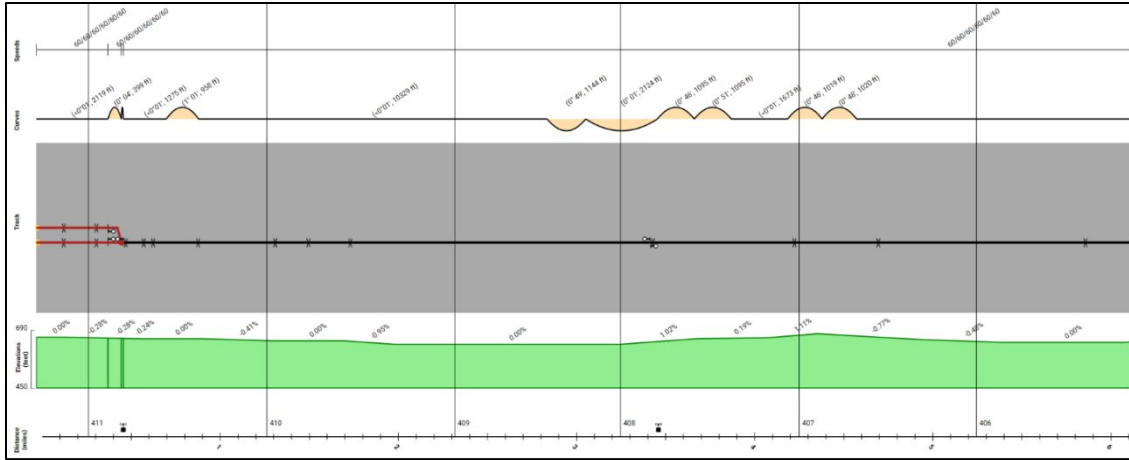

Figure C14. Wichita Falls Subdivision Mile 0–6

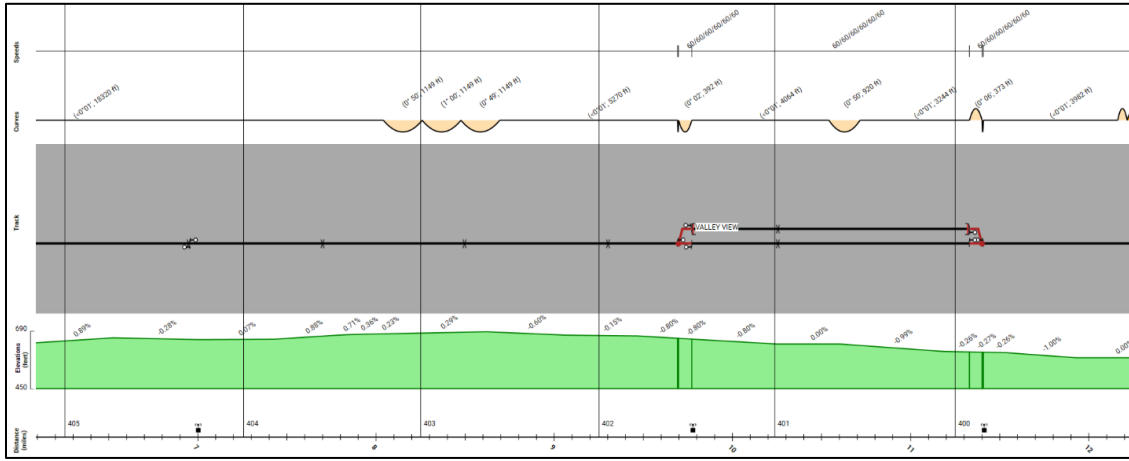

Figure C15. Wichita Falls Subdivision Mile 6–12

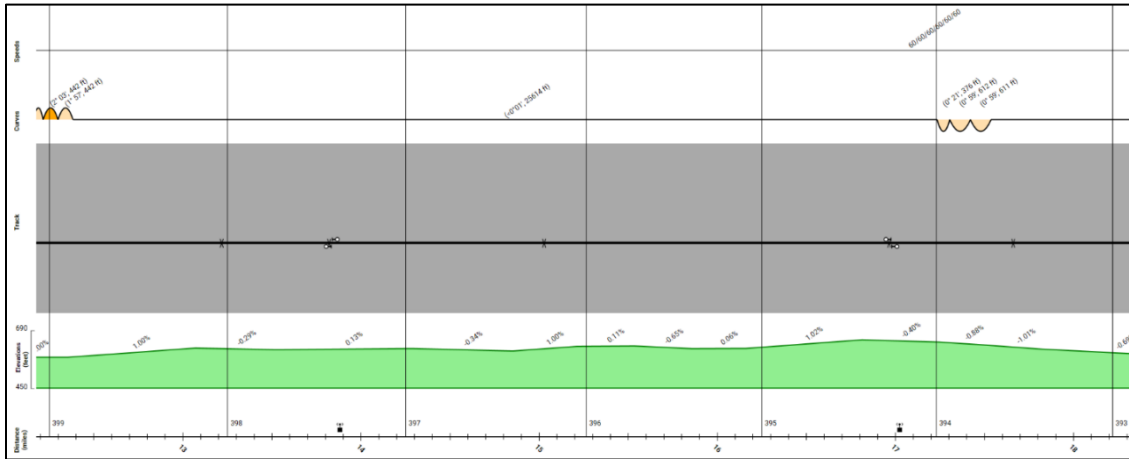

Figure C16. Wichita Falls Subdivision Mile 12–18.3

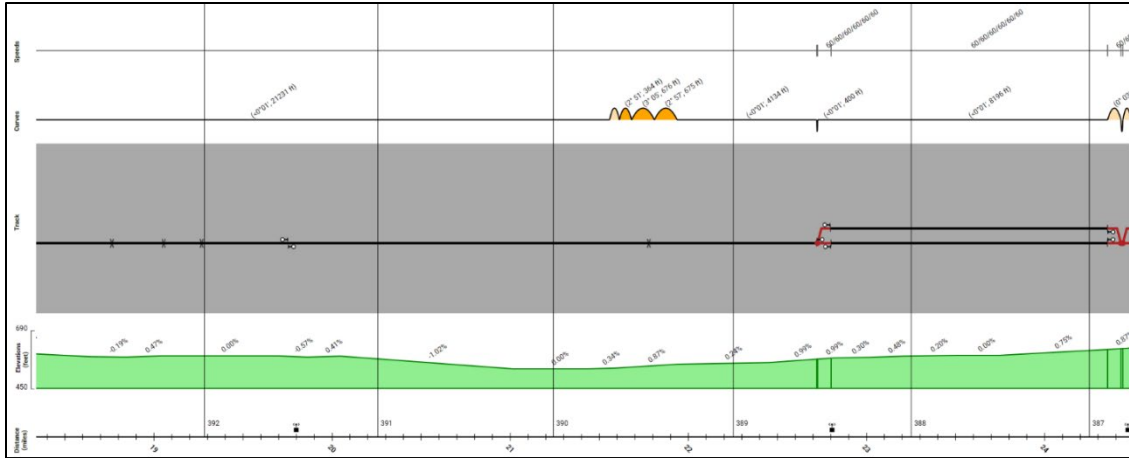

Figure C17. Wichita Falls Subdivision Mile 18.3–24.5

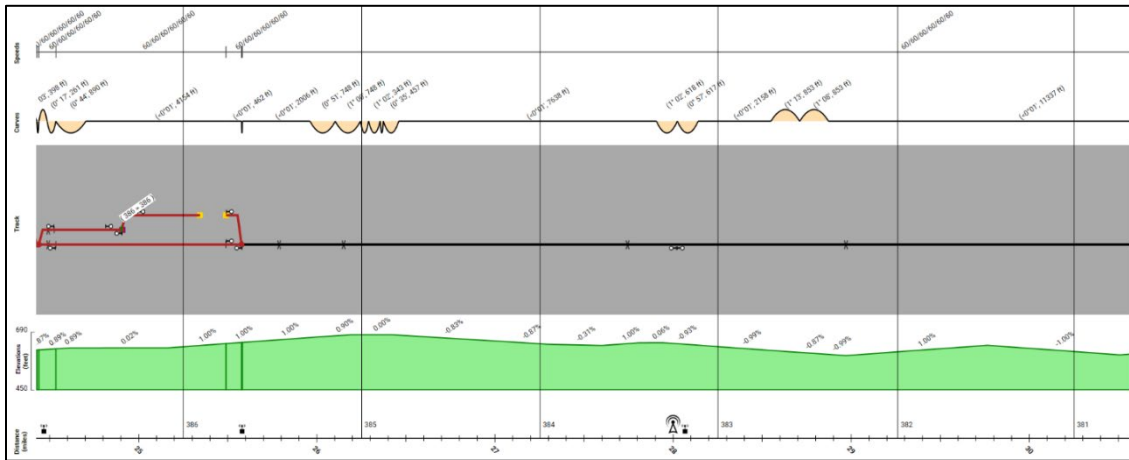

Figure C18. Wichita Falls Subdivision Mile 24.5–30.7

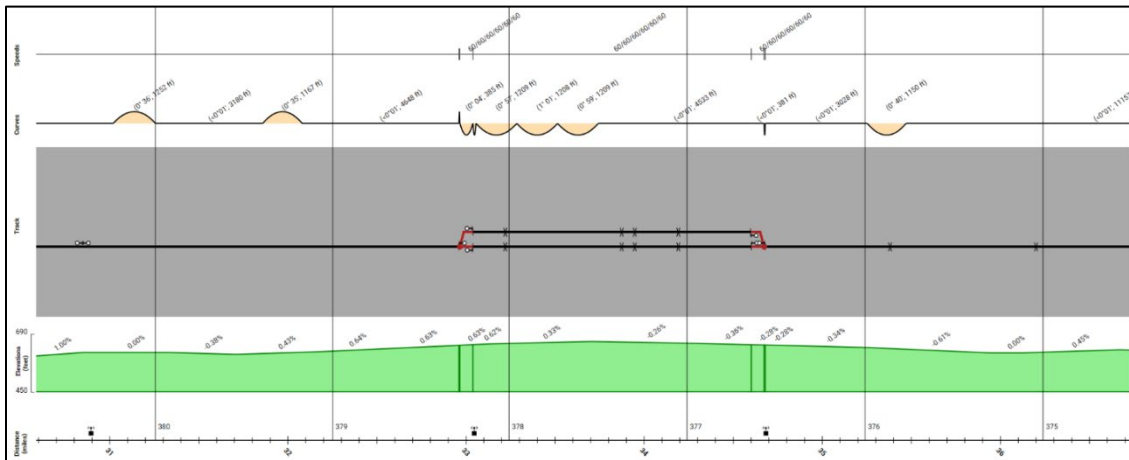

Figure C19. Wichita Falls Subdivision Mile 30.7–36.7

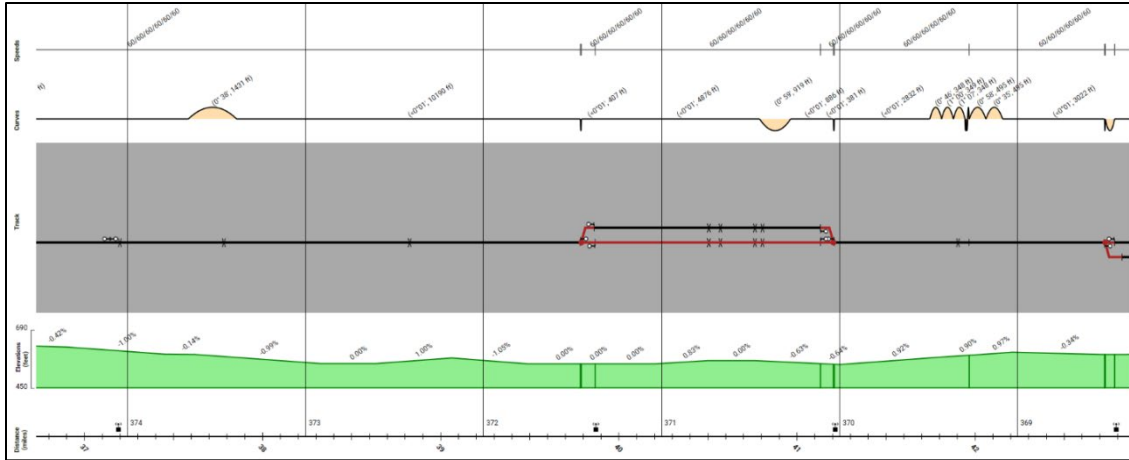

Figure C20. Wichita Falls Subdivision Mile 36.7–42.8

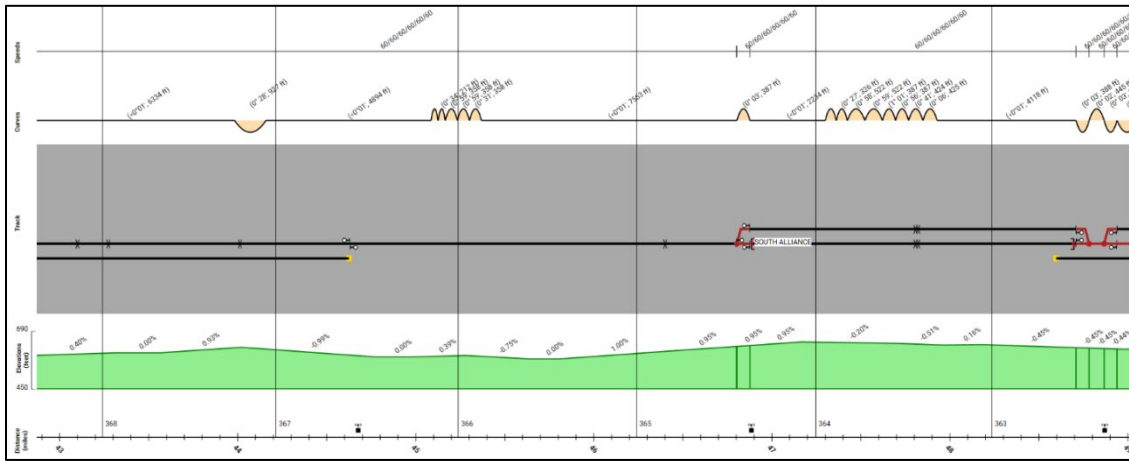

Figure C21. Wichita Falls Subdivision Mile 42.8–49.0

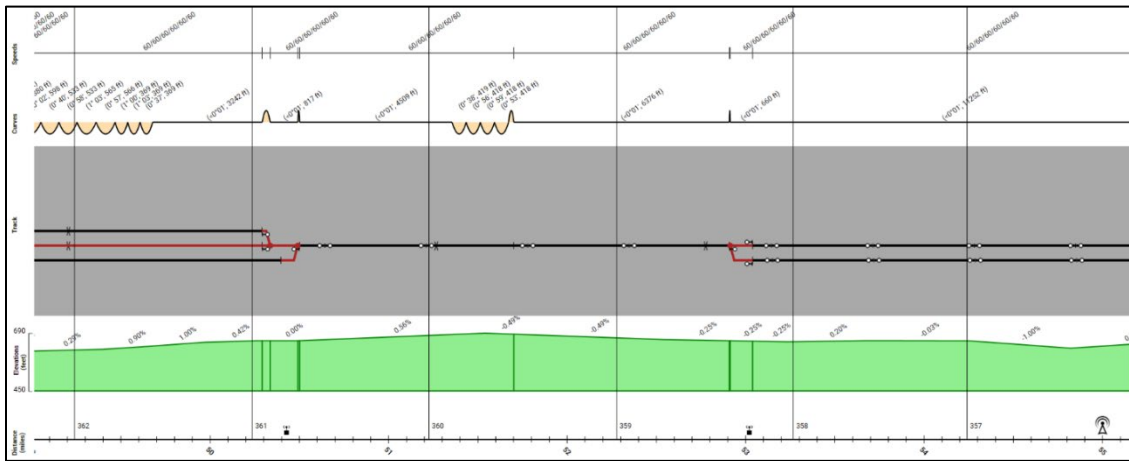

Figure C22. Wichita Falls Subdivision Mile 49.0–55.1

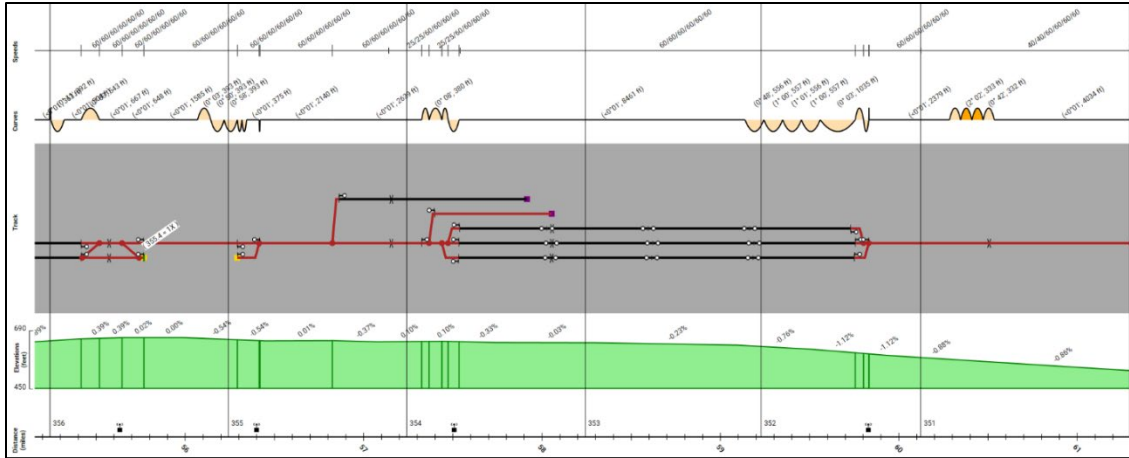

Figure C23. Wichita Falls Subdivision Mile 55.1-61.2

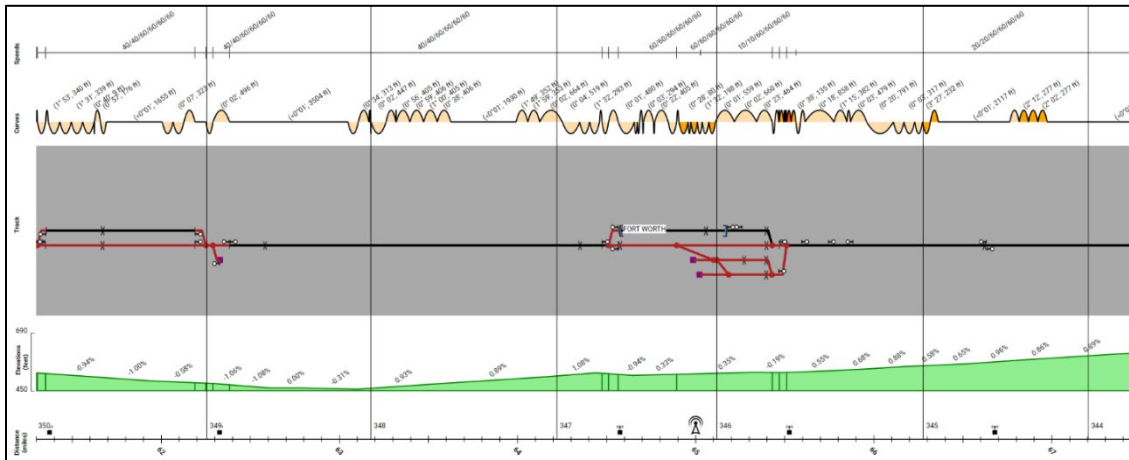

Figure C24. Wichita Falls Subdivision Mile 61.2-67.4

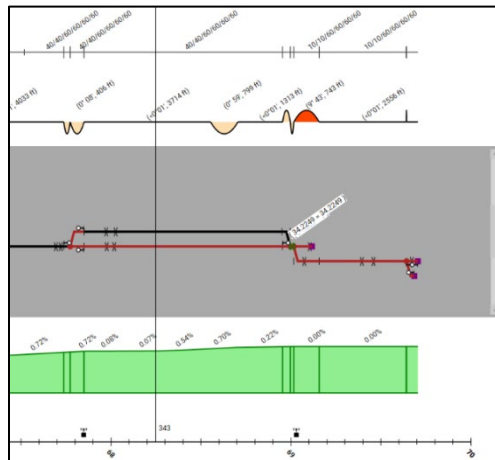

Figure C25. Wichita Falls Subdivision Mile 67.4-69.8

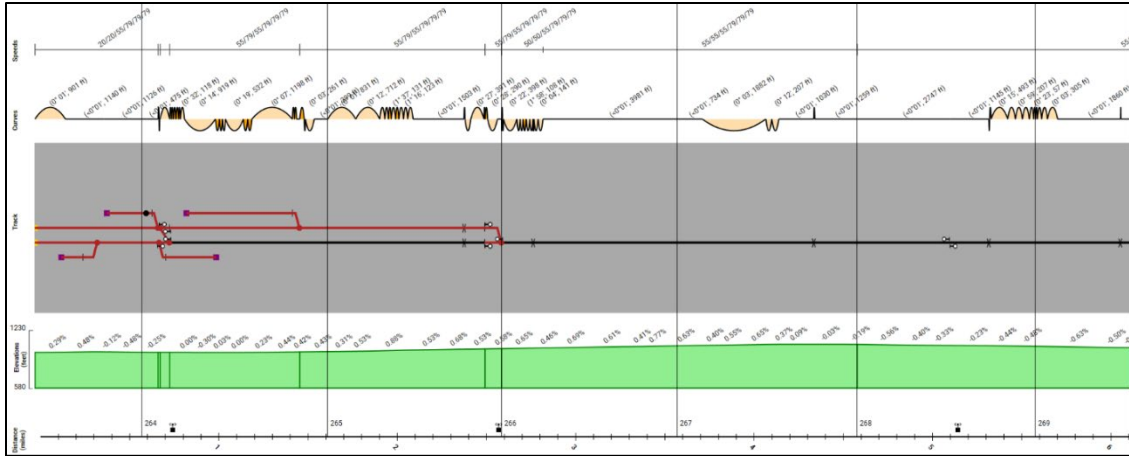

Figure C26. Red Rock Subdivision Mile 0.0-6.1

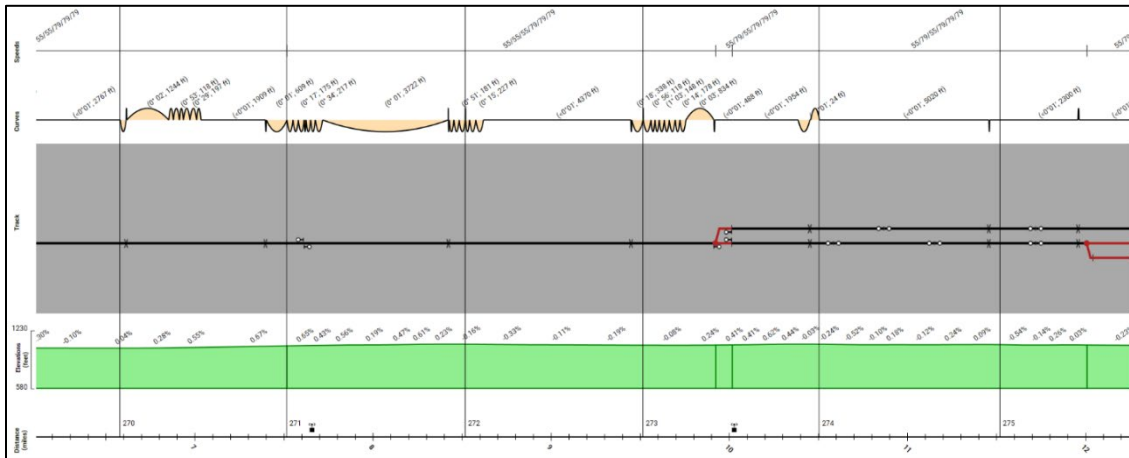

Figure C27. Red Rock Subdivision Mile 6.1-12.2

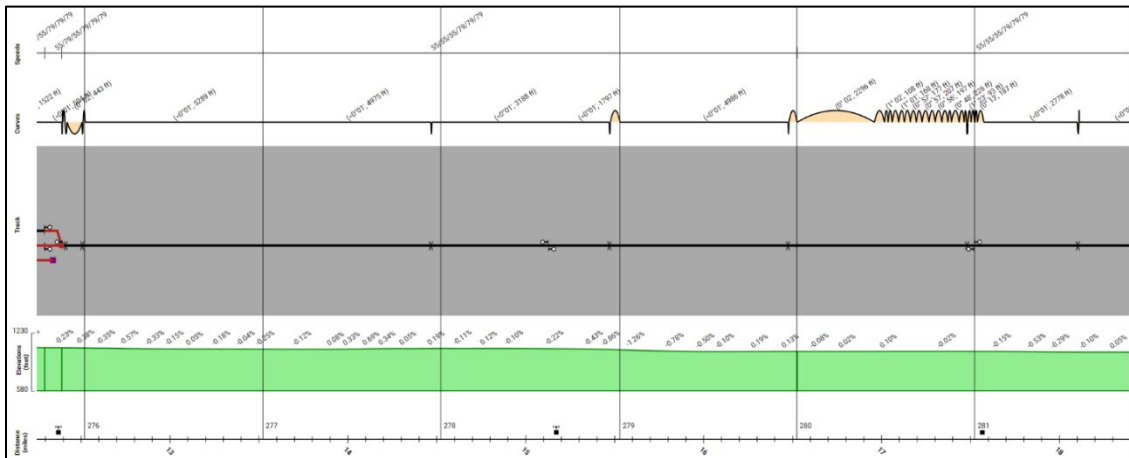

Figure C28. Red Rock Subdivision Mile 12.2-18.3

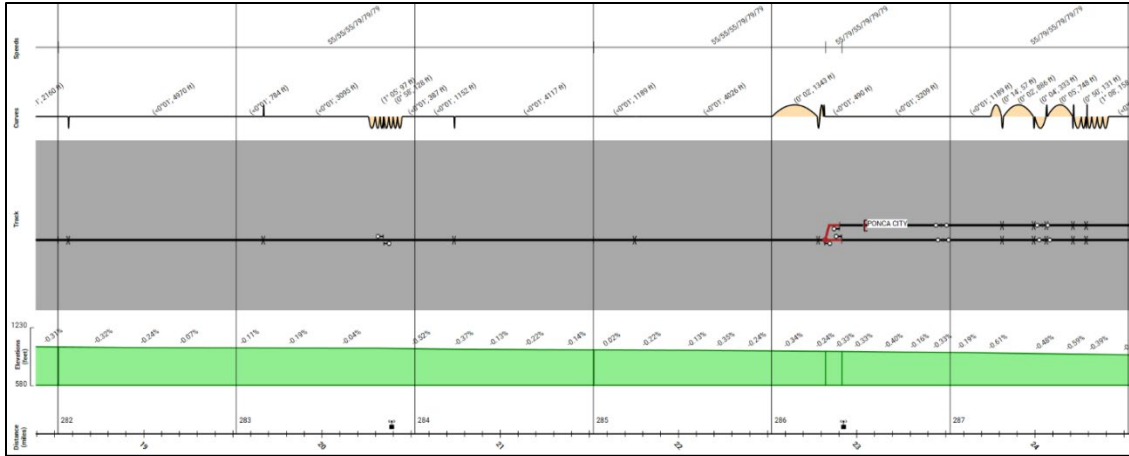

Figure C29. Red Rock Subdivision Mile 18.3–24.5

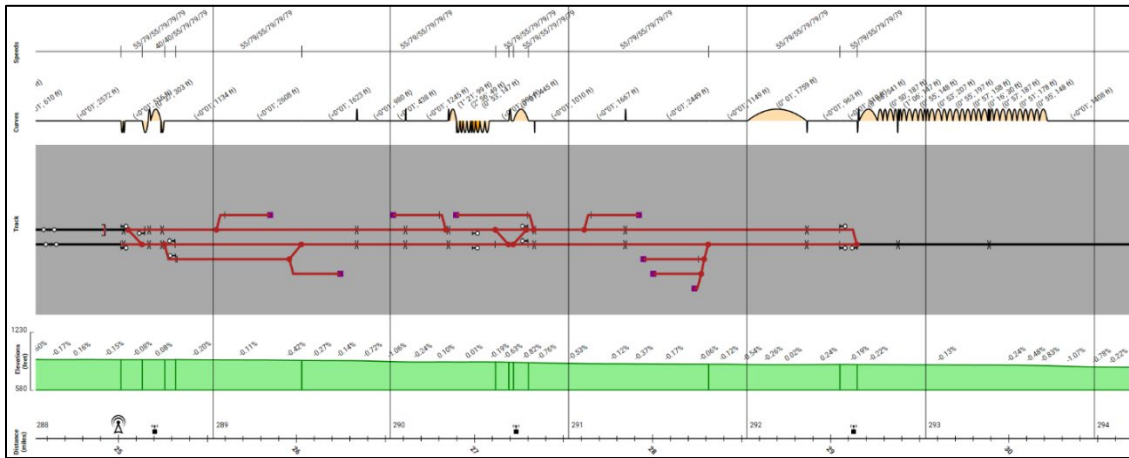

Figure C30. Red Rock Subdivision Mile 24.5–30.6

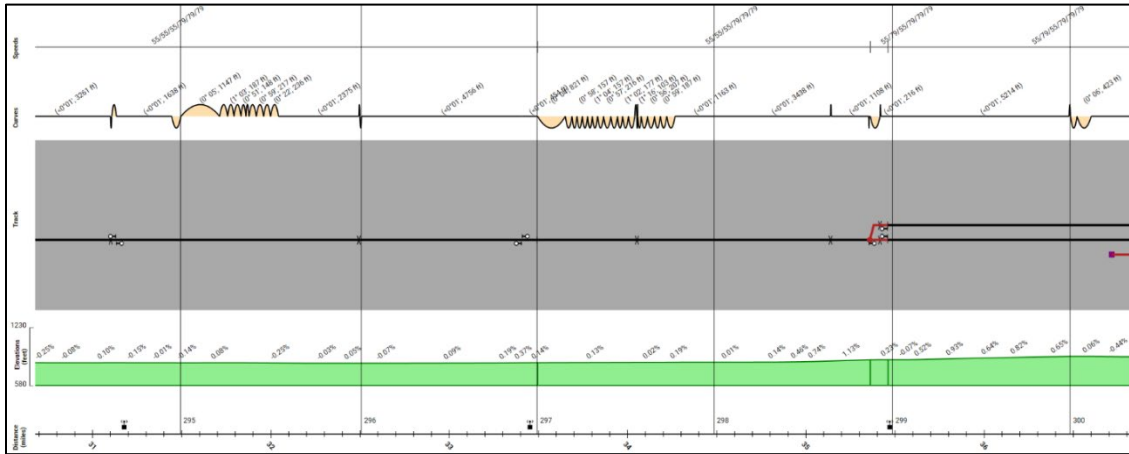

Figure C31. Red Rock Subdivision Mile 30.6–36.8

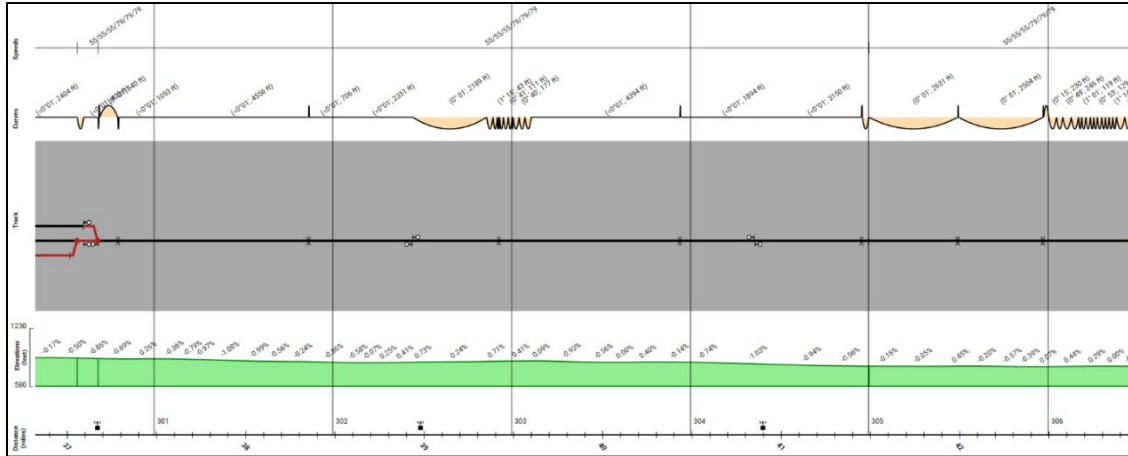

Figure C32. Red Rock Subdivision Mile 36.8–42.9

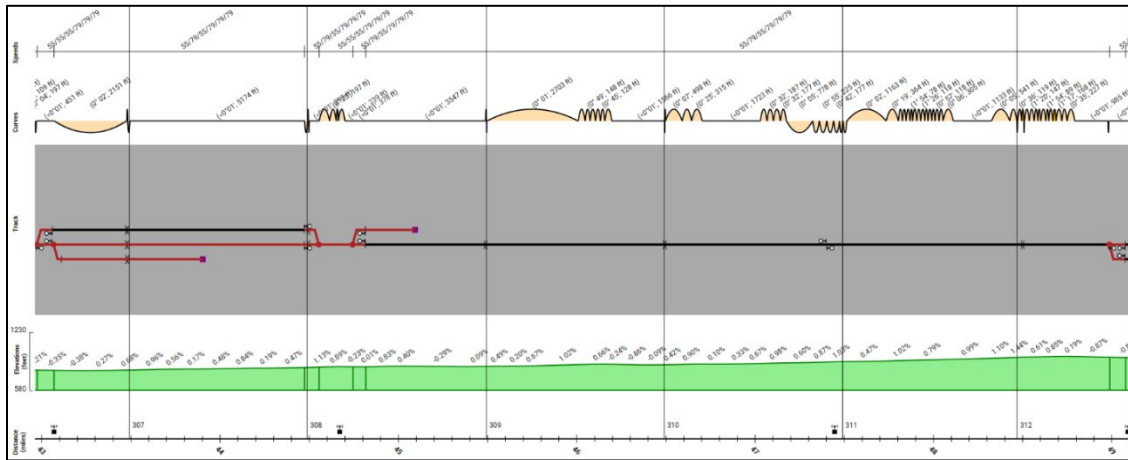

Figure C33. Red Rock Subdivision Mile 42.9–49.1

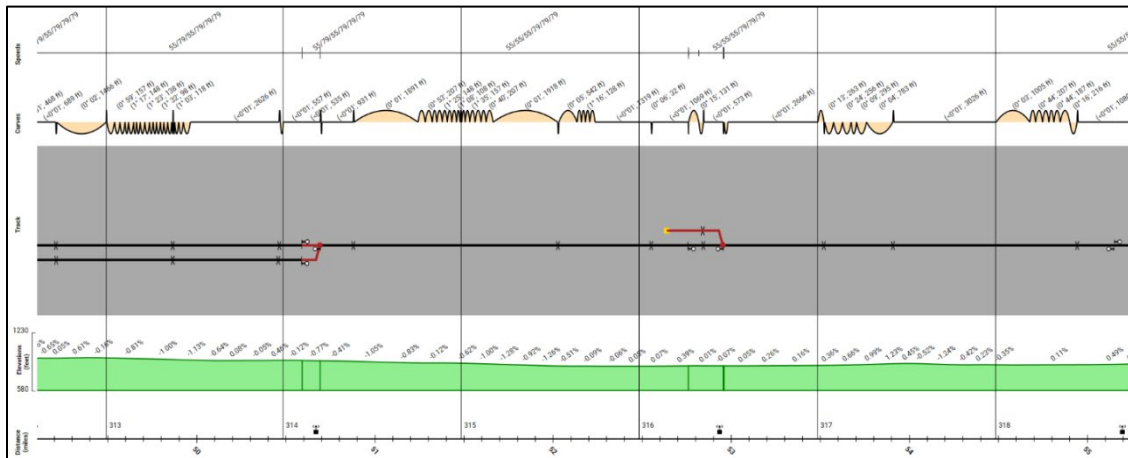

Figure C34. Red Rock Subdivision Mile 49.1–55.2

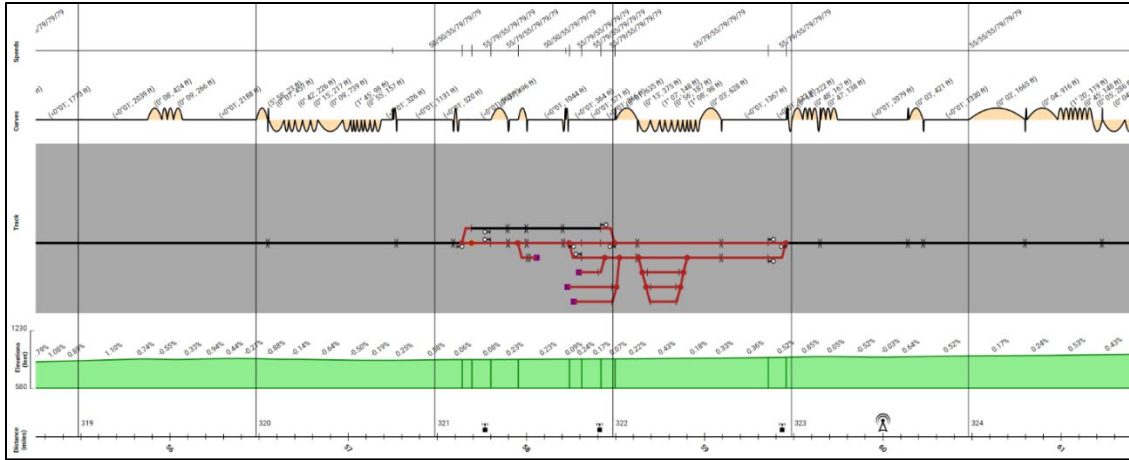

Figure C35. Red Rock Subdivision Mile 55.2–61.3

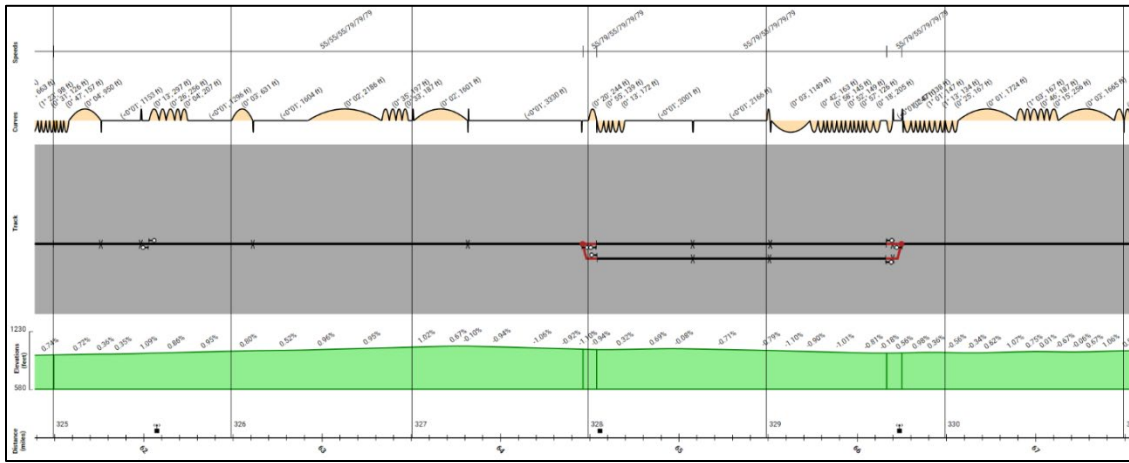

Figure C36. Red Rock Subdivision Mile 61.3–67.5

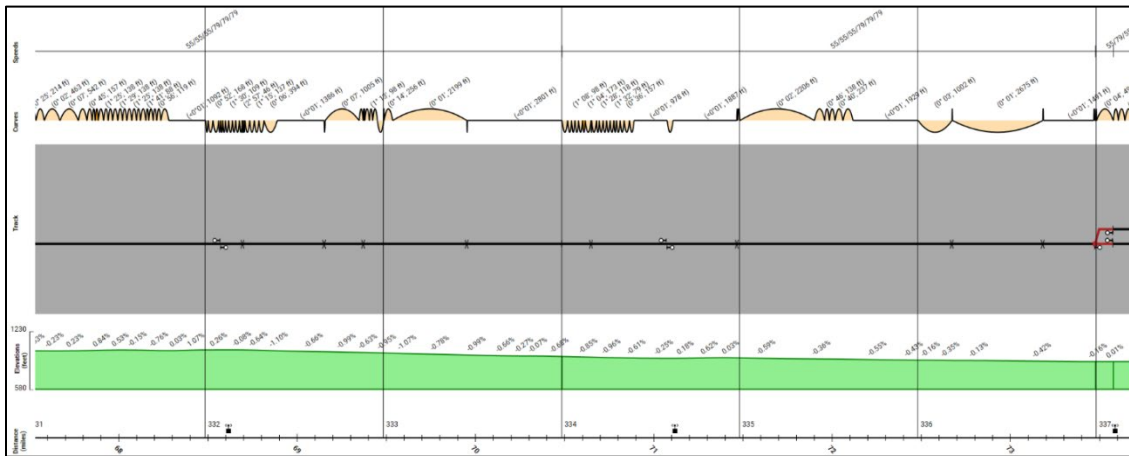

Figure C37. Red Rock Subdivision Mile 67.5–73.6

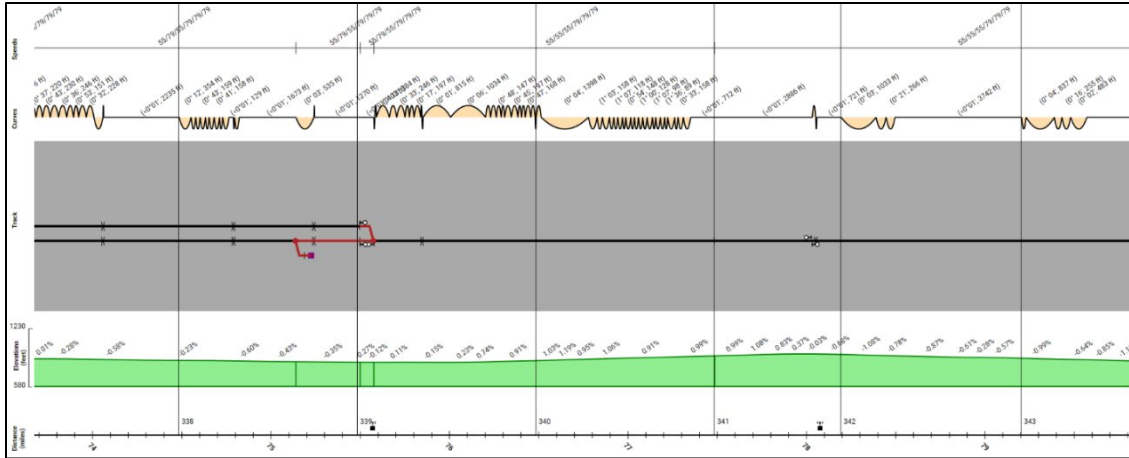

Figure C38. Red Rock Subdivision Mile 73.6–79.8

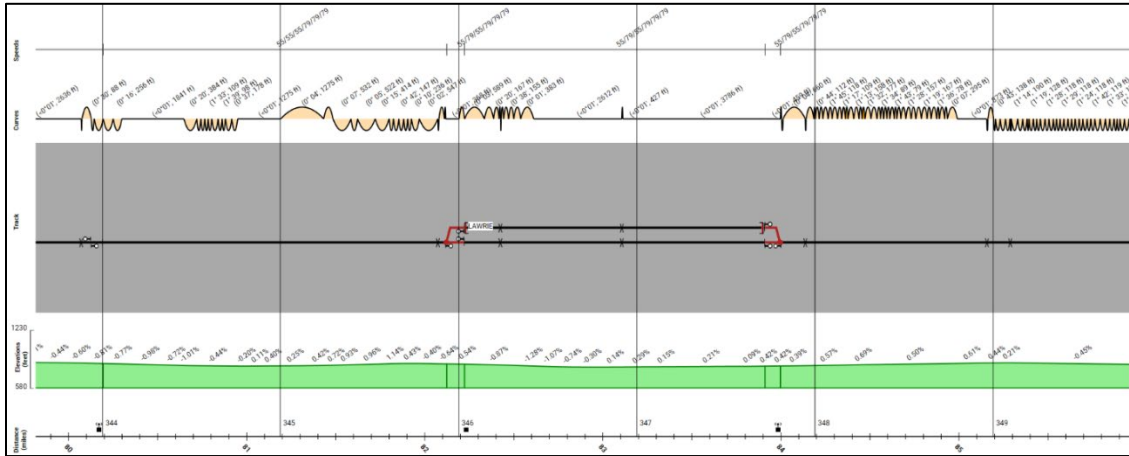

Figure C39. Red Rock Subdivision Mile 79.8–85.9

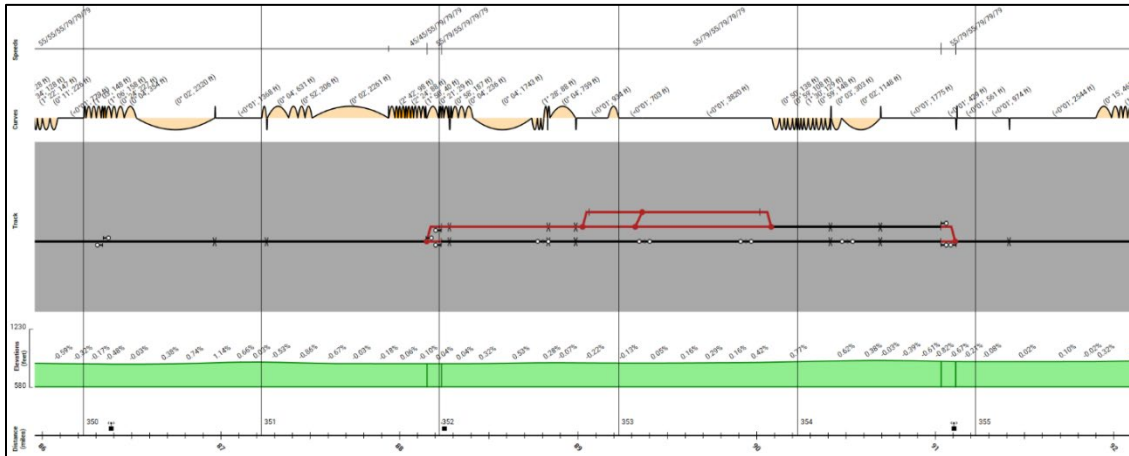

Figure C40. Red Rock Subdivision Mile 85.9–92.0

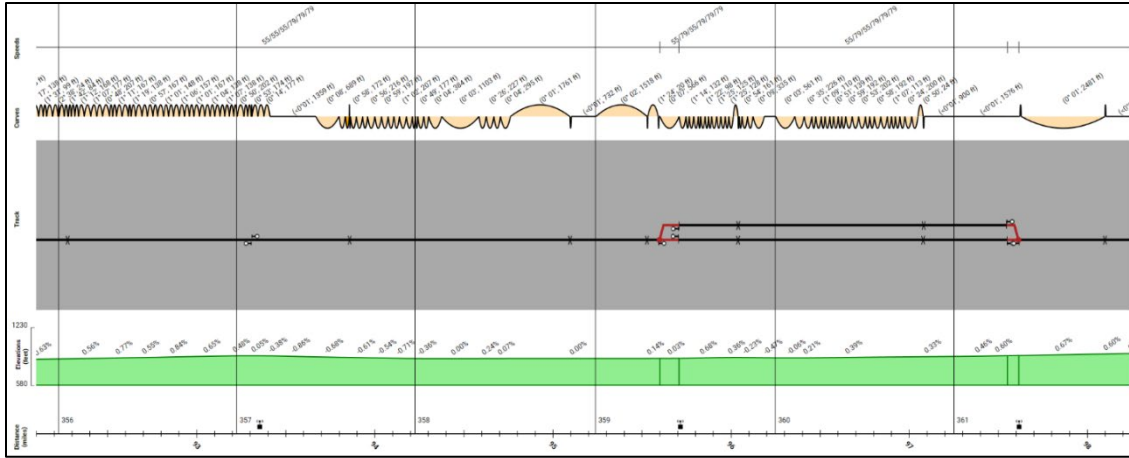

Figure C41. Red Rock Subdivision Mile 92.0-98.2

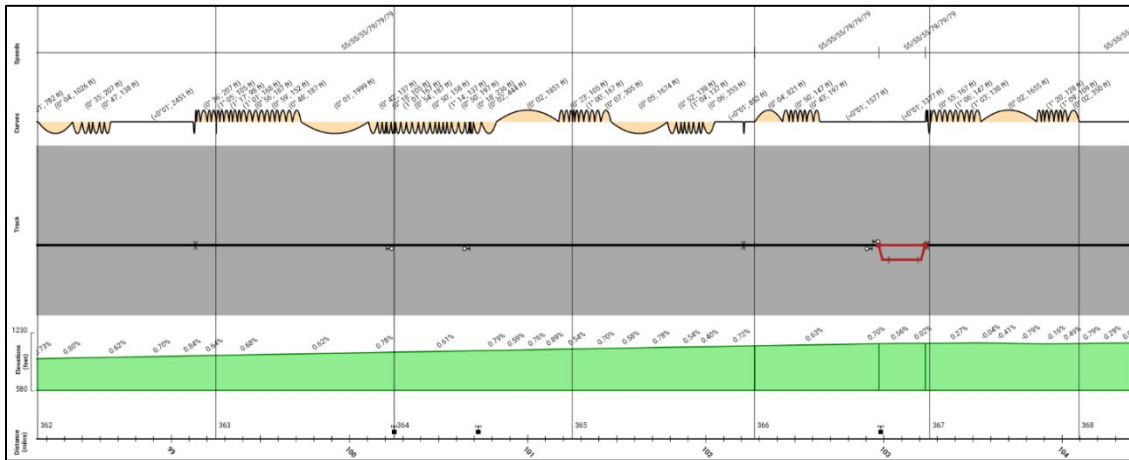

Figure C42. Red Rock Subdivision Mile 98.2-104.3

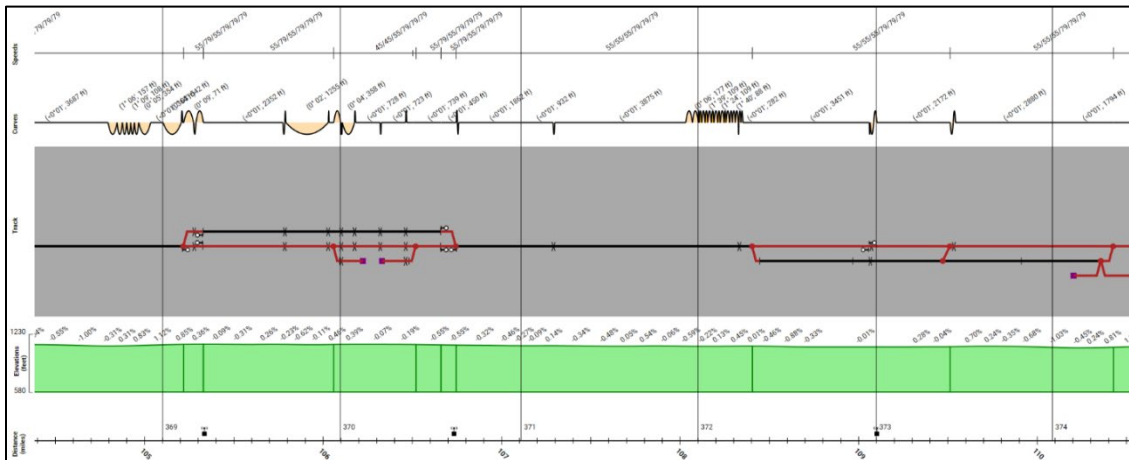

Figure C43. Red Rock Subdivision Mile 104.3-110.5

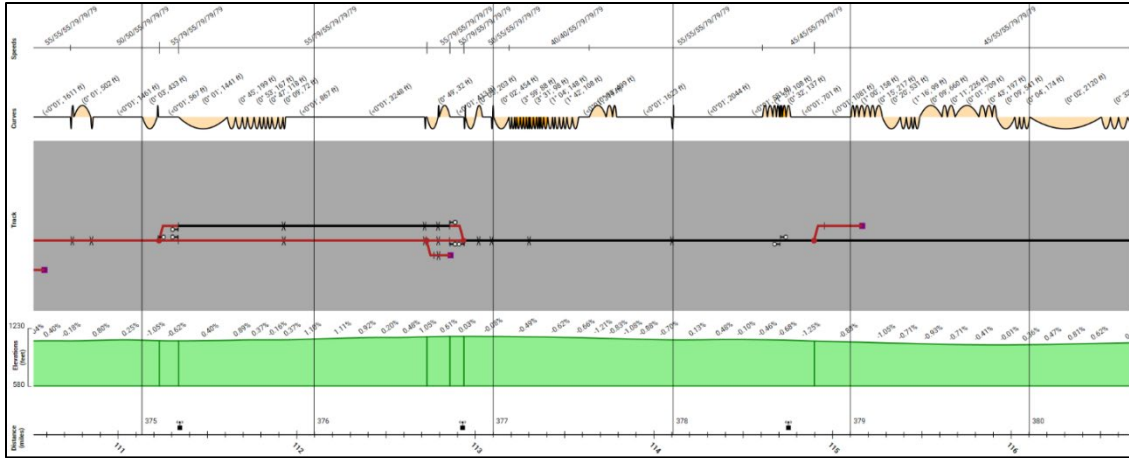

Figure C44. Red Rock Subdivision Mile 110.5–116.6

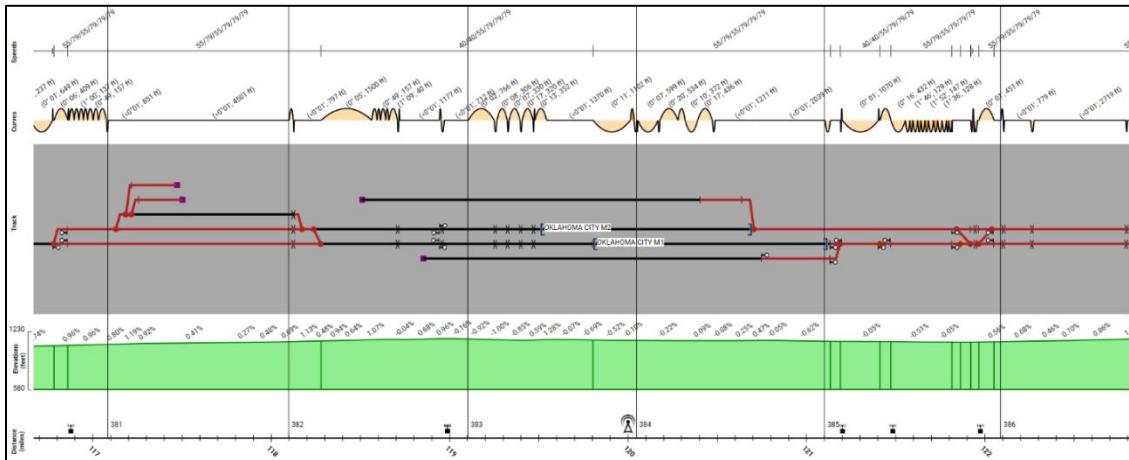

Figure C45. Red Rock Subdivision Mile 116.6–122.8

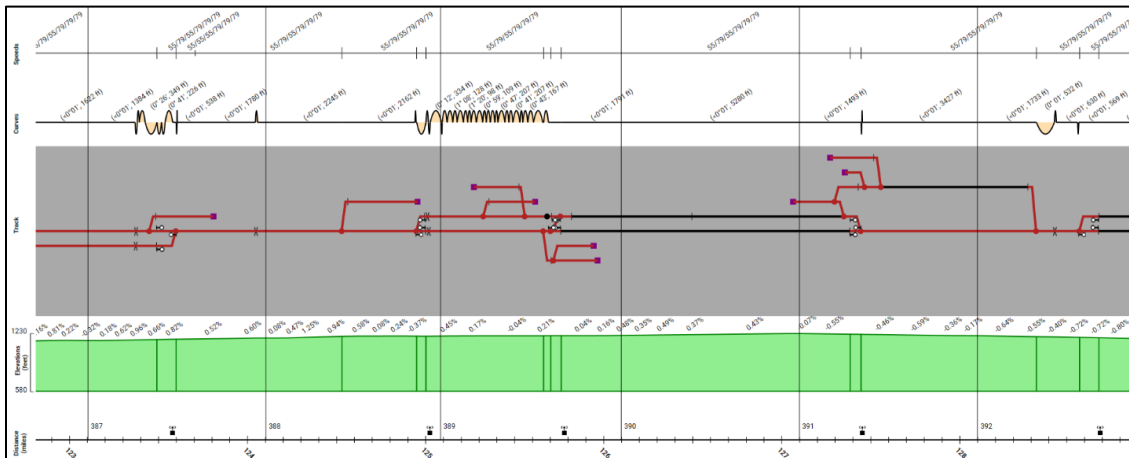

Figure C46. Red Rock Subdivision Mile 122.8–128.9

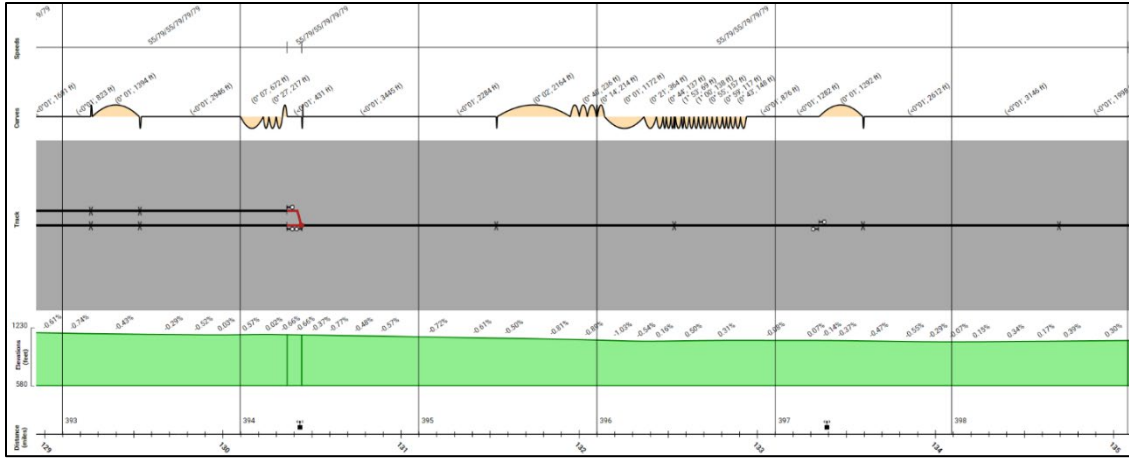

Figure C47. Red Rock Subdivision Mile 128.9–135.0

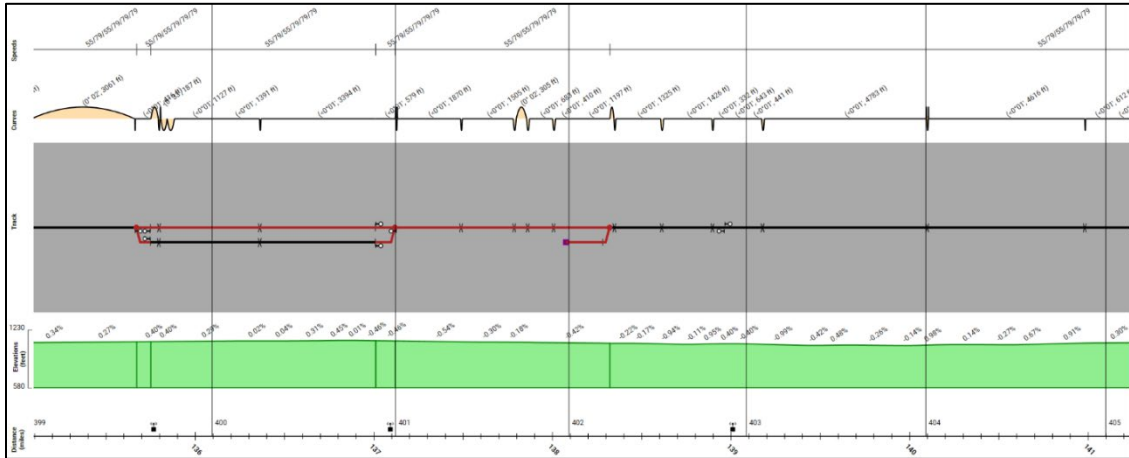

Figure C48. Red Rock Subdivision Mile 135.0–141.2

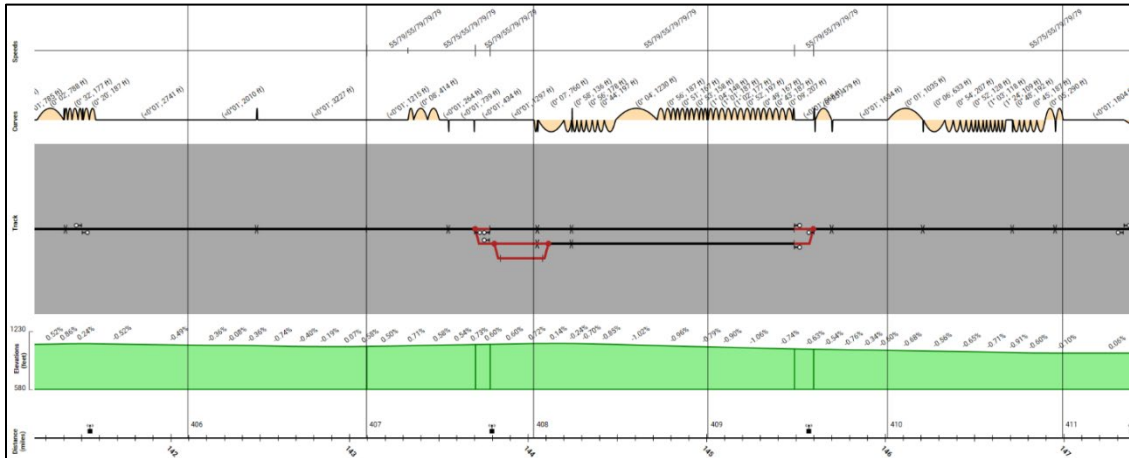

Figure C49. Red Rock Subdivision Mile 141.2–147.3

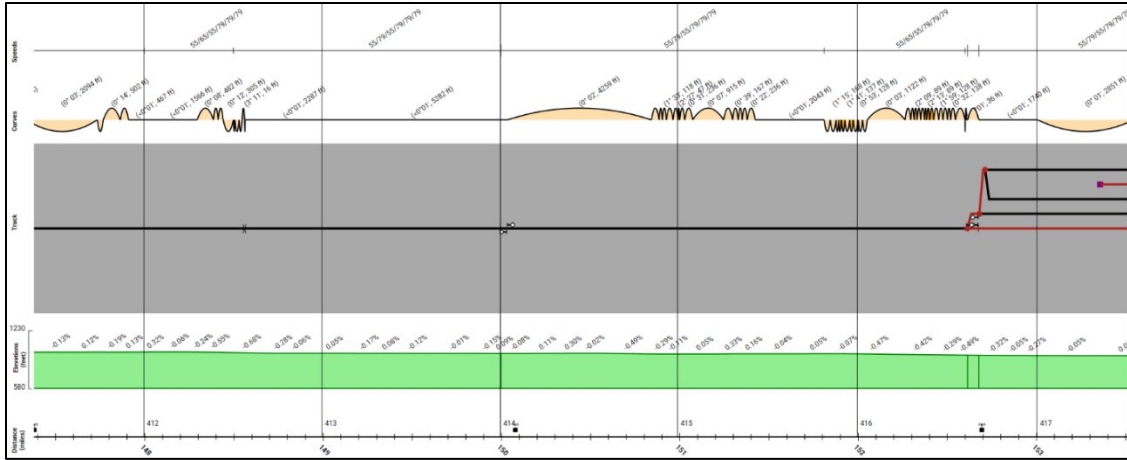

Figure C50. Red Rock Subdivision Mile 147.3–153.5

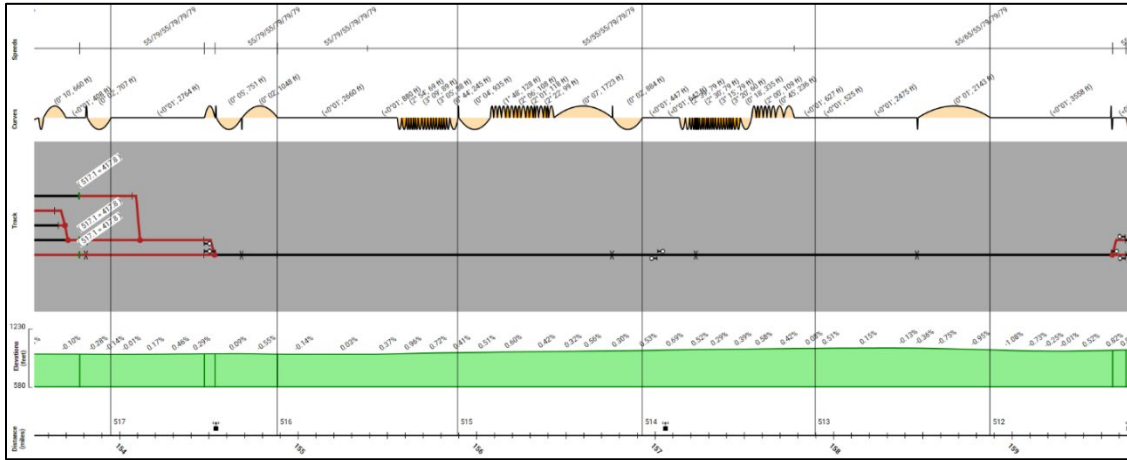

Figure C51. Red Rock Subdivision Mile 153.5–159.6

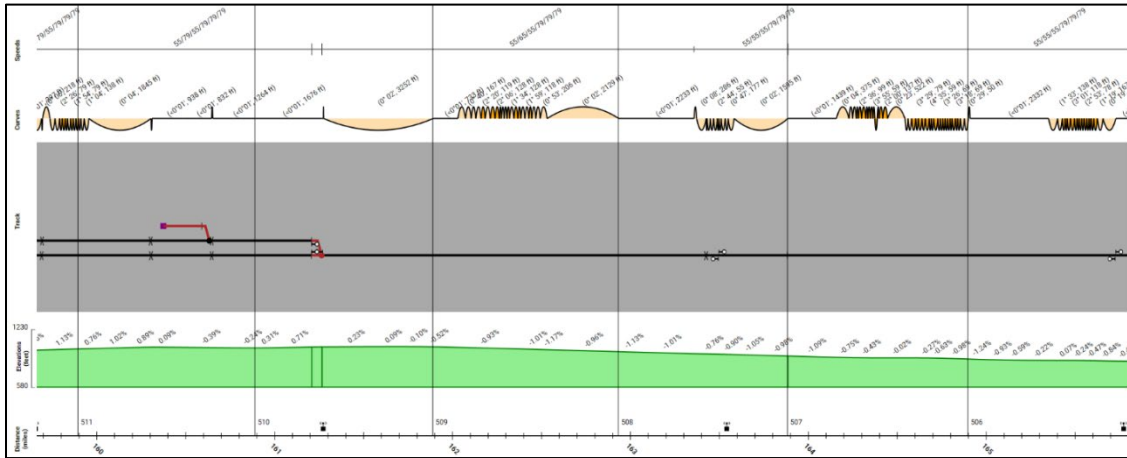

Figure C52. Red Rock Subdivision Mile 159.6–165.7

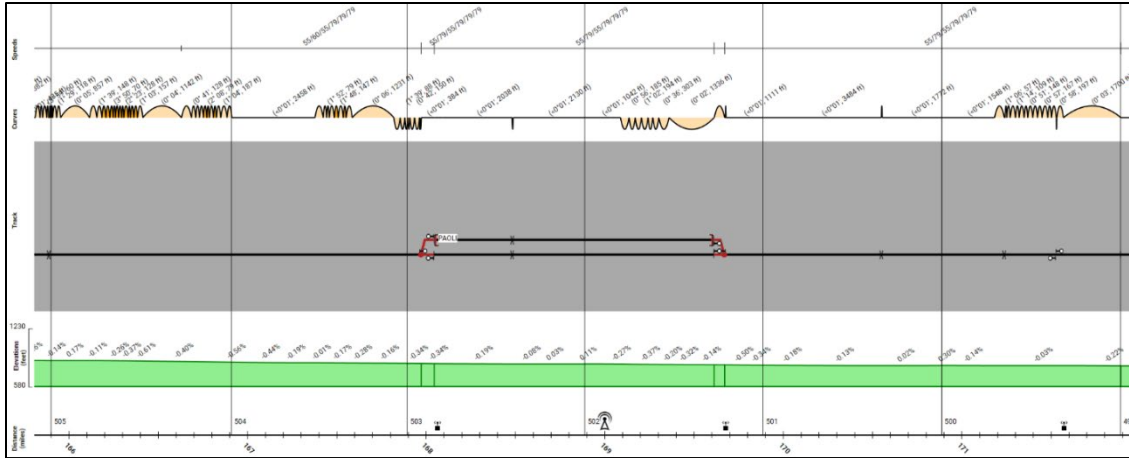

Figure C53. Red Rock Subdivision Mile 165.7–171.9

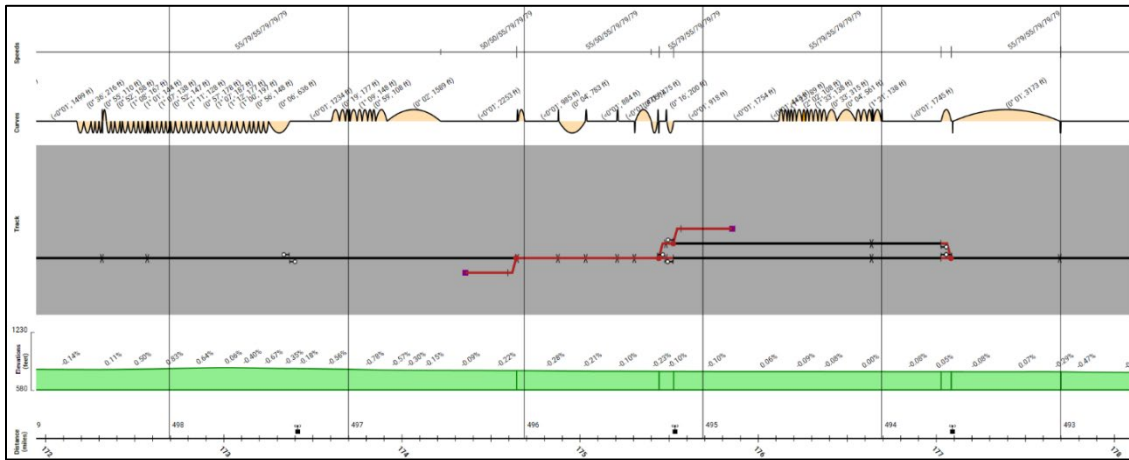

Figure C54. Red Rock Subdivision Mile 171.9–178.0

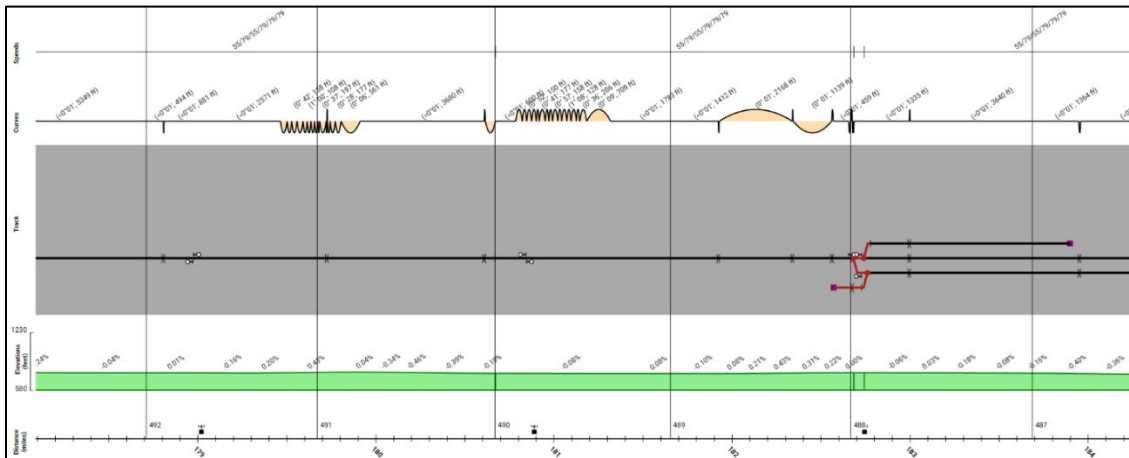

Figure C55. Red Rock Subdivision Mile 178.0–184.2

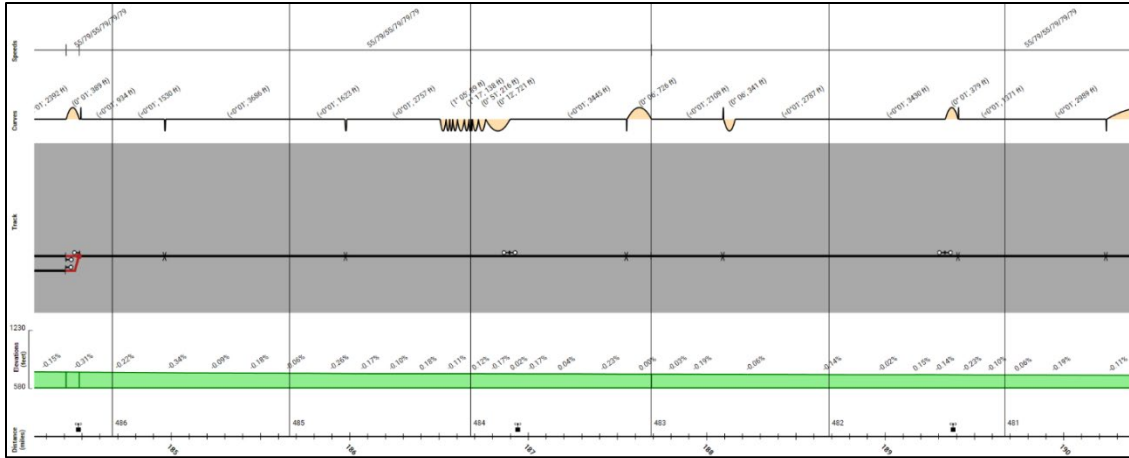

Figure C56. Red Rock Subdivision Mile 184.2–190.3

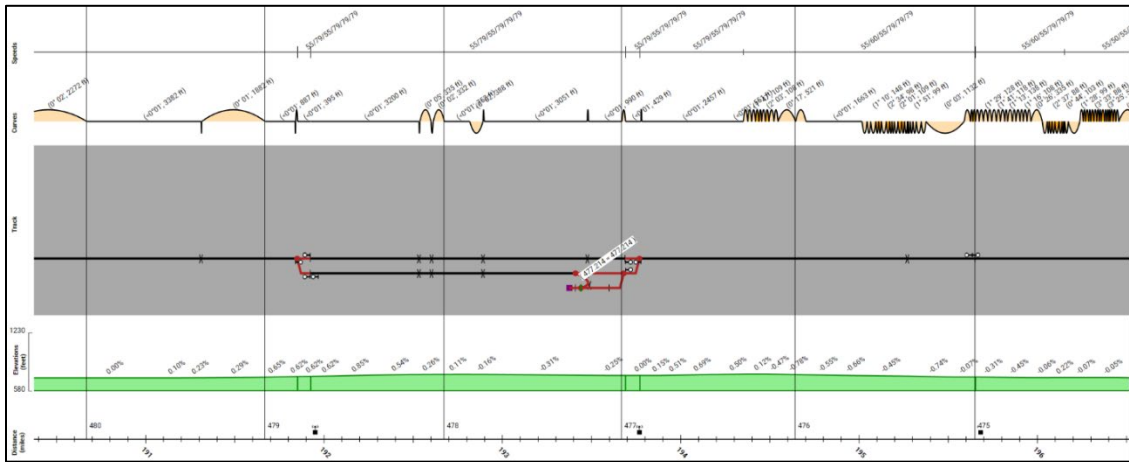

Figure C57. Red Rock Subdivision Mile 190.3–196.5

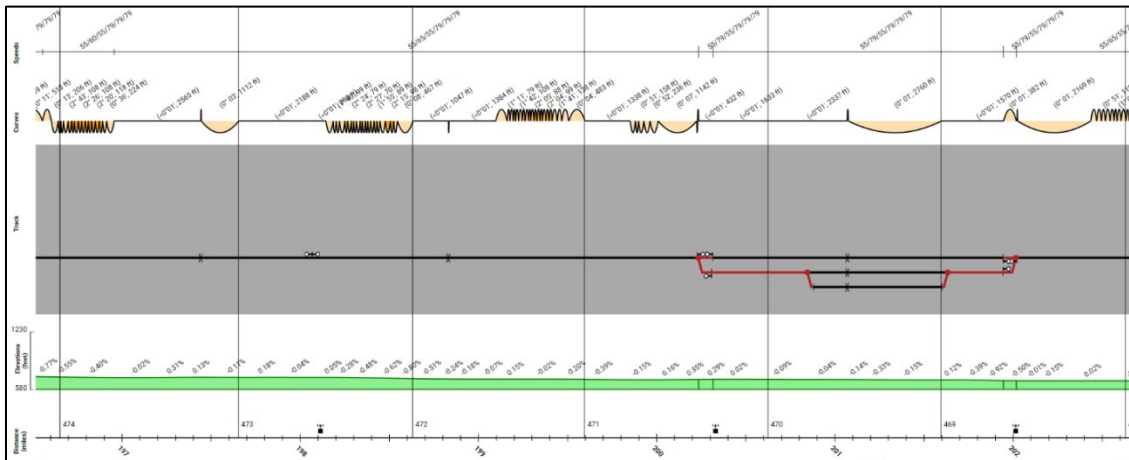

Figure C58. Red Rock Subdivision Mile 196.5–202.6

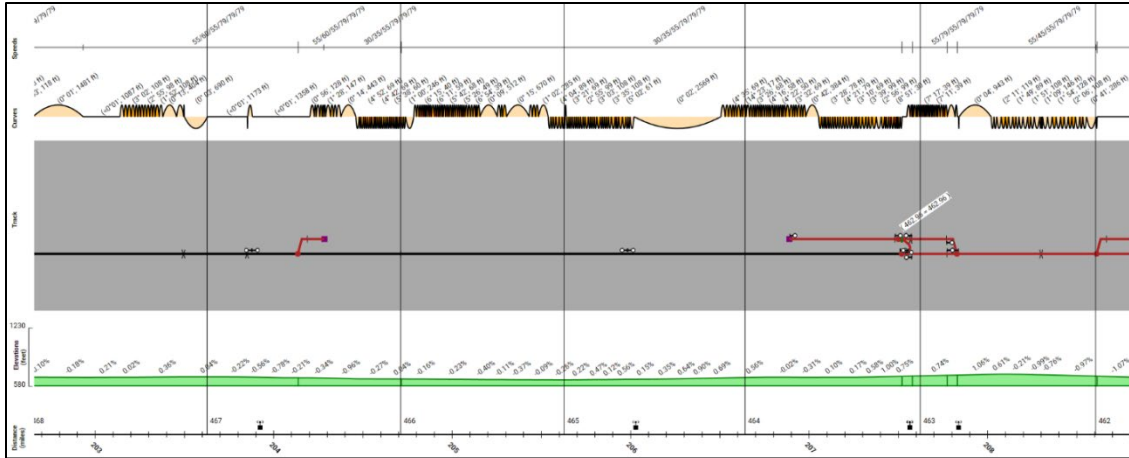

Figure C59. Red Rock Subdivision Mile 202.6–208.7

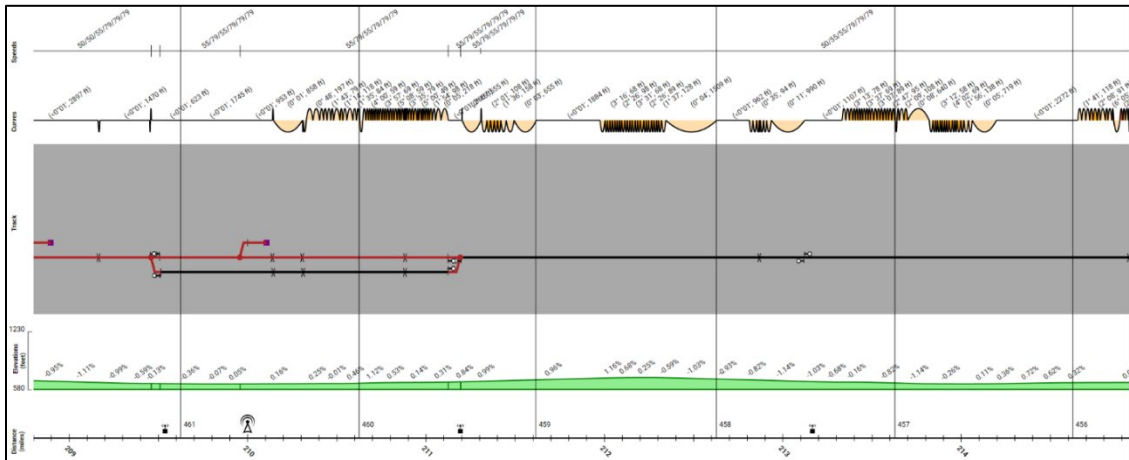

Figure C60. Red Rock Subdivision Mile 208.7–214.9

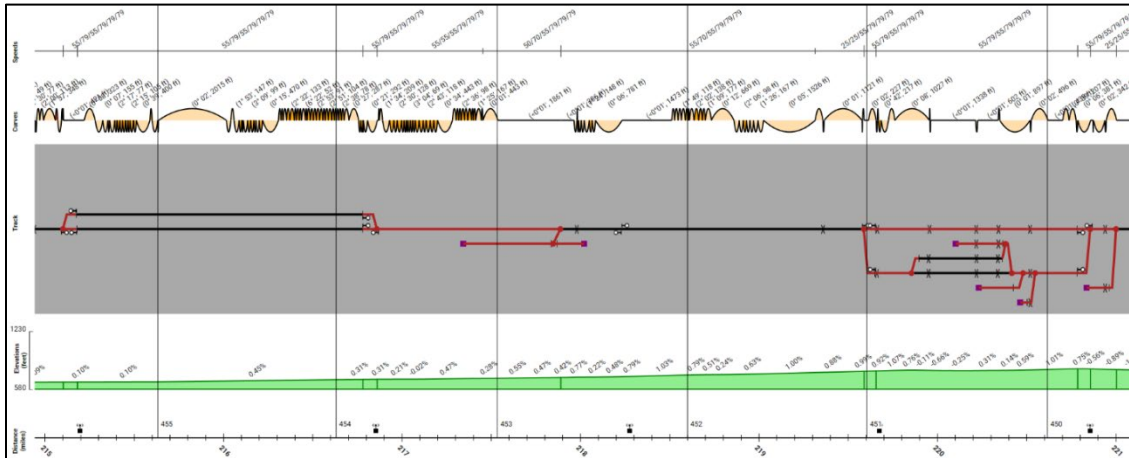

Figure C61. Red Rock Subdivision Mile 214.9–221.0

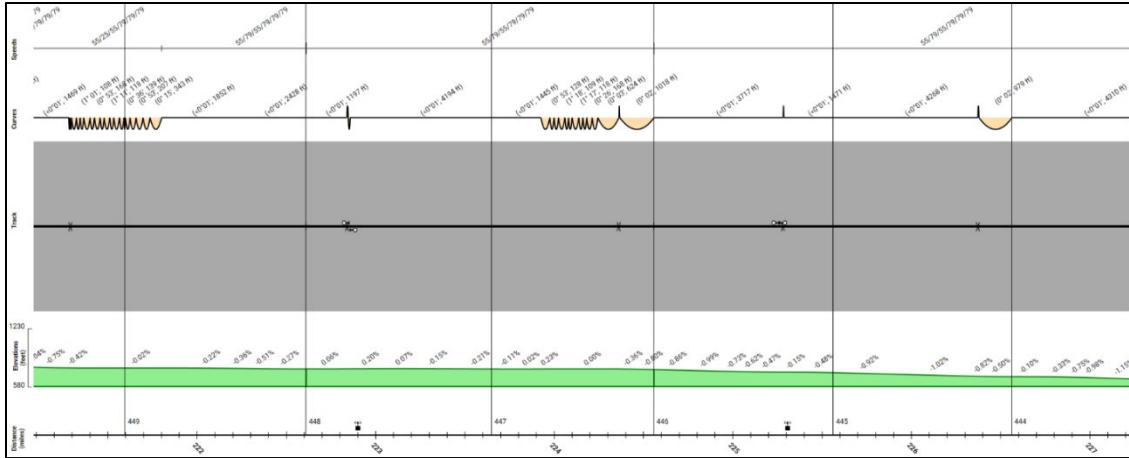

Figure C62. Red Rock Subdivision Mile 221.0–227.2

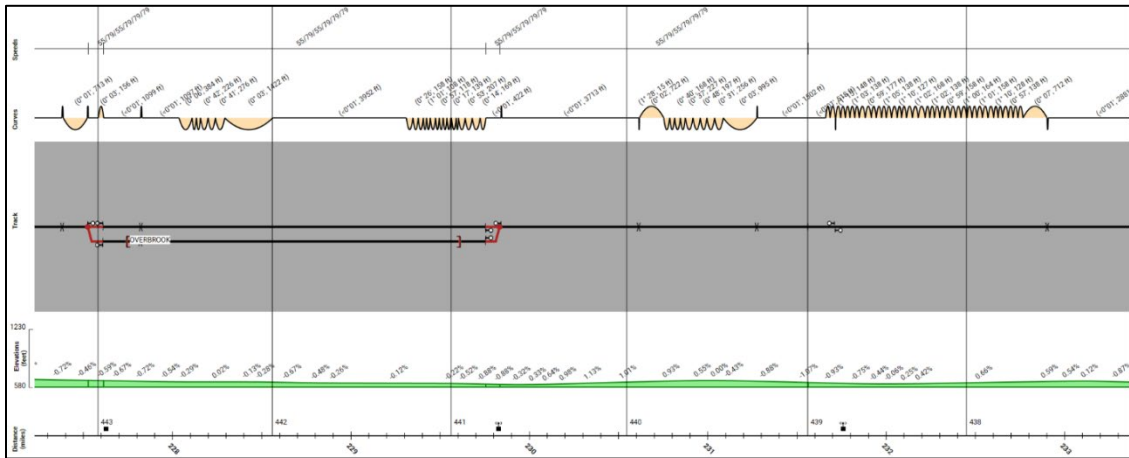

Figure C63. Red Rock Subdivision Mile 227.2–233.3

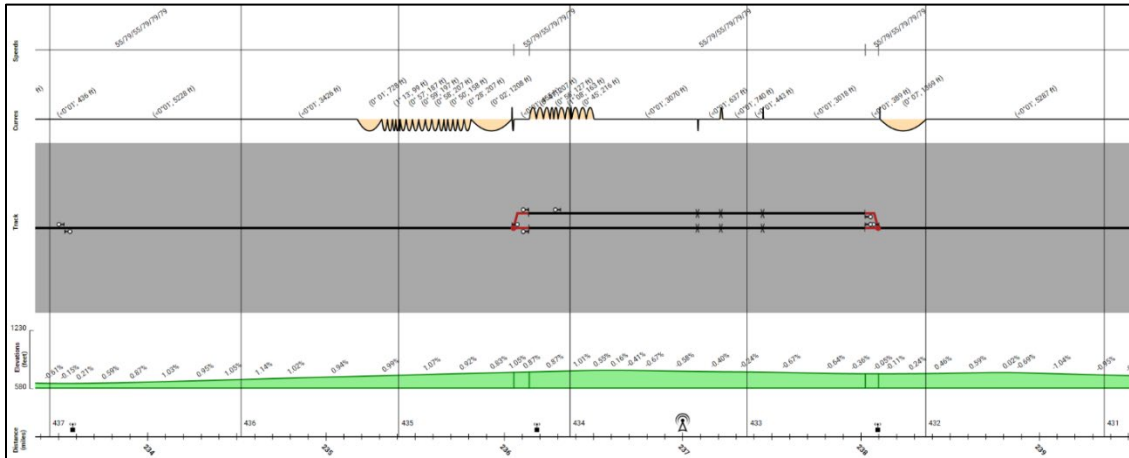

Figure C64. Red Rock Subdivision Mile 233.3–239.5

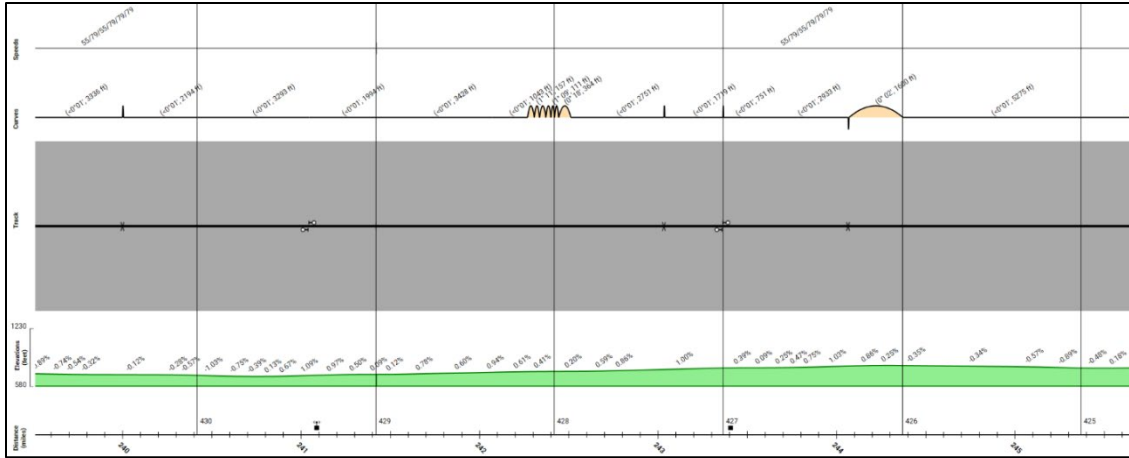

Figure C65. Red Rock Subdivision Mile 239.5–245.6

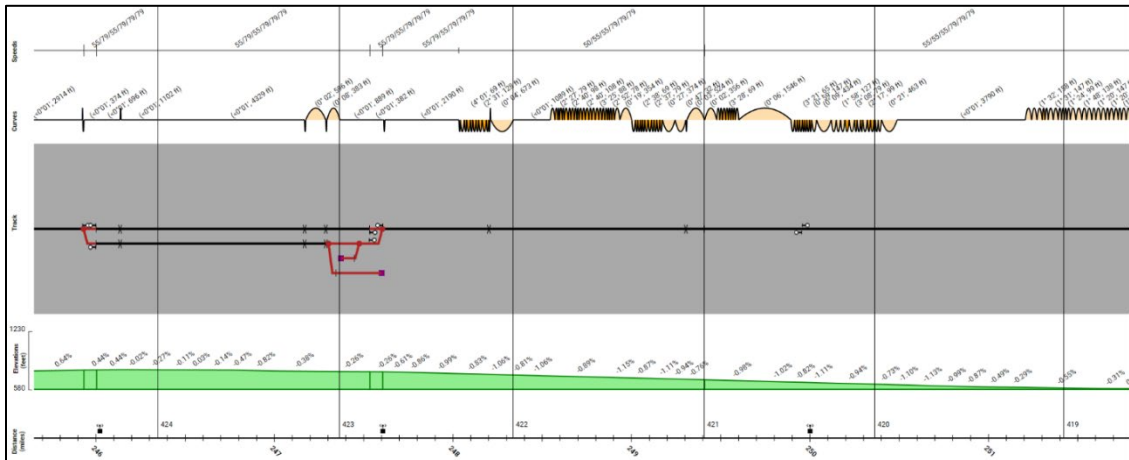

Figure C66. Red Rock Subdivision Mile 245.6–251.7

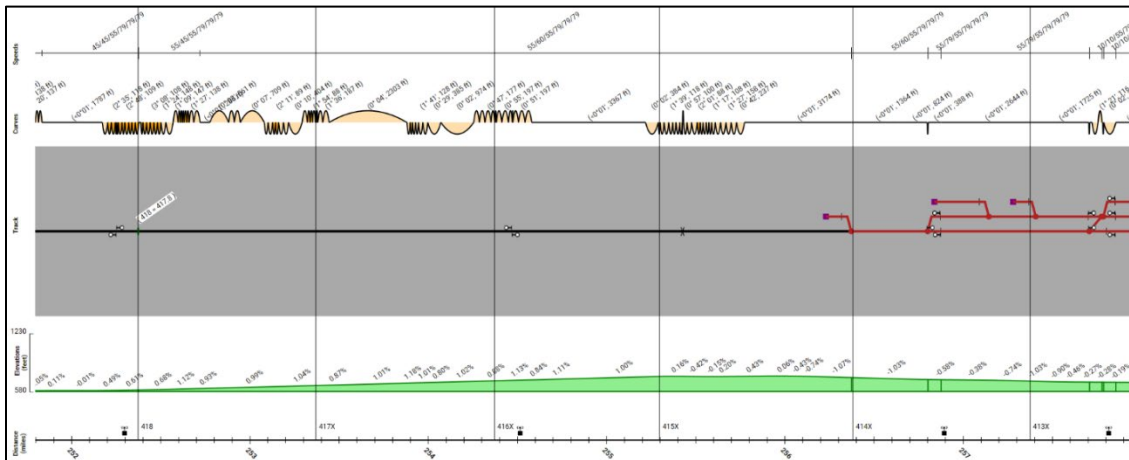

Figure C67. Red Rock Subdivision Mile 251.7–257.9

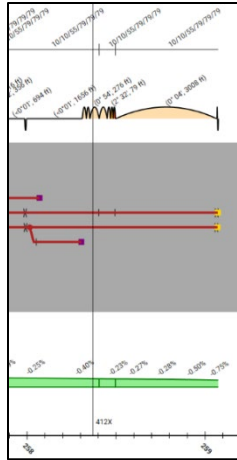

Figure C68. Red Rock Subdivision Mile 257.9–259.1

Appendix D. Node Network Diagram (Traffic Control Blocks)

This appendix contains the node network diagrams for the analysis territory.

The node network is a virtual construct of traffic control blocks generated automatically from the rail system infrastructure data. The node network is used by the GTMS Central Dispatcher (CD) to determine train movement authorities. The CD uses the node network to determine possible paths through the system along a train's timetable route, and sets movement authorities to trains after ascertaining that moves are deadlock-preventing (i.e., will not result in trains being unable to advance due to opposing trains blocking all possible paths).

The node network diagrams are useful for analyzing simulated train movements and the dispatching process.

In Figure D1, the left side shows sample track from the track chart and, below it, a corresponding section of a node network diagram. On the right is a legend describing the information contained in the node network diagram.

The charts are for the three territory subdivisions (Ft. Worth North, Wichita Falls and Red Rock).

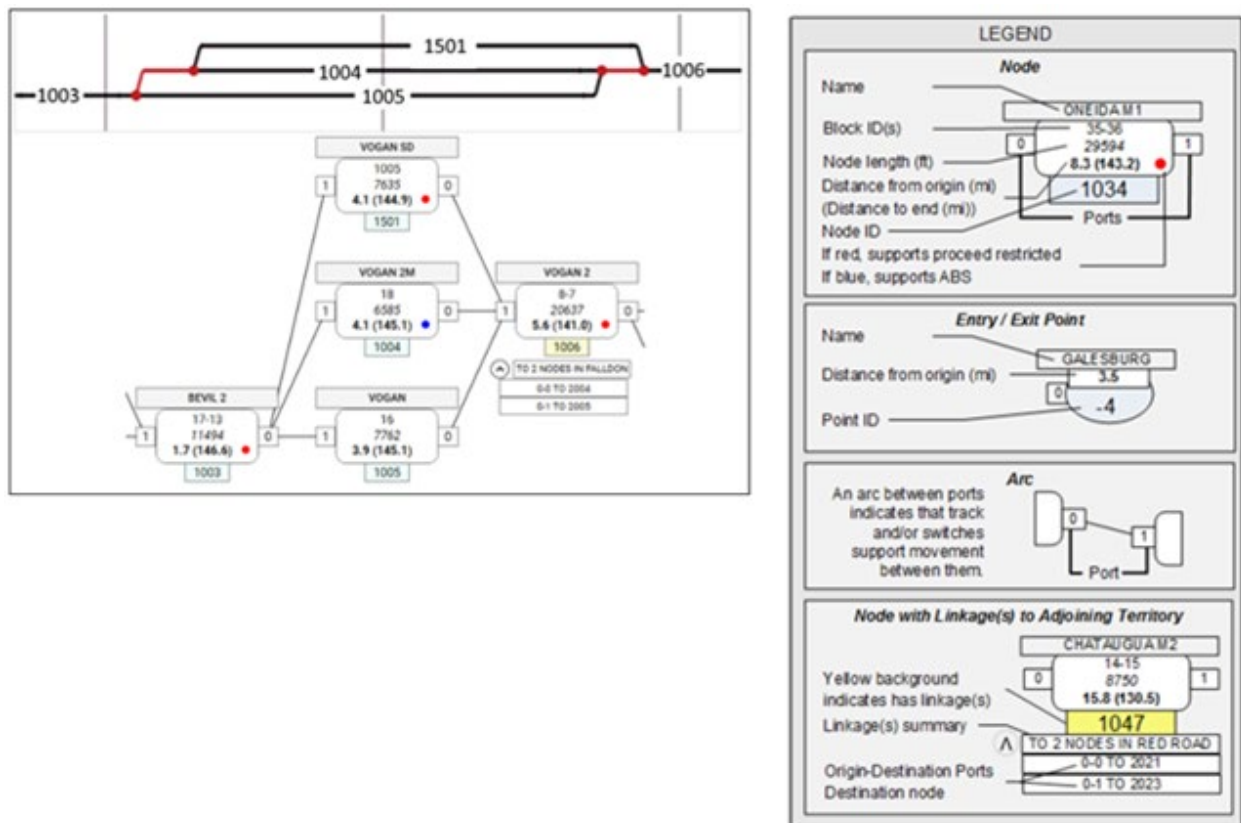

Figure D1. Track Chart and Corresponding Node Network

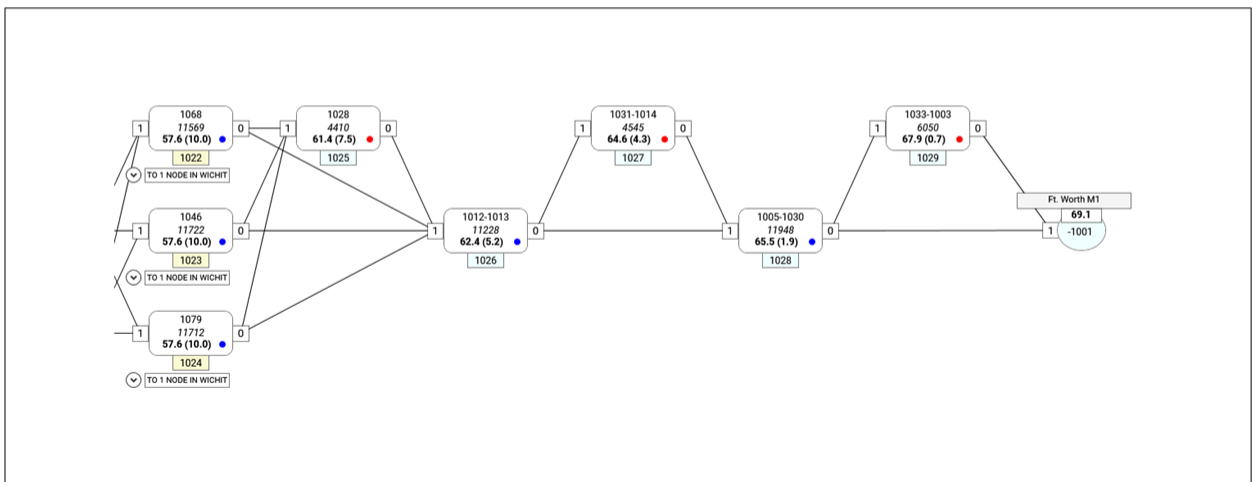
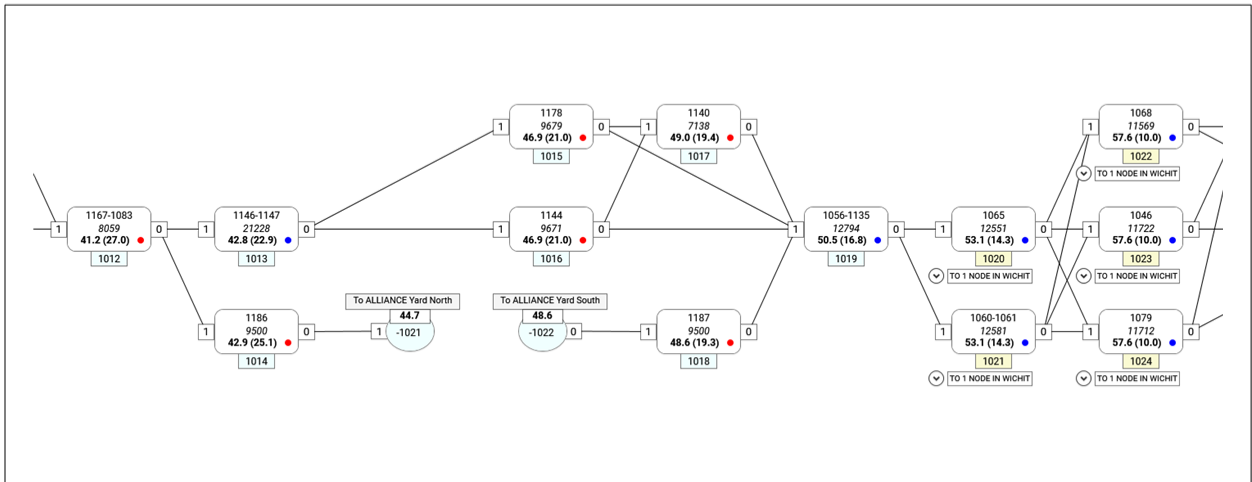
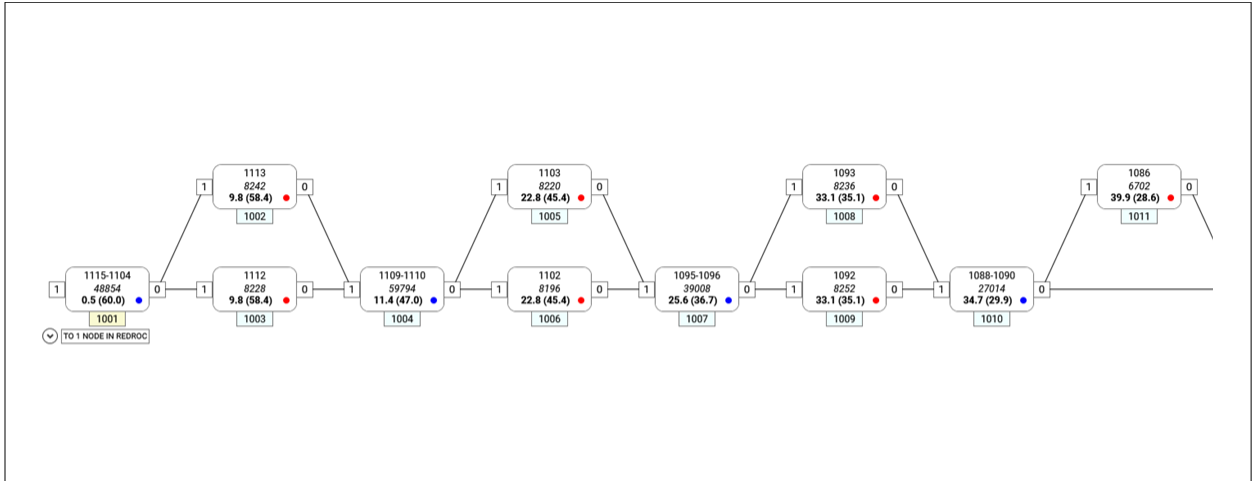

Figure D2. Ft. Worth Subdivision

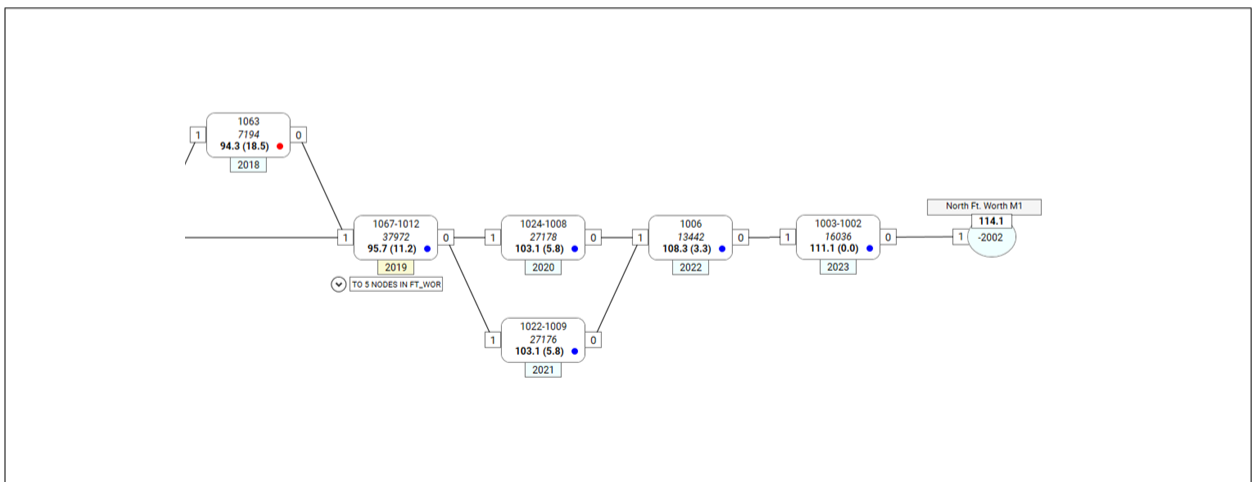
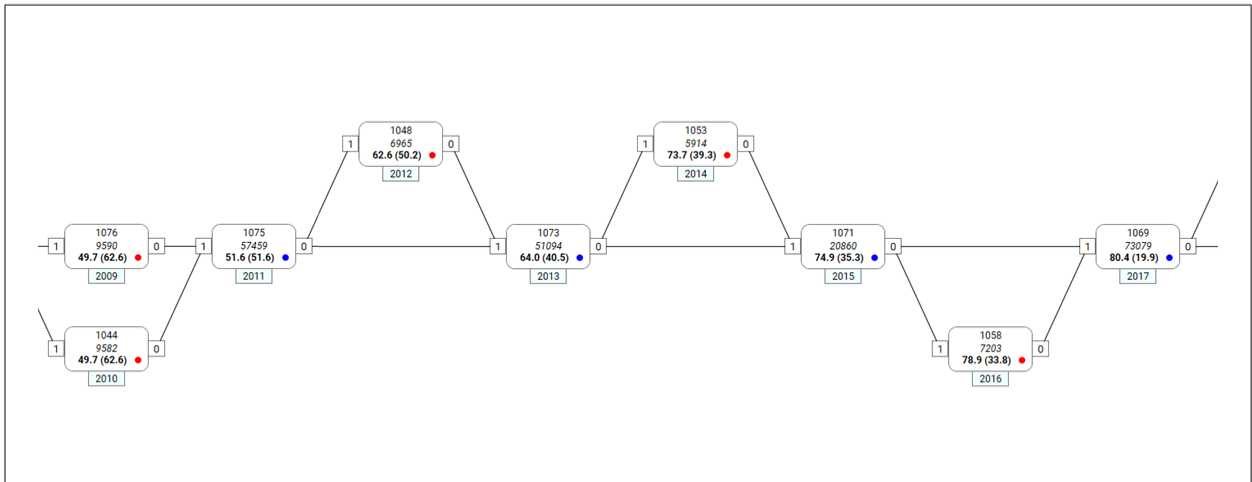
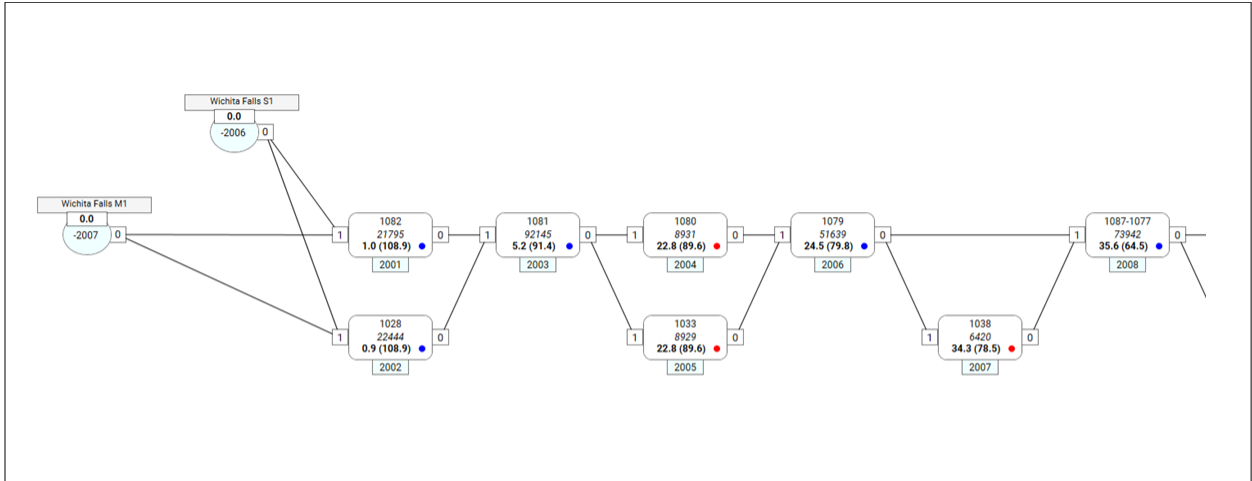

Figure D3. Wichita Falls Subdivision

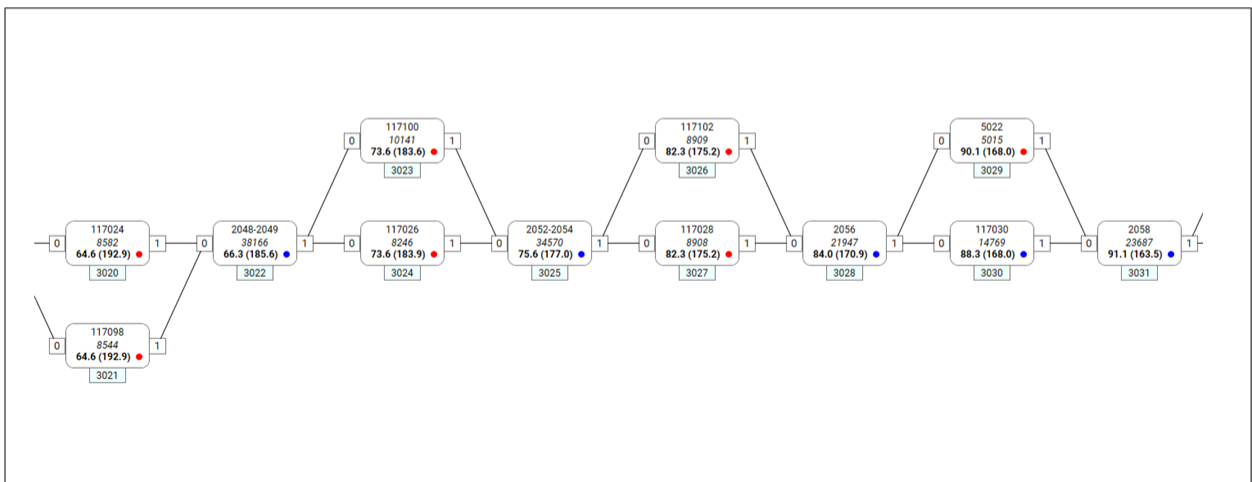
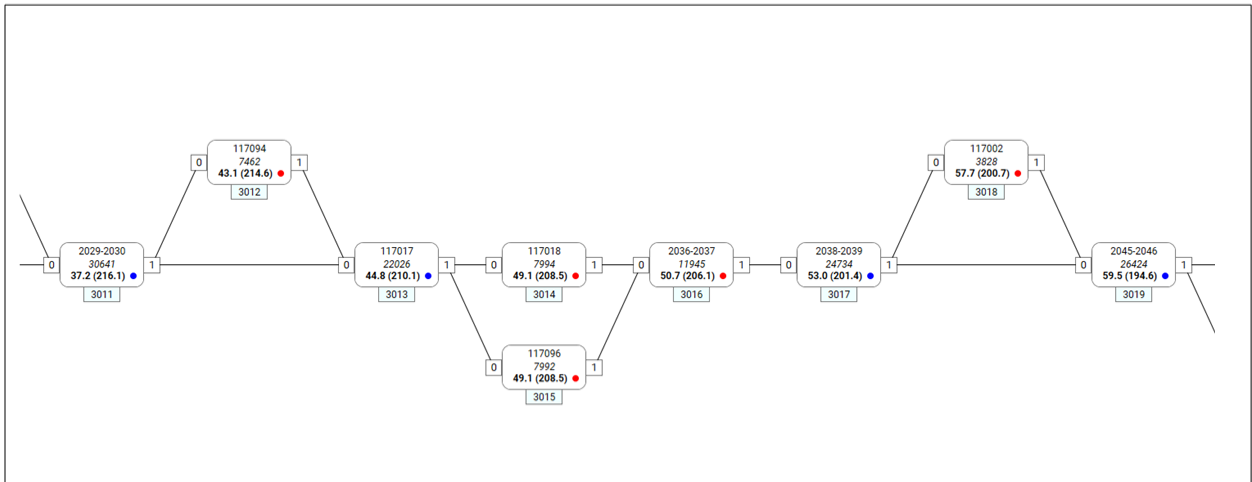
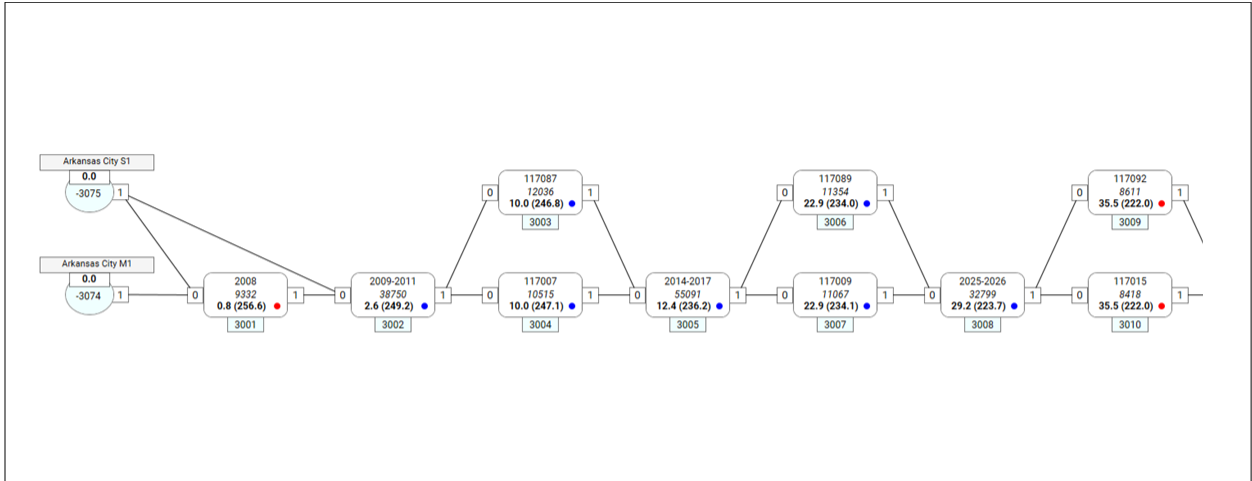
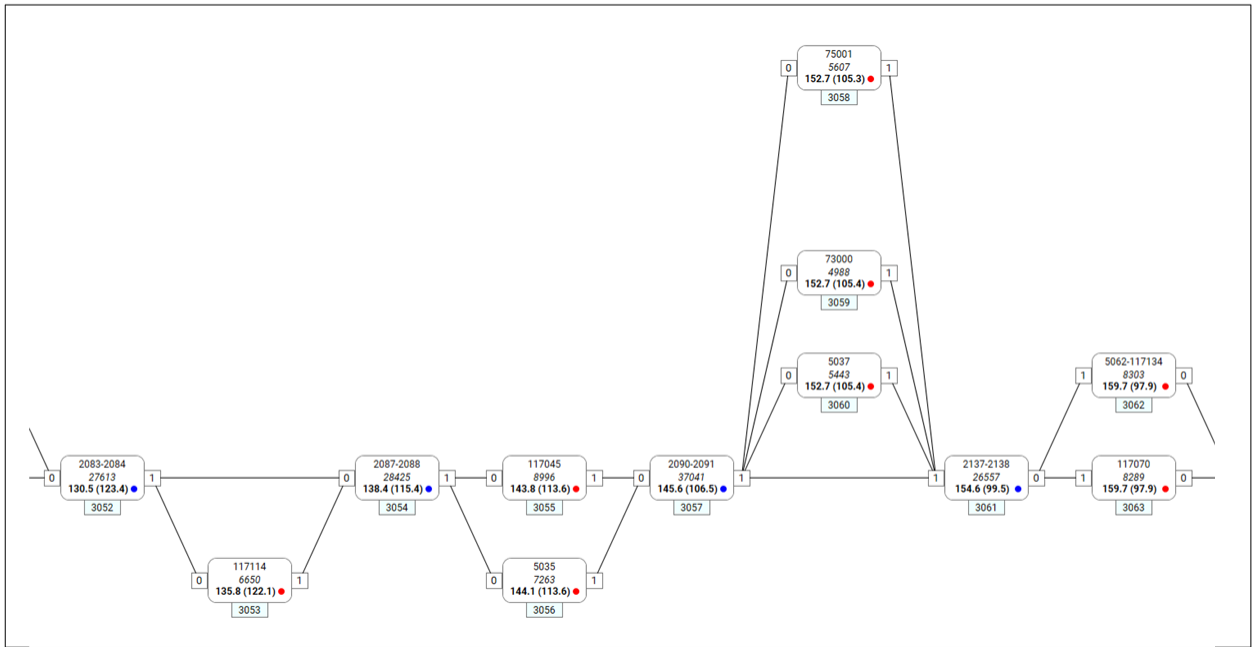
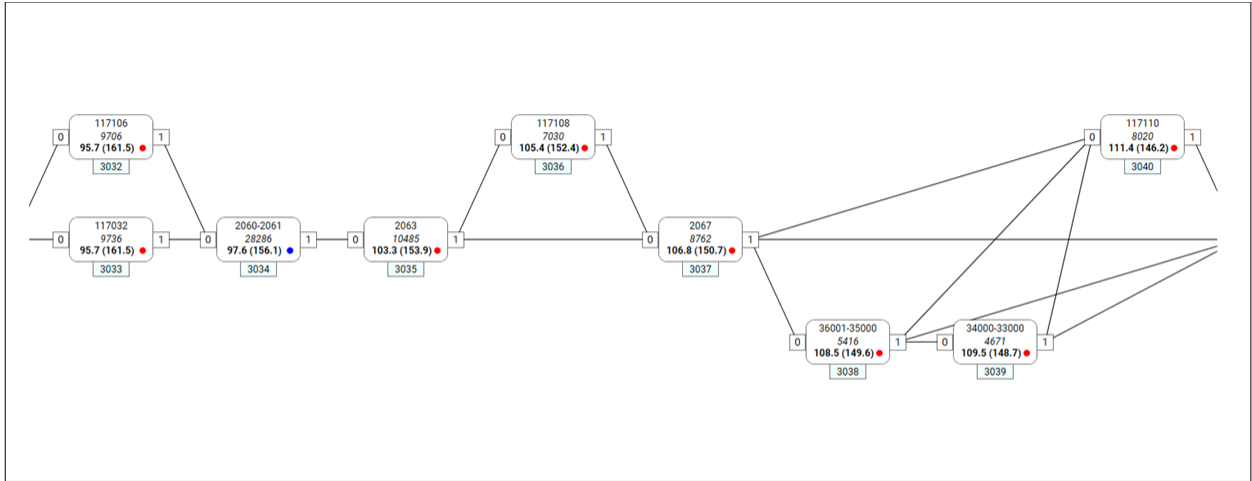
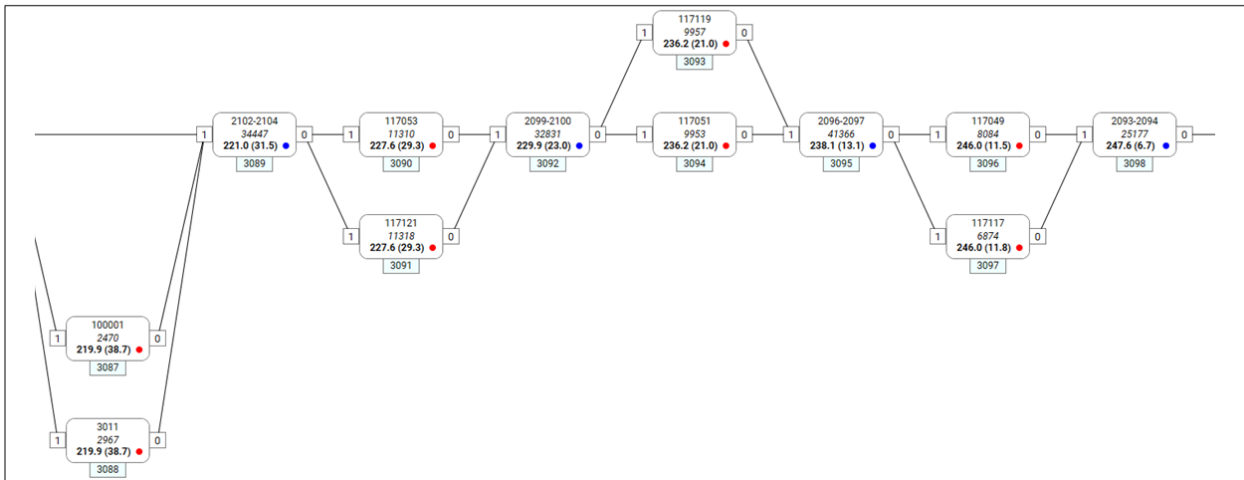
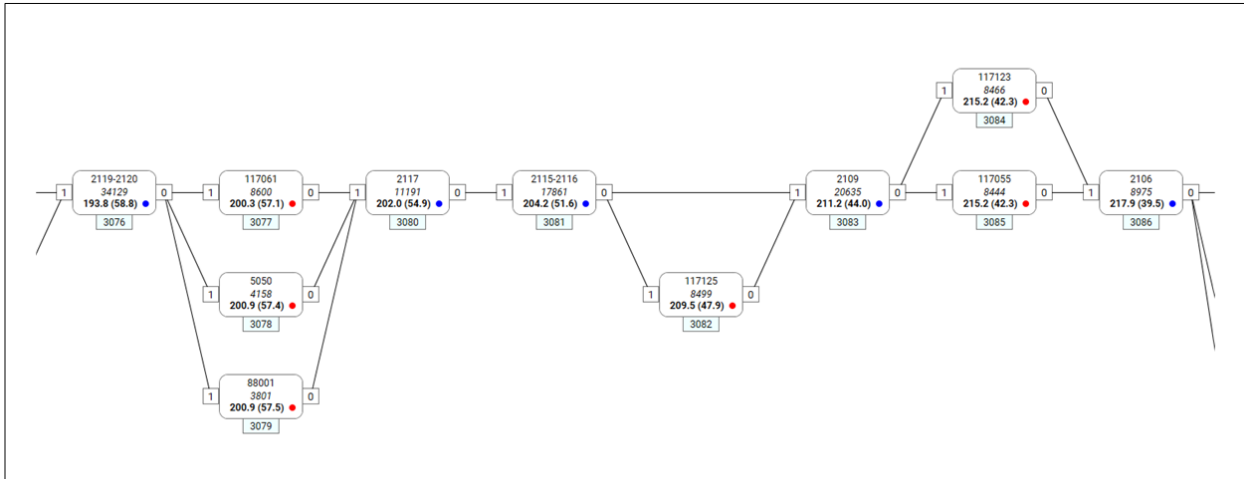
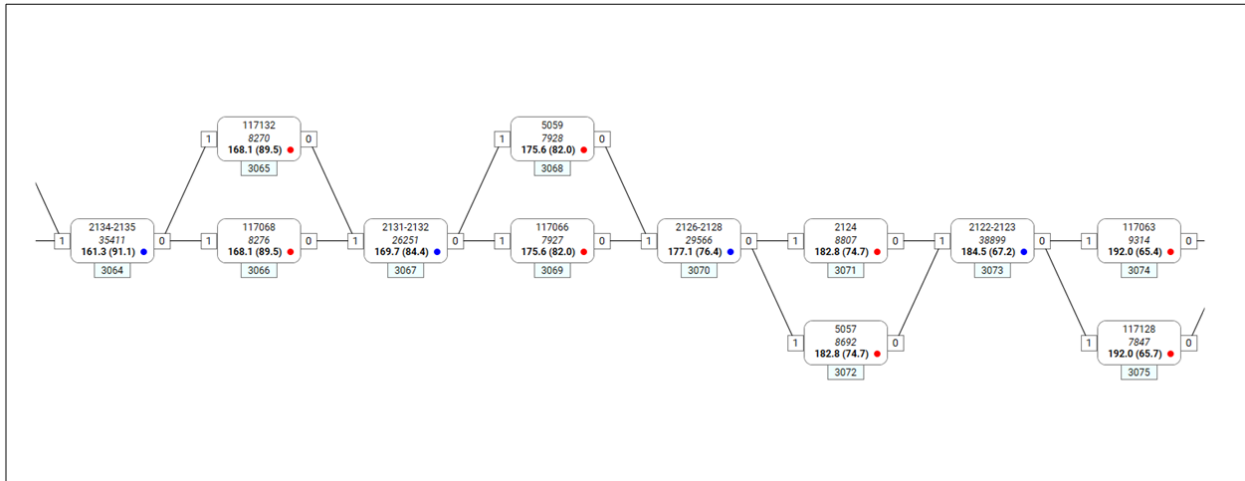
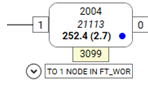

Figure D4. Red Rock Subdivision







Appendix E. Communications Failure Logic Flows

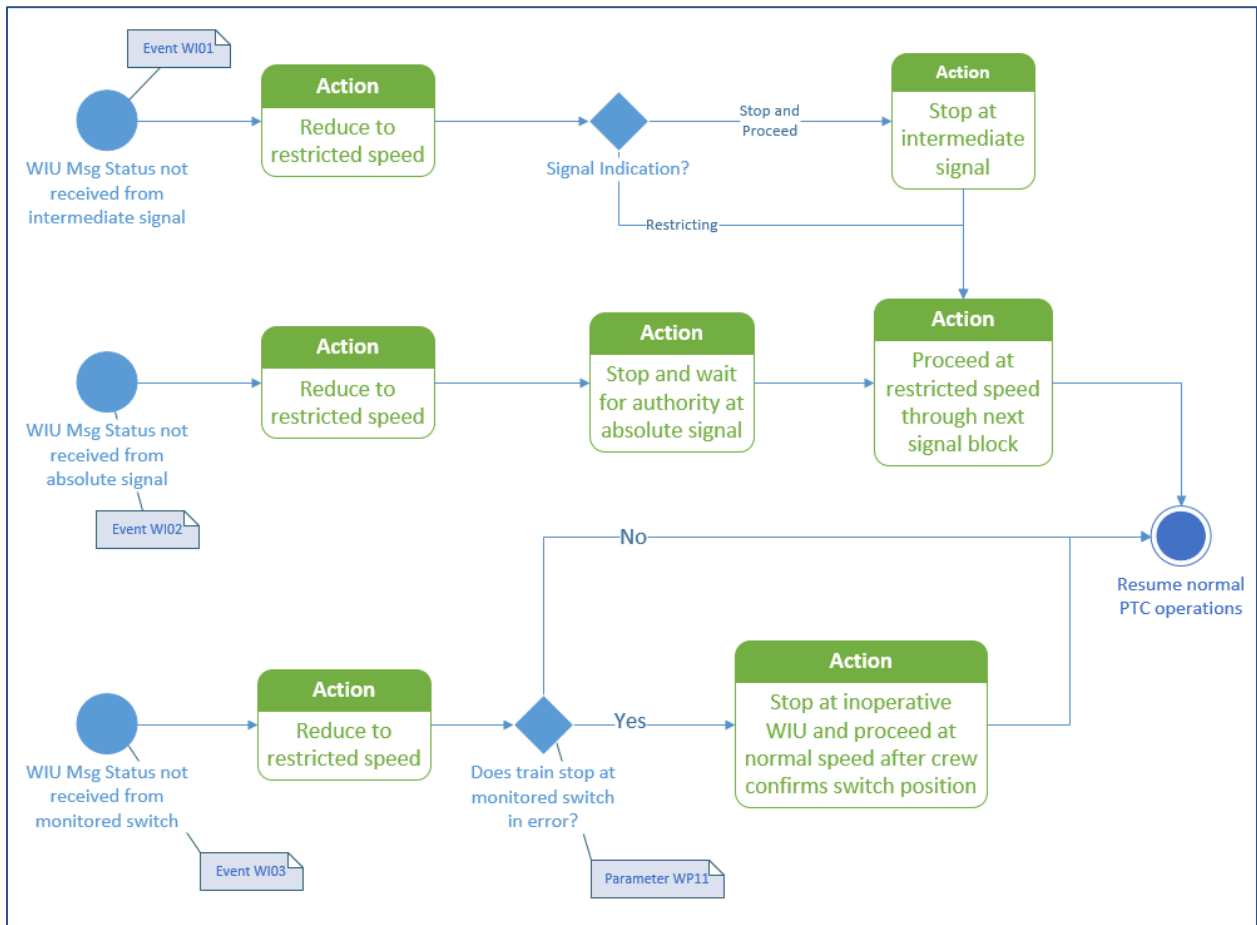

Figure E1. WIU Event Logic Flows

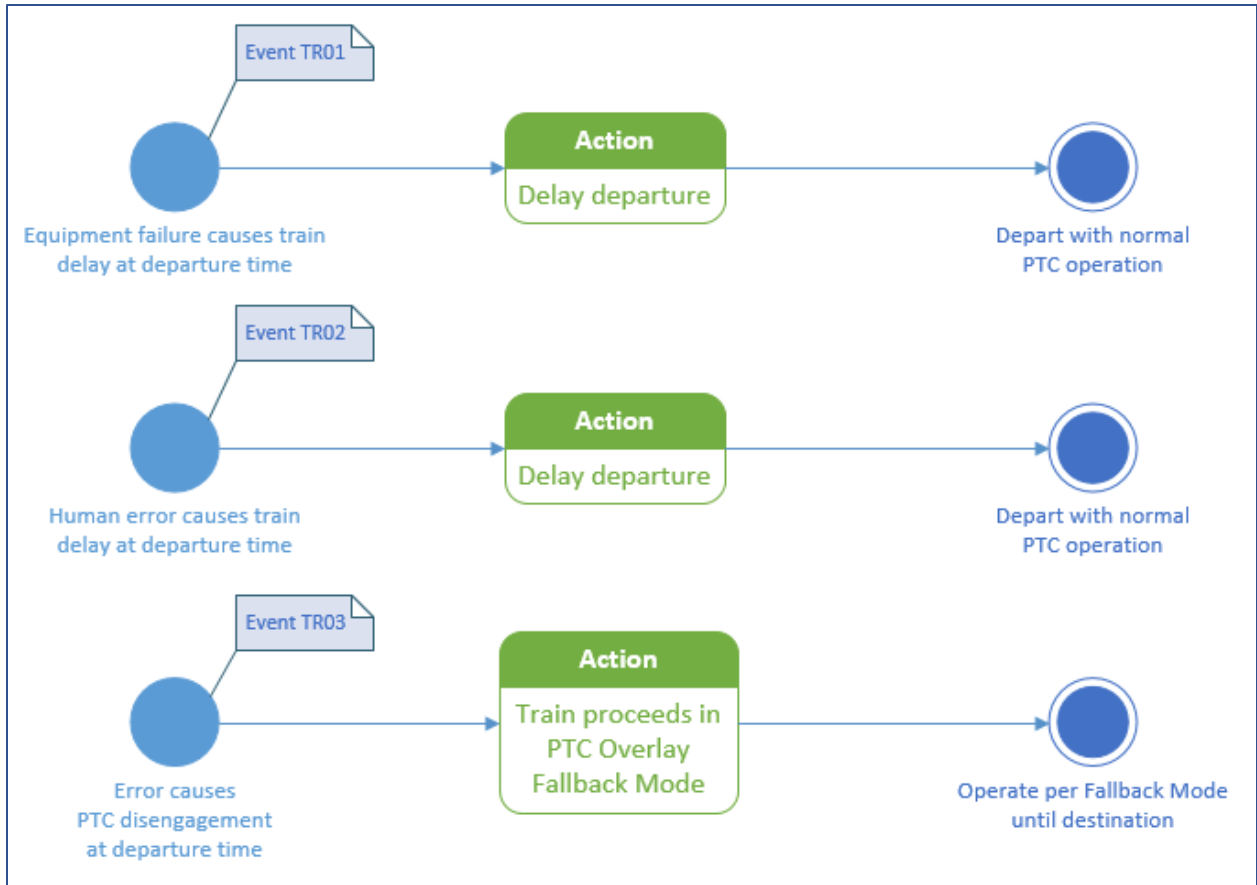

Figure E2. Train Event Logic Flows

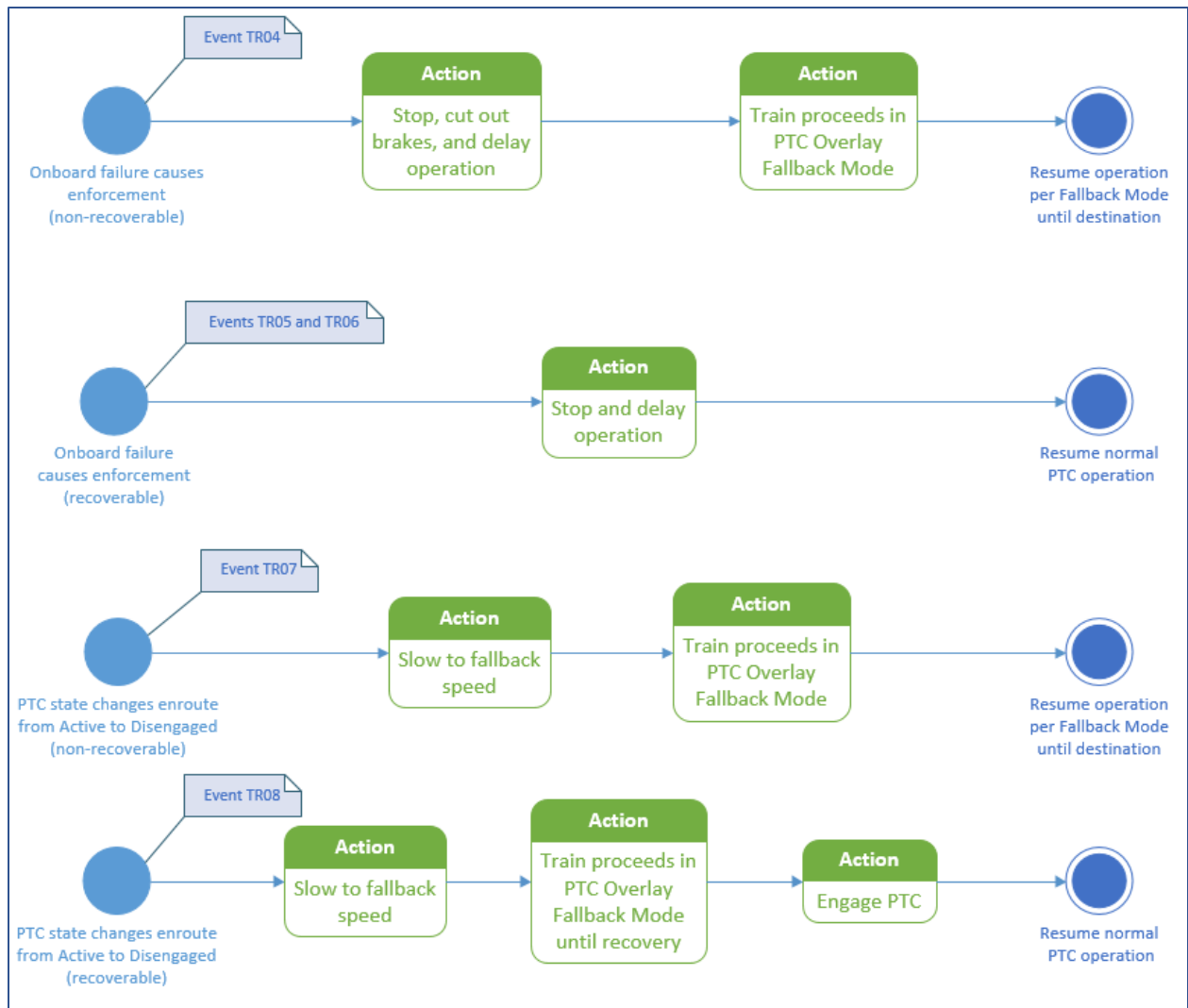

Figure E3. Onboard Computer Events

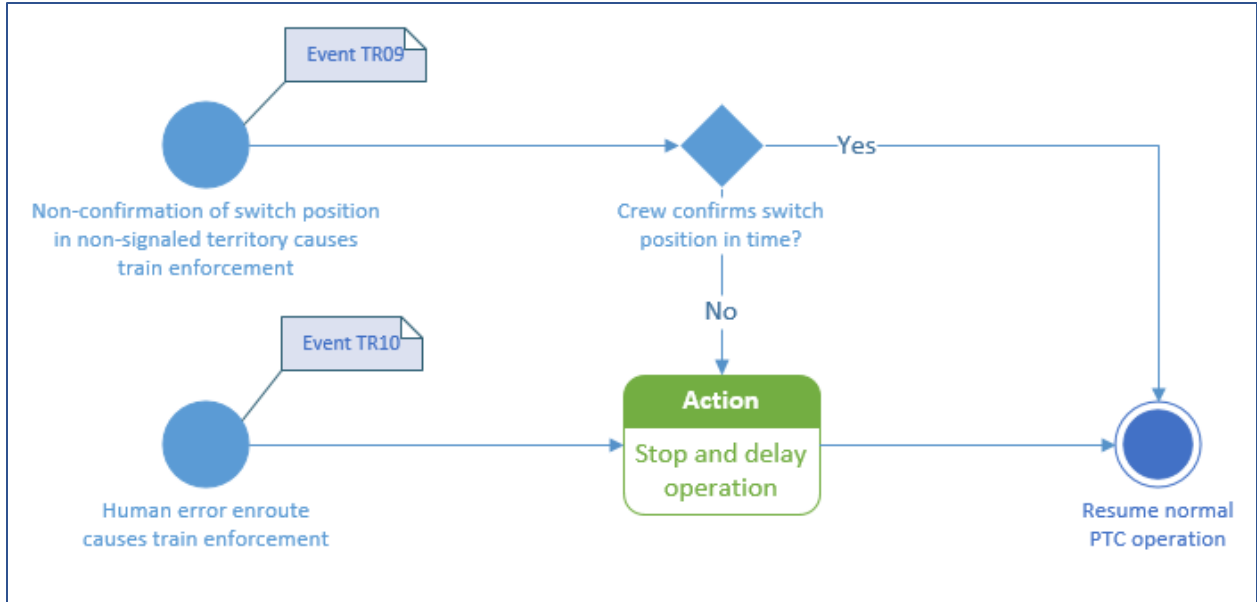

Figure E4. Human Error Enroute Events

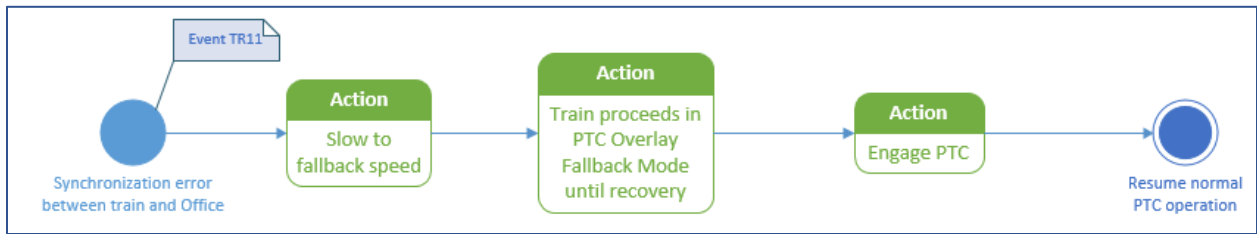

Figure E5. Office Fault Events

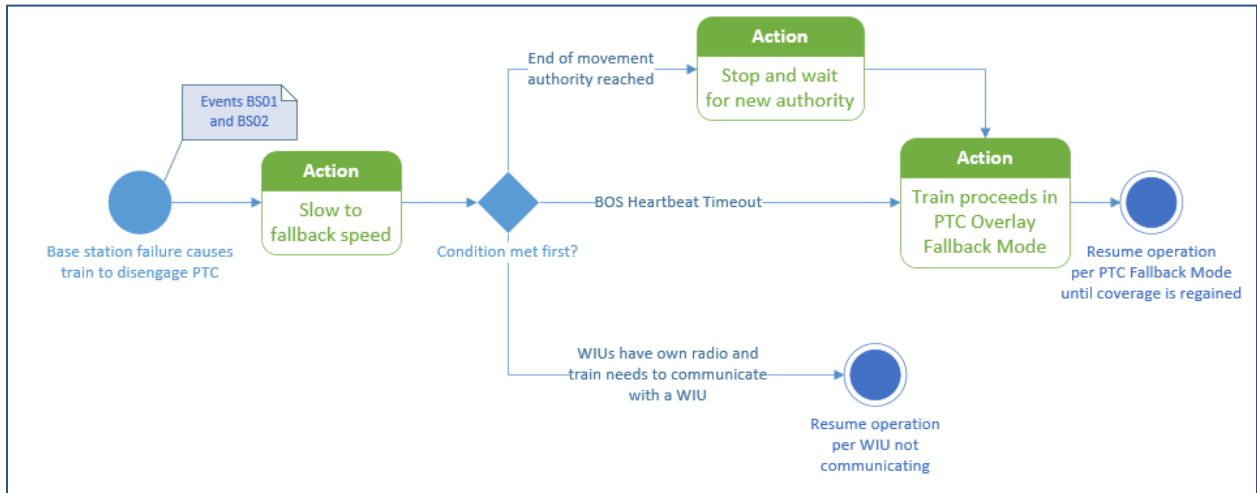

Figure E6. Base Station Events