



U.S. Department
of Transportation

**Federal Railroad
Administration**

Investigation of Cracks in Acela Coach Car Brake Discs: Test and Analysis Volume II - Appendices

Offices of Safety and
Research and Development
Washington, DC 20590



DOT/FRA/ORD-06/07.II

November 30, 2005
Final Report

This document is available to the U.S.
public through the National Technical
Information Service, Springfield, VA

Notice

The United States Government does not endorse products or manufacturers. Trade or manufacturers' names appear herein solely because they are considered essential to the objective of this report.

Notice

This document is disseminated under the sponsorship of the Department of Transportation in the interest of information exchange. The United States Government assumes no liability for its contents or use thereof.

REPORT DOCUMENTATION PAGE

Form Approved
OMB No. 0704-0188

Public reporting burden for this collection of information is estimated to average 1 hour per response, including the time for reviewing instructions, searching existing data sources, gathering and maintaining the data needed, and completing and reviewing this collection of information. Send comments regarding this burden estimate or any other aspect of this collection of information, including suggestions for reducing this burden to Department of Defense, Washington Headquarters Services, Directorate for Information Operations and Reports (0704-0188), 1215 Jefferson Davis Highway, Suite 1204, Arlington, VA 22202-4302. Respondents should be aware that notwithstanding any other provision of law, no person shall be subject to any penalty for failing to comply with a collection of information if it does not display a currently valid OMB control number. **PLEASE DO NOT RETURN YOUR FORM TO THE ABOVE ADDRESS.**

1. REPORT DATE (DD-MM-YYYY) November 30, 2005		2. REPORT TYPE Final	3. DATES COVERED (From - To) April 2005 - November 2005		
4. TITLE AND SUBTITLE Investigation of Cracks in Acela Coach Car Brake Disc: Test and Analysis Volume II – Appendices			5a. CONTRACT NUMBER DTFR-53-02-D-00077 and DTFR53-05-D-00205		
			5b. GRANT NUMBER		
			5c. PROGRAM ELEMENT NUMBER		
6. AUTHOR(S) Sherrock, Eric T.; Owings, Raymond; Clemenzi, Jacinda L.; and Kesler, Kevin			5d. PROJECT NUMBER		
			5e. TASK NUMBER Task 8 and Task 6, respectively		
			5f. WORK UNIT NUMBER		
7. PERFORMING ORGANIZATION NAME(S) AND ADDRESS(ES) ENSCO, Inc. Applied Technology and Engineering Division 5400 Port Royal Road Springfield, VA 22151			8. PERFORMING ORGANIZATION REPORT NUMBER ENSCO-DOT-FR-05-07		
9. SPONSORING / MONITORING AGENCY NAME(S) AND ADDRESS(ES) U.S. Department of Transportation Federal Railroad Administration Office of Research and Development 1120 Vermont Avenue, NW - Mail Stop 20 Washington, DC 20590			10. SPONSOR/MONITOR'S ACRONYM(S)		
			11. SPONSOR/MONITOR'S REPORT NUMBER(S) DOT/FRA/ORD-06/07.II		
12. DISTRIBUTION / AVAILABILITY STATEMENT This document is available to the public through the National Technical Information Service, Springfield, VA 22161. This document is also available on the FRA web site at www.fra.dot.gov .					
13. SUPPLEMENTARY NOTES					
14. ABSTRACT In April 2005, visual and laboratory tests identified cracks in the spokes of several brake discs on coach cars within Amtrak's Acela trainsets, the high-speed trainsets operating on the Northeast Corridor. Amtrak halted operations of the Acela fleet until an assessment of the cracked spokes could be made. With the support of the Federal Railroad Administration, Amtrak launched an extensive test program that relied on a cooperative effort between several organizations, including the Northeast Corridor Maintenance Services Company, Bombardier, Alstom Transportation, the manufacturers of the brake system, and ENSCO, Inc. The test program involved a three-phase over-the-road test effort, finite element analyses, and a series of laboratory tests. The first and second phases focused on characterizing the mechanical and thermal load environment associated with WABTEC/SAB-WABCO supplied brake discs employed on the Acela equipment. In the third phase, the Knorr Brake Corporation provided a replacement disc, and an axle equipped with brake discs of this alternative design was also evaluated. This report documents the background of this issue, as well as the development and implementation of the study. The results of the test program, also detailed in this report, allowed for the identification of the Knorr brake disc as an acceptable alternative to the WABTEC/SAB-WABCO supplied disc, enabling Amtrak to return the Acela fleet to service.					
15. SUBJECT TERMS Brake disc, cracked spoke, Acela brake disc, center and outer brake discs, WABTEC/SAB-WABCO supplied brake disc, Knorr brake disc, out-of-plane bending, in-plane bending, analysis and testing of brake discs					
16. SECURITY CLASSIFICATION OF:			17. LIMITATION OF ABSTRACT Unlimited	18. NUMBER OF PAGES 693	19a. NAME OF RESPONSIBLE PERSON
a. REPORT Unclassified	b. ABSTRACT Unclassified	c. THIS PAGE Unclassified			19b. TELEPHONE NUMBER (include area code)

Standard Form 298 (Rev. 8-98)
Prescribed by ANSI Std. Z39.18

METRIC/ENGLISH CONVERSION FACTORS

ENGLISH TO METRIC

METRIC TO ENGLISH

<p>LENGTH (APPROXIMATE)</p> <p>1 inch (in) = 2.5 centimeters (cm) 1 foot (ft) = 30 centimeters (cm) 1 yard (yd) = 0.9 meter (m) 1 mile (mi) = 1.6 kilometers (km)</p>	<p>LENGTH (APPROXIMATE)</p> <p>1 millimeter (mm) = 0.04 inch (in) 1 centimeter (cm) = 0.4 inch (in) 1 meter (m) = 3.3 feet (ft) 1 meter (m) = 1.1 yards (yd) 1 kilometer (km) = 0.6 mile (mi)</p>
<p>AREA (APPROXIMATE)</p> <p>1 square inch (sq in, in²) = 6.5 square centimeters (cm²) 1 square foot (sq ft, ft²) = 0.09 square meter (m²) 1 square yard (sq yd, yd²) = 0.8 square meter (m²) 1 square mile (sq mi, mi²) = 2.6 square kilometers (km²) 1 acre = 0.4 hectare (ha) = 4,000 square meters (m²)</p>	<p>AREA (APPROXIMATE)</p> <p>1 square centimeter (cm²) = 0.16 square inch (sq in, in²) 1 square meter (m²) = 1.2 square yards (sq yd, yd²) 1 square kilometer (km²) = 0.4 square mile (sq mi, mi²) 10,000 square meters (m²) = 1 hectare (ha) = 2.5 acres</p>
<p>MASS - WEIGHT (APPROXIMATE)</p> <p>1 ounce (oz) = 28 grams (gm) 1 pound (lb) = 0.45 kilogram (kg) 1 short ton = 2,000 pounds (lb) = 0.9 tonne (t)</p>	<p>MASS - WEIGHT (APPROXIMATE)</p> <p>1 gram (gm) = 0.036 ounce (oz) 1 kilogram (kg) = 2.2 pounds (lb) 1 tonne (t) = 1,000 kilograms (kg) = 1.1 short tons</p>
<p>VOLUME (APPROXIMATE)</p> <p>1 teaspoon (tsp) = 5 milliliters (ml) 1 tablespoon (tbsp) = 15 milliliters (ml) 1 fluid ounce (fl oz) = 30 milliliters (ml) 1 cup (c) = 0.24 liter (l) 1 pint (pt) = 0.47 liter (l) 1 quart (qt) = 0.96 liter (l) 1 gallon (gal) = 3.8 liters (l) 1 cubic foot (cu ft, ft³) = 0.03 cubic meter (m³) 1 cubic yard (cu yd, yd³) = 0.76 cubic meter (m³)</p>	<p>VOLUME (APPROXIMATE)</p> <p>1 milliliter (ml) = 0.03 fluid ounce (fl oz) 1 liter (l) = 2.1 pints (pt) 1 liter (l) = 1.06 quarts (qt) 1 liter (l) = 0.26 gallon (gal) 1 cubic meter (m³) = 36 cubic feet (cu ft, ft³) 1 cubic meter (m³) = 1.3 cubic yards (cu yd, yd³)</p>
<p>TEMPERATURE (EXACT)</p> <p>$[(x-32)(5/9)]\text{ }^{\circ}\text{F} = y\text{ }^{\circ}\text{C}$</p>	<p>TEMPERATURE (EXACT)</p> <p>$[(9/5)y + 32]\text{ }^{\circ}\text{C} = x\text{ }^{\circ}\text{F}$</p>

QUICK INCH - CENTIMETER LENGTH CONVERSION

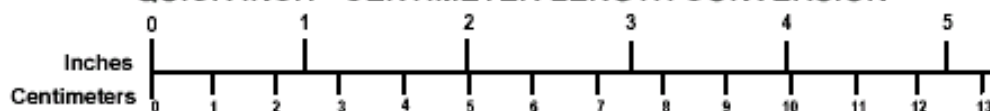

QUICK FAHRENHEIT - CELSIUS TEMPERATURE CONVERSION

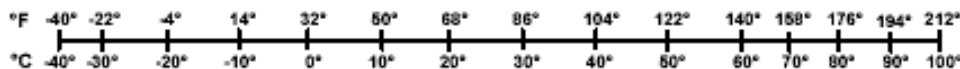

For more exact and/or other conversion factors, see NIST Miscellaneous Publication 286, Units of Weights and Measures. Price \$2.50 SD Catalog No. C13 10286

Updated 6/17/92

TABLE OF CONTENTS

Appendix A. Test Plans Log (Test Plans Provided on CD-ROM).....	A-1
Appendix B. Instrumentation Suite.....	B-1
Appendix C. Data Descriptions	C-1
Appendix D. Test Documents and Logs	D-1
Appendix E. Finite Element Analysis Results.....	E-1
Appendix F. Accelerations	F-1
Appendix G. Spoke Strains	G-1
Appendix H. Axle Strains	H-1
Appendix I. Temperature.....	I-1
Appendix J. Laboratory Testing	J-1
a. Spreader Bar Test	J-2
b. Press-Off Operation.	J-7
c. Quasi-Static Vibration Test	J-41
Appendix K. Brake Support Links.....	K-1
Appendix L. Daily Handouts (Electronic Copies Provided on CD-ROM).....	-
Appendix M. Background of the WABTEC/SAB-WABCO Brake Disc.....	M-1
Technical Definitions	
Acronyms and Abbreviations	

Appendix A. Record of Test Plans

A total of eight test runs were made during the over-the-road portion of the test program. Table A.1 provides a summary of the test runs made.

Table A.1. Summary of Test Plans in Effect During Acela Brake Disc Test Effort

Date of Test	Test Day	Start	End	Speed/Cant Deficiency (Inches)	Test Plan Revision Number
5/14/2005 ⁽¹⁾	-	Washington Wilmington	Wilmington Washington	7	“Combined Test Program to Quantify the Acela Coach Brake Disc Dynamic Load Environment and Monitor Carbody and Truck Motion of Acela Coaches with Simulated Broken Traction Rods,” Revision 5, May 11, 2005
5/16/2005	1	Washington	Boston	7	Revision 5.1 Modification 1
5/17/2005	2	Boston	Washington	7	Revision 5.1 Modification 1
5/26/2005	3	Washington	Boston	7	Revision 6.1
5/27/2005	4	Boston	Washington	7	Revision 6.1
6/16/2005	5	Washington New York	New York Washington	7	Revision 8.0
6/17/2005	6	Washington	Boston	9	Revision 8.0
6/18/2005	7	Boston	Washington	9	Revision 8.0

⁽¹⁾ Shakedown Run

Test Plans are available on CD-ROM upon request. Please direct requests to the following:

ENSCO, Inc.
ATE Division
5400 Port Royal Road
Springfield, VA 22151

Telephone: 703-321-4475

Appendix D provides logs generated during each of these test runs.

Appendix B.*

Instrumentation Suite

May 16 2005

CH	SCU	CAB	S	C	Name	Description	Location	Range	MODEL	SERIAL				
									#	#				
0	0	2	1		CTRSPKF1	Strain Gage	Center Rotor				+/-5Vdc	5B38-02	gf=2.03	5911.33 uStrain
1	1	1	2		CTRSPKF2	Strain Gage	Center Rotor				+/-5Vdc	5B38-02	gf=2.03	5911.33 uStrain
2	2	3	3		CTRSPKR1	Strain Gage	Center Rotor				+/-5Vdc	5B38-02	gf=2.03	5911.33 uStrain
3	3	4	4		CTRSPKR2	Strain Gage	Center Rotor				+/-5Vdc	5B38-02	gf=2.03	5911.33 uStrain
4	4	5			OUTSPKF1	Strain Gage	Outer Rotor				+/-5Vdc	5B38-02	gf=2.03	5911.33 uStrain
5	5	6			OUTSPKF2	Strain Gage	Outer Rotor				+/-5Vdc	5B38-02	gf=2.03	5911.33 uStrain
6	6	7			OUTSPKR1	Strain Gage	Outer Rotor				+/-5Vdc	5B38-02	gf=2.03	5911.33 uStrain
7	7	8			OUTSPKR2	Strain Gage	Outer Rotor				+/-5Vdc	5B38-02	gf=2.03	5911.33 uStrain
8	8	9			CTRSPKTEMP	Thermocouple, Spoke	Center Rotor	32-1832F	Omega		0-5Vdc	5B47-K-04		0.002778 v/deg f
9	9	10			CTRTRTEMPL	Temperature of Braking Surface, Infrared Sensor	Center Rotor	0-1600F	Omega		0-5Vdc	5B41-02		0.003125 v/deg f
10	10	11			CTRTRTEMPR	Temperature of Braking Surface, Infrared Sensor	Center Rotor	0-1600F	Omega		0-5Vdc	5B41-02		0.003125 v/deg f
11	11	12			OUTRTRTEMPL	Temperature of Braking Surface, Infrared Sensor	Outer Rotor	0-1600F	Omega		0-5Vdc	5B41-02		0.003125 v/deg f
12	12	13			OUTRTRTEMPR	Temperature of Braking Surface, Infrared Sensor	Outer Rotor	0-1600F	Omega		0-5Vdc	5B41-02		0.003125 v/deg f
13	13	14			SPEED	Speed; sine from encoder	slip ring	+/-5v	michigan scientific		+/-5Vdc	5B41-02		
15	15				SPARE	spare						5B41-02		
14	14	15	5		AXLELAT	Lateral Acceleration, Axle Mounted	Axle	+/-200g	Silicon Design	2410-200	07133	+/-5Vdc	5B41-02	19.7 mV/G
16	0	1	6		LBOXLAT	Lateral Acceleration, Axle	Axle Box Left	+/-200g	Kistler	8786A200r	C196141	+/-2.5Vdc	5B41-02	9.57 mV/G
17	1	2	7		LBOXVERT	Vertical Acceleration, Axle	Axle Box Left	+/-500g	Kistler	8702B500	2009710	+/-2.5Vdc	5B41-02	10.25 mV/G
18	2	1	9		RBOXLAT	Lateral Acceleration, Axle	Axle Box Right	+/-200g	Silicon Design	2430-200	486	+/-5Vdc	5B41-02	x 50 mV/G
19	3	2	8		RBOXVERT	Vertical Acceleration, Axle	Axle Box Right	+/-200g	Silicon Design	2430-200	486	+/-5Vdc	5B41-02	z 50 mV/G
20	4	1	10		CTRCALPLAT	Lateral Acceleration, Caliper, Near Pad	Center Caliper	+/-100g	Silicon Design	2440-100	0005	+/-5Vdc	5B41-02	50 mV/G
21	5	2	11		CTRCALPVERT	Vertical Acceleration, Caliper, Near Pad	Center Caliper	+/-100g	Silicon Design	2440-100	0005	+/-5Vdc	5B41-02	50 mV/G
22	6	3	12		CTRCALPLONG	Longitudinal Acceleration, Caliper, Near Pad	Center Caliper	+/-100g	Silicon Design	2440-100	0005	+/-5Vdc	5B41-02	50 mV/G
23	7	1			CTRCALALAT	Lateral Acceleration, Caliper, Near Actuator	Center Caliper	+/-100g	Silicon Design	2440-100	0006	+/-5Vdc	5B41-02	50 mV/G
24	8	3			CTRCALAVERT	Vertical Acceleration, Caliper, Near Actuator	Center Caliper	+/-100g	Silicon Design	2440-100	0006	+/-5Vdc	5B41-02	50 mV/G
25	9	2			CTRCALALONG	Longitudinal Acceleration, Caliper, Near Actuator	Center Caliper	+/-100g	Silicon Design	2440-100	0006	+/-5Vdc	5B41-02	50 mV/G
26	10	1			OUTCALPLAT	Lateral Acceleration, Caliper, Near Pad	Outer Caliper	+/-100g	Silicon Design	2440-100	0012	+/-5Vdc	5B41-02	50 mV/G
27	11	2			OUTCALPVERT	Vertical Acceleration, Caliper, Near Pad	Outer Caliper	+/-100g	Silicon Design	2440-100	0012	+/-5Vdc	5B41-02	50 mV/G
28	12	3			OUTCALPLONG	Longitudinal Acceleration, Caliper, Near Pad	Outer Caliper	+/-100g	Silicon Design	2440-100	0012	+/-5Vdc	5B41-02	50 mV/G
29	13	30			PIPEPRESS	Brake Pipe Pressure		0-200 psi	Omega	px41c1-200	148187	0-2.5V	5B41-07	0.012508 V/PSI
30	14	31			CYLPRESS	Brake Cylinder Pressure	Center Caliper	0-200 psi	Omega	px41c1-200	148202	0-2.5V	5B41-07	0.0125 V/PSI
31	15	32			PARKPRESS	Brake Park Pressure	Center Caliper	0-200 psi	Omega	px41c1-200	148201	0-2.5V	5B41-07	0.012498 V/PSI

CH	SCU	CAB	S	C	Name	Description	Location	Range	MODEL #	SERIAL #		inv N	shunt			
0	0	2	1		CTRSPKF1	Strain Gage	Center Rotor				+/-5Vdc	5B38-02	gf=2.03	5911.33 uStrain		2955.682 uStrain max
1	1	1	2		CTRSPKF2	Strain Gage	Center Rotor				+/-5Vdc	5B38-02	gf=2.03	5911.33 uStrain		2955.682 uStrain max
2	2	3	3		CTRSPKR1	Strain Gage	Center Rotor				+/-5Vdc	5B38-02	gf=2.03	5911.33 uStrain		2955.682 uStrain max
3	3	4	4		CTRSPKR2	Strain Gage	Center Rotor				+/-5Vdc	5B38-02	gf=2.03	5911.33 uStrain		2955.682 uStrain max
4	4	5			OUTSPKF1	Strain Gage	Outer Rotor				+/-5Vdc	5B38-02	gf=2.03	5911.33 uStrain		2955.682
5	5	6			OUTSPKF2	Strain Gage	Outer Rotor				+/-5Vdc	5B38-02	gf=2.03	5911.33 uStrain		2955.682
6	6	7			OUTSPKR1	Strain Gage	Outer Rotor				+/-5Vdc	5B38-02	gf=2.03	5911.33 uStrain		2955.682
7	7	8			OUTSPKR2	Strain Gage	Outer Rotor				+/-5Vdc	5B38-02	gf=2.03	5911.33 uStrain		2955.682
8	8	9			CTRDSKTEMP	Thermocouple, Spoke	Center Rotor	32-1832F Omega			0-5Vdc	5B47-K-04		0.002778 v/deg f	360	1800
9	9	10			CTRRTRTEMPL	Temperature of Braking Surface, Infrared Sensor	Center Rotor	0-1600F Omega			0-5Vdc	5B41-02		0.003125 v/deg f	320	1600
10	10	11			CTRRTRTEMPR	Temperature of Braking Surface, Infrared Sensor	Center Rotor	0-1600F Omega			0-5Vdc	5B41-02		0.003125 v/deg f	320	1600
11	11	12			OUTRTRTEMPL	Temperature of Braking Surface, Infrared Sensor	Outer Rotor	0-1600F Omega			0-5Vdc	5B41-02		0.003125 v/deg f	320	1600
12	12	13			OUTRTRTEMPR	Temperature of Braking Surface, Infrared Sensor	Outer Rotor	0-1600F Omega			0-5Vdc	5B41-02		0.003125 v/deg f	320	1600
13	13	14			SPEED	Speed; sine from encoder	slip ring	+/-5v michigan scientific			+/-5Vdc	5B41-02				
15	15				SPARE	spare						5B41-02				
14	14	15	5		AXLELAT	Lateral Acceleration, Axle Mounted	Axle	+/-200g Silicon Design	2410-200	07133	+/-5Vdc	5B41-02		19.7 mV/G		0.0508
16	0	1	6		LBOXLAT	Lateral Acceleration, Axle	Axle Box Left	+/-250g PCB	J353B01	95259	+/-2.5Vdc	5B41-02		10 mV/G		0.1000
17	1	2	7		LBOXVERT	Vertical Acceleration, Axle	Axle Box Left	+/-250g PCB	J353B01	95604	+/-2.5Vdc	5B41-02		10 mV/G		0.1000
18	2	1	9		RBOXLAT	Lateral Acceleration, Axle	Axle Box Right	+/-200g Silicon Design	2430-200	486	+/-5Vdc	5B41-02	x	50 mV/G		0.0200
19	3	2	8		RBOXVERT	Vertical Acceleration, Axle	Axle Box Right	+/-200g Silicon Design	2430-200	486	+/-5Vdc	5B41-02	z	50 mV/G		0.0200
20	4	1	10		CTRCALPLAT	Lateral Acceleration, Caliper, Near Pad	Center Caliper	+/-100g Silicon Design	2440-100	0005	+/-5Vdc	5B41-02		50 mV/G		0.0200
21	5	2	11		CTRCALPVERT	Vertical Acceleration, Caliper, Near Pad	Center Caliper	+/-100g Silicon Design	2440-100	0005	+/-5Vdc	5B41-02		50 mV/G		0.0200
22	6	3	12		CTRCALPLONG	Longitudinal Acceleration, Caliper, Near Pad	Center Caliper	+/-100g Silicon Design	2440-100	0005	+/-5Vdc	5B41-02		50 mV/G		0.0200
23	7	1			CTRCALALAT	Lateral Acceleration, Caliper, Near Actuator	Center Caliper	+/-100g Silicon Design	2440-100	0006	+/-5Vdc	5B41-02		50 mV/G		0.0200
24	8	3			CTRCALAVERT	Vertical Acceleration, Caliper, Near Actuator	Center Caliper	+/-100g Silicon Design	2440-100	0006	+/-5Vdc	5B41-02		50 mV/G		0.0200
25	9	2			CTRCALALONG	Longitudinal Acceleration, Caliper, Near Actuator	Center Caliper	+/-100g Silicon Design	2440-100	0006	+/-5Vdc	5B41-02		50 mV/G		0.0200
26	10	1			OUTCALPLAT	Lateral Acceleration, Caliper, Near Pad	Outer Caliper	+/-100g Silicon Design	2440-100	0012	+/-5Vdc	5B41-02		50 mV/G		0.0200
27	11	2			OUTCALPVERT	Vertical Acceleration, Caliper, Near Pad	Outer Caliper	+/-100g Silicon Design	2440-100	0012	+/-5Vdc	5B41-02		50 mV/G		0.0200
28	12	3			OUTCALPLONG	Longitudinal Acceleration, Caliper, Near Pad	Outer Caliper	+/-100g Silicon Design	2440-100	0012	+/-5Vdc	5B41-02		50 mV/G		0.0200
29	13	30			PIPEPRESS	Brake Pipe Pressure		0-200 psi Omega	px41c1-200	148187	0-2.5V	5B41-07		0.012508 V/PSI		79.9464
30	14	31			CYLPRESS	Brake Cylinder Pressure	Center Caliper	0-200 psi Omega	px41c1-200	148202	0-2.5V	5B41-07		0.0125 V/PSI		80.0000
31	15	32			PARKPRESS	Brake Park Pressure	Center Caliper	0-200 psi Omega	px41c1-200	148201	0-2.5V	5B41-07		0.012498 V/PSI		80.0160

* Note - channels 1 and 2 on SCU1 were swapped 5/14/2005 after the test run

										mike data		SLIP collec HIGH				MODEL	SERIAL					
CH	SCU	File	CAB	S	C	RING	cable	SP	Name	Description	Location	Range			#	#						
0	0	1	2	1	1				CTRSPK6F1	Strain Gage	Center Rotor R6						+/-5Vdc	5B38-02	gf=2.03	5911.330049	uStrain	
1	1	2	1	2	1				CTRSPK6F2	Strain Gage	Center Rotor R6						+/-5Vdc	5B38-02	gf=2.03	5911.330049	uStrain	
2	2	3	3	3	1	8	6		CTRSPK6R1	Strain Gage	Center Rotor R6						+/-5Vdc	5B38-02	gf=2.03	5911.330049	uStrain	
3	3	4	4	4	1		7		CTRSPK6R2	Strain Gage	Center Rotor R6						+/-5Vdc	5B38-02	gf=2.03	5911.330049	uStrain	
4	4	5			2	9	8		CTRSPK3R1	Strain Gage	Center Rotor R3						+/-5Vdc	5B38-02	gf=2.03	5911.330049	uStrain	
5	5	6			2		9		CTRSPK3R2	Strain Gage	Center Rotor R3						+/-5Vdc	5B38-02	gf=2.03	5911.330049	uStrain	
6	6	7			2	10	10		AXLECSPK6	Strain Gage	axle ; center Rot						+/-5Vdc	5B38-02	gf=2.03	5911.330049	uStrain	
7	7	8			2		11		AXLECSPK3	Strain Gage	axle ; center Rot						+/-5Vdc	5B38-02	gf=2.03	5911.330049	uStrain	
8	8	9			2	11	12		AXLEOSPK6	Strain Gage	Axle: 1/4						+/-5Vdc	5B38-02	gf=2.03	5911.330049	uStrain	
9	9	10			2		13		AXLEOSPK3	Strain Gage	Axle: 1/4						+/-5Vdc	5B38-02	gf=2.03	5911.330049	uStrain	
10	10	11	9		1	12			CTRDSKTEMP	Thermocouple, Rotor	Center Rotor	32-1832F	Omega				0-5Vdc	5B47-K-04		0.002777778	v/deg f	
11	11	12	10						CTRRTRTEMP	Temperature of Braking Surface, Infrared Sensor	Center Rotor	0-1600F	Omega				0-5Vdc	5B41-02		0.003125	v/deg f	
12	12	13	11						CTRRTRTEMP	Temperature of Braking Surface, Infrared Sensor	Center Rotor	0-1600F	Omega				0-5Vdc	5B41-02		0.003125	v/deg f	
13	13	14	14			4	14		SINE	Speed; sine from encoder	slip ring	+/-5v	michigan scientific				+/-5Vdc	5B41-02				
14	14	16	15	5		5	4		AXLELAT	Lateral Acceleration, Axle Mounted	Axle	+/-200g	Silicon Design	2410-200	07133		+/-5Vdc	5B41-02			19.7	mV/G
15	15								BAD													
16	0	17	1	6			1		LBOXLAT	Lateral Acceleration, Axle	Axle Box Left	+/-250g	PCB	J353B01	95259		+/-2.5Vdc	5B41-02			10	mV/G
17	1	18	2	7			0		LBOXVERT	Vertical Acceleration, Axle	Axle Box Left	+/-250g	PCB	J353B01	95604		+/-2.5Vdc	5B41-02			10	mV/G
18	2	19	1	9			3		RBOXLAT	Lateral Acceleration, Axle	Axle Box Right	+/-250g	PCB	J353B01	97687		+/-2.5Vdc	5B41-02			10	mV/G
19	3	20	2	8			2		RBOXVERT	Vertical Acceleration, Axle	Axle Box Right	+/-250g	PCB	J353B01	97688		+/-2.5Vdc	5B41-02			10	mV/G
20	4	21	1	10			14		CTRCALPLAT	Lateral Acceleration, Caliper, Near Pad	Center Caliper	+/-100g	Silicon Design	2440-100	0005		+/-5Vdc	5B41-02			50	mV/G
21	5	22	2	11			13		CTRCALPVERT	Vertical Acceleration, Caliper, Near Pad	Center Caliper	+/-100g	Silicon Design	2440-100	0005		+/-5Vdc	5B41-02			50	mV/G
22	6	23	3	12					CTRCALPLONG	Longitudinal Acceleration, Caliper, Near Pad	Center Caliper	+/-100g	Silicon Design	2440-100	0005		+/-5Vdc	5B41-02			50	mV/G
23	7	24	1						CTRCALALAT	Lateral Acceleration, Caliper, Near Actuator	Center Caliper	+/-100g	Silicon Design	2440-100	0012		+/-5Vdc	5B41-02			50	mV/G
24	8	25	3						CTRCALAVERT	Vertical Acceleration, Caliper, Near Actuator	Center Caliper	+/-100g	Silicon Design	2440-100	0012		+/-5Vdc	5B41-02			50	mV/G
25	9	26	2						CTRCALALONG	Longitudinal Acceleration, Caliper, Near Actuator	Center Caliper	+/-100g	Silicon Design	2440-100	0012		+/-5Vdc	5B41-02			50	mV/G
26	10	27					6		5 AXLELAT2	Lateral Acceleration, Axle Mounted	Axle	+/-500g	Dytran	3030b4	12361		+/-5Vdc	5B41-02			10.1	mV/G
27	11	28					15		5 SYNC	Synchronization signal	signal generator	+/-4V	0.5hz to 5Hz	5Secs tri			+/-5Vdc	5B41-02			volts	
28	12	29					7		AXLELAT3	Lateral Acceleration, Axle Mounted	Axle	+/-500g	Endeveco	7264b-500			+/-5Vdc	5B41-02	10v ex		0.8	mV/G
29	13	30	30				15		PIPEPRESS	Brake Pipe Pressure		0-200 psi	Omega	px41c1-200	148187		0-2.5V	5B41-07			0.012508375	V/PSI
30	14	31	31						CYLPRESS	Brake Cylinder Pressure	Center Caliper	0-200 psi	Omega	px41c1-200	148202		0-2.5V	5B41-07			0.0125	V/PSI
31	15	32	32						PARKPRESS	Brake Park Pressure	Center Caliper	0-200 psi	Omega	px41c1-200	148201		0-2.5V	5B41-07			0.0124975	V/PSI

CHANNEL 14 AND 15 ARE SWAPPED IN DATA FILE WITH CHANNEL 14 IS CALCULATED SPEED

		display		AXLE-						MODEL		SERIAL		JUMPERS		
CH	SCU	VISHAY ECTRON	ORG CAB	CABLE	SLIPRING	Name	Description	Location	Range	#	#	#	#	SCU		
0	0	na	15		3-2	AXLELAT1-1	Lateral Acceleration, Axle Mounted	Axle	+/-200g	Silicon Des 2410-200	07133	+/-5Vdc	5B41-02	NO OFF	19.7 mV/G	
1	1	na	x pl		3-3	TRFLAT1	Lateral Acceleration, TRUCK FRAME LEFT		+/-25g	Silicon Des 2440-025	0026	+/-5Vdc	5B41-02	NO OFF	197.10 mV/G	
2	2	na	z pu		3-3	TRFLVERT1	Vertical Acceleration, TRUCK FRAME LEFT		+/-25g	Silicon Des 2440-025	0026	+/-5Vdc	5B41-02	NO OFF	199.00 mV/G	
3	3	na	y pr		3-3	TRFLLONG1	Longitudinal Acceleration, TRUCK FRAME LEFT		+/-25g	Silicon Des 2440-025	0026	+/-5Vdc	5B41-02	NO OFF	197.10 mV/G	
4	4	na	x pr		4-3	BRMTLAT1	Lateral Acceleration, BRAKE MOUNTING TUBE		+/-25g	Silicon Des 2440-025	0028	+/-5Vdc	5B41-02	NO OFF	197.00 mV/G	
5	5	na	z pu		4-3	BRMTVERT1	Vertical Acceleration, BRAKE MOUNTING TUBE		+/-25g	Silicon Des 2440-025	0028	+/-5Vdc	5B41-02	NO OFF	198.10 mV/G	
6	6	na			1	SINE1	Speed; sine from encoder	slip ring 1	+/-10Vdc	michigan scientific		+/-10Vdc		NO	1	
7	7	na			2	SINE2	Speed; sine from encoder	slip ring 3	+/-10Vdc	michigan scientific		+/-10Vdc		NO	1	
8	8	na	y pf		4-3	BRMTLONG1	Longitudinal Acceleration, BRAKE MOUNTING TUBE		+/-25g	Silicon Des 2440-025	0028	+/-5Vdc	5B41-02	NO OFF	196.70 mV/G	
9	9	na	1		1	CTRCALPLAT1	Lateral Acceleration, Caliper, Near Pad	Center Caliper	+/-100g	Silicon Des 2440-100	0005	+/-5Vdc	5B41-02	NO OFF	50 mV/G	
10	10	na	2		1	CTRCALPVERT1	Vertical Acceleration, Caliper, Near Pad	Center Caliper	+/-100g	Silicon Des 2440-100	0005	+/-5Vdc	5B41-02	NO OFF	50 mV/G	
11	11	na	3		1	CTRCALPLONG1	Longitudinal Acceleration, Caliper, Near Pad	Center Caliper	+/-100g	Silicon Des 2440-100	0005	+/-5Vdc	5B41-02	NO OFF	50 mV/G	
12	12	na	31		1	CYLPRESS1	Brake Cylinder Pressure	Center Caliper	0-200 psi	Omega px41c1-200g1	148202	0-2.5V	5B41-07	NO OFF	0.0125 V/PSI	
13	13	na	9		1-1	CTRDSKTEMP1	Thermocouple, Rotor	Center Rotor	32-1832F	Omega		0-5Vdc	5B47-K-04	OFF	0.002778 v/ddeg f	
14	14	na				SYNC	Synchronization signal	signal generator	+/-4V	0.5hz to 5Hz 5Secs tri		+/-5Vdc	5B41-02	NO	1	
15	15	na		AXLE2-14	1-2	2-4	AXLELAT2	Lateral Acceleration, Axle Mounted	Axle	+/-500g	VibraMetric 7002hg2k	0902	+/-5Vdc	NO	9.5 mV/G	
16	0	na	x pl		1-3	2	TRFLAT2	Lateral Acceleration, TRUCK FRAME LEFT		+/-25g	Silicon Des 2440-025	0027	+/-5Vdc	5B41-02	NO OFF	196.50 mV/G
17	1	na	z pu		1-3	2	TRFLVERT2	Vertical Acceleration, TRUCK FRAME LEFT		+/-25g	Silicon Des 2440-025	0027	+/-5Vdc	5B41-02	NO OFF	198.40 mV/G
18	2	na	y pr		1-3	2	TRFLLONG2	Longitudinal Acceleration, TRUCK FRAME LEFT		+/-25g	Silicon Des 2440-025	0027	+/-5Vdc	5B41-02	NO OFF	196.90 mV/G
19	3	na	x pr		2-3	2	BRMTLAT2	Lateral Acceleration, BRAKE MOUNTING TUBE		+/-25g	Silicon Des 2440-025	0029	+/-5Vdc	5B41-02	NO OFF	197.00 mV/G
20	4	na	z pu		2-3	2	BRMTVERT2	Vertical Acceleration, BRAKE MOUNTING TUBE		+/-25g	Silicon Des 2440-025	0029	+/-5Vdc	5B41-02	NO OFF	196.90 mV/G
21	5	na	y pf		2-3	2	BRMTLONG2	Longitudinal Acceleration, BRAKE MOUNTING TUBE		+/-25g	Silicon Des 2440-025	0029	+/-5Vdc	5B41-02	NO OFF	196.90 mV/G
22	6	na	1		2	CTRCALPLAT2	Lateral Acceleration, Caliper, Near Pad	Center Caliper	+/-100g	Silicon Des 2440-100	0012	+/-5Vdc	5B41-02	NO OFF	50 mV/G	
23	7	na	2		2	CTRCALPVERT2	Vertical Acceleration, Caliper, Near Pad	Center Caliper	+/-100g	Silicon Des 2440-100	0012	+/-5Vdc	5B41-02	NO OFF	50 mV/G	
24	8	na	3		2	CTRCALPLONG2	Longitudinal Acceleration, Caliper, Near Pad	Center Caliper	+/-100g	Silicon Des 2440-100	0012	+/-5Vdc	5B41-02	NO OFF	50 mV/G	
25	9	na		AXLE2-15	2-4	2	CTRDSKTEMP2	Thermocouple, Rotor	Center Rotor	32-1832F	Omega	0-5Vdc	5B47-K-04	OFF	0.002778 v/ddeg f	
26	10	na			2	2	CYLPRESS2	Brake Cylinder Pressure	Center Caliper	0-200 psi	Omega px41c1-200g10t	0-2.5V	5B41-07	NO OFF	0.0125 V/PSI	
27	11	1-1	2	AXLE1-1	1-1	1-1	CTRSPK6F1	Strain Gage	Center Rotor S6			+/-5Vdc	2120B	NO	5911.33 uStrain	
28	12	1-2	2	1	AXLE1-2	1-1	CTRSPK6F2	Strain Gage	Center Rotor S6			+/-5Vdc	2120B	NO	5911.33 uStrain	
29	13	1-3	3	3	AXLE1-3	1-1	CTRSPK6R1	Strain Gage	Center Rotor S6			+/-5Vdc	2120B	NO	5911.33 uStrain	
30	14	1-4	4	4	AXLE1-4	1-1	CTRSPK6R2	Strain Gage	Center Rotor S6			+/-5Vdc	2120B	NO	5911.33 uStrain	
31	15						BAD						5B41-02	NO		
32	0	1-5	5		AXLE1-5	1-1	1-2	CTRSPK3R1	Strain Gage	Center Rotor S3		+/-5Vdc	2120B	NO	5911.33 uStrain	
33	1	1-6	6		AXLE1-6	1-1	1-2	CTRSPK3R2	Strain Gage	Center Rotor S3		+/-5Vdc	2120B	NO	5911.33 uStrain	
34	2	2-1			AXLE1-7	2-1	1-2	AXLECSPK6	Strain Gage	axle ; center Rot		+/-5Vdc	2120B	NO	5911.33 uStrain	
35	3	2-2			AXLE1-8	2-1	1-2	AXLECSPK3	Strain Gage	axle ; center Rot		+/-5Vdc	2120B	NO	5911.33 uStrain	
36	4	2-3			AXLE1-9	2-1	1-2	AXLEOSPK6	Strain Gage	Axle: 1/4		+/-5Vdc	2120B	NO	5911.33 uStrain	
37	5	2-4			AXLE1-10	2-1	1-2	AXLEOSPK3	Strain Gage	Axle: 1/4		+/-5Vdc	2120B	NO	5911.33 uStrain	
38	6	2-5				1	1	AXLE1LLINK	Strain Gage	Center Caliper		+/-5Vdc	2120B	NO	5911.33 uStrain	
39	7	2-6				1	1	AXLE1RLINK	Strain Gage	Center Caliper		+/-5Vdc	2120B	NO	5911.33 uStrain	
40	8	3-1			AXLE2-1	3-1	2-3	CTR2SPK6R1	Strain Gage	Center Rotor S6 (SG1)		+/-5Vdc	2120B	NO	5911.33 uStrain	
41	9	3-2			AXLE2-2	3-1	2-3	CTR2SPK6R2	Strain Gage	Center Rotor S6 (SG2)		+/-5Vdc	2120B	NO	5911.33 uStrain	
42	10	3-3			AXLE2-3	3-1	2-3	CTR2SPK3R1	Strain Gage	Center Rotor S1 (SG3)		+/-5Vdc	2120B	NO	5911.33 uStrain	
43	11	3-4			AXLE2-4	3-1	2-3	CTR2SPK3R2	Strain Gage	Center Rotor S1 (SG3a)		+/-5Vdc	2120B	NO	5911.33 uStrain	
44	12	3-5			AXLE2-5		2-3	CTR2SPK6_4	Strain Gage	Center Rotor S4 (SG4)		+/-5Vdc	2120B	NO	5911.33 uStrain	
45	13	3-6			AXLE2-6		2-3	CTR2SPK6_5	Strain Gage	Center Rotor S4 (SG5)		+/-5Vdc	2120B	NO	5911.33 uStrain	
46	14	3-7			AXLE2-7		2-3	CTR2SPK4_6	Strain Gage	Center Rotor S4 (SG6)		+/-5Vdc	2120B	NO	5911.33 uStrain	
47	15	4-1			AXLE2-8	4-1	2-4	AXLE2CSPK6	Strain Gage	axle ; center Rot		+/-5Vdc	2120B	NO	5911.33 uStrain	
48	0	4-2			AXLE2-9	4-1	2-4	AXLE2CSPK3	Strain Gage	axle ; center Rot		+/-5Vdc	2120B	NO	5911.33 uStrain	
49	1	4-3			AXLE2-12	4-1	2-4	AXLE2CSPK6+90	Strain Gage	axle ; center Rot		+/-5Vdc	2120B	NO	5911.33 uStrain	
50	2	4-4			AXLE2-13	4-1	2-4	AXLE2CSPK6-90	Strain Gage	axle ; center Rot		+/-5Vdc	2120B	NO	5911.33 uStrain	
51	3	4-5			AXLE2-10	4-1	2-4	AXLE2OSPK6	Strain Gage	Axle: 1/4		+/-5Vdc	2120B	NO	5911.33 uStrain	
52	4	4-5			AXLE2-11	4-1	2-4	AXLE2OSPK3	Strain Gage	Axle: 1/4		+/-5Vdc	2120B	NO	5911.33 uStrain	
53	5	4-6				3-2	1	LBOXLAT1	Lateral Acceleration, Axle	Axle Box Left	+/-100g	PCB J353B01	95259	+/-2.5Vdc	NA	10 mV/G
54	6	na				4-2	1	LBOXVERT1	Vertical Acceleration, Axle	Axle Box Left	+/-250g	PCB J353B01	95604	+/-2.5Vdc	NA	10 mV/G
55	7	na				3-2	1	RBOXLAT1	Lateral Acceleration, Axle	Axle Box Right	+/-100g	PCB J353B01	97687	+/-2.5Vdc	NA	10 mV/G
56	8	na				4-2	1	RBOXVERT1	Vertical Acceleration, Axle	Axle Box Right	+/-250g	PCB J353B01	97688	+/-2.5Vdc	NA	10 mV/G

PIN1=NO OFFSET
PIN3=OFFSET

CH	SCU	VISHAY	ORG	display	AXLE-	Name	Description
57	9	na		1-2	2	LBOXLAT2	Lateral Acceleration, Axle
58	10	na		2-2	2	LBOXVERT2	Vertical Acceleration, Axle
59	11	na		1-2	2	RBOXLAT2	Lateral Acceleration, Axle
60	12	na		2-2	2	RBOXVERT2	Vertical Acceleration, Axle
61	13	na		3-2	1-2	AXLELAT1-2	Lateral Acceleration, Axle Mounted
62	14	na		3-2	1-2	AXLELAT1-3	Lateral Acceleration, Axle Mounted
63	15	na			1	AXLE1LLONG	Long Acc Axle
****						SPEED1	CALCULATED SPEED FOR SINE1

***ANY ADDITIONAL CALCULATED CHANNELS TO BE ADDED AFTER THE AD CHANNELS; THIS IS AND EXAMPLE

Location	Range	MODEL	SERIAL	JUMPERS
		#	#	SCU
Axle Box Left	+/-100g	PCB J353B31	97692	NA 10 mV/G
Axle Box Left	+/-250g	PCB J353B01	95603	NA 10 mV/G
Axle Box Right	+/-100g	PCB J353B31	97690	NA 10 mV/G
Axle Box Right	+/-250g	PCB J353B01	95258	NA 10 mV/G
Axle	+/-500g	VibraMetric 7002hg2k	0867	NA 9.9 mV/G
Axle	+/-500g	Endevco 7264b-500		NA 10 mV/G
Axle	+/-100g	PCB J353B31	97691	NA 10 mV/G

PIN1=NO OFFSET
PIN3=OFFSET

		display		AXLE-		SLIPRING		Name		Description		Location		Range		MODEL		SERIAL		JUMPERS		SCU		
CH	SCU	VISHAY	ORG	CABLE	AXLE-	SLIPRING	Name	Description	Location	Range	MODEL	SERIAL	JUMPERS	SCU	Value	Unit	Value	Unit	Value	Unit	Value	Unit	Value	Unit
0	0	na			3-2	1-1	AXLELAT1-1	Lateral Acceleration, Axle Mounted	Axle	+/-200g	Silicon Des2410-200	07133	+/-5Vdc	5B41-02	NO OFF	19.7	mV/G							
1	1	na	x pl		3-3	1	TRFLLAT1	Lateral Acceleration, TRUCK FRAME LEFT		+/-25g	Silicon Des2440-025	0026	+/-5Vdc	5B41-02	NO OFF	197.10	mV/G							
2	2	na	z pu		3-3	1	TRFLVERT1	Vertical Acceleration, TRUCK FRAME LEFT		+/-25g	Silicon Des2440-025	0026	+/-5Vdc	5B41-02	NO OFF	199.00	mV/G							
3	3	na	y pr		3-3	1	TRFLLONG1	Longitudinal Acceleration, TRUCK FRAME LEFT		+/-25g	Silicon Des2440-025	0026	+/-5Vdc	5B41-02	NO OFF	197.10	mV/G							
4	4	na	x pr		4-3	1	BRMTLAT1	Lateral Acceleration, BRAKE MOUNTING TUBE		+/-25g	Silicon Des2440-025	0028	+/-5Vdc	5B41-02	NO OFF	197.00	mV/G							
5	5	na	z pu		4-3	1	BRMTVERT1	Vertical Acceleration, BRAKE MOUNTING TUBE		+/-25g	Silicon Des2440-025	0028	+/-5Vdc	5B41-02	NO OFF	198.10	mV/G							
6	6	na				1	SINE1	Speed; sine from encoder	slip ring 1	+/-10Vdc	michigan scientific		+/-10Vdc		NO		1							
7	7	na				2	SINE2	Speed; sine from encoder	slip ring 3	+/-10Vdc	michigan scientific		+/-10Vdc		NO		1							
8	8	na	y pf		4-3	1	BRMTLONG1	Longitudinal Acceleration, BRAKE MOUNTING TUBE		+/-25g	Silicon Des2440-025	0028	+/-5Vdc	5B41-02	NO OFF	196.70	mV/G							
9	9	na	1			1	CTRCALPLAT1	Lateral Acceleration, Caliper, Near Pad	Center Caliper	+/-100g	Silicon Des2440-100	0005	+/-5Vdc	5B41-02	NO OFF	50	mV/G							
10	10	na	2			1	CTRCALPVERT1	Vertical Acceleration, Caliper, Near Pad	Center Caliper	+/-100g	Silicon Des2440-100	0005	+/-5Vdc	5B41-02	NO OFF	50	mV/G							
11	11	na	3			1	CTRCALPLONG1	Longitudinal Acceleration, Caliper, Near Pad	Center Caliper	+/-100g	Silicon Des2440-100	0005	+/-5Vdc	5B41-02	NO OFF	50	mV/G							
12	12	na	31			1	CYLPRESS1	Brake Cylinder Pressure	Center Caliper	0-200 psi	Omega px41c1-200g10t	148202	0-2.5V	5B41-07	NO OFF	0.0125	V/PSI							
13	13	na	9			1-1	CTRDSKTEMP1	Thermocouple, Rotor	Center Rotor	32-1832F	Omega		0-5Vdc	5B47-K-04	OFF	0.002778	v/deg f							
14	14	na					SYNC	Synchronization signal	signal generatr	+/-4V	0.5hz to 5Hz 5Secs tri		+/-5Vdc	5B41-02	NO		1							
15	15	na		AXLE2-14	1-2	2-4	AXLELAT2	Lateral Acceleration, Axle Mounted	Axle	+/-500g	VibraMetric 7002hg2k	0902	+/-5Vdc		NO		9.5	mV/G						
16	0	na	x pl		1-3	2	TRFLLAT2	Lateral Acceleration, TRUCK FRAME LEFT		+/-25g	Silicon Des2440-025	0027	+/-5Vdc	5B41-02	NO OFF	196.50	mV/G							
17	1	na	z pu		1-3	2	TRFLVERT2	Vertical Acceleration, TRUCK FRAME LEFT		+/-25g	Silicon Des2440-025	0027	+/-5Vdc	5B41-02	NO OFF	198.40	mV/G							
18	2	na	y pr		1-3	2	TRFLLONG2	Longitudinal Acceleration, TRUCK FRAME LEFT		+/-25g	Silicon Des2440-025	0027	+/-5Vdc	5B41-02	NO OFF	196.90	mV/G							
19	3	na	x pr		2-3	2	BRMTLAT2	Lateral Acceleration, BRAKE MOUNTING TUBE		+/-25g	Silicon Des2440-025	0029	+/-5Vdc	5B41-02	NO OFF	197.00	mV/G							
20	4	na	z pu		2-3	2	BRMTVERT2	Vertical Acceleration, BRAKE MOUNTING TUBE		+/-25g	Silicon Des2440-025	0029	+/-5Vdc	5B41-02	NO OFF	196.90	mV/G							
21	5	na	y pf		2-3	2	BRMTLONG2	Longitudinal Acceleration, BRAKE MOUNTING TUBE		+/-25g	Silicon Des2440-025	0029	+/-5Vdc	5B41-02	NO OFF	196.90	mV/G							
22	6	na	1			2	CTRCALPLAT2	Lateral Acceleration, Caliper, Near Pad	Center Caliper	+/-100g	Silicon Des2440-100	0012	+/-5Vdc	5B41-02	NO OFF	50	mV/G							
23	7	na	2			2	CTRCALPVERT2	Vertical Acceleration, Caliper, Near Pad	Center Caliper	+/-100g	Silicon Des2440-100	0012	+/-5Vdc	5B41-02	NO OFF	50	mV/G							
24	8	na	3			2	CTRCALPLONG2	Longitudinal Acceleration, Caliper, Near Pad	Center Caliper	+/-100g	Silicon Des2440-100	0012	+/-5Vdc	5B41-02	NO OFF	50	mV/G							
25	9	na		AXLE2-15	2-4	2	CTRDSKTEMP2	Thermocouple, Rotor	Center Rotor	32-1832F	Omega		0-5Vdc	5B47-K-04	OFF	0.002778	v/deg f							
26	10	na				2	CYLPRESS2	Brake Cylinder Pressure	Center Caliper	0-200 psi	Omega px41c1-200g10t		0-2.5V	5B41-07	NO OFF	0.0125	V/PSI							
27	11	1-1	2	AXLE1-1	1-1	1-1	CTRSPK6F1	Strain Gage	Center Rotor S6				+/-5Vdc	2120B	NO		4000	uStrain						
28	12	1-2	1	AXLE1-2	1-1	1-1	CTRSPK6F2	Strain Gage	Center Rotor S6				+/-5Vdc	2120B	NO		4000	uStrain						
29	13	1-7	3	AXLE1-3	1-1	1-1	CTRSPK6R1	Strain Gage	Center Rotor S6				+/-5Vdc	2120B	NO		4000	uStrain						
30	14	1-8	4	AXLE1-4	1-1	1-1	CTRSPK6R2	Strain Gage	Center Rotor S6				+/-5Vdc	2120B	NO		4000	uStrain						
31	15						BAD							5B41-02	NO									
32	0	1-5		AXLE1-5	1-1	1-2	CTRSPK3R1	Strain Gage	Center Rotor S3				+/-5Vdc	2120B	NO		4000	uStrain						
33	1	1-6		AXLE1-6	1-1	1-2	CTRSPK3R2	Strain Gage	Center Rotor S3				+/-5Vdc	2120B	NO		4000	uStrain						
34	2	2-1		AXLE1-7	2-1	1-2	AXLECSPK6	Strain Gage	axle ; center Rot				+/-5Vdc	2120B	NO		2000	uStrain						
35	3	2-2		AXLE1-8	2-1	1-2	AXLECSPK3	Strain Gage	axle ; center Rot				+/-5Vdc	2120B	NO		2000	uStrain						
36	4	2-3		AXLE1-9	2-1	1-2	AXLEOSPK6	Strain Gage	Axle: 1/4				+/-5Vdc	2120B	NO		2000	uStrain						
37	5	2-4		AXLE1-10	2-1	1-2	AXLEOSPK3	Strain Gage	Axle: 1/4				+/-5Vdc	2120B	NO		2000	uStrain						
38	6	2-5				1	AXLE1LLINK	Strain Gage	Center Caliper				+/-5Vdc	2120B	NO		3000	uStrain						
39	7	2-6				1	AXLE1RLINK	Strain Gage	Center Caliper				+/-5Vdc	2120B	NO		3000	uStrain						
40	8	3-1		AXLE2-1	3-1	2-3	CTR2SPK6R1	Strain Gage	Center Rotor S6 (SG1)				+/-5Vdc	2120B	NO		4000	uStrain						
41	9	3-2		AXLE2-2	3-1	2-3	CTR2SPK6R2	Strain Gage	Center Rotor S6 (SG2)				+/-5Vdc	2120B	NO		4000	uStrain						
42	10	3-3		AXLE2-3	3-1	2-3	CTR2SPK3R1	Strain Gage	Center Rotor S1 (SG3)				+/-5Vdc	2120B	NO		4000	uStrain						
43	11	3-4		AXLE2-4	3-1	2-3	CTR2SPK3R2	Strain Gage	Center Rotor S1 (SG3a)				+/-5Vdc	2120B	NO		4000	uStrain						
44	12	3-5		AXLE2-5	2-3	2-3	CTR2SPK6_4	Strain Gage	Center Rotor S4 (SG4)				+/-5Vdc	2120B	NO		4000	uStrain						
45	13	3-6		AXLE2-6	2-3	2-3	CTR2SPK6_5	Strain Gage	Center Rotor S4 (SG5)				+/-5Vdc	2120B	NO		4000	uStrain						
46	14	3-7		AXLE2-7	2-3	2-3	CTR2SPK4_6	Strain Gage	Center Rotor S4 (SG6)				+/-5Vdc	2120B	NO		4000	uStrain						
47	15	4-1		AXLE2-8	4-1	2-4	AXLE2CSPK6	Strain Gage	axle ; center Rot				+/-5Vdc	2120B	NO		2000	uStrain						
48	0	4-2		AXLE2-9	4-1	2-4	AXLE2CSPK3	Strain Gage	axle ; center Rot				+/-5Vdc	2120B	NO		2000	uStrain						
49	1	4-3		AXLE2-12	4-1	2-4	AXLE2CSPK6+90	Strain Gage	axle ; center Rot				+/-5Vdc	2120B	NO		2000	uStrain						
50	2	4-4		AXLE2-13	4-1	2-4	AXLE2CSPK6-90	Strain Gage	axle ; center Rot				+/-5Vdc	2120B	NO		2000	uStrain						
51	3	4-5		AXLE2-10	4-1	2-4	AXLE2OSPK6	Strain Gage	Axle: 1/4				+/-5Vdc	2120B	NO		2000	uStrain						
52	4	4-6		AXLE2-11	4-1	2-4	AXLE2OSPK3	Strain Gage	Axle: 1/4				+/-5Vdc	2120B	NO		2000	uStrain						
53	5	na			3-2	1	LBOXLAT1	Lateral Acceleration, Axle	Axle Box Left	+/-100g	PCB J353B01	95259	+/-2.5Vdc		NA		10	mV/G						
54	6	na			4-2	1	LBOXVERT1	Vertical Acceleration, Axle	Axle Box Left	+/-250g	PCB J353B01	95604	+/-2.5Vdc		NA		10	mV/G						
55	7	na			3-2	1	RBOXLAT1	Lateral Acceleration, Axle	Axle Box Right	+/-100g	PCB J353B01	97687	+/-2.5Vdc		NA		10	mV/G						
56	8	na			4-2	1	RBOXVERT1	Vertical Acceleration, Axle	Axle Box Right	+/-250g	PCB J353B01	97688	+/-2.5Vdc		NA		10	mV/G						

PIN1=NO OFFSET
PIN3=OFFSET

CH	SCU	VISHAY	ORG	display	AXLE-	SLIPRING	Name	Description	Location	Range	MODEL	SERIAL	JUMPERS		
		ECTRON	CAB	CABLE							#	#	SCU		
57	9	na		1-2	2	LBOXLAT2	Lateral Acceleration, Axle	Axle Box Left	+/-100g	PCB	J353B31	97692	+/-2.5Vdc	NA	10 mV/G
58	10	na		2-2	2	LBOXVERT2	Vertical Acceleration, Axle	Axle Box Left	+/-250g	PCB	J353B01	95603	+/-2.5Vdc	NA	10 mV/G
59	11	na		1-2	2	RBOXLAT2	Lateral Acceleration, Axle	Axle Box Right	+/-100g	PCB	J353B31	97690	+/-2.5Vdc	NA	10 mV/G
60	12	na		2-2	2	RBOXVERT2	Vertical Acceleration, Axle	Axle Box Right	+/-250g	PCB	J353B01	95258	+/-2.5Vdc	NA	10 mV/G
61	13	na		3-2	1-2	AXLELAT1-2	Lateral Acceleration, Axle Mounted	Axle	+/-500g	VibraMetric	7002hg2k	0867	+/-5Vdc	NA	9.9 mV/G
62	14	na		3-2	1-2	AXLELAT1-3	Lateral Acceleration, Axle Mounted	Axle	+/-500g	Endeveco	7264b-500		+/-5Vdc	NA	10 mV/G
63	15	na			1	AXLE1LLONG	Long Acc Axle		+/-100g	PCB	J353B31	97691	+/-2.5Vdc	NA	10 mV/G
****						SPEED1	CALCULATED SPEED FOR SINE1								

***ANY ADDITIONAL CALCULATED CHANNELS TO BE ADDED AFTER THE AD CHANNELS; THIS IS AND EXAMPLE

**Calibration Certificates
and Specification Sheets
for Sensors Used
During ENSCO's
Acela Brake Disc Test**



Model: 2430-200

CALIBRATION CERTIFICATE

Part #: 153-00007-05 Doc. Rev. D

Mfg. Lot #: 9m095a

Op. Number: 740

	X-Axis	Y-Axis	Z-Axis	
+1 G DC:	33.0	19.0	12.0	mV DC
-1 G DC:	-17.0	-31.0	-38.0	mV DC
0 G Bias	8.0	-6.0	-13.0	mV DC
Scale Factor	25.00	24.90	25.20	mV/G
Sensor ID	62663	62661	62665	

Operator: Jerry

Serial #: 427

Calibration Date: 05/04/05

Supply Current: 26.3 mA

Scale Factor

Full Scale: 200 G

Calibration Freq. 100 Hz

Sensor ID

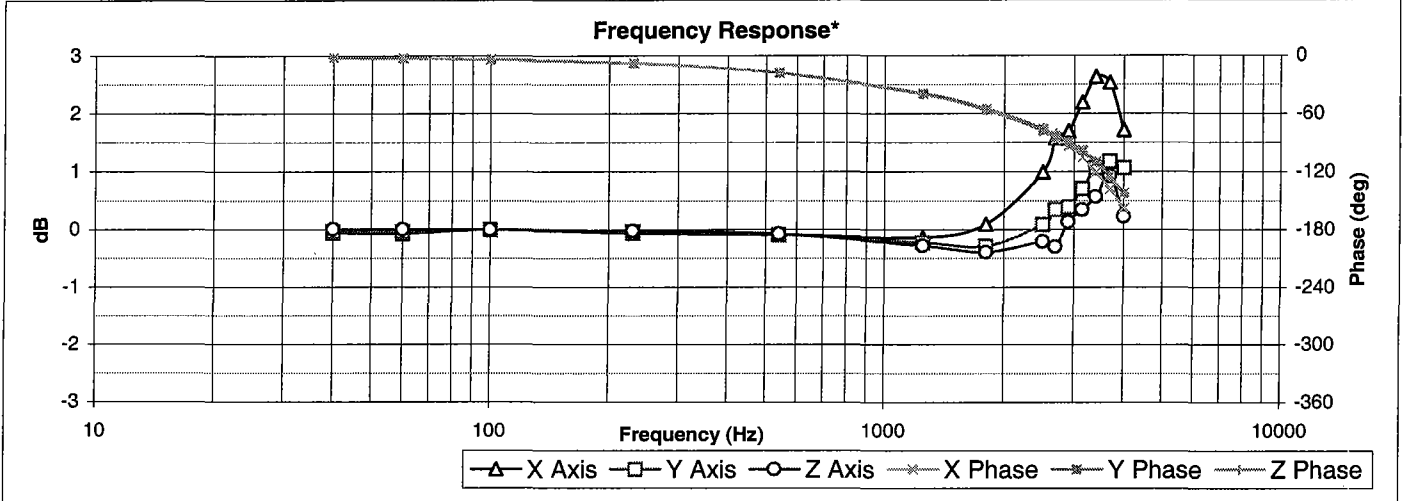
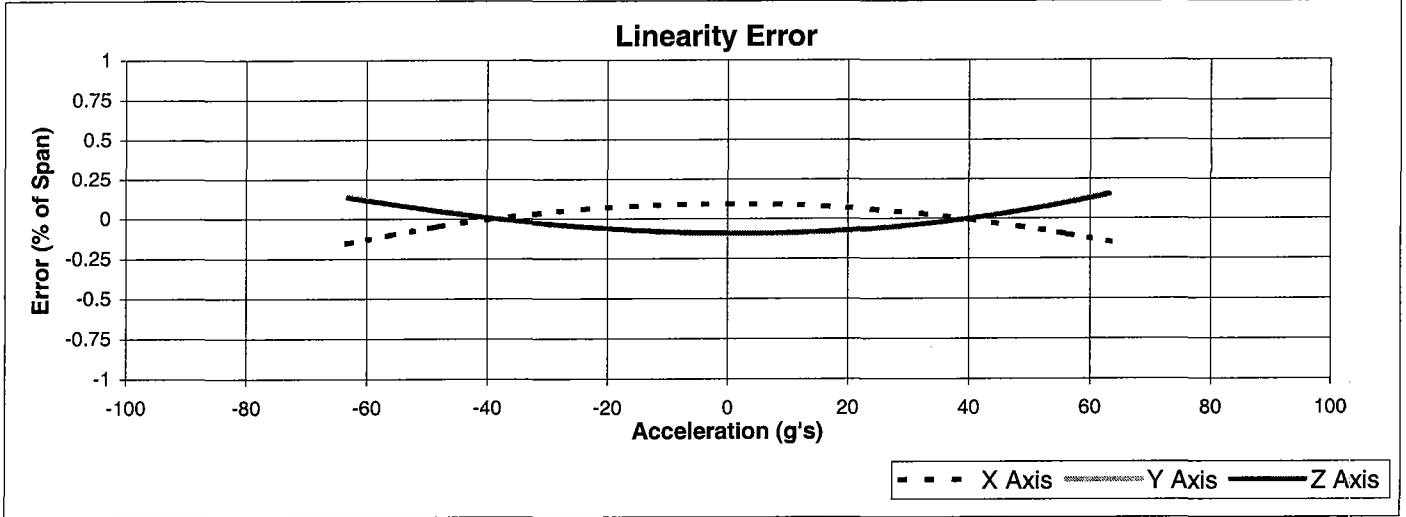

Freq. (Hz)**	40	60	100	230	540	1250	1800	2500	2690	2900	3140	3400	3685	4000
dB Out - X	-0.06	-0.06	0.00	-0.06	-0.09	-0.14	0.09	0.99	1.58	1.70	2.19	2.63	2.53	1.72
Phase (deg)	-2.1	-2.6	-4.0	-7.9	-17.9	-40.1	-56.4	-78.5	-87.4	-93.6	-105.5	-120.4	-137.9	-157.5
Freq. (Hz)**	40	60	100	230	540	1250	1800	2500	2690	2900	3140	3400	3685	4000
dB Out - Y	-0.03	-0.03	0.00	-0.03	-0.09	-0.22	-0.29	0.09	0.35	0.39	0.71	1.07	1.18	1.07
Phase (deg)	-2.0	-2.5	-3.8	-7.7	-17.5	-39.1	-55.2	-75.8	-83.6	-88.9	-98.2	-109.9	-124.0	-141.9
Freq. (Hz)**	40	60	100	230	540	1250	1800	2500	2690	2900	3140	3400	3685	4000
dB Out - Z	0.00	0.01	0.00	-0.02	-0.07	-0.28	-0.39	-0.21	-0.30	0.14	0.34	0.57	0.93	0.23
Phase (deg)	-2.1	-2.6	-3.9	-7.9	-18.0	-40.3	-56.7	-77.5	-81.2	-91.7	-99.9	-110.4	-125.9	-142.6

* Reference Frequency is 100 Hz

** 14.142 g Peak Acceleration Traceable to NIST through Vibration Calibration Standard M-90157

Final Status:

Pass:



CALIBRATION CERTIFICATE PAGE 2

Model: 2430-200 **Part #:** 153-00007-05 **Full Scale:** 200 G
Serial #: 427 **Op. Number:** 740 **Calibration Date:** 05/04/05

Room Temperature Correction Factors:

Y = G's measured X = Output In Volts

Linear Fit:

$$Y = aX + b$$

	X-Axis	Y-Axis	Z-Axis
b	-4.292E-01	3.593E-01	5.426E-01
a	4.004E+01	4.011E+01	3.973E+01
RMS Error	3.288E-01	3.319E-01	3.121E-01

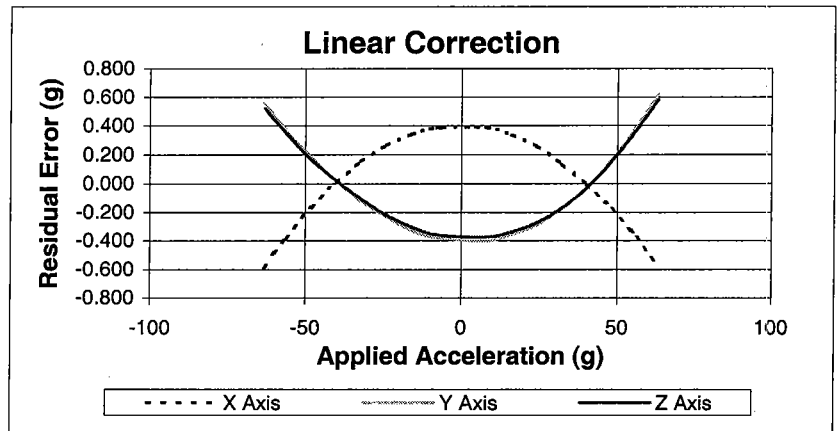

2nd order Fit:

$$Y = a_2 X^2 + a_1 X + b$$

	X-Axis	Y-Axis	Z-Axis
b	-8.298E-01	7.634E-01	9.225E-01
a₁	4.004E+01	4.011E+01	3.973E+01
a₂	3.944E-01	-3.999E-01	-3.687E-01
RMS Error	3.677E-03	1.606E-02	1.658E-02

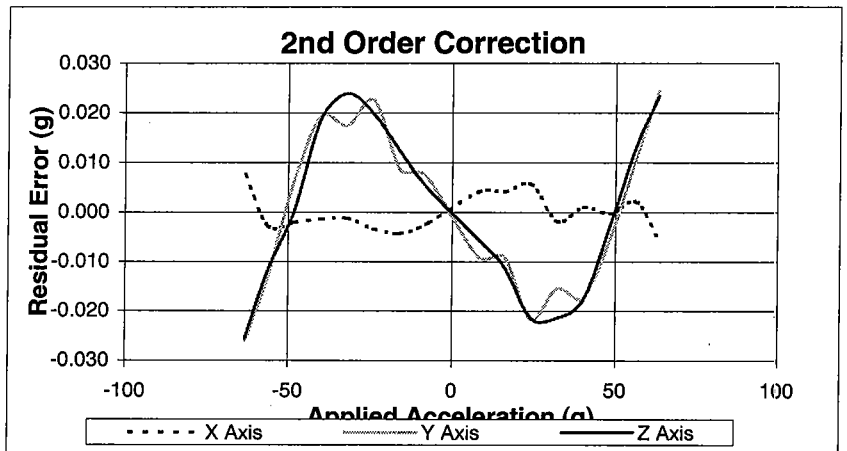

3rd order Fit:

$$Y = a_3 X^3 + a_2 X^2 + a_1 X + b$$

	X-Axis	Y-Axis	Z-Axis
b	-8.298E-01	7.633E-01	9.226E-01
a₁	4.003E+01	4.015E+01	3.976E+01
a₂	3.944E-01	-3.996E-01	-3.688E-01
a₃	3.746E-03	-2.203E-02	-2.206E-02
RMS Error	2.491E-03	3.204E-03	3.456E-03

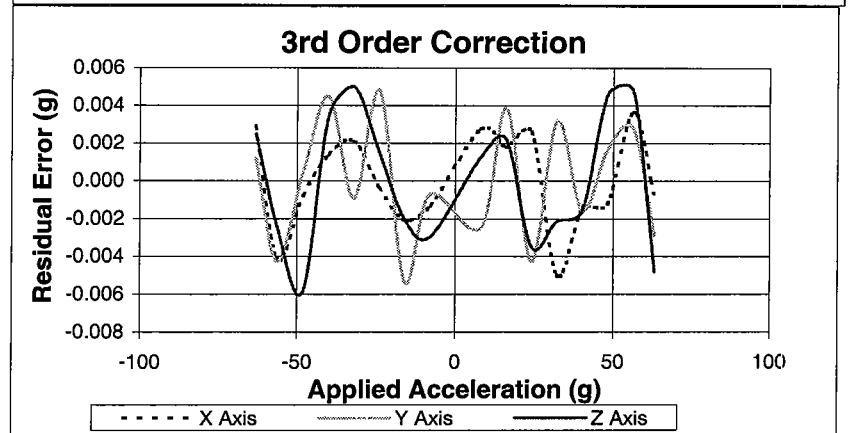



Model: 2430-200

CALIBRATION CERTIFICATE

Part #: 153-00007-05 Doc. Rev. D

Mfg. Lot #: 0m063a

Op. Number: 740

	X-Axis	Y-Axis	Z-Axis	
+1 G DC:	51.0	-14.0	14.0	mV DC
-1 G DC:	2.0	-63.0	-36.0	mV DC
0 G Bias	26.0	-39.0	-11.0	mV DC
Scale Factor	24.50	24.50	24.80	mV/G
Sensor ID	71916	71877	71896	

Operator: Jerry

Serial #: 486

Calibration Date: 05/04/05

Supply Current: 26.5 mA

Full Scale: 200 G

Calibration Freq. 100 Hz

Linearity Error

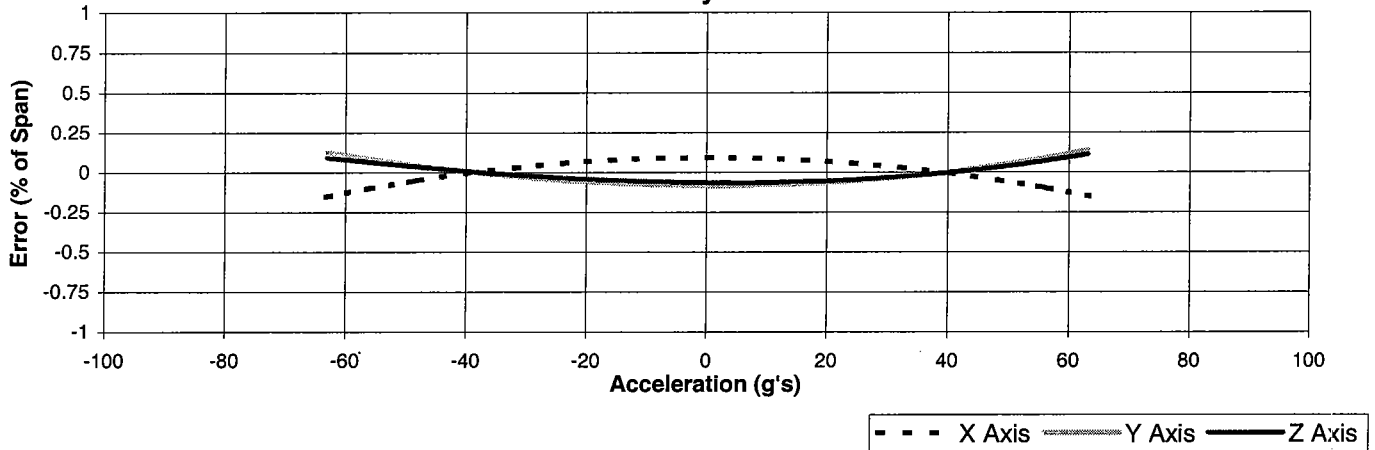

Frequency Response*

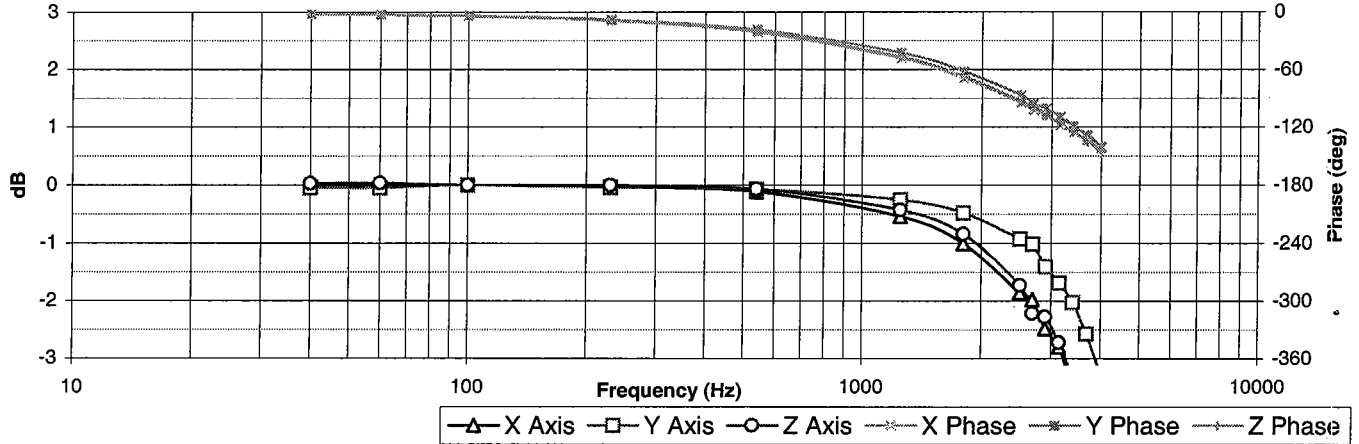

Freq. (Hz)**	40	60	100	230	540	1250	1800	2500	2690	2900	3140	3400	3685	4000
dB Out - X	-0.03	-0.03	0.00	-0.04	-0.11	-0.54	-1.01	-1.85	-1.97	-2.48	-2.79	-3.47	-4.08	-4.58
Phase (deg)	-2.3	-2.9	-4.5	-9.3	-21.3	-48.5	-69.3	-94.5	-102.2	-107.5	-117.5	-125.4	-133.8	-142.5
Freq. (Hz)**	40	60	100	230	540	1250	1800	2500	2690	2900	3140	3400	3685	4000
dB Out - Y	-0.05	-0.04	0.00	-0.04	-0.07	-0.25	-0.48	-0.92	-1.01	-1.40	-1.69	-2.02	-2.57	-3.25
Phase (deg)	-2.1	-2.7	-4.1	-8.1	-18.6	-42.5	-62.0	-86.7	-96.0	-100.6	-109.4	-119.0	-128.5	-140.1
Freq. (Hz)**	40	60	100	230	540	1250	1800	2500	2690	2900	3140	3400	3685	4000
dB Out - Z	0.03	0.03	0.00	-0.01	-0.06	-0.42	-0.84	-1.73	-2.21	-2.27	-2.72	-3.30	-3.85	-4.70
Phase (deg)	-2.2	-2.8	-4.2	-8.9	-20.4	-46.9	-67.3	-92.7	-97.5	-107.7	-115.9	-124.7	-134.7	-145.7

* Reference Frequency is 100 Hz

** 14.142 g Peak Acceleration Traceable to NIST through Vibration Calibration Standard M-90157

Final Status:

Pass:



CALIBRATION CERTIFICATE PAGE 2

Model: 2430-200 **Part #:** 153-00007-05 **Full Scale:** 200 G
Serial #: 486 **Op. Number:** 740 **Calibration Date:** 05/04/05

Room Temperature Correction Factors:

Y = G's measured X = Output In Volts

Linear Fit:

Y = aX + b

	X-Axis	Y-Axis	Z-Axis
b	-1.094E+00	1.677E+00	4.792E-01
a	4.078E+01	4.079E+01	4.024E+01
RMS Error	3.350E-01	2.948E-01	2.273E-01

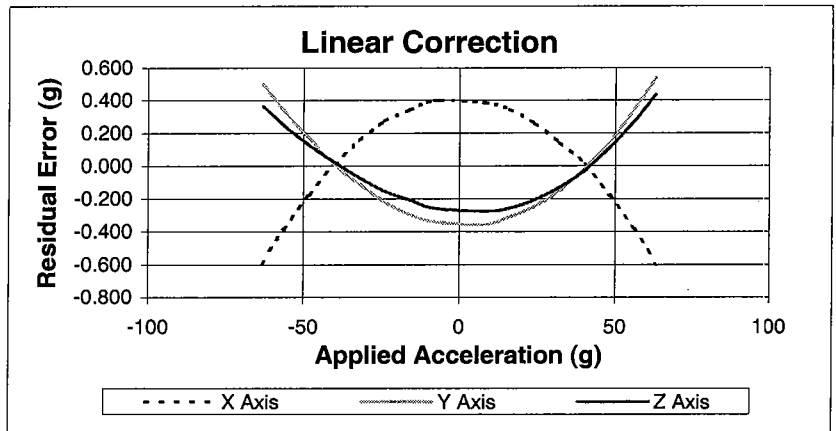

2nd order Fit:

Y = a₂ X² + a₁ X + b

	X-Axis	Y-Axis	Z-Axis
b	-1.503E+00	2.035E+00	7.549E-01
a₁	4.077E+01	4.077E+01	4.024E+01
a₂	4.174E-01	-3.684E-01	-2.750E-01
RMS Error	4.895E-03	9.119E-03	2.111E-02

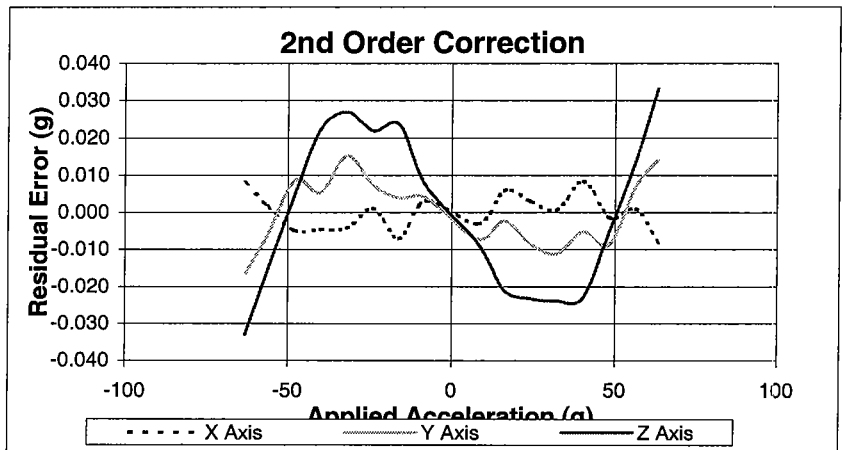

3rd order Fit:

Y = a₃ X³ + a₂ X² + a₁ X + b

	X-Axis	Y-Axis	Z-Axis
b	-1.502E+00	2.036E+00	7.551E-01
a₁	4.076E+01	4.079E+01	4.029E+01
a₂	4.172E-01	-3.695E-01	-2.753E-01
a₃	5.374E-03	-1.261E-02	-2.958E-02
RMS Error	3.246E-03	3.215E-03	2.981E-03

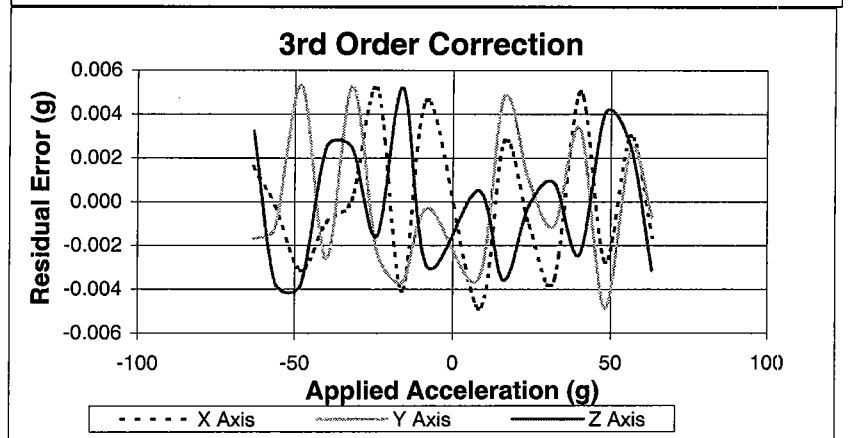



Model: 2430-100

CALIBRATION CERTIFICATE

Part #: 153-00007-04 Doc. Rev. D

Mfg. Lot #: 4m286a

Op. Number: 740

	X-Axis	Y-Axis	Z-Axis	
+1 G DC:	60.0	28.0	34.0	mV DC
-1 G DC:	-37.0	-71.0	-65.0	mV DC
0 G Bias	11.0	-22.0	-15.0	mV DC
Scale Factor	49.00	48.80	49.50	mV/G
Sensor ID	168393	168419	168381	

Operator: joe

Serial #: 677

Calibration Date: 10/27/04

Supply Current: 27.1 mA

Full Scale: 100 G

Calibration Freq. 100 Hz

Linearity Error

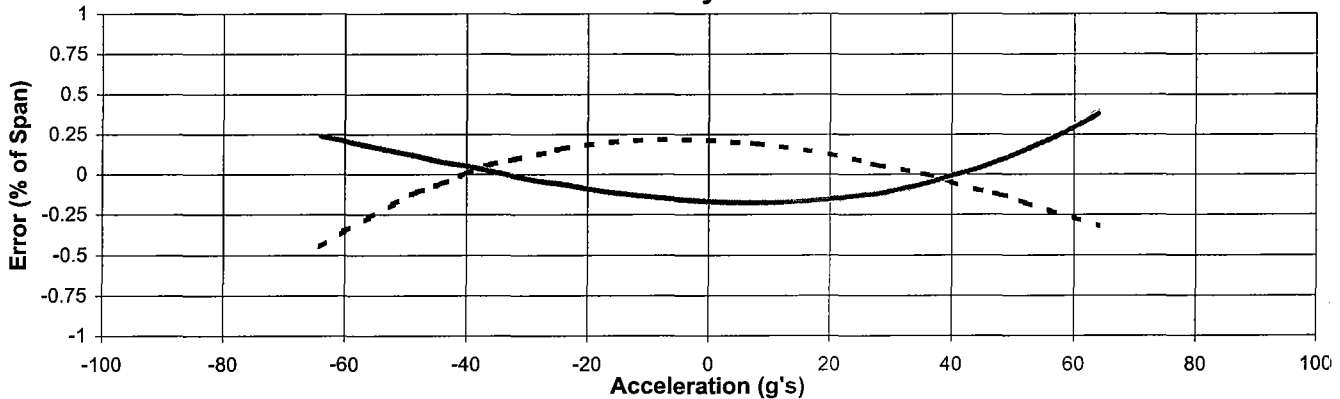

- - - X Axis Y Axis ——— Z Axis

Frequency Response*

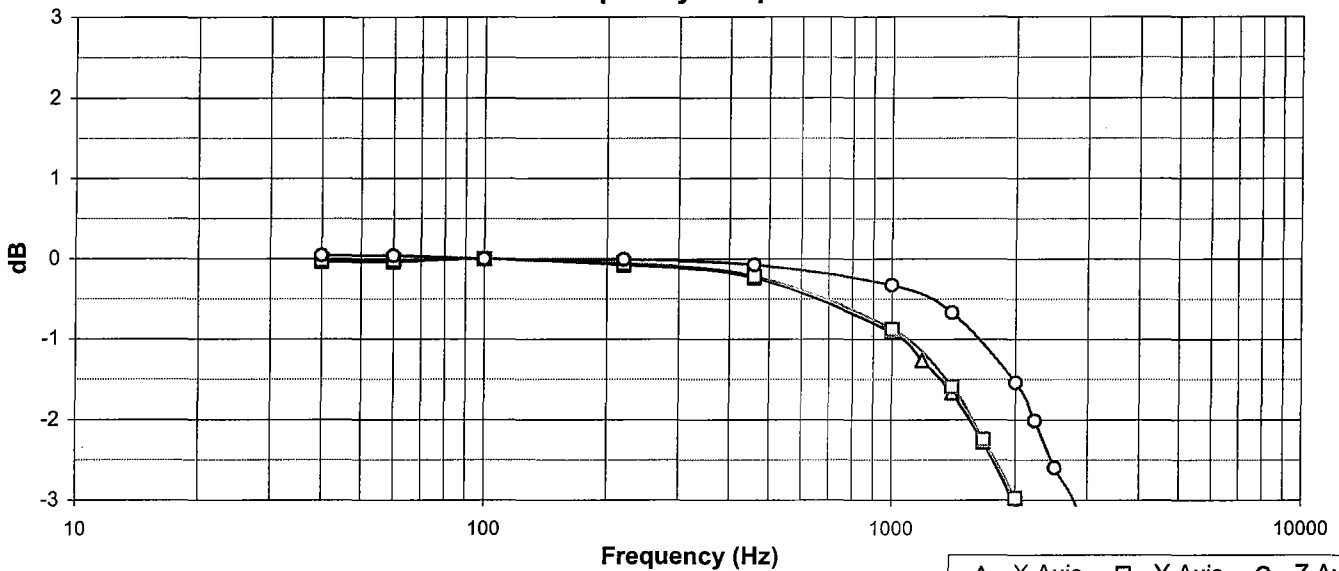

—△— X Axis —□— Y Axis —○— Z Axis

Freq. (Hz)**	40	60	100	220	460	1000	1185	1400	1675	2000	2235	2500	3200	4000
dB Out - X	-0.033	-0.037	0	-0.076	-0.234	-0.913	-1.263	-1.668	-2.28	-3.065	-3.663	-4.307	-6.239	-8.599
dB Out - Y	-0.019	-0.018	0	-0.062	-0.22	-0.873	-1.592	-2.24	-2.974	-3.721	-4.435	-5.481	-6.422	-8.841
dB Out - Z	0.041	0.039	0	-0.009	-0.076	-0.332	-0.671	-1.542	-2.015	-2.6	-3.106	-4.287	-5.304	-6.656

* Reference Frequency is 100 Hz

** 14.142 g Peak Acceleration Traceable to NIST through Vibration Calibration Standard M-90157

Final Status:

Pass:



CALIBRATION CERTIFICATE PAGE 2

Model: 2430-100 **Part #:** 153-00007-04 **Full Scale:** 100 G
Serial #: 677 **Op. Number:** 740 **Calibration Date:** 10/27/04

Room Temperature Correction Factors:

Y = G's measured X = Output In Volts

Linear Fit:

$$Y = aX + b$$

	X-Axis	Y-Axis	Z-Axis
b	-3.957E-01	4.729E-01	3.922E-01
a	2.042E+01	2.049E+01	2.020E+01
RMS Error	3.879E-01	3.262E-01	3.099E-01

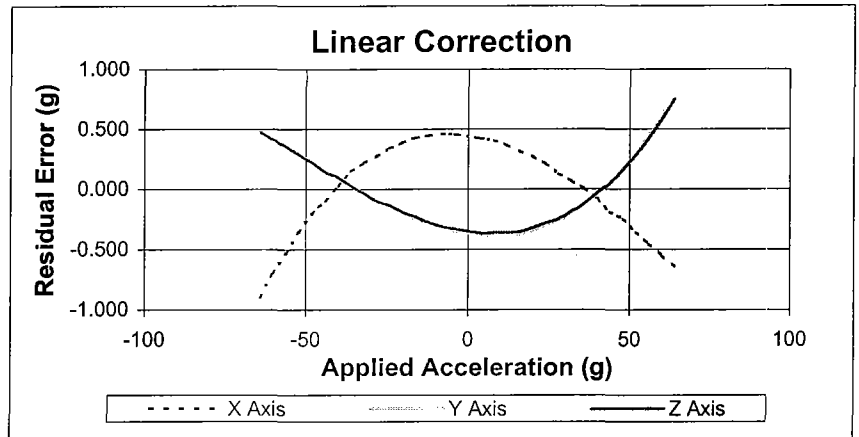

2nd order Fit:

$$Y = a_2 X^2 + a_1 X + b$$

	X-Axis	Y-Axis	Z-Axis
b	-8.401E-01	8.417E-01	7.437E-01
a₁	2.042E+01	2.049E+01	2.020E+01
a₂	1.237E-01	-1.035E-01	-9.580E-02
RMS Error	5.376E-02	6.824E-02	5.959E-02

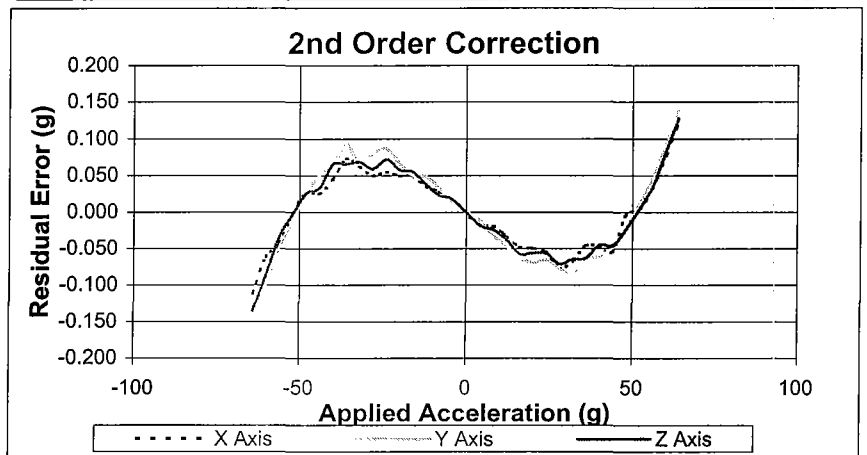

3rd order Fit:

$$Y = a_3 X^3 + a_2 X^2 + a_1 X + b$$

	X-Axis	Y-Axis	Z-Axis
b	-8.396E-01	8.418E-01	7.436E-01
a₁	2.049E+01	2.057E+01	2.027E+01
a₂	1.233E-01	-1.033E-01	-9.560E-02
a₃	-1.025E-02	-1.328E-02	-1.108E-02
RMS Error	8.126E-03	6.561E-03	5.613E-03

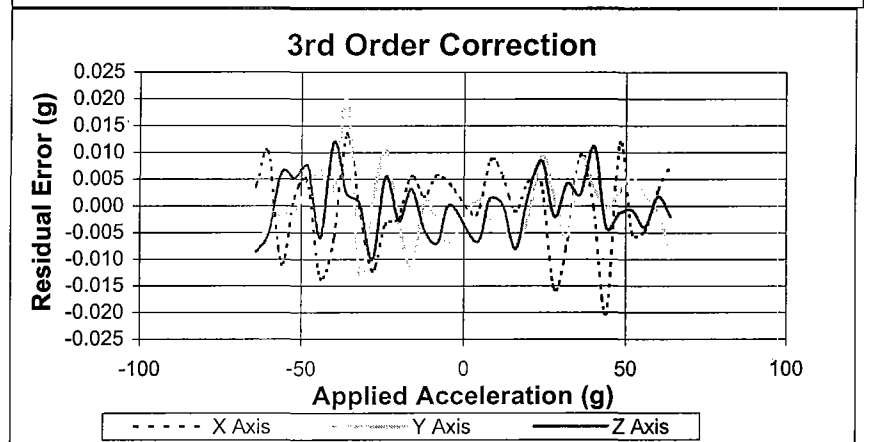



Model: **2430-100**

CALIBRATION CERTIFICATE

Part #: **153-00007-04** Doc. Rev. **D**

Mfg. Lot #: **4m286a**

Op. Number: **740**

	X-Axis	Y-Axis	Z-Axis	
+1 G DC:	28.0	50.0	38.0	mV DC
-1 G DC:	-70.0	-49.0	-61.0	mV DC
0 G Bias	-21.0	0.0	-12.0	mV DC
Scale Factor	49.30	49.10	49.80	mV/G
Sensor ID	168386	168379	168394	

Operator: **joe**

Serial #: **678**

Calibration Date: **10/27/04**

Supply Current: **27.2 mA**

Full Scale: **100 G**

Calibration Freq. **100 Hz**

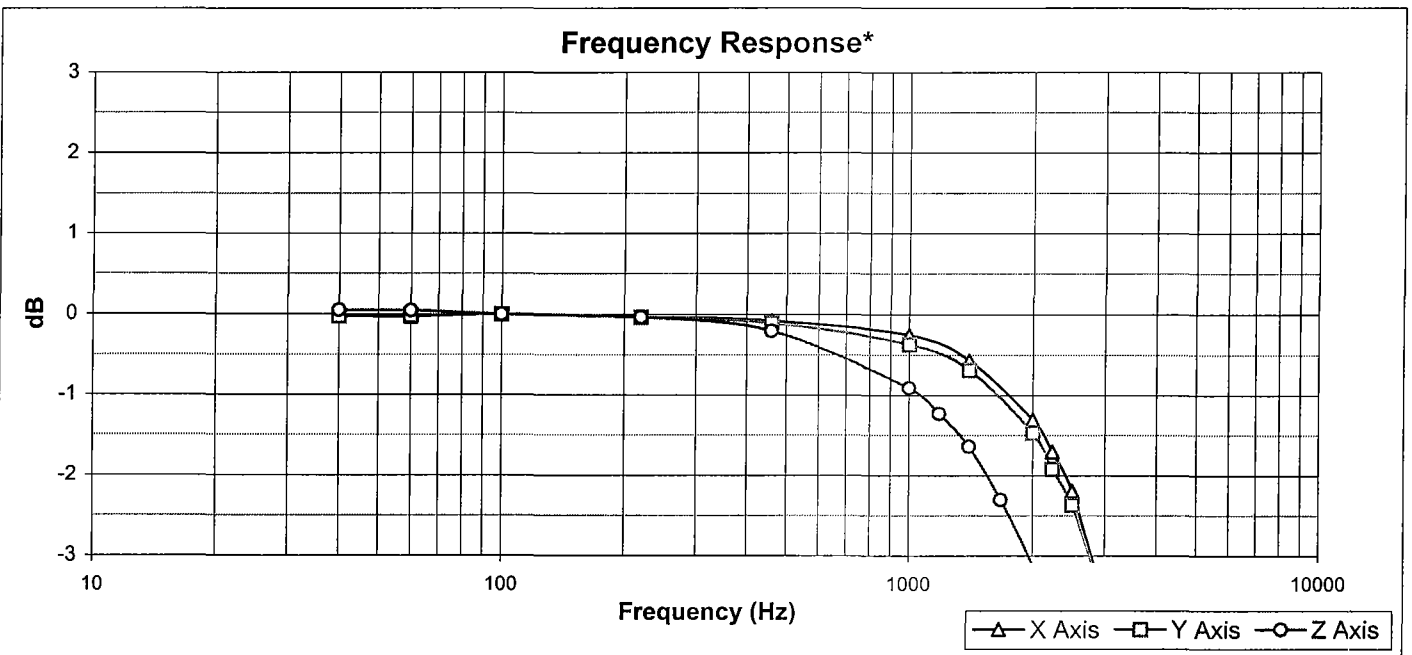
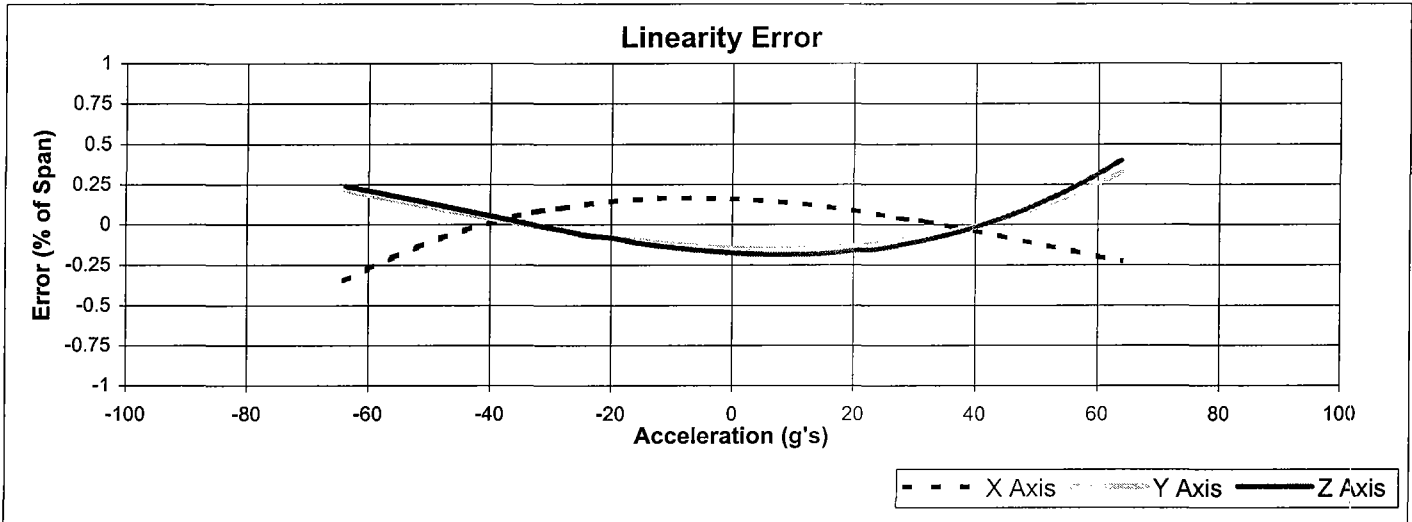

Freq. (Hz)**	40	60	100	220	460	1000	1400	2000	2235	2500	2830	3200	3575	4000
dB Out - X	-0.026	-0.029	0	-0.037	-0.081	-0.256	-0.569	-1.305	-1.701	-2.191	-3.118	-3.941	-5.058	-6.043
dB Out - Y	-0.025	-0.023	0	-0.036	-0.107	-0.37	-0.686	-1.465	-1.918	-2.367	-3.157	-3.777	-4.749	-5.922
dB Out - Z	0.047	0.043	0	-0.036	-0.209	-0.908	-1.228	-1.638	-2.303	-3.107	-3.757	-4.5	-6.27	-8.522

* Reference Frequency is 100 Hz

** 14.142 g Peak Acceleration Traceable to NIST through Vibration Calibration Standard M-90157

Final Status:

Pass:



CALIBRATION CERTIFICATE PAGE 2

Model: 2430-100 **Part #:** 153-00007-04 **Full Scale:** 100 G
Serial #: 678 **Op. Number:** 740 **Calibration Date:** 10/27/04

Room Temperature Correction Factors:

Y = G's measured X = Output In Volts

Linear Fit:

$$Y = aX + b$$

	X-Axis	Y-Axis	Z-Axis
b	2.794E-01	1.073E-01	3.344E-01
a	2.026E+01	2.038E+01	2.009E+01
RMS Error	2.914E-01	2.723E-01	3.237E-01

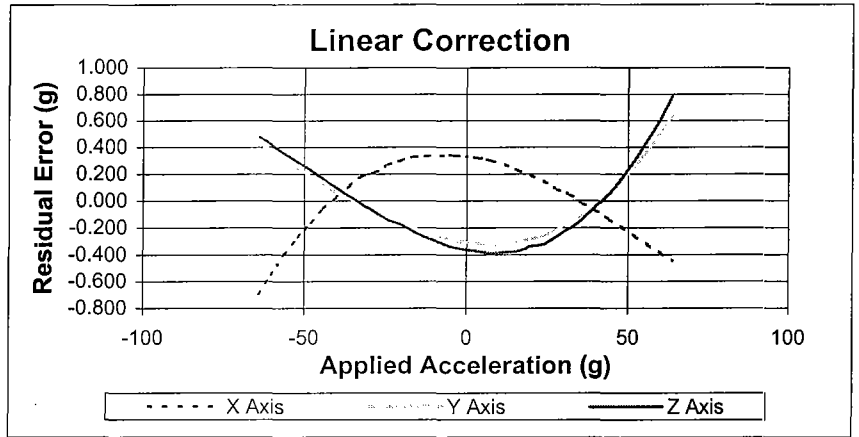

2nd order Fit:

$$Y = a_2 X^2 + a_1 X + b$$

	X-Axis	Y-Axis	Z-Axis
b	-5.187E-02	4.176E-01	7.000E-01
a₁	2.027E+01	2.039E+01	2.009E+01
a₂	9.077E-02	-8.609E-02	-9.859E-02
RMS Error	5.347E-02	4.879E-02	6.990E-02

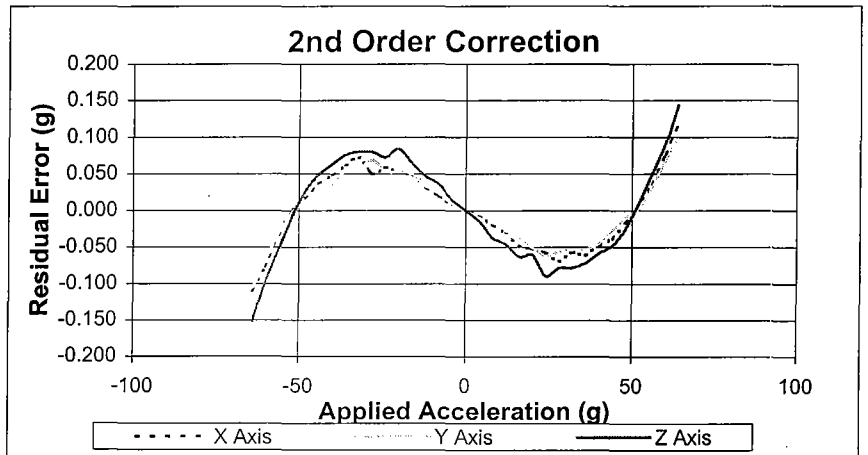

3rd order Fit:

$$Y = a_3 X^3 + a_2 X^2 + a_1 X + b$$

	X-Axis	Y-Axis	Z-Axis
b	-4.972E-02	4.168E-01	6.996E-01
a₁	2.033E+01	2.045E+01	2.018E+01
a₂	8.964E-02	-8.563E-02	-9.822E-02
a₃	-1.004E-02	-9.369E-03	-1.285E-02
RMS Error	4.684E-03	4.446E-03	5.206E-03

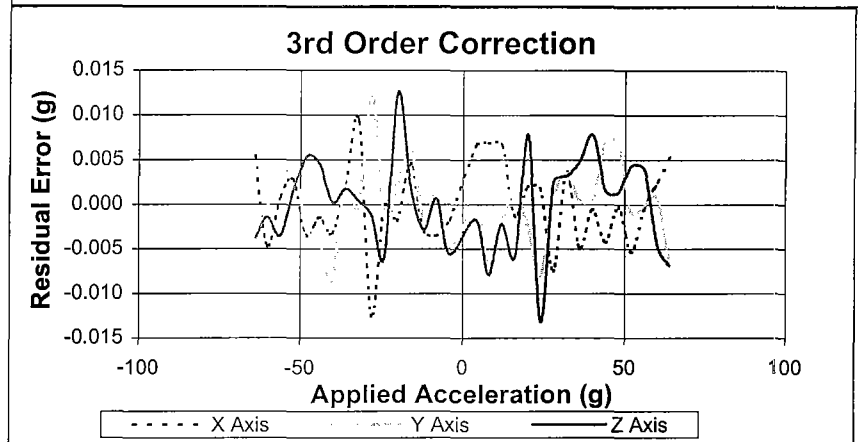



CALIBRATION CERTIFICATE

Mfg Lot #: 5m031a Model: 2210-200 Part #: 153-00001-05 Doc. Rev. D
 Serial #: 7132 Operator: ch +1 G DC: 33 mV DC
 Calibration Date: 02/28/05 -1 G DC: -6 mV DC
 Full Scale: 200 g Calibration Freq.: 100 Hz 0 G Bias: 14 mV DC
 Sensor ID: 133344 Scale Factor: 19.7 mV/G
 Supply Current: 7.9 mA Op. Number: 135

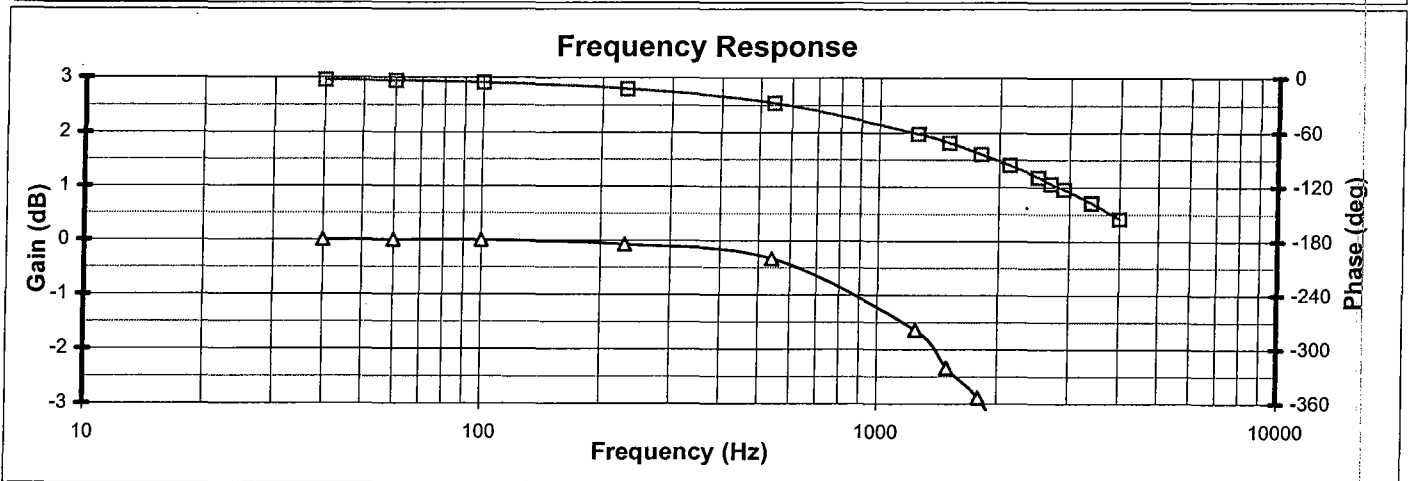
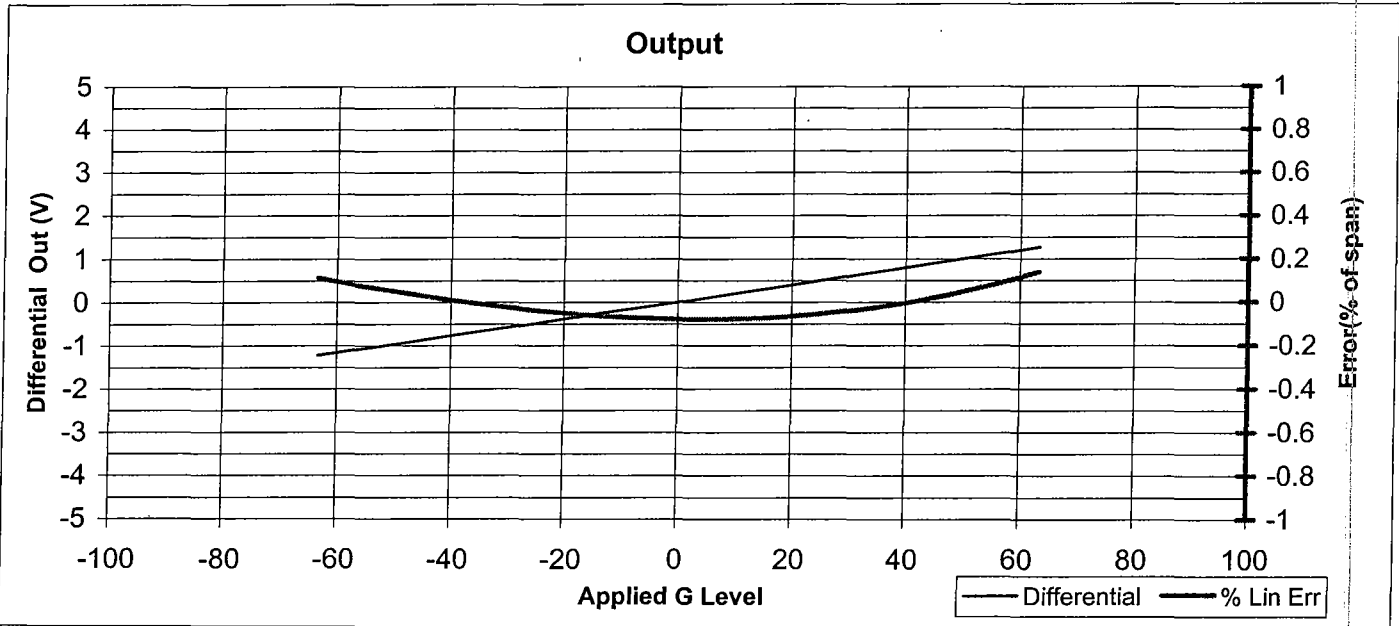

Freq. (Hz)**	40	60	100	230	540	1250	1500	1800	2120	2500	2690	2900	3400	4000
dB Out	0.01	0.00	0.00	-0.08	-0.34	-1.64	-2.34	-2.89	-3.75	-4.77	-5.12	-6.16	-7.53	-9.33
SF mV/g	20	20	20	19	19	16	15	14	13	11	11	10	8	7
Phase (deg)	-3	-4	-6	-12	-28	-61	-71	-83	-95	-109	-116	-122	-137	-155

* Reference Frequency is 100 Hz

** 14.142 g Peak Acceleration Traceable to NIST through Vibration Calibration Standard M-90157

Final Status:

Pass:



CALIBRATION CERTIFICATE PAGE 2

Model: 2210-200 Part #: 153-00001-05 Full Scale: 200 G

Serial #: 7132 Op. Number: 135 Calibration Date: 02/28/05

Room Temperature Correction Factors:

Y = G's measured X = Output In Volts

Linear Fit:

$$Y = aX + b$$

b -6.050E-01
a 5.078E+01

RMS Error 2.603E-01

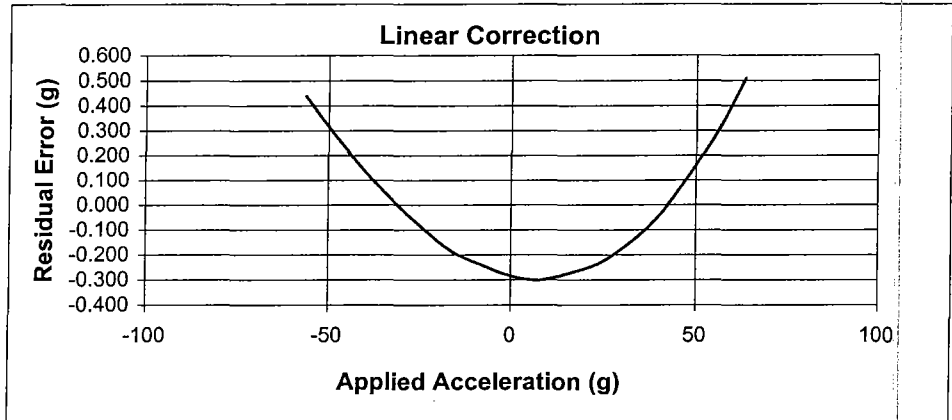

2nd order Fit:

$$Y = a_2 X^2 + a_1 X + b$$

b -3.178E-01
a₁ 5.089E+01
a₂ -5.531E-01

RMS Error 2.253E-02

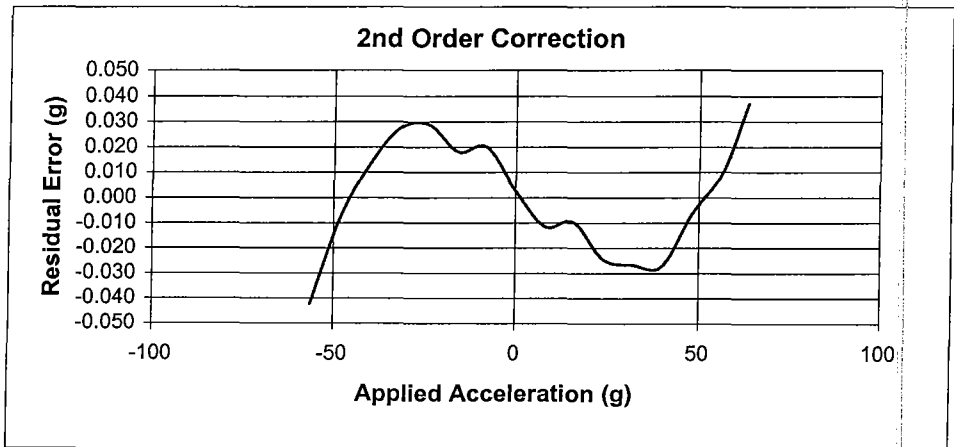

3rd order Fit:

$$Y = a_3 X^3 + a_2 X^2 + a_1 X + b$$

b -3.241E-01
a₁ 5.096E+01
a₂ -5.321E-01
a₃ -7.606E-02

RMS Error 3.572E-03

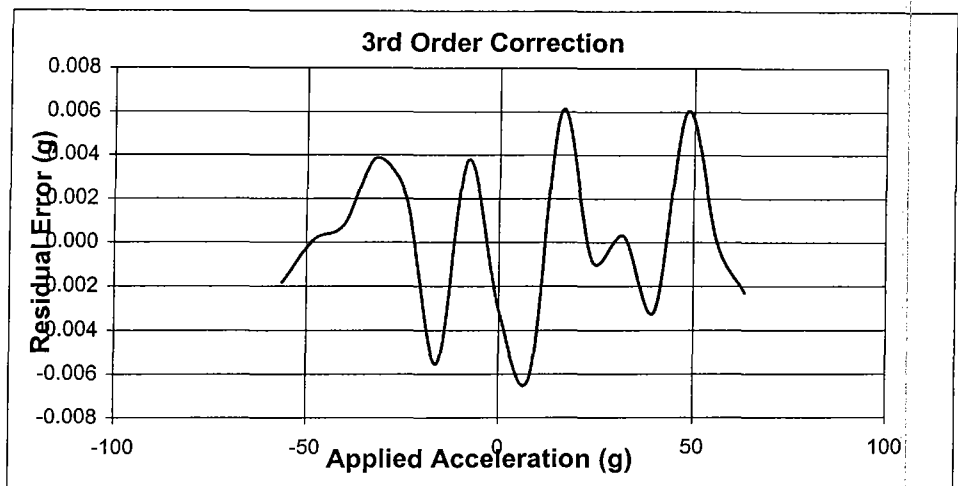



CALIBRATION CERTIFICATE

Mfg Lot #: <u>5m031a</u>	Model: <u>2210-200</u>	Part #: <u>153-00001-05</u>	Doc. Rev. <u>D</u>
			Op. Number: <u>135</u>
Serial #: <u>7133</u>	Operator: <u>ch</u>	+1 G DC: <u>-4 mV DC</u>	
	Calibration Date: <u>02/28/05</u>	-1 G DC: <u>-45 mV DC</u>	
Full Scale: <u>200 g</u>	Calibration Freq.: <u>100 Hz</u>	0 G Bias: <u>-25 mV DC</u>	
	Sensor ID: <u>127946</u>	Scale Factor: <u>19.7 mV/G</u>	
		Supply Current: <u>7.0 mA</u>	

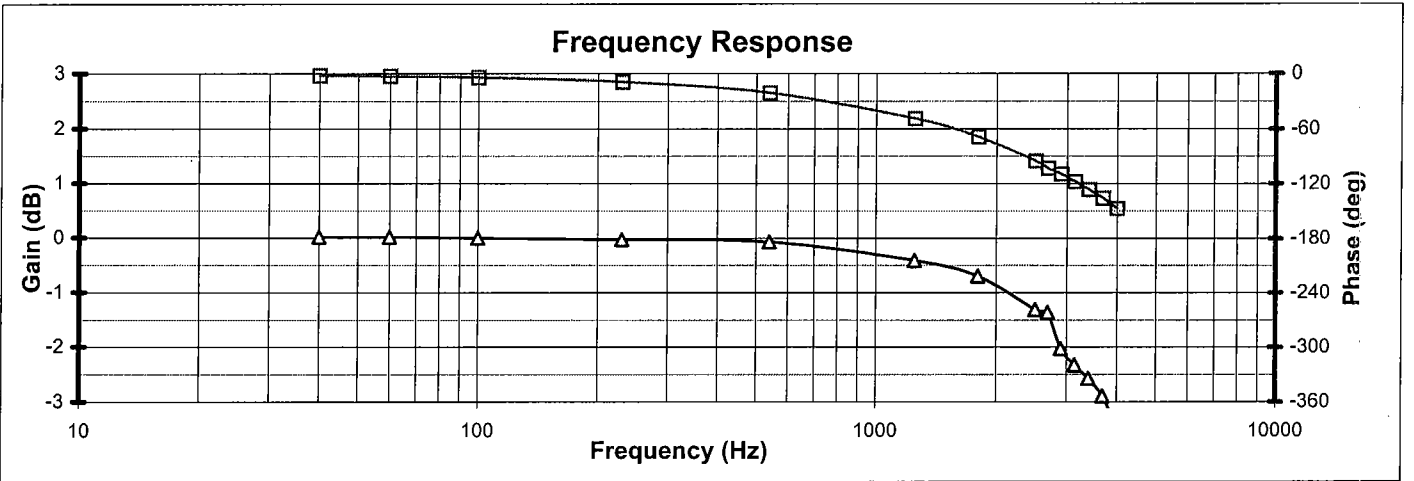
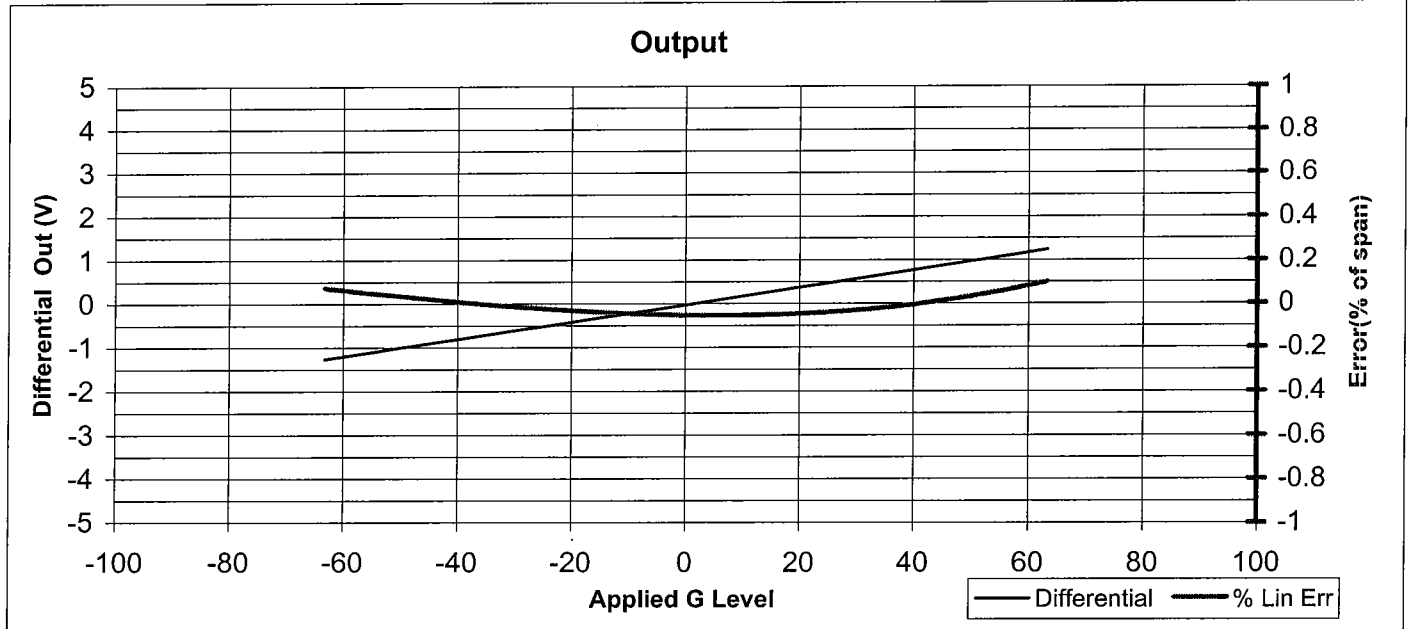

Freq. (Hz)**	40	60	100	230	540	1250	1800	2500	2690	2900	3140	3400	3685	4000
dB Out	0.02	0.02	0.00	-0.03	-0.07	-0.42	-0.70	-1.31	-1.36	-2.03	-2.33	-2.57	-2.90	-3.44
SF mV/g	20	20	20	20	19	19	18	17	17	16	15	15	14	13
Phase (deg)	-2	-3	-4	-9	-21	-49	-69	-95	-103	-109	-118	-126	-136	-147

* Reference Frequency is 100 Hz
 ** 14.142 g Peak Acceleration Traceable to NIST through Vibration Calibration Standard M-90157

Final Status:
Pass:

website: www.silicondesigns.com e-mail: sales@silicondesigns.com



CALIBRATION CERTIFICATE PAGE 2

Model: 2210-200 Part #: 153-00001-05 Full Scale: 200 G

Serial #: 7133 Op. Number: 135 Calibration Date: 02/28/05

Room Temperature Correction Factors:

Y = G's measured X = Output In Volts

Linear Fit:

$Y = aX + b$

b 1.298E+00
a 5.073E+01

RMS Error 1.812E-01

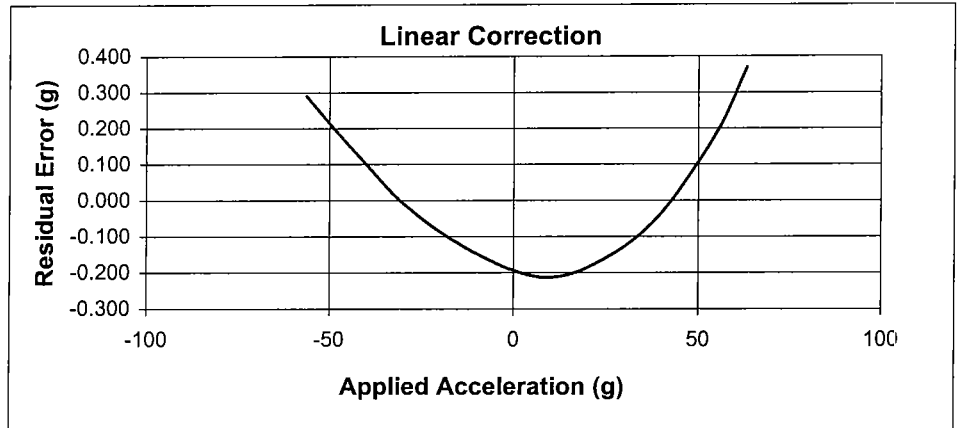

2nd order Fit:

$Y = a_2 X^2 + a_1 X + b$

b 1.500E+00
a₁ 5.078E+01
a₂ -3.826E-01

RMS Error 2.403E-02

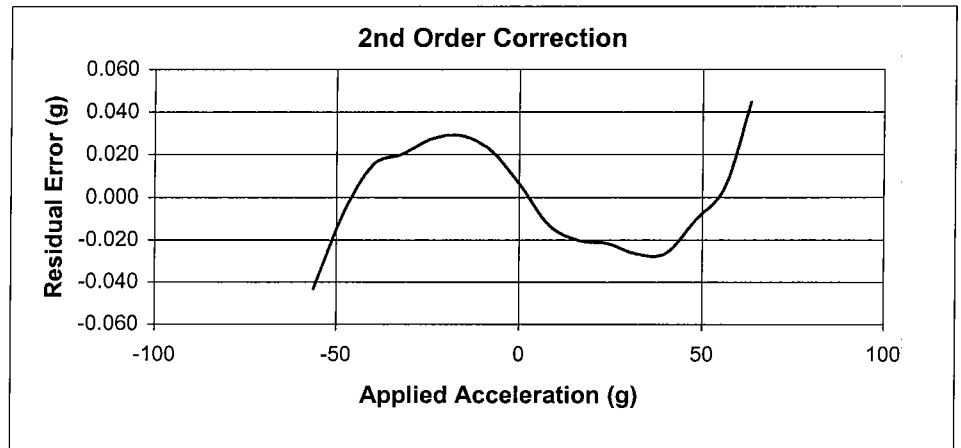

3rd order Fit:

$Y = a_3 X^3 + a_2 X^2 + a_1 X + b$

b 1.496E+00
a₁ 5.085E+01
a₂ -3.700E-01
a₃ -8.126E-02

RMS Error 3.427E-03

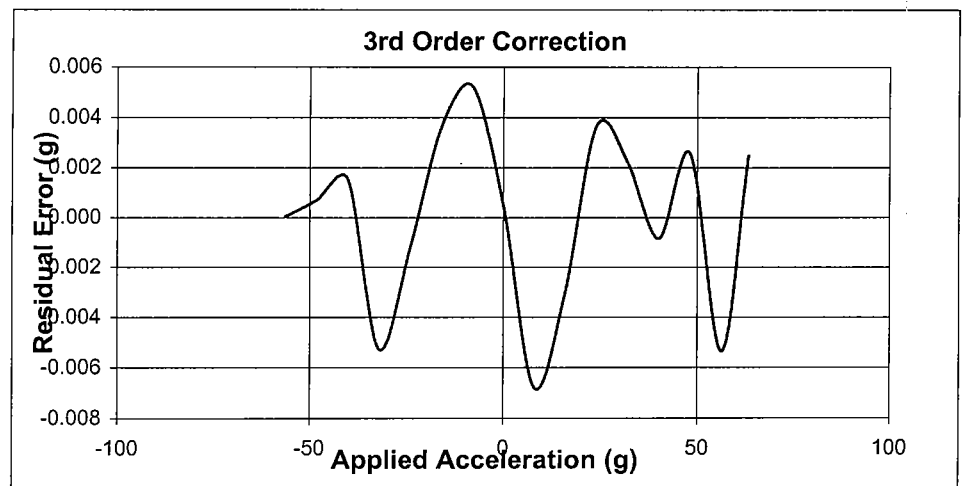



CALIBRATION CERTIFICATE

Mfg Lot #: 5m031a Model: 2210-200 Part #: 153-00001-05 Doc. Rev. D
 Serial #: 7134 Operator: ch Op. Number: 135
 Full Scale: 200 g Calibration Date: 02/28/05 +1 G DC: 14 mV DC
 Calibration Freq.: 100 Hz -1 G DC: -25 mV DC
 Sensor ID: 127944 0 G Bias: -6 mV DC
 Scale Factor: 19.7 mV/G
 Supply Current: 7.6 mA

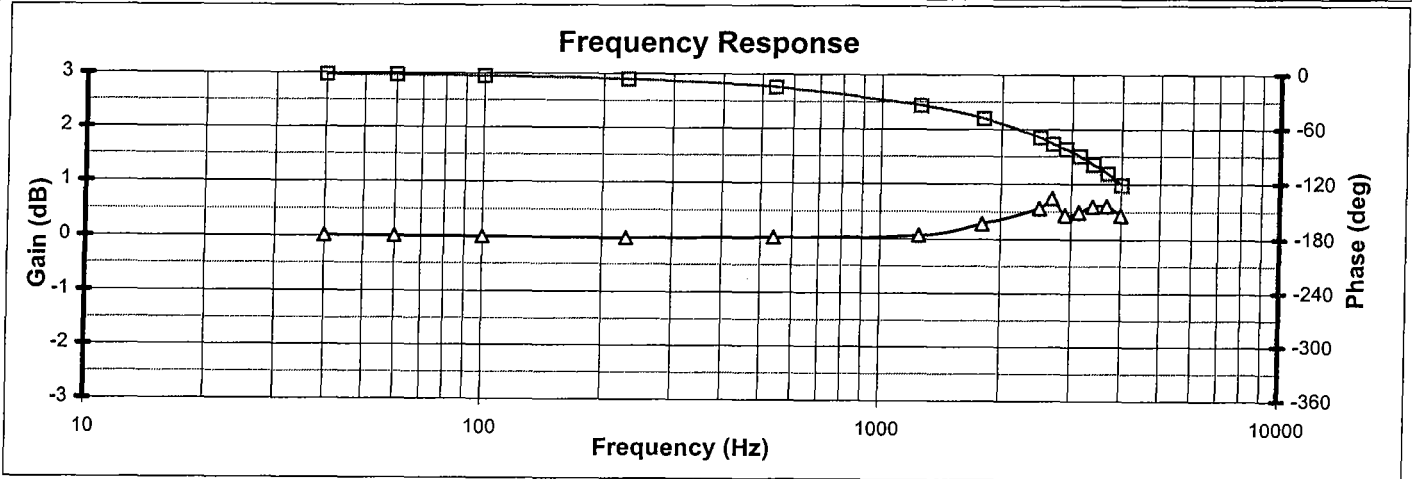
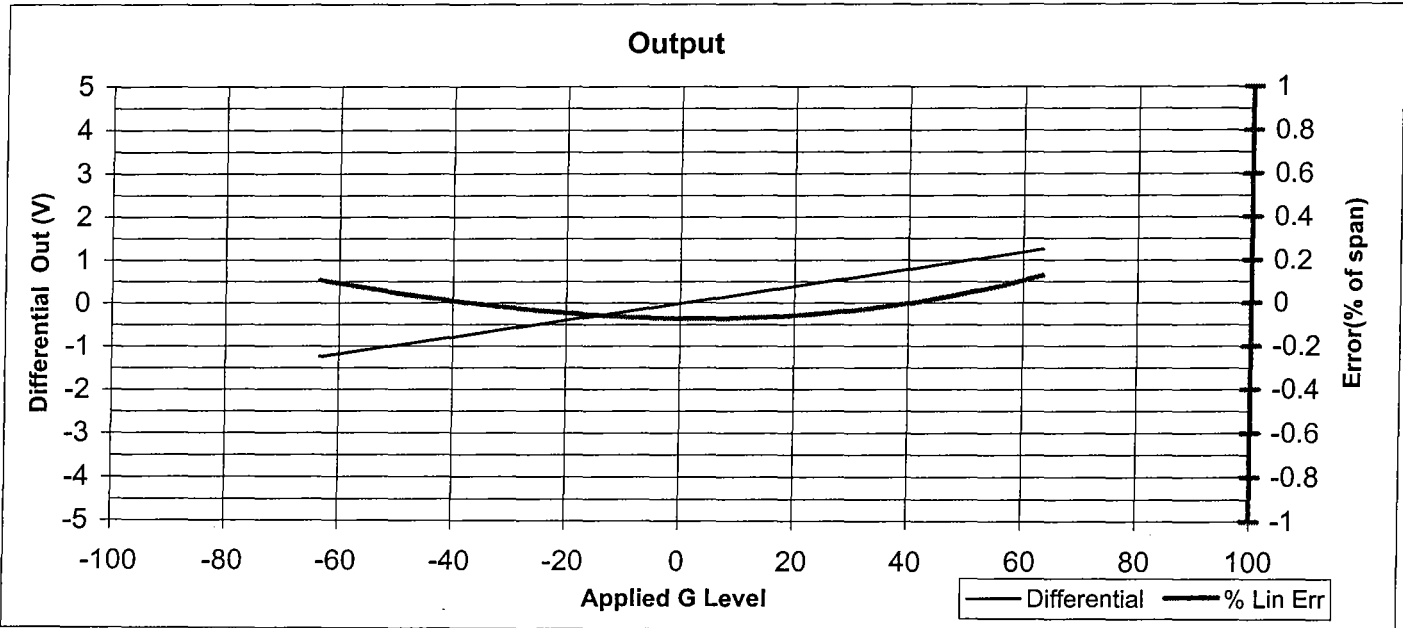

Freq. (Hz)**	40	60	100	230	540	1250	1800	2500	2690	2900	3140	3400	3685	4000
dB Out	0.01	0.01	0.00	-0.02	0.01	0.07	0.28	0.56	0.74	0.44	0.49	0.59	0.60	0.43
SF mV/g	20	20	20	20	20	20	20	21	21	21	21	21	21	21
Phase (deg)	-2	-2	-3	-6	-14	-34	-48	-69	-76	-82	-90	-98	-108	-121

* Reference Frequency is 100 Hz

** 14.142 g Peak Acceleration Traceable to NIST through Vibration Calibration Standard M-90157

Final Status:

Pass:

website: www.silicondesigns.com

e-mail: sales@silicondesigns.com



CALIBRATION CERTIFICATE PAGE 2

Model: 2210-200 Part #: 153-00001-05 Full Scale: 200 G

Serial #: 7134 Op. Number: 135 Calibration Date: 02/28/05

Room Temperature Correction Factors:

Y = G's measured X = Output In Volts

Linear Fit:

$$Y = aX + b$$

b 3.182E-01
a 5.070E+01

RMS Error 2.389E-01

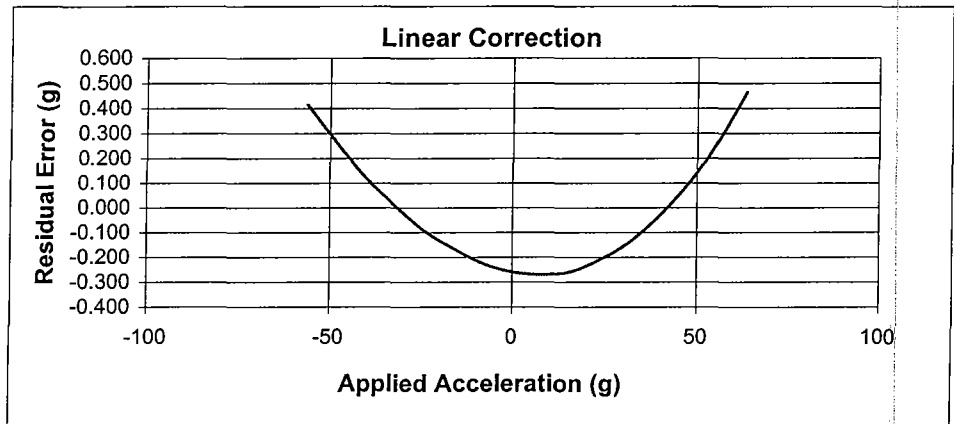

2nd order Fit:

$$Y = a_2 X^2 + a_1 X + b$$

b 5.832E-01
a₁ 5.078E+01
a₂ -5.062E-01

RMS Error 1.691E-02

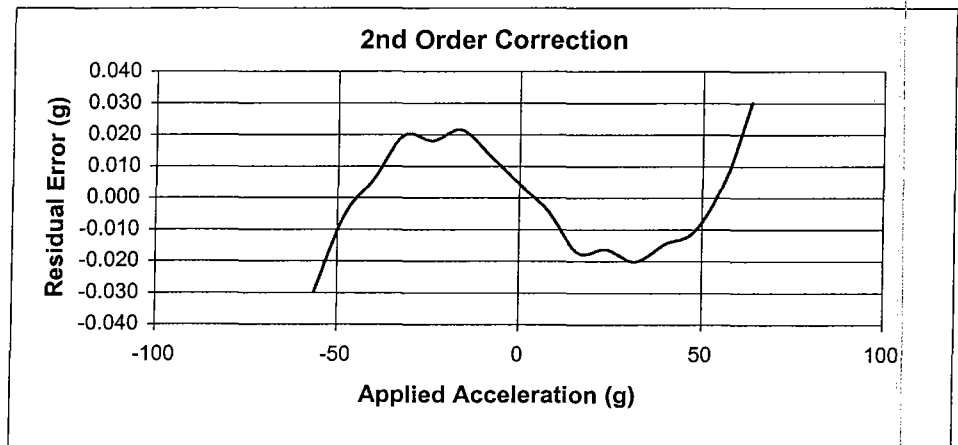

3rd order Fit:

$$Y = a_3 X^3 + a_2 X^2 + a_1 X + b$$

b 5.794E-01
a₁ 5.083E+01
a₂ -4.935E-01
a₃ -5.681E-02

RMS Error 2.294E-03

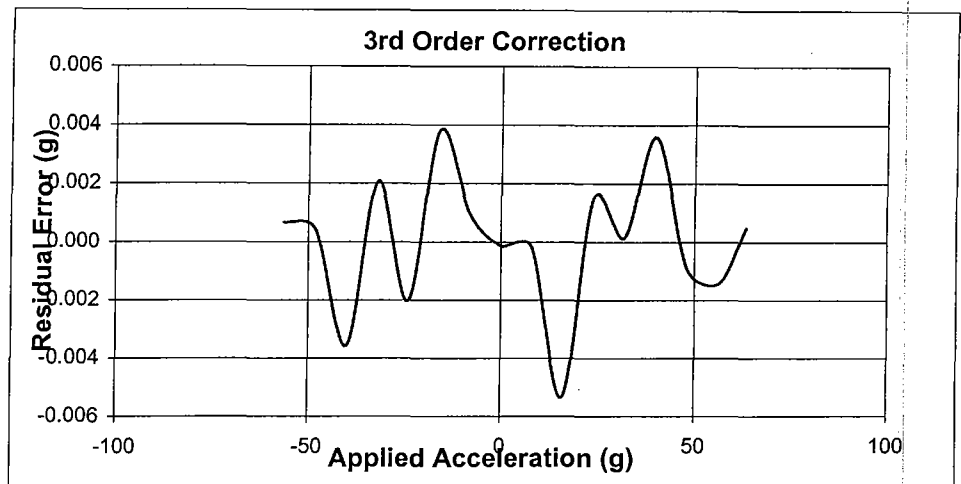



SILICON DESIGNS INC. 1445 NW Mall St., Issaquah WA 98027-5344, (425) 391-8329, FAX (425) 391-0446

Model: 2440-025

CALIBRATION CERTIFICATE

Part #: 153-00024-02 Doc. Rev. -

Mfg. Lot #: 4m242a

Op. Number: 740

	X-Axis	Y-Axis	Z-Axis	
+1 G DC:	204.0	179.0	219.0	mV DC
-1 G DC:	-193.0	-217.0	-180.0	mV DC
0 G Bias	6.0	-19.0	19.0	mV DC
Scale Factor	197.10	197.10	199.00	mV/G
Sensor ID	165246	166770	166788	

Serial #: 26

Operator: lynn

Calibration Date: 09/13/04

Supply Current: 27.2 mA

Calibration Freq. 50 Hz

Full Scale: 25 G

Linearity Error

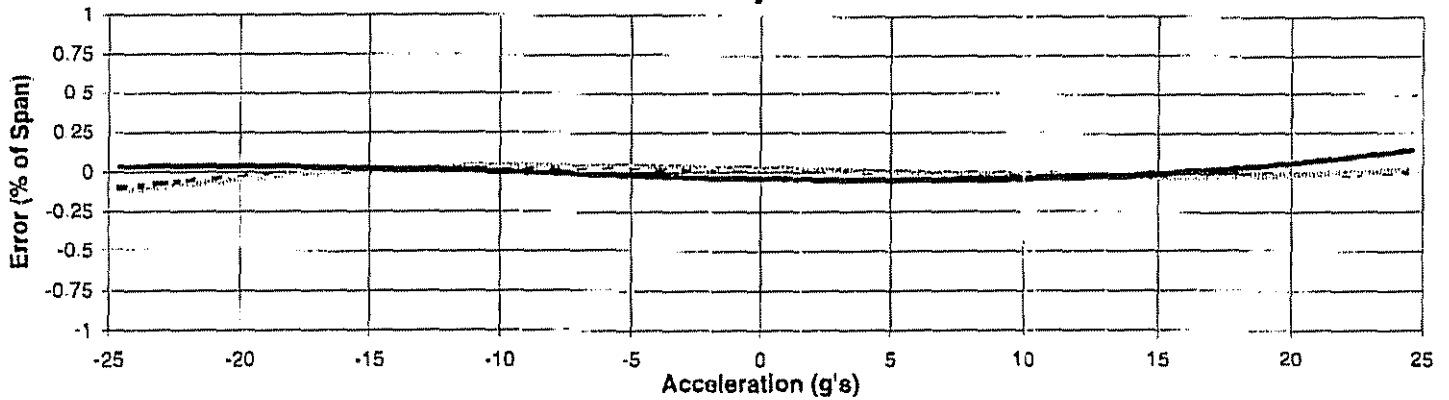

--- X Axis --- Y Axis — Z Axis

Frequency Response*

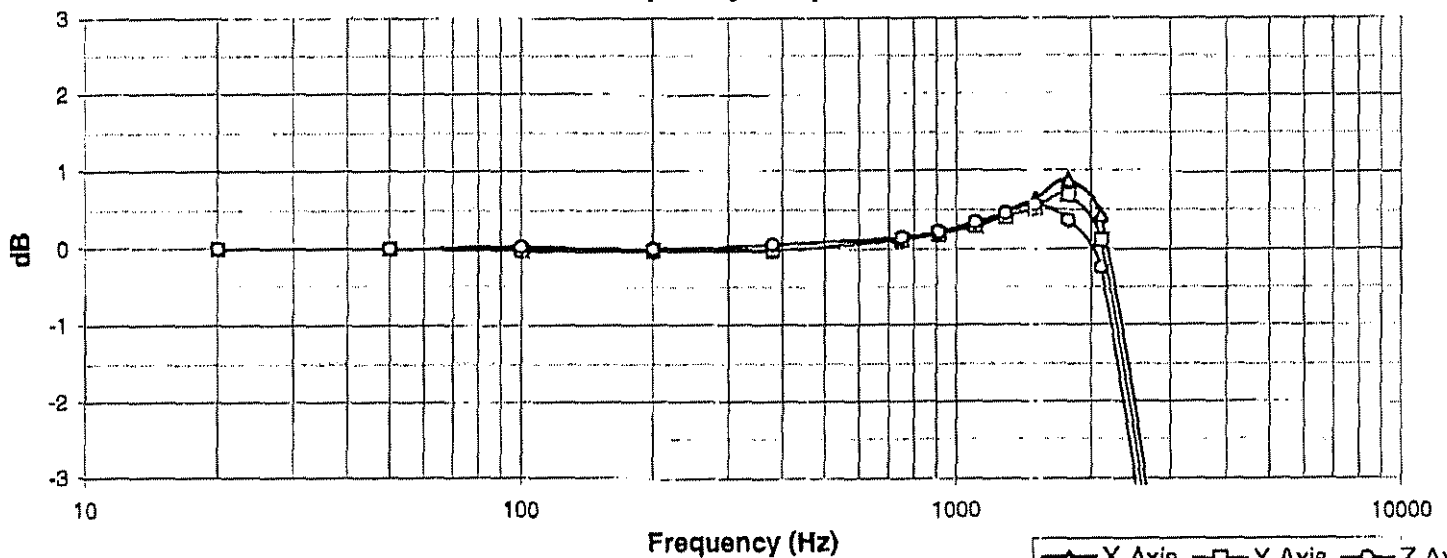

—△— X Axis —□— Y Axis —○— Z Axis

Freq. (Hz)**	20	50	100	200	380	750	910	1100	1285	1500	1775	2100	2900	4000
dB Out - X	-0.002	0	-0.027	-0.028	-0.018	0.112	0.189	0.295	0.461	0.65	0.884	0.43	-4.913	-13.98
dB Out - Y	-0.002	0	-0.023	-0.027	-0.016	0.113	0.188	0.295	0.415	0.523	0.7	0.114	-5.432	-14.97
dB Out - Z	-6E-04	0	0.017	-0.005	0.057	0.144	0.217	0.338	0.458	0.571	0.367	-0.257	-6.089	-15.59

* Reference Frequency is 50 Hz

** 7.071 g Peak Acceleration Traceable to NIST through Vibration Calibration Standard M-90152

Final Status:

Pass:

website: www.silicondesigns.com

e-mail: sales@silicondesigns.com



SILICON DESIGNS INC. 1445 NW Mall St., Issaquah WA 98027-5344, (425) 391-8329, FAX (425) 391-0446

CALIBRATION CERTIFICATE PAGE 2

Model: 2440-025 Part #: 153-00024-02 Full Scale: 25 G
 Serial #: 26 Op. Number: 740 Calibration Date: 09/13/04

Room Temperature Correction Factors:

Y = G's measured X = Output In Volts

Linear Fit:

$$Y = aX + b$$

	X-Axis	Y-Axis	Z-Axis
b	-2.172E-02	7.957E-02	-9.900E-02
a	5.074E+00	5.075E+00	5.025E+00
RMS Error	1.295E-02	1.625E-02	1.921E-02

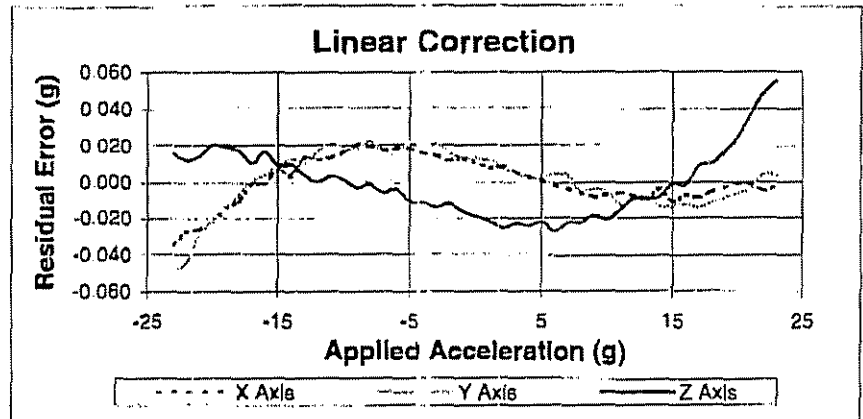

2nd order Fit:

$$Y = a_2 X^2 + a_1 X + b$$

	X-Axis	Y-Axis	Z-Axis
b	-3.190E-02	6.692E-02	-7.957E-02
a ₁	5.074E+00	5.075E+00	5.025E+00
a ₂	1.394E-03	1.732E-03	-2.607E-03
RMS Error	9.406E-03	1.191E-02	9.003E-03

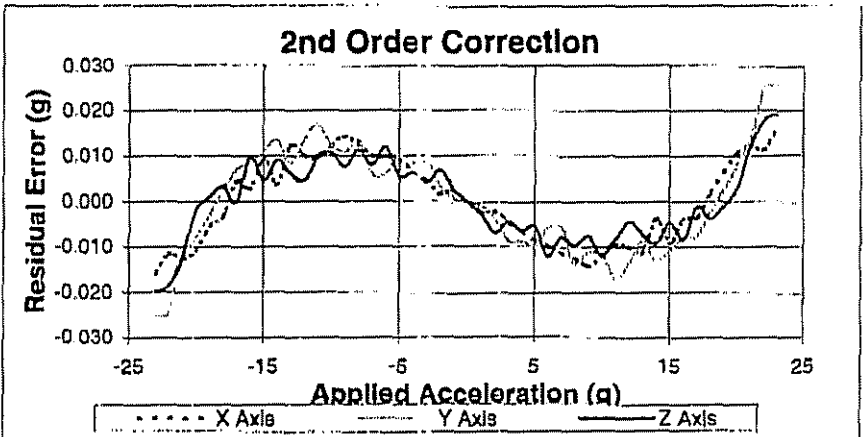

3rd order Fit:

$$Y = a_3 X^3 + a_2 X^2 + a_1 X + b$$

	X-Axis	Y-Axis	Z-Axis
b	-3.192E-02	6.710E-02	-7.975E-02
a ₁	5.081E+00	5.086E+00	5.033E+00
a ₂	1.386E-03	1.687E-03	-2.566E-03
a ₃	-5.938E-04	-7.860E-04	-5.495E-04
RMS Error	2.671E-03	2.518E-03	2.683E-03

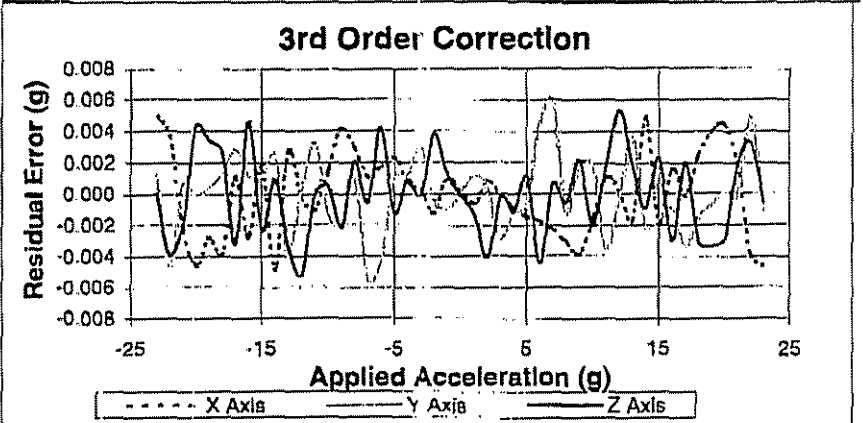

website: www.silicondesigns.com

e-mail: sales@silicondesigns.com



SILICON DESIGNS INC. 1445 NW Mall St., Issaquah WA 98027-5344, (425) 391-8329, FAX (425) 391-0446

Model: 2440-025

CALIBRATION CERTIFICATE

Part #: 153-00024-02 Doc. Rev. -

Mfg. Lot #: 4m242a

Op. Number: 740

	X-Axis	Y-Axis	Z-Axis	
+1 G DC:	218.0	181.0	240.0	mV DC
-1 G DC:	-177.0	-216.0	-158.0	mV DC
0 G Bias:	20.0	-18.0	41.0	mV DC
Scale Factor:	196.50	186.90	198.40	mV/G
Sensor ID:	166774	166772	166777	

Serial #: 27

Operator: lynn

Calibration Date: 09/13/04

Supply Current: 27.3 mA

Full Scale: 25 G

Calibration Freq. 50 Hz

Linearity Error

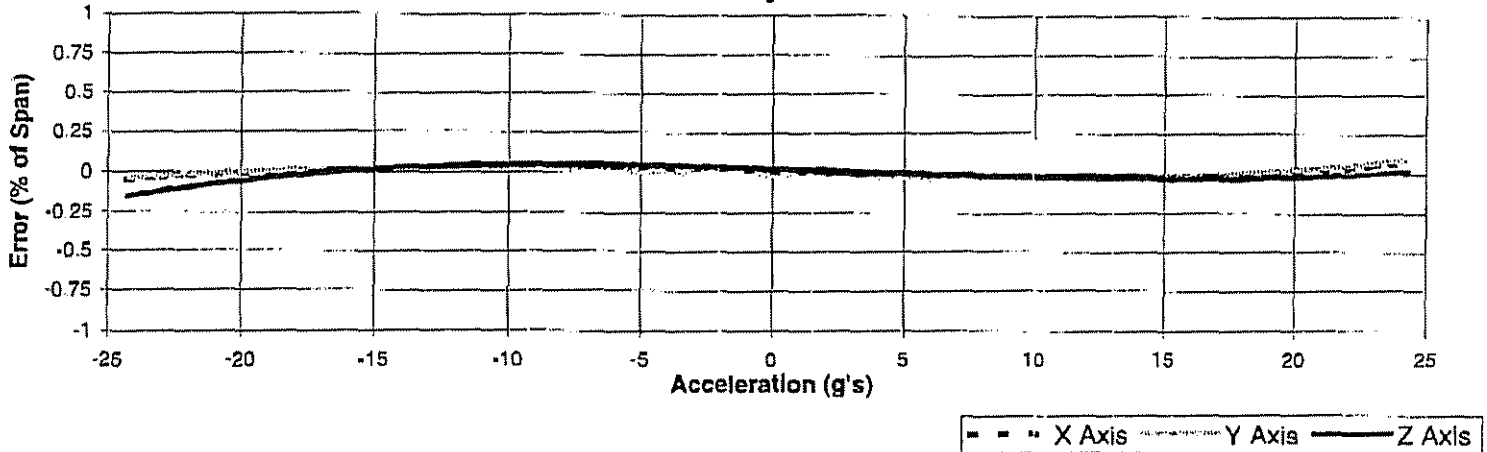

Frequency Response*

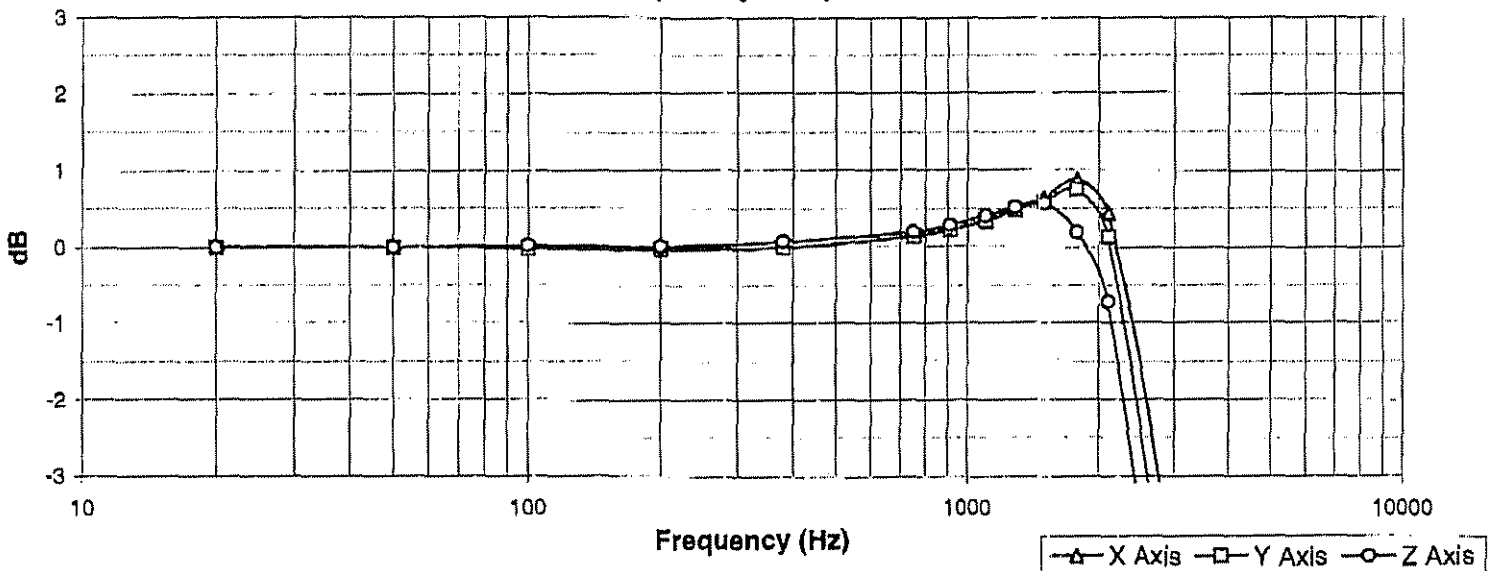

Freq. (Hz)**	20	50	100	200	380	750	910	1100	1285	1500	1775	2100	2900	4000
dB Out - X	-0.003	0	-0.022	-0.029	-0.004	0.142	0.226	0.332	0.486	0.63	0.88	0.441	-3.926	-12.3
dB Out - Y	-0.002	0	-0.021	-0.023	-0.003	0.149	0.233	0.35	0.477	0.585	0.75	0.133	-5.179	-14.21
dB Out - Z	-6E-04	0	0.02	0.005	0.069	0.195	0.281	0.403	0.511	0.562	0.187	-0.727	-6.71	-15.86

* Reference Frequency is 50 Hz

** 7.071 g Peak Acceleration Traceable to NIST through Vibration Calibration Standard M-90152

Final Status:

Pass:

website: www.silicondesigns.com

e-mail: sales@silicondesigns.com



SILICON DESIGNS INC. 1445 NW Mall St., Issaquah WA 98027-5344, (425) 391-8329, FAX (425) 391-0446

CALIBRATION CERTIFICATE PAGE 2

Model: 2440-025 **Part #:** 153-00024-02 **Full Scale:** 25 G
Serial #: 27 **Op. Number:** 740 **Calibration Date:** 09/13/04

Room Temperature Correction Factors:

Y = G's measured X = Output In Volts

Linear Fit:

$$Y = aX + b$$

	X-Axis	Y-Axis	Z-Axis
b	-6.310E-02	5.597E-02	-2.511E-01
a	5.088E+00	5.078E+00	5.041E+00
RMS Error	9.897E-03	1.146E-02	1.948E-02

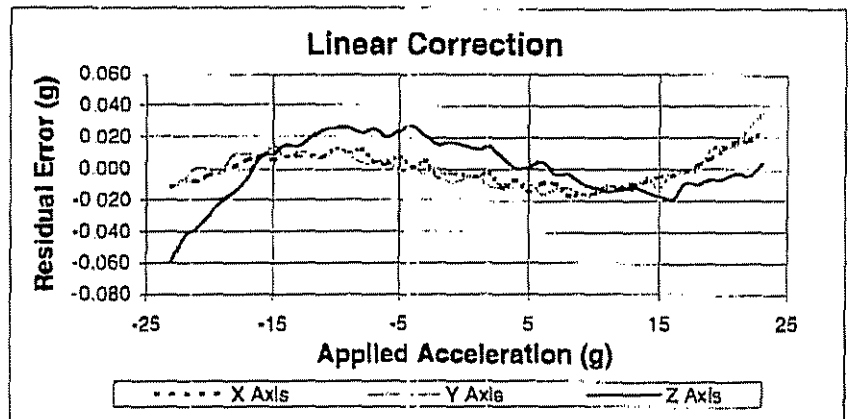

2nd order Fit:

$$Y = a_2 X^2 + a_1 X + b$$

	X-Axis	Y-Axis	Z-Axis
b	-5.950E-02	6.211E-02	-2.661E-01
a₁	5.088E+00	5.078E+00	5.041E+00
a₂	-4.948E-04	-8.426E-04	2.034E-03
RMS Error	9.384E-03	1.012E-02	1.433E-02

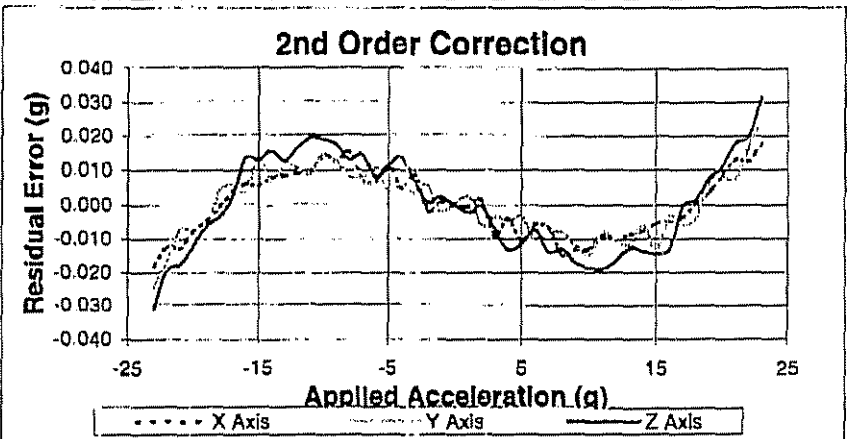

3rd order Fit:

$$Y = a_3 X^3 + a_2 X^2 + a_1 X + b$$

	X-Axis	Y-Axis	Z-Axis
b	-5.961E-02	6.219E-02	-2.667E-01
a₁	5.095E+00	5.086E+00	5.053E+00
a₂	-4.707E-04	-8.603E-04	2.157E-03
a₃	-5.977E-04	-6.412E-04	-9.062E-04
RMS Error	2.591E-03	2.773E-03	2.819E-03

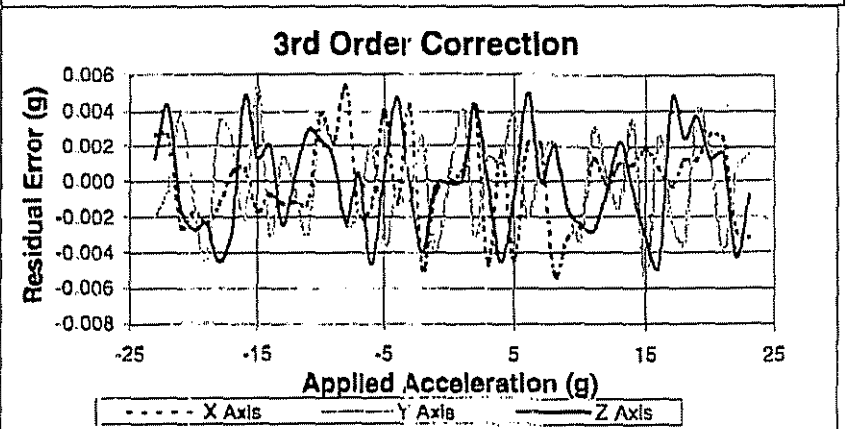

website: www.silicondesigns.com

e-mail: sales@silicondesigns.com



SILICON DESIGNS INC. 1445 NW Mall St., Issaquah WA 98027-5344, (425) 391-8329, FAX (425) 391-0446

CALIBRATION CERTIFICATE

Model: 2440-025

Part #: 153-00024-02 Doc. Rev. -

Mfg. Lot #: 4m242a

Op. Number: 740

Operator: lynn

Serial #: 28

Calibration Date: 09/13/04

Supply Current: 27.7 mA

Full Scale: 25 G

Calibration Freq. 50 Hz

	X-Axis	Y-Axis	Z-Axis	
+1 G DC:	225.0	184.0	226.0	mV DC
-1 G DC:	-170.0	-213.0	-172.0	mV DC
0 G Bias	28.0	-14.0	27.0	mV DC
Scale Factor	197.00	196.70	198.10	mV/G
Sensor ID	165247	165254	166769	

Linearity Error

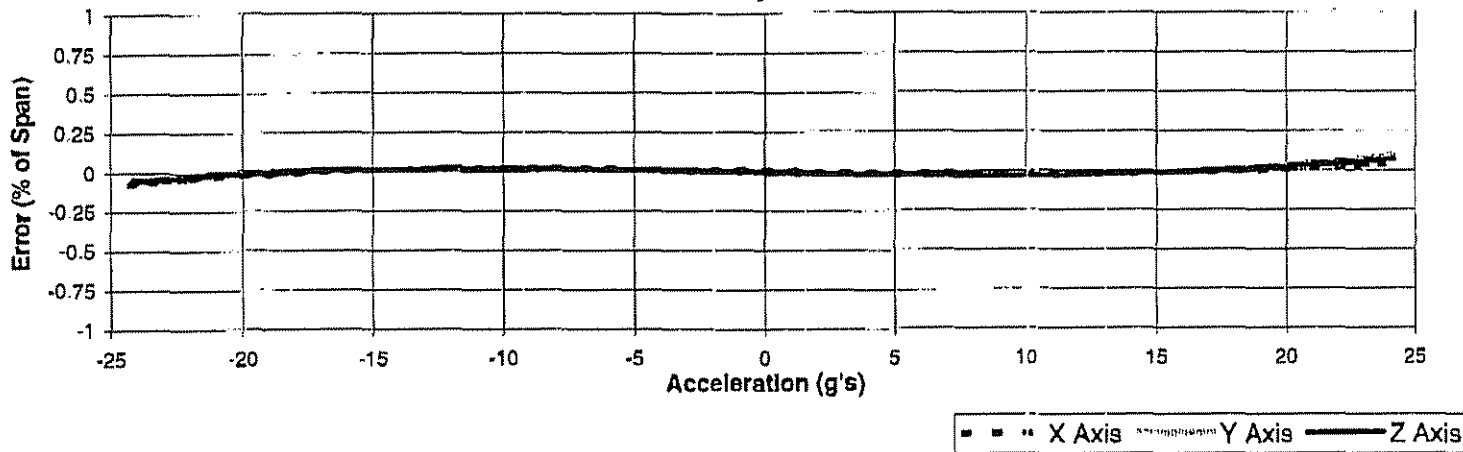

Frequency Response*

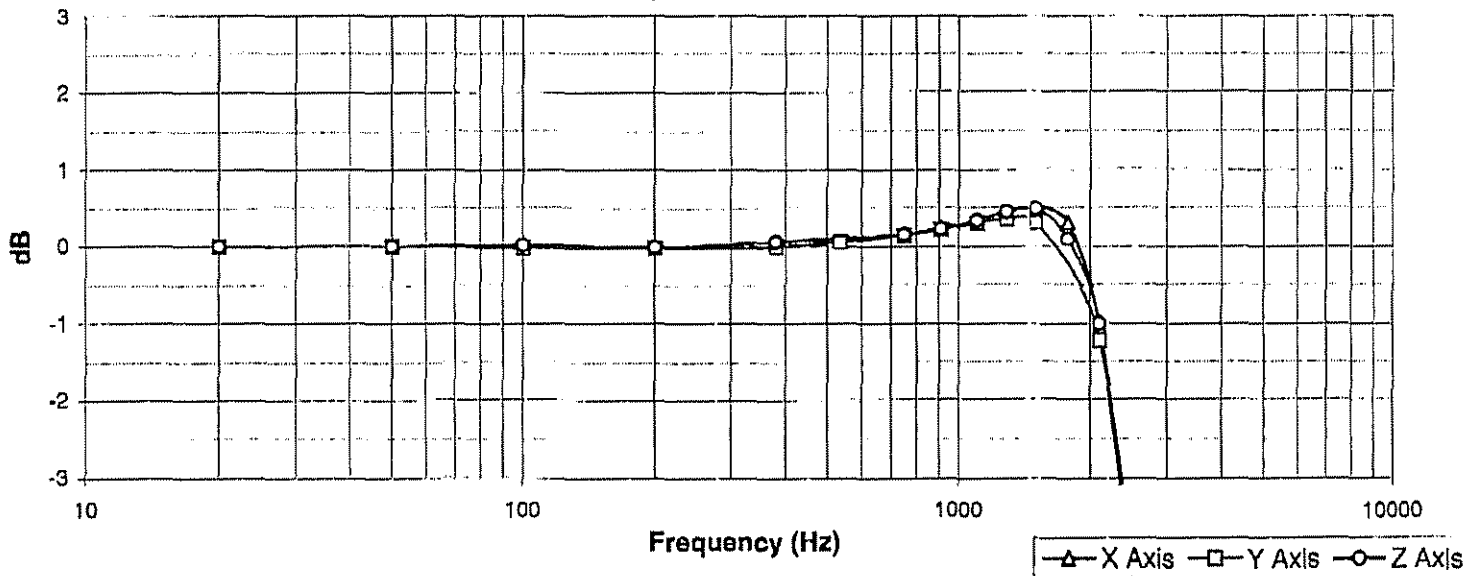

Freq. (Hz)**	20	50	100	200	380	750	910	1100	1285	1500	1775	2100	2900	4000
dB Out - X	-6E-04	0	-0.016	-0.018	-0.005	0.149	0.233	0.326	0.446	0.492	0.307	-1.052	-7.73	-16.87
dB Out - Y	-0.004	0	-0.024	-0.023	-0.005	0.051	0.144	0.216	0.3	0.353	0.3	-1.216	-7.481	-16.5
dB Out - Z	-0.001	0	0.012	-0.009	0.058	0.146	0.22	0.332	0.445	0.49	0.085	-1.008	-7.382	-17.04

* Reference Frequency Is 50 Hz

** 7.071 g Peak Acceleration Traceable to NIST through Vibration Calibration Standard M-90152

Final Status:

Pass:

website: www.silicondesigns.com

e-mail: sales@silicondesigns.com



SILICON DESIGNS INC. 1445 NW Mall St., Issaquah WA 98027-5344, (425) 391-8329, FAX (425) 391-0446

CALIBRATION CERTIFICATE PAGE 2

Model: 2440-025 Part #: 153-00024-02 Full Scale: 25 G
 Serial #: 28 Op. Number: 740 Calibration Date: 09/13/04

Room Temperature Correction Factors:

Y = G's measured X = Output In Volts

Linear Fit:

$$Y = aX + b$$

	X-Axis	Y-Axis	Z-Axis
b	-1.284E-01	5.041E-02	-1.993E-01
a	5.077E+00	5.083E+00	5.049E+00
RMS Error	1.098E-02	1.346E-02	9.817E-03

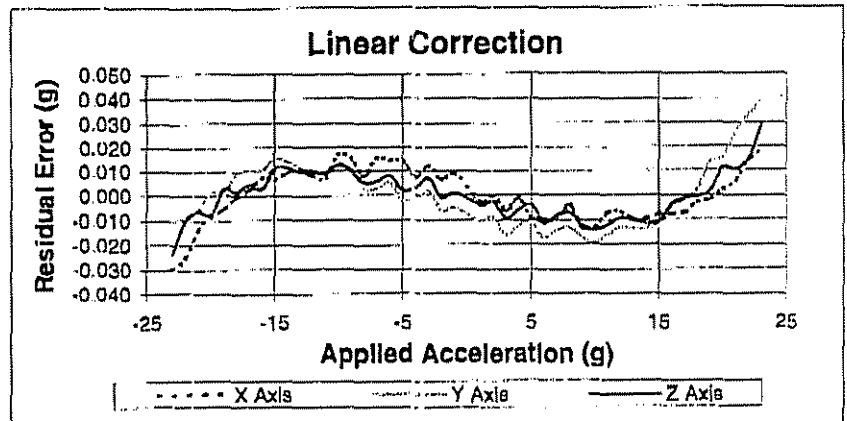

2nd order Fit:

$$Y = a_2 X^2 + a_1 X + b$$

	X-Axis	Y-Axis	Z-Axis
b	-1.315E-01	5.807E-02	-1.978E-01
a ₁	5.077E+00	5.083E+00	5.049E+00
a ₂	4.273E-04	-1.053E-03	-2.125E-04
RMS Error	1.064E-02	1.167E-02	9.721E-03

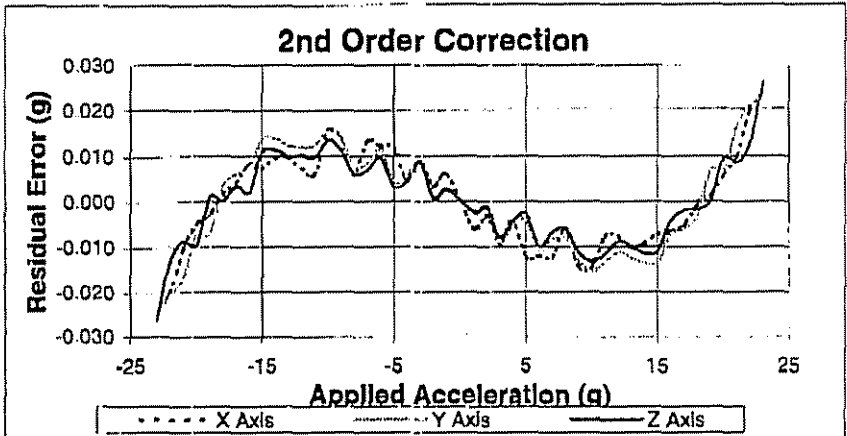

3rd order Fit:

$$Y = a_3 X^3 + a_2 X^2 + a_1 X + b$$

	X-Axis	Y-Axis	Z-Axis
b	-1.317E-01	6.816E-02	-1.981E-01
a ₁	5.085E+00	5.092E+00	5.057E+00
a ₂	4.768E-04	-1.070E-03	-1.398E-04
a ₃	-6.768E-04	-7.530E-04	-6.067E-04
RMS Error	2.757E-03	2.510E-03	2.598E-03

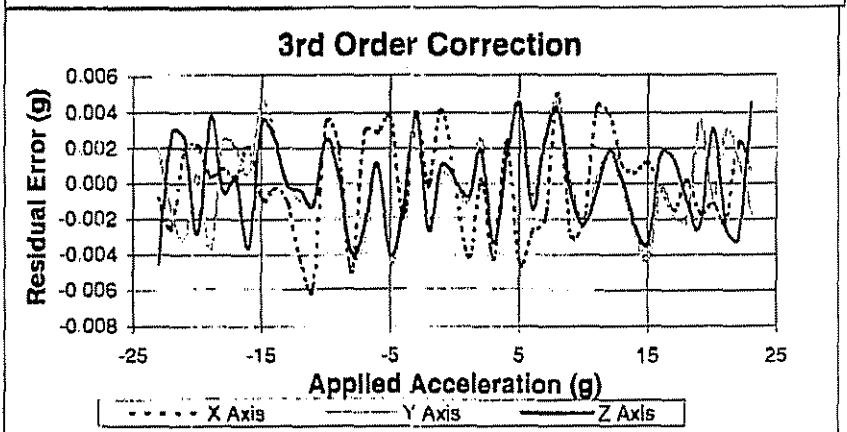

website: www.silicondesigns.com

e-mail: sales@silicondesigns.com



SILICON DESIGNS INC. 1445 NW Mall St., Issaquah WA 98027-5344, (425) 391-8329, FAX (425) 391-0446

CALIBRATION CERTIFICATE

Model: 2440-025

Part #: 153-00024-02 Doc. Rev. -

X-Axis Y-Axis Z-Axis

Mfg. Lot #: 4m242a

Op. Number: 740

+1 G DC: 188.0 214.0 207.0 mV DC

Operator: Iynn

-1 G DC: -207.0 -184.0 -184.0 mV DC

Serial #: 29

Calibration Date: 09/13/04

0 G Bias: -10.0 15.0 6.0 mV DC

Supply Current: 27.2 mA

Scale Factor: 197.00 198.90 198.80 mV/G

Full Scale: 25 G

Calibration Freq. 50 Hz

Sensor ID: 186793 186790 186795

Linearity Error

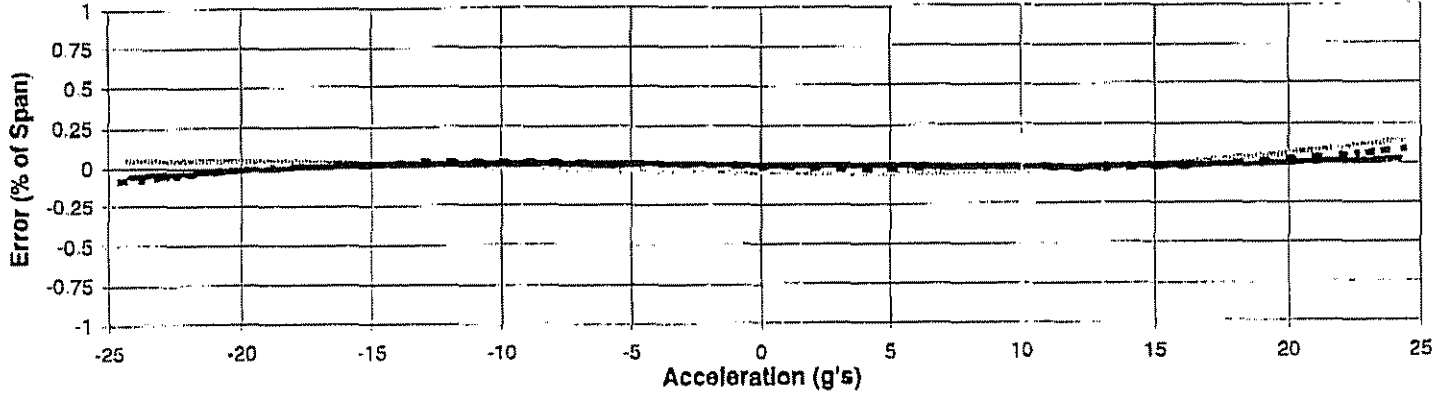

--- X Axis --- Y Axis --- Z Axis

Frequency Response*

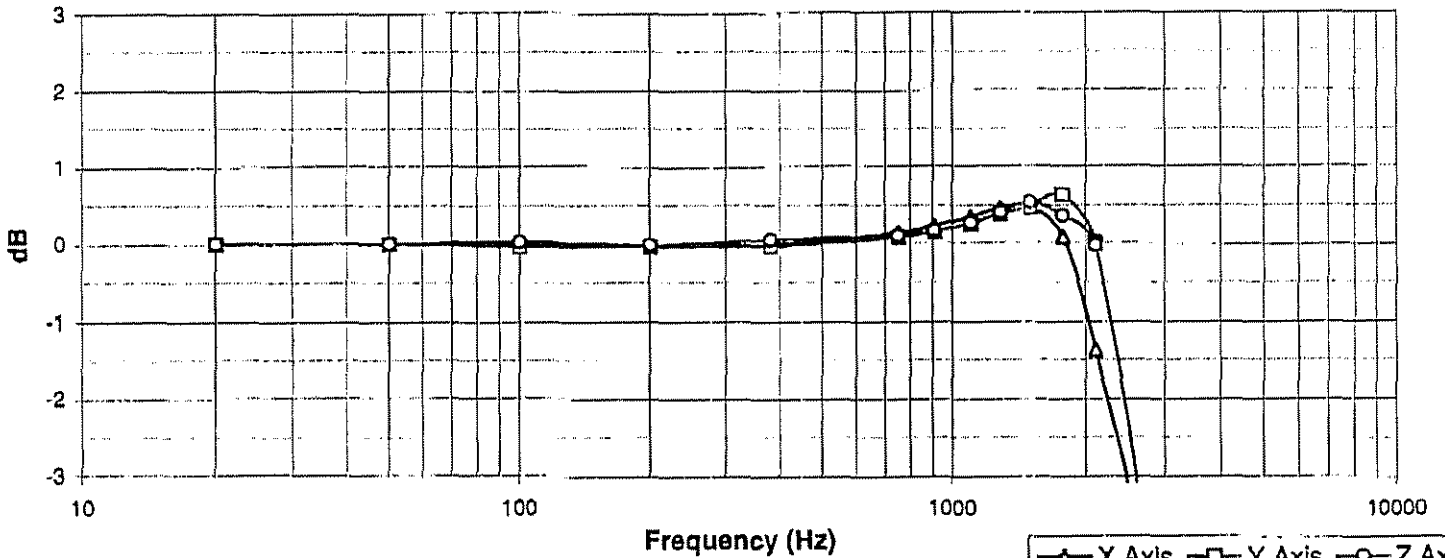

---△--- X Axis ---□--- Y Axis ---○--- Z Axis

Freq. (Hz)**	20	50	100	200	380	750	910	1100	1285	1500	1775	2100	2900	4000
dB Out - X	-0.003	0	-0.004	-0.016	-0.009	0.141	0.234	0.343	0.464	0.468	0.083	-1.369	-5.391	-15.2
dB Out - Y	-0.001	0	-0.04	-0.041	-0.03	0.086	0.156	0.258	0.386	0.472	0.638	0.011	-5.276	-15.3
dB Out - Z	0	0	0.021	-0.014	0.051	0.105	0.168	0.267	0.401	0.535	0.363	-0.025	-5.132	-14.2

* Reference Frequency is 50 Hz

** 7.071 g Peak Acceleration Traceable to NIST through Vibration Calibration Standard M-90152

Final Status:

Pass:

website: www.silicondesigns.com

e-mail: sales@silicondesigns.com



SILICON DESIGNS INC. 1445 NW Mall St., Issaquah WA 98027-5344, (425) 391-8329, FAX (425) 391-0446

CALIBRATION CERTIFICATE PAGE 2

Model: 2440-025 Part #: 153-00024-02 Full Scale: 25 G
 Serial #: 29 Op. Number: 740 Calibration Date: 09/13/04

Room Temperature Correction Factors:

Y = G's measured X = Output In Volts

Linear Fit:

$Y = aX + b$

	X-Axis	Y-Axis	Z-Axis
b	4.742E-02	-7.782E-02	-7.992E-02
a	5.077E+00	5.080E+00	5.036E+00
RMS Error	1.278E-02	2.168E-02	6.251E-03

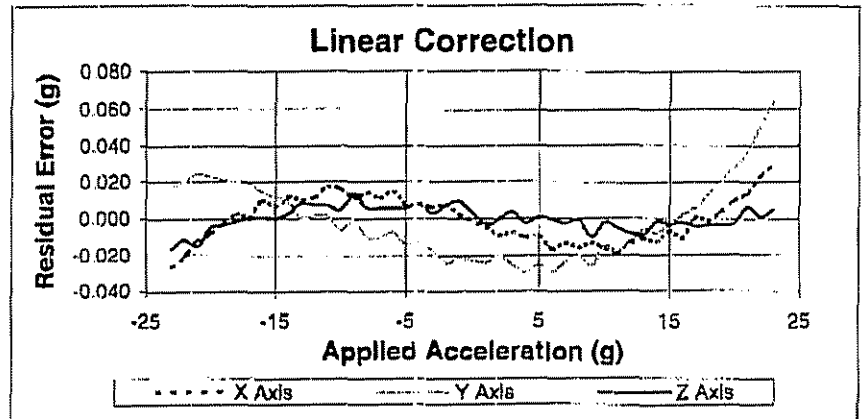

2nd order Fit:

$Y = a_2 X^2 + a_1 X + b$

	X-Axis	Y-Axis	Z-Axis
b	4.834E-02	-5.505E-02	-8.319E-02
a ₁	5.077E+00	5.080E+00	5.036E+00
a ₂	-1.263E-04	-3.125E-03	4.410E-04
RMS Error	1.275E-02	8.628E-03	5.559E-03

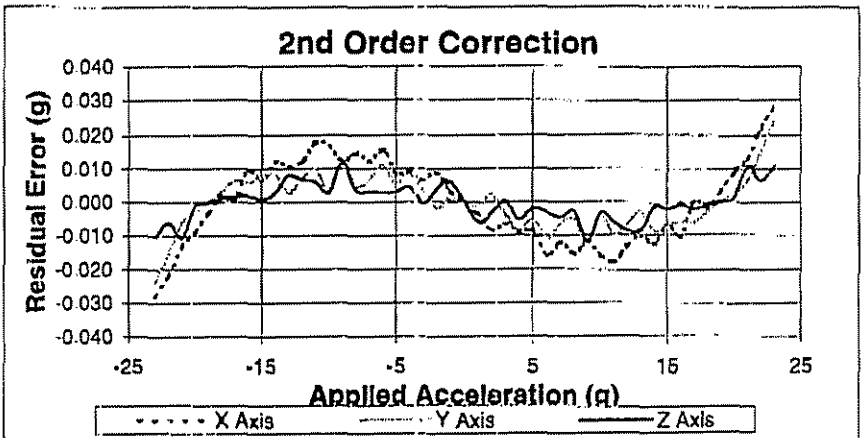

3rd order Fit:

$Y = a_3 X^3 + a_2 X^2 + a_1 X + b$

	X-Axis	Y-Axis	Z-Axis
b	4.844E-02	-5.519E-02	-8.326E-02
a ₁	5.088E+00	5.087E+00	5.040E+00
a ₂	-1.488E-04	-3.090E-03	4.551E-04
a ₃	-8.270E-04	-5.308E-04	-3.132E-04
RMS Error	2.241E-03	3.133E-03	2.683E-03

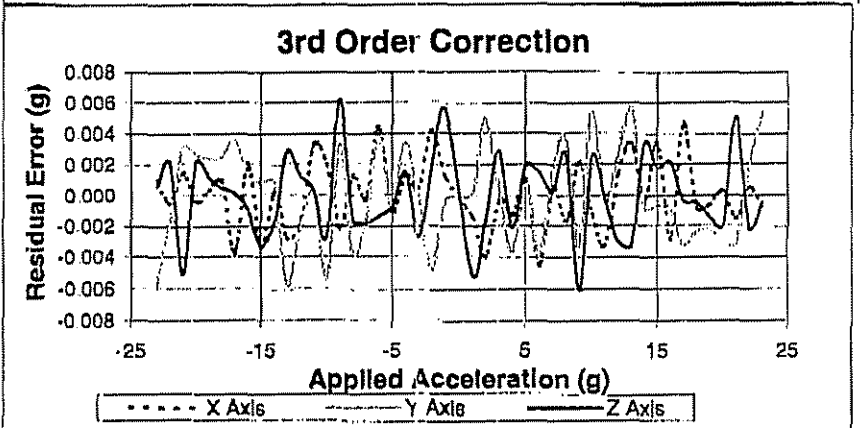

website: www.silicondesigns.com

e-mail: sales@silicondesigns.com

Calibration Certificate

Transverse Sensitivity(%): 0.8

Temperature (deg C): 23
Relative Humidity (%): 47
Input Resistance (ohms): 584
Output Resistance (ohms): 598
ZMO (mV): -3.7
Resonance Frequency (Hz): 16787

Document number: 83572

Description: 4 Arm PR accelerometer
Manufacturer: ENDEVCO
Model Number: 7264B-500T
Serial Number: B15071

Sensitivity:

0.7447 mV/g @ 100 Hz, 10 g pk
0.07594 mV/ m/s² @ 100 Hz, 98 m/s² pk

Excitation: 10.0 V

Notes:

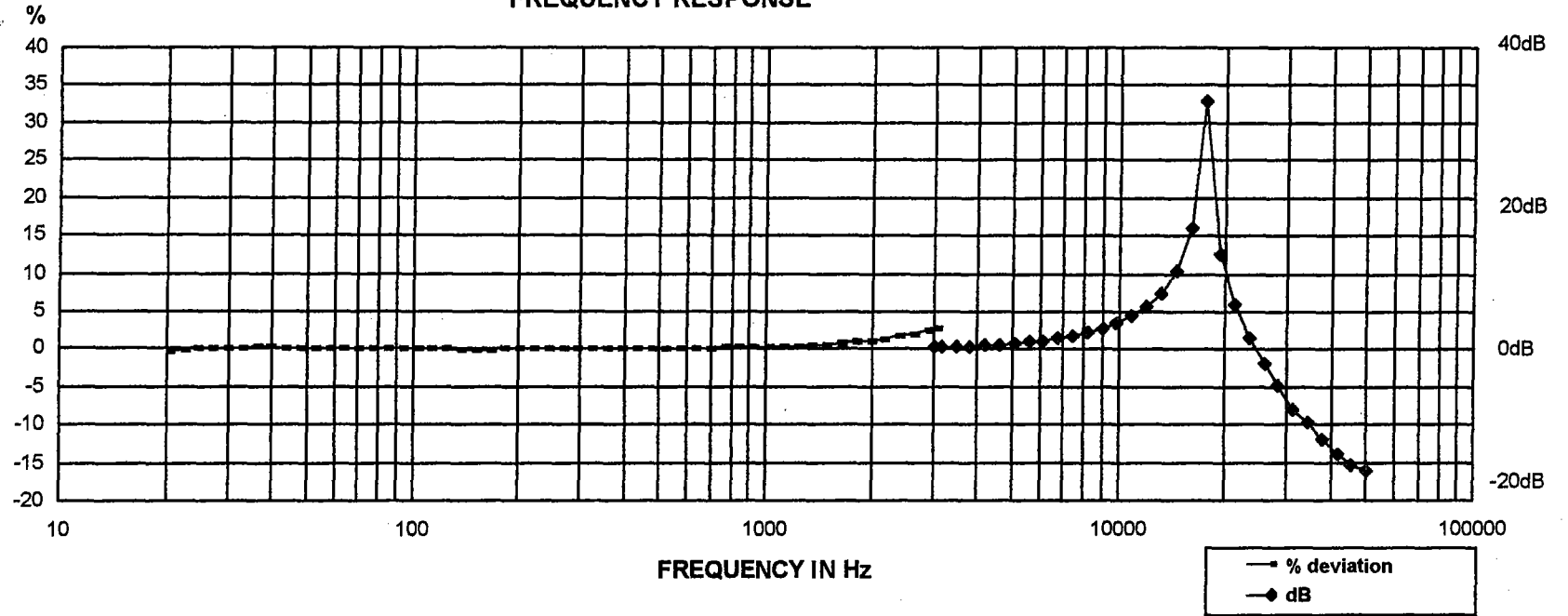

FREQUENCY RESPONSE



Endevco, a division of Meggitt, located at 30700 Rancho Viejo Road, San Juan Capistrano, CA, certifies that the above instrument was tested using comparison calibrations per ANSI S2.2 using Endevco IM68357. This calibration is traceable to the National Institute of Standards and Technology and is in accordance with ANSI/NCSL Z540-1-1994 (MIL-STD 45662A).

Console serial number: AC23
Equipment used: 2901
Ref Manufacturer: ENDEVCO
Ref Model number: 2270M7A/2771A-10
Ref Serial number: AC56/DP46
NIST traceability #: 822/271199-05
Test Name: FINAL 2901 REV C
ED421 Rev D

Uncertainty estimate (95% confidence, k=2)
+/- 1.2 % 100.0 Hz Sensitivity
+/- 1.5 % 20.0 < f <= 100.0 Hz
+/- 1.2 % 100.0 < f <= 2500.0 Hz
+/- 2.5 % 2500.0 < f <= 10000.0 Hz
+/- 5.0 % 10000.0 < f <= 20000.0 Hz

By:  
operator Name and Title
3/7/2005 10:20 AM

PE SBU
s/w 7.03

Calibration Certificate

ENDEVCO, a leading authority in precision dynamic measurement, certifies that this instrument meets or exceeds all published specifications

This instrument has been calibrated using standards with accuracies traceable to the National Institute of Standards and Technology (NIST) within the limitations of their calibration services, or have been derived from accepted values or natural physical constraints, or have been derived by ratio or self-calibration techniques.

All activities performed in this calibration comply with ISO/IEC 17025-2000 and ANSI/NCSL Z540-1-1994 (MIL-STD 45662A).



Robert Meyer
President

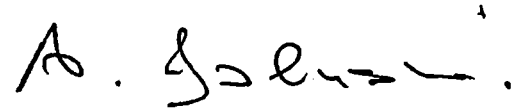

Alex Johnstone
Director, Product Assurance

 MEGGITT

ENDEVCO 

An ISO-9001 Certified Company



195 Clarksville road
 Princeton Jct., NJ 08550-5303
 Ph: (609) 716-4130
 customerservice@vibrametrics.com

ACCELEROMETER CALIBRATION CERTIFICATE

The unit was calibrated at VibraMetrics Laboratory. Measuring and test equipment used in the calibration is traceable to the U.S. National Institute of Standards and Technology. Documentation relative to traceability is on file at this office and is available for examination upon request. Do not reproduce except in full, without written approval

Calibration Proc. #: QOP-760-01 **Customer's Name:**

Quality Assurance: _____

Model No.	Serial No.	By	Date	Basic Sensitivity (mv/g) @ 100 Hz (measured)	Bias Level(volts)	Noise Floor(uv/rms)
7002HG2K	0867	LW	6/7/2005	9.9	11.9	
Freq. Reponse +/-5%	Freq. Response +/-3db	Resonant Freq. (KHz)	Transverse Sensitivity	Mounting Torque (in-lbs)	NIST Test Number	Power Supply
N/A	2Hz to 2 KHz	N/A	<5%	20	822/268064-03	2 mA @ 24

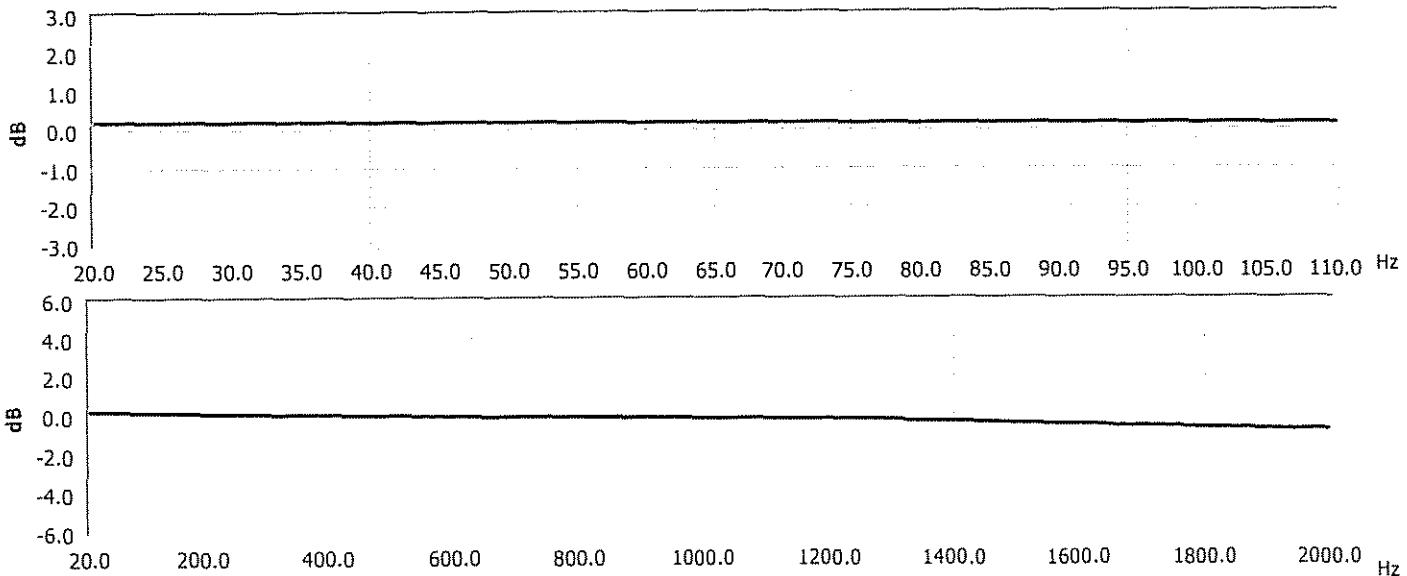



Vibra-Metrics®

A Member of MISTRAS Holdings Group

ACCELEROMETER CALIBRATION CERTIFICATE

Model No.	Serial No.	Operator	Date	Basic Sensitivity (mV/g) @ 100 Hz	Bias Level(volt)	Noise Floor(µV/rtm)
7002HG2K	0902	LW	5/24/2005	9.5	11.3	
Freq. Response +/-5%	Freq. Response +/-3db	Resonant Freq. (KHz)	Transverse Sensitivity	Mounting Torque (in-lbs)	NIST Test Number	Power Supply
N/A	2Hz to 2 KHz	N/A	<5%	20	822/268064-03	2 mA @ 24

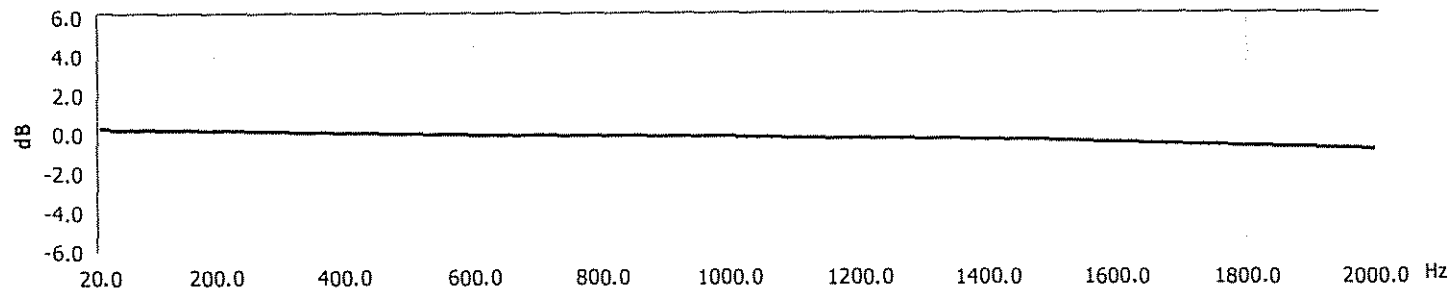
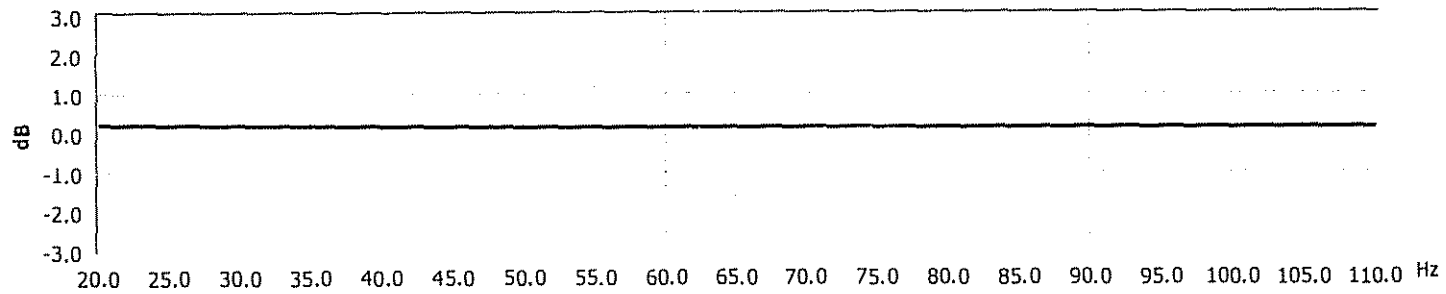

POWER SUPPLY CERTIFICATE OF CALIBRATION

We hereby certify that the power supply described below has been calibrated in compliance with the system requirements defined by ANSI/NCSL Z540-1, as amended. Calibration instrumentation used is maintained in accordance with ISO 10012-1, being directly traceable to N.I.S.T. Documentation supporting this traceability is at our facility and available upon request.

MODEL: LP-24-3B SERIAL NUMBER: 182
LED is on

MEASURED CURRENT SOURCE OF $2.2\text{mA} \pm 0.3\text{Ma}$ is:
"X" = 2.2, "Y" = 2.2, "Z" = 2.2.

MEASURED VOLTAGE AT INPUT OF $24\text{VDC} \pm 1.2\text{V}$ is: 24.0V
"X" = 24.0, "Y" = 24.0V, "Z" = 24.0V

FUNCTIONAL TEST USING SCOPE, FOR SIGNAL DISTORTION:

TECHNICIAN: P.A.M



TEST DATE: 6/9/05

QUALITY VERIFICATION STAMP:



ACCEPTANCE DATE: 6/6/05

AUTHORIZED SIGNATURE: Dejae Bena

TITLE: Quality Inspector

QUALITY ASSURANCE DEPT.

QAF-LP24,REV.-



Dytran Instruments, Inc.
 21592 Marilla St Chatsworth, CA 91311 Ph: 818-700-7818 Fax 818-700-7880
 www.dytran.com email: info@dytran.com

CALIBRATION CERTIFICATE UNITY GAIN CURRENT SOURCE POWER UNIT

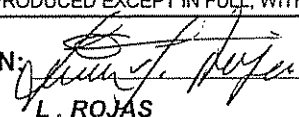
CUSTOMER: ENSCO, INC.				TEST REPORT #: 1005				5/18/2005							
PURCHASE ORDER #: 85737			SALES ORDER #: 119156			PROCEDURE: TP4023									
MODEL: 4110C				SERIAL #: 1005											
BATTERY POWERED		LINE POWERED		X		115VAC		X		230VAC					
NEW UNIT		X		RE-CALIBRATION [1]		AS RECEIVED CODE		AS RETURNED CODE							
TEMPERATURE (°C): 22						HUMIDITY (%): 35									
CALIBRATION DATA															
POWER SUPPLY VOLTAGE (VDC): 24.0						BATTERY VOLTAGE (VDC):									
METER ZERO		X		METER CALIBRATION				X							
SENSOR DRIVE CURRENT (mA)															
CH 1		CH 2		CH 3		CH 4		CH 5		CH 6		CH 7		CH 8	
5.0															
CH 9		CH 10		CH 11		CH 12		CH 13		CH 14		CH 15		CH 16	
AS RECEIVED DATA															
GENERAL CONDITION:															
POWER SUPPLY VOLTAGE (VDC):						BATTERY VOLTAGE (VDC):									
METER CALIBRATION				REPLACED BATTERIES				YES		NO					
SENSOR DRIVE CURRENT (mA)															
CH 1		CH 2		CH 3		CH 4		CH 5		CH 6		CH 7		CH 8	
CH 9		CH 10		CH 11		CH 12		CH 13		CH 14		CH 15		CH 16	
NOTES:															
TEST EQUIPMENT LIST - CALIBRATION STATION # 6															
DII #	MANUFACTURER	MODEL	SERIAL #	DESCRIPTION	CAL DATE	DUE DATE									
228	DYTRAN INST	4515	117	SENSOR SIMULATOR	06/07/04	06/07/05									
464	KENWOOD	CS-4135	5100491	OSCILLOSCOPE	07/28/04	07/28/05									
418	KIETHLEY	197A	0765030	DIGITAL MULTIMETER	06/23/04	06/23/05									
564	INSTEK	GFG 8020H	D675835	FUNCTION GENERATOR	12/28/04	12/28/05									
[1] AS RECEIVED / AS RETURNED CODES: 1 = IN TOLERANCE. NO ADJUSTMENTS 3 = OUT OF TOLERANCE 5 = REPAIRED AND CALIBRATED 2 = IN TOLERANCE. BUT ADJUSTED 4 = REPAIR RECOMMENDED 6 = NON-REPAIRABLE. REPLACEMENT RECOMMENDED															
THIS CALIBRATION WAS PERFORMED IN ACCORDANCE WITH MIL-STD-45662A, ANSI/NCSL Z540-1-1994, ISO 10012-1 AND IS TRACEABLE TO THE NIST (NATIONAL INSTITUTE OF STANDARDS AND TECHNOLOGY) THIS CERTIFICATE SHALL NOT BE REPRODUCED EXCEPT IN FULL, WITHOUT THE WRITTEN PERMISSION FROM DYTRAN INSTRUMENTS, INC.															
CALIBRATION TECHNICIAN:  L. ROJAS						TEST DATE: 05/18/05 RECALL DATE: 05/18/06									



Dytran Instruments, Inc.

21592 Marilla St. Chatsworth, CA 91311 Ph: 818-700-7818 Fax 818-700-7880
www.dytran.com email: info@dytran.com

CALIBRATION CERTIFICATE VOLTAGE MODE ACCELEROMETER

CUSTOMER: ENSCO, INC.		TEST REPORT #: 12361		5/18/05
PURCHASE ORDER #: 85737		SALES ORDER #: 119156		PROCEDURE: TP3002
MODEL: 3030B4		SERIAL #: 12361		RANGE, F.S. (g's): +/- 500
NEW UNIT	X	RE-CALIBRATION [1]	AS RECEIVED CODE	AS RETURNED CODE
REF. SENSITIVITY (mV/g) [2]: 10.10		TEMP (°C): 22		HUMIDITY (%): 38

FREQUENCY RESPONSE [3]

FREQUENCY (Hz)	SENSITIVITY (mV/g)	FREQUENCY (Hz)	SENSITIVITY (mV/g)
20	10.10	500	10.10
30	10.10	1000	10.10
50	10.10	3000	10.10
100	10.10	5000	10.00
300	10.10	8000	10.00
TRANSVERSE SENSITIVITY (%): 1.2		10000	10.10
DISCHARGE TIME CONSTANT (sec): 0.50		BIAS VOLTAGE (VDC): 8.9	

Amplitude Response

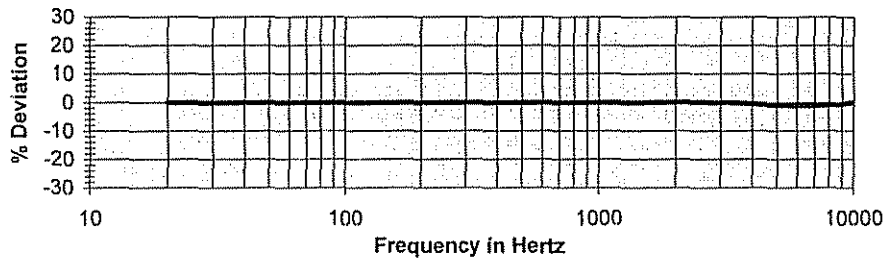

REMARKS:

TEST EQUIPMENT LIST - CALIBRATION STATION # 3

DII #	MANUFACTURER	MODEL	SERIAL #	DESCRIPTION	CAL DATE	DUE DATE
565	INSTEK	FG-8016G	D685002	FUNCTION GENERATOR	12/28/04	12/28/05
389	GOODWILL INST.	GOS-622G	9631068	OSCILLOSCOPE	12/04/04	12/04/05
286	FLUKE	45	7025037	MULTIMETER	12/04/04	12/04/05
213	TRIG-TEK	346B	115	SYNTHESIZED CALIBRATOR	02/23/05	02/23/06
443	NICOLET	3091	85D01977	DIGITAL OSCILLOSCOPE	08/17/04	08/17/05
976	DYTRAN INST.	3010M8	976	ACCELEROMETER	06/17/04	06/17/05

- [1] AS RECEIVED / AS RETURNED CODES:
- 1 = IN TOLERANCE. NO ADJUSTMENTS
 - 2 = IN TOLERANCE. BUT ADJUSTED
 - 3 = OUT OF TOLERANCE < 5%
 - 4 = OUT OF TOLERANCE > 5%
 - 5 = REPAIR REQUIRED
 - 6 = REPAIRED AND CALIBRATED
 - 7 = UNIT NON-REPAIRABLE, RECOMMEND REPLACEMENT
 - 8 = UNIT SERVICEABLE WITH CURRENT CALIBRATION DATA

[2] THE REFERENCE SENSITIVITY IS MEASURED AT 100 Hz. 1G RMS
 [3] THIS CALIBRATION WAS PERFORMED IN ACCORDANCE WITH MIL-STD-45662A. ANS/NCNSL Z540-1-1994, ISO 10012-1 USING THE BACK-TO-BACK COMPARISON METHOD PER ISA RP37 2 AND IS TRACEABLE TO THE NIST THROUGH TEST REPORT # 822/270316-04 DUE 06-17-05
 ESTIMATED UNCERTAINTY OF CALIBRATION: 2% FROM 5-50 Hz. 1% FROM 100-2000 Hz. 2% FROM 2.5-10 kHz.
 THIS CERTIFICATE SHALL NOT BE REPRODUCED EXCEPT IN FULL, WITHOUT THE WRITTEN PERMISSION FROM DYTRAN INSTRUMENTS, INC.

CALIBRATION TECHNICIAN: <u>Hung Le</u>	TEST DATE: 05/18/05
HUNG LE	RECALL DATE: 05/18/06

~ Calibration Certificate ~

Per ISO 16063-21

Model Number: J353B01

Serial Number: 95258

Description: ICP® Accelerometer

Method: Back-to-Back Comparison Calibration

Manufacturer: PCB

Calibration Data

Sensitivity @ 100.0 Hz	19.69 mV/g	Output Bias	8.4 VDC
	(2.008 mV/m/s ²)	Transverse Sensitivity	1.7 %
Discharge Time Constant	0.8 seconds	Resonant Frequency	41.7 kHz

Sensitivity Plot

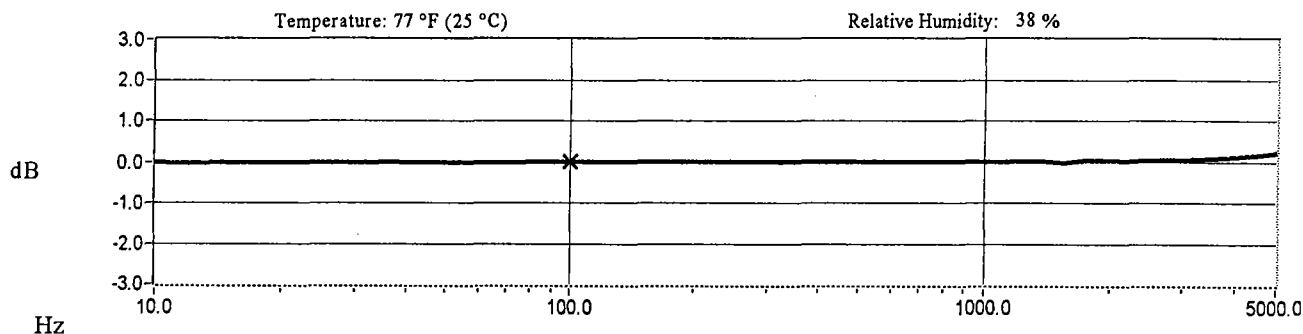

Data Points

Frequency (Hz)	Dev. (%)	Frequency (Hz)	Dev. (%)
10.0	-0.2	300.0	0.1
15.0	-0.2	500.0	0.1
30.0	-0.2	1000.0	0.1
50.0	-0.2	3000.0	0.6
REF. FREQ.	0.0	5000.0	2.6

Mounting Surface: Stainless Steel w/Silicone Grease Coating Fastener: Stud Mount
 Acceleration Level (rms): 10.0 g (98.1 m/s²)

Fixture Orientation: Vertical

*The acceleration level may be limited by shaker displacement at low frequencies. If the listed level cannot be obtained, the calibration system uses the following formula to set the vibration amplitude; Acceleration Level (g) = 0.010 x (freq).
 *The gravitational constant used for calculations by the calibration system is; 1 g = 9.8066 m/s².

Condition of Unit

As Found: n/a

As Left: New Unit, In Tolerance

Notes

1. Calibration is NIST Traceable thru Project 822/267400 and PTB Traceable thru Project 1055.
2. This certificate shall not be reproduced, except in full, without written approval from PCB Piezotronics, Inc.
3. Calibration is performed in compliance with ISO 9001, ISO 10012-1, ANSI/NCSL Z540-1-1994 and ISO 17025.
4. See Manufacturer's Specification Sheet for a detailed listing of performance specifications.
5. Measurement uncertainty (95% confidence level with coverage factor of 2) for frequency ranges tested during calibration are as follows: 5-9 Hz; +/- 2.0%, 10-99 Hz; +/- 1.5%, 100-1999 Hz; +/- 1.0%, 2-10 kHz; +/- 2.5%.

Technician: Mary Warren Date: 10/29/04



3425 Walden Avenue Depew, NY 14043
 TEL: 888-684-0013 FAX: 716-685-3886 www.pcb.com

~ Calibration Certificate ~

Per ISO 16063-21

Model Number: J353B01

Serial Number: 97687

Description: ICP® Accelerometer

Method: Back-to-Back Comparison Calibration

Manufacturer: PCB

Calibration Data

Sensitivity @ 100.0 Hz	20.21 mV/g	Output Bias	8.6 VDC
	(2.061 mV/m/s ²)	Transverse Sensitivity	1.3 %
Discharge Time Constant	0.8 seconds	Resonant Frequency	72.5 kHz

Sensitivity Plot

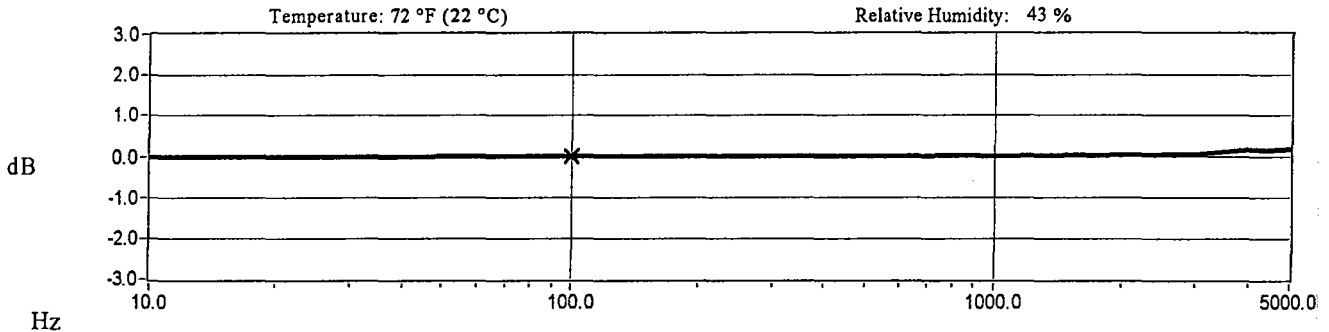

Data Points

Frequency (Hz)	Dev. (%)	Frequency (Hz)	Dev. (%)
10.0	-0.2	300.0	0.1
15.0	-0.1	500.0	0.1
30.0	-0.1	1000.0	0.1
50.0	-0.0	3000.0	0.6
REF. FREQ.	0.0	5000.0	2.0

Mounting Surface: Stainless Steel w/Silicone Grease Coating Fastener: Stud Mount
 Acceleration Level (rms): 10.0 g (98.1 m/s²)

Fixture Orientation: Vertical

*The acceleration level may be limited by shaker displacement at low frequencies. If the listed level cannot be obtained, the calibration system uses the following formula to set the vibration amplitude; Acceleration Level (g) = 0.010 x (freq).
 *The gravitational constant used for calculations by the calibration system is; 1 g = 9.8066 m/s².

Condition of Unit

As Found: n/a

As Left: New Unit, In Tolerance

Notes

1. Calibration is NIST Traceable thru Project 822/267400 and PTB Traceable thru Project 1055.
2. This certificate shall not be reproduced, except in full, without written approval from PCB Piezotronics, Inc.
3. Calibration is performed in compliance with ISO 9001, ISO 10012-1, ANSI/NCSL Z540-1-1994 and ISO 17025.
4. See Manufacturer's Specification Sheet for a detailed listing of performance specifications.
5. Measurement uncertainty (95% confidence level with coverage factor of 2) for frequency ranges tested during calibration are as follows: 5-9 Hz; +/- 2.0%, 10-99 Hz; +/- 1.5%, 100-1999 Hz; +/- 1.0%, 2-10 kHz; +/- 2.5%.

Technician: Alan Koetzle Date: 10/26/04



3425 Walden Avenue Depew, NY 14043

TEL: 888-684-0013 FAX: 716-685-3886 www.pcb.com

~ Calibration Certificate ~

Per ISO 16063-21

Model Number: J353B01

Serial Number: 97688

Description: ICP® Accelerometer

Method: Back-to-Back Comparison Calibration

Manufacturer: PCB

Calibration Data

Sensitivity @ 100.0 Hz	20.41 mV/g	Output Bias	8.6 VDC
	(2.082 mV/m/s ²)	Transverse Sensitivity	1.1 %
Discharge Time Constant	0.7 seconds	Resonant Frequency	72.4 kHz

Sensitivity Plot

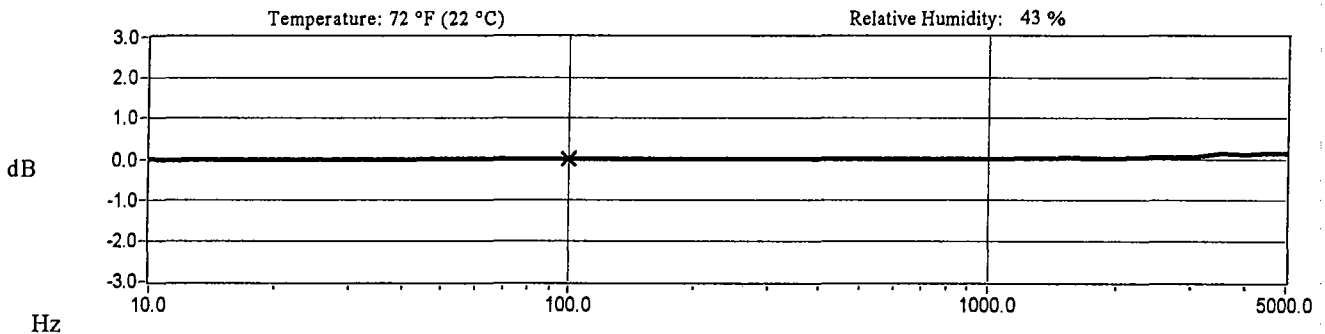

Data Points

Frequency (Hz)	Dev. (%)	Frequency (Hz)	Dev. (%)
10.0	0.1	300.0	0.0
15.0	-0.1	500.0	0.1
30.0	-0.1	1000.0	0.1
50.0	-0.0	3000.0	0.6
REF. FREQ.	0.0	5000.0	1.7

Mounting Surface: Stainless Steel w/Silicone Grease Coating Fastener: Smd Mount
 Acceleration Level (rms): 10.0 g (98.1 m/s²)

Fixture Orientation: Vertical

*The acceleration level may be limited by shaker displacement at low frequencies. If the listed level cannot be obtained, the calibration system uses the following formula to set the vibration amplitude: Acceleration Level (g) = 0.010 x (freq).
 *The gravitational constant used for calculations by the calibration system is; 1 g = 9.8066 m/s².

Condition of Unit

As Found: n/a

As Left: New Unit, In Tolerance

Notes

1. Calibration is NIST Traceable thru Project 822/267400 and PTB Traceable thru Project 1055.
2. This certificate shall not be reproduced, except in full, without written approval from PCB Piezotronics, Inc.
3. Calibration is performed in compliance with ISO 9001, ISO 10012-1, ANSI/NCSL Z540-1-1994 and ISO 17025.
4. See Manufacturer's Specification Sheet for a detailed listing of performance specifications.
5. Measurement uncertainty (95% confidence level with coverage factor of 2) for frequency ranges tested during calibration are as follows: 5-9 Hz; +/- 2.0%, 10-99 Hz; +/- 1.5%, 100-1999 Hz; +/- 1.0%, 2-10 kHz; +/- 2.5%.

Technician: Alan Koetzle AK Date: 10/26/04



3425 Walden Avenue Depew, NY 14043

TEL: 888-684-0013 FAX: 716-685-3886 www.pcb.com

~ Calibration Certificate ~

Per ISO 16063-21

Model Number: J353B31

Serial Number: 97690

Description: ICP® Accelerometer

Method: Back-to-Back Comparison Calibration

Manufacturer: PCB

Calibration Data

Sensitivity @ 100.0 Hz	51.4 mV/g	Output Bias	9.2 VDC
	(5.24 mV/m/s ²)	Transverse Sensitivity	0.5 %
Discharge Time Constant	0.6 seconds	Resonant Frequency	36.3 kHz

Sensitivity Plot

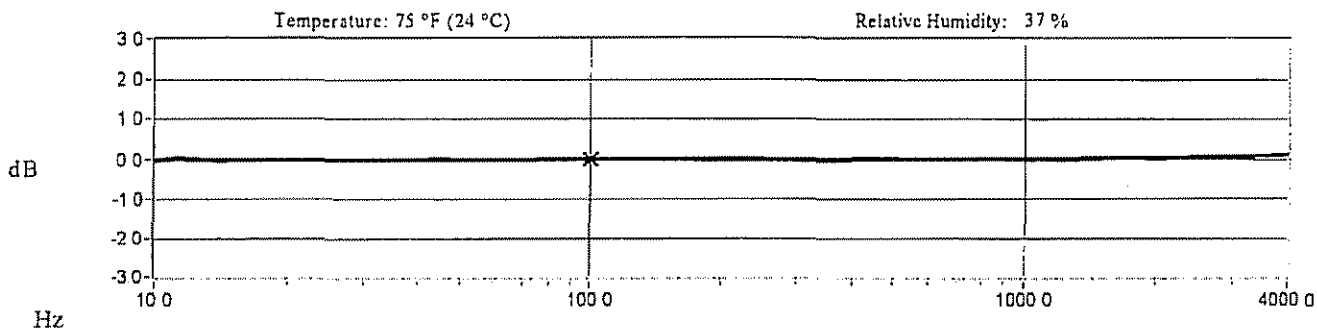

Data Points

Frequency (Hz)	Dev (%)	Frequency (Hz)	Dev (%)
10.0	-0.4	300.0	-0.1
15.0	-0.2	500.0	0.1
30.0	-0.1	1000.0	0.1
50.0	-0.1	3000.0	0.8
REF. FREQ	0.0	4000.0	1.3

Mounting Surface: Stainless Steel w/Silicone Grease Coating Fixture: Stud Mount

Fixture Orientation: Vertical

Acceleration Level (ms⁻²): 10.0 g (98.1 m/s²)

*The acceleration level may be limited by shaker displacement at low frequencies. If the listed level cannot be obtained, the calibration system uses the following formula to set the vibration amplitude: Acceleration Level(g) = 0.010 x (freq)².
*The gravitational constant used for calculations by the calibration system is: 1 g = 9.80665 m/s²

Condition of Unit

As Found: n/a

As Left: New Unit, In Tolerance

Notes

1. Calibration is NIST Traceable thru Project 822/267400 and PTB Traceable thru Project 1055.
2. This certificate shall not be reproduced, except in full, without written approval from PCB Piezotronics, Inc.
3. Calibration is performed in compliance with ISO 9001, ISO 10012-1, ANSI/NCSL Z540-1-1994 and ISO 17025
4. See Manufacturer's Specification Sheet for a detailed listing of performance specifications
5. Measurement uncertainty (95% confidence level with coverage factor of 2) for frequency ranges tested during calibration are as follows: 5-9 Hz; +/- 2.0%, 10-99 Hz; +/- 1.5%, 100-1999 Hz; +/- 1.0%, 2-10 kHz; +/- 2.5%

Technician: Robert Zsebezay R. Z. Date: 10/21/04



3425 Walden Avenue Depew, NY 14043

TEL: 888-684-0013 FAX: 716-685-3886 www.pcb.com

~ Calibration Certificate ~

Per ISO 16063-21

Model Number: J353B31

Serial Number: 97691

Description: ICP® Accelerometer

Method: Back-to-Back Comparison Calibration

Manufacturer: PCB

Calibration Data

Sensitivity @ 100.0 Hz	49.9 mV/g	Output Bias	9.2 VDC
	(5.08 mV/m/s ²)	Transverse Sensitivity	2.1 %
Discharge Time Constant	0.9 seconds	Resonant Frequency	35.0 kHz

Sensitivity Plot

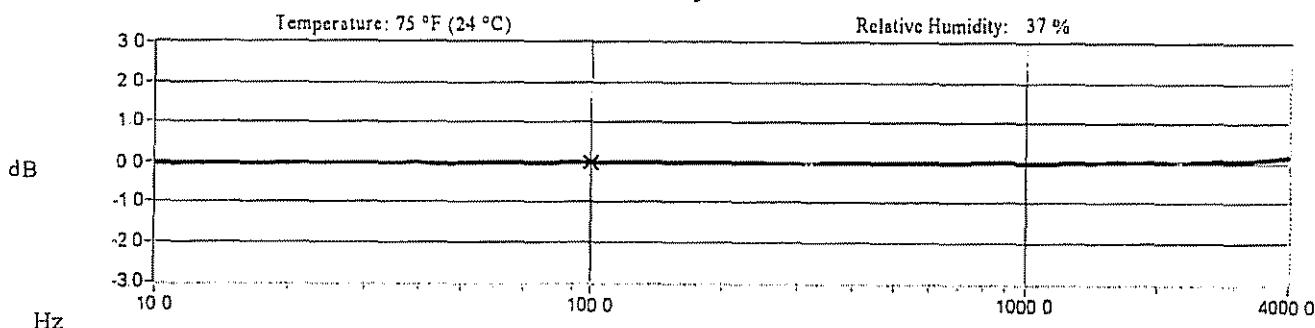

Data Points

Frequency (Hz)	Dev (%)	Frequency (Hz)	Dev (%)
10.0	-0.4	300.0	-0.1
15.0	-0.3	500.0	0.1
30.0	-0.2	1000.0	0.1
50.0	-0.2	3000.0	0.8
REF FREQ.	0.0	4000.0	1.8

Mounting Surface: Stainless Steel w/Silicone Grease Coating Fastener: Stud Mount

Fixture Orientation: Vertical

Acceleration Level (m/s²): 10.0 g (98.1 m/s²)

The acceleration level may be limited by shaker displacement at low frequencies. If the listed level cannot be obtained, the calibration system uses the following formula to set the vibration amplitude: Acceleration Level (g) = 0.010 x (f[Hz])^{1.5}
 The gravitational constant used for calculations by the calibration system is: 1 g = 9.8066 m/s²

Condition of Unit

As Found: n/a

As Left: New Unit, In Tolerance

Notes

1. Calibration is NIST Traceable thru Project 822/267400 and PTB Traceable thru Project 1055.
2. This certificate shall not be reproduced, except in full, without written approval from PCB Piezotronics, Inc
3. Calibration is performed in compliance with ISO 9001, ISO 10012-1, ANSI/NCSL Z540-1-1994 and ISO 17025
4. See Manufacturer's Specification Sheet for a detailed listing of performance specifications
5. Measurement uncertainty (95% confidence level with coverage factor of 2) for frequency ranges tested during calibration are as follows: 5-9 Hz; +/- 2.0%, 10-99 Hz; +/- 1.5%, 100-1999 Hz; +/- 1.0%, 2-10 kHz; +/- 2.5%.

Technician: Robert Zsebezhay R.Z. Date: 10/21/04



3425 Walden Avenue Depew, NY 14043

TEL: 888-684-0013 FAX: 716-685-3886 www.pcb.com

rtd4 - 3181257559.51

~ Calibration Certificate ~

Per ISO 16063-21

Model Number: J353B31

Serial Number: 97692

Description: ICP® Accelerometer

Method: Back-to-Back Comparison Calibration

Manufacturer: PCB

Calibration Data

Sensitivity @ 100.0 Hz	50.2 mV/g (5.12 mV/m/s ²)	Output Bias	9.2 VDC
		Transverse Sensitivity	0.4 %
Discharge Time Constant	0.8 seconds	Resonant Frequency	35.5 kHz

Sensitivity Plot

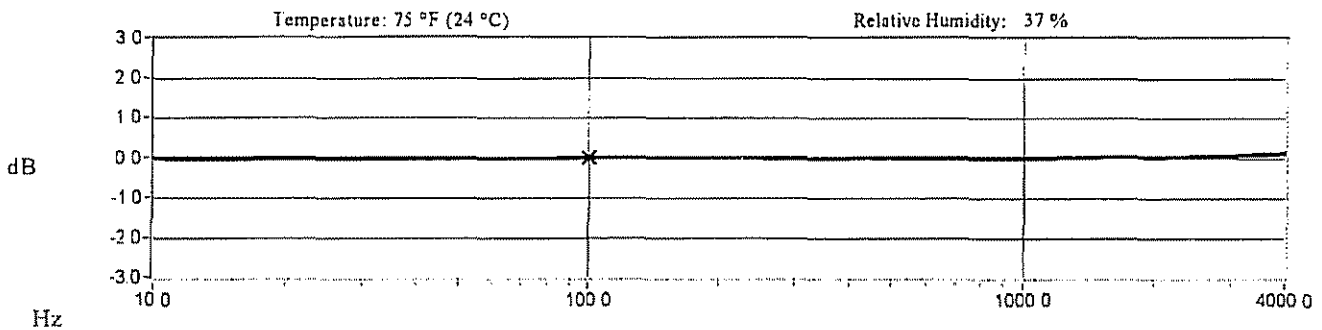

Data Points

Frequency (Hz)	Dev. (%)	Frequency (Hz)	Dev. (%)
10.0	-0.2	300.0	-0.1
15.0	-0.3	500.0	0.1
30.0	-0.2	1000.0	0.1
50.0	-0.1	3000.0	0.8
REF. FREQ.	0.0	4000.0	1.4

Mounting Surface: Stainless Steel w/Silicone Grease Coating Fastener: SMD Mount
Acceleration Level (rms): 10.0 g (98.1 m/s²)

Fixture Orientation: Vertical

*The acceleration level may be limited by shaker displacement at low frequencies. If the listed level cannot be obtained, the calibration system uses the following formula to set the vibration amplitude: Acceleration Level (g) = 0.010 x (freq)^{1.5}
*The gravitational constant used for calculations by the calibration system is: 1 g = 9.8066 m/s²

Condition of Unit

As Found: n/a

As Left: New Unit, In Tolerance

Notes

- 1 Calibration is NIST Traceable thru Project 822/267400 and PTB Traceable thru Project 1055
- 2 This certificate shall not be reproduced, except in full, without written approval from PCB Piezotronics, Inc
- 3 Calibration is performed in compliance with ISO 9001, ISO 10012-1, ANSI/NCSS Z540-1-1994 and ISO 17025.
- 4 See Manufacturer's Specification Sheet for a detailed listing of performance specifications.
- 5 Measurement uncertainty (95% confidence level with coverage factor of 2) for frequency ranges tested during calibration are as follows: 5-9 Hz; +/- 2.0%, 10-99 Hz; +/- 1.5%, 100-1999 Hz; +/- 1.0%, 2-10 kHz; +/- 2.5%

Technician: Robert Zsebeazy R.Z. Date: 10/21/04



3425 Walden Avenue Depew, NY 14043

TEL: 888-684-0013 FAX: 716-685-3886 www.pcb.com

OMEGADYNE INC.

PRESSURE TRANSDUCER
FINAL CALIBRATION

0 - 200.00 PSIG
Excitation 15.000 Vdc

Job: Model: PX41C1-200G10T Date: 1/19/2004 Calibrated: 0.00 - 200.00 PSIG
Serial: 148187 Tested By: BOB Temperature Range: 60 to 160 F Specfile: PX41-10T

Pressure PSIG	Unit Data Vdc
0.00	0.0003
100.00	5.0142
200.00	10.0067
100.00	5.0157
0.00	0.0004

Balance 0.0003 Vdc
Sensitivity 10.0064 Vdc

ELECTRICAL LEAKAGE: PASS
PRESSURE CONNECTION/FITTING: 1/4-18 NPT MALE
ELECTRICAL WIRING/CONNECTOR: PIN A = +OUTPUT
PIN B =* -OUTPUT
PIN C = -INPUT (EXC)
PIN D = +INPUT (EXC)

This Calibration was performed using Instruments and Standards that are traceable to the United States National Institute of Standards Technology.

S/N	Description	Range	Reference	Cal Cert
C-2020	PPB Pressure Console	0 - 500 lbs	C-2020	C-2020
US36087645	HP34401A DMM	UUT Unit Under Test	C-2485	
3146A22561	HP34401A DMM	STD Pressure Monitor	C-2409	

Q.A. Representative : *Robert Smith* Date: 1-19-05
This transducer is tested to & meets published specifications. After final calibration our products are stored in a controlled stock room & considered in bonded storage. Depending on environment & severity of use factory calibration is recommended every one to three years after initial service installation date

Omegadyne, Inc., 149 Stelzer Court, Sunbury, OH 43074 (740) 965-9340
http://www.omegadyne.com email: info@omegadyne.com (800) USA-DYNE

OMEGADYNE INC.

PRESSURE TRANSDUCER
FINAL CALIBRATION

0 - 200.00 PSIG
Excitation 15.000 Vdc

Job: Model: PX41C1-200G10T Date: 6/27/03
Calibrated: 0.00 - 200.00 PSIG
Serial: 148201
Tested By: BEN
Temperature Range: 60 to 160 F
Specfile: Px41-10T.spf

Pressure PSIG	Unit Data Vdc
0.00	- 0.002
100.00	5.004
200.00	9.998
100.00	5.005
0.00	- 0.003

Balance - 0.002 Vdc
Sensitivity 10.000 Vdc

ELECTRICAL LEAKAGE: PASS
PRESSURE CONNECTION/FITTING: 1/4-18 NPT MALE
ELECTRICAL WIRING/CONNECTOR: PIN A +OUTPUT
PIN B -OUTPUT
PIN C -INPUT
PIN D +INPUT
PINS E&F NC

This Calibration was performed using Instruments and Standards that are traceable to the United States National Institute of Standards Technology.

S/N	Description	Range	Reference	Cal Cert
0078/90-03	1000 PSI DRUCK	STD 0 - 1000 lbs	C-2501	C-2501
MY41005	AT34970A DMM UUT	Unit Under Test	C-2470	

Q.A. Representative : *D.A. [Signature]* Date: 6-27-03
This transducer is tested to & meets published specifications. After final calibration our products are stored in a controlled stock room & considered in bonded storage. Depending on environment & severity of use factory calibration is recommended every one to three years after initial service installation date

Omegadyne, Inc., 149 Stelzer Court, Sunbury, OH 43074 (740) 965-9340
http://www.omegadyne.com email: info@omegadyne.com (800) USA-DYNE

OMEGADYNE INC.

PRESSURE TRANSDUCER
FINAL CALIBRATION

0 - 200.00 PSIG
Excitation 28.000 Vdc

Job: Model: PX41C1-200G10T Date: 6/27/03
Calibrated: 0.00 - 200.00 PSIG
Serial: 148202
Tested By: BEN
Temperature Range: 60 to 160 F
Specfile: Px41-10T.spf

Pressure PSIG	Unit Data Vdc
0.00	0.000
100.00	5.009
200.00	10.000
100.00	5.010
0.00	0.001

Balance 0.000 Vdc
Sensitivity 10.000 Vdc

ELECTRICAL LEAKAGE: PASS
PRESSURE CONNECTION/FITTING: 1/4-18 NPT MALE
ELECTRICAL WIRING/CONNECTOR: PIN A +OUTPUT
PIN B -OUTPUT
PIN C -INPUT
PIN D +INPUT
PINS E&F NC

This Calibration was performed using Instruments and Standards that are traceable to the United States National Institute of Standards Technology.

S/N	Description	Range	Reference	Cal Cert
0078/90-03	1000 PSI DRUCK	STD 0 - 1000 lbs	C-2501	C-2501
MY41005	AT34970A DMM UUT	Unit Under Test	C-2470	

Q.A. Representative : *[Signature]* Date: 6-27-03
This transducer is tested to & meets published specifications. After final calibration our products are stored in a controlled stock room & considered in bonded storage. Depending on environment & severity of use factory calibration is recommended every one to three years after initial service installation date

Omegadyne, Inc., 149 Stelzer Court, Sunbury, OH 43074 (740) 965-9340
http://www.omegadyne.com email: info@omegadyne.com (800) USA-DYNE

GENERAL INFORMATION: WK-SERIES STRAIN GAGES

GENERAL DESCRIPTION: WK-Series gages are a family of fully encapsulated K-alloy strain gages used in both experimental stress analysis and transducer applications. These gages have integral high-endurance lead ribbons with a backing and encapsulation matrix consisting of a high-temperature epoxy-phenolic resin system reinforced with glass fiber.

TEMPERATURE RANGE: -452° to +550° F (-268° to +289° C) for continuous use in static measurements. Useful to +700° F (+370° C) for short term exposure.

SELF TEMPERATURE COMPENSATION: See data curve below.

STRAIN LIMITS: ±1.5% at room temperature; ±1.0% at -320° F (-195° C).

FATIGUE LIFE: 10⁷ cycles at ±2000 μin/in (μm/m); 10⁸ cycles at ±2200 μin/in (μm/m). Longer gage lengths and lower resistances show greater endurance and less scatter in fatigue life.

BONDING AGENTS: High-temperature epoxy adhesives are recommended for best performance over the entire temperature range. Micro-Measurements M-Bond 610, 600 and M-Bond GA-60 are particularly compatible with WK-Series gages. Refer to M-M Catalog A-110 for information on bonding agents, and Bulletin B-130 for installation procedures.

LEADWIRE SYSTEM: Two flat, high-endurance leads attached to each tab permit 3-wire or 4-wire systems to be carried directly to the gage, minimizing leadwire errors over the wide useful temperature range of the WK-Series strain gages. Option SP-30 WK-Series gages are supplied with single 0.005 in. (0.13 mm) diameter nickel-clad copper wire leads. Option SP-30 reduces fatigue life of WK-Series gages and should not be selected where best cycle endurance is required. Internal tab connections on these gages are made with +770° F (+410° C) solder. Leadwires may be soft soldered, spot-welded or silver soldered. Refer to M-M Bulletin B-132 for information on solders.

G038

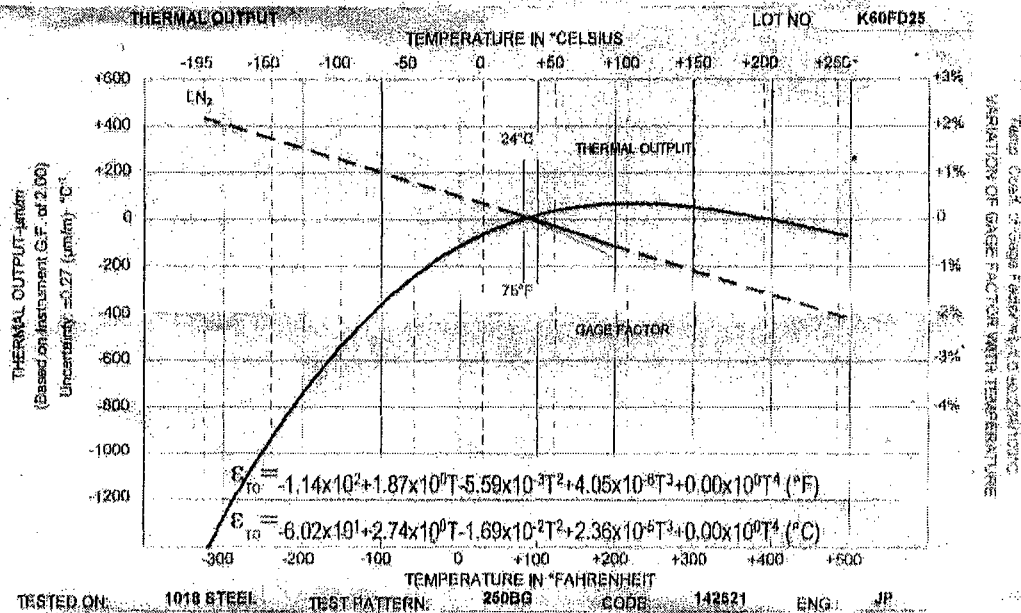

OPTICAL DEFECT ANALYSIS	M-M Procedure and Standards
GAGE RESISTANCE AT 24°C AND 60% RH	M-M Procedure, Direct NIST Traceability on Resistance Standards
GAGE FACTOR AT 24°C & 60% RH (UNIAxIAL STRESS FIELD - POISSON RATIO = 0.285)	ASTM E-251 (Constant Stress Cantilever Method)
TEMPERATURE COEFFICIENT OF GAGE FACTOR	ASTM E-261 (Step Deflection Method)
THERMAL OUTPUT	ASTM E-261 (Slow Heating Rate, Continuously Recorded)
TRANSVERSE SENSITIVITY AT 24°C AND 60% RH	ASTM E-251
FATIGUE LIFE	NAS-942 (Modified)
STRAIN LIMITS	NAS-942 (Modified)
GAGE THICKNESS	M-M Procedure
CREEP AND DRIFT	M-M Procedure (Similar to NAS 942 Method)

NOTE: Gage resistance, gage factor, temperature coefficient of gage factor, thermal output, and transverse sensitivity testing and information presented are in compliance with MIL-STD-1316 (formerly MIL-STD-1316). Performance characteristics of low-resistance strain gages. Other tests are not included in I.R. 131. 82

T001

An OMEGA Technologies Company

Certificate of Calibration

Infrared Thermometer

OMEGA Engineering, Inc. certifies that the instrument referenced above has been fully inspected, tested and calibrated prior to shipment in accordance with the instruction manual supplied. OMEGA Engineering further certifies that this instrument meets or exceeds all of the published electrical, mechanical and operational performance characteristics.

All tests and calibrations were performed with instruments, equipment, and standards that are traceable to the U.S. National Institute of Standards and Technology.

Specifically, this instrument is accurate to within:

- $\pm 1\%$ of reading, or 3°F whichever is greater.

Accepted By: Todd Pratt

OMEGA Engineering, Inc., One Omega Drive, Box 4047, Stamford, CT 06907-0047
Tel: (203) 359-1660 • Fax: (203) 359-7811
www.omega.com e-mail: info@omega.com

Acela Brake Disc Test - Post Test Instrumentation Evaluation

Boston, MA May 16th, 2005

Personnel Performing Evaluation:

Randall Wingate – Knorr Brake Corporation

Frank Hellmer – Knorr Brake Corporation

Boris Nejikovskiy, ENSCO, Inc

Eric Sherrock, ENSCO, Inc

Bill Jordan, ENSCO, Inc

1. Visual evaluation

All sensors mounted on the axle and bearing adapters were visually inspected. No physical damage was found. All accelerometers mountings are solid. All bolts are tight.

2. Impact test

The purpose of the test is to verify that accelerometers and the corresponding measurement channels provide the whole required measurement range (i.e. do not saturate). The sensors mounted on the bearing adapters have been mechanically removed for the test. Electrically the sensors were still connected to data acquisition system. The test was performed by subjecting accelerometers to successively higher impacts until the measurement range was reached. The ENSCO triaxial accelerometer (Silicon Design, Inc., Model 2430-100, range +/-100g) was removed and tested on impact. Levels of up to 70 to 80g were observed with no saturation.

3. Vibration test

The purpose of the test is to verify sensor linearity over the frequency range. The test was performed using a portable shaker (Hardy Instruments, Model DI-803) that allows to set amplitude and frequency of vibration in the range 10Hz to 1KHz). The following table shows the test results

ENSCO accelerometer evaluation

	Shaker setting	Shaker setting	ENSCO System measurement	ENSCO System measurement
	Freq	Ampl	Freq	Ampl
	50Hz	5.0g	50Hz	5g
	100Hz	9.97g	100Hz	9.9g
	200Hz	9.97g	200Hz	10.1g
	500Hz	10g	500Hz	7.5g

Due to mounting configuration only the Vertical acceleration was verified. The Lateral acceleration will be verified post-test.

4. Accelerometer channel frequency sweep

A signal generator (Agilent 3312A serial# MY40027658) was connected to all SCU sensor inputs. A 2V peak to peak sinewave was injected in all inputs. The frequency of a sine waveform was swept through 10, 50, 100, 200, 300, 400, 500, 600, 700, 800, 900, 1000, 1100, 1200Hz frequencies. The roll-off of all channels is at 500Hz. The roll-off acceleration measured value of the axle mounted accelerometer was 35.32 g. The axle mounted accelerometer has a 19.7 mv/g calibrated scale factor with a 1v peak equals 50.76 g and a measured value of 50.56 g.

Conclusion: All instrumentation tested as described above performed in an acceptable manner. There is no evidence of any data quality issues.

ENSCO, Inc.

Boris Nejikovsky
Chief Engineer

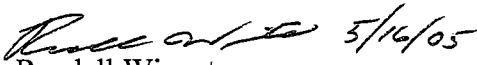

Eric Sherrock
Senior Engineer

Knorr Brake Corporation

 5/16/05
Randall Wingate
Test Engineer

 05/16/05
Frank Hellmer
Test Engineer

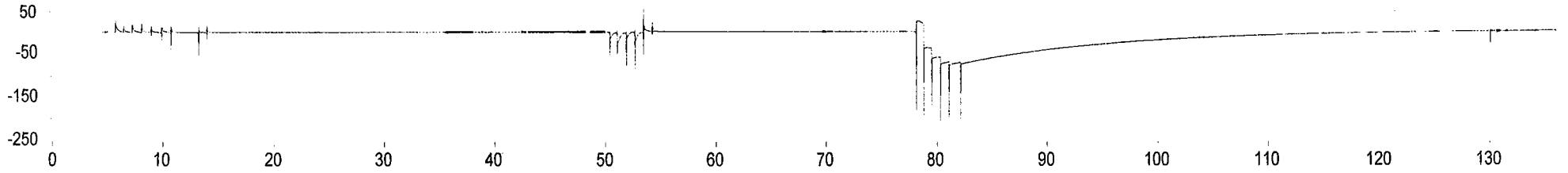
ABT.3.CH17_LBOXLAT



ABT.5.CH18_LBOXVERT

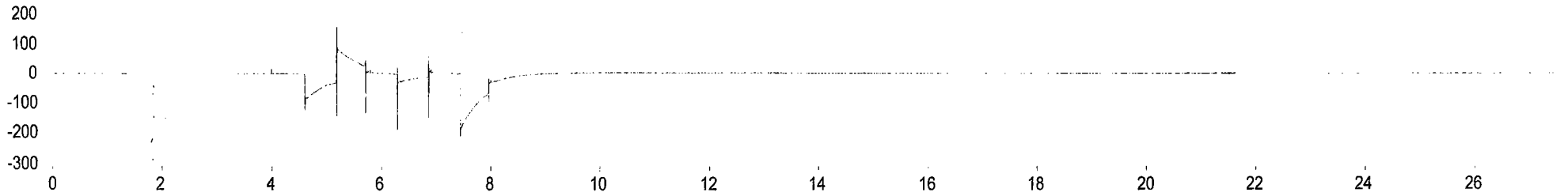

ABT.6.CH19_RBOXLAT

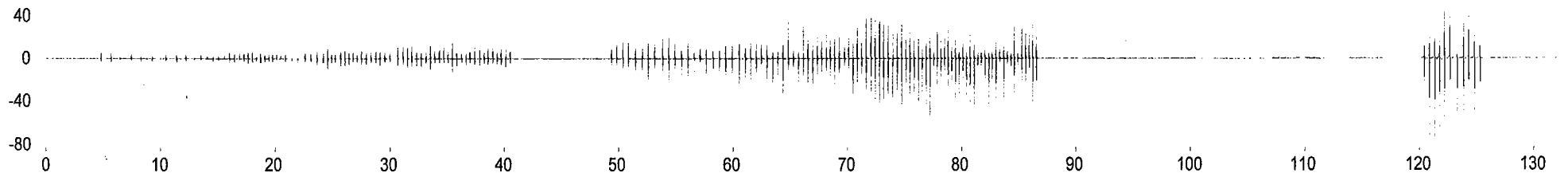

ABT.6.CH20_RBOXVERT

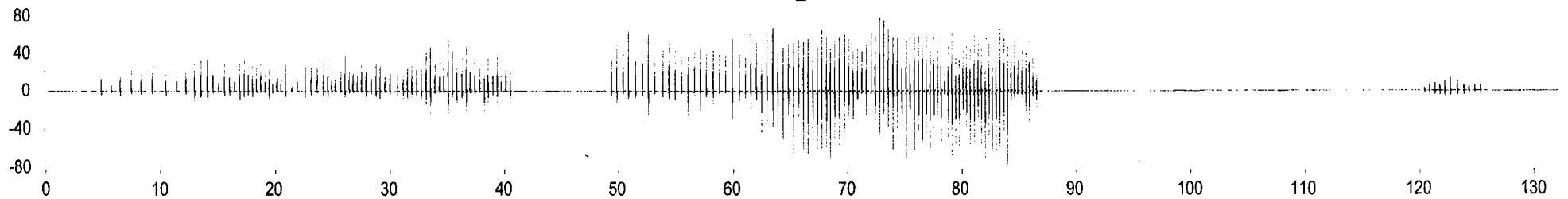

ABT.4.CH17_LBOXLAT

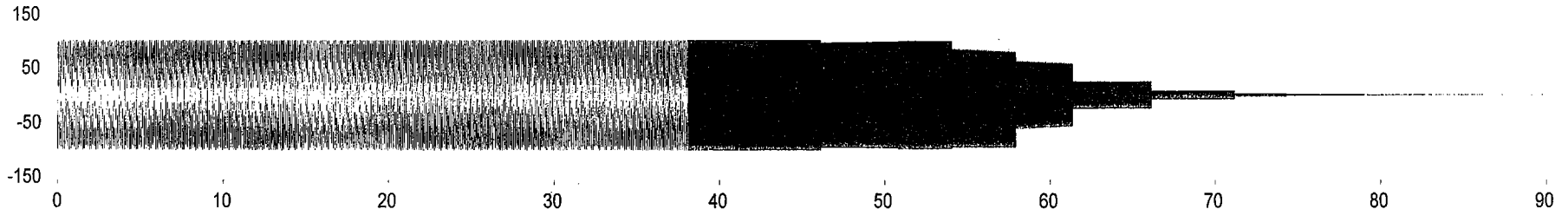

spectrum(LBOXLAT)

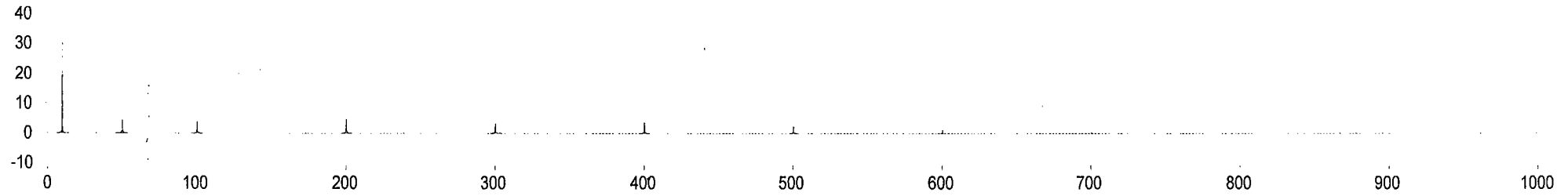

ABT.4.CH18_LBOXVERT

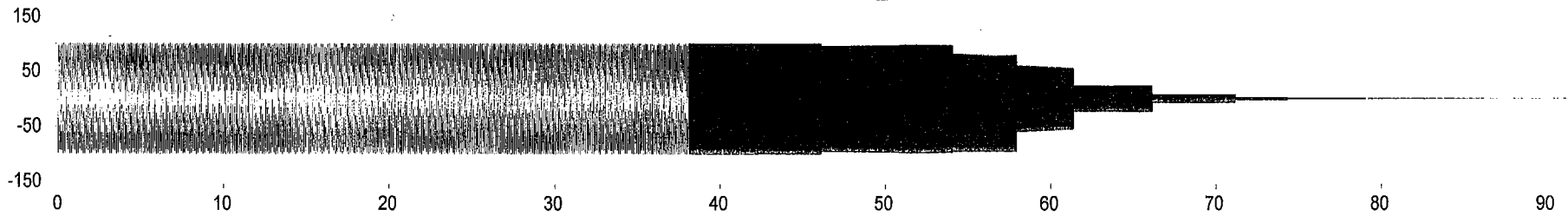

spectrum(LBOXVERT)

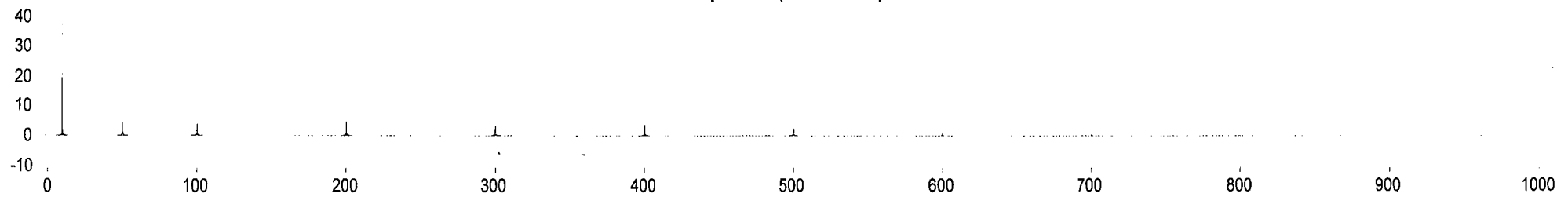

ABT.9.CH19_RBOXLAT

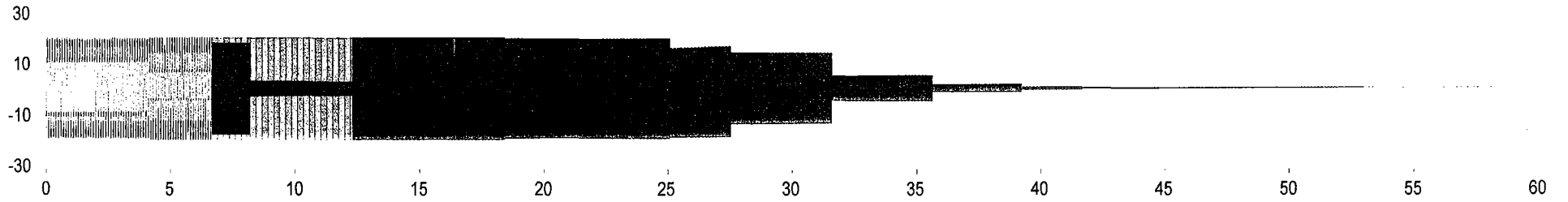

psd(w1)

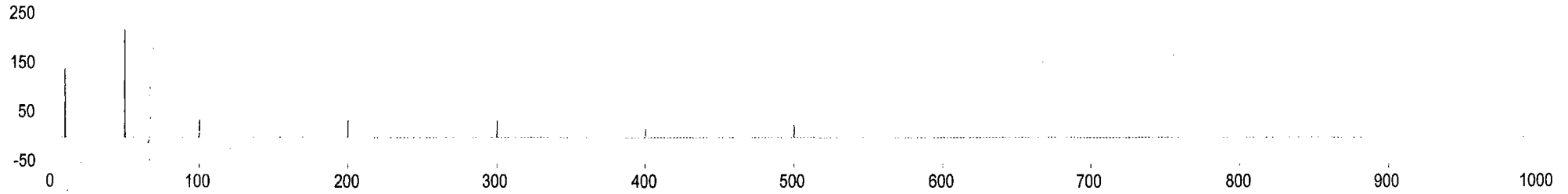

ABT.9.CH20_RBOXVERT

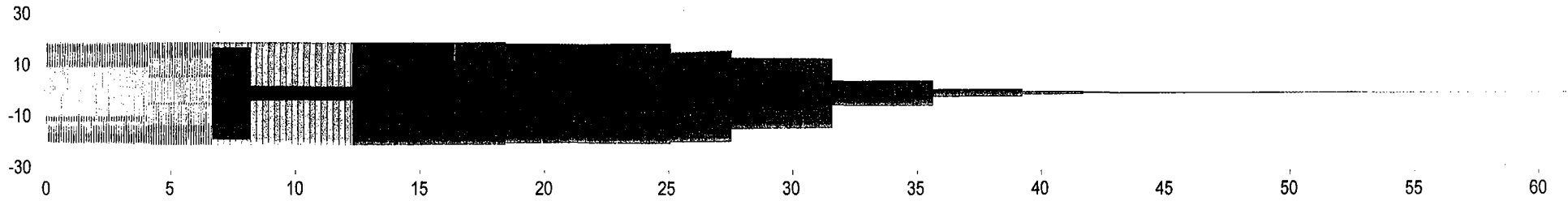

psd(w3)

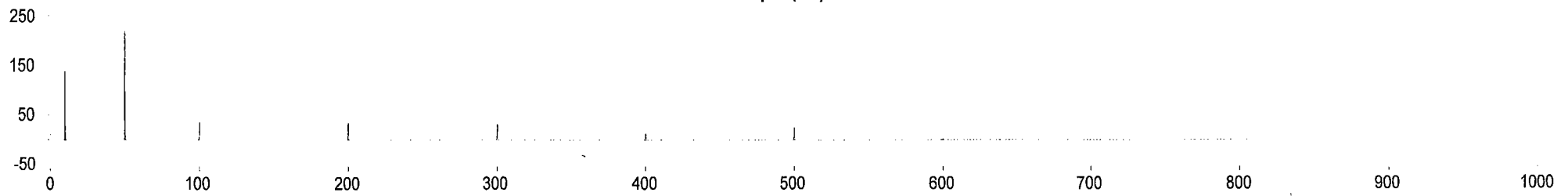

ABT.9.CH21_LatAccCenP

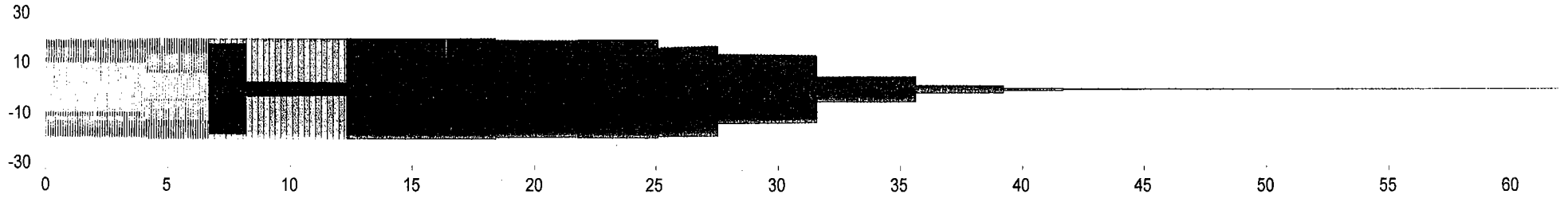

psd(w1)

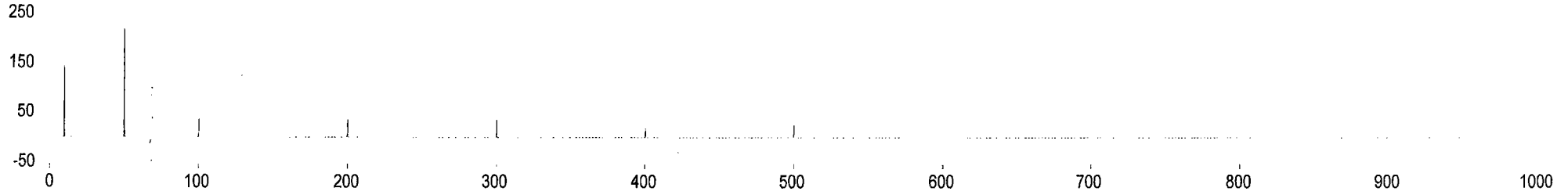

ABT.9.CH22_VertAccCen

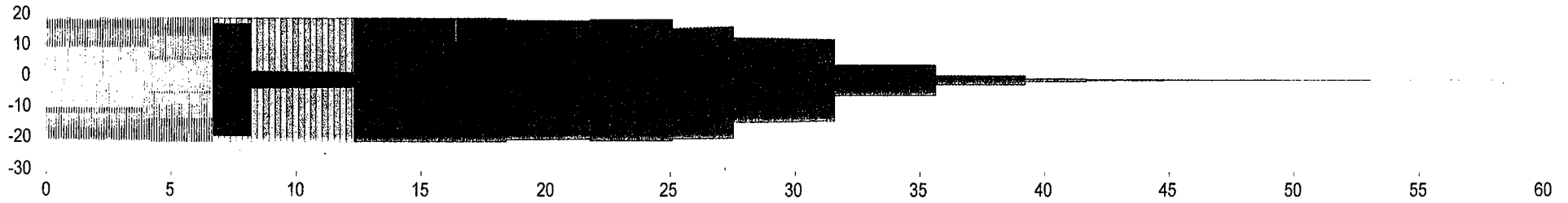

psd(w3)

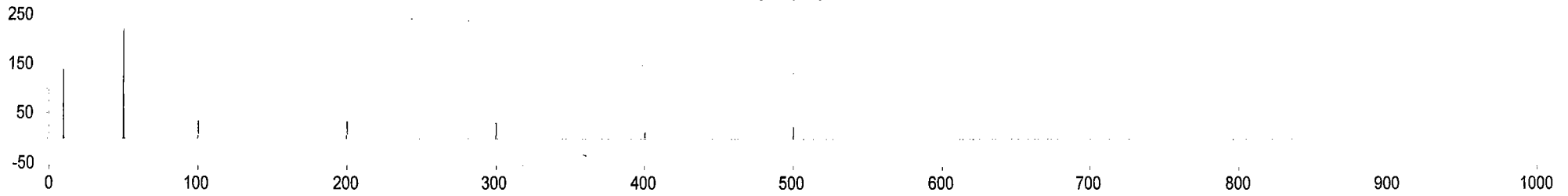

ABT.9.CH23_LonAccCenP

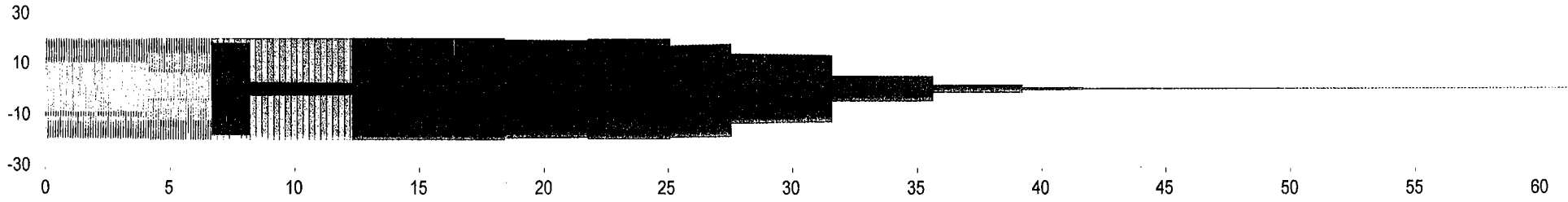

psd(w1)

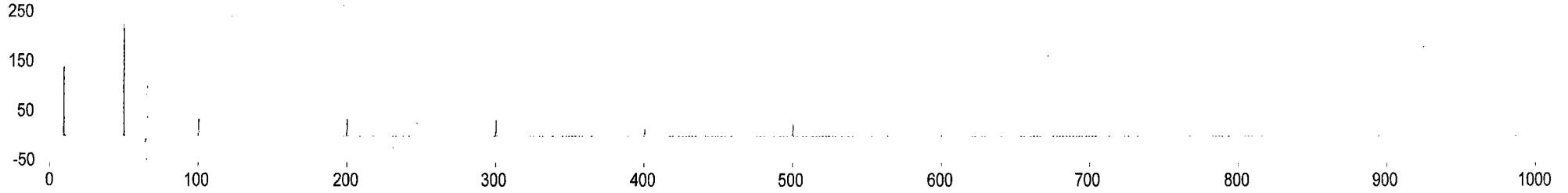

ABT.9.CH24_LatAccCenA

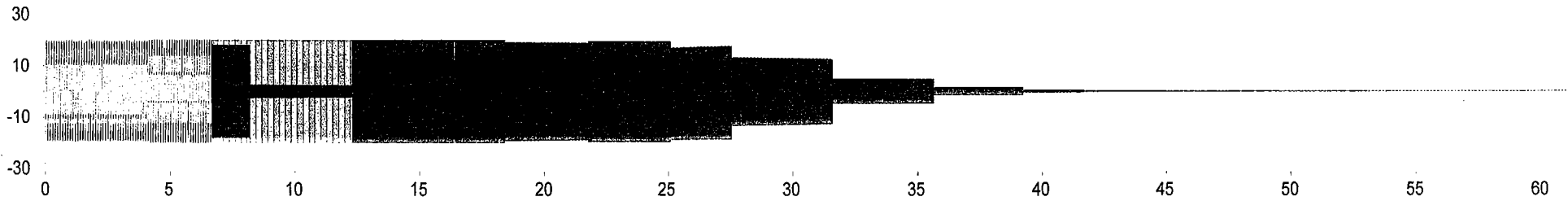

psd(w3)

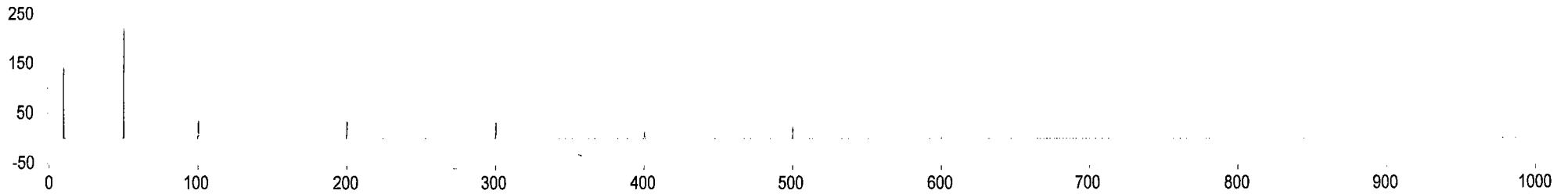

ABT.9.CH25_VertAccCen

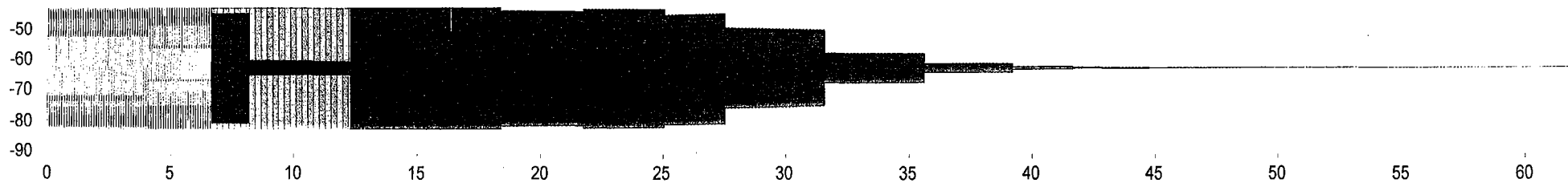

psd(demean(w1))

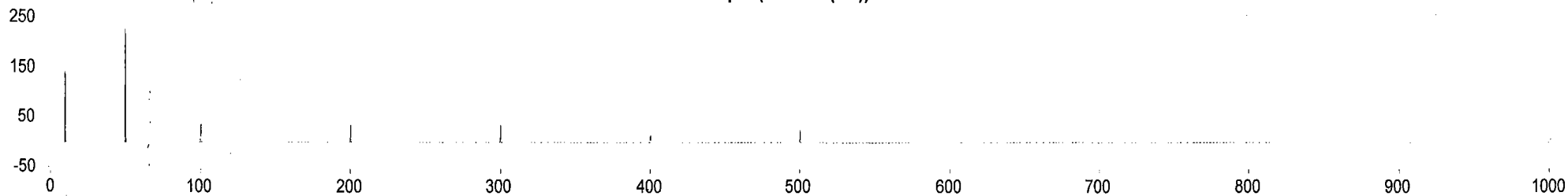

ABT.9.CH26_LonAccCenA

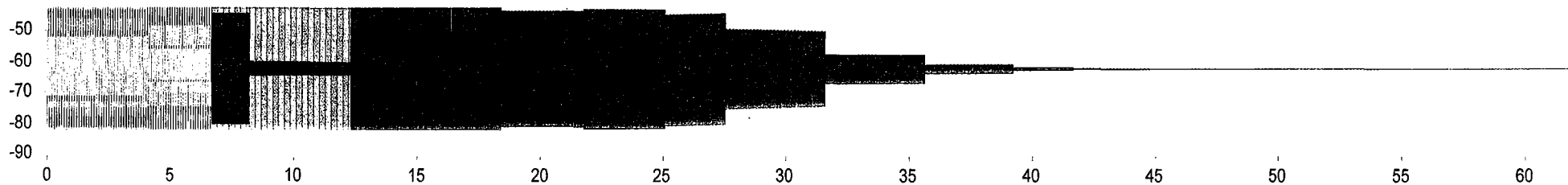

psd(demean(w3))

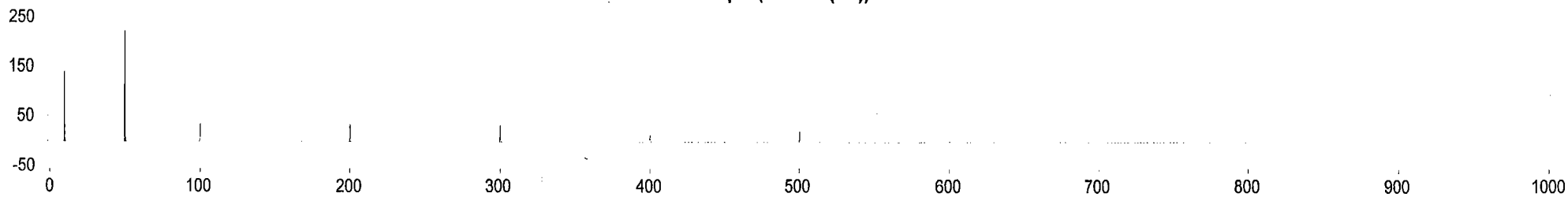

ABT.9.CH27_LatAccOutP

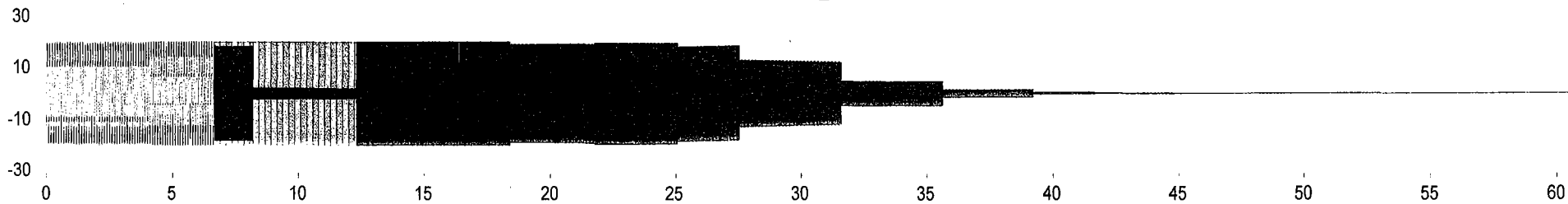

psd(w1)

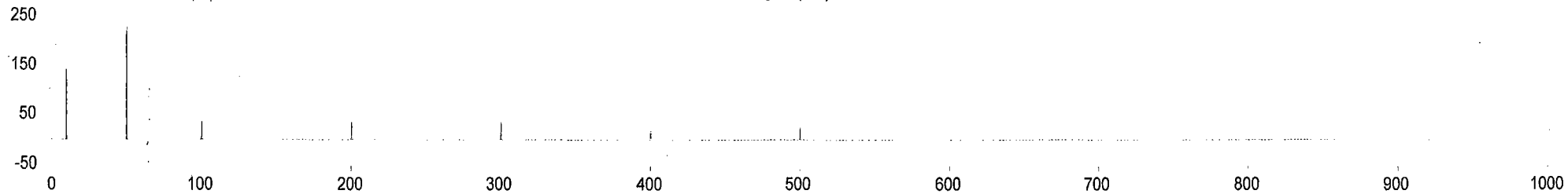

ABT.9.CH28_VertAccOut

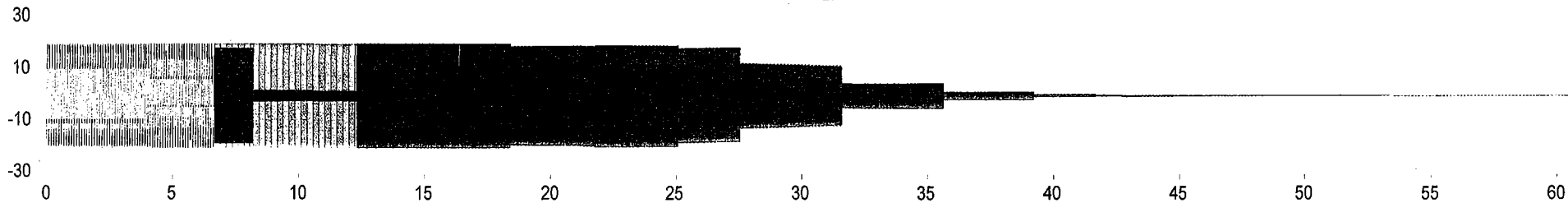

psd(w3)

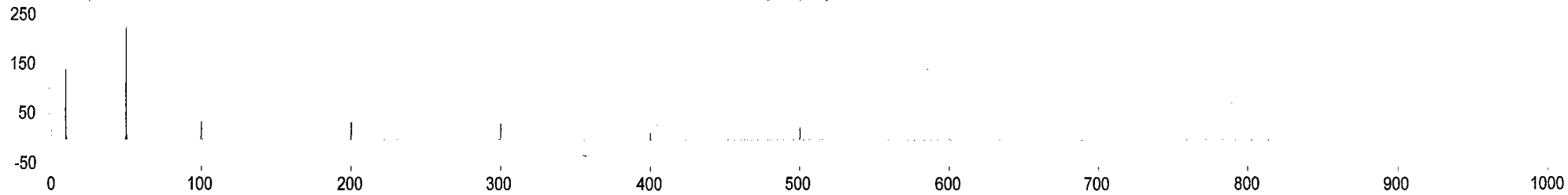

ABT.9.CH29_LonAccOutP

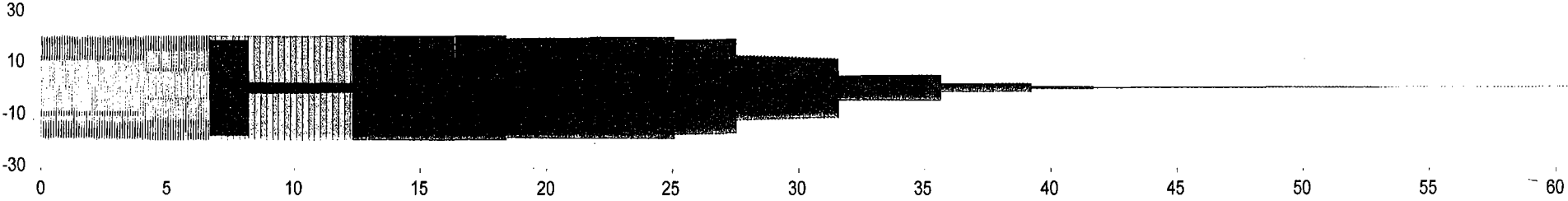

psd(w1)

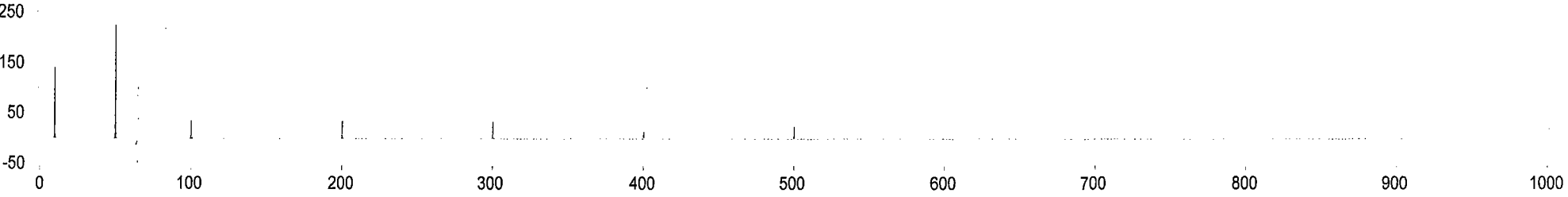

50Hz, 5g input

6

4

2

0

-2

-4

-6

111.75

111.80

111.85

111.90

111.95

112.00

112.05

112.10

112.15

112.20

112.25

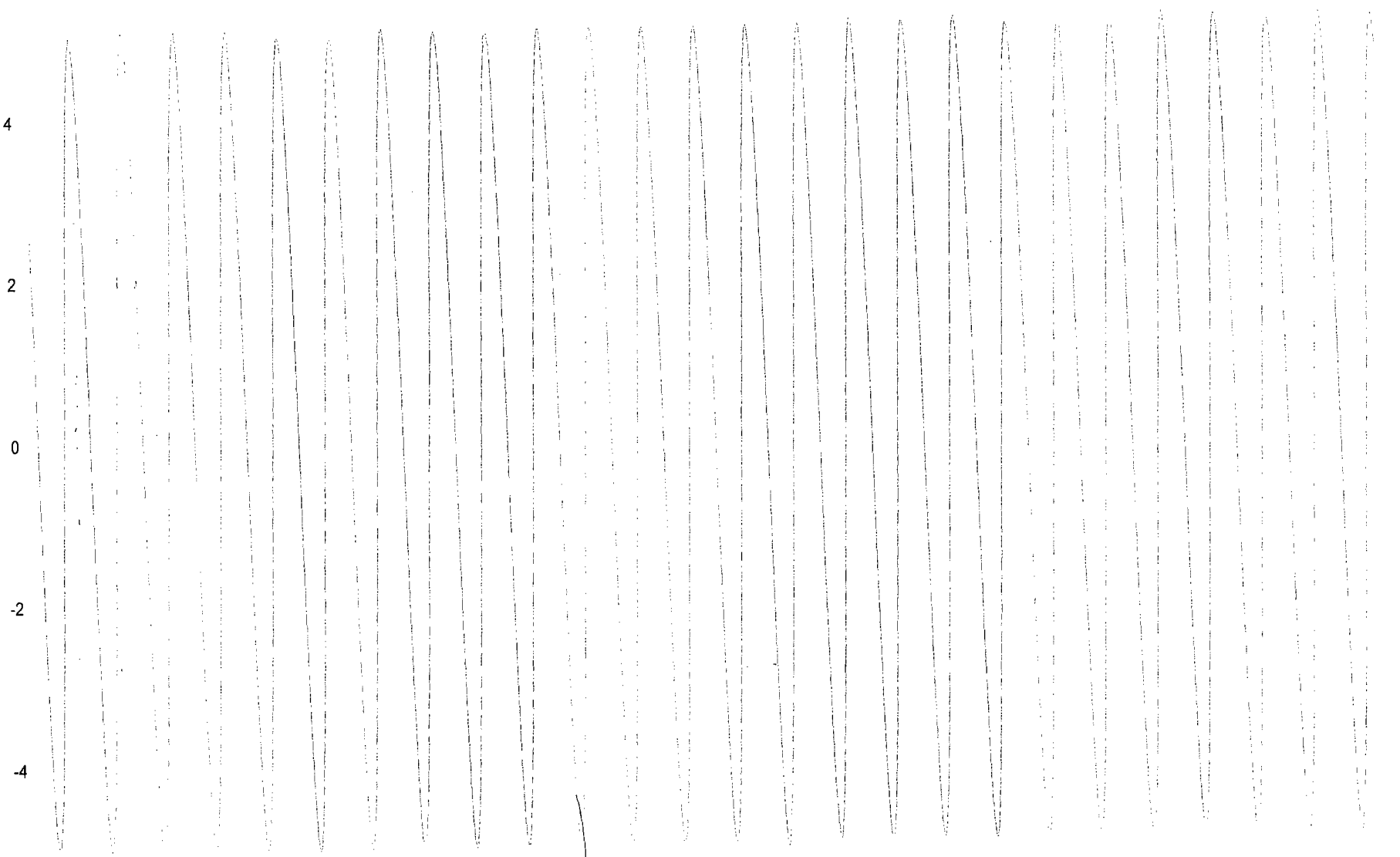

spectrum of 50Hz, 5g input



B-63

100 Hz, 10g input

15

10

5

0

-5

-10

-15

227.88

227.90

227.92

227.94

227.96

227.98

228.00

228.02

228.04

228.06

228.08

228.10

228.12

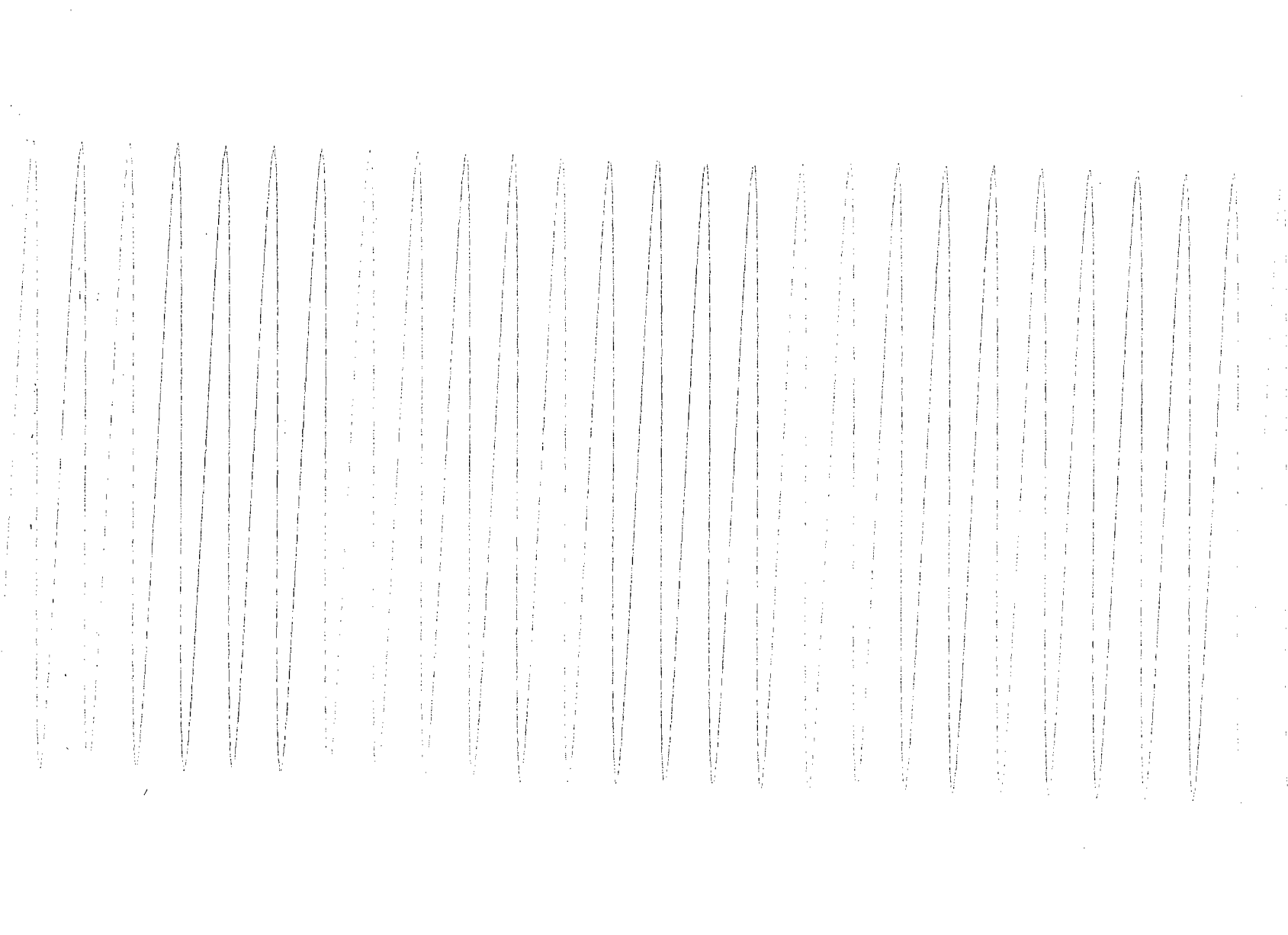

spectrum of 100Hz, 10g input

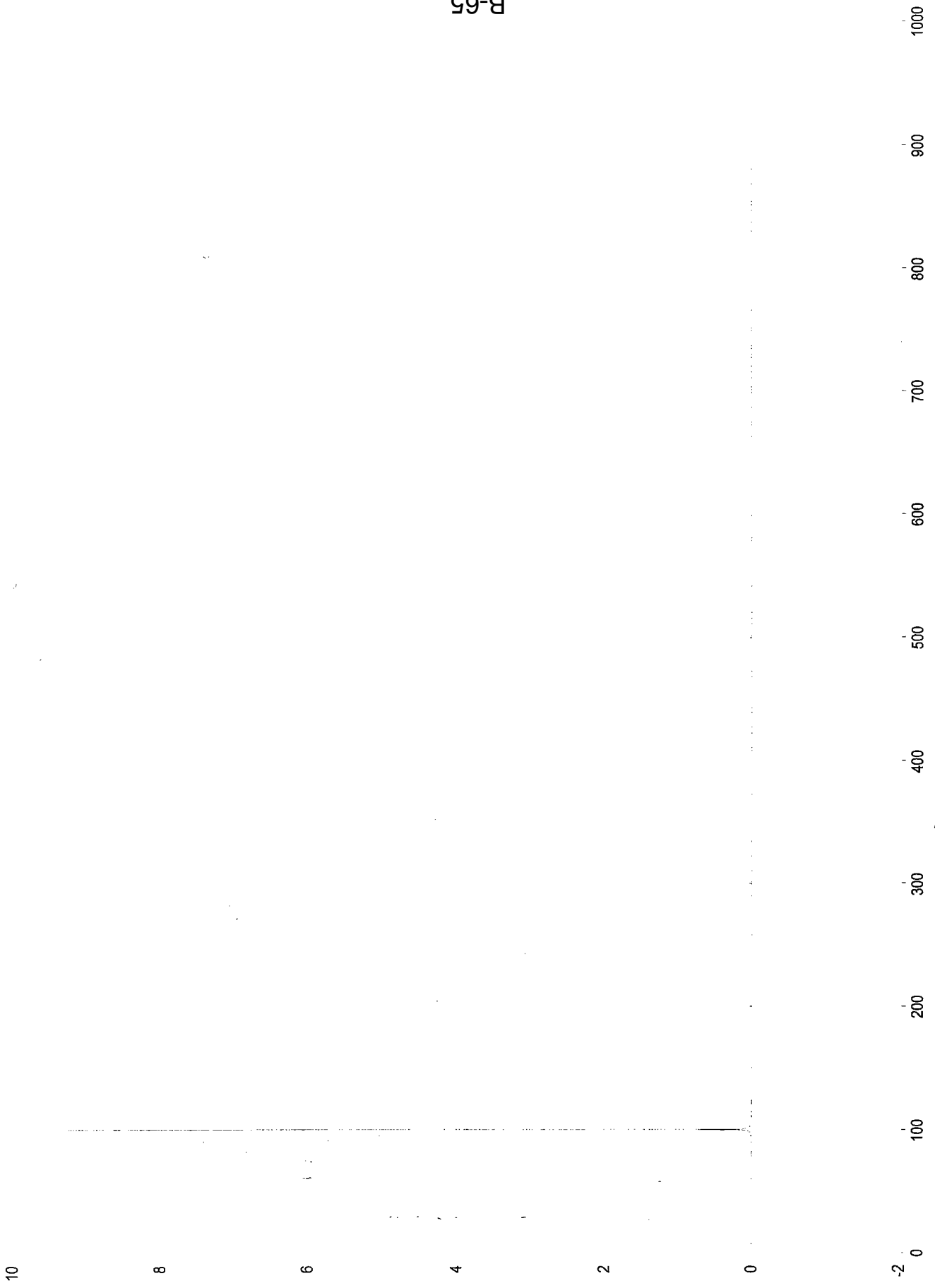

B-65

200Hz, 10g input

15

10

5

0

-5

-10

-15

309.930

309.940

309.950

309.960

309.970

309.980

309.990

310.000

310.010

310.020

310.030

310.040

310.050

310.060

310.070

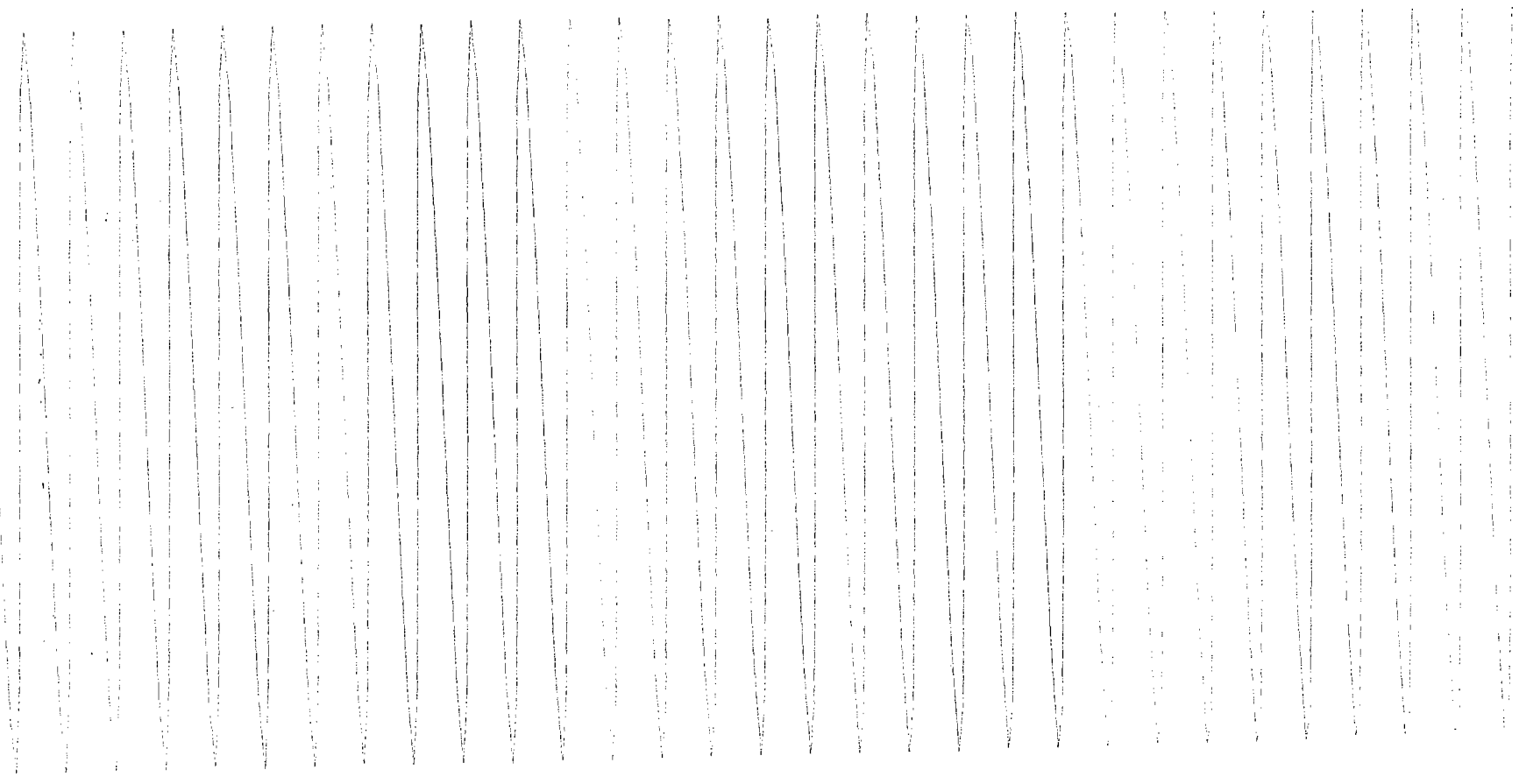

spectrum of 200Hz, 10g input



B-67

500Hz, 10g input

B-68

10

5

0

-5

-10

389.950

389.960

389.970

389.980

389.990

390.000

390.010

390.020

390.030

390.040

390.050

spectrum of 500Hz, 10g input

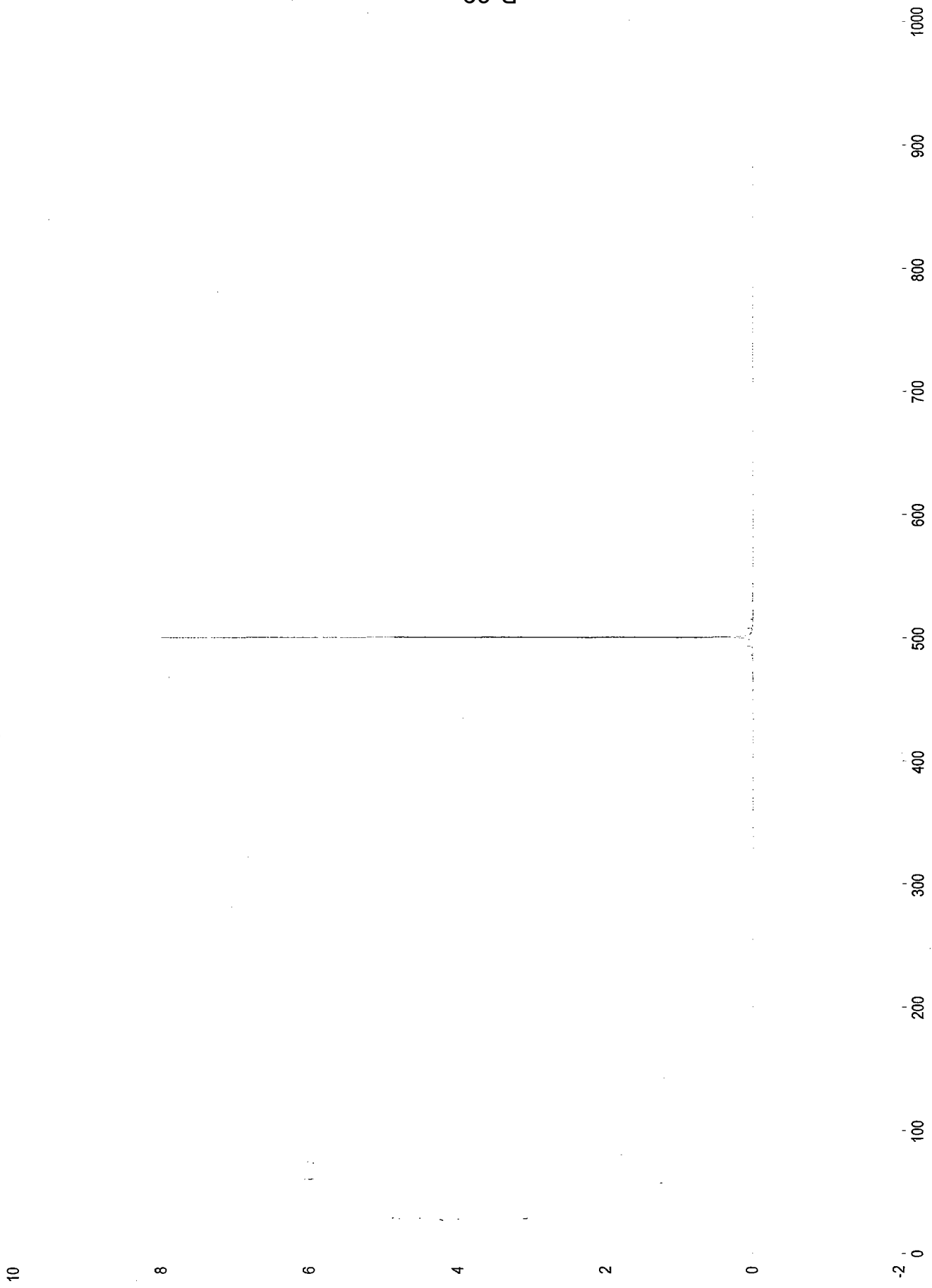

ABT.2.CH17_LBOXLAT

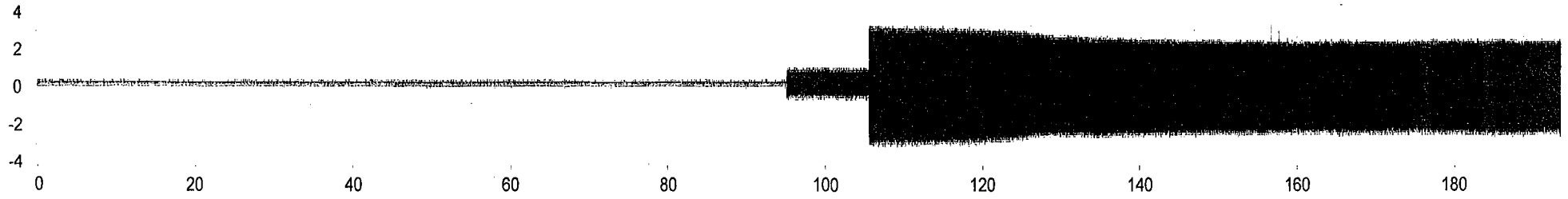

ABT.2.CH18_LBOXVERT

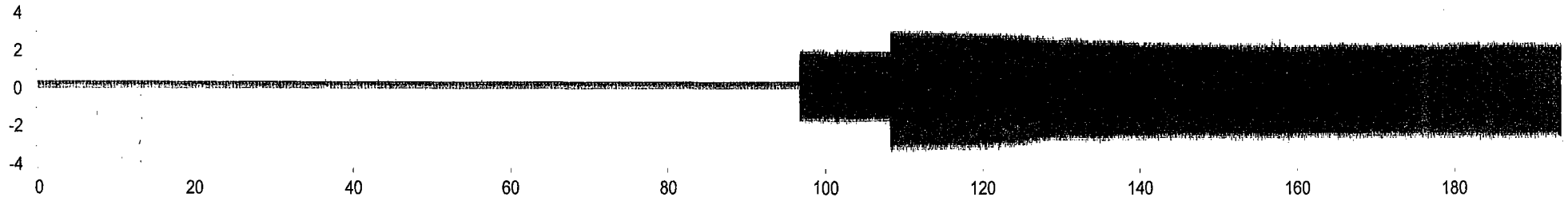

ABT.2.CH19_RBOXLAT

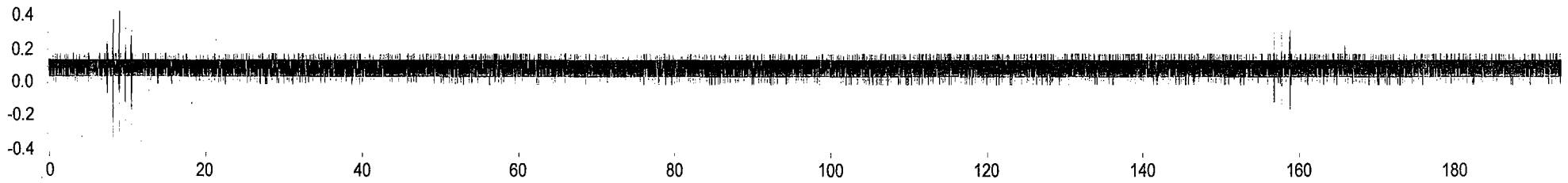

ABT.2.CH20_RBOXVERT

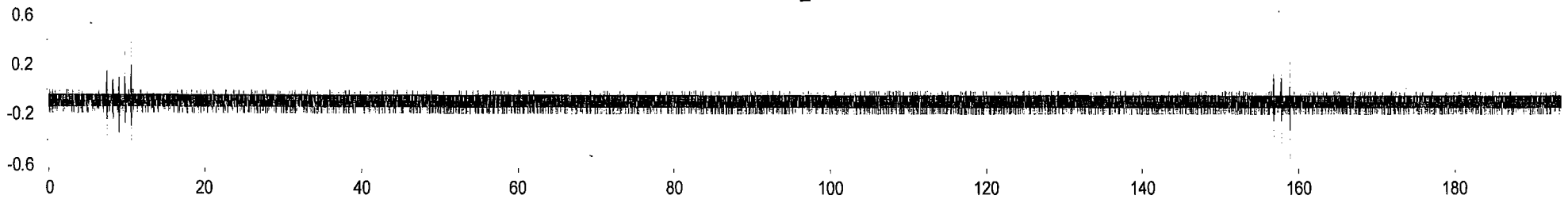

spectrum(LBOXLAT)

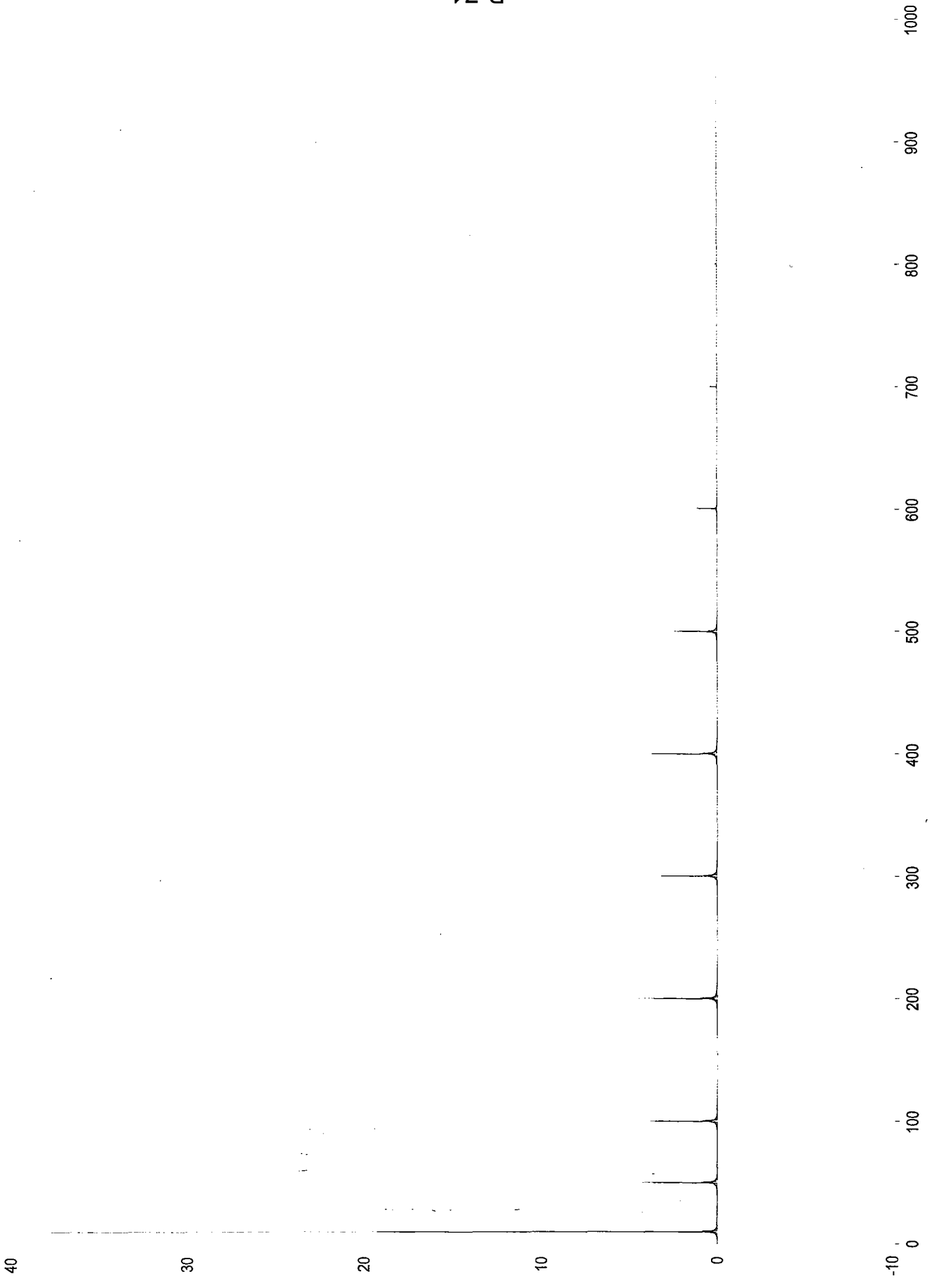

B-71

spectrum(LBOXVERT)

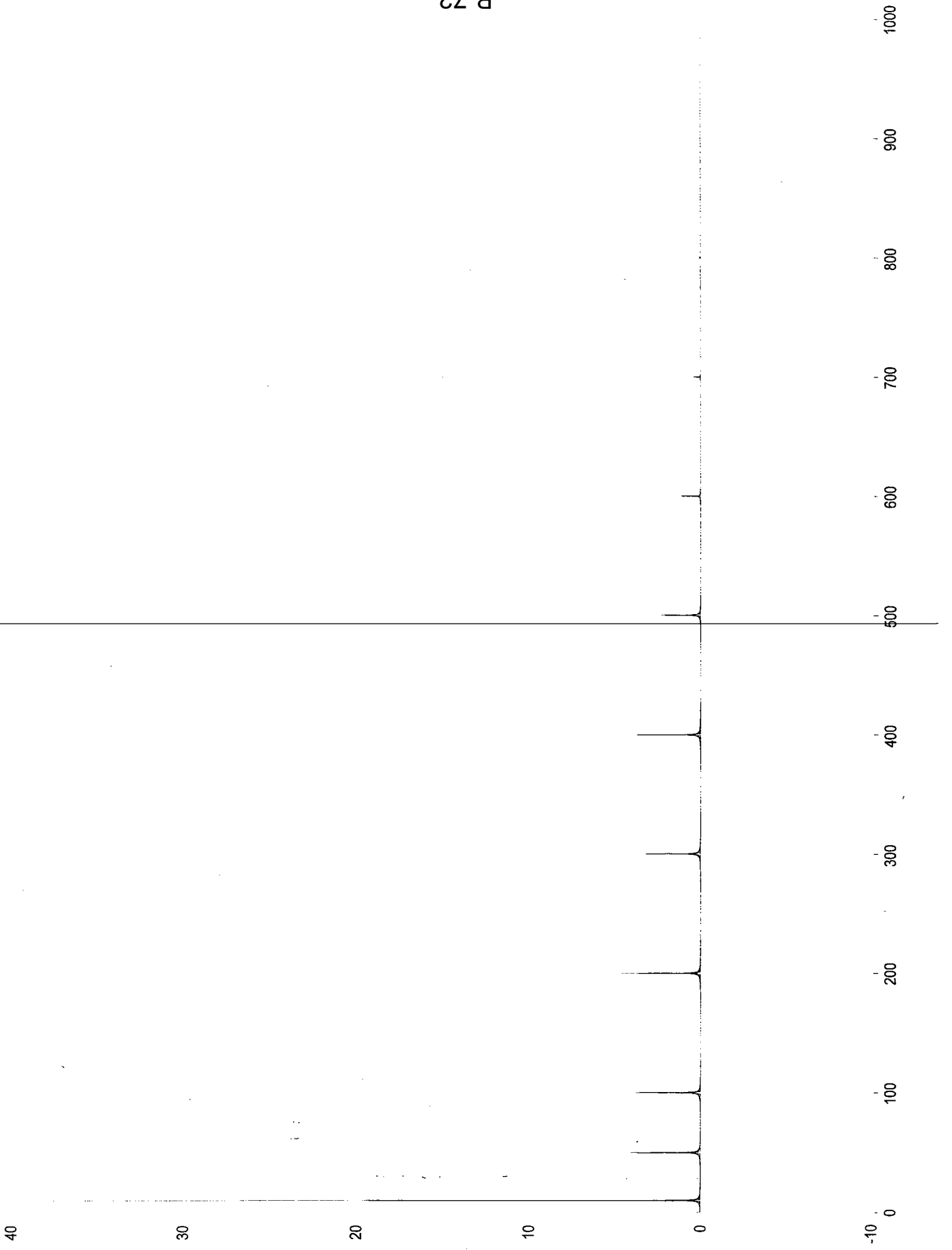

B-72

W1: 200 g Accelerometer with 100HZ Excitation

5115105
Accel Mounted on Ax6
Excited @ 100Hz
~10g amplitude

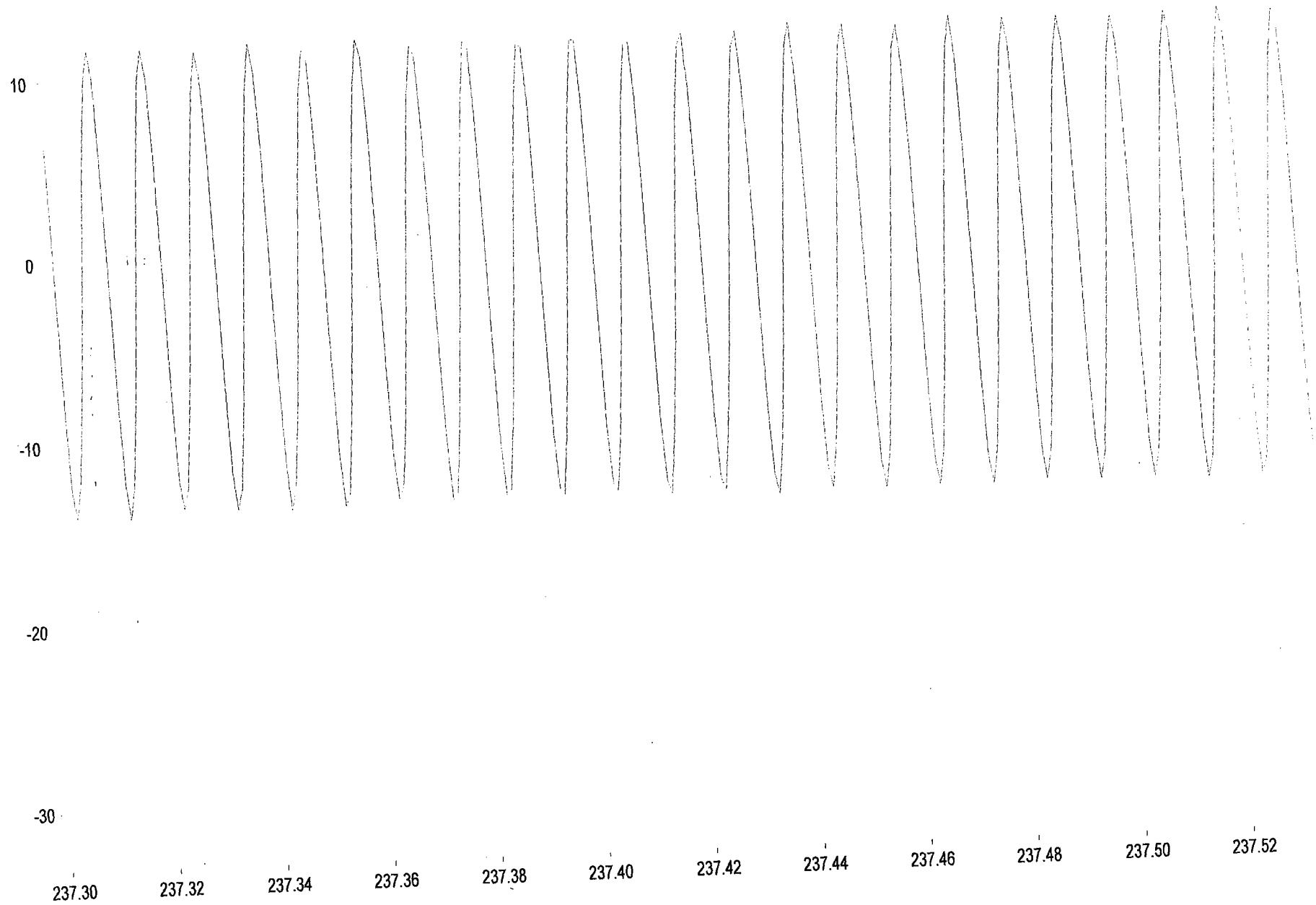

W2: Accelerometer Response(without filter)

5/15/05
Accel Mounted on axle
Frequency 100Hz ± 300Hz
Ampsl ≈ 10g peak-

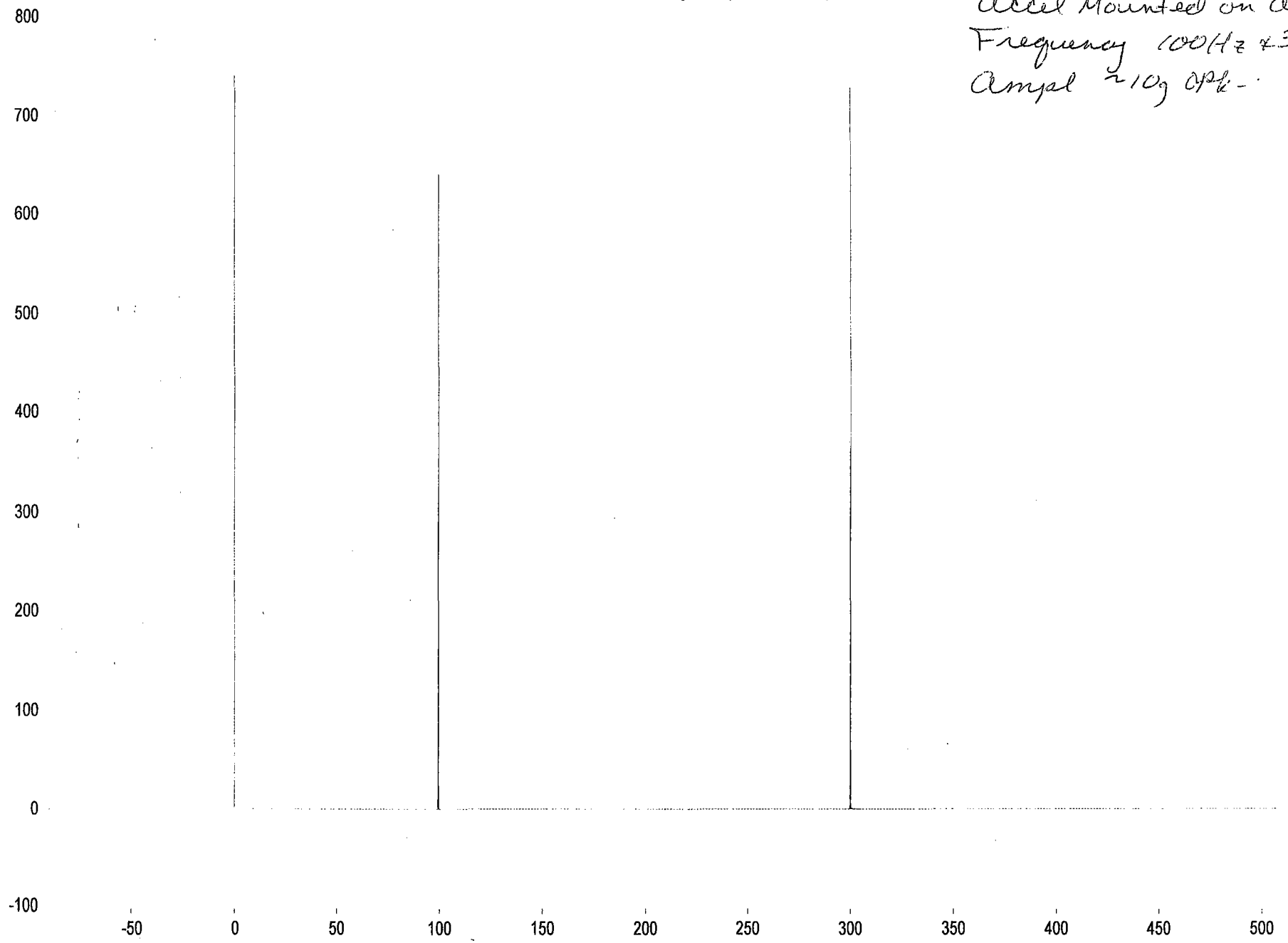

ABT.4.CH17_LBOXLAT

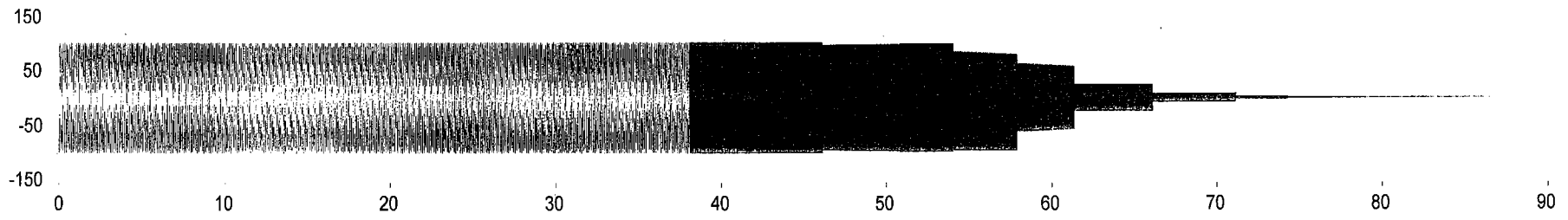

spectrum(w1)

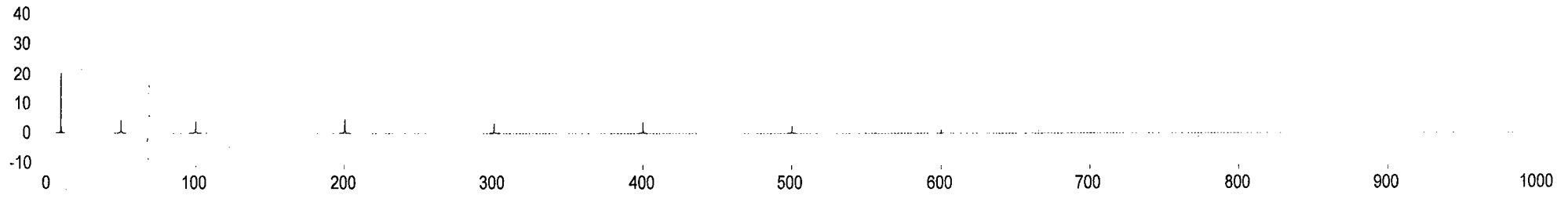

ABT.4.CH18_LBOXVERT

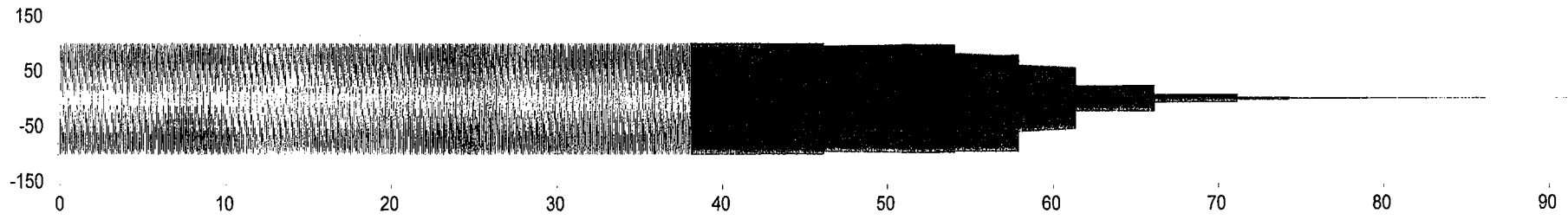

spectrum(w3)

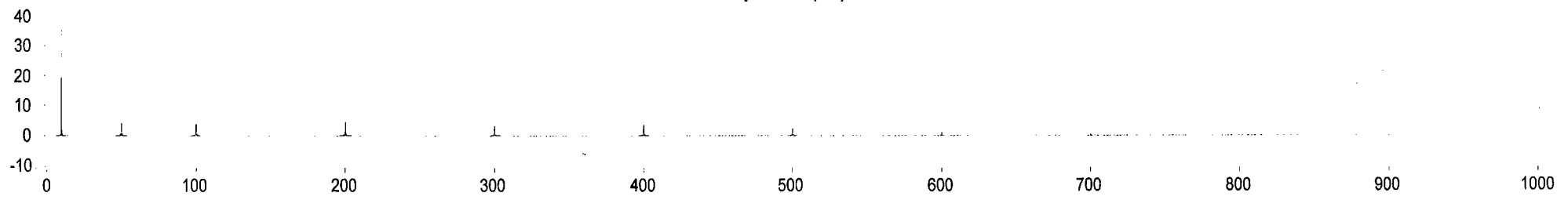

spectrum(w3)

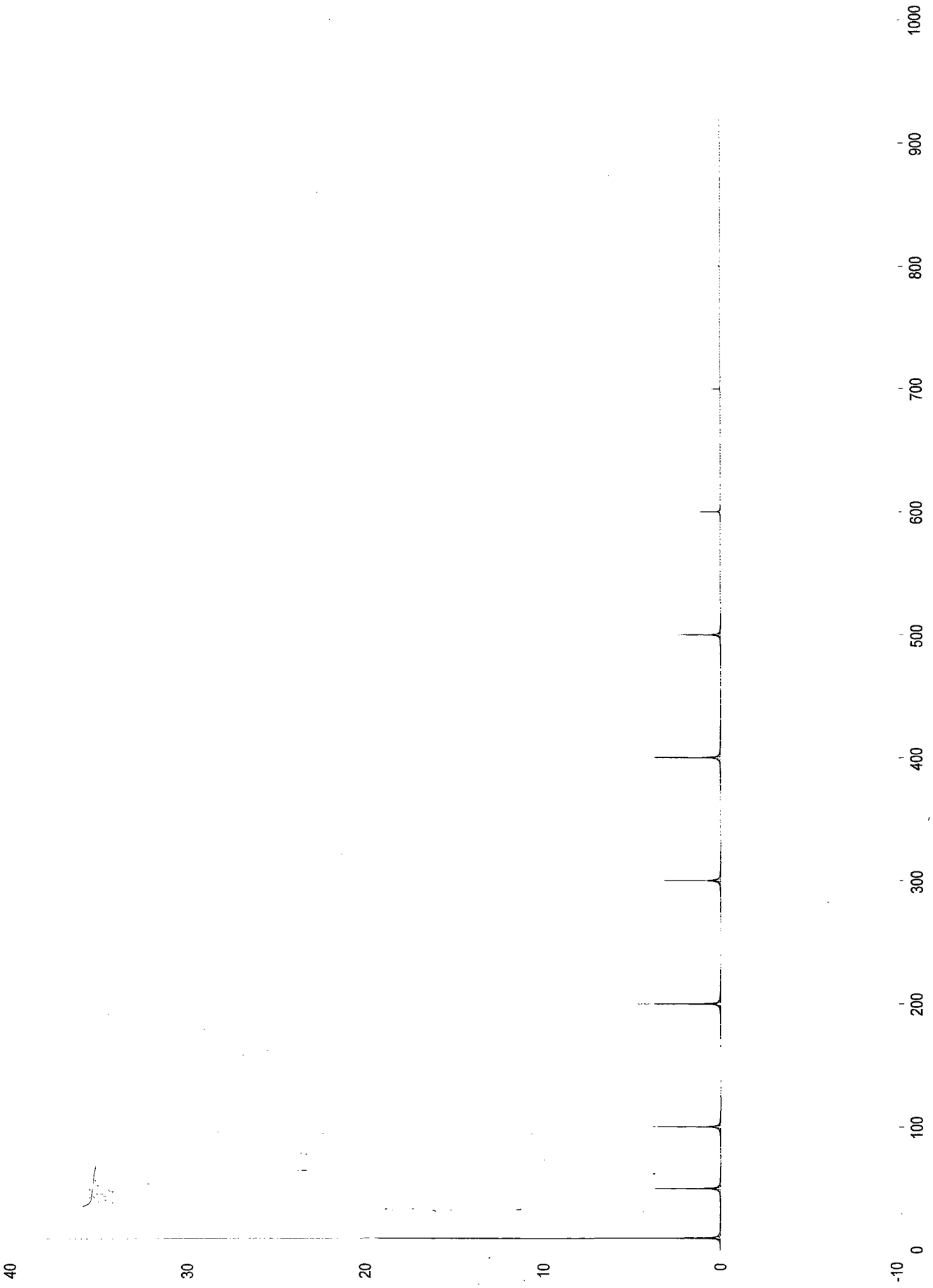

B-76

Appendix C. Data Descriptions

Data Acquisition FILE FORMAT–Acela Brake Test–May 9, 2005

During each data acquisition run, 3 files are generated.

1) Principal Data File, xxxxxxxx.abt

Binary Integer File, containing:

- a) Header record, 2 integers (4 bytes, 2 bytes/integer), followed by
- b) Sequential records of integer data, 32 integers/record (2 bytes/integer, 64 bytes/record)
 - Record 2: 32 integers (64 bytes); channels 1 - 32, at time t=0 seconds
 - Record 3: 32 integers (64 bytes); channels 1 - 32, at time t=1/1200th seconds
 - Record 4: 32 integers (64 bytes); channels 1 - 32, at time t=2/1200th seconds
 - ... etc.

Nominal Sampling Rate = 1200 samples/second
 Nominal Time between Samples = 0.00083 seconds

PRINCIPAL DATA FILE HEADER RECORD - 4 bytes total					
Byte Nos	Type	Parameter	Units	Nominal Value	No of Bytes
1 - 2	1 integer	no of columns (channels) per data record		32	2
3 - 4	1 integer	sample rate	samples/s	1200	2
Total					4

PRINCIPAL DATA FILE RECORD - 32 integers (64 bytes)				
Chan	Parameter	File Scale Factor [actuals in .Cal file]	Units	File Offset [actuals in .Cal file]
1	Strain gage, center rotor spoke	1	uE	0
2	Strain gage, center rotor spoke	1	uE	0
3	Strain gage, center rotor spoke	1	uE	0
4	Strain gage, center rotor spoke	1	uE	0
5	Strain gage, outer rotor spoke	1	uE	0
6	Strain gage, outer rotor spoke	1	uE	0
7	Strain gage, outer rotor spoke	1	uE	0
8	Strain gage, outer rotor spoke	1	uE	0
9	Thermocouple, center rotor spoke	10	F	0

10	Temperature, braking surface, infra-red, center rotor	10	F	0
11	Temperature, braking surface, infra-red, center rotor	10	F	0
12	Temperature, braking surface, infra-red, outer rotor	10	F	0
13	Temperature, braking surface, infra-red, outer rotor	10	F	0
14	Speed sine wave from resolver	1000		0
15	Speed from resolver	100	g	0
16	Lateral Acceleration, axle mounted near rotor	100	g	0
17	Lateral Acceleration, Axle Box left	100	g	0
18	Vertical Acceleration, Axle Box left	100	g	0
19	Lateral Acceleration, Axle Box right	100	g	0
20	Vertical Acceleration, Axle Box right	100	g	0
21	Lateral Acceleration, center caliper near pad	100	g	0
22	Vertical Acceleration, center caliper near pad	100	g	0
23	Longitudinal Acceleration, center caliper, near pad	100	g	0
24	Lateral Acceleration, center caliper, near actuator	100	g	0
25	Vertical Acceleration, center caliper, near actuator	100	g	0
26	Longitudinal Acceleration, center caliper, near actuator	100	g	0
27	Lateral Acceleration, outer caliper, near pad	100	g	0
28	Vertical Acceleration, outer caliper, near pad	100	g	0
29	Longitudinal Acceleration, outer caliper, near pad	100	g	0
30	Brake Pipe Pressure	100	psi	0
31	Brake Cylinder Pressure, center caliper	100	psi	0
32	Brake Park Pressure, center caliper	100	psi	0

2) GPS Data File, xxxxxxxx.gps

Ascii File, containing:

- a) Sequential records of data, Ascii format, 5 columns, space delimited, 41 characters/record (1 byte/character, 41 bytes/record)
 Record 1: 41 characters (41 bytes); gps data at time t=0 second
 Record 2: 41 characters (41 bytes); gps data at time t=1 second
 ... etc.

Sampling Rate = 1 sample/second

GPS Data File Format - Space Delimited			
Column	Parameter	Units	Nominal No. of Characters
1	GPS time, seconds past midnight Greenwich	sec	6
2	Latitude	deg	12
3	Longitude	deg	13
4	Speed	mph	6
5	No. of Satellites		4

3) Calibration File, xxxxxxxx.cal

Ascii File, containing:

- a) 1 record for each data channel (total of 32), Ascii format, 5 columns, space delimited
 Record 1: calibration data
 Record 2: 41 characters (41 bytes); gps data at time t=1 second

Column	Parameter	Units	Nominal No. of Characters
1	Sensor gain - required only for record	e.g. V/g	8
2	Sensor offset - required only for record	deg	8
3	File Scale Factor - necessary to convert file data to engineering units	deg	8
4	File Offset - necessary to convert file data to engineering units	mph	8
5	Channel description and units		~ 24

Note: Each integer stored in the .abt file must be divided by the respective file scale factor to obtain correct engineering units.

Data Acquisition FILE FORMATS–Acela Brake Test–May 24, 2005

During each data acquisition run, May 26 - 27, 2005, 4 files will be generated.

1) Principal Data File, 3000 Sampling Rate: xxxxxxxx.ab2

Binary Integer File, Intel format, integers in the range –32768 to +32768, containing:

- a) Header record, 2 integers (4 bytes, 2 bytes/integer), followed by
- b) Sequential records of integer data, 32 integers/record (2 bytes/integer, 64 bytes/record)
 - Record 2: 32 integers (64 bytes); channels 1 - 32, at time t=0 seconds
 - Record 3: 32 integers (64 bytes); channels 1 - 32, at time t=1/3000th seconds
 - Record 4: 32 integers (64 bytes); channels 1 - 32, at time t=2/3000th seconds
 - ... etc.

Nominal Sampling Rate = 3000 samples/second

Nominal Time between Samples = 0.00033 seconds

Principal Data File “.ab2” HEADER RECORD - 4 bytes total					
Byte Nos	Type	Parameter	Units	Nominal Value	No of Bytes
1 - 2	1 integer	no of columns (channels) per data record		32	2
3 - 4	1 integer	sample rate	samples/s	3000	2
Total					4

Principal Data File “.ab2” RECORD - 32 integers (64 bytes)				
Chan	Parameter	File Scale Factor [actuals in .Cal file]	Units	File Offset [actuals in .Cal file]
1	Strain gage, center disc spoke 6, F1	1	uE	0
2	Strain gage, center disc spoke 6, F2	1	uE	0
3	Strain gage, center disc spoke 6, R1	1	uE	0
4	Strain gage, center disc spoke 6, R2	1	uE	0
5	Strain gage, center disc spoke 3, R1	1	uE	0
6	Strain gage, center disc spoke 3, R2	1	uE	0
7	Strain gage, axle near center disc adjacent spoke 6	1	uE	0
8	Strain gage, axle near center disc adjacent spoke 3	1	uE	0
9	Strain gage, axle near ¼ location, adjacent spoke 6	1	uE	0
10	Strain gage, axle near ¼ location, adjacent spoke 3	1	uE	0
11	Thermocouple, back of friction ring	10	deg F	0
12	Temperature, braking surface, infra-red, center rotor	10	deg F	0
13	Temperature, braking surface, infra-red, center rotor	10	deg F	0

14	Sine wave from resolver	1000		0
15	Calculated speed from resolver	100	mph	0
16	Lateral Acceleration, axle mounted near rotor	100	g	0
17	Lateral Acceleration, Axle Box left	100	g	0
18	Vertical Acceleration, Axle Box left	100	g	0
19	Lateral Acceleration, Axle Box right	100	g	0
20	Vertical Acceleration, Axle Box right	100	g	0
21	Lateral Acceleration, center caliper near pad	100	g	0
22	Vertical Acceleration, center caliper near pad	100	g	0
23	Longitudinal Acceleration, center caliper, near pad	100	g	0
24	Lateral Acceleration, center caliper, near actuator	100	g	0
25	Vertical Acceleration, center caliper, near actuator	100	g	0
26	Longitudinal Accel, center caliper, near actuator	100	g	0
27	Lateral Acceleration, axle mounted (piezo-electric)	100	g	0
28	File Synchronization signal	1000	g	0
29	Lateral Acceleration, axle (strain-based)	100	g	0
30	Brake Pipe Pressure	100	psi	0
31	Brake Cylinder Pressure, center caliper	100	psi	0
32	Brake Park Pressure, center caliper	100	psi	0

Note: Each data integer stored in the .ab2 file must be divided by the respective file scale factor to obtain correct engineering units. i.e. Physical data value (engineering units) = integer / file scale factor - offset

2) GPS Data File: xxxxxxxx.gps

Ascii File, containing:

- a) Sequential records of data, Ascii format, 6 columns, space delimited, and trailing text giving location w.r.t. milepost, nominally 72 characters/record (1 byte/character, ~72 bytes/record)
 - Record 1: ~72 characters (41 bytes); gps data at time t=0 second
 - Record 2: ~72 characters (41 bytes); gps data at time t=1 second
 - ... etc.

Sampling Rate = 1 sample/second

GPS Data File Format - Space Delimited			
Column	Parameter	Units	Nominal No. of Characters
1	GPS time, seconds past midnight Greenwich	sec	6
2	Latitude	deg	12
3	Longitude	deg	13
4	Speed	mph	6
5	No. of Satellites		4
6	Corresponding time in the .AB2 data file	sec	6
7	Text giving location with respect to Milepost		25

3) Calibration File: xxxxxxxx.cal

Ascii File, containing:

- a) 1 record for each data channel (total of 32), Ascii format, 5 columns, space delimited

Column	Parameter	Units	Nominal No. of Characters
1	Sensor offset - required only for documentation	V	11
2	Sensor gain - required only for documentation	e.g. mV/g	11
3	File Scale Factor - necessary to convert file data to engineering units		8
4	File Offset - necessary to convert file data to engineering units		8
5	Channel description and units		~ 24

Note: Each data integer stored in the .ab2 file must be divided by the respective file scale factor to obtain correct engineering units. i.e. Physical data value (engineering units) = integer / file scale factor - offset

4) Data File, 10,000 Sampling Rate: xxxxxxxx.001

Binary Integer File, Motorola format, integers in the range -32768 to +32768, containing:

- a) Date record, 4 integers (8 bytes, 2 bytes/integer), followed by
- b) Sequential records of integer data, 16 integers/record (2 bytes/integer, 32 bytes/record)
 - Record 2: 16 integers (32 bytes); channels 1 - 16, at time t=0 seconds
 - Record 3: 16 integers (32 bytes); channels 1 - 16, at time t=1/10000th seconds
 - Record 4: 16 integers (32 bytes); channels 1 - 16, at time t=2/10000th seconds
 - ... etc.

Nominal Sampling Rate = 10000 samples/second

Nominal Time between Samples = 0.00010 seconds

Data File DATE RECORD - 8 bytes total					
Byte Nos	Type	Parameter	Units	Nominal Value	No of Bytes
1 - 2	1 integer	Date0			2
3 - 4	1 integer	Date1			2
5 - 6	1 integer	Date2			2
7 - 8	1 integer	Date3			2
Total					8

DATA FILE RECORD - 16 integers (32 bytes)				
Chan	Parameter	File Scale Factor	Units	File Offset
1	Vertical Acceleration, Axle Box Left	2.04800	g	0
2	Lateral Acceleration, Axle Box Left	2.04800	g	0
3	Vertical Acceleration, Axle Box Right	2.04800	g	0
4	Lateral Acceleration, Axle Box Right	2.04800	g	0
5	Lateral Acceleration, Axle (piezo-electric)	4.034560	g	0
6	Lateral Acceleration, Axle (strain-based)	2.06848	g	0
7	Strain gage, center rotor spoke 6, R1	0.1732267	uE	0
8	Strain gage, center rotor spoke 6, R2	0.1732267	uE	0
9	Strain gage, center rotor spoke 3, R1	0.1732267	uE	0
10	Strain gage, center rotor spoke 3, R2	0.1732267	uE	0
11	Strain gage, axle near center disc adjacent spoke 6	0.1732267	uE	0
12	Strain gage, axle near center disc adjacent spoke 3	0.1732267	uE	0
13	Strain gage, axle near ¼ location, adjacent spoke 6	0.1732267	uE	0
14	Strain gage, axle near ¼ location, adjacent spoke 3	0.1732267	uE	0
15	Sine wave from resolver	204.800	Volts	0
16	Synchronization pulses	204.800	Volts	0

Note: Each data integer stored in the .001 file must be divided by the respective file scale factor to obtain correct engineering units. i.e. Physical data value (engineering units) = integer / file scale factor - offset

CMSW32 Data Storage

CMSW32 stores test data in two files:

- *.CMW – Header File
- *.001 – Data File

Format of Header File (*.cmw)

Variable	Variable Type	No. of Bytes	Expected/ Default Values
Separator?	1 byte	1	
File Identifier	String [10]	10	'CMW32V2.1'
Separator?	1 byte	1	
Test Description	String [50]	50	
Separator?	1 byte	1	
Test Engineer	String [50]	50	
Separator?	1 byte	1	
Job Number	String [50]	50	
Separator?	1 byte	1	
Test Title	String [50]	50	'Acela Evaluation'
Number of Channels	Integer (4 byte)	4	16
Save Mode (for internal use)	Byte	1	
Total Bytes in Section 1		220	
Channel structure (x300 channels)			
Channel On	Boolean	1	
Separator?	1 byte	1	
Channel Description	String[30]	30	
Separator?	1 byte	1	
Channel Units	String[30]	30	
Volt Offset	Single (4 byte)	4	
Conversion Factor	Single (4 byte)	4	
Calibration Factor	Single (4 byte)	4	
High Alarm On	Boolean	1	
Low Alarm On	Boolean	1	
High Alarm Level	Single (4 byte)	4	
Low Alarm Level	Single (4 byte)	4	
High Alarm Dead band	Single (4 byte)	4	
Low Alarm Dead band	Single (4 byte)	4	
H Level Volts	Double (8 byte)	8	
L Level Volts	Double (8 byte)	8	
H Band Volts	Double (8 byte)	8	
L Band Volts	Double (8 byte)	8	
Gain	Byte	1	
Channel Colour	Integer (4 byte)	4	
Total Bytes for Each Channel (x 300 channels)		130	
Sample Rate	Double (8 byte)	8	0.0001
Voltage_Factor	Single (4 byte)	4	0.004883
Integer_Offset	Small Integer (2 byte)	2	2048

The data for each channel is calculated as:

$$\text{Volts} = \left[(\text{Bits} - \text{Integer_Offset}) \times \text{Voltage_Factor} - \text{Volt_Offset}_{\text{channel}} \right]$$

$$\text{Reading}_{\text{mechanical units}} = \text{Volts} * \text{Conversion_Factor}_{\text{channel}} - \text{CalibrationFactor}_{\text{channel}}$$

Data Acquisition FILE FORMATS–Acela Brake Test–June 15, 2005

During each data acquisition run, June 16 - 18, 2005, 3 files will be generated.

1) Principal Data File, 3000 Sampling Rate: xxxxxxxx.ab3

Binary Integer File, Intel format, integers in the range –32768 to +32768, containing:

- a) Header record, 2 integers (4 bytes, 2 bytes/integer), followed by
- b) Sequential records of integer data, 65 integers/record (2 bytes/integer, 130 bytes/record)
 - Record 2: 65 integers (130 bytes); channels 1 - 65 and speed, at time t=0 seconds
 - Record 3: 65 integers (130 bytes); channels 1 - 65 and speed, at time t=1/3000th seconds
 - Record 4: 65 integers (130 bytes); channels 1 - 65 and speed, at time t=2/3000th seconds
 - ... etc.

Nominal Sampling Rate = 3000 samples/second

Nominal Time between Samples = 0.00033 seconds

Principal Data File “.ab3” HEADER RECORD - 4 bytes total					
Byte Nos	Type	Parameter	Units	Nominal Value	No of Bytes
1 - 2	1 integer	no of columns (channels) per data record		65	2
3 - 4	1 integer	sample rate	samples/s	3000	2
Total					4

Principal Data File “.ab3” RECORD - 65 integers (130 bytes)					
Chan	Parameter	Axle	File Scale Factor [actuals in .Cal file]	Units	File Offset [actuals in .Cal file]
1	Lateral Acceleration, axle mounted	1	100	g	0
2	Lateral Acceleration, Truck Frame Left	1	100	g	0
3	Vertical Acceleration, Truck Frame Left	1	100	g	0
4	Longitudinal Acceleration, Truck Frame Left	1	100	g	0
5	Lateral Acceleration, Brake Mounting Tube	1	100	g	0
6	Vertical Acceleration, Brake Mounting Tube	1	100	g	0
7	Sine wave from resolver	1	1000		0
8	Sine wave from resolver	2	1000		0
9	Longitudinal Acceleration, Brake Mounting Tube	1	100	g	0
10	Lateral Acceleration, center caliper, near actuator	1	100	g	0
11	Vertical Acceleration, center caliper, near actuator	1	100	g	0
12	Longitudinal Accel, center caliper, near actuator	1	100	g	0
13	Brake Cylinder Pressure, center caliper	1	100	psi	0

14	Thermocouple, center rotor	1	10	deg F	0
15	File Synchronization signal		1000		0
16	Lateral Acceleration, axle mounted	2	100	g	0
17	Lateral Acceleration, Truck Frame Left	2	100	g	0
18	Vertical Acceleration, Truck Frame Left	2	100	g	0
19	Longitudinal Acceleration, Truck Frame Left	2	100	g	0
20	Lateral Acceleration, Brake Mounting Tube	2	100	g	0
21	Vertical Acceleration, Brake Mounting Tube	2	100	g	0
22	Longitudinal Acceleration, Brake Mounting Tube	2	100	g	0
23	Lateral Acceleration, center caliper, near actuator	2	100	g	0
24	Vertical Acceleration, center caliper, near actuator	2	100	g	0
25	Longitudinal Accel, center caliper, near actuator	2	100	g	0
26	Thermocouple, center rotor	2	10	deg F	0
27	Brake Cylinder Pressure, center caliper	2	100	psi	0
28	Strain gage, center disc spoke 6, F1	1	1	uE	0
29	Strain gage, center disc spoke 6, F2	1	1	uE	0
30	Strain gage, center disc spoke 6, R1	1	1	uE	0
31	Strain gage, center disc spoke 6, R2	1	1	uE	0
32	Bad channel, unused		1		0
33	Strain gage, center disc spoke 3, R1	1	1	uE	0
34	Strain gage, center disc spoke 3, R2	1	1	uE	0
35	Strain gage, axle near center disc adjacent spoke 6	1	1	uE	0
36	Strain gage, axle near center disc adjacent spoke 3	1	1	uE	0
37	Strain gage, axle near ¼ location, adjacent spoke 6	1	1	uE	0
38	Strain gage, axle near ¼ location, adjacent spoke 3	1	1	uE	0
39	Strain gage, center caliper left	1	1	uE	0
40	Strain gage, center caliper right	1	1	uE	0
41	Strain gage, center disc spoke 6, R1 (SG1)	2	1	uE	0

42	Strain gage, center disc spoke 6, R2 (SG2)	2	1	uE	0
43	Strain gage, center disc spoke 3, R1 (SG3)	2	1	uE	0
44	Strain gage, center disc spoke 3, R2 (SG3a)	2	1	uE	0
45	Strain gage, center disc spoke 6 face, upper gage (SG4)	2	1	uE	0
46	Strain gage, center disc spoke 6 face, lower gage (SG5)	2	1	uE	0
47	Strain gage, center disc spoke 4, R2 position (SG6)	2	1	uE	0
48	Strain gage, axle near center disc adjacent spoke 6	2	1	uE	0
49	Strain gage, axle near center disc adjacent spoke 3	2	1	uE	0
50	Strain gage, axle near ¼ location, adjacent spoke 6	2	1	uE	0
51	Strain gage, axle near ¼ location, adjacent spoke 3	2	1	uE	0
52	Strain gage, axle near center disc adjacent spoke 6 + 90°	2	1	uE	0
53	Strain gage, axle near center disc adjacent spoke 6 - 90°	2	1	uE	0
54	Lateral Acceleration, Axle Box left	1	100	g	0
55	Vertical Acceleration, Axle Box left	1	100	g	0
56	Lateral Acceleration, Axle Box right	1	100	g	0
57	Vertical Acceleration, Axle Box right	1	100	g	0
58	Lateral Acceleration, Axle Box left	2	100	g	0
59	Vertical Acceleration, Axle Box left	2	100	g	0
60	Lateral Acceleration, Axle Box right	2	100	g	0
61	Vertical Acceleration, Axle Box right	2	100	g	0
62	Lateral Acceleration 2, axle mounted	1	100	g	0
63	Lateral Acceleration 3, axle mounted	1	100	g	0
64	Longitudinal Acceleration, axle mounted	1	100	g	0
65	Calculated Speed for SINE 1		100	mph	0

Note: Each data integer stored in the .ab3 file must be divided by the respective file scale factor to obtain correct engineering units. i.e. Physical data value (engineering units) = integer / file scale factor - offset

2) GPS Data File: xxxxxxxx.gps

Ascii File, containing:

- a) Sequential records of data, Ascii format, 6 columns, space delimited, and trailing text giving location w.r.t. milepost, nominally 72 characters/record (1 byte/character, ~72 bytes/record)
 Record 1: ~72 characters (41 bytes); gps data at time t=0 second
 Record 2: ~72 characters (41 bytes); gps data at time t=1 second
 ... etc.

Sampling Rate = 1 sample/second

GPS Data File Format - Space Delimited			
Column	Parameter	Units	Nominal No. of Characters
1	GPS time, seconds past midnight Greenwich	sec	6
2	Latitude	deg	12
3	Longitude	deg	13
4	Speed	mph	6
5	No. of Satellites		4
6	Corresponding time in the .AB2 data file	sec	6
7	Text giving location with respect to Milepost		25

3) Calibration File: xxxxxxxx.cal

Ascii File, containing:

- a) 1 record for each data channel (total of 65), Ascii format, 5 columns, space delimited

Column	Parameter	Units	Nominal No. of Characters
1	Sensor offset - required only for documentation	V	11
2	Sensor gain - required only for documentation	e.g. mV/g	11
3	File Scale Factor - necessary to convert file data to engineering units		8
4	File Offset - necessary to convert file data to engineering units		8
5	Channel description and units		~ 24

Note: Each data integer stored in the .ab3 file must be divided by the respective file scale factor to obtain correct engineering units. i.e. Physical data value (engineering units) = integer / file scale factor - offset

Appendix D. Test Documents and Logs

Acela Brake Disc Test - Test Log

Date 14-May-05
 Test Run Shakedown Run
 Train Configuration Car 3413 on Trail End of Consist (PC 2038 Trailing)
 Sample Rate 1200 samples/sec
 Anti-Alias Filter Setting Set to 300 Hz

Filename	Start Location	End Location	Comments
051405_01.ABT	Ivy City	Ivy City	Prior to leaving, set spoke temperature by offset, zeroed strain gages.
051405_02.ABT	Ivy City	Ivy City	
051405_03.ABT	Ivy City	Washington Union Sta.	
051405_04.ABT	Washington Union Sta.	Washington Union Sta.	
051405_05.ABT	Washington Union Sta.	Baltimore	Vert/Lat Lbox failed; Temp OR R seems low 40deg, Temp CR L seems high 40 deg
051405_06.ABT	Baltimore	MP AP77	Applied Emergency Brake at end of file
051405_07.ABT	MP AP77	MP AP77	After Emergency Brake, checked temps with TC, hand pyrometer
051405_08.ABT	MP AP77	Wilmington, DE	Brake application at t=540; saturation of lateral accel on axle at t=1002; longitudinal looked off
Scale factors changed from 25mv/G to 50 mv/G on tri-axials on calipers			
051405_09.ABT	Wilmington, DE	Baltimore, MD	apply snow brake MP 27-MP 60, every disc, every pad @ 10psi; end of snow brake at Susq Br
051405_10.ABT	Baltimore, MD	Baltimore, MD	Sitting

CHANGED ACCELS IN BALTIMORE; BOTH ACCELS ON ENDS OF AXLES BAD

- Knorr Supplied 200G (L) and 500g (V) for Left Side Axle Box
- ENSCO put on 100 G tri-axial on right side axle box

051405_10.ABT	Baltimore, MD	Washington Union Sta.	Saw Noise on Left Axle End Accels (Lat & Vert) when slowing down, not while running
---------------	---------------	-----------------------	---

Acela Brake Disc Test - Test Log

Date 16-May-05
 Test Run Washington to Boston, 7-inch Cant Deficiency Run
 Train Configuration Car 3413 on Trail End of Consist (PC 2038 Trailing)
 Sample Rate 2000 samples/sec
 Anti-Alias Filter Settin Set to 500 Hz

Filename	Start Location	End Location	Channels	Header	Comments
systest16.ABT	NeC-MSC	NeC-MSC	sensors_VER8.xls	sample2000r1.hed	System Test in Shop - 2 Volts peak-to-peak, Fixed Frequency of 57 Hz
systest17.ABT	NeC-MSC	NeC-MSC	sensors_VER8.xls	sample2000r1.hed	System Test in Shop - Frequency Sweep
calfile1.ABT	NeC-MSC	NeC-MSC	sensors_VER8.xls	sample2000r1.hed	Zero All Accels/Gages
calfile2.ABT	NeC-MSC	NeC-MSC	sensors_VER8.xls	sample2000r1.hed	Shunted all Strain Gages
051605_01.ABT	Ivy City	Ivy City	sensors_VER8.xls	sample2000r1.hed	Yard Move
051605_02.ABT	Ivy City	Washington Union Sta.	sensors_VER8.xls	sample2000r1.hed	
051605_03.ABT	Washington Union Sta.	Baltimore MD (~MP AP 95)	sensors_VER8.xls	sample2000r1.hed	Pressures Dropped Out ~MP AP119
051605_04.ABT	Baltimore MD (~MP AP 95)	MP AP 85	sensors_VER8.xls	sample2000r1.hed	Full Service Brake Test at End so Temperature Meas. Could Be Made
051605_05.ABT	MP AP 85	~ MP AP 77	sensors_VER8.xls	sample2000r1.hed	System Lock-Up Ended Data Collection
051605_06.ABT	~ MP AP 77	MP AP 63	sensors_VER8.xls	sample2000r1.hed	Stopped Train to Close Open Door
051605_07.ABT	MP AP 63	Wilmington DE (MP AP 26)	sensors_VER8.xls	sample2000r1.hed	Noise on Left Axle Box Accels (Knorr); Same Signature on Both Lat and Vert
051605_08.ABT	Wilmington DE (MP AP 26)	Philadelphia, PA (MP AP 0)	sensors_VER8.xls	sample2000r1.hed	~MP AP 3 - Large Hit, Also Negative Spikes on Axle Lat Accel
051605_09.ABT	Philadelphia, PA (MP AP 0)	MP AN 60	sensors_VER8.xls	sample2000r1.hed	Full Service Brake Test at End, No Temperature Meas. Could Be Made
051605_10.ABT	MP AN 60	Newark, NJ (MP AN 8)	sensors_VER8.xls	sample2000r1.hed	At End of Run, Inserted Amtrak Lat and Vert Accels on Left End of Axle Box into Data Stream, Removed Knorr Accels from Data Collection; Lateral and Vertical Accels - +/- 250 G
051605_11.ABT	Newark, NJ (MP AN 8)	New York City (MP AN 0)	sensors_VER9.xls	sample2000r1.hed	Now Recording Amtrak Accels
051605_12.ABT	New York City (MP AN 0)	~ MP E 3	sensors_VER9.xls	sample2000r1.hed	Stopped Train to Fix Loose Tape on Axle
051605_13.ABT	~ MP E 3	MP E 19	sensors_VER9.xls	sample2000r1.hed	
051605_14.ABT	MP E 19	New Haven, CT (MP AB 73)	sensors_VER9.xls	sample2000r1.hed	Observed Periodic Signature From Time ~ 2100 - 2790; Observed Large Hit ~ MP MN 56
051605_15.ABT	New Haven, CT (MP AB 73)	~ MP AB 116	sensors_VER9.xls	sample2000r1.hed	Full Service Brake Test at End so Temperature Meas. Could Be Made
051605_16.ABT	~ MP AB 116	New London CT (MP AB 123)	sensors_VER9.xls	sample2000r1.hed	
051605_17.ABT	New London CT (MP AB 123)	~ MP AB 183	sensors_VER9.xls	sample2000r1.hed	Full Service Brake Test at End so Temperature Meas. Could Be Made
051605_18.ABT	~ MP AB 183	~ MP AB 185	sensors_VER9.xls	sample2000r1.hed	

Acela Brake Disc Test - Test Log

Date 16-May-05
 Test Run Washington to Boston, 7-inch Cant Deficiency Run
 Train Configuration Car 3413 on Trail End of Consist (PC 2038 Trailing)
 Sample Rate 2000 samples/sec
 Anti-Alias Filter Settin Set to 500 Hz

Filename	Start Location	End Location	Channels	Header	Comments
051605_19.ABT	~ MP AB 185	~ MP AB 200	sensors_VER9.xls	sample2000r1.hed	System Lock-Up During Full Service Brake Test to Take Temperature Meas.
051605_20.ABT	~ MP AB 202	~ MP AB 202	sensors_VER9.xls	sample2000r1.hed	Collected Data During Temperature Measurement
051605_21.ABT	~ MP AB 202	~ MP AB 212	sensors_VER9.xls	sample2000r1.hed	
051605_22.ABT	~ MP AB 212	~ MP AB 215	sensors_VER9.xls	sample2000r1.hed	
051605_23.ABT	~ MP AB 215	~ MP AB 219	sensors_VER9.xls	sample2000r1.hed	Full Service Brake Test at End so Temperature Meas. Could Be Made
051605_24.ABT	~ MP AB 219	Boston MA (MP AB 228)	sensors_VER9.xls	sample2000r1.hed	Saw Negative Spikes on Axle Mounted Accel ~MP AB 225

Acela Brake Disc Test - Test Log

Date 17-May-05
 Test Run Boston to Washington, 7-inch Cant Deficiency Run
 Train Configuration Car 3413 on Lead End of Consist (PC 2038 Leading)
 Sample Rate 2000 samples/sec (Changed in Baltimore to 4kHz, then to 3kHz)
 Anti-Alias Filter Setting Set to 500 Hz (Changed to 1kHz in Baltimore)

Filename	Start Location	End Location	Channels	Header	Comments
calfile051705_01.ABT	Maintenance Facility	Maintenance Facility	sensors_VER9.xls	sample2000r2.hed	Zero All Accels/Gages
calfile051705_02.ABT	Maintenance Facility	Maintenance Facility	sensors_VER9.xls	sample2000r2.hed	Shunted all Strain Gages
calfile051705_03.ABT	Maintenance Facility	Maintenance Facility	sensors_VER9.xls	sample2000r2.hed	Continuous Frequencies 100Hz, Ch 16, 19
calfile051705_04.ABT	Maintenance Facility	Maintenance Facility	sensors_VER9.xls	sample2000r2.hed	Sweep of Frequencies 100-1000 Hz, in Steps of 100 2 Volt P-P, Ch 16, 19
051705_01.ABT	Maintenance Facility	Boston MA (MP AB 228)	sensors_VER9.xls	sample2000r2.hed	
051705_02.ABT	Boston MA (MP AB 228)	Route 128 Station	sensors_VER9.xls	sample2000r2.hed	t=450 saturation on lat axle accel; no GPS
051705_03.ABT	Route 128 Station	?	sensors_VER9.xls	sample2000r2.hed	SYSTEM CRASH
051705_04.ABT	?	?	sensors_VER9.xls	sample2000r2.hed	SYSTEM RESTART, NO DATA
051705_05.ABT	?	?	sensors_VER9.xls	sample2000r2.hed	SYSTEM RESTART, NO DATA
051705_06.ABT	?	Providence RI	sensors_VER9.xls	sample2000r2.hed	t=522, noise spikes on strain gages, no GPS
051705_07.ABT	Providence RI	Westerley RI	sensors_VER9.xls	sample2000r2.hed	t=35, 340-360 spikes on Ctr Spoke F1 strain ENSCO system issue; no GPS
051705_08.ABT	Westerley RI	MP AB 127	sensors_VER9.xls	sample2000r2.hed	Stopped Train to Look at Lat Accel Axle; no GPS
051705_09.ABT	MP AB 127	MP AB 127	sensors_VER9.xls	sample2000r2.hed	Collecting Data During Troubleshooting, recover GPS
051705_10.ABT	MP AB 127	New London CT (MP AB 122)	sensors_VER9.xls	sample2000r2.hed	
051705_11.ABT	New London CT (MP AB 122)	MP AB 82	sensors_VER9.xls	sample2000r2.hed	
051705_12.ABT	MP AB 82	New Haven, CT (MP MN 72)	sensors_VER9.xls	sample2000r2.hed	
051705_13.ABT	New Haven, CT (MP MN 72)	MP MN 65	sensors_VER9.xls	sample2000r2.hed	
051705_14.ABT	MP MN 65	MP MN 57	sensors_VER9.xls	sample2000r2.hed	
051705_15.ABT	MP MN 57	MP MN 40	sensors_VER9.xls	sample2000r2.hed	
051705_16.ABT	MP MN 40	MP MN 19	sensors_VER9.xls	sample2000r2.hed	
051705_17.ABT	MP MN 19	New York City (MP AN 0)	sensors_VER9.xls	sample2000r2.hed	t=230,520 large strains on CTRSPOKE Rib 1 when brakes applied
051705_18.ABT	New York City (MP AN 0)	Newark NJ	sensors_VER9.xls	sample2000r2.hed	

Acela Brake Disc Test - Test Log

Date 17-May-05
 Test Run Boston to Washington, 7-inch Cant Deficiency Run
 Train Configuration Car 3413 on Lead End of Consist (PC 2038 Leading)
 Sample Rate 2000 samples/sec (Changed in Baltimore to 4kHz, then to 3kHz)
 Anti-Alias Filter Setting Set to 500 Hz (Changed to 1kHz in Baltimore)

Filename	Start Location	End Location	Channels	Header	Comments
051705_19.ABT	Newark NJ	Philadelphia, PA	sensors_VER9.xls	sample2000r2.hed	t=120, strains in CTRSPOKE ribs huge when braking not in face, audible braking noise; t=360, same thing not as high no audible brake noise; t=705 strain gage jump - SCU issue Large Hits at Midway; Full Service Brake Application t look at strains after Midway (no high strains); t~1585 brake applied, high CTRSPOKE Ribs strains t~1728,1785 and after - several examples of lat accel saturation.
051705_20.ABT	Philadelphia, PA	Wilmington DE (MP AP 26)	sensors_VER9.xls	sample2000r2.hed	t=1250 big strains CTRSPOKE ribs during braking
051705_21.ABT	Wilmington DE (MP AP 26)	Baltimore MD (MP AP 95)	sensors_VER9.xls	sample2000r2.hed	t=1220, 1476 big strains on CTRSPOKE ribs during braking; Saturation of lat axle accel at t=1310,1900,2210 t=2017, big strains during braking on CTRSPOKE, big strain spike follows; t~2200(MP 89) saturation of Lat Accel axle, left axle box lat, right axle box vert t=2410 big strains on CTRSPOKE ribs during braking starting to see same in OUTSPOKE as well
051705_22.ABT	Baltimore MD (MP AP 95)	Baltimore MD (MP AP 95)	sensors_VER9.xls		SWITCH SAMPLE RATE TO 4kHz, Anti-Alias @ 1kHz SYSTEM CRASH
051705_23.ABT	Baltimore MD (MP AP 95)	MP AP 110	sensors_VER9.xls	sample3000r2.hed	SWITCH SAMPLE RATE TO 3kHz, Anti-Alias @ 1kHz SYSTEM CRASH DUE TO COPYING FILES
051705_24.ABT	MP AP 110	Washington DC	sensors_VER9.xls	sample3000r2.hed	Sample Rate 3kHz, Anti-Alias @ 1kHz

Acela Brake Disc Test - Test Log

Date 26-May-05
 Test Run Washington to Boston, 7-inch Cant Deficiency Run
 Train Configuration Car 3413 on Lead End of Consist (PC 2038 Leading)
 Sample Rate 3000 samples/sec on ENSCO System, 10,000 Hz on Amtrak System
 Anti-Alias Filter Setting Set to 1000 Hz for ENSCO System Only; No Anti-Alias Filter Used on Amtrak System

3kHz (32 ch) System Filename (*ABT, *.CAL, *.GPS)		10kHz (16 ch) System Filename (*001)		Start Location	End Location	Track (if avail)	Channels	Header (3kHz)	Header (10kHz)	Comments
052605_0		NeC-MSC	NeC-MSC				sensors_VER13.xls	sample3000r5.hed	sample10000r3.hed	zeroes the gages and the accelerometers
052605_shunt		NeC-MSC	NeC-MSC				sensors_VER13.xls	sample3000r5.hed	sample10000r3.hed	System Test in Shop - Frequency Sweep
052605_sweep		NeC-MSC	NeC-MSC				sensors_VER13.xls	sample3000r5.hed	sample10000r3.hed	Chs. 1 & 17, 100 to 8K 5 secs 2V Pk-to-Pk sine wave
052605_freq		NeC-MSC	NeC-MSC				sensors_VER13.xls	sample3000r5.hed	sample10000r3.hed	
052605_zero2		NeC-MSC	NeC-MSC				sensors_VER13.xls	sample3000r5.hed	sample10000r3.hed	zeroing of center calliper actuator accelerometers
052605_sync		NeC-MSC	NeC-MSC				sensors_VER13.xls	sample3000r5.hed	sample10000r3.hed	sync test of the 2 systems
052605_shuntaxlat3		NeC-MSC	NeC-MSC				sensors_VER13.xls	sample3000r5.hed	sample10000r3.hed	to shunt calib the lat 3 accel
052605_sync2		NeC-MSC	NeC-MSC				sensors_VER13.xls	sample3000r5.hed	sample10000r3.hed	testing of the sync again
052605_sync3		NeC-MSC	NeC-MSC				sensors_VER13.xls	sample3000r5.hed	sample10000r3.hed	testing of the sync again; successful
052605_roll1		NeC-MSC	NeC-MSC				sensors_VER13.xls	sample3000r5.hed	sample10000r3.hed	
052605_roll2		Ivy City Yard	Ivy City Yard				sensors_VER13.xls	sample3000r5.hed	sample10000r3.hed	
052605_roll3		Ivy City Yard	Ivy City Yard				sensors_VER13.xls	sample3000r5.hed	sample10000r3.hed	
052605_roll4		Ivy City Yard	Union Station				sensors_VER13.xls	sample3000r5.hed	sample10000r3.hed	
052605_01	052605_01	Union Station Wash DC	Baltimore, MD			Track 3	sensors_VER13.xls	sample3000r5.hed	sample10000r3.hed	Observed saturation on lateral accels; sign issue with strains (ENSCO); signs were changed on all strain gages in Baltimore; print outs modified
052605_02	052605_02	Baltimore, MD	Wilmington			Track 2	sensors_VER13.xls	sample3000r5.hed	sample10000r3.hed	t-700, high lat/vert activity, high strains t-865 neg noise spikes on some strains; t-1570-1656 lost power to SCU2; 1/2 of channels lost t-2060 poss noise spike on Sp6 gages
052605_03	052605_03	Wilmington	MP AP5			Track 1, Track 2	sensors_VER13.xls	sample3000r5.hed	sample10000r3.hed	switch to Tr 2 near AP16; lateral accel 2 (piezoelectric on axle) stopped working (const up/down drift) stopped behaving this way ~MP AP8
052605_04	052605_04	Philadelphia	MP AN 84.5				sensors_VER13.xls	sample3000r5.hed	sample10000r3.hed	Labview System Crash Stopped Collection; High Speed System Continued to Collect ~45 secs
052605_05	052605_05	MP AN 82	Newark NJ				sensors_VER13.xls	sample3000r5.hed	sample10000r3.hed	Gage on Spoke 6F2 starting to get noisy (lg spikes) consistently; noise spikes on Spoke 3R2, Spoke 6F1 seeing a bit on Spoke 3 R1 as well Near MP AN12 (t-2300) big vert hit & activity; t=2340 MOANING OF BRAKES AND BIG STRAINS DURING BRAKING
052605_06	052605_06	Newark NJ	New York (MP W3)				sensors_VER13.xls	sample3000r5.hed	sample10000r3.hed	strain signals are not noisy anymore
052605_07	052605_07	New York, NY (MP E6)	New York (MP E 14)			Track 2	sensors_VER13.xls	sample3000r5.hed	sample10000r3.hed	t=420 HIGH STRAINS ON BRAKING no moaning on instr axle
052605_08	052605_08	New York (MP E 15)	MP MN55			Track 2 (on MN) Sw to Track 4 MN @ MN23	sensors_VER13.xls	sample3000r5.hed	sample10000r3.hed	t=156 HIGH STRAINS ON BRAKING no moaning on instr axle t-2000 Mild case of high strains during braking near MP MN 44
052605_09	052605_09	MP MN55.5	MP MN 65			Start on MN Tr 4	sensors_VER13.xls	sample3000r5.hed	sample10000r3.hed	t-200 Mild case of high strains during braking
052605_10	052605_10	MP MN 65	MP MN 72 New Haven			On MN Tr 4	sensors_VER13.xls	sample3000r5.hed	sample10000r3.hed	spoke 3 R2 a bit noisy @t-180
052605_11	052605_11	MP MN 72 New Haven	MP AB 75			Start Amtrak Track 1	sensors_VER13.xls	sample3000r5.hed	sample10000r3.hed	little lateral jolt @ t-105; CSP6F1 noise spikes around t-150

Acela Brake Disc Test - Test Log

Date 26-May-05
 Test Run Washington to Boston, 7-inch Cant Deficiency Run
 Train Configuration Car 3413 on Lead End of Consist (PC 2038 Leading)
 Sample Rate 3000 samples/sec on ENSCO System, 10,000 Hz on Amtrak System
 Anti-Alias Filter Setting Set to 1000 Hz for ENSCO System Only; No Anti-Alias Filter Used on Amtrak System

3kHz (32 ch) System Filename (*ABT, *CAL, *GPS)	10kHz (16 ch) System Filename (*001)	Start Location	End Location	Track (if avail)	Channels	Header (3kHz)	Header (10kHz)	Comments
052605_12	052605_12	MP AB 75	MP AB 105	Switch to Tr 2 @ t=400 Start on Amtrak Tr2	sensors_VER13.xls	sample3000r5.hed	sample10000r3.hed	still have noise on CSPK3 R2; t=400 HIGH STRAINS FOR LONG DURATION DURING BRAKING NEAR MP AB 85 t=600 HIGH STRAINS FOR LONG DURATION DURING BRAKING NEAR MP AB 90 CSPK6 F2 noisy prior to braking @ MP AB 90, cleared up after braking
052605_13	052605_13	MP AB 105	New London CT (MP AB 123)	Amtrak Tr2	sensors_VER13.xls	sample3000r5.hed	sample10000r3.hed	t=90, spikes in vertical and strains on bridge t=480 MP AB116 HIGH STRAINS BRAKING INTO CURVE FOLLOWED BY VERTICAL HITS ON BRIDGE
052605_14	052605_14	New London CT (MP AB 123)	MP AB 134	Amtrak Tr2	sensors_VER13.xls	sample3000r5.hed	sample10000r3.hed	No Significant Activity
052605_15	052605_15	MP AB 134	MP AB 185	Amtrak Tr2	sensors_VER13.xls	sample3000r5.hed	sample10000r3.hed	Bit of noise develop on CSPK3 R2 t-370; t-915, noise spikes on some gages t=984 @ MP AB159 Braking from 150-60 MPH HIGH STRAINS DURING BRAKING; ALMOST +/- 1000uE, used suppression braking (1/2 pressure), planned braking t-1212 SMALL CASE OF ACTIVITY DUE TO BRAKING; Noise spikes near t-1330 t=1580 @ ~MP AB179 Braking HIGH STRAINS DURING BRAKING; used braking of ~35psi (recorded sound file 052605_09.WAV)
052605_16	052605_16	MP AB 185	?	Amtrak Tr2	sensors_VER13.xls	sample3000r5.hed	sample10000r3.hed	LABVIEW CRASH ENDED COLLECTION; high speed system continued to collect
052605_17	052605_17	MP AB 200	Rte 128 Station	Amtrak Tr2	sensors_VER13.xls	sample3000r5.hed	sample10000r3.hed	t=110 @ ~MP AB203 Braking HIGH STRAINS DURING BRAKING; t=456 @ ~MP AB217 Braking HIGH STRAINS DURING BRAKING;
052605_18	052605_18	Rte 128 Station	Boston Terminal	Amtrak Tr2	sensors_VER13.xls	sample3000r5.hed	sample10000r3.hed	No Significant Activity

Sound Files

Filename	Start Location	Comments
052605_01.WAV	MP AP 113	Lat Accels Show Signs of Saturation
052605_02.WAV	MP AP 62	Brake Sound?, moderate braking
052605_03.WAV	MP AP 31	Brake Sound?, moderate braking
052605_06.WAV	~MP AN 11	Moaning of brakes during braking with high strain activity
052605_09.WAV	~MP AB 179	Braking with high strain activity

Acela Brake Disc Test - Test Log

Date 27-May-05
 Test Run Boston to Washington, 7-inch Cant Deficiency Run
 Train Configuration Car 3413 on Trail of Consist (PC 2016 Leading)
 Sample Rate 3000 samples/sec on ENSCO System, 10,000 Hz on Amtrak System
 Anti-Alias Filter Setting Set to 1000 Hz for ENSCO System Only; No Anti-Alias Filter Used on Amtrak System

3kHz (32 ch) System		10kHz (16 ch) System		Track (if avail)	Channels	Header (3kHz)	Header (10kHz)	Comments
Filename (*ABT, *CAL, *GPS)	Filename (*001)	Start Location	End Location					
052705_zero		Boston Facility	Boston Facility		sensors_VER13.xls	sample3000r5.hed	sample10000r3.hed	zeroes the gages and the accelerometers
052705_shunt		Boston Facility	Boston Facility		sensors_VER13.xls	sample3000r5.hed	sample10000r3.hed	shunting strain gages
052705_shuntaxle Lat2		Boston Facility	Boston Facility		sensors_VER13.xls	sample3000r5.hed	sample10000r3.hed	shunting PR accel on axle
052705_freq		Boston Facility	Boston Facility		sensors_VER13.xls	sample3000r5.hed	sample10000r3.hed	channels 1 and 17, 164 Hz
052705_sweep		Boston Facility	Boston Facility		sensors_VER13.xls	sample3000r5.hed	sample10000r3.hed	Chs 1 & 17, 100 to 8K 5 secs 2V Pk-to-Pk sine wave
052705_sine		Boston Facility	Boston Facility		sensors_VER13.xls	sample3000r5.hed	sample10000r3.hed	channels 1 and 17, 200Hz 2V peak to peak sine wave
052705_sync		Boston Facility	Boston Facility		sensors_VER13.xls	sample3000r5.hed	sample10000r3.hed	sync test of the 2 systems
052705_sweep2		Boston Facility	Boston Facility		sensors_VER13.xls	sample3000r5.hed	sample10000r3.hed	sweep 1 bad sine; wave not triangular; filename should be sync2
052705_zero2		South Street Sta.	South Street Sta.		sensors_VER13.xls	sample3000r5.hed	sample10000r3.hed	re-zero axle strain gages only
052705_zero3		South Street Sta.	South Street Sta.		sensors_VER13.xls	sample3000r5.hed	sample10000r3.hed	re-zero all strain gages only
052705_01	052705_01	South Street Sta.	Rte 128 Sta	Track 1	sensors_VER13.xls	sample3000r5.hed	sample10000r3.hed	After departure, adjusted disc temperature (with TC)
052705_02	052705_02	Rte 128 Sta	~ MP AB193.5	Track 1	sensors_VER13.xls	sample3000r5.hed	sample10000r3.hed	Caliper Pad Accels bad t~160,650-700
052705_03	052705_03	~ MP AB193.5	~ MP AB193.5	Sw to Track 2 @ t~740 (MP AB 199)	sensors_VER13.xls	sample3000r5.hed	sample10000r3.hed	No Significant Data
052705_04	052705_04	~ MP AB193.5	Providence Sta.	Track 2	sensors_VER13.xls	sample3000r5.hed	sample10000r3.hed	No Significant Data
052705_05	052705_05	Providence Sta.	~MP AB 160	Sw to Track 1 @ t~490 (MP AB 186)	sensors_VER13.xls	sample3000r5.hed	sample10000r3.hed	No Significant Data
052705_06	052705_06	~MP AB 160	~MP AB 159	Track 1	sensors_VER13.xls	sample3000r5.hed	sample10000r3.hed	No Significant Data
052705_07	052705_07	~MP AB 159	New London CT (MP AB 124)	Track 1	sensors_VER13.xls	sample3000r5.hed	sample10000r3.hed	No Significant Data
052705_08	052705_08	New London CT (MP AB 122)	~MP AB 77	Track 1	sensors_VER13.xls	sample3000r5.hed	sample10000r3.hed	Noise spikes on Spoke6F2 off and on; t=1236 LATERAL HIT BUT NO ACTIVITY ON STRAINS
052705_09	052705_09	~MP AB 76	New Haven CT (~MP 72)	Track 1	sensors_VER13.xls	sample3000r5.hed	sample10000r3.hed	No Significant Data
052705_10	052705_10	New Haven CT (~MP 72)	MP MN 53	Track 1 Metro North	sensors_VER13.xls	sample3000r5.hed	sample10000r3.hed	No Significant Data
052705_11	052705_11	MP MN 53	MP MN 53	Track 1 Metro North	sensors_VER13.xls	sample3000r5.hed	sample10000r3.hed	LABVIEW CRASH ENDED COLLECTION; high speed system continued to collect
052705_12	052705_12	MP MN 50	MP MN 33	Track 1 Metro North	sensors_VER13.xls	sample3000r5.hed	sample10000r3.hed	No Significant Data
052705_13	052705_13	MP MN 32	MP MN 17	Track 1 Metro North	sensors_VER13.xls	sample3000r5.hed	sample10000r3.hed	No Significant Data
052705_14	052705_14	MP MN 17	MP E19		sensors_VER13.xls	sample3000r5.hed	sample10000r3.hed	LABVIEW CRASH ENDED COLLECTION; high speed system continued to collect
052705_15	052705_15	MP E18	New York		sensors_VER13.xls	sample3000r5.hed	sample10000r3.hed	No Significant Data
052705_16	052705_16	New York	New York		sensors_VER13.xls	sample3000r5.hed	sample10000r3.hed	LABVIEW CRASH ENDED COLLECTION; high speed system continued to collect
052705_17	052705_17	New York	~Secaucus NJ Station	Track 3	sensors_VER13.xls	sample3000r5.hed	sample10000r3.hed	No GPS file
052705_18	052705_18	~MP W6	Newark NJ	Track 3	sensors_VER13.xls	sample3000r5.hed	sample10000r3.hed	No Significant Data
052705_19	052705_19	Newark NJ	MP AN 40	Track 3	sensors_VER13.xls	sample3000r5.hed	sample10000r3.hed	Noise develop on Spoke6 F2 gage
052705_20	052705_20	MP AN 41	MP AN 84.5	Track 3	sensors_VER13.xls	sample3000r5.hed	sample10000r3.hed	t~517, spoke 6 F1 & F2 noisy; notice Axle Lat 3 high response in curves
052705_21	052705_21	Philadelphia Sta	MP AP 10	Track 3	sensors_VER13.xls	sample3000r5.hed	sample10000r3.hed	No Significant Data
052705_22	052705_22	MP AP 10	Wilmington Station	Track 3	sensors_VER13.xls	sample3000r5.hed	sample10000r3.hed	No Significant Data
052705_23	052705_23	MP AP 27	MP AP 61	Track 3	sensors_VER13.xls	sample3000r5.hed	sample10000r3.hed	No Significant Data
052705_24	052705_24	MP AP 61	MP AP 64	Track 3	sensors_VER13.xls	sample3000r5.hed	sample10000r3.hed	Noise develop on Spoke6 F1 gage
052705_25	052705_25	MP AP 65	MP AP 74	Track 3	sensors_VER13.xls	sample3000r5.hed	sample10000r3.hed	No Significant Data
052705_26	052705_26	MP AP 75	MP AP 78	Track 3	sensors_VER13.xls	sample3000r5.hed	sample10000r3.hed	No Significant Data
052705_27	052705_27	MP AP 79	MP AP 89	Track 3	sensors_VER13.xls	sample3000r5.hed	sample10000r3.hed	No Significant Data
052705_28	052705_28	MP AP 89	Baltimore Station	Track 3	sensors_VER13.xls	sample3000r5.hed	sample10000r3.hed	No Significant Data
052705_29	052705_29	Baltimore Station	BWI Station	Track 3	sensors_VER13.xls	sample3000r5.hed	sample10000r3.hed	No Significant Data
052705_30	052705_30	BWI Station	MP AP 134	Track 3	sensors_VER13.xls	sample3000r5.hed	sample10000r3.hed	No Significant Data

Acela Brake Disc Test - Test Log

Date 16-Jun-05
 Test Run Washington-NY-Washington, 7-inch Cant Deficiency Speed Profile
 Train Configuration Cars 3413, 3534 on Lead of Consist (PC 2038 Leading) to NY: Cars 3413, 3534 on Trail of Consist (PC 2038 Trailing)
 Sample Rate 3000 samples/sec
 Anti-Alias Filter Setting 800 Hz
 Header File Used sample3000_65r5.hed

3kHz (65 ch) System

Filename (* .AB3, * .CAL, * .GPS)	Start Location	End Location	Track (if avail)	Channel List/Settings	Comments
061605_zero	NeC-MSC	NeC-MSC		sensors_VER22.xls	zero strain gages, accels
061605_shunt	NeC-MSC	NeC-MSC		sensors_VER22.xls	
061605_sweep1	NeC-MSC	NeC-MSC		sensors_VER22.xls	used "sync" channel
061605_sweep2	NeC-MSC	NeC-MSC		sensors_VER22.xls	used CTRSPK6F2
061605_sweep3	NeC-MSC	NeC-MSC		sensors_VER22.xls	USED CTR2SPK4_6
061605_sweep4	NeC-MSC	NeC-MSC		sensors_VER22.xls	used LBOXVert2
061504_freq1	NeC-MSC	NeC-MSC		sensors_VER22.xls	used "sync" channel w/88Hz
061504_freq2	NeC-MSC	NeC-MSC		sensors_VER22.xls	used CTRSPK6F2 w/88Hz
061504_freq3	NeC-MSC	NeC-MSC		sensors_VER22.xls	USED CTR2SPK4_6 w/88Hz
061504_freq4	NeC-MSC	NeC-MSC		sensors_VER22.xls	used LBOXVert2 w/88Hz
061605ivycity1	NeC-MSC	Ivy City Yard		sensors_VER22.xls	
061605ivycity2	Ivy City Yard	Ivy City Yard		sensors_VER22.xls	
061605ivycity3	Ivy City Yard	Ivy City Yard		sensors_VER22.xls	
061605ivycity4	Ivy City Yard	Union Station		sensors_VER22.xls	
061605_01	Union Station	~MP 101 AB	Track 2	sensors_VER22.xls	No GPS t~350, brake appl; t~450 lost temp sensor, then came back CTR2SPK3_R2 noisy off and on; t~630 brake application; t~880 VERT HITS WABTEC/SAB-WABCO axle more active than Knorr axle sync signal no good for first file.
061605_02	~MP 101 AB	Baltimore Sta	Track 2	sensors_VER22.xls	Stopped to fix speed signal (sine wave) and GPS
061605_03	Baltimore Sta	~Bush River	Track 3	sensors_VER22.xls	GPS failure 10 seconds in t~640 brake application? t~720 vertical hits on bridge t~920 brake appl SMALL AMOUNT OF OSCILL DURING BRAKING , tried to capture sound
061605_04	~Bush River	~MP 51AP	Track 2	sensors_VER22.xls	t~160 brake appl SMALL AMOUNT OF OSCILL DURING BRAKING
061605_05	~MP 51AP	Wilmington Station	Track 2	sensors_VER22.xls	t~260 vertical activity; t~345 big vertical hit t~390 BIG VERTICAL HIT WABTEC/SAB-WABCO axle more active than Knorr axle t~620 BRAKE APPLICATION W/SMALL AMPLITUDE OSCILLATION, FOLLOWED

Acela Brake Disc Test - Test Log

Date 16-Jun-05
 Test Run Washington-NY-Washington, 7-inch Cant Deficiency Speed Profile
 Train Configuration Cars 3413, 3534 on Lead of Consist (PC 2038 Leading) to NY: Cars 3413, 3534 on Trail of Consist (PC 2038 Trailing)
 Sample Rate 3000 samples/sec
 Anti-Alias Filter Setting 800 Hz
 Header File Used sample3000_65r5.hed

3kHz (65 ch) System					
Filename					
(* .AB3, * .CAL, * .GPS)	Start Location	End Location	Track (if avail)	Channel List/Settings	Comments
061605_06	Wilmington	Near Philadelphia Yard		sensors_VER22.xls	BY BIG VERTICAL HIT t~95, 108 BIG VERTICAL HITS WABTEC/SAB-WABCO axle more active than Knorr axle t~285 BIG VERTICAL HITS WABTEC/SAB-WABCO axle more active than Knorr axle t~405,411 VERTICAL HITS; t~925, VERY SMALL BRAKE OSCILL ON WABTEC/SAB-WABCO DISC
061605_07	Near Philadelphia Yard	Philadelphia 30th Street Sta		sensors_VER22.xls	Nothing of Interest
061605_08	Philadelphia 30th Street	~MP 69 AN		sensors_VER22.xls	t~70-80, 160 - Elevated activity on WABTEC/SAB-WABCO disc more active than Knorr axle t~225, 337 BIG VERTICAL ACTIVITY WABTEC/SAB- WABCO axle more active than Knorr axle t~550 elevated activity on WABTEC/SAB-WABCO disc in curve t~70 heard squeeling though curve, recorded sound file t~97 VERY LARGE VERTICAL HIT WABTEC/SAB-WABCO axle more active than Knorr axle t~562 SMALL OSCILLATION DURING BRAKING
061605_09	~MP 69 AN	~MP 48AN		sensors_VER22.xls	
061605_10	~MP 48AN	~MP 21AN		sensors_VER22.xls	
061605_11	~MP 21AN	Newark, NJ		sensors_VER22.xls	t~40-50, LARGE VERTICAL HITS WABTEC/SAB-WABCO axle more active than Knorr
061605_12	Newark, NJ	~MP 7AN		sensors_VER22.xls	
061605_13	~MP 6AN	New York Penn Sta		sensors_VER22.xls	
Switched CTRSPK6_R2 & CTRSPK6_R1 from Amplifier 1-3,1-4 to 1-7,1-8					
061605_14	New York Penn Sta	Secacaus,NJ		sensors_VER24.xls	
061605_15	Secacaus,NJ	Newark, NJ		sensors_VER24.xls	t~190 saw activity in brake mount tri-axial accel
061605_16	Newark, NJ	~MP 30AN		sensors_VER24.xls	t~90 vertical hit t~200 during braking, saw Knorr Br Mount tri-axial accel vibrating +/-4g but no action on WABTEC/SAB-WABCO t~500 long braking with activity on Knorr brake mount accel t~840 long braking with activity on Knorr brake mount accel

Acela Brake Disc Test - Test Log

Date 16-Jun-05
 Test Run Washington-NY-Washington, 7-inch Cant Deficiency Speed Profile
 Train Configuration Cars 3413, 3534 on Lead of Consist (PC 2038 Leading) to NY: Cars 3413, 3534 on Trail of Consist (PC 2038 Trailing)
 Sample Rate 3000 samples/sec
 Anti-Alias Filter Setting 800 Hz
 Header File Used sample3000_65r5.hed

3kHz (65 ch) System

Filename (* .AB3, * .CAL, * .GPS)	Start Location	End Location	Track (if avail)	Channel List/Settings	Comments
061605_17	~MP 30AN	~MP 55AN	Track 3	sensors_VER24.xls	t~290 noise again on CTR2SPK3_R2, then went away; intermittent
061605_18	~MP 55AN	N. Philadelphia	Track 3	sensors_VER24.xls	"Noisy" signal on WABTEC/SAB-WABCO axle disc temperature t~470, VERTICAL HITS WABTEC/SAB-WABCO axle more active than Knorr t~630 appeared to be a lateral hit only Noise reappear on CTR2SPK3_R2
061605_19	N. Philadelphia	Philadelphia 30th Street Sta		sensors_VER24.xls	
061605_20	Philadelphia 30th Street	~Wilmington, DE		sensors_VER24.xls	t~920 Disconnected CTR2SPK3_R2
061605_21	Wilmington Sta	~Newark DE		sensors_VER24.xls	t~80 Axle1 CTRSPK6R1 Died; t~220 AXLE2CSPK6 Died
061605_22	~Newark DE	~MP 61AP		sensors_VER24.xls	
061605_23	~MP 62AP	MP 87AP		sensors_VER24.xls	
061605_24	MP 88AP	Baltimore Station		sensors_VER24.xls	
061605_25	Baltimore	Within Baltimore Tunnel		sensors_VER24.xls	Discovered AXLE2CSPK3 Disabled
061605_26	Within Baltimore Tunnel	MP 106AP		sensors_VER24.xls	Working on Strain Gage Connections
061605_27	MP 106AP	Near Ivy City		sensors_VER24.xls	t~200 high strains during braking, very low amplitude motion

Sound Files

Filename	Start Location
061605_01.WAV	~Bush River
061605_02.WAV	~MP 68AN

Acela Brake Disc Test - Test Log

Date 17-Jun-05
 Test Run Washington-Boston, 90-inch Cant Deficiency Speed Profile
 Train Configuration Cars 3413, 3534 on Lead of Consist (PC 2038 Leading) to Boston
 Sample Rate 3000 samples/sec
 Anti-Alias Filter Setting Set to 800 Hz, Calculated at 750 Hz
 Header File Used sample3000_65r5.hed

3kHz (65 ch) System
 Filename

(*AB3, *.CAL, *.GPS)	Start Location	End Location	Track (if avail)	Channel List/Settings	Comments
board1	NeC-MSC	NeC-MSC		sensors_VER25.xls	used "sync" channel w/95 Hz 2 V Pk-Pk
board2	NeC-MSC	NeC-MSC			used CTRSPK6F1 w/95 Hz 2 V Pk-Pk
board3	NeC-MSC	NeC-MSC			used AXLE1RLINK w/95 Hz 2 V Pk-Pk
board4	NeC-MSC	NeC-MSC			used LBOXLat1 w/95 Hz 2 V Pk-Pk
sweep1	NeC-MSC	NeC-MSC			used "sync" channel w/4.0 V Pk-Pk sin w/100Hz-3KHz over 5 seconds
sweep2	NeC-MSC	NeC-MSC			used CTRSPK6F1 w/4.0 V Pk-Pk sin w/100Hz-3KHz over 5 seconds
sweep3	NeC-MSC	NeC-MSC			used AXLE1RLINK w/4.0 V Pk-Pk sin w/100Hz-3KHz over 5 seconds
sweep4	NeC-MSC	NeC-MSC			used LBOXLat1 w/4.0 V Pk-Pk sin w/100Hz-3KHz over 5 seconds
zeroes	NeC-MSC	NeC-MSC			zero strain gages, accels
shunt	NeC-MSC	NeC-MSC			All strain gages shunted; CTR2SPK6_4 WILL NOT SHUNT, BLACK LEAD OPEN
061705_ivycity1	NeC-MSC	NeC-MSC			Moving in Yard
061705_ivycity2	Ivy City Yard	Ivy City Yard			
061705_ivycity3	Ivy City Yard	Union Station			CTR2SPK6_4 is Open, AXLE2CSPK6_5 VERY NOISY
061705_01	Union Station	~MP AP131			
061705_02	~MP AP131	~MP AP 99			AXLE2CSPK6 seems a bit noisy from time to time CTR2SPK3R2 intermittent noise (hash on top of signal) t~825 BIG VERTICAL HIT WABTEC/SAB-WABCO axle more active than Knorr axle some braking towards end of file
061705_03	~MP AP99	Baltimore Tunnel			
061705_04	Baltimore Tunnel	Baltimore Tunnel			t~95 BRAKE APPLICATION, MED LEVEL OSCILL IN WABTEC/SAB-WABCO DISC
061705_05	Baltimore Tunnel	Baltimore Station			Nothing of Interest, Short File
061705_06	Baltimore Station	~MP AP48			t~475 BIT OF OSCILL ON WABTEC/SAB-WABCO DISC DURING BRAKING t~530 interesting signal on Faively disk gages ~MP 83 t~830 MUCH VERTICAL ACTIVITY t~1270 VERTICAL ACTIVITY ON BRIDGE t~1370 VERTICAL ACTIVITY t~1580 Some oscillation observed
061705_07	~MP AP47	~MP AP28	Track 2		
061705_08	Wilmington Sta	Wilmington Sta	Track 2		Odd Oscillation in Spokes as Rolling

Acela Brake Disc Test - Test Log

Date 17-Jun-05
 Test Run Washington-Boston, 90-inch Cant Deficiency Speed Profile
 Train Configuration Cars 3413, 3534 on Lead of Consist (PC 2038 Leading) to Boston
 Sample Rate 3000 samples/sec
 Anti-Alias Filter Setting Set to 800 Hz, Calculated at 750 Hz
 Header File Used sample3000_65r5.hed

3kHz (65 ch) System
 Filename

(*AB3, *.CAL, *.GPS)	Start Location	End Location	Track (if avail)	Channel List/Settings	Comments
061705_09	Wilmington Sta	~MP AP 8.5	Track 2		t~255, 285-400, 510 Vertical Activity t~580 VERTICAL HIT @ BEGINNING OF BRAKING
061705_10	~MP AP 8.5	Philadelphia	Track 2		t~135-150 LATERAL ACTIVITY, RBOXVERT2 showed signs of saturation t~205 BRAKING OSCILLATION ON WABTEC/SAB-WABCO DISC
061705_11	Philadelphia	MP AN63.5	Track 2		t=555-570 MUCH ACTIVITY ON WABTEC/SAB-WABCO DISC WHILE CURVING t~708 VERTICAL ACTIVITY t~725, 915-930, 1070 SATURATION OF LBOXVERT2 DURING CURVING TILT SYSTEM FAILED t~1060 VERTICAL ACTIVITY
061705_12	MP AN63	MP AN56	Track 2		Nothing of Interest
061705_13	MP AN56	MP AN21	Track 2		TILT SYSTEM RESTORED t~430-450 VERTICAL ACTIVITY t~885-900 MUCH LATERAL/VERTICAL ACTIVITY
061705_14	MP AN20.5	MP AN11	Track 2		t~35-50 LARGE VERTICAL ACTIVITY t~155 Small Oscill During Braking t~320 VERTICAL ACTIVITY
061705_15	MP AN11	Newark Station	Track 2		t~60,87 VERTICAL ACTIVITY
061705_16	Newark	MP AN7			t~205 Small Amplitude Oscillation During Braking Notice Noise on WABTEC/SAB-WABCO Axle Disk Temp and Cyl Press at end of file
061705_17	MP AN7	NY Penn Station			Notice Noise on WABTEC/SAB-WABCO Axle Disk Temp at begin of file
061705_18	NY Penn Station	~MP E18			
061705_19	~MP E18.5	MP MN22			t~350 OSCILLATION OF WABTEC/SAB-WABCO DISK DURING BRAKING
061705_20	MP MN22	MP MN23			Nothing of Interest
061705_21	MP MN23	~MP MN 39			t~150-170,310,865 OSCILLATION OF WABTEC/SAB-WABCO DISK DURING BRAKING t~350-370 LARGE VERTICAL ACTIVITY t~120 Brake Activity
061705_22	MP MN 39	~MP MN 42			t~30,165,620 OSCILLATION OF WABTEC/SAB-WABCO DISK DURING BRAKING
061705_23	~MP MN 43	~MP MN 55			t~80 LARGE VERTICAL ACTIVITY
061705_24	~MP MN 55	MP MN 60			t~270, End of File, BRAKING OSCILL ON WABTEC/SAB-WABCO DISC

Acela Brake Disc Test - Test Log

Date 17-Jun-05
 Test Run Washington-Boston, 90-inch Cant Deficiency Speed Profile
 Train Configuration Cars 3413, 3534 on Lead of Consist (PC 2038 Leading) to Boston
 Sample Rate 3000 samples/sec
 Anti-Alias Filter Setting Set to 800 Hz, Calculated at 750 Hz
 Header File Used sample3000_65r5.hed

3kHz (65 ch) System
 Filename

(*AB3, *.CAL, *.GPS)	Start Location	End Location	Track (if avail)	Channel List/Settings	Comments
061705_25	MP MN 60	MP MN 72			t~170,220,305,490,555,630 BRAKING OSCILL ON WABTEC/SAB-WABCO
061705_26	MP MN 72	MP MN 72			Oscillation During Braking, Short File
061705_27	MP MN 73	MP MN 73			Oscillation During Braking, Short File
061705_28	MP MN 73	MP AB95			t~610 Odd Oscillations After Applications
061705_29	MP AB97	MP AB104			t~120 MAJOR OSCILLATION OF WABTEC/SAB-WABCO DISC DURING BRAKING!!!!!! t~240 OSCILLATION OF WABTEC/SAB-WABCO DISC DURING BRAKING
061705_30	MP AB104	MP AB116			t~180, 405 SMALL OSCILLATION OF WABTEC/SAB-WABCO DISC DURING BRAKING t~210 HIGH VERTICAL ACTIVITY t~560 HIGH AMPLITUDE OSCILLATION OF WABTEC/SAB-WABCO DISC DURING BRAKING
061705_31	MP AB116	~MP AB 122			t~95, 165 OSCILLATION OF WABTEC/SAB-WABCO DISC DURING BRAKING t~120 LONG OSCILLATION, SMALL AMPLITUDE OF WABTEC/SAB-WABCO DISC DURING BRAKING
061705_32	~MP AB 122	MP AB126			t~170 HIGH ACTIVITY ON WABTEC/SAB-WABCO DISC WITH NO BRAKING IN CURVE t~335 OSCILL DURING BRAKING ON WABTEC/SAB-WABCO DISC; t~385 HIGH OSCILL DURING BRAKING ON WABTEC/SAB-WABCO DISC t~350 HIGH ACTIVITY ON WABTEC/SAB-WABCO DISC IN CURVE
061705_33	MP AB126	MP AB129			t=0 OSCILL OF WABTEC/SAB-WABCO DISC DURING BRAKING t~70 VERY LARGE OSCILLATION OF WABTEC/SAB-WABCO DISC DURING BRAKING
061705_34	MP AB130	MP AB138			t~90-115 LONG OSCILLATION OF WABTEC/SAB-WABCO DISC DURING BRAKING t~220 OSCILL OF WABTEC/SAB-WABCO DISC DURING BRAKING t~420 VERY LARGE OSCILLATION OF WABTEC/SAB-WABCO DISC DURING BRAKING
061705_35	MP AB138	MP AB140			t~80-110 VERY LARGE OSCILLATION OF WABTEC/SAB-WABCO DISC DURING BRAKING

Acela Brake Disc Test - Test Log

Date 17-Jun-05
 Test Run Washington-Boston, 90-inch Cant Deficiency Speed Profile
 Train Configuration Cars 3413, 3534 on Lead of Consist (PC 2038 Leading) to Boston
 Sample Rate 3000 samples/sec
 Anti-Alias Filter Setting Set to 800 Hz, Calculated at 750 Hz
 Header File Used sample3000_65r5.hed

3kHz (65 ch) System

Filename (*.AB3, *.CAL, *.GPS)	Start Location	End Location	Track (if avail)	Channel List/Settings	Comments
061705_36	MP AB140	MP AB 156			t~130-140 VERY LARGE OSCILLATION OF WABTEC/SAB-WABCO DISC DURING BRAKING 2000uE pk-pk from 90 mph
061705_37	MP AB 156	MP AB 160			t~45 VERY HIGH VERY LONG OSCILLATION OF WABTEC/SAB-WABCO DISC DURING BRAKING FULL SERVICE BRAKE APPLICATION FROM 150 mph
061705_38	MP AB 160	MP AB 186			t~540 OSCILL OF WABTEC/SAB-WABCO DISC DURING BRAKING, SOUND RECORDED
061705_39	MP AB 186	MP AB 187			SHORT FILE, MILD ACTIVITY DURING CURVING

END OF TESTING

Sound Files

Filename	Start Location	
061705_01.WAV	~MP MN 47	
061705_02.WAV	~MP MN 59	
061705_03.WAV	~MP MN 72	
061705_04.WAV	~MP AB 179	BRAKING

Acela Brake Disc Test - Test Log

Date 18-Jun-05
 Test Run Boston-Washington, 9-inch Cant Deficiency Speed Profile
 Train Configuration Cars 3413, 3534 on Lead of Consist (PC 2038 Leading) to Washington
 Sample Rate 3000 samples/sec
 Anti-Alias Filter Setting Set to 800 Hz, Calculated at 750 Hz
 Header File Used sample3000_65r5.hed

3kHz (65 ch) System					
Filename					
(*AB3, *.CAL, *.GPS)	Start Location	End Location	Track (if avail)	Channel List/Settings	Comments
zeroes shunt	South Street Station South Street Station	South Street Station South Street Station		sensors_VER25.xls	zero strain gages, accels All strain gages shunted; CTR2SPK6_4 WILL NOT SHUNT (BLACK LEAD OPEN), CTR2SPK4_6 WILL NOT SHUNT
board1	South Street Station	South Street Station			used "sync" channel w/82 Hz 4 V Pk-Pk
board2	South Street Station	South Street Station			used CTRSPK6F1 w/81 Hz 4 V Pk-Pk
board3	South Street Station	South Street Station			used CTR2SPK6_5 w/81 Hz 4 V Pk-Pk
board4	South Street Station	South Street Station			used AXLE2OSPK3 w/81 Hz 4 V Pk-Pk
sweep1	South Street Station	South Street Station			used "sync" channel w/4.0 V Pk-Pk sin w/100Hz-3KHz over 5 seconds
sweep2	South Street Station	South Street Station			used CTRSPK6F1 w/4.0 V Pk-Pk sin w/100Hz-3KHz over 5 seconds
sweep3	South Street Station	South Street Station			used CTR2SPK6_5 w/4.0 V Pk-Pk sin w/100Hz-3KHz over 5 seconds
sweep4	South Street Station	South Street Station			used AXLE2OSPK3 w/4.0 V Pk-Pk sin w/100Hz-3KHz over 5 seconds
061805_01	South Street Station	MP 225AB			t~270,295,313 VERTICAL ACTIVITY
061805_02	MP 225AB	Rte 128			t~325 Short signs of oscill on WABTEC/SAB-WABCO Disc during braking
061805_03	Rte 128	~MP 201.5AB			t~475 LARGE OSCILLATION OF WABTEC/SAB-WABCO DISC DURING BRAKING, FS Stop from 150 MPH
061805_04	~MP AB 201.5	Providence Station			t~233,345 Mild Activity on WABTEC/SAB-WABCO Disc During Braking t~415 Activity on WABTEC/SAB-WABCO Disc During Curving
061805_05	Providence Station	~MP AB 176.5	Track 1		t~530-550 LARGE OSCILLATION OF WABTEC/SAB-WABCO DISC DURING BRAKING FS Stop
061805_06	~MP AB 176.5	~MP AB 160	Tr 2 @t=370 Tr2		t~240 HIGH ACTIVITY ON WABTEC/SAB-WABCO DISC DURING FS BRAKING
			Sw to Tr 1~t350		t~505-542 HIGH ACTIVITY ON WABTEC/SAB-WABCO DISC DURING FS BRAKING
061805_07	~MP AB 160	~MP AB 140	Track 1		t~30 HIGH ACTIVITY ON WABTEC/SAB-WABCO DISC DURING BRAKING FS Braking from 125 MPH t~160 HIGH ACTIVITY ON WABTEC/SAB-WABCO DISC DURING BRAKING FS Braking from 115 MPH
061805_08	~MP AB 140	~MP AB 133 Mystic CT	Track 1		
061805_09	~MP AB 131	MP AB 114	Track 1		t~255,420 ACTIVITY ON WABTEC/SAB-WABCO DISC DURING CURVING
061805_10	MP AB 114	MP AB 99	Track 1		

Acela Brake Disc Test - Test Log

Date 18-Jun-05
 Test Run Boston-Washington, 9-inch Cant Deficiency Speed Profile
 Train Configuration Cars 3413, 3534 on Lead of Consist (PC 2038 Leading) to Washington
 Sample Rate 3000 samples/sec
 Anti-Alias Filter Setting Set to 800 Hz, Calculated at 750 Hz
 Header File Used sample3000_65r5.hed

3kHz (65 ch) System

Filename (*AB3, *.CAL, *.GPS)	Start Location	End Location	Track (if avail)	Channel List/Settings	Comments
061805_11	MP AB 99	MP AB 77	Track 1		t~270,360 Braking w/no real activity
061805_12	MP AB 77	MP MN 62			t~250 Bit of Activity on WABTEC/SAB-WABCO Disc Through Curve
061805_13	~MP MN 61	~MP MN 47			
061805_14	~MP MN 47	~MP MN 31			
061805_15	~MP MN 31	~MP MN 23			t~150 VERTICAL ACTIVITY ON WABTEC/SAB-WABCO DISC
061805_16	~MP MN 23	MP E 12			At end of file, long braking with no activity
061805_17	MP E 12	~MP E 4			
061805_18	~MP E 4	~MP E 3			t~75, 245 SMALL AMOUNT OF ACTIVITY ON WABTEC/SAB-WABCO DISC DURING BRAKING
061805_19	~MP E 3	NY Penn Station			
061805_20	NY Penn Station	MP AN 8			Little of Interest
061805_21	MP AN 8	Newark Station			GPS Issue in File, Nothing of Interest
061805_22	Newark Station	MP AN 22			t~210 LARGE OSCILLATION OF WABTEC/SAB-WABCO DISC DURING BRAKING (Sound Recording Made)
					t~445 LARGE OSCILLATION OF WABTEC/SAB-WABCO DISC (SHORT) DURING BRAKING (Sound Recording Made)
061805_23	MP AN 22	~MP AN 41			t~690, End of File BRAKE APPLICATION w/NO ACTIVITY
061805_24	~MP AN 41	~MP AN 58			t~305 FS BRAKE APPLICATION FROM 135 MPH, NO ACTIVITY
					t~570 FS BRAKE APPLICATION FROM 135, ACTIVITY DID NOT START UNTIL I'LOCK HIT PREVIOUS BRAKE APPLICATION NOT ACTIVE AND DID SEE VERTICAL HIT BEFORE??
061805_25	~MP AN 58	~MP AN 82.5			t~100 FS BRAKE APPLICATION FROM 125 MPH, NO ACTIVITY
					MANY BRAKE APPLICATIONS W/NO ACTIVITY
061805_26	~MP AN 82.5	Philadelphia Station			t~210 Brake Application w/No Activity
061805_27	Philadelphia Station	Philadelphia South			GPS Failure, No Activity of Interest
061805_28	Philadelphia South	Wilmington Car Shop			t~0-250 Much Lateral Activity
					t~290 Braking w/No Activity
					t~500 MUCH VERTICAL & LATERAL ACTIVITY
					t~600 VERTICAL ACTIVITY
061805_29	Wilmington Station	~MP AP 52			Some Saturation of vertical accels observed
					t~340 FS BRAKE APPLICATION FROM 135mph, NO ACTIVITY

Acela Brake Disc Test - Test Log

Date 18-Jun-05
 Test Run Boston-Washington, 9-inch Cant Deficiency Speed Profile
 Train Configuration Cars 3413, 3534 on Lead of Consist (PC 2038 Leading) to Washington
 Sample Rate 3000 samples/sec
 Anti-Alias Filter Setting Set to 800 Hz, Calculated at 750 Hz
 Header File Used sample3000_65r5.hed

3kHz (65 ch) System

Filename (*AB3, *.CAL, *.GPS)	Start Location	End Location	Track (if avail)	Channel List/Settings	Comments
061805_30	~MP AP 52	~MP AP 78			t~80 BIG VERTICAL HIT t~180 BRAKING w/NO ACTIVITY t~220 BIG VERTICAL ACTIVITY t~730 BIG VERTICAL HIT @ EDGEWOOD I'LOCK t~780 SMALL BIT OF VERTICAL ACTIVITY DURING BRAKING FOLLOWING VERTICAL HIT t~630 BIG VERTICAL HIT
061805_31	~MP AP 78	Baltimore Station			

END OF TESTING

Sound Files

Filename	Start Location
061805_01.WAV	~MP AN14
061805_02.WAV	~MP AN19

Daily Reports

The following reports were provided to test participants by Knorr-Bremse, usually on the same day as the test. There was usually not sufficient time to verify extreme data values cited in the daily reports prior to their dissemination.

These reports are provided for historical reference only. Values cited in the final report should be considered as verified and accurate.

Please note that no daily report was issued following the test conducted on May 27, 2005.

From: Rich.Bowie@knorrbrakecorp.com
Sent: Wednesday, May 18, 2005 10:34 AM
To: Ronald.Newman@fra.dot.gov; edlombardi@comcast.net; nbehety@necmsc.com; frank.duschinsky@ca.transport.bombardier.com; schramd@amtrak.com
Cc: GAGARIG@amtrak.com; Magdy.El-Sibaie@fra.dot.gov; JWhite@Wabtec.com; bjoern.neller@faiveleytransport.com; Bernd.Hetterscheidt@faiveleytransport.com
Subject: RE: Summary of Test Train Results 5/16/05

Dear Mr. Newman,

As you requested, following is a summary of the test results from today and instrumentation status.

1. The rotating axle mounted accelerometer was inspected and re-tightened en-route from Boston. Performing properly now.

2. Aliasing frequency was increased to 1000 Hz with sampling at 4000 Hz initially, but was needed to be changed to 1000 Hz filter with 3000 Hz sampling.

3. Thermocouple was added to the back side of the friction ring and replaced spoke thermocouple on the data acquisition.

We observed the following data from the test runs:

Maximum rotor temperatures were observed during the test run were within acceptable limits. We observed maximum rotor temperatures of about 258 F, with an average peak of 200 F. (No Full-Service Stops were performed). Adding 100 degrees for correction factor has the discs temperature within expected and acceptable results. Spoke temperatures were reported to be in the range of less than 150 F. Allowing for a correction factor that is to be determined, they are Still within acceptable limits.

Maximum measured temp on back of the friction face was 275 F

For the accelerations, we noted the following peak values from the charts (detailed evaluation of the data will be conducted shortly):

Location:	Direction	Maximum
Left Axle Box	Vertical	117
Left Axle Box	Lateral	38

Right Axle Box	Vertical	99
Right Axle Box	Lateral	73
Rotating Axle	Lateral	30; however values in excess of 200 recorded. This must be evaluated further.

The values recorded all seem to coincided well with each other. We believe to have recorded accurate data that is within acceptable results.

Spoke Strains were monitored and found to be in the range of what was observed during the shakedown run. Today we observed peak values of approximately 2400 uE as compared to approximately 2000uE in the shakedown run.

These data values need to be validated by Ensco and considered further.

Best Regards,

Richard Bowie
Director of Engineering

Knorr Brake Corp.
861 Baltimore Blvd.
Westminster, MD 21157
Phone +(410) 875-1251
Fax +(410) 875-9053

< <mailto:rich.bowie@knorrbrakecorp.com>
mailto:rich.bowie@knorrbrakecorp.com>

< <http://www.knorrbrakecorp.com/> http://www.knorrbrakecorp.com>

< <http://www.knorr-bremse.com/> http://www.knorr-bremse.com/>

From: Rich.Bowie@knorrbrakecorp.com
Sent: Wednesday, May 18, 2005 10:28 PM
To: Ronald.Newman@fra.dot.gov; edlombardi@comcast.net; nbehety@necmsc.com; frank.duschinsky@ca.transport.bombardier.com; schramd@amtrak.com
Cc: GAGARIG@amtrak.com; Magdy.El-Sibaie@fra.dot.gov; JWhite@Wabtec.com; bjoern.neller@faiveleytransport.com; Bernd.Hetterscheidt@faiveleytransport.com; jquigley@faiveleyrail.com
Subject: RE: Summary of Test Train Results 5/17/05

Dear Sirs,

First, please note that the original email had not updated the date reported in the "Subject" Line to be 5/17/05. This has now been corrected.

Please find below an update to the prior report to include the data reported by NEC from the MPI inspection of TS 10 after the Boston-Washington test run 5/17/05.

Car	Axle	S/n disc	location	Spoke#
Was	Now			
3306	3	062/J5713	G	1
W0	W0			
2		W1	S1	
3		W2	S3	
4		W1	W1	
5		W1	W1	
6.		W0	W0	
			C	
ALL		NO CHANGES		
			S	1
W0	W0			
2		W0	W2	
3		W2	S1	
4		W2	W2	
5		W0	W0	
6.		W2	W2	

This axle has been replaced.

Rich

-----Original Message-----

From: Bowie, Rich
 Sent: Wednesday, May 18, 2005 10:34 AM
 To: 'Newman, Ronald'; 'Ed Lombardi'; 'Norbert Behety'; 'Frank Duschinsky'; 'David Schramm'
 Cc: 'GAGARIG@amtrak.com'; 'El-Sibaie, Magdy'; 'JWhite@Wabtec.com'; 'bjoern.neller@faiveleytransport.com'; 'Bernd.Hetterscheidt@faiveleytransport.com'
 Subject: RE: Summary of Test Train Results 5/16/05

Dear Mr. Newman,

As you requested, following is a summary of the test results from today and instrumentation status.

1. The rotating axle mounted accelerometer was inspected and re-tightened en-route from Boston. Performing properly now.
2. Aliasing frequency was increased to 1000 Hz with sampling at 4000 Hz initially, but was needed to be changed to 1000 Hz filter with 3000 Hz sampling.
3. Thermocouple was added to the back side of the friction ring and replaced spoke thermocouple on the data acquisition.

We observed the following data from the test runs:

Maximum rotor temperatures were observed during the test run were within acceptable limits. We observed maximum rotor temperatures of about 258 F, with an average peak of 200 F. (No Full-Service Stops were performed). Adding 100 degrees for correction factor has the discs temperature within expected and acceptable results. Spoke temperatures were reported to be in the range of less than 150 F. Allowing for a correction factor that is to be determined, they are Still within acceptable limits.

Maximum measured temp on back of the friction face was 275 F

For the accelerations, we noted the following peak values from the charts (detailed evaluation of the data will be conducted shortly):

Location:	Direction	Maximum
Left Axle Box	Vertical	117
Left Axle Box	Lateral	38
Right Axle Box	Vertical	99
Right Axle Box	Lateral	73
Rotating Axle	Lateral	30; however values in excess of 200 recorded. This must be evaluated further.

The values recorded all seem to coincided well with each other. We believe to have recorded accurate data that is within acceptable results.

Spoke Strains were monitored and found to be in the range of what was observed during the shakedown run. Today we observed peak values of approximately 2400 uE as compared to approximately 2000uE in the shakedown run.

These data values need to be validated by Ensco and considered further.

Best Regards,

Richard Bowie
Director of Engineering

Knorr Brake Corp.
861 Baltimore Blvd.
Westminster, MD 21157
Phone +(410) 875-1251
Fax +(410) 875-9053

<mailto:rich.bowie@knorrbrakecorp.com>
mailto:rich.bowie@knorrbrakecorp.com>
<http://www.knorrbrakecorp.com/> http://www.knorrbrakecorp.com>
<http://www.knorr-bremse.com/> http://www.knorr-bremse.com/>

From: Dave.Welly@knorrbrakecorp.com
Sent: Thursday, May 26, 2005 6:42 PM
To: Ronald.newman@fra.dot.gov
Cc: edlombardi@comcast.net; Rich.Bowie@knorrbrakecorp.com
Subject: FW: Summary of Test Train Results 5/26/05

Dear Mr. Newman,

As you requested, the following is reported regarding today's test run from Washington to Boston.

Upon departure from Washington, no discs were reported to have cracks. After completion of the visual inspection in Boston this evening, a summary will be provided at the 10:00 p.m. conference call.

All instrumentation worked as expected, and no changes/modifications were required during the trip to Boston.

We observed the following data from the test runs:

Maximum rotor temperatures were observed during the test run were within acceptable limits. We observed maximum rotor temperatures of about 300 F, with an average peak of 200 F. Adding 100 degrees for correction factor has the discs temperature within expected and acceptable results.

For the accelerations, we noted to following peak values by observing real time data on the displays:

Location:	Direction	Maximum
Left Axle Box	Vertical	>100
Left Axle Box	Lateral	40
Right Axle Box	Vertical	>100
Right Axle Box	Lateral	40
Rotating Axle	Lateral	40

The values recorded all seem reasonable and coincided well with each other. We believe to have recorded accurate data that is within acceptable results.

Spoke strains were monitored and found to be in the range of what was observed during the first test run. Today we observed peak values of approximately 2100 uE. The highest peak strains were noted to occur when entering suppression from approximately 120 mph. Values of this magnitude were noted just prior to Newark and then further North as well. The strains are within the expected and allowable ranges.

In summary, results were within acceptable range and are believed to be valid.

There is nothing noted that is of concern. Knorr recommends that the testing schedule for tomorrow be conducted as planned.

From: Dave.Welly@knorrbrakecorp.com
Sent: Friday, June 03, 2005 10:50 AM
To: Ronald.newman@fra.dot.gov
Cc: edlombardi@comcast.net; Rich.Bowie@knorrbrakecorp.com
Subject: RE: Summary of Test Train Results 5/26/05

Ron,

As you requested, below is the disc test inspection results following the 5/27 run from Boston to Washington.

Car Now	Axle	S/n disc	Location	Spoke#	Was
3413 ---	4	067J6642 W1	c	1	
3214 ---	4	095J6642 W1	c	1	
3214 ---	4	095J6642 W1	c	4	
3214 ---	4	078J6642 W1	c	6	
3214 ---	3	078J6642 W1	c	5	

Please let me know if you have any questions.

From: Rich.Bowie@knorrbrakecorp.com
Sent: Thursday, June 16, 2005 10:06 PM
To: SchramD@amtrak.com; Magdy.El-Sibaie@fra.dot.gov; edlombardi@comcast.net; frank.duschinsky@ca.transport.bombardier.com; Ronald.Newman@fra.dot.gov
Cc: Dave.Welly@knorrbrakecorp.com; Terry.Welsh@knorrbrakecorp.com; Joe.DeStefano@knorrbrakecorp.com; Mike.Kmon@knorrbrakecorp.com; Frank.Guenther@knorr-bremse.com; Christian.Witzleben@knorr-bremse.com; Sherrock.Eric; Kesler.Kevin; Whitten.Brian; JWhite@Wabtec.com; BjoernNeller@t-online.de; jquigley@faiveleyrail.com
Subject: Summary of Test Train Results 6/16/05

Dear Mr. Newman,

As you requested, the following was reported regarding the status of the disc inspection:

No changes to spoke inspection status except:

Car	Axle	S/n disc	location	Spoke#	Was
Now					
4214	4		c		4
W1	W0	(this will be noted in case it re-appears in Boston)			

The following is a summary of the instrumentation status.

1. GPS did not function for the duration of the trip and may not be functional for the trip
2. Two strain gauges on the Knorr disc (Strain gauges 4 and 5) appear to be damaged and may not be functional for the trip. These were noted as not being critical for evaluation of the disc for bending. They were added to get some information about the stresses from thermal expansion. Data collected from today's run should be adequate.

We observed the following data from the test runs:

Maximum rotor temperatures were observed during the test run were within acceptable limits. We observed maximum rotor temperatures of approximately 300F, with an average peak of 200F, measured on the back side of the friction face.

For the accelerations, we noted to following peak values from the charts:

Location:	Direction	Axle 1 Maximum
Axle 2 Maximum		
Left Axle Box	Vertical	100
100		
Left Axle Box	Lateral	40
>50		
Right Axle Box	Vertical	80
80		
Right Axle Box	Lateral	40
>50		
Rotating Axle	Lateral	>50
30		
TR Mounted Axle	Vertical	20
20		
Brake Mounted Axle	Vertical	10
15		

The values recorded all seem reasonable and coincided well with each

other. We believe to have recorded accurate data that is within acceptable results.

Spoke Strains were monitored and found to be in the range of what was observed previously. Today we observed peak values of approximately 2400 uE. The strains are within the expected and allowable ranges.

In summary, results were within acceptable range and are believed to be valid.

There is nothing noted that is of concern. Knorr recommends that the testing schedule for tomorrow be conducted as planned.

From: Dave.Welly@knorrbrakecorp.com
Sent: Friday, June 17, 2005 11:27 PM
To: Rich.Bowie@knorrbrakecorp.com; SchramD@amtrak.com; Magdy.El-Sibaie@fra.dot.gov; edlombardi@comcast.net; frank.duschinsky@ca.transport.bombardier.com; Ronald.Newman@fra.dot.gov
Cc: Terry.Welsh@knorrbrakecorp.com; Joe.DeStefano@knorrbrakecorp.com; Mike.Kmon@knorrbrakecorp.com; Frank.Guenther@knorr-bremse.com; Christian.Witzleben@knorr-bremse.com; Sherrock.Eric; Kesler.Kevin; Whitten.Brian; JWWhite@Wabtec.com; BjoernNeller@t-online.de; jquigley@faiveleyrail.com
Subject: Summary of Test Train Results 6/17/05

Dear Mr. Newman,

Disc inspection results will be reported during the 7:30 a.m. conference call on 6/18.

The following is a summary of the instrumentation status.

1. Strain gauge Axle2spk6_4 (on the Knorr disc) was inoperable during the run. This was discussed during the Thursday evening conference call and noted as acceptable to Knorr as this was a redundant gauge.

We observed the following data from the test runs:

Maximum rotor temperatures observed during the test run were within acceptable limits. We observed maximum rotor temperatures of approximately 220F, with an average peak of 150F, measured on the back side of the friction face.

For the accelerations, we noted to following peak values from the charts:

Location:	Direction	Axle 1 Maximum	Axle 2 Maximum
Left Axle Box	Vertical	80	100
Left Axle Box	Lateral	45	>50
Right Axle Box	Vertical	100	100
Right Axle Box	Lateral	>50	>50
Rotating Axle	Lateral	>50	25
TR Mounted Axle	Vertical	20	20
Brake Mounted Axle	Vertical	5	10

The values recorded all seem reasonable and coincided well with each other. We believe to have recorded accurate data that is within acceptable results.

Spoke Strains were monitored and found to be in the range of what was observed previously. Today we observed peak values of approximately 2200 uE. The strains are within the expected and allowable ranges.

In summary, results were within acceptable range and are believed to be valid.

There is nothing noted that is of concern. Knorr recommends that the testing schedule for tomorrow be conducted as planned.

From: Dave.Welly@knorrbrakecorp.com
Sent: Monday, June 20, 2005 1:24 PM
To: Ronald.Newman@fra.dot.gov; SchramD@amtrak.com; MurphyM@amtrak.com; GagariG@amtrak.com
Cc: Ed.Pritchard@fra.dot.gov; Rich.Bowie@knorrbrakecorp.com; Stephen.Carullo@fra.dot.gov; Harold.Blankenship@fra.dot.gov; Gary.Fairbanks@fra.dot.gov; George.Scerbo@fra.dot.gov; Satya.Singh@fra.dot.gov
Subject: Summary of Test Train Results 6/18/05

Dear Mr. Newman,

Disc inspection results from Saturday have not yet been reported.

The following is a summary of the instrumentation status.

1. Strain gauge Axle2spk6_4 (on the Knorr disc) was inoperable during the run. This was also inoperable during the 6/17 run from Washington to Boston.

We observed the following data from the test runs:

Maximum rotor temperatures observed during the test run were within acceptable limits. We observed maximum rotor temperatures of approximately 270F, with an average peak of 150F, measured on the back side of the friction face.

For the accelerations, we noted the following peak values from the charts:

Location:	Direction	Axle 1 Maximum
Axle 2 Maximum		
Left Axle Box 100	Vertical	100
Left Axle Box 25	Lateral	45
Right Axle Box 100	Vertical	100
Right Axle Box >50	Lateral	>50
Rotating Axle 25	Lateral	>50

TR Mounted Axle 20	Vertical	20
Brake Mounted Axle 10	Vertical	5

The values recorded all seem reasonable and coincided well with each other. We believe to have recorded accurate data that is within acceptable results.

Spoke Strains were monitored and found to be in the range of what was observed previously. Today we observed peak values of approximately 2600 uE. The strains are within the expected and allowable ranges.

In summary, results were within acceptable range and are believed to be valid.

There is nothing noted that is of concern.

Appendix E.

Finite Element Analysis Results

<u>Section</u>	<u>Page</u>
Natural Frequency and Spoke Strain Due to Mechanical Effects	E-4
Spoke Strain Due to Thermal Effects	E-19
Spoke Strain Due to Rotational Effects	E-25
Conclusions	E-28

Finite Element Analysis (FEA)

Considered WABTEC/SAB-WABCO Brake Disc

- Material Properties (Steel)
 - Modulus of Elasticity $E = 27.56 \times 10^6$ psi
 - Poisson's Ratio = 0.26
 - Density $\rho = 0.264$ lb/in³
- Finite Element Meshing
 - TET10 Midside Node Elements Used
 - 191700 Nodes In Model
- Considered Single, Unmounted Discs Only
 - No Compressive Stresses From Mounting Process Or Long-Term Use Accounted For

FEA

- Stress Analysis
 - Fixed Hub Mode
 - Free Mode
 - Heat Of Friction Plate $\sim \mu$ strain/degree
 - Rotation Rate Strain
- Fundamental (Natural) Frequencies
 - Fixed Hub Results: First Fundamental Frequency-206 Hz
 - Fixed Hub Results: Second Fundamental Frequency-267 Hz
 - Free Hub Results: First Fundamental Frequency-585 Hz

Natural Frequency and Spoke Strain Due to Mechanical Effects

Finite Element (FE) Solid Model

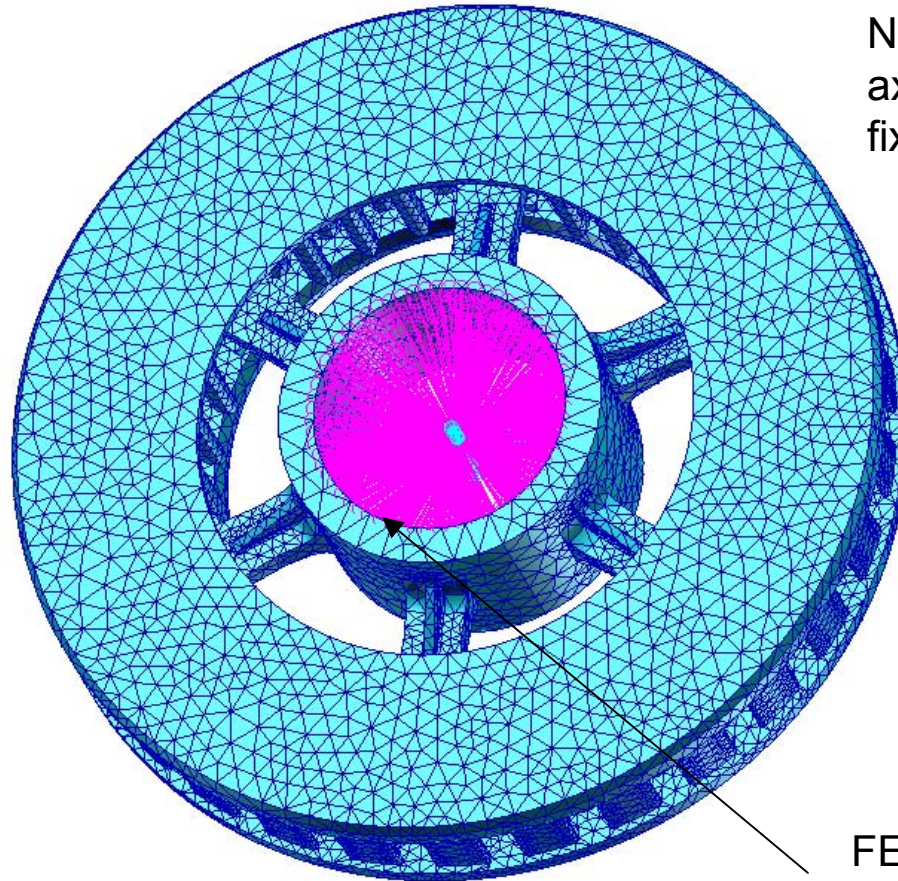

Nodes on inner surface of axle hole constrained for fixed frequency analysis.

FE constraints to axle center.

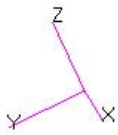

Table E.1. Natural Frequency Analysis:
ACELA Brake Rotor, Fixed Hub

Freq. (Hz)	Mode Shape
206	Disk rotates out-of-plane about hub
269	Disk translates out-of-plane about hub
645	Disk bends into saddle shape
799	Disk translates in-plane about hub

Note: For each of the above frequencies there were actually two modes at very slightly different frequencies, of identical shape but rotated with respect to each other.

FEA Modes of Vibration

1st Mode with Fixed Hub—206 Hz

MSC.Patran 2005 09-May-05 10:16:53

Deform: fixed_model, A2:Mode 1 : Freq. = 206., Eigenvectors, Translational,

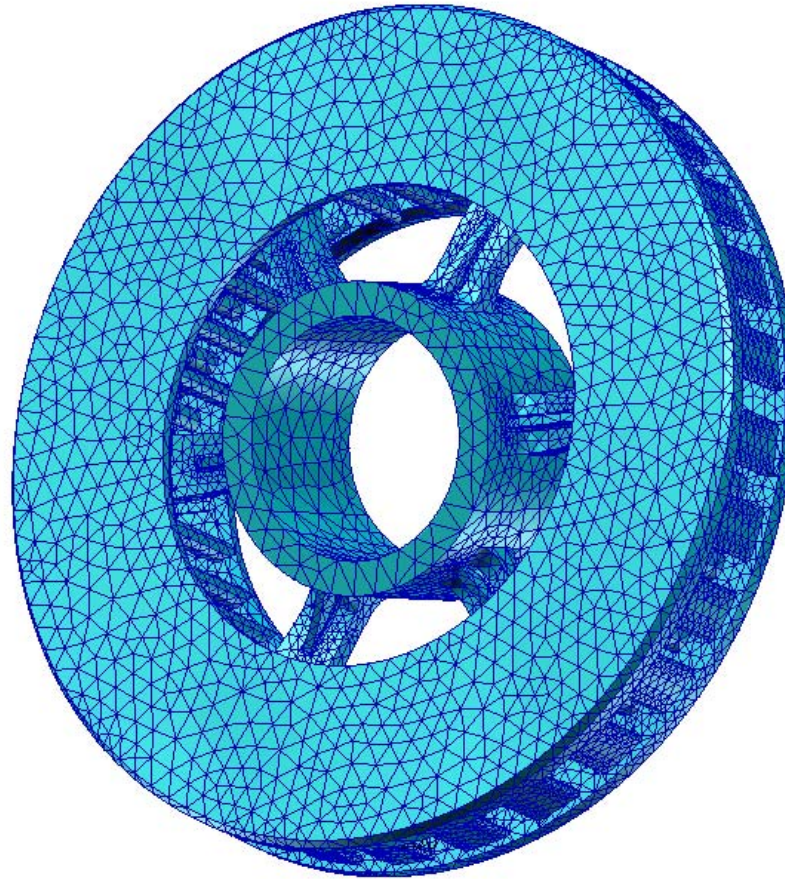

default_Deformation :
Max 2.26+000 @Nd 142861
Frame: 1
Scale = 1.00+000

FEA Modes of Vibration

1st Mode with Fixed Hub—206 Hz

ACELA Brake Rotor ver 6 FULL - new spoke - FEA-test1 :: Frequency
Mode Shape : 1 Value = 206.05 Hz Deformation Scale 1 : 0.434447

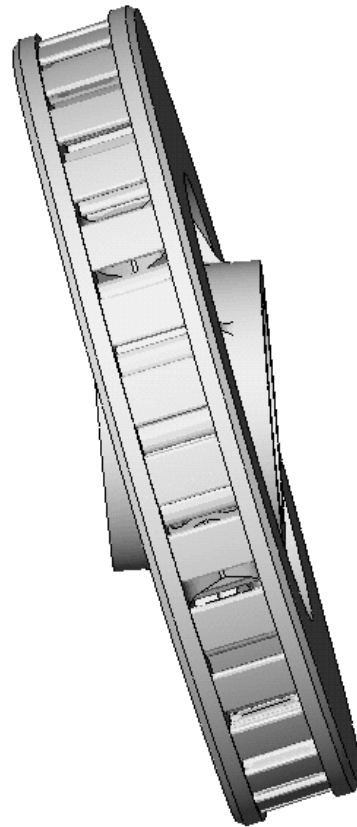

Out-of-
Plane
Bending
(BOP)
Mode

7

FEA Modes of Vibration

1st Mode with Fixed Hub—206 Hz

ACELA Brake Rotor ver 6 FULL - new spoke - FEA-test1 :: Frequency
Mode Shape : 1 Value = 206.05 Hz Deformation Scale 1 : 0.434447

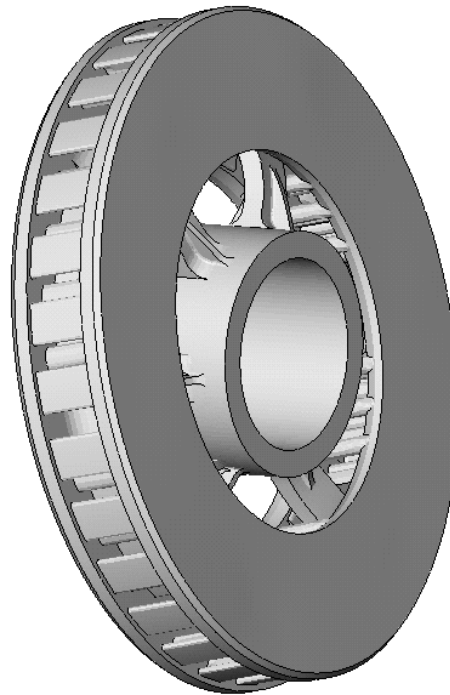

BOP Mode



FEA Modes of Vibration

1st Mode with Fixed Hub—206 Hz

ACELA Brake Rotor ver 6 FULL - new spoke - FEA-test1 :: Frequency
Mode Shape : 1 Value = 206.05 Hz Deformation Scale 1 : 0.434447

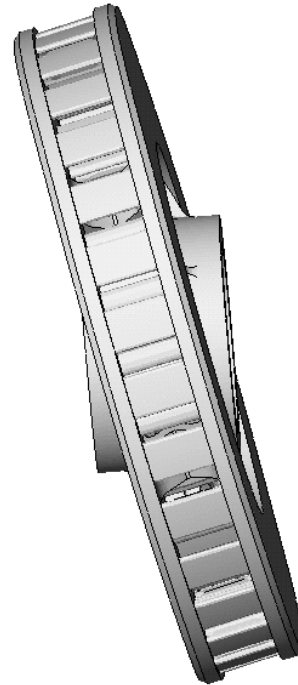

BOP Mode

FE Results—Fixed Hub Analysis, 1st Mode: 206 Hz

MSC.Patran 2005 09-May-05 12:40:29

Fringe: fixed_model, A2:Mode 1 : Freq. = 206., Strain Energy, Energy Density, (NON-LAYERED)

Deform: fixed_model, A2:Mode 1 : Freq. = 206., Eigenvectors, Translational,

Strain Energy Density
on Spoke

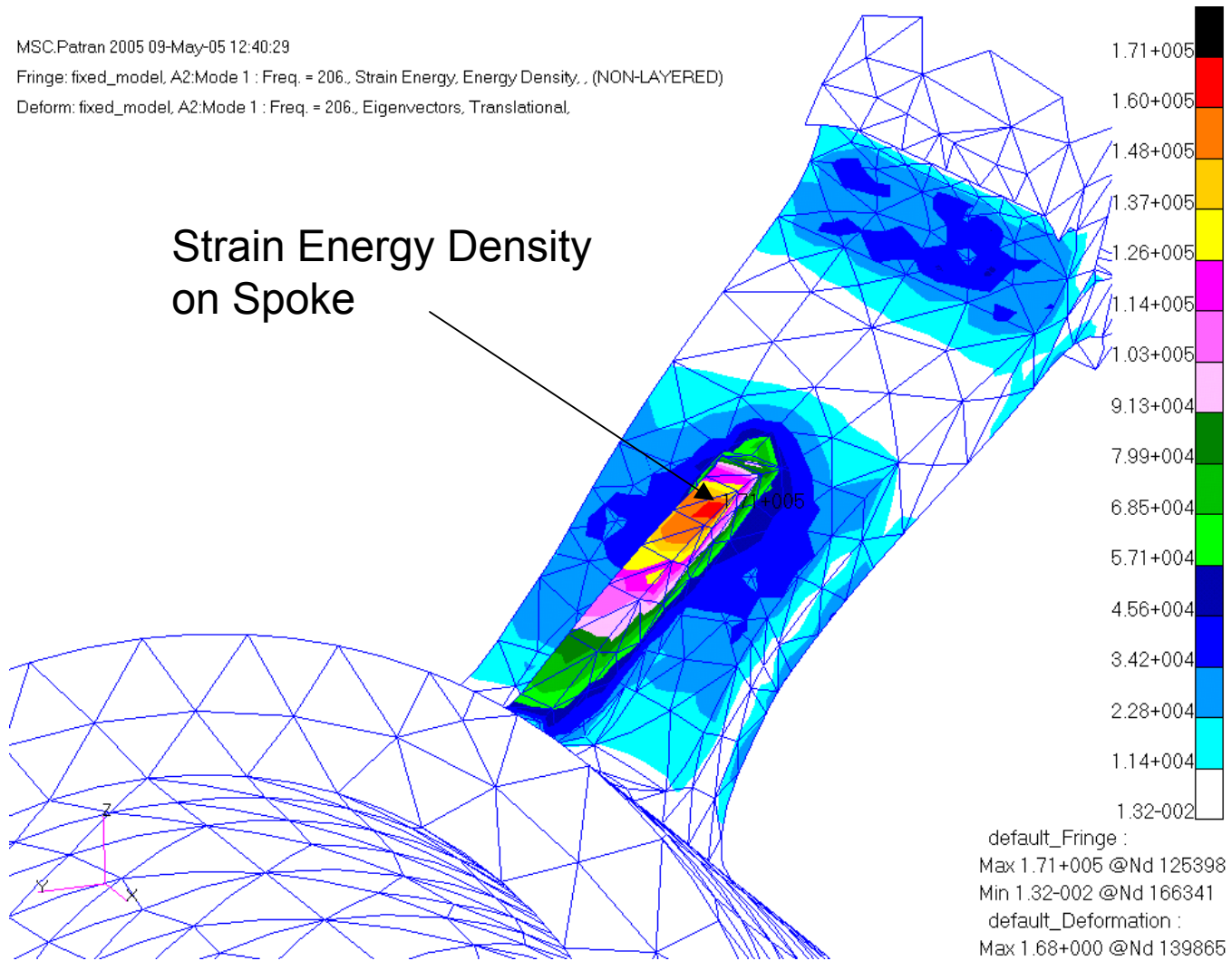

FEA Modes of Vibration

2nd Mode with Fixed Hub—269 Hz

MSC.Patran 2005 15-Jun-05 10:33:43

Deform: fixed_model, A1:Mode 4 : Freq. = 268.69, Eigenvectors, Translational.

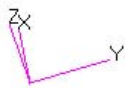
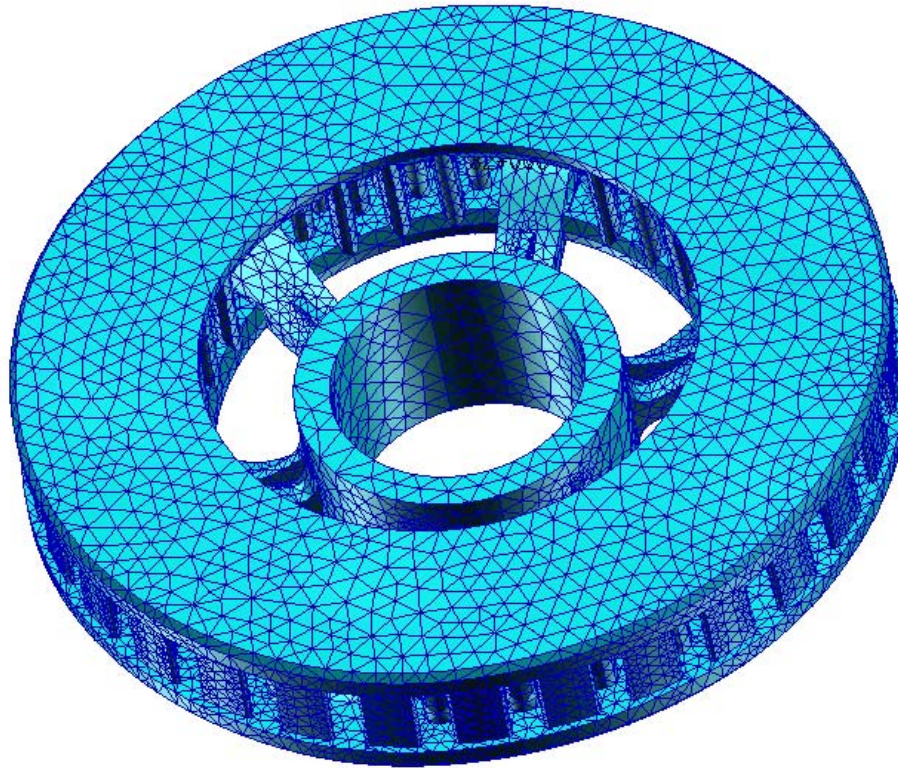

default_Deformation :
Max 1.32+000 @Nd 150305
Frame: 1
Scale = 1.00+000

FEA Modes of Vibration

3rd Mode with Fixed Hub—645 Hz

MSC.Patran 2005 15-Jun-05 10:38:21

Deform: fixed_model, A1:Mode 6 : Freq. = 644.92, Eigenvectors, Translational,

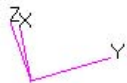
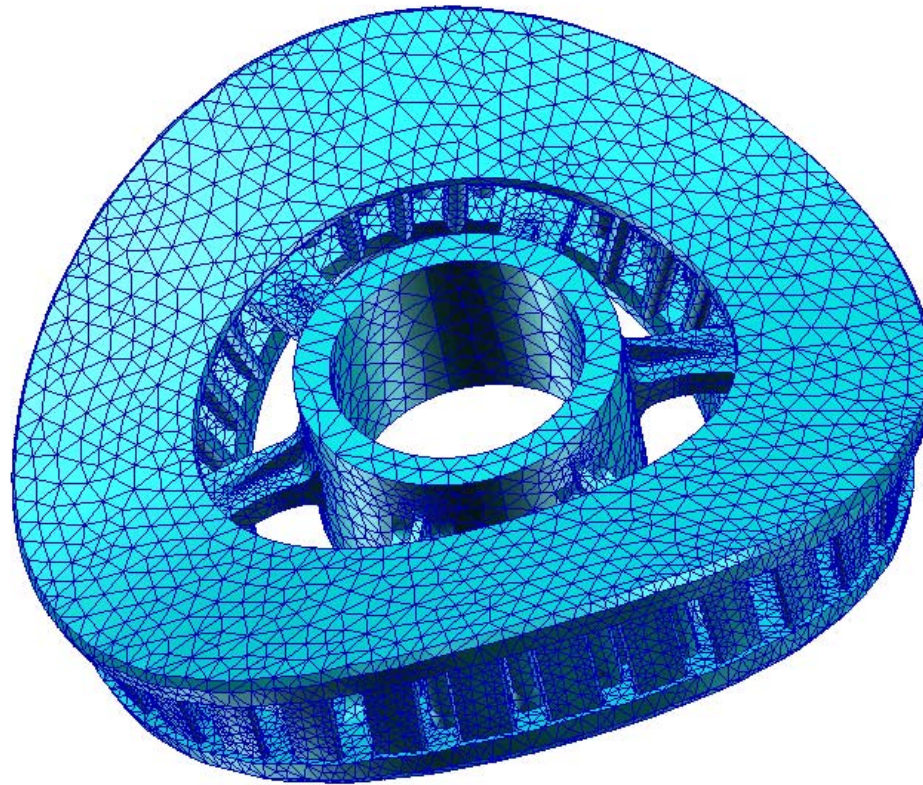

default_Deformation :
Max 2.45+000 @Nd 152820
Frame: 1
Scale = 1.00+000

FEA Modes of Vibration

4th Mode with Fixed Hub—799 Hz

MSC.Patran 2005 15-Jun-05 10:40:41

Deform: fixed_model, A1:Mode 8 : Freq. = 799.36, Eigenvectors, Translational.

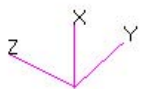
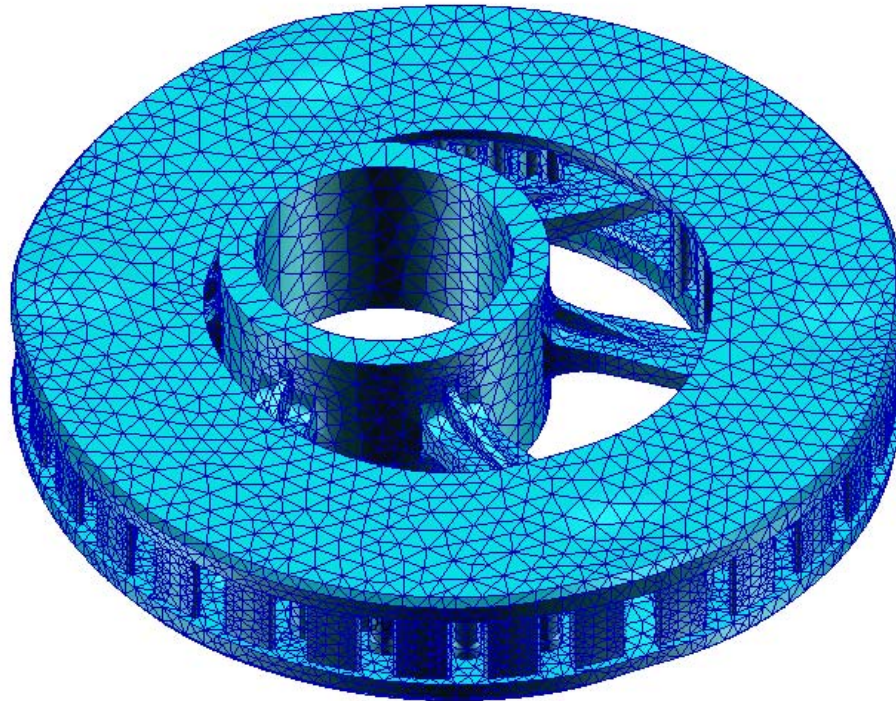

default_Deformation :
Max 1.38+000 @Nd 10595
Frame: 1
Scale = 1.00+000

FEA Modes of Vibration

1st Mode with Free Hub—585 Hz

MSC.Patran 2005 09-May-05 10:20:45

Deform: free_model, A1:Mode 7 : Freq. = 585.78, Eigenvectors, Translational,

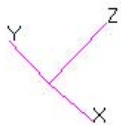
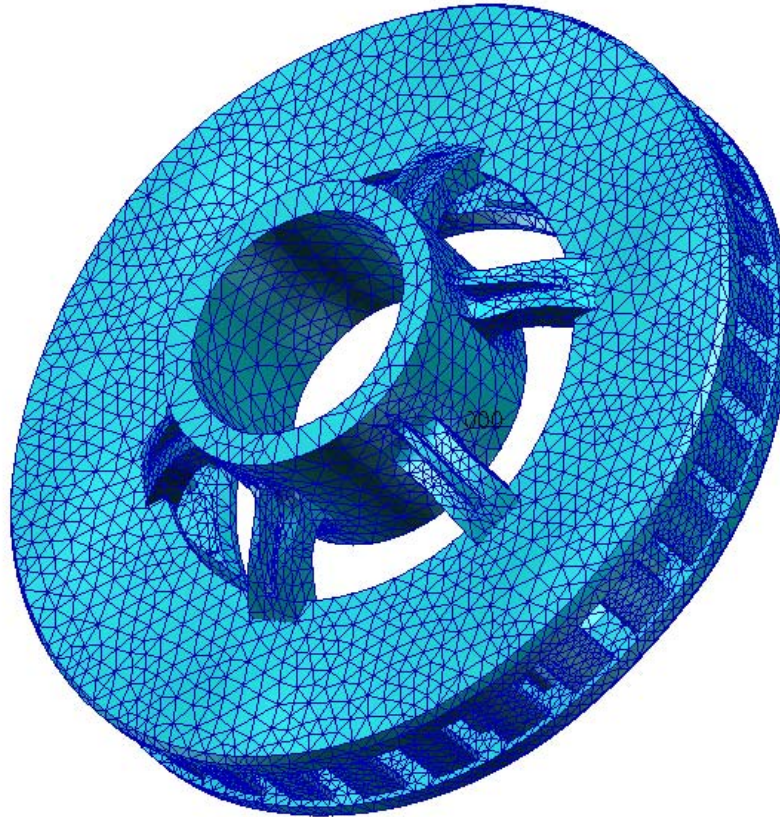

default_Deformation :
Max 2.34+000 @Nd 156964
Frame: 1
Scale = 1.00+000

FEA Modes of Vibration

1st Mode with Free Hub—585 Hz

MSC.Patran 2005 09-May-05 10:20:45

Fringe: free_model, A1:Mode 7 : Freq. = 585.78, Strain Energy, Energy Density, (NON-LAYERED)

Deform: free_model, A1:Mode 7 : Freq. = 585.78, Eigenvectors, Translational,

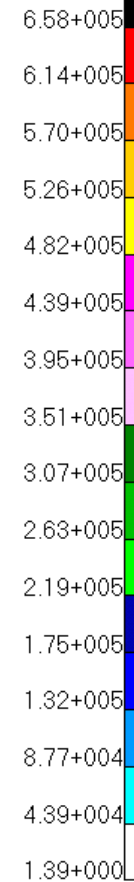
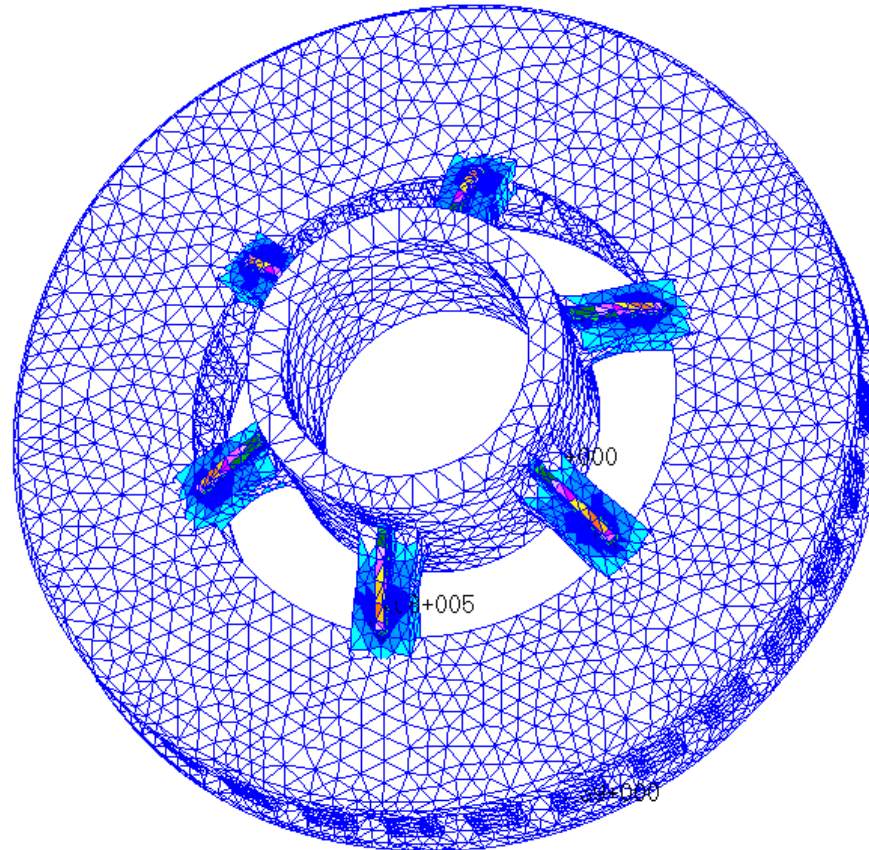
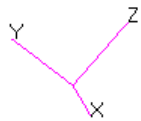

default_Fringe :
Max 6.58+005 @Nd 161732
Min 1.39+000 @Nd 148610
default_Deformation :
Max 2.34+000 @Nd 156964
Frame: 12
Scale = 8.66-001

FEA Modes of Vibration

1st Mode with Free Hub—585 Hz

MSC.Patran 2005 09-May-05 10:20:45

Fringe: free_model, A1:Mode 7 : Freq. = 585.78, Eigenvectors, Translational, Magnitude, (NON-LAYERED)

Deform: free_model, A1:Mode 7 : Freq. = 585.78, Eigenvectors, Translational,

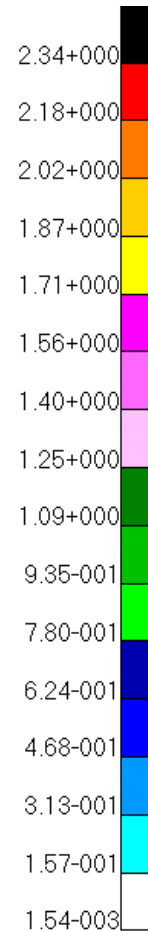
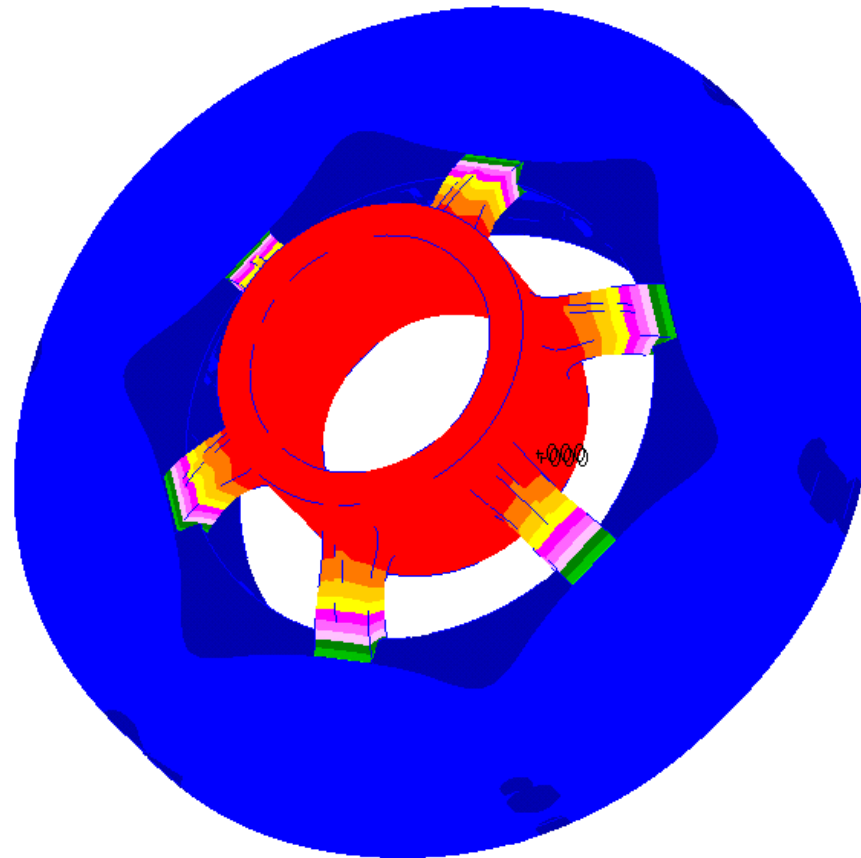

default_Fringe :
Max 2.34+000 @Nd 156964
Min 1.54-003 @Nd 34323

default_Deformation :
Max 2.34+000 @Nd 156964
Frame: 12
Scale = 8.66-001

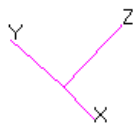

FE Results—Free Hub Analysis, 1st Mode: 585 Hz

MSC.Patran 2005 09-May-05 12:41:21

Fringe: free_model, A3:Mode 7 : Freq. = 585.78, Strain Energy, Energy Density, (NON-LAYERED)

Deform: free_model, A3:Mode 7 : Freq. = 585.78, Eigenvectors, Translational.

Strain Energy Density
on Spoke

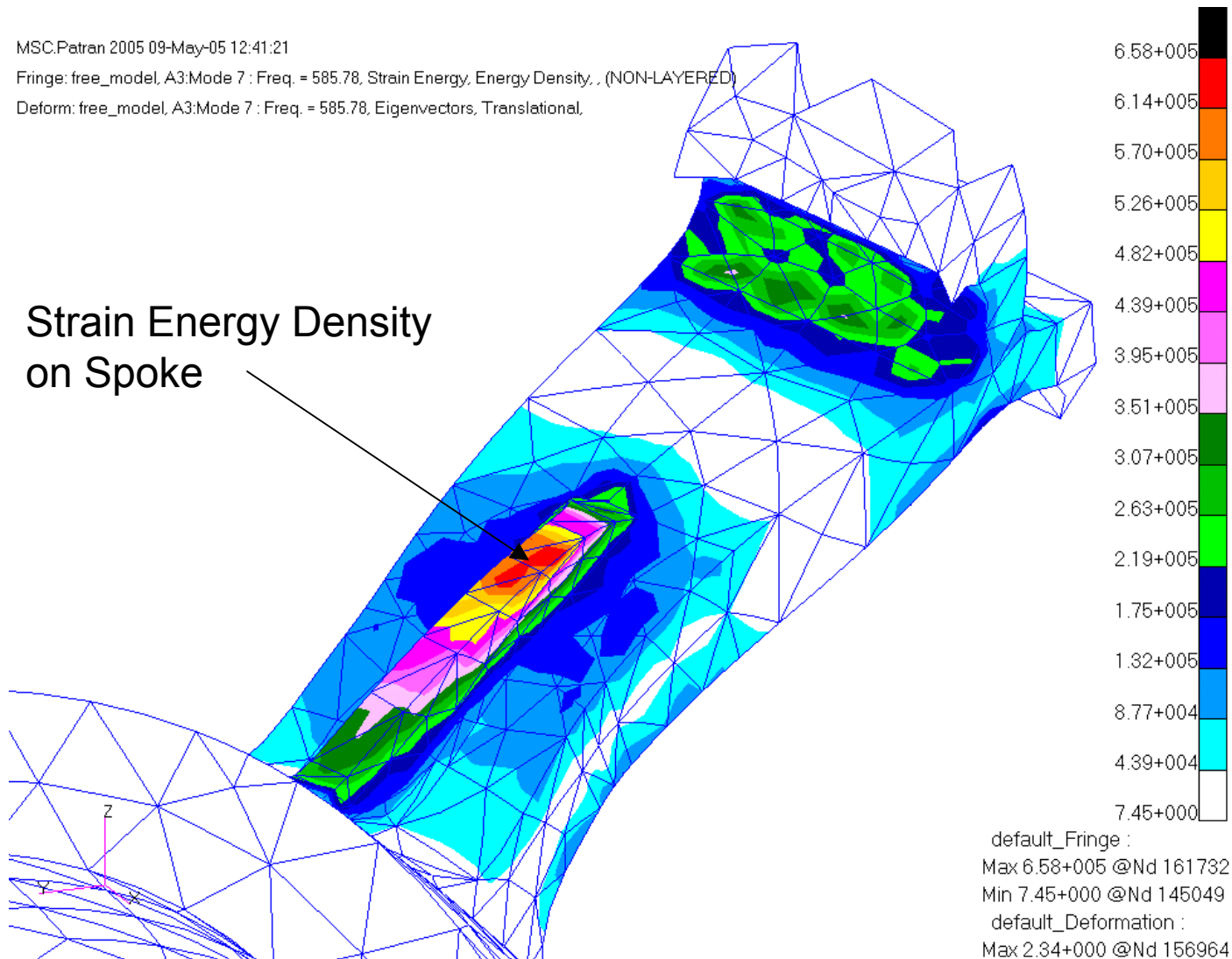

Spoke Strain Due to Thermal Effects

Thermal Stress Analysis

- Material Properties (Steel)
 - Modulus of Elasticity $E = 27.56 \times 10^6$ psi
 - Poisson's Ratio = 0.26
 - Density $\rho = 0.264$ lb/in³
- Temperatures
 - Assumed 70 °F (~Ambient Temperature) at Hub and 300 °F (Estimate of Temperature Resulting From Braking) at Braking Surface
- Mechanical Conditions
 - No External Loads or Rotation of the Disc

FEA: Thermal Conditions

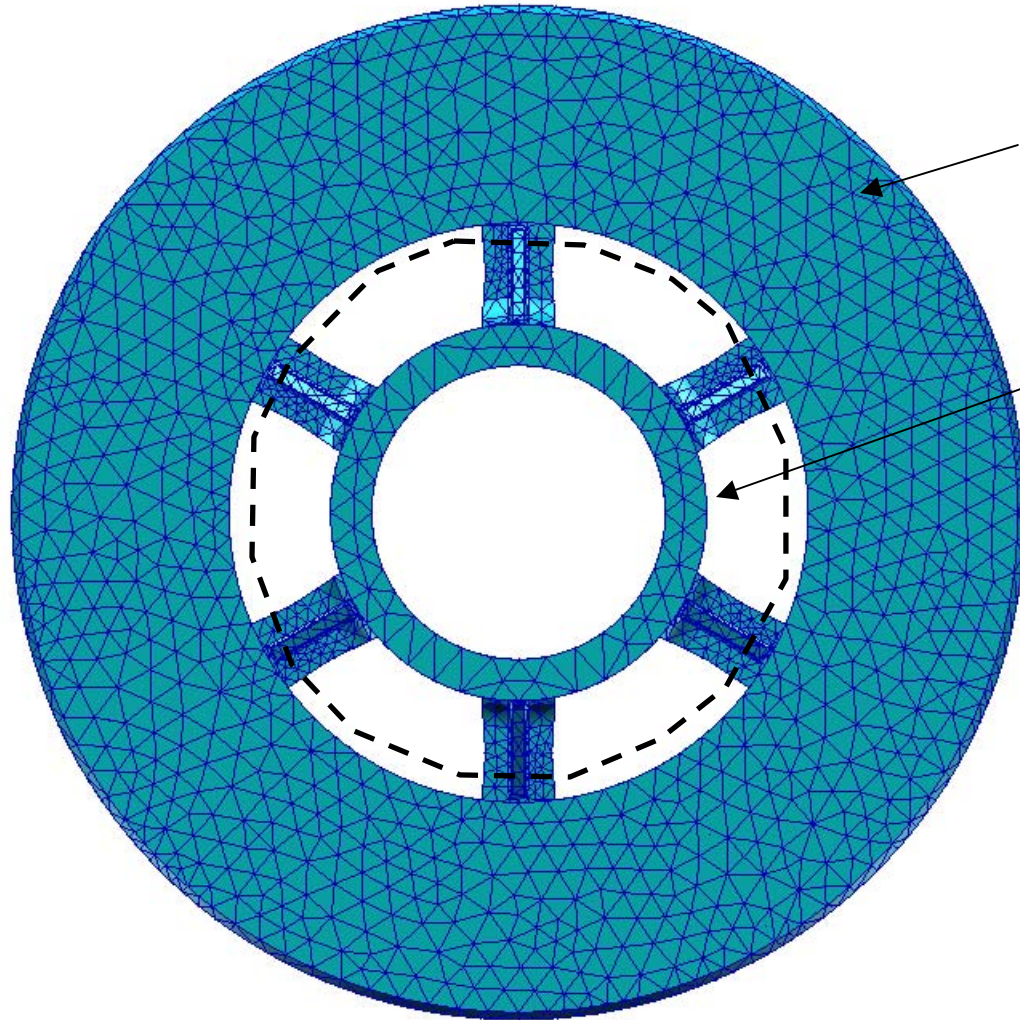

Temperature of the
outer faces and
connectors = 300°F

Temperature of
inner hub and
spokes = 70°F

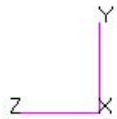

FEA: 300°F Thermal Spoke Stress (psi)

MSC.Patran 2005 09-May-05 15:45:39

Fringe: new_thermal, A4:Static Subcase, Stress Tensor, , von Mises, (NON-LAYERED)

Deform: new_thermal, A4:Static Subcase, Displacements, Translational,

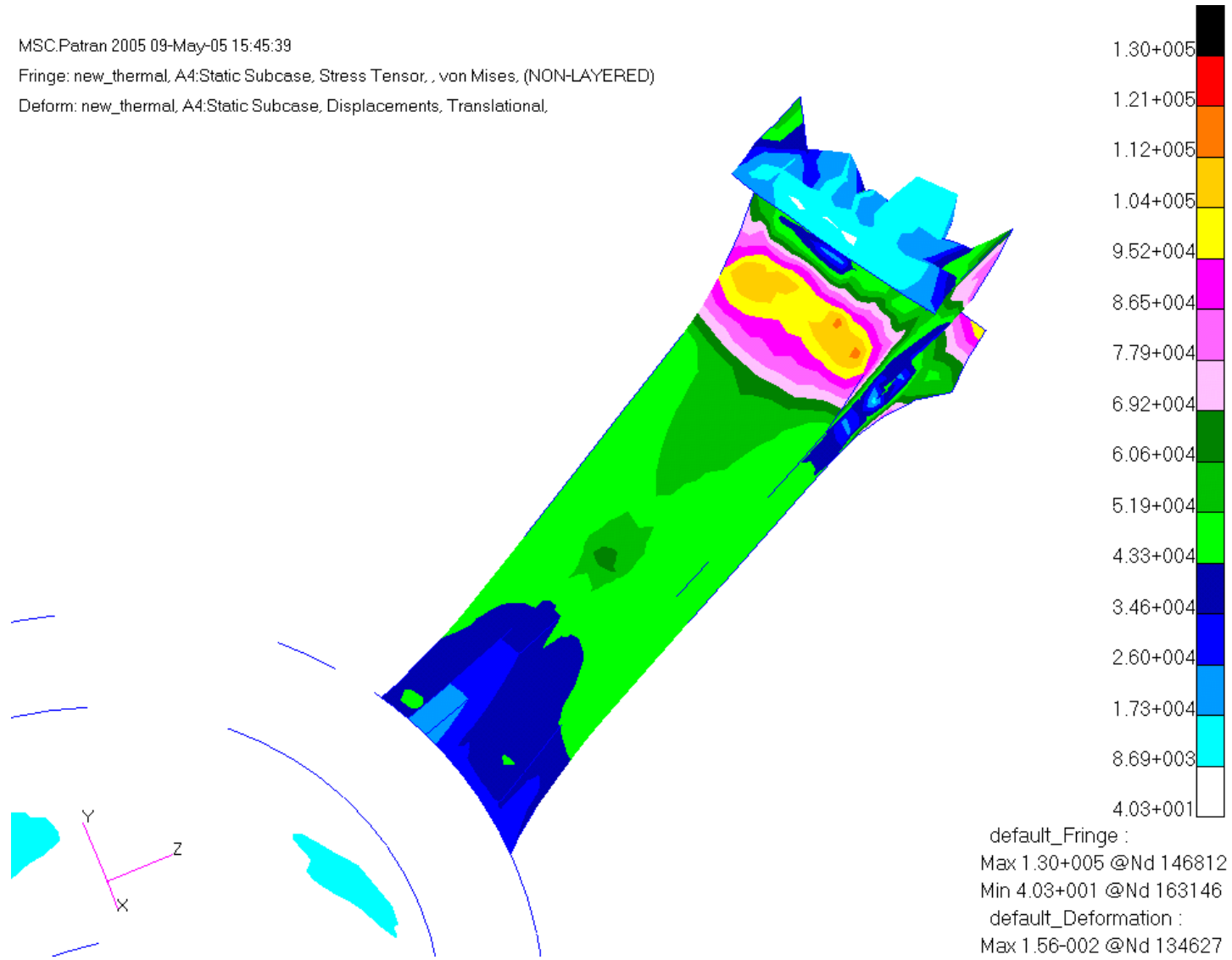

FEA: Thermal Stress on Spoke

MSC.Patran 2005 09-May-05 11:40:28

Fringe: thermal, A1:Static Subcase, Stress Tensor, , von Mises, (NON-LAYERED)



default_Fringe :
Max 1.09+004 @Nd 139856
Min 8.17+000 @Nd 163504

FEA: Spoke Strain Due to Thermal Effects

MSC.Patran 2005 24-May-05 15:51:14

Fringe: new_thermal, A2:Static Subcase, Strain Tensor, , (NON-LAYERED)

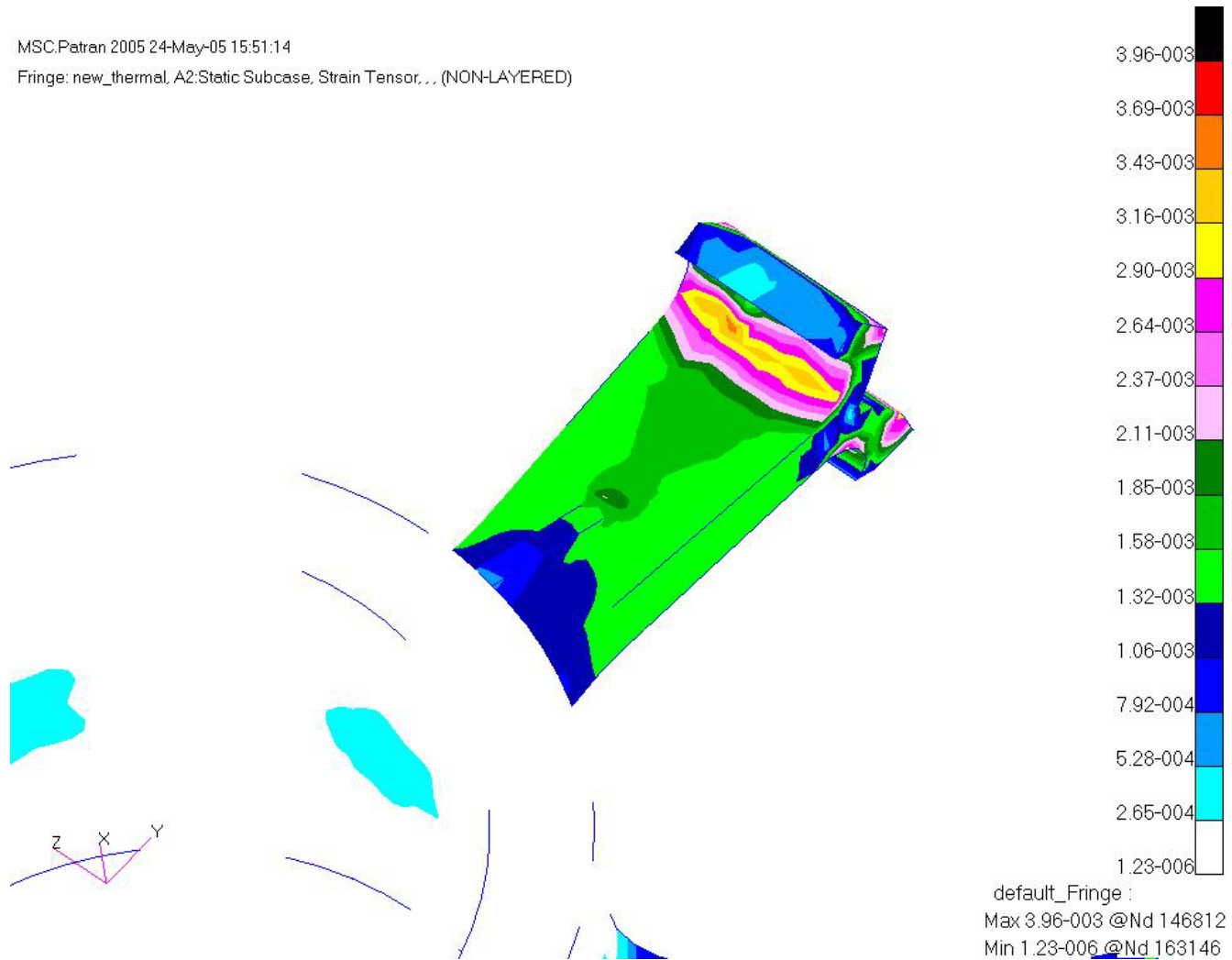

Spoke Strain Due to Rotational Effects

FEA: 1400 RPM Rotation

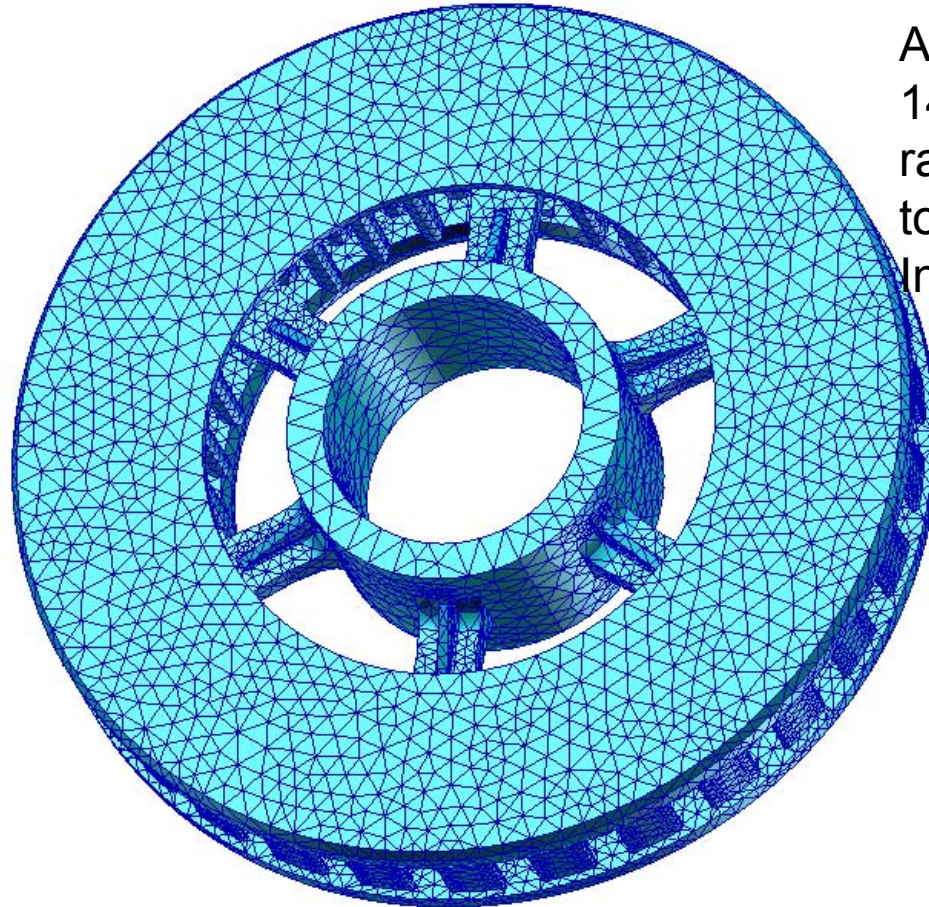

A rotation rate of 1400 RPM (146.6 rad/sec) is applied to the model as an Inertial Load.

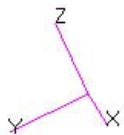

FEA: 1400 RPM Rotation Stress on Spoke (psi)

MSC.Patran 2005 10-May-05 14:18:04

Fringe: rotation, A1:Static Subcase, Stress Tensor, , von Mises, (NON-LAYERED)

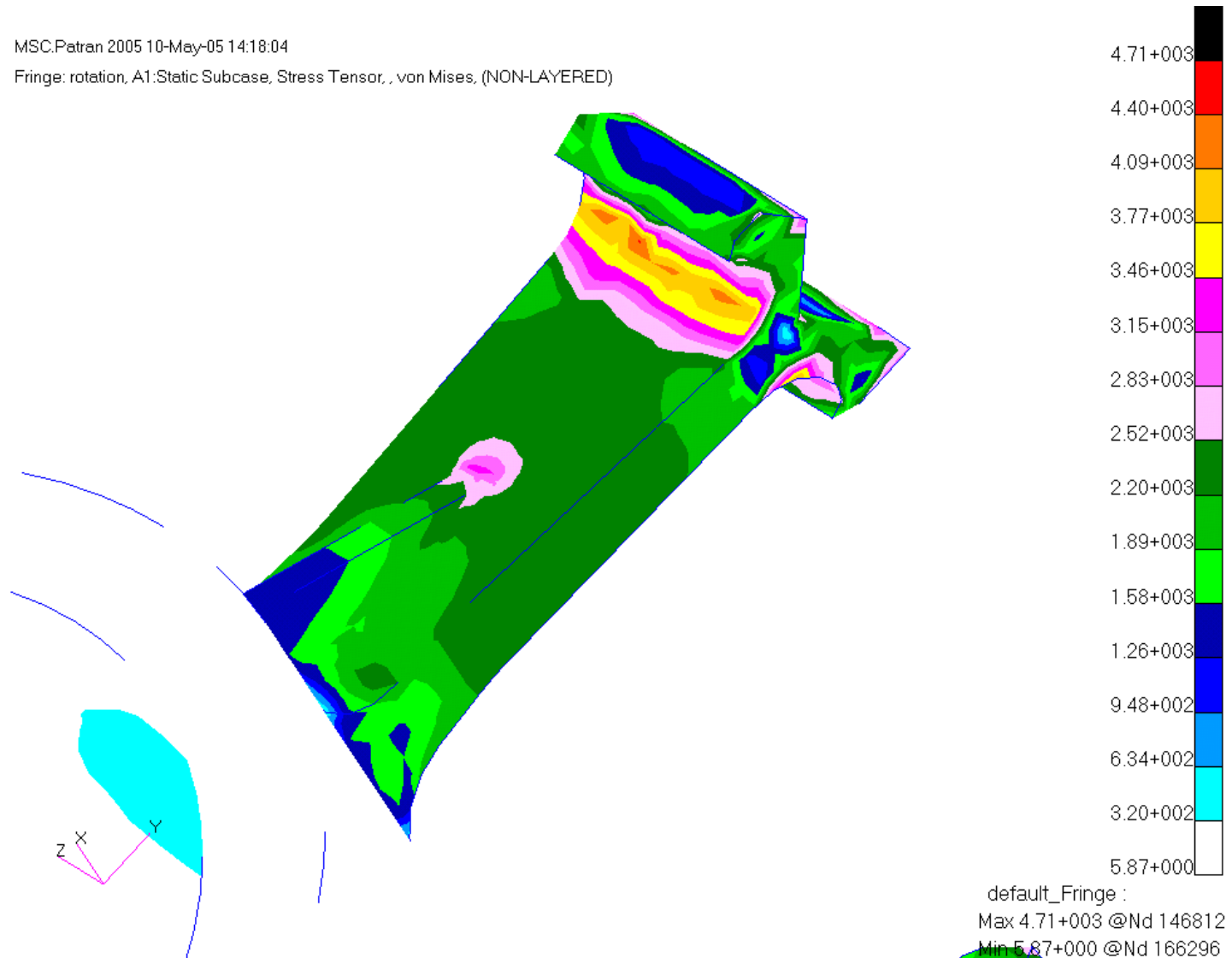

Conclusions

FEA Conclusions

- Predicts 206 Hz BOP Of Disc When The Hub Is Fixed
- Predicts A Hot Spot For Stress In BOP Mode At The General Location Of Observed Cracks
- Predicts Tensile Strain In Spokes Due To Temperature Rise In Friction Rings
- Predicts Low Strain In Spoke Due To Rotation

Appendix F. Accelerations

<u>Section</u>	<u>Page</u>
Axle Accelerations	F-2
Lateral Shocks	F-15
Vertical Shocks	F-18
Relationship of BOP Strain During Non-Braking Conditions to Acceleration Differences	F-33
Comparison of Response of WABTEC/SAB-WABCO and Knorr Brake Discs	F-49
Axle Acceleration Examples	F-53
Caliper Accelerations	F-66
Brake Mount Accelerations	F-79
Truck Accelerations	F-92
BOP Responses	F-105
Plots of Axle Vertical Accelerations Exceeding 100 G	F-110
Day 1–May 16, 2005	F-111
Day 2–May 17, 2005	F-117
Day 3–May 26, 2005	F-126
Day 4–May 27, 2005	F-143
Day 6–June 17, 2005	F-159
Day 7–June 18, 2005	F-197

Axle Accelerations

Lateral Acceleration (Lead)

Day 3 Accelerations (Peaks)

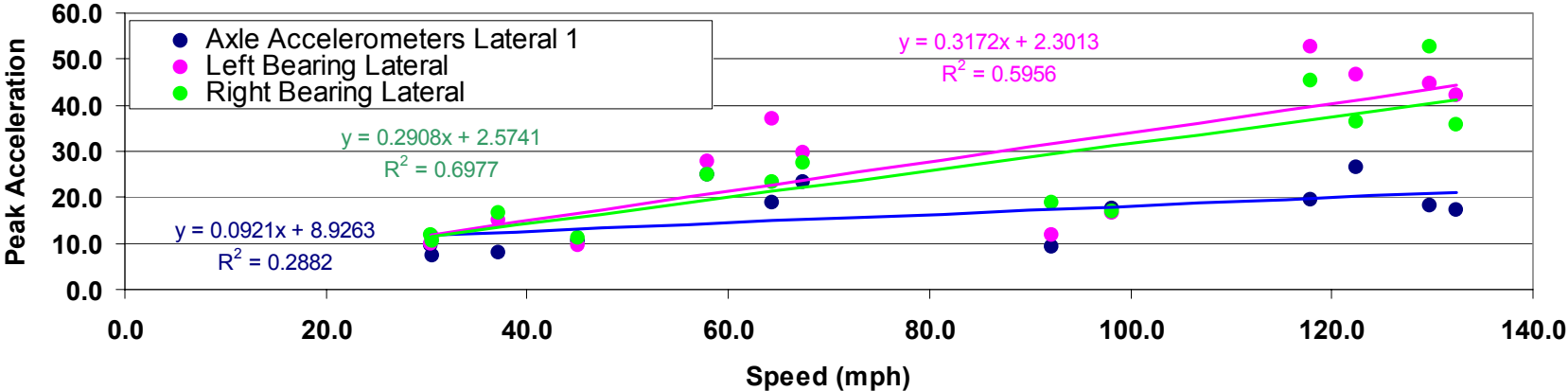

Day 3 Accelerations (99.9% Percentile)

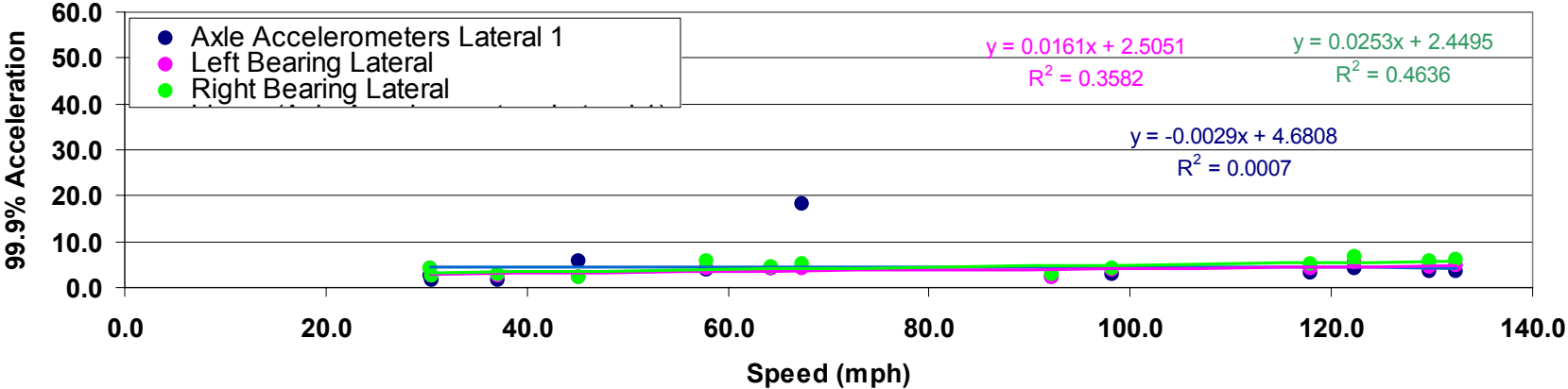

Vertical Acceleration (Lead)

Day 3 Accelerations (Peaks)

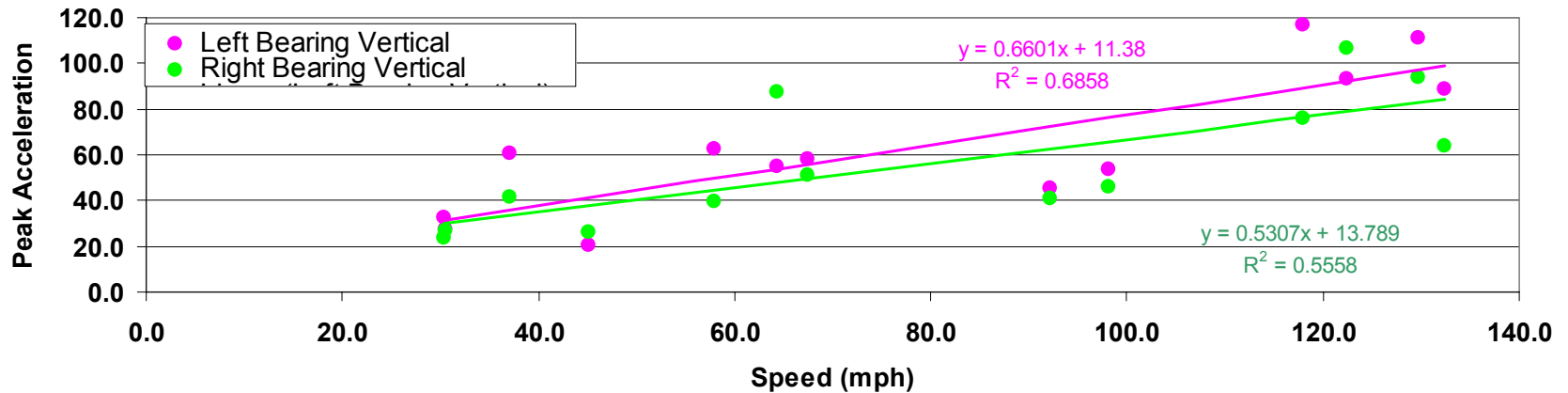

Day 3 Accelerations (99.9% Percentile)

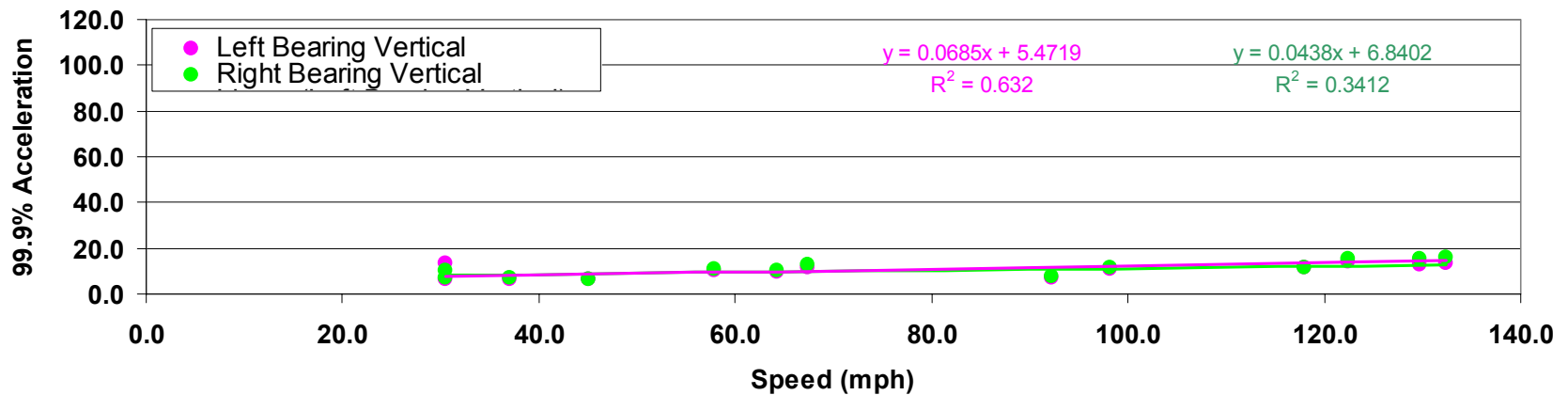

Conclusions–5/26/05

- The Car Tested With The Instrumented Axle In The Leading Position
- Accelerations Generally Increase With Speed
- Lateral Acceleration Measured On The Bearing Generally Higher Than On The Axle
- Axle Bearing System Peak Accelerations
 - Vertical Bearing–117 G's
 - Lateral Bearing–53 G's
 - Lateral Axle–26 G's

Lateral Acceleration (Trailing)

Day 4 Accelerations (Peaks)

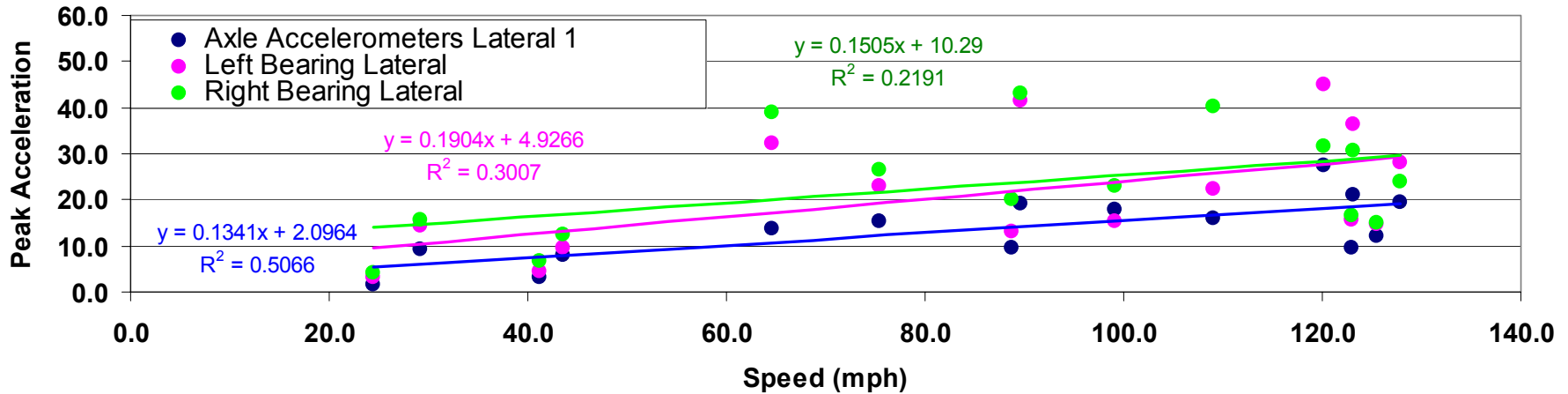

Day 4 Accelerations (99.9% Percentile)

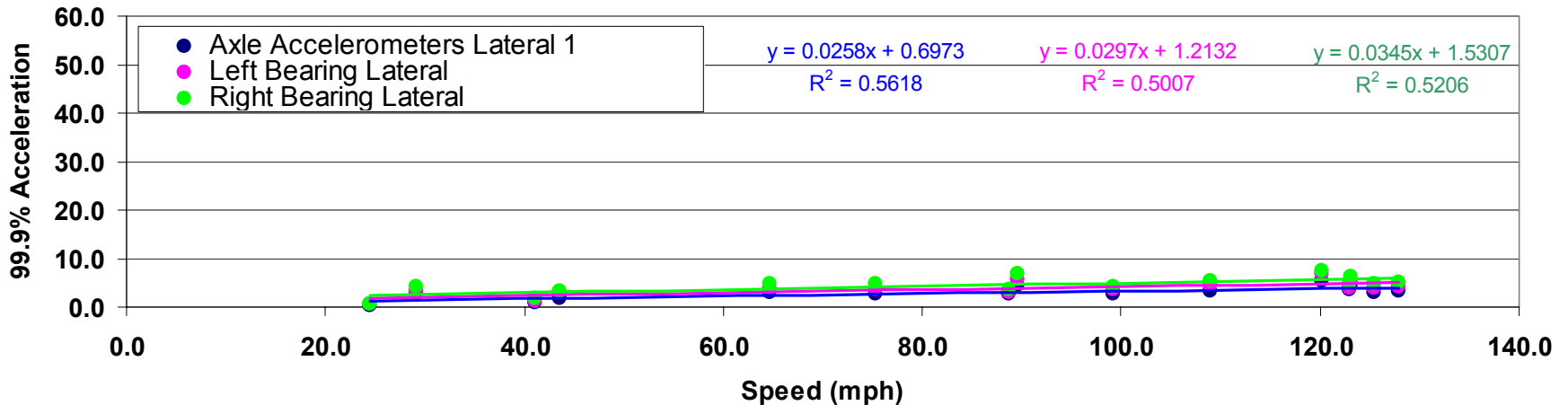

Vertical Acceleration (Trailing)

Day 4 Accelerations (Peaks)

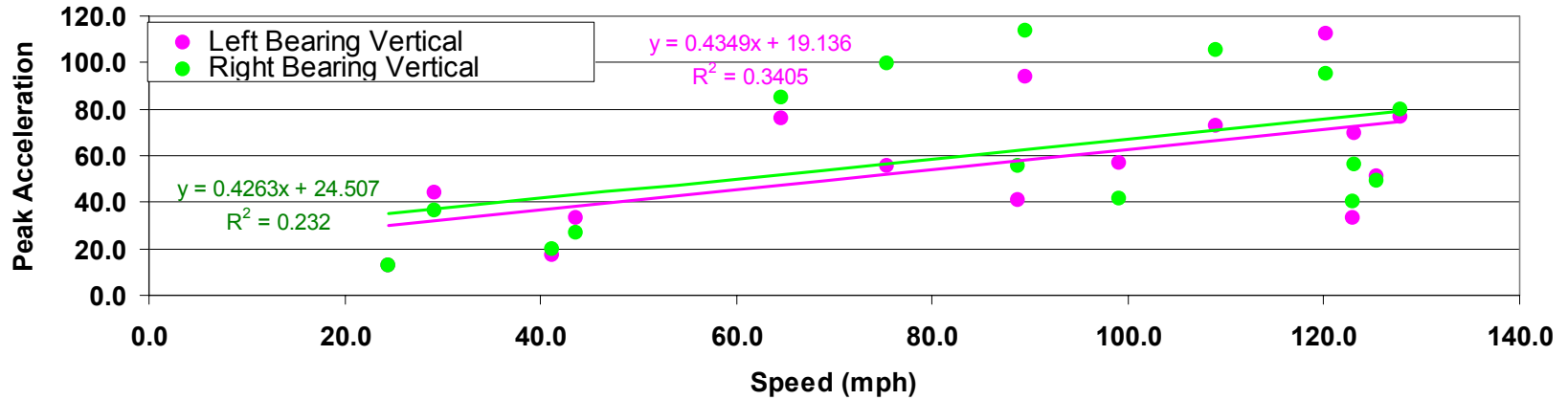

Day 4 Accelerations (99.9% Percentile)

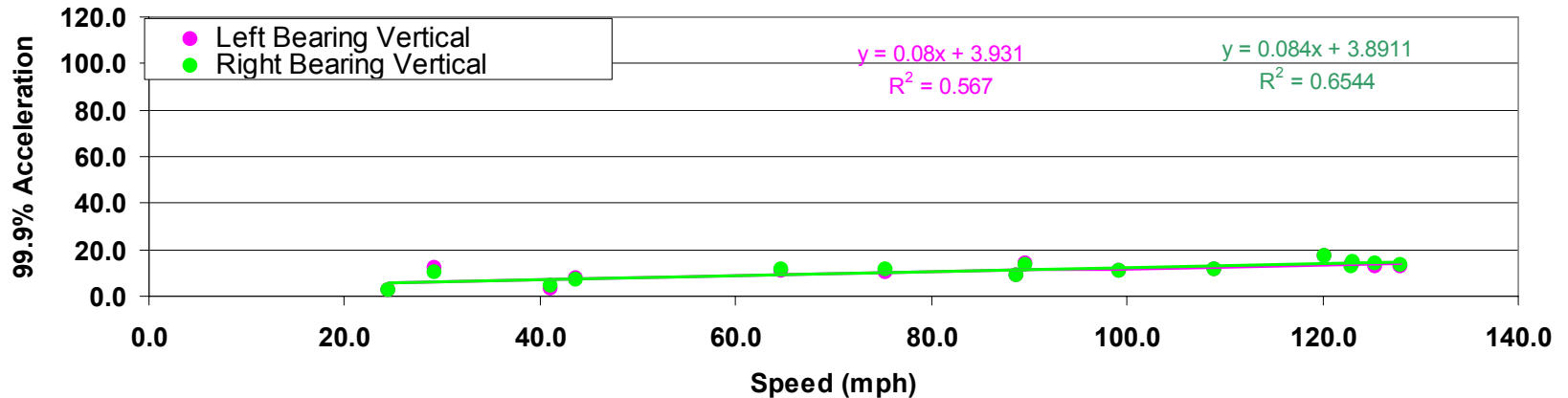

Conclusions–5/27/05

- The Car Tested With The Instrumented Axle In The Trailing Position
- Accelerations Generally Increase With Speed
- Lateral Acceleration Measured On The Bearing Generally Higher Than On The Axle
- Axle Bearing System Peak Accelerations
 - Vertical–113 G's
 - Lateral Bearing–45 G's
 - Lateral Axle–26 G's

Axle Lateral, Leading Versus Trailing

Leading vs Trailing Axle Configuration

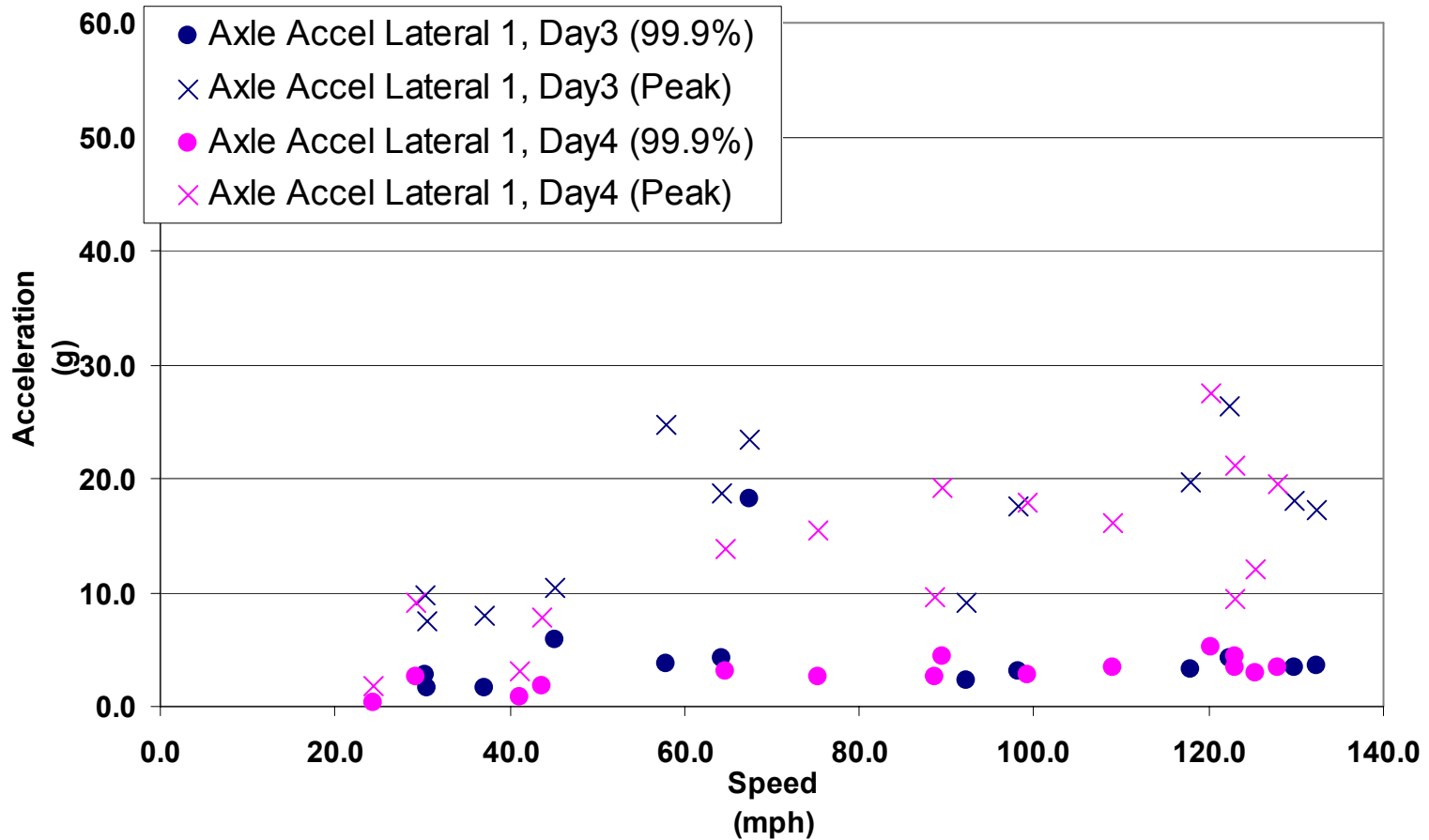

LBox Lateral, Leading Versus Trailing

Leading vs Trailing Axle Configuration

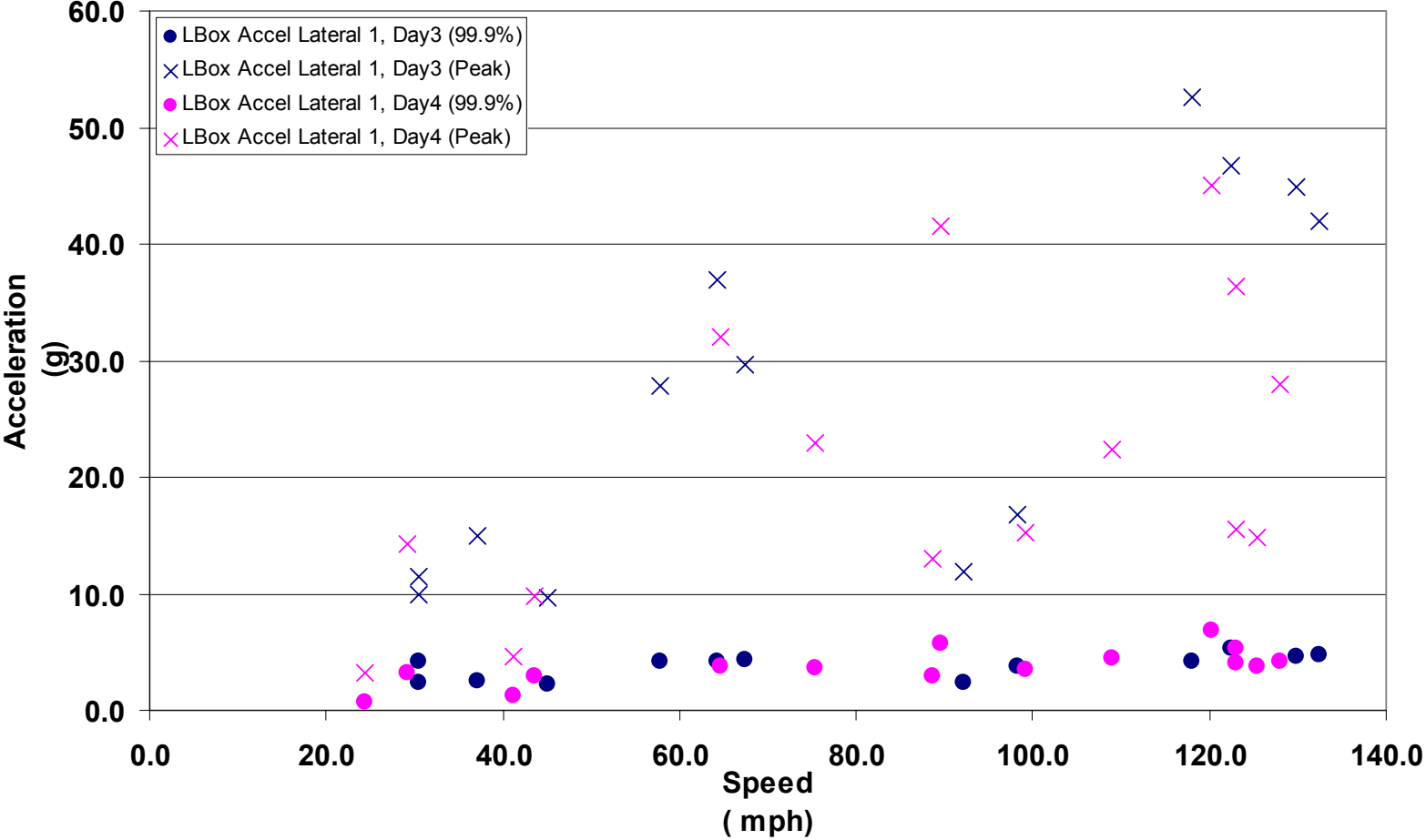

LBox Vertical, Leading Versus Trailing

Leading vs Trailing Axle Configuration

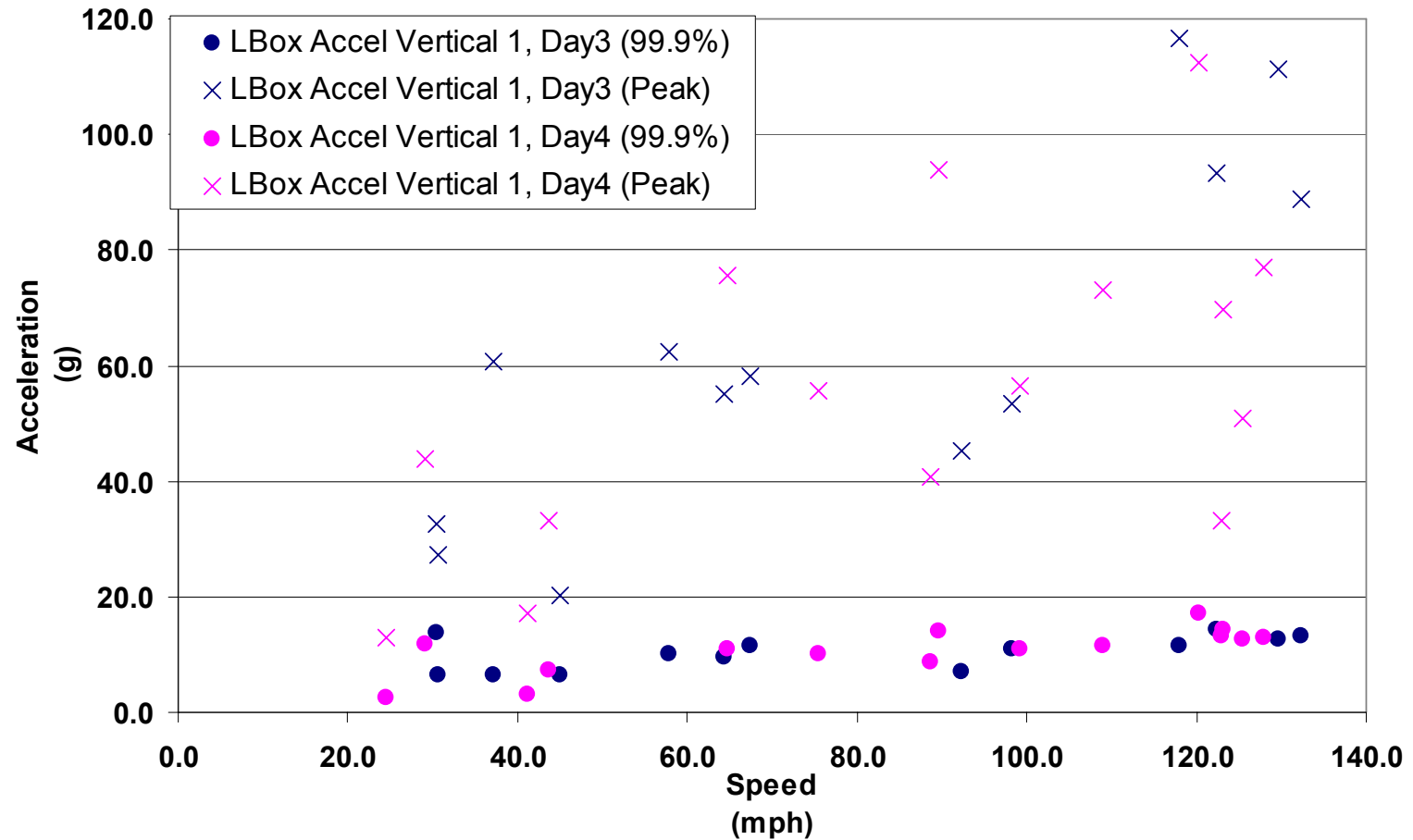

Vertical to Lateral Ratio

Ratio of Vertical to Lateral Acceleration (99.9% Percentile)

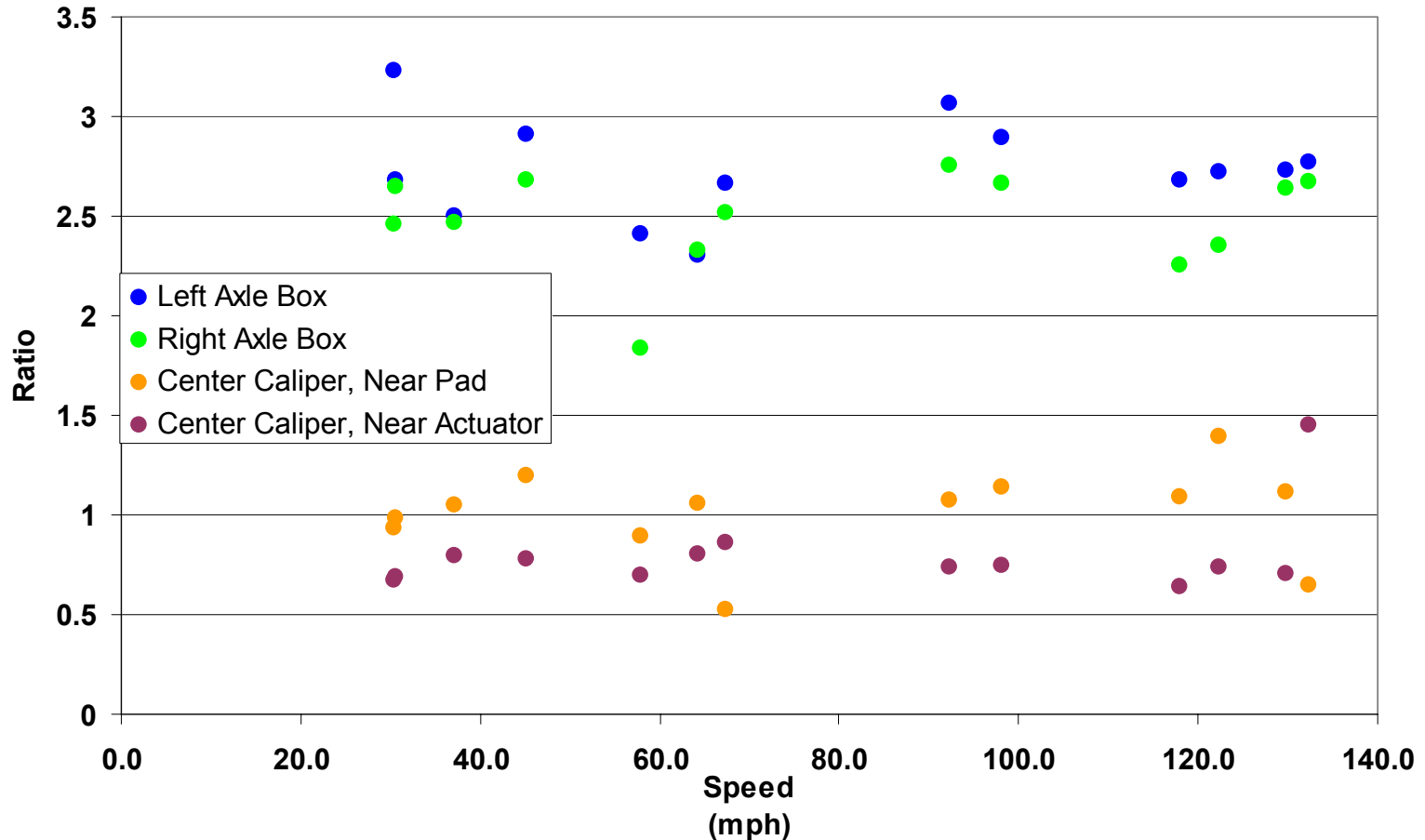

Vertical to Lateral Ratio

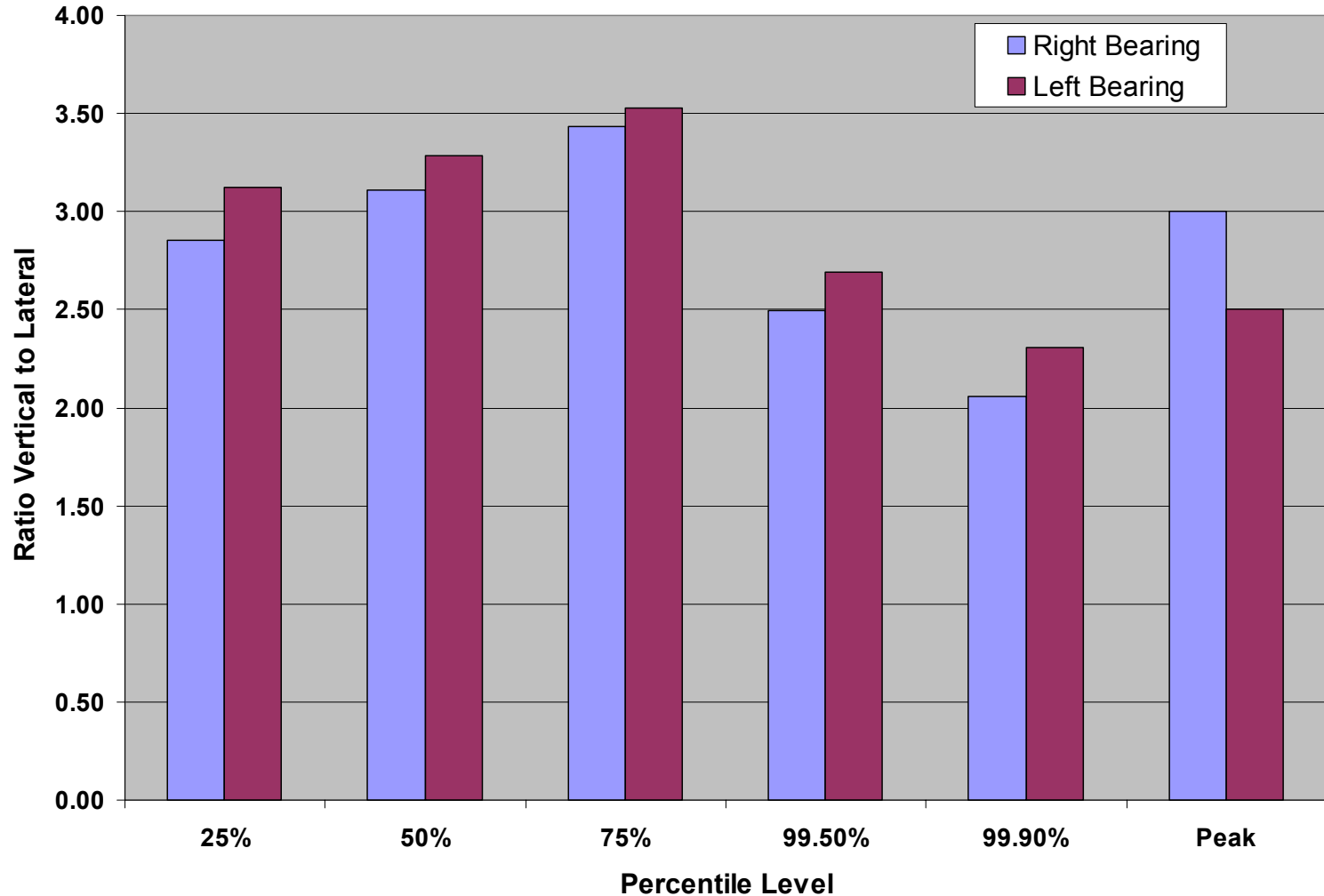

F-13

Other Observations

- Change in Accelerations due to Axle Position as Leading or Trailing is Negligible
- Vertical Accelerations on Bearing Boxes 2 to 3.5 times the Lateral Accelerations
- Vertical Accelerations on Calipers 0.5 to 1.5 times the Lateral Accelerations

Lateral Shocks

Table F.1 Lateral Accelerations Exceeding 30 G

Acceleration Range	May 16, 2005 Washington, DC, to Boston, MA Test Axle in Trail Position			May 17, 2005 Boston, MA, to Washington, DC Test Axle in Lead Position		
	W/S-W Left	W/S-W Right	W/S-W Axle	W/S-W Left	W/S-W Right	W/S-W Axle
30 g ≤ x < 40 g	0	2	0	0	4	0
40 g ≤ x < 50 g	0	0	0	0	0	0
50 g ≤ x < 60 g	0	0	0	0	0	0
60 g ≤ x < 70 g	0	0	0	0	0	0
70 g ≤ x < 80 g	0	0	0	0	0	0
80 g ≤ x	0	0	0	0	0	0

Total	0	2	0	0	4	0
Maximum	0	37.34	0	0	39.1	0
Minimum	0	37.05	0	0	32.07	0

Acceleration Range	May 26, 2005 Washington, DC, to Boston, MA Test Axle in Lead Position			May 27, 2005 Boston, MA, to Washington, DC Test Axle in Trail Position		
	W/S-W Left	W/S-W Right	W/S-W Axle	W/S-W Left	W/S-W Right	W/S-W Axle
30 g ≤ x < 40 g	22	8	0	12	6	0
40 g ≤ x < 50 g	6	3	0	6	4	0
50 g ≤ x < 60 g	2	2	0	0	2	0
60 g ≤ x < 70 g	0	0	0	1	2	0
70 g ≤ x < 80 g	1	0	0	0	0	0
80 g ≤ x	0	0	0	0	0	0

Total	31	13	0	19	14	0
Maximum	75.33	52.65	0	62.46	38.56	0
Minimum	30.04	-52.45	0	-44.97	-63.74	0

Represents the number of acceleration events where the lateral acceleration on the axle boxes exceeded 30 G.
The Right Box accelerometers were changed from the Silicon Design accelerometers to PCB accelerometers after Day 2.

Table F.1 Lateral Accelerations Exceeding 30 G

Acceleration Range	June 17, 2005 Washington, DC, to Boston, MA Test Axle in Lead Position					
	W/S-W Left	W/S-W Right	W/S-W Axle	Knorr Left	Knorr Right	Knorr Axle
30 g ≤ x < 40 g	15	8	0	15	10	0
40 g ≤ x < 50 g	2	1	0	3	0	0
50 g ≤ x < 60 g	1	1	0	1	0	0
60 g ≤ x < 70 g	0	0	0	0	0	0
70 g ≤ x < 80 g	0	0	0	0	0	0
80 g ≤ x	0	0	0	0	0	0

Total	18	10	0	19	10	0
Maximum	58.53	38.91	0	44.56	38.92	0
Minimum	-38.29	-51.37	0	-58.38	30.16	0

Acceleration Range	June 18, 2005 Boston, MA, to Washington, DC Test Axle in Lead Position					
	W/S-W Left	W/S-W Right	W/S-W Axle	Knorr Left	Knorr Right	Knorr Axle
30 g ≤ x < 40 g	8	8	0	6	7	0
40 g ≤ x < 50 g	6	1	0	0	1	0
50 g ≤ x < 60 g	2	0	0	0	0	0
60 g ≤ x < 70 g	0	0	0	0	0	0
70 g ≤ x < 80 g	0	0	0	0	0	0
80 g ≤ x	0	0	0	0	0	0

Total	16	9	0	6	8	0
Maximum	52.98	42.96	0	38.63	41.3	0
Minimum	30.52	30.78	0	-30.95	30.36	0

Represents the number of acceleration events where the lateral acceleration on the axle boxes exceeded 30 G.
The Right Box accelerometers were changed from the Silicon Design accelerometers to PCB accelerometers after Day 2.

Vertical Shocks

Table F.2 Vertical Accelerations Exceeding 50 G

Acceleration Range	May 16, 2005 Washington, DC, to Boston, MA Test Axle in Trail Position		May 17, 2005 Boston, MA, to Washington, DC Test Axle in Lead Position		May 26, 2005 Washington, DC, to Boston, MA Test Axle in Lead Position		May 27, 2005 Boston, MA, to Washington, DC Test Axle in Trail Position	
	W/S-W Left	W/S-W Right	W/S-W Left	W/S-W Right	W/S-W Left	W/S-W Right	W/S-W Left	W/S-W Right
	$50 \text{ g} \leq x < 60 \text{ g}$	45	42	34	38	58	74	45
$60 \text{ g} \leq x < 70 \text{ g}$	13	23	16	20	29	39	19	31
$70 \text{ g} \leq x < 80 \text{ g}$	18	6	8	7	11	16	17	24
$80 \text{ g} \leq x < 90 \text{ g}$	6	3	9	5	6	14	7	10
$90 \text{ g} \leq x < 100 \text{ g}$	5	6	4	12	5	8	8	7
$100 \text{ g} \leq x$	5	0	8	0	6	10	5	10

Total	92	80	79	82	115	161	101	137
Maximum	126.05	99.08	117.52	99.18	155.58	145	132.28	132.25
Minimum	-61.05	-52.97	-51.3	-69.67	-69.4	-52.02	-57.3	-69.54

Acceleration Range	June 17, 2005 Washington, DC, to Boston, MA Test Axle in Lead Position				June 18, 2005 Boston, MA, to Washington, DC Test Axle in Lead Position			
	W/S-W Left	W/S-W Right	Knorr Left	Knorr Right	W/S-W Left	W/S-W Right	Knorr Left	Knorr Right
	$50 \text{ g} \leq x < 60 \text{ g}$	35	50	36	37	36	30	37
$60 \text{ g} \leq x < 70 \text{ g}$	25	26	24	18	18	21	20	23
$70 \text{ g} \leq x < 80 \text{ g}$	17	13	10	23	6	8	12	13
$80 \text{ g} \leq x < 90 \text{ g}$	7	9	5	7	8	10	6	6
$90 \text{ g} \leq x < 100 \text{ g}$	3	5	10	2	2	6	1	2
$100 \text{ g} \leq x$	9	7	13	8	8	6	11	6

Total	96	110	98	95	78	81	87	82
Maximum	188.85	150.23	171.58	152.25	154.69	132.34	178.27	123.41
Minimum	50.02	50.35	50.03	50.03	50.31	50.07	50.61	50.13

Represents the number of acceleration events where the vertical acceleration on the axle boxes exceeded 50 G.
The Right Box accelerometers were changed from the Silicon Design accelerometers to PCB accelerometers after Day 2.

Vertical Accelerations Exceeding 100 G Versus Speed

100+ G Vertical Acceleration Events

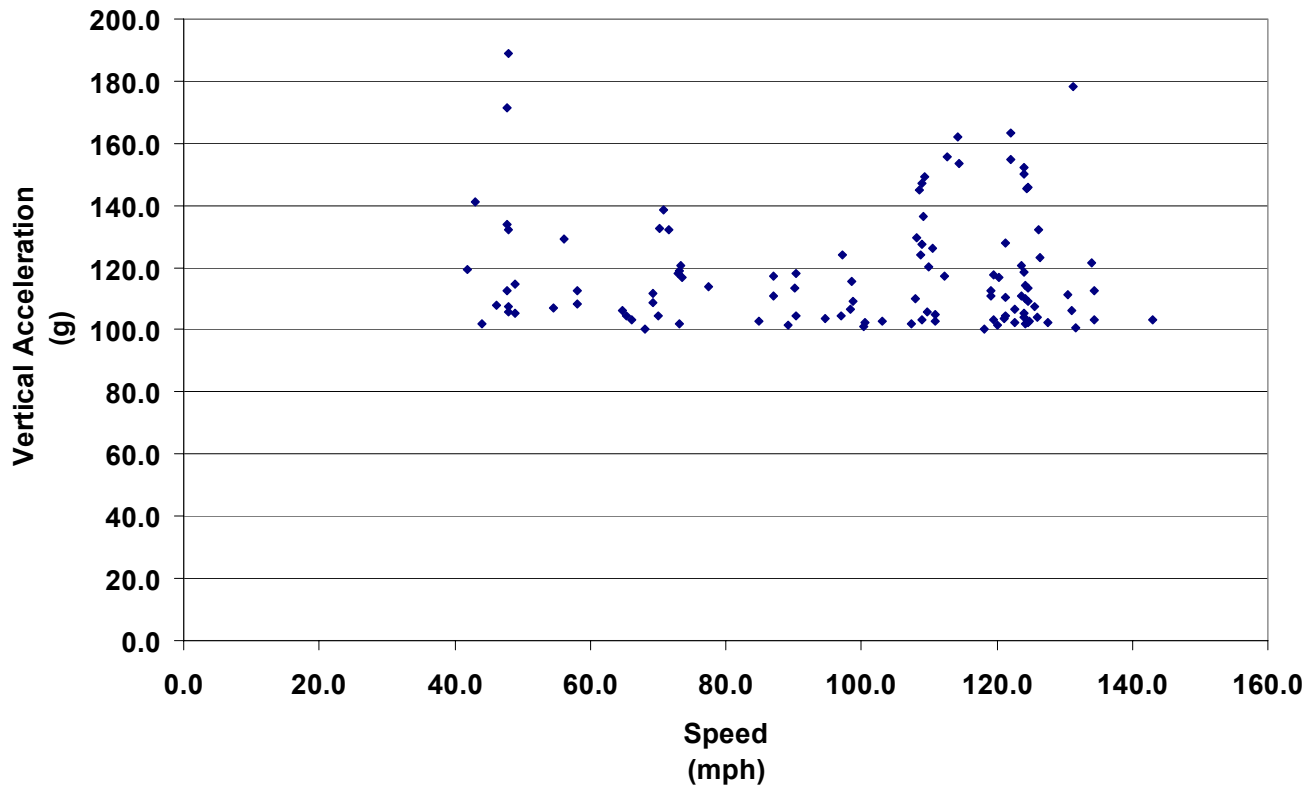

BOP Versus Vertical Acceleration

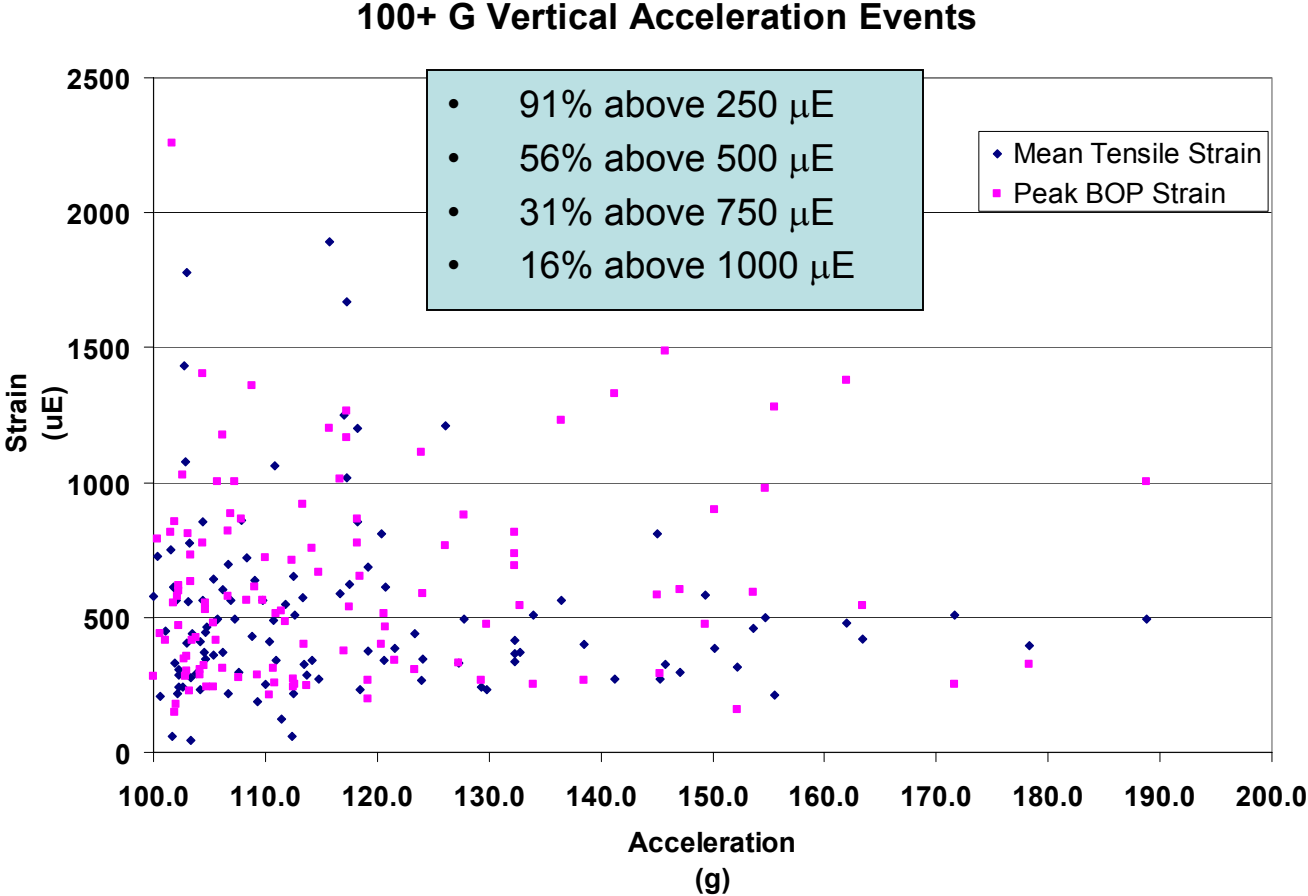

Vertical Impulse During Sustained Oscillations

AB3.1.30_CTRSPK6R1

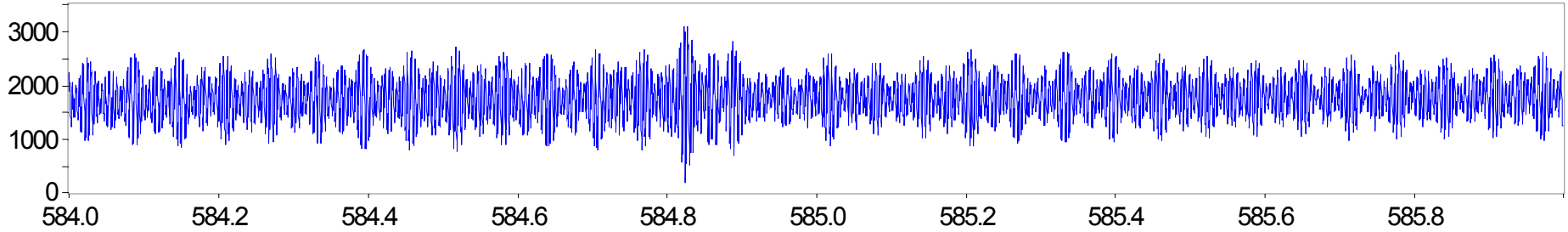

AB3.1.55_LBOXVERT1

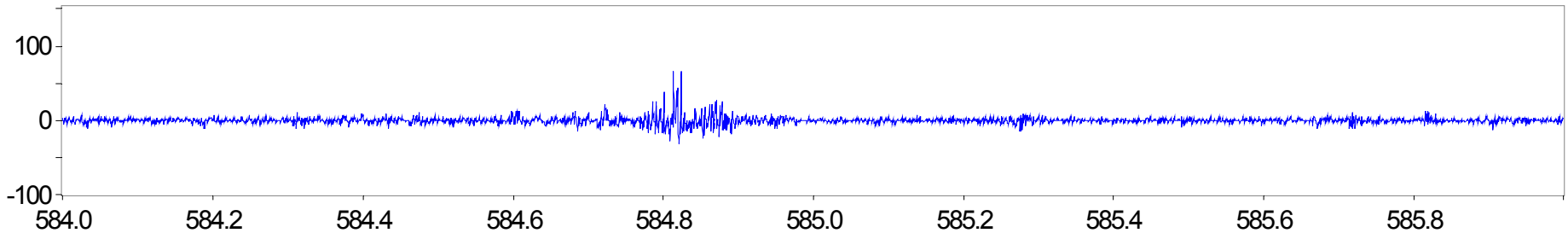

AB3.1.13_CYLPRESS1

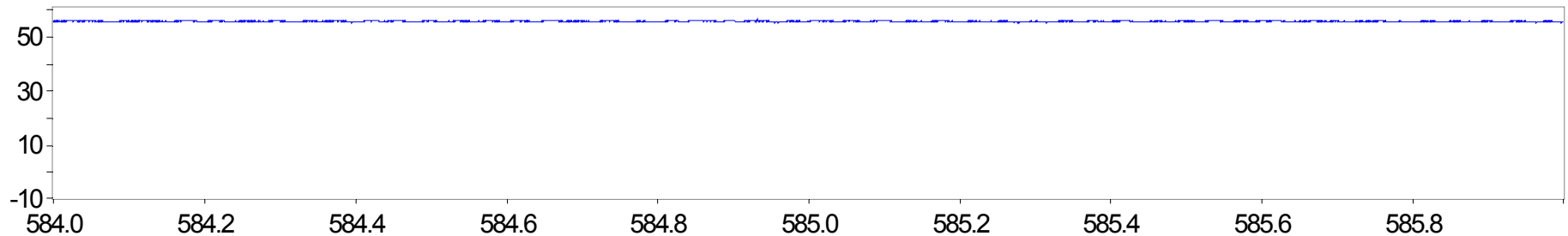

WABTEC/SAB-WABCO Disc

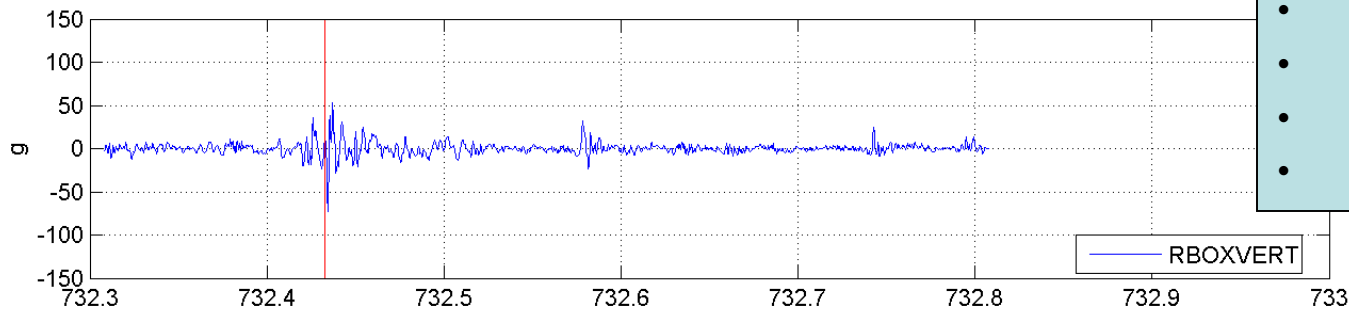
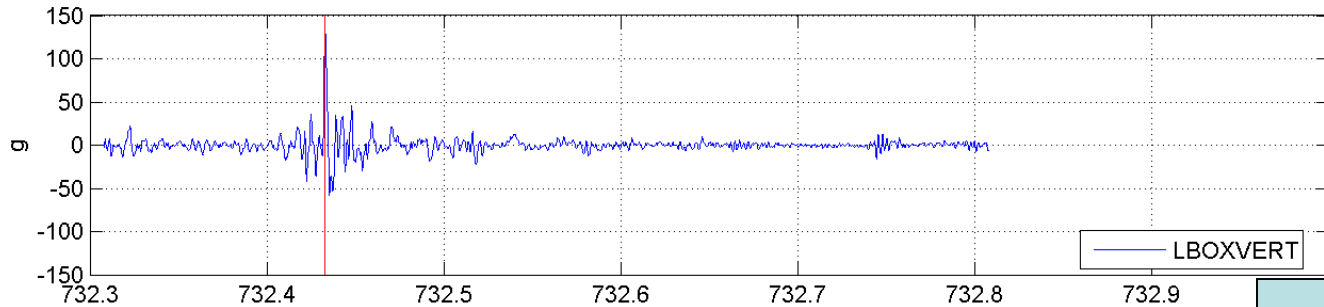

- Speed = 124.5 mph
- LBOXVERT = 145.75 g
- RBOXVERT = -73.05 g
- BOP = 1487 μ E
- Brake Pressure = 0.439 psi

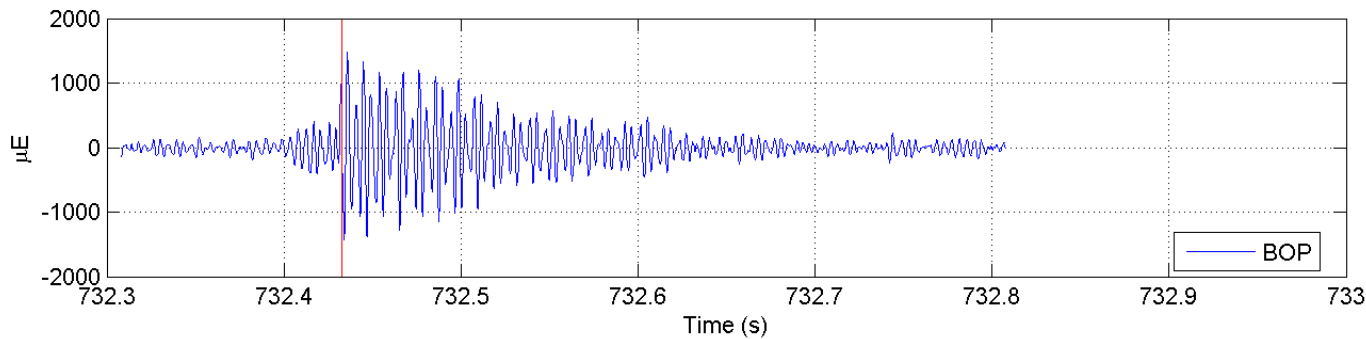

Day 7 (6/18/2005)–File 30

Knorr Disc

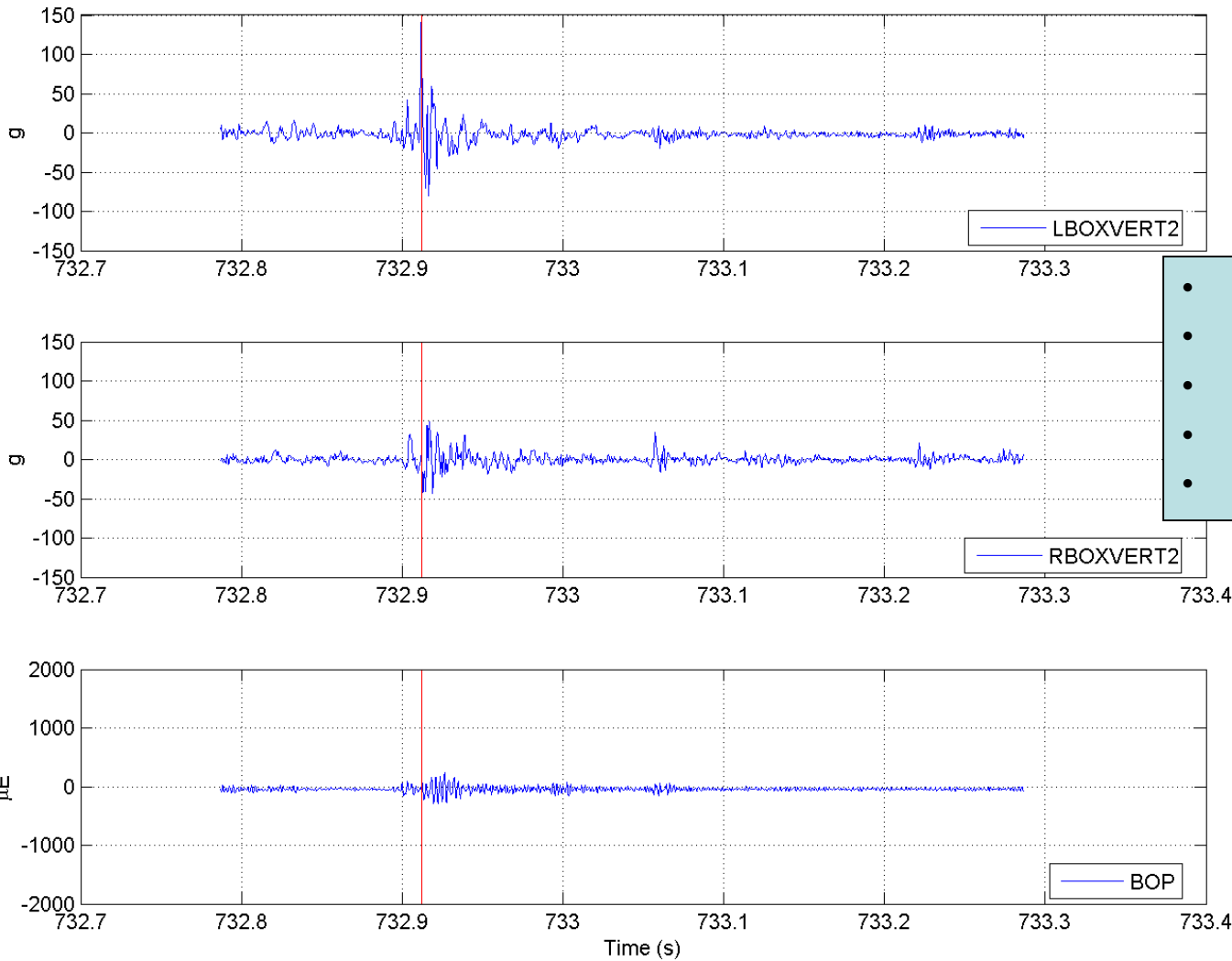

- Speed = 124.5 mph
- LBOXVERT = 145.29 g
- RBOXVERT = -48.61 g
- BOP = 290 μE
- Brake Pressure = 0.25 psi

Day 7 (6/18/2005)–File 30

Day 6–File 25

WABTEC/SAB-WABCO Disc, BOP = (R1 - R2)/2, Center Rotor, Spoke 6

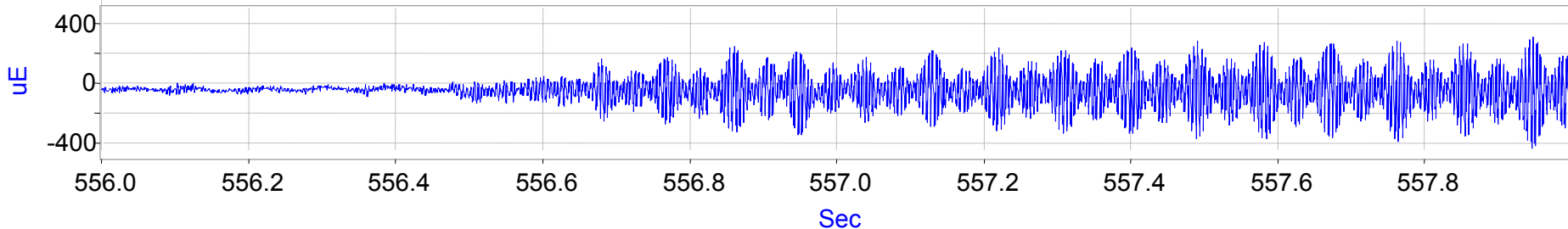

WABTEC/SAB-WABCO Disc, Left Box Vertical Acceleration

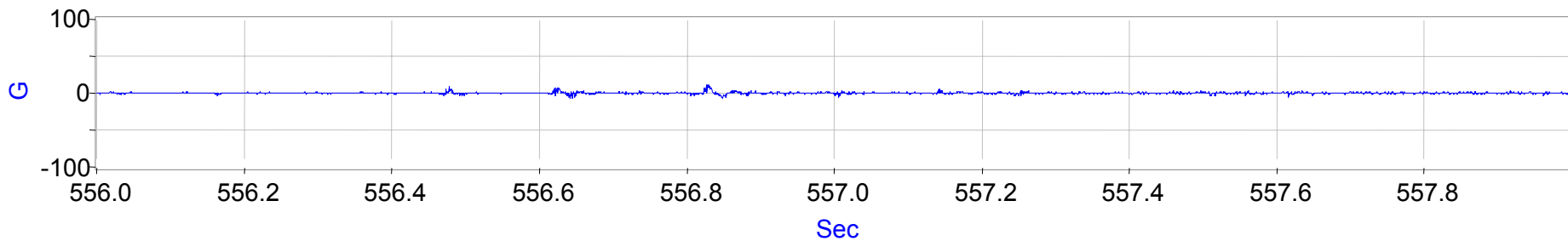

WABTEC/SAB-WABCO Disc, Right Box Vertical Acceleration

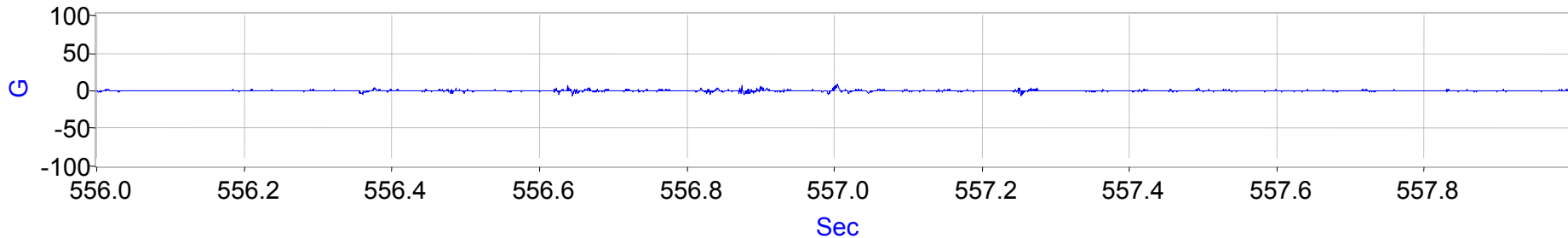

Day 6-File 25

WABTEC/SAB-WABCO Disc, BOP = (R1 - R2)/2, Center Rotor, Spoke 6

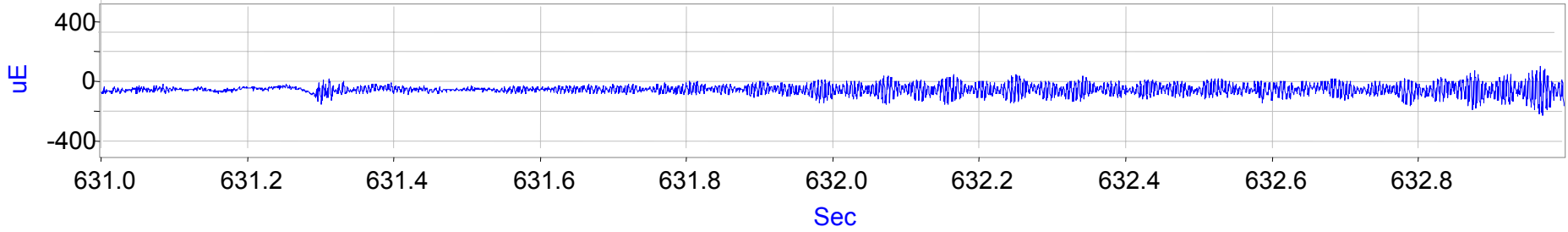

WABTEC/SAB-WABCO Disc, Left Box Vertical Acceleration

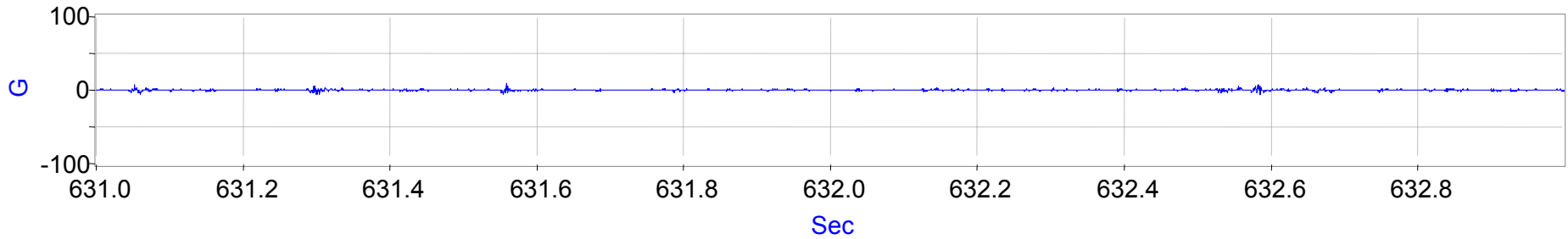

WABTEC/SAB-WABCO Disc, Right Box Vertical Acceleration

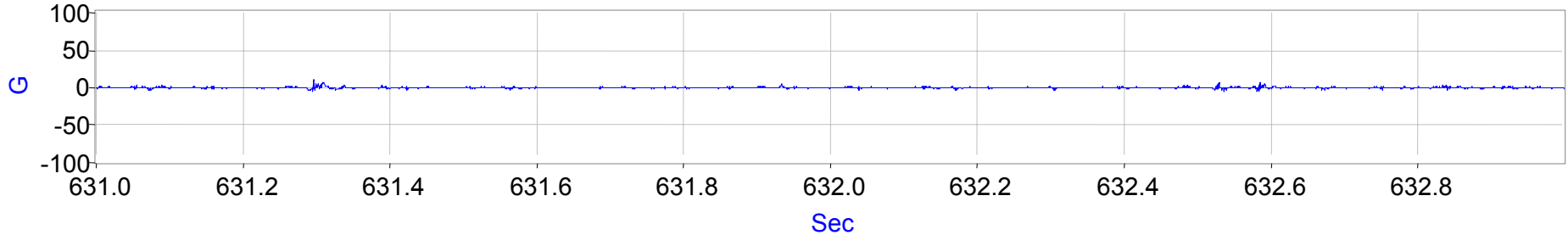

Table F.3 Details of Vertical Accelerations Exceeding 100 G

Num	Day	Location			Physical Track Feature	Axle	Side of Car	Speed (MPH)	Brake Cylinder Pressure (PSI)	Mean Tensile Stress - Center Disc (μE)	Peak BOP - Center Disc (μE)	Acceleration (G)
		Feet	Dir.	MP								
1	5/17	12916	E of	AB225	?	1	Left	119.5	0.6	46	734	103.4
2	5/27	963	NE of	AB224	Plains Interlocking	1	Left	120.1	1.2	61	2258	101.6
3	5/26	2210	NE of	AB223	Forest Interlocking	1	Left	120.3	0.8	589	1015	116.6
4	5/27	1147	SW of	AB224		1	Left	119.2	1.2	58	712	112.4
5	6/18	1952	SW of	AB220	Read Interlocking	2	Right	126.3	0.4	441	305	123.4
6	6/18	2137	SW of	AB220		1	Right	126.2	0.4	413	737	132.3
7	6/18	69	N of	AB219	Switch	2	Right	125.9	0.3	411	286	104.2
8	5/26	721	SW of	AB219		1	Right	108.5	0.8	811	585	145.0
9	6/18	2101	NE of	AB218	Transfer Interlocking	2	Left	131.2	0.3	396	326	178.3
10	6/18	2293	NE of	AB218		1	Left	131.1	0.4	372	1175	106.2
11	5/26	540	SW of	AB170	?	1	Right	143.0	24.1	777	229	103.3
12	6/18	1591	NE of	MN71	Undergrade Bridge	2	Left	43.9	0.3	562	180	102.0
13	6/18	1415	NE of	MN66	CP 266	2	Left	77.4	0.3	289	249	113.7
14	5/17	820	W of	MN61	CP 261	1	Left	54.6	0.9	562	883	106.9
15	6/17	1147	SW of	MN56	Undergrade Bridge	2	Right	47.8	0.4	508	254	112.6
16	6/17	1211	SW of	MN56		2	Left	47.8	0.4	508	254	134.0
17	6/17	1211	SW of	MN56		2	Left	47.8	0.4	508	254	171.6
18	6/17	1276	SW of	MN56		1	Left	47.9	0.4	496	1003	188.9
19	6/17	1276	SW of	MN56		1	Right	47.9	0.4	496	1003	105.7
20	6/17	1276	SW of	MN56		1	Right	47.9	0.4	496	1003	107.3
21	5/26	1315	SW of	MN56		1	Right	43.0	0.6	271	1327	141.2
22	6/18	1448	SW of	MN56		2	Right	41.9	0.4	377	268	119.2

Table F.3 Details of Vertical Accelerations Exceeding 100 G

Num	Day	Location			Physical Track Feature	Axle	Side of Car	Speed (MPH)	Brake Cylinder Pressure (PSI)	Mean Tensile Stress - Center Disc (μE)	Peak BOP - Center Disc (μE)	Acceleration (G)
		Feet	Dir.	MP								
23	5/27	1139	NE of	MN41	CP 241	1	Right	48.0	1.4	334	814	132.3
24	6/18	1510	E of	MN33	CP 234	1	Right	48.9	0.3	270	669	114.8
25	6/17	1872	NE of	MN32	Grade Crossing	2	Left	68.1	14.7	577	284	100.0
26	6/18	2039	NE of	MN32		2	Left	56.2	0.4	244	265	129.3
27	6/17	2164	NE of	MN32		2	Right	64.7	15.1	603	313	106.2
28	5/26	249	NE of	MN29	CP 229	1	Right	69.3	0.8	549	486	111.8
29	5/26	570	SW of	MN29		1	Left	70.1	0.8	565	1405	104.4
30	5/27	348	NE of	MN29		1	Left	71.5	1.3	366	690	132.3
31	6/17	324	SW of	MN29		2	Right	73.2	0.5	687	196	119.2
32	6/17	431	SW of	MN29		1	Left	73.2	0.5	611	554	101.8
33	6/17	431	SW of	MN29		1	Right	73.3	0.5	611	463	120.7
34	6/18	166	NE of	MN29		1	Right	65.3	0.4	373	320	104.5
35	6/18	166	NE of	MN29		2	Right	66.1	0.4	404	354	103.0
36	6/18	428	SW of	MN29		1	Left	70.2	0.4	369	546	132.7
37	6/18	530	SW of	MN29		2	Left	70.7	0.4	402	269	138.4
38	5/27	2154	NE of	MN23	CP 223	1	Right	69.3	1.4	429	1359	108.8
39	6/17	2529	SW of	AN10	Hunter Interlocking	2	Right	73.5	0.5	1250	378	117.0
40	6/17	2634	SW of	AN10		1	Right	73.0	0.5	1203	866	118.2
41	5/17	420	SW of	AN12	Lane Interlocking	1	Left	108.0	0.9	250	720	110.0
42	5/26	1222	SW of	AN12		1	Right	107.3	0.8	610	854	101.9
43	6/18	450	SW of	AN12		1	Left	108.9	0.4	294	601	147.1
44	6/18	450	SW of	AN12		2	Left	108.9	0.4	329	333	127.3

Table F.3 Details of Vertical Accelerations Exceeding 100 G

Num	Day	Location			Physical Track Feature	Axle	Side of Car	Speed (MPH)	Brake Cylinder Pressure (PSI)	Mean Tensile Stress - Center Disc (μE)	Peak BOP - Center Disc (μE)	Acceleration (G)
		Feet	Dir.	MP								
45	5/26	2174	NE of	AN20	Union Interlocking	1	Left	112.6	0.8	213	1279	155.6
46	5/27	1979	SW of	AN19		1	Right	90.1	1.5	325	400	113.5
47	6/17	1371	NE of	AN20		2	Left	111.0	0.5	467	244	104.8
48	6/17	2194	NE of	AN20		2	Left	114.4	0.4	459	595	153.7
49	6/17	2362	NE of	AN20		1	Left	114.1	0.5	477	1379	161.9
50	6/18	1083	NE of	AN20		2	Left	103.0	0.4	1078	283	102.9
51	5/16	1734	E of	AN26	Lincoln Interlocking	1	Left	100.4	1.6	451	416	101.0
52	5/26	1367	E of	AN26		1	Left	97.1	0.8	345	589	124.1
53	5/26	1367	E of	AN26		1	Right	97.1	0.8	344	531	104.6
54	6/17	1316	E of	AN26		1	Left	109.2	0.5	563	1230	136.5
55	6/17	1476	E of	AN26		2	Left	109.2	0.5	584	475	149.3
56	6/17	1796	E of	AN26		1	Right	108.9	0.5	557	812	103.2
57	5/16	872	SW of	AN30	Signal Bridge	1	Left	124.3	1.6	330	149	101.9
58	5/26	45	W of	AN32.5	County Interlocking	1	Left	124.6	0.8	244	599	102.2
59	5/27	300	SW of	AN32.5		1	Right	124.2	1.6	339	756	114.2
60	6/17	35	W of	AN32.5		1	Left	121.2	0.5	446	555	104.6
61	6/17	166	NE of	AN32.5		2	Left	121.1	0.5	441	414	103.5
62	5/17	392	NE of	AN32.5	?	1	Left	119.6	0.9	623	538	117.5
63	5/27	431	NE of	AN32.5		1	Right	123.6	1.6	343	516	111.0
64	5/27	431	NE of	AN32.5		1	Right	123.6	1.6	343	516	120.7
65	6/17	696	NE of	AN32.5		2	Right	119.2	28.3	487	313	110.8
66	5/26	2350	NE of	AN42	Midway Interlocking	1	Left	130.5	0.8	125	524	111.4
67	5/27	1641	SW of	AN41		1	Right	131.7	1.6	208	441	100.6
68	6/17	1939	SW of	AN41		1	Left	134.3	0.5	277	631	103.3
69	6/17	1939	SW of	AN41		2	Left	134.4	0.5	218	272	112.5

Table F.3 Details of Vertical Accelerations Exceeding 100 G

Num	Day	Location			Physical Track Feature	Axle	Side of Car	Speed (MPH)	Brake Cylinder Pressure (PSI)	Mean Tensile Stress - Center Disc (μE)	Peak BOP - Center Disc (μE)	Acceleration (G)
		Feet	Dir.	MP								
70	5/16	984	NE	of AN55.5	Ham Interlocking	1	Left	110.6	0.5	1208	766	126.1
71	5/26	937	NE	of AN55.5		1	Right	108.2	0.8	230	475	129.7
72	5/27	173	N	of AN55.5		1	Left	108.8	1.7	268	1113	124.0
73	6/18	154	W	of AN55.5		1	Right	98.7	55.7	1894	1202	115.8
74	6/18	694	NE	of AN55.5		1	Left	112.3	56.0	1668	1168	117.3
75	6/18	694	NE	of AN55.5		2	Left	111.0	56.0	1779	303	103.0
76	5/16	1726	SW	of AN77	Holmes Interlocking	1	Left	100.6	0.5	304	468	102.2
77	5/17	2512	SW	of AN77		1	Left	98.8	0.9	635	614	109.1
78	5/27	2336	SW	of AN77		1	Right	98.3	1.8	698	823	106.7
79	6/17	1327	SW	of AN77		2	Right	124.1	0.6	317	158	152.3
80	6/17	1509	SW	of AN77		1	Right	124.0	0.6	385	902	150.2
81	6/18	2613	SW	of AN77		1	Left	122.1	0.4	501	978	154.7
82	6/18	2613	SW	of AN77		2	Left	122.0	0.4	422	544	163.4
83	6/18	2143	NE	of AN78		2	Right	121.2	0.4	412	212	110.3
84	6/18	2320	NE	of AN78	1	Right	121.3	0.4	494	879	127.8	
85	6/17	486	SW	of AN85.5	N. Phil Interlocking	2	Left	58.1	0.5	653	244	112.5
86	6/17	570	SW	of AN85.5		1	Left	58.0	0.5	719	563	108.4
87	5/16	1676	NE	of AP4	Phil Interlocking	1	Left	94.7	11.8	291	427	103.8
88	6/17	2347	NE	of AP4		2	Left	84.9	44.7	1435	344	102.7
89	6/17	147	NE	of AP16.8	Hook Interlocking	2	Left	109.9	0.4	810	399	120.3
90	5/27	2159	SW	of AP20	Holly Interlocking	1	Right	109.7	2.7	491	413	105.6
91	6/18	1801	SW	of AP20		2	Right	125.7	0.4	295	275	107.6
92	6/17	1352	E	of AP30	Ragan Interlocking	2	Left	124.1	0.5	361	242	105.3
93	6/18	1326	E	of AP30		1	Right	118.1	0.4	728	792	100.4
94	5/26	2362	E	of AP39	Davis Interlocking	1	Right	127.6	1.0	285	620	102.3
95	6/17	2577	W	of AP38		2	Right	133.9	0.5	385	341	121.6

Table F.3 Details of Vertical Accelerations Exceeding 100 G

Num	Day	Location			Physical Track Feature	Axle	Side of Car	Speed (MPH)	Brake Cylinder Pressure (PSI)	Mean Tensile Stress - Center Disc (μE)	Peak BOP - Center Disc (μE)	Acceleration (G)
		Feet	Dir.	MP								
96	5/17	1009	W of	AP60	Grace Interlocking	1	Left	89.1	0.7	751	818	101.5
97	5/27	906	W of	AP60		1	Left	90.4	2.9	855	776	104.5
98	5/27	906	W of	AP60		1	Right	90.4	2.9	855	776	118.2
99	6/18	1180	W of	AP60		2	Left	87.0	0.4	1064	258	110.9
100	6/18	1308	W of	AP60		1	Left	87.0	0.4	1018	1263	117.2
101	5/17	625	NE of	AP63	Oak Interlocking	1	Left	124.2	0.7	564	564	109.8
102	6/17	1038	NE of	AP63		2	Right	124.7	0.5	187	287	109.4
103	5/26	2192	SW of	AP75	Wood Interlocking	1	Right	122.7	2.2	217	580	102.2
104	5/26	2192	SW of	AP75		1	Right	122.7	2.2	217	580	106.7
105	6/17	2256	SW of	AP75		1	Right	124.7	0.4	575	920	113.3
106	6/18	1265	SW of	AP75		1	Left	124.5	0.4	328	1487	145.8
107	6/18	1448	SW of	AP75		2	Left	124.4	0.4	273	290	145.3
108	5/17	621	NW of	AP94	Biddle Interlocking	1	Left	48.9	0.7	644	479	105.3
109	6/18	709	NW of	AP94		1	Left	46.1	4.7	861	863	107.8
110	6/17	2294	S of	AP102	?	1	Left	124.0	0.5	230	651	118.5
111	6/17	2477	S of	AP102		2	Left	123.9	0.5	231	307	104.2
112	6/17	2476	S of	AP112	Grove Interlocking	1	Left	124.7	0.5	240	1028	102.7

Vertical Acceleration Events

- For any given sensor location, vertical acceleration exceeds 100 G on the axle boxes approximately 5–13 times per day
- The events where acceleration exceeds 100 G can be grouped into approximately 48 instances for the entire Northeast Corridor for all 6 runs between Boston and DC
- The correlation between accelerations above 100 G and speed is small
- Accelerations above 100 G were observed at speeds greater than 40 mph
- The number of high acceleration events remains similar each day and on each axle
- The Silicon Design accelerometers used on the right box on Days 1 and 2 produced questionable results
- Vertical acceleration events sometimes cause a brake disc oscillation of short duration regardless of whether brakes are applied
- Vertical acceleration events are usually not associated with sustained brake disc oscillations that occur during braking
- Vertical acceleration events during sustained oscillation can increase the severity of the BOP for a short duration

Relationship of BOP Strain During Non-Braking Conditions to Acceleration Differences

The Problem

- During Non-Braking Conditions, The WABTEC/SAB-WABCO Disc Responds To Track Input From The Right Rail Or The Left Rail
- The Response Mode Is An Asymmetric Out-Of-Plane Bending Of The Spokes
- What Are The Characteristics Of This Response?

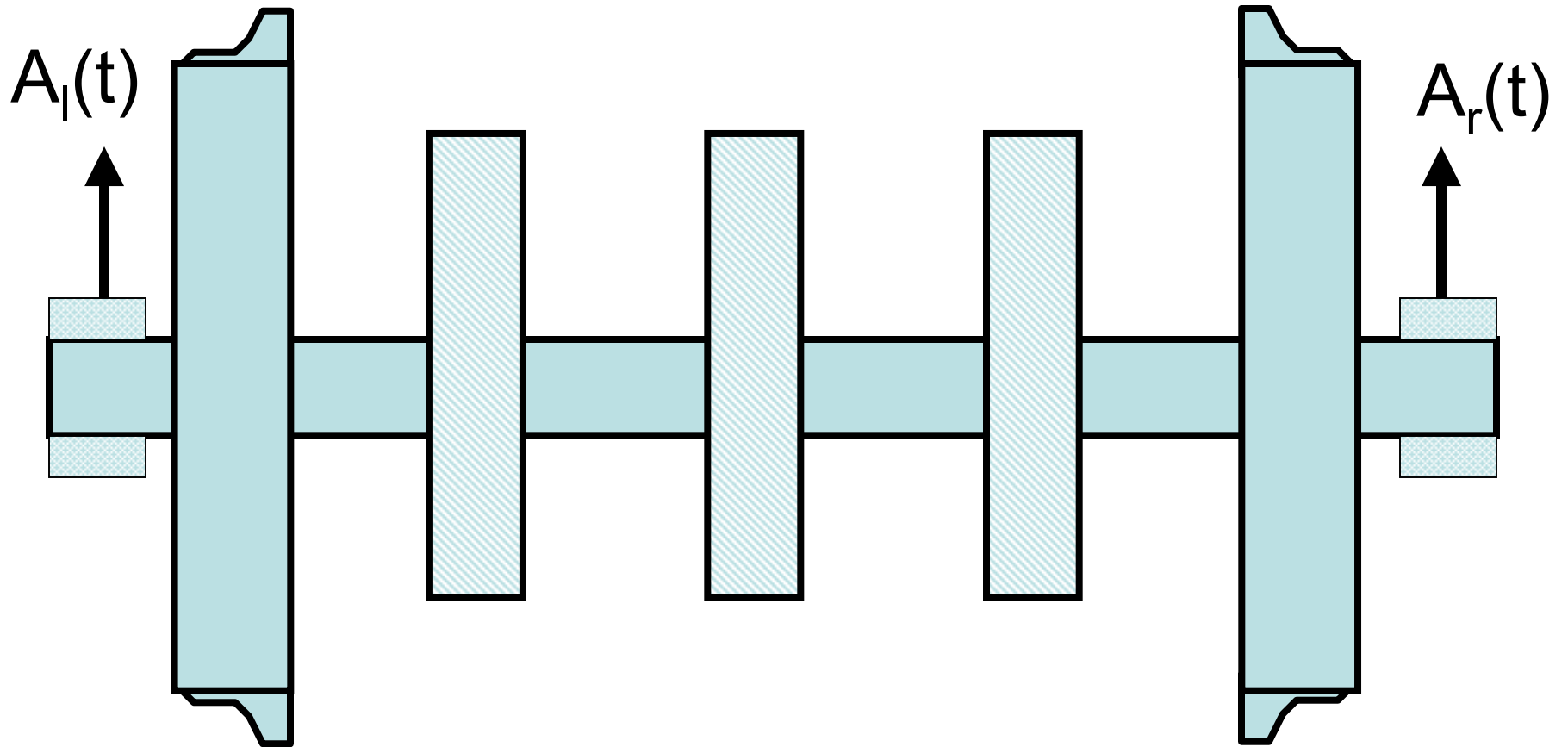

Acceleration Difference = $A_l(t) - A_r(t)$

Model Bump Acceleration

Motion

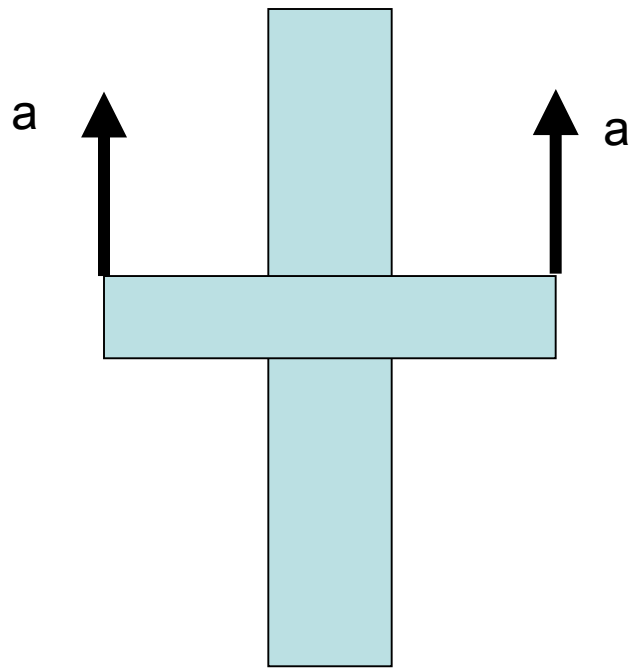

Equal Accelerations
In Same Direction

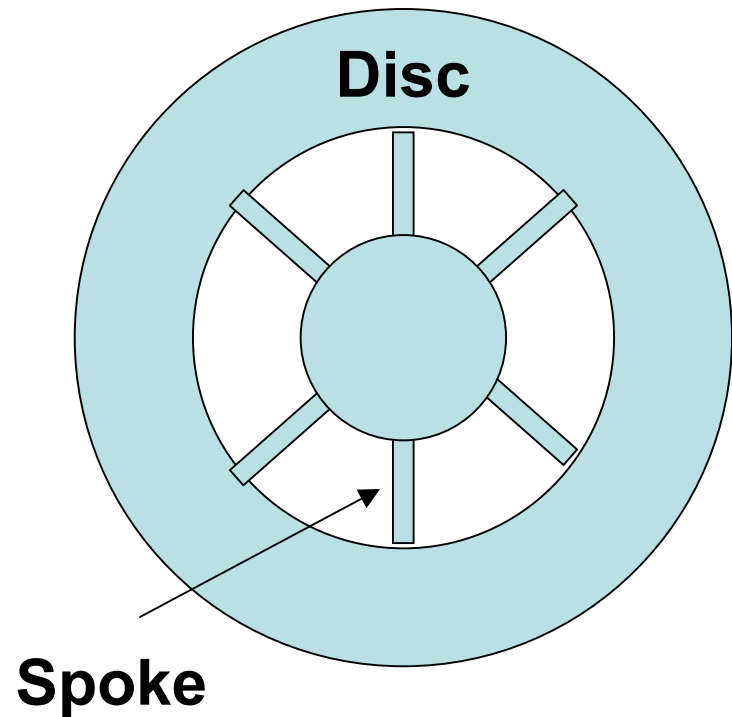

Model for Bump Acceleration

- This Mode Of Motion Does Not Excite An Out-Of-Plane Response Of The Spokes
- Since The Major Events Of High Axle Box Acceleration Are Predominantly A Single Side Event, The Value Of The Bump Acceleration Is Approximately Equal To The Acceleration Difference

Model for Acceleration Difference

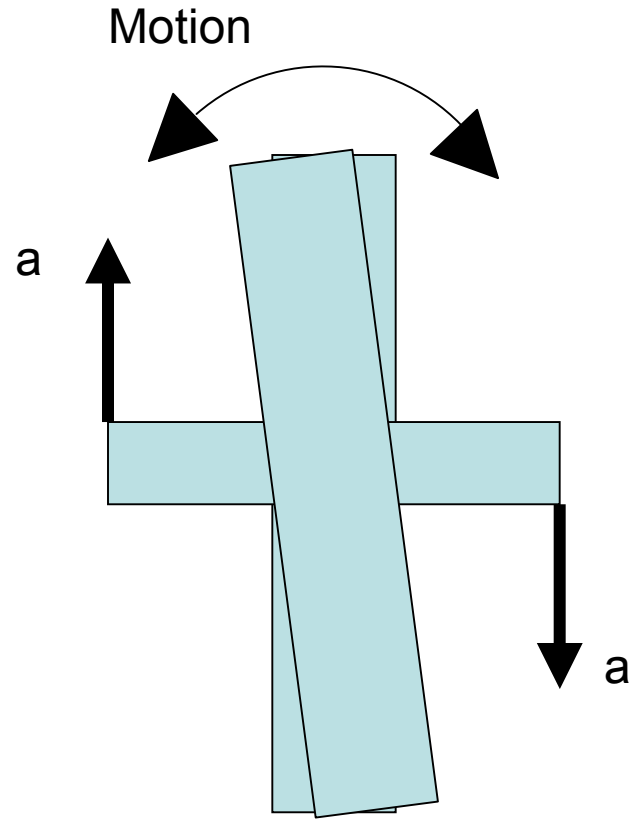

Equal and Opposite Accelerations

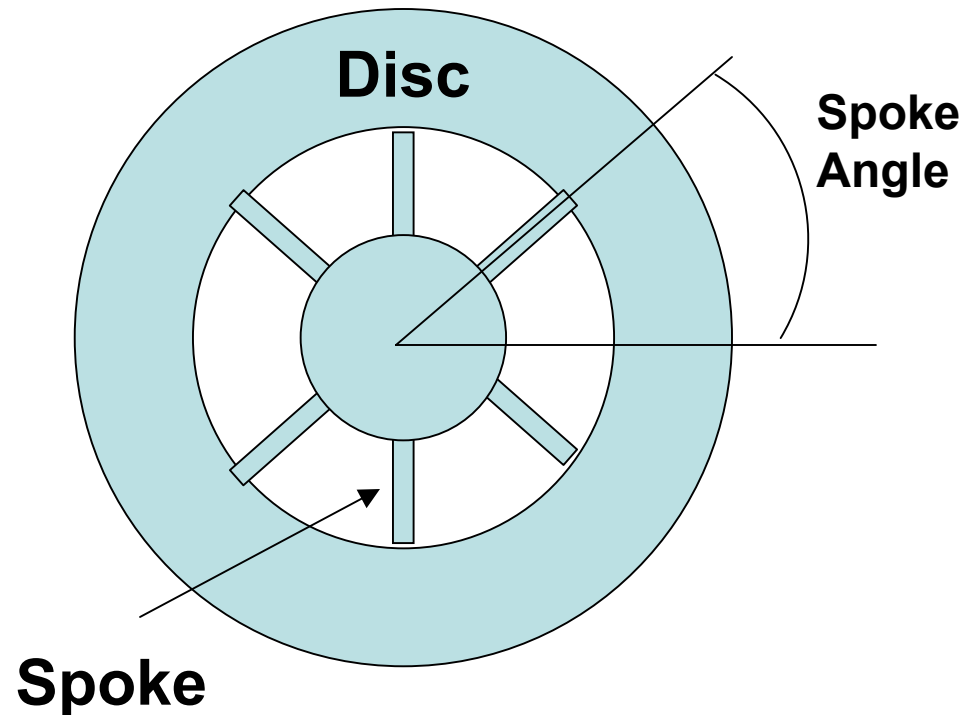

Approach

- Selected Events From May 26 Where Right Acceleration Levels Were Above 100 G's
- Observed BOP Strains Resulting From These Events
- Analyzed The Tilt Acceleration And Spoke 6 BOP Levels
- Plotted Tilt Acceleration Times The Sine Of Spoke 6 Position Angle Versus The Peak BOP Acceleration That Resulted From This Acceleration

Example 1

Tilt acceleration normalized to a peak value of 5 to allow the peak acceleration signal to be associated with a phase angle (for analysis purposes only)

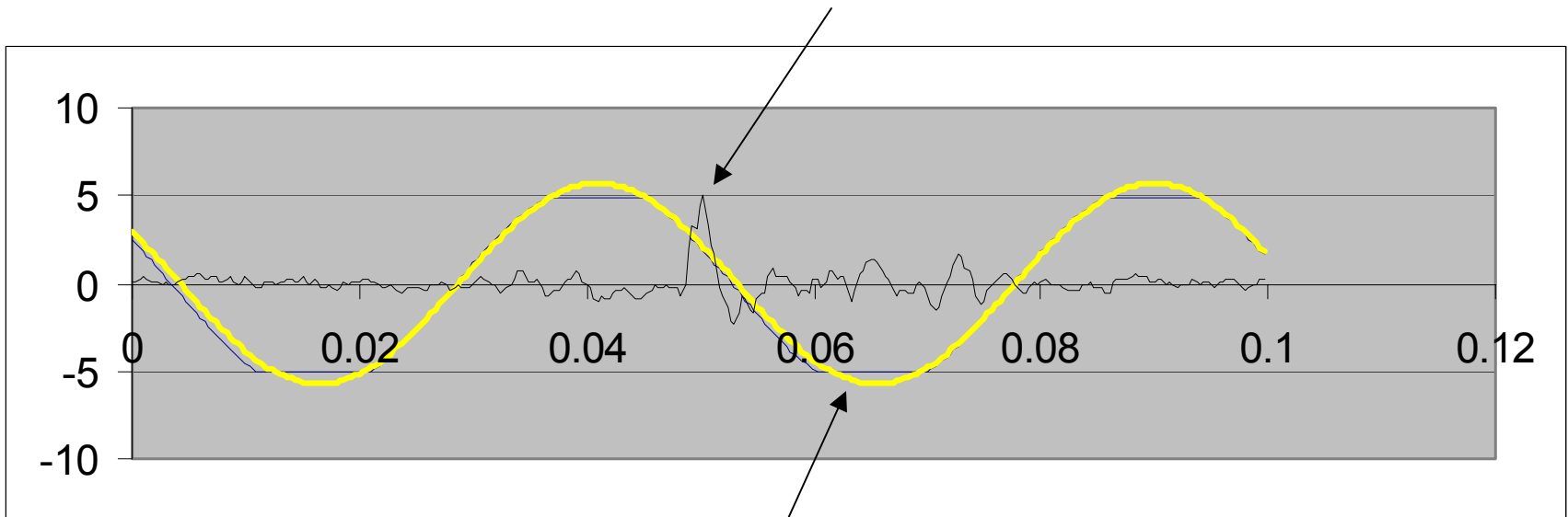

Slip Ring Output

Example 2

Tilt acceleration normalized to a peak value of 5 to allow the peak acceleration signal to be associated with a phase angle (for analysis purposes only)

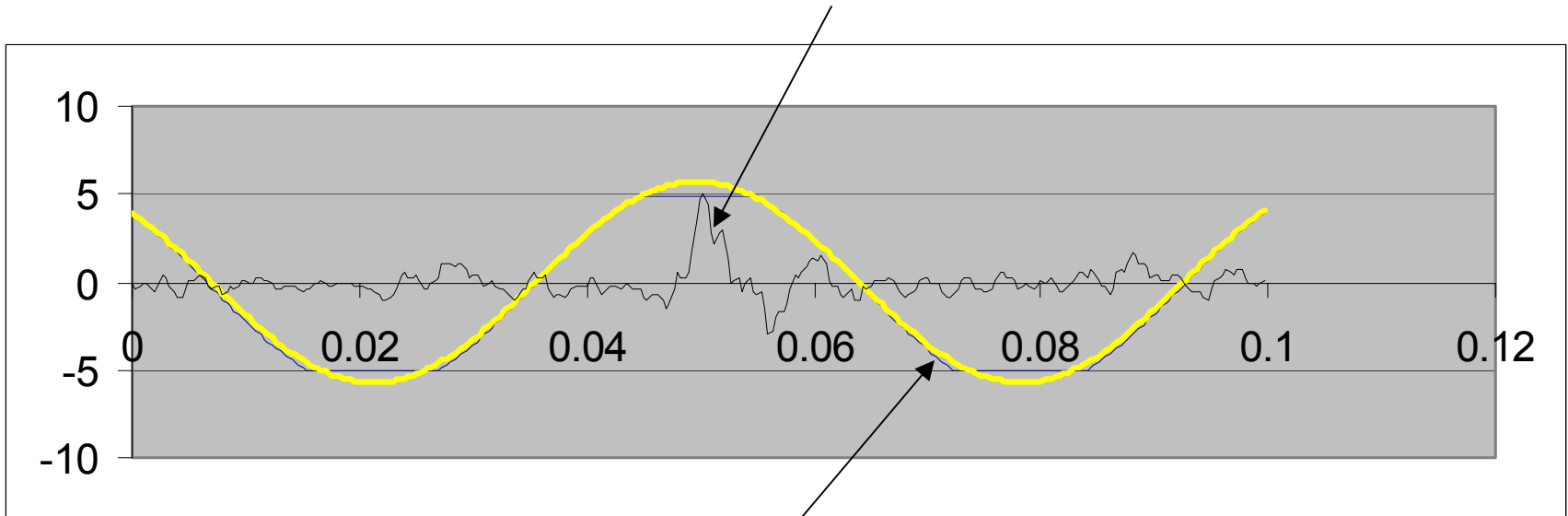

Slip Ring Output

Example 3

Tilt acceleration normalized to a peak value of 5 to allow the peak acceleration signal to be associated with a phase angle (for analysis purposes only)

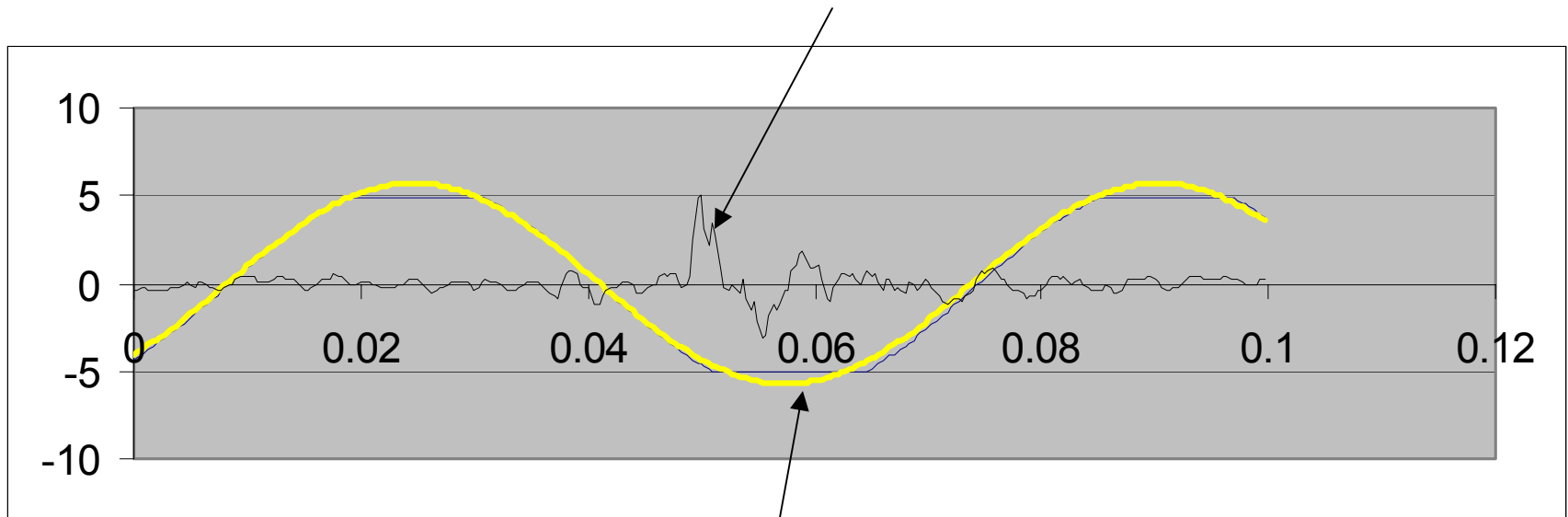

Slip Ring Output

Example 4

Tilt acceleration normalized to a peak value of 5 to allow the peak acceleration signal to be associated with a phase angle (for analysis purposes only)

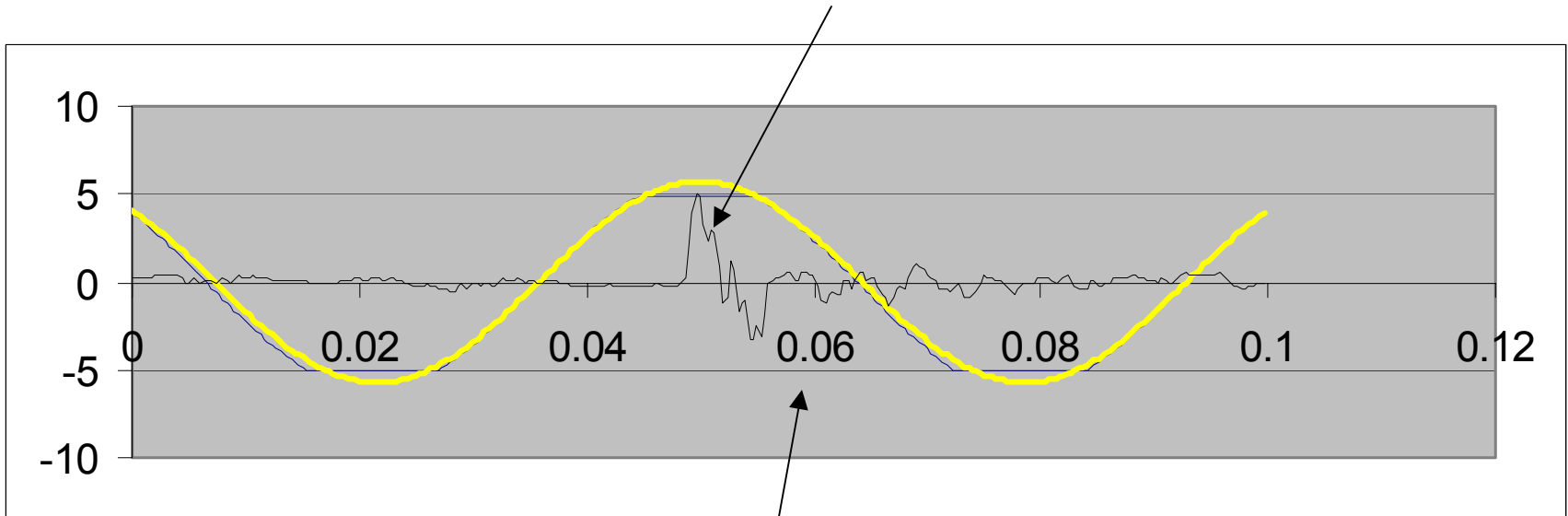

Slip Ring Output

Example 5

Tilt acceleration normalized to a peak value of 5 to allow the peak acceleration signal to be associated with a phase angle (for analysis purposes only)

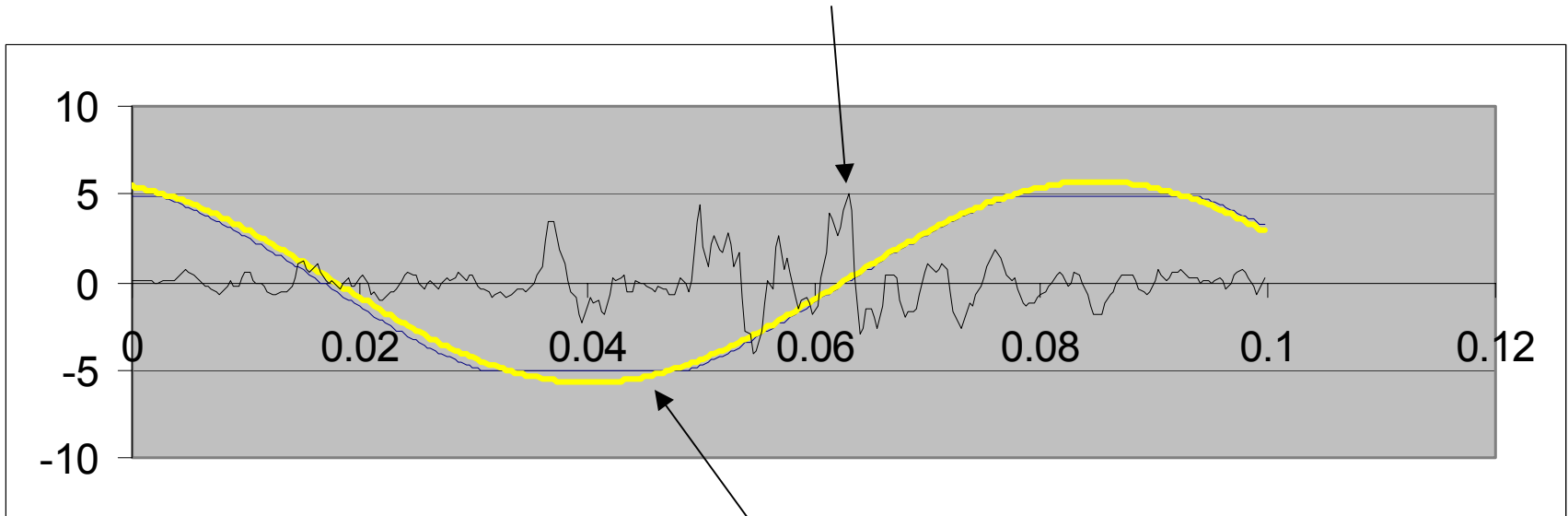

Slip Ring Output

Example 6

Tilt acceleration normalized to a peak value of 5 to allow the peak acceleration signal to be associated with a phase angle (for analysis purposes only)

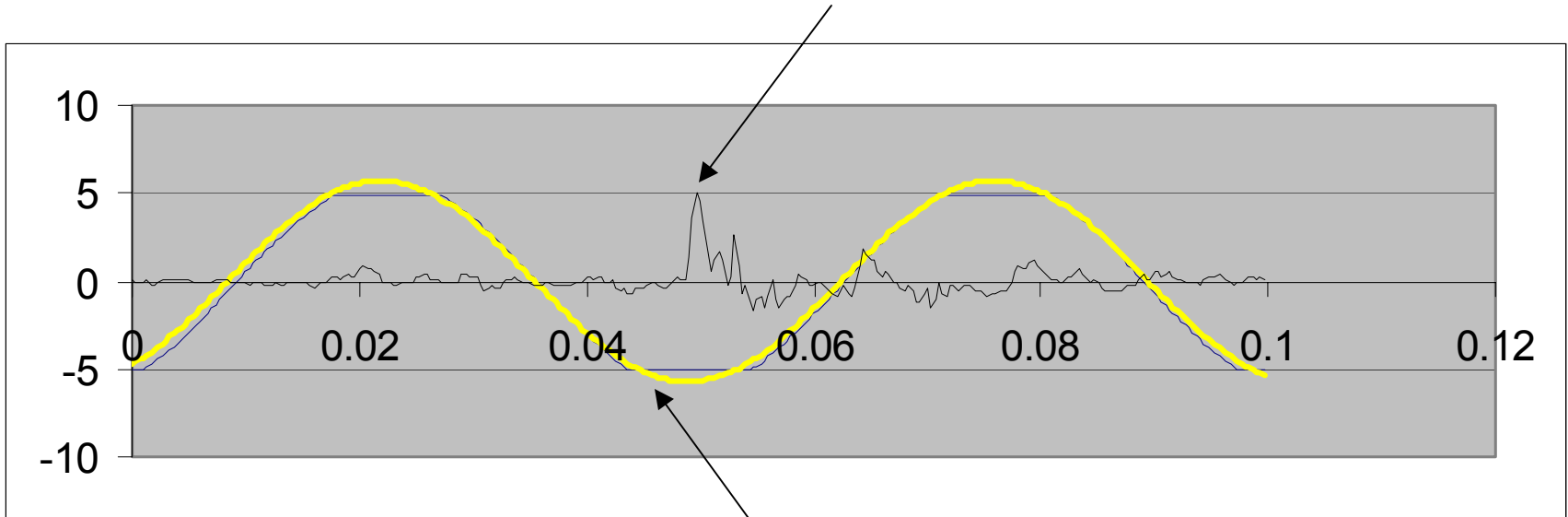

Slip Ring Output

BOP Strains Recorded on Spoke 6 of Center WABTEC/SAB-WABCO Disc - May 26, 2005

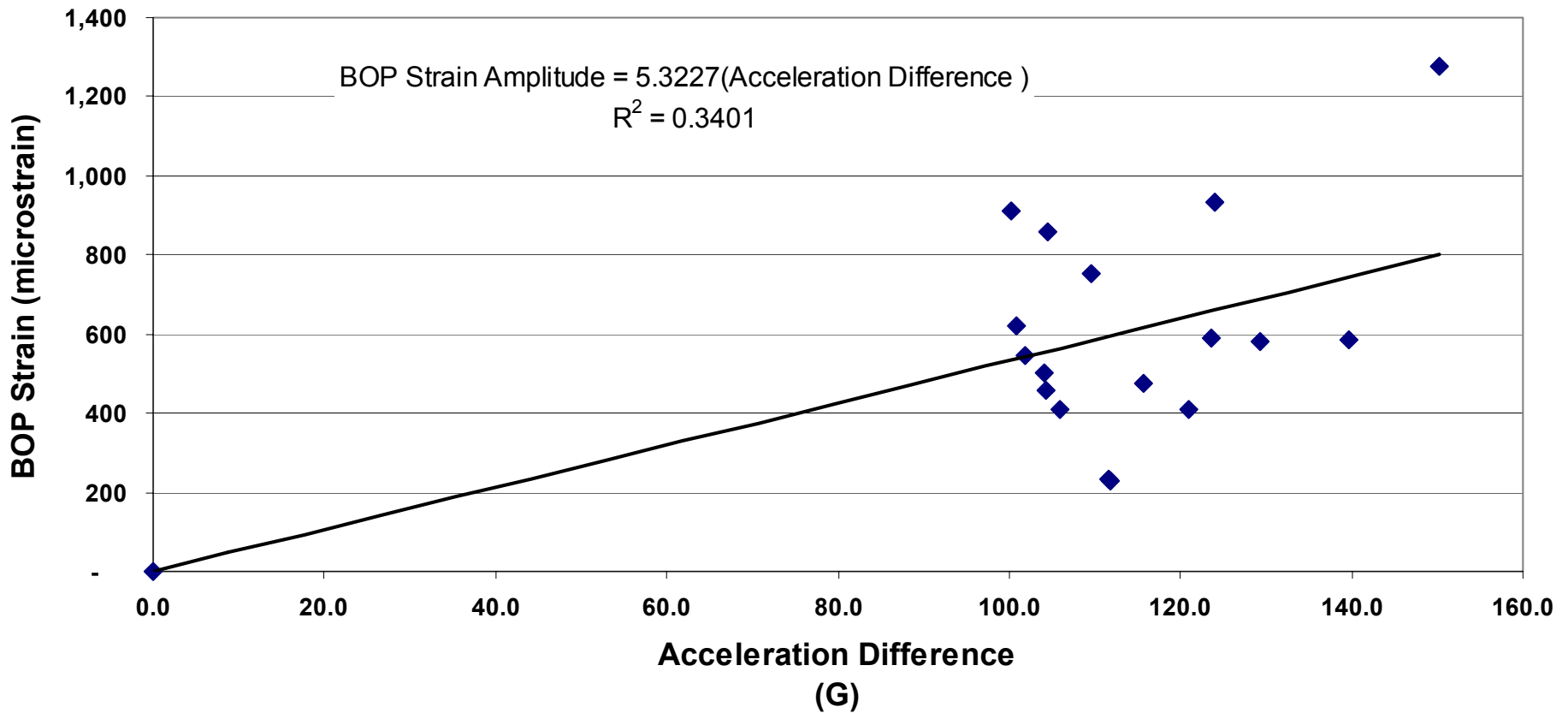

BOP Strains Recorded on Spoke 6 of Center WABTEC/SAB-WABCO Disc - May 26, 2005

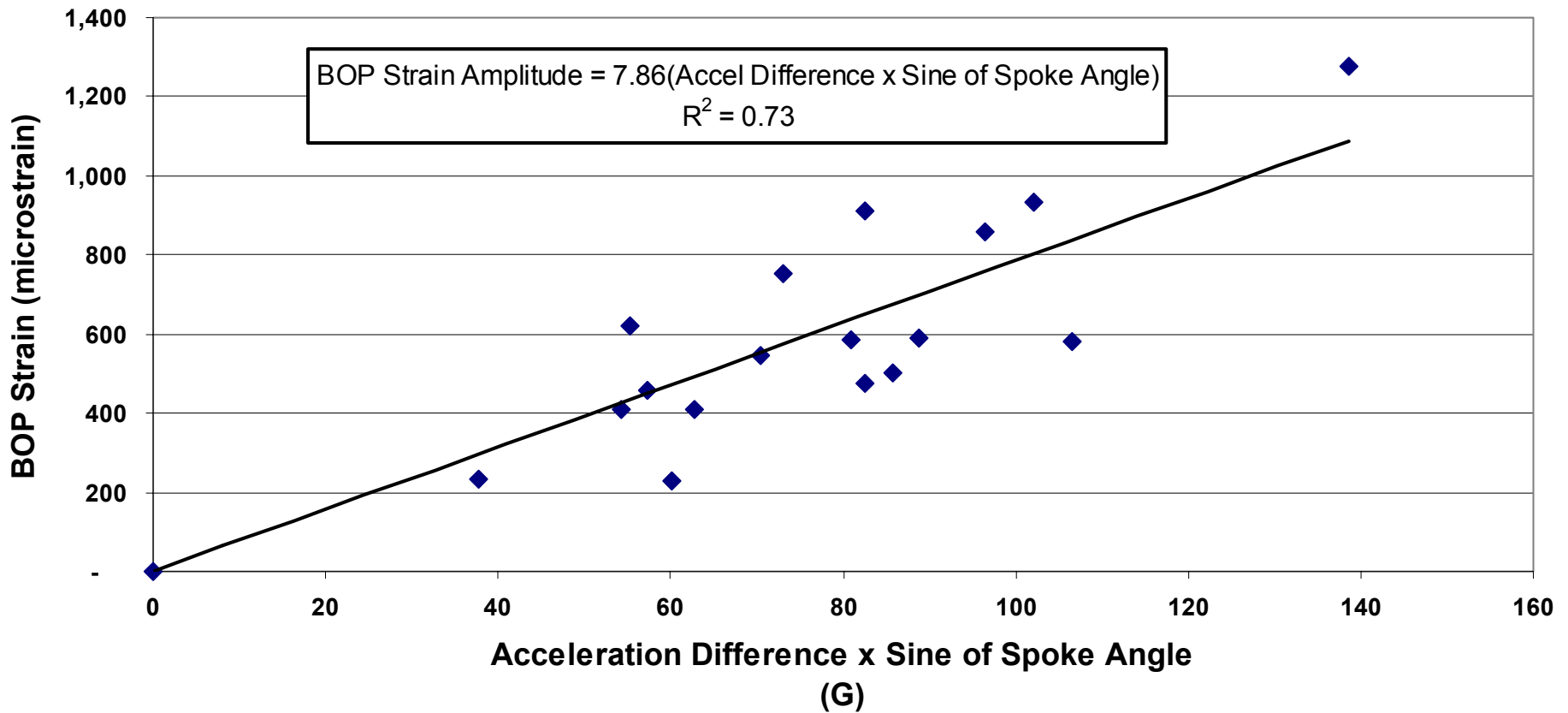

Conclusions

- The BOP Response To Single Track Related Acceleration Pulses Are Proportional To The Level of Acceleration Differences And The Sine Of The Spoke Angular Position
- Based On The Limited Sample

$$\text{BOP} = 7.5 \text{ Tilt Sin (Spoke Angle)}$$

Comparison of Response of WABTEC/SAB-WABCO and Knorr Brake Discs

Table F.4. Statistics, Axle 1, 6/17/2005

Min	Max	Mean	Stdev	RMS	Channel
-213.8	170.8	-0.1	1.2	1.5	CH01_AXLELAT1-1
-15.8	11.6	0.0	0.7	0.5	CH02_02_TRFLLAT1
-18.4	24.0	0.0	0.7	0.6	CH03_TRFLVERT1
-11.8	18.8	0.0	0.6	0.3	CH04_TRFLLONG1
-9.1	8.5	0.0	0.5	0.2	CH05_BRMTLAT1
-9.0	10.4	0.0	0.6	0.3	CH06_BRMTVERT1
-12.9	15.6	0.0	0.5	0.3	CH09_BRMTLONG1
-53.4	48.6	0.0	1.1	1.3	CH10_CTRCALPLAT1
-31.1	31.3	0.2	0.9	0.8	CH11_CTRCALPVERT1
-17.1	16.6	0.1	0.5	0.3	CH12_CTRCALPLONG1
-42.6	58.5	0.0	0.8	0.6	CH54_LBOXLAT1
-73.5	188.9	0.0	1.2	1.5	CH55_LBOXVERT1
-51.4	39.3	0.0	0.8	0.6	CH56_RBOXLAT1
-58.7	150.2	0.0	1.3	1.6	CH57_RBOXVERT1

Table F.5. Statistics, Axle 1, 6/17/2005

Min	Max	Mean	Stdev	RMS	Channel
-31.9	39.0	-0.1	0.8	0.6	CH16_AXLELAT2
-15.9	17.3	0.0	0.8	0.6	CH17_TRFLLAT2
-17.3	23.8	0.0	0.8	0.6	CH18_TRFLVERT2
-13.7	25.4	0.0	0.6	0.4	CH19_TRFLLONG2
-8.4	7.6	0.0	0.5	0.2	CH20_BRMTLAT2
-10.6	12.2	0.0	0.5	0.3	CH21_BRMTVERT2
-12.9	10.5	0.0	0.5	0.3	CH22_BRMTLONG2
-44.8	39.7	-0.1	0.6	0.3	CH23_CTRCALPLAT2
-31.5	26.2	0.0	0.7	0.5	CH24_CTRCALPVERT2
-14.9	12.8	0.2	0.5	0.3	CH25_CTRCALPLONG2
-124.4	122.3	0.0	1.4	2.1	CH58_LBOXLAT2
-64.4	171.6	0.0	1.3	1.6	CH59_LBOXVERT2
-86.9	155.4	0.0	1.3	1.7	CH60_RBOXLAT2
-69.2	152.3	0.0	1.2	1.5	CH61_RBOXVERT2

Locations for the Following Plots

Day	File	Time of File (sec)	Speed (mph)	Brake Pressure (psi)	BOP
6/18	24	310	110	56	No
6/18	24	581	106	56	Yes
6/18	30	732	125	0	Yes

Axle Acceleration Examples

- June 18, 2005 File 24, t = 310–No BOP, Braking
- June 18, 2005 File 24, t = 581–BOP, Braking
- June 18, 2005 File 30, t=732–BOP, Response to Impact

6/18/2005–File 24

Axle Lateral Accel, blue = WABTEC/SAB-WABCO, green = Knorr

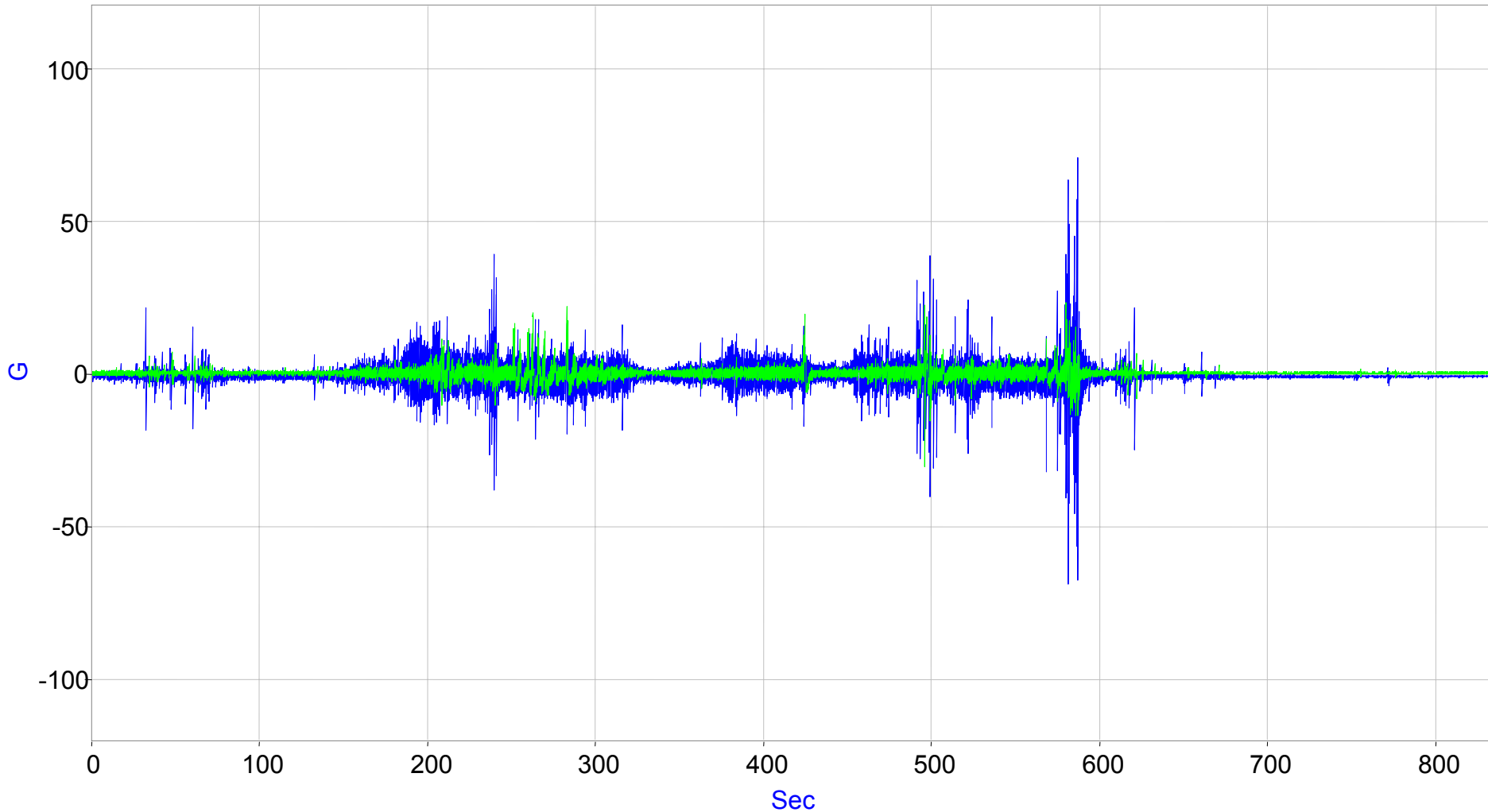

F-54

6/18/2005–File 24

Left Box Lateral Accel, blue = WABTEC/SAB-WABCO, green = Knorr

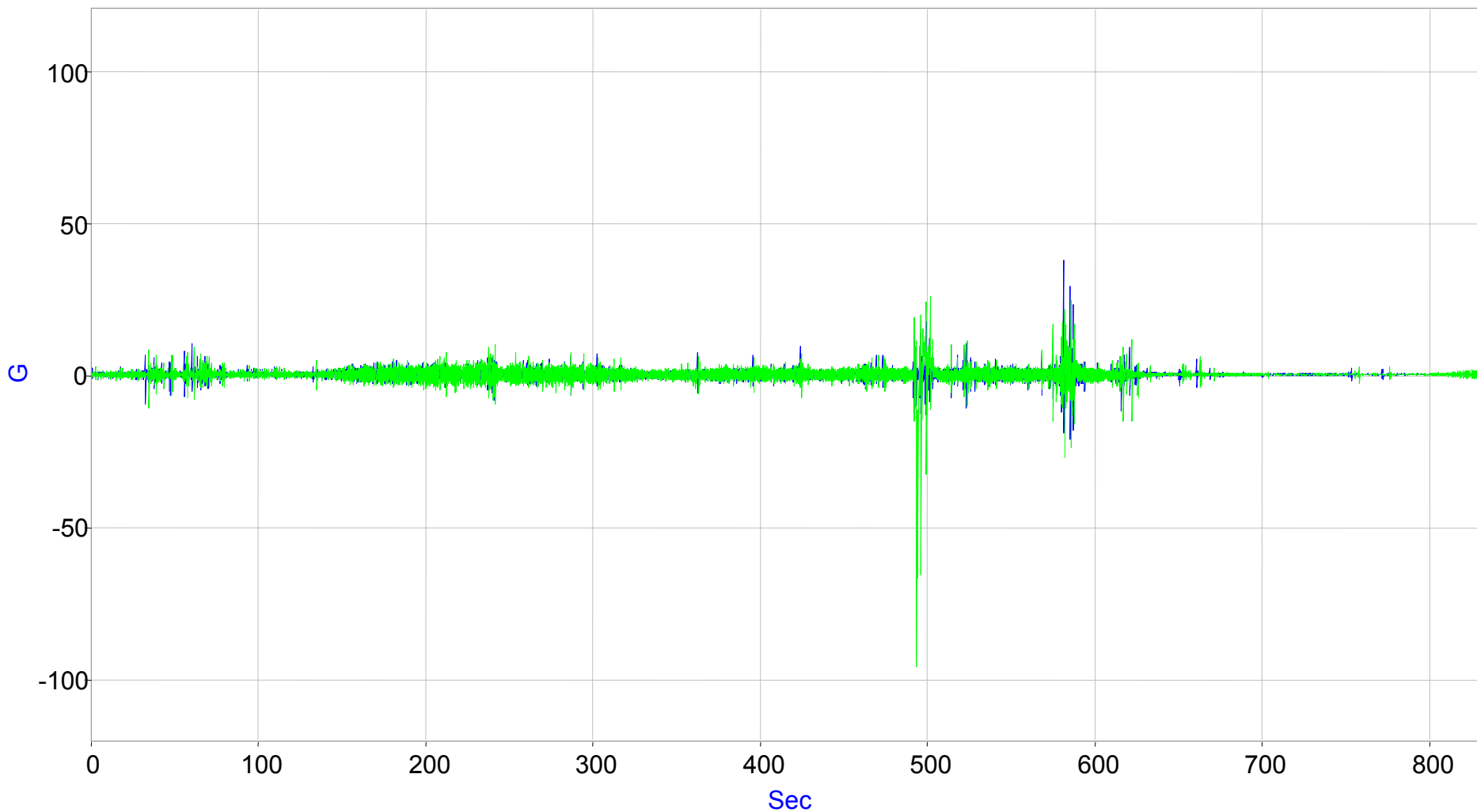

F-55

6/18/2005–File 24

Left Box Vertical Accel, blue = WABTEC/SAB-WABCO, green = Knorr

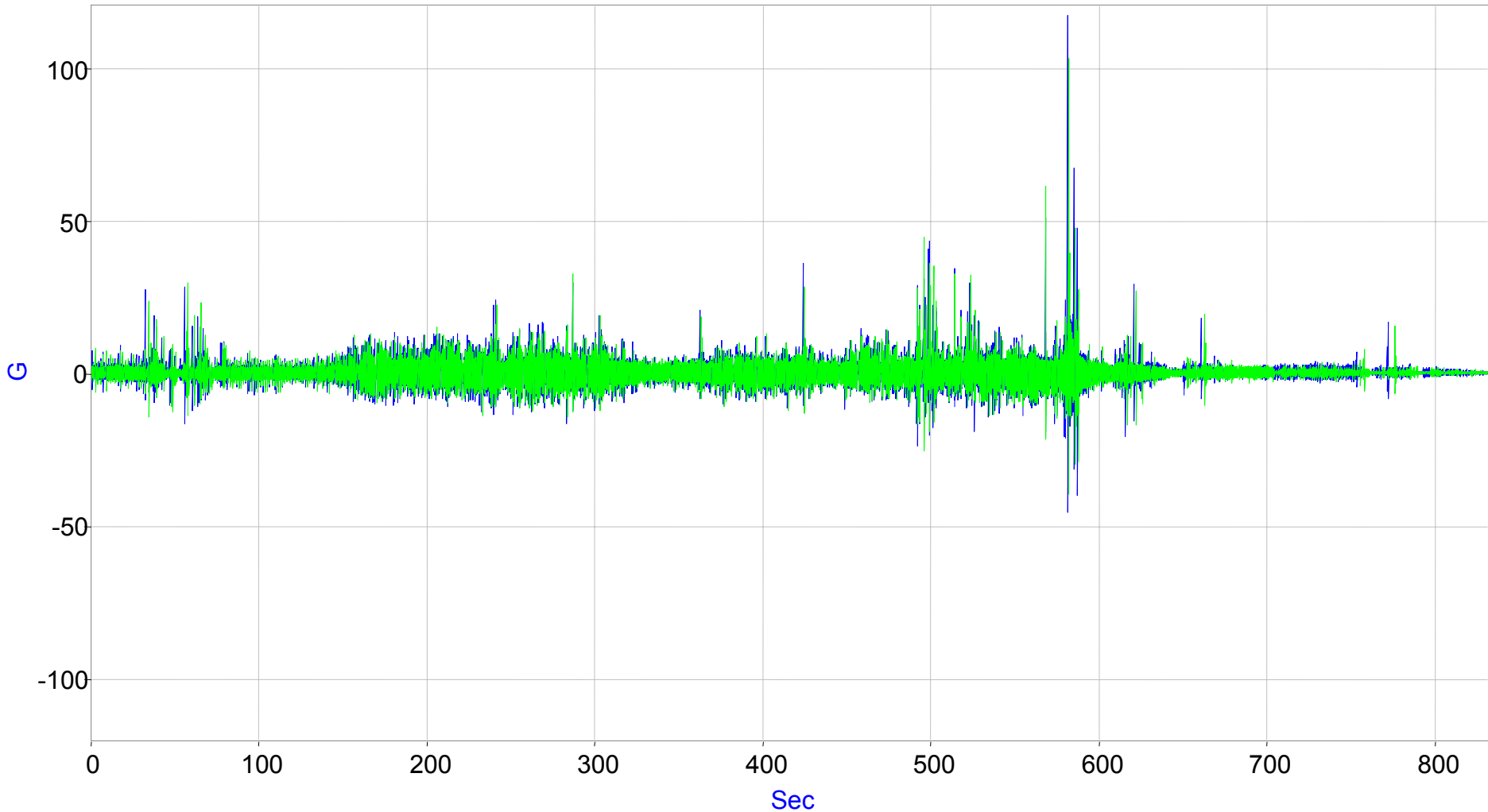

F-56

6/18/2005–File 24 (Brake, No SO)

Axle Lateral Accel, blue = WABTEC/SAB-WABCO, green = Knorr

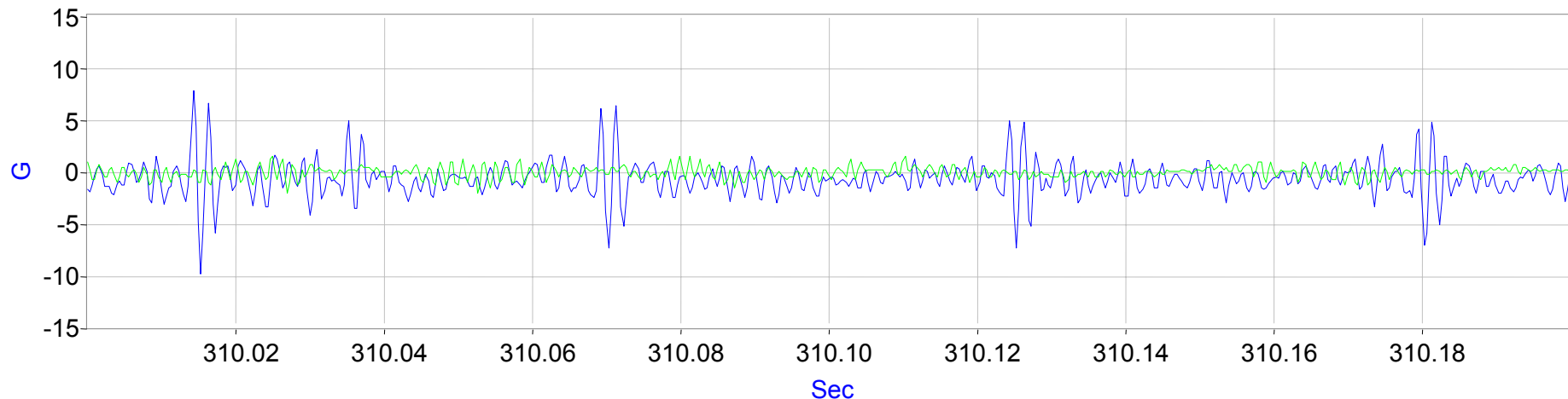

PSD of Axle Lateral Accel, 16384 points, 5 point moving avg, t = 310 s,
blue = WABTEC/SAB-WABCO, green = Knorr

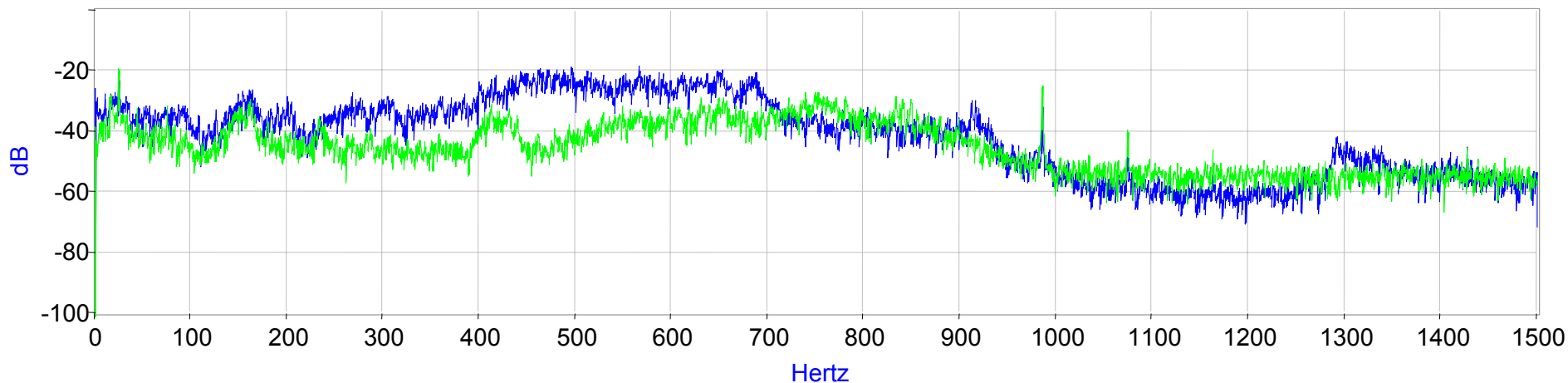

6/18/2005–File 24 (Brake, No SO)

Left Box Lateral Accel, blue = WABTEC/SAB-WABCO, green = Knorr

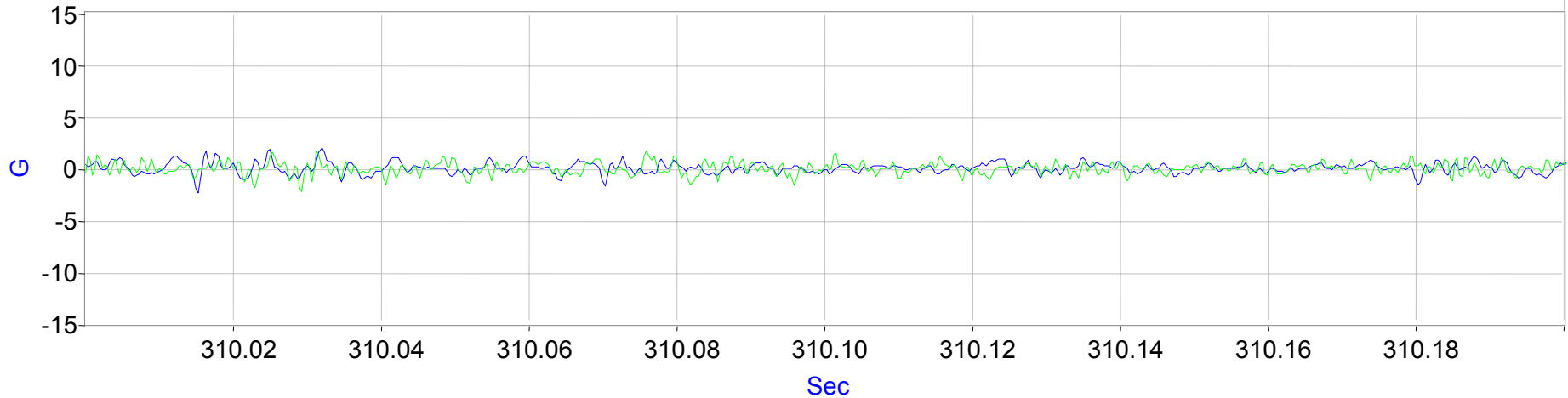

PSD of Left Box Lateral Accel, 16384 points, 5 point moving avg, t = 310 s,
blue = WABTEC/SAB-WABCO, green = Knorr

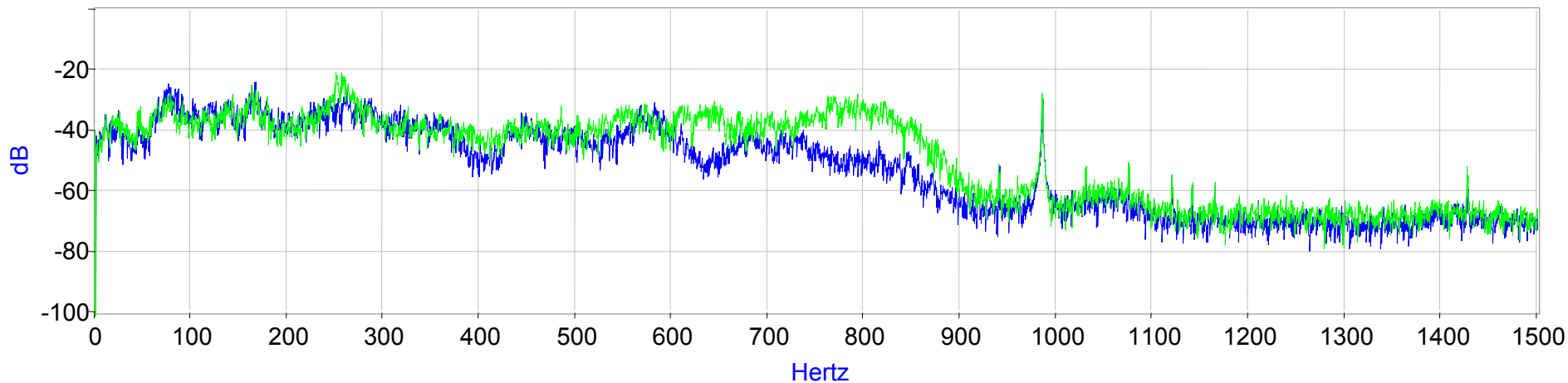

6/18/2005—File 24 (Brake, No SO)

Left Box Vertical Accel, blue = WABTEC/SAB-WABCO, green = Knorr

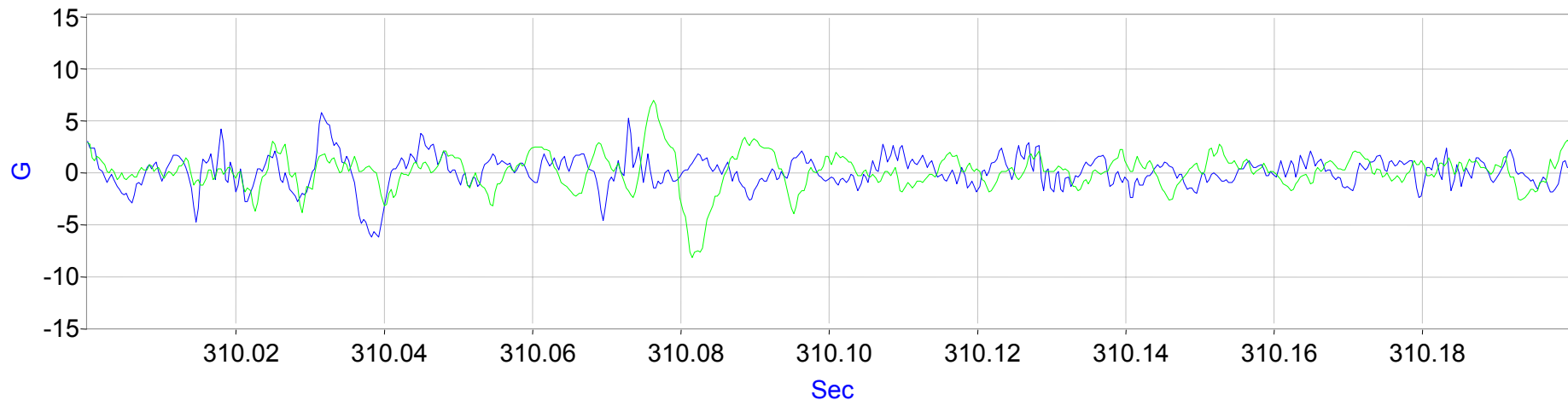

PSD of Left Box Vertical Accel, 16384 points, 5 point moving avg, t = 310 s,
blue = WABTEC/SAB-WABCO, green = Knorr

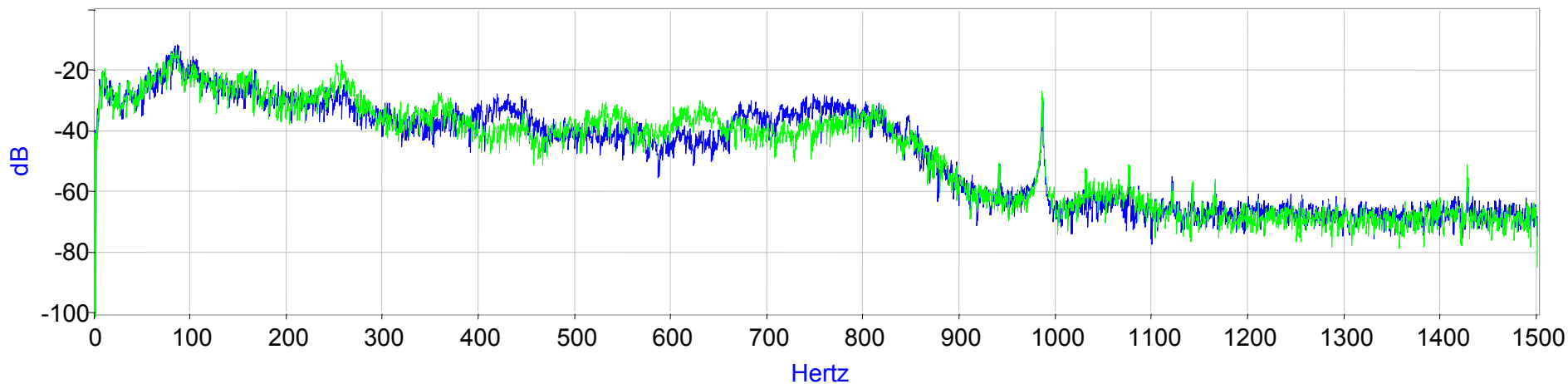

F-59

6/18/2005–File 24 (Brake, SO)

Axle Lateral Accel, blue = WABTEC/SAB-WABCO, green = Knorr

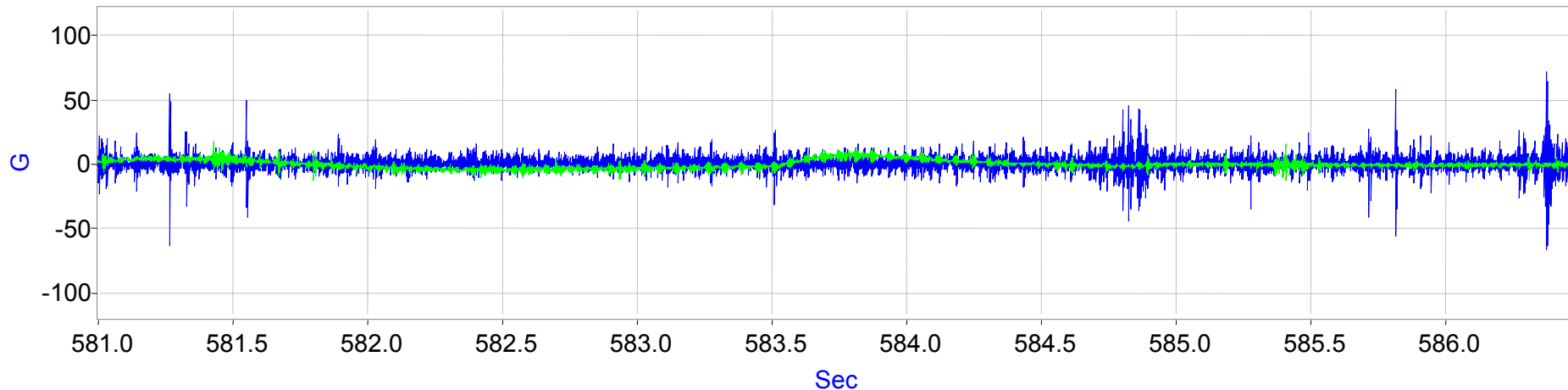

PSD of Axle Lateral Accel, 16384 points, 5 point moving avg, t = 581 s,
blue = WABTEC/SAB-WABCO, green = Knorr

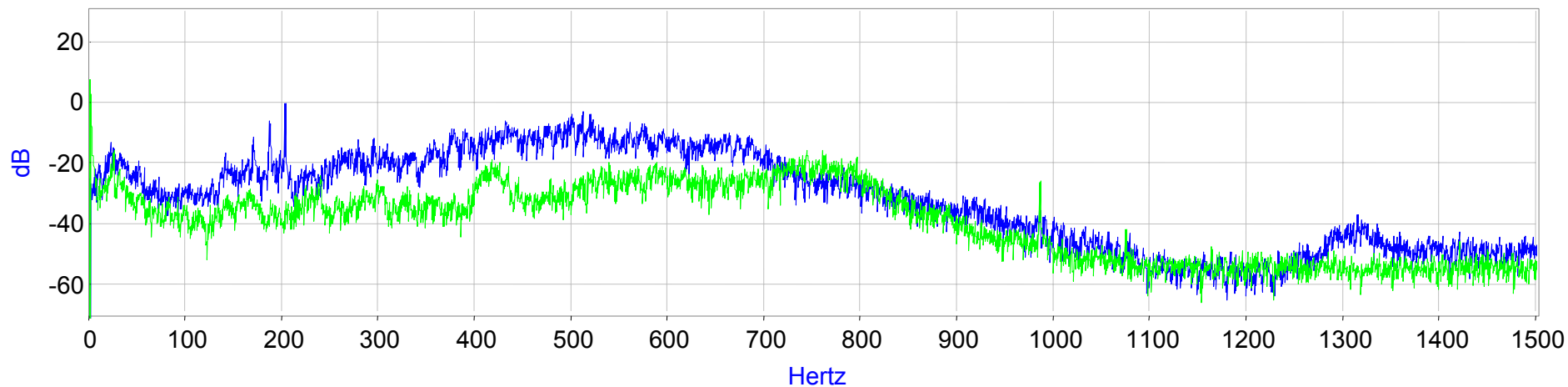

F-60

6/18/2005–File 24 (Brake, SO)

Left Box Lateral Accel, blue = WABTEC/SAB-WABCO, green = Knorr

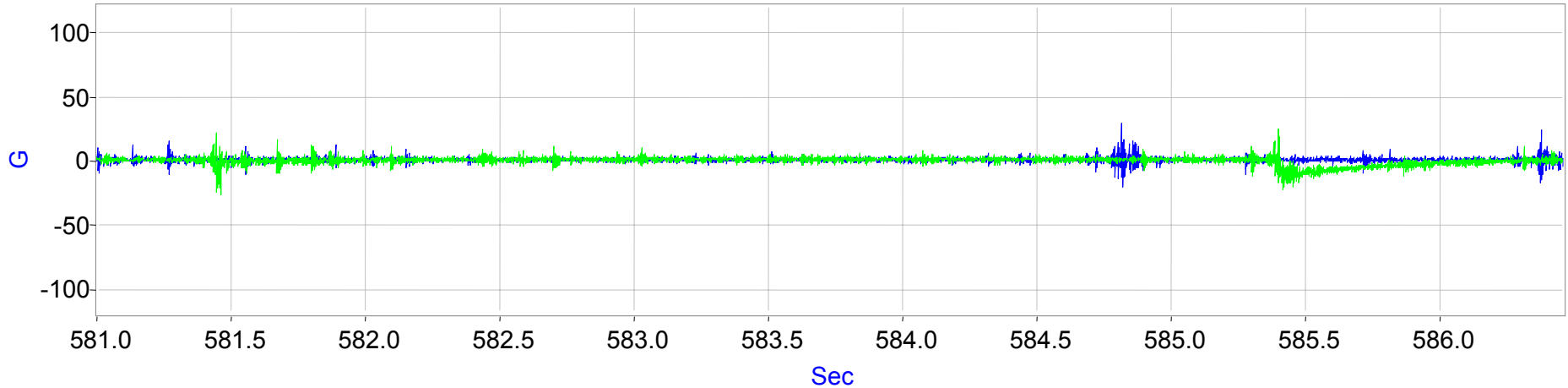

PSD of Left Box Lateral Accel, 16384 points, 5 point moving avg, t = 581 s,
blue = WABTEC/SAB-WABCO, green = Knorr

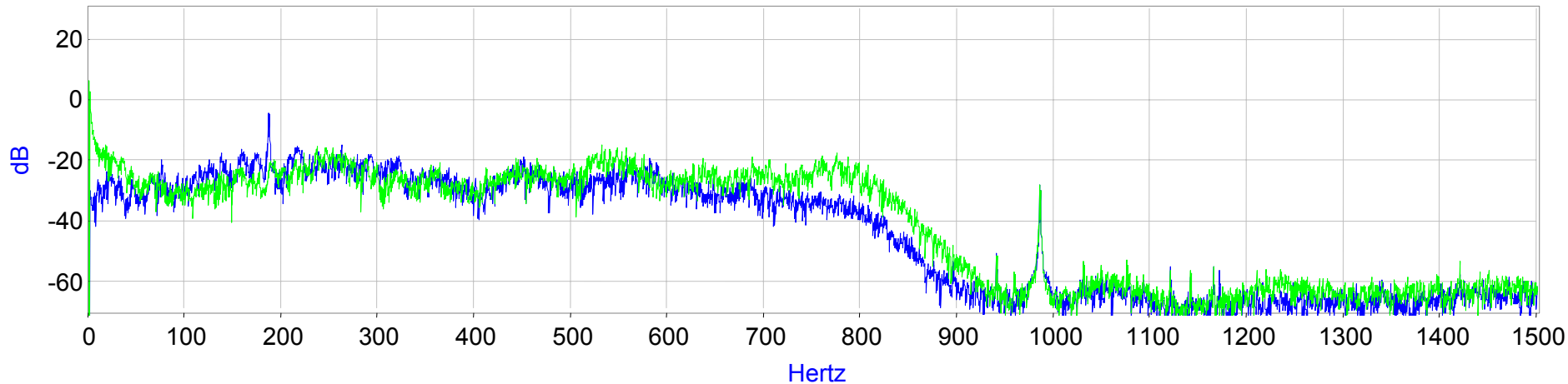

F-61

6/18/2005–File 24 (Brake, SO)

Left Box Vertical Accel, blue = WABTEC/SAB-WABCO, green = Knorr

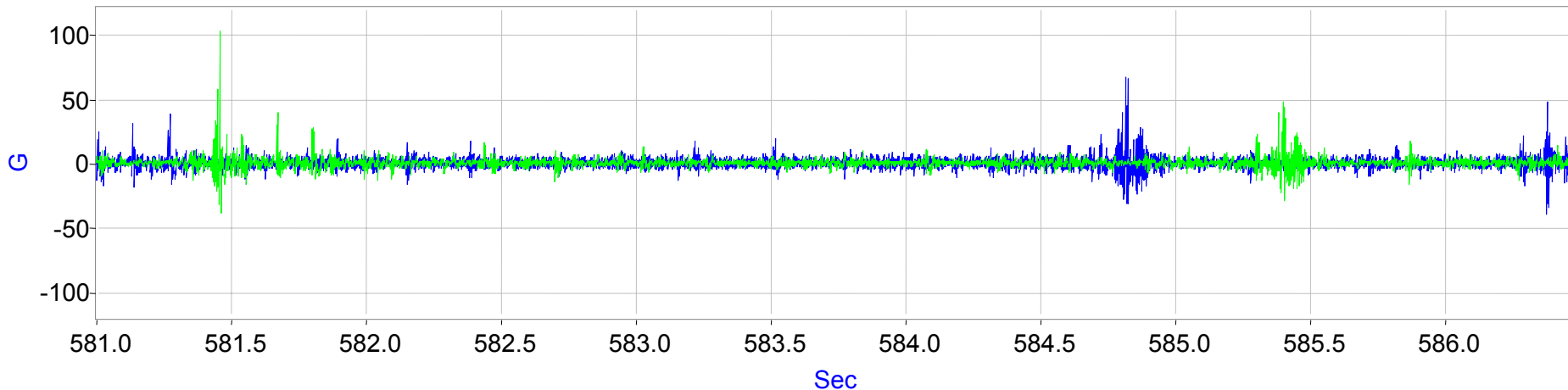

PSD of Left Box Vertical Accel, 16384 points, 5 point moving avg, t = 581 s,
blue = WABTEC/SAB-WABCO, green = Knorr

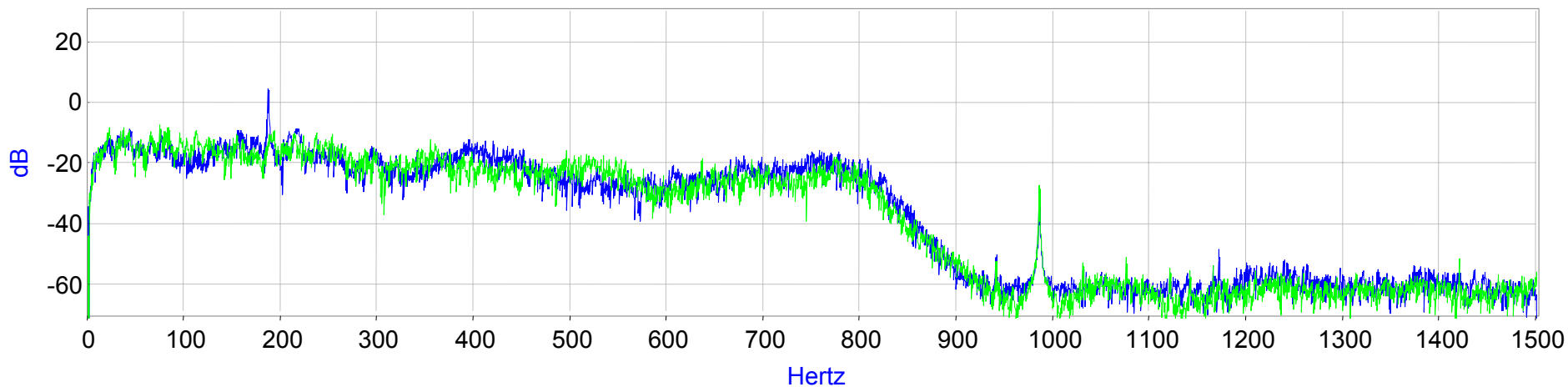

6/18/2005—File 30 (No Brake)

Axle Lateral Accel, blue = WABTEC/SAB-WABCO, green = Knorr

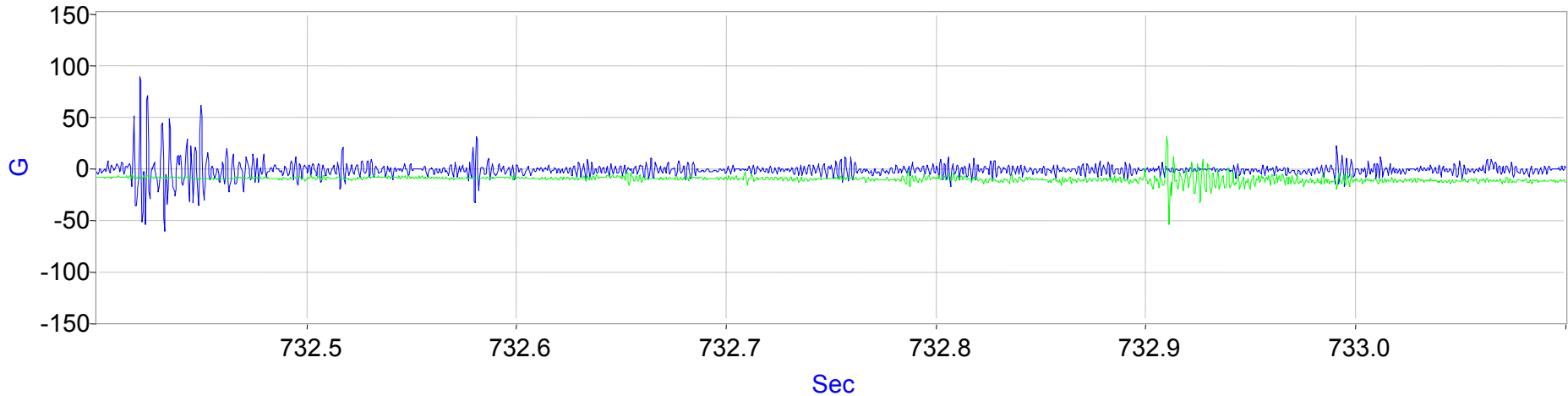

PSD of Axle Lateral Accel, 16384 points, 5 point moving avg, t = 732 s,
blue = WABTEC/SAB-WABCO, green = Knorr

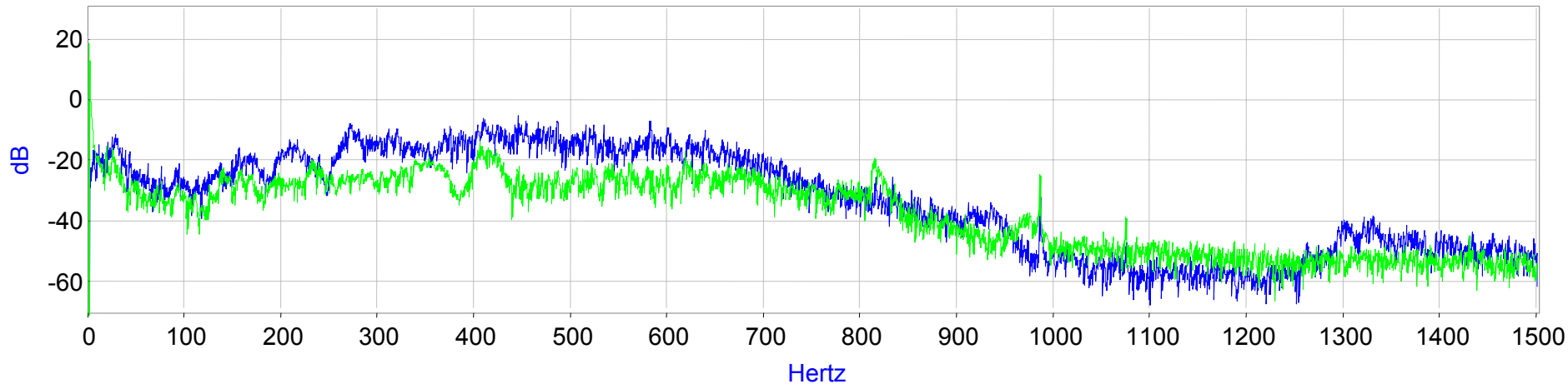

6/18/2005—File 30 (No Brake)

Left Box Lateral Accel, blue = WABTEC/SAB-WABCO, green = Knorr

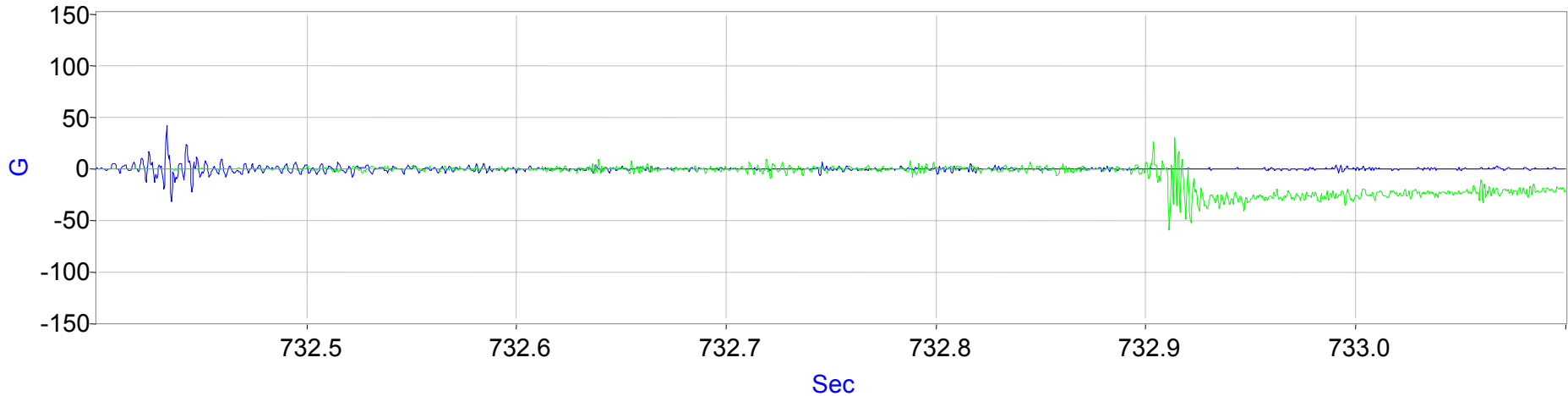

PSD of Left Box Lateral Accel, 16384 points, 5 point moving avg, t = 732 s,
blue = WABTEC/SAB-WABCO, green = Knorr

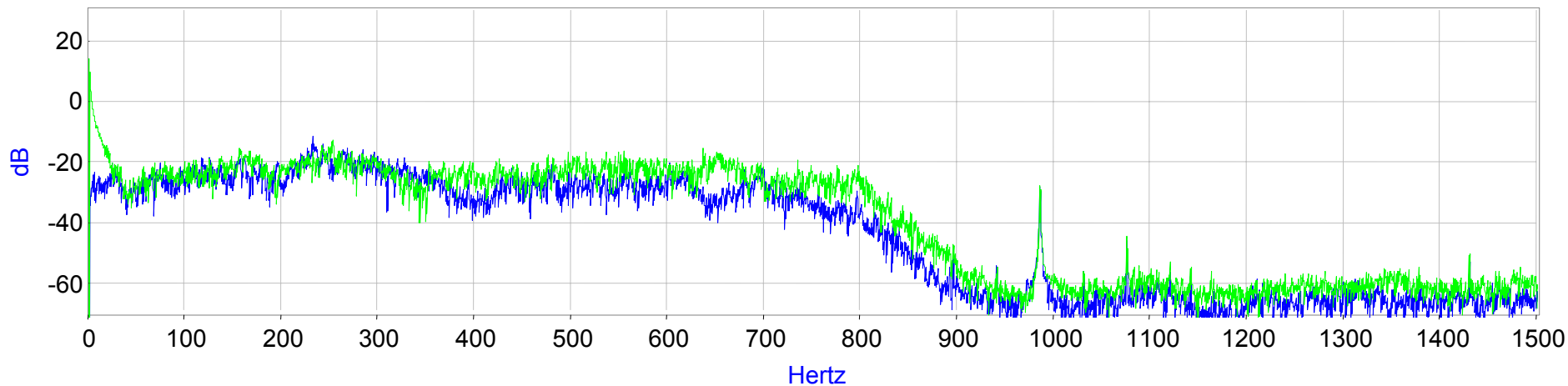

6/18/2005—File 30 (No Brake)

Left Box Vertical Accel, blue = WABTEC/SAB-WABCO, green = Knorr

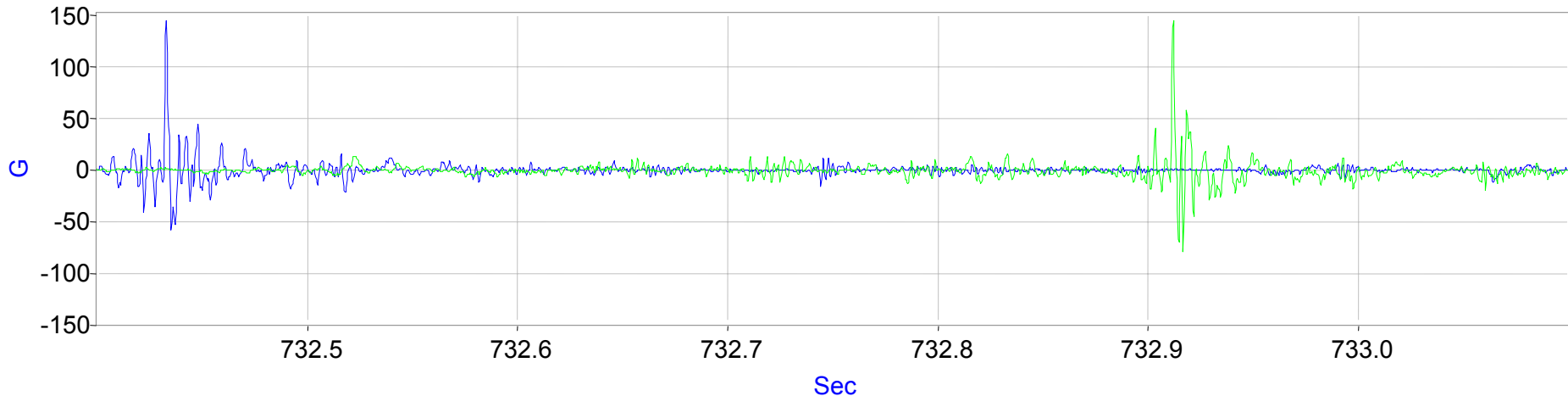

PSD of Left Box Vertical Accel, 16384 points, 5 point moving avg, t = 732 s,
blue = WABTEC/SAB-WABCO, green = Knorr

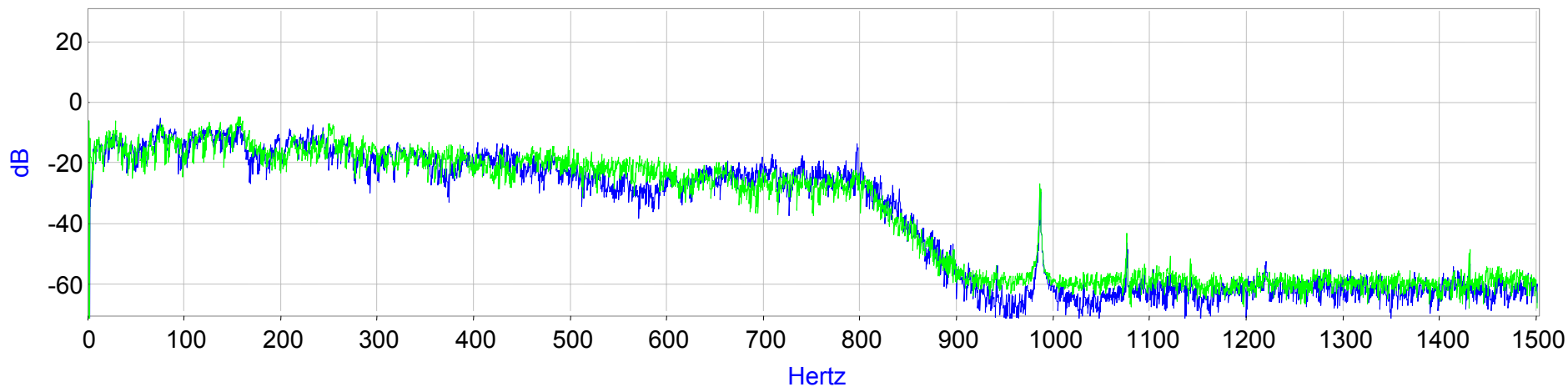

F-65

Caliper Accelerations

- June 18, 2005 File 24, t = 310–No BOP, Braking
- June 18, 2005 File 24, t = 581–BOP, Braking
- June 18, 2005 File 30, t = 732–BOP, Response to Impact

6/18/2005–File 24

Center Caliper Lateral Accel, blue = WABTEC/SAB-WABCO, green = Knorr

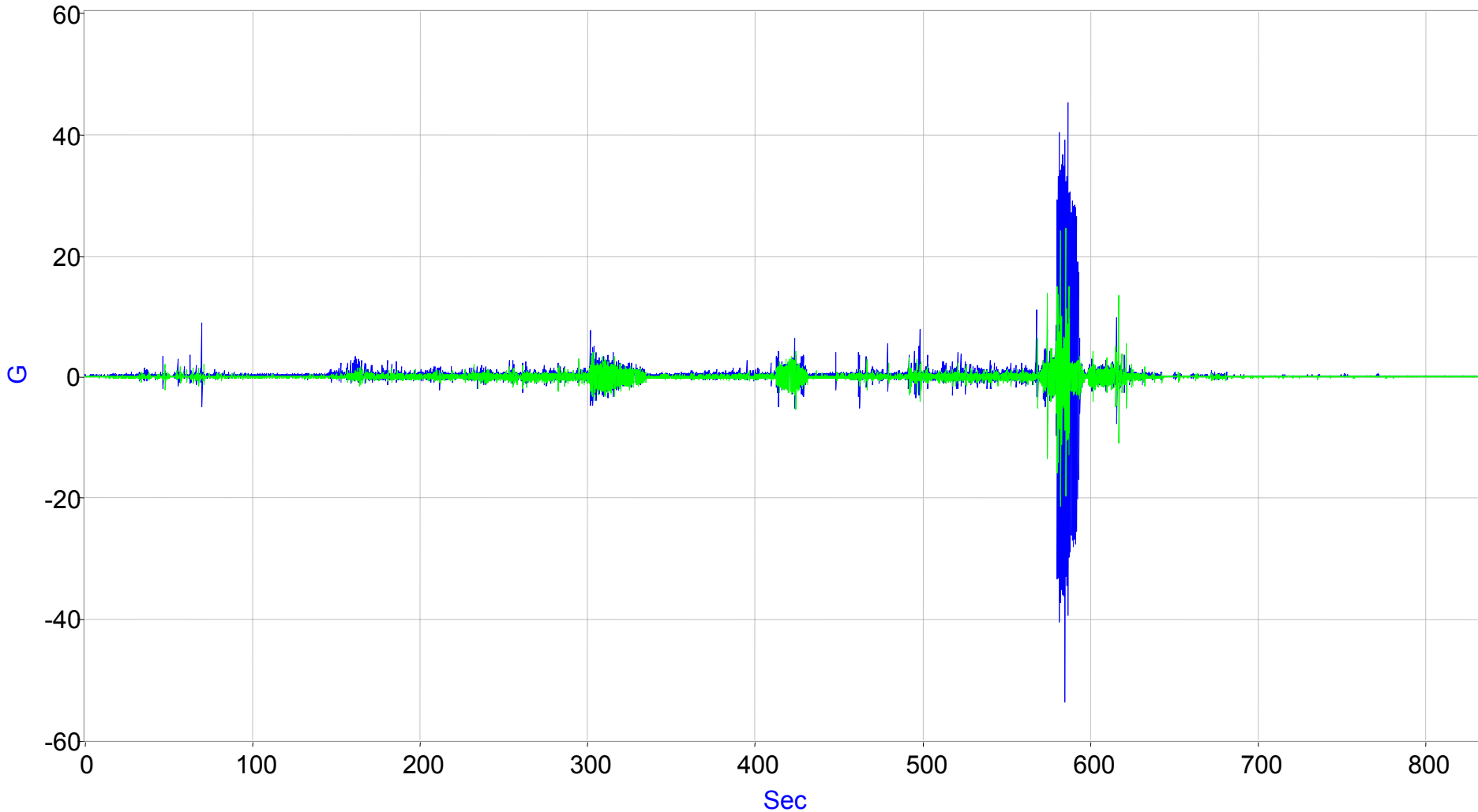

F-67

6/18/2005–File 24

Center Caliper Vertical Accel, blue = WABTEC/SAB-WABCO, green = Knorr

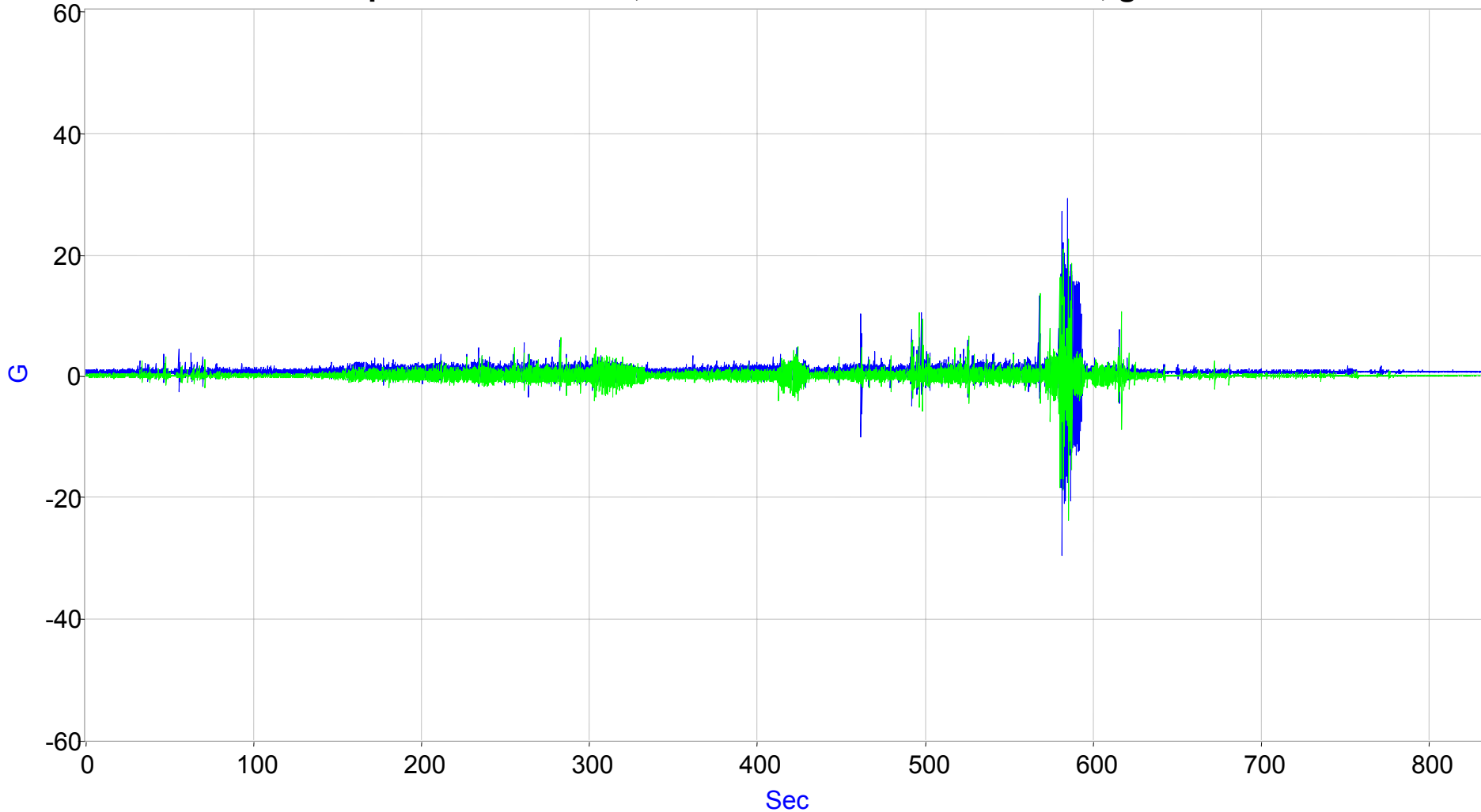

F-68

6/18/2005—File 24

Center Caliper Longitudinal Accel, blue = WABTEC/SAB-WABCO, green = Knorr

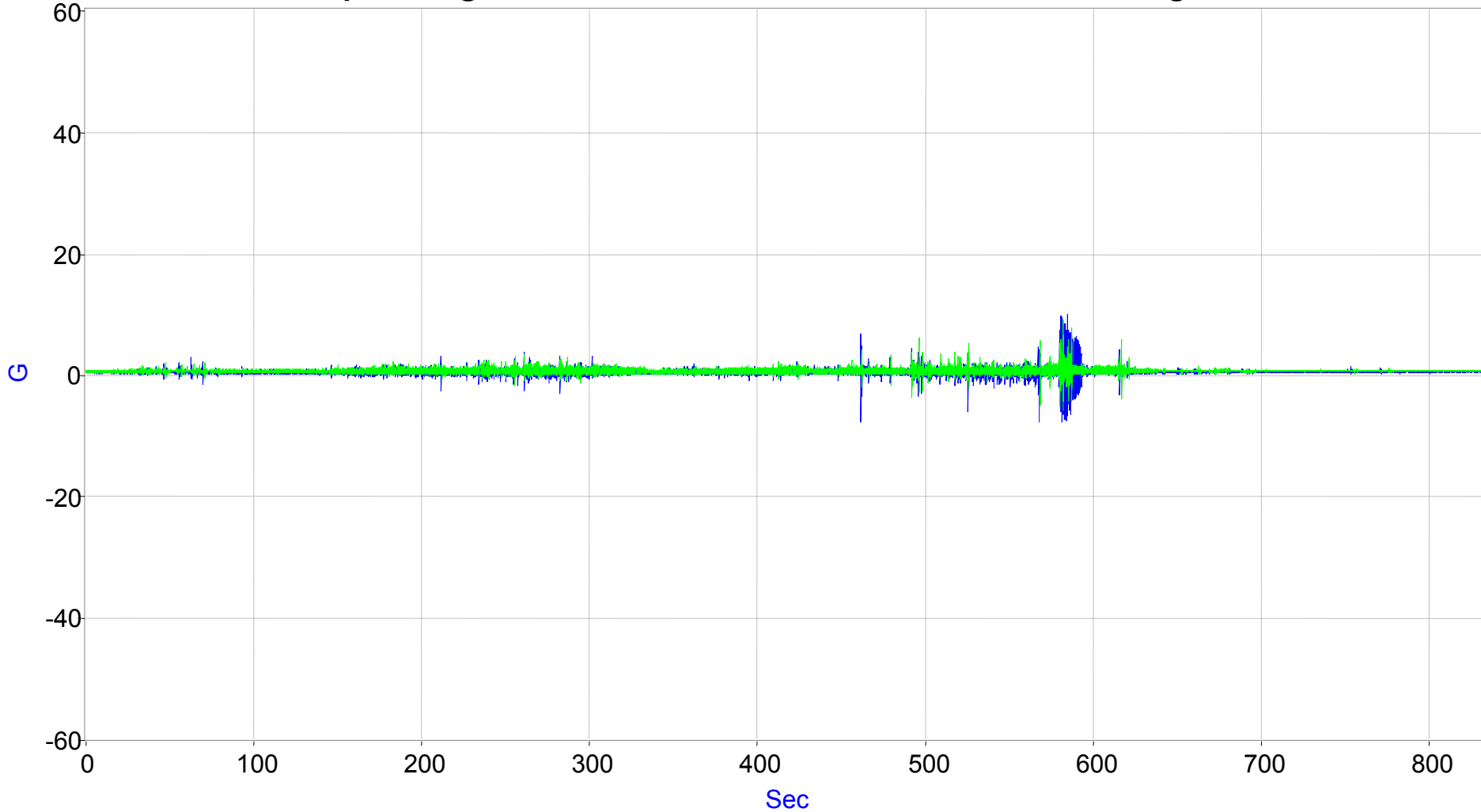

F-69

6/18/2005–File 24 (Brake, No SO)

Center Caliper Lateral Accel, blue = WABTEC/SAB-WABCO, green = Knorr

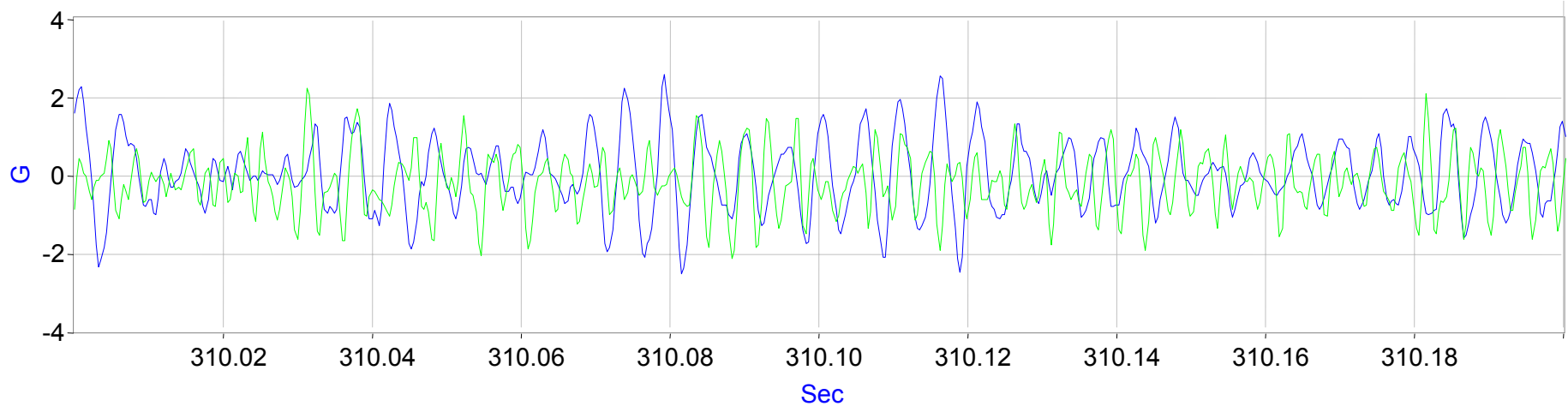

PSD of Center Caliper Lateral Accel, 16384 points, 5 point moving avg, t = 310 s,
blue = WABTEC/SAB-WABCO, green = Knorr

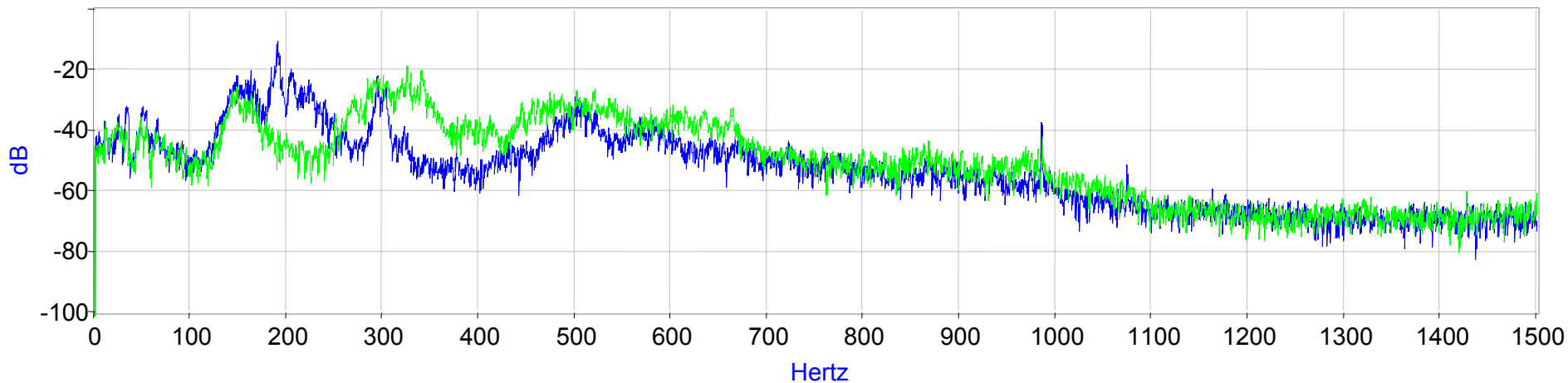

F-70

6/18/2005—File 24 (Brake, No SO)

Center Caliper Vertical Accel, blue = WABTEC/SAB-WABCO, green = Knorr

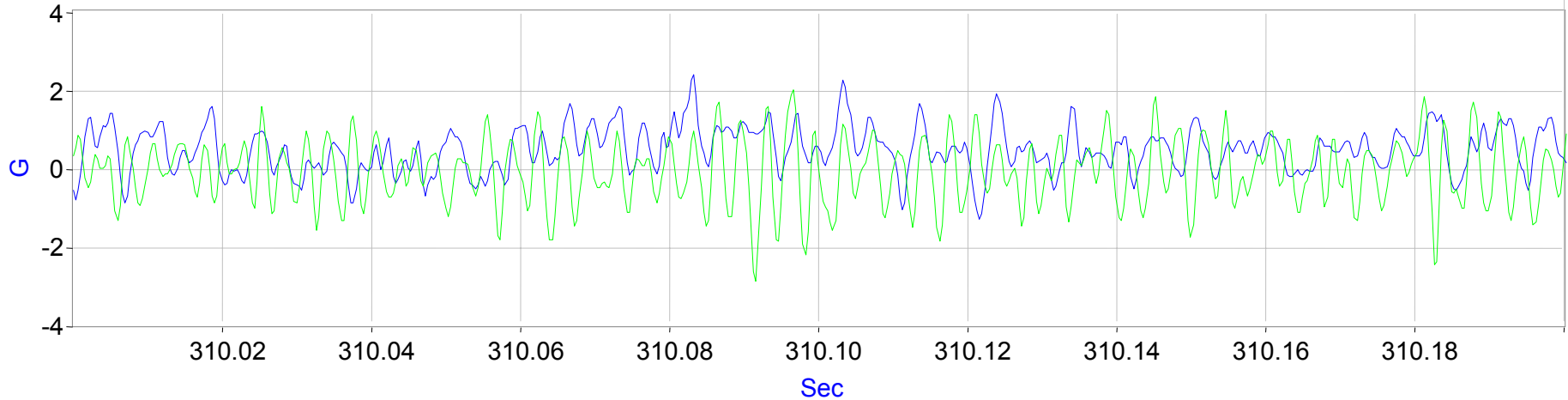

PSD of Center Caliper Vertical Accel, 16384 points, 5 point moving avg, t = 310 s,
blue = WABTEC/SAB-WABCO, green = Knorr

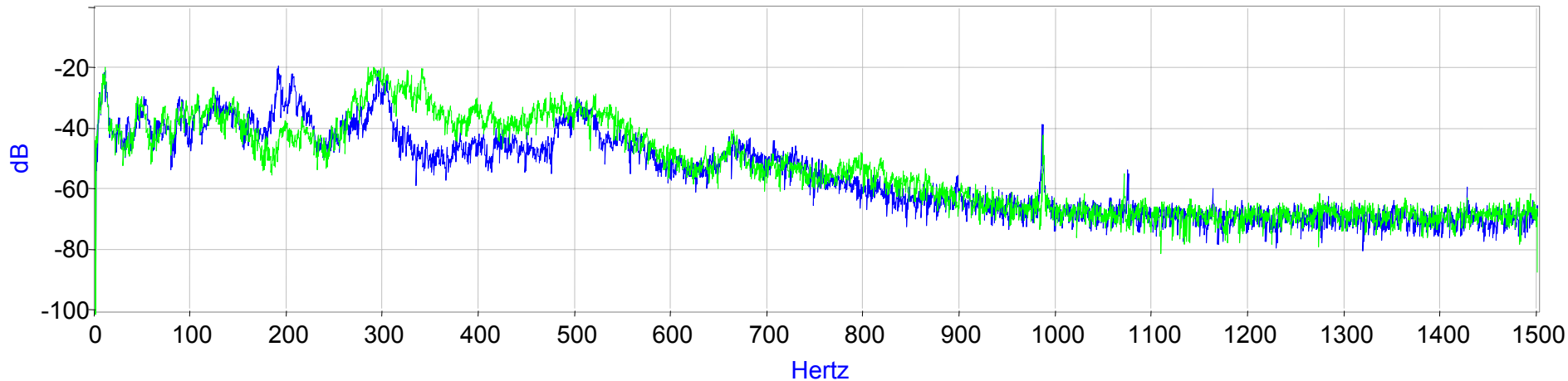

6/18/2005—File 24 (Brake, No SO)

Center Caliper Longitudinal Accel, blue = WABTEC/SAB-WABCO, green = Knorr

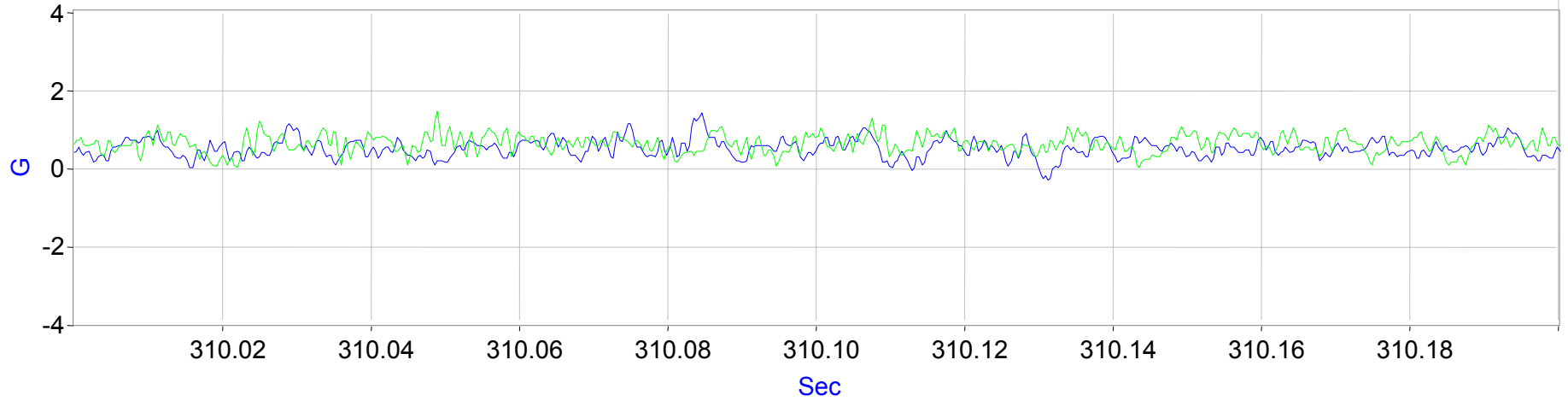

PSD of Center Caliper Longitudinal Accel, 16384 points, 5 point moving avg, t = 310 s, blue = WABTEC/SAB-WABCO, green = Knorr

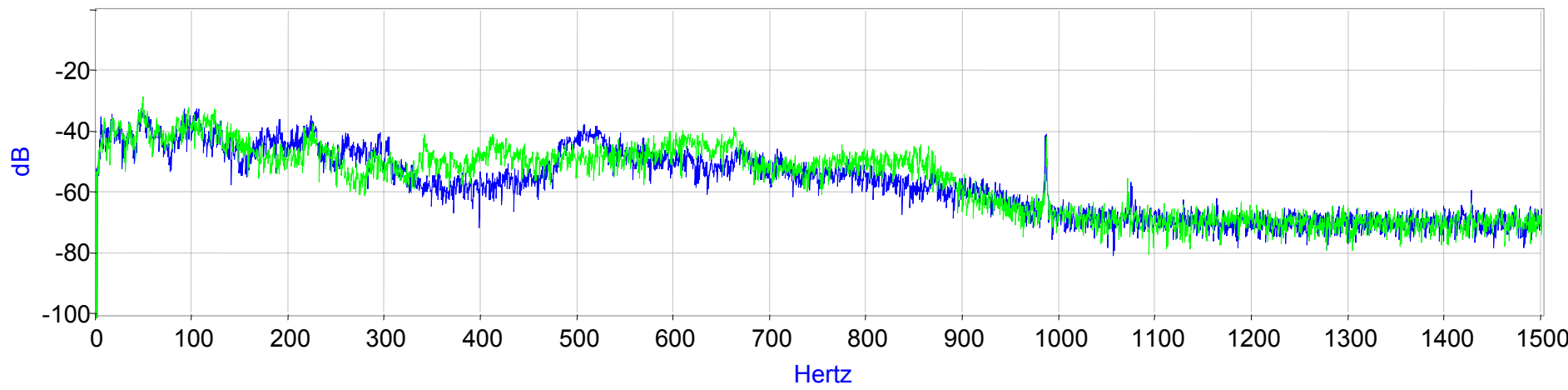

6/18/2005–File 24 (Brake, SO)

Center Caliper Lateral Accel, blue = WABTEC/SAB-WABCO, green = Knorr

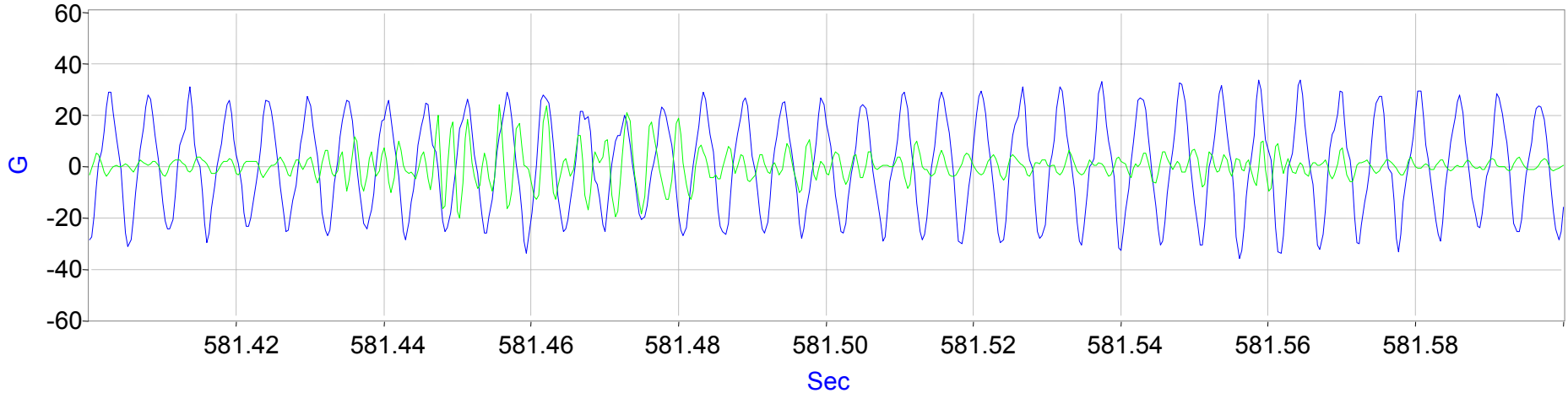

PSD of Center Caliper Lateral Accel, 16384 points, 5 point moving avg, t = 581 s,
blue = WABTEC/SAB-WABCO, green = Knorr

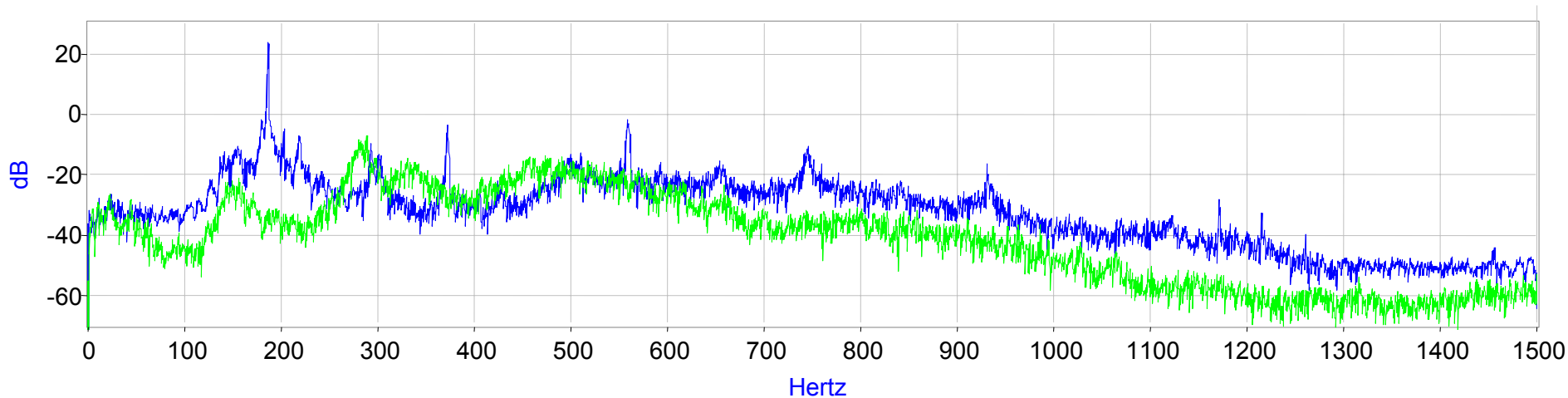

6/18/2005—File 24 (Brake, SO)

Center Caliper Vertical Accel, blue = WABTEC/SAB-WABCO, green = Knorr

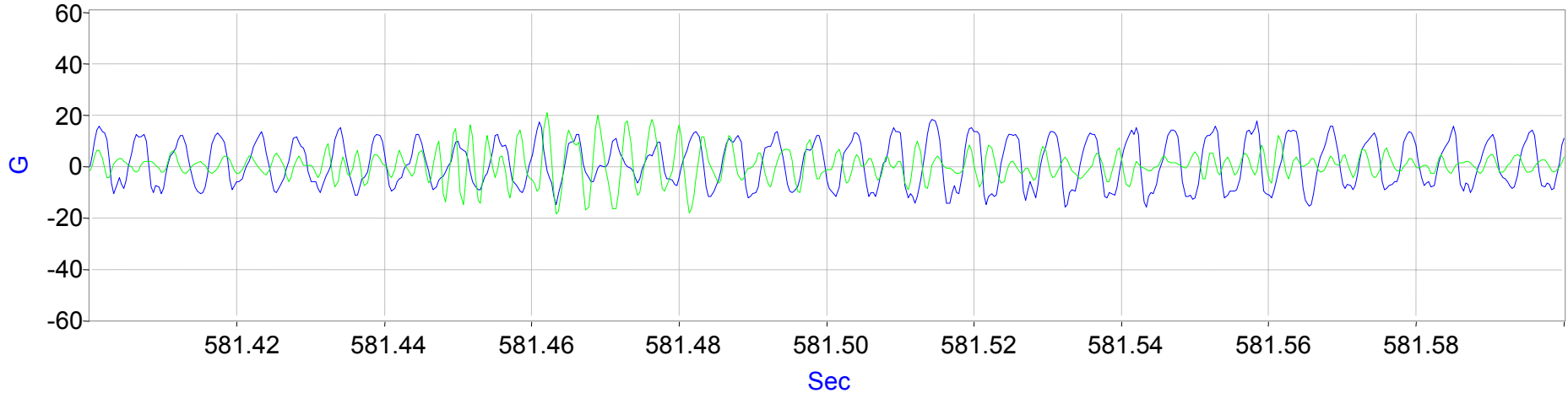

PSD of Center Caliper Vertical Accel, 16384 points, 5 point moving avg, t = 581 s,
blue = WABTEC/SAB-WABCO, green = Knorr

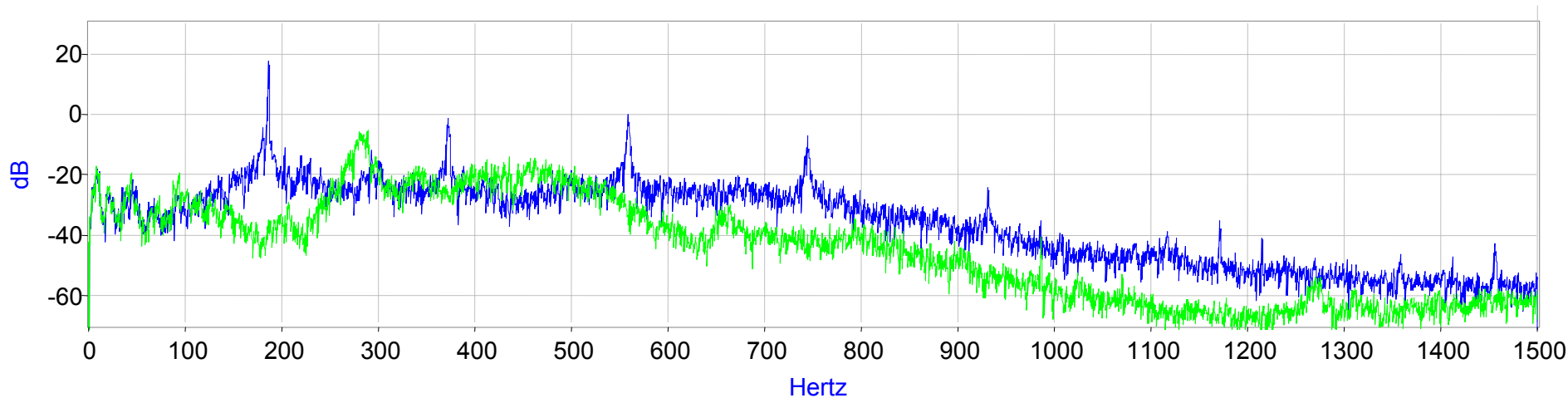

6/18/2005—File 24 (Brake, SO)

Center Caliper Longitudinal Accel, blue = WABTEC/SAB-WABCO, green = Knorr

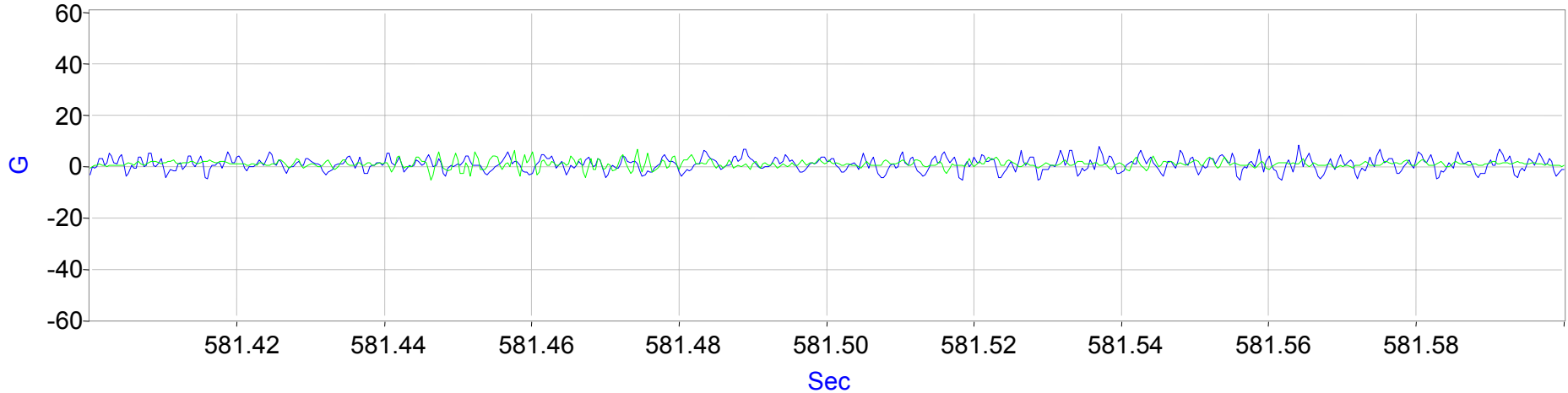

PSD of Center Caliper Longitudinal Accel, 16384 points, 5 point moving avg, t = 581 s,
blue = WABTEC/SAB-WABCO, green = Knorr

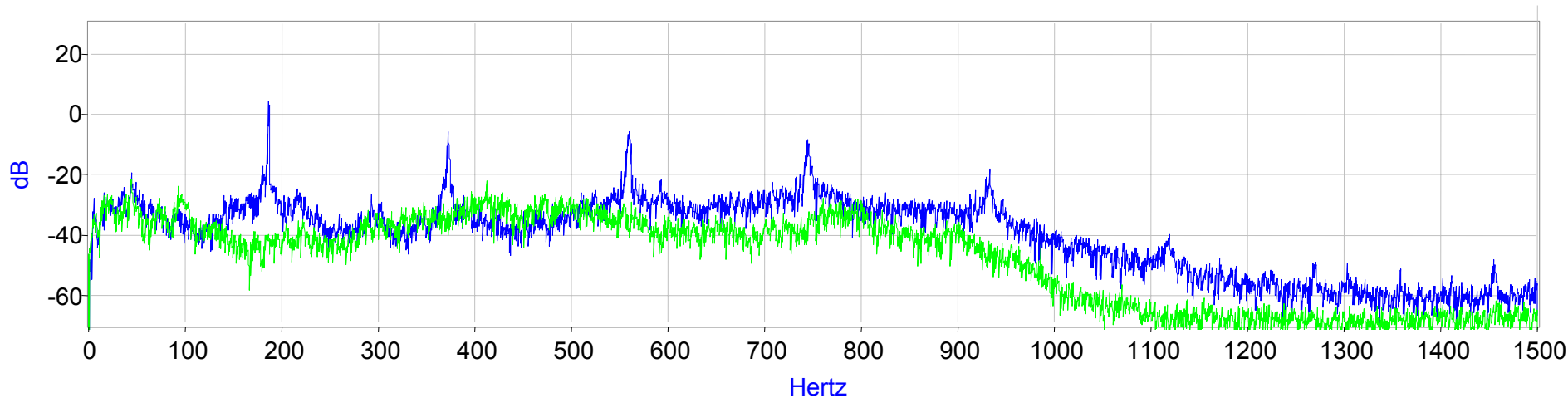

F-75

6/18/2005—File 30 (No Brake)

Center Caliper Lateral Accel, blue = WABTEC/SAB-WABCO, green = Knorr

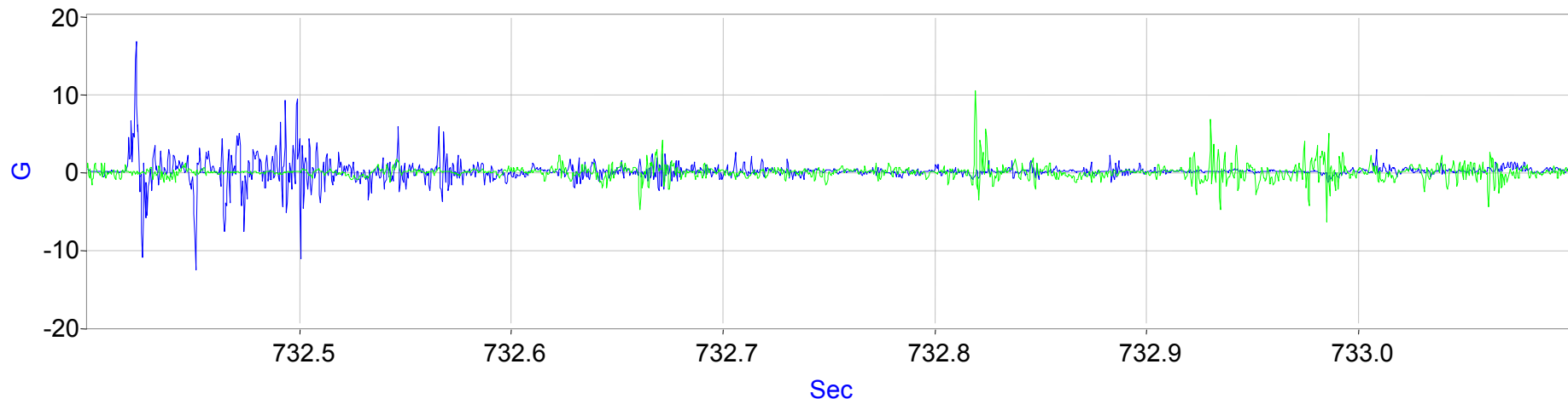

PSD of Center Caliper Lateral Accel, 16384 points, 5 point moving avg, t = 732 s,
blue = WABTEC/SAB-WABCO, green = Knorr

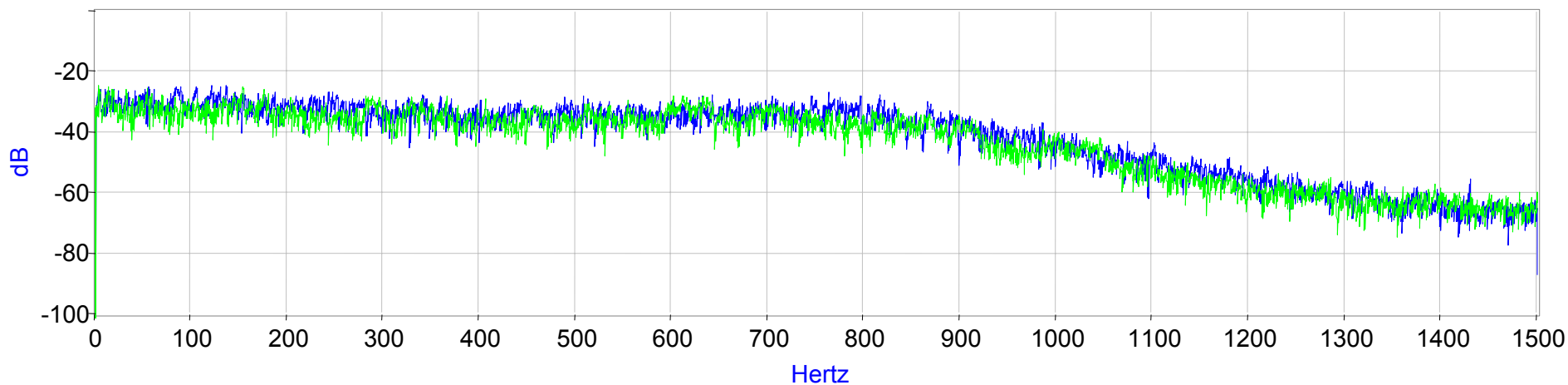

F-76

6/18/2005–File 30 (No Brake)

Center Caliper Vertical Accel, blue = WABTEC/SAB-WABCO, green = Knorr

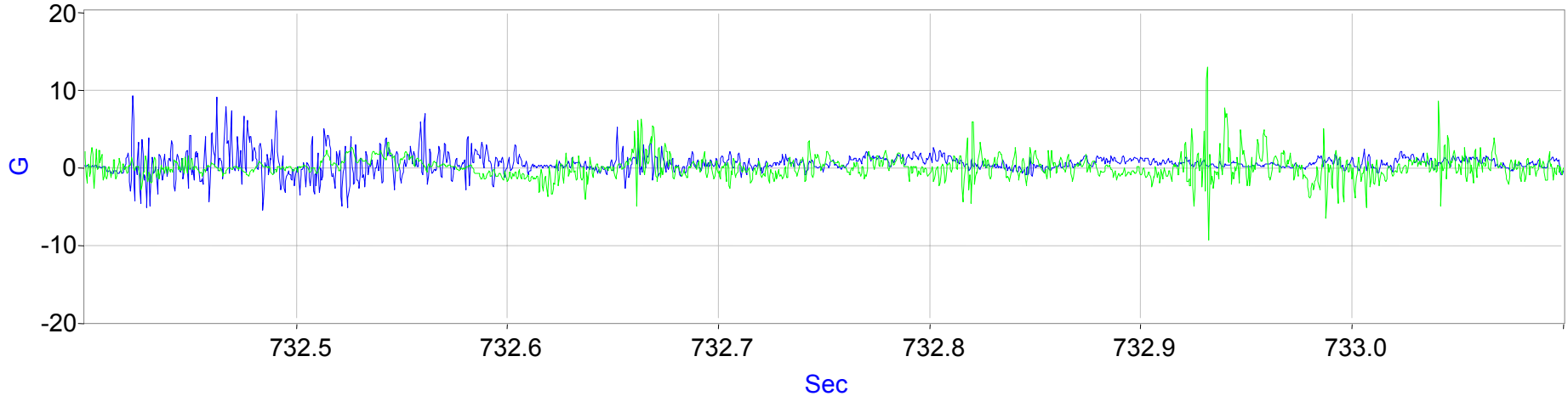

PSD of Center Caliper Vertical Accel, 16384 points, 5 point moving avg, t = 732 s,
blue = WABTEC/SAB-WABCO, green = Knorr

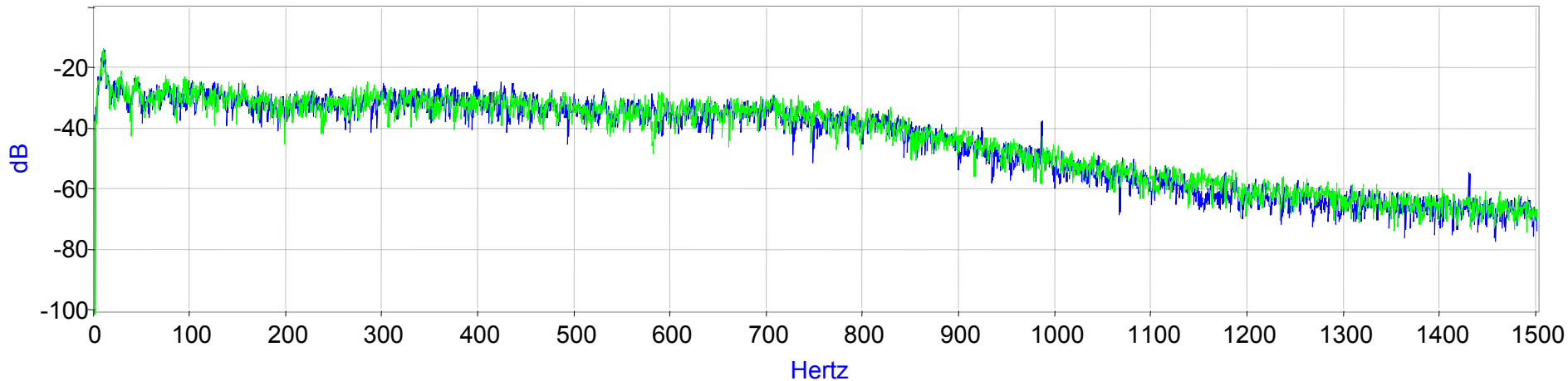

6/18/2005—File 30 (No Brake)

Center Caliper Longitudinal Accel, blue = WABTEC/SAB-WABCO, green = Knorr

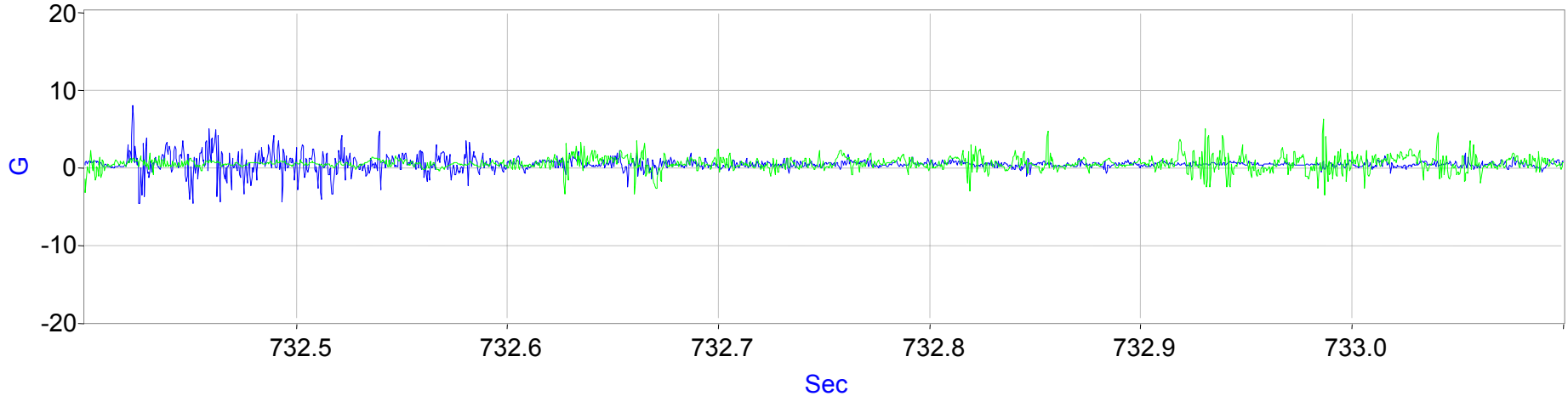

PSD of Center Caliper Longitudinal Accel, 16384 points, 5 point moving avg, t = 732s,
blue = WABTEC/SAB-WABCO, green = Knorr

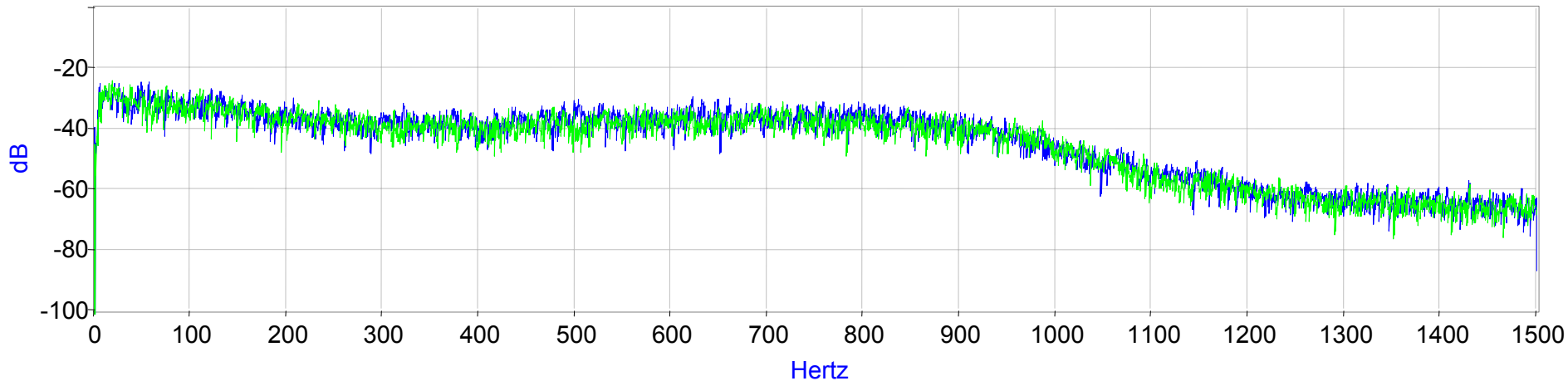

F-78

Brake Mount Accelerations

- June 18, 2005 File 24, t = 310—No BOP, Braking
- June 18, 2005 File 24, t = 581—BOP, Braking
- June 18, 2005 File 30, t = 732—BOP, Response to Impact

6/18/2005-File 24

Brake Mount Lateral Accel, blue = WABTEC/SAB-WABCO, green = Knorr

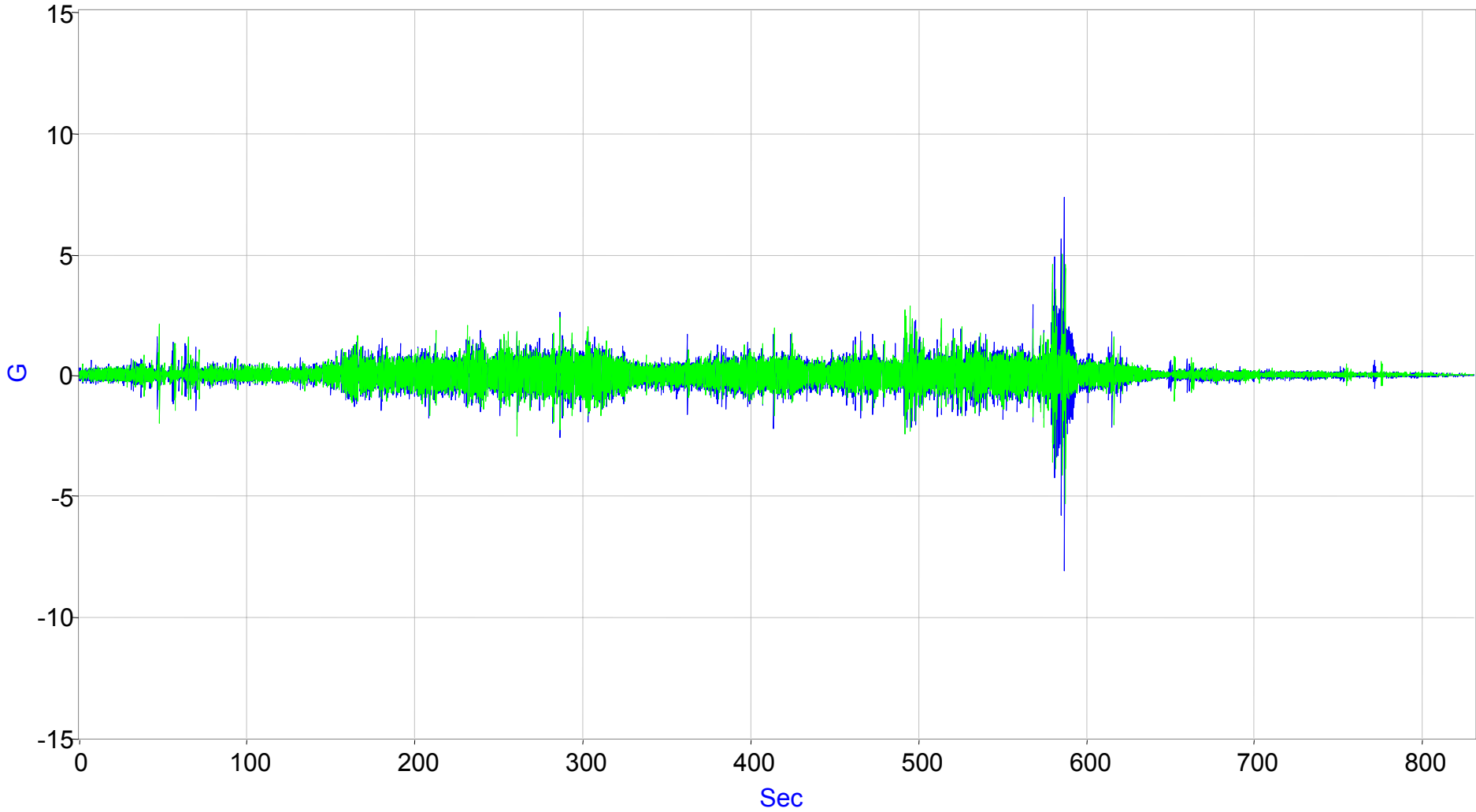

F-80

6/18/2005–File 24

Brake Mount Vertical Accel, blue = WABTEC/SAB-WABCO, green = Knorr

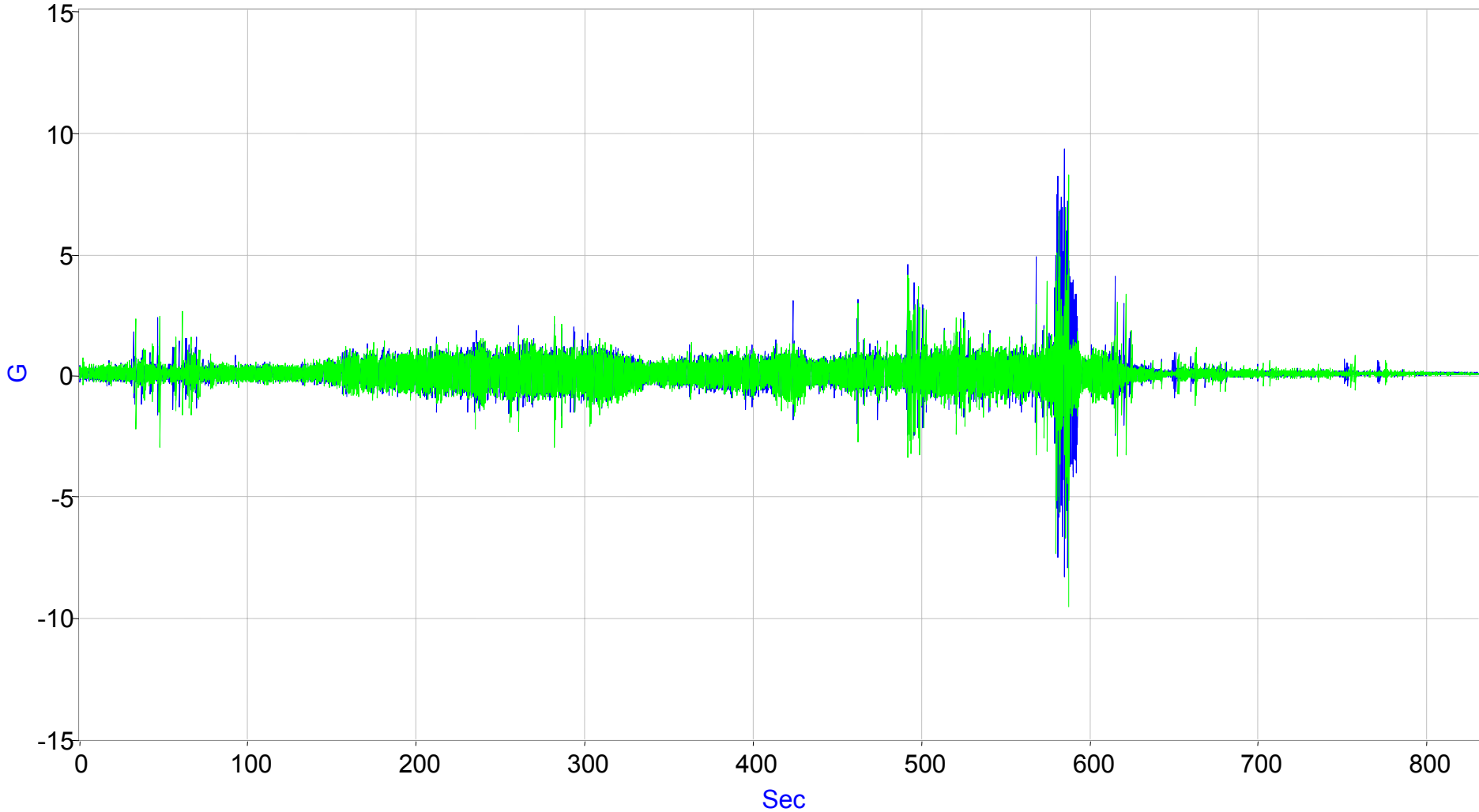

F-81

6/18/2005–File 24

Brake Mount Longitudinal Accel, blue = WABTEC/SAB-WABCO, green = Knorr

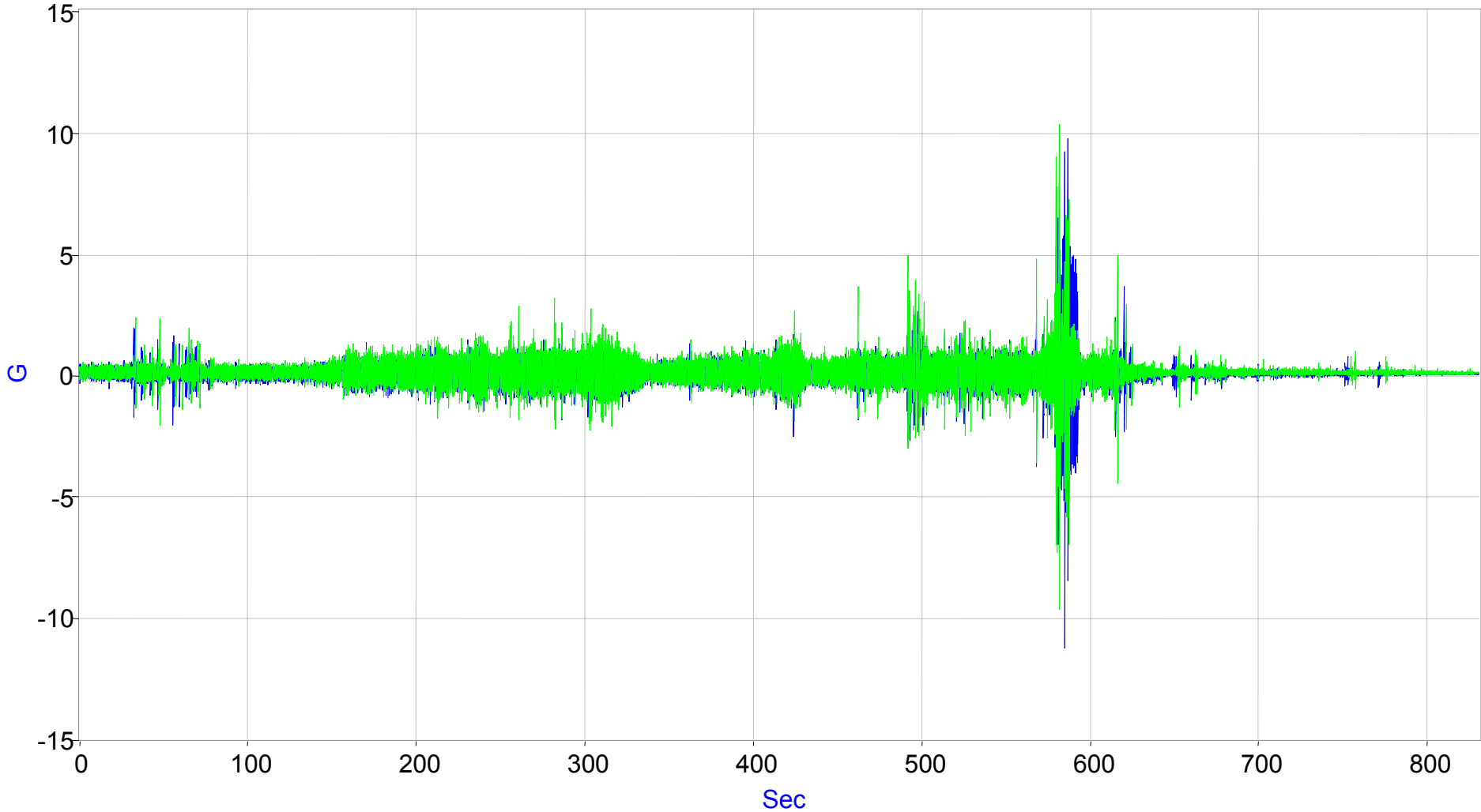

F-82

6/18/2005–File 24 (Brake, No SO)

Brake Mount Lateral Accel, blue = WABTEC/SAB-WABCO, green = Knorr

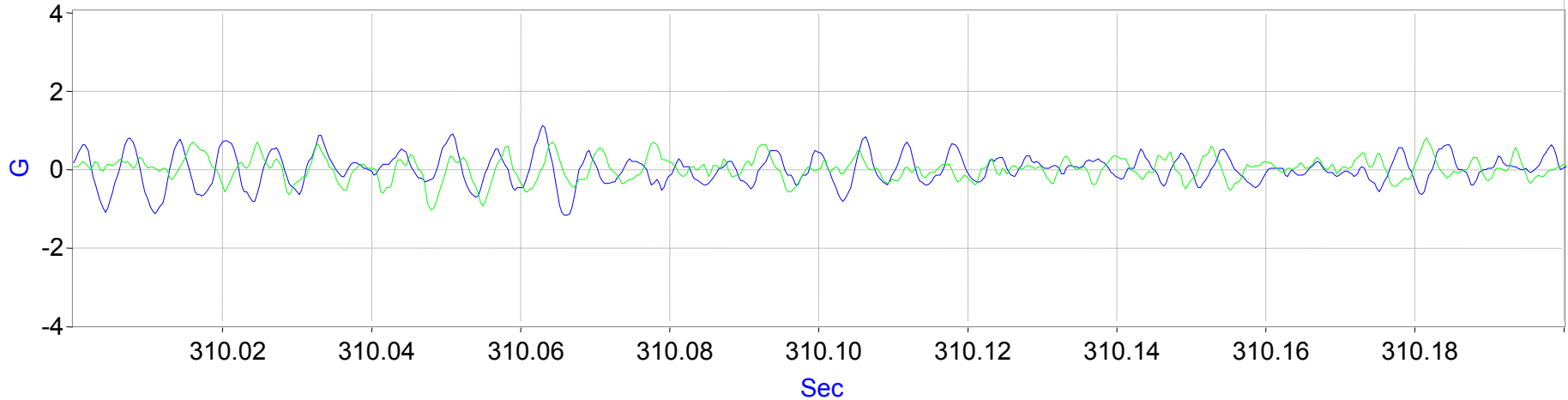

PSD of Brake Mount Lateral Accel, 16384 points, 5 point moving avg, t = 310 s,
blue = WABTEC/SAB-WABCO, green = Knorr

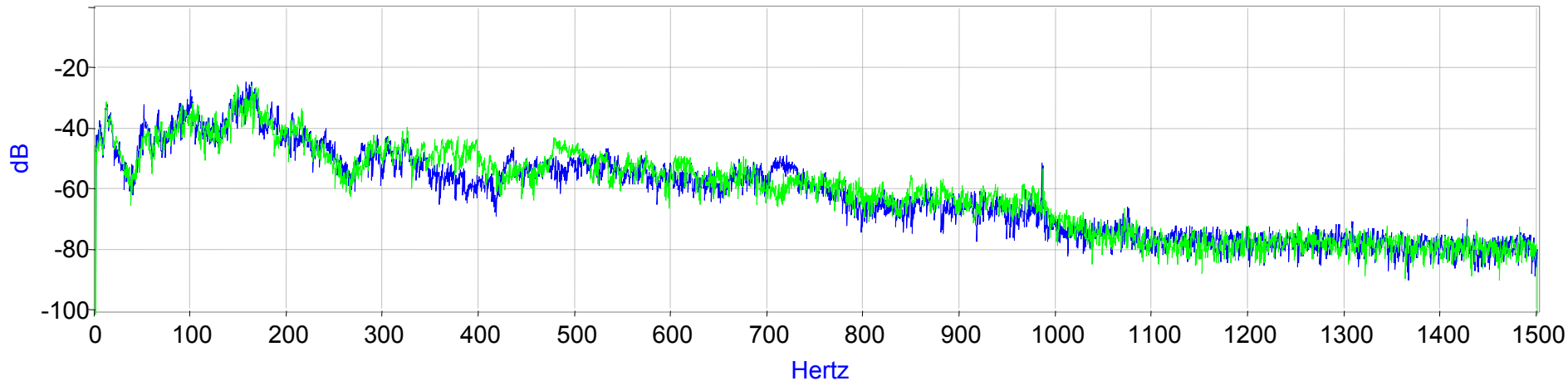

6/18/2005—File 24 (Brake, No SO)

Brake Mount Vertical Accel, blue = WABTEC/SAB-WABCO, green = Knorr

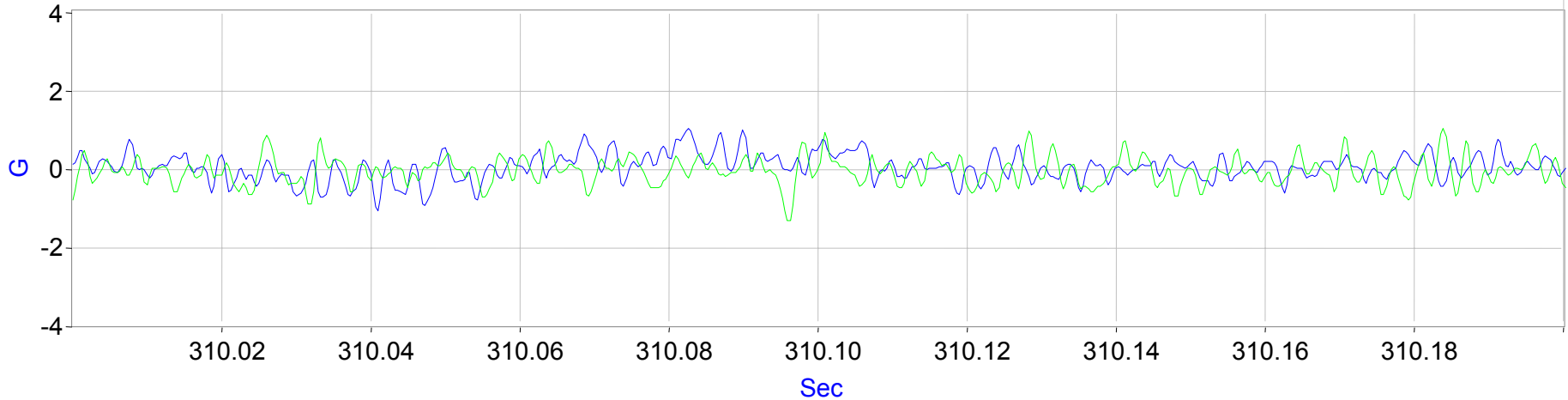

PSD of Brake Mount Vertical Accel, 16384 points, 5 point moving avg, t = 310 s,
blue = WABTEC/SAB-WABCO, green = Knorr

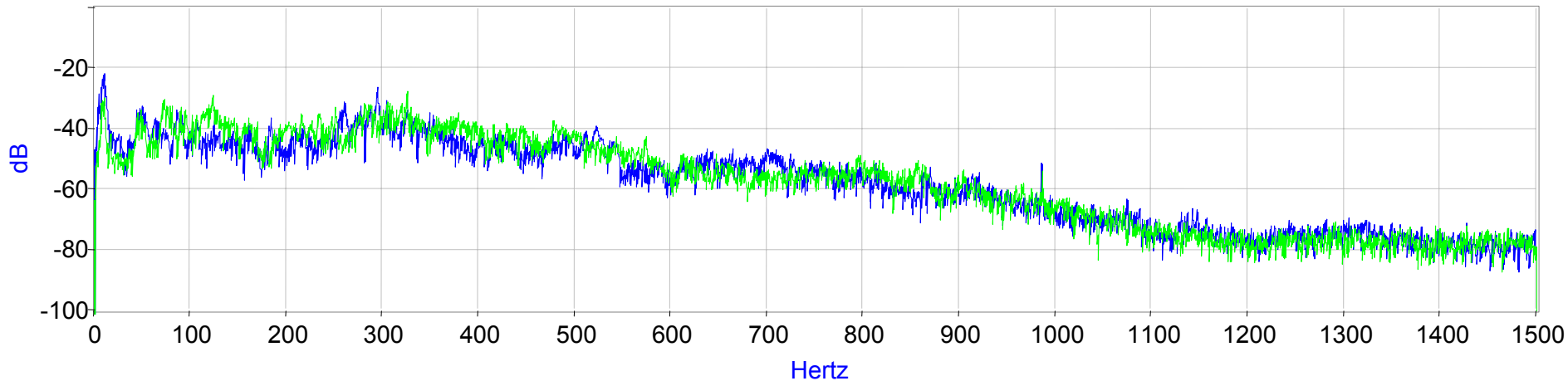

F-84

6/18/2005—File 24 (Brake, No SO)

Brake Mount Longitudinal Accel, blue = WABTEC/SAB-WABCO, green = Knorr

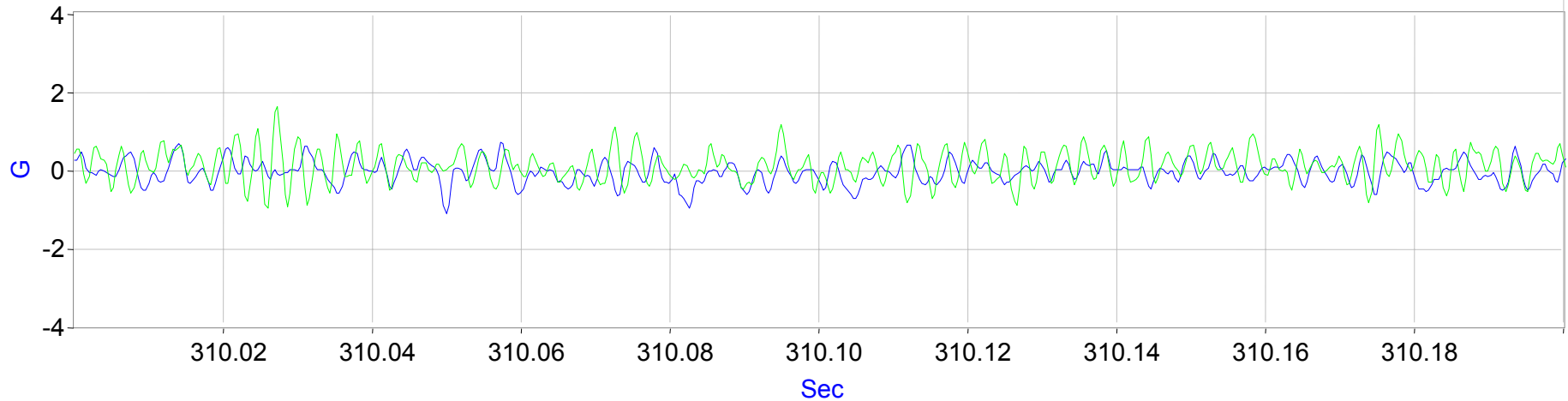

PSD of Brake Mount Longitudinal Accel, 16384 points, 5 point moving avg, t = 310 s,
blue = WABTEC/SAB-WABCO, green = Knorr

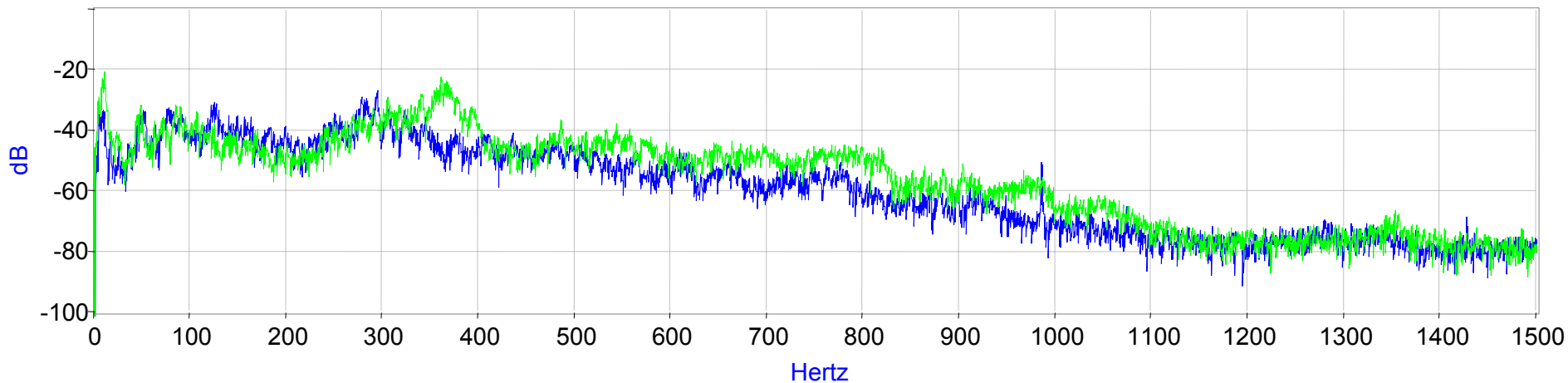

F-85

6/18/2005–File 24 (Brake, SO)

Brake Mount Lateral Accel, blue = WABTEC/SAB-WABCO, green = Knorr

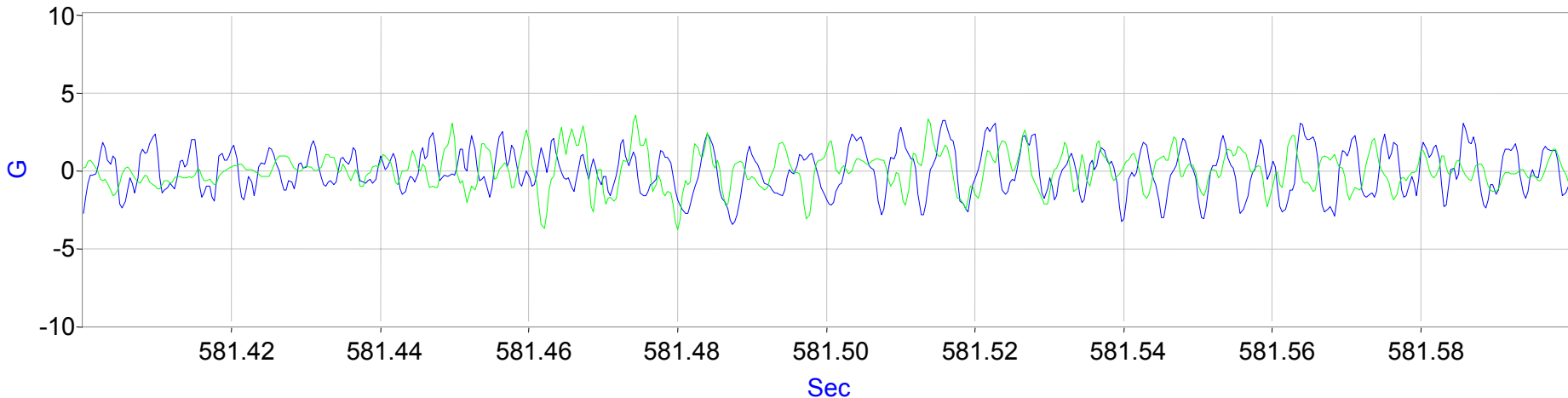

PSD of Brake Mount Lateral Accel, 16384 points, 5 point moving avg, t = 581 s,
blue = WABTEC/SAB-WABCO, green = Knorr

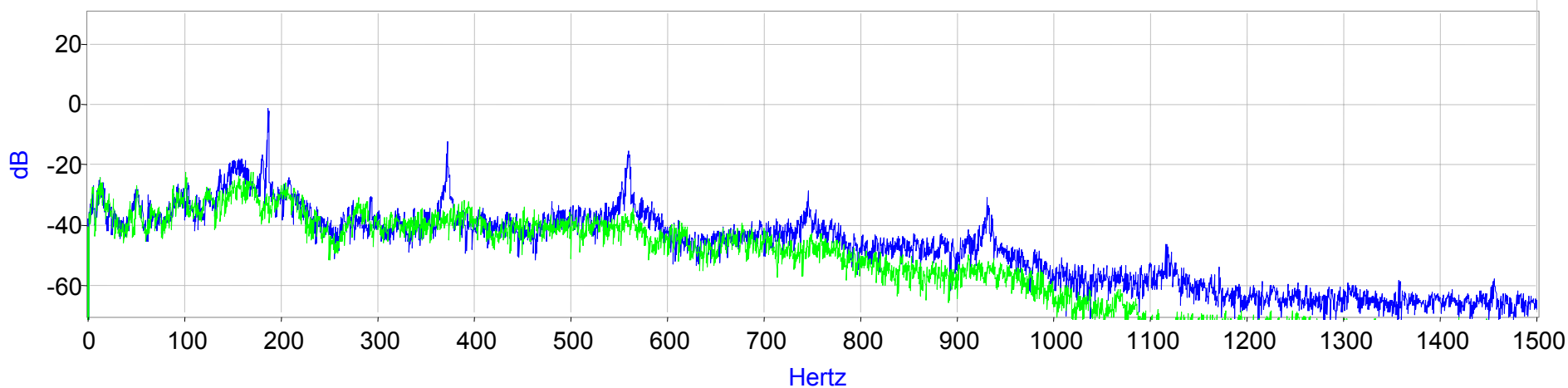

F-86

6/18/2005–File 24 (Brake, SO)

Brake Mount Vertical Accel, blue = WABTEC/SAB-WABCO, green = Knorr

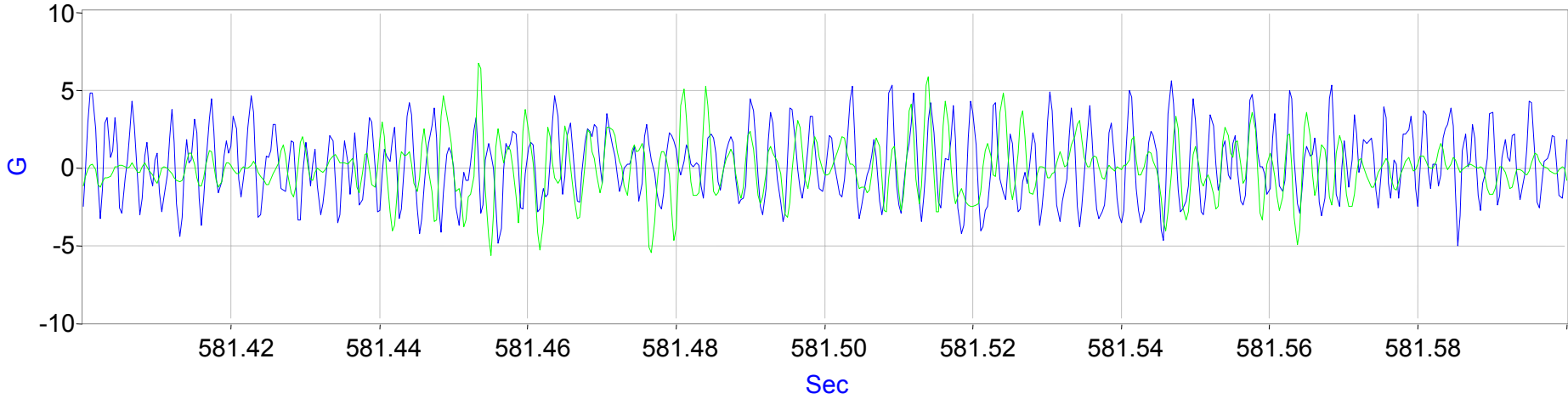

PSD of Brake Mount Vertical Accel, 16384 points, 5 point moving avg, t = 581 s,
blue = WABTEC/SAB-WABCO, green = Knorr

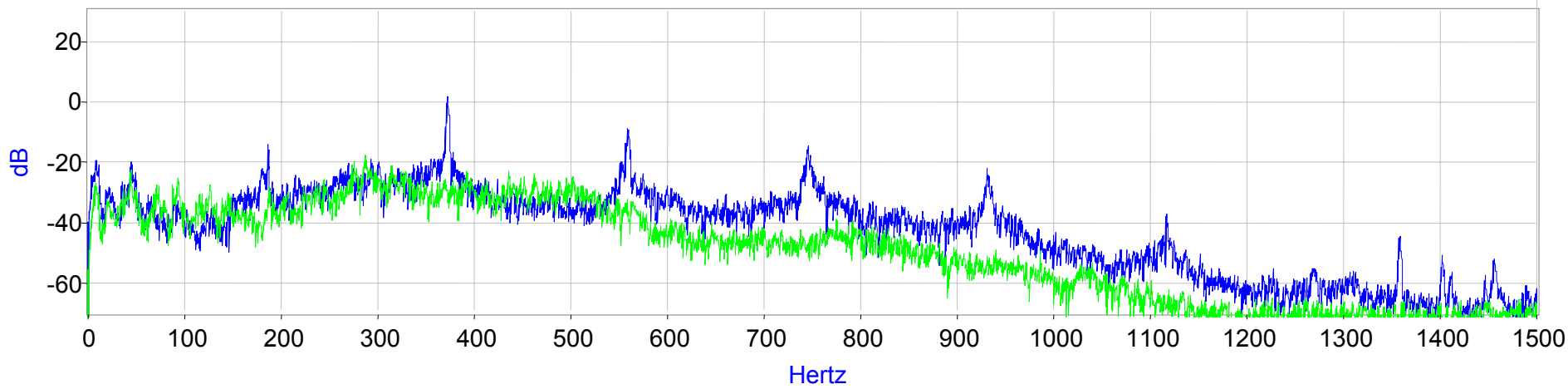

6/18/2005–File 24 (Brake, SO)

Brake Mount Longitudinal Accel, blue = WABTEC/SAB-WABCO, green = Knorr

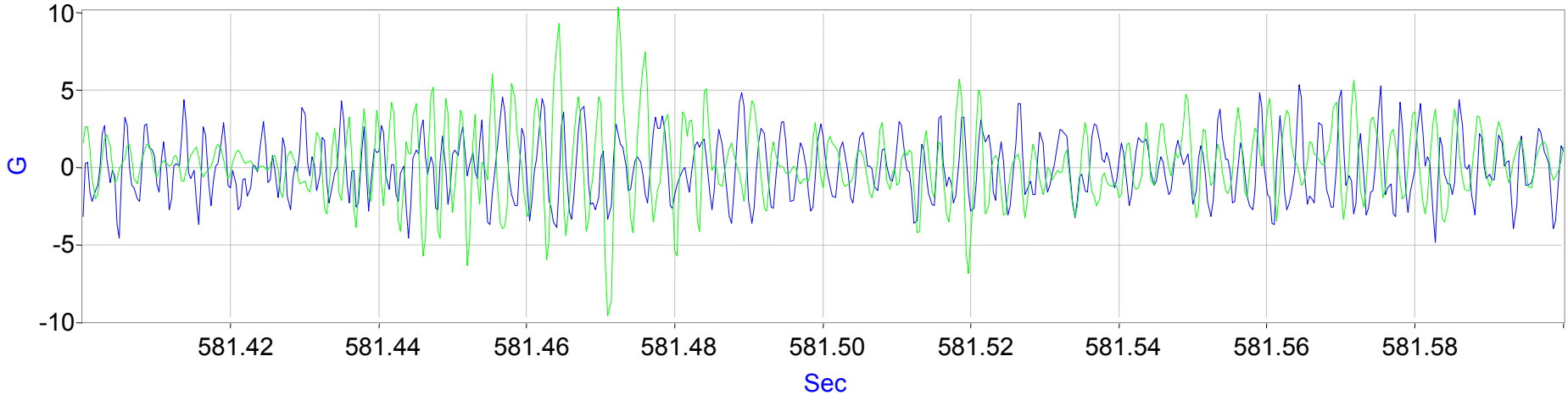

PSD of Brake Mount Longitudinal Accel, 16384 points, 5 point moving avg, t = 581 s,
blue = WABTEC/SAB-WABCO, green = Knorr

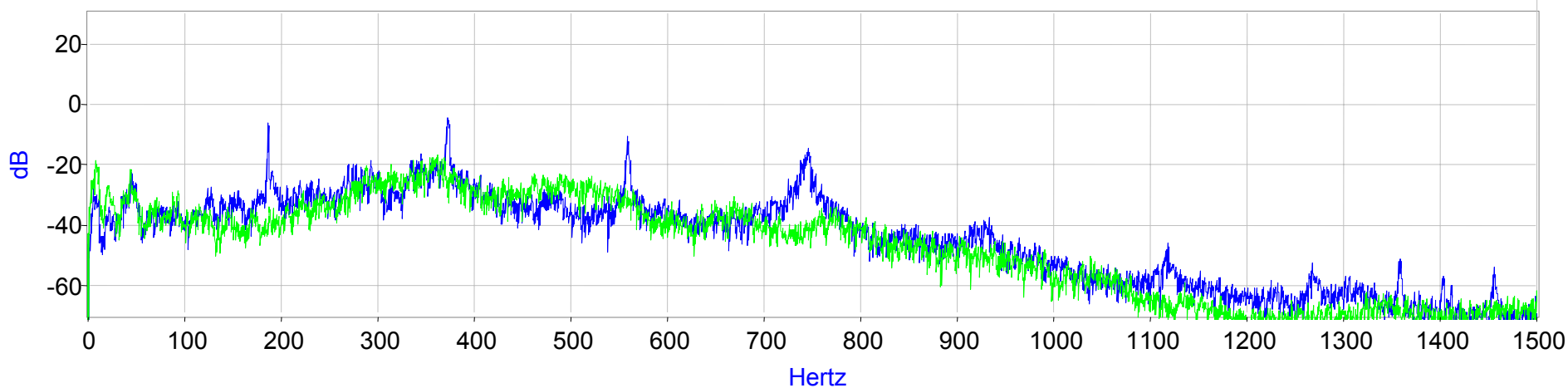

F-88

6/18/2005–File 30 (No Brake)

Brake Mount Lateral Accel, blue = WABTEC/SAB-WABCO, green = Knorr

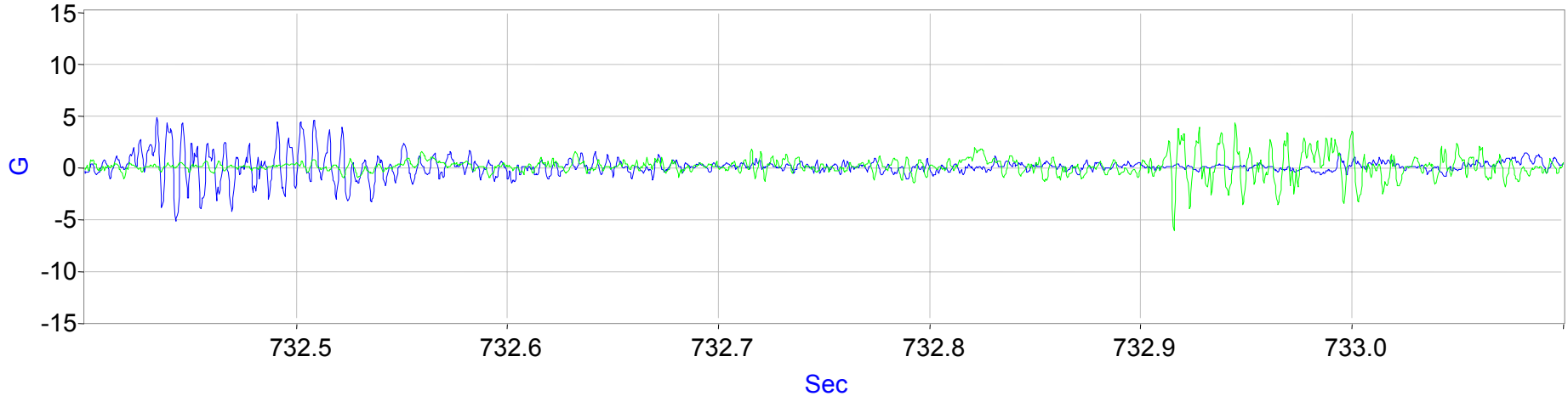

PSD of Brake Mount Lateral Accel, 16384 points, 5 point moving avg, t = 732 s,
blue = WABTEC/SAB-WABCO, green = Knorr

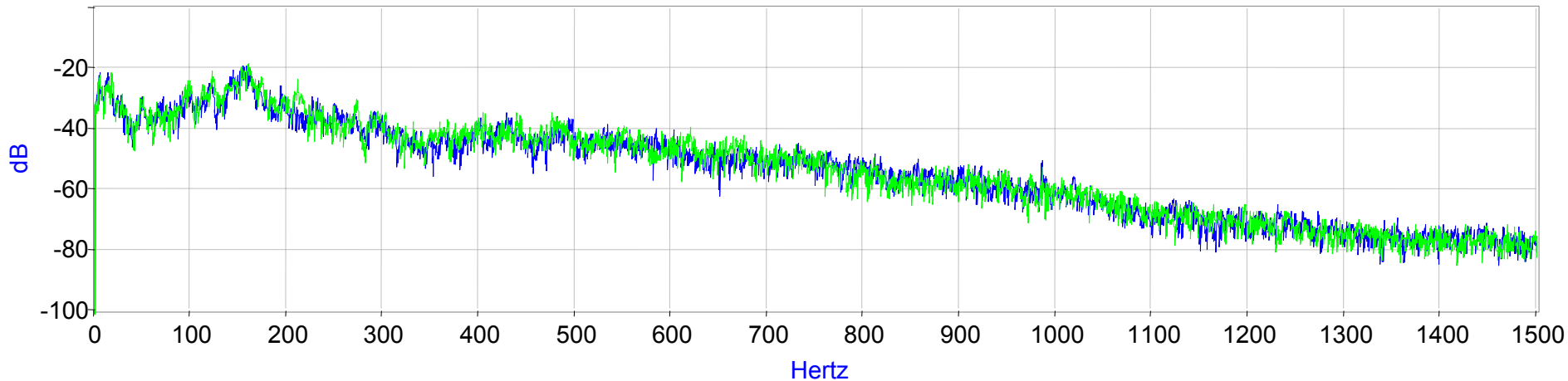

F-89

6/18/2005—File 30 (No Brake)

Brake Mount Vertical Accel, blue = WABTEC/SAB-WABCO, green = Knorr

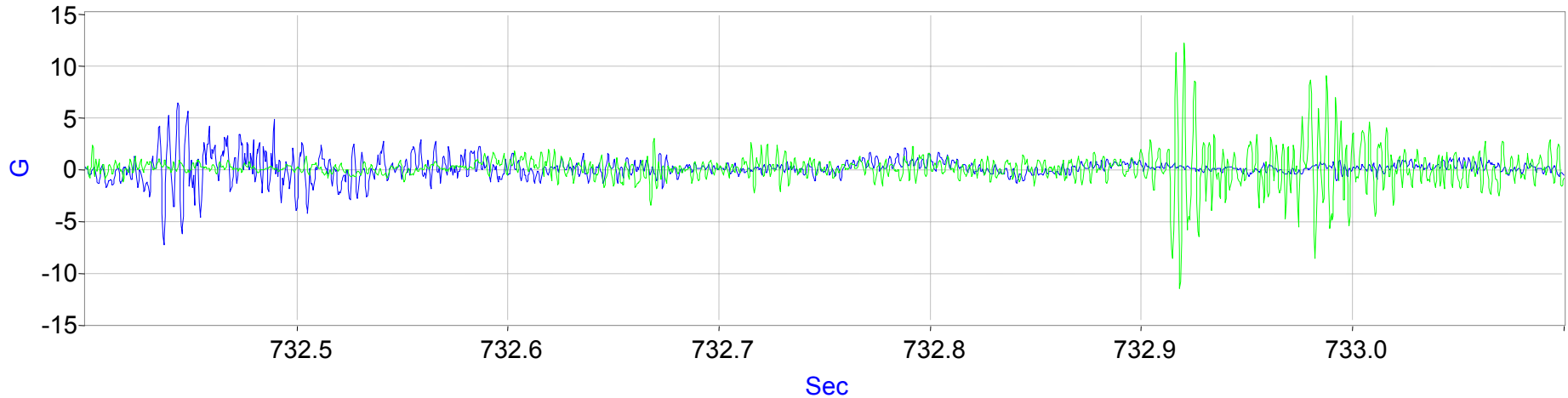

PSD of Brake Mount Vertical Accel, 16384 points, 5 point moving avg, t = 732 s,
blue = WABTEC/SAB-WABCO, green = Knorr

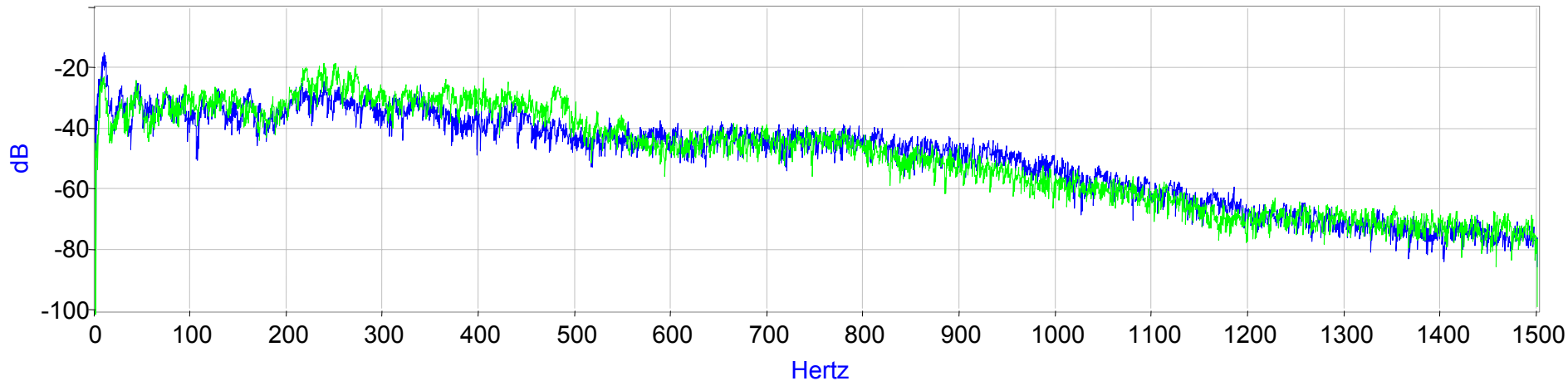

6/18/2005—File 30 (No Brake)

Brake Mount Longitudinal Accel, blue = WABTEC/SAB-WABCO, green = Knorr

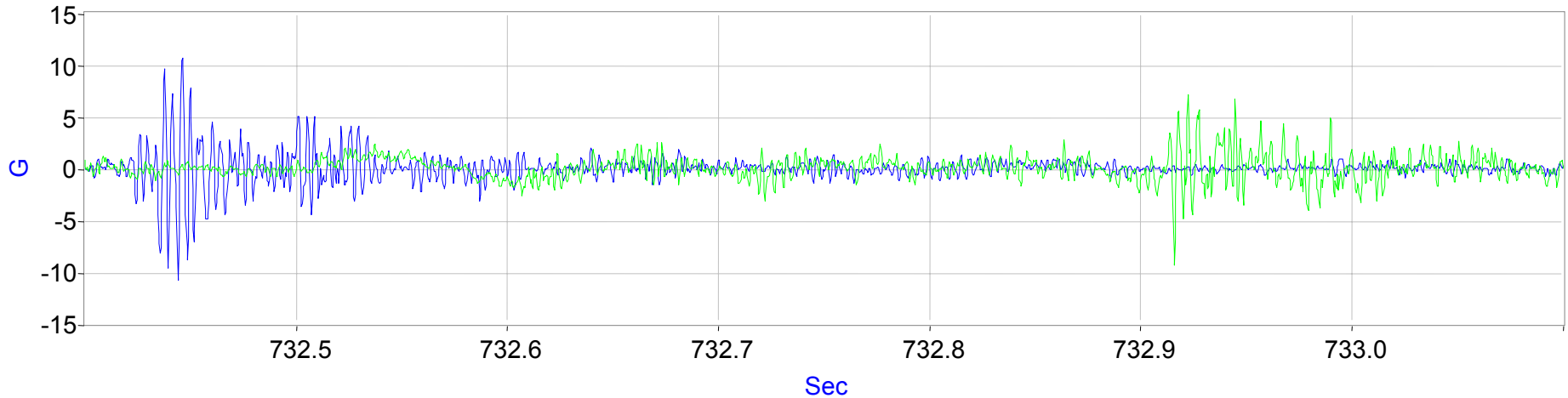

PSD of Brake Mount Longitudinal Accel, 16384 points, 5 point moving avg, t = 732 s,
blue = WABTEC/SAB-WABCO, green = Knorr

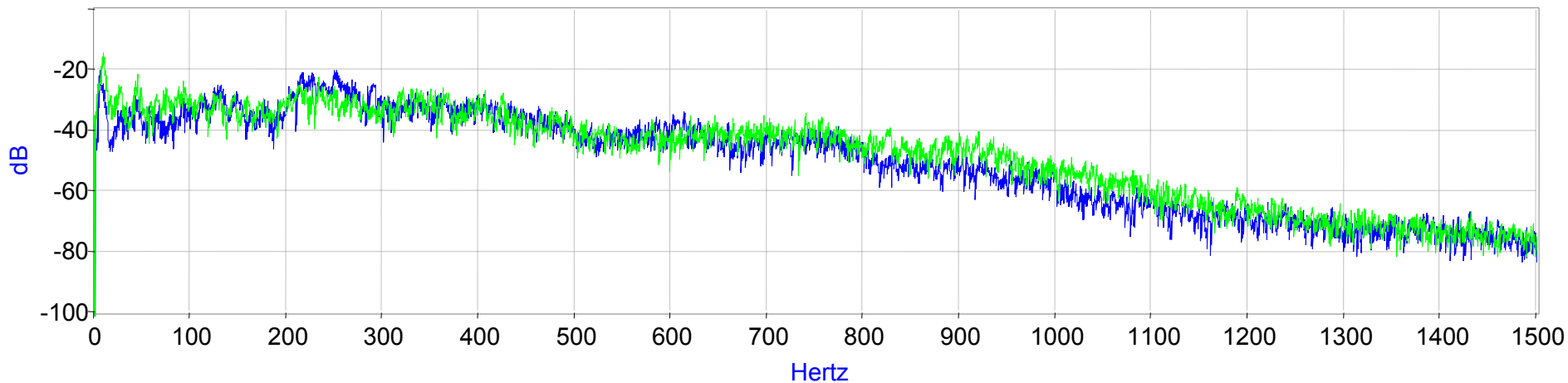

Truck Accelerations

- June 18, 2005 File 24, t = 310–No BOP, Braking
- June 18, 2005 File 24, t = 581–BOP, Braking
- June 18, 2005 File 30, t = 732–BOP, Response to Impact

6/18/2005–File 24

Truck Lateral Accel, blue = WABTEC/SAB-WABCO, green = Knorr

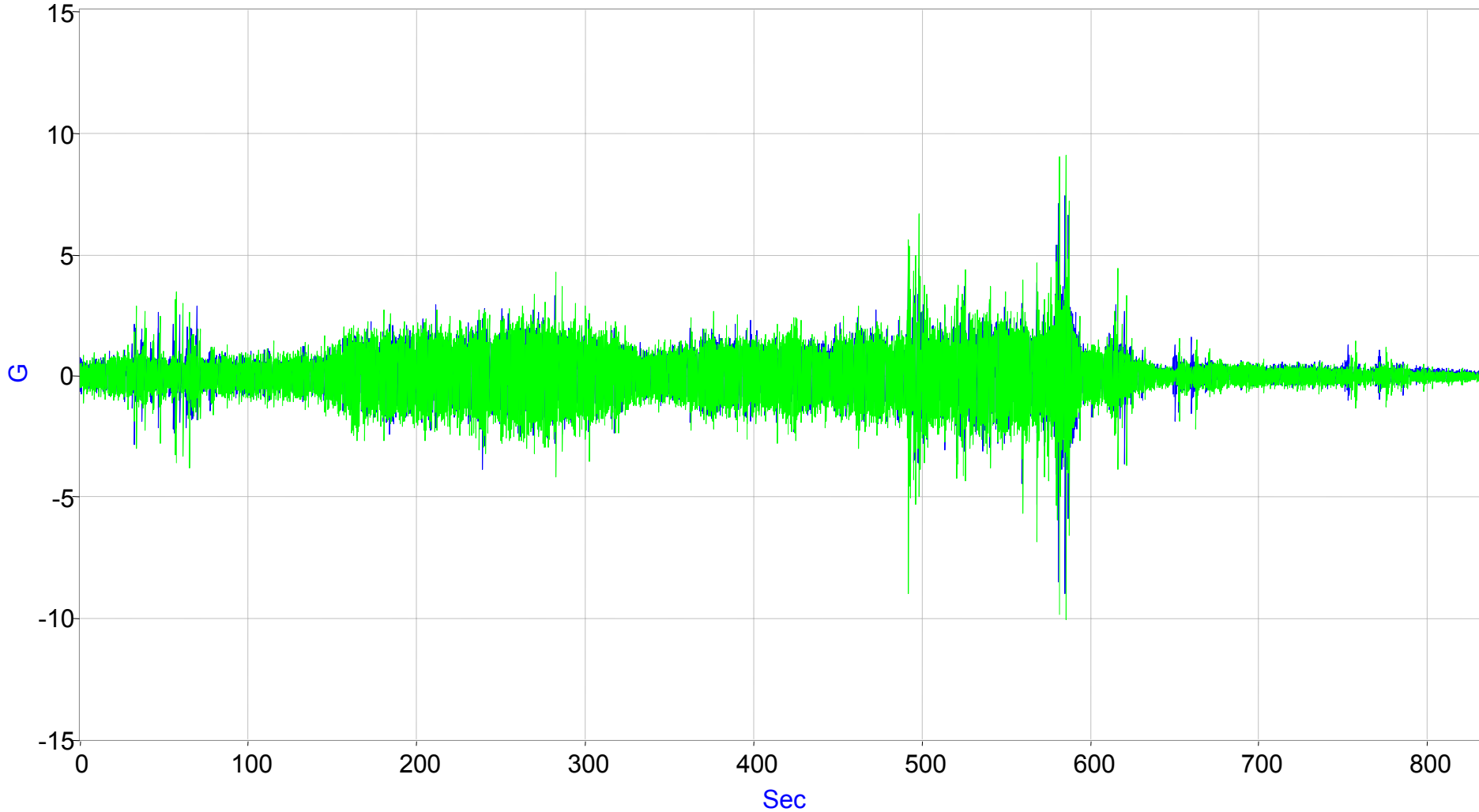

F-93

6/18/2005-File 24

Truck Vertical Accel, blue = WABTEC/SAB-WABCO, green = Knorr

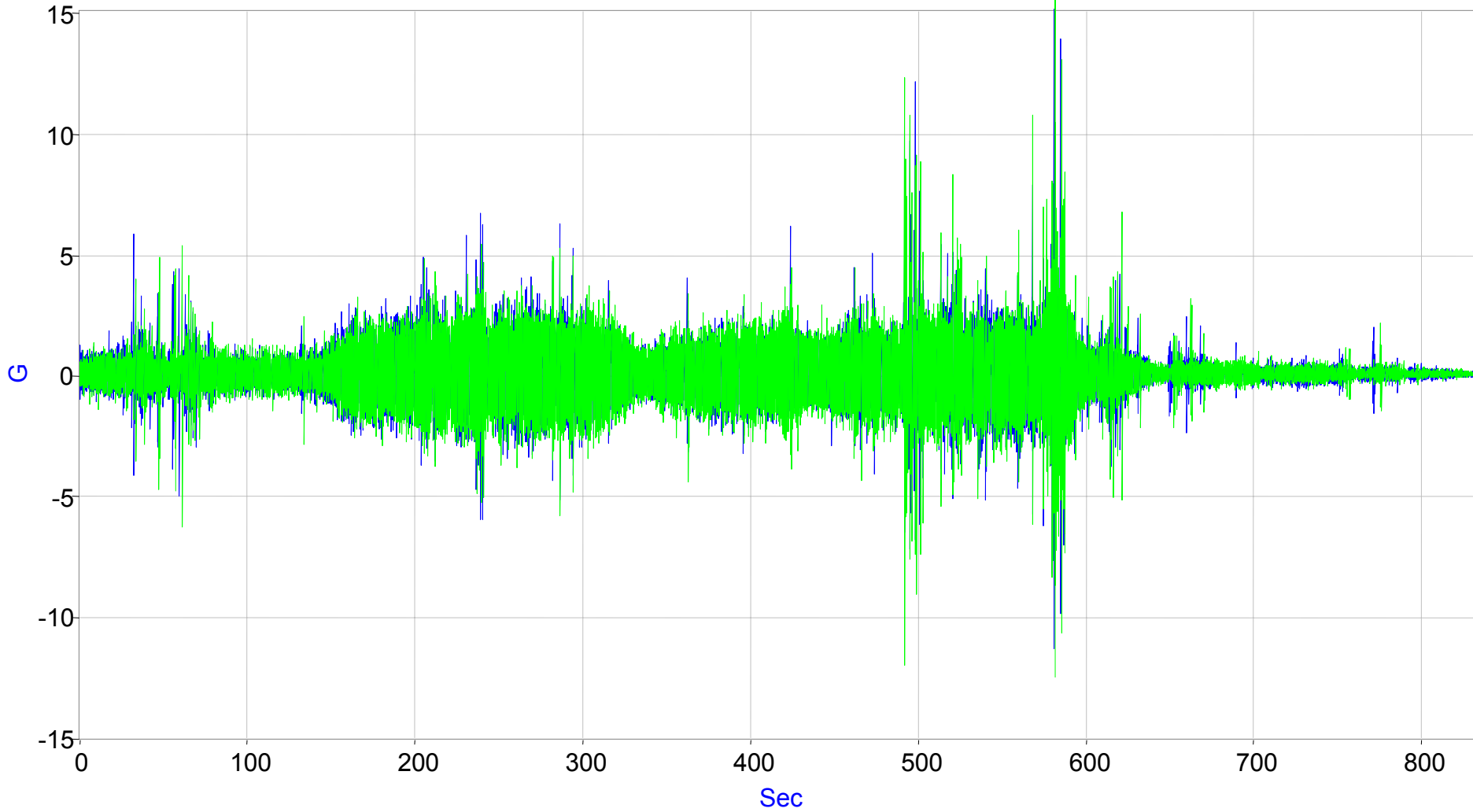

F-94

6/18/2005–File 24

Truck Longitudinal Accel, blue = WABTEC/SAB-WABCO, green = Knorr

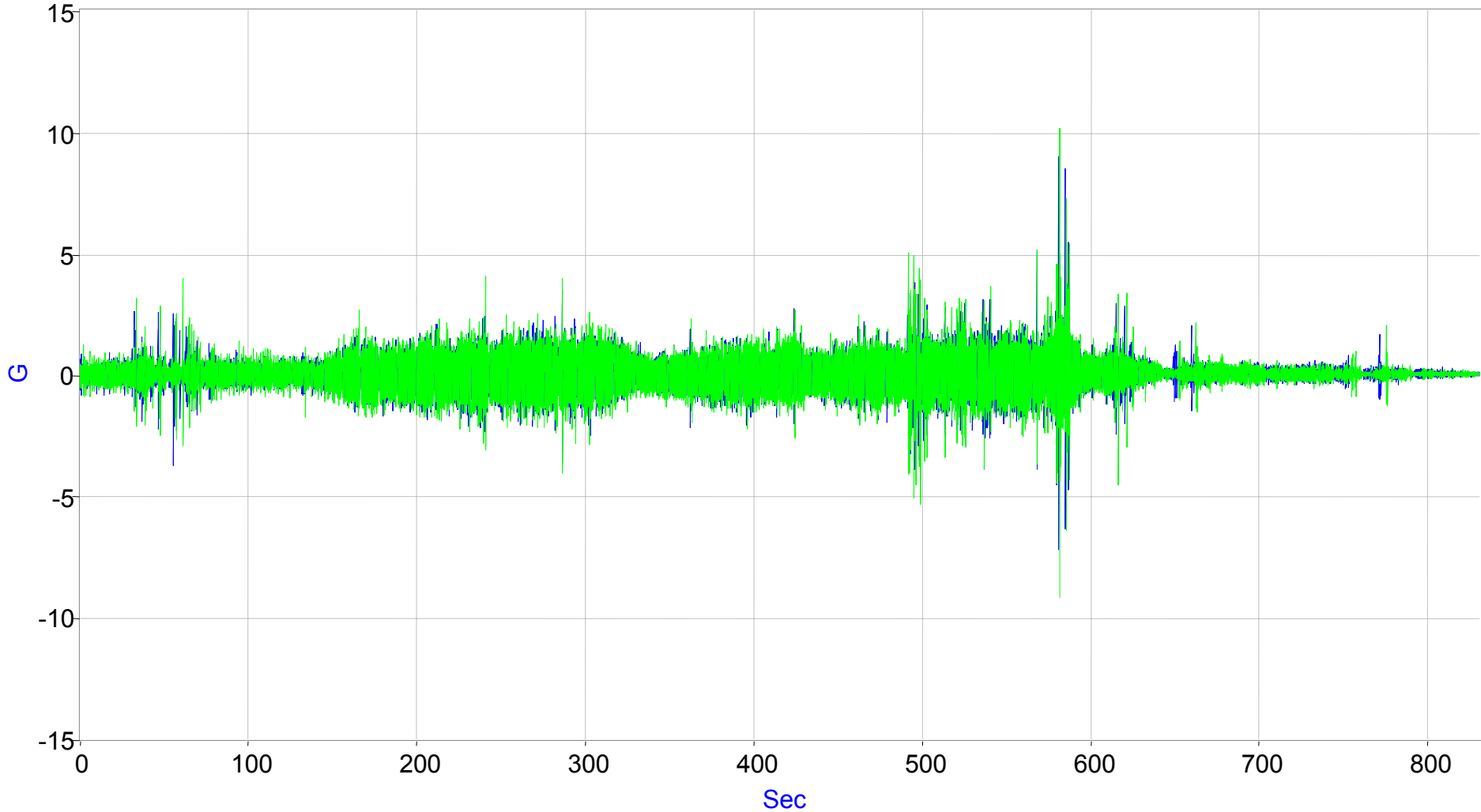

F-95

6/18/2005—File 24 (Brake, No SO)

Truck Lateral Accel, blue = WABTEC/SAB-WABCO, green = Knorr

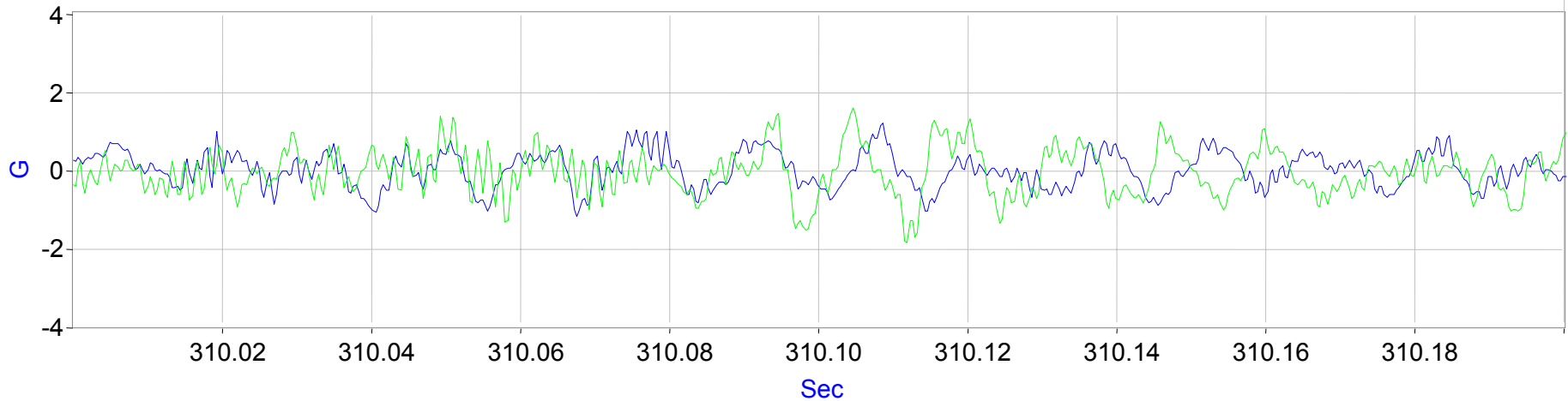

PSD of Truck Lateral Accel, 16384 points, 5 point moving avg, t = 310 s,
blue = WABTEC/SAB-WABCO, green = Knorr

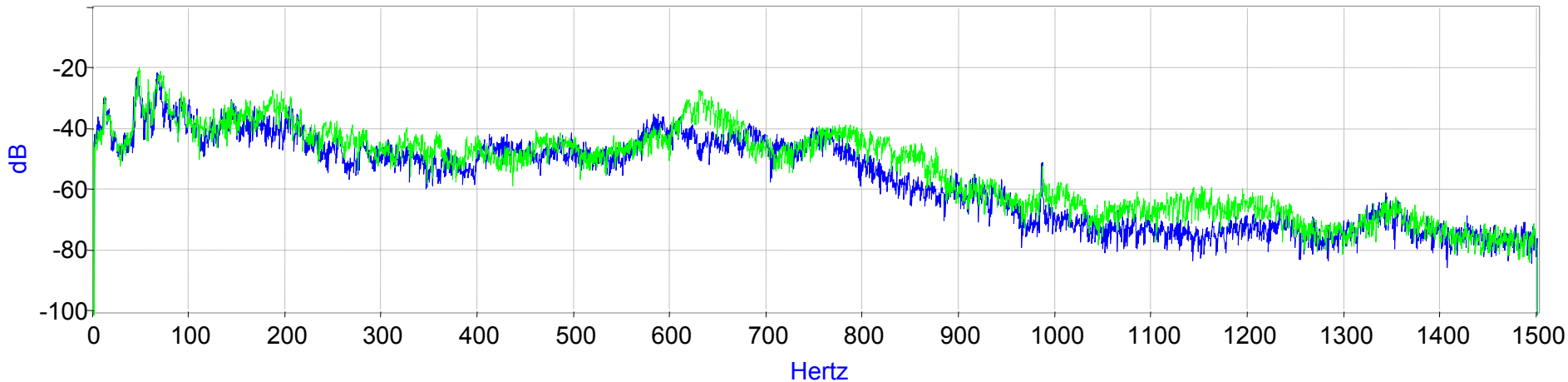

F-96

6/18/2005—File 24 (Brake, No SO)

Truck Vertical Accel, blue = WABTEC/SAB-WABCO, green = Knorr

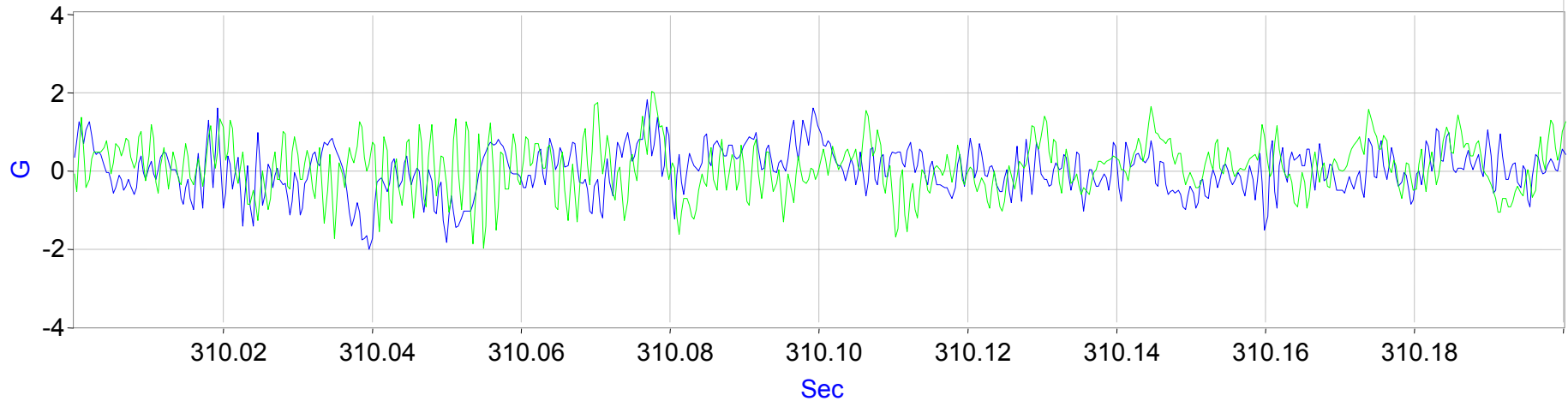

PSD of Truck Vertical Accel, 16384 points, 5 point moving avg, t = 310 s,
blue = WABTEC/SAB-WABCO, green = Knorr

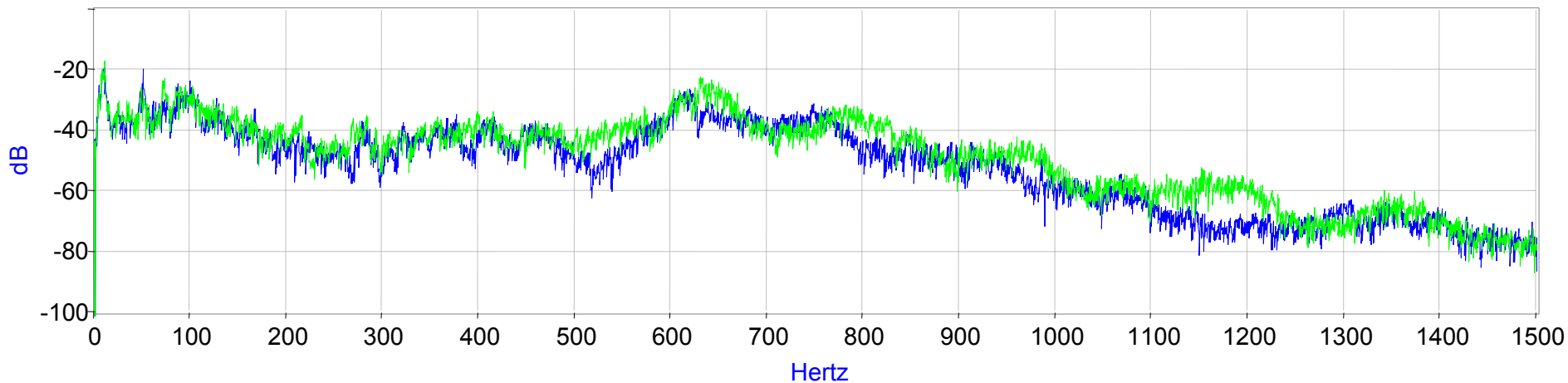

6/18/2005–File 24 (Brake, No SO)

Truck Longitudinal Accel, blue = WABTEC/SAB-WABCO, green = Knorr

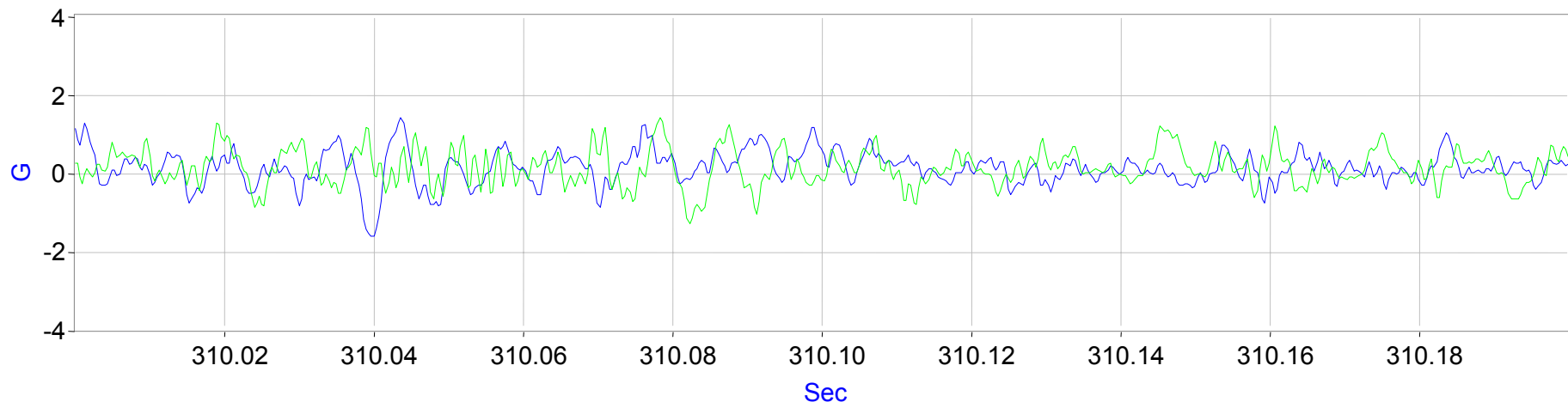

PSD of Truck Longitudinal Accel, 16384 points, 5 point moving avg, t = 310 s,
blue = WABTEC/SAB-WABCO, green = Knorr

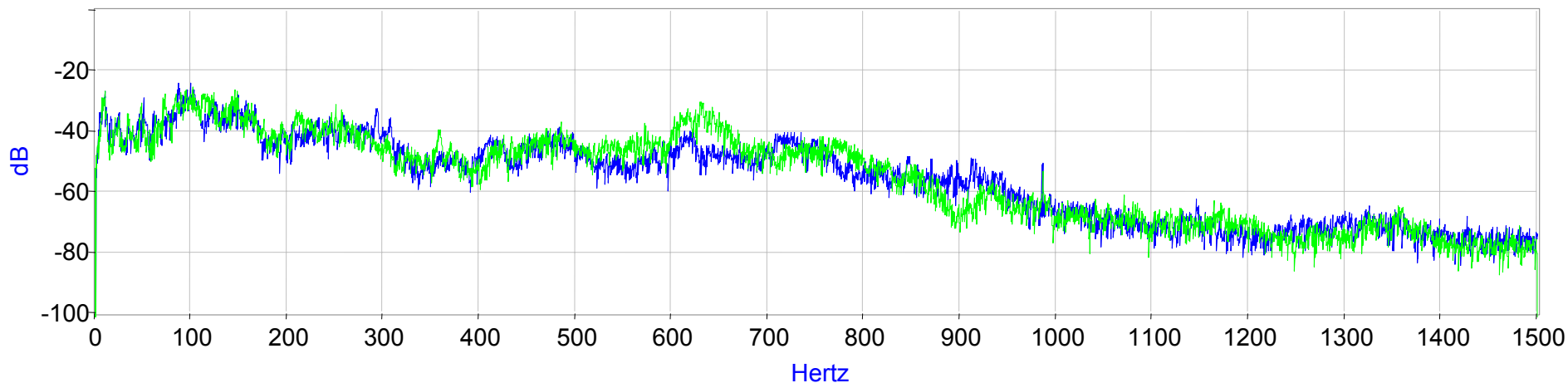

6/18/2005–File 24 (Brake, SO)

Truck Lateral Accel, blue = WABTEC/SAB-WABCO, green = Knorr

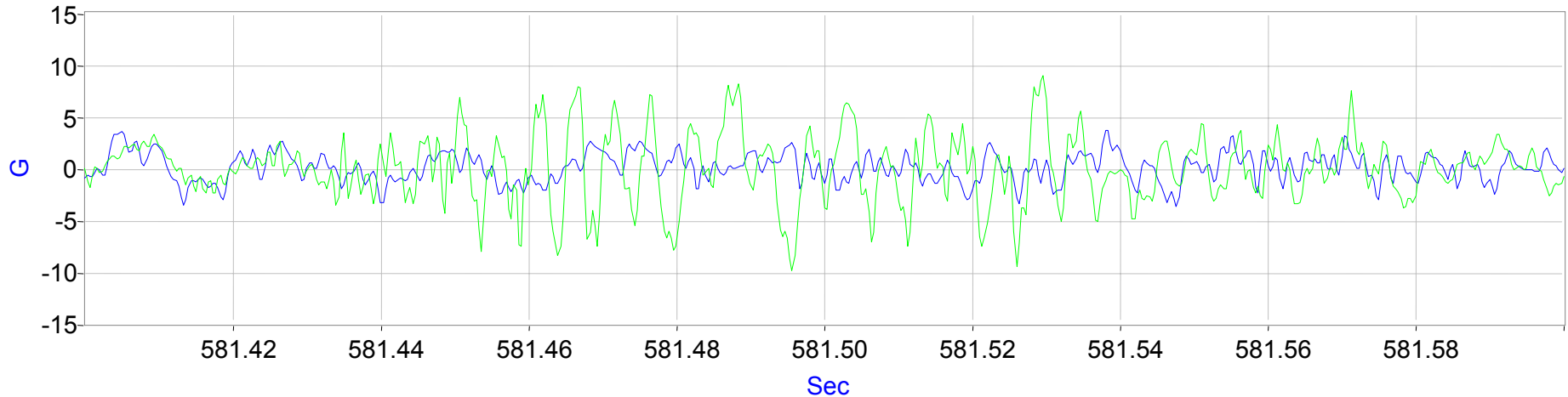

PSD of Truck Lateral Accel, 16384 points, 5 point moving avg, t = 581 s,
blue = WABTEC/SAB-WABCO, green = Knorr

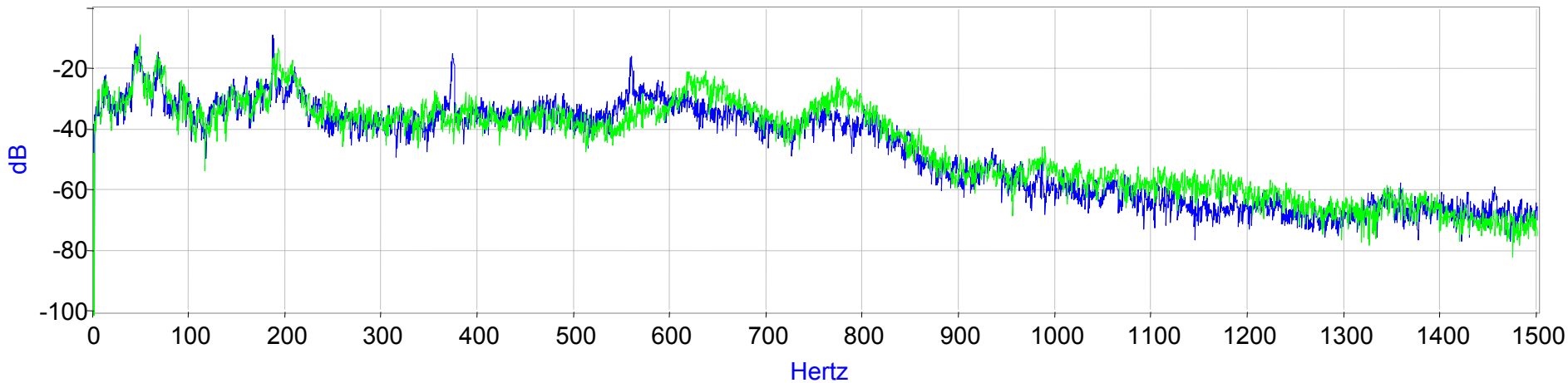

6/18/2005–File 24 (Brake, SO)

Truck Vertical Accel, blue = WABTEC/SAB-WABCO, green = Knorr

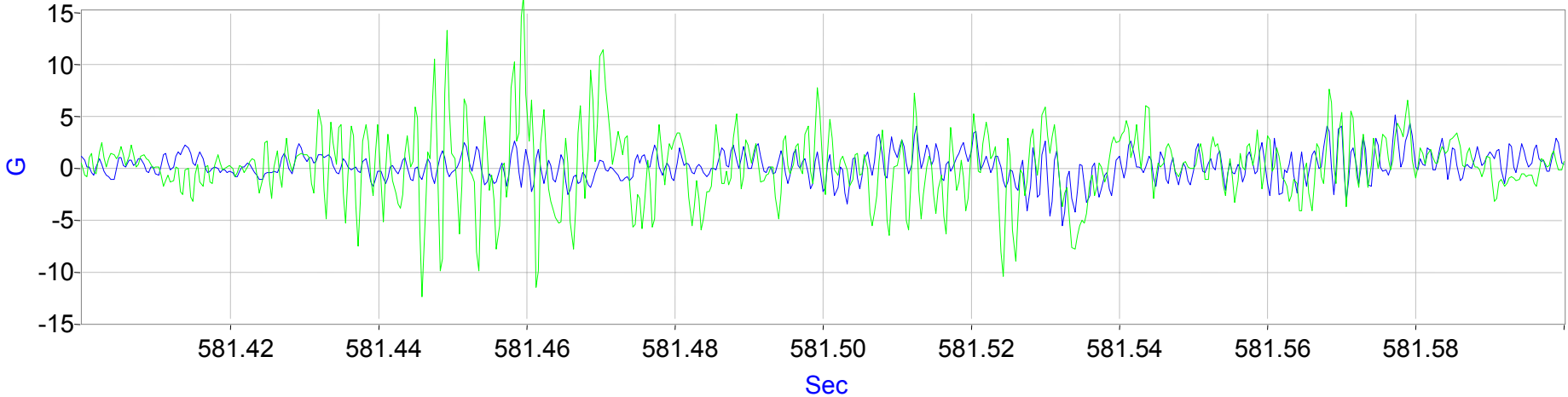

PSD of Truck Vertical Accel, 16384 points, 5 point moving avg, t = 581 s,
blue = WABTEC/SAB-WABCO, green = Knorr

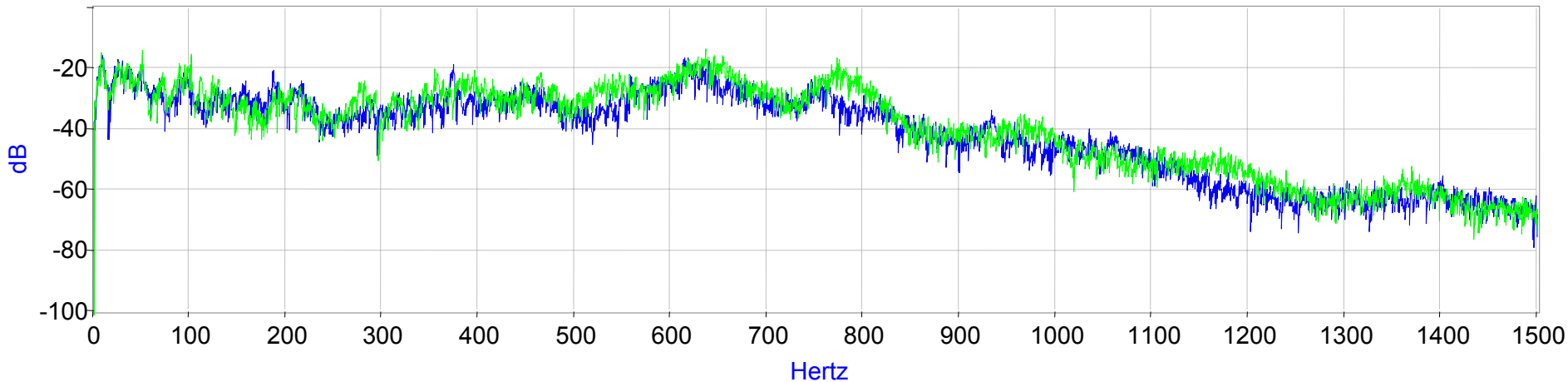

F-100

6/18/2005–File 24 (Brake, SO)

Truck Longitudinal Accel, blue = WABTEC/SAB-WABCO, green = Knorr

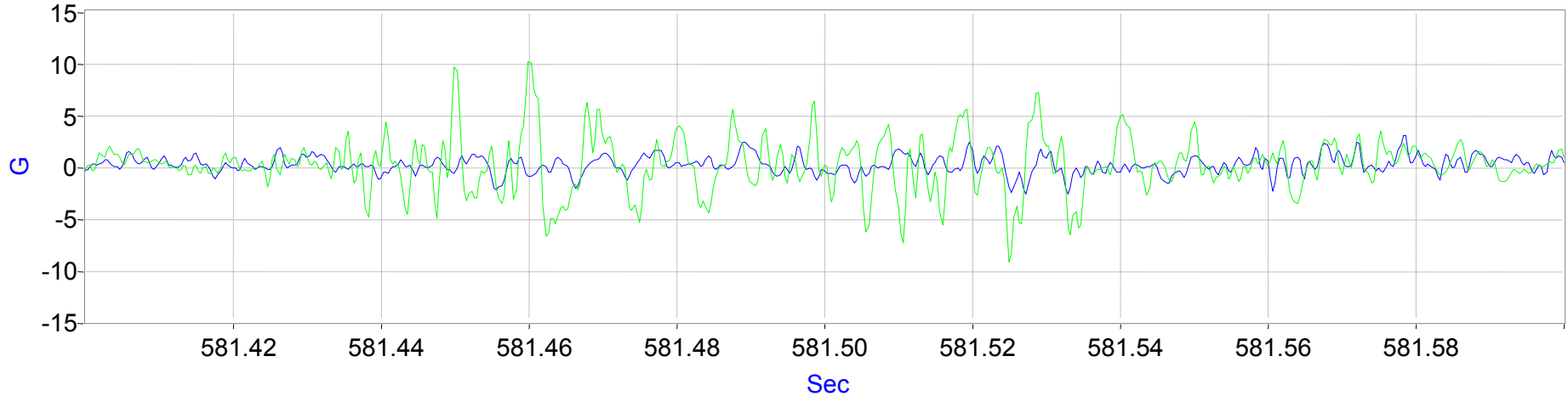

PSD of Truck Longitudinal Accel, 16384 points, 5 point moving avg, t = 581 s,
blue = WABTEC/SAB-WABCO, green = Knorr

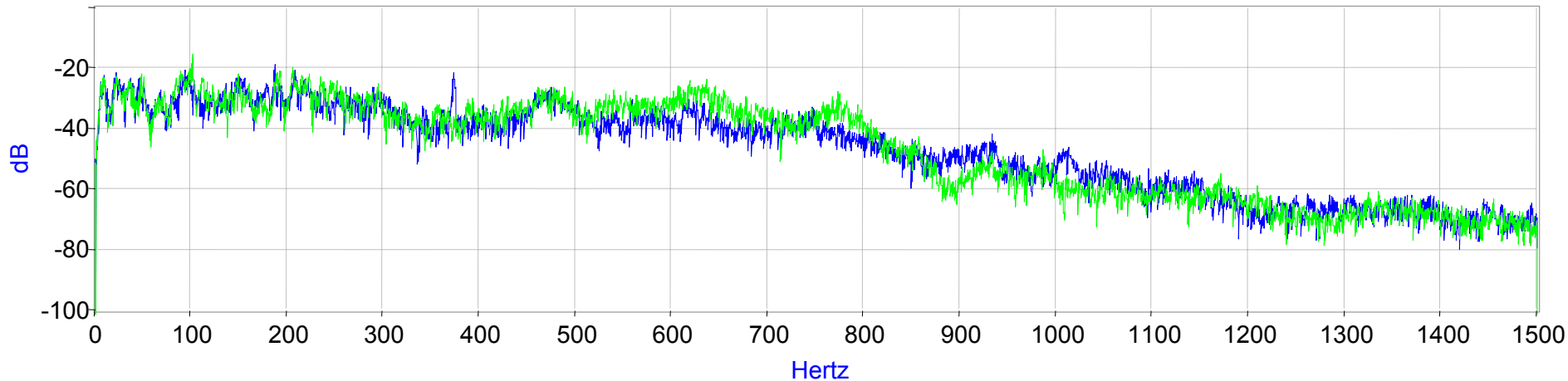

6/18/2005—File 30 (No Brake)

Truck Lateral Accel, blue = WABTEC/SAB-WABCO, green = Knorr

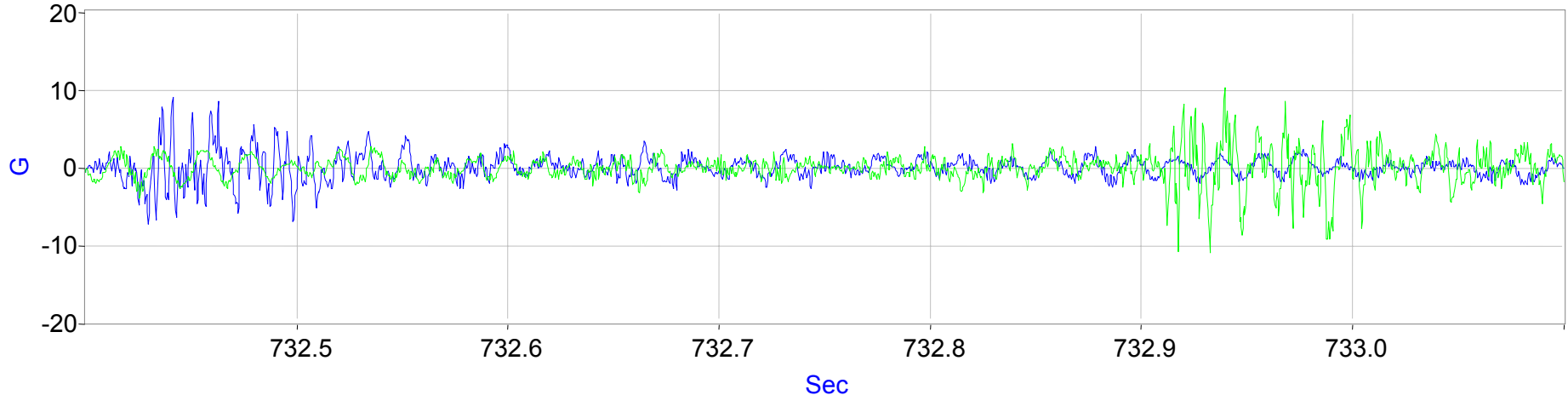

PSD of Truck Lateral Accel, 16384 points, 5 point moving avg, t = 732 s,
blue = WABTEC/SAB-WABCO, green = Knorr

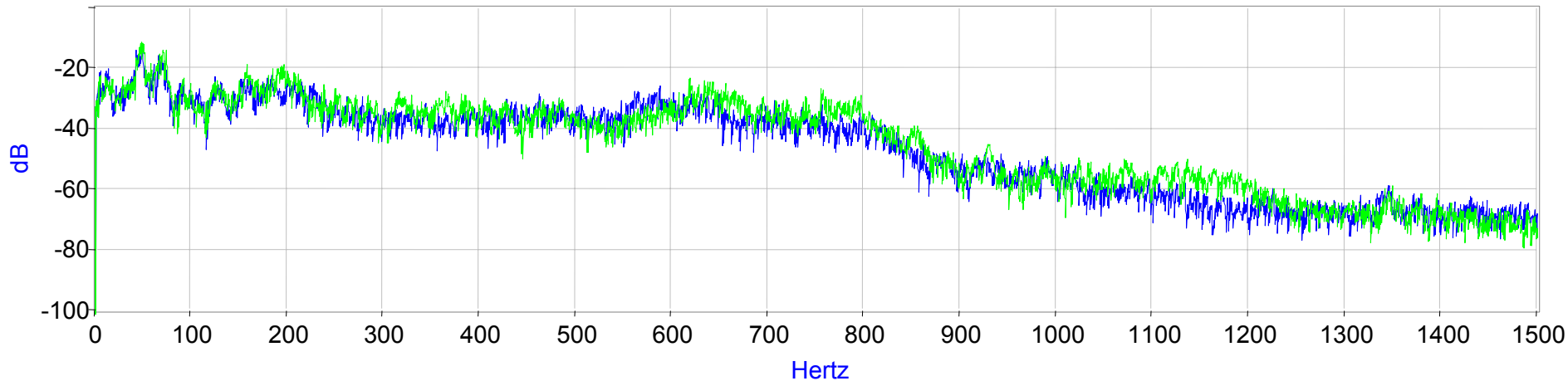

6/18/2005—File 30 (No Brake)

Truck Vertical Accel, blue = WABTEC/SAB-WABCO, green = Knorr

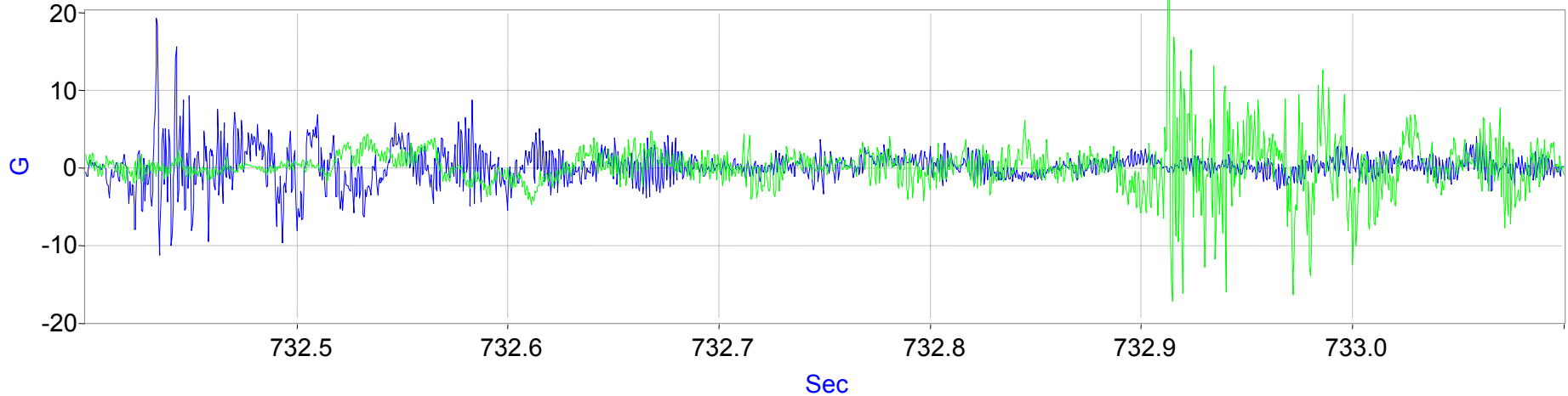

PSD of Truck Vertical Accel, 16384 points, 5 point moving avg, t = 732 s,
blue = WABTEC/SAB-WABCO, green = Knorr

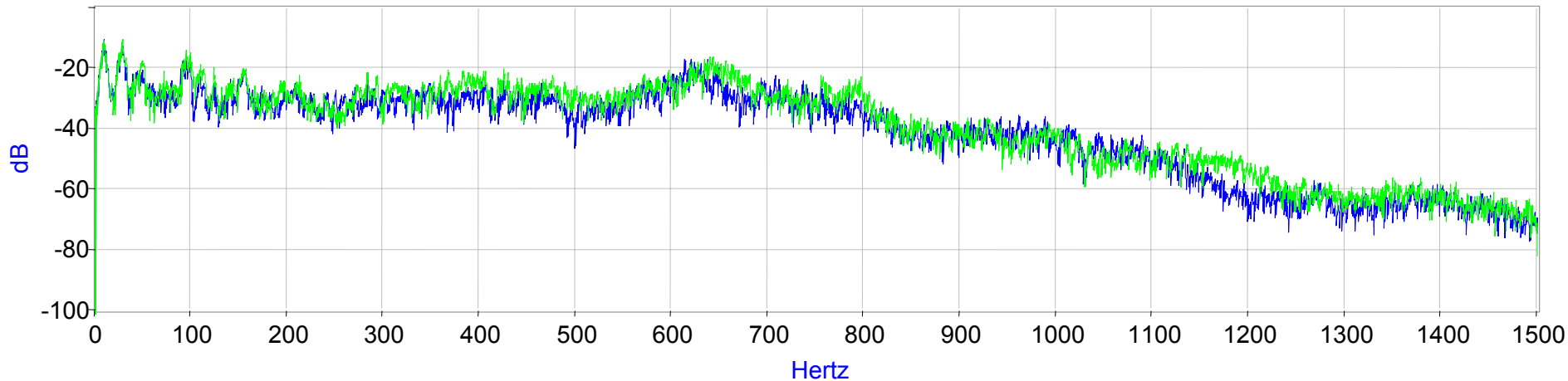

6/18/2005—File 30 (No Brake)

Truck Longitudinal Accel, blue = WABTEC/SAB-WABCO, green = Knorr

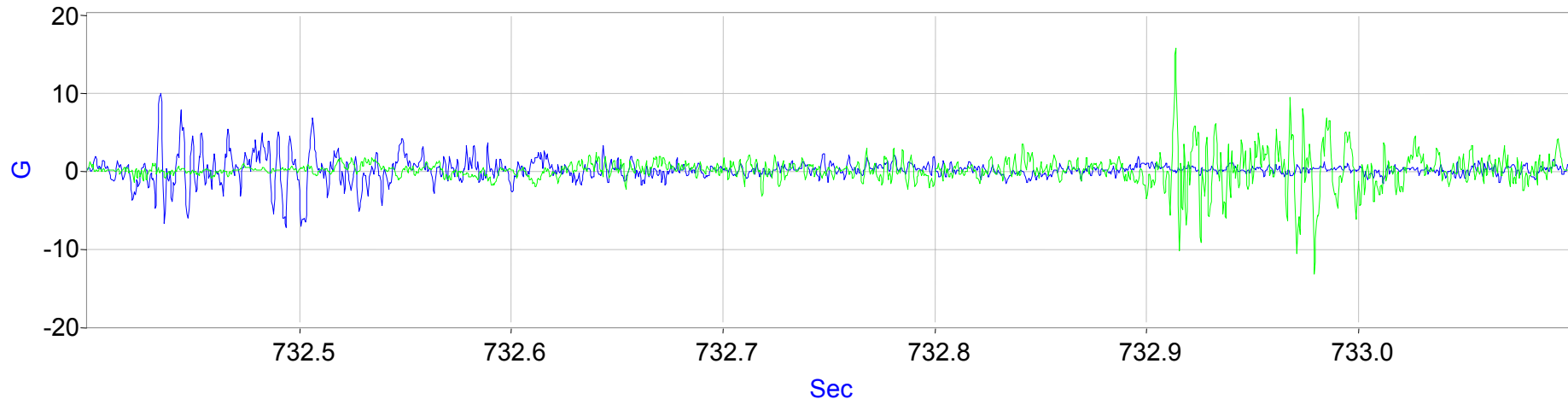

PSD of Truck Longitudinal Accel, 16384 points, 5 point moving avg, t = 732 s,
blue = WABTEC/SAB-WABCO, green = Knorr

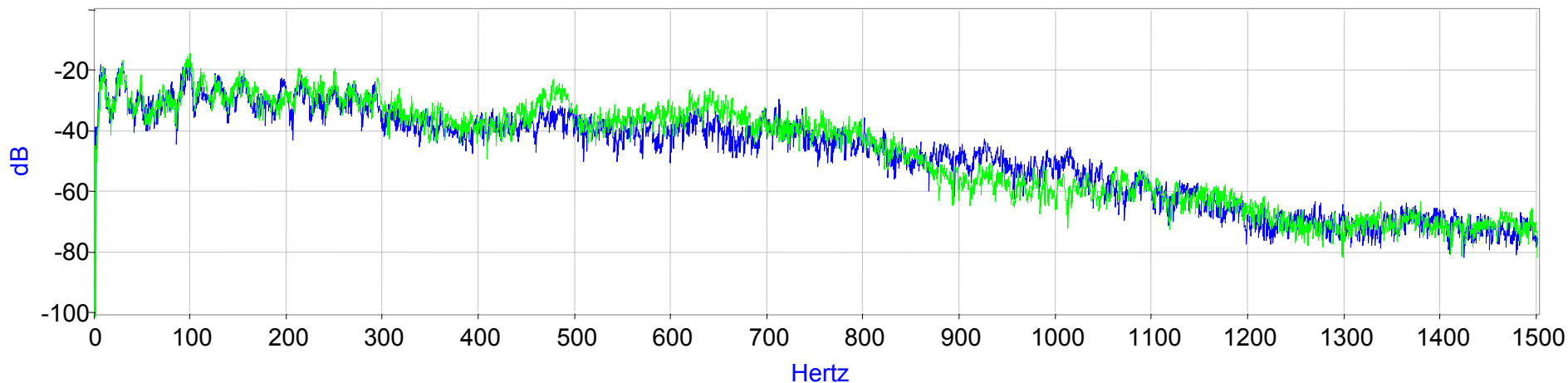

BOP Responses

- June 18, 2005 File 24, t = 310–No BOP, Braking
- June 18, 2005 File 24, t = 581–BOP, Braking
- June 18, 2005 File 30, t = 732–BOP, Response to Impact

6/18/2005—File 24

BOP, blue = WABTEC/SAB-WABCO, green = Knorr

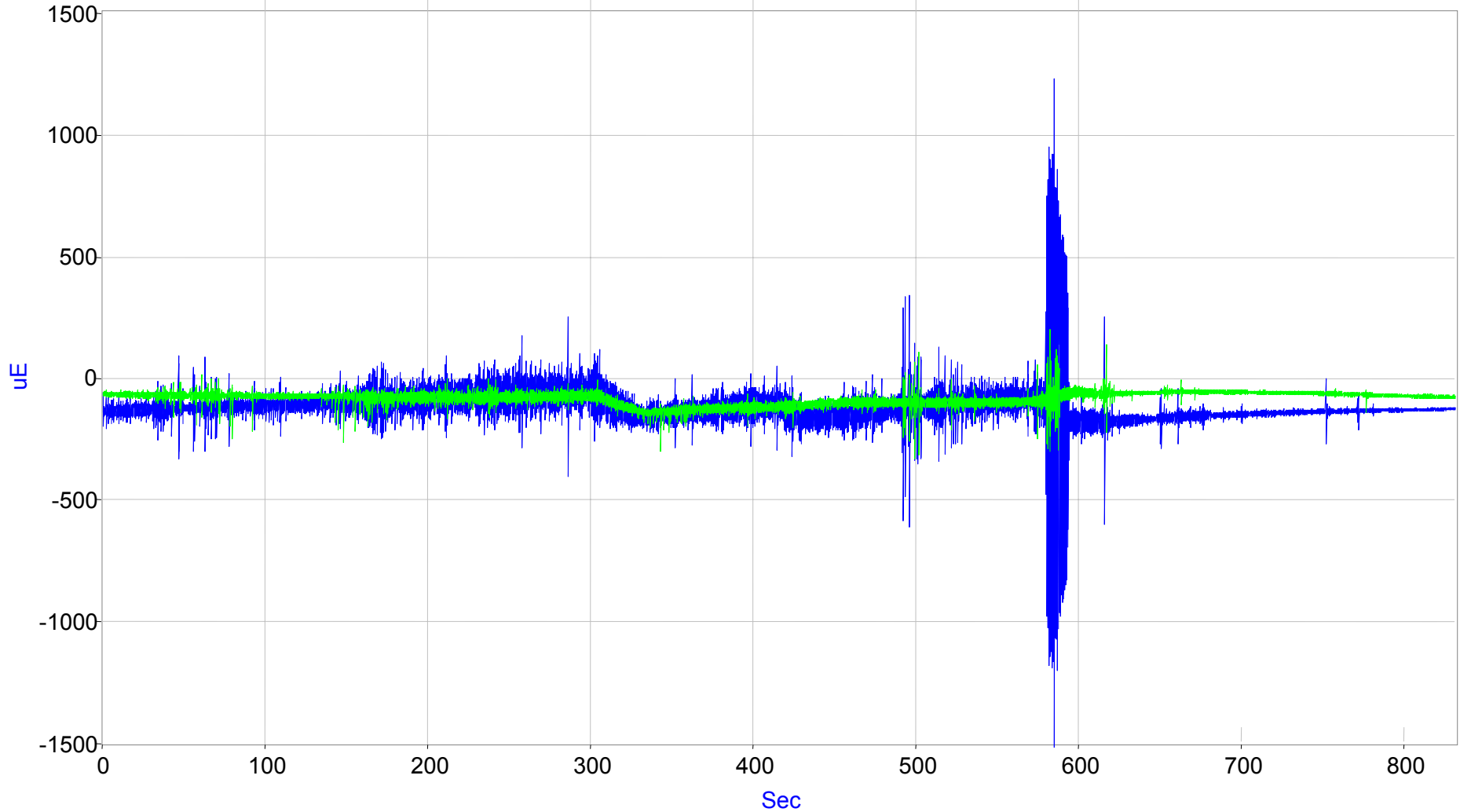

F-106

6/18/2005–File 24 (Brake, No SO)

BOP, blue = WABTEC/SAB-WABCO, green = Knorr

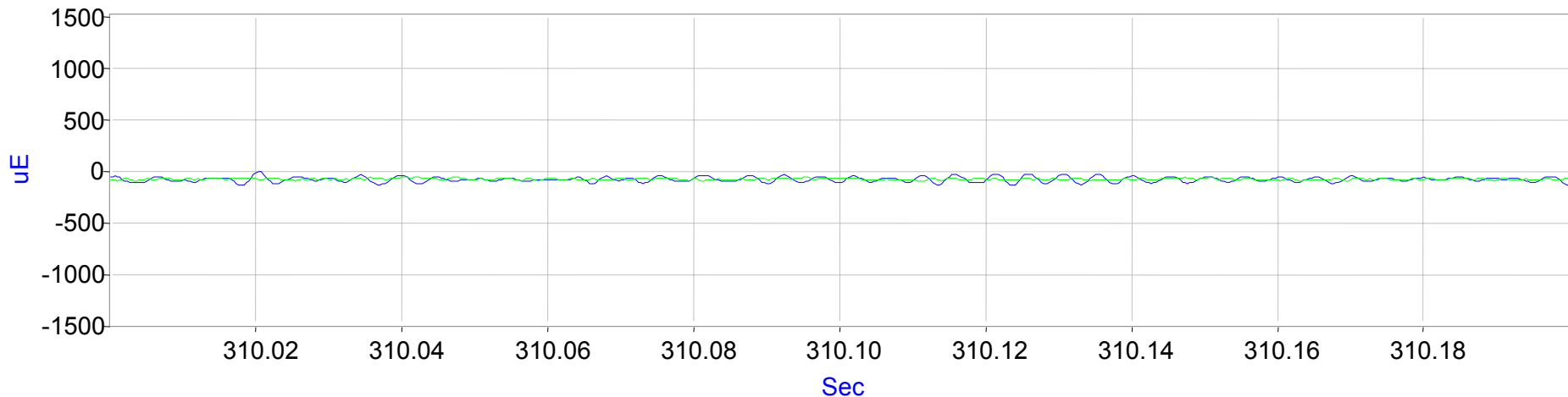

PSD of BOP, 16384 points, 5 point moving avg, t = 310 s,
blue = WABTEC/SAB-WABCO, green = Knorr

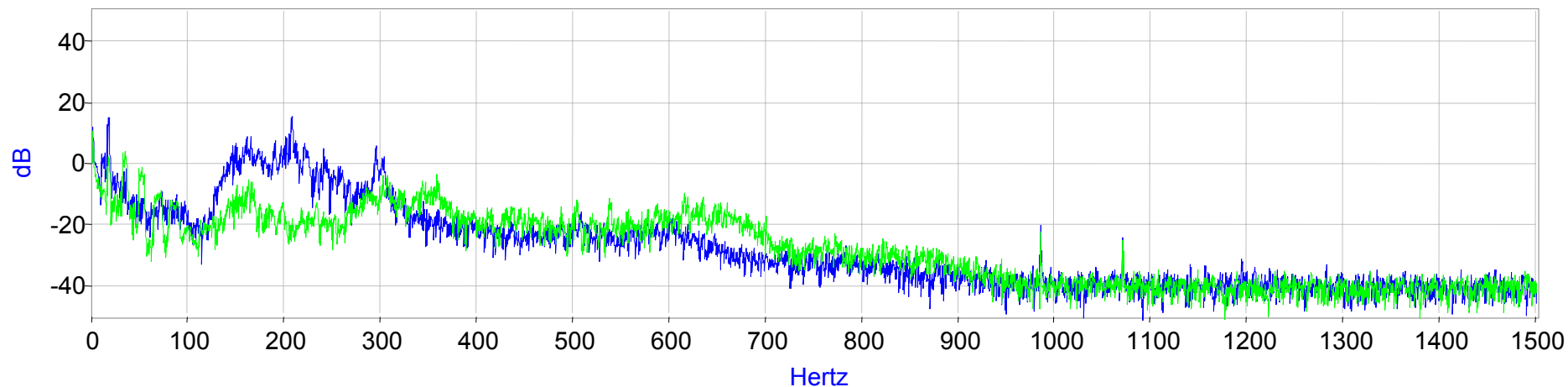

6/18/2005–File 24 (Brake, SO)

BOP, blue = WABTEC/SAB-WABCO, green = Knorr

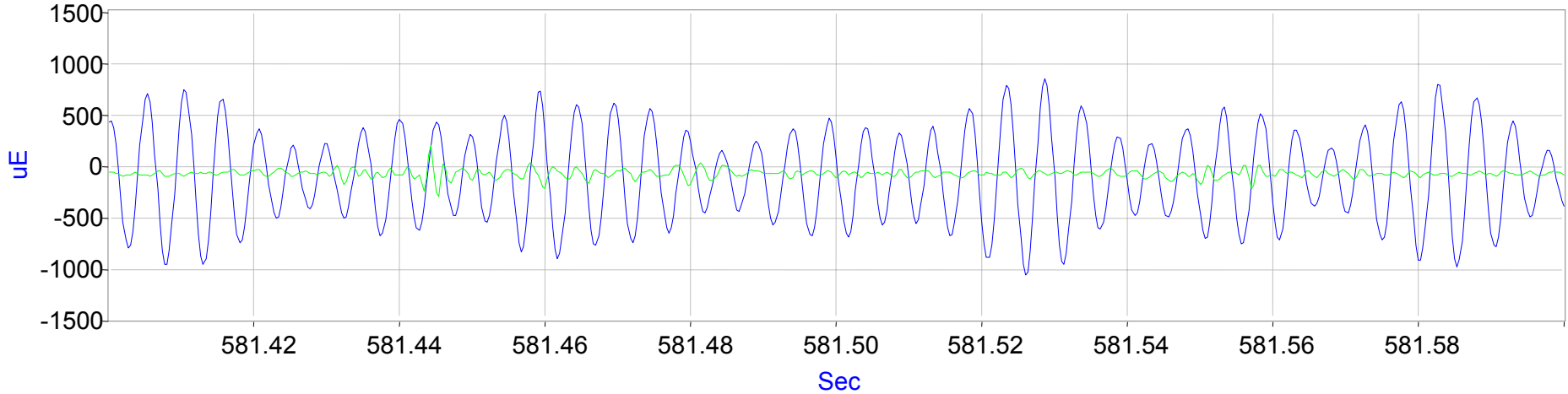

**PSD of BOP, 16384 points, 5 point moving avg, t = 581 s,
blue = WABTEC/SAB-WABCO, green = Knorr**

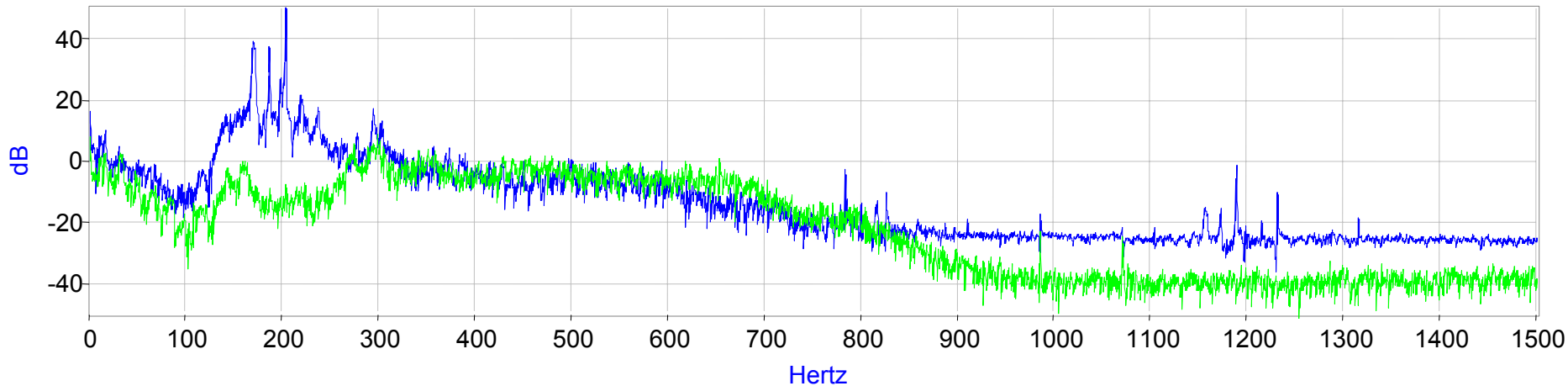

6/18/2005—File 30 (No Brake)

BOP, blue = WABTEC/SAB-WABCO, green = Knorr

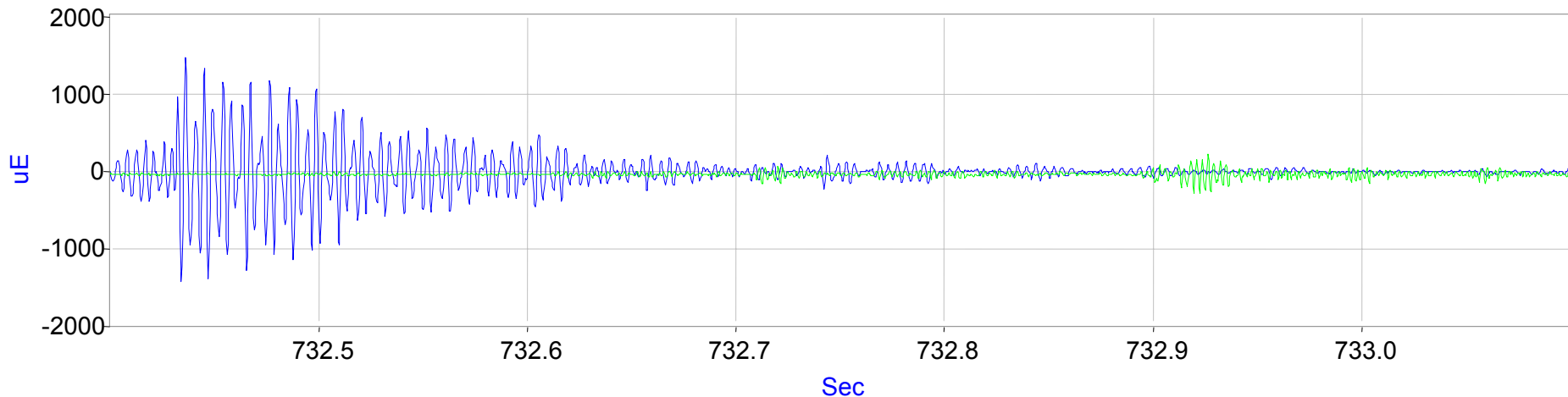

PSD of BOP, 16384 points, 5 point moving avg, t = 732 s,
blue = WABTEC/SAB-WABCO, green = Knorr

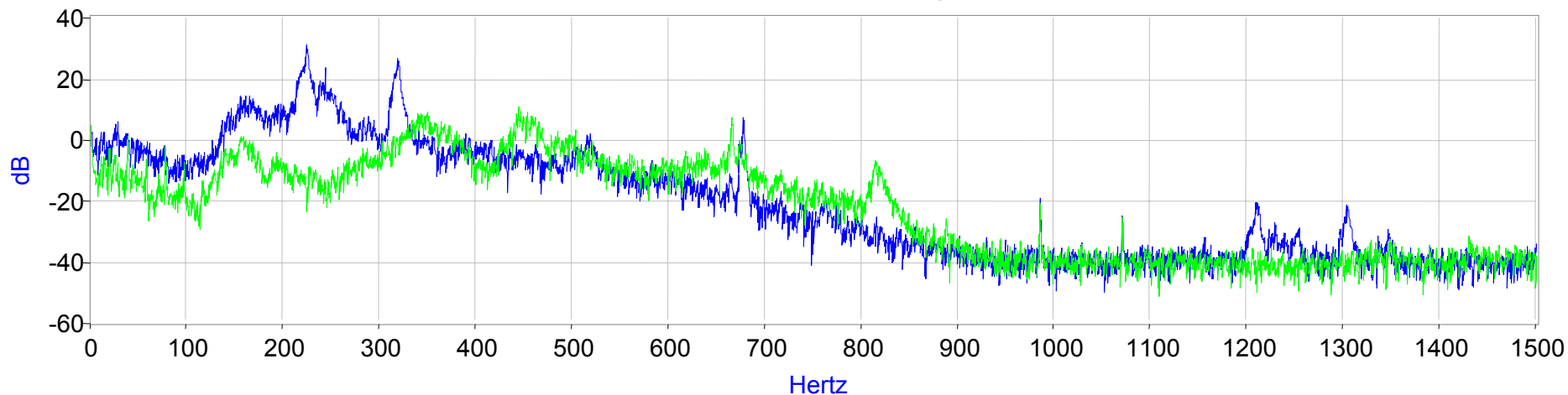

Plots of Axle Vertical Accelerations Exceeding 100 G

Day 1–May 16, 2005

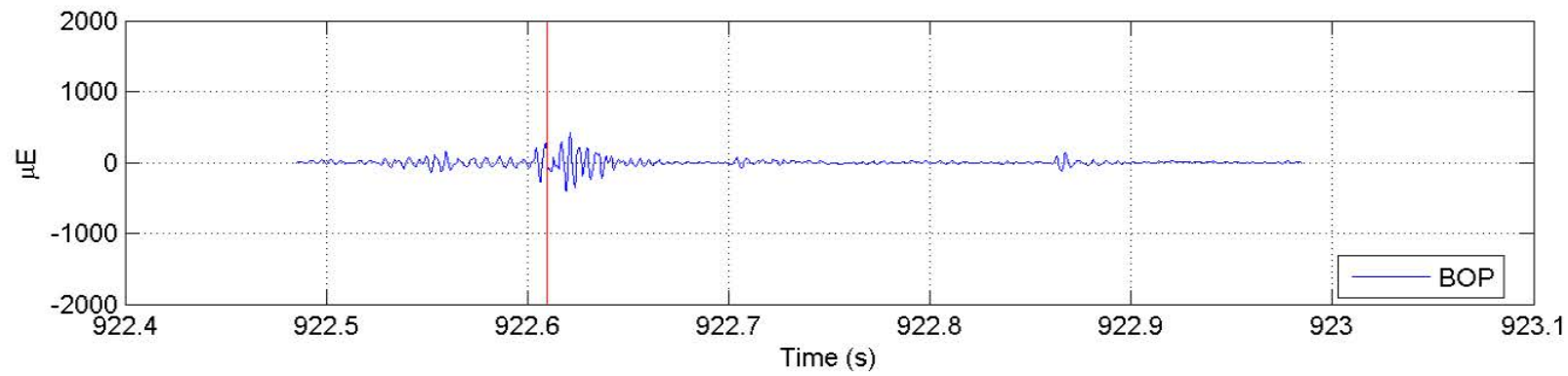
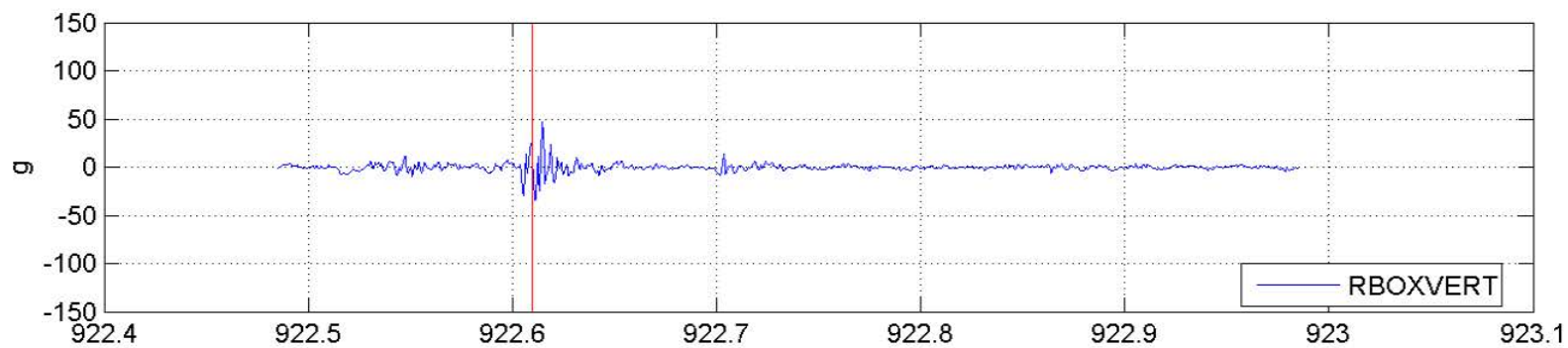
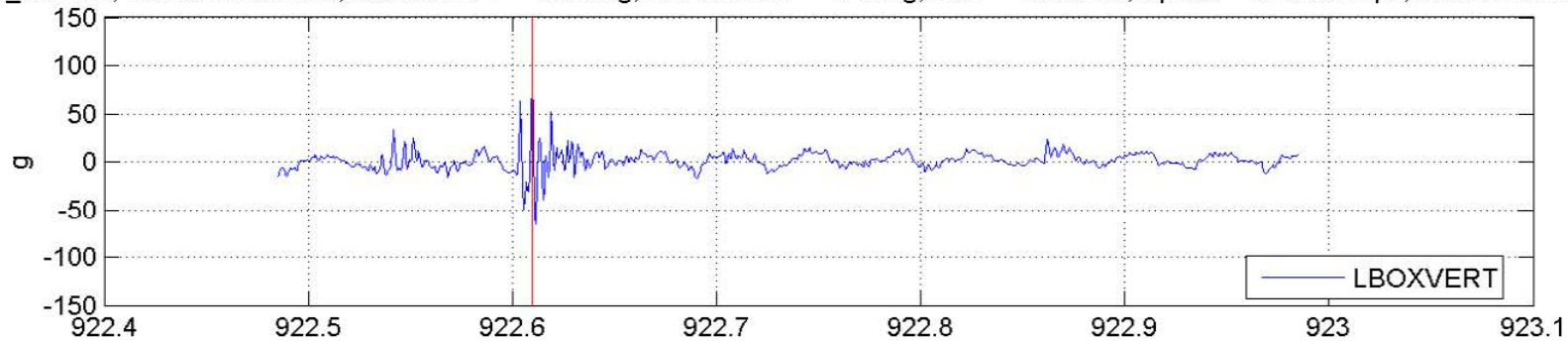

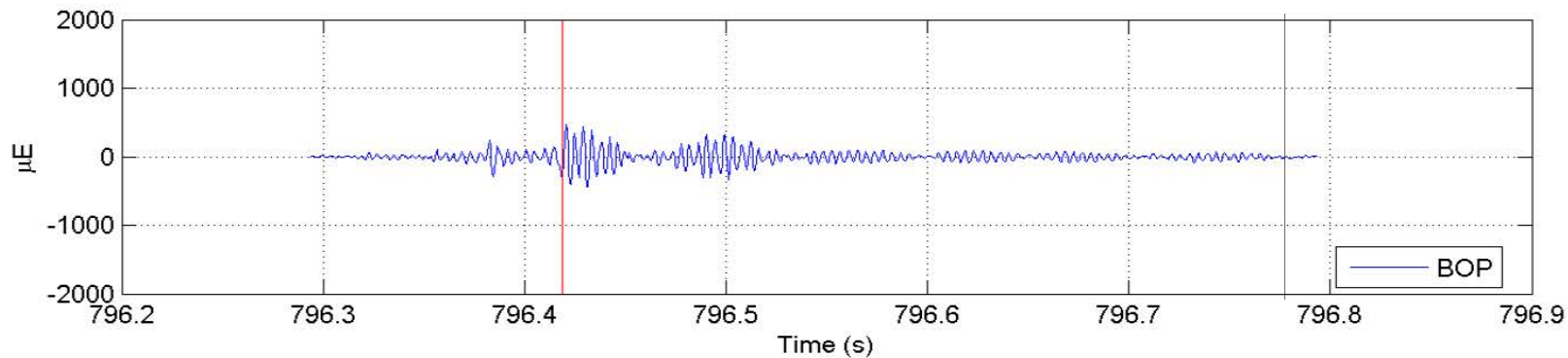
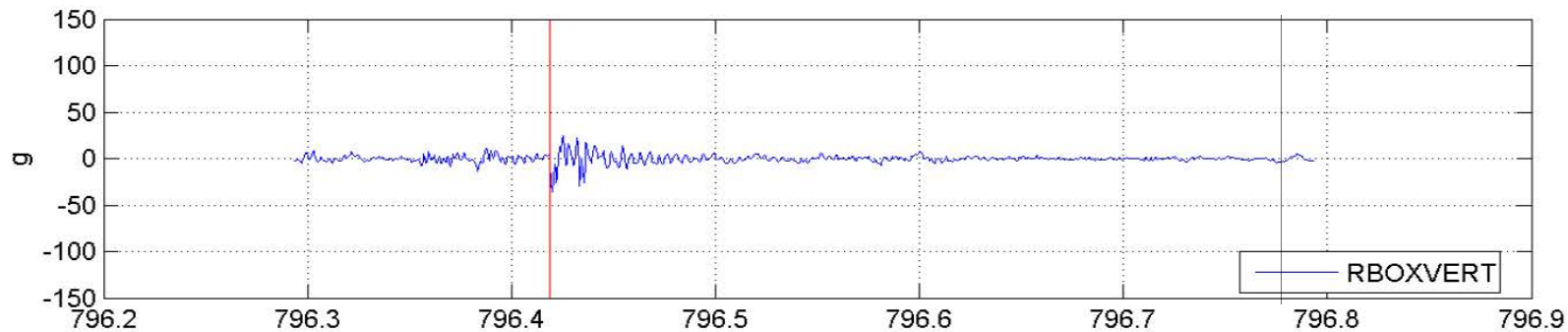
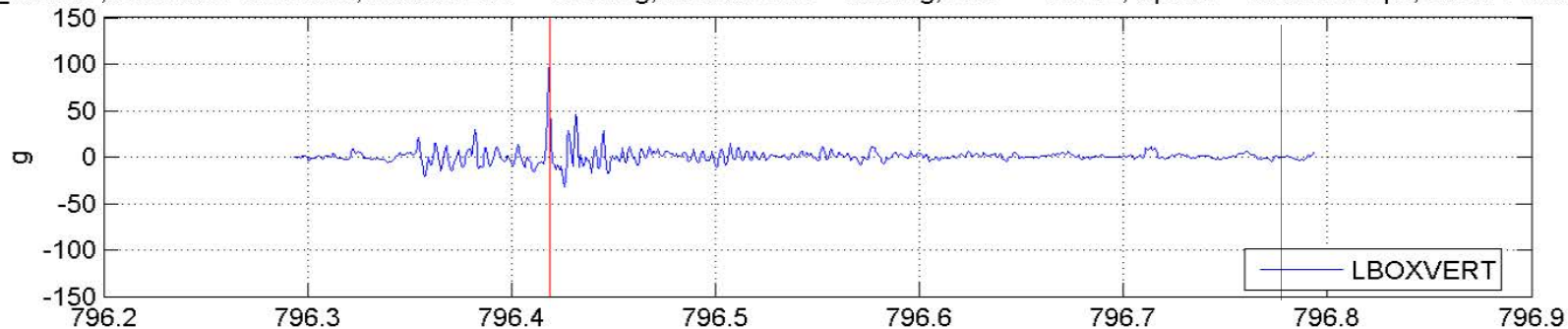

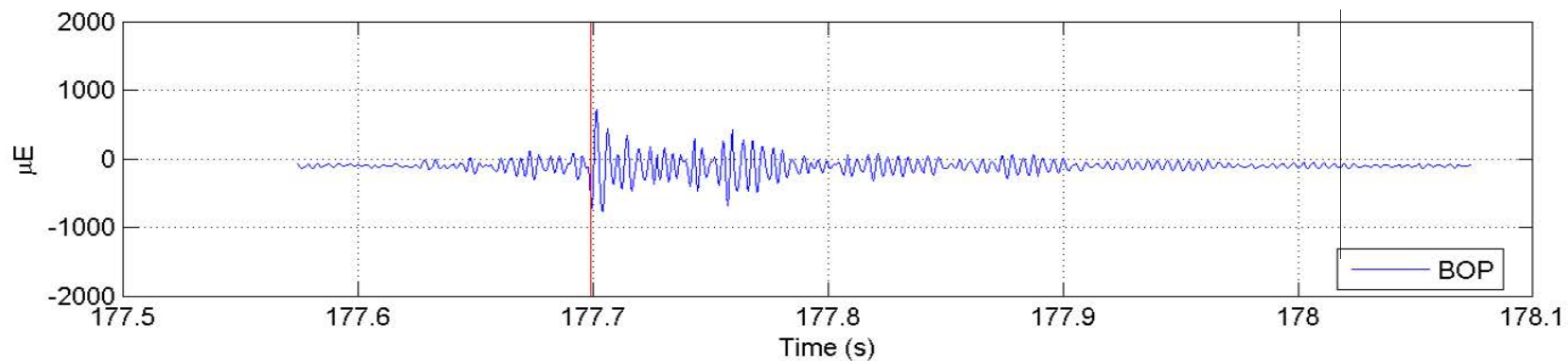
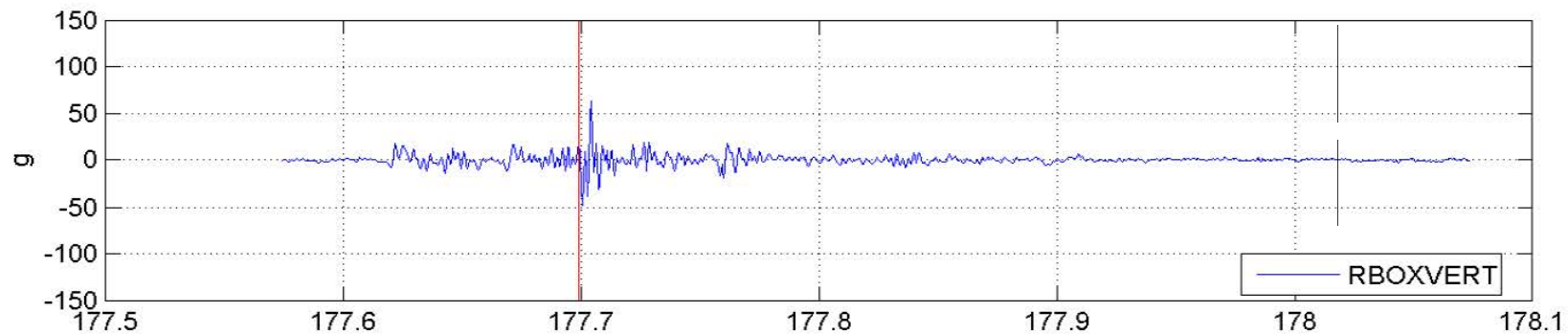
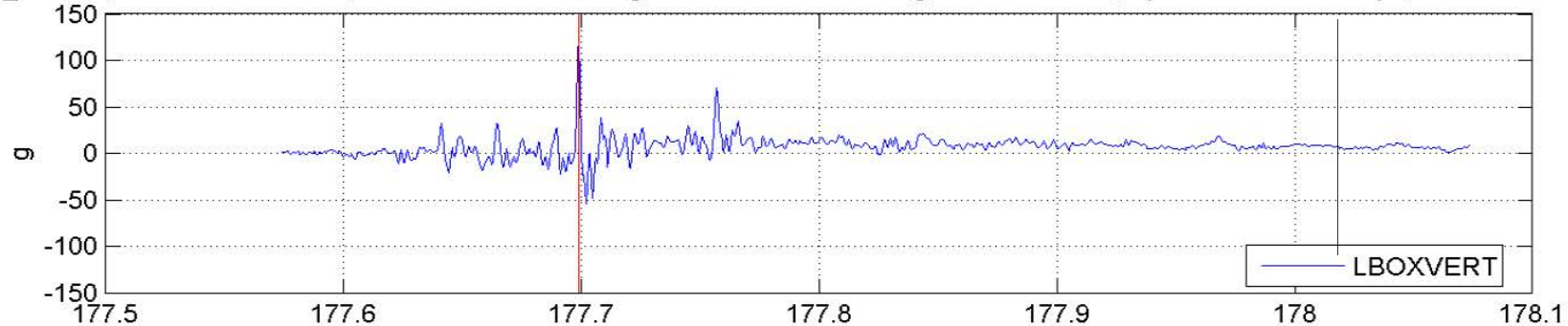

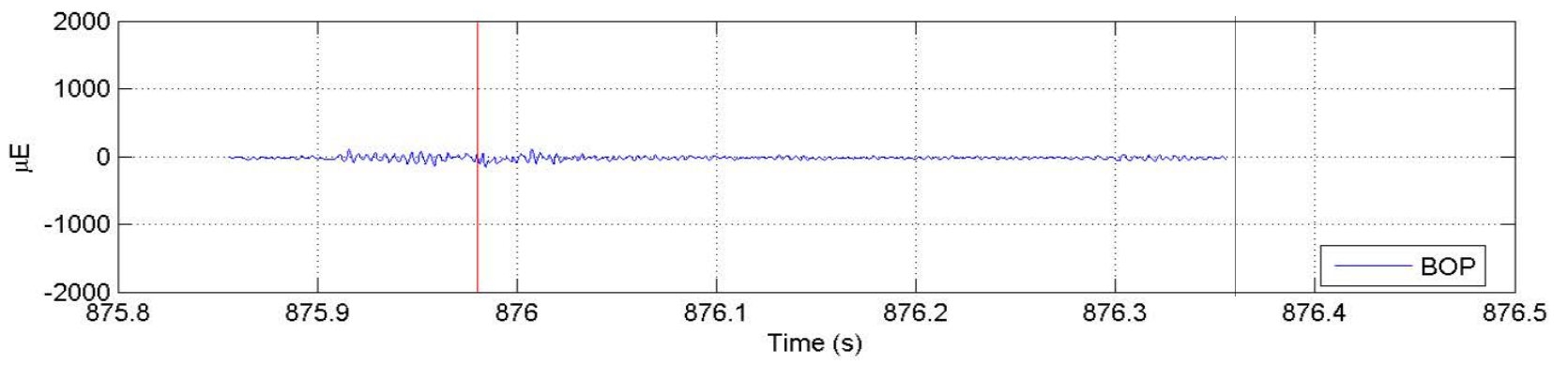
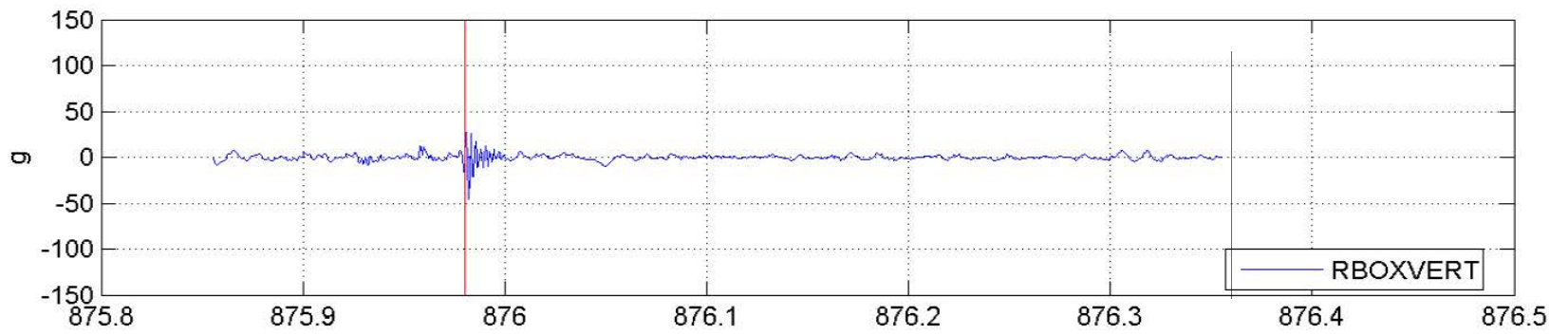
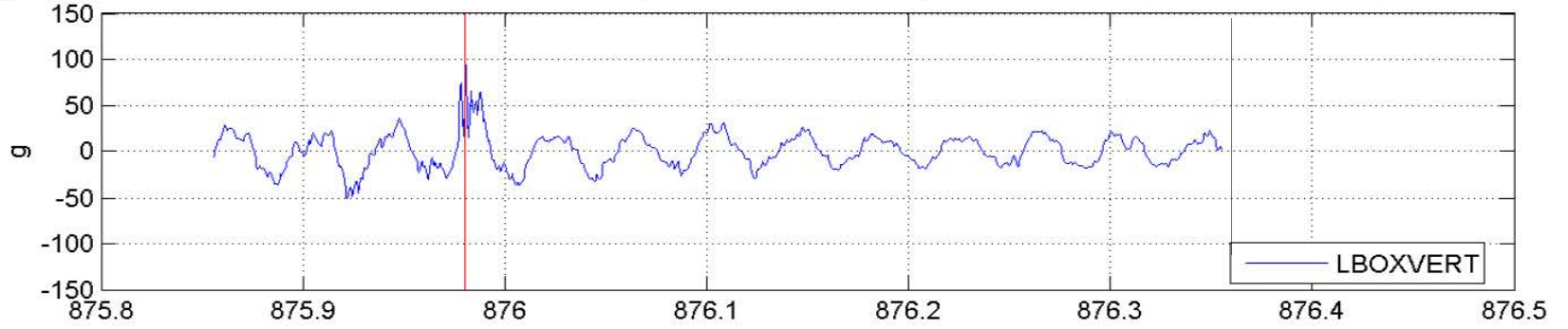

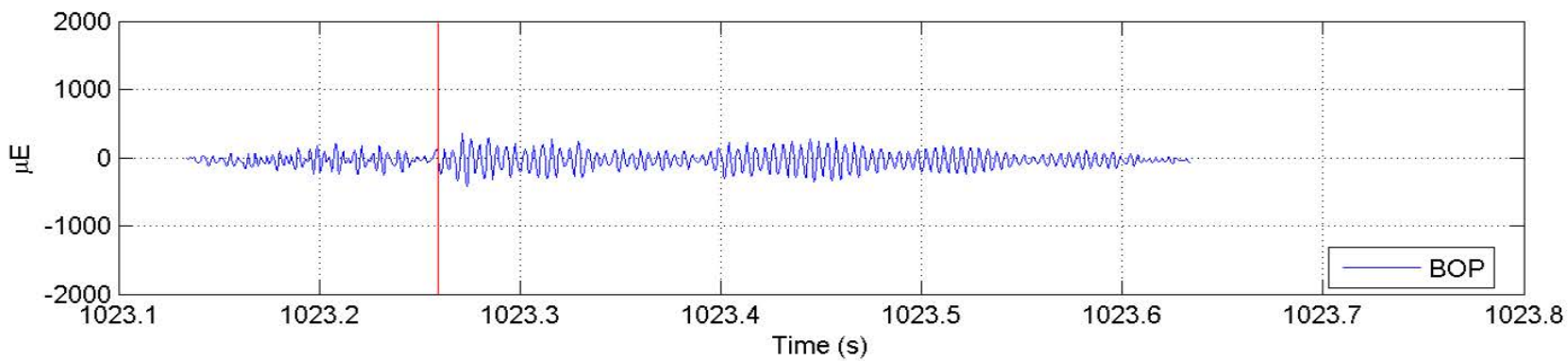
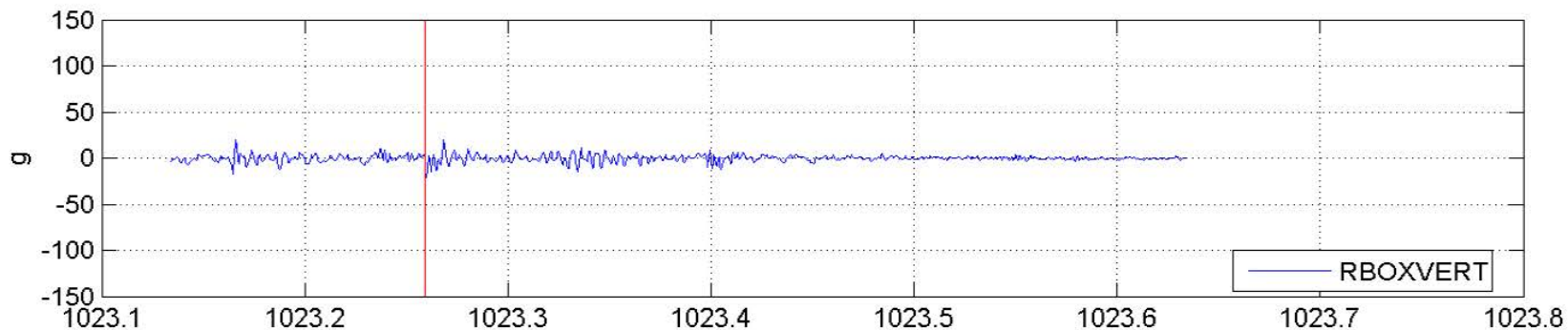
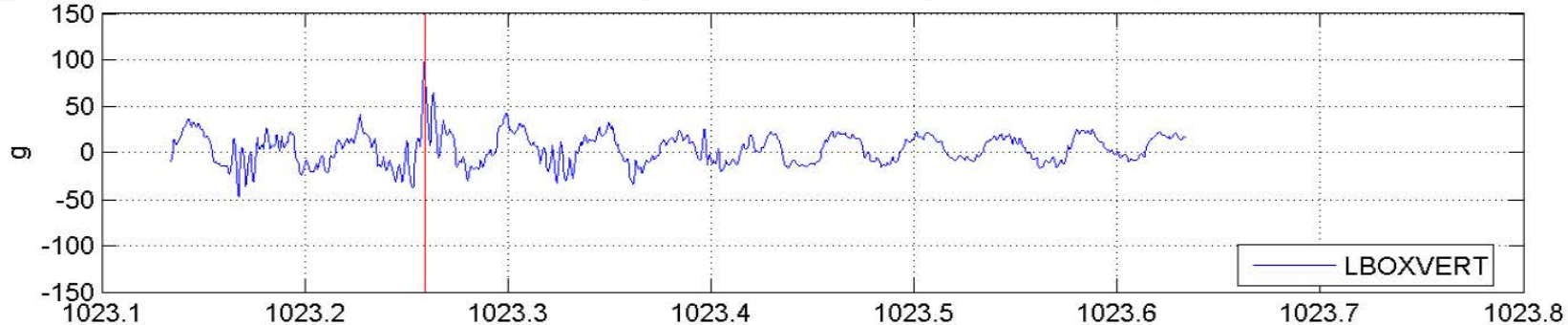

Day 2–May 17, 2005

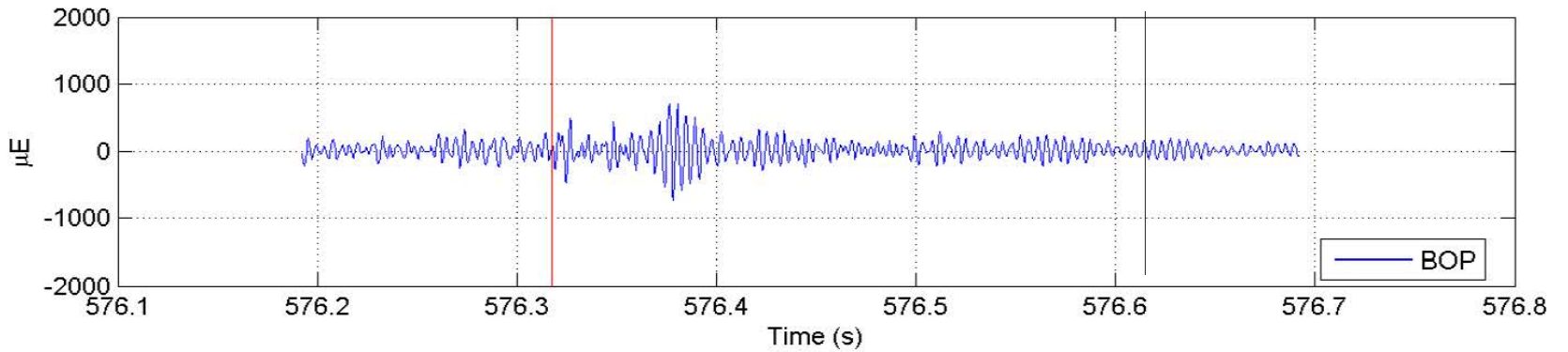
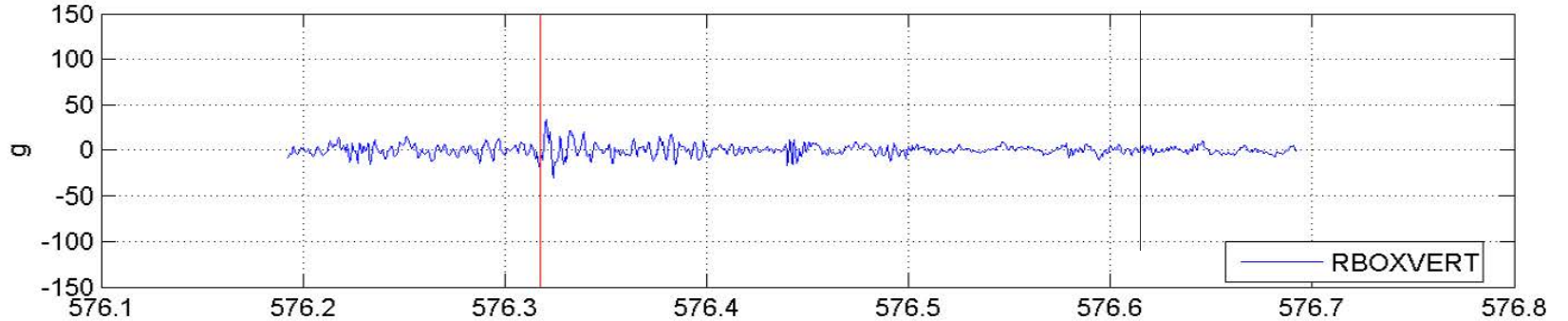
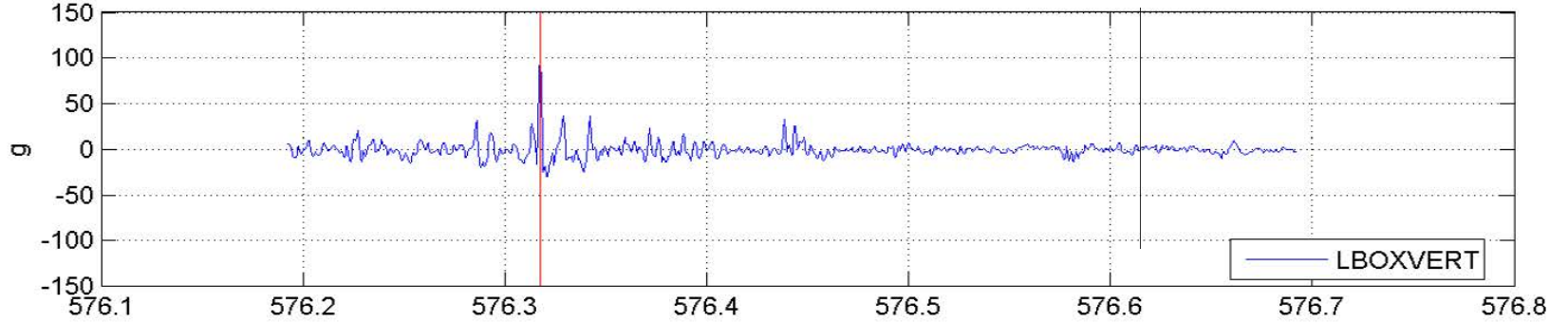

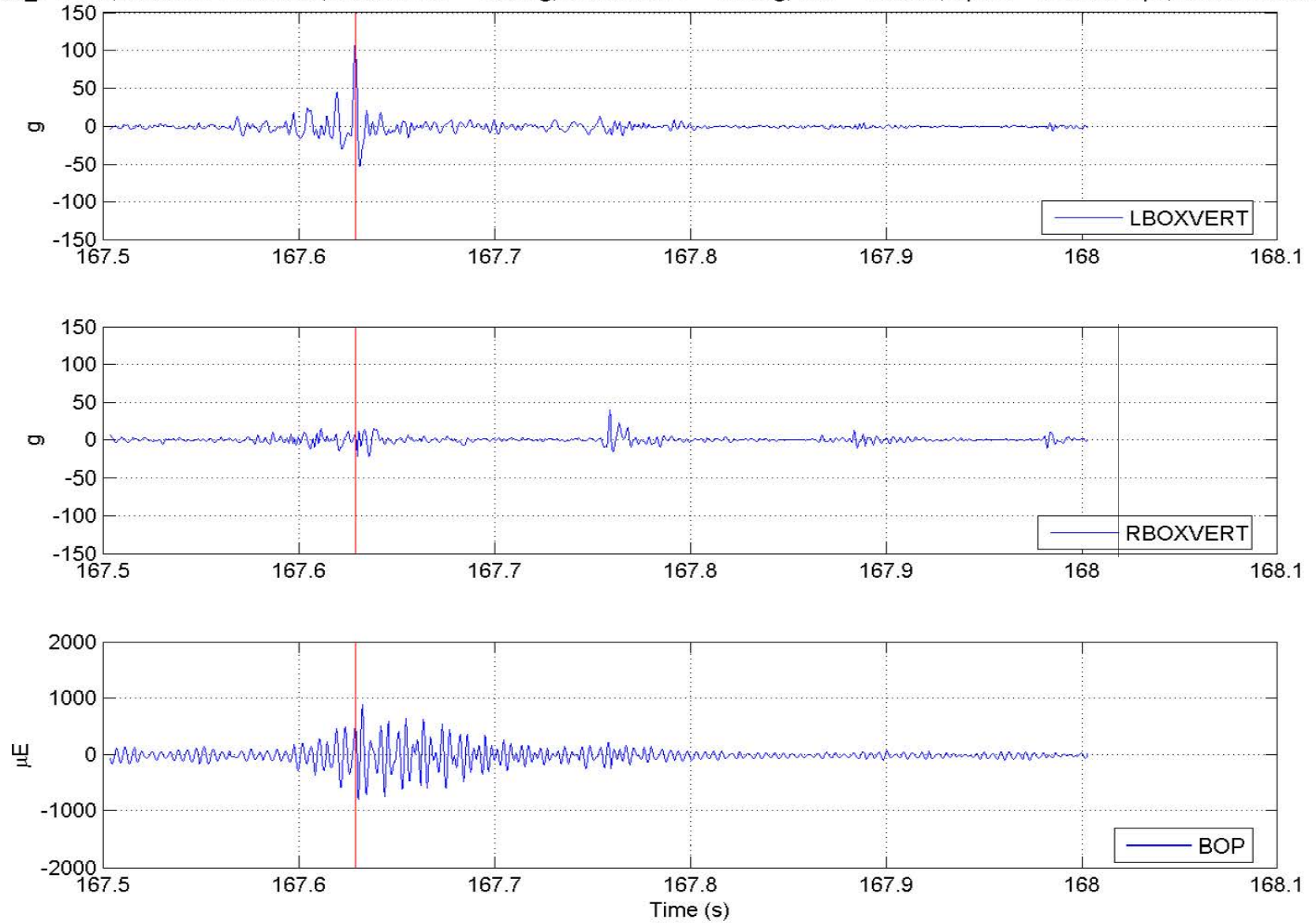

ile 051705_19.ABT, Location 110.5585 s, LBOXVERT = 109.96 g, RBOXVERT = 50.09 g, BOP = 719.5 μ E, Speed = 108.0293 mph, Brake Pressure = 0.881

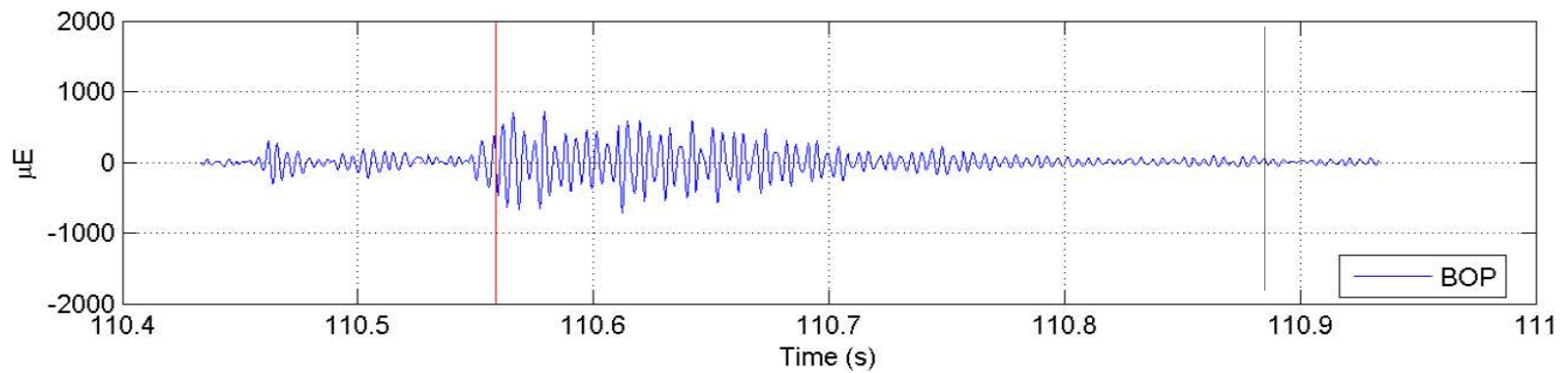
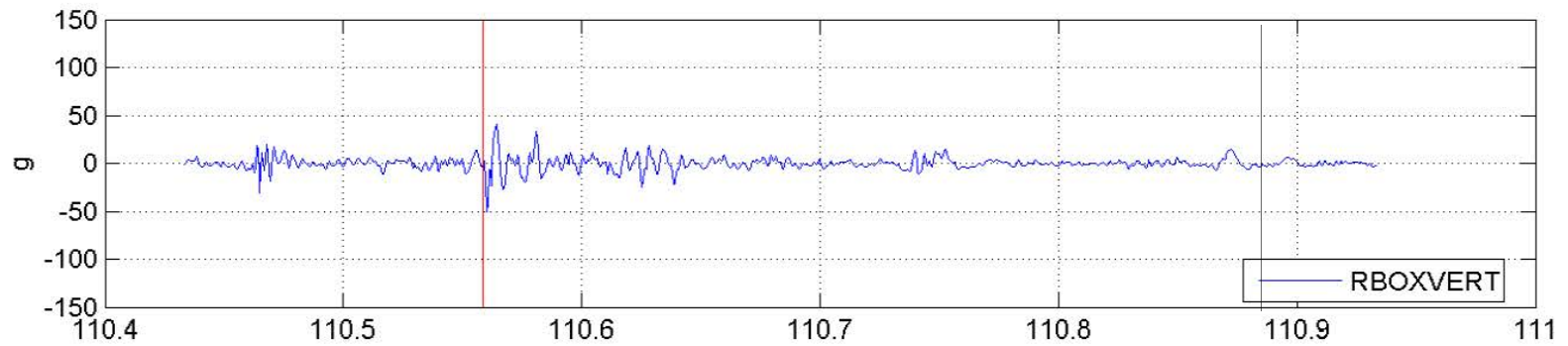
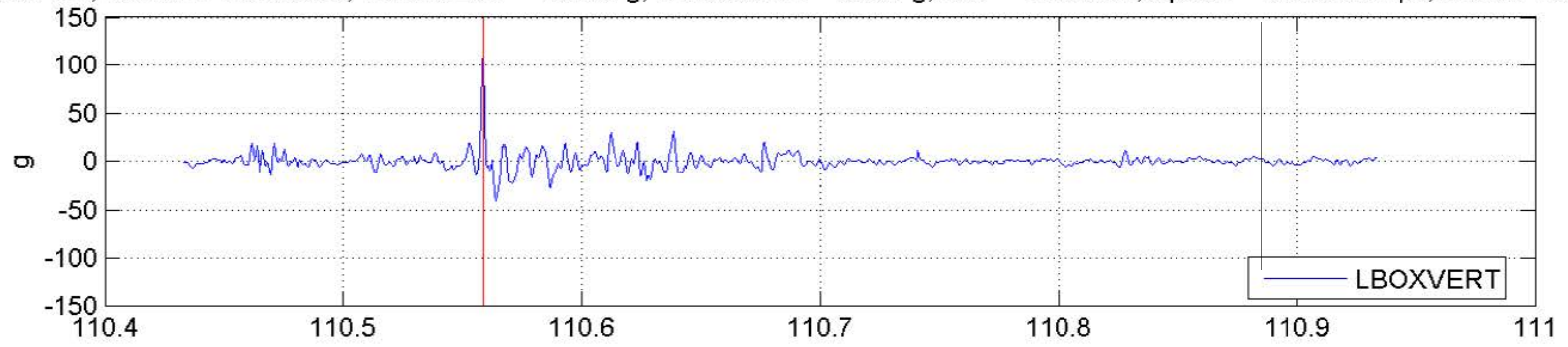

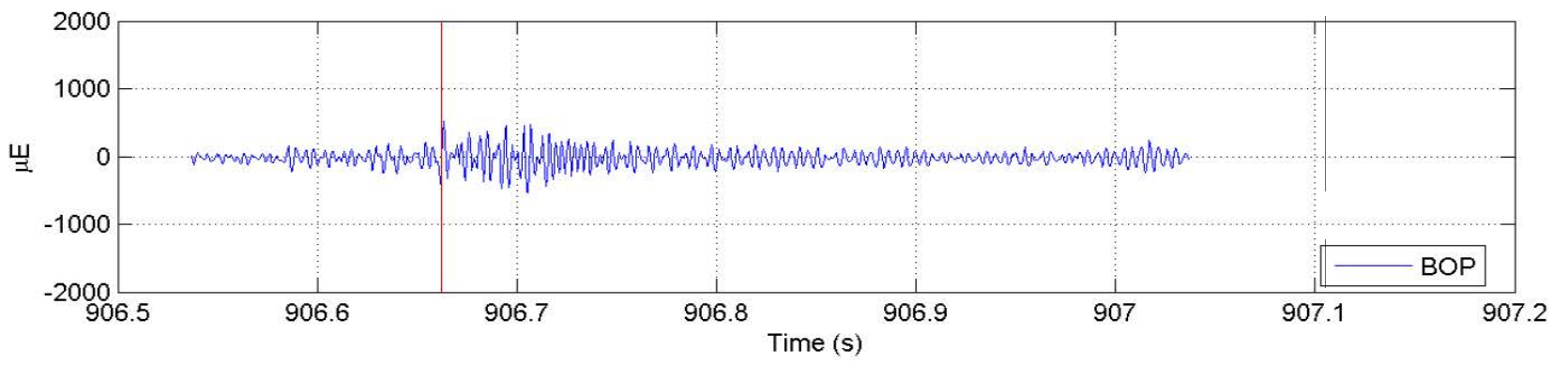
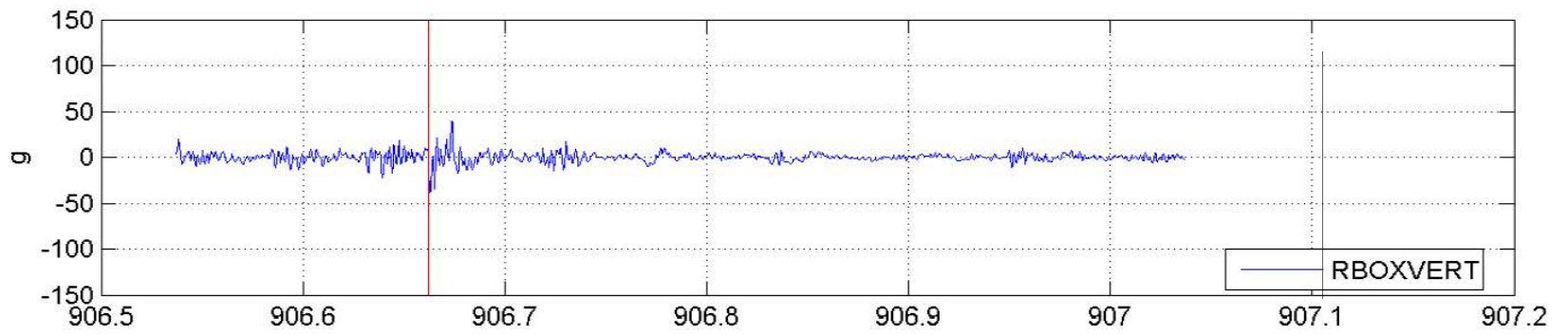
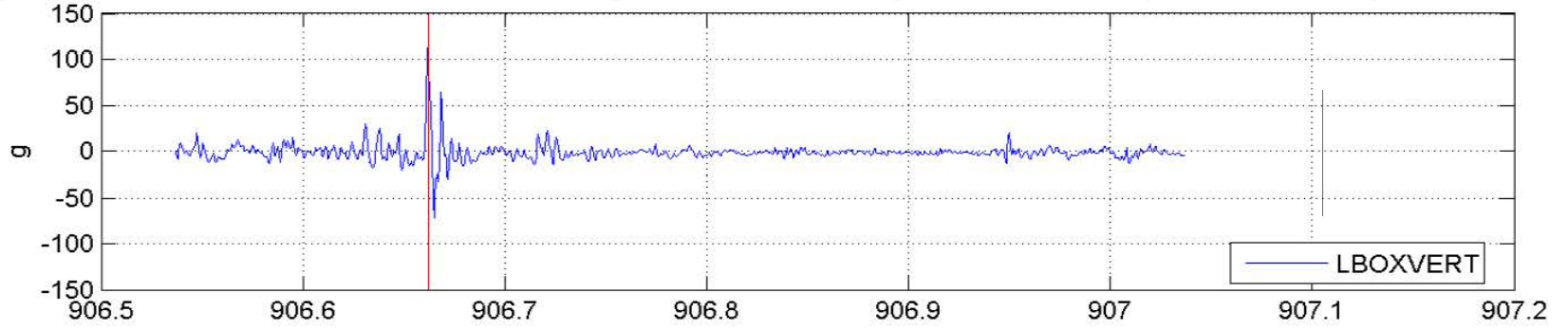

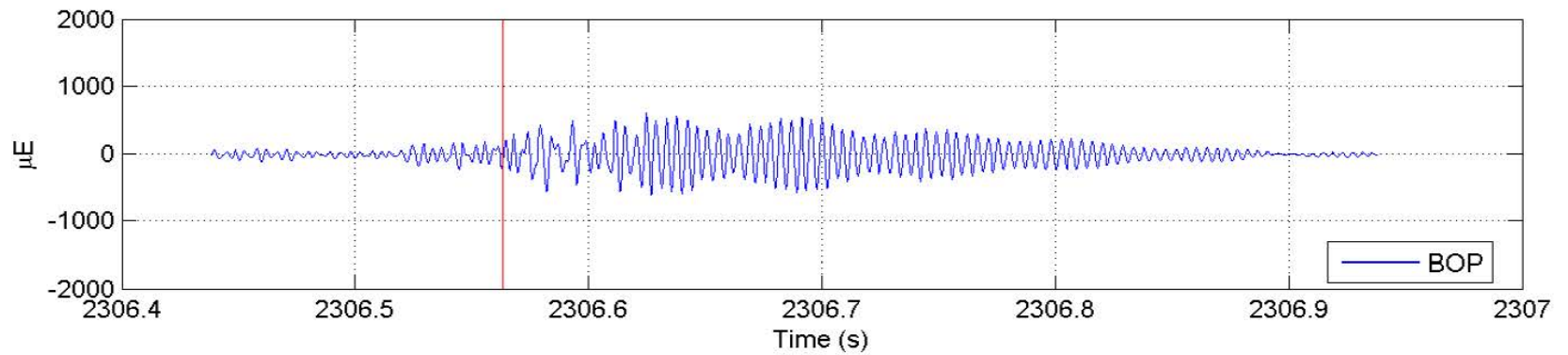
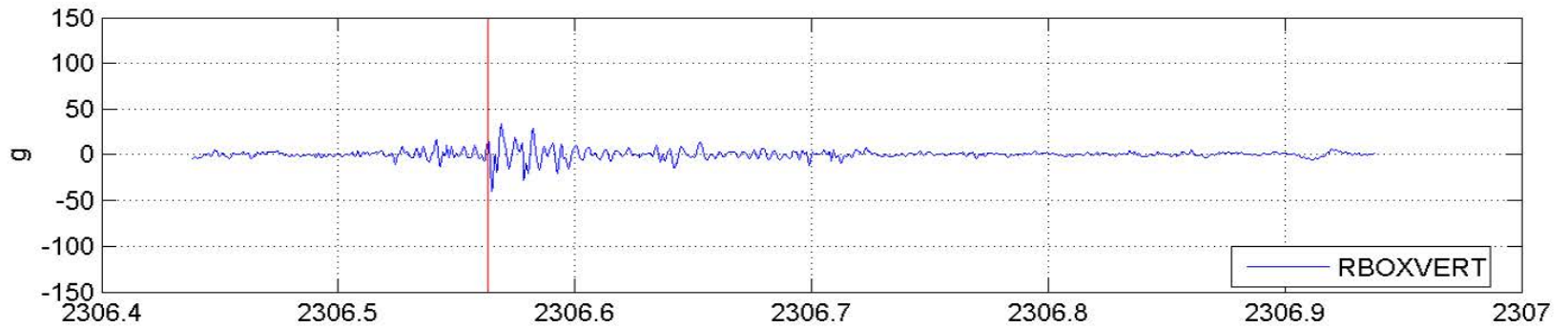
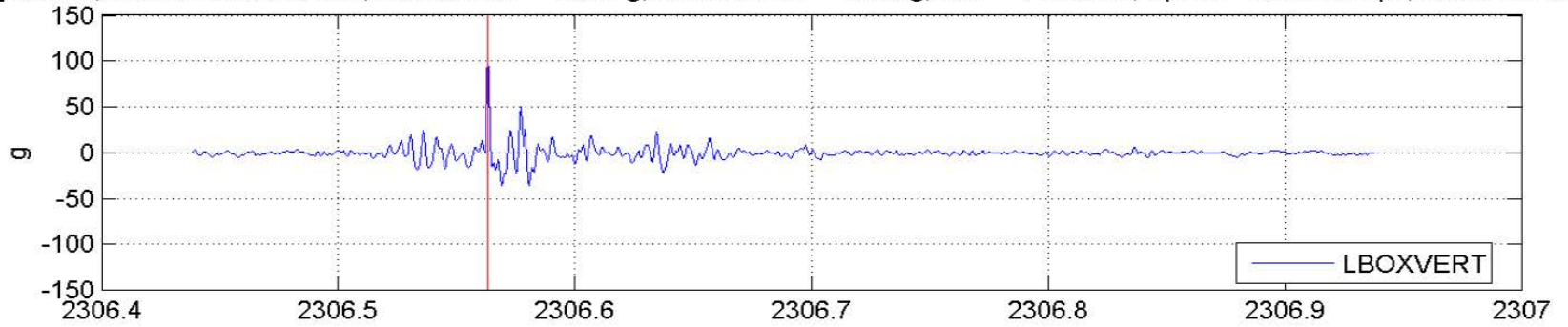

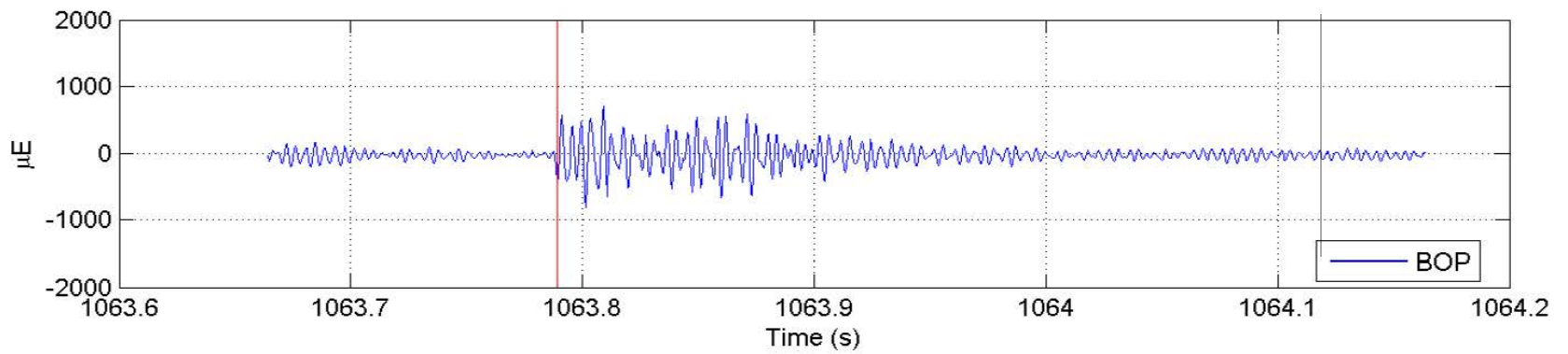
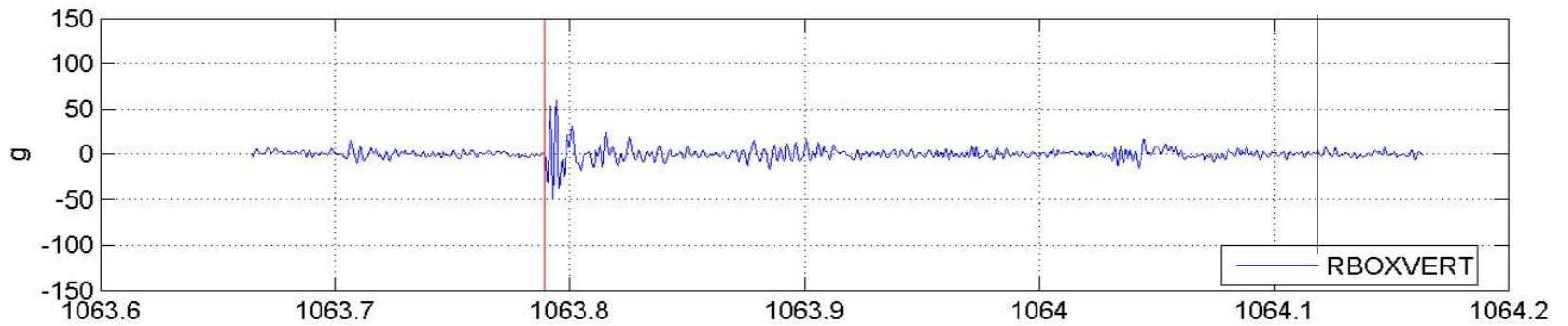
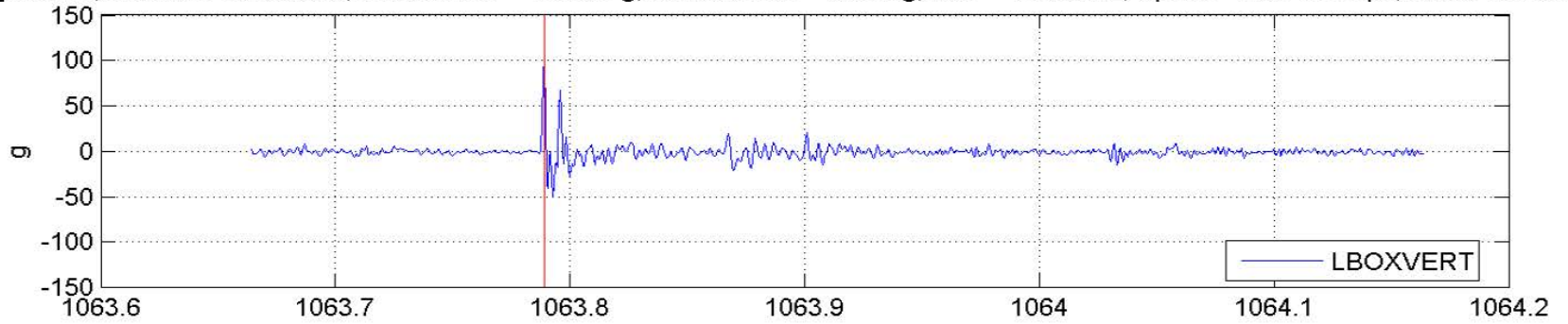

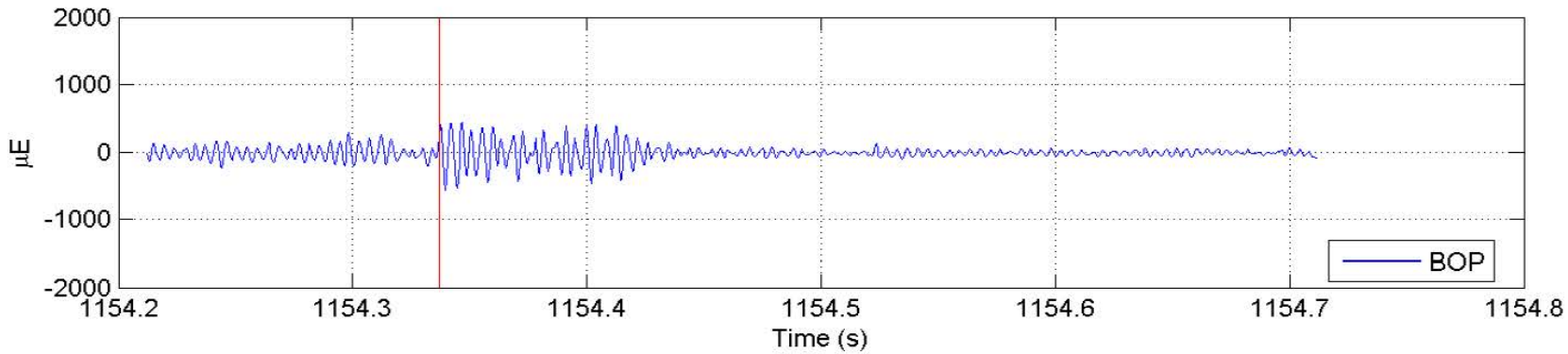
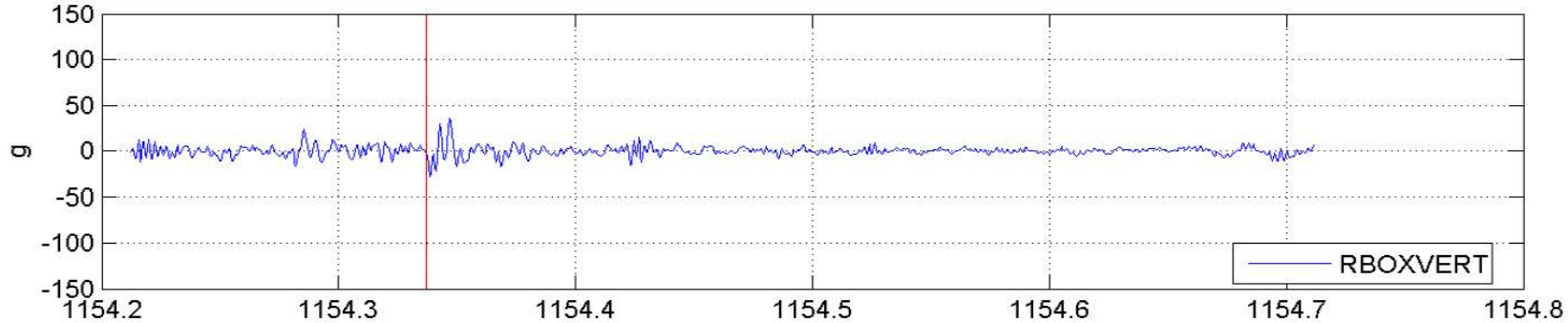
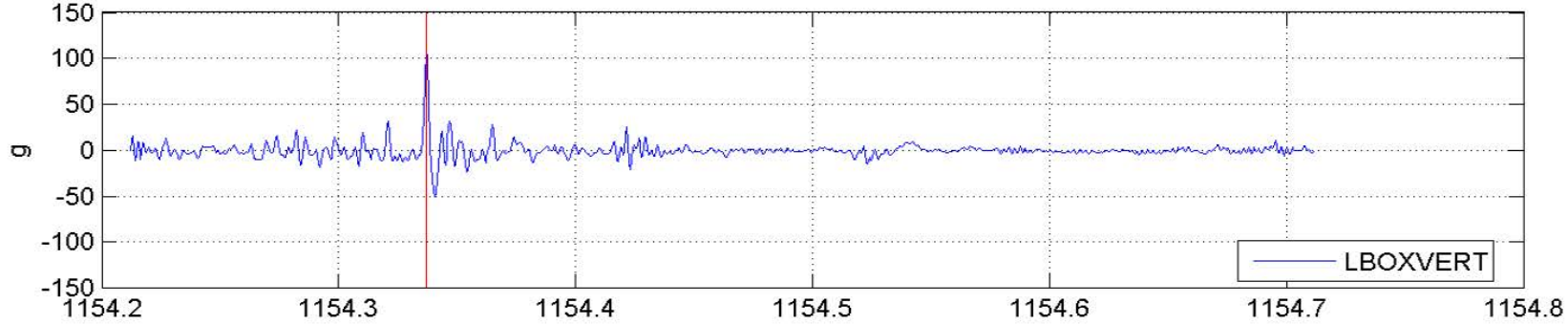

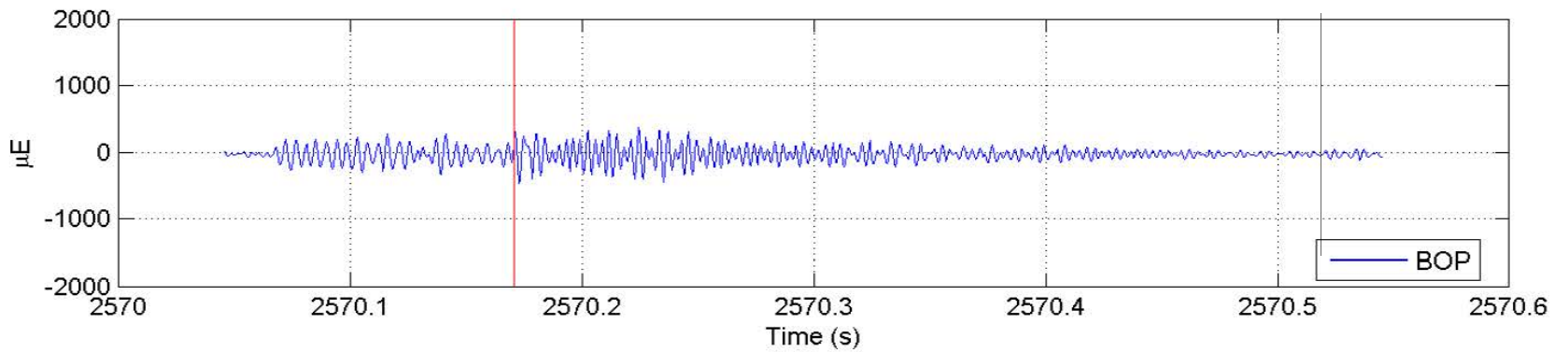
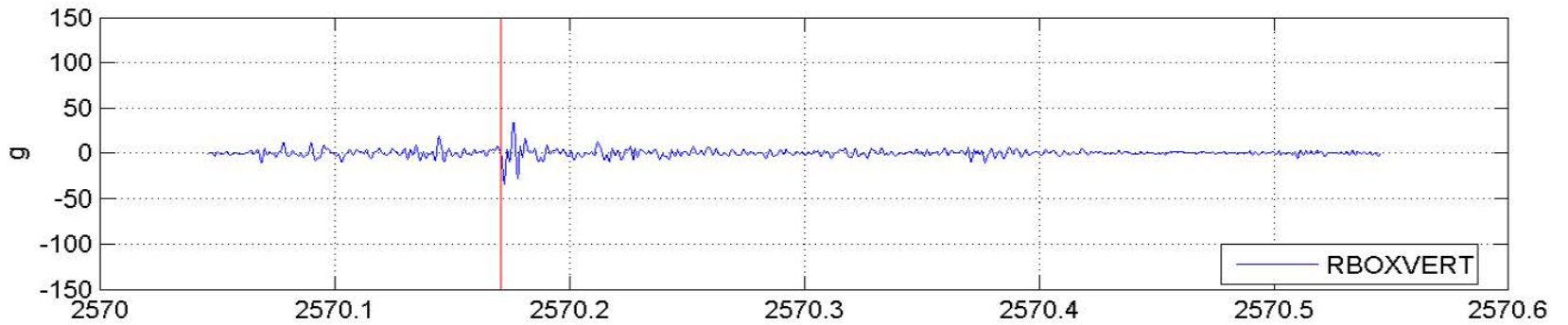
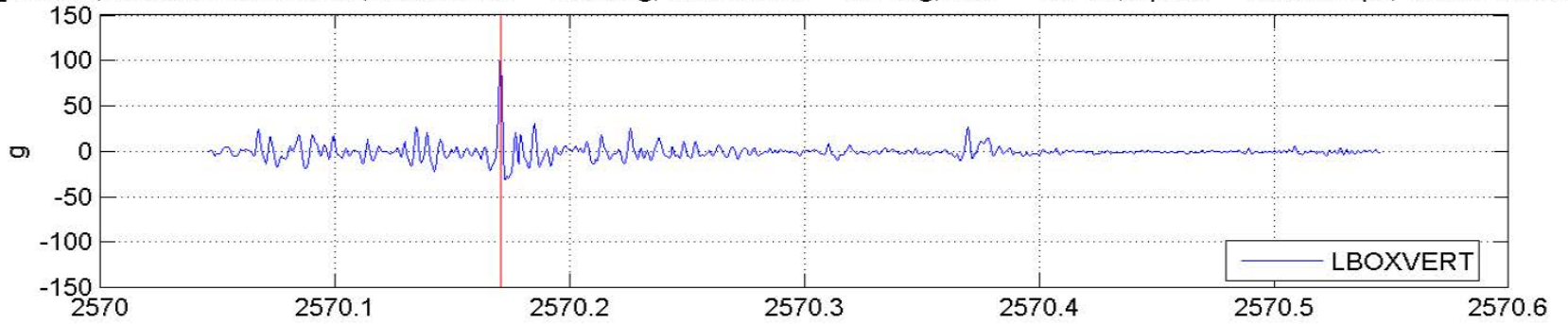

Day 3–May 26, 2005

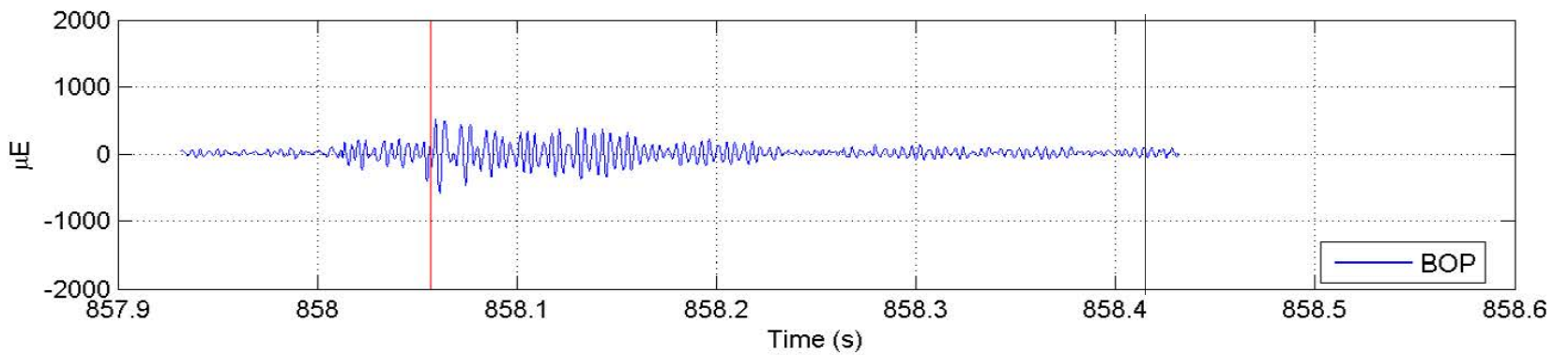
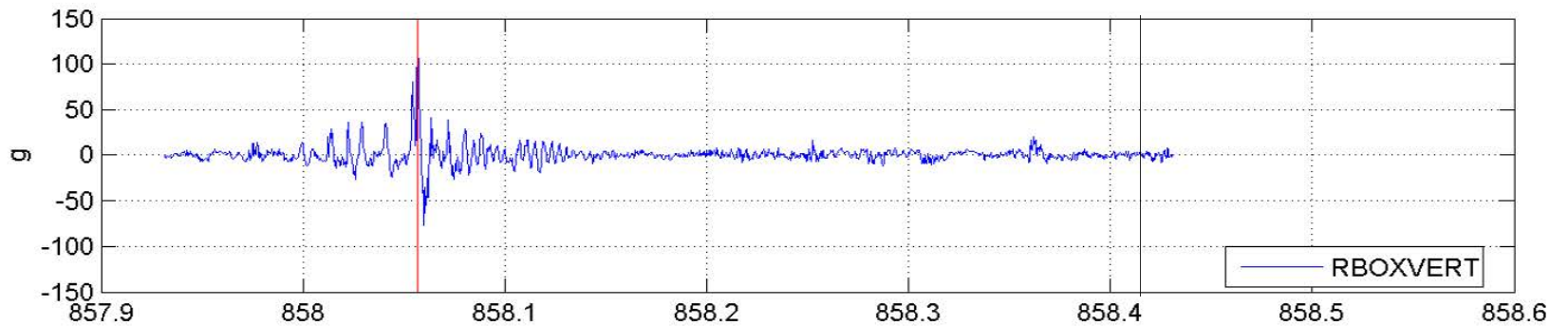
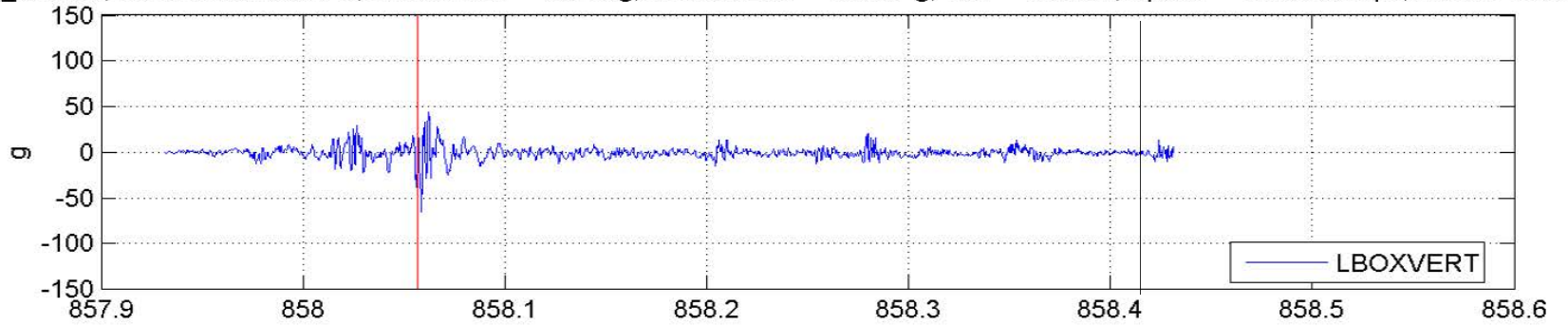

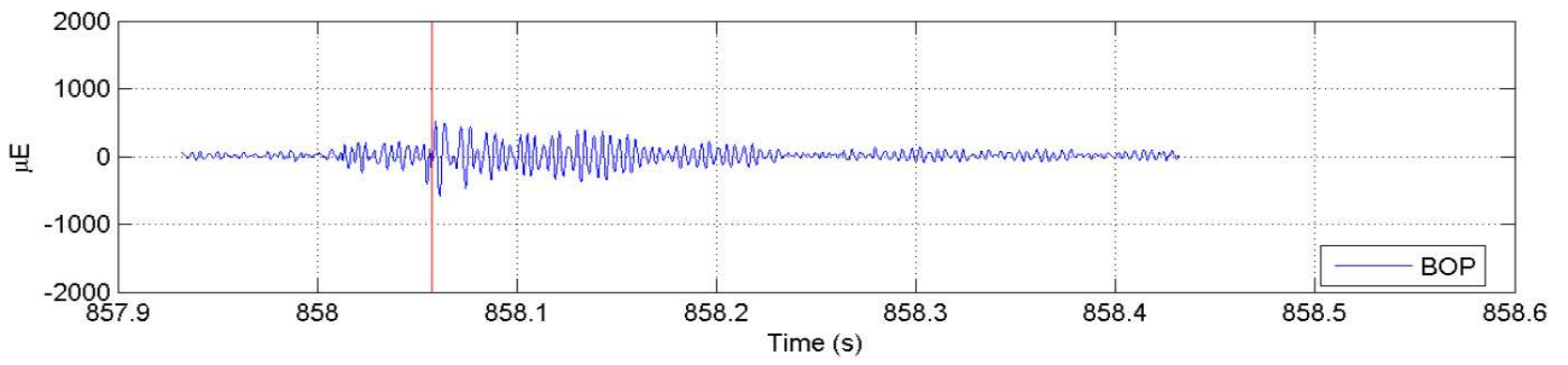
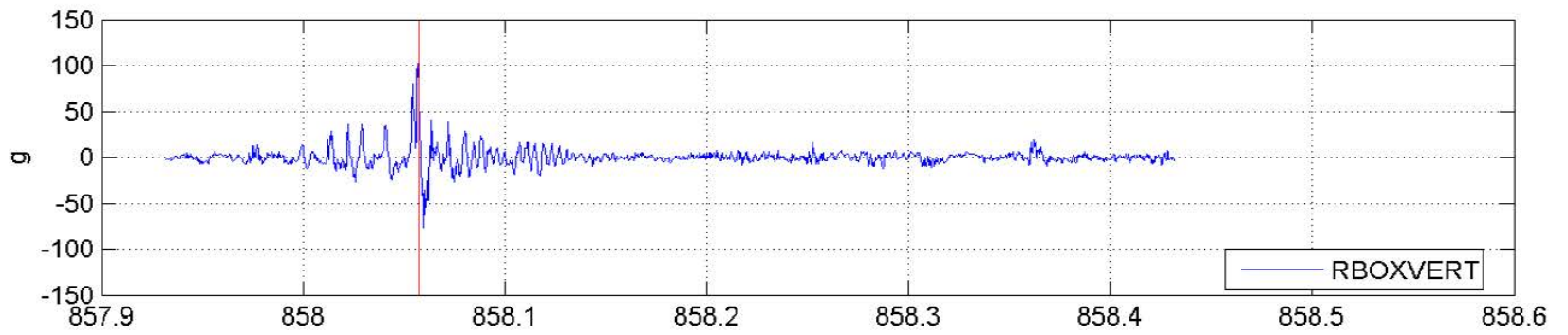
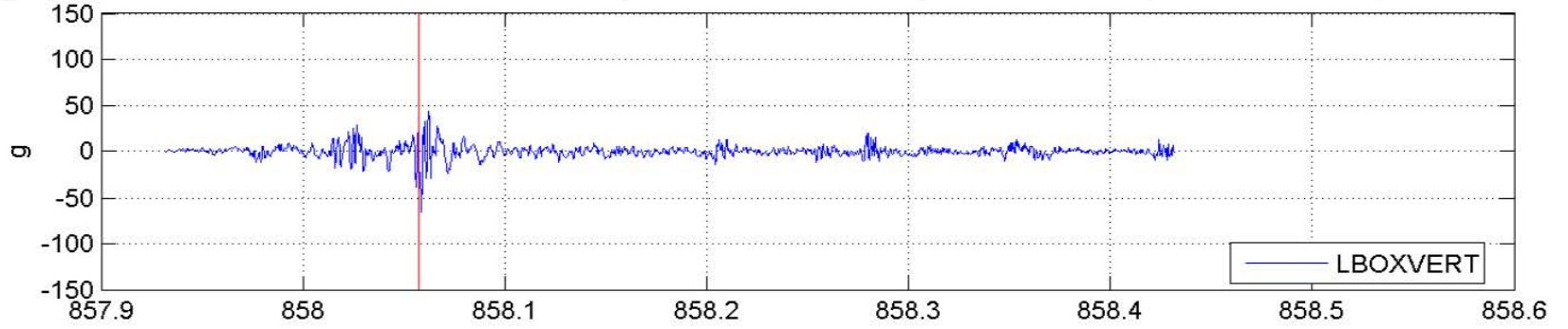

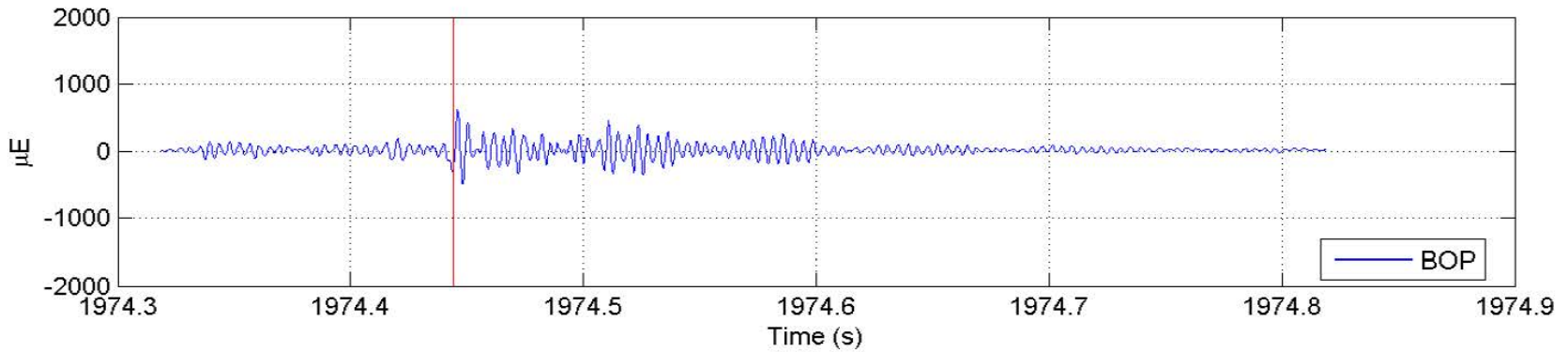
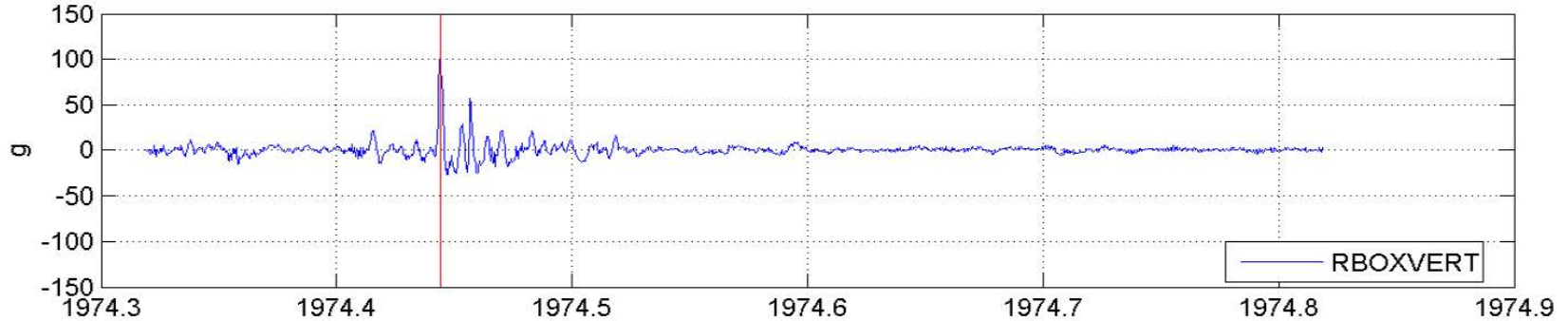
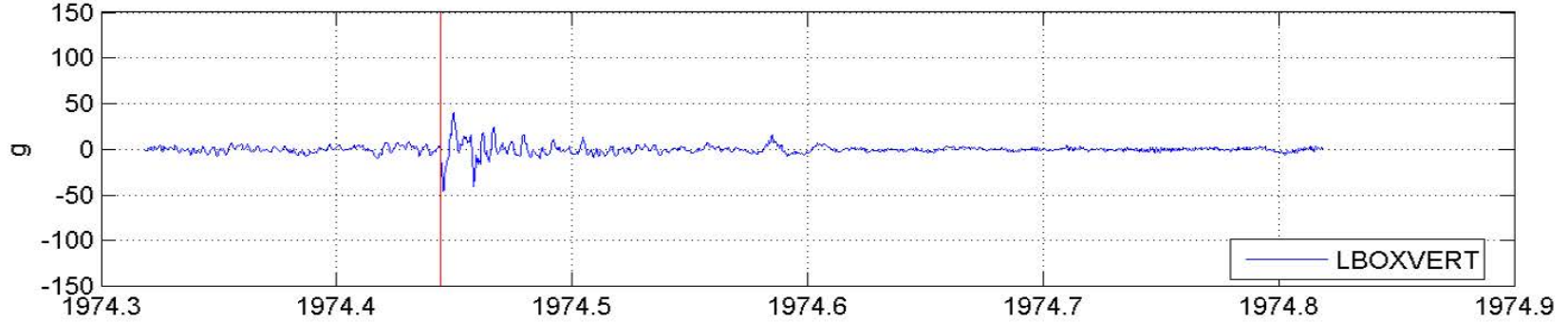

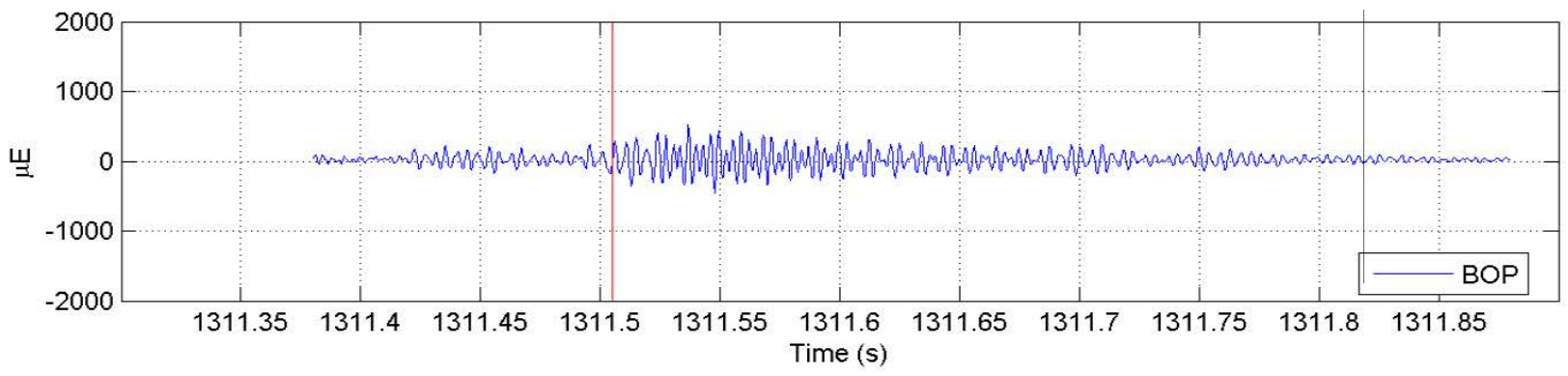
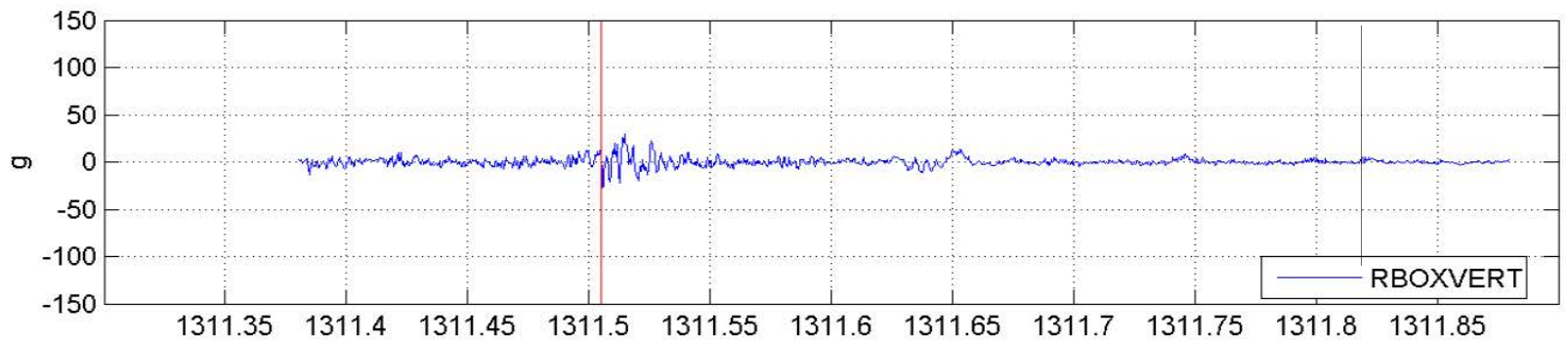
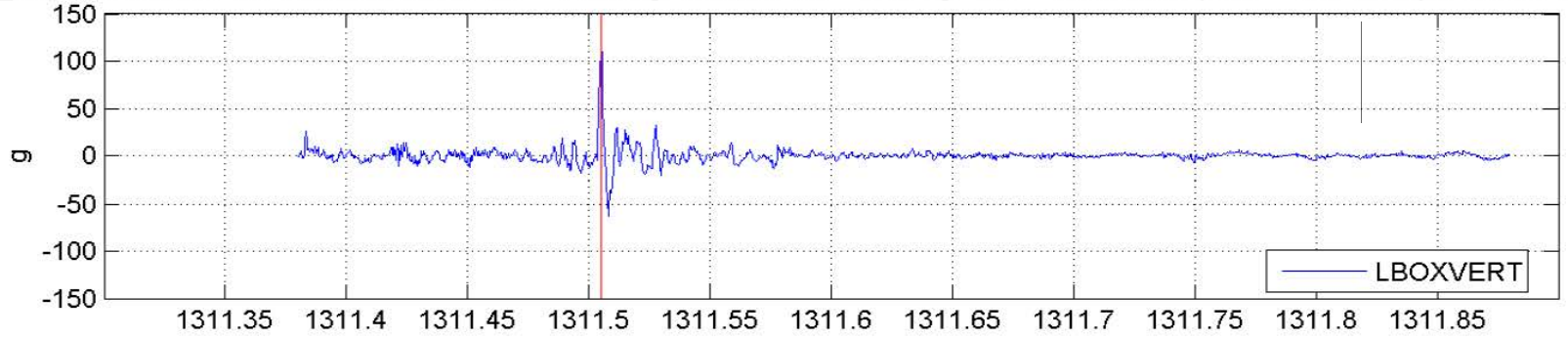

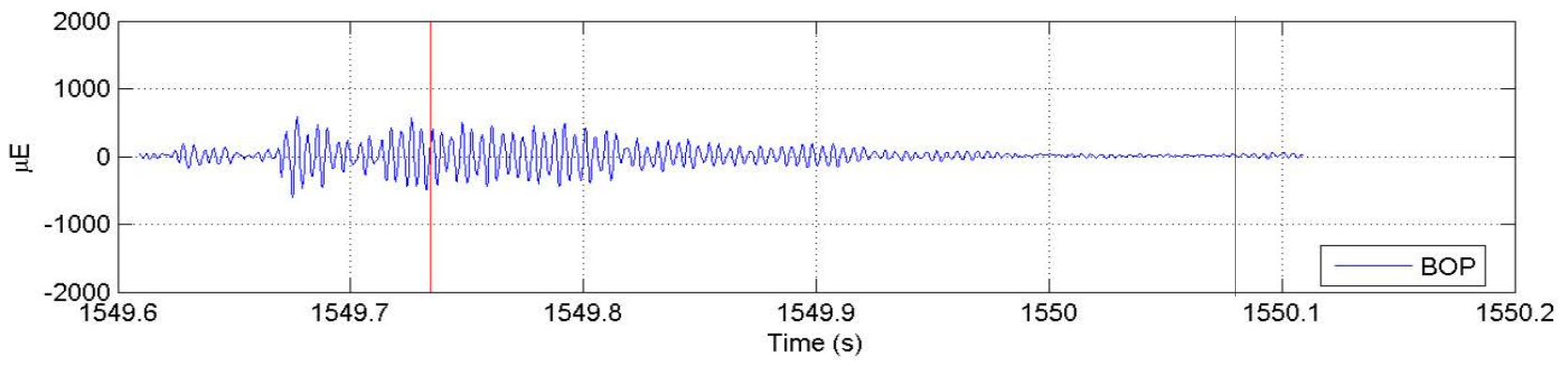
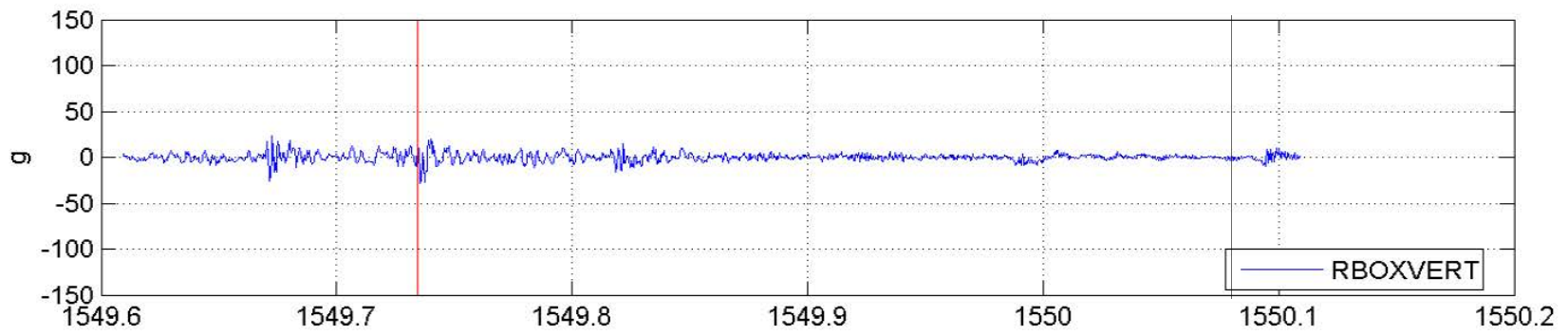
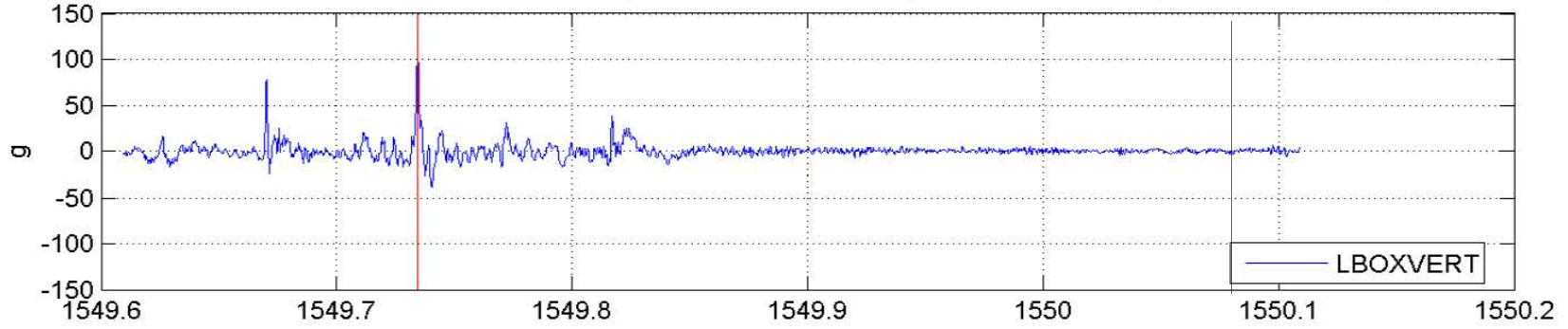

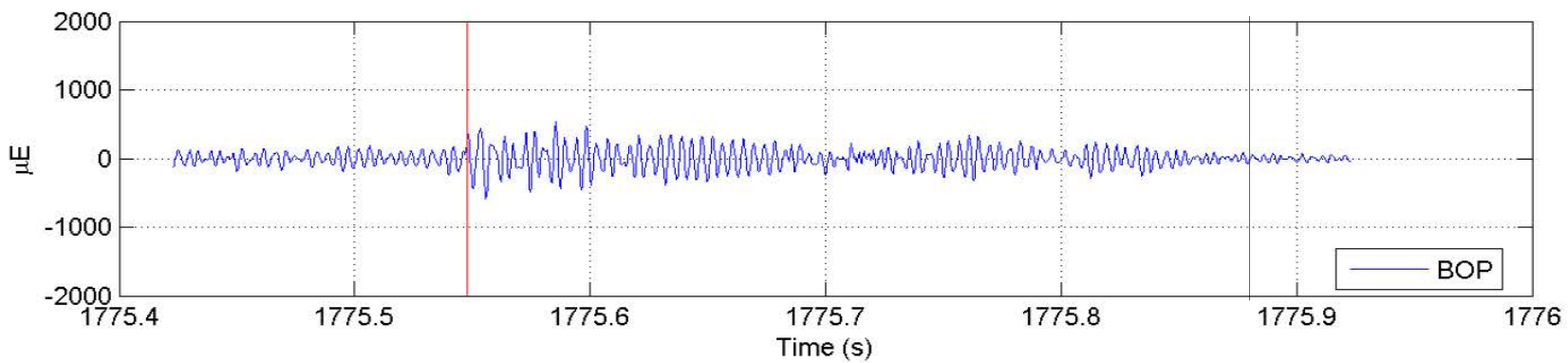
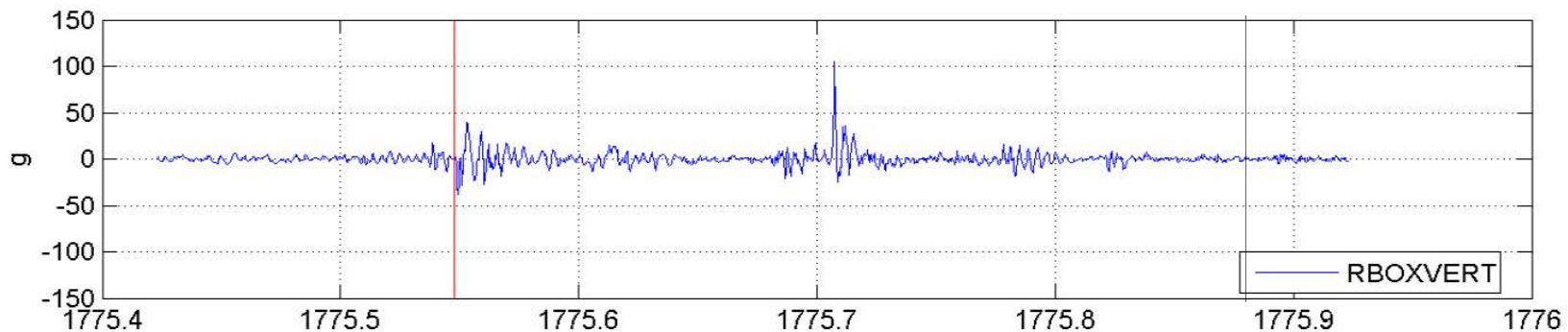
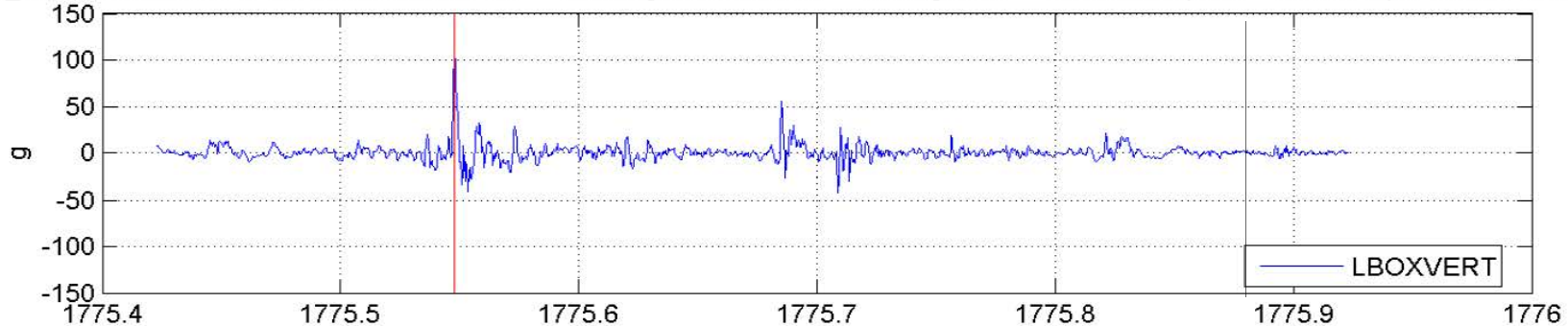

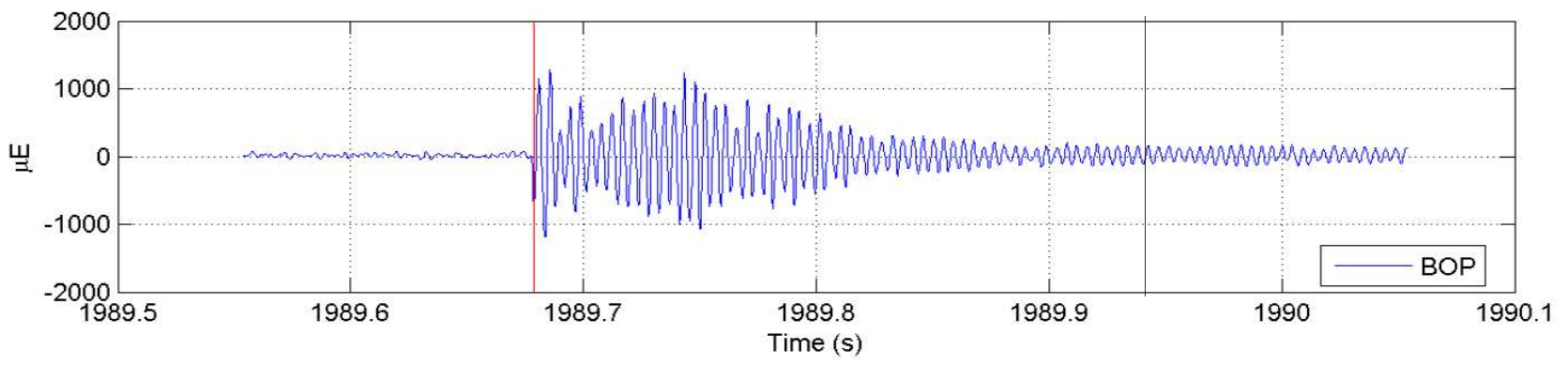
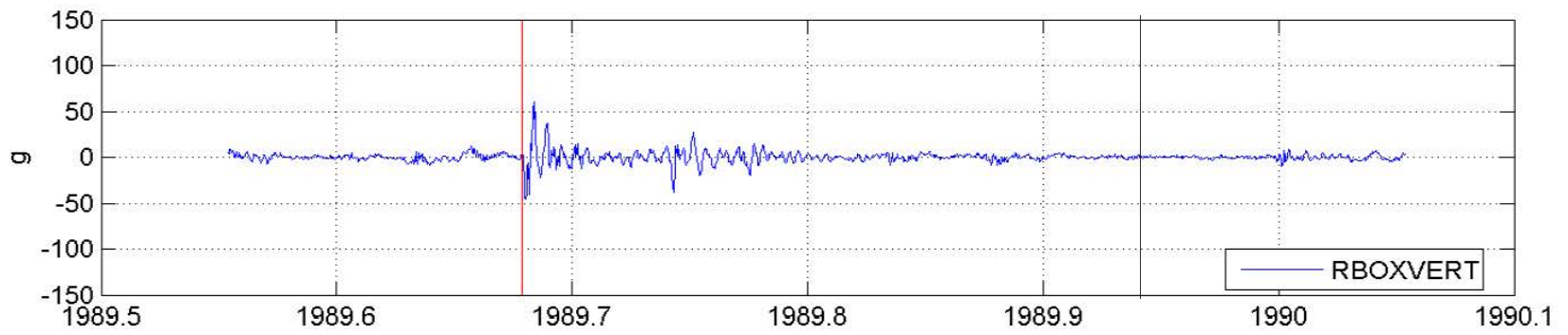
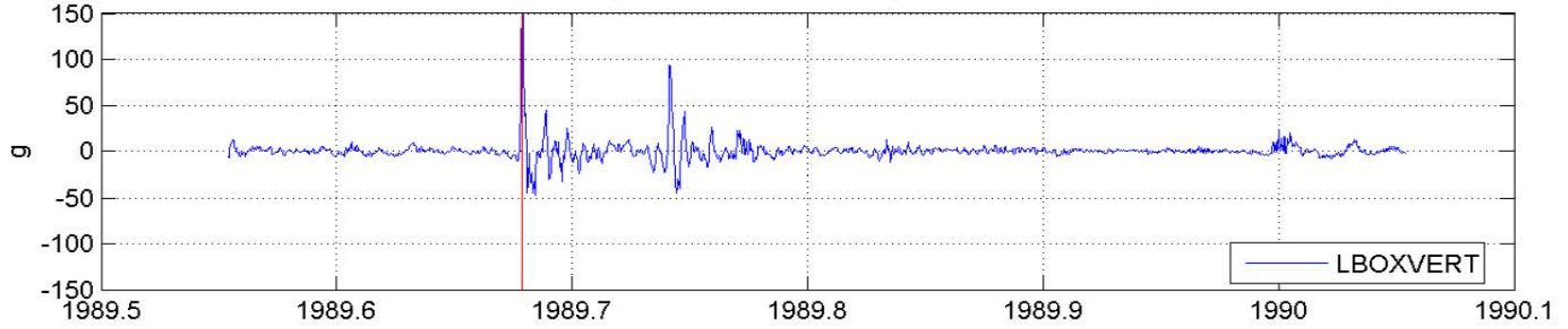

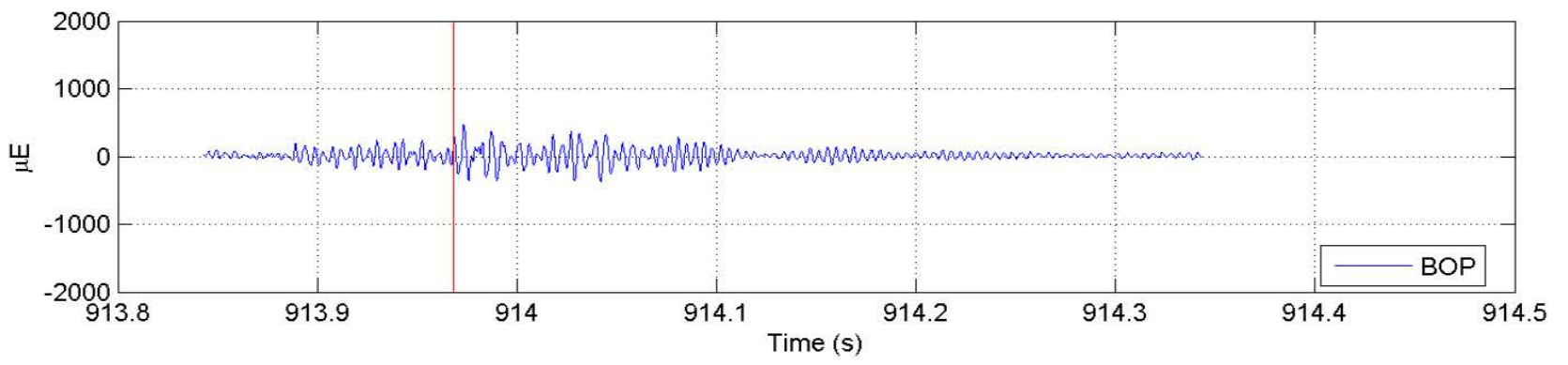
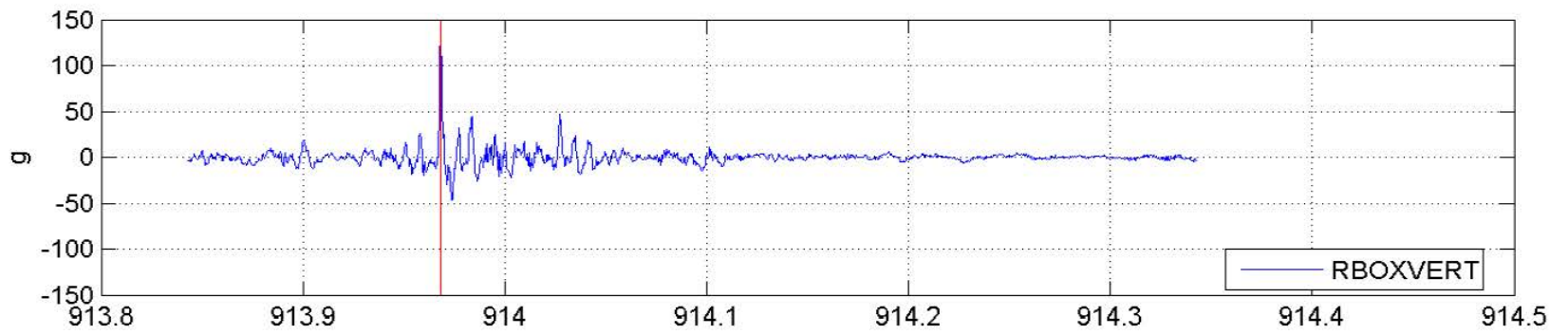
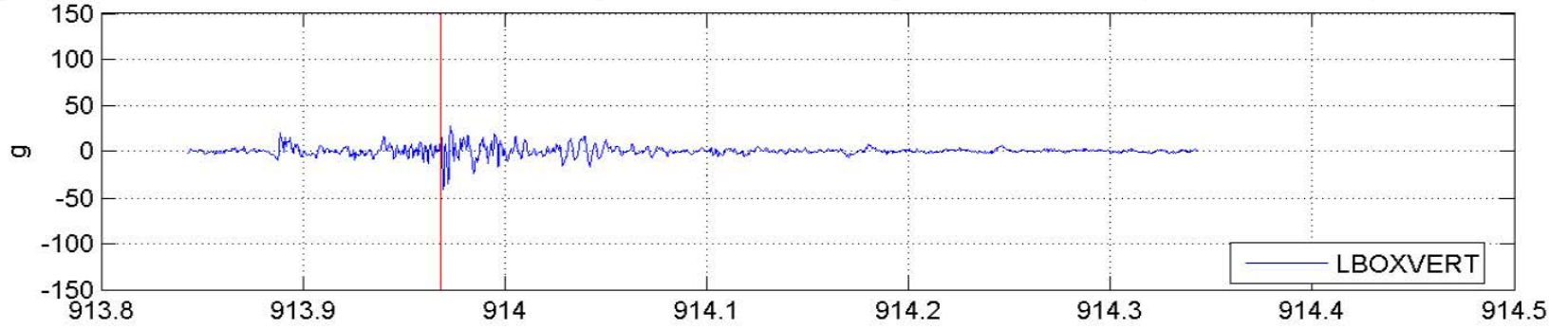

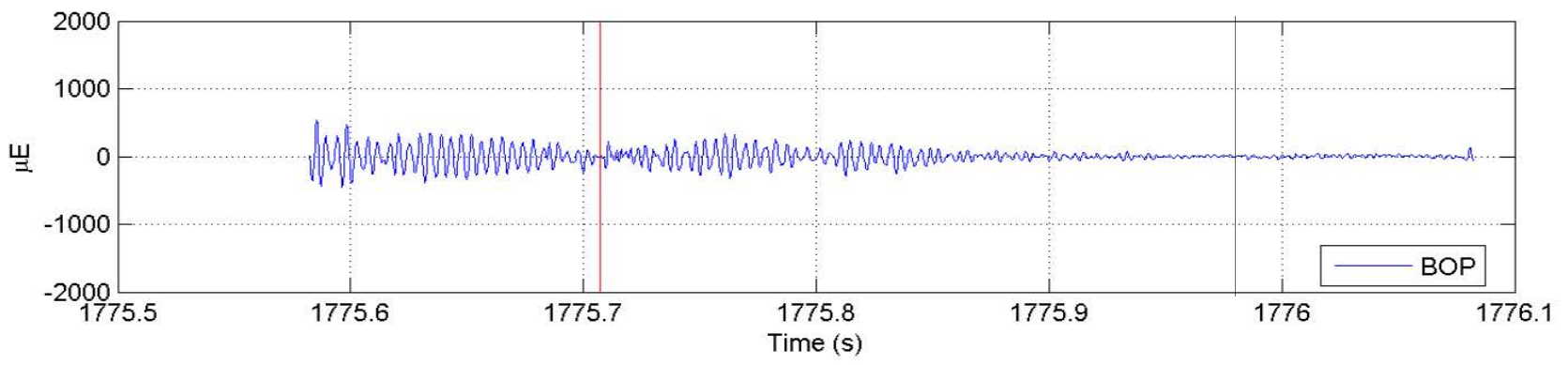
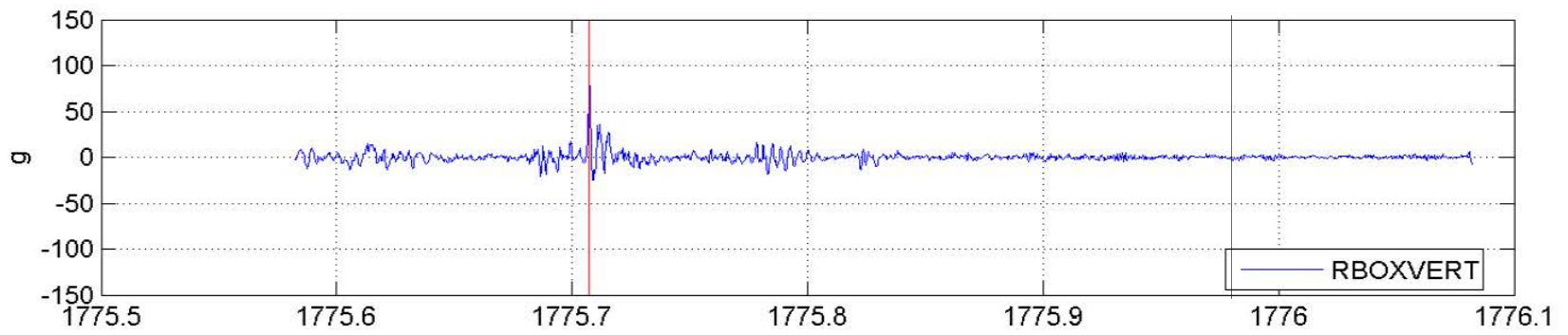
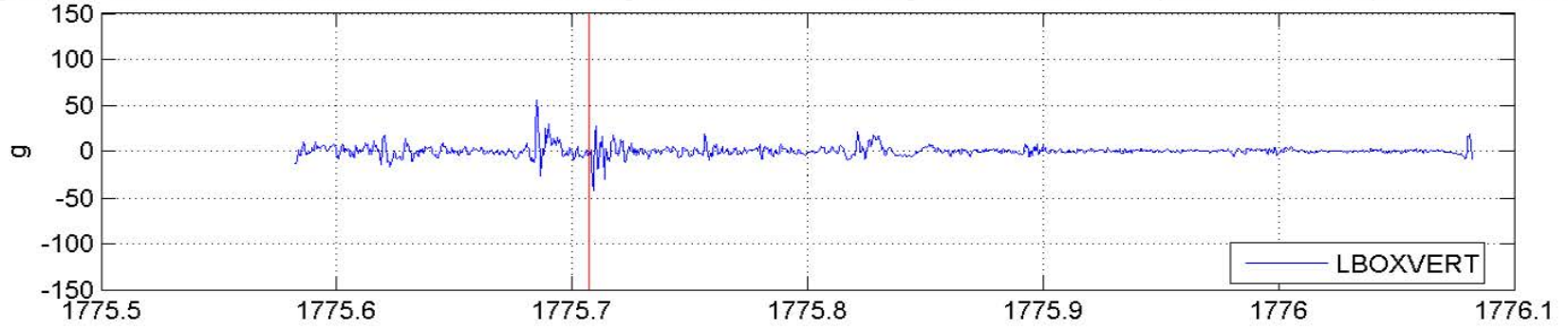

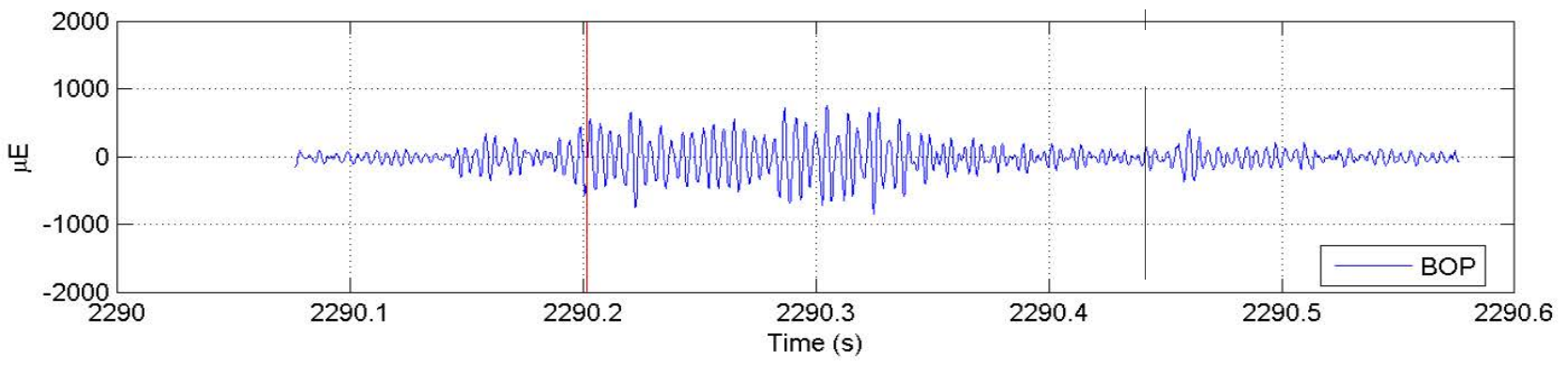
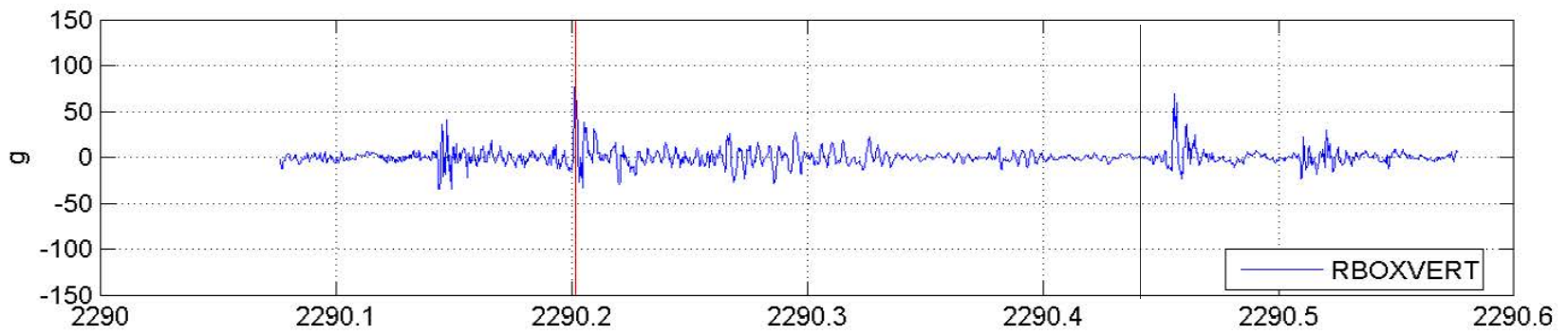
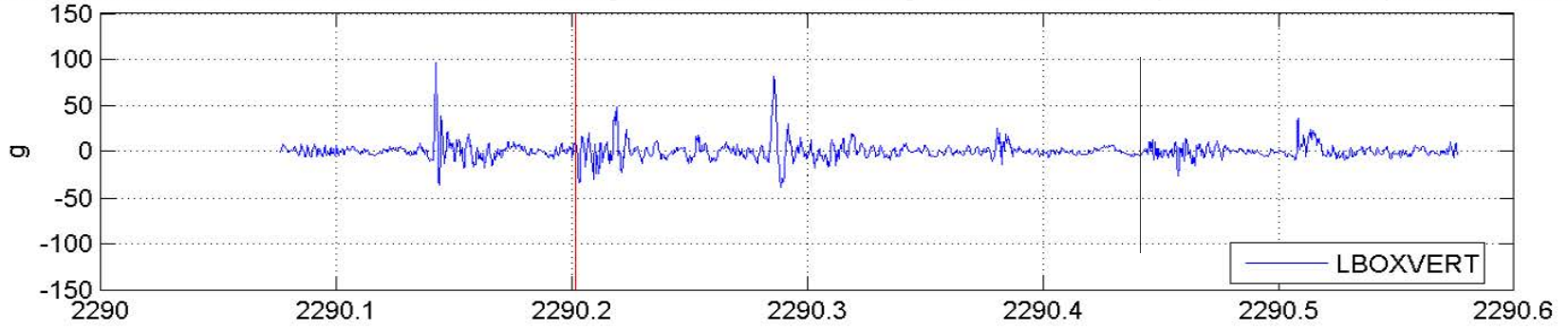

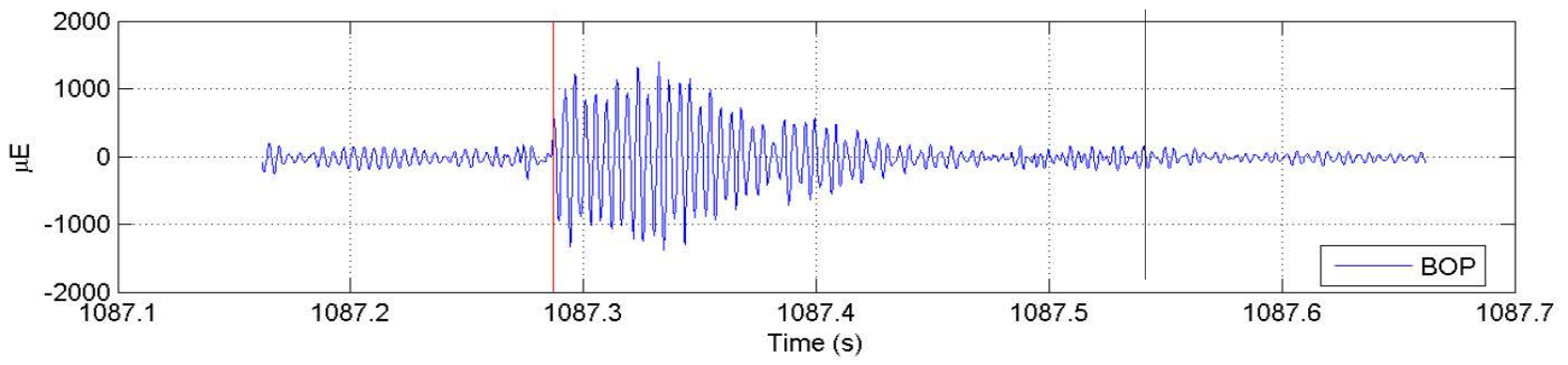
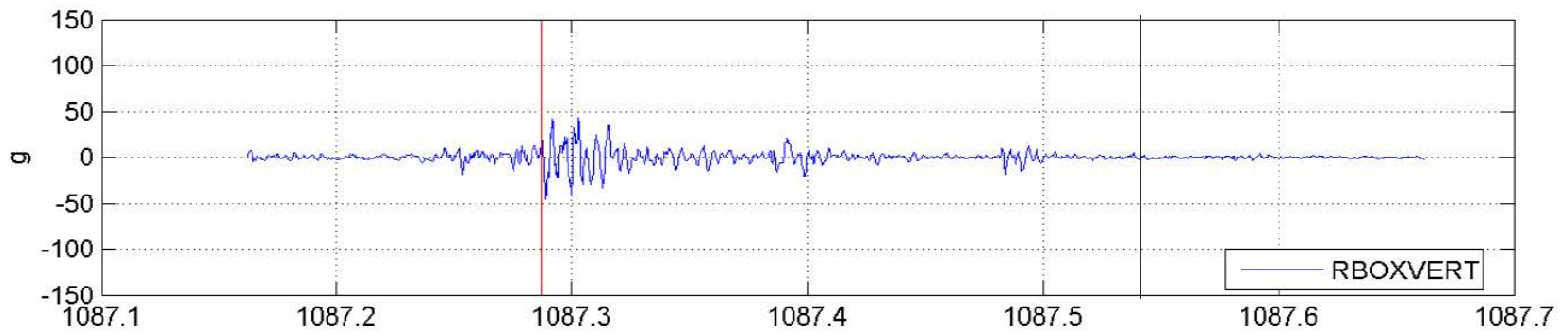
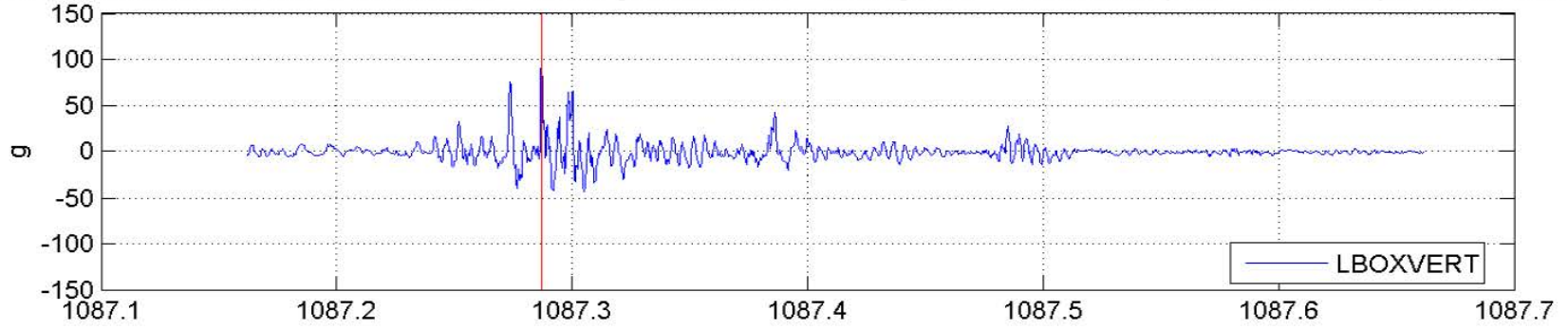

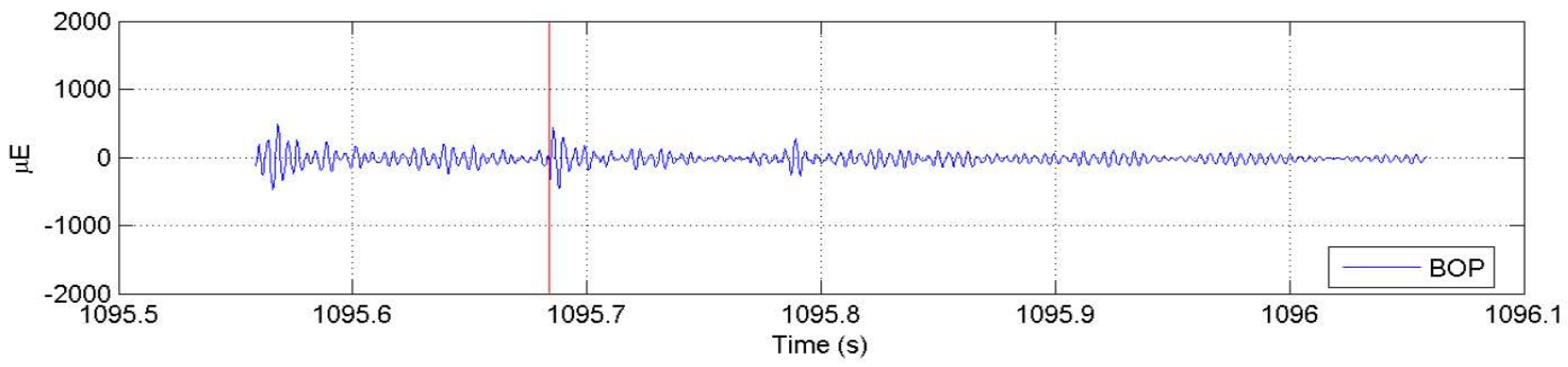
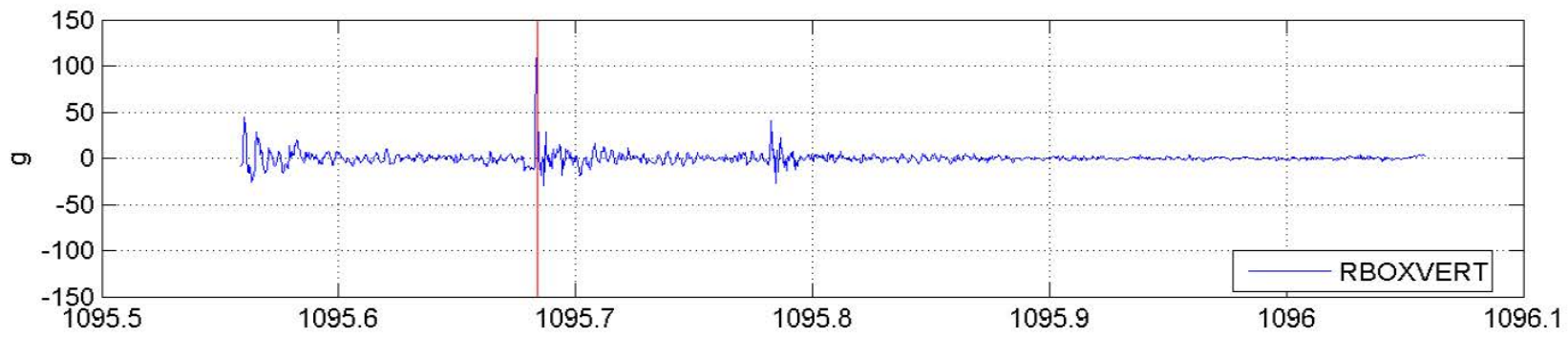
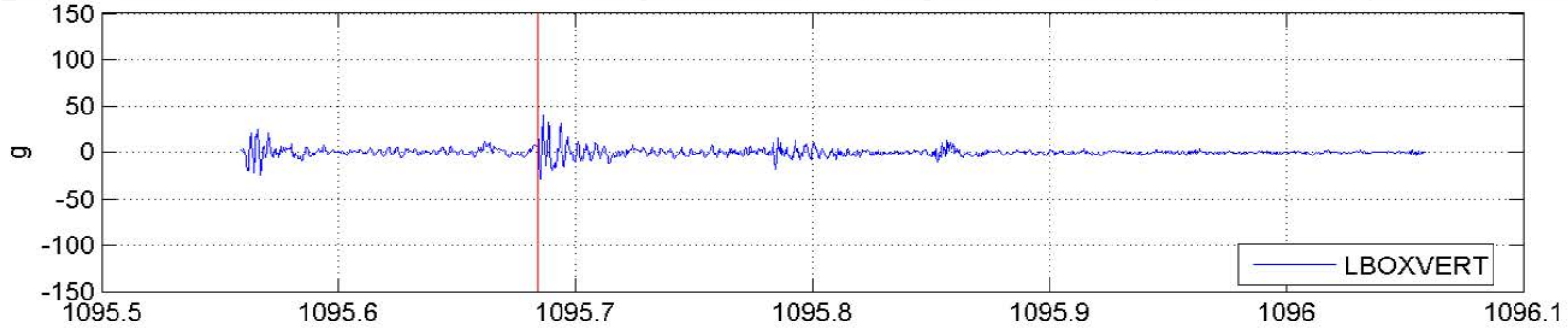

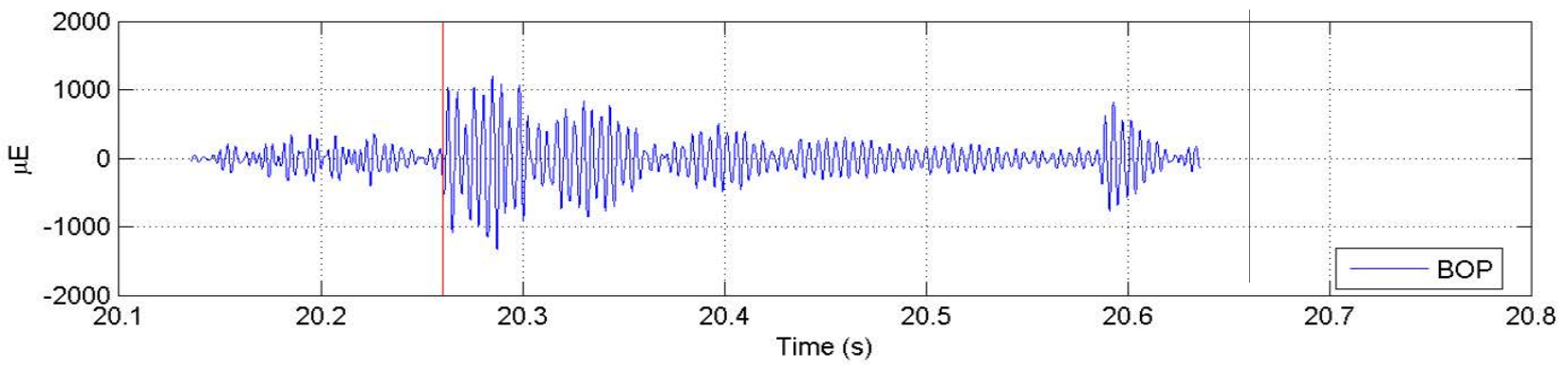
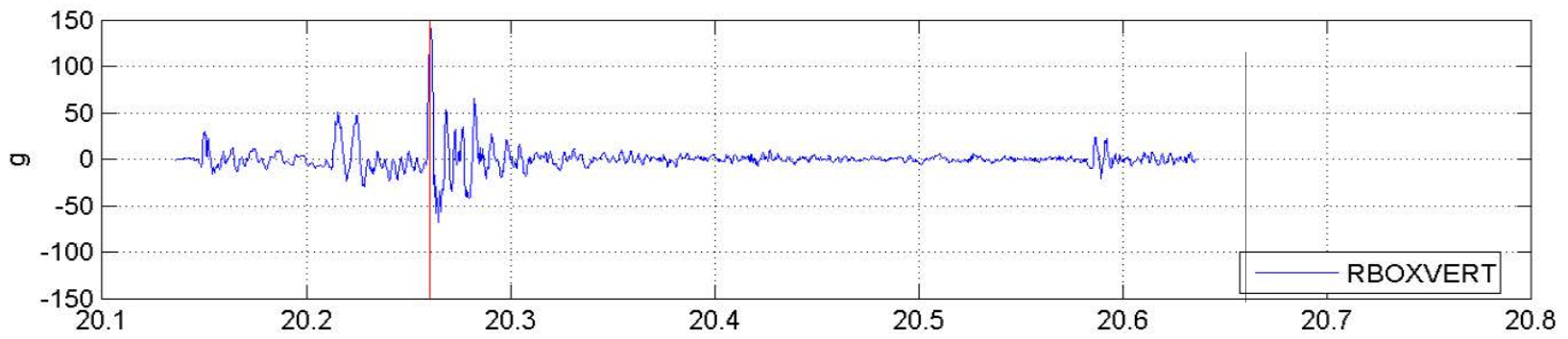
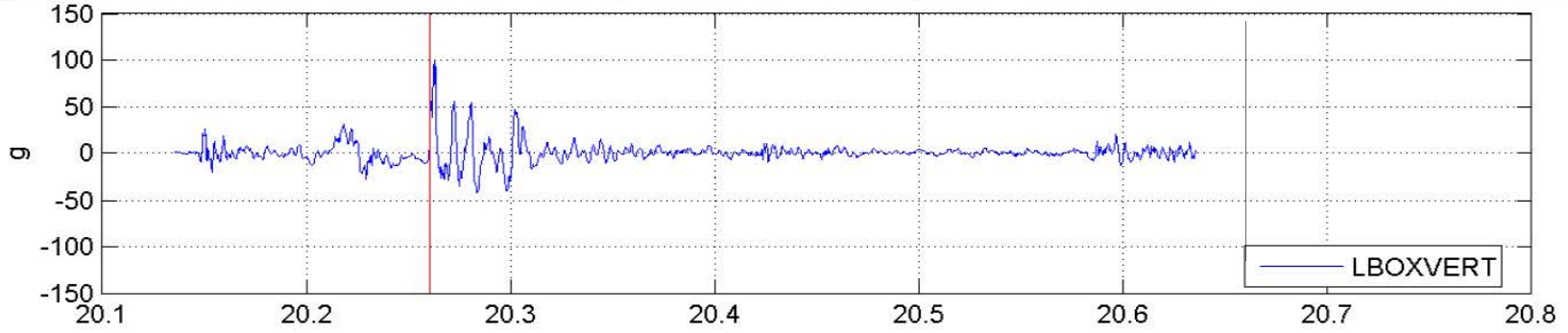

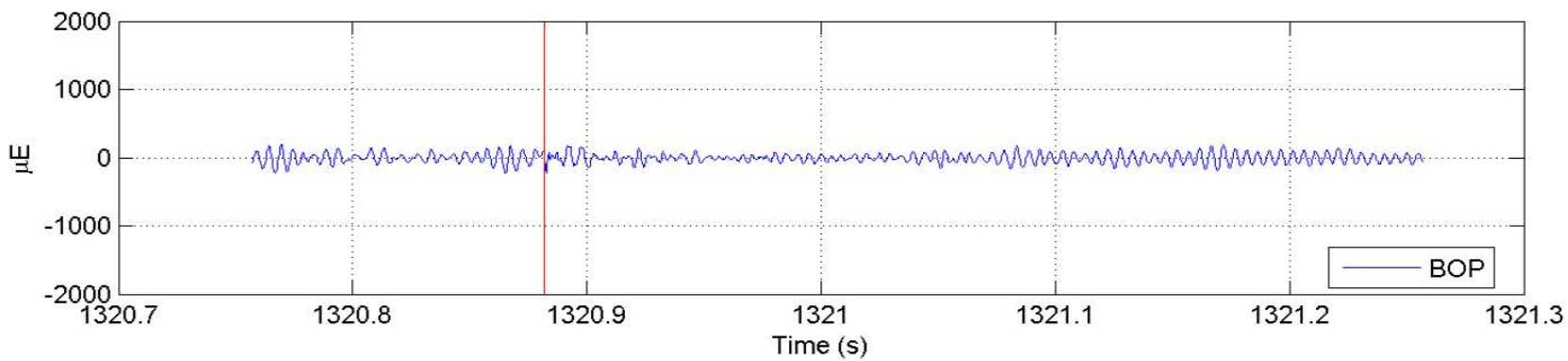
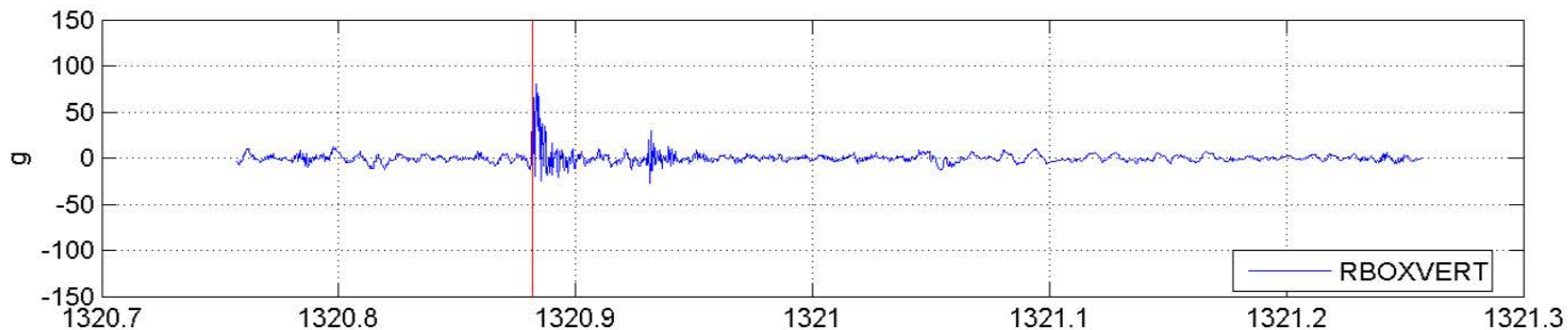
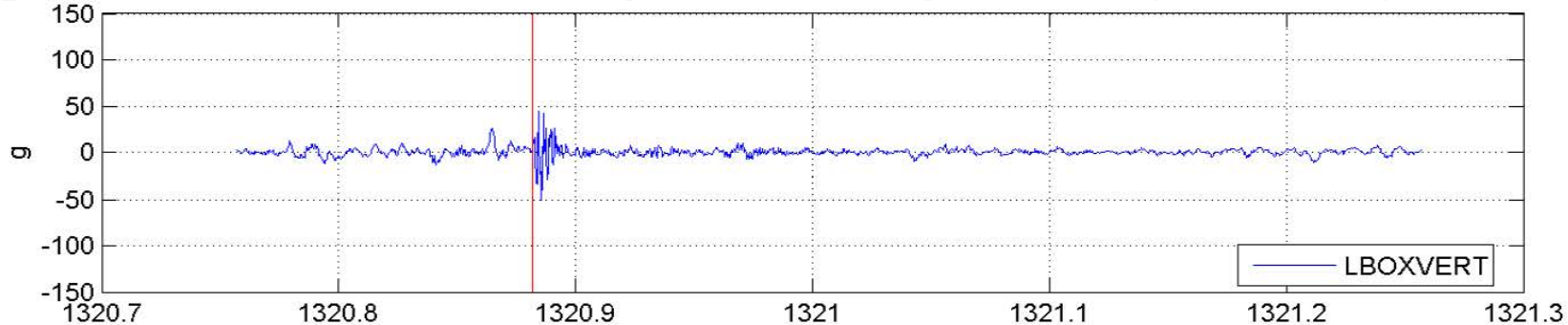

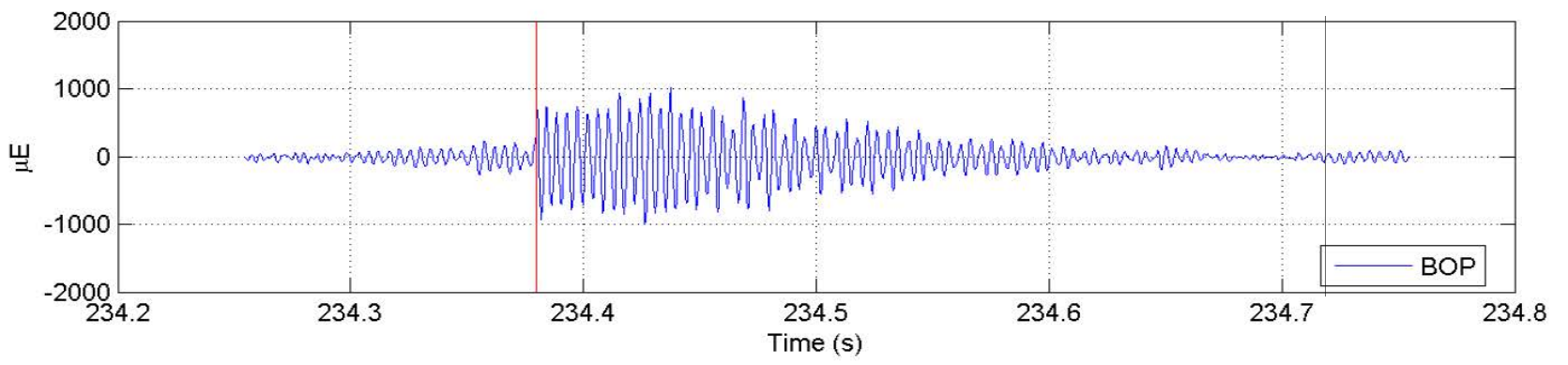
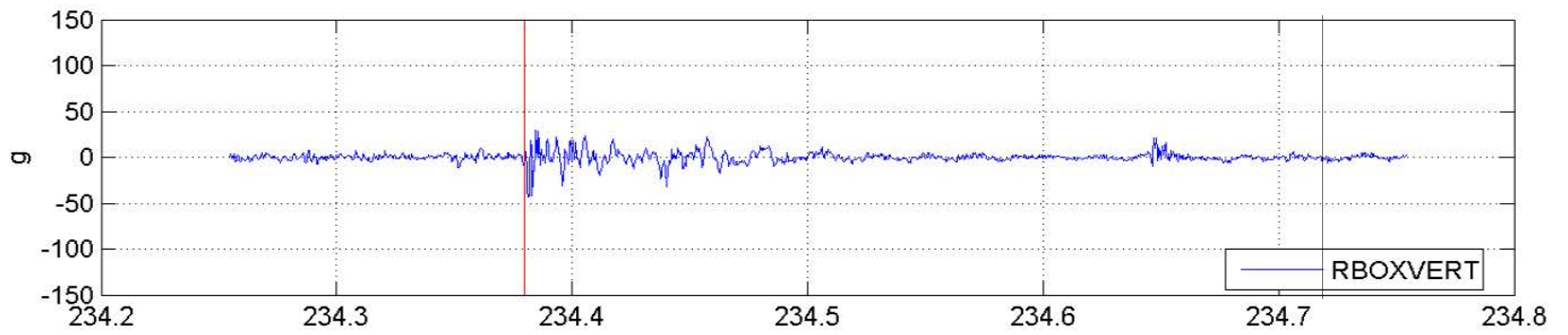
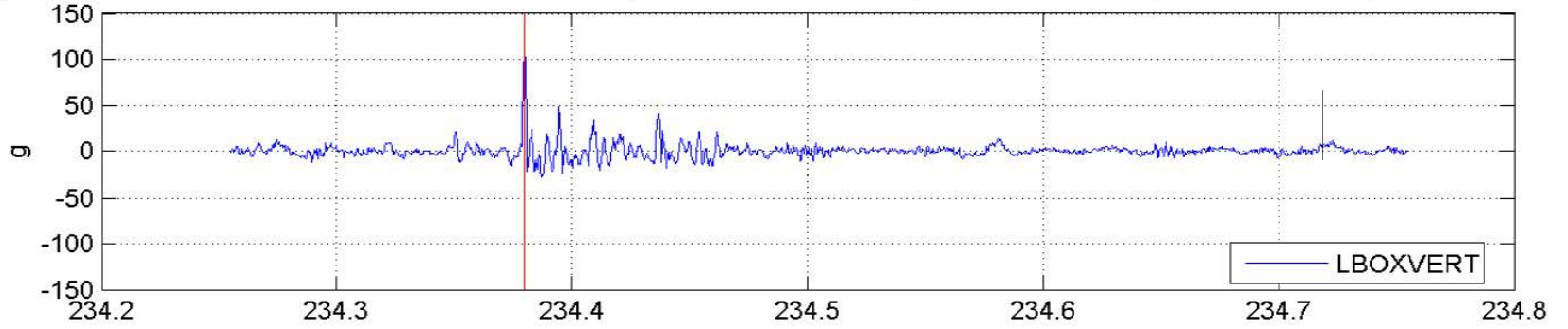

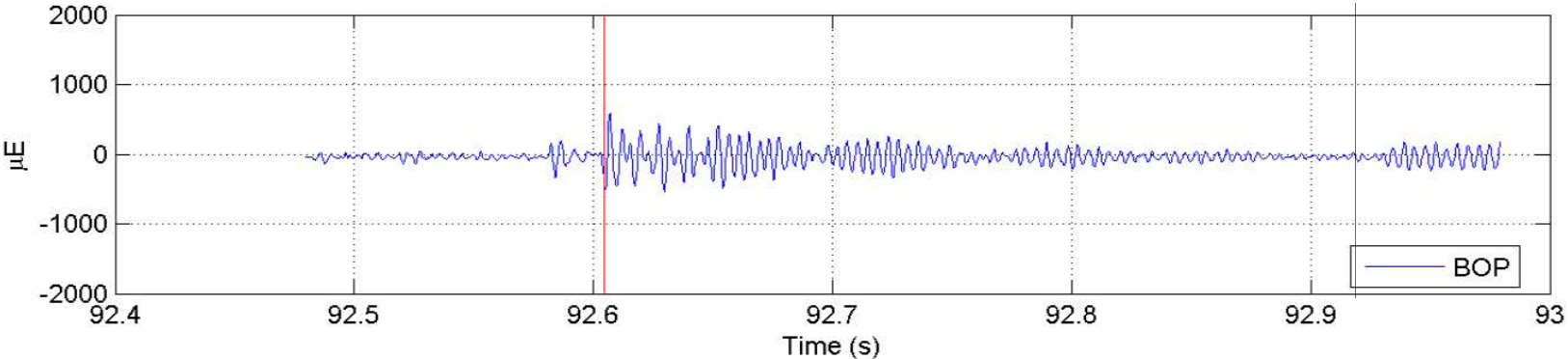
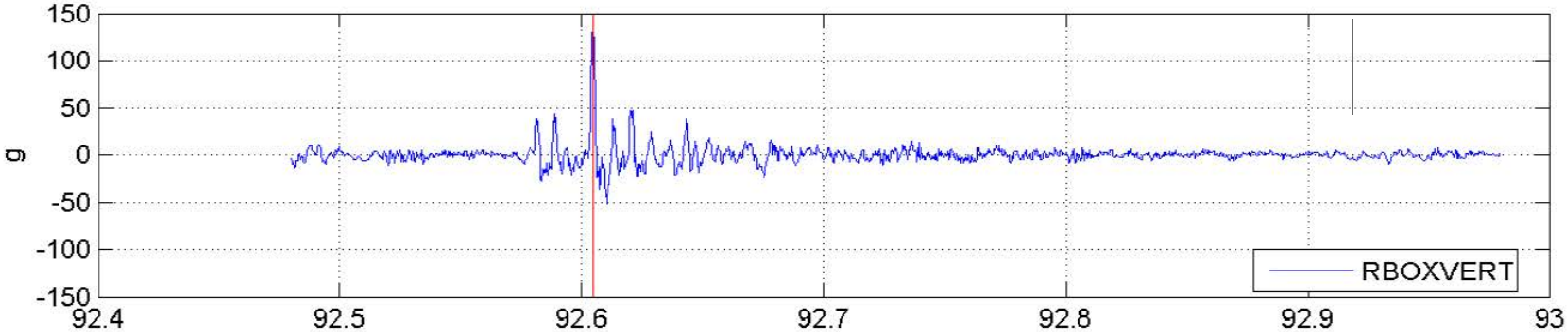
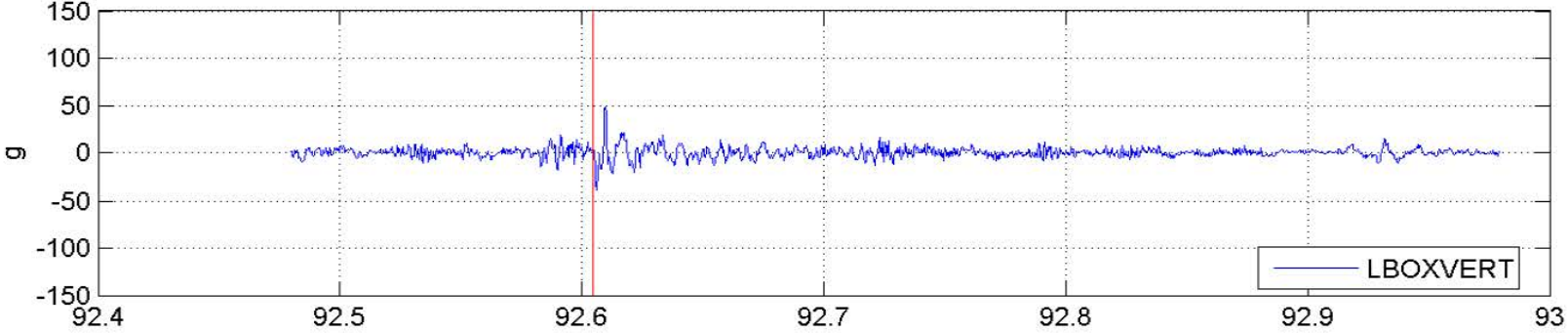

Day 4–May 27, 2005

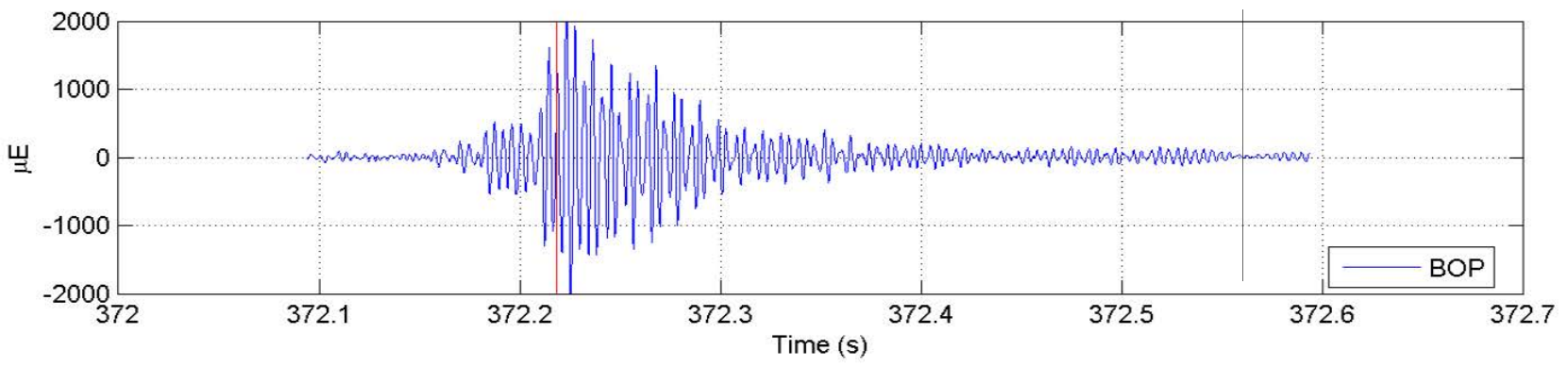
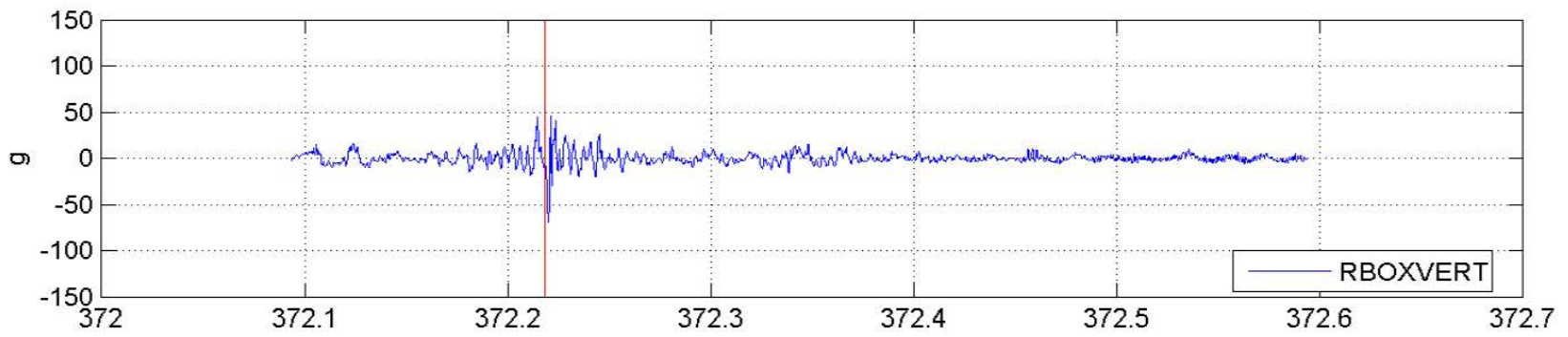
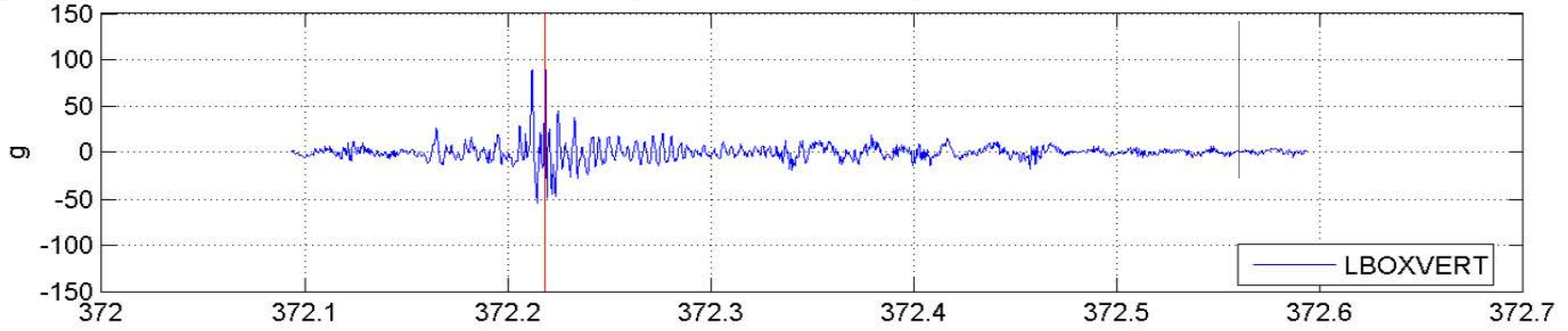

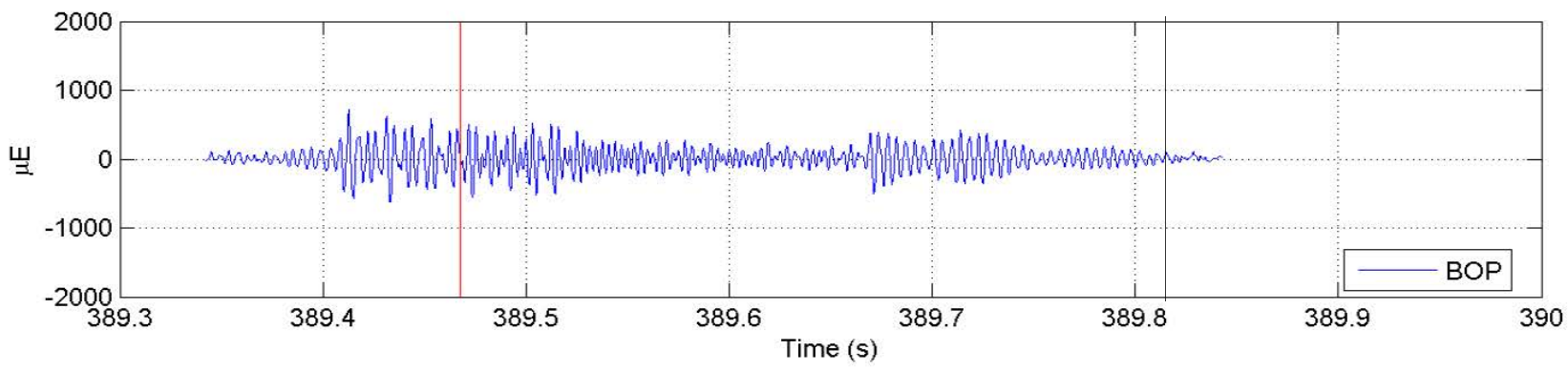
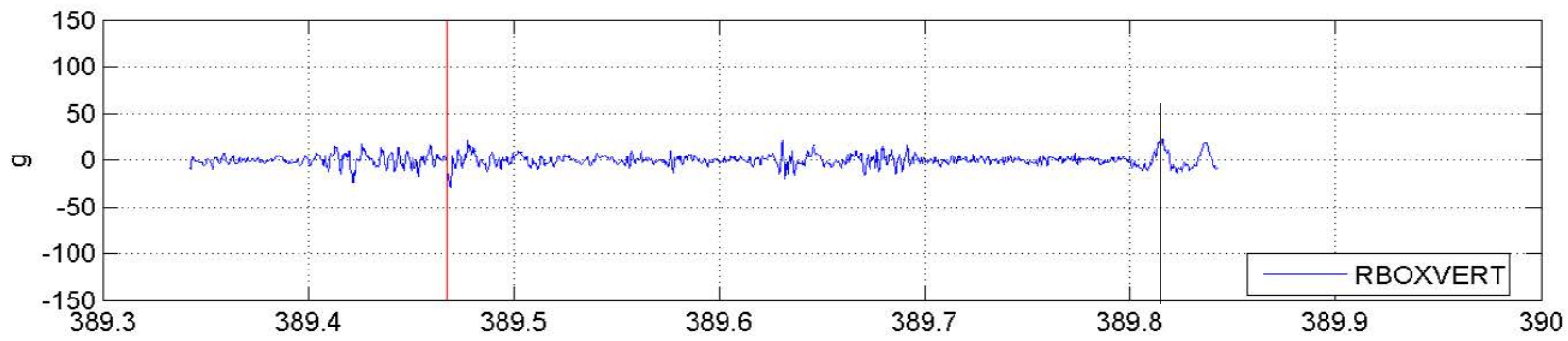
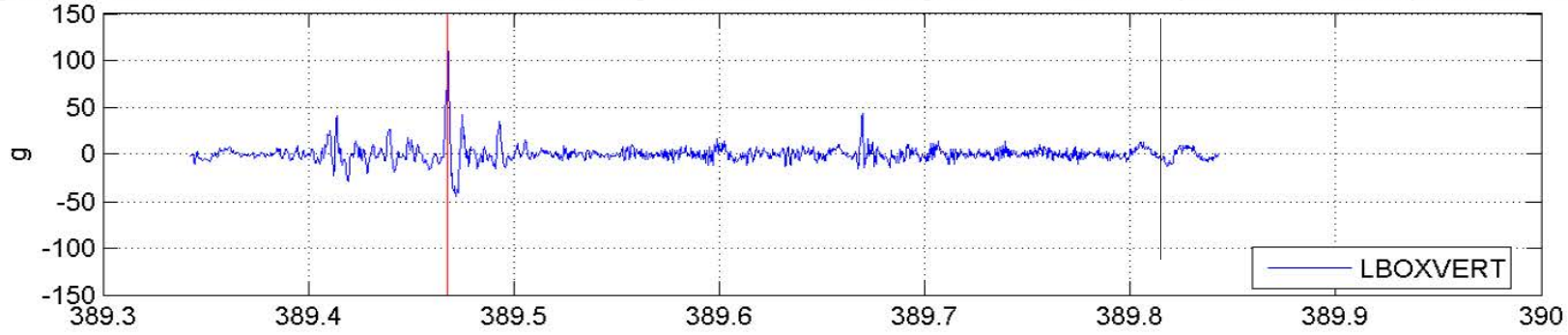

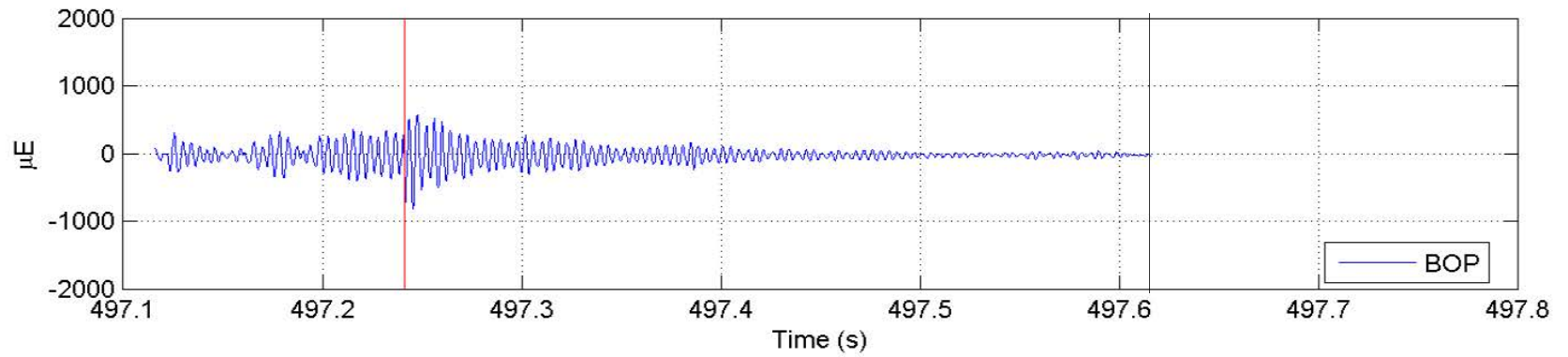
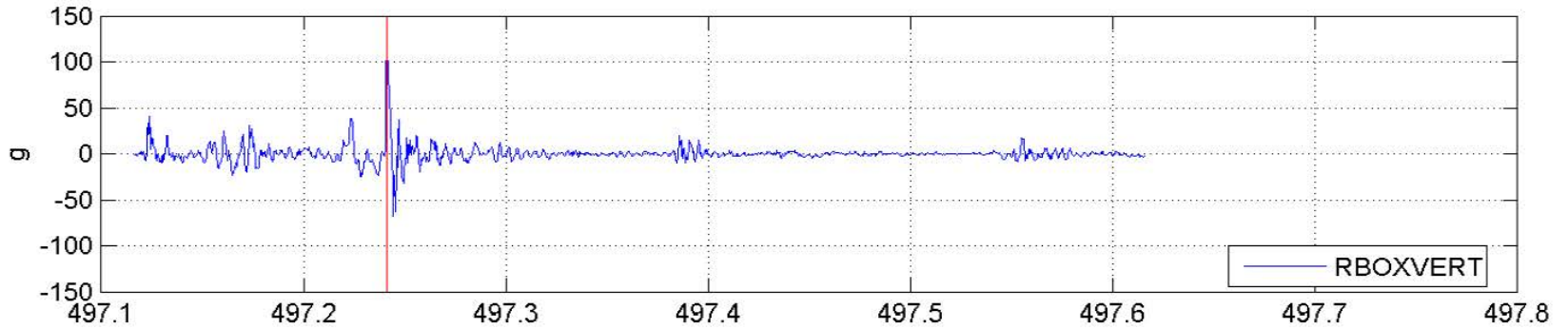
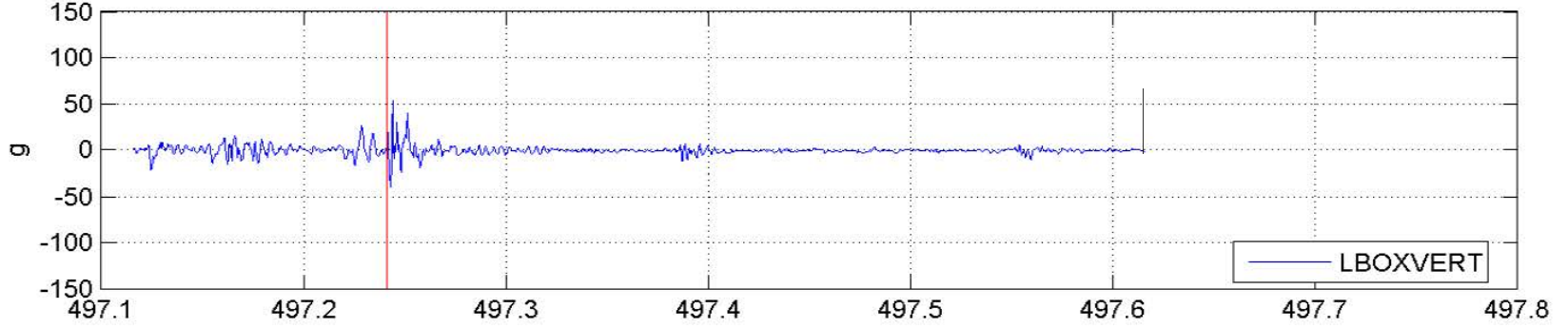

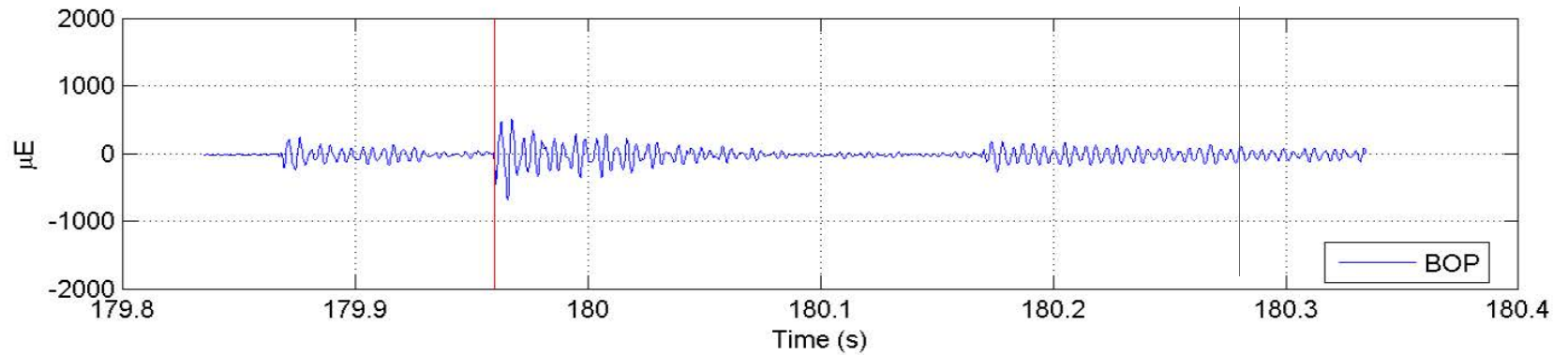
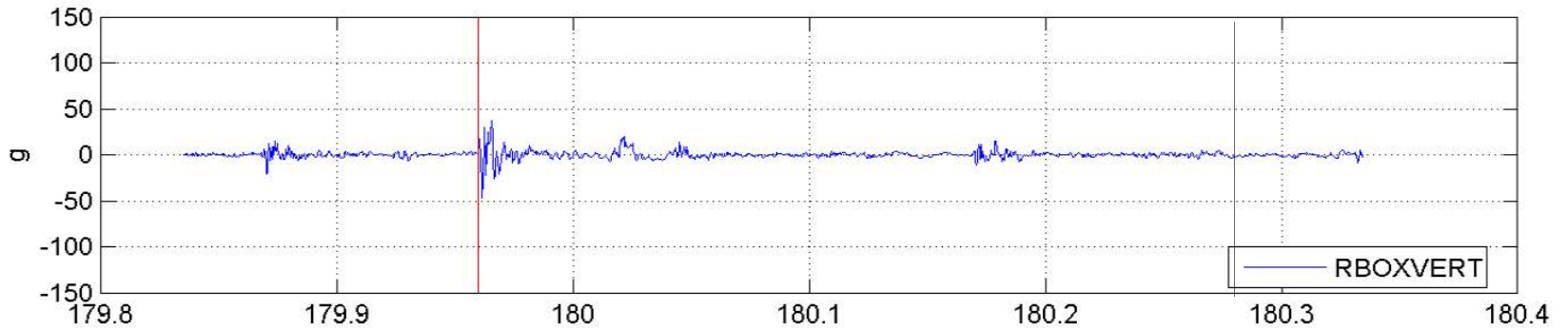
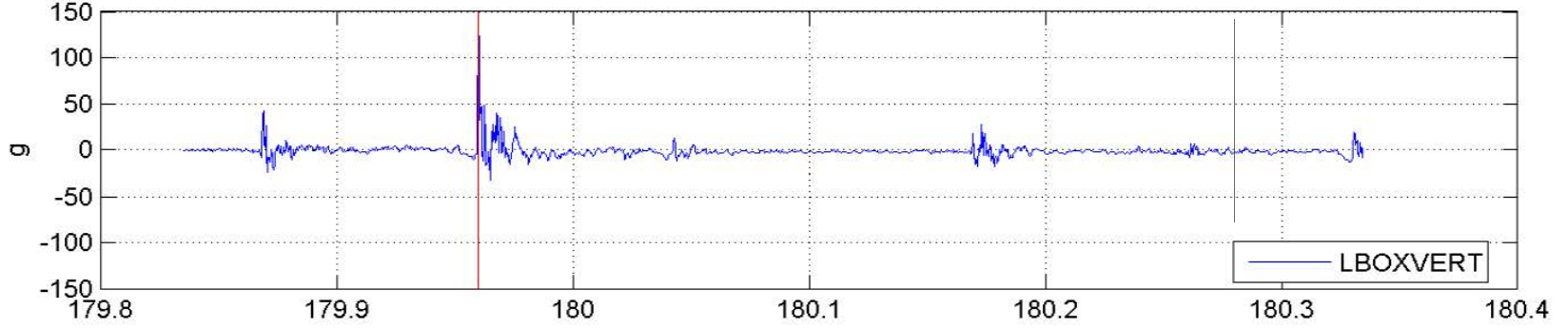

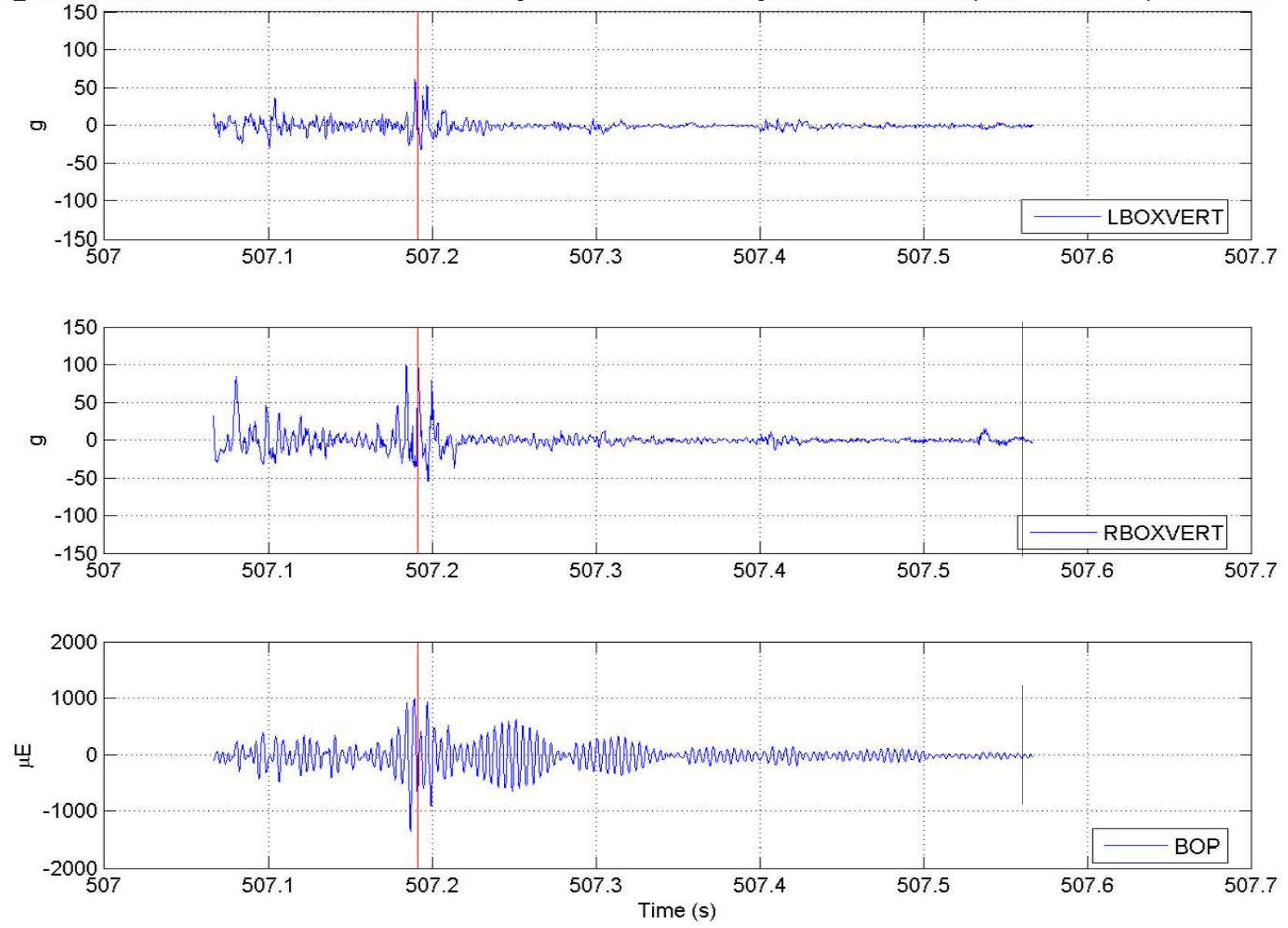

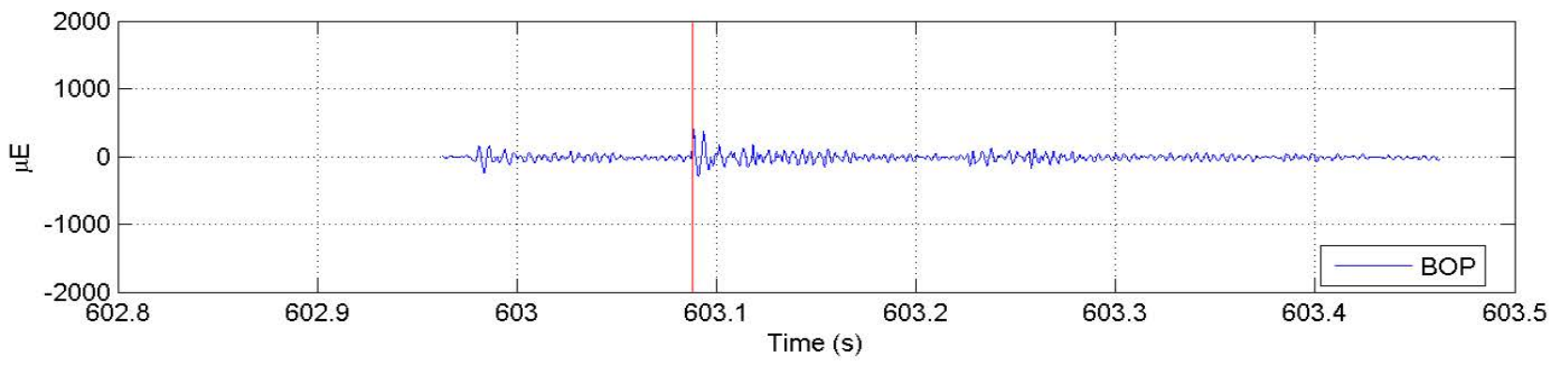
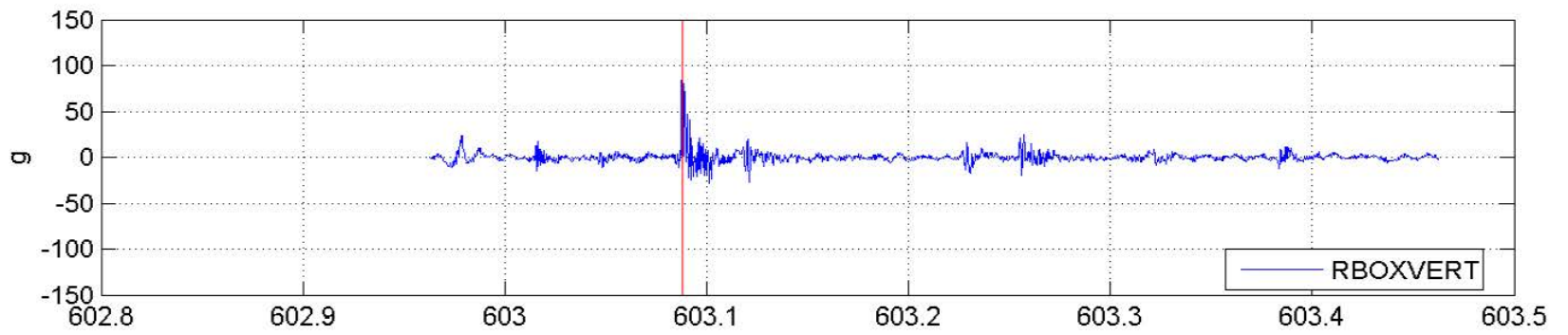
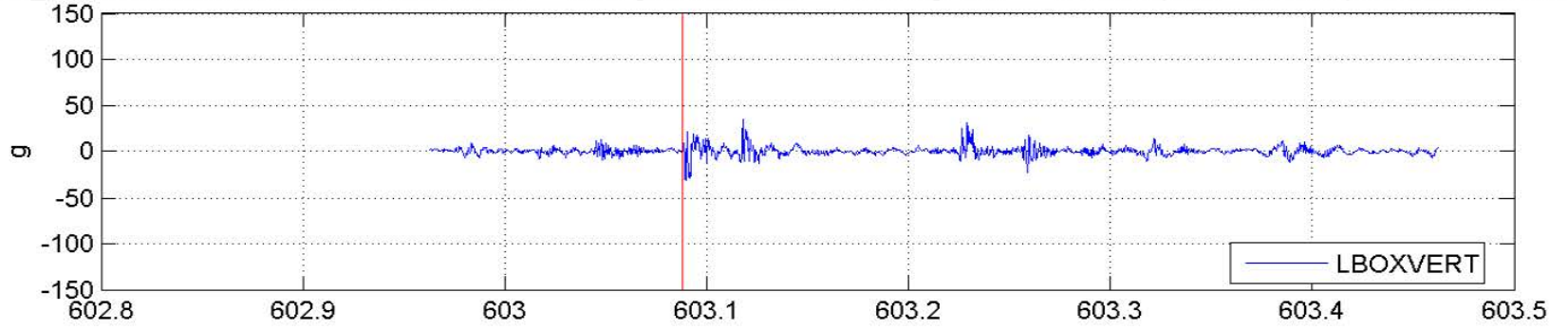

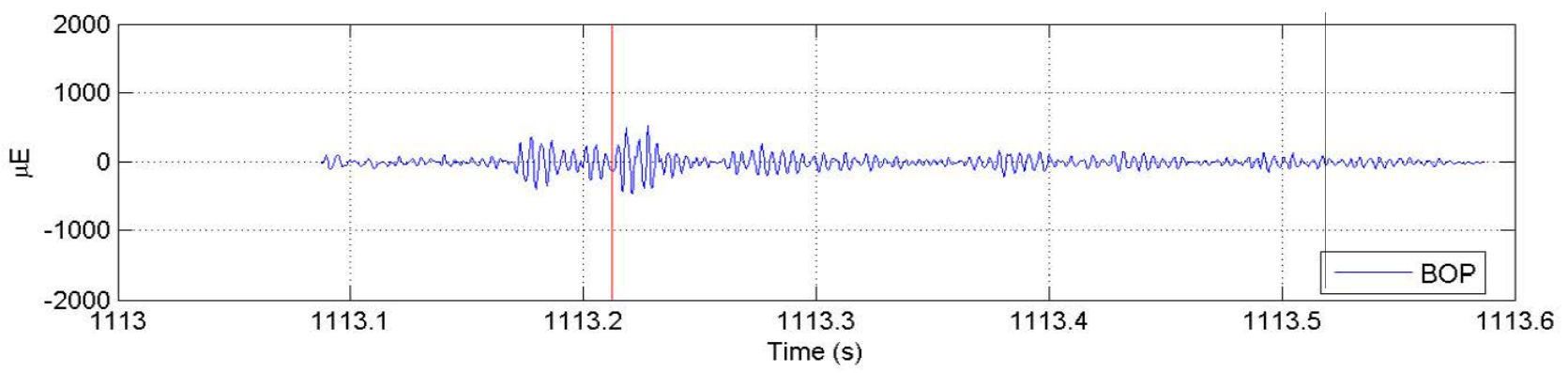
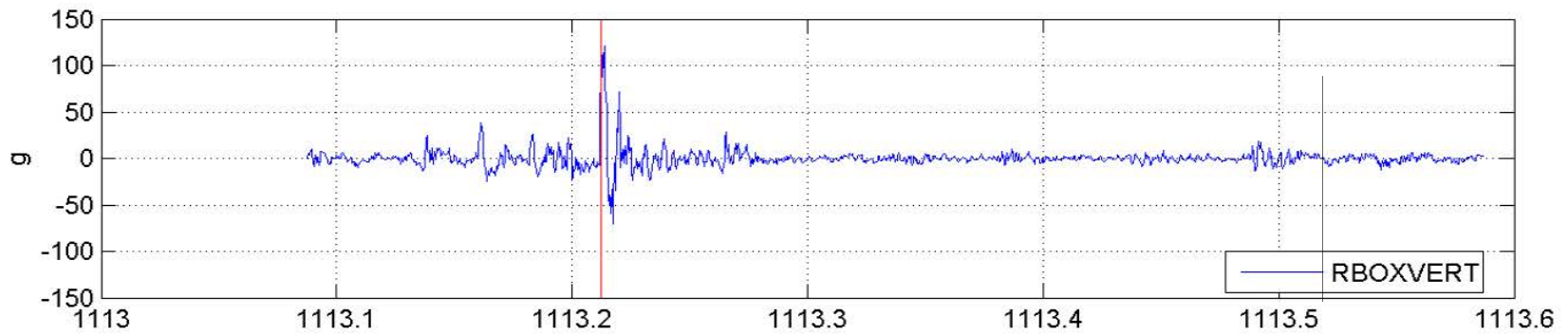
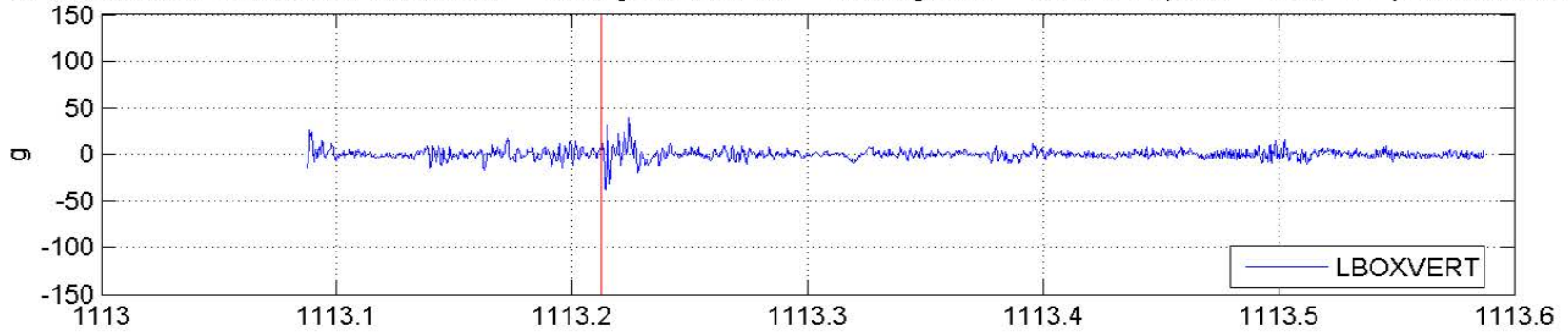

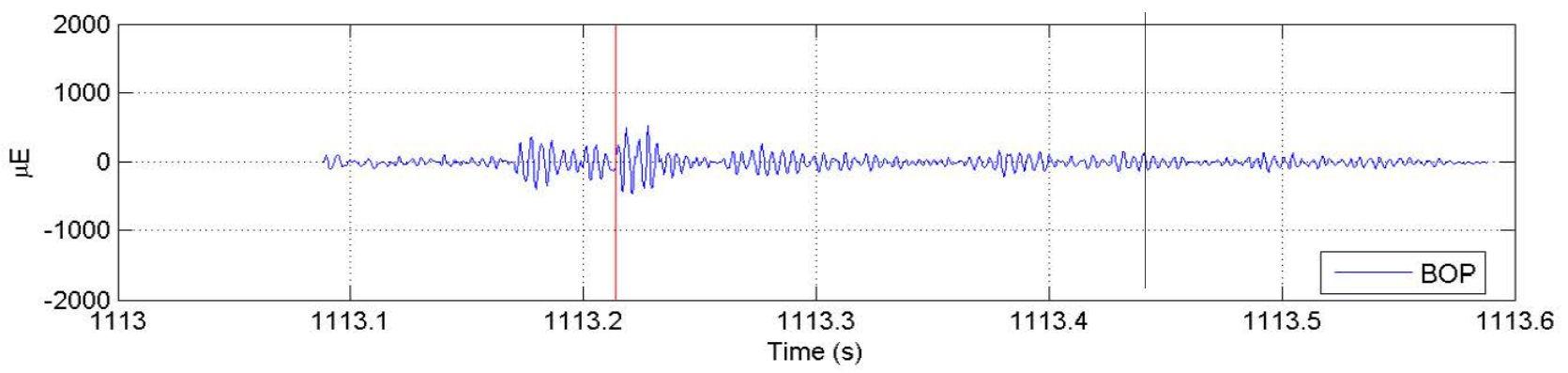
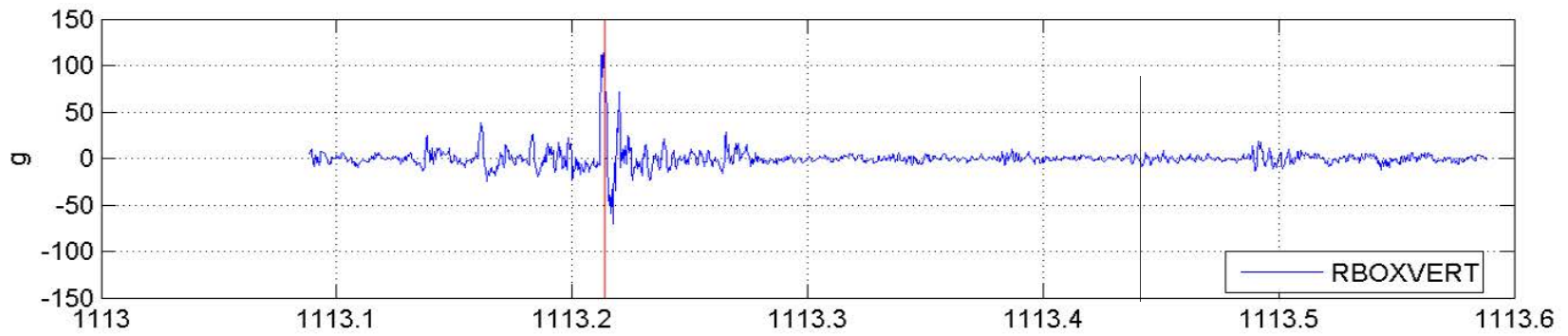
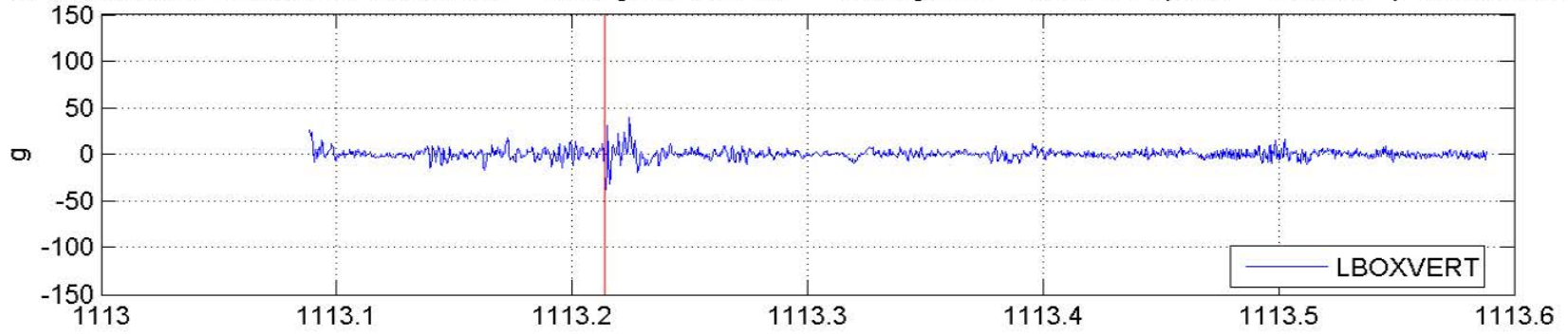

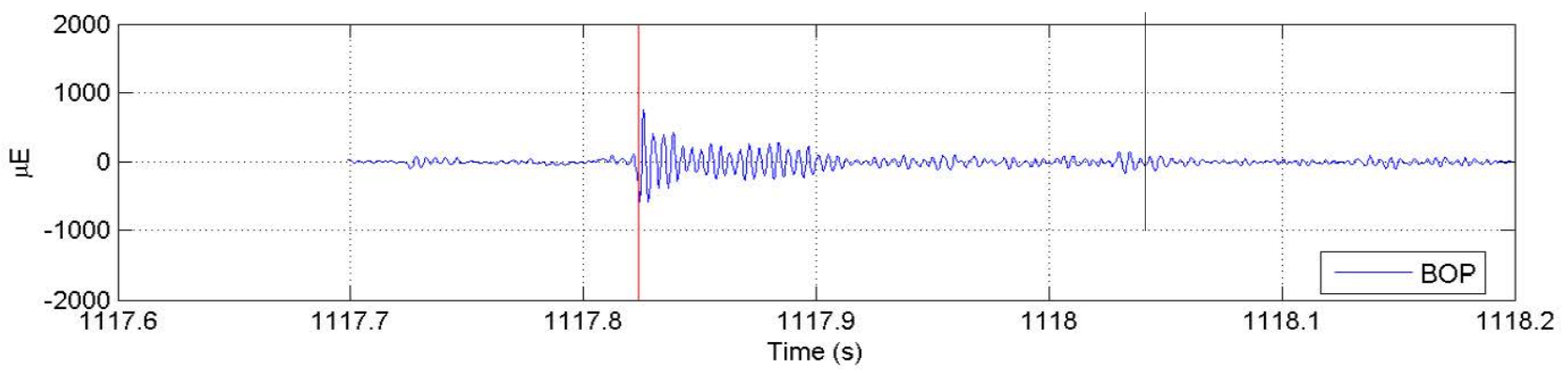
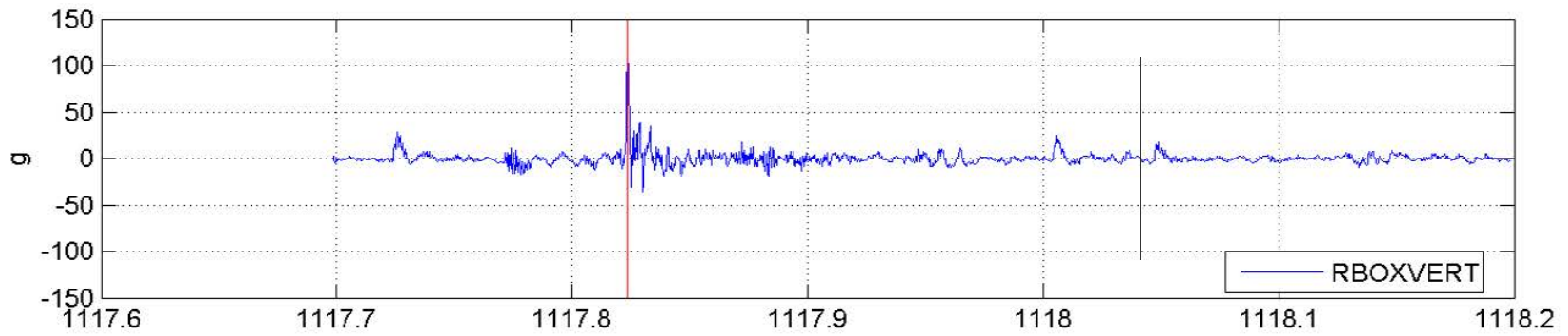
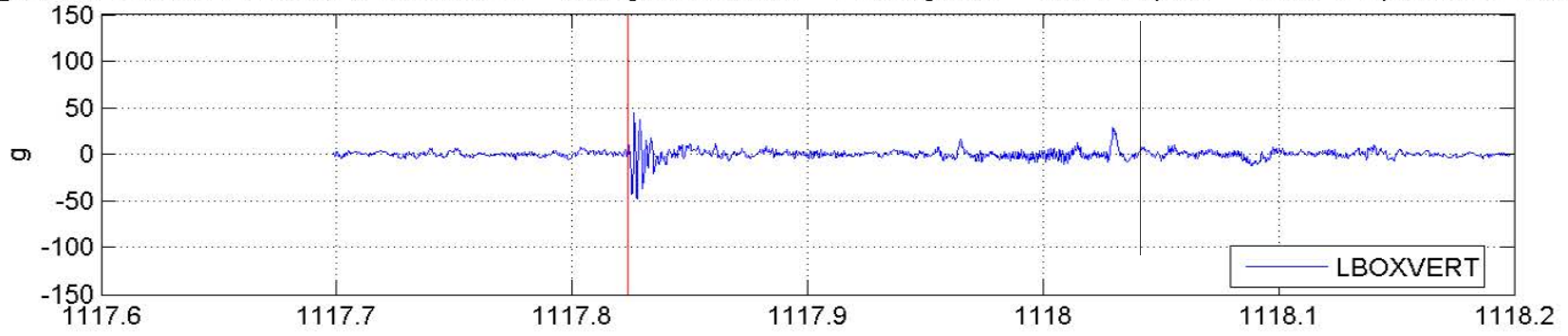

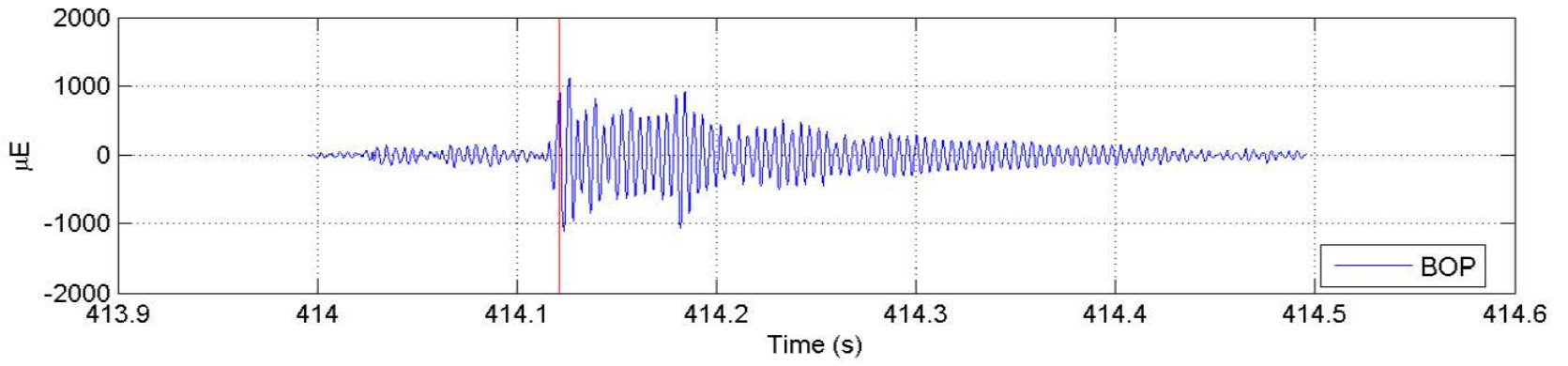
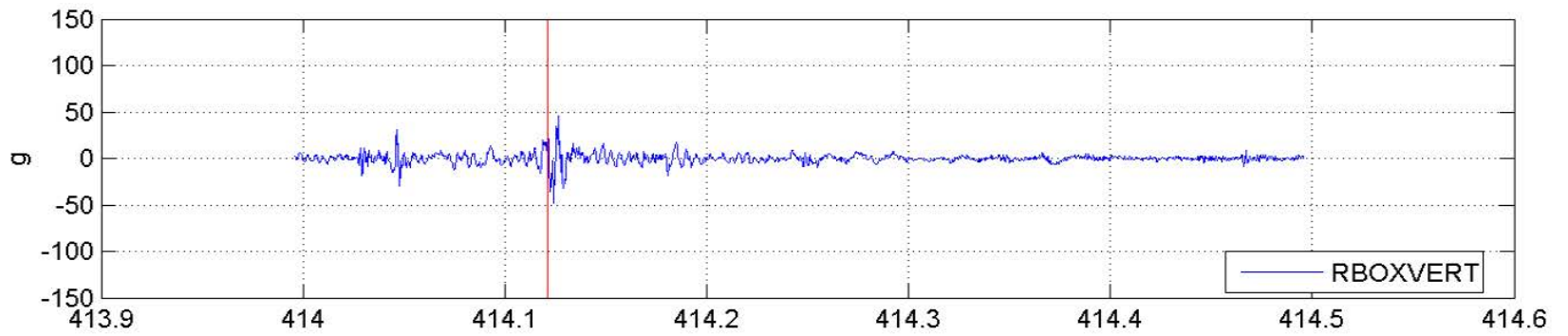
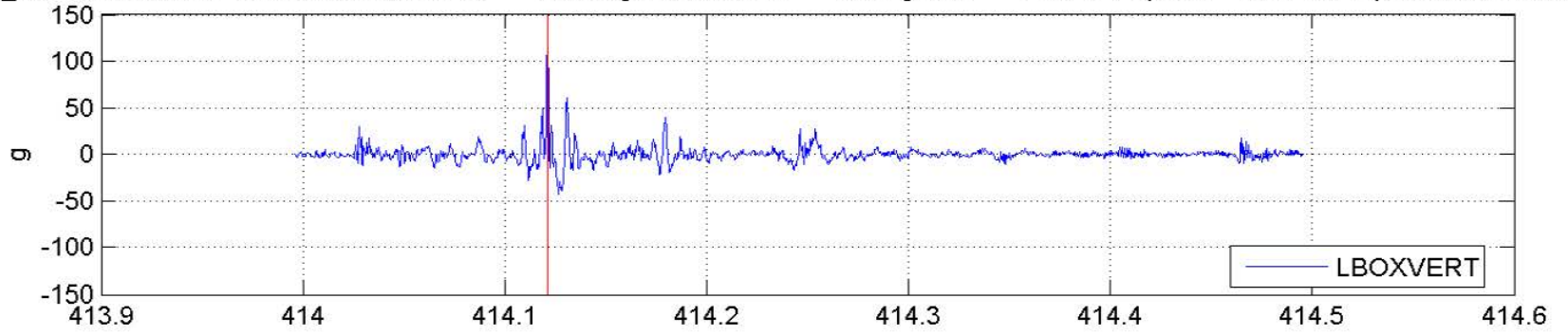

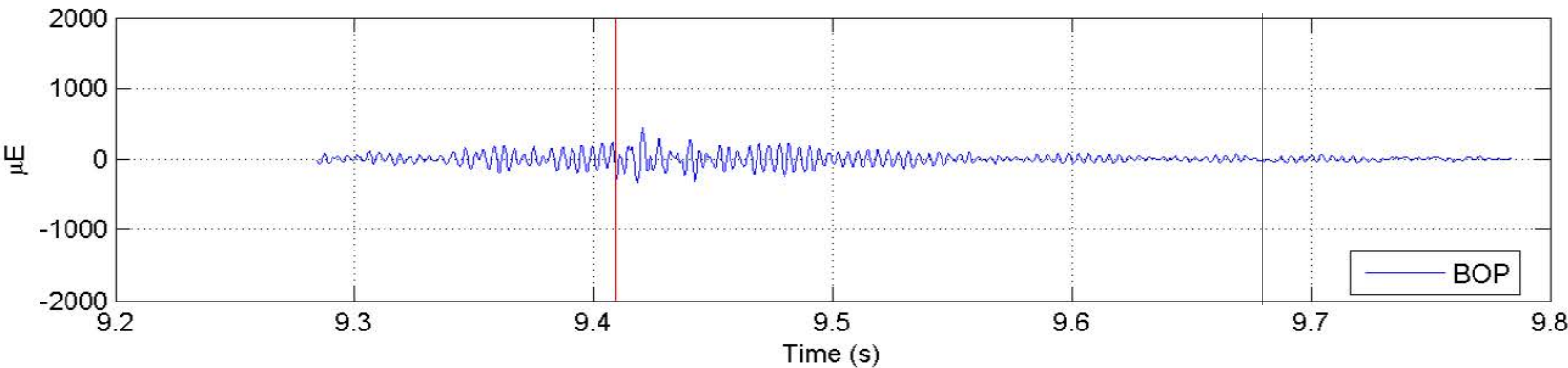
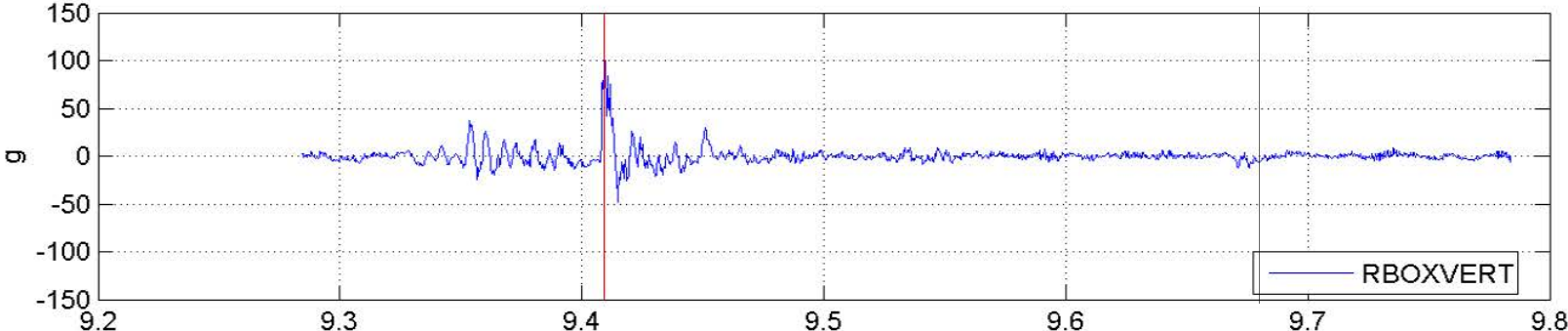
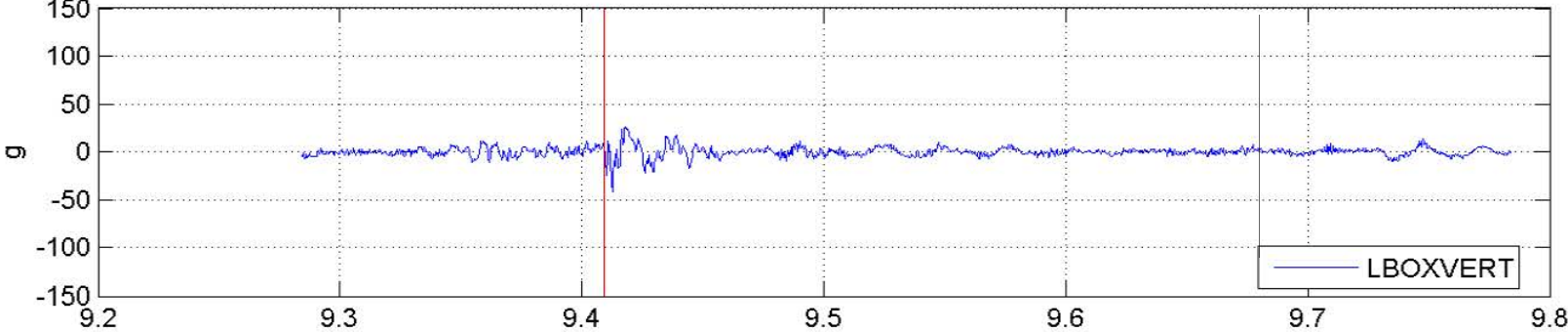

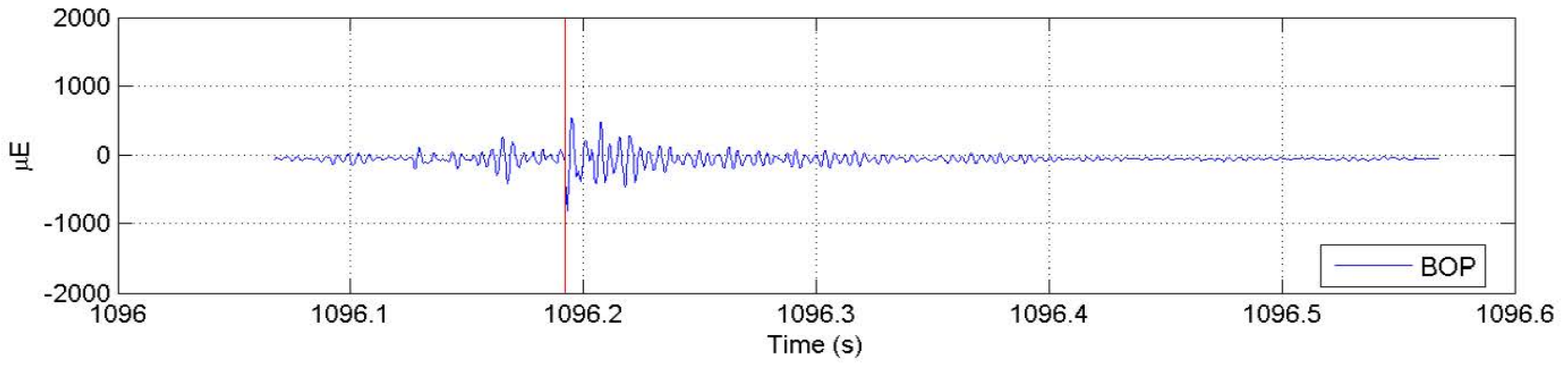
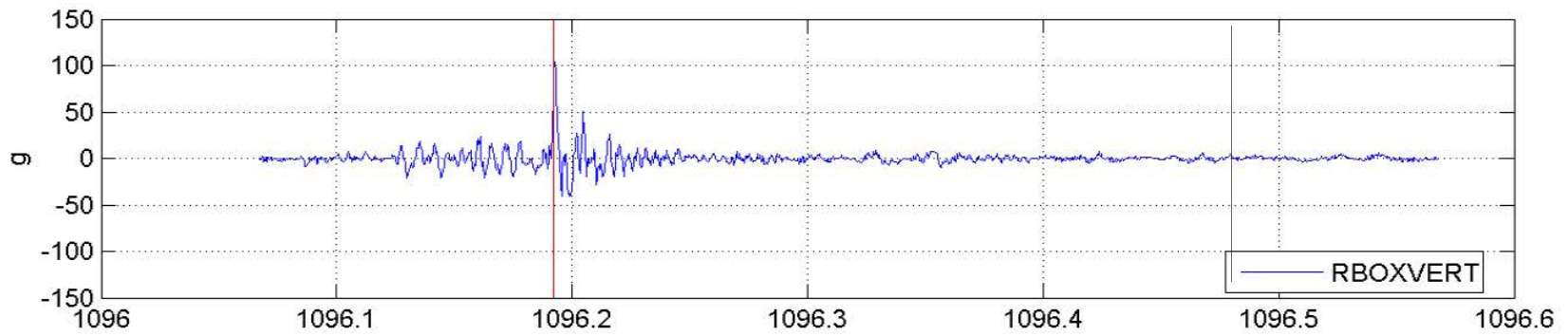
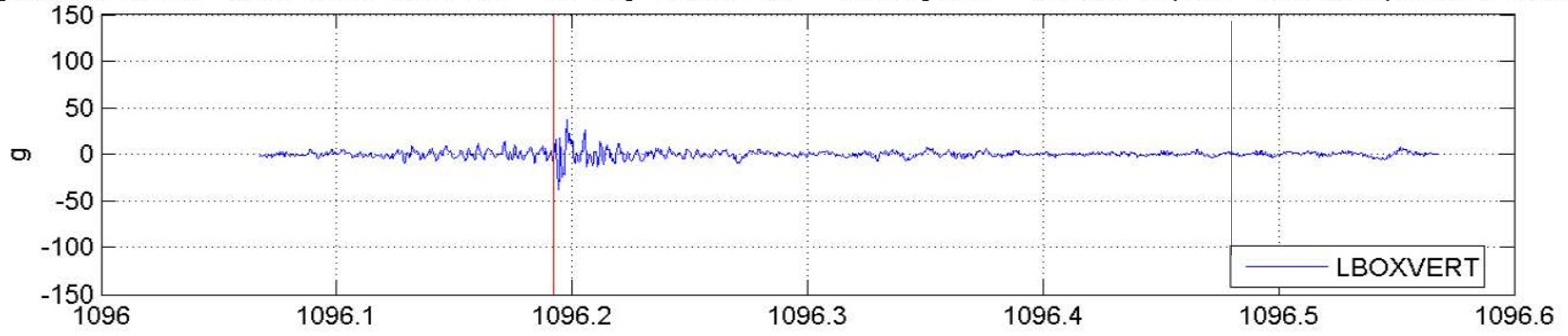

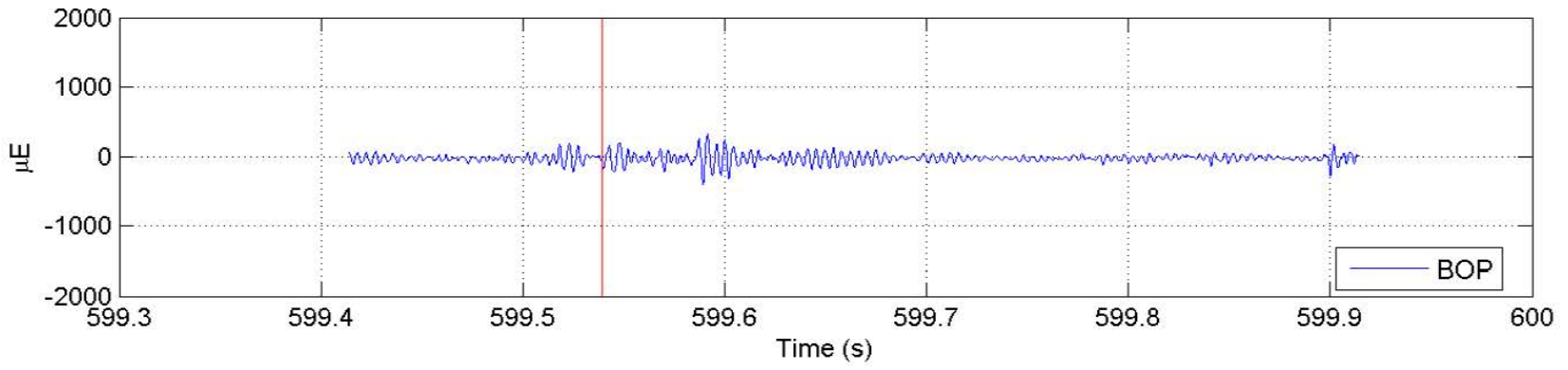
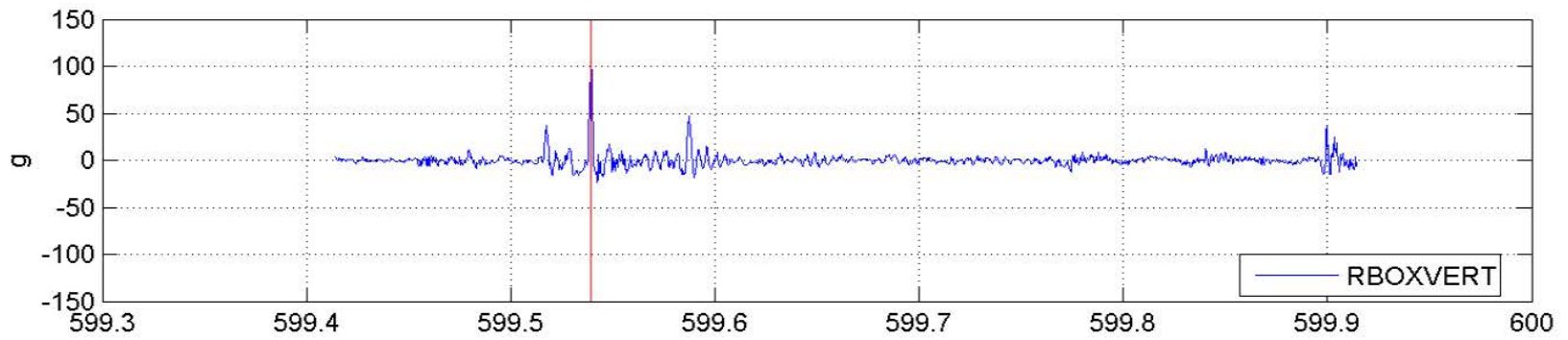
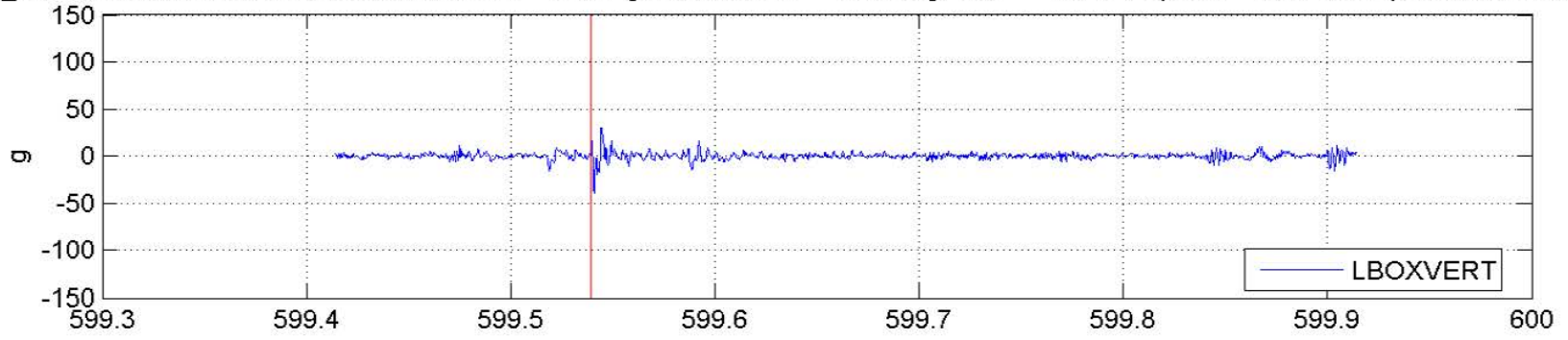

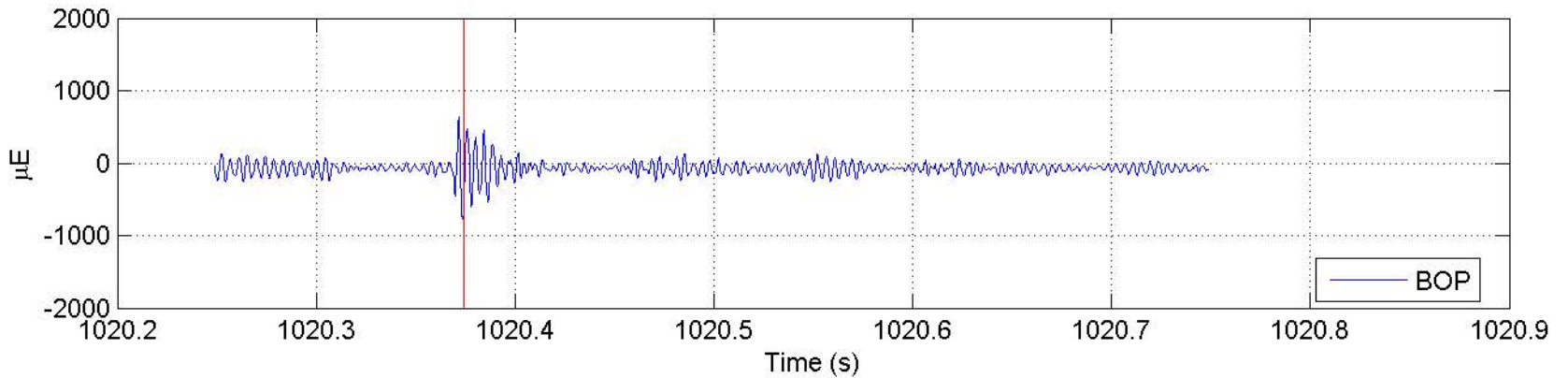
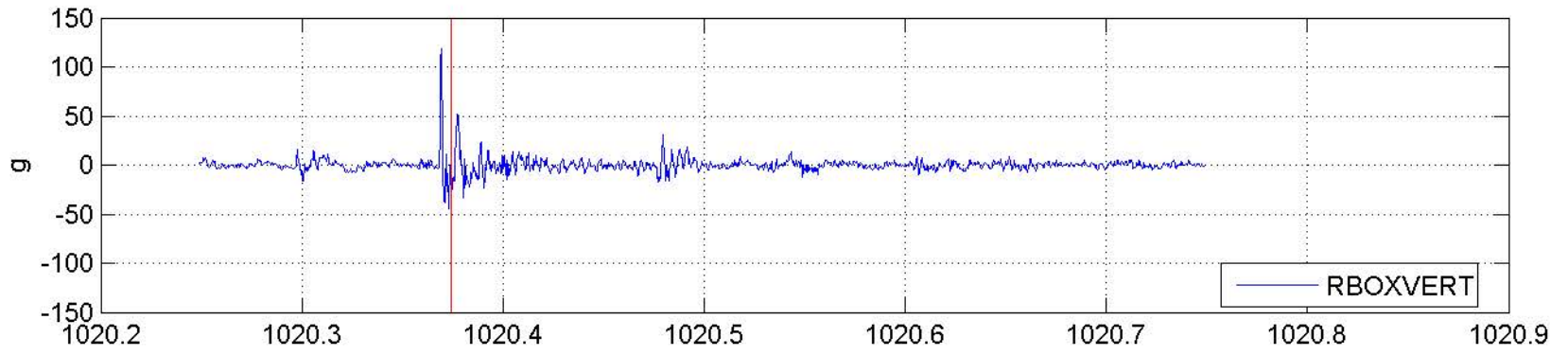
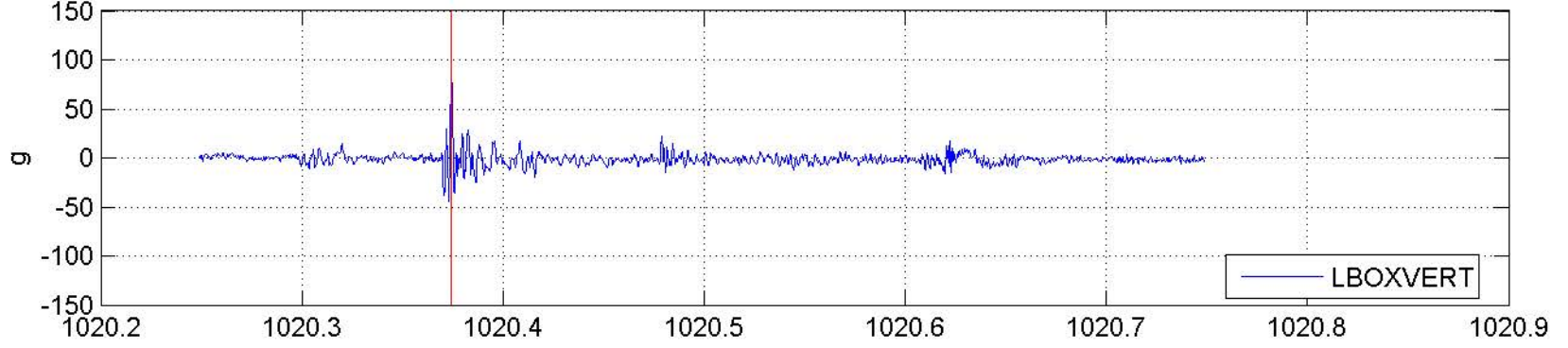

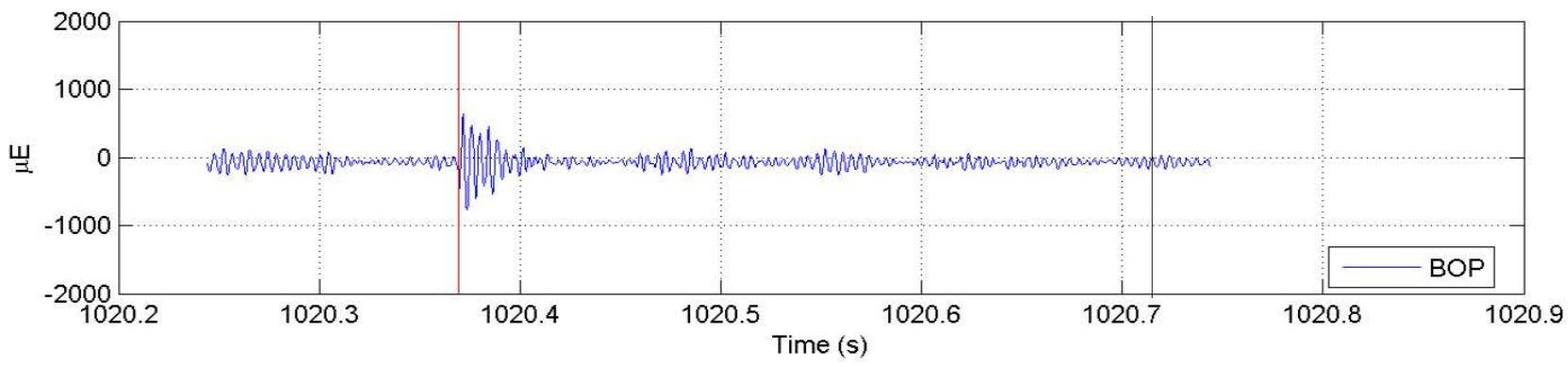
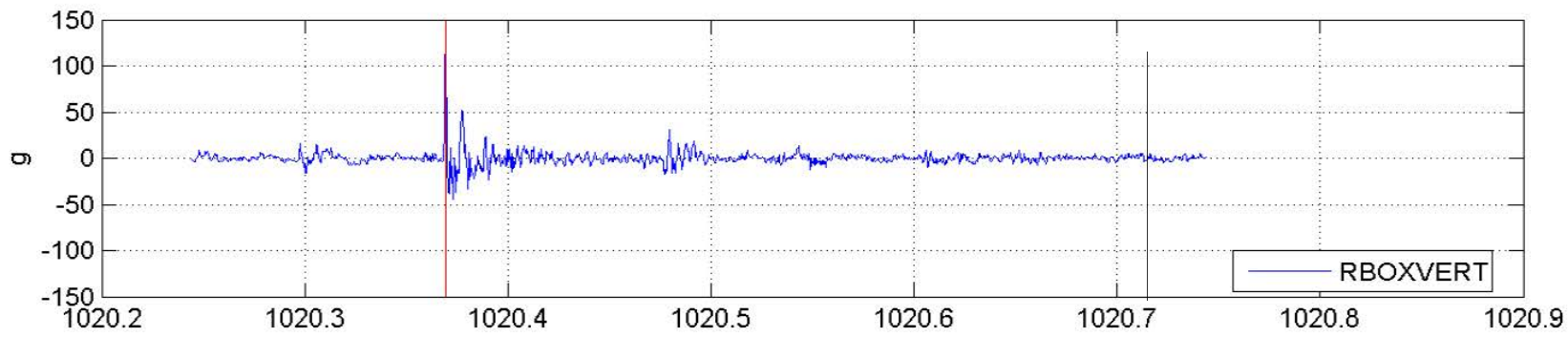
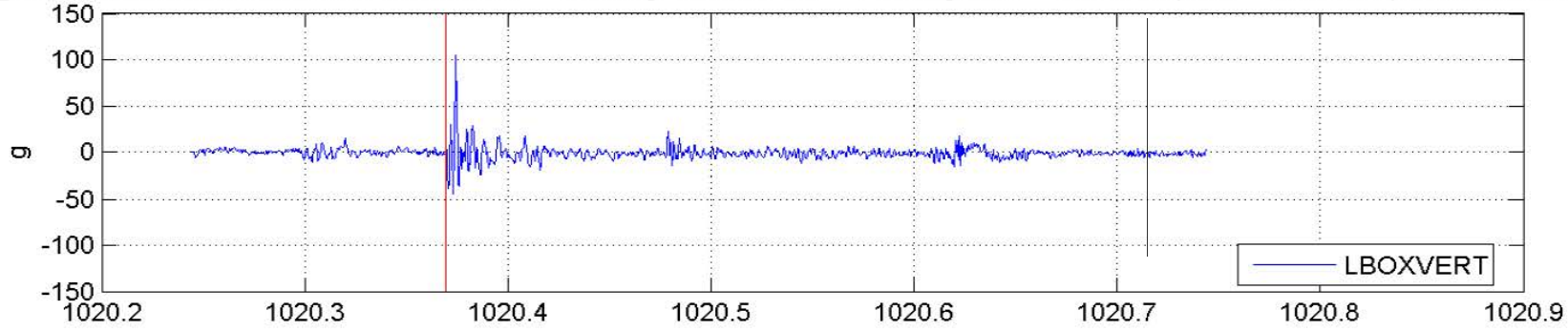

Day 6–June 17, 2005

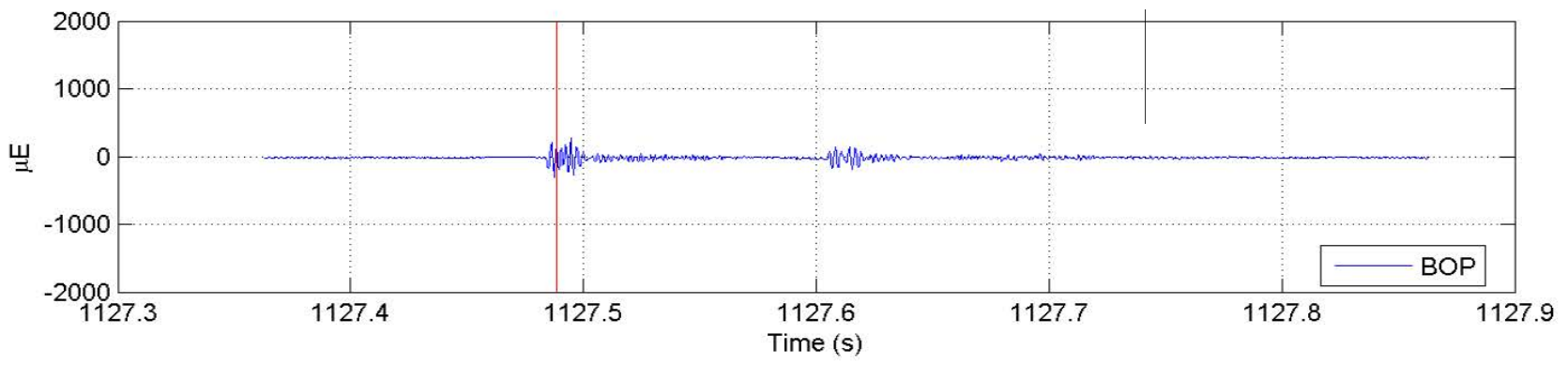
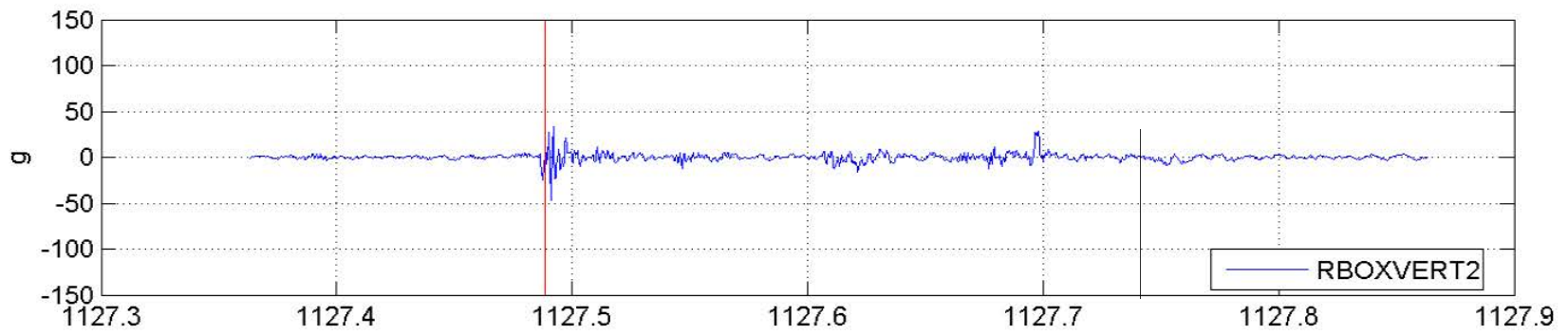
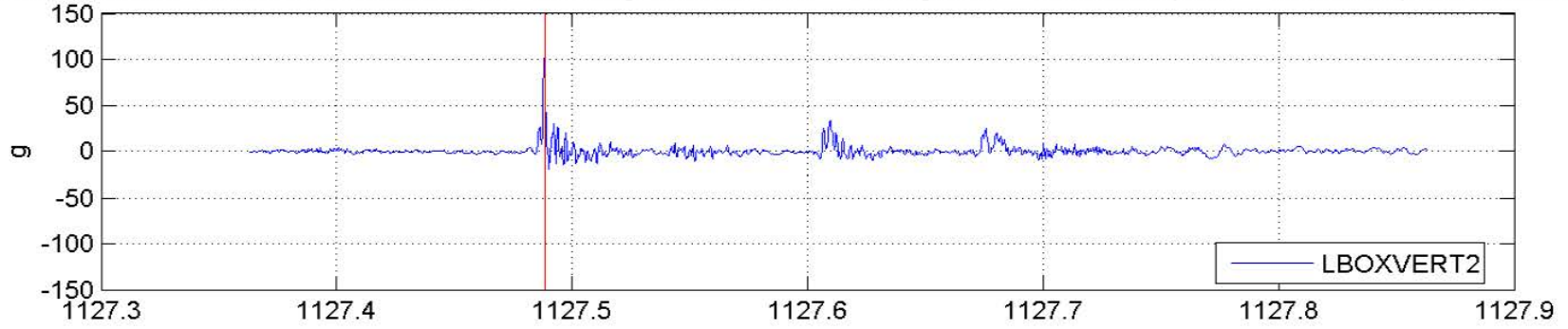

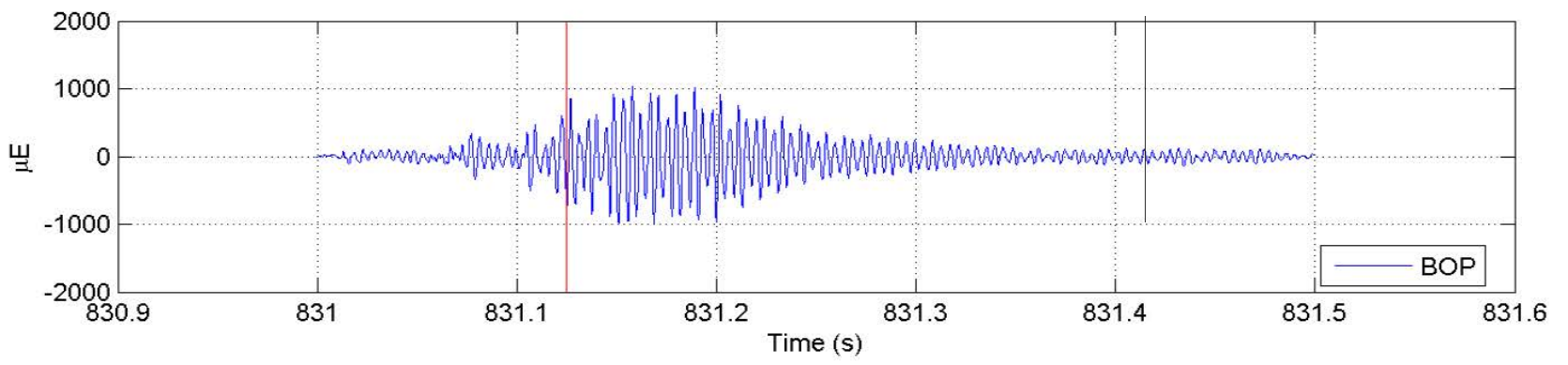
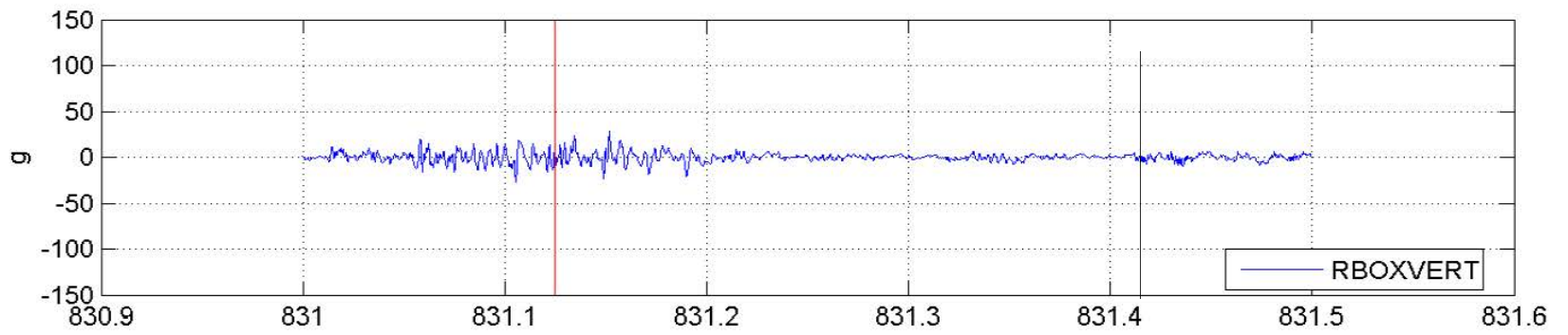
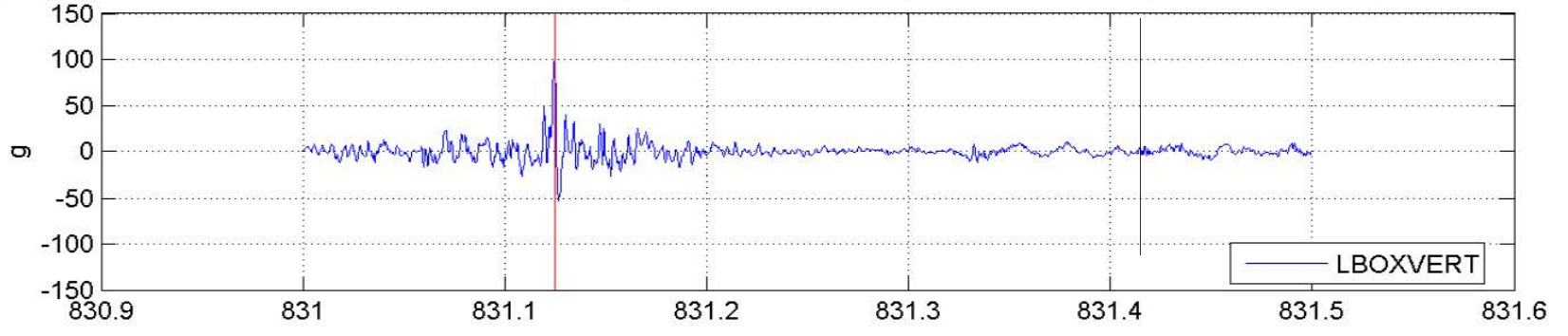

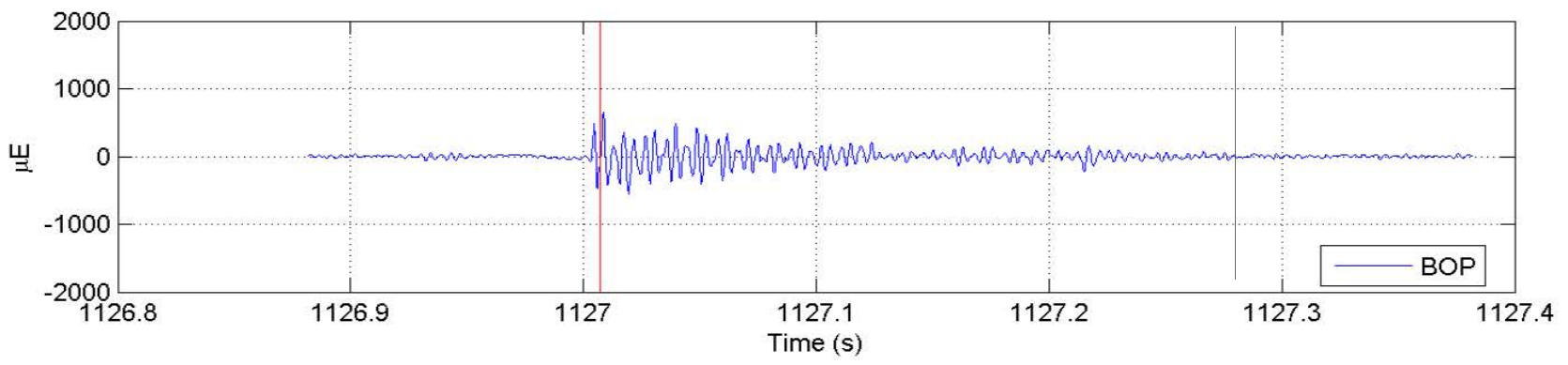
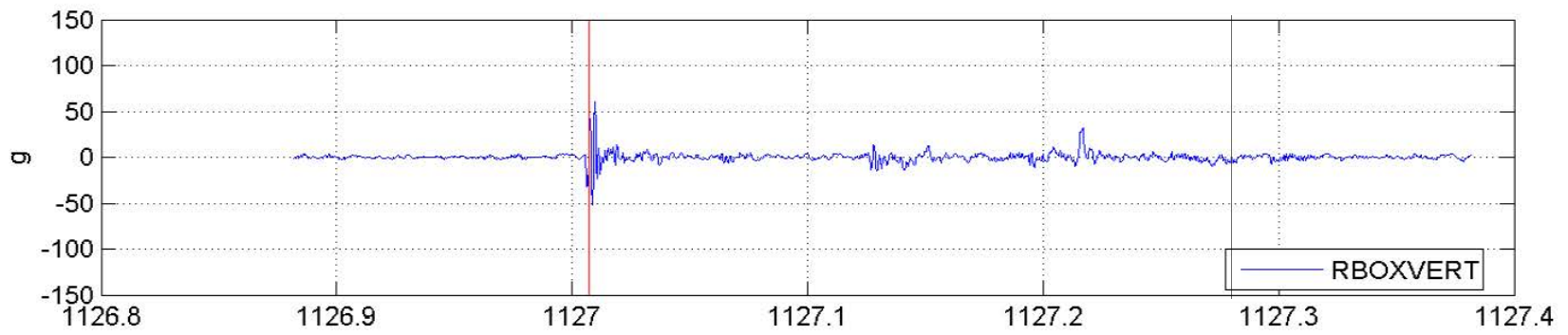
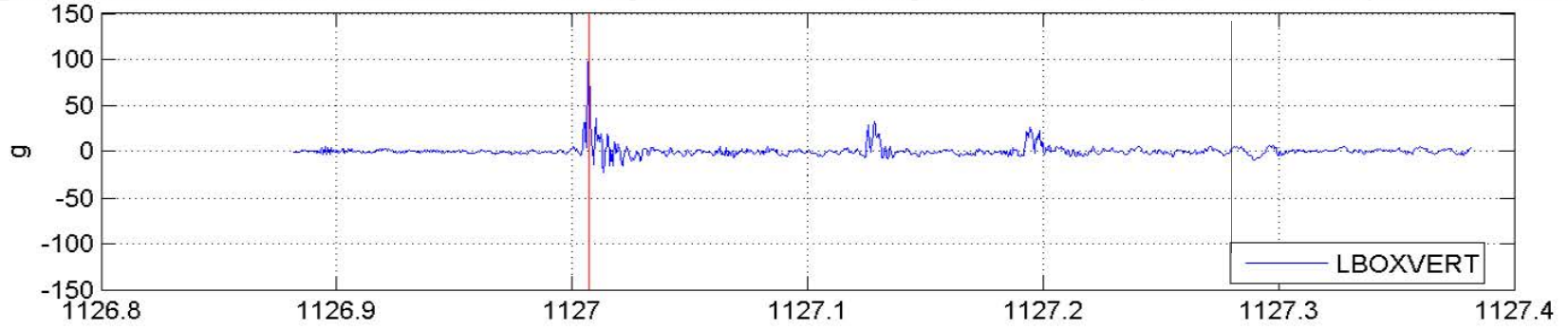

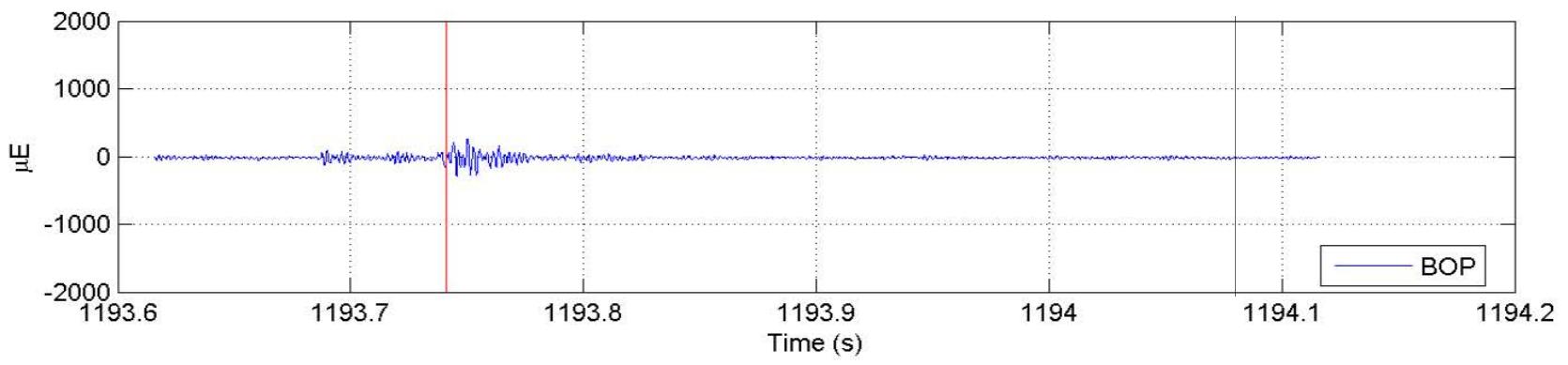
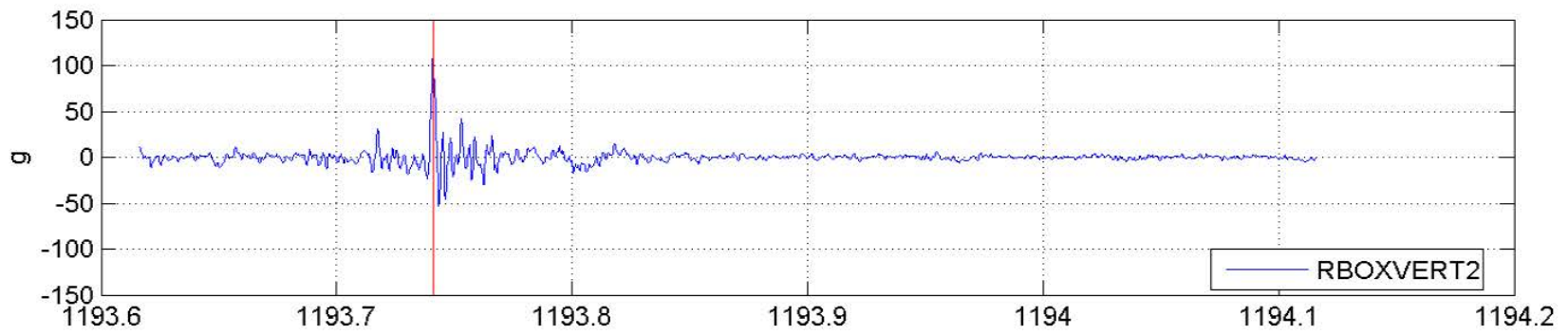
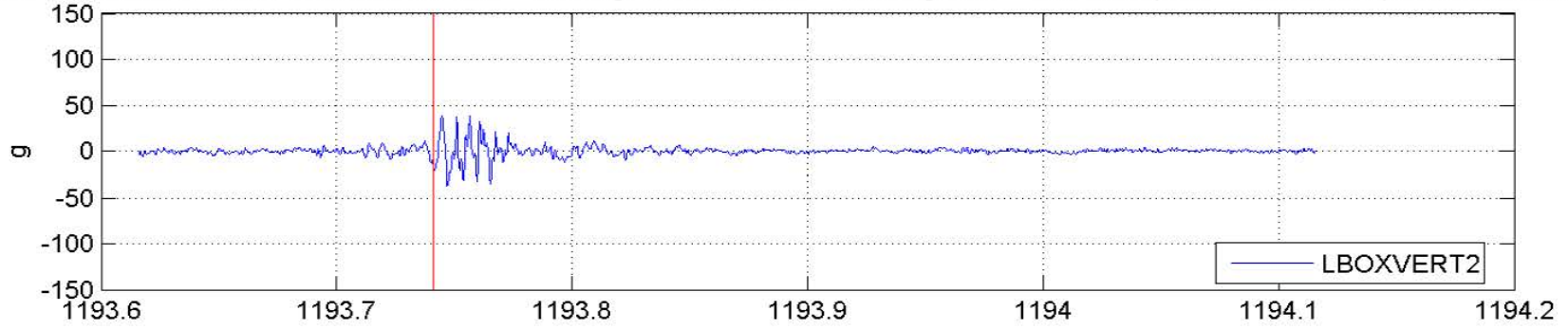

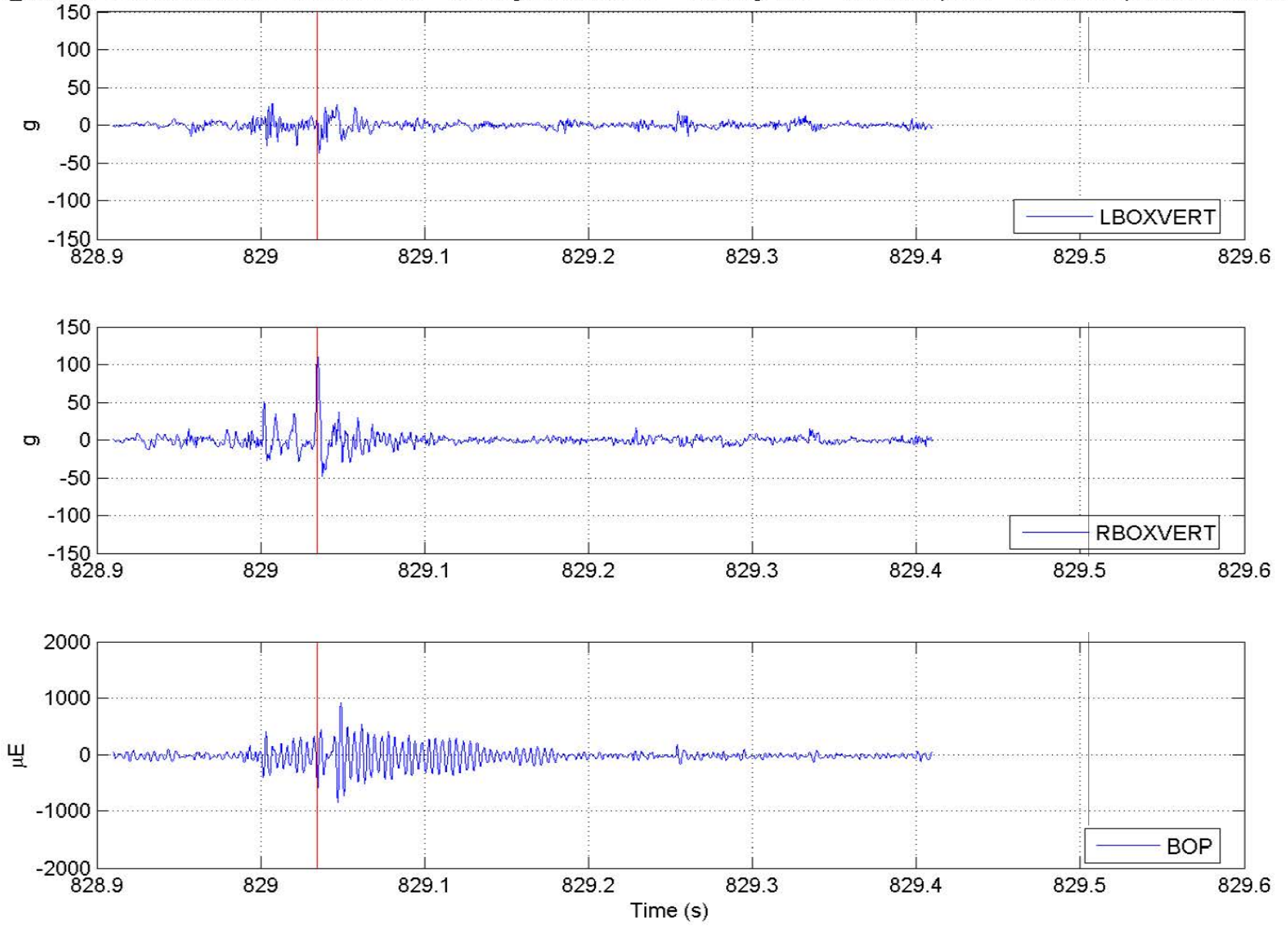

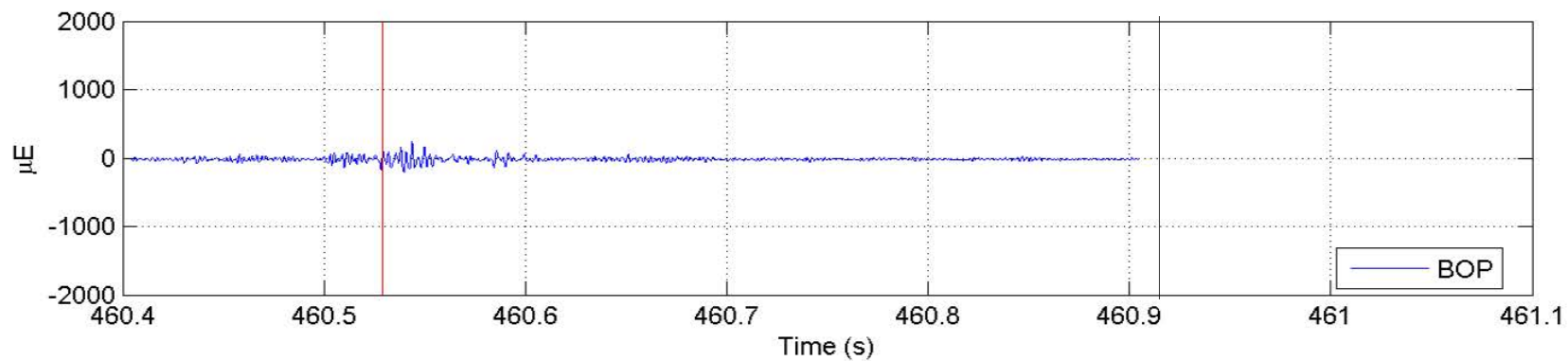
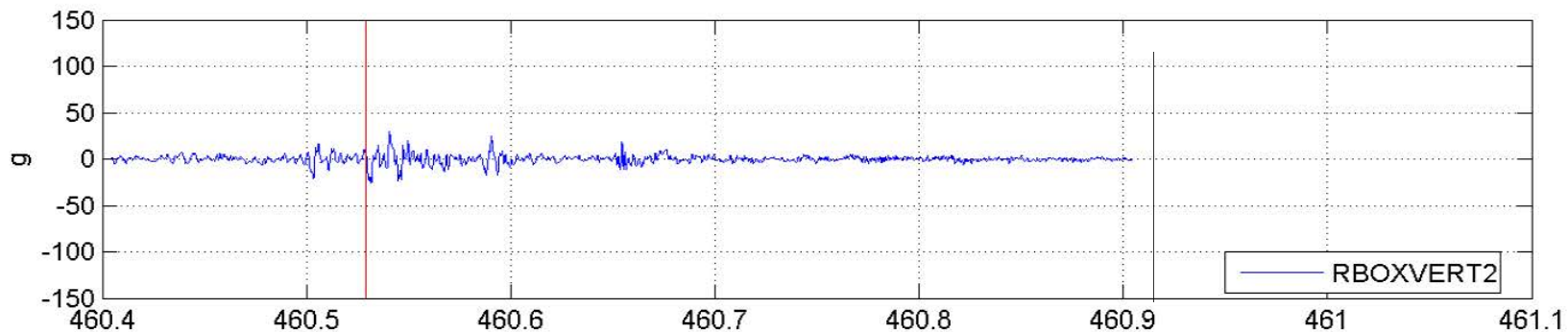
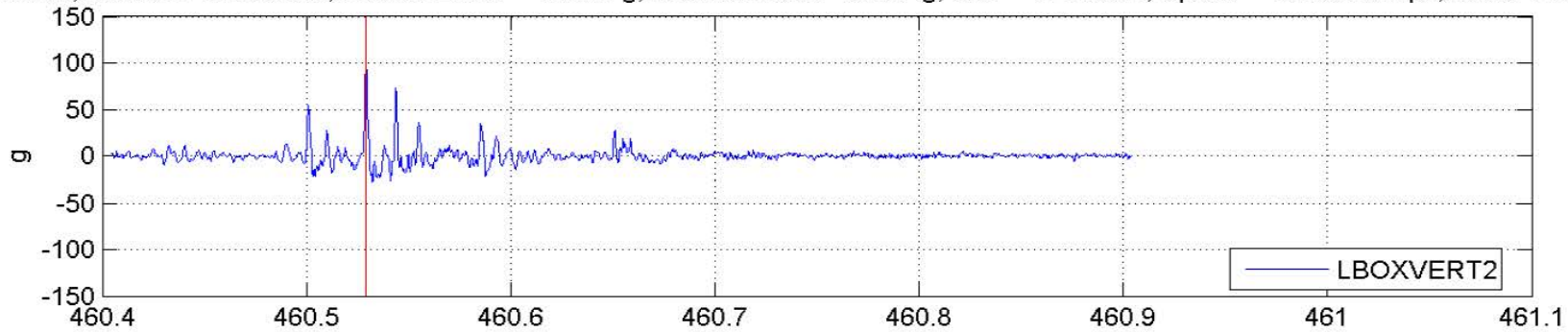

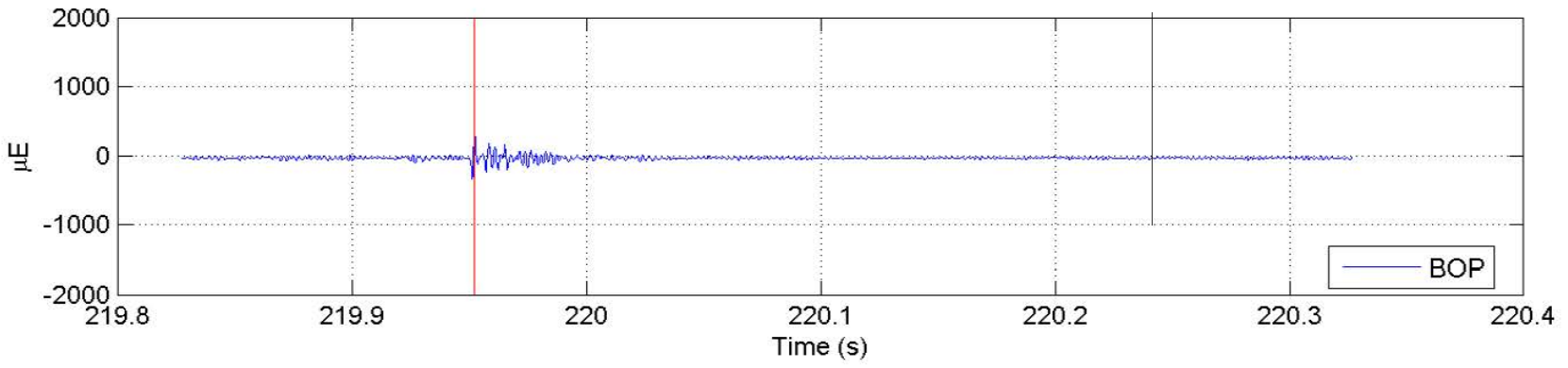
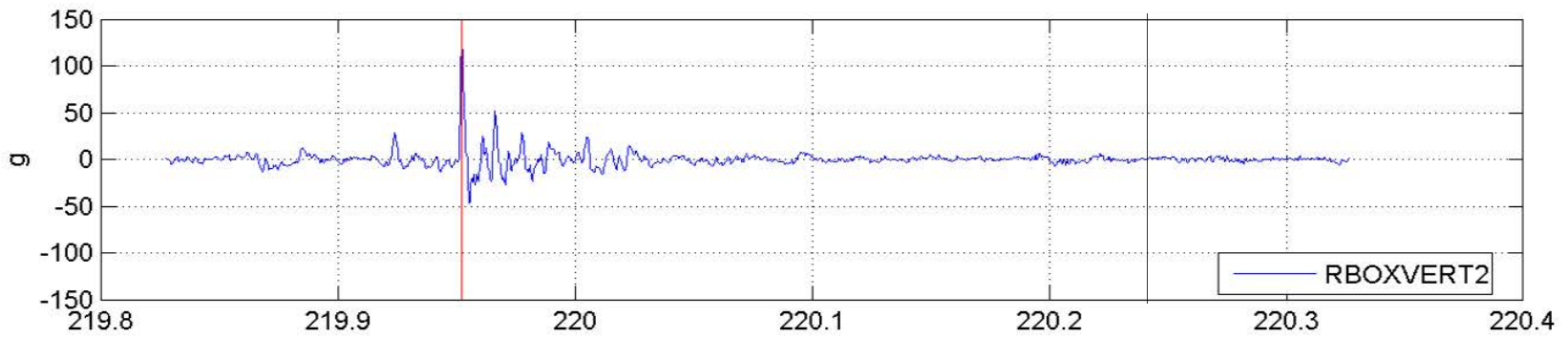
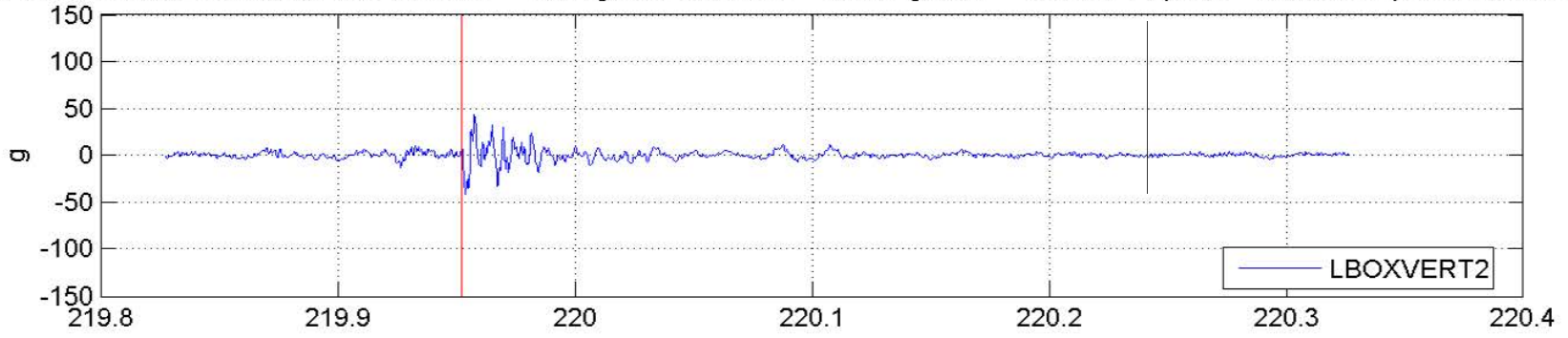

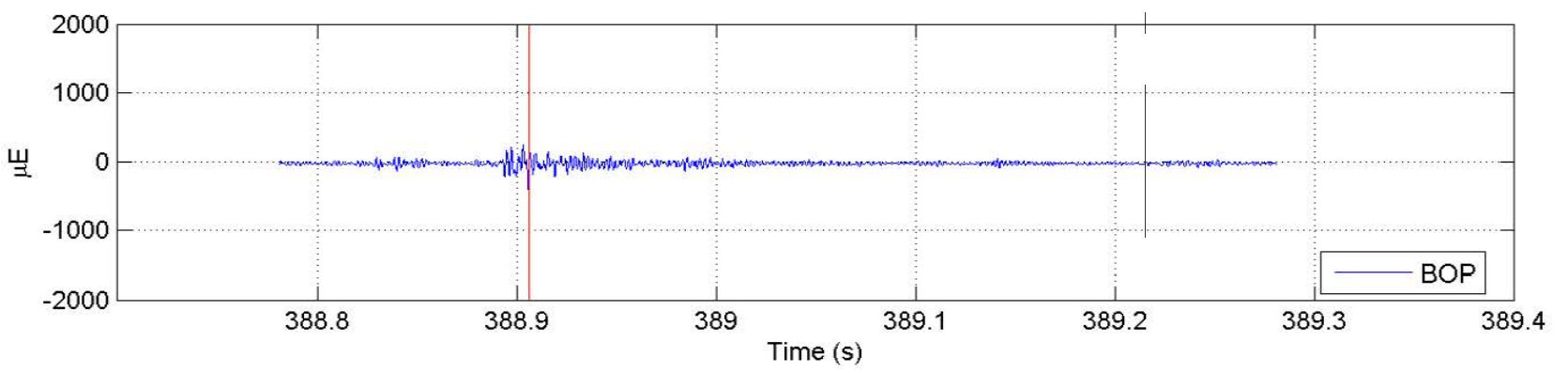
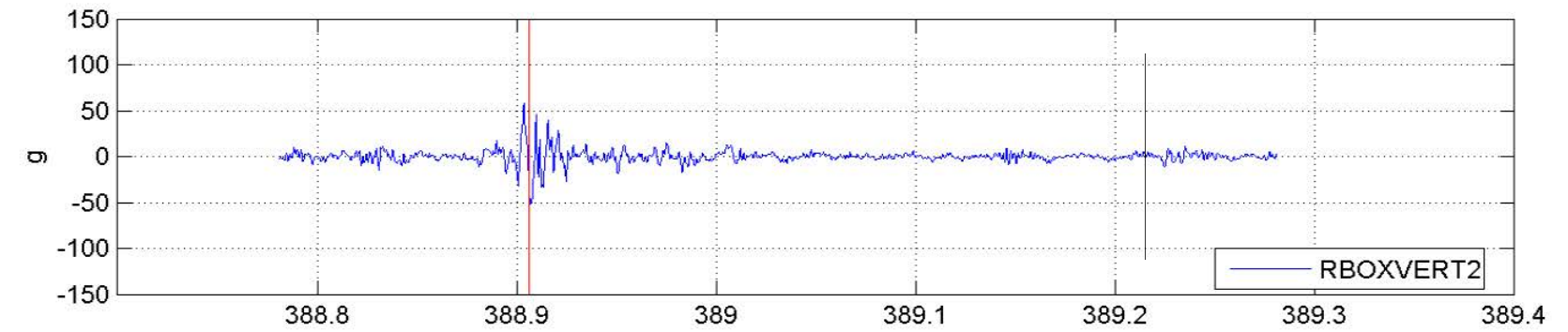
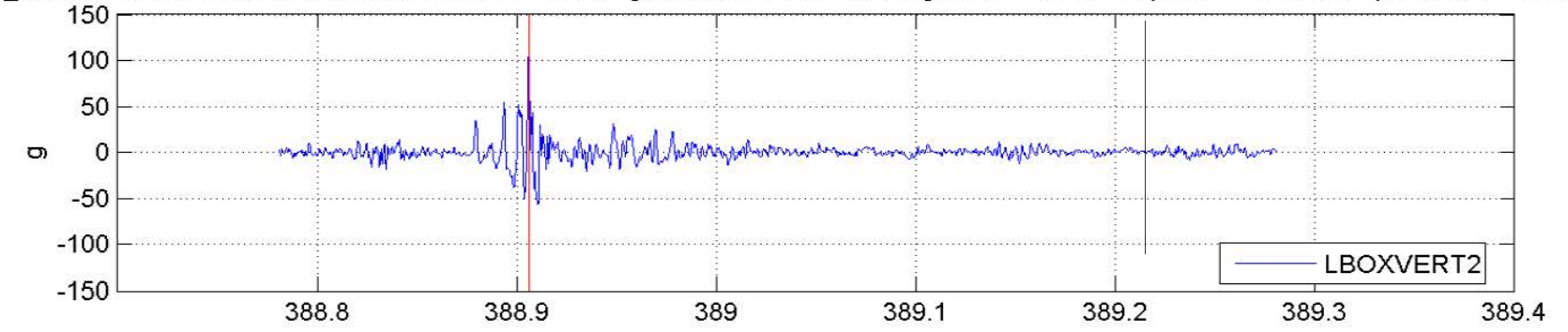

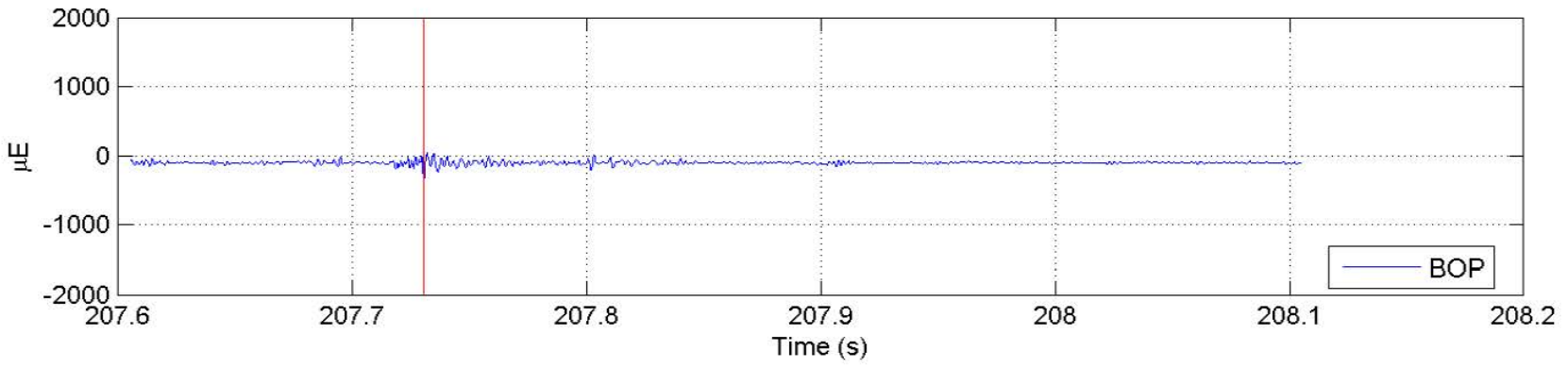
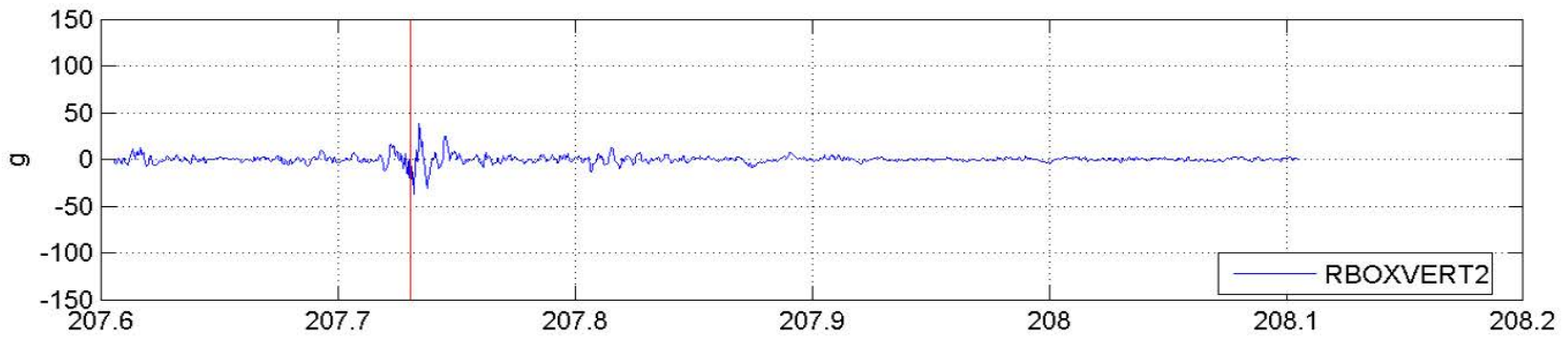
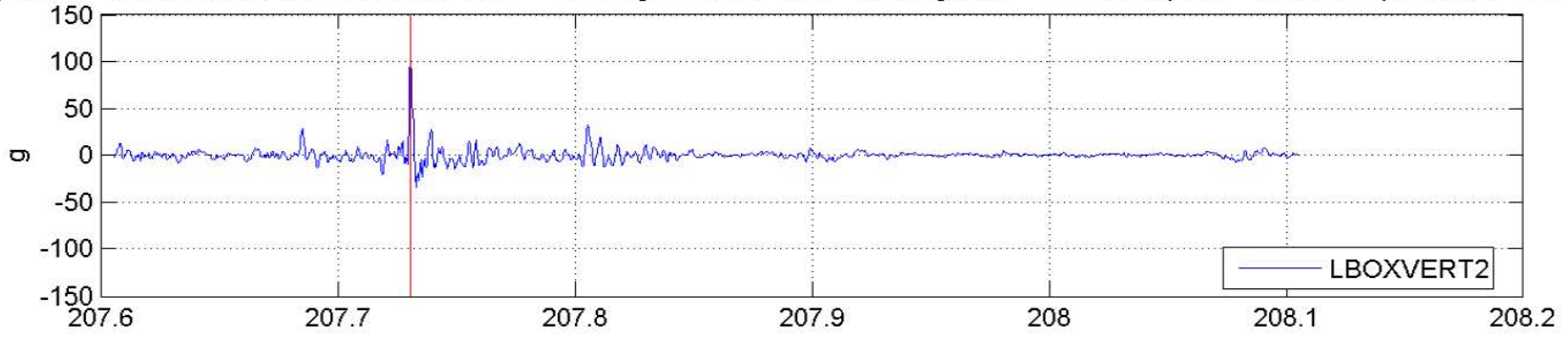

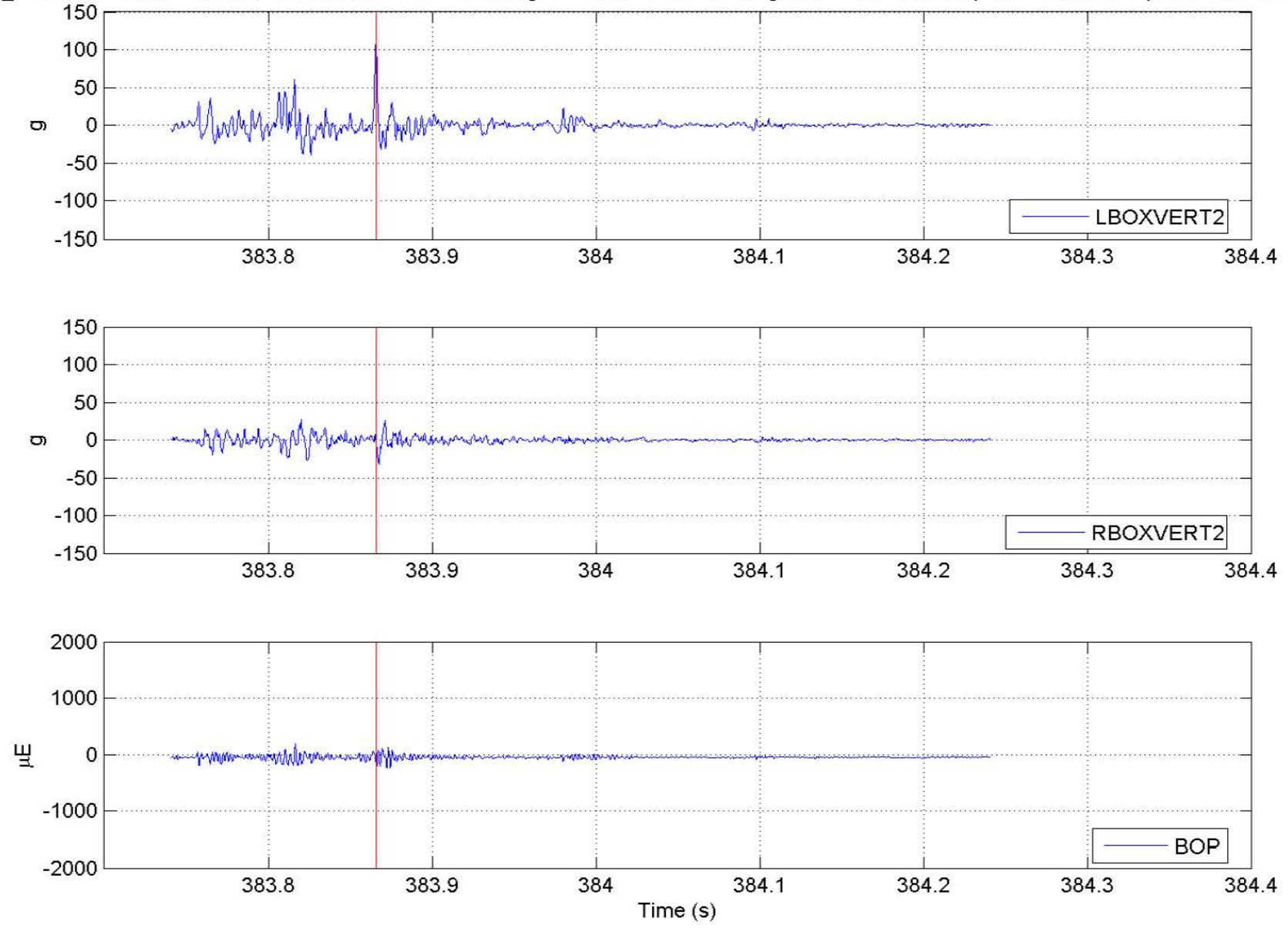

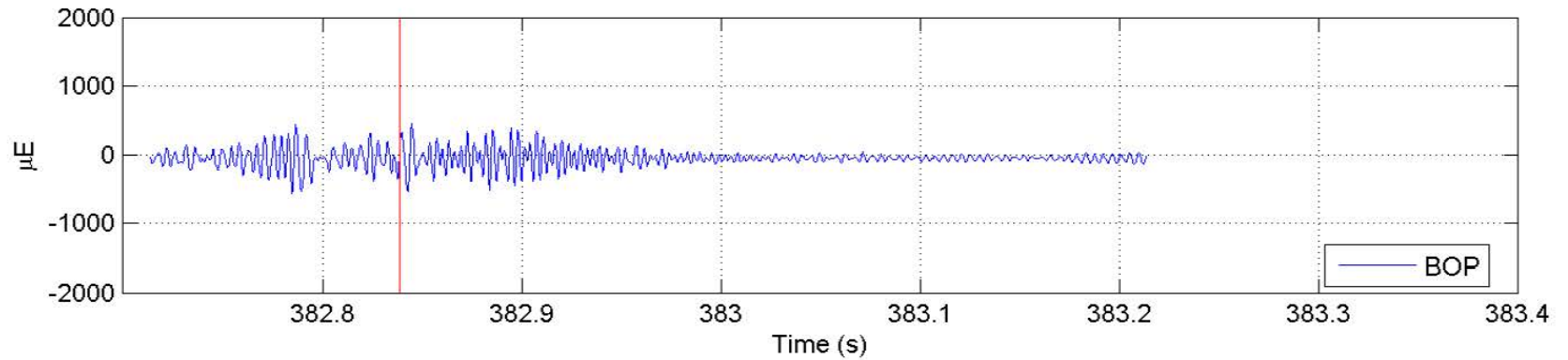
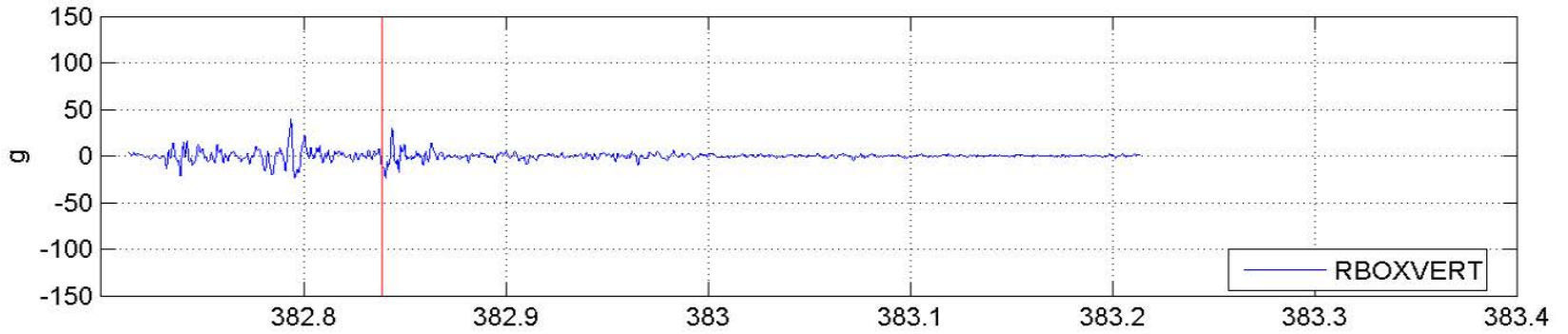
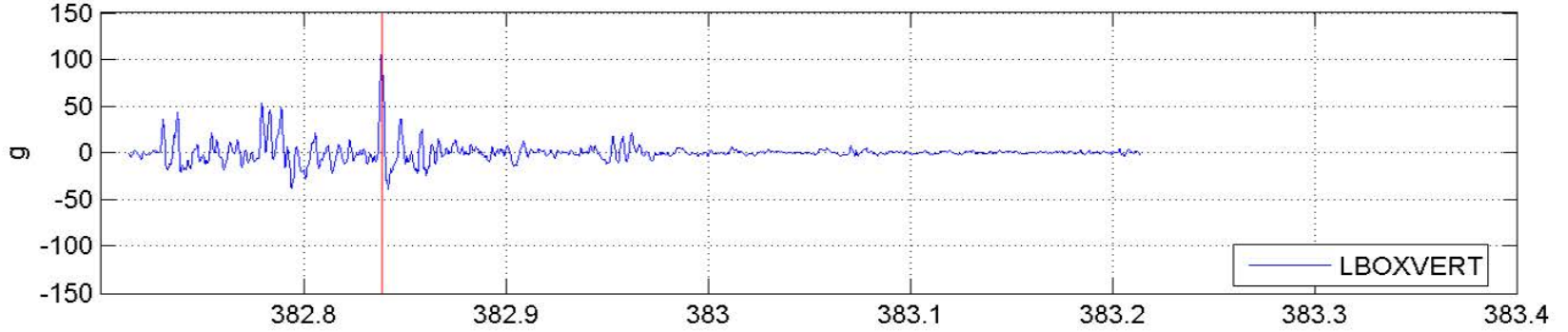

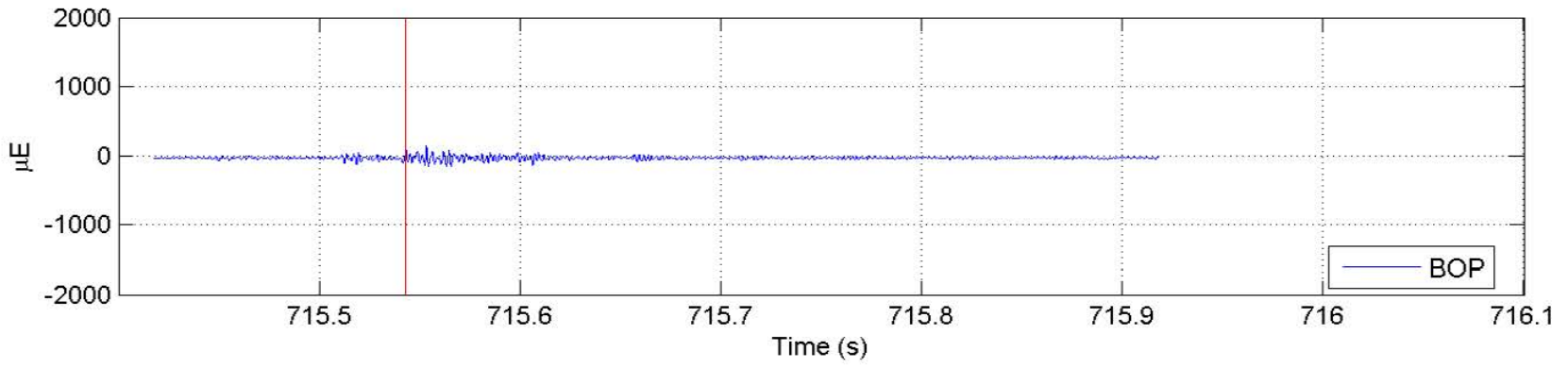
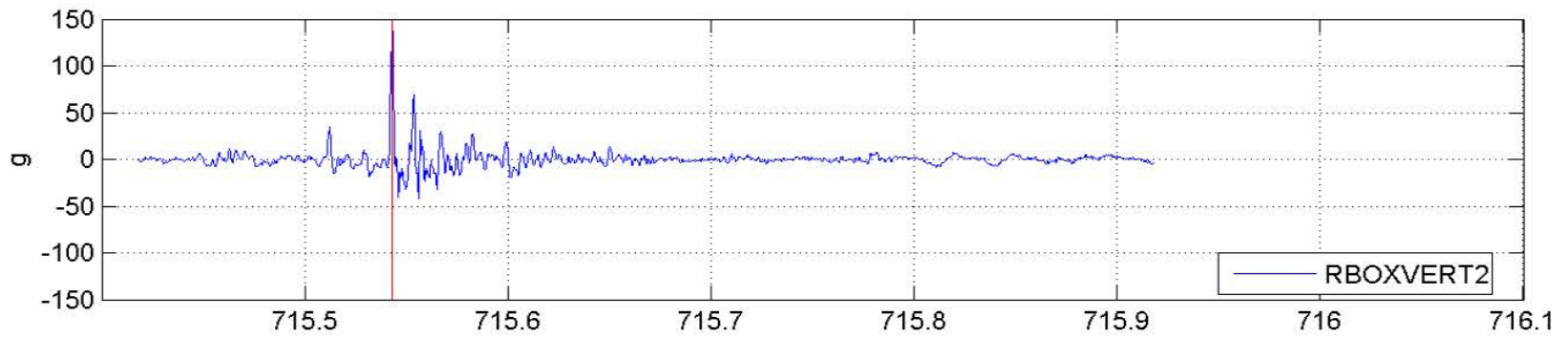
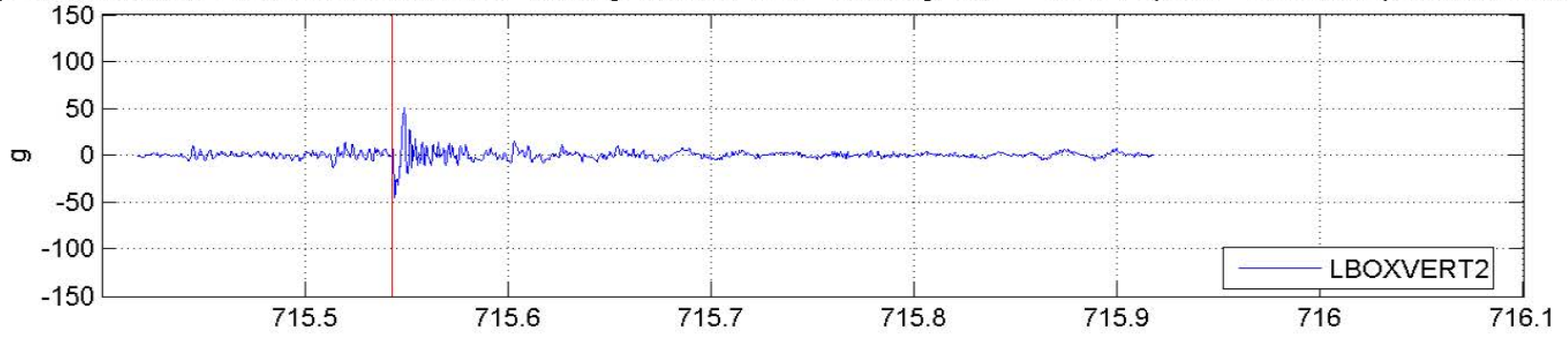

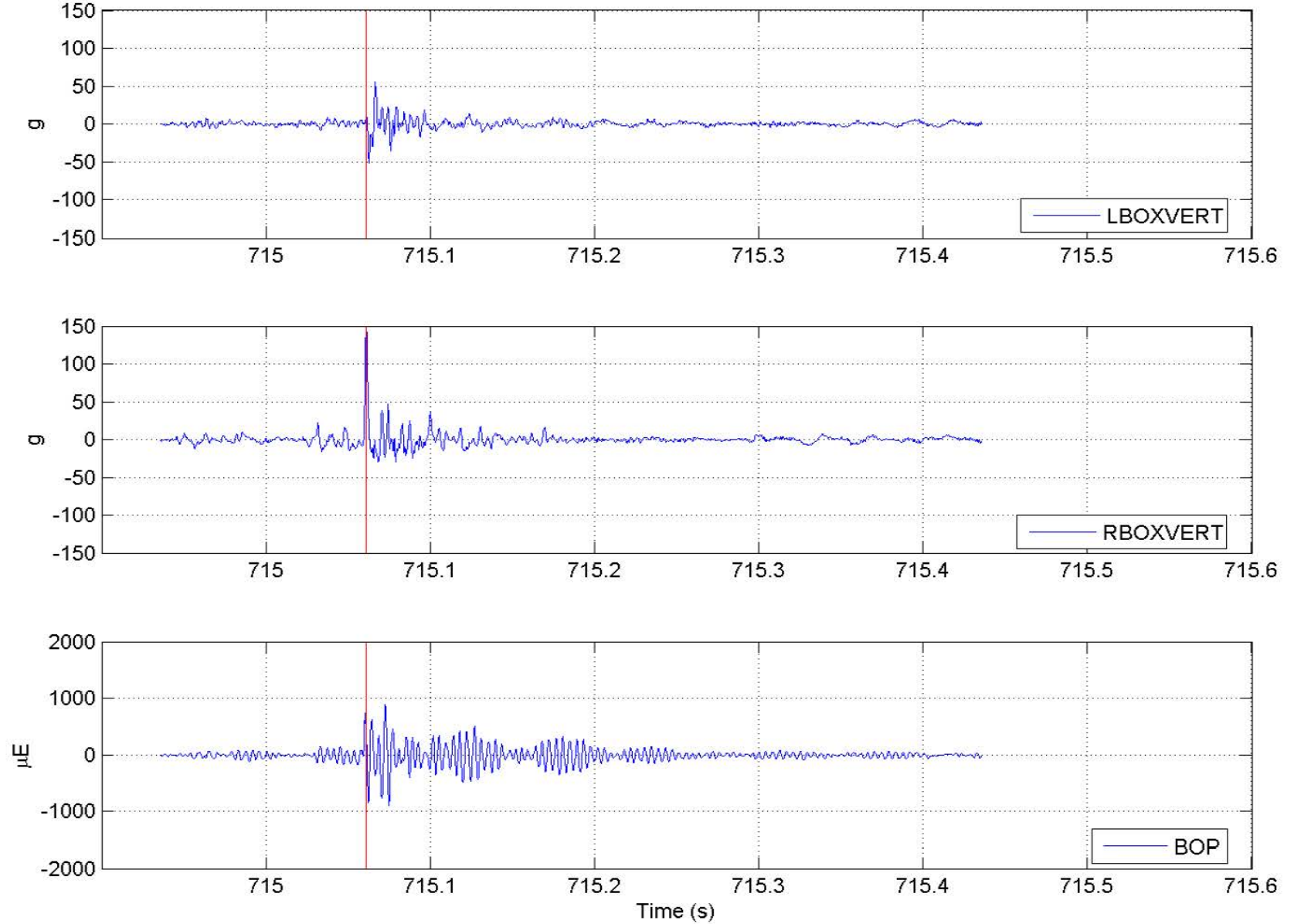

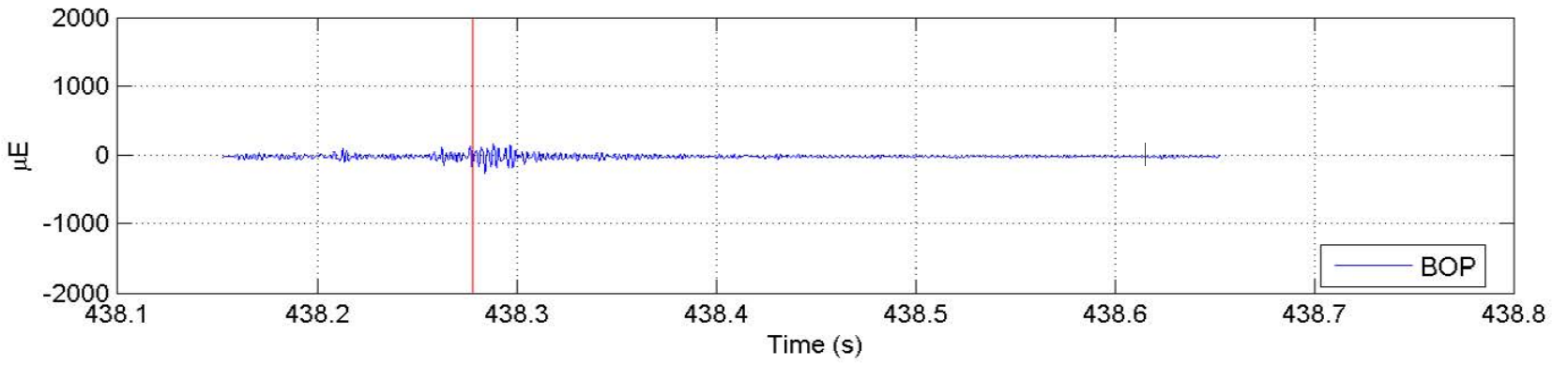
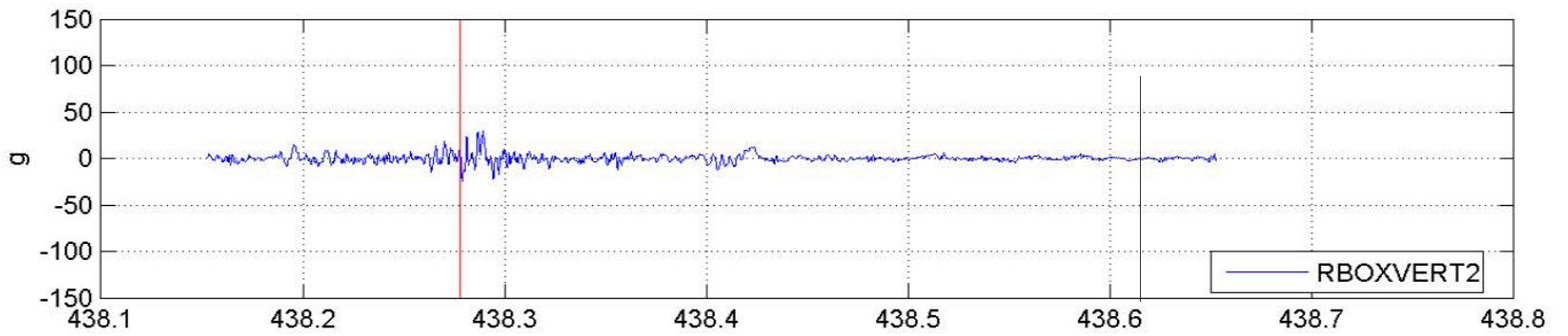
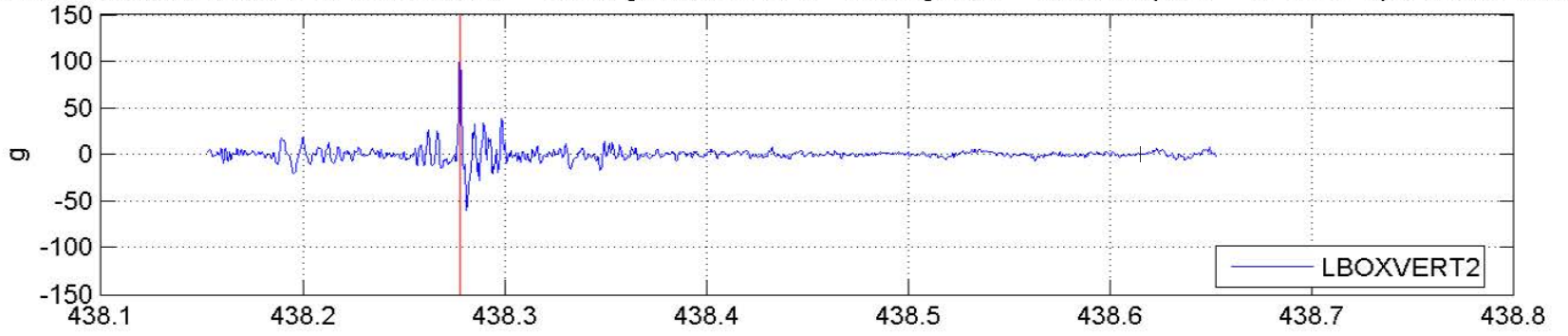

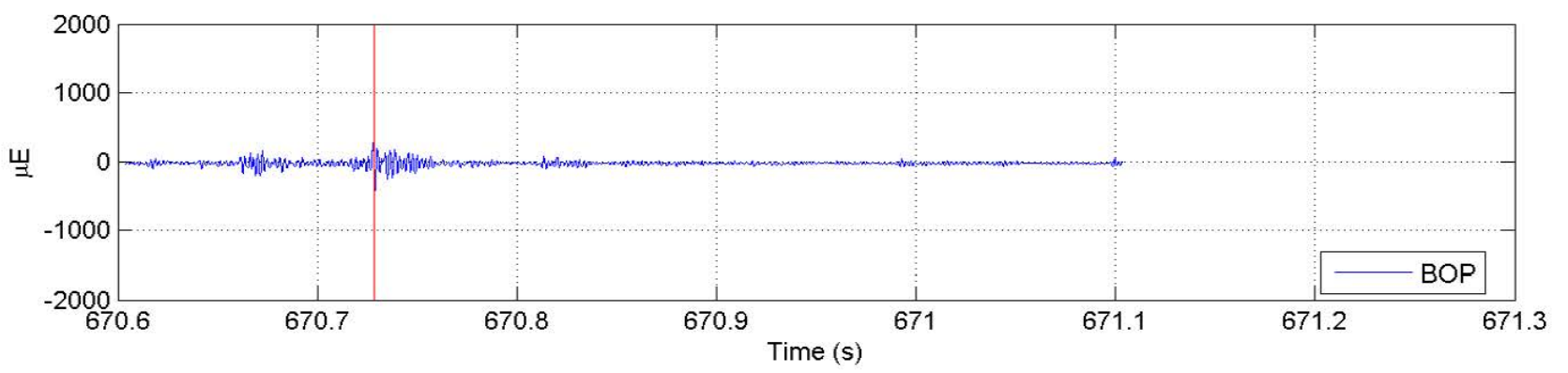
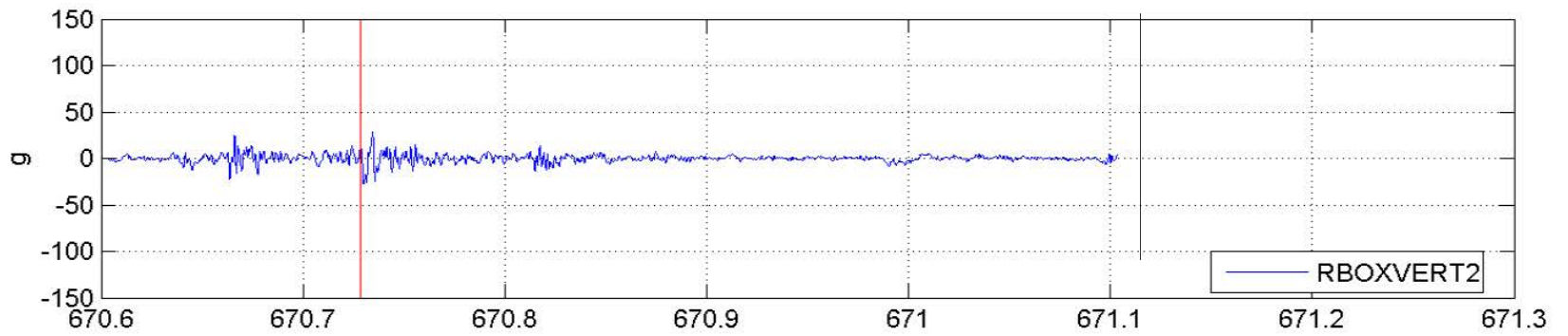
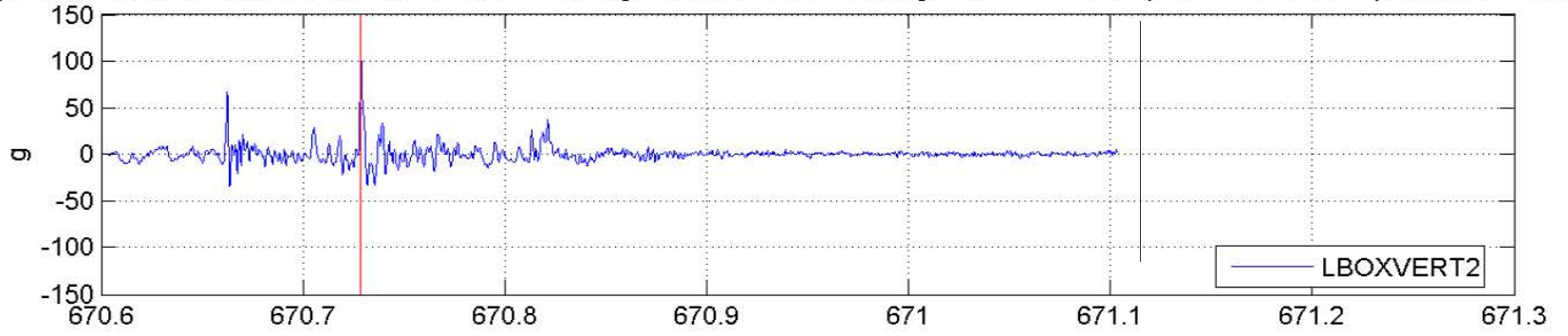

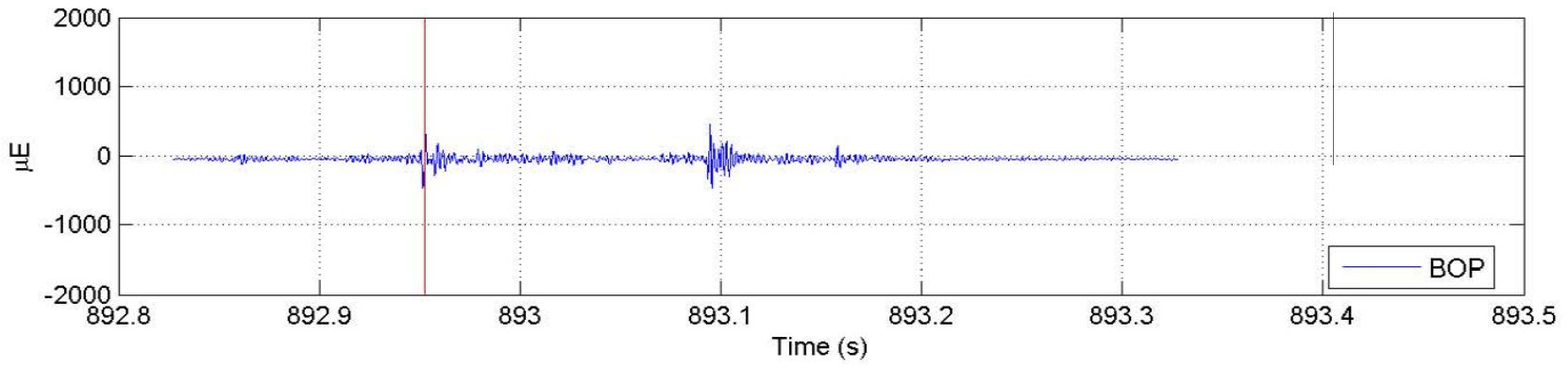
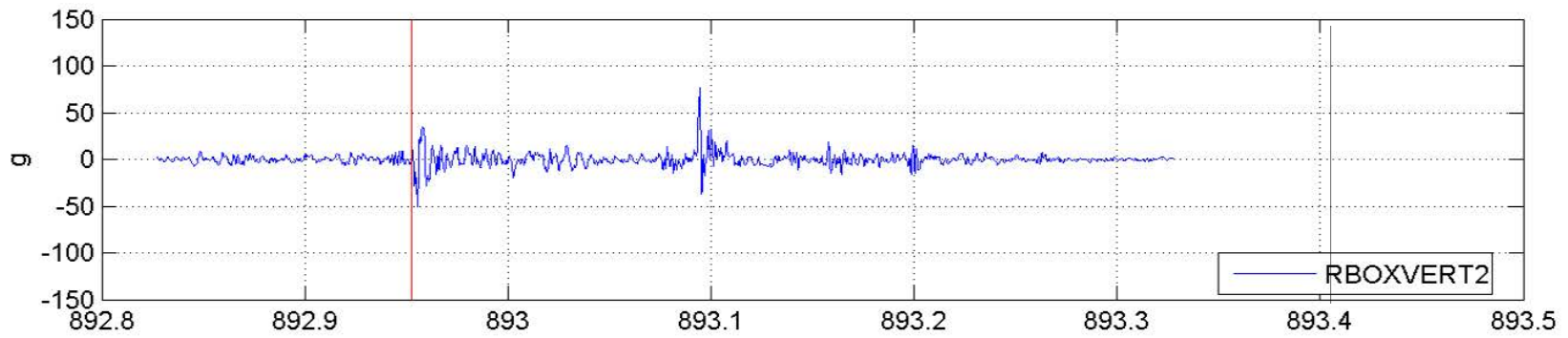
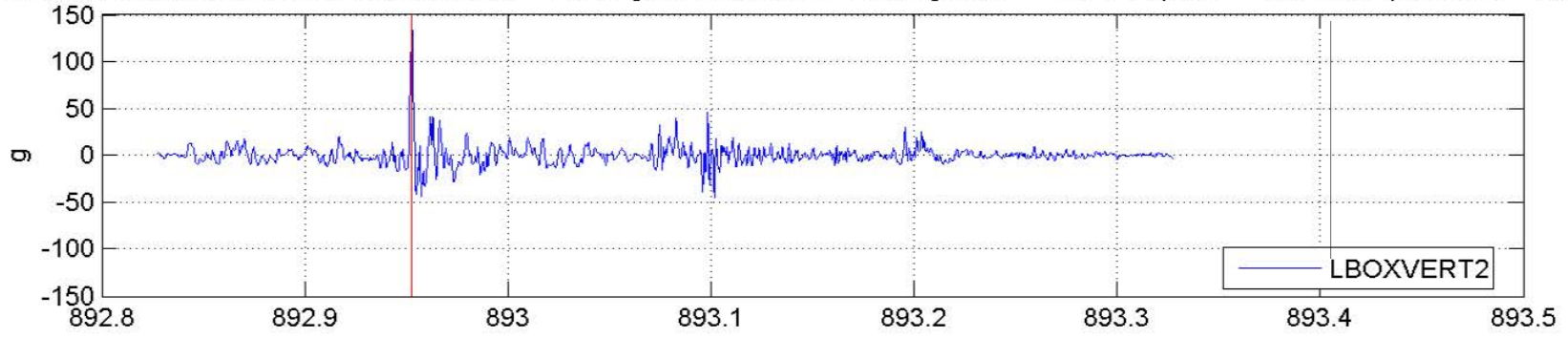

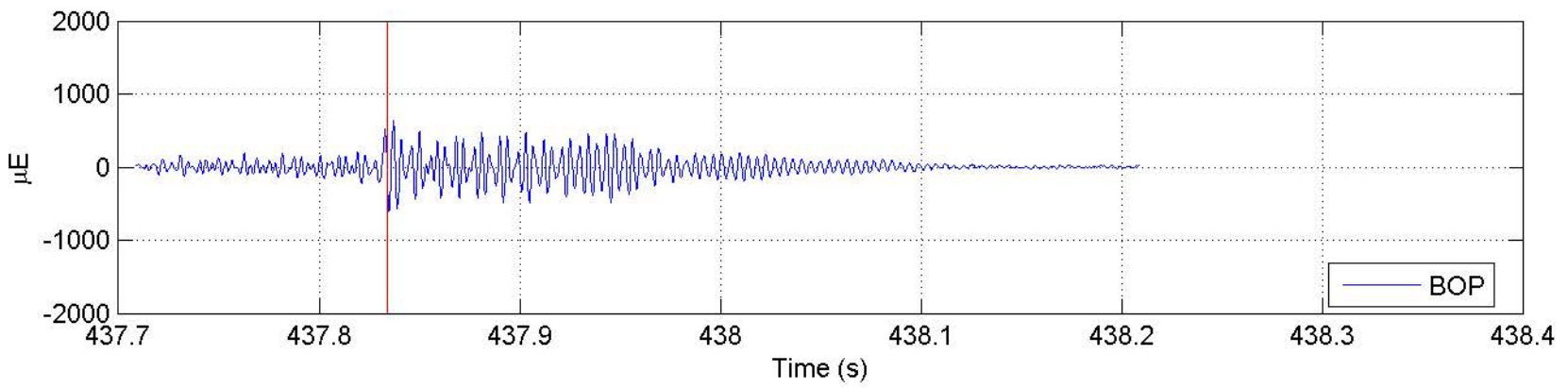
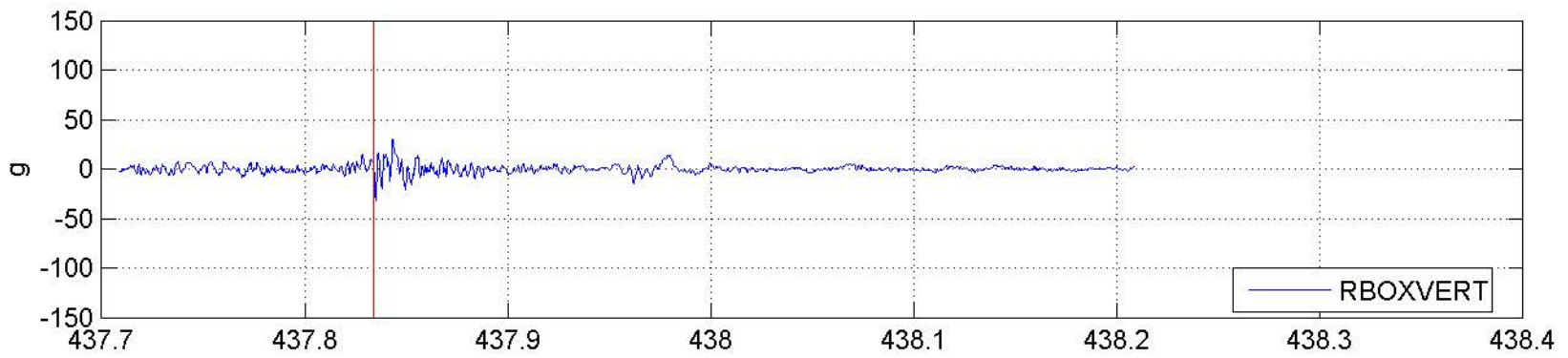
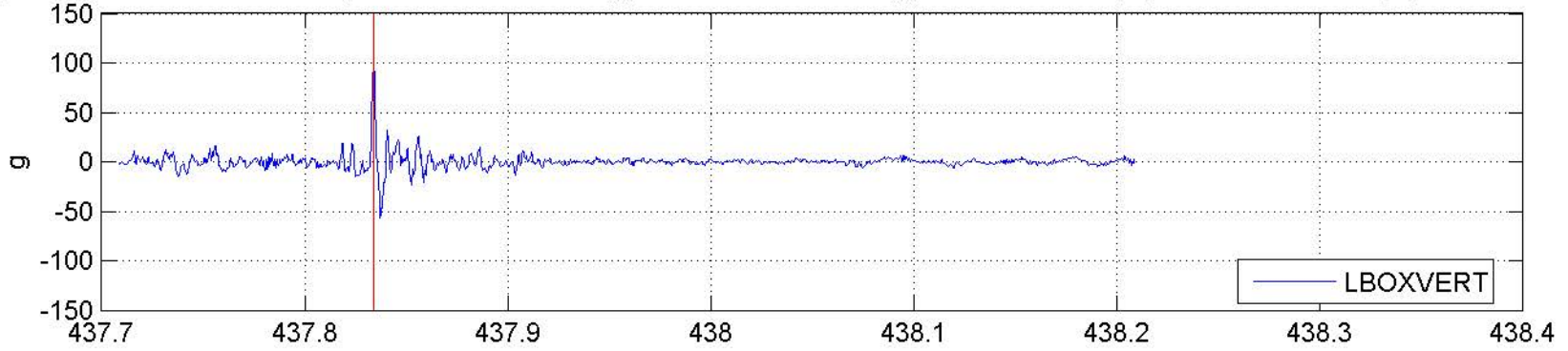

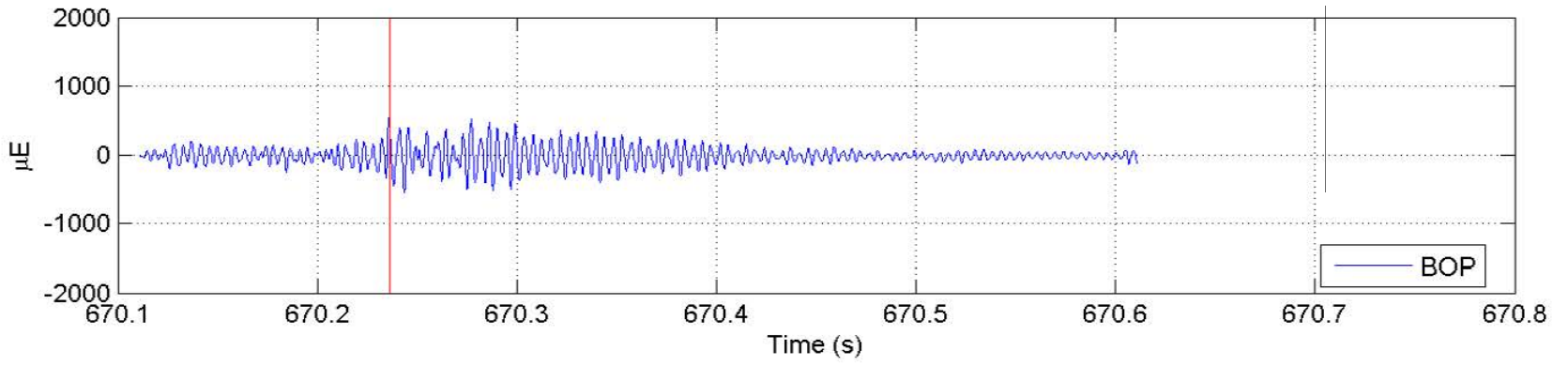
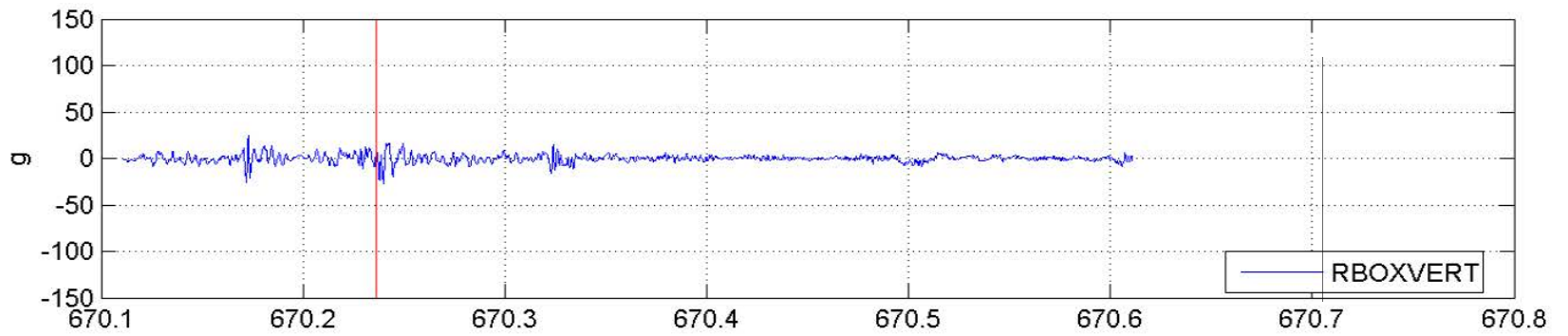
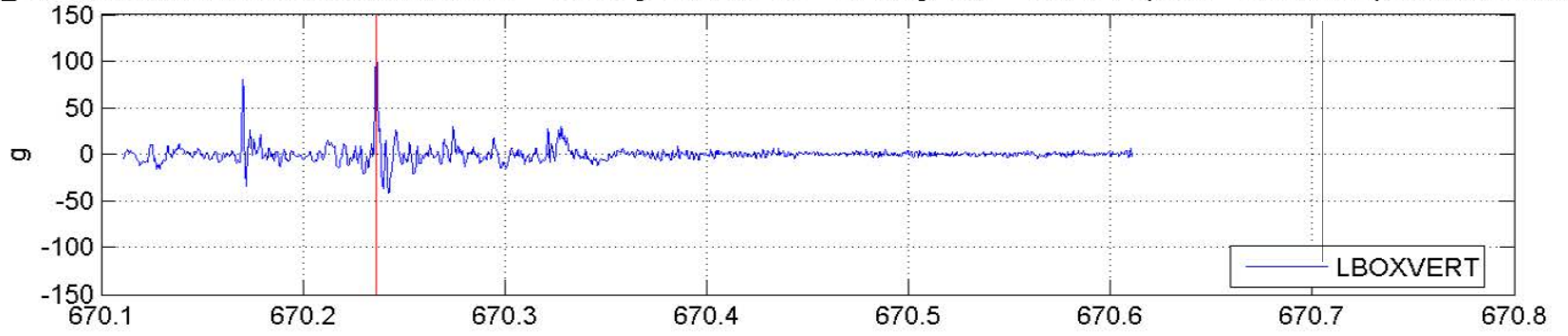

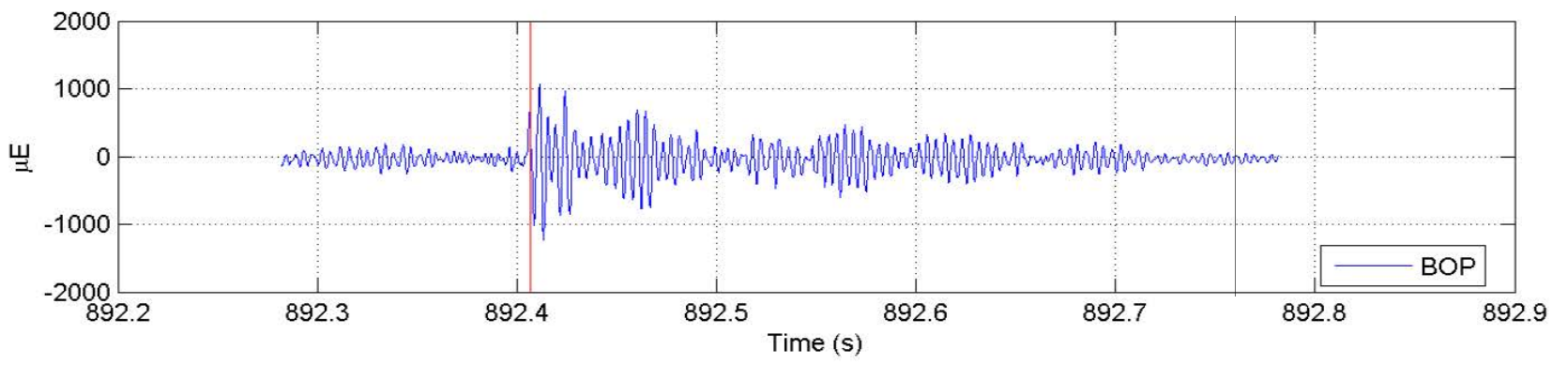
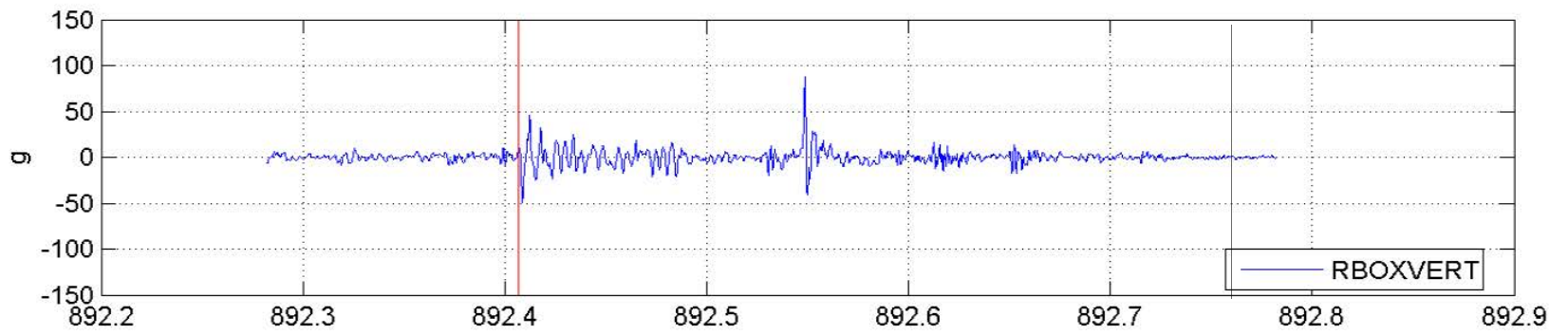
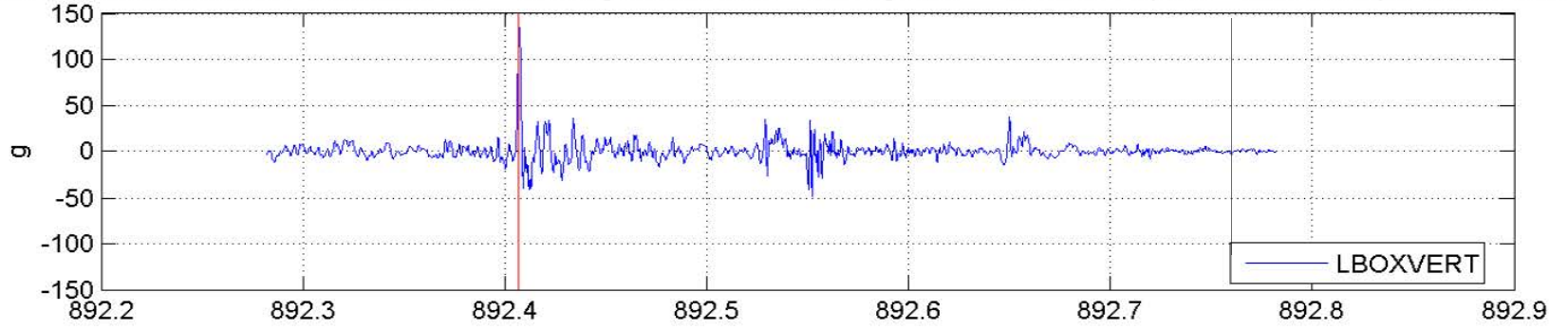

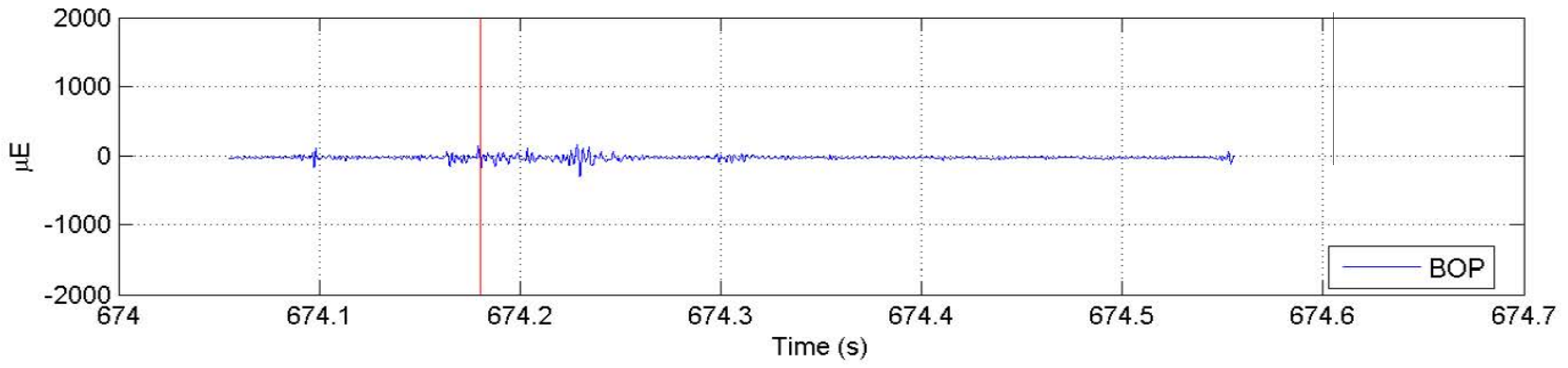
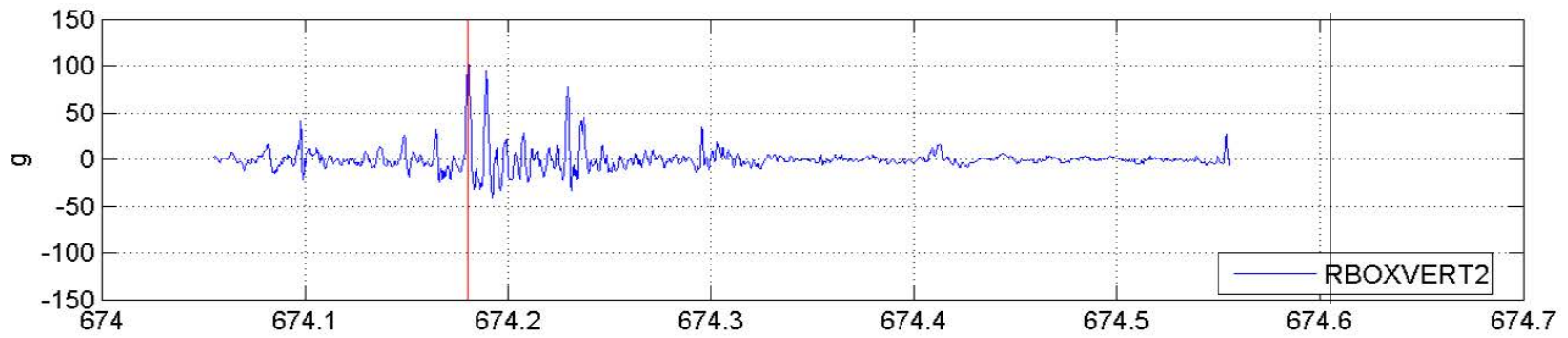
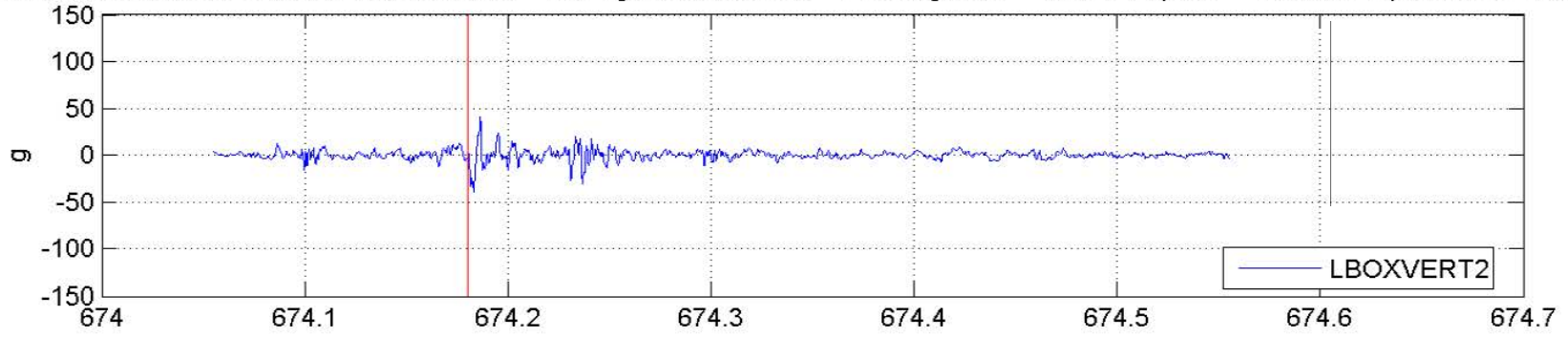

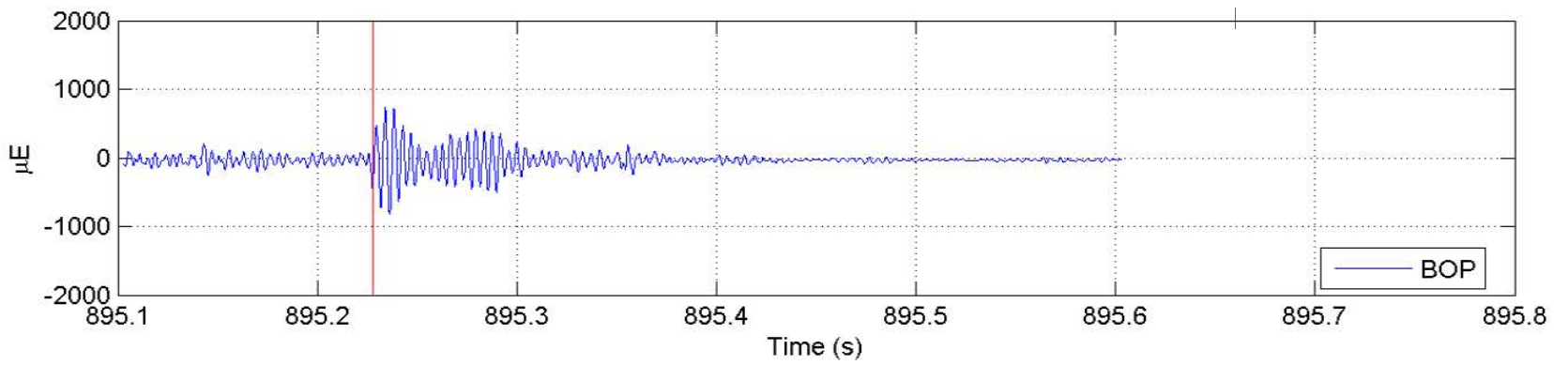
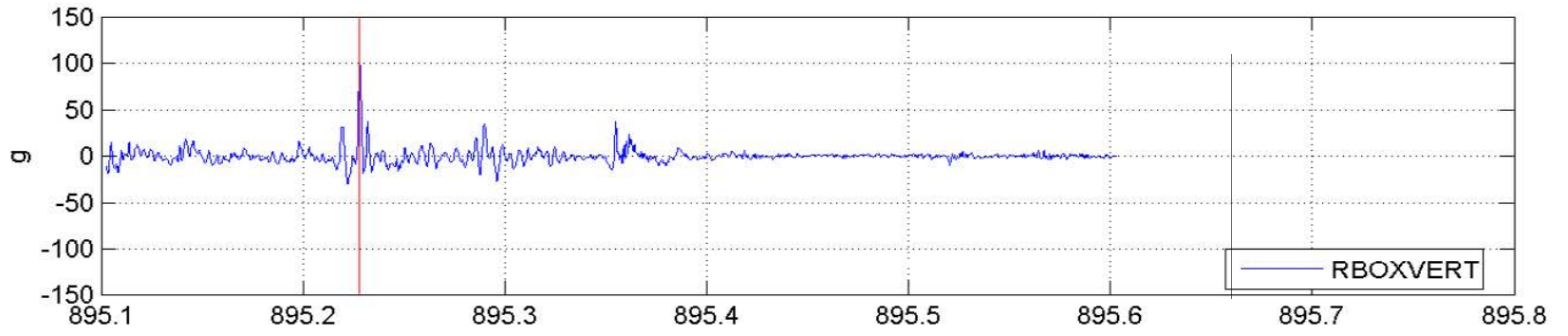
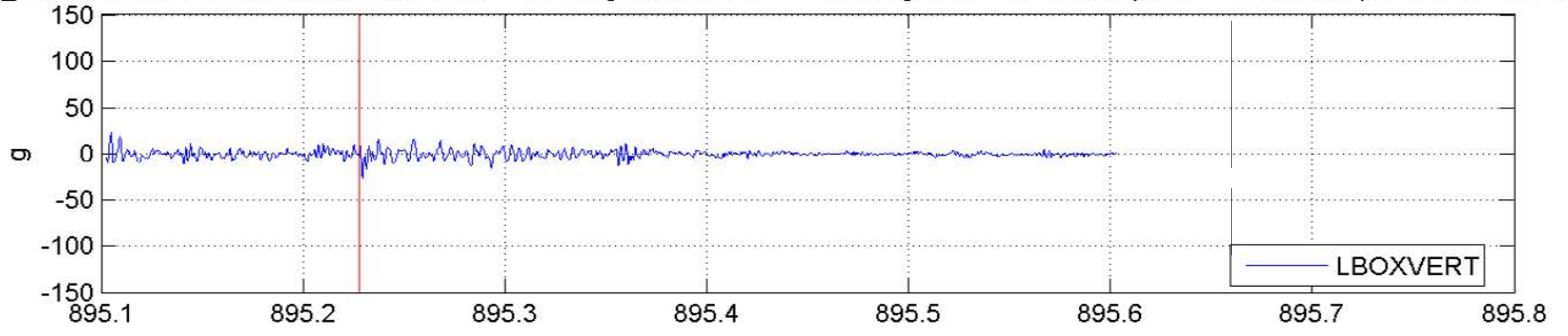

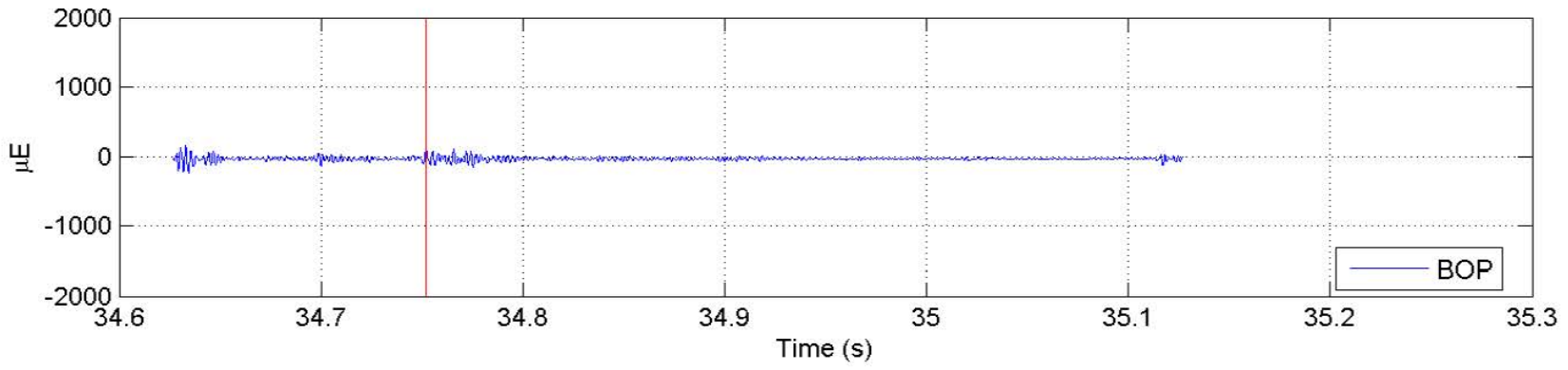
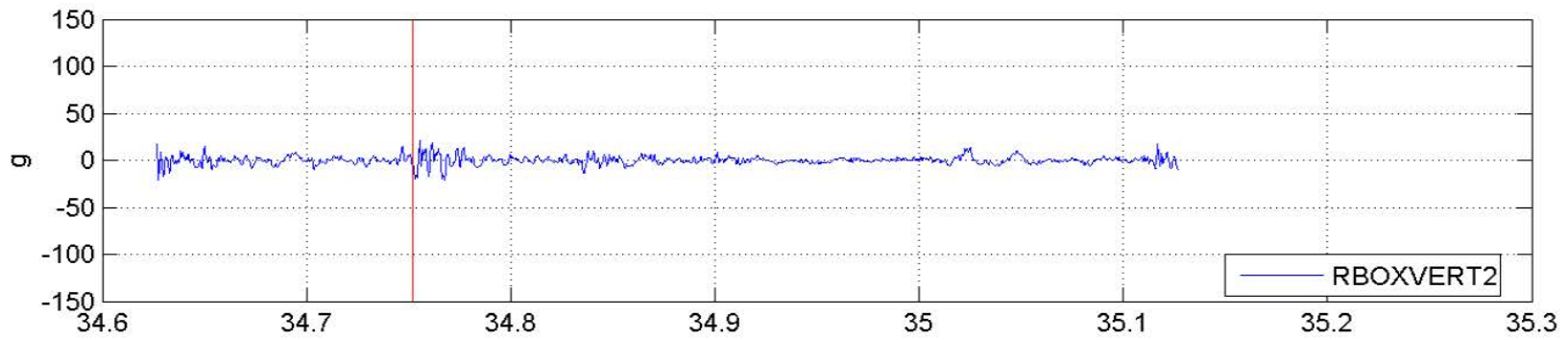
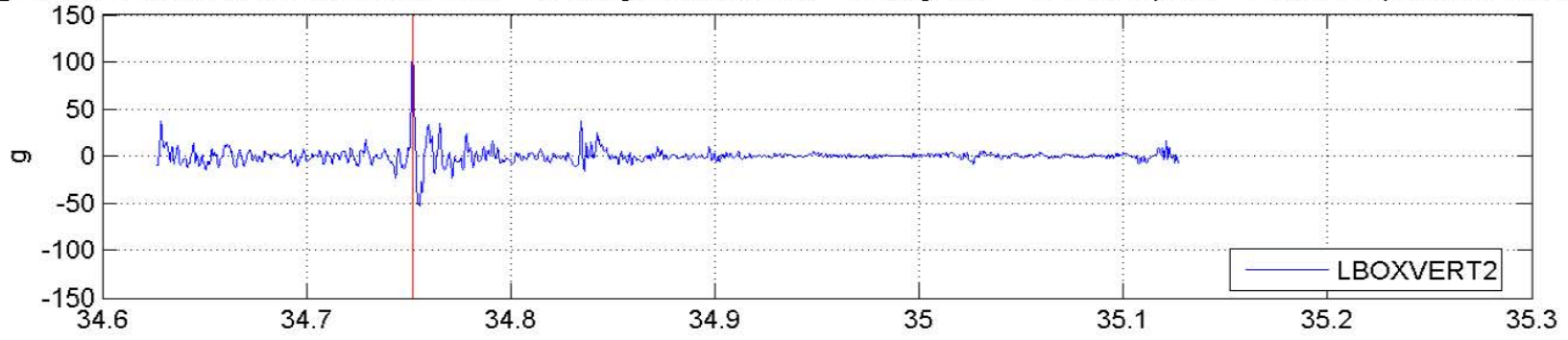

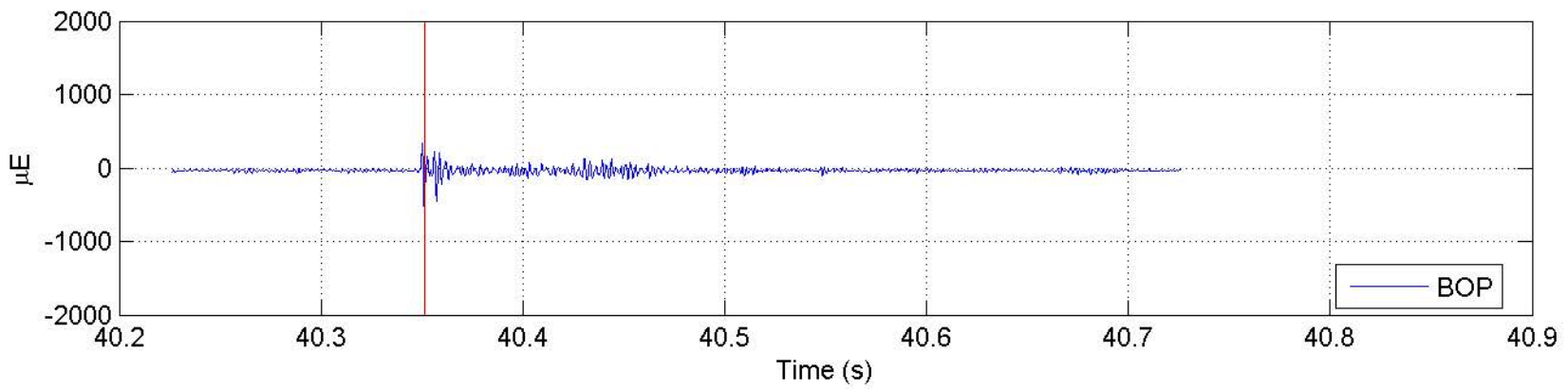
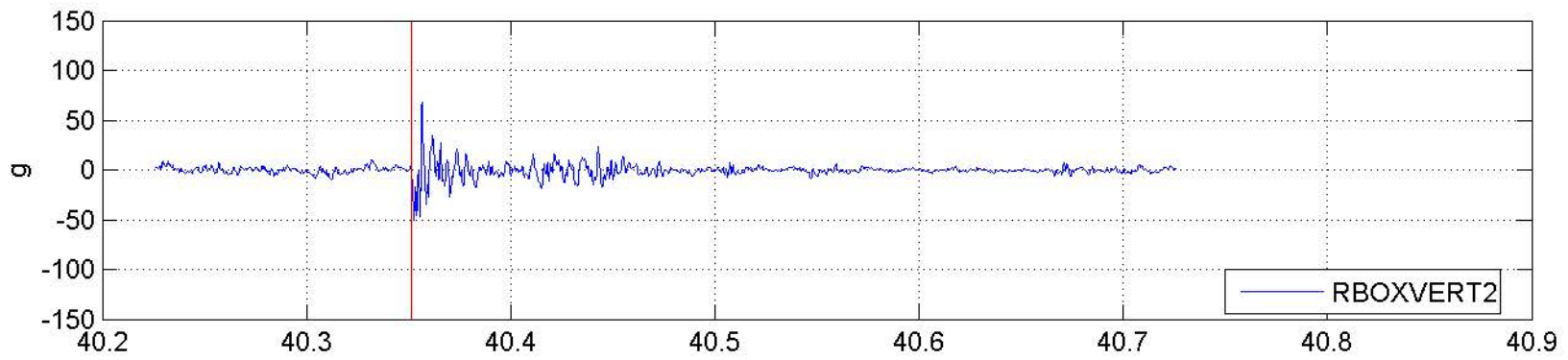
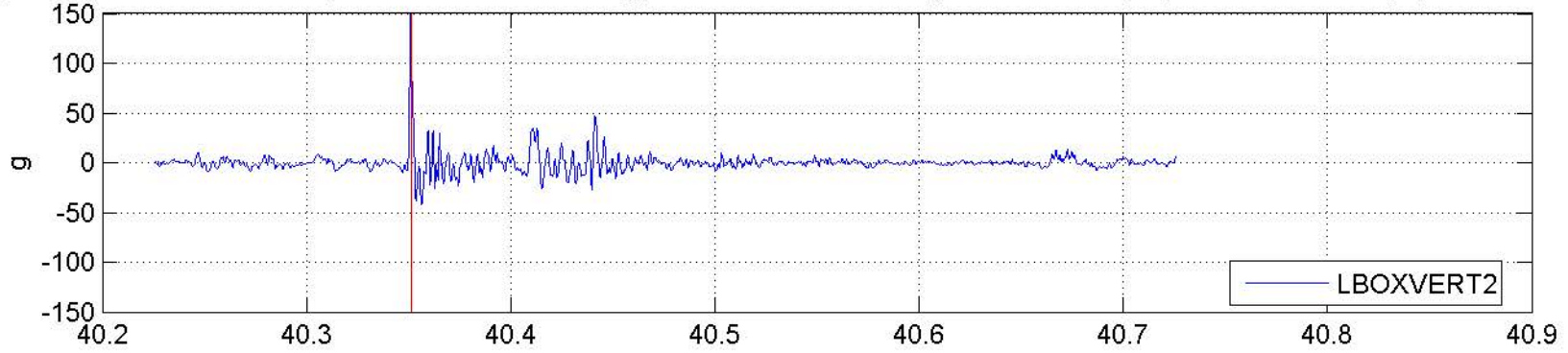

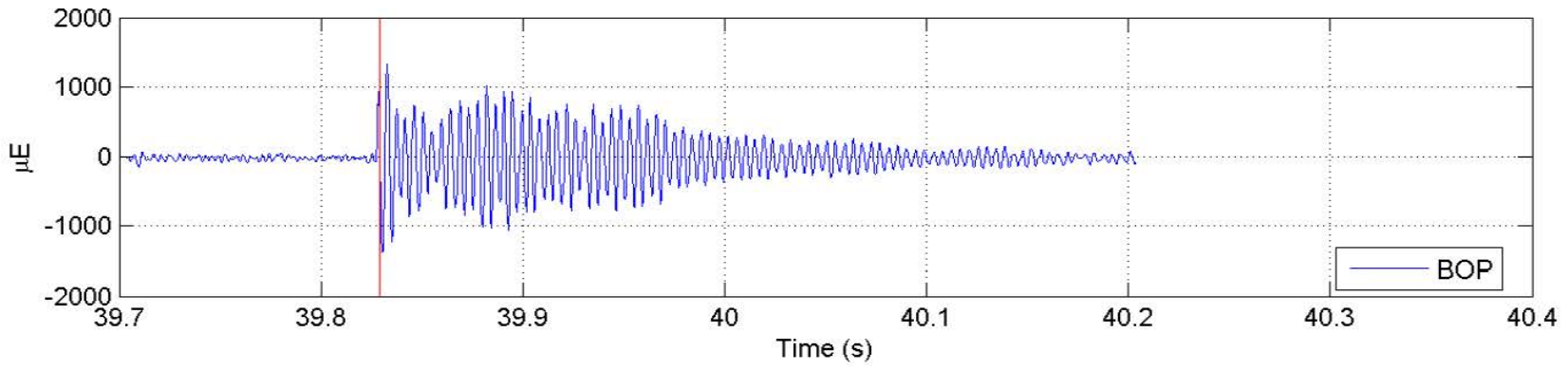
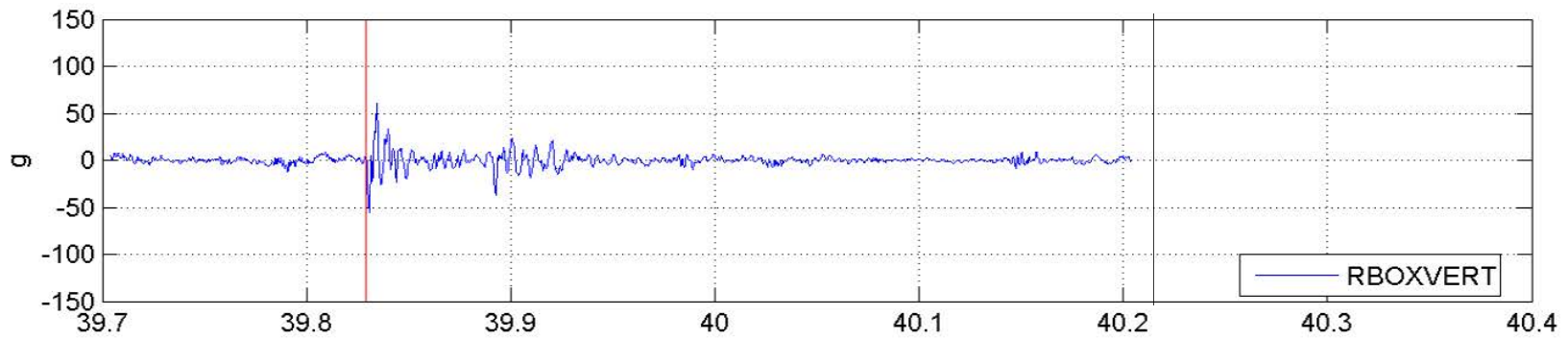
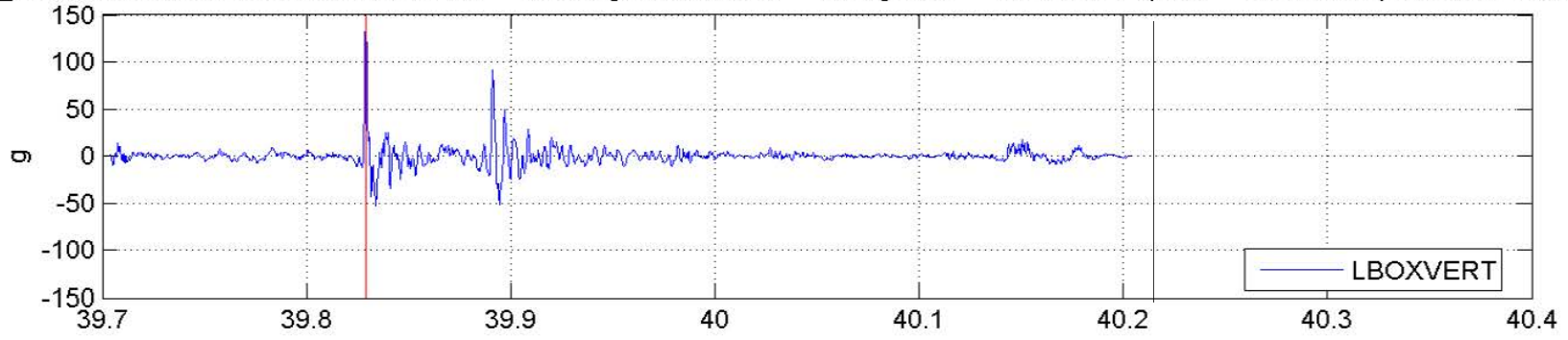

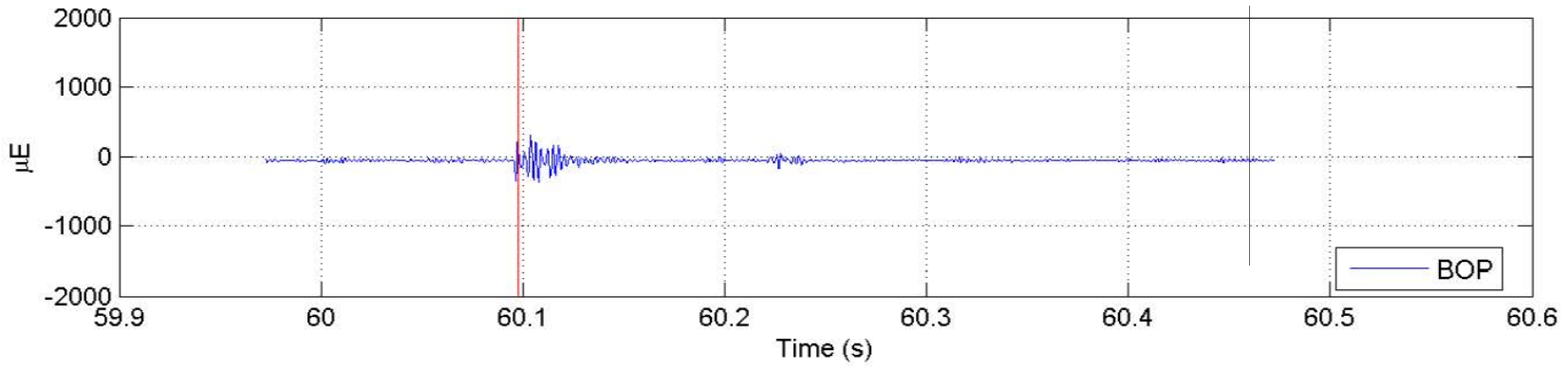
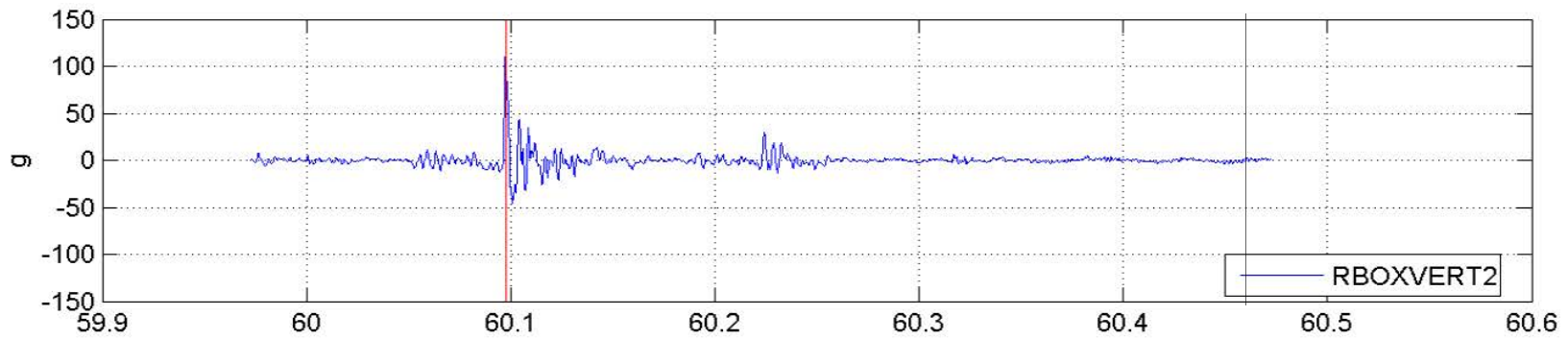
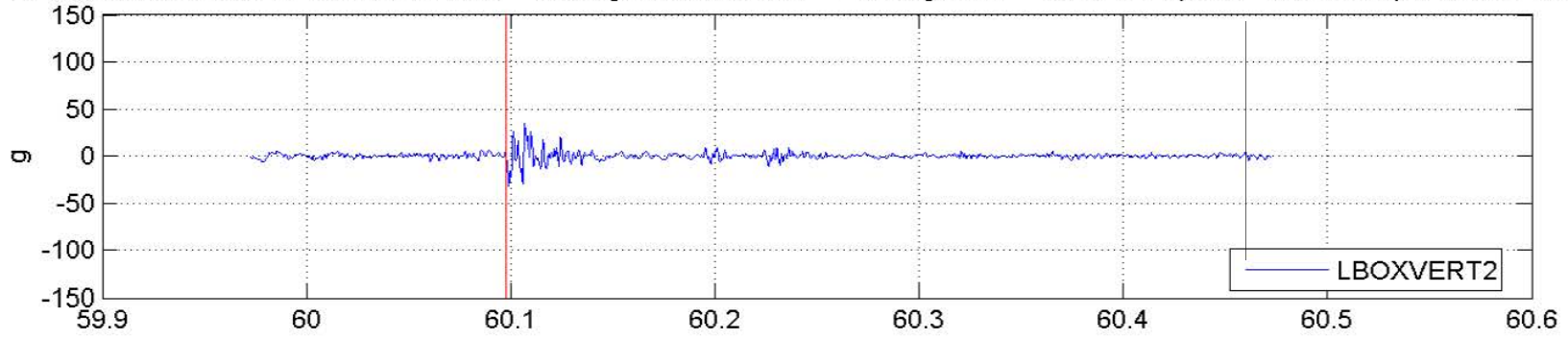

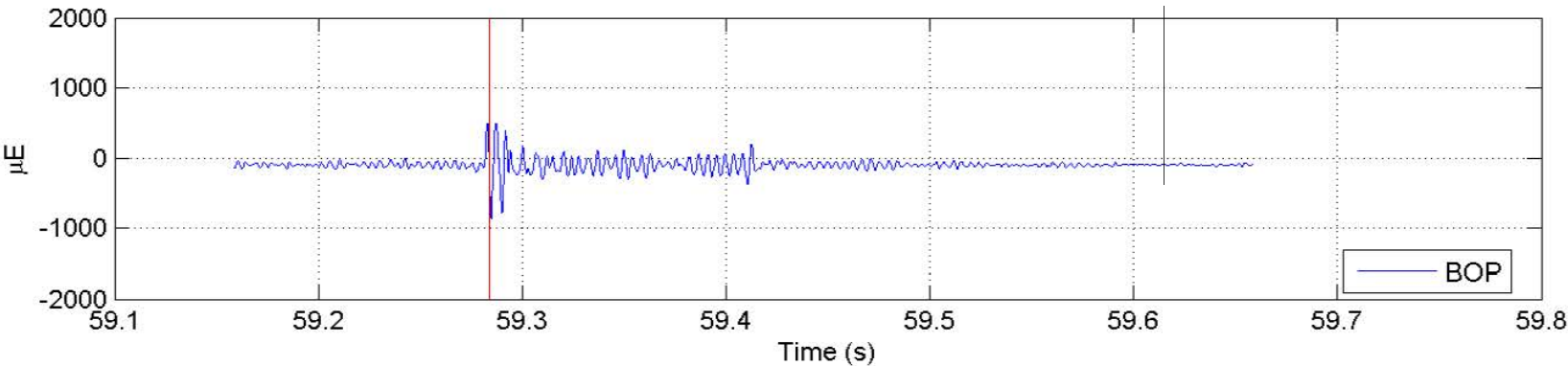
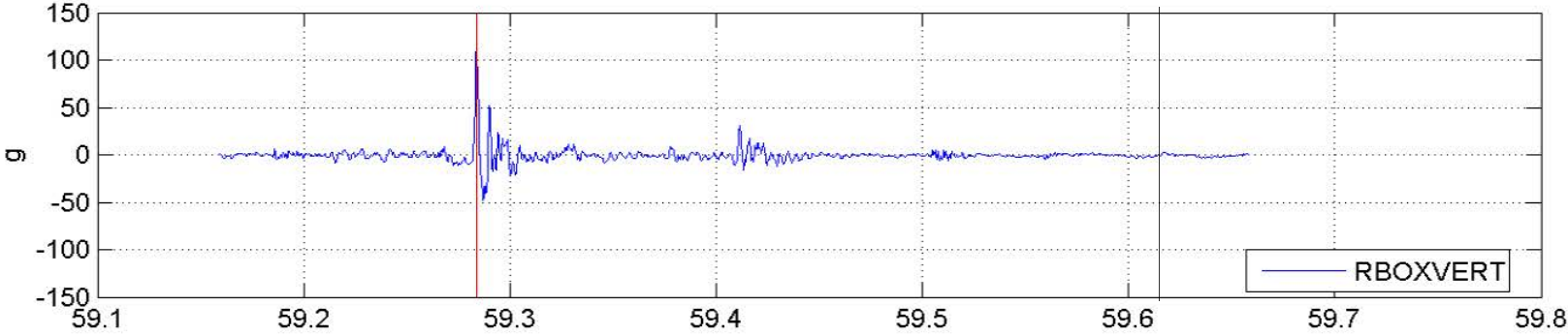
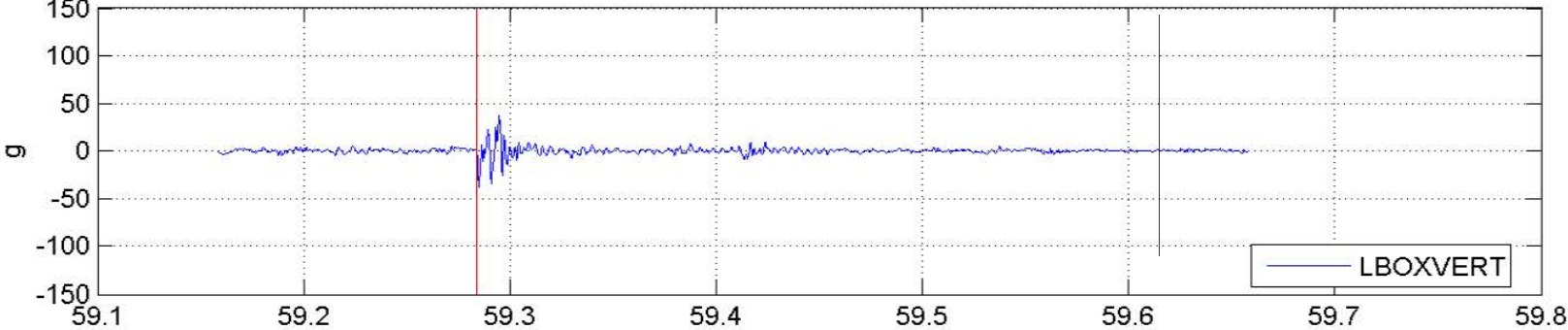

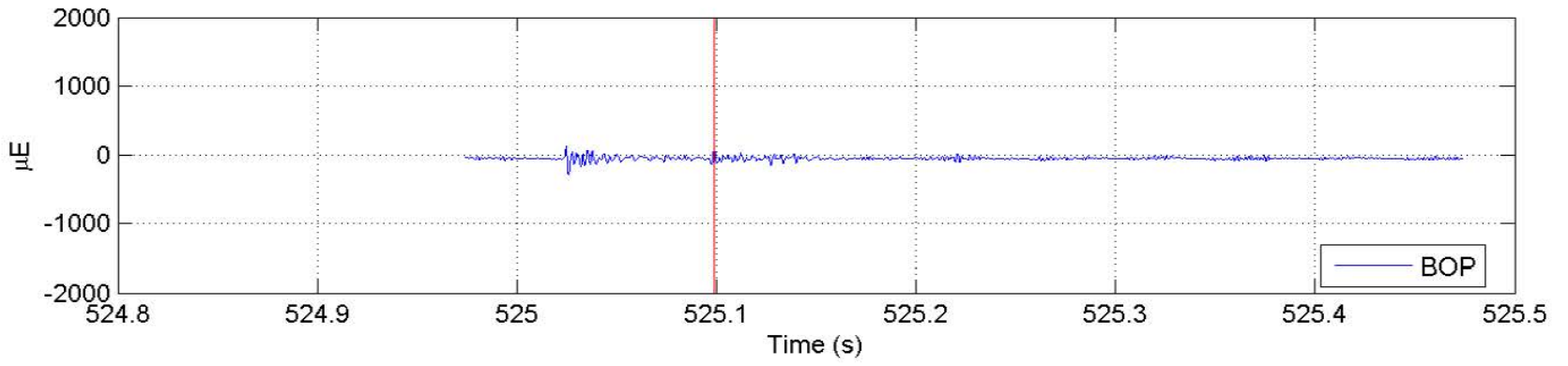
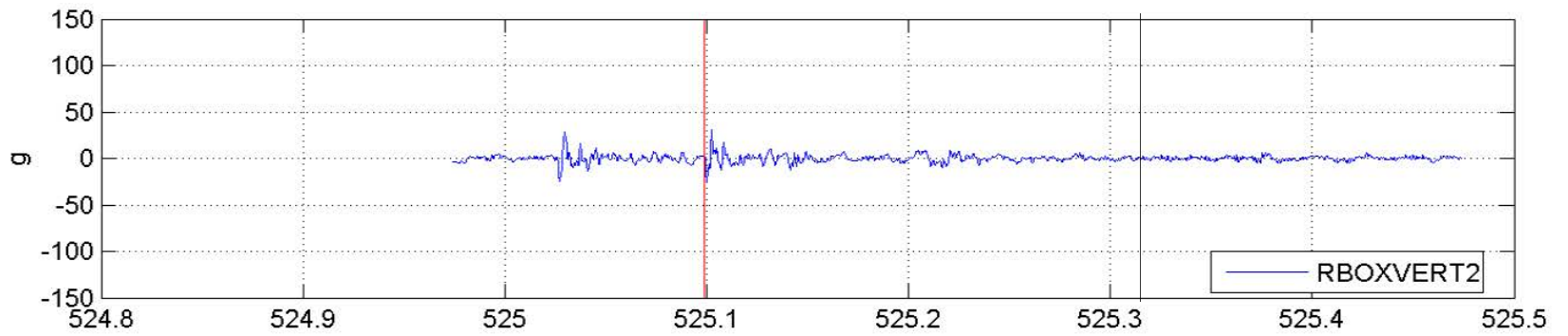
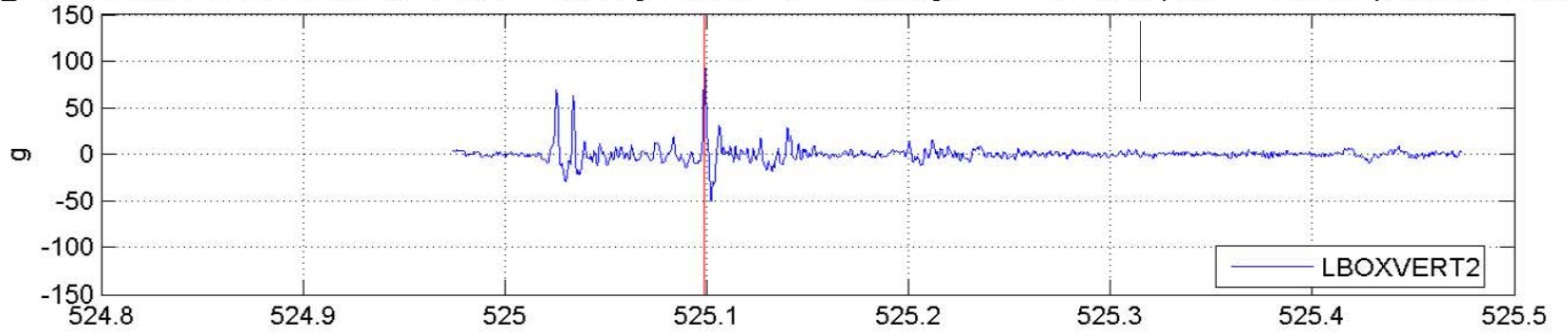

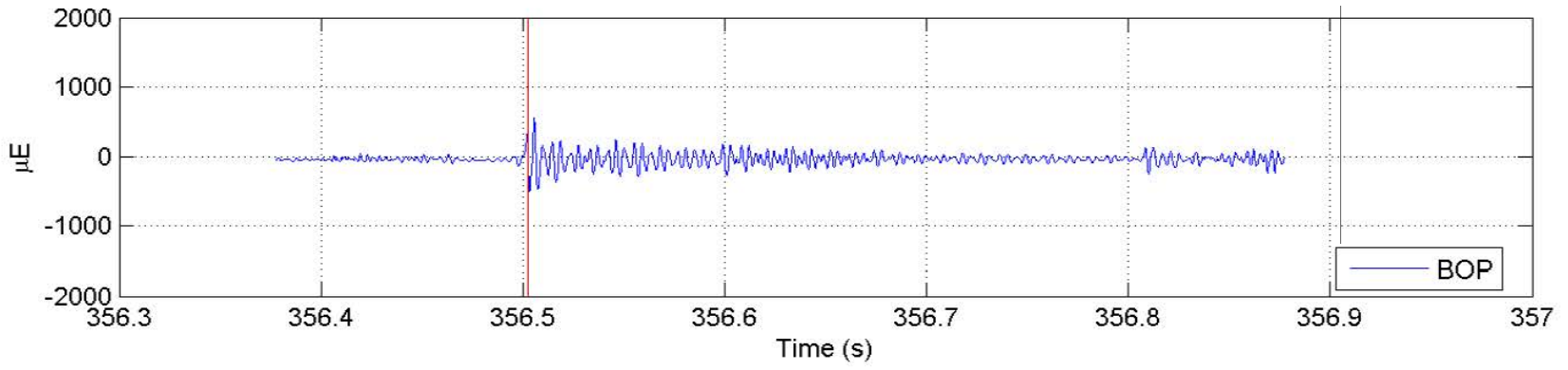
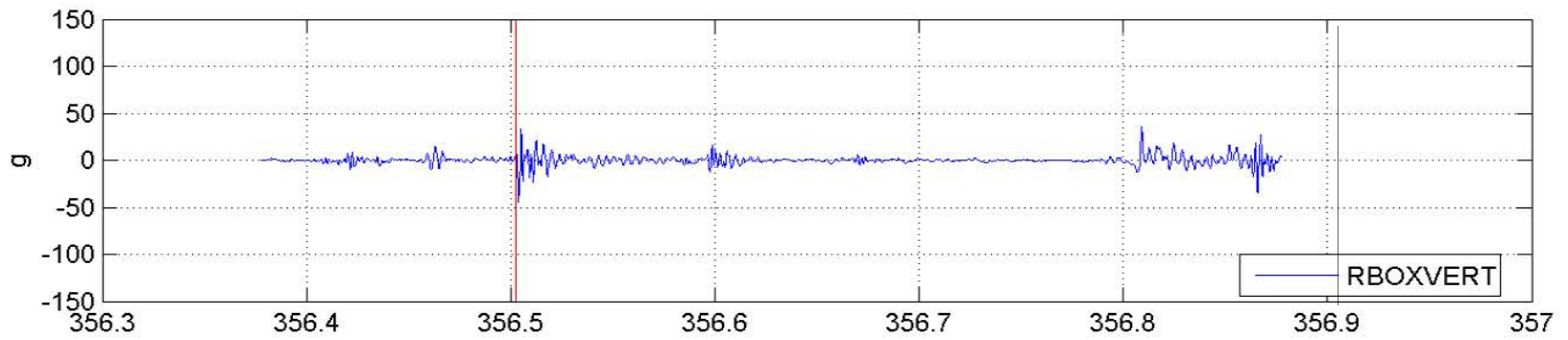
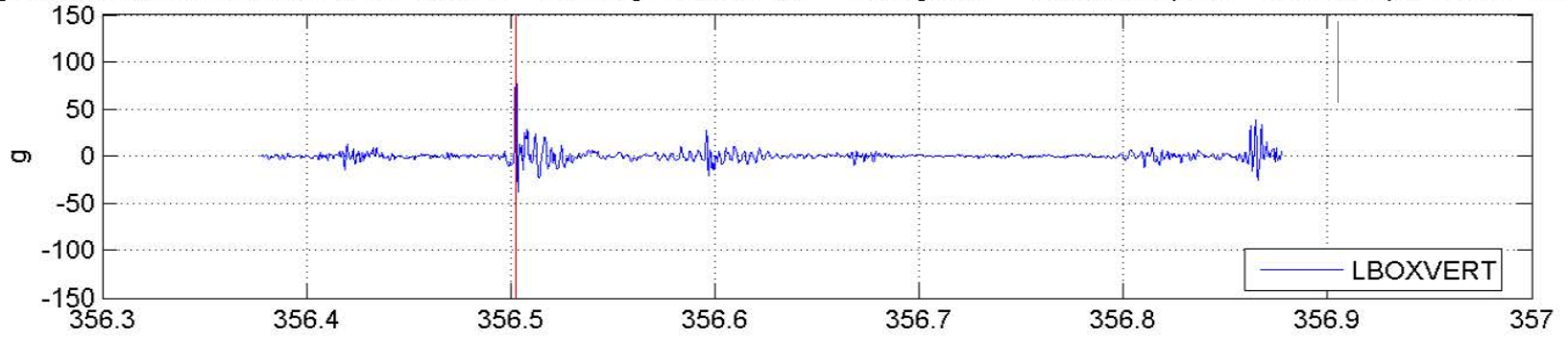

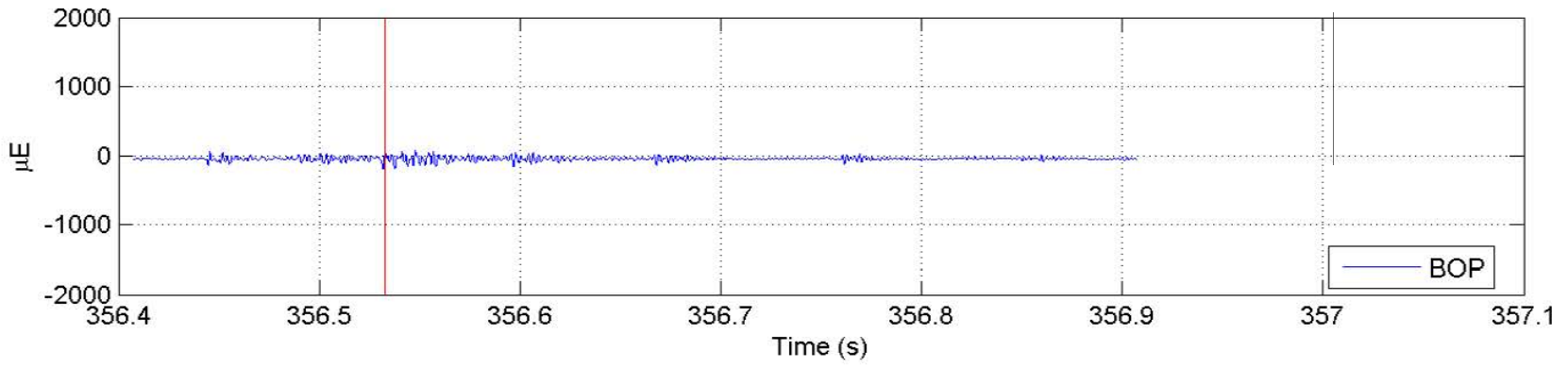
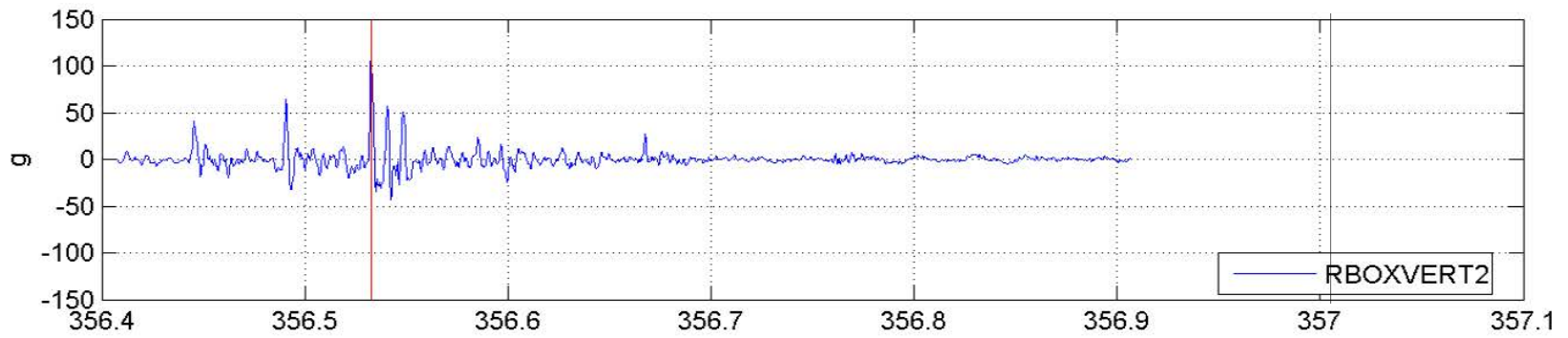
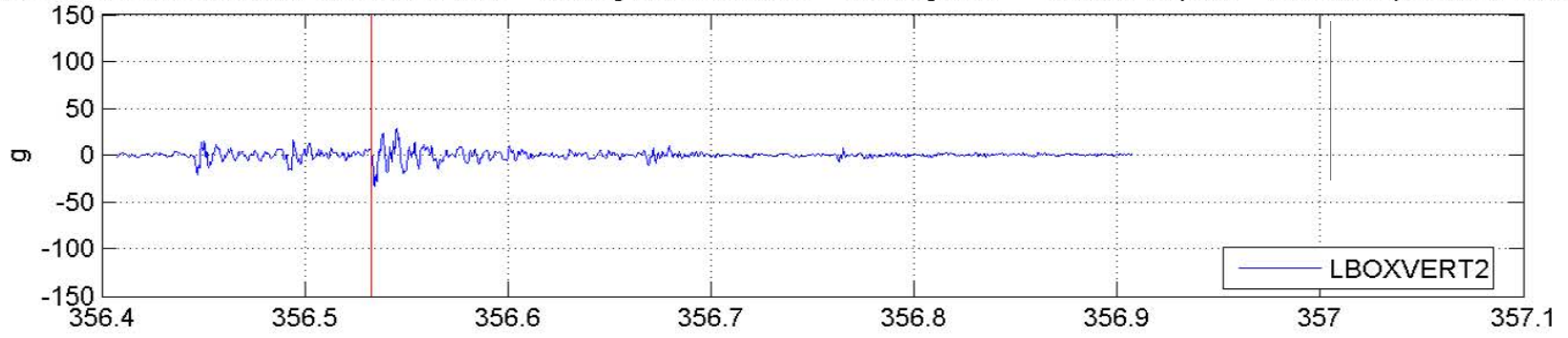

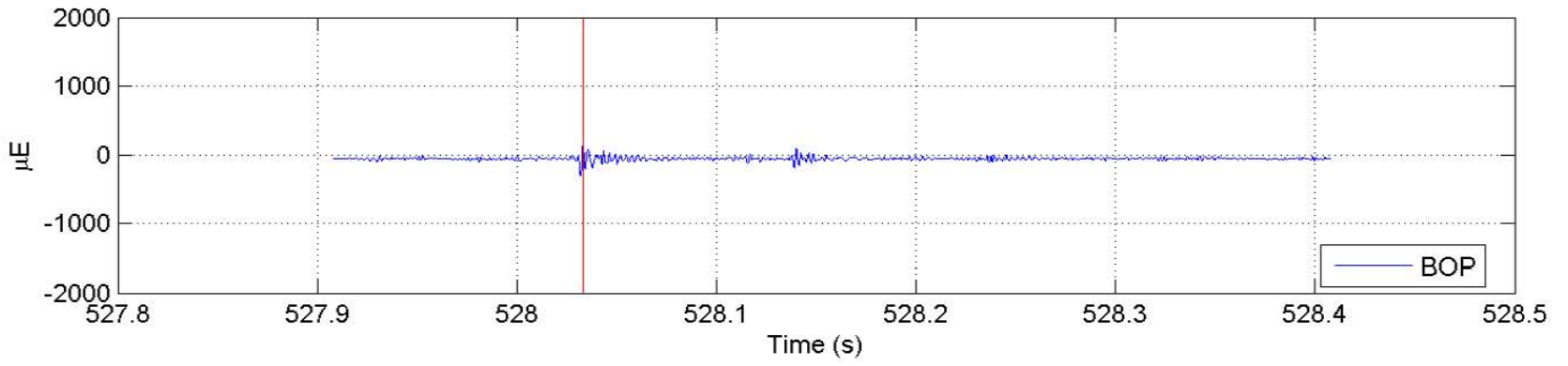
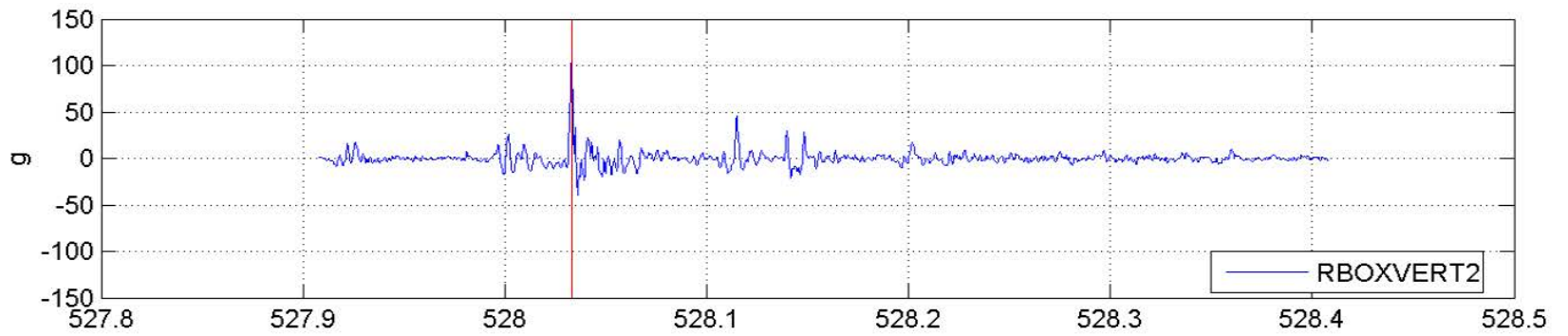
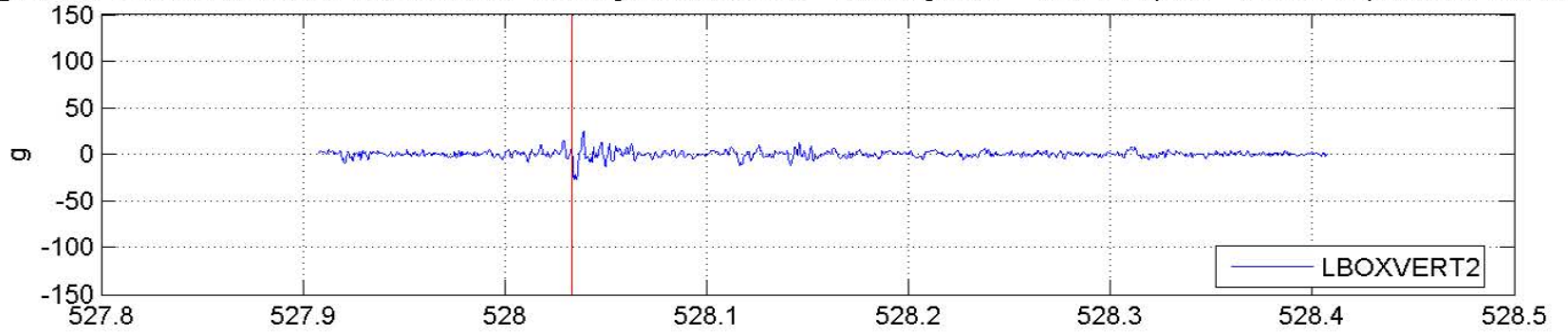

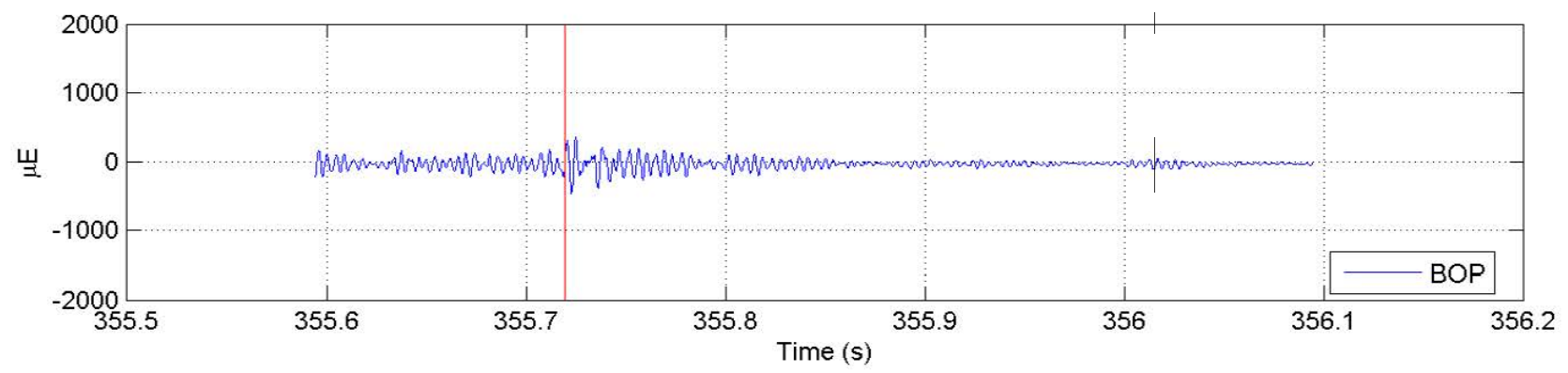
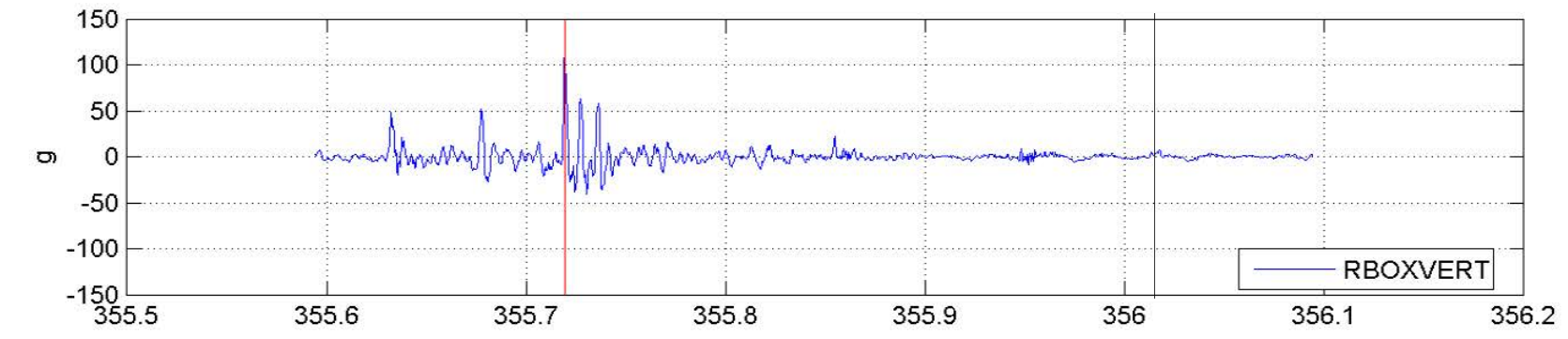
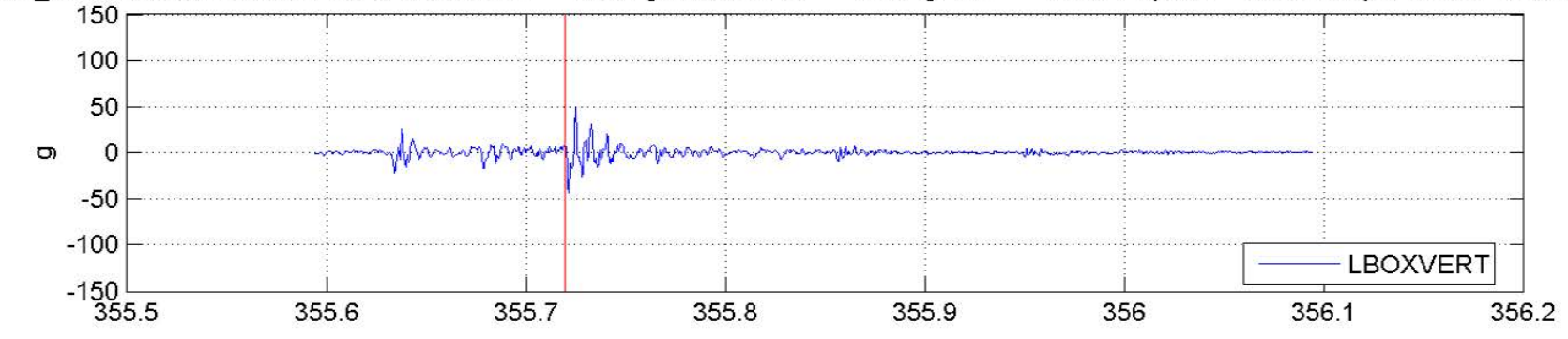

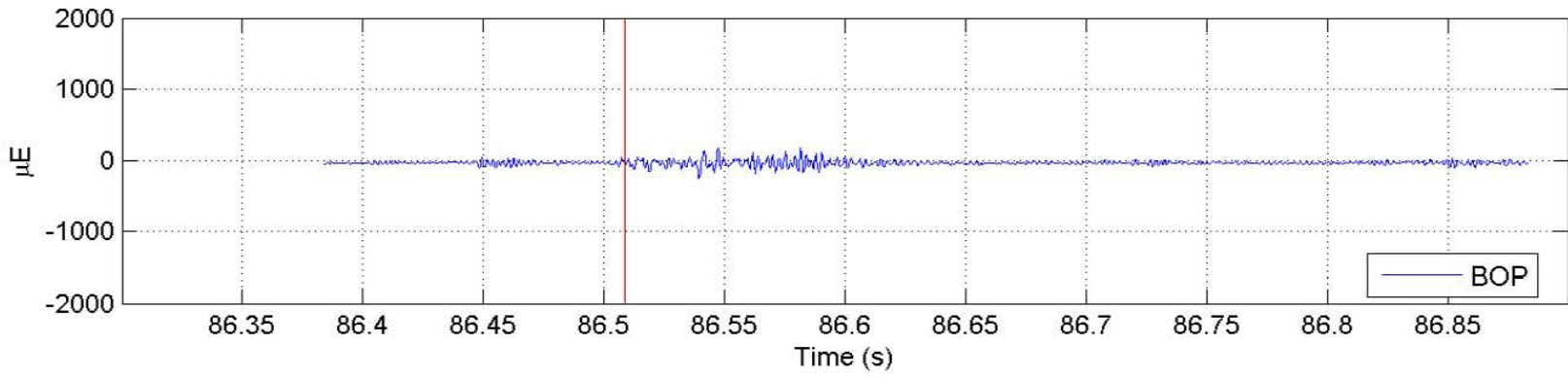
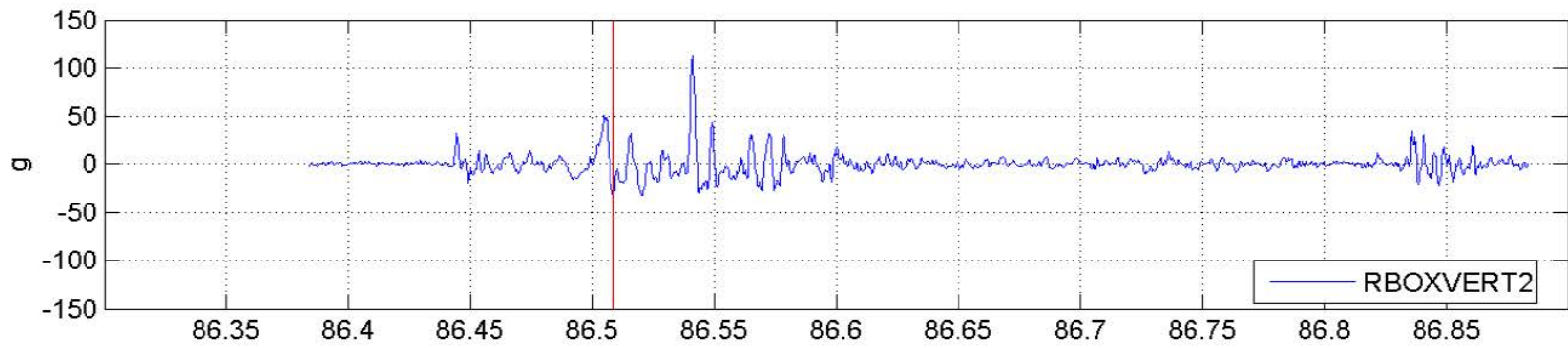
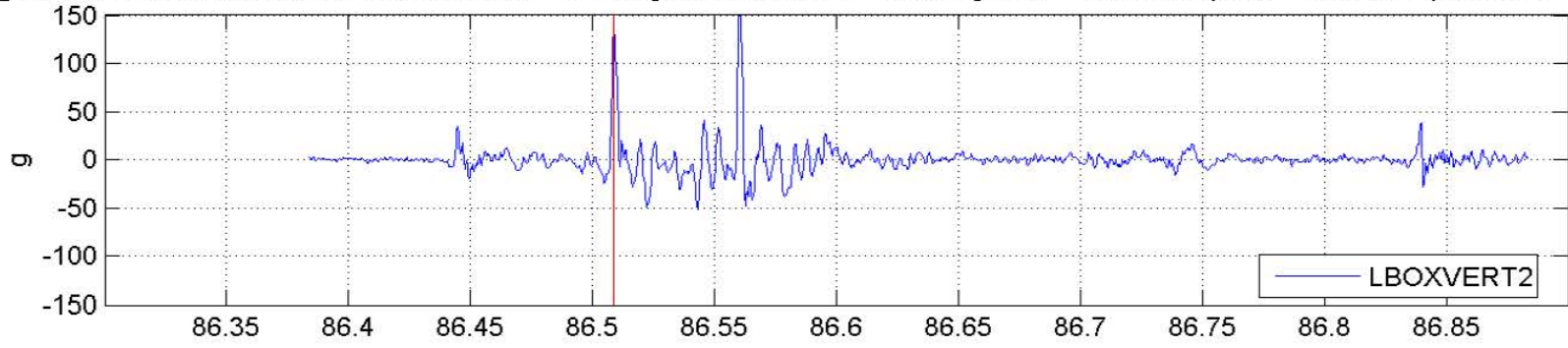

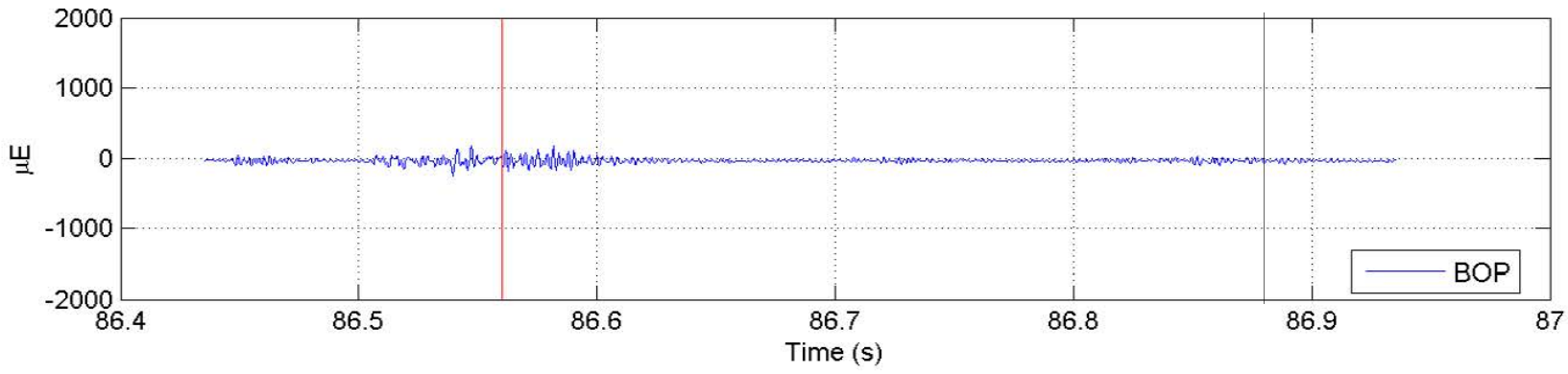
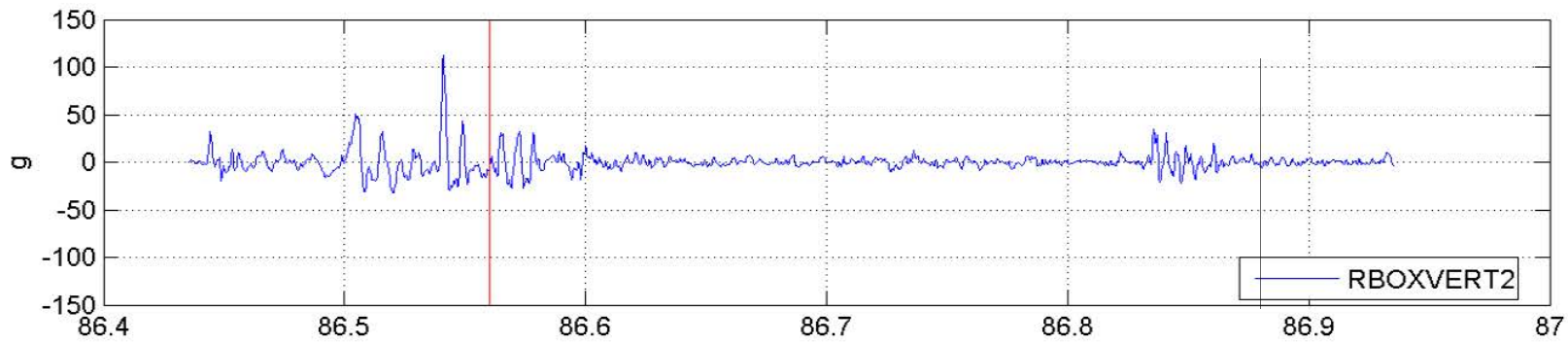
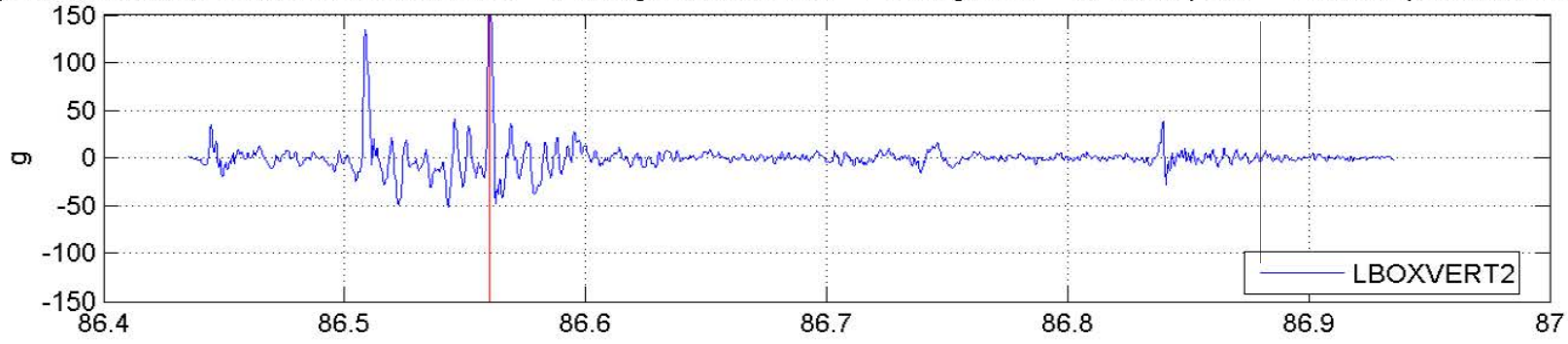

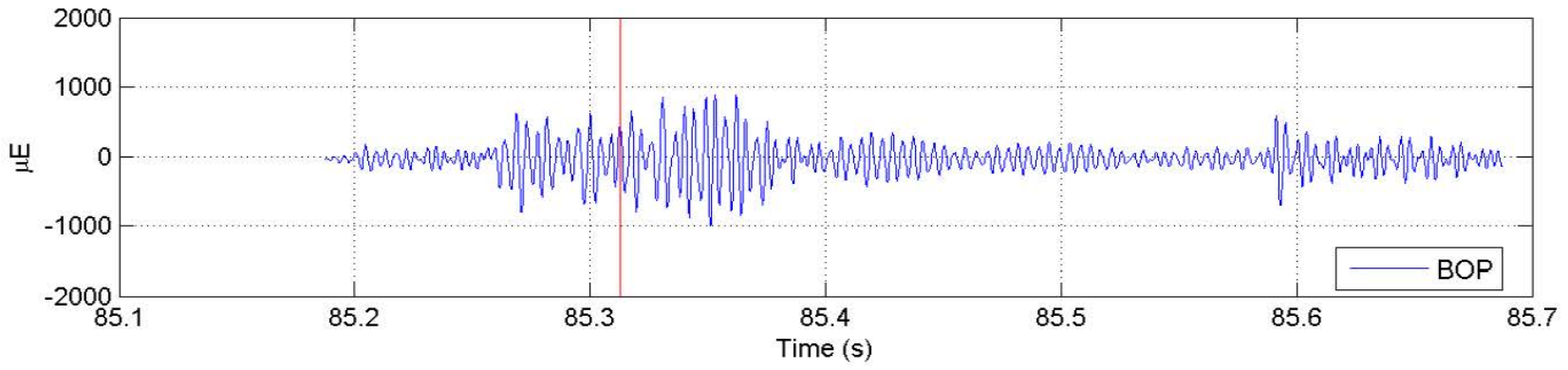
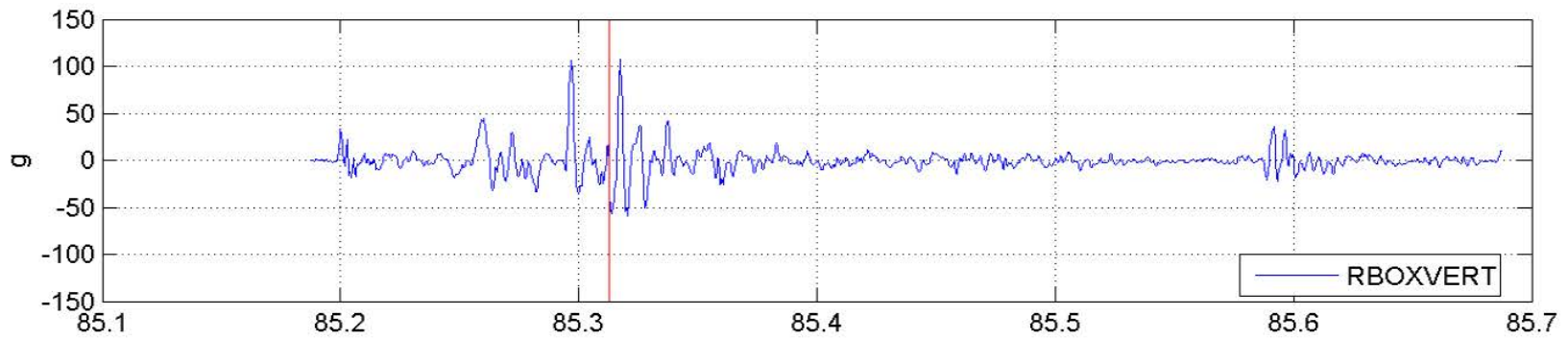
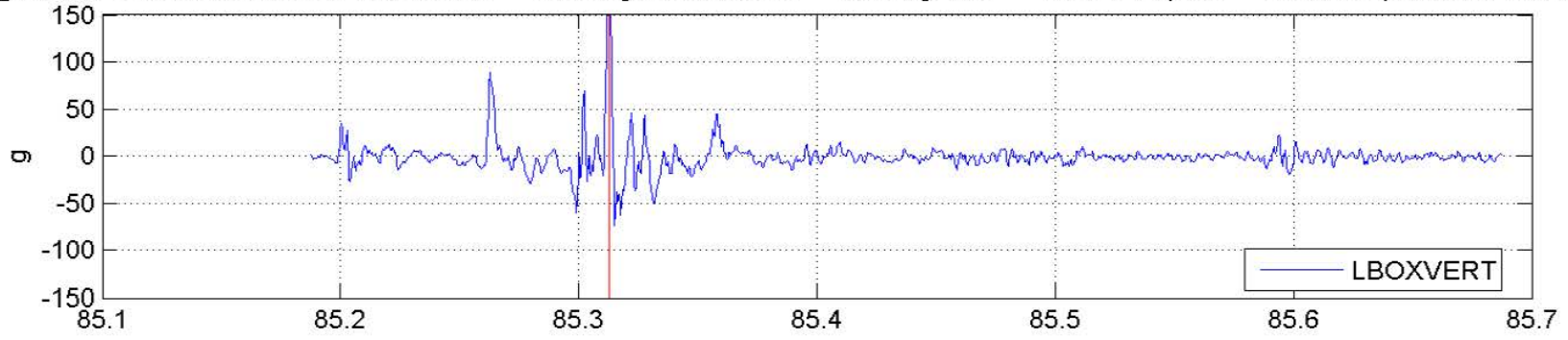

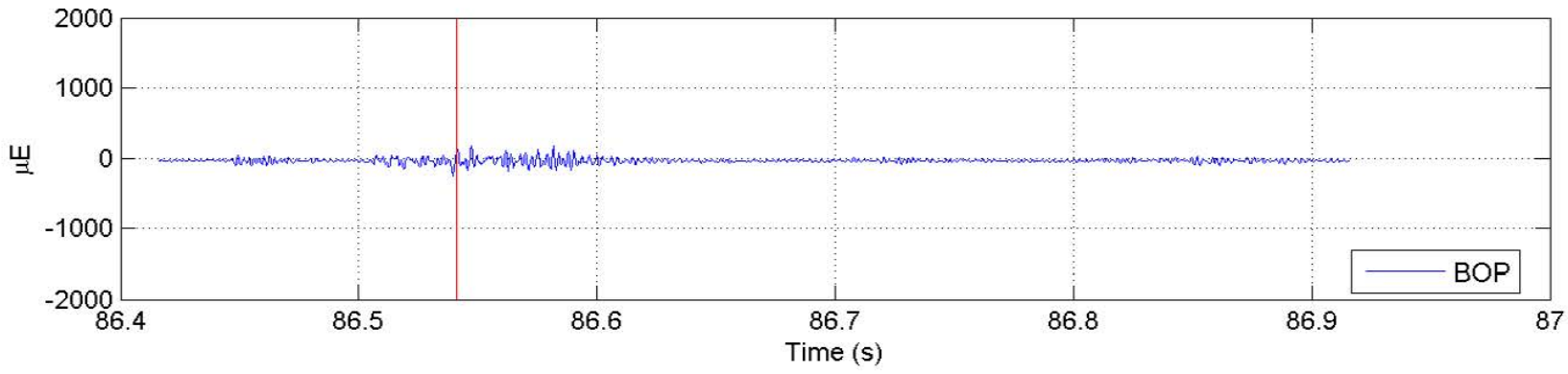
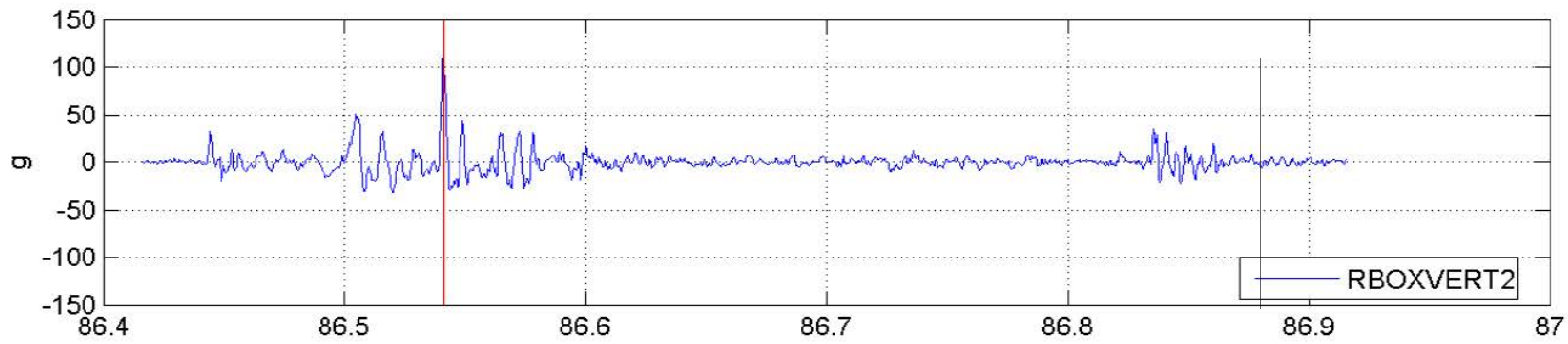
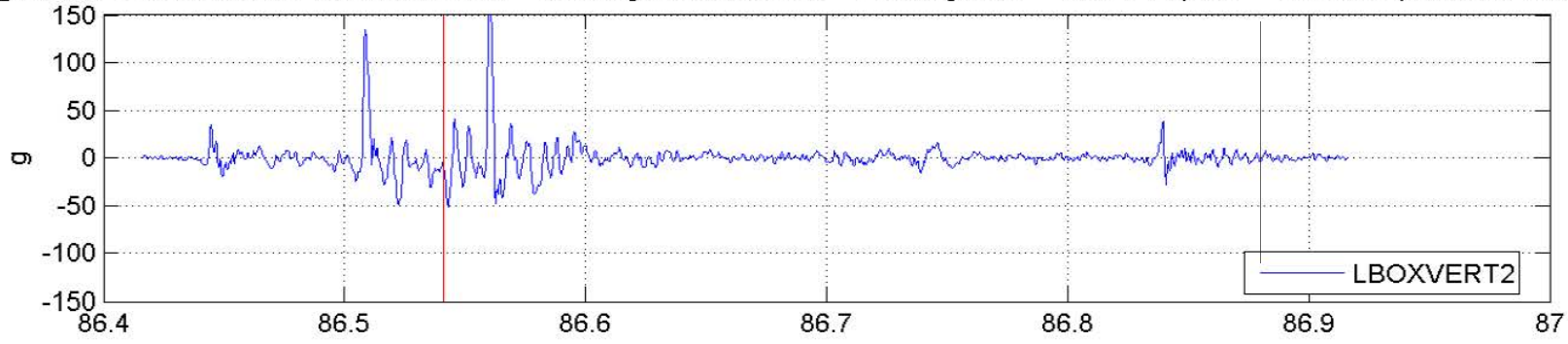

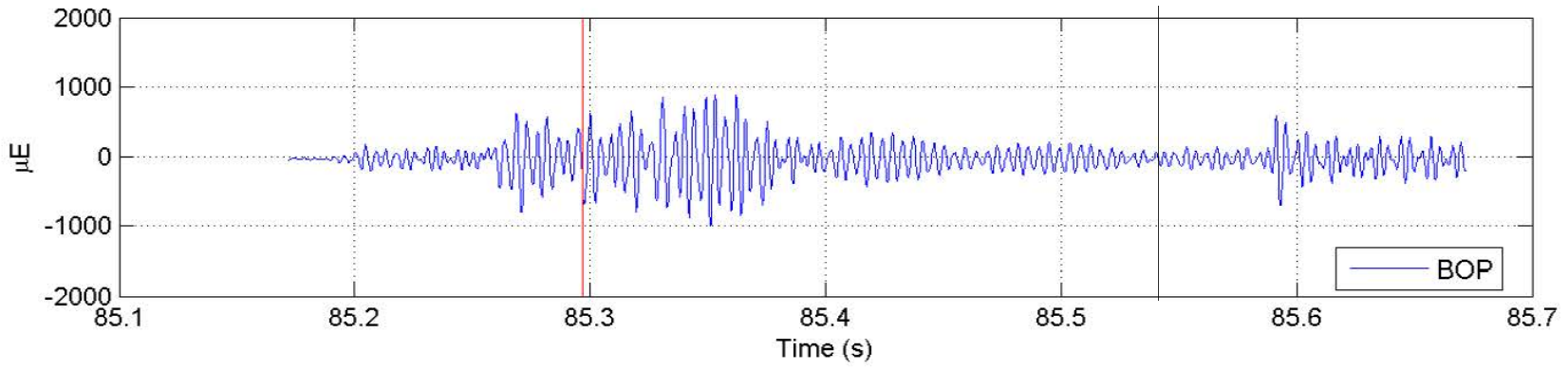
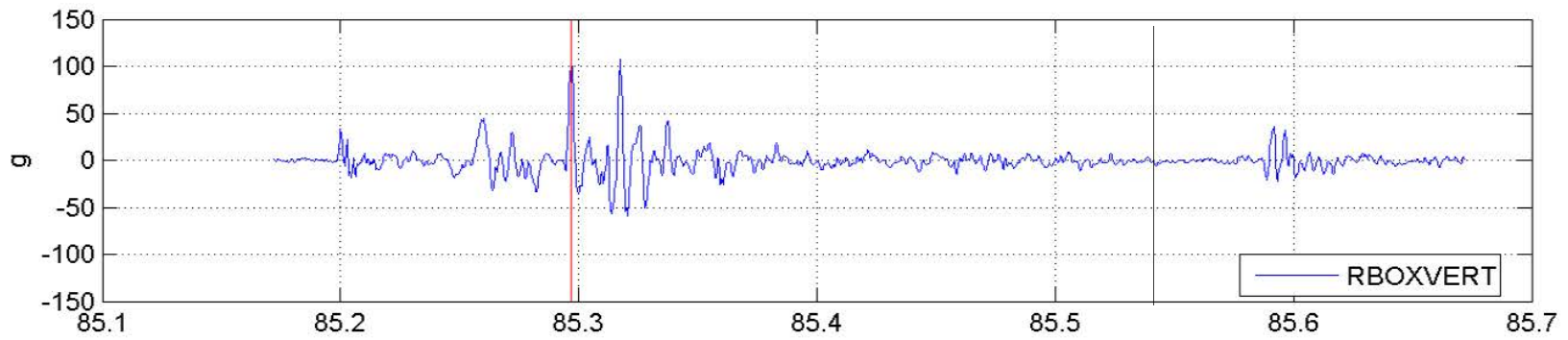
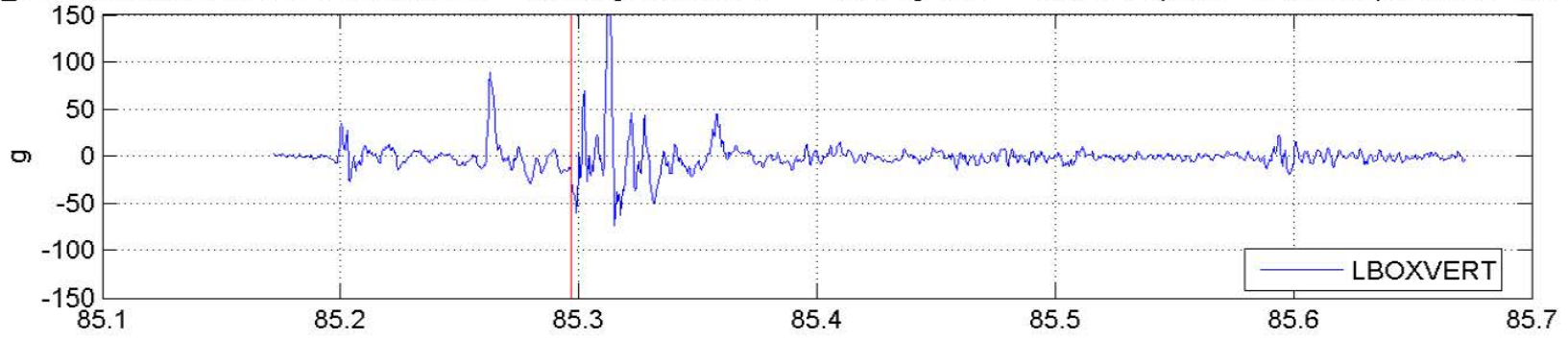

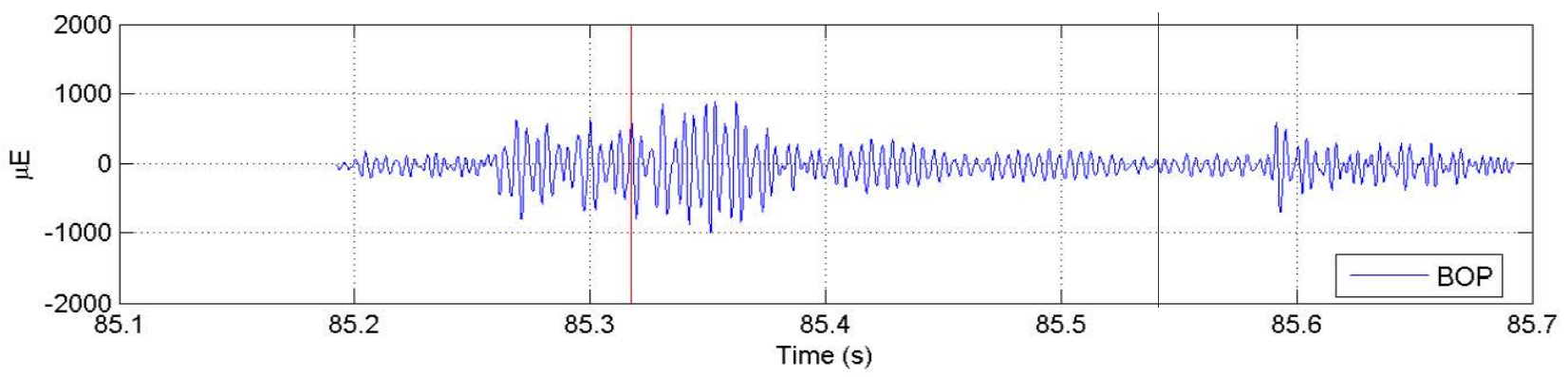
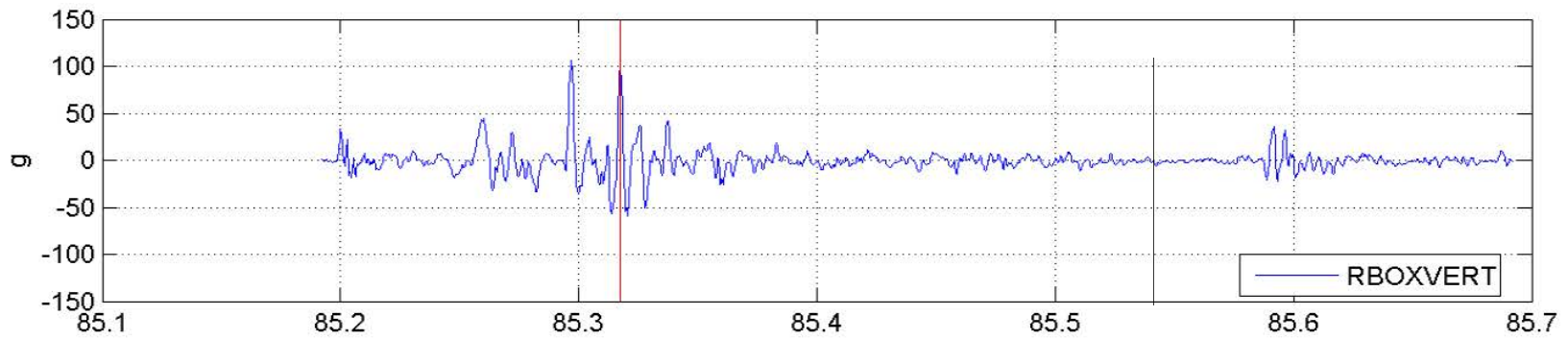
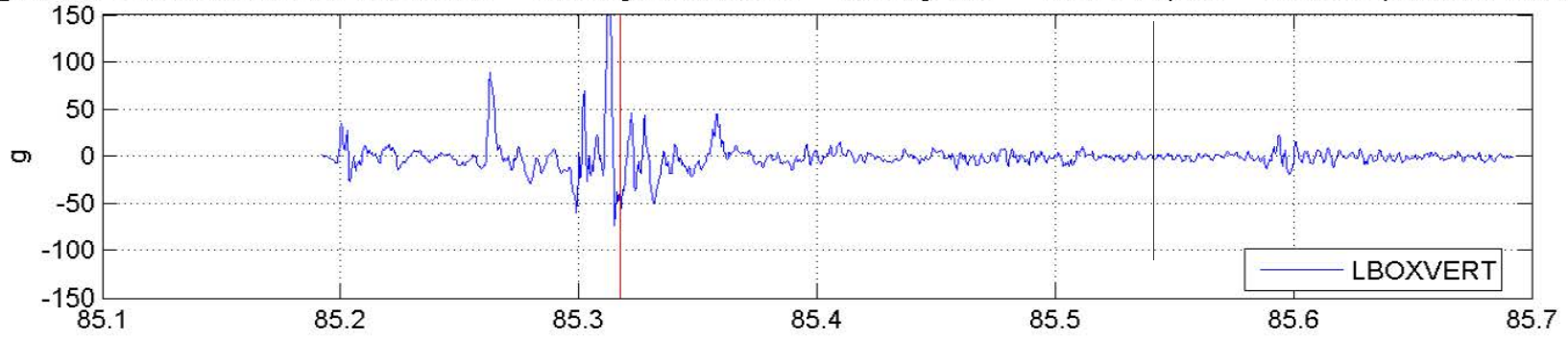

Day 7–June 18, 2005

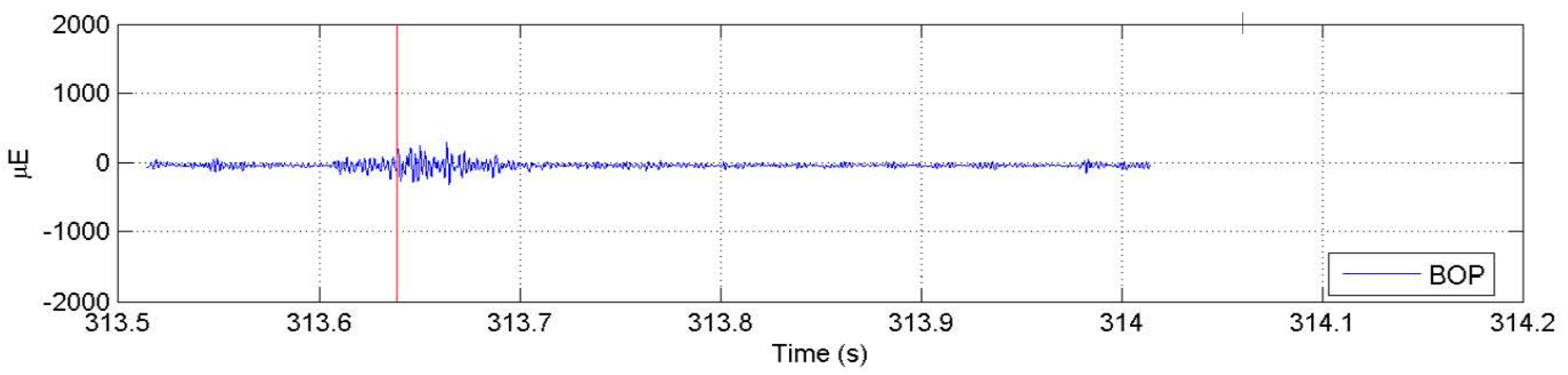
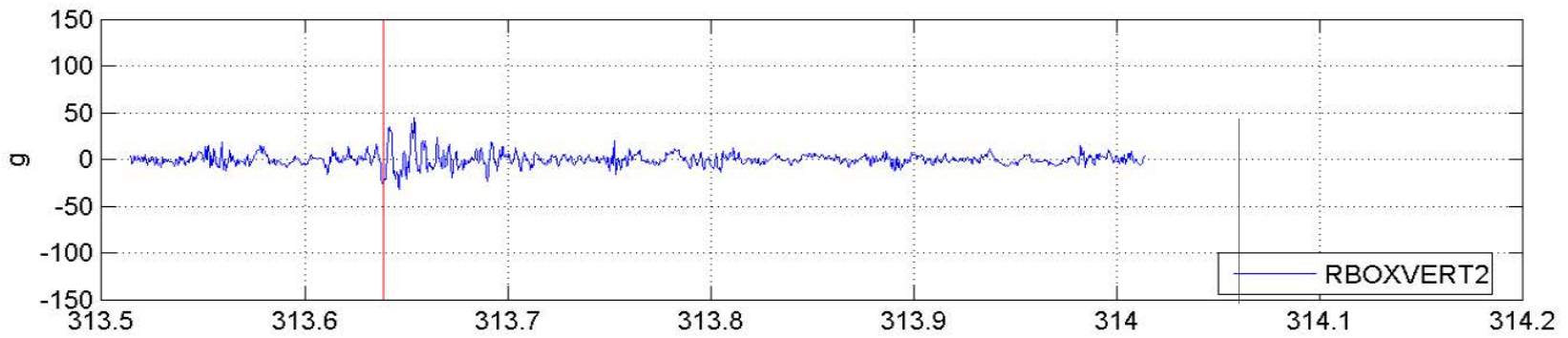
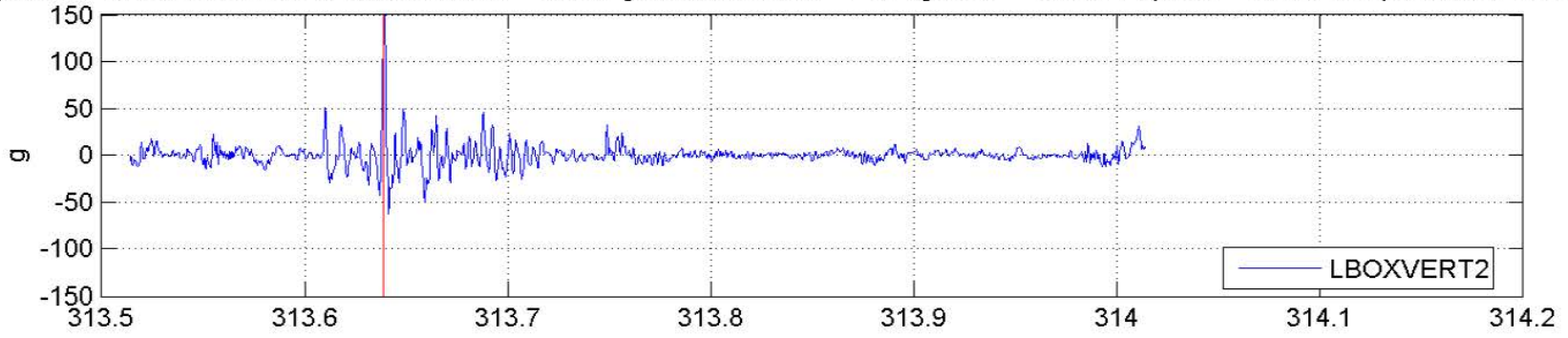

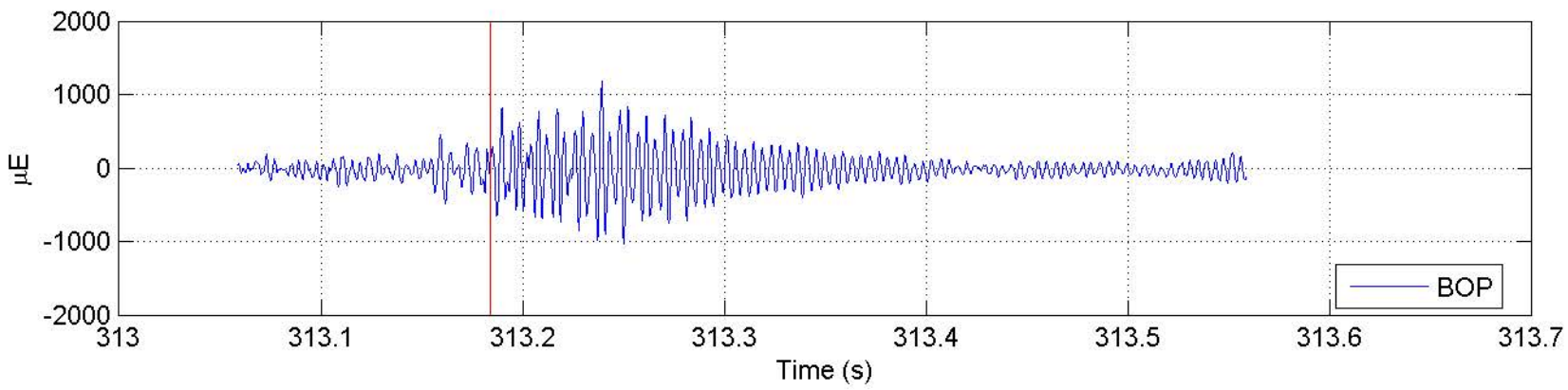
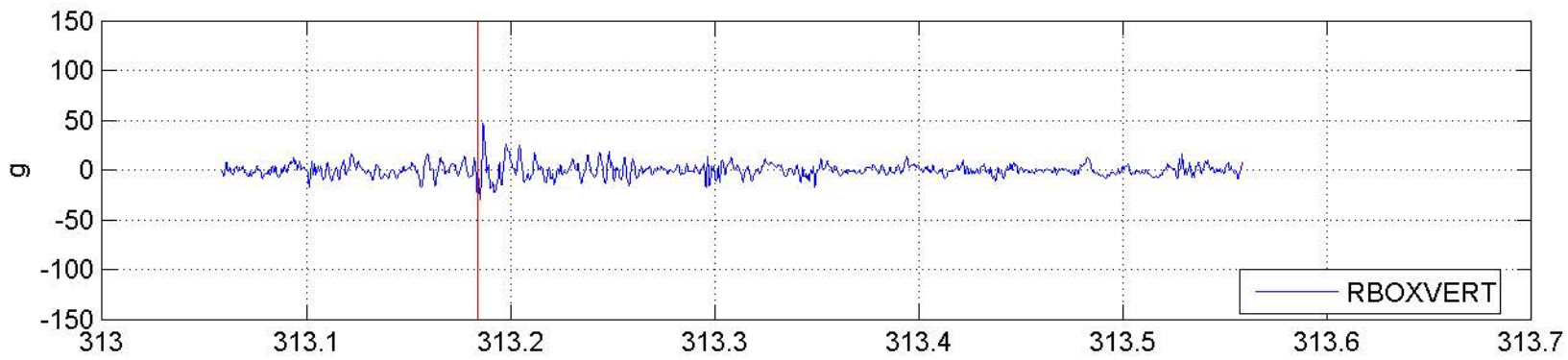
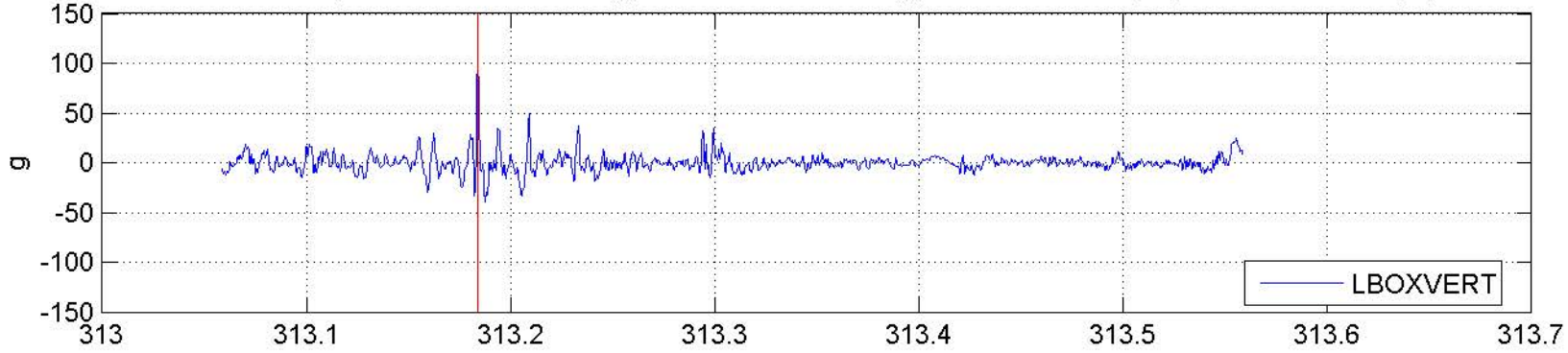

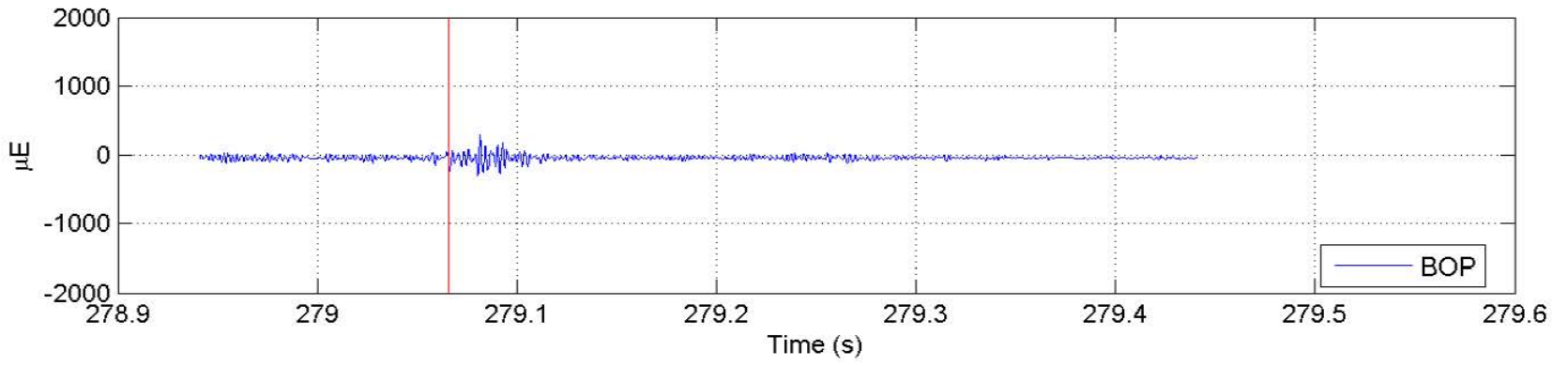
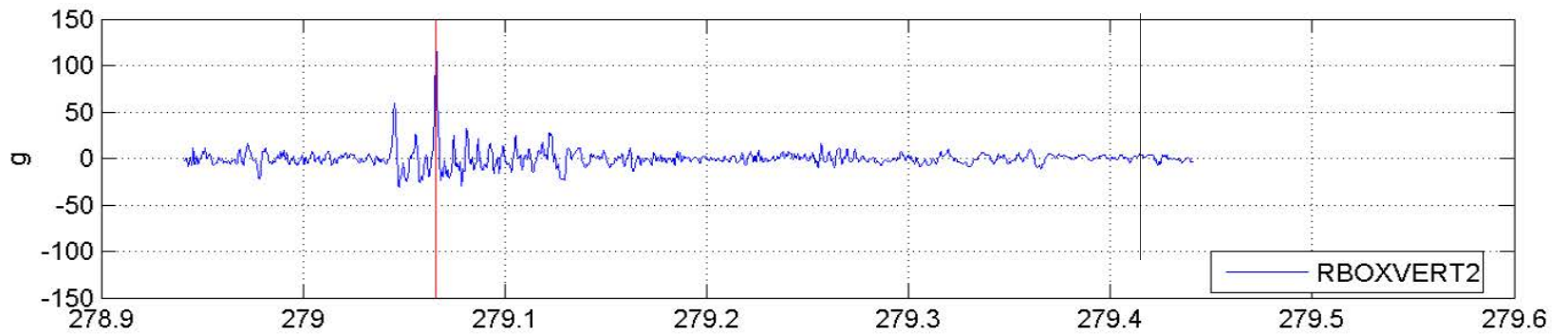
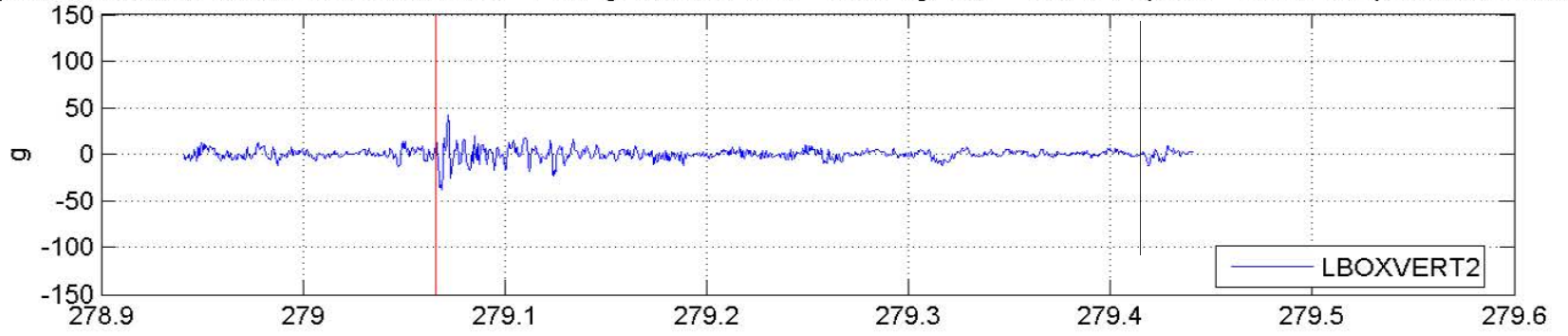

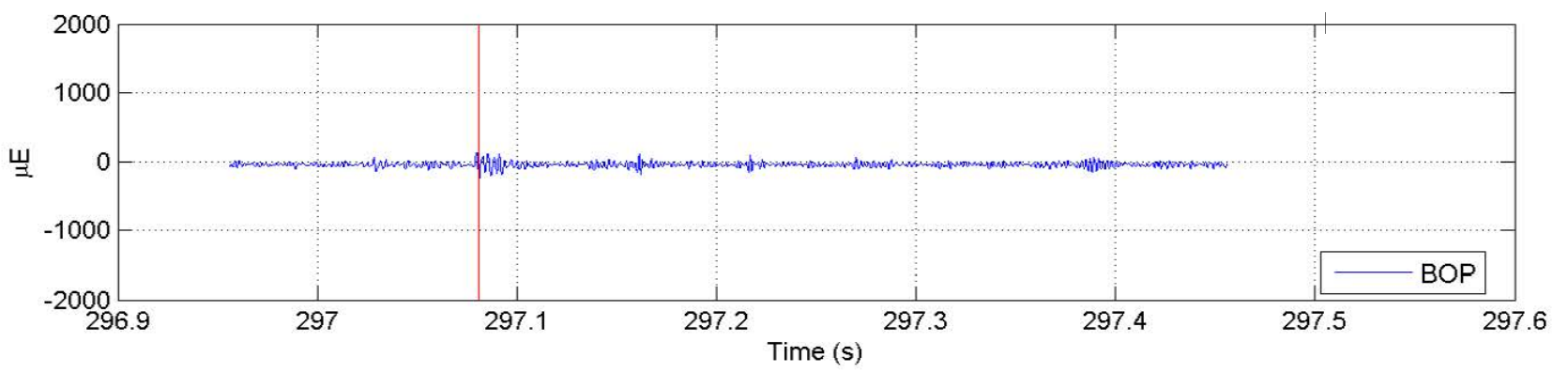
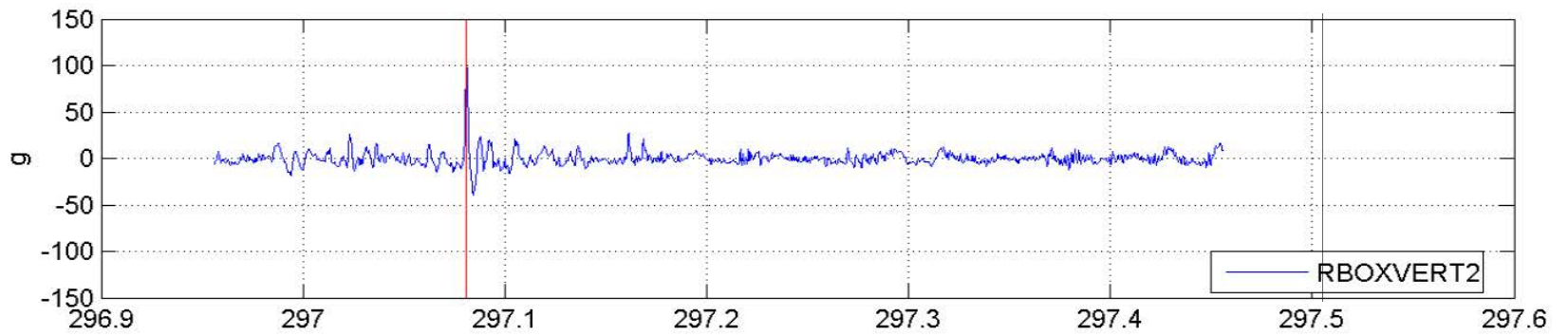
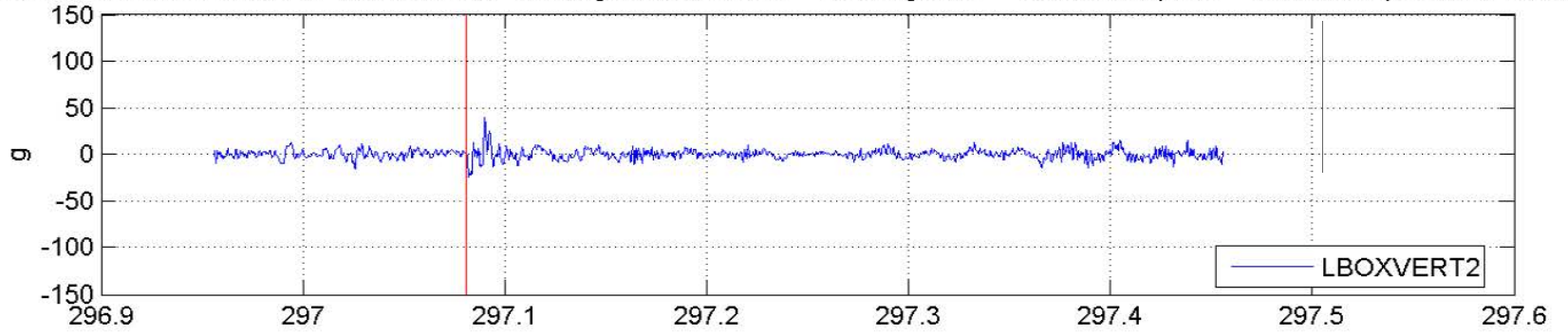

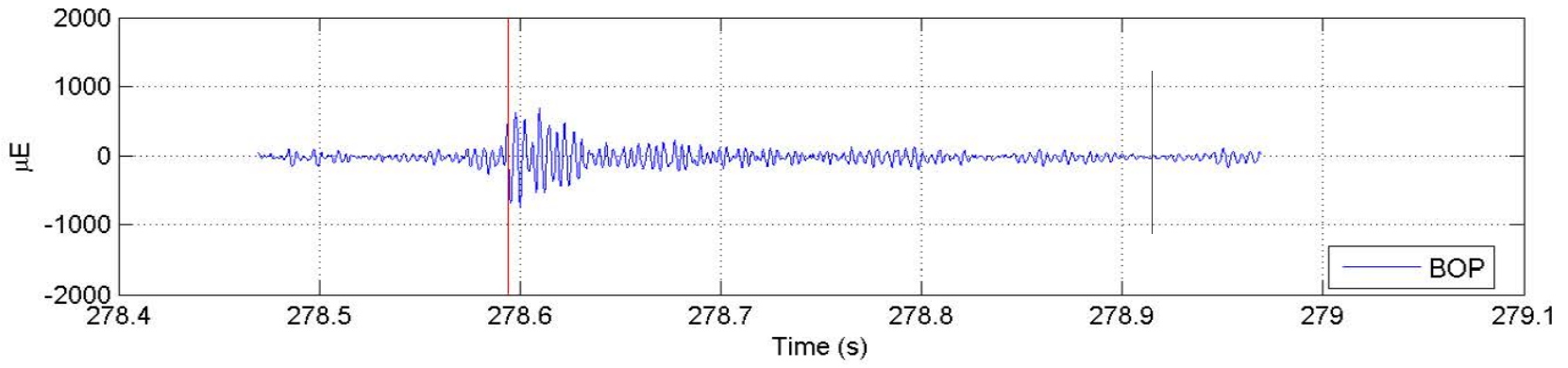
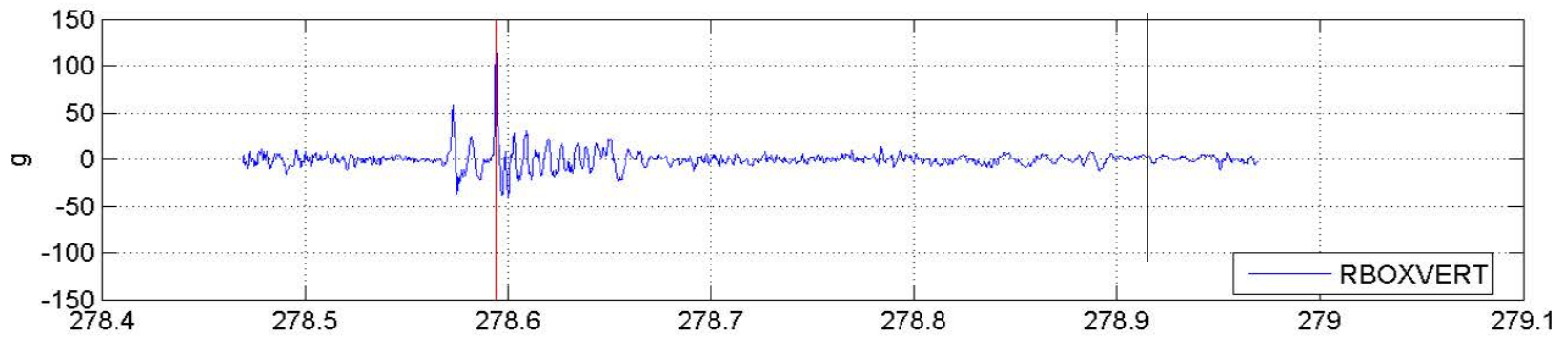
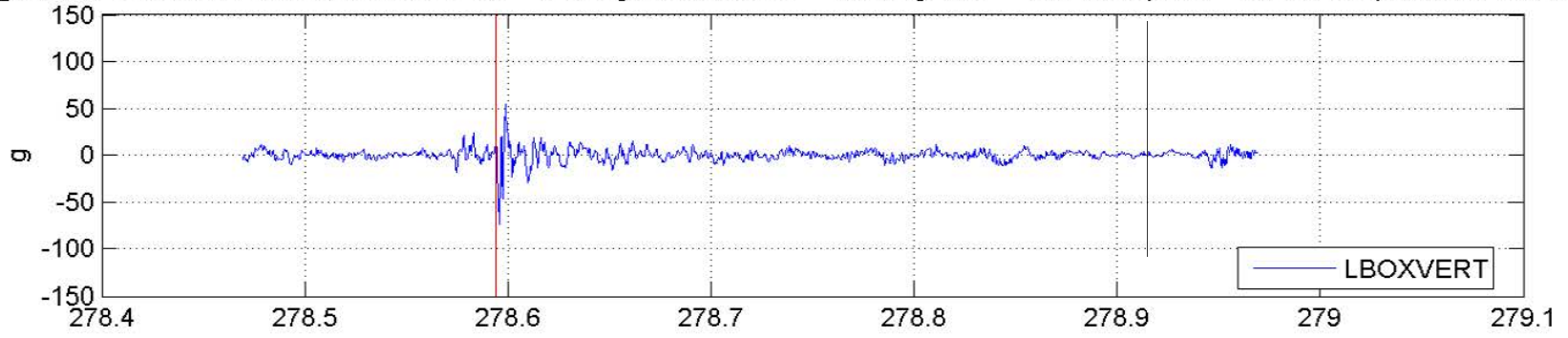

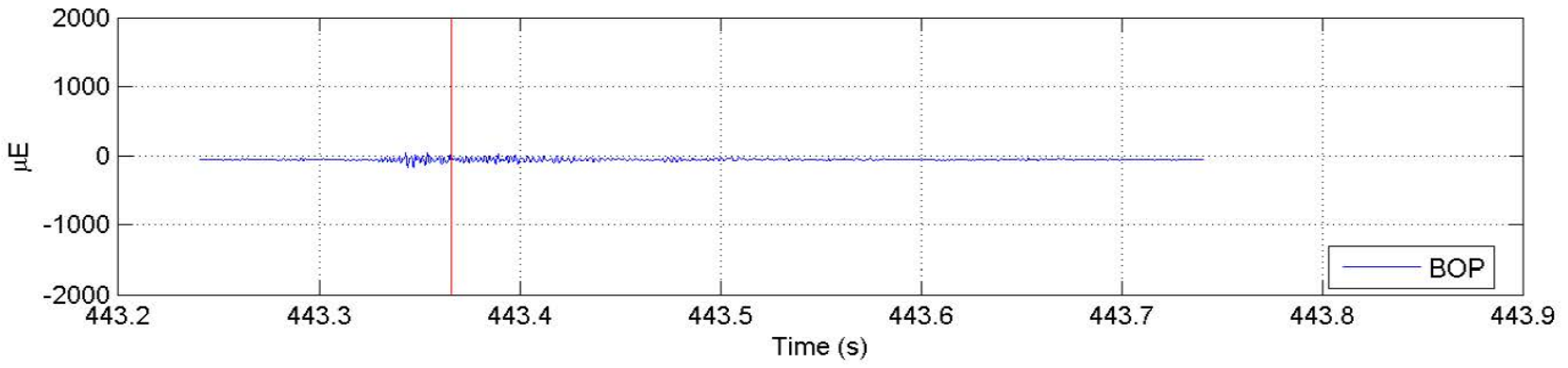
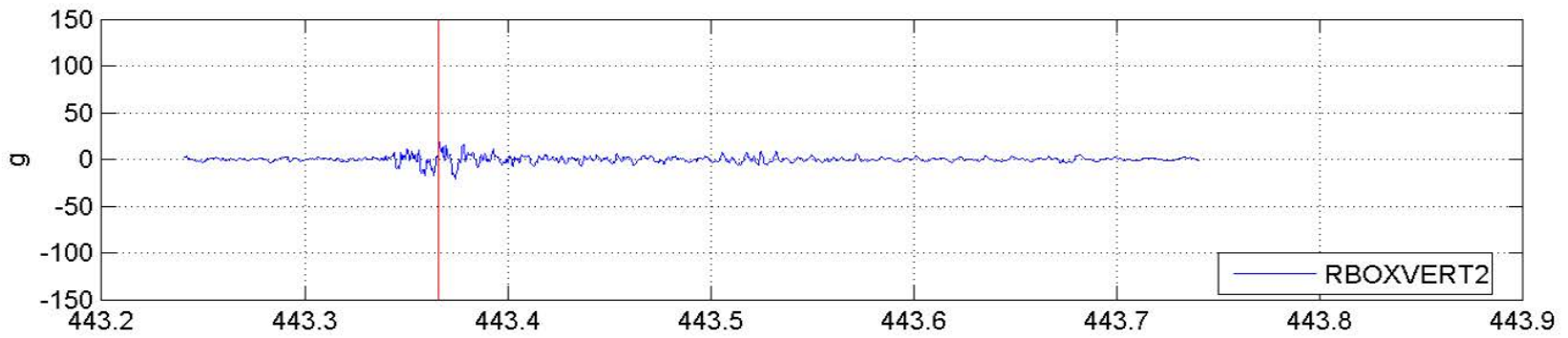
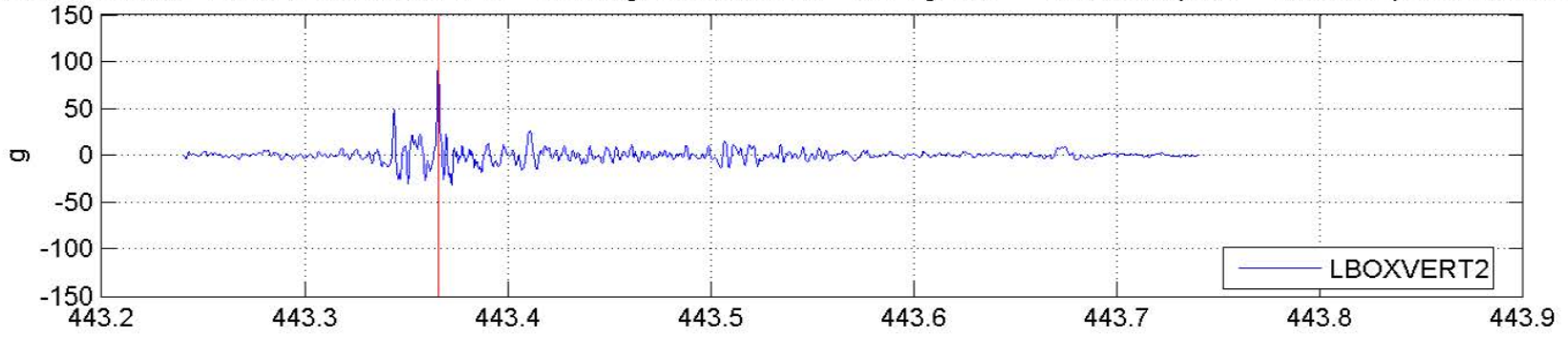

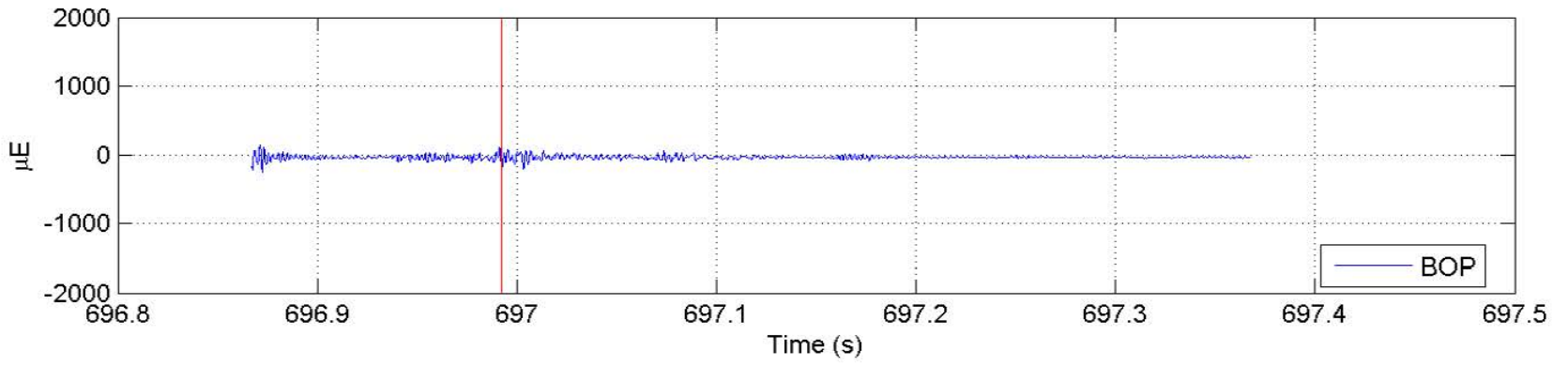
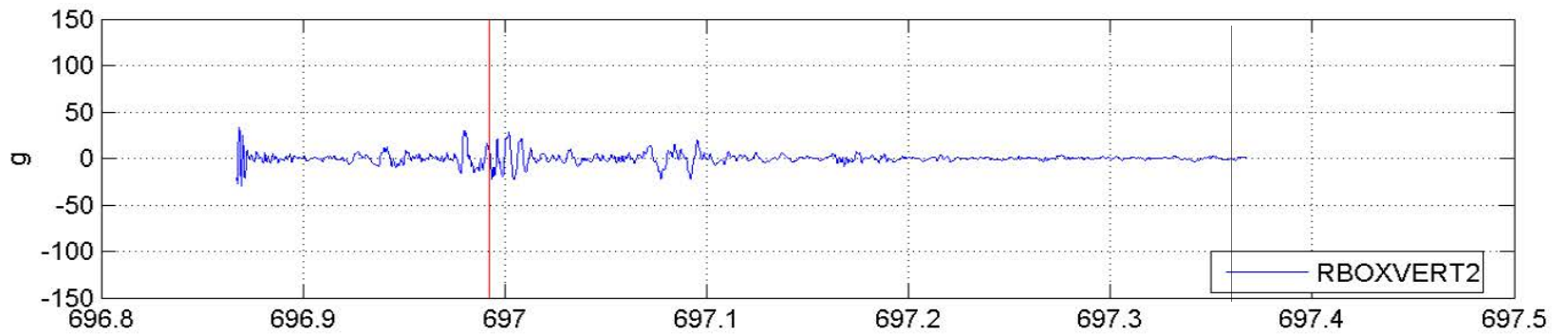
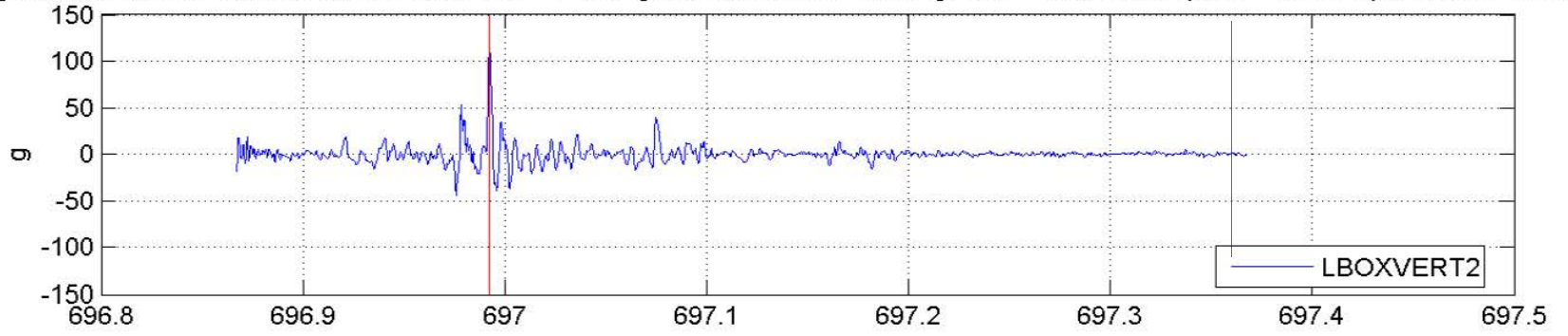

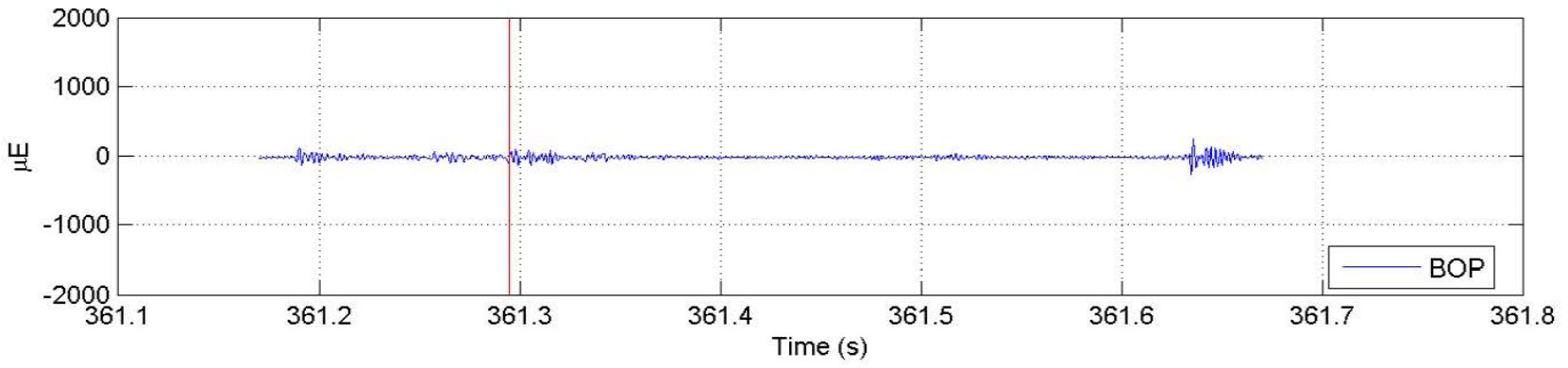
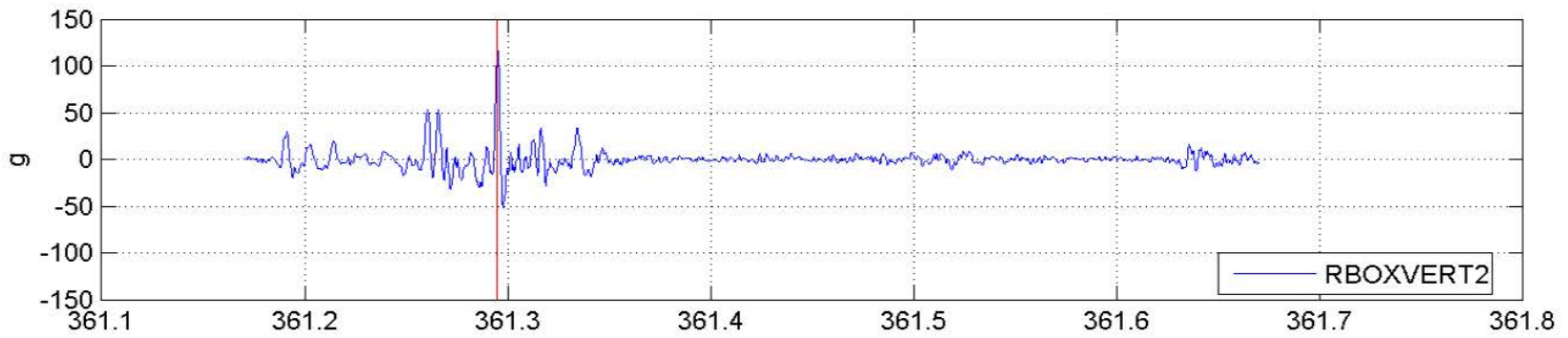
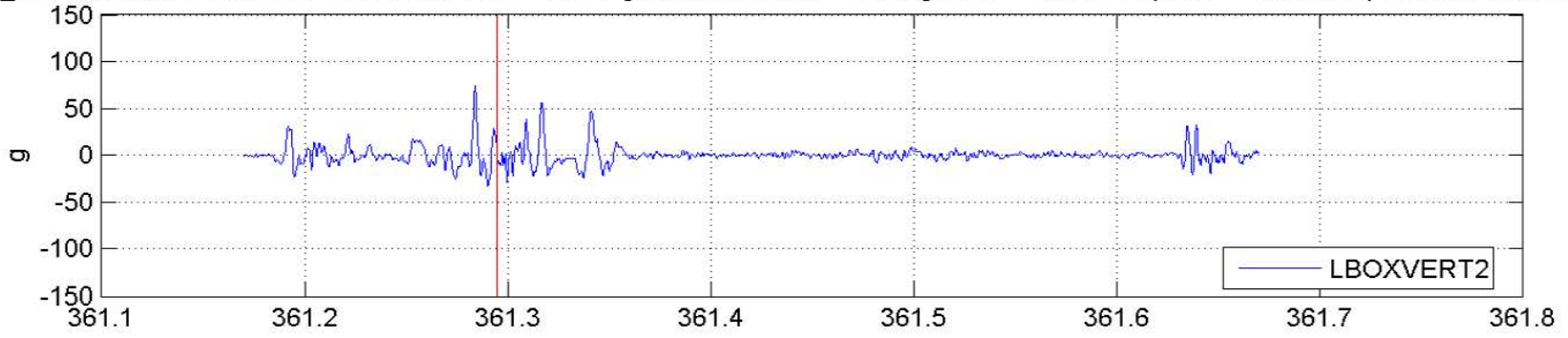

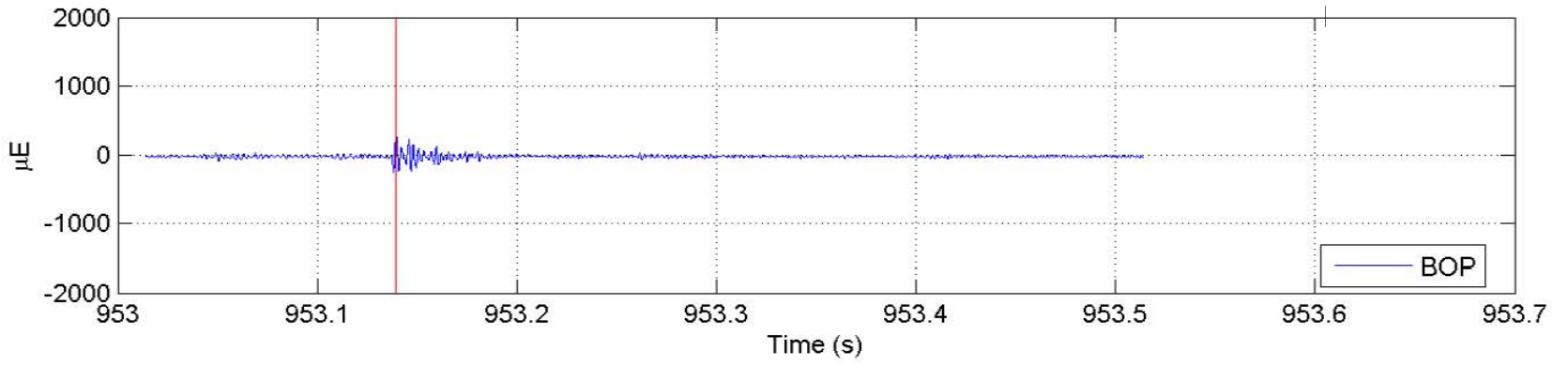
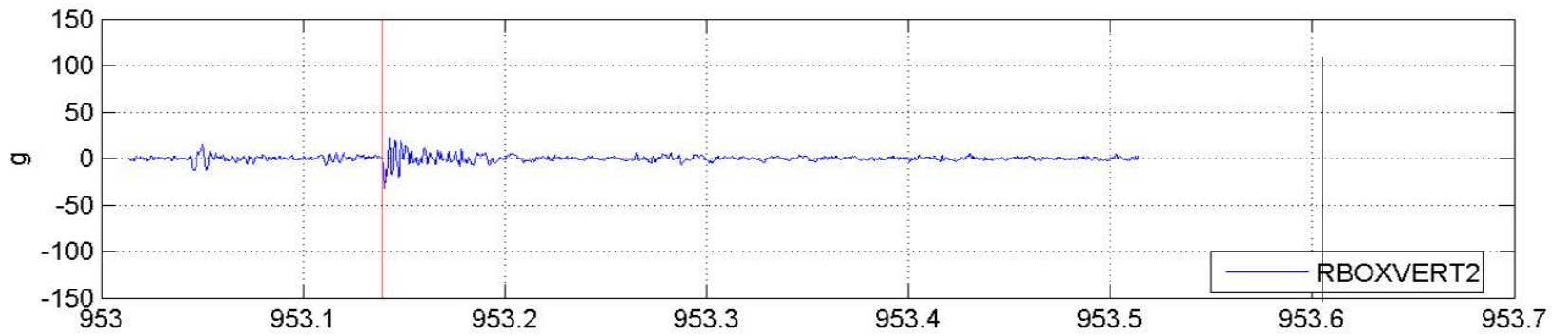
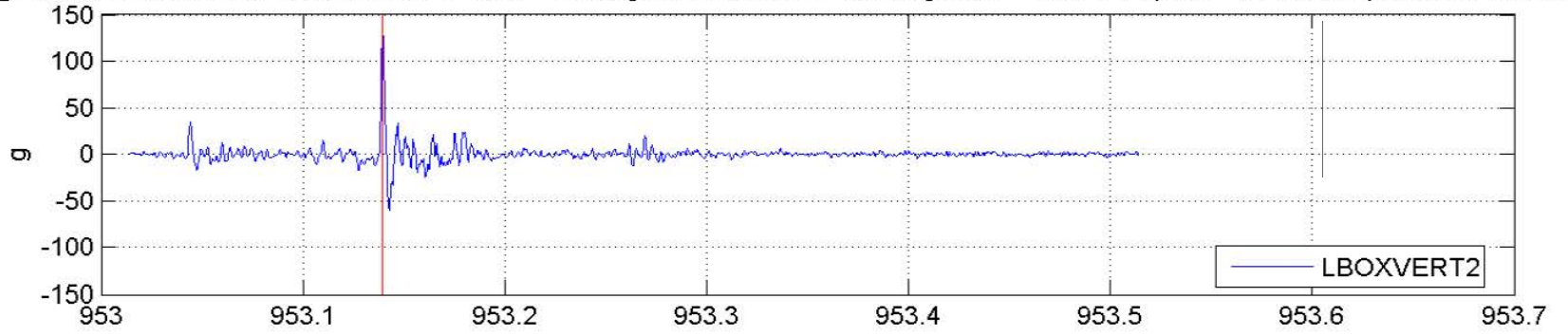

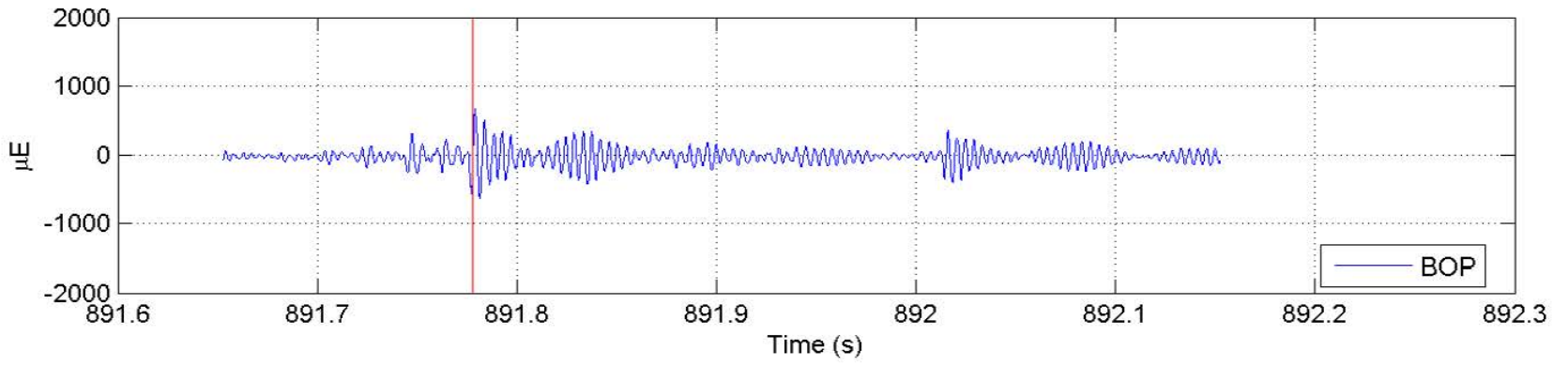
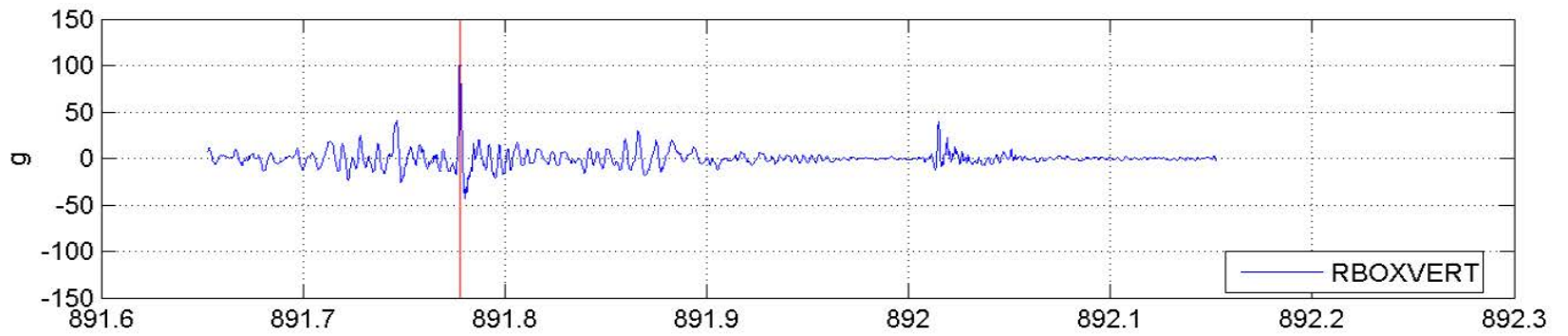
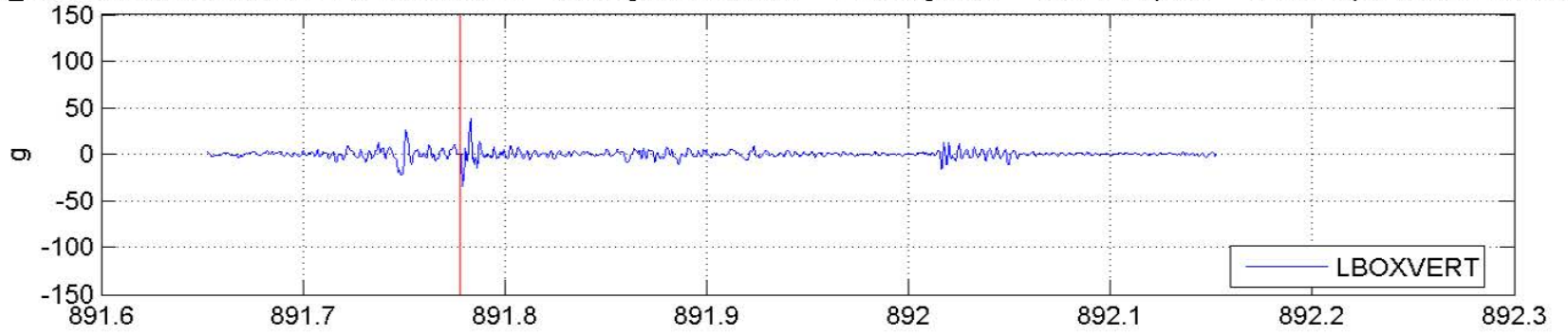

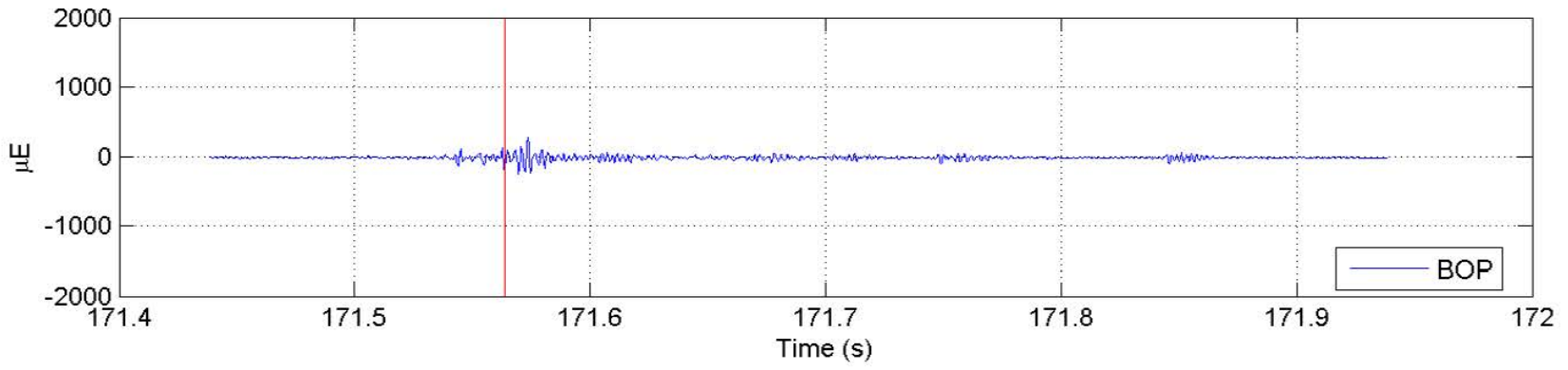
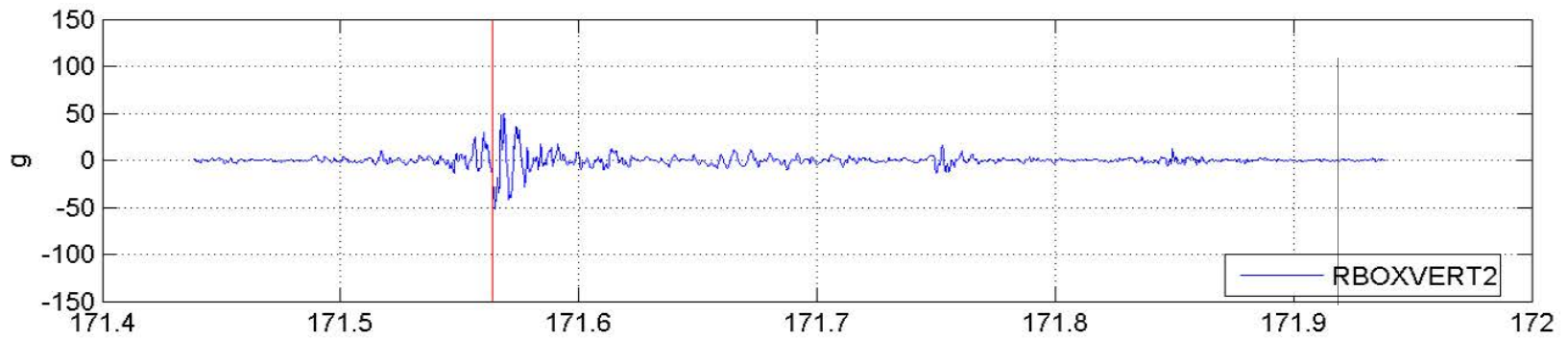
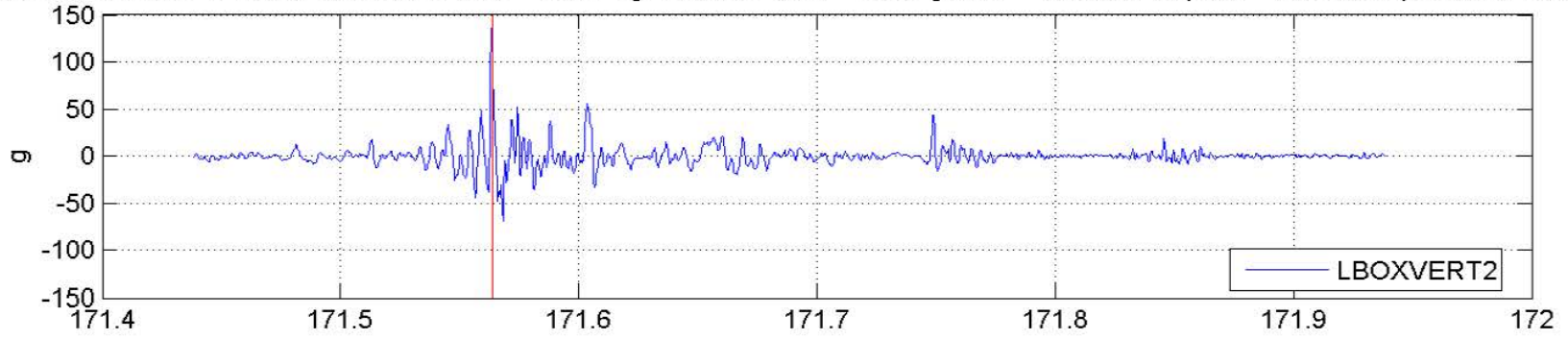

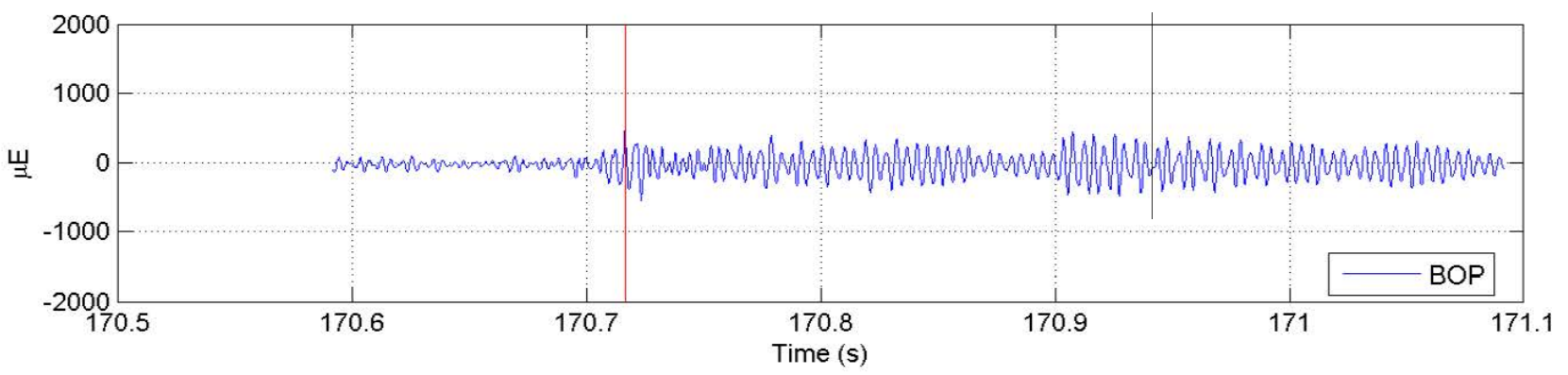
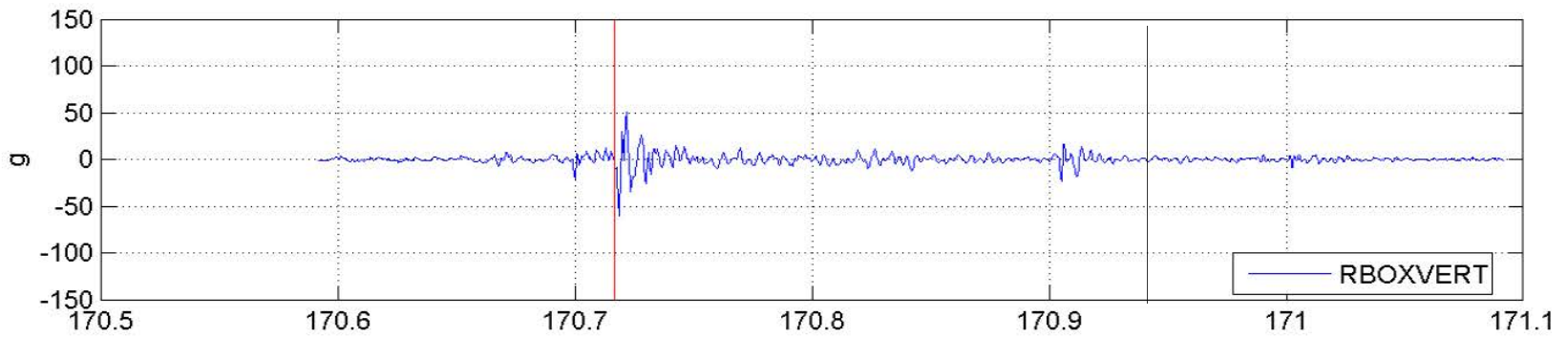
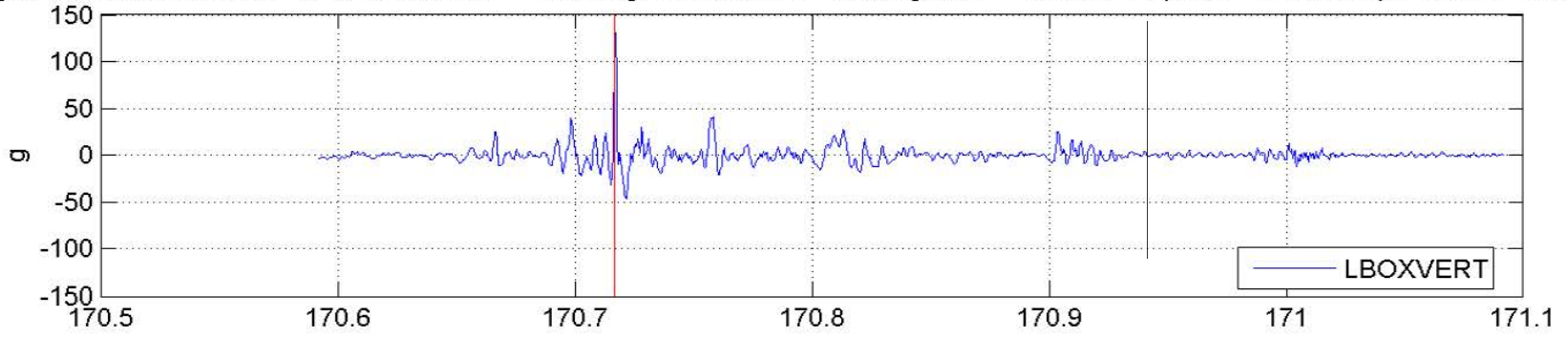

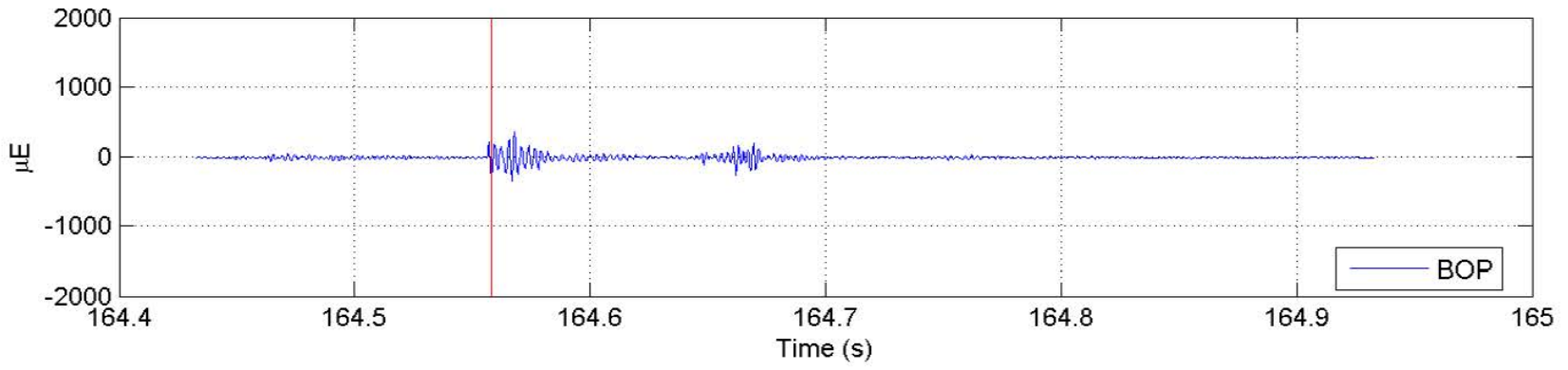
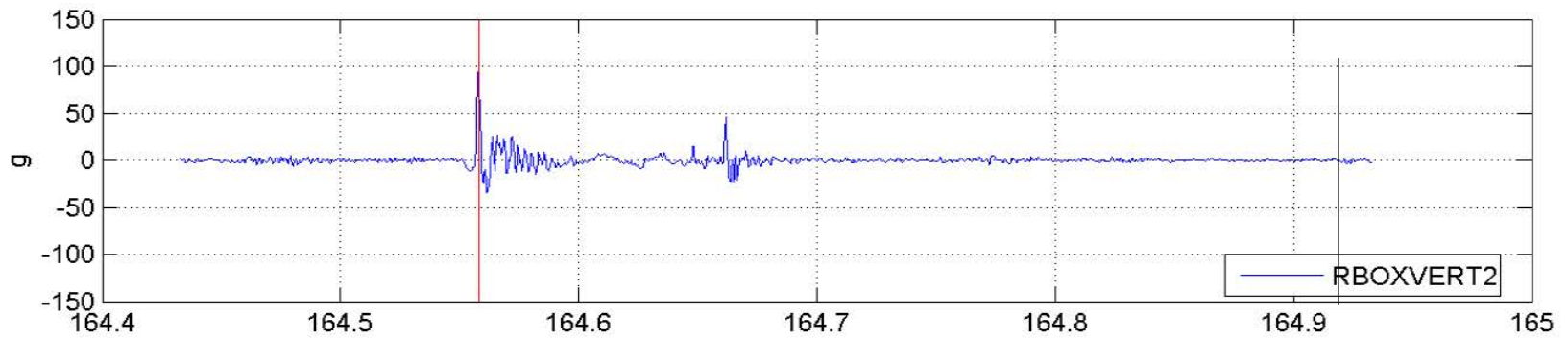
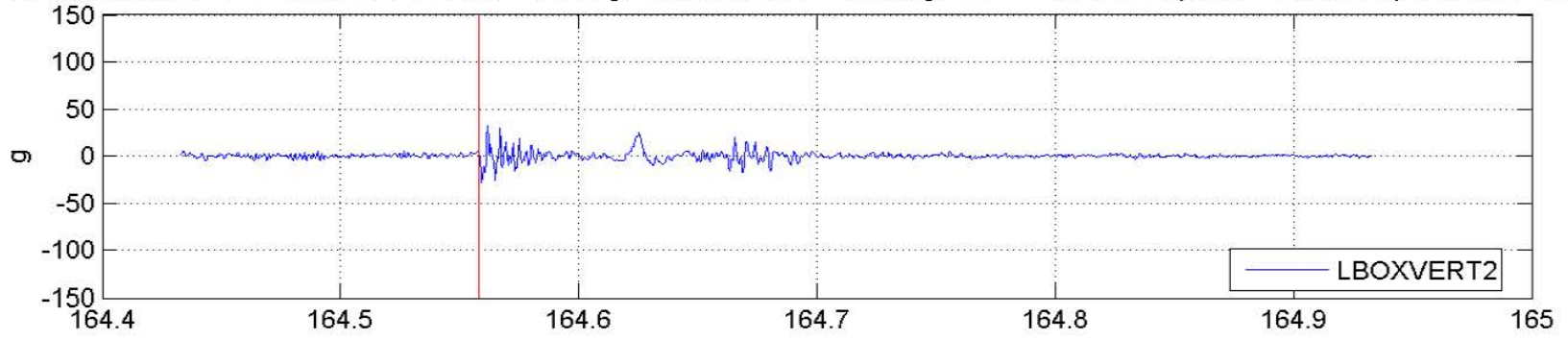

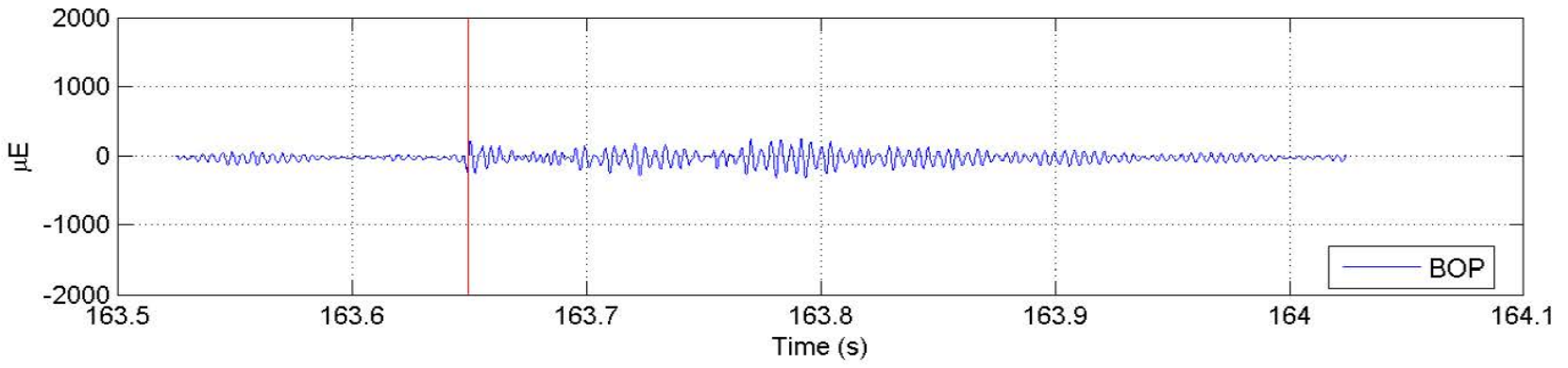
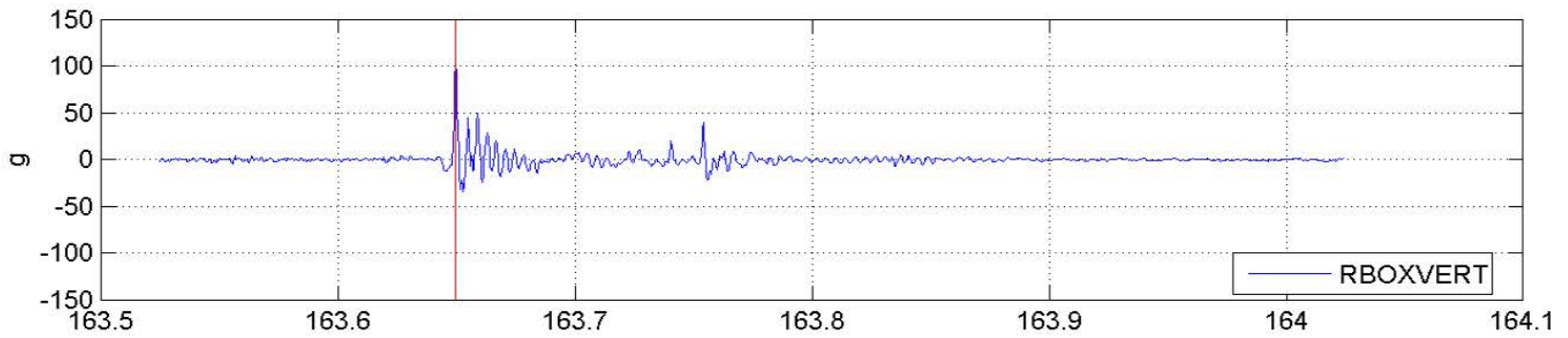
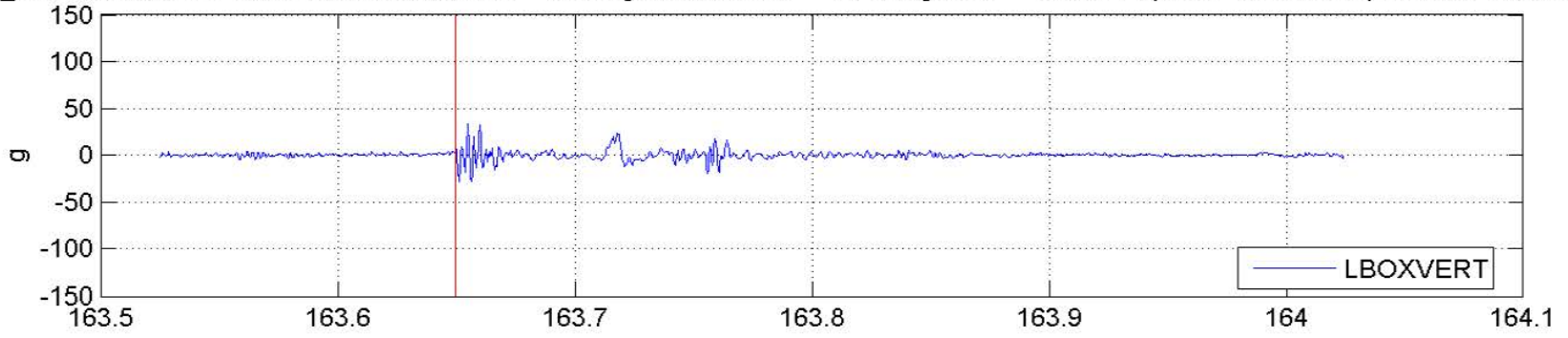

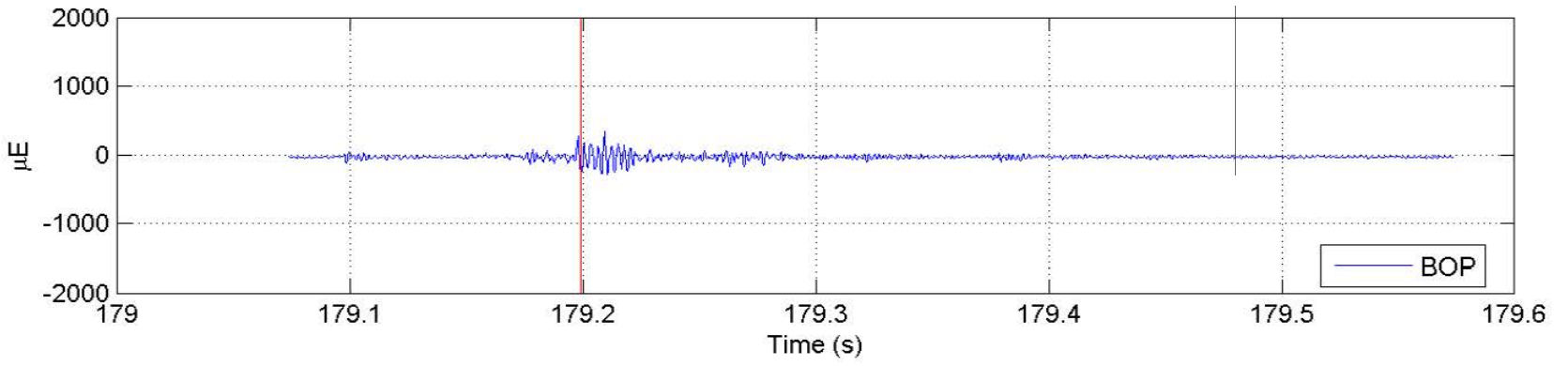
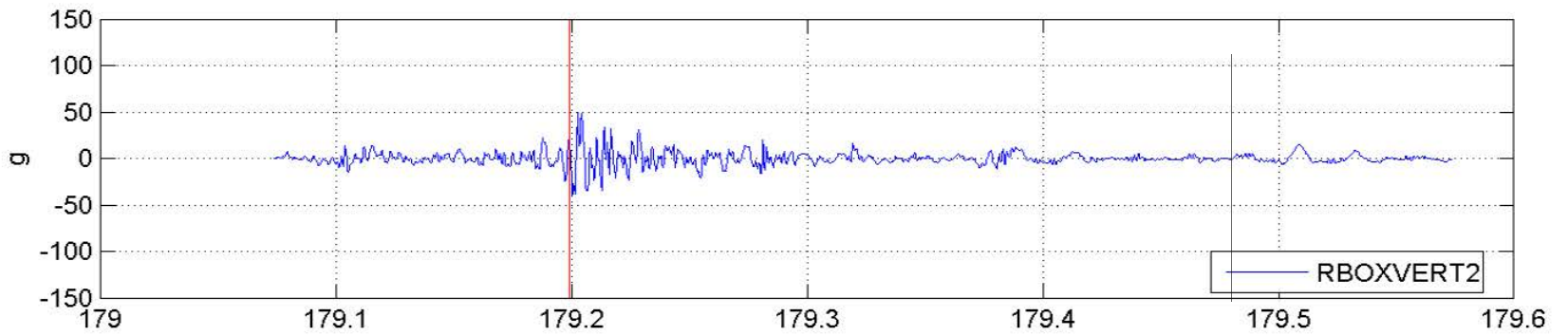
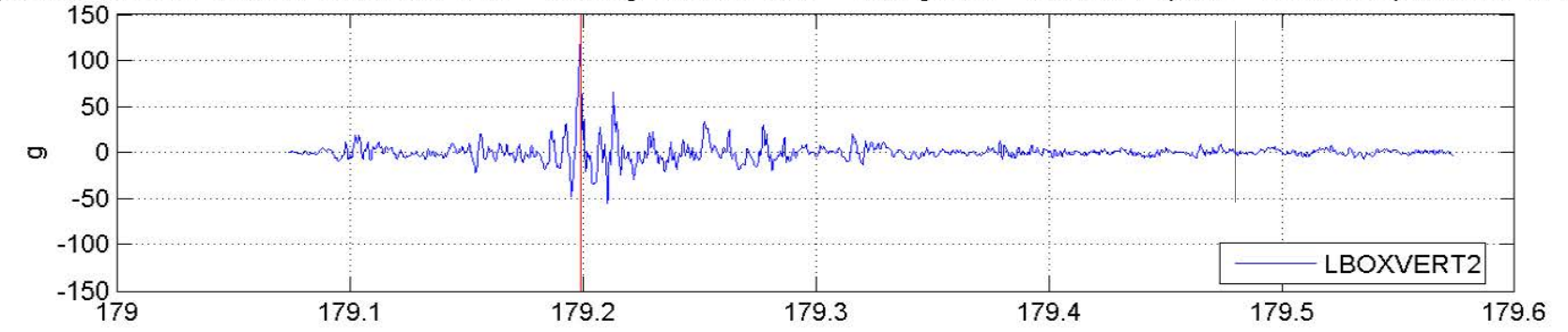

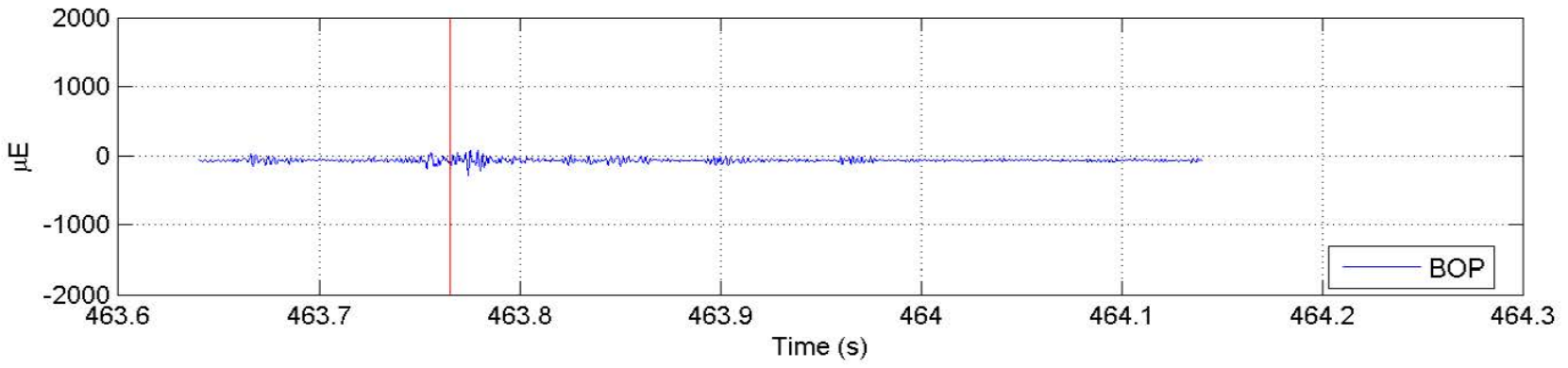
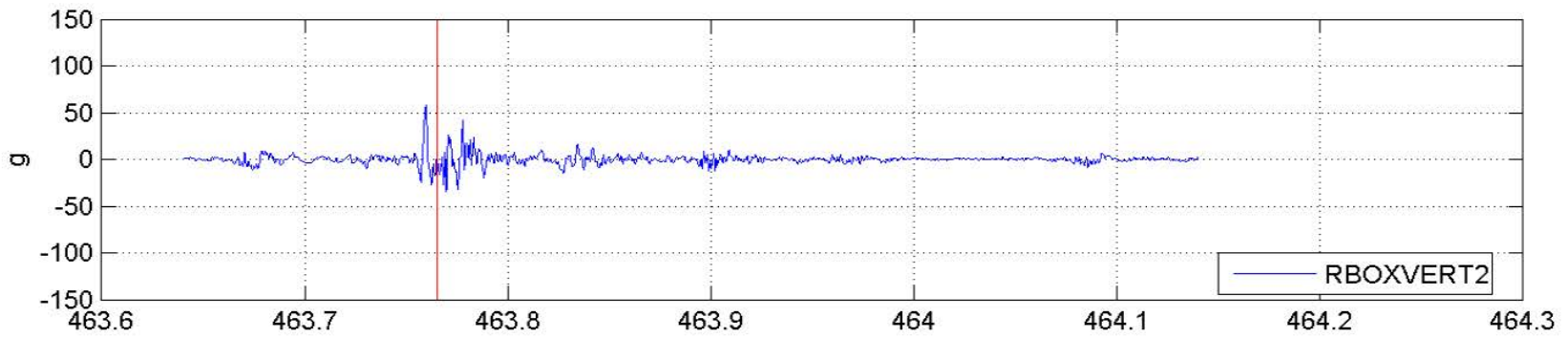
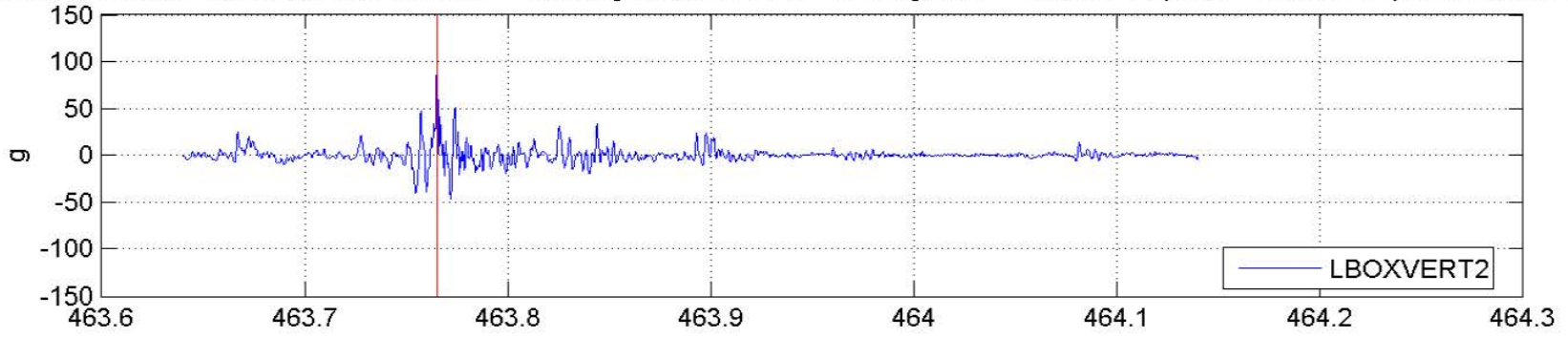

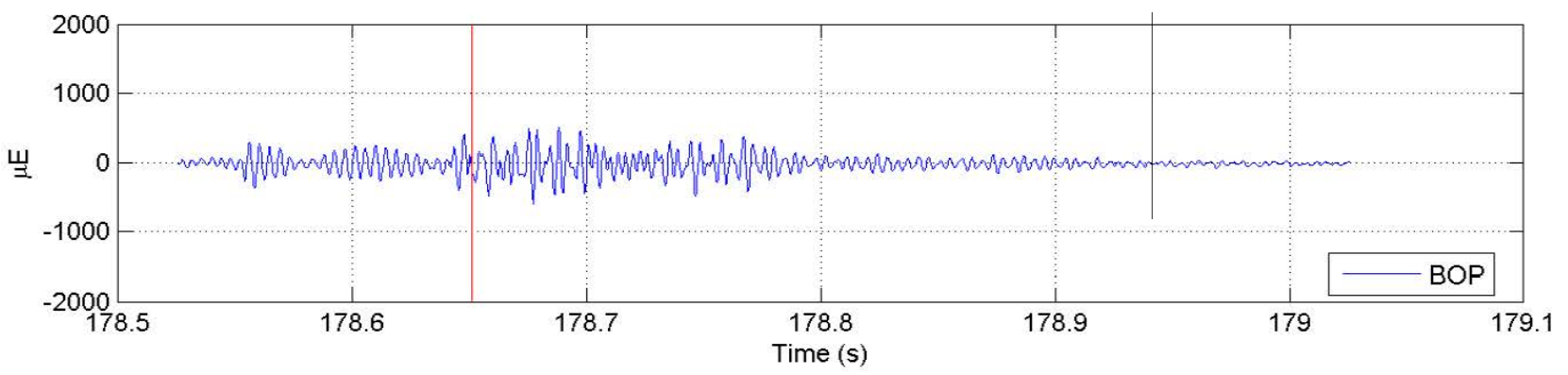
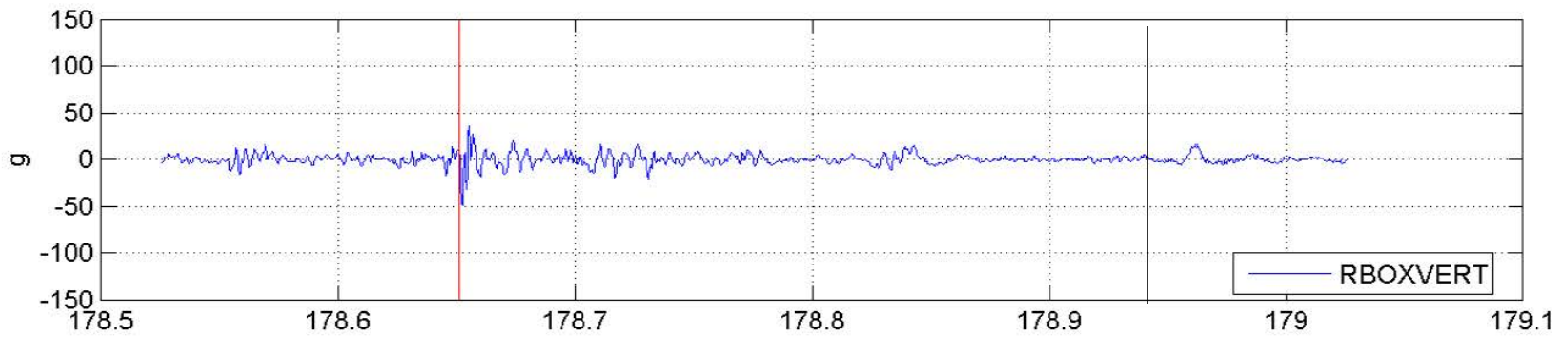
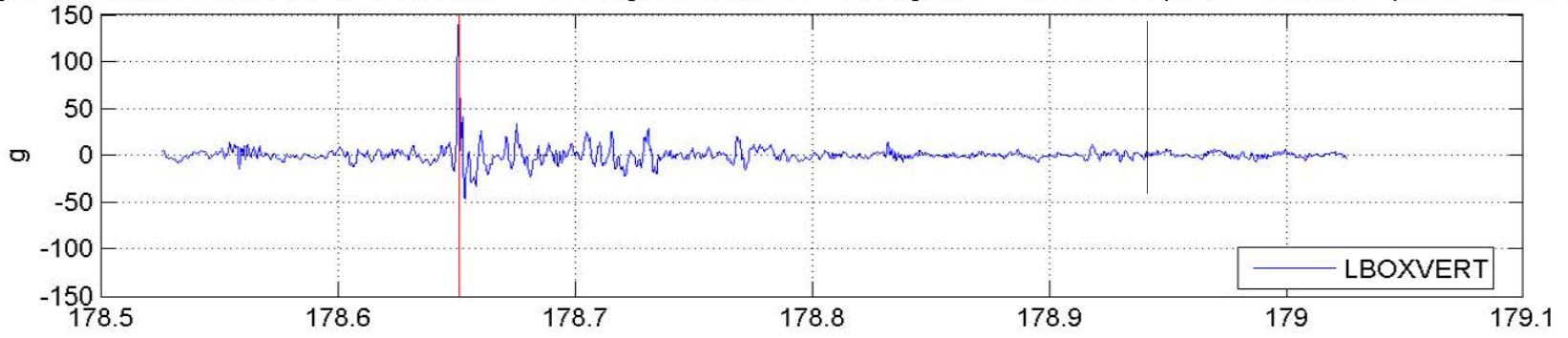

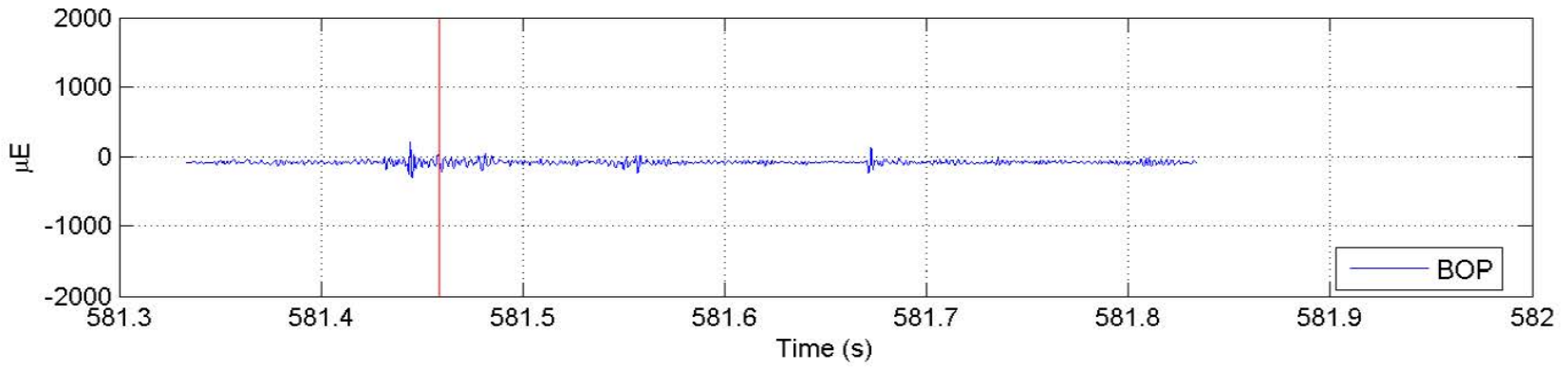
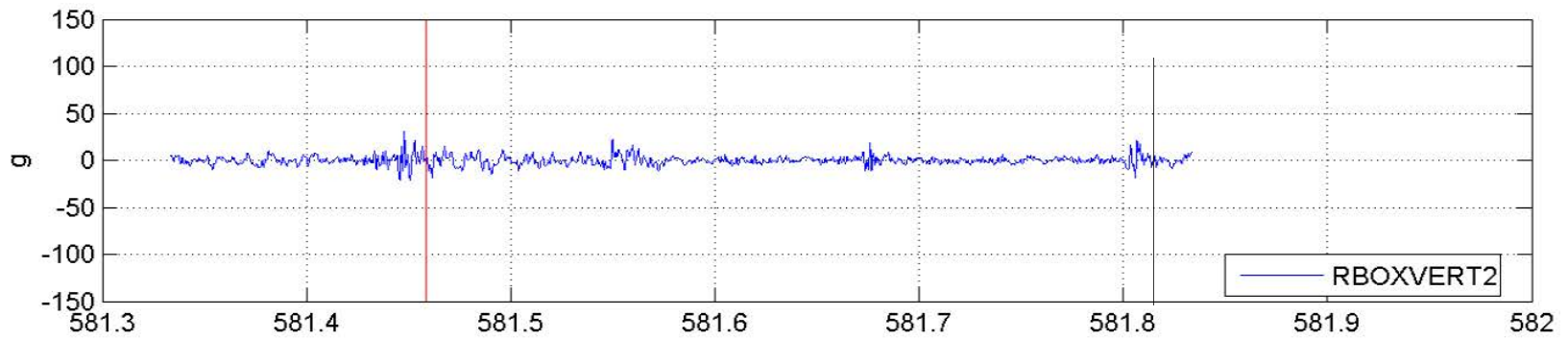
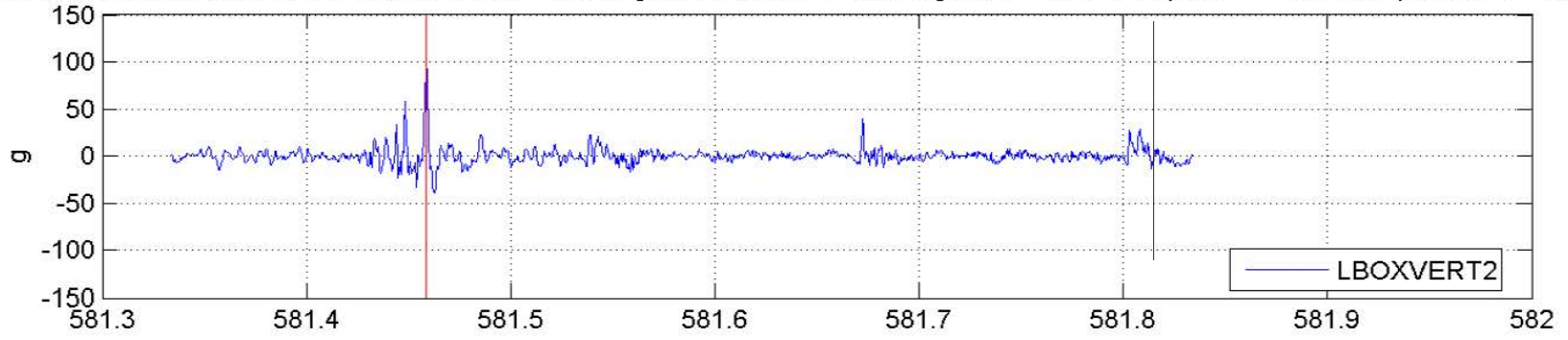

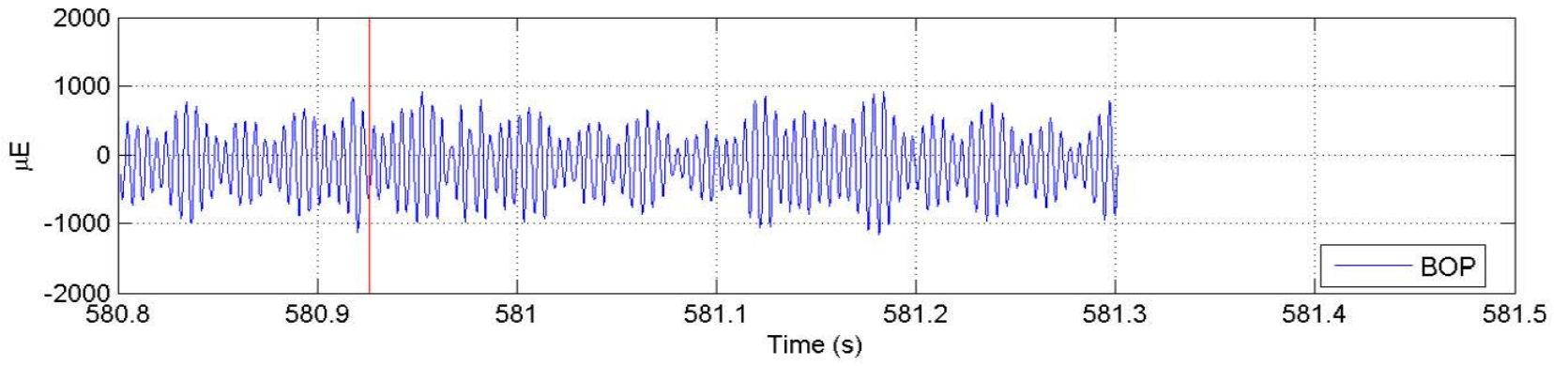
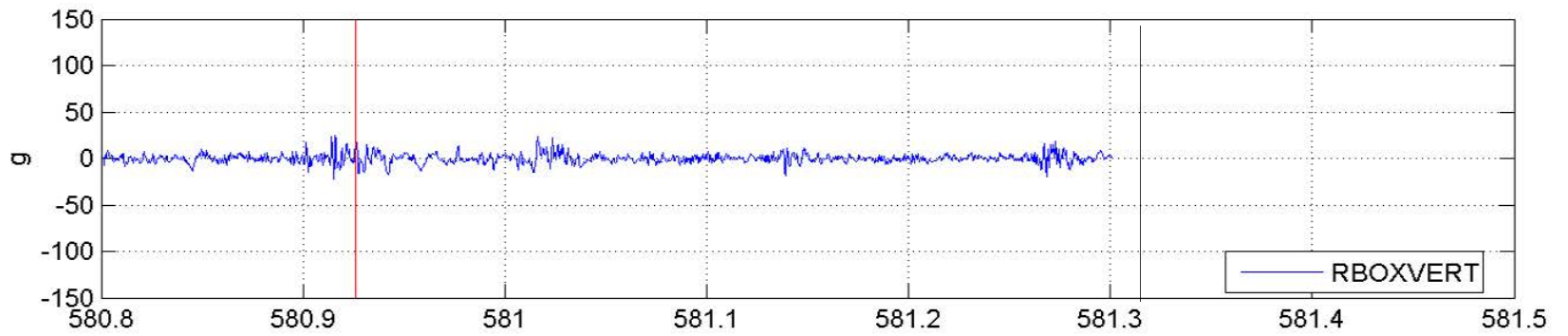
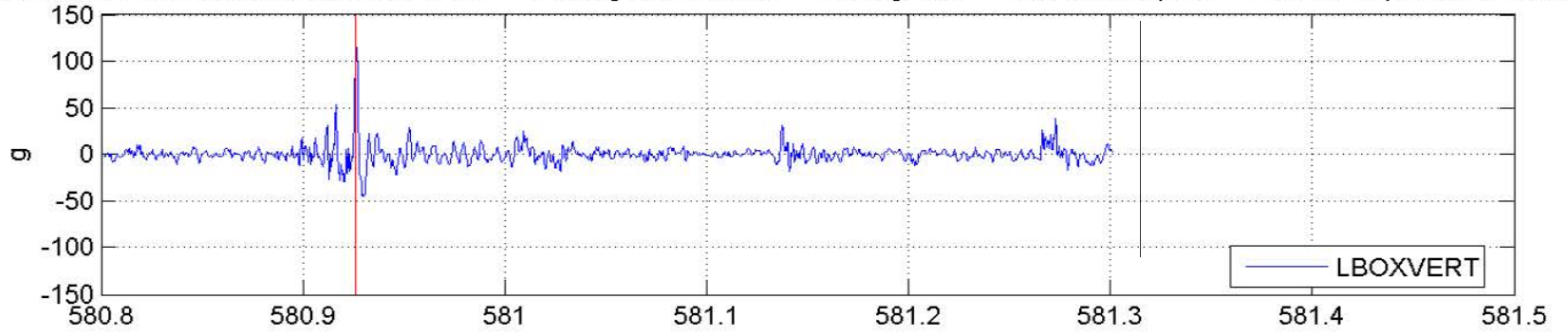

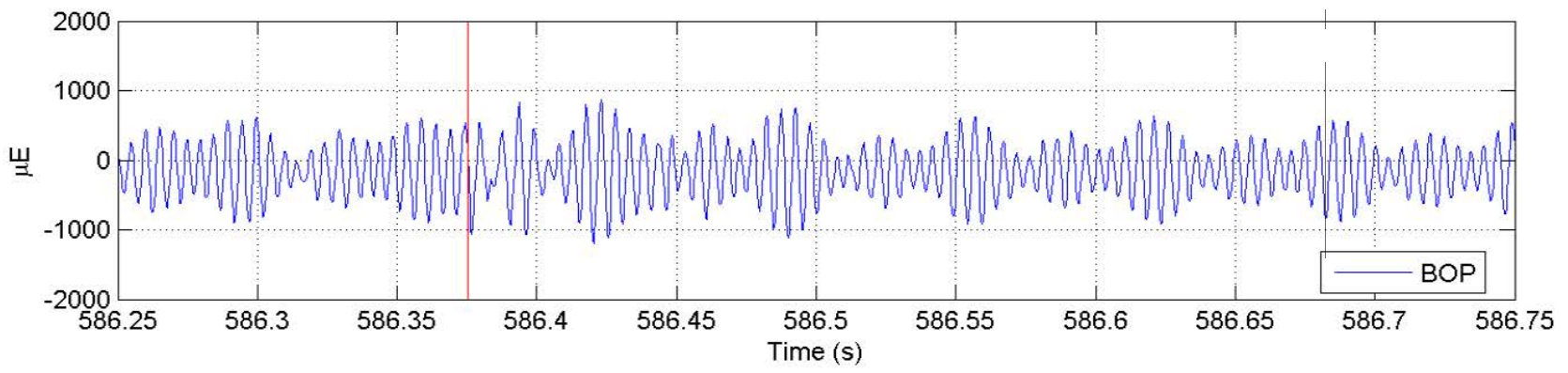
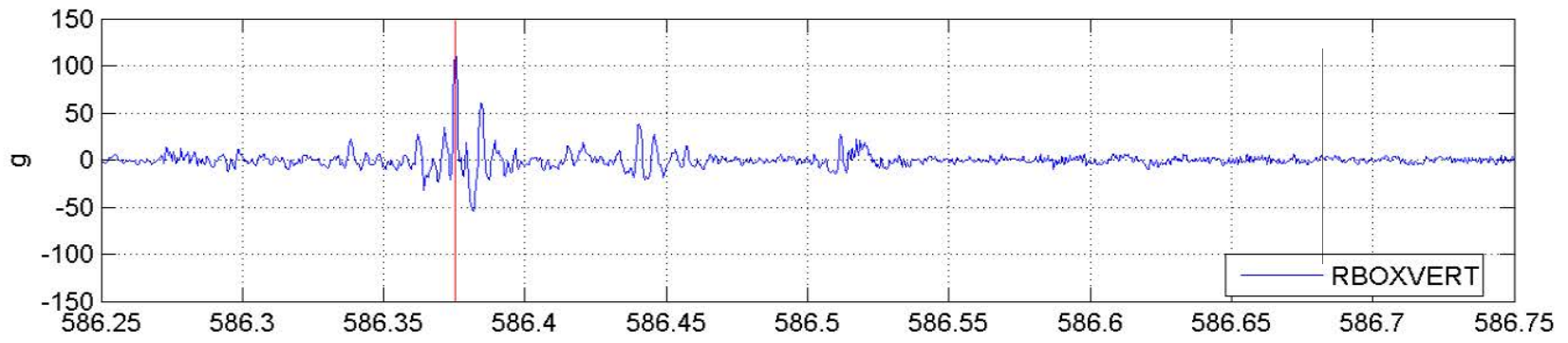
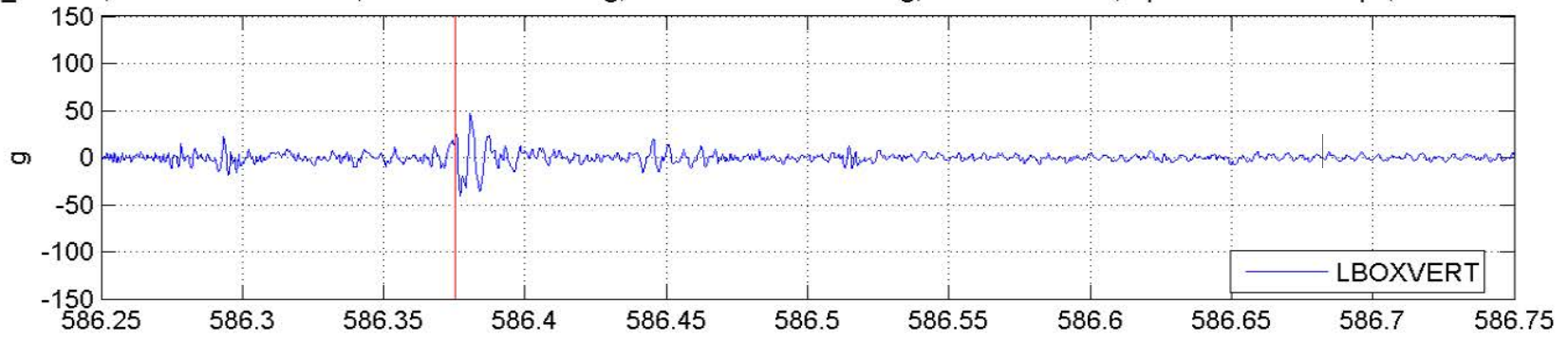

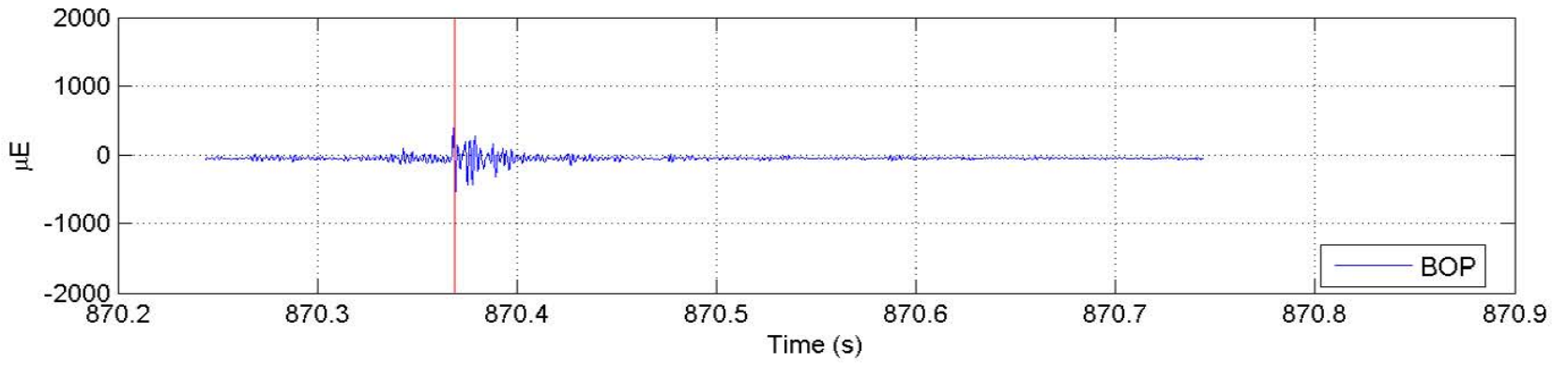
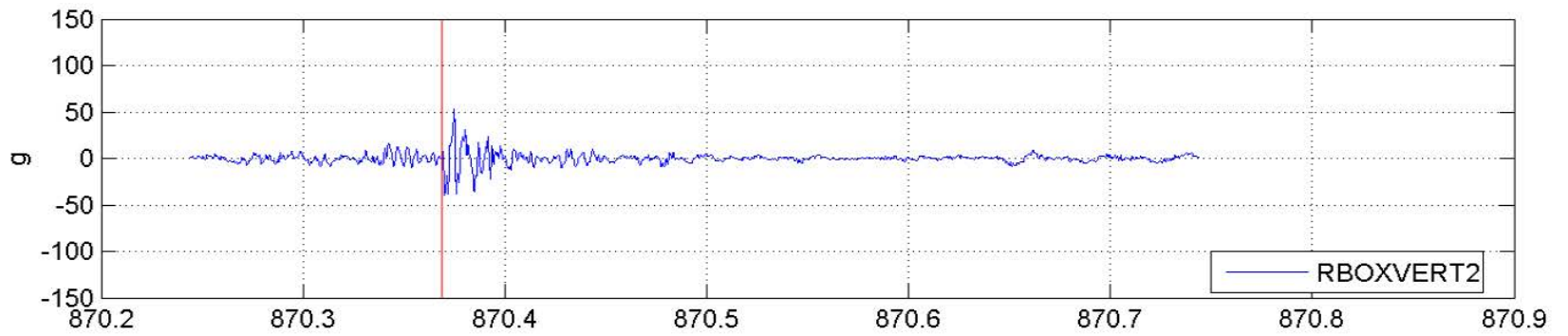
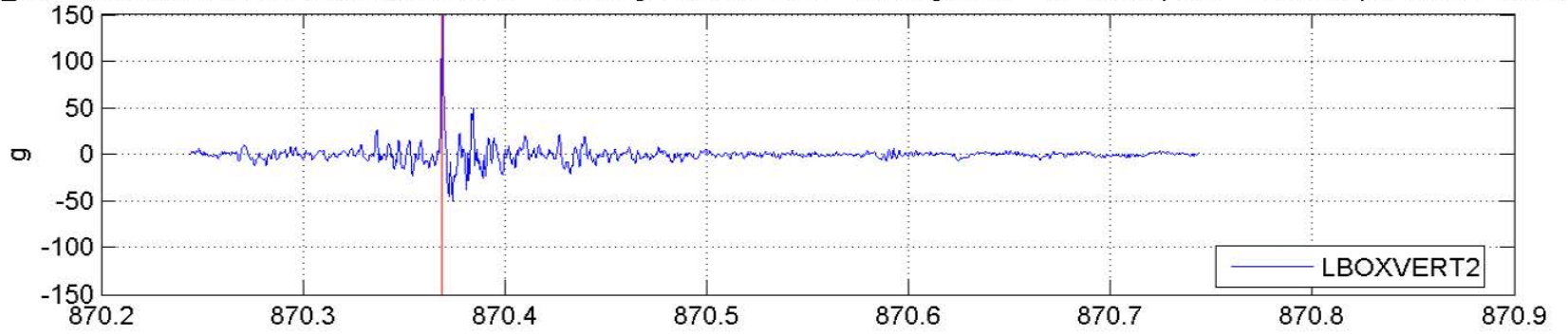

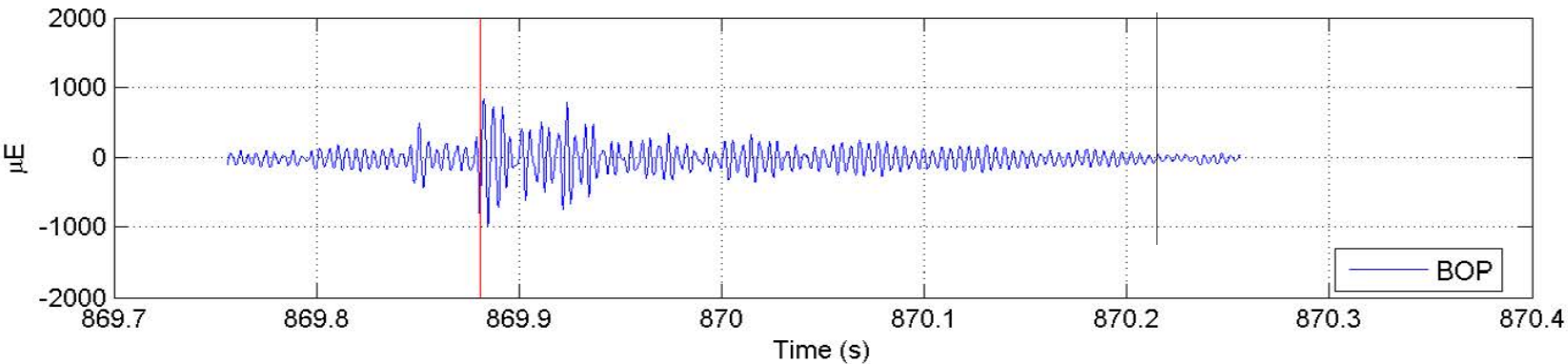
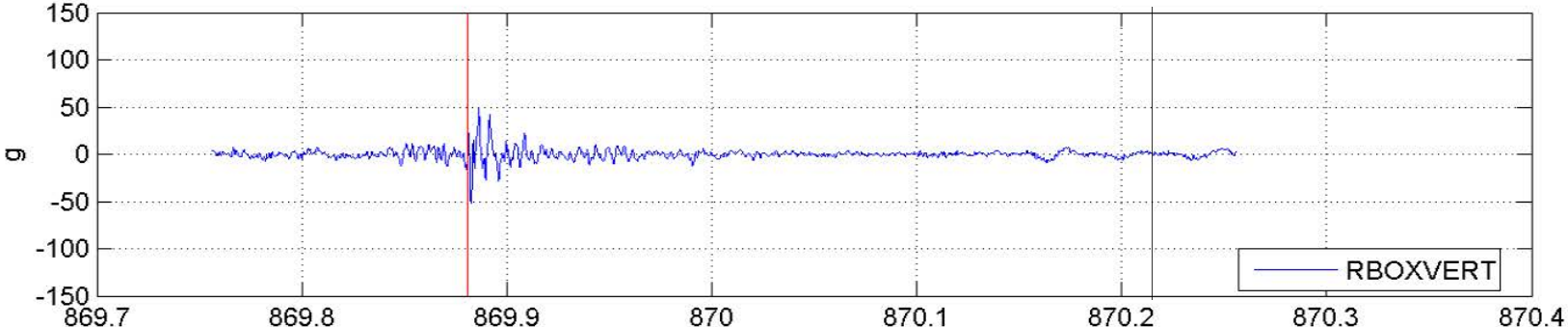
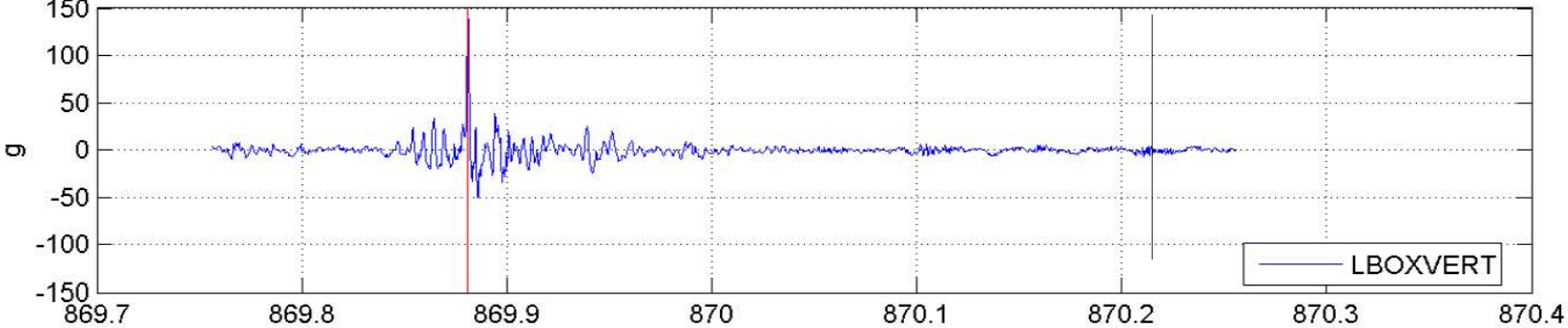

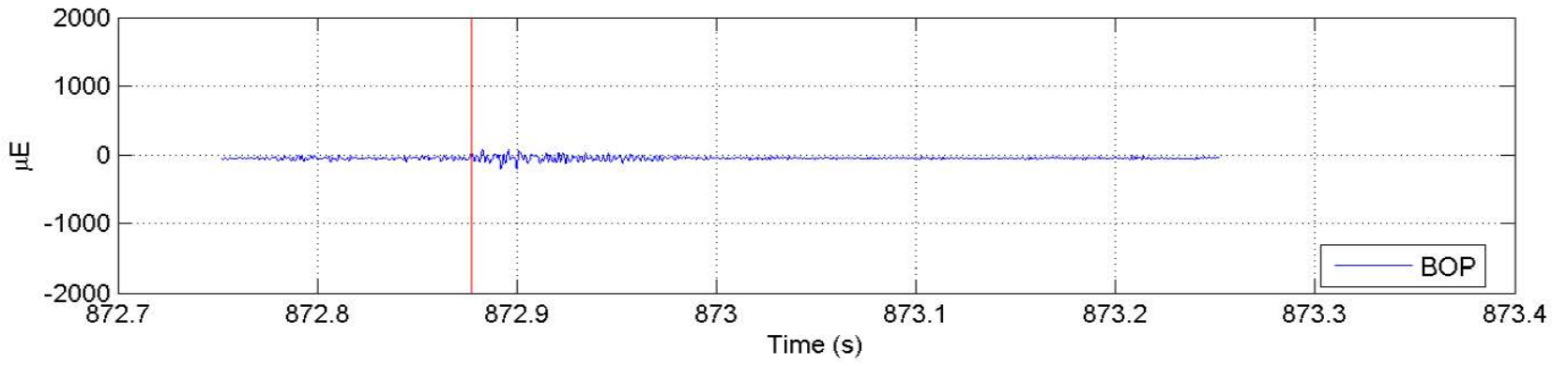
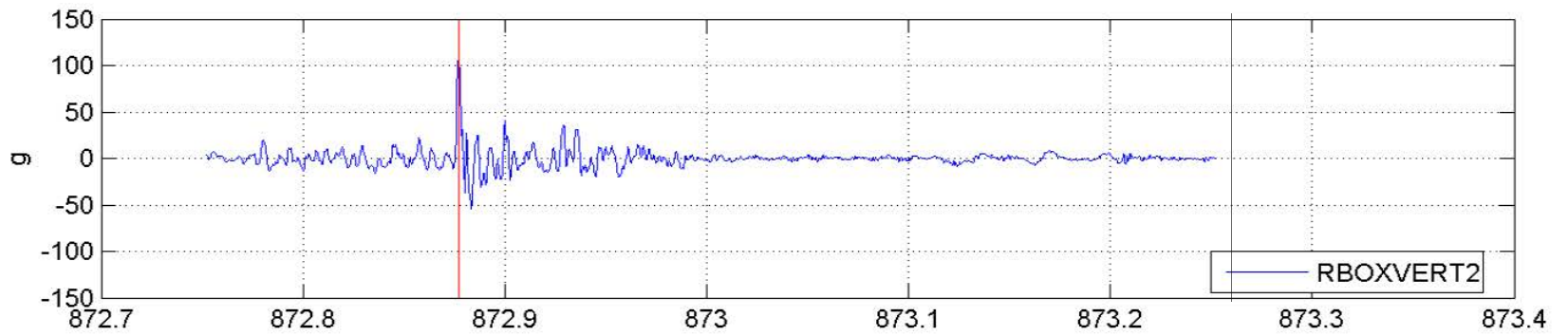
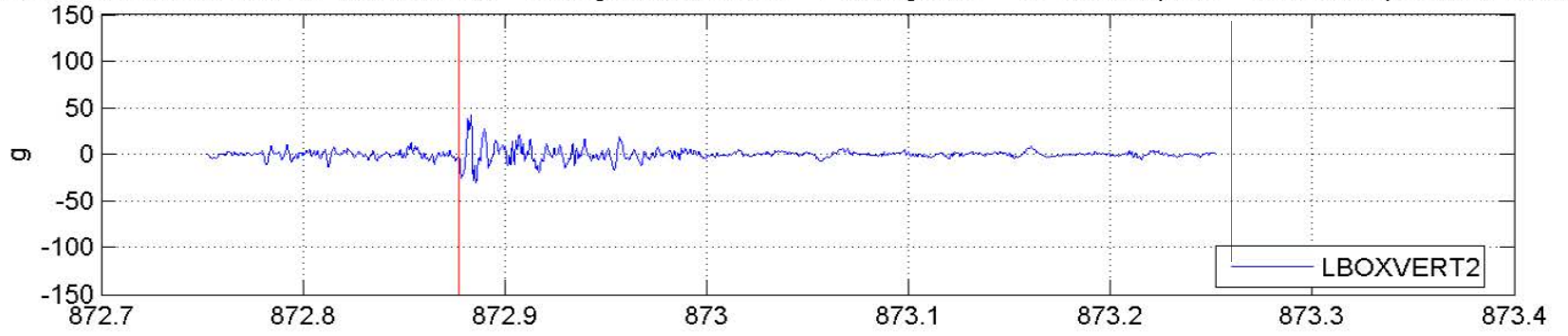

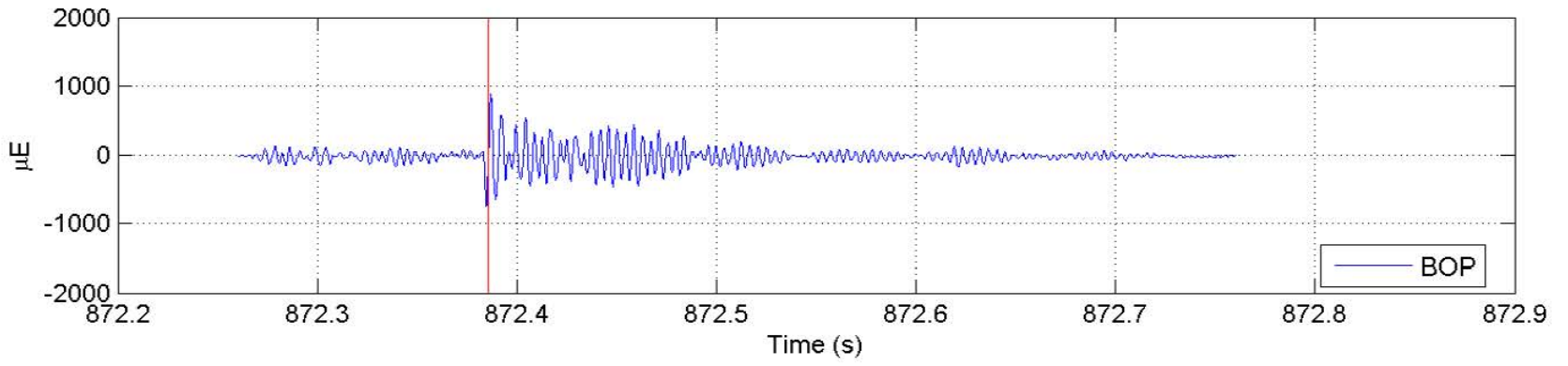
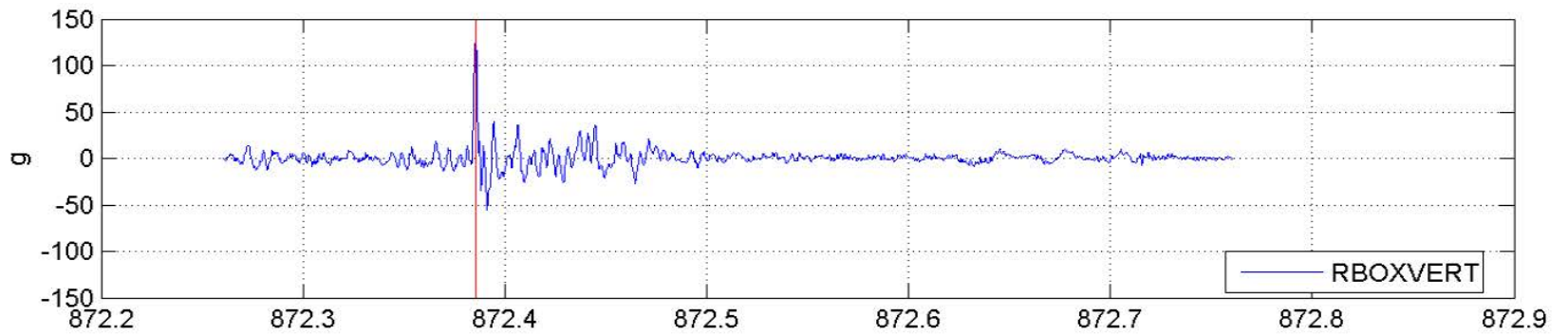
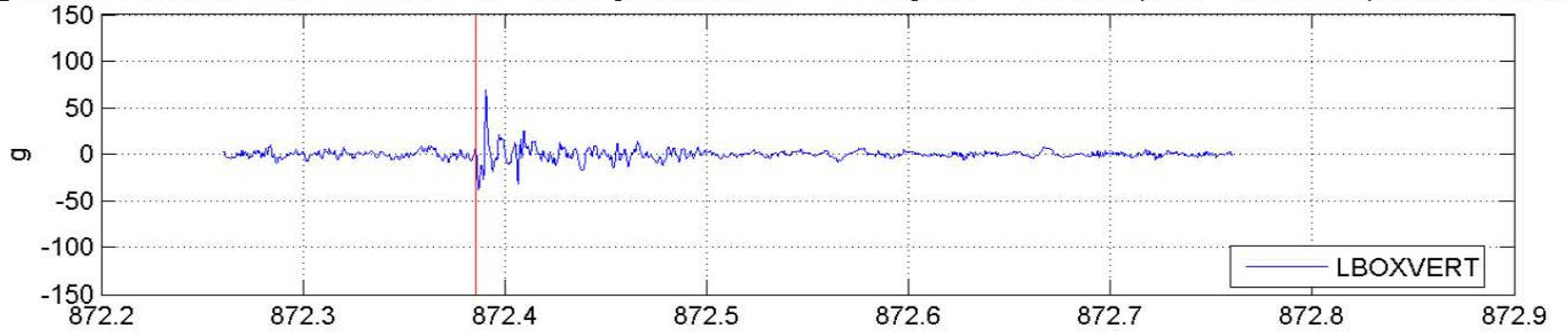

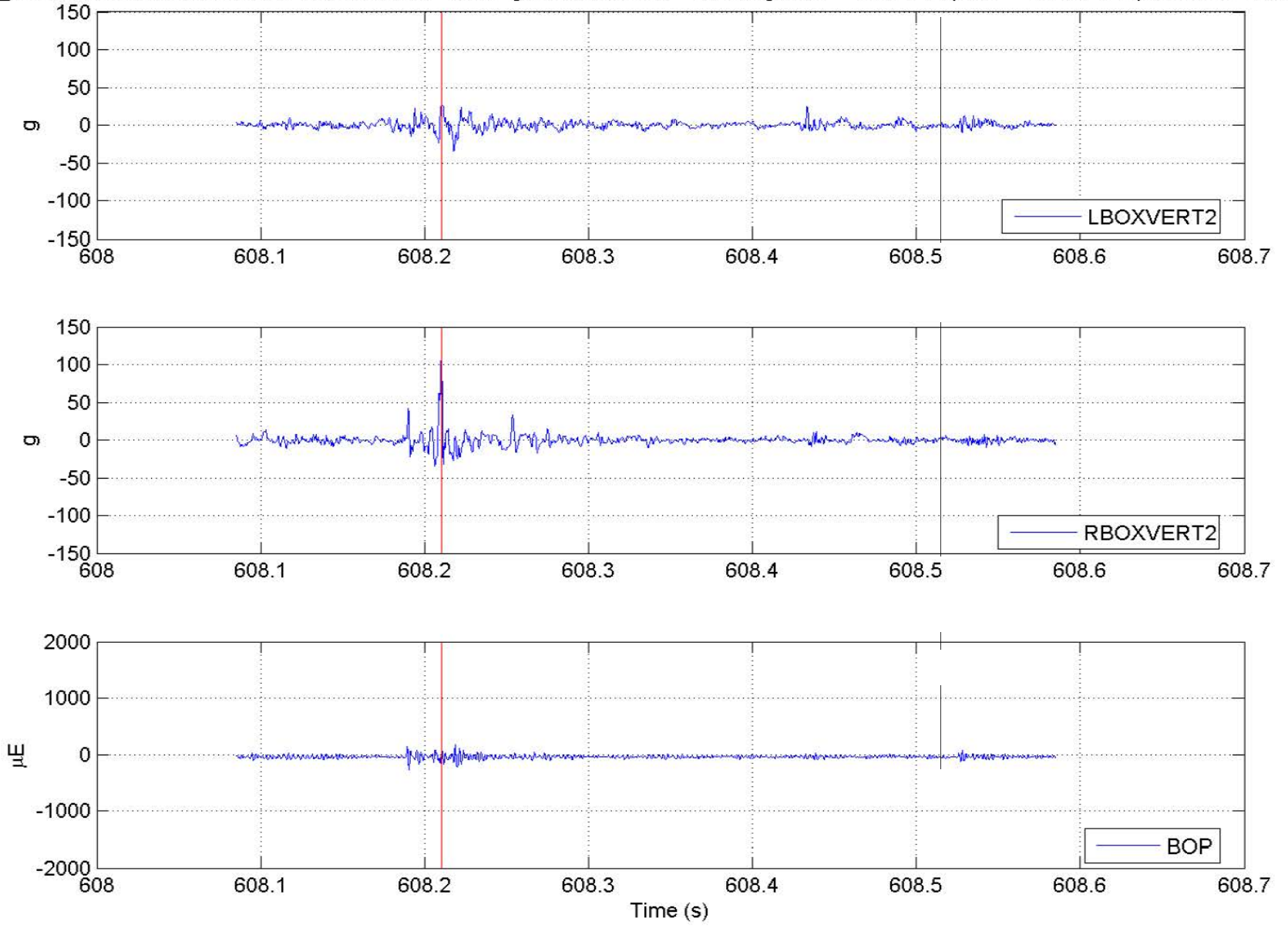

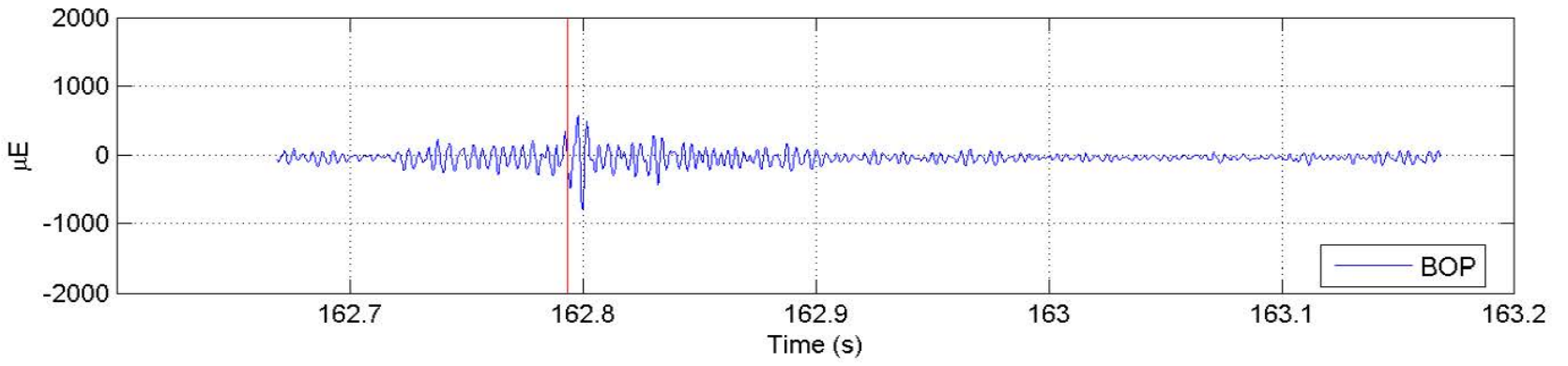
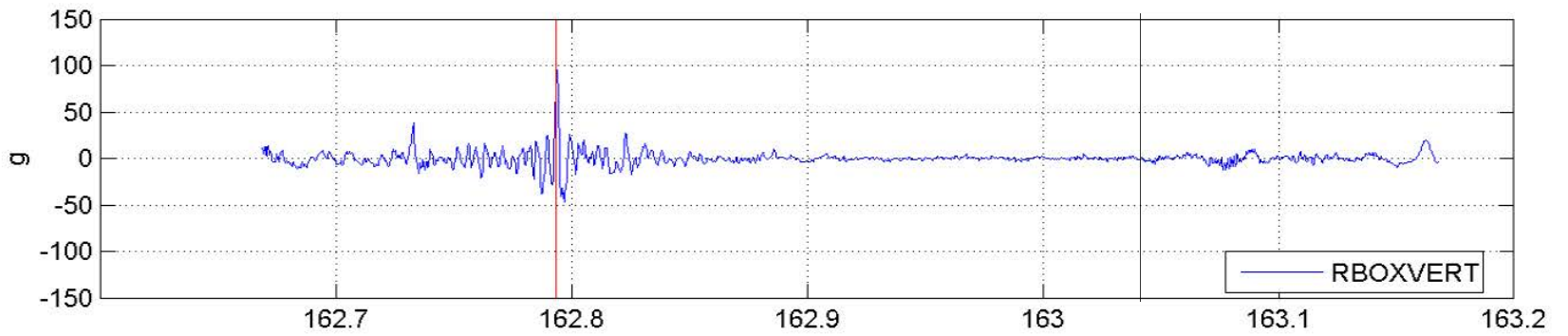
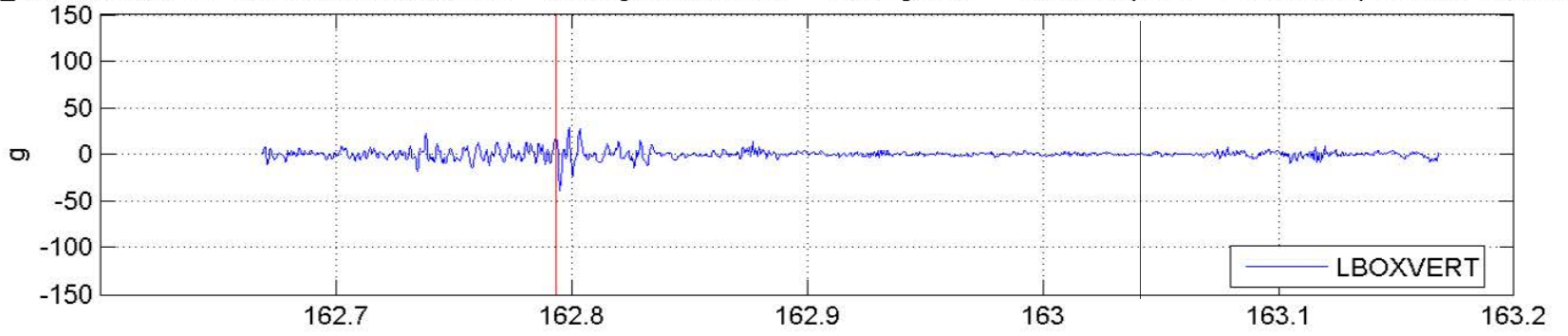

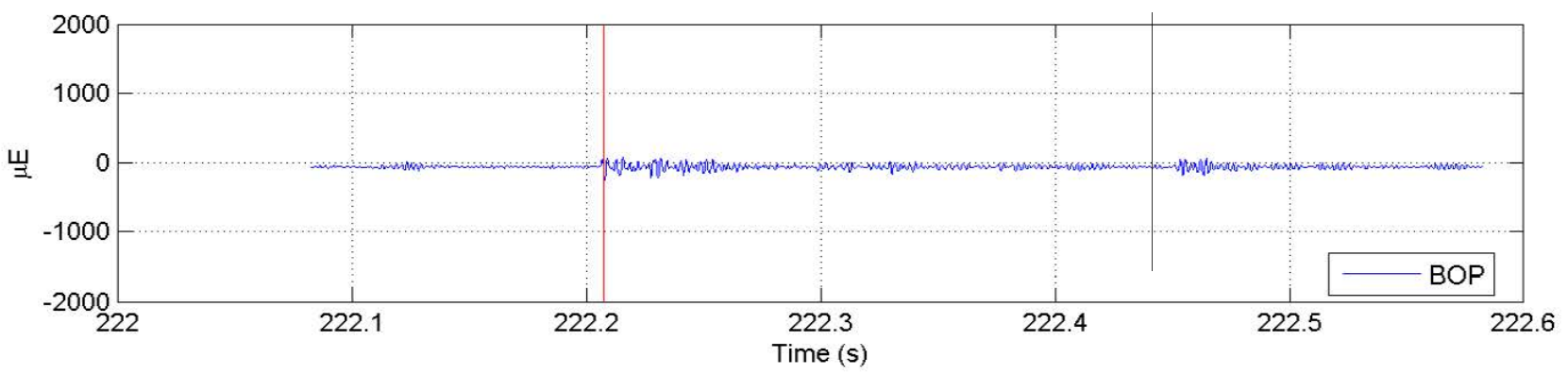
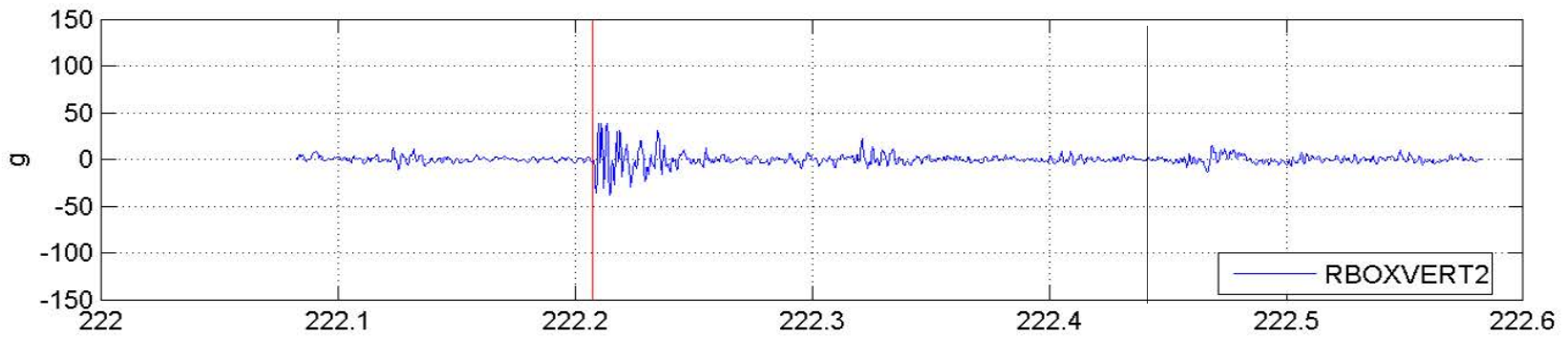
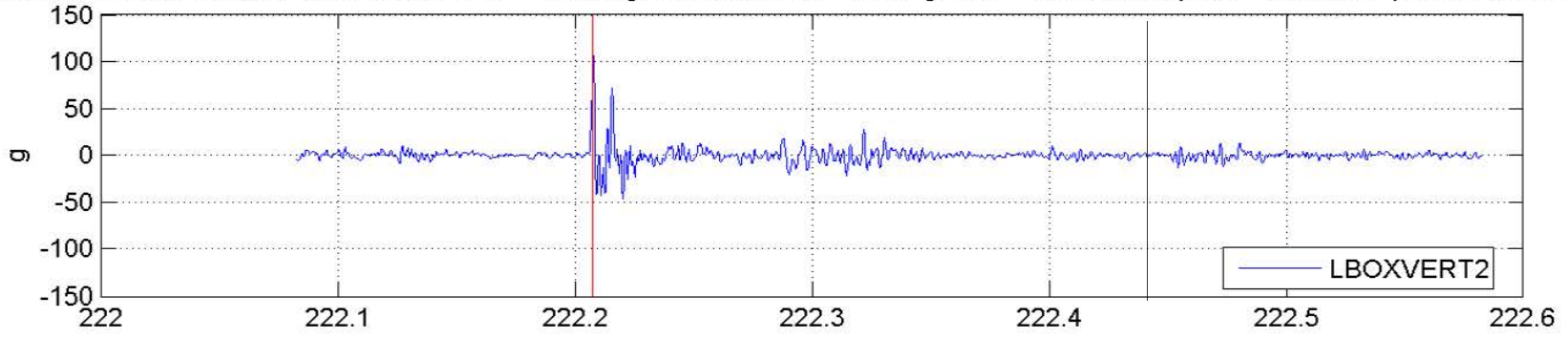

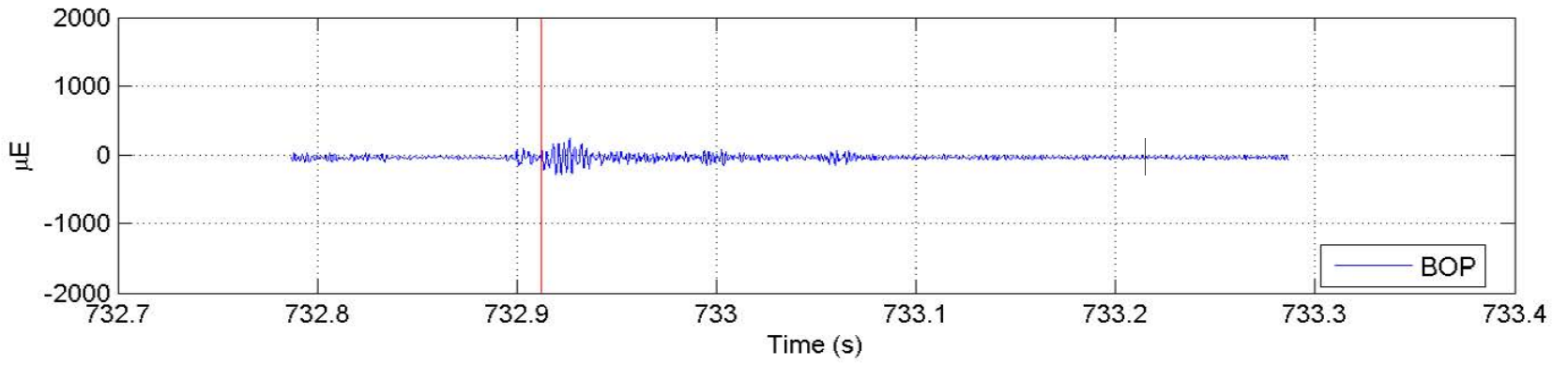
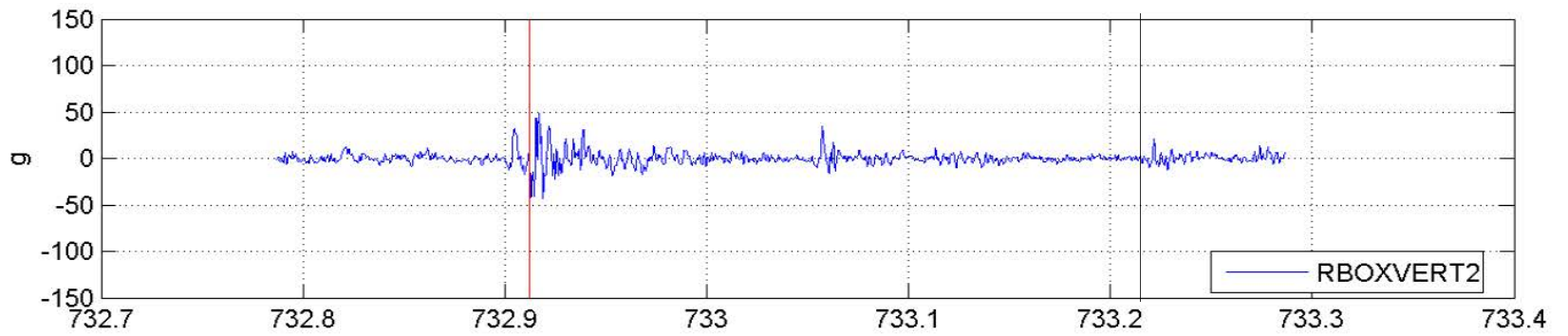
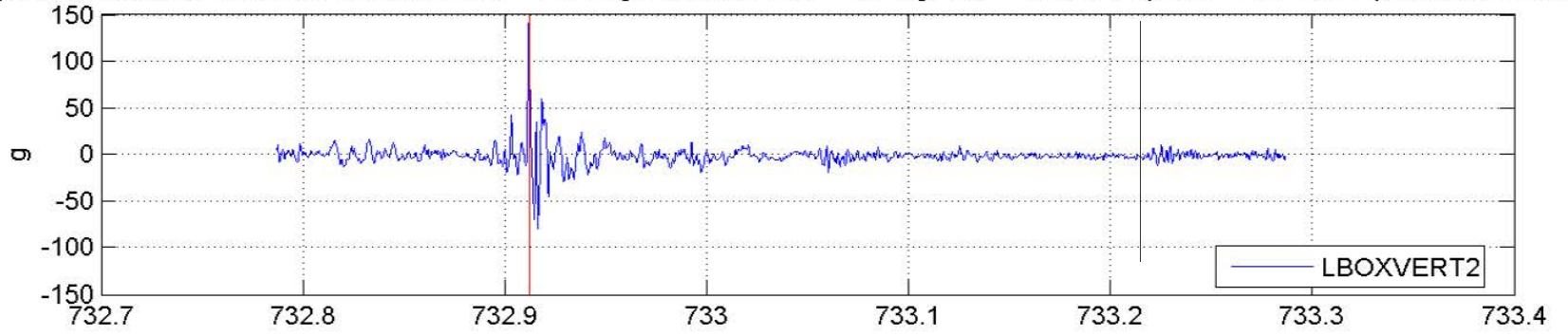

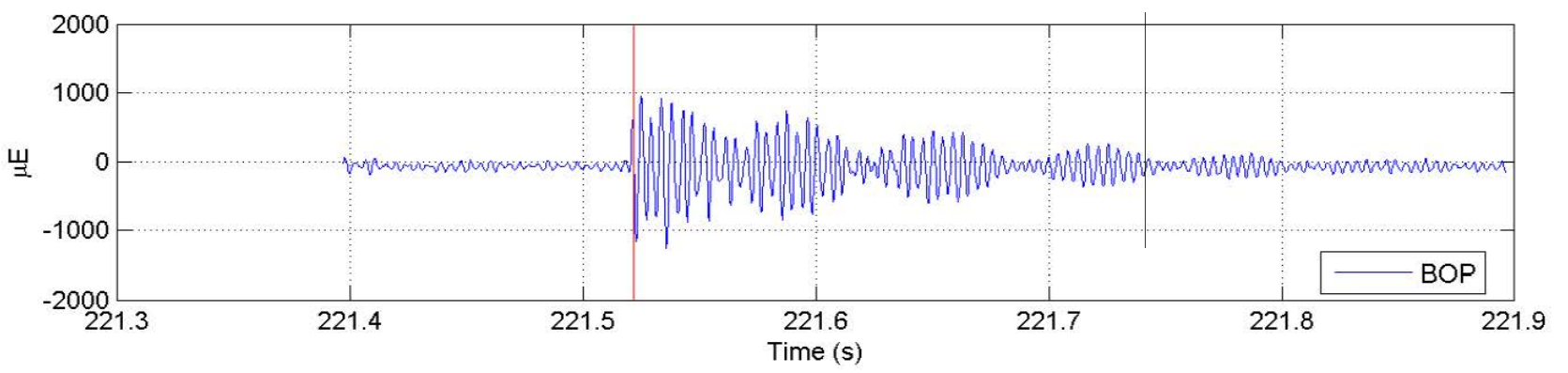
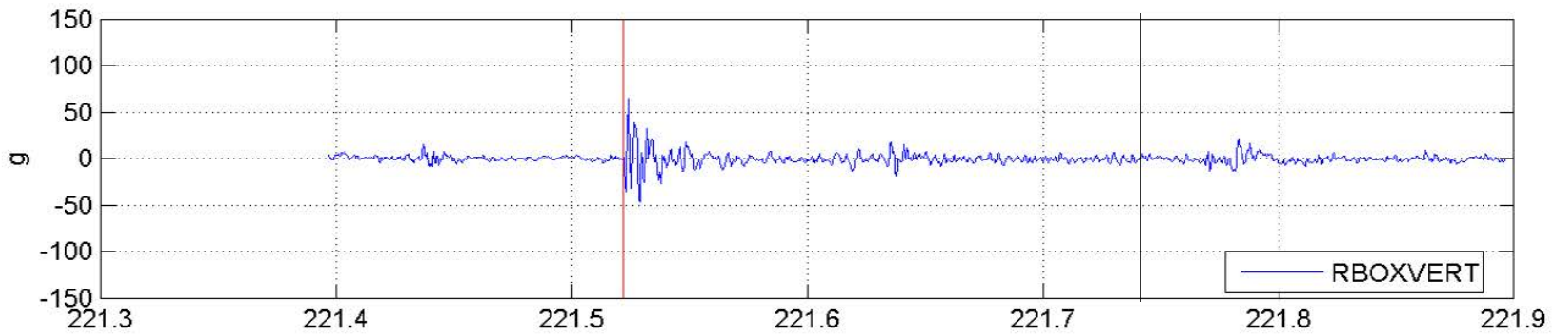
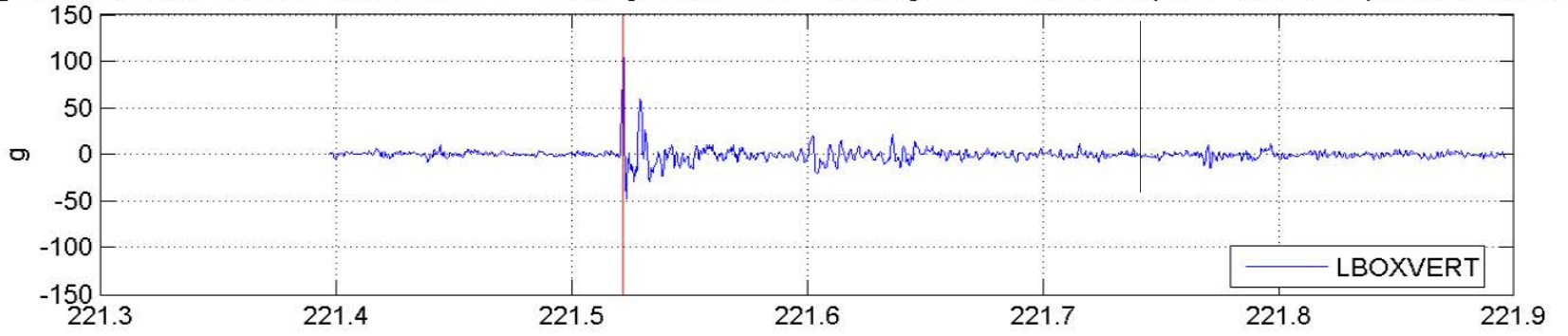

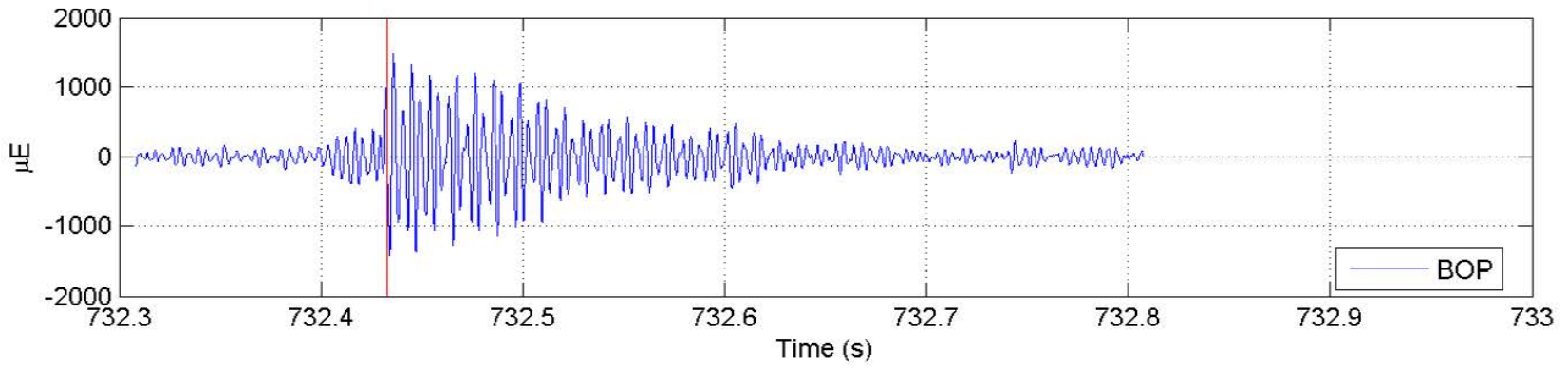
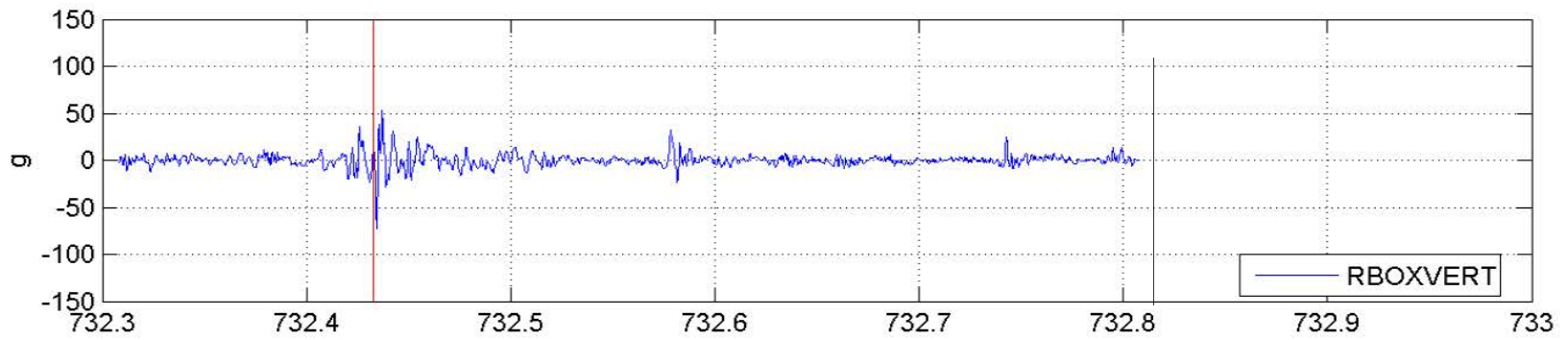
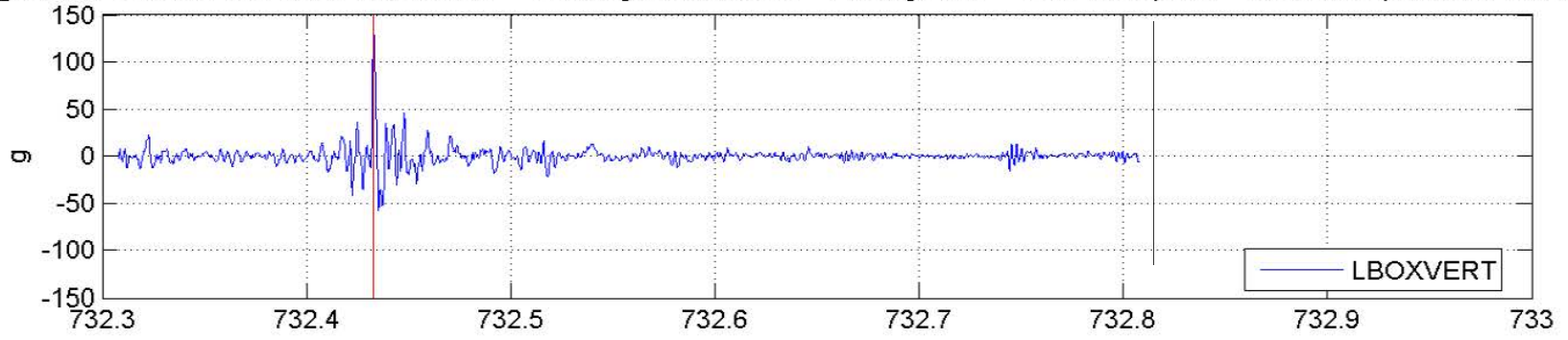

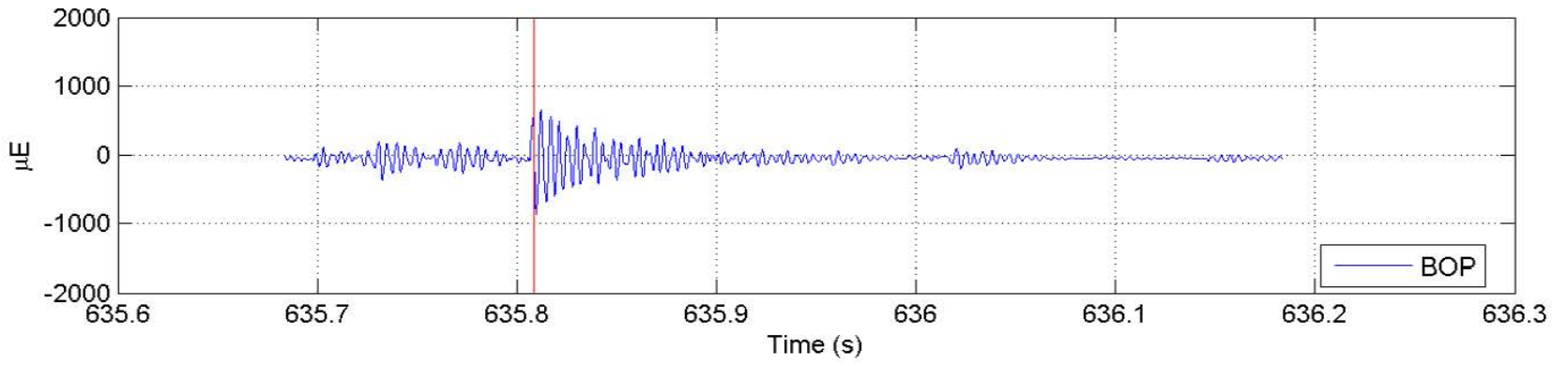
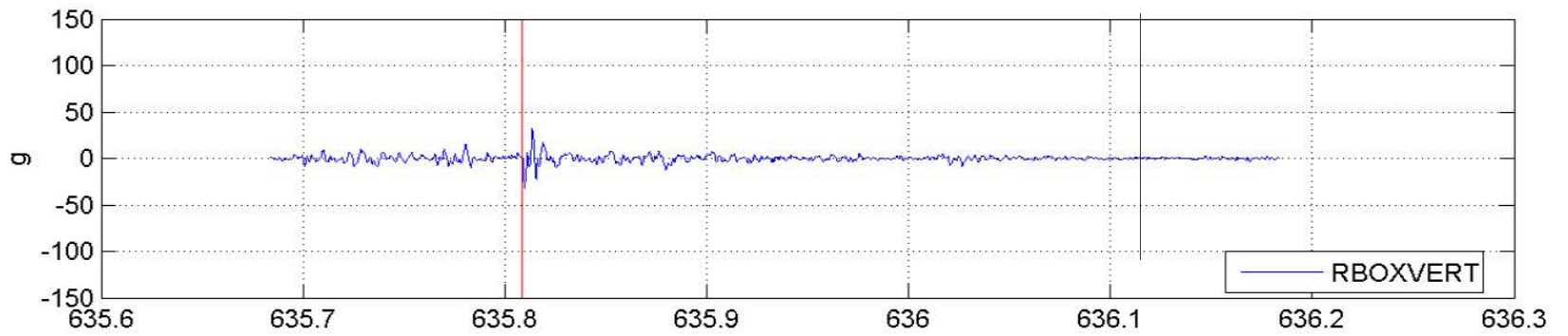
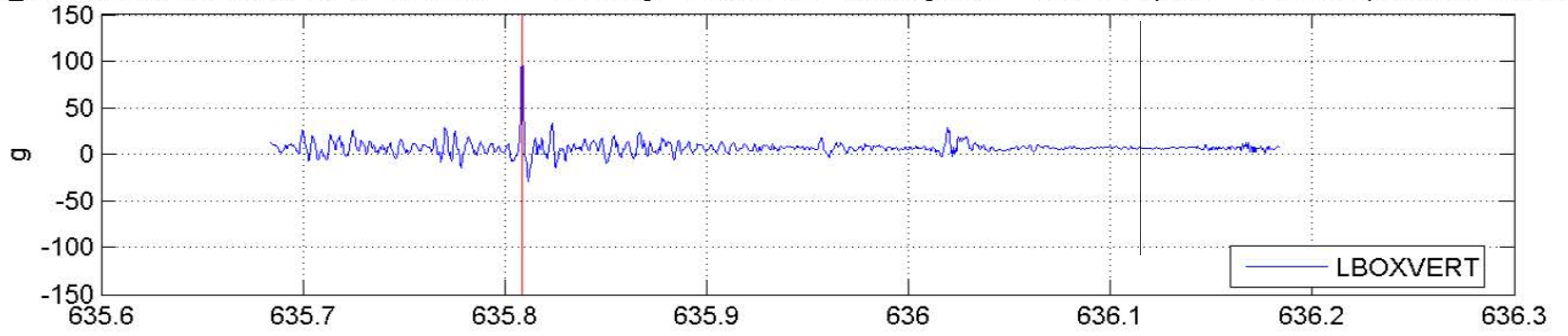

Appendix G.

Spoke Strains

<u>Section</u>	<u>Page</u>
Introductory Comments	G-2
BOP Strains	G-24
Relationship of BOP Strain to Acceleration Difference	G-42
Estimate of Fatigue Effects and Goodman Plots	G-62

Introductory Comments

Basic Approach

- Combine Individual Strain Measurement into Strain Associated with:
 - Tension in Spoke (F1, F2, R1, and R2)
 - In-Plane Bending (BIP) of Spokes (F1 and F2)
 - BOP in Spokes (R1 and R2)
- Compare Test Results with Finite Element Analysis (FEA)
- Laboratory Testing to Support Analysis

Three Components

- Tension in Spoke (F1, F2, R1, and R2)
 - $\epsilon_T = (\epsilon_{F1} + \epsilon_{F2} + \epsilon_{R1} + \epsilon_{R2})/4$
- BIP of Spoke (F1 and F2)
 - $\epsilon_{BIP} = (\epsilon_{F1} - \epsilon_{F2})/2$
 - BIP = bending in plane
- BOP in Spoke (R1 and R2)
 - $\epsilon_{BOP} = (\epsilon_{R1} - \epsilon_{R2})/2$
 - BOP = bending out-of-plane
- These Three Strains Explain the Most Strain Seen at the Four Strain Gage Locations

Names

- BOP
 - Bending of the Spoke out of the Plane of the Disc
- BIP
 - Bending of the Spoke in the Plane of the Disc

General Observations

- Large Tensile Strain
 - The Tensile Strains Appear To Be Generated As The Friction Rings Heat Up, Expanding The Circumference Of Friction Ring, Causing Tension In The Spokes Which Resist The Expansion
 - The Thermal Time Constant Once The Friction Discs Are Heated During Braking Is 7 Minutes Or More—20 Minutes To Cool Down

General Observations

- BOP occurs during braking
 - Many times long sustained periods
 - Sustained oscillations only with axle in lead position
- BOP occurs during non-braking conditions
 - Usually short duration
 - Appears to be associated with vertical acceleration
- Frequency
 - ~187 Hz during braking
 - ~230 Hz non-braking conditions
- BIP strain
 - Small compared to BOP strain
 - Rarely greater than 100 μE
- Measurements modulated by wheel rotation rate

Strain Gage Locations

- WABTEC/SAB-WABCO Disc
 - On Spoke at Location Where Spokes Cracked
 - Four Locations
 - Two on out-of-plane side of spoke
 - Two on in-plane side of spoke
- Knorr Disc
 - Location Provided by Knorr
 - Four Locations
 - Two on out-of-plane side of spoke
 - Two on in-plane side of spoke

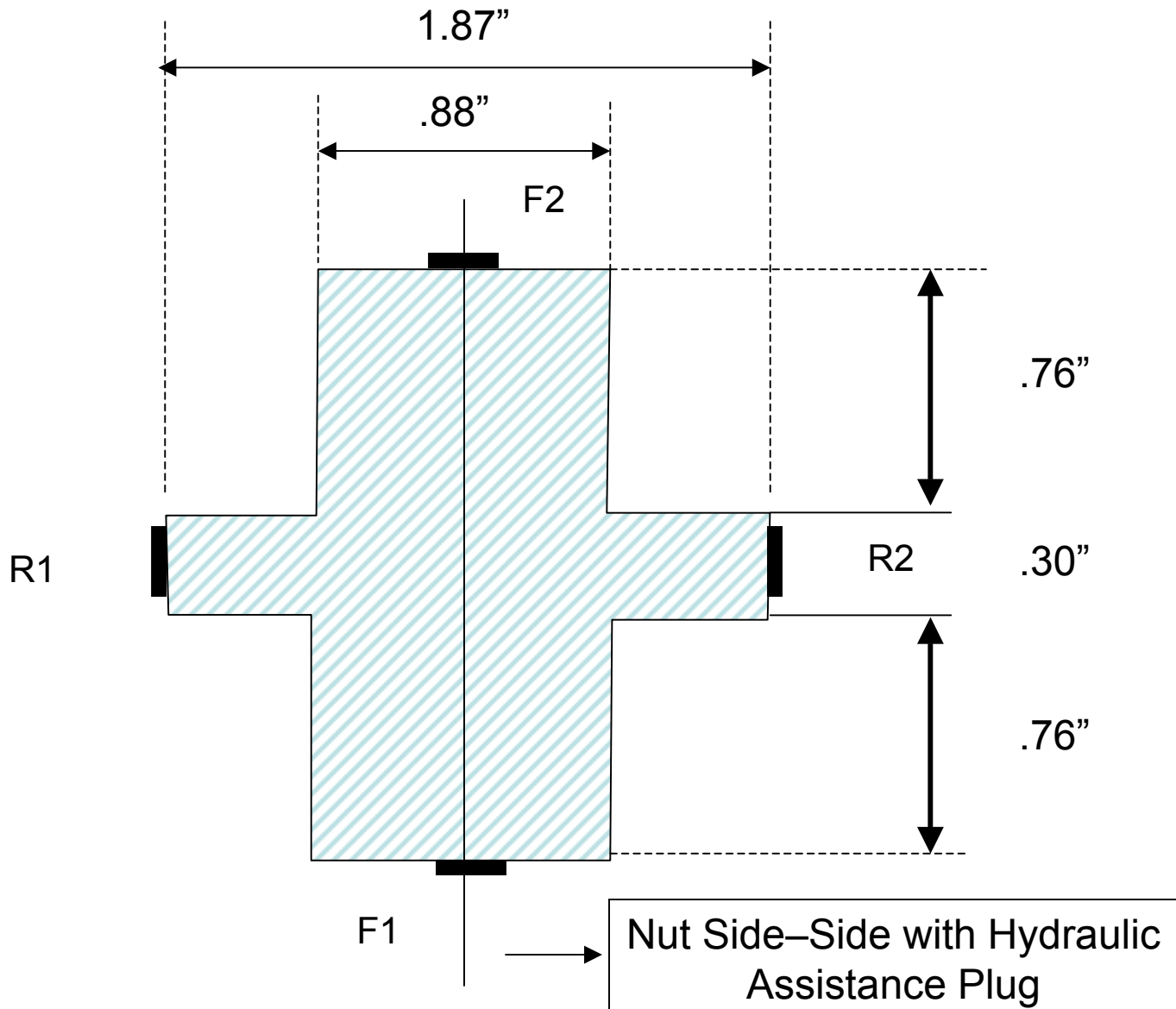

Plane Of Disc
WABTEC/SAB-WABCO Disc

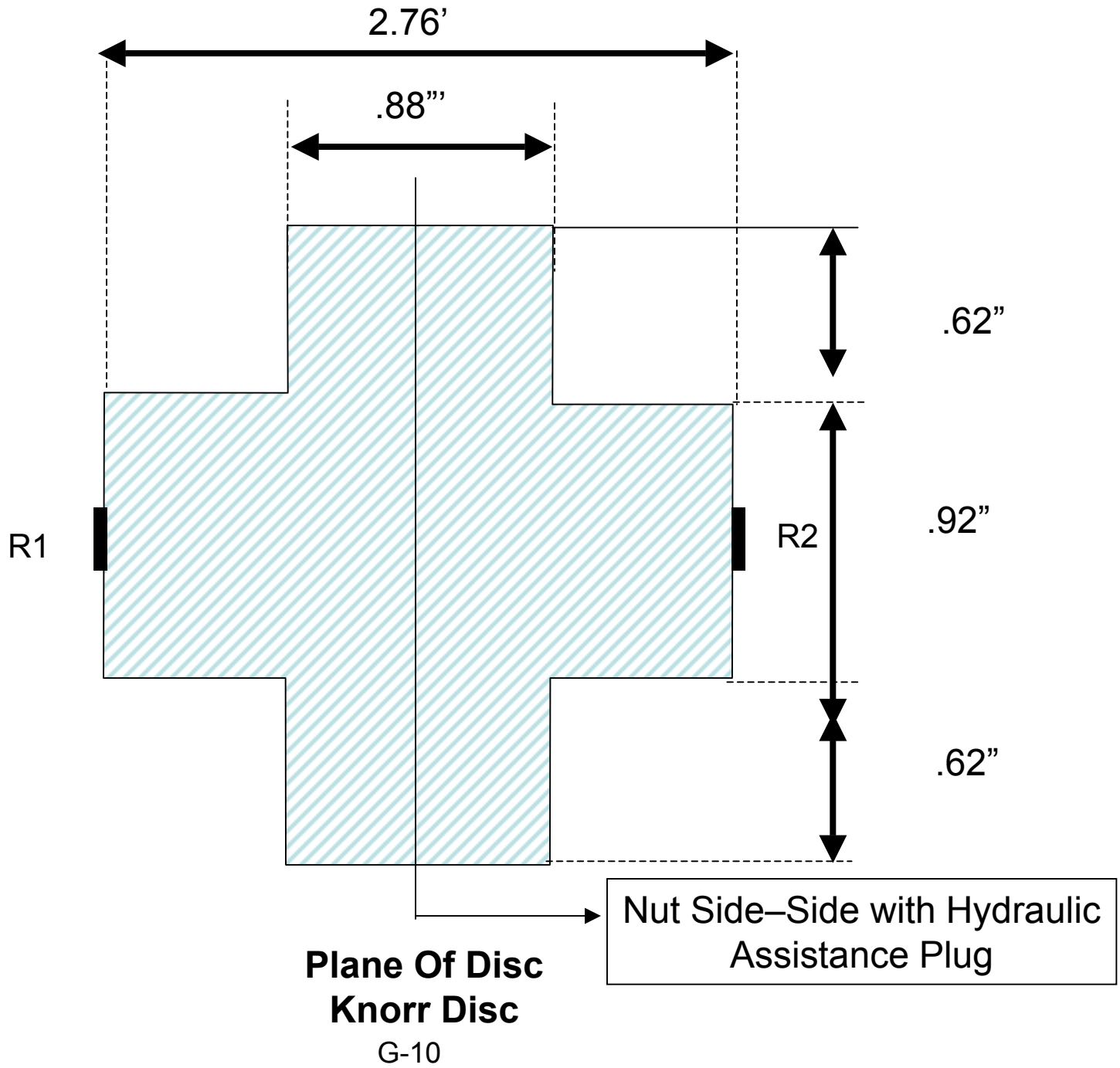

Approximate Cross Section
of WABTEC/SAB-WABCO Disc at Strain Gage
Location

Approximate Cross Section
of Knorr Disc at Strain Gage
Location

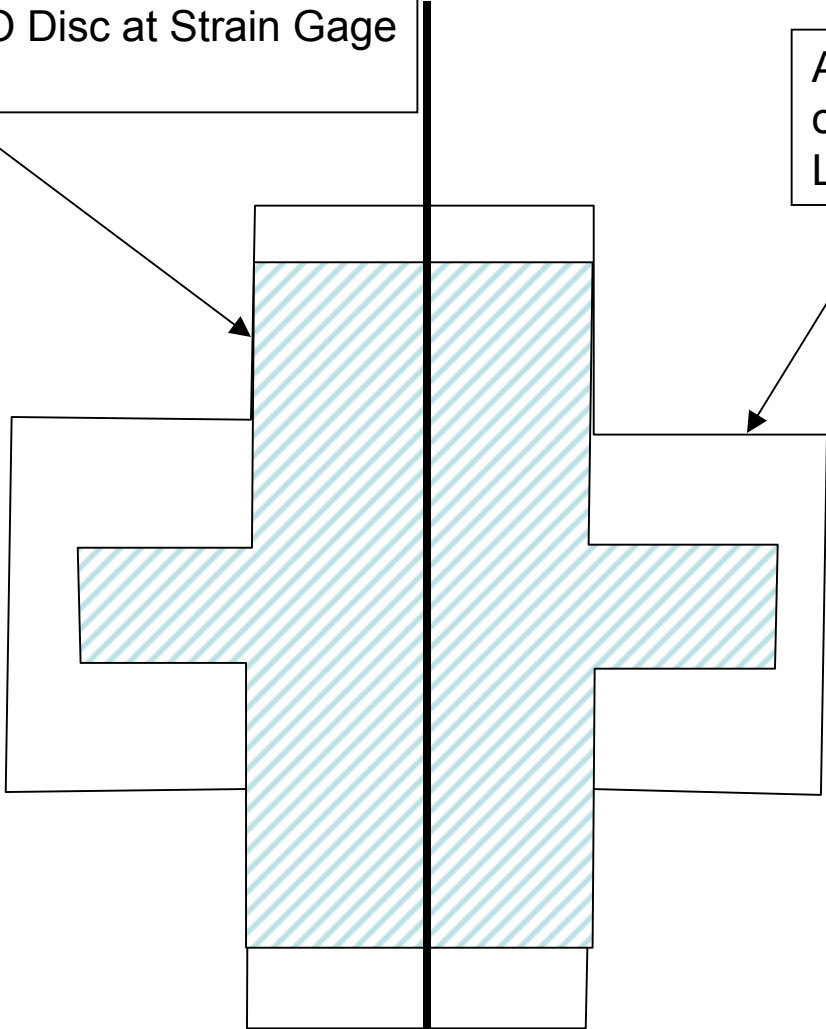

Plane of Disc

G-11

Table G.1. Spoke Cross Section Values

	WABTEC/SAB- WABCO	Knorr
Area	1.9 in ²	3.6 in ²
Moment of Inertia (bending in-plane)	0.44 in ⁴	0.85 in ⁴
Moment of Inertia (bending out-of-plane)	0.25 in ⁴	1.69 in ⁴

Bending In-Plane

$$\text{BIP} = (F1 - F2)/2$$

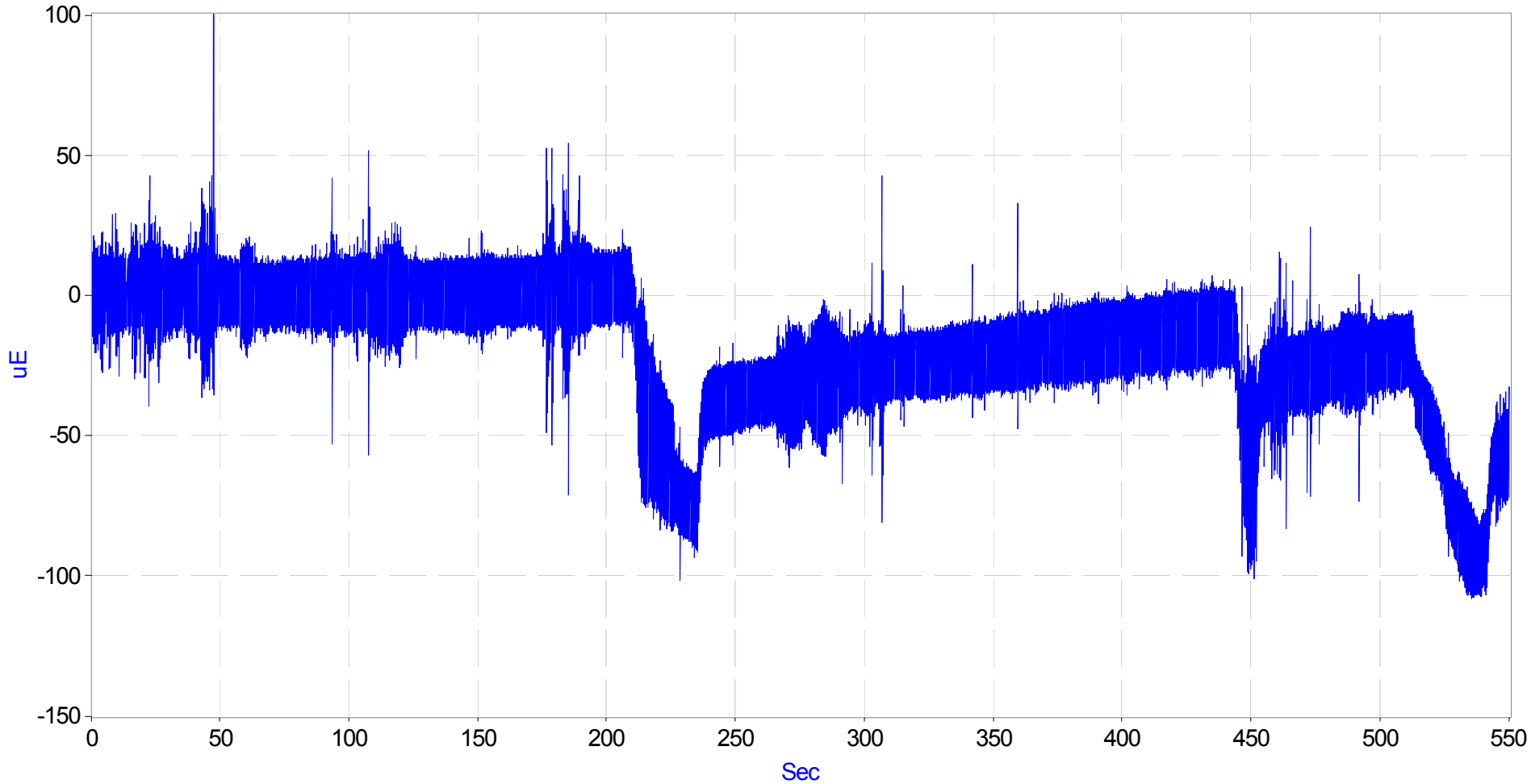

G-13

Bending Out-Of-Plane

- In The First Days Of Testing Large Oscillations At ~ 187 Hz Were Observed
- The Question Was Whether This Oscillation Was In The Plane Of The Disc Or Out Of The Plane
- The Effect Of BOP Being Modulated By Wheel Rotation Rate Is Investigated In The Next Series Of Slides
- Later In The Testing Program Strain Gages Were Added To Spoke 3 (Diametrically Opposed To The Initial Instrumented Spoke 6) And Demonstrated The Out-Of-Plane Behavior

Wheel Rate Modulation

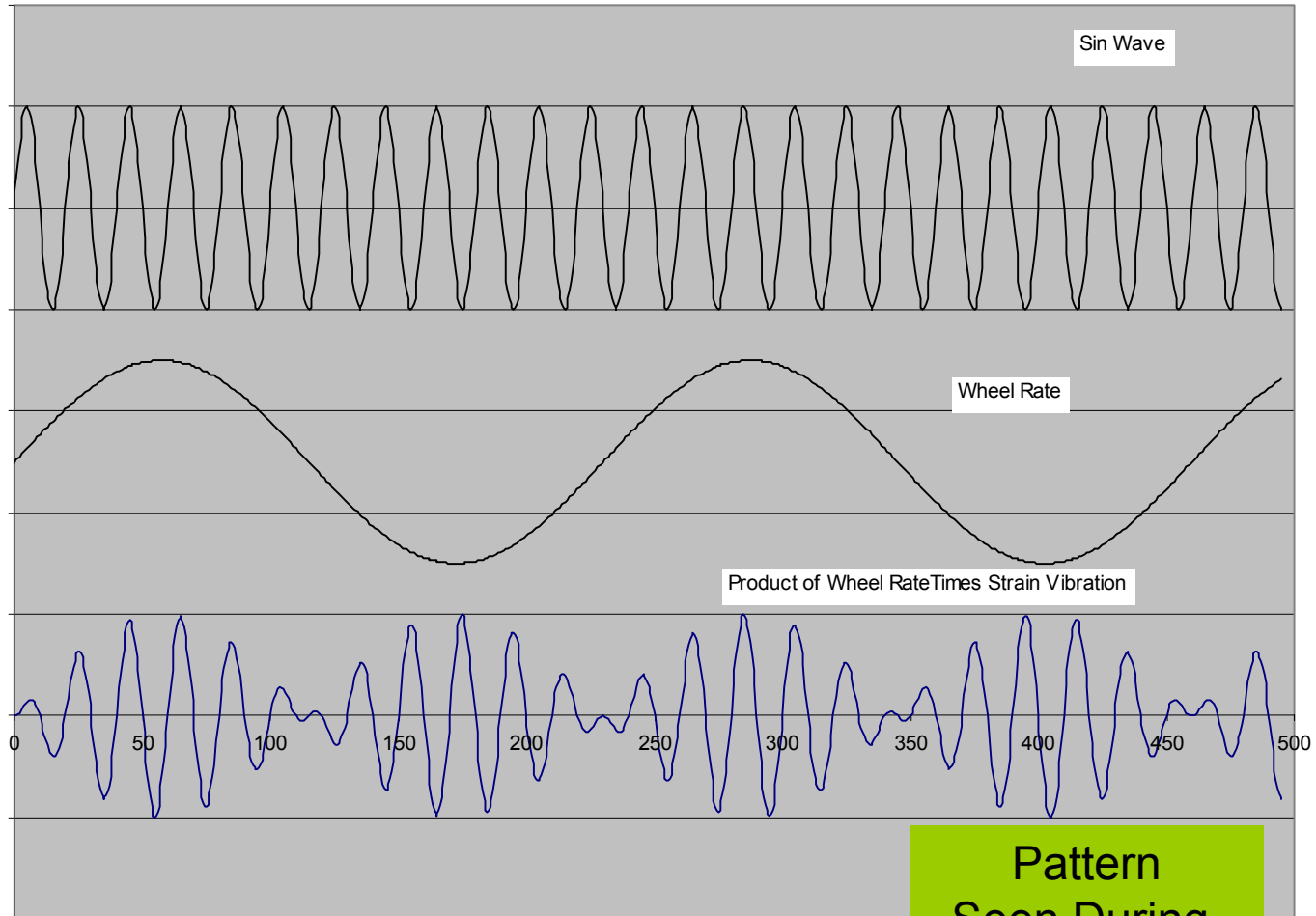

**Pattern
Seen During
Braking in BOP
Strain**

Frequency Domain Analysis of Modulated BOP Strain

$$\sin(2\pi Ft) * \sin(2\pi Wt)$$

$$= -0.5 * \cos\{2\pi(F+W)t\} + 0.5 * \cos\{2\pi(F-W)t\}$$

F = Strain Signal Frequency

W = Wheel Rate

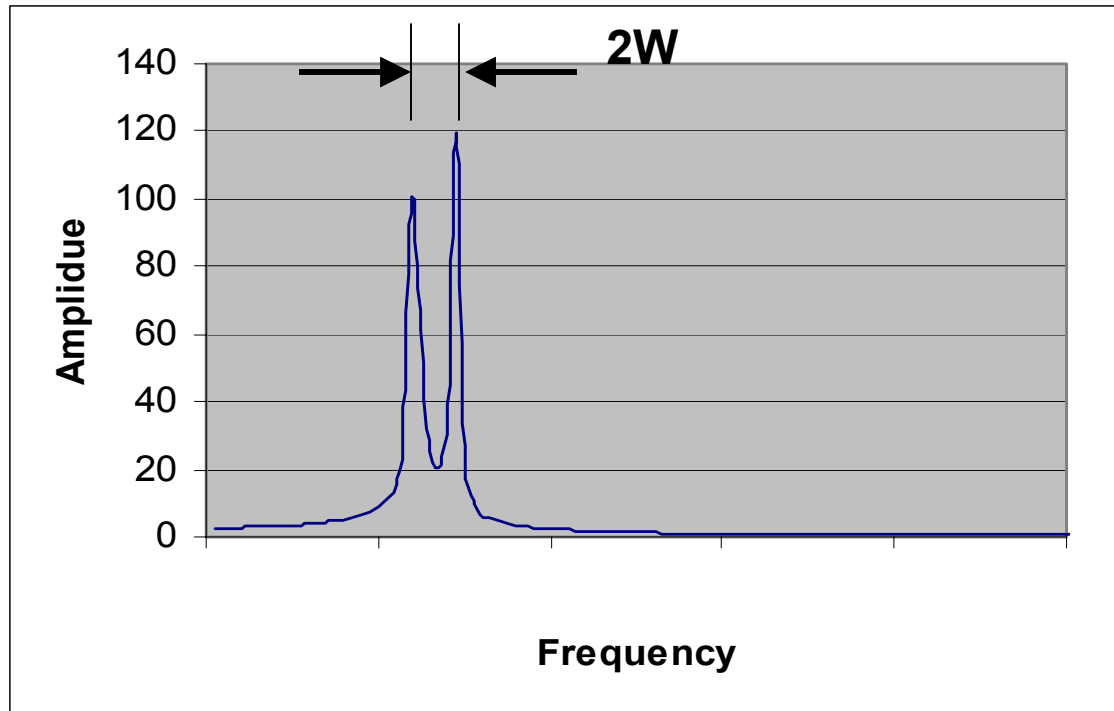

Spoke Location

- The Slip Ring Used To Transfer Signals From The Rotating Axle And Disc Contains A Sine Wave Generator (One Cycle Per Wheel Revolution)
- A Test Was Performed To Determine The Phase Of This Signal With The Position Of The Instrumented Spoke
- This Information Is Important In Determining The Axis Of Rotation Of The Disc
- Results Are Shown In The Next Slide

Instrumented Spoke Phase Based on Wheel Position

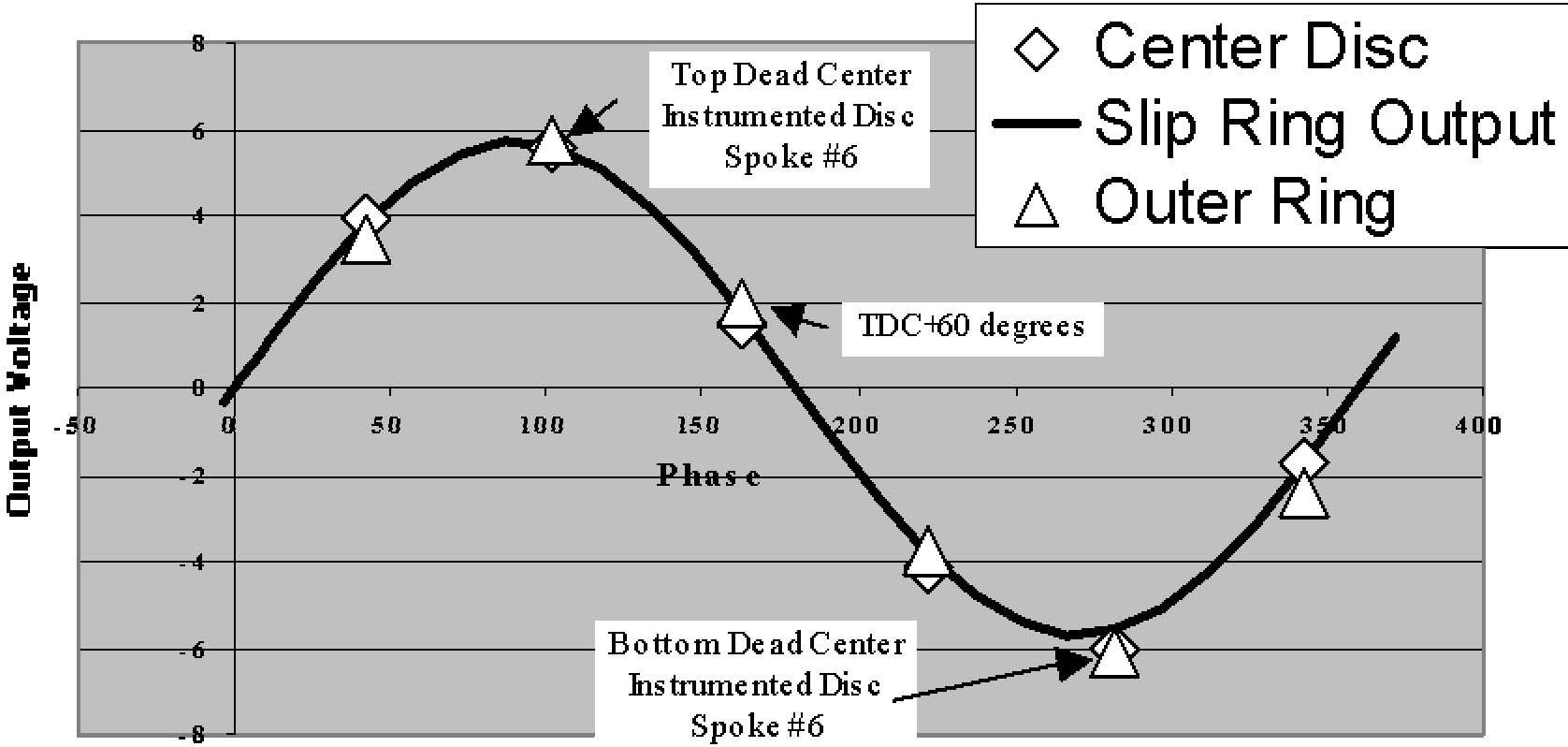

extract(w10, 3108*2000, 2000); overlay(extract(w7, 3108*2000, 2000))

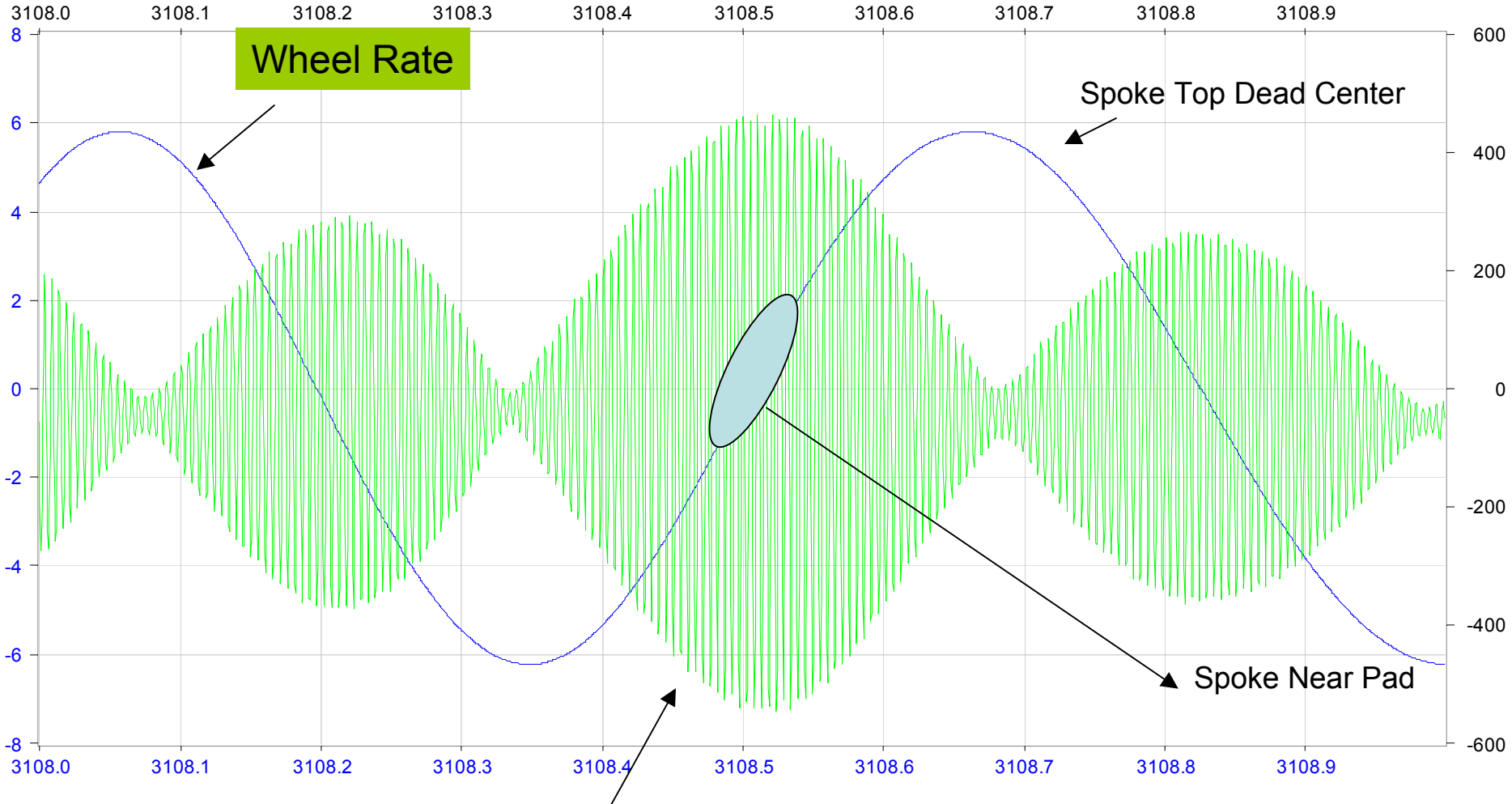

Wheel Rate

Spoke Top Dead Center

Spoke Near Pad

ϵ_{BOP}

During Braking

Look Down on Disc

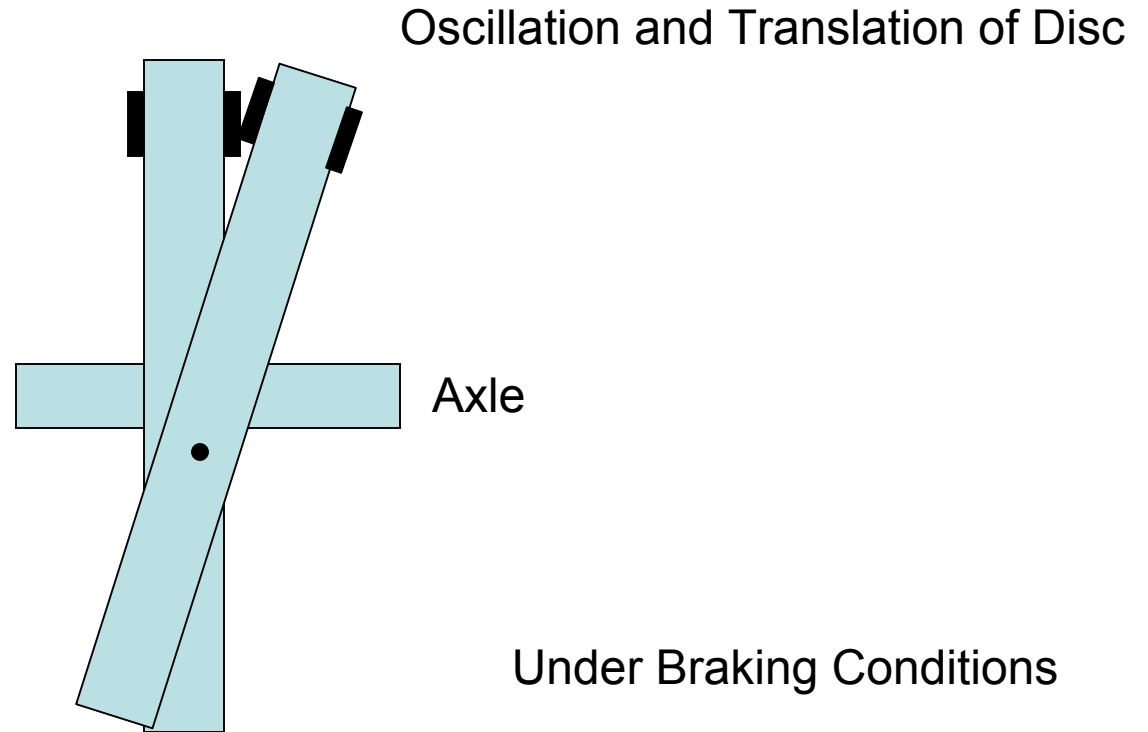

Caliper Displacement

- The Amplitude Of The BOP Oscillation During Braking Was Estimated By Observing The Amplitude Of The Lateral Acceleration Of Brake Pad
- Acceleration Level = 20 G's = $D\omega^2$
- Frequency = 192.4 Hz = 1,209 Radians Per Second
- Displacement = .005 Inches

`extract(w10, 4981000, 1000); overlay(extract(w7, 4981000, 1000))`

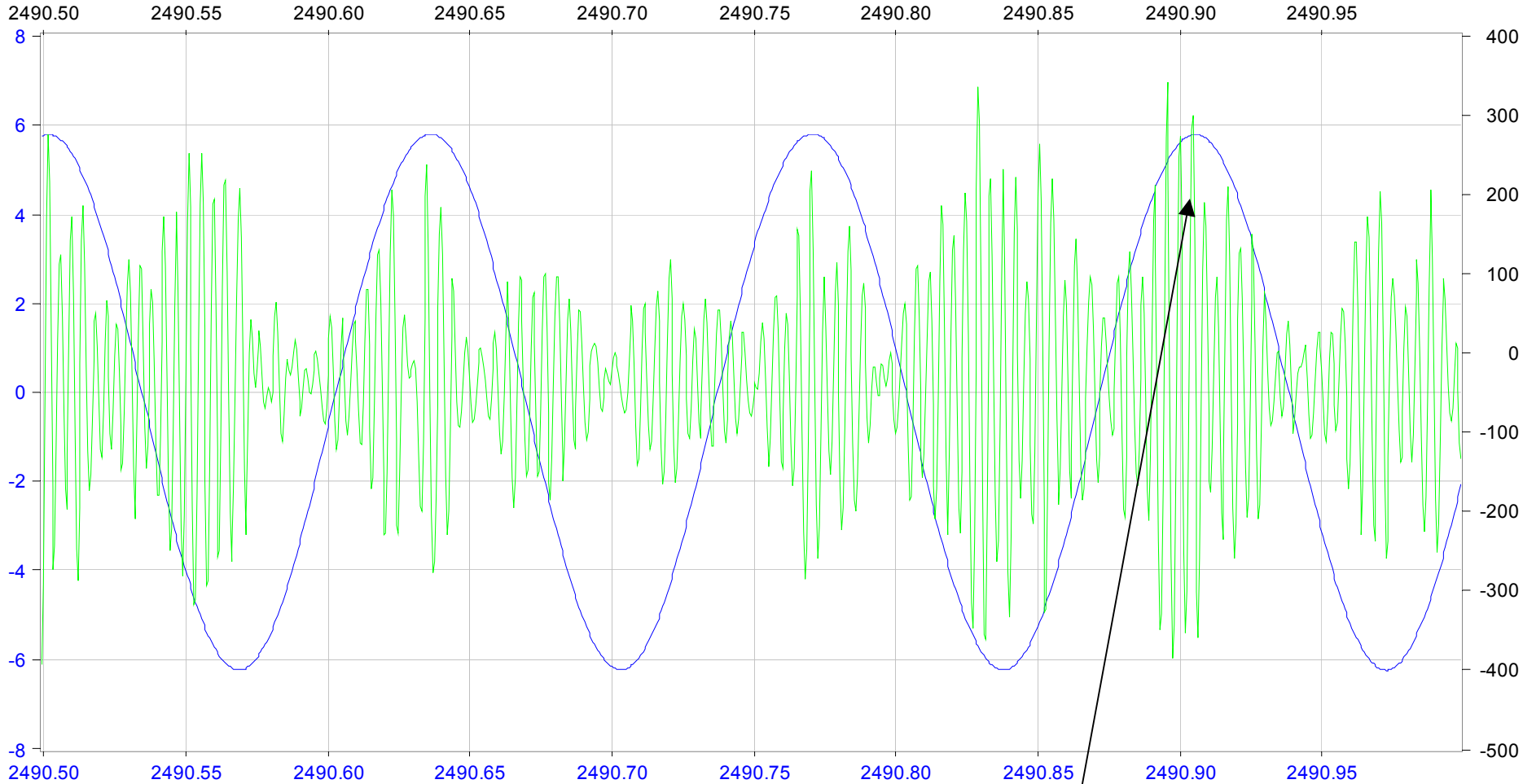

Non-Braking Conditions
Strain Amplitude When Spoke
Is Near Top Dead Center

G-22

Look From Front

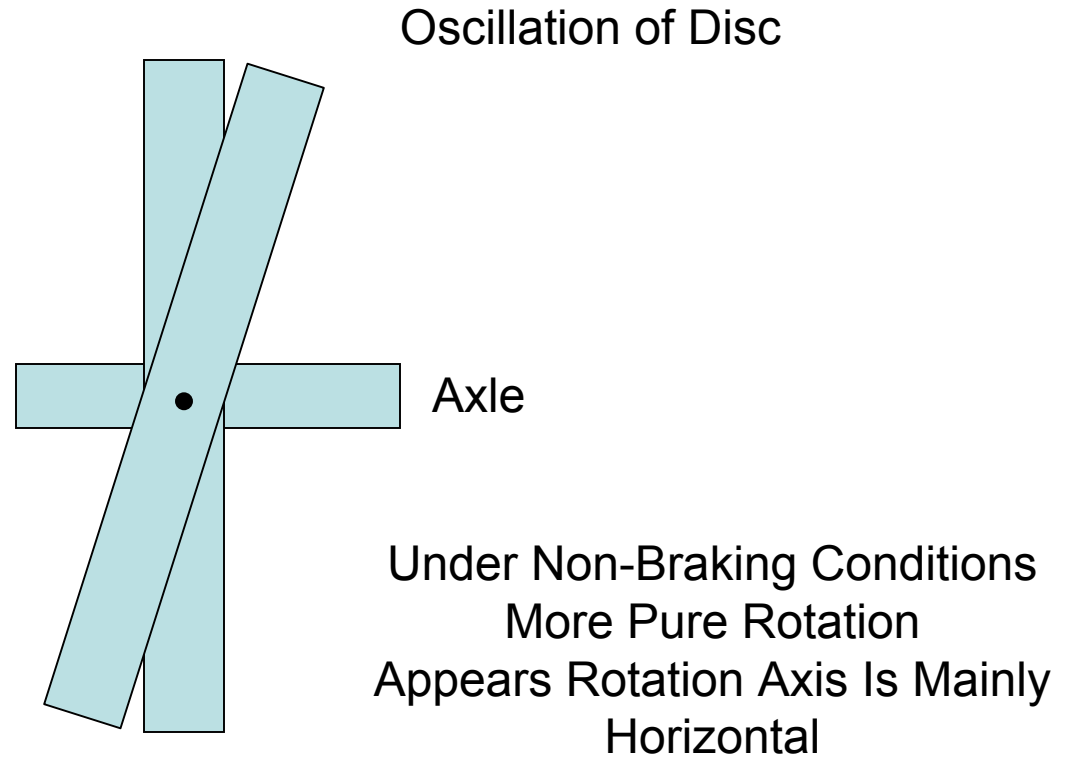

BOP Strains

BOP Strain

- Large BOP Strain
 - Condition 1: Input From Vertical Acceleration Observed On The Outer Bearing Housing Leads To A Ring-Out At ~230 Hz In The BOP Mode
 - Condition 2: During Braking With Instrumented Axle In Lead Leads To Sustained Oscillation On The BOP Mode At ~187 Hz—Since This Occurs During Braking, Mean Strain Values Are Increasing
- Both May Contribute To Fatigue Damage Of The Spoke

Sustained Oscillations And Track Related Oscillations

- Track Related Inputs Occur Continuously
- Track Related Responses (e.g., BOP Strain) Are Continuous But May Be Small During A Great Deal Of The Test
- The Sustained Oscillations Occur Infrequently During The Test But Produce A Large Number Of Oscillations
- During Sustained Oscillations, Response Is The Combined Effect Of Track Related Response And The Oscillations Induced By Braking

Example of Large BOP Strain During Braking

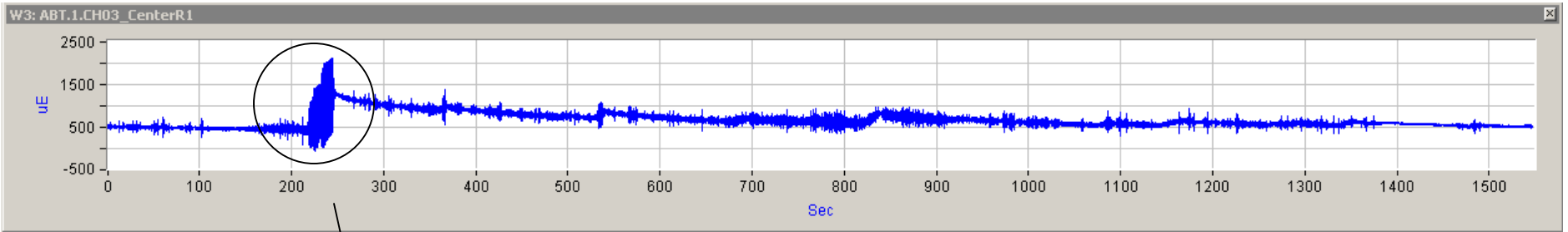

Center R1

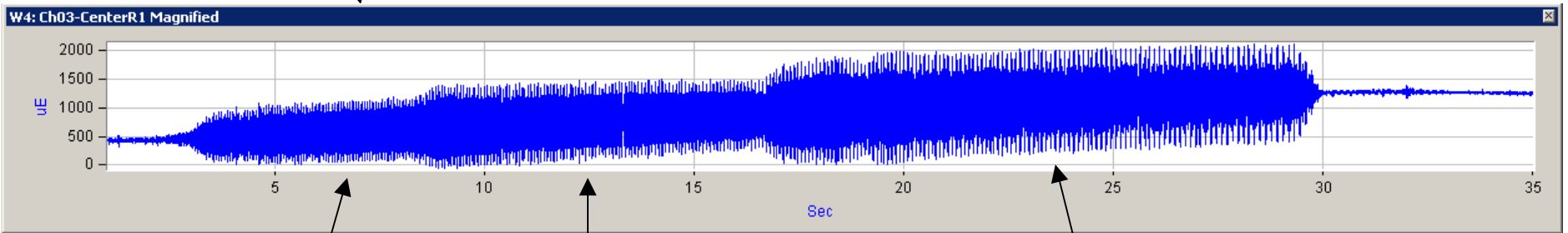

Brake Cylinder Pressure

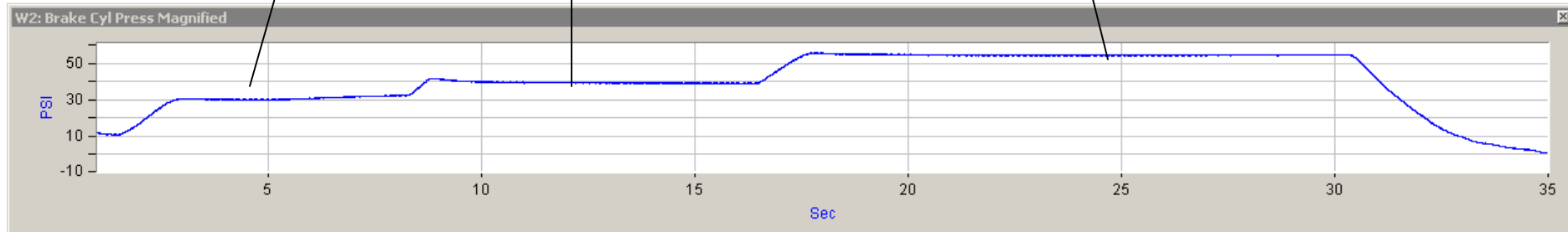

Note: The Relationship of BOP Strain and Brake Cylinder Pressure

Sustained Oscillation Data

- First Task Was To Identify Location Of Sustained Oscillations And Characterize General Behavior
- Simple 3 Parameter Model
 - Mean Stress At Beginning Of Sustained Oscillation Period
 - Mean Stress At End Of Sustained Oscillation Period
 - Maximum Alternating Strain During Sustained Oscillation Period
- More Detailed Analysis Is Required To Investigate The Fatigue Implications Of These Oscillations

Table G.2. Summary Of Significant Sustained BOP Oscillations During Braking

Direction	Instrumented Axle Leading or Trailing	Number of Sustained Events	Number of Brake Applications	Range of Brake Cylinder Pressures (psi)	
North	Trailing	0	103		
South	Leading	7	76	31	45
North	Leading	11	82	30	40
South	Trailing	0	98		
North	Leading	24	147	23	55
South	Leading	9	95	35	56
	Total	51	601		

Terms Used To Describe Sustained Oscillations

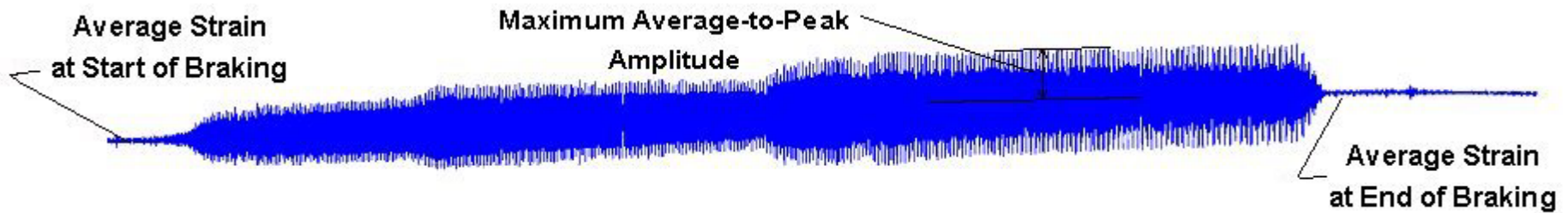

Table G.3. Significant Sustained Oscillations During Braking—May 17, 2005

17-May Bos-Was 7in CD Instrumented Axle Leading

Geographic Location	File	Time Span in the File (secs)	Time Duration in Secs	Max Avg-to-Peak Strain	Avg Strain @ Start	Avg Strain @ End	Speed (mph)	Brake Cyl Press	Temp at Start °F	Temp at End °F	Peak Temp °F
1685 SW of MP E17	File17	218 to 246	28	850 uE	445	1329	101	45 psi	136.7	184.6	229.0
190 SW of MP AN13	File19	142 to 164	22	711.5 uE	350	887	103	35 psi	116.0	163.5	189.9
Near N. Philadelphia	File19	3107 to 3114	7	502 uE	10.6	32.3	14	45 psi	183.3	187.7	193.0
516 SW of MP AP25	File20	1251 to 1257	6	622.5 uE	476	659	94	36 psi	109.9	122.6	172.8
2303 NE of MP AP65	File21	1204 to 1224	20	700 uE	785	1368	110	40 psi	127.5	186.4	242.2
947 NE of MP AP71	File21	1475 to 1507	32	591 uE	950	1702	119	37 psi	172.3	227.3	283.1
1573 W of MP AP91	File21	2392 to 2404	12	502 uE	617	886	70	32 psi	131.4	136.7	181.5
471 SW of MP AP79 Gunpow	File21	2019 to 2022	3	576 uE	875	958	123	31 psi	160.9	161.8	171.9

Table G.4. Significant Sustained Oscillations During Braking—May 26, 2005

26-May Was-Bos 7in CD Instrumented Axle Leading

Geographic Location	File	Time Span in the File (secs)	Time Duration in Secs	Max Avg-to-Peak Strain	Avg Strain @ Start	Avg Strain @ End	Speed (mph)	Brake Cyl Press	Temp at Start °F	Temp at End °F	Peak Temp °F
1429 SW of MP AN11	File05	2323 to 2339	16	706.5 uE	701	1142	103 mph	40 psi	107.3	134.1	161.8
15 NW of MP E13	File07	418 to 423	5	482.5 uE	393	503	64.26 mph	32 psi	82.6	102.9	137.6
2139 NE of MP E17	File08	157 to 177	20	665 uE	432	869	77 mph	34 psi	93.2	117.8	145.9
195 SW of MP MN59	File09	202 to 206	4	262 uE	353	453	64.69 mph	30 psi	77.4	90.1	140.7
642 E of MP AB84	File12	400 to 430	30	792.5 uE	257	1129	122 mph	35 psi	74.3	126.2	162.6
1108 E of MP AB89	File12	600 to 632	32	784 uE	697	1617	89.25 mph	36 psi	134.1	186.8	217.2
1240 E of MP AB116	File13	479 to 485	6	540.5 uE	734	873	79 mph	32 psi	129.2	138.9	156.9
1936 NE of MP AB158	File15	984 to 1028	44	971.5 uE	391	1764	150.2 mph	40 psi	85.3	185.9	222.9
2230 S of MP AB179	File15	1579 to 1596	17	795.5 uE	650	1301	137 mph	38 psi	109	128.8	161.8
1939 SW of MP AB204	File17	114 to 119	5	766 uE	409	657	130 mph	33 psi	80	83.5	96.7
1732 NE of MP AB216	File17	451 to 473	22	542 uE	678	1124	83.8 mph	36 psi	87.5	145.5	187.3

Table G.5. Significant Sustained Oscillations During Braking–June 17, 2005

Geographic Location	File	Time Span in the File (secs)	Time Duration in Secs	Max Avg-to-Peak Strain	Values for Peak and Valley [uE]	Avg Strain @ Start	Avg Strain @ End	Speed (mph)	Brake Cyl Press	Temp at Start °F	Temp at End °F	Peak Temp °F
2089 NE of MP AP4	File10	206.5 to 209	3.5	531.5	675 to 1738	1282	1348	85	46	169.2	212.2	242.1
980 NE of MP MN21	File19	348 to 355	7	335	203 to 873	488	694	89	42	143.3	145.9	179.7
1627 NE of MP MN25	File21	151 to 165	14	327	261 to 915	528	766	73	32	152.5	158.6	181
772 E of MP MN28	File21	310 to 314	4	316	296 to 928	611	646	67	29	158.6	158.6	169.2
2599 E of MP MN45	File23	164 to 169	5	185.5	455 to 826	604	677	69	23	146.8	147.2	155.6
582 SW of MP MN59	File24	264 to 270	6	276.5	319 to 872	478	611	68	31	130.1	134	179.3
1163 W of MP MN64	File25	227 to 236	9	288	288 to 864	470	633	70	28	136.7	138.9	156.4
1530 SW of MP MN68	File25	490 to 499	9	314	335 to 963	528	704	74	30	144.6	145.9	157.8
49 E of MP MN69	File25	556 to 568	12	394.5	352 to 1141	665	861	72	34	149	162.6	178.4
717 NE of MP MN70	File25	631 to 640	9	333.5	538 to 1205	750	930	71	32	168.7	170.5	188.9
1022 E of MP AB99	File29	121 to 132	11	658	167 to 1483	756	1035	120	44	144.6	148.5	170.1
1768 E of MP AB102	File29	244 to 250	6	290	592 to 1172	770	922	85	35	164.8	163	180.6
1525 NE of MP AB115	File30	561 to 575	14	1010	-261 to 1759	580	1038	81	43	138.4	147.6	167.9
No GPS	File31	92 to 98	6	525.5	515 to 1566	984	1081	83	41	190.3	190.7	204.3
No GPS	File31	166 to 172	6	403	807 to 1613	1172	1280	78	31	203.9	203.9	221.9
821 SE of MP AB125	File32	334 to 338	4	255.5	743 to 1254	938	1005	66	29	204.8	204.8	213.6
639 SE of MP AB126	File32	387 to 393	6	658	486 to 1802	1004	1176	71	41	211.4	211.4	215.3
2129 SE of MP AB128	File33	72 to 78	6	899	445 to 2243	1142	1486	94	44	214.9	232	266.3
29 NE of MP AB131	File34	90 to 110	20	378.5	915 to 1672	1218	1520	95	37	224.5	236.4	250.5
2136 SW of MP AB138	File34	411 to 426	15	719	408 to 1846	1015	1413	90	40	189.4	242.6	245.2
673 SW of MP AB140	File35	70 to 90	20	749	731 to 2229	1272	1710	92	51	221	276.4	278.2
464 W of MP AB143	File36	131 to 144	13	1138.5	366 to 2643	1170	1686	107	50	222.3	227.2	247
2455 NE of MP AB158	File37	46 to 93	47	1371.5	-361 to 2382	658	2202	148	55	144.1	310.7	330
2579 NE of MP AB160	File38	546 to 557	11	590.5	308 to 1489	520	996	141	33	130.5	134	179.3

Table G.6. Significant Sustained Oscillations During Braking—June 18, 2005

Geographic Location	File	Time Span in the File (secs)	Time Duration in Secs	Max Avg-to-Peak Strain	Values for Peak and Valley [uE]	Avg Strain @ Start	Avg Strain @ End	Speed (mph)	Brake Cyl Press	Temp at Start °F	Temp at End °F	Peak Temp °F
2396 NE of MP AB202	File03	476 to 498	22	947.5	387 to 2282	1309	1918	116	56	100.6	253.5	252.7
2619 S of MP AB178	File05	530 to 551	21	1226	-367 to 2085	438	1483	130	52	115.6	244.3	243.4
691 SW of MP AB170	File06	242 to 258	16	558.5	768 to 1885	971	1406	113	35	169.2	198.2	225
4 SW of MP AB162	File06	503 to 540	37	1200.5	-214 to 2187	650	2154	150	54	145.4	266.3	298.8
1222 SW of MP AB159	File07	32 to 56	24	1132	540 to 2804	1491	2315	120	54	249.6	301.4	327.8
732 SW of MP AB156	File07	153 to 180	27	835	1051 to 2721	1719	2512	120	52	282.5	314.6	341.9
784 SW of MP AN13	File22	211 to 226	15	1128.5	-687 to 1570	285	925	110	55	107.2	156	199.9
1211 SW of MP AN19	File22	446 to 453	7	1171.5	-442 to 1901	643	938	120	51	143.3	148.5	179.3
1748 SW of MP AN55	File24	578 to 595	17	1454.5	196 to 3105	1466	1974	133	56	226.7	261.9	325.6

Outer Discs Versus Center Discs

- Sustained Oscillations Were Observed On The Outer And Center Discs During Test On May 17, Phase 1 Test
- When The Sustained Oscillations Were Observed On One Disc, They Were Also Observed On The Other
- The Magnitude Of The Sustained Oscillations On The Center Disc Was 2.9 to 3.4 Times The Maximum Peak-To-Peak Oscillations Found On The Center Discs
- The Duration Of The Oscillations On The Outer Discs Was The Same As That On The Center Discs
- The Oscillations Were Out Of Phase By 12 Degrees Which Corresponds To The 12 Degrees Offset Of The Instrumented Spokes On The Outer And Center Discs

Sustained Oscillations On The Outer Discs

Geographic Location	File	Time Span in the File (Secs)	Time Duration In Secs	Max Pk-to-Pk	Ratio of Center to Outer Disc Peak-to-peak
1685 SW of MP E17	File17	218 to 246	28	587	2.90
190 SW of MP AN13	File19	142 to 164	22	498	2.86
516 SW of MP AP25	File20	1251 to 1257	6	385	3.23
2303 NE of MP AP65	File21	1204 to 1224	20	508	2.76
947 NE of MP AP71	File21	1475 to 1507	32	452	2.62
1573 W of MP AP91	File21	2392 to 2404	12	299	3.36
471 SW of MP AP79 Gunpow	File21	2019 to 2022	3	391	2.95

Influence Of Brake Cylinder Pressure On Sustained Oscillations

- Based On The Tables
- Cross Plot–Maximum Strained BOP (Peak-to-Peak) Versus Brake Cylinder Pressure

Sustained Oscillations

Peak BOP Strain Versus Brake Cylinder Pressure

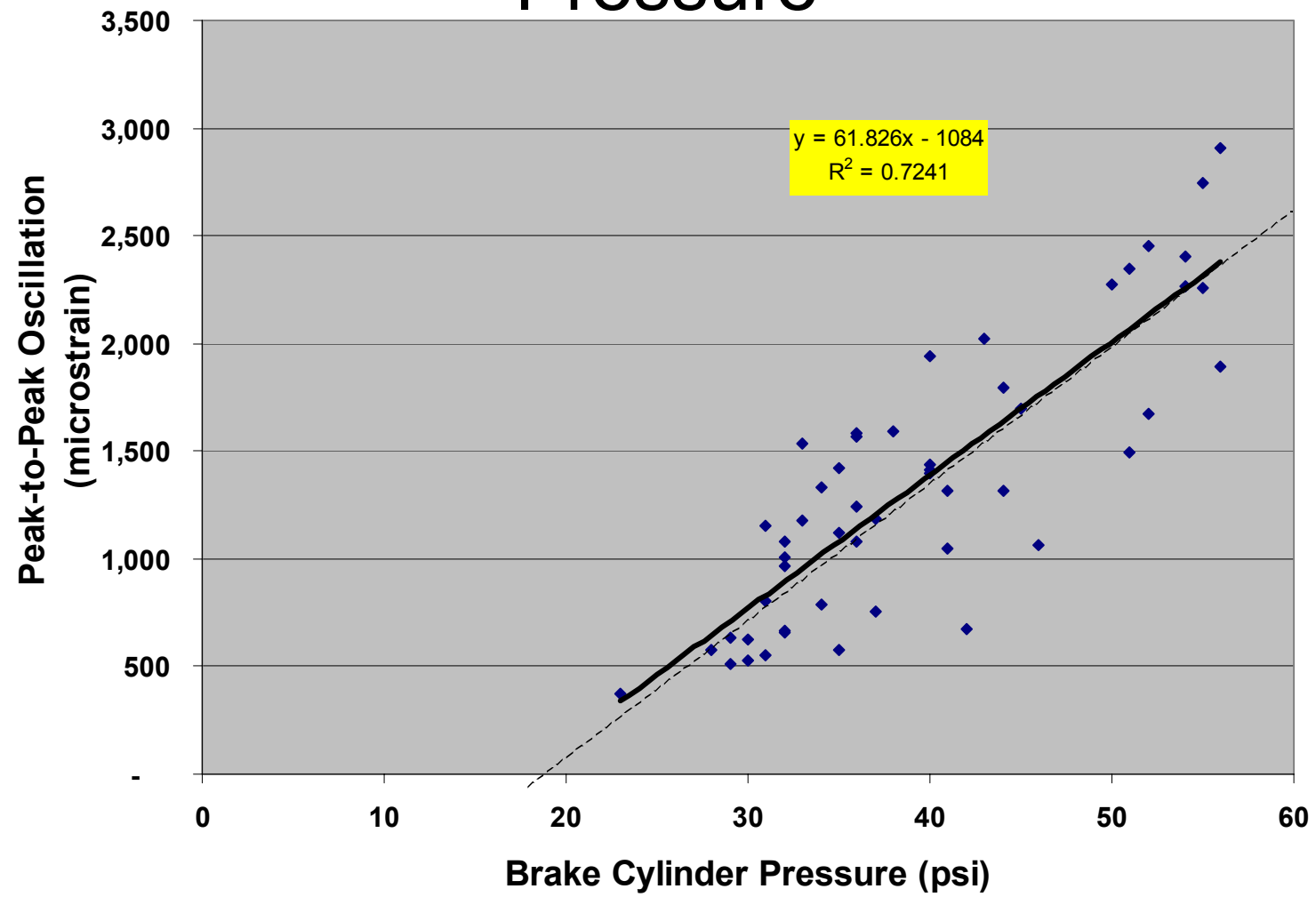

Sustained Oscillations

Peak BOP Strain Versus Brake Cylinder Pressure

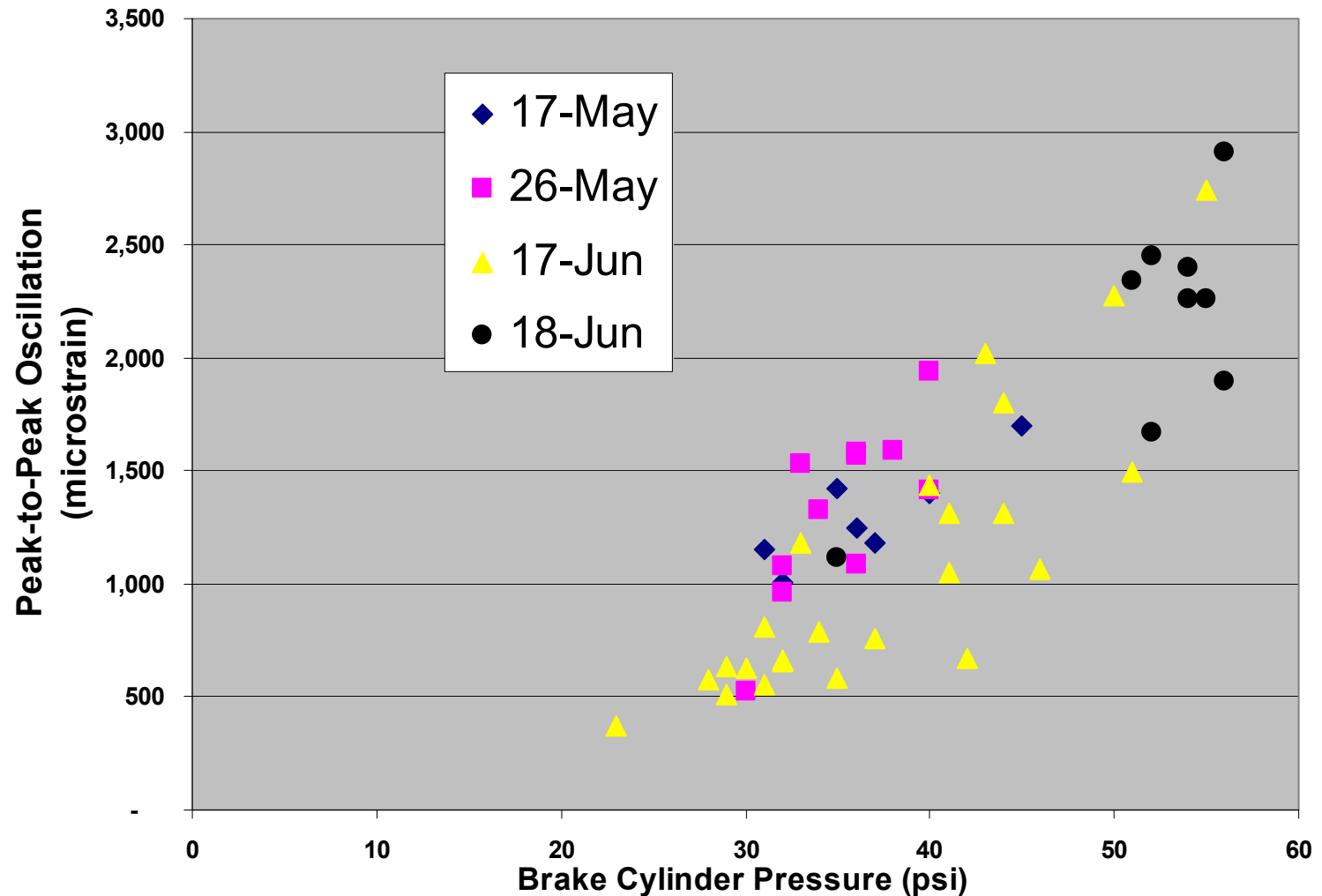

Sustained BOP Oscillations In Braking

- 51 Occurrences Of Sustained BOP Oscillations
- Total Duration—774 Seconds
- Only When The Instrumented Axle Was In The Lead

Day 7-File 03

Center Rotor Spoke 6 R1, blue = WABTEC/SAB-WABCO Disc, green = Knorr Disc

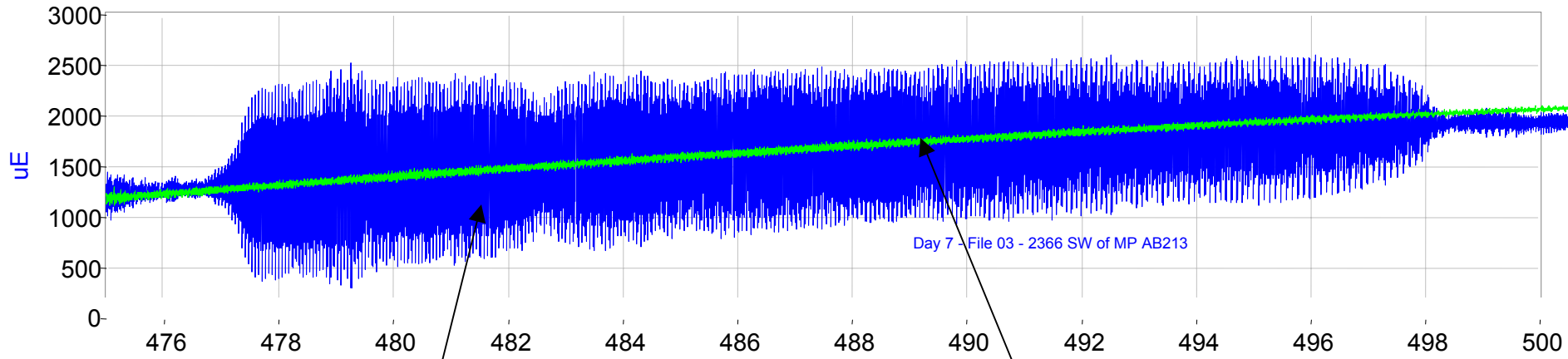

WABTEC/SAB-WABCO Disc

Knorr Disc

PSD of Center Rotor Spoke 6 R1 Strain, 16384 points, 5 point moving avg

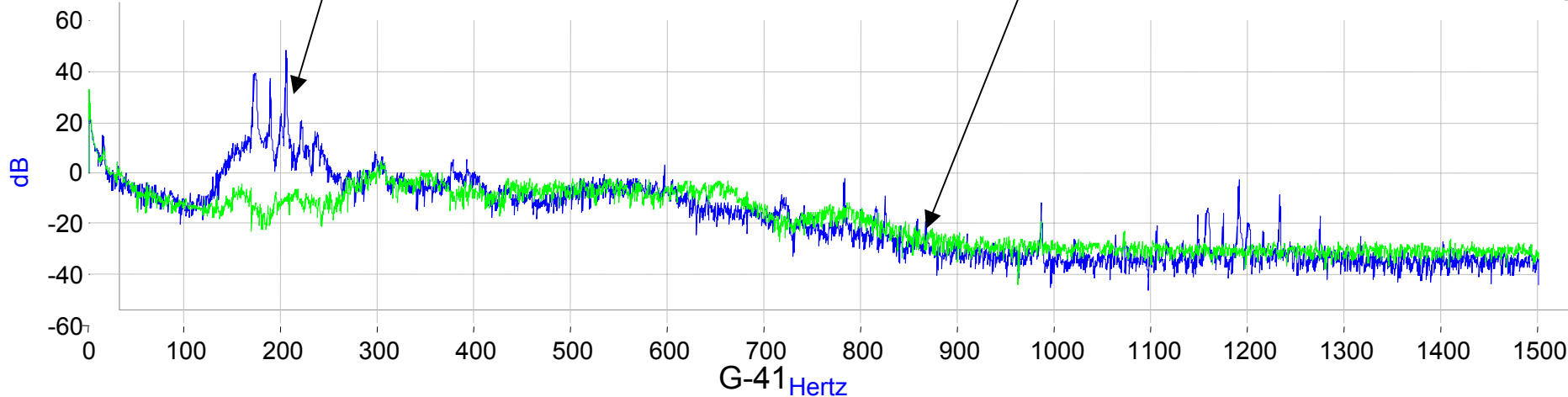

Relationship Of BOP Strain To Acceleration Difference

Relationship Of BOP Strain To Acceleration Difference

- Acceleration Difference Is Related To The BOP Strain Observed During Testing
- For A Single Acceleration Difference Peak, the BOP Strain is $\sim 7.5 \mu\epsilon/G$
- Sometimes The Acceleration Difference Has Multiple Large Peaks Within A Half Wheel Revolution
- Bombardier Requested That Two Specific Events Be Reviewed

Two Cases

- Case 1
 - May 27 (File 1 @ ~372 seconds)
 - Peak Acceleration Difference—102 g's
 - BOP Magnitude Response—~2,200 $\mu\epsilon$
 - Minimum BOP Strain -2258 $\mu\epsilon$
 - Maximum BOP Strain +2051 $\mu\epsilon$
- Case 2
 - June 17 (File 24 @ ~85 seconds)
 - Peak Acceleration Difference—189 g's
 - BOP Magnitude Response—~1,000 $\mu\epsilon$
 - Minimum BOP Strain -1033 $\mu\epsilon$
 - Maximum BOP Strain +889 $\mu\epsilon$

Case 1 Right And Left Acceleration

Vertical Acceleration, May 27, File 01

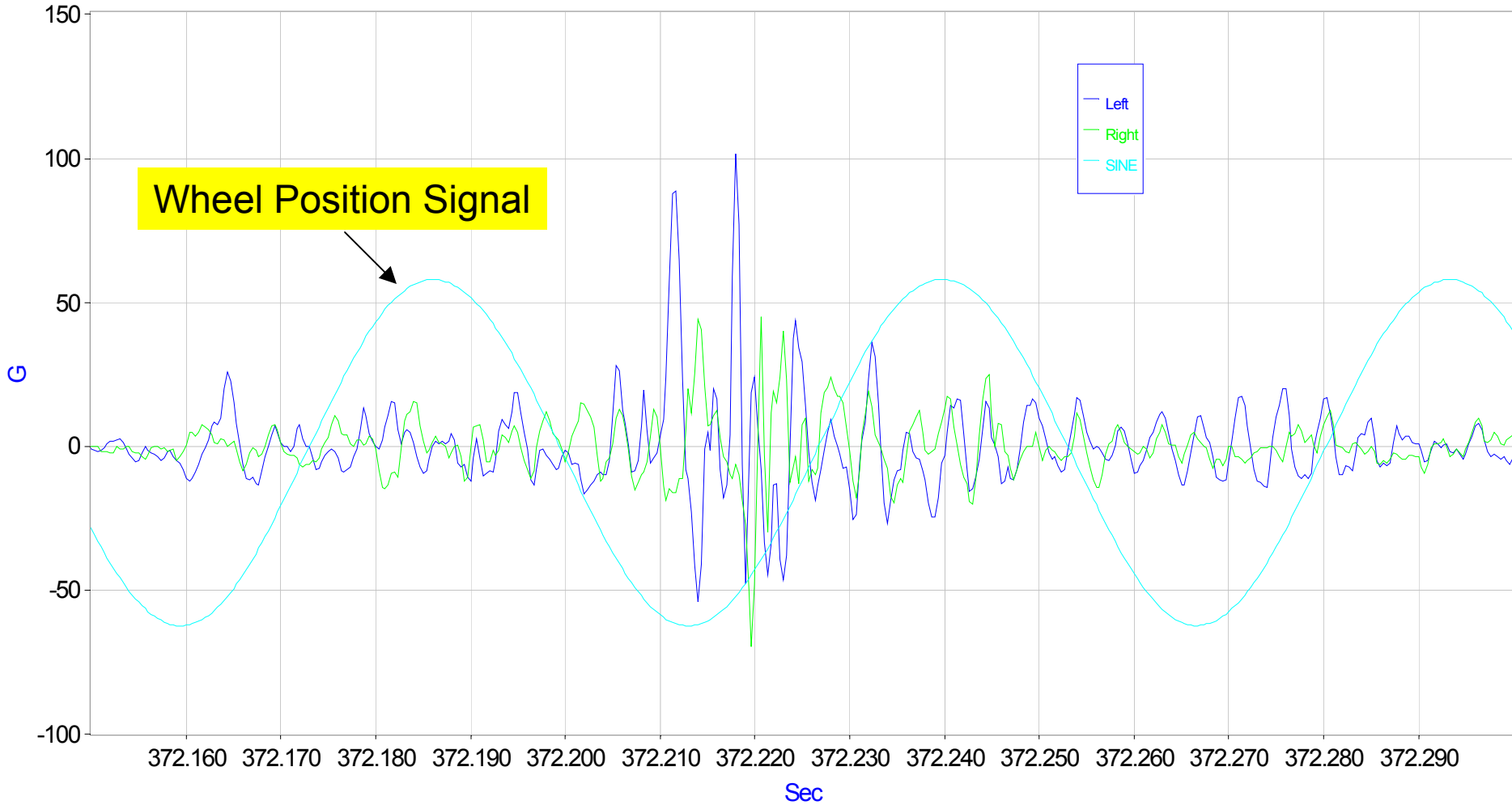

Case 1 Lateral Acceleration

Lateral Acceleration, May 27, File 01

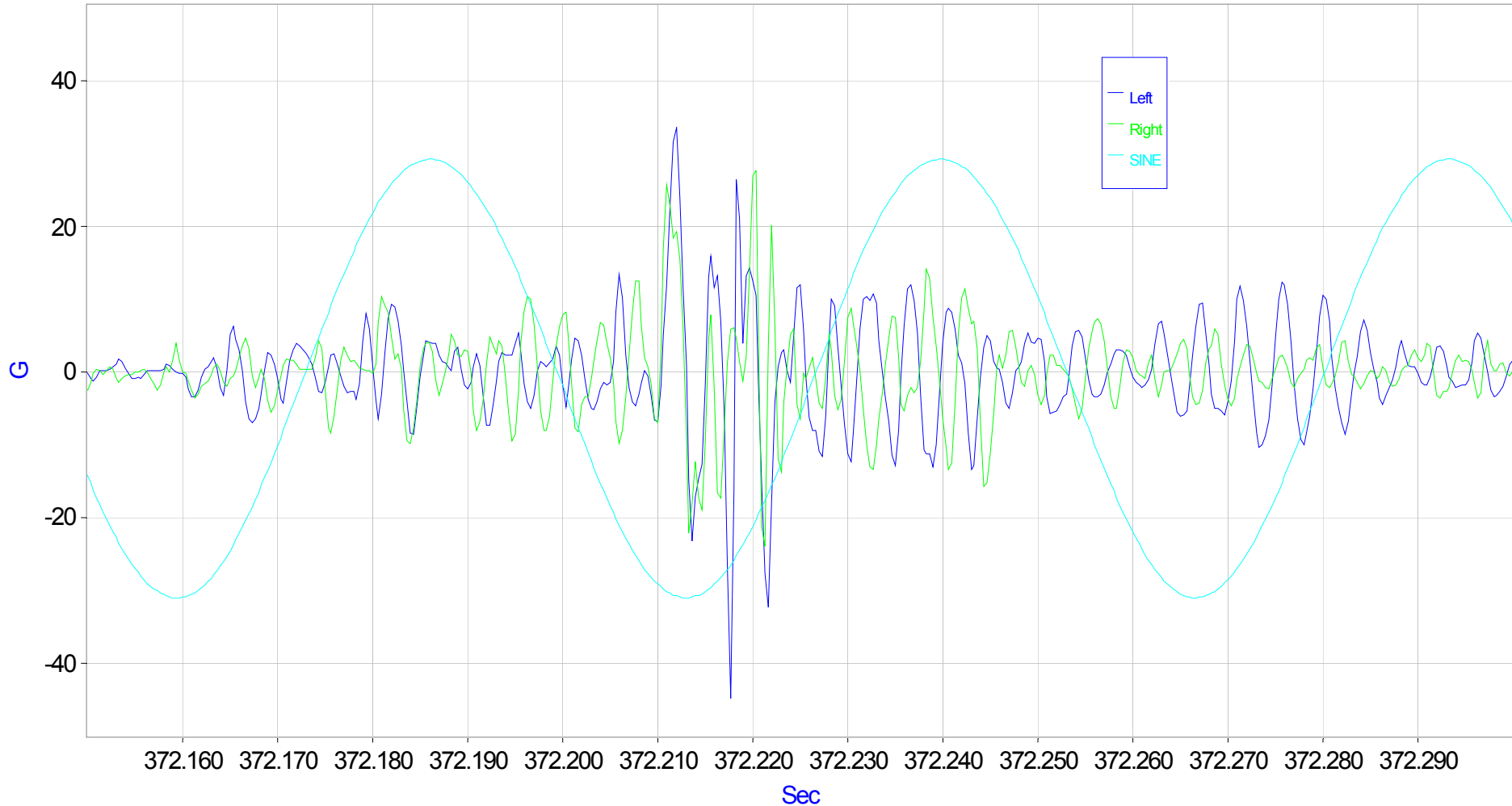

Case 1 May 27

Input Acceleration Difference (Left-Right)

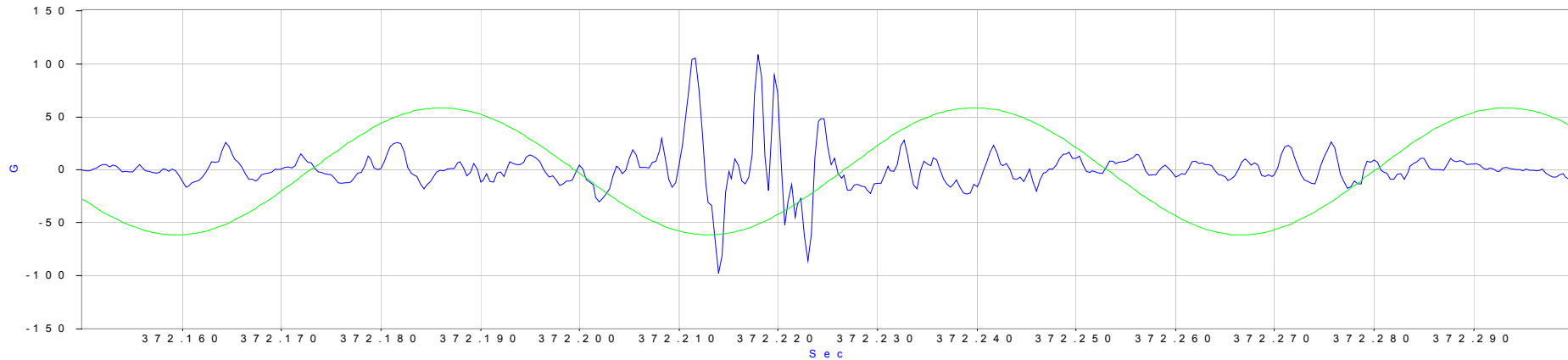

Output BOP Strain

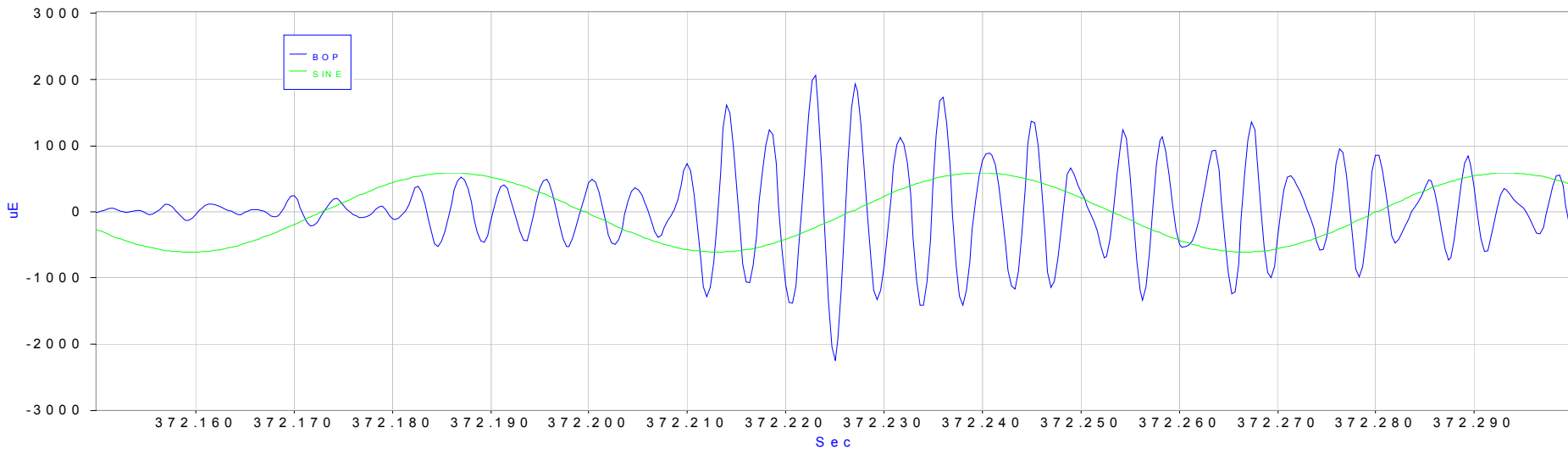

Case 2 Right And Left Acceleration

Vertical Acceleration, June 17, File 24

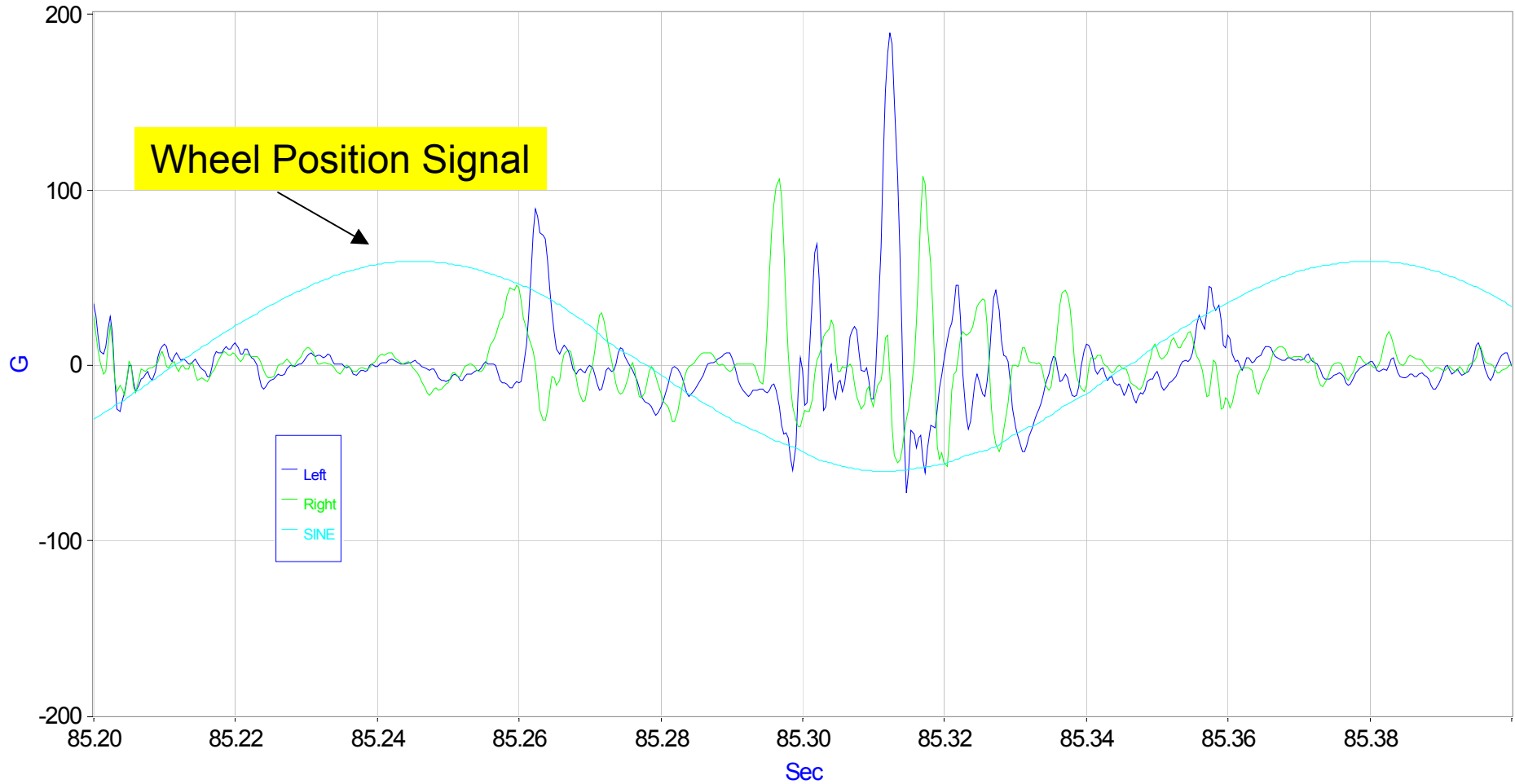

Case 2 Lateral Acceleration

Lateral Acceleration, June 17, File 24

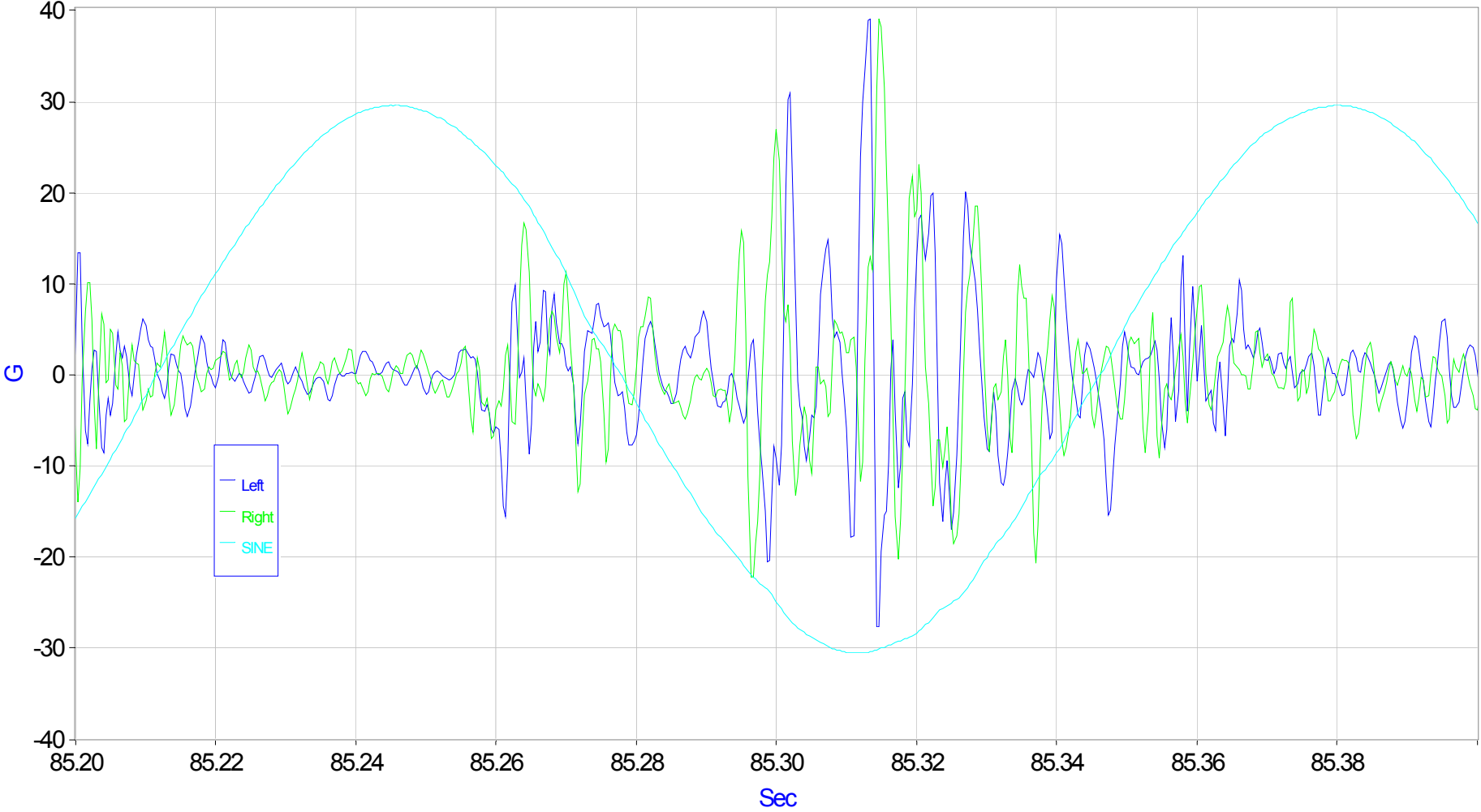

Case 2 June 17

Input Acceleration Difference (Left-Right)

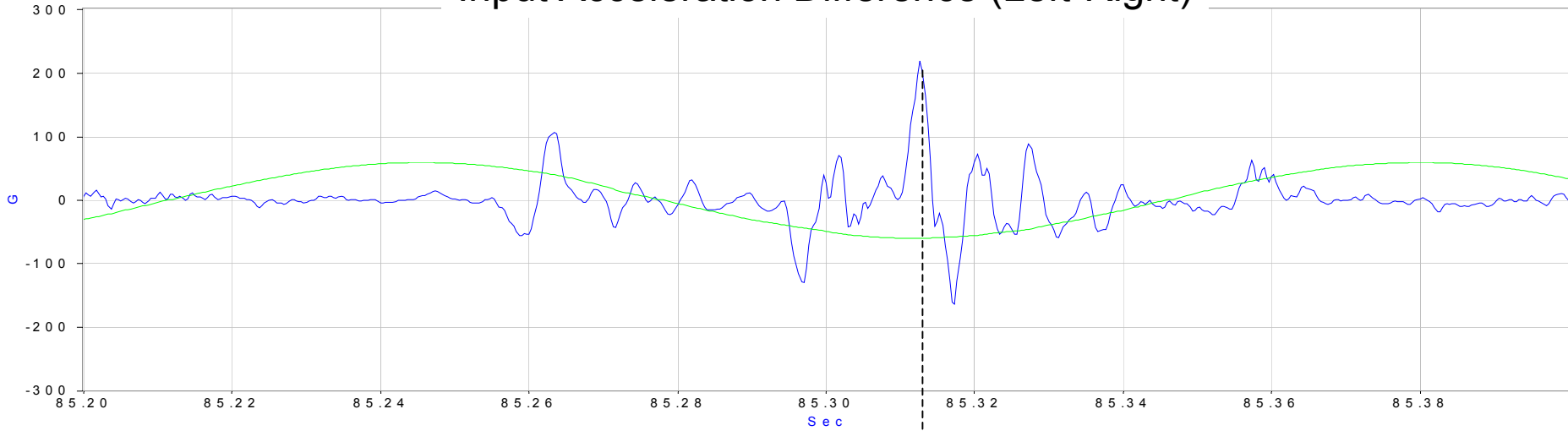

Output BOP Strain

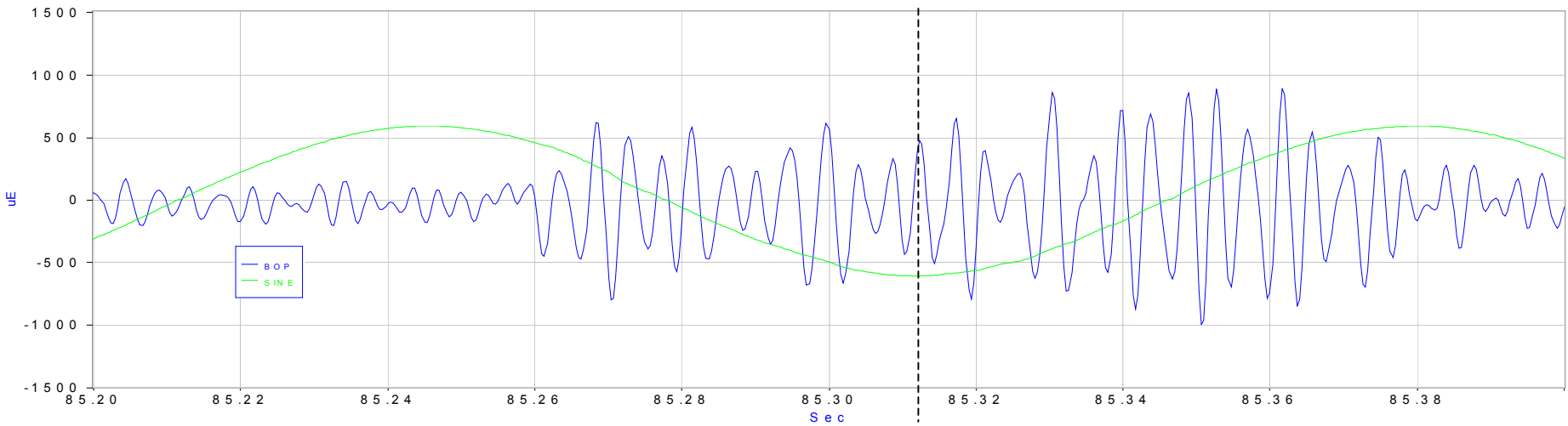

G-50

PSD Of BOP Strain, Case 1

PSD of Bending Out-of-Plane, May 27, File 01

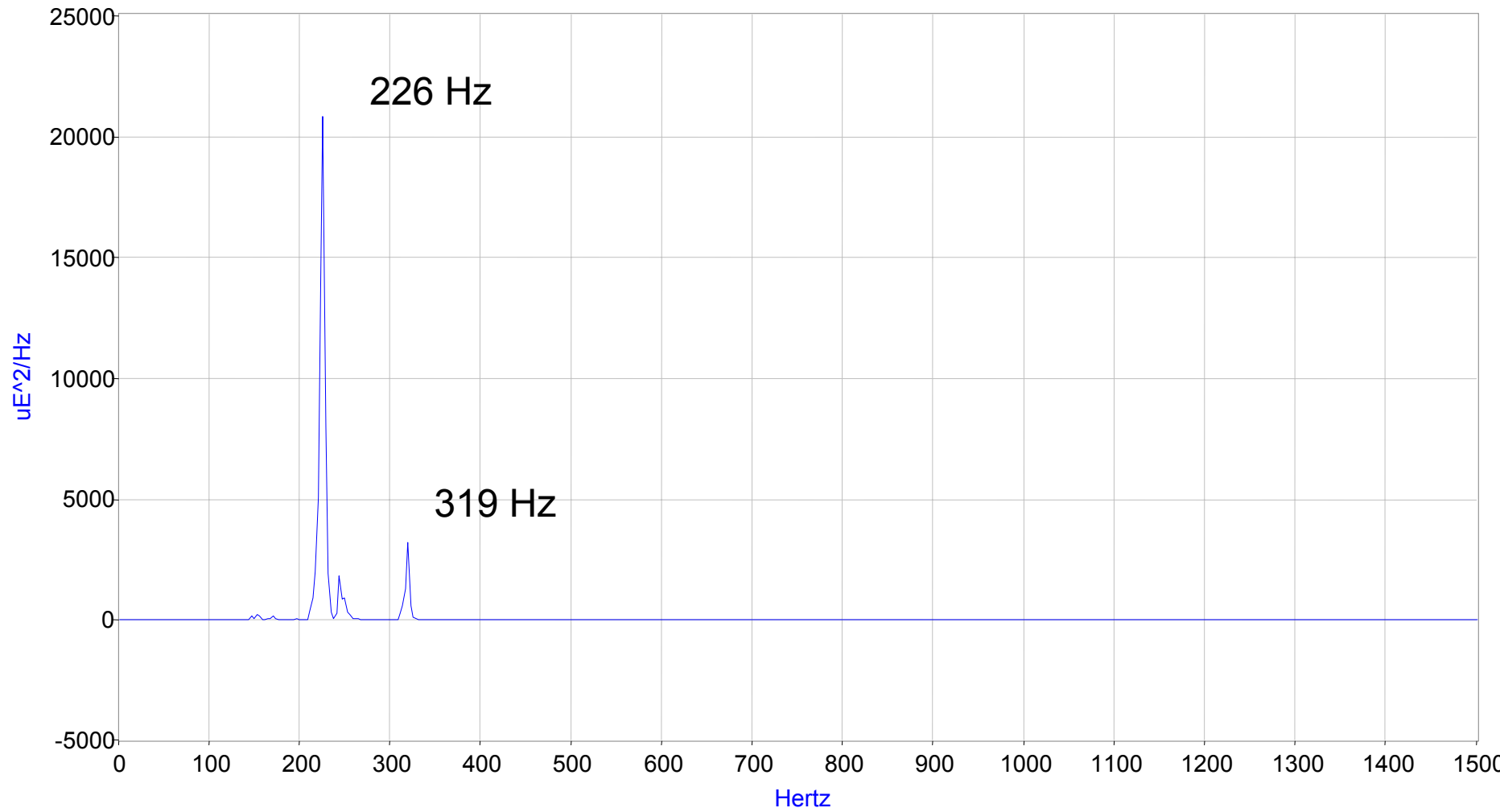

PSD Of BOP Strain, Case 2

PSD of Bending Out-of-Plane, June 17, File 24

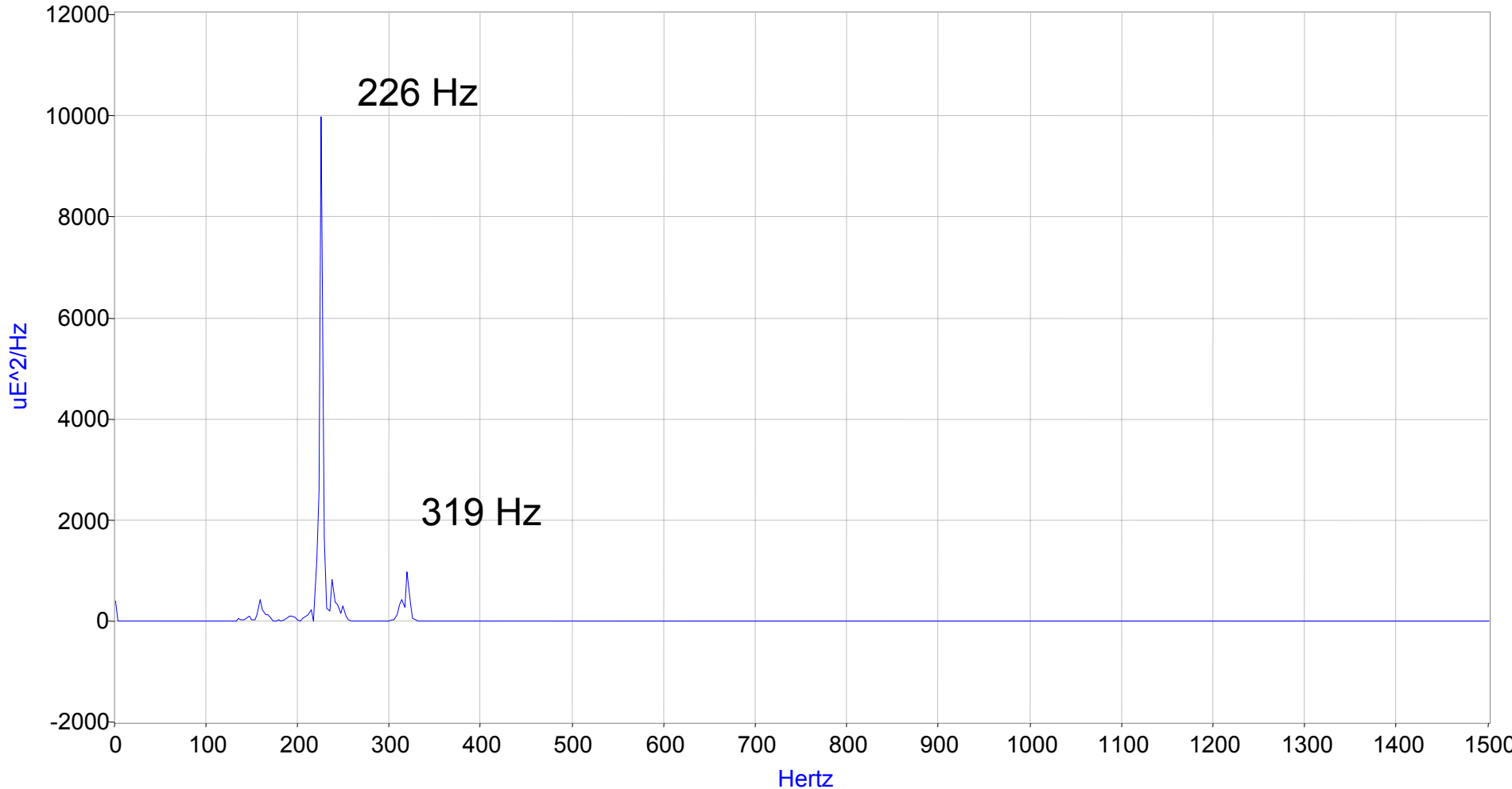

Observations

- The Largest Peak In The Spectrum Of The BOP Strain Is Observed At 227 Hz
- The Second Largest Peak In The Spectrum Of The BOP Strain Is Observed At 319 Hz
- The PSD Level Of The Largest Peak At 227 Hz Is 10 Times The Level Of The Second Largest Peak At 319 Hz

Theory

- A Possible Cause For BOP Strains Not Being Proportional To Large Peak Acceleration Differences Is That The Results Of Two Accelerations Peaks Do Not Add Arithmetically But Add Vectorially
- This Allows For Both Constructive And Destructive Interference In BOP Strain Response
- The Following Slides Provide A Conceptual Description Of This Effect

Terminology

- Interference Constructively
 - When superposition leads to a maximum possible intensity
- Interference Destructively
 - When superposition leads to zero intensity
- Interference
 - Between the limits of interference constructively and interference destructively

Reference: *The Physics of Vibrations and Waves*,
H.J. Pain

Theory

BOP Strain versus Time

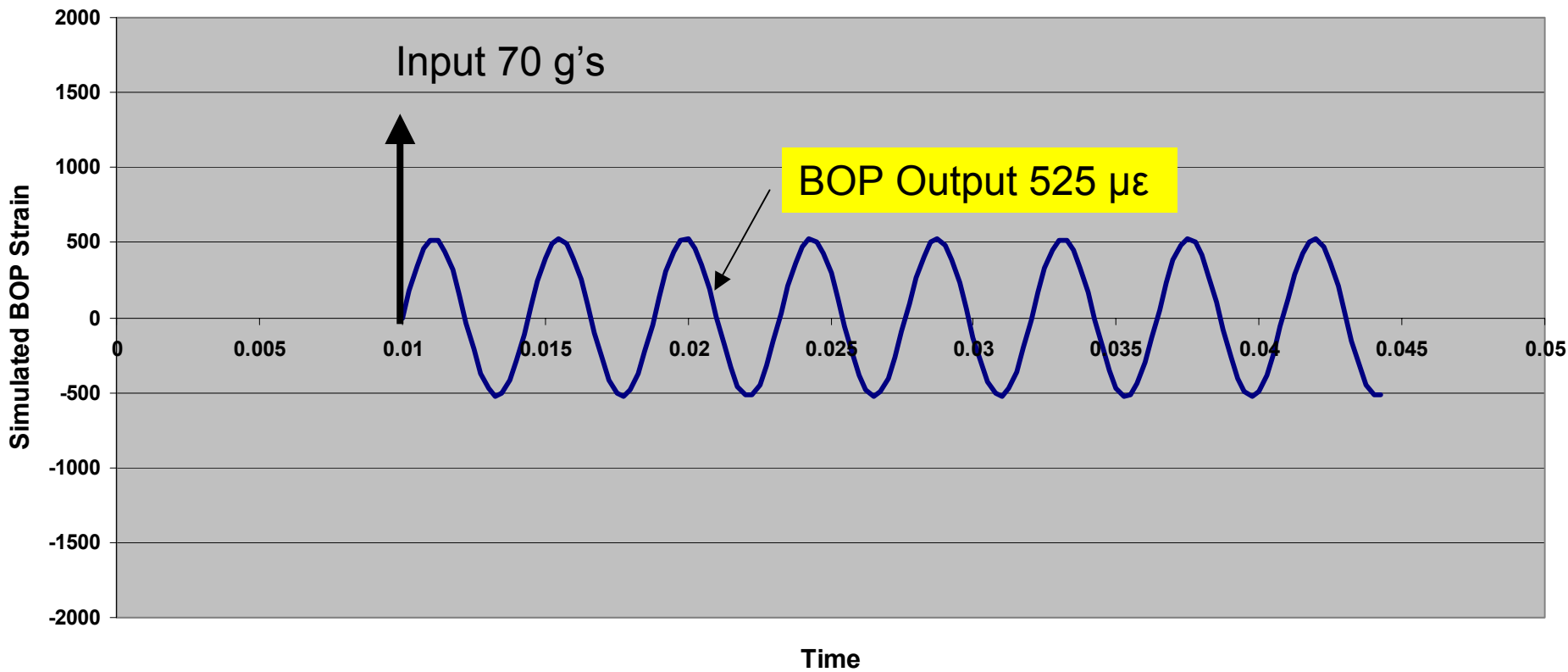

Two Inputs

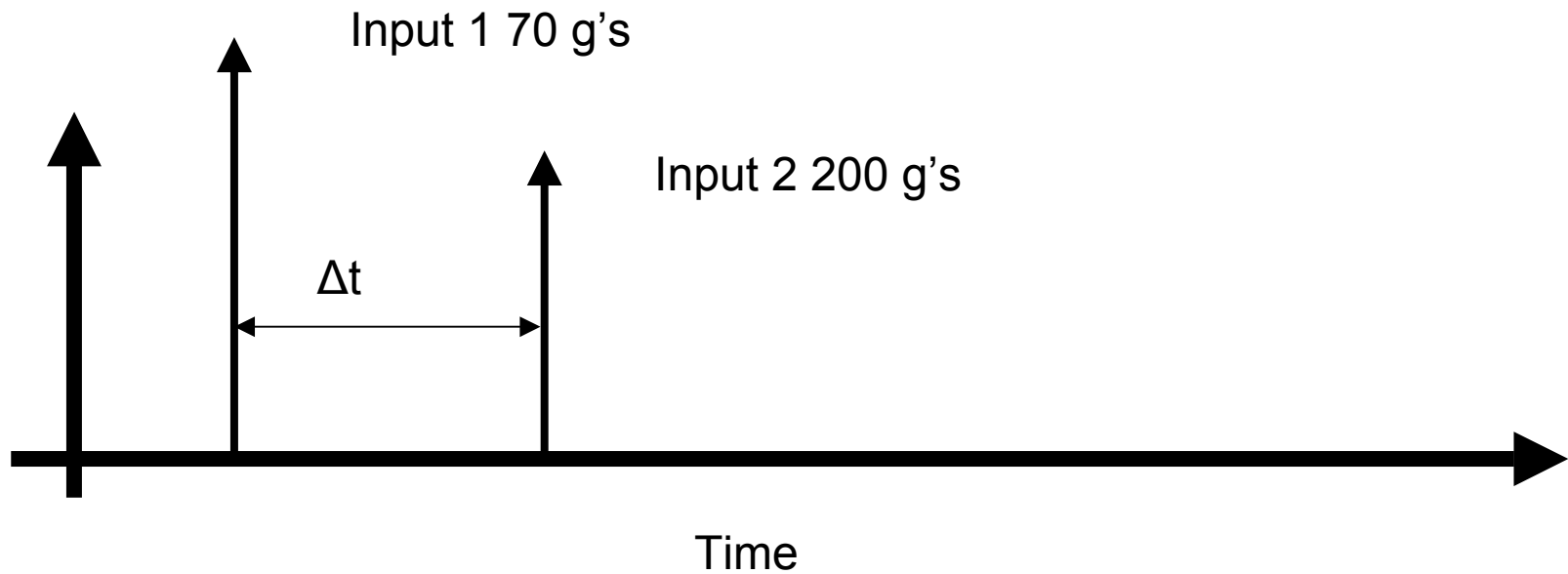

Example 1

BOP Strain versus Time
Delta T = 0.01125 seconds

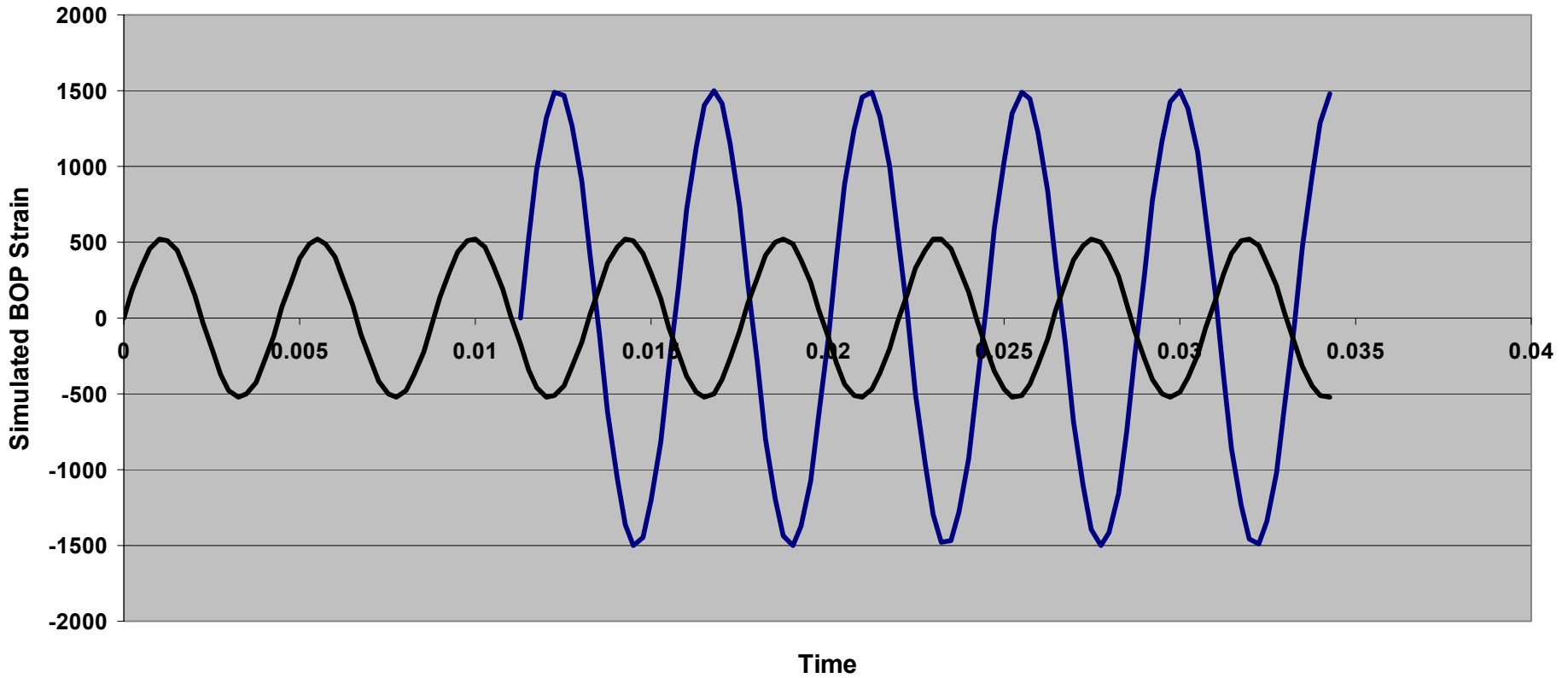

Example 1 Combined BOP Strain From The Two Inputs

Partial Destructive Interference

BOP Strain versus Time

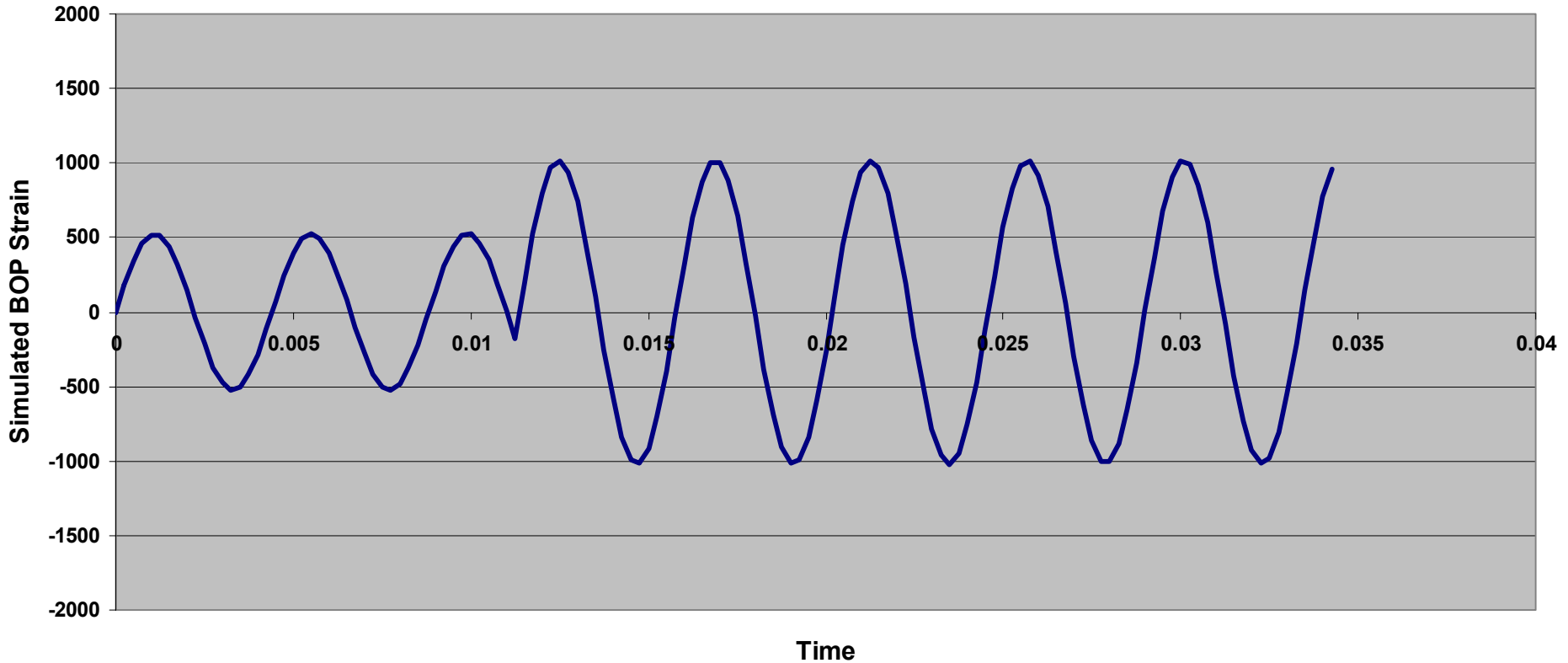

Example 2

BOP Strain versus Time
Delta T = 0.009 seconds

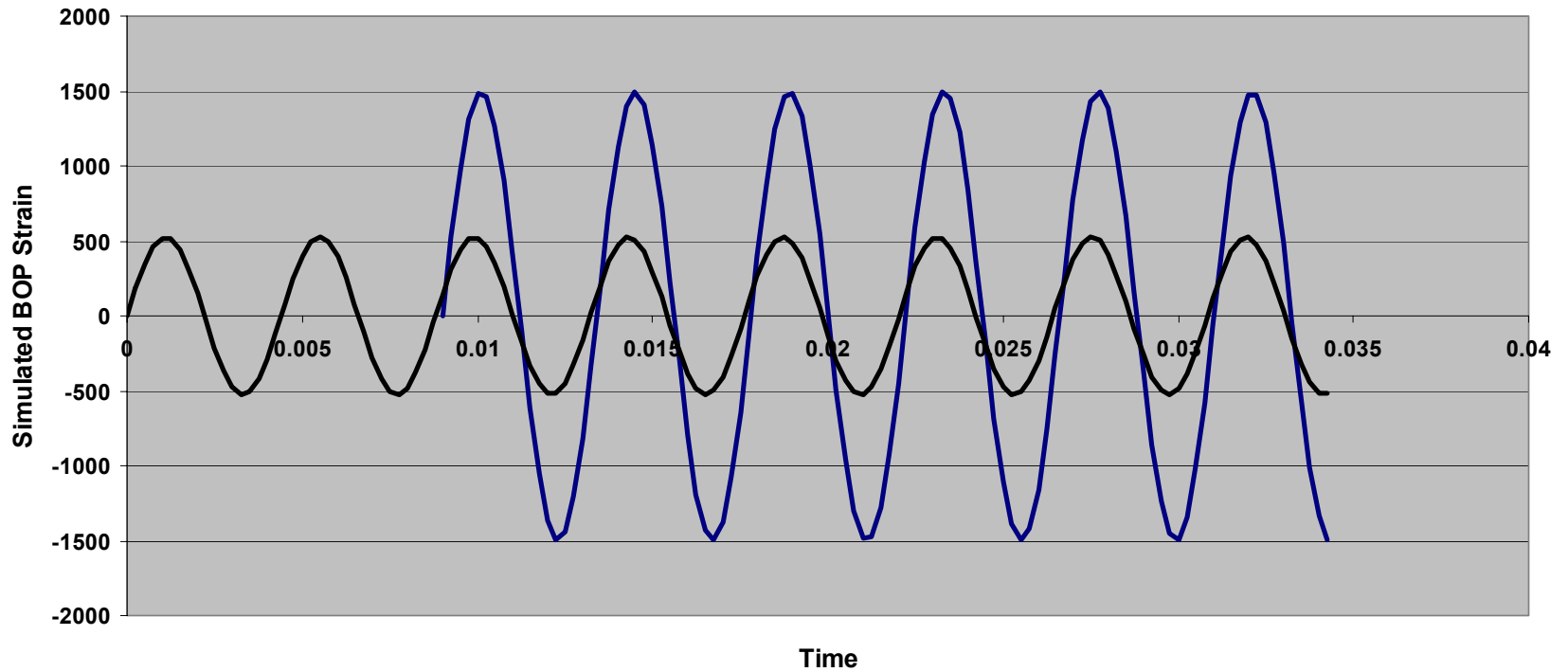

Example 2 Combined BOP Strain From The Two Inputs

Partial Constructive Interference

BOP Strain versus Time

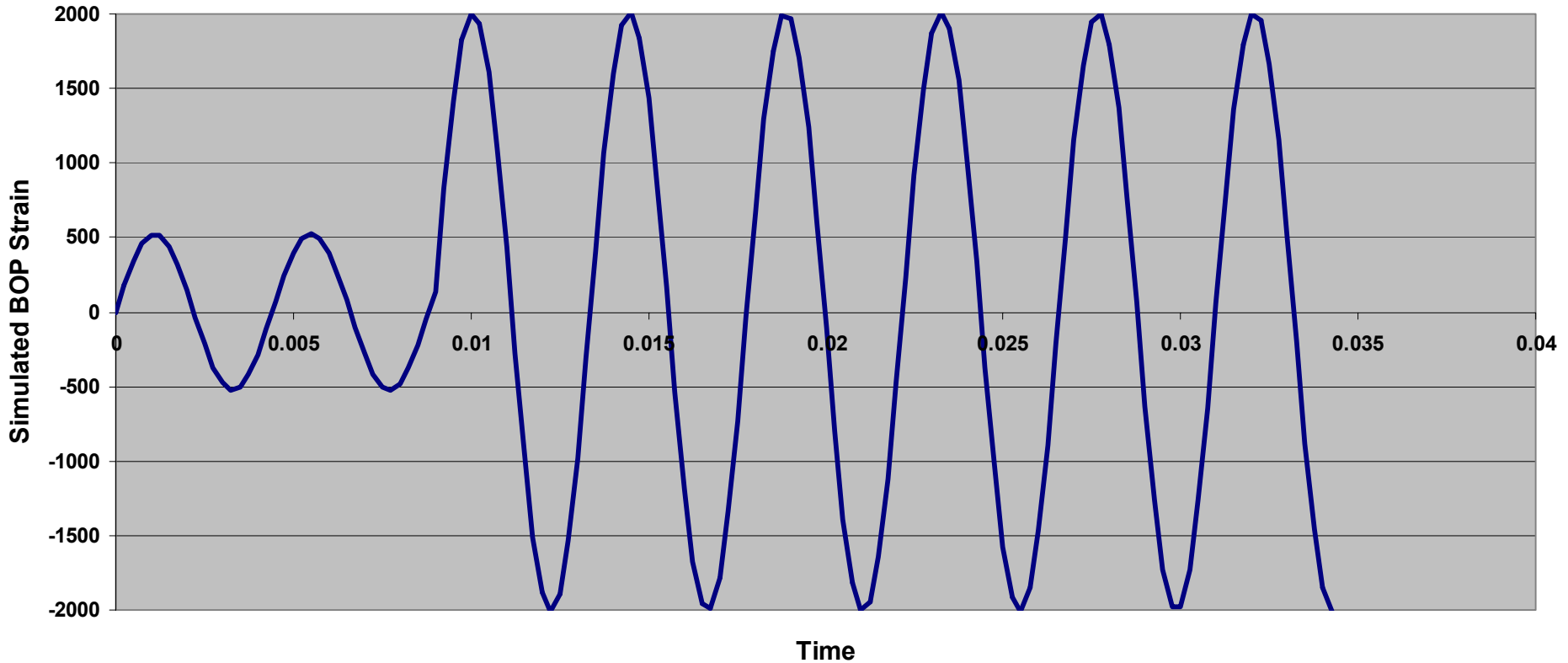

Estimate Of Fatigue Effects And Goodman Plots

Fatigue

- Process In Which Damage Accumulates Due To The Repetitive Application Of Loads
- Strains Due To These Loads Are Well Below The Yield Strain Of The Material
- Fatigue Consists Of:
 - Crack Initiation
 - Crack Propagation
 - Final Fracture
- Spoke Cracks In WABTEC/SAB-WABCO Disc May Be Influenced By Fatigue

ASTM Definition

- Fatigue Life Is The Number Of Cycles Of Stress Or Strain Of A Specific Character That A Given Specimen Sustains Before Failure Of A Specific Nature Occurs
- Fatigue Strength Is The Hypothetical Value Of Stress At Failure For Exacting N Cycles
- Fatigue Limit, S_f , Is The Limiting Value Of Median Fatigue Strength As N Becomes Very Large

SN Curve

S-N Diagram

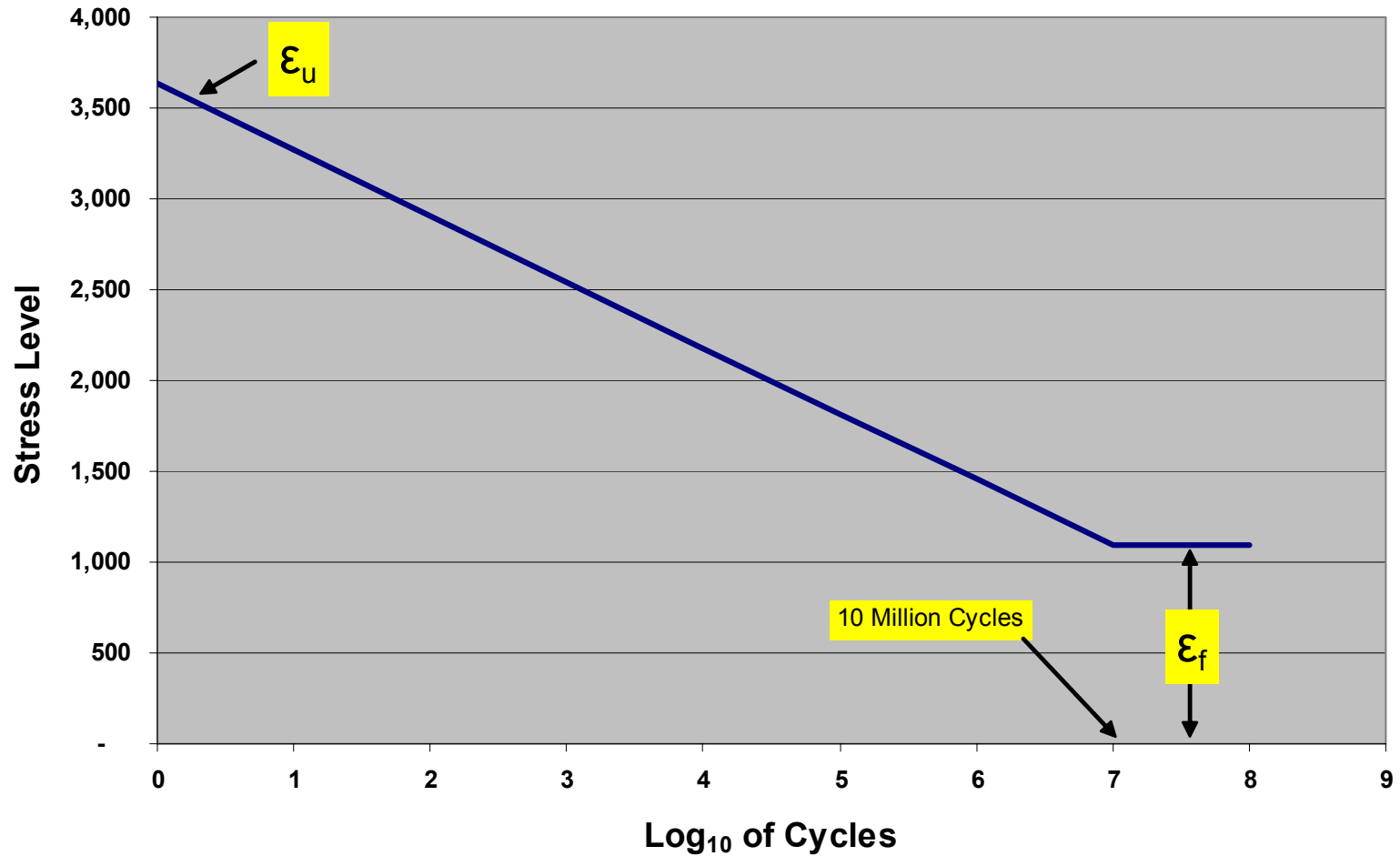

G-65

**Table G.7. Key Stress/Strain Values for
WABTEC/SAB-WABCO Disc**

WABTEC/SAB-WABCO Disc					
Value	Stress (Mpa)	Stress (psi)	Compared to Ultimate	Micro- Strain	Source
Young's Modulus	210,345	30,500,000			Steel
Ultimate Strength	752	109,000	100%	3,574	SHTL
Yield Strength	550	79,750	73%	2,615	SHTL
Endurance Limit	226	32,700	30%	1,072	30% Ultimate
Pre-Strain (Press On)	84	12,200	11%	400	see Appendix H
Pre-Strain (As Built)	126	18,300	17%	600	see Appendix H
Pre-Strain (Total New)	210	30,500	28%	1,000	see Appendix H
True Fracture Stress <small>(European)</small>	1,232	178,689	164%	5,859	SHTL
True Fracture Stress <small>(USA)</small>	1,059	153,521	141%	5,033	SHTL

SHTL– Stork Herron Testing Laboratories

Table G.8. Key Stress/Strain Values for Knorr Disc

Value	Stress (MPa)	Stress (PSI)	Comparison to "Ultimate"	Micro-Strain	Source
Young's Modulus	210,000	30,450,000	-	-	SWL
Ultimate Strength	1,050	152,250	100%	5,000	N10193
Yield Strength	900	130,500	86%	4,286	N10193
Endurance Limit	300	43,500	29%	1,429	SWL
Pre-Strain (Press On)	112	16,230	11%	533	see Appendix J

Provided by Knorr-Bremse

Typical Data

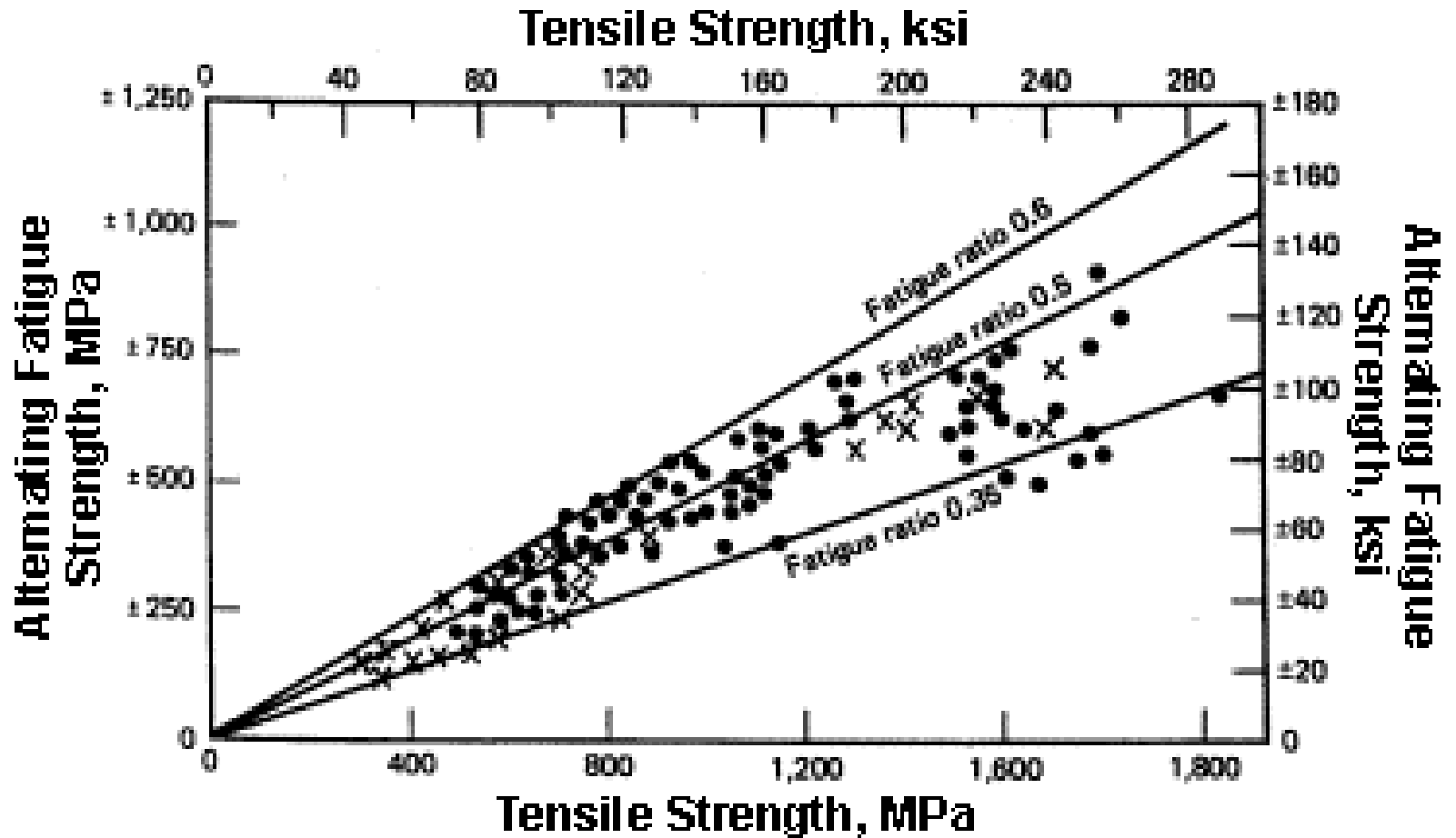

<http://www.fatiguecalculator.com/>

Other Factors May Lower Fatigue Ratio

- Environment
 - Water
 - Sea Water
- Corrosion Fatigue Effects
- Casting Irregularities

Environment

Metal Fatigue in Engineering
H.O. Fuchs and R.I. Stephens

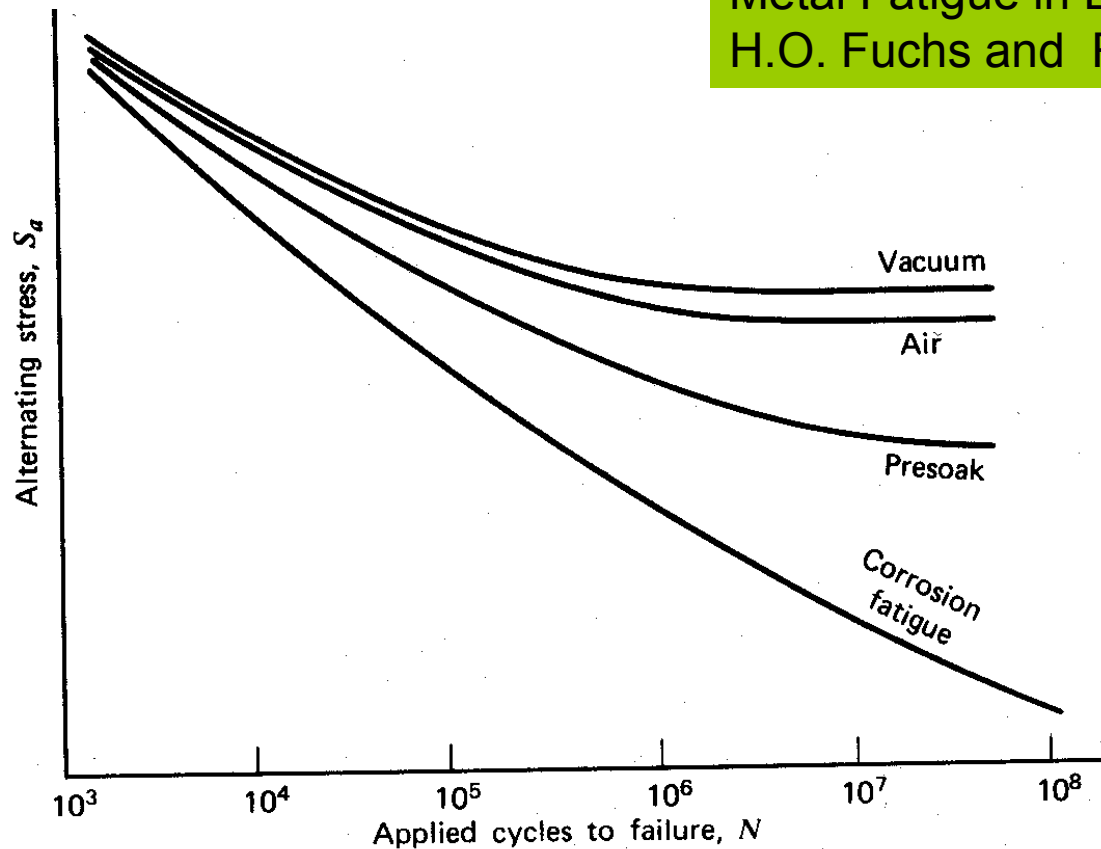

FIGURE 11.3 Relative fatigue behavior under various environmental conditions.

Combined Stress

- Load Conditions
 - S_a = Alternating Strain (Zero-To-Peak)
 - S_m = Mean Strain
- Material Properties
 - S_u = Ultimate Strain
 - S_y = Ultimate Strain
 - S_f = Ultimate Strain
- Mean Stress Has A Substantial Influence On Fatigue Behavior

Mean Strain/Alternating Strain Models

- Modified Goodman $\frac{S_a}{S_f} + \frac{S_m}{S_u} = 1$

- Gerber $\frac{S_a}{S_f} + \left(\frac{S_m}{S_u}\right)^2 = 1$

- Soderberg $\frac{S_a}{S_f} + \frac{S_m}{S_y} = 1$

Combined And Alternating Strain

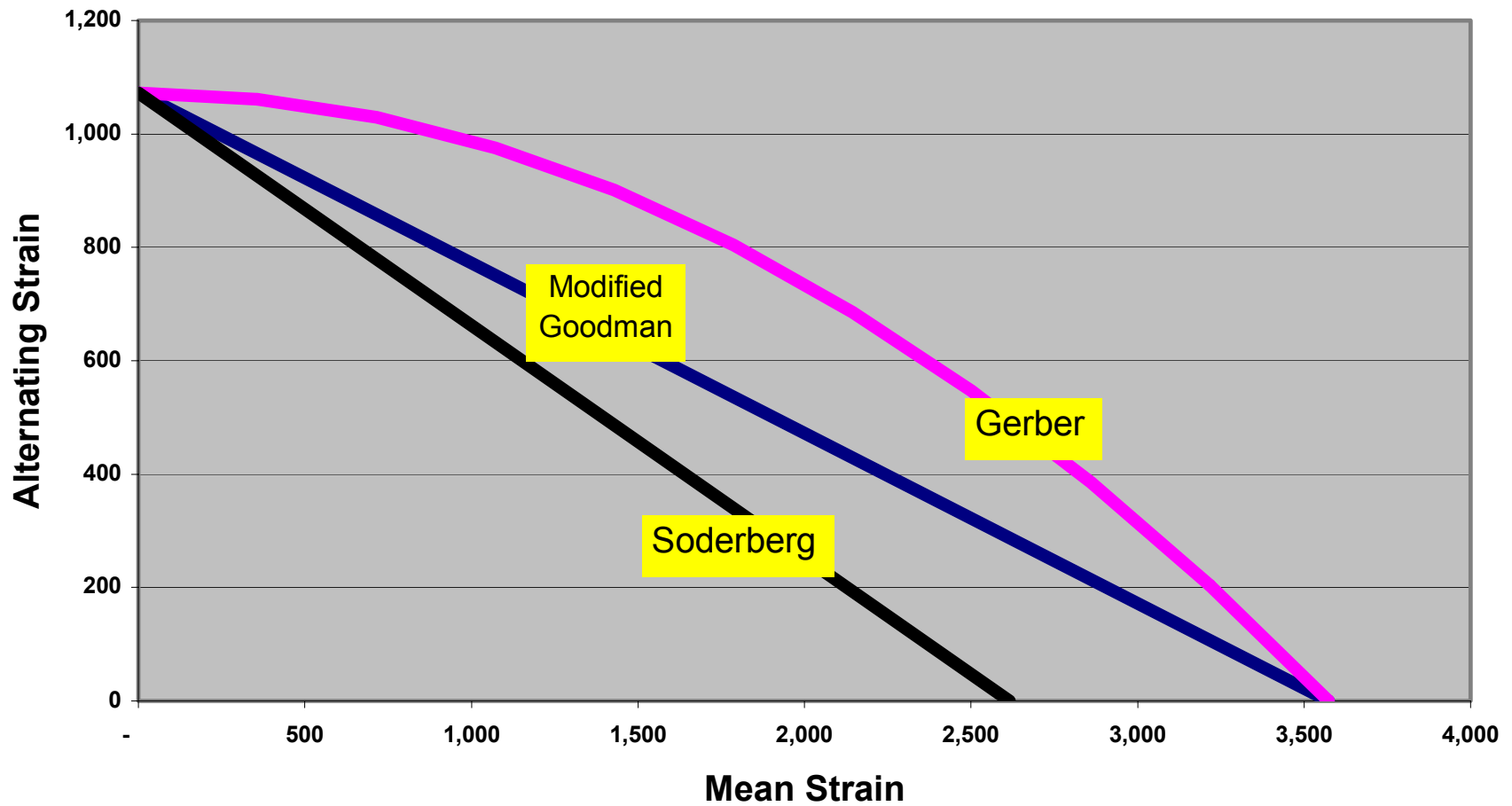

G-73

Strain In Spoke

- Pre-Stress (Strain) Due To Manufacturing
- Pre-Stress (Strain) Due To Hub Interference Fit
- Tensile Strain Due To Friction Ring Expansion
- Bending Out-Of-Plane Strain

Compressive Pre-Strain Concept

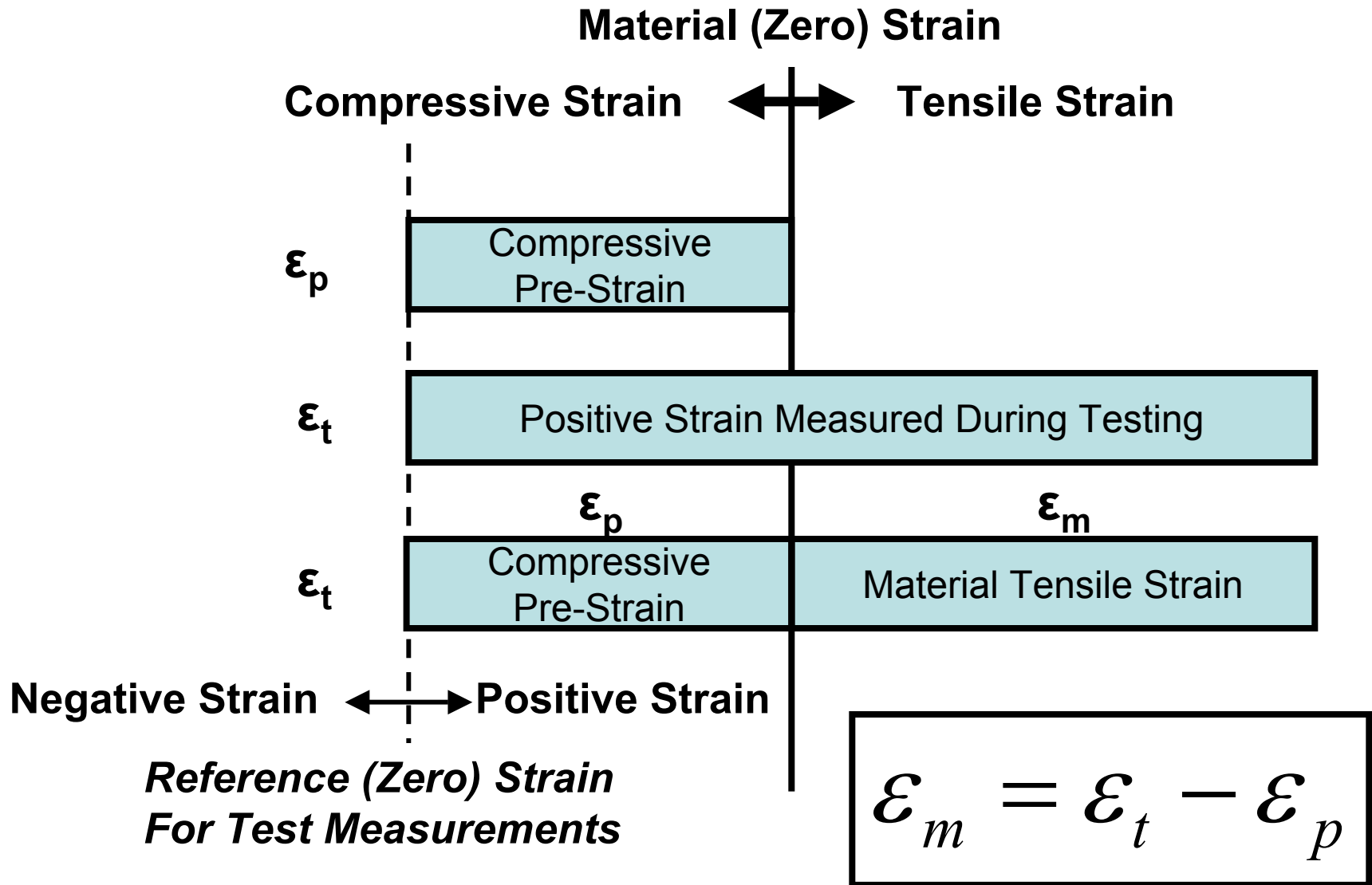

Mean And Alternating Strain

- A Fatigue Prospective Of The Test Data Requires Simultaneous Tabulation Of Mean Strain (Thermal Effect) And Alternating Strain (BOP)
- A Modified Goodman Line Based On Fatigue Limit Of 30% Ultimate Strain Was Used For This Exercise
- This Is Not Intended As A Fatigue Analysis When K Factors Would Be Required But An Exercise To Determine Where In The Data Significant Combinations Of Mean And Alternating Strains Occur
- The Mean (Tensile Strain) Must Account For The Pre-Strain In The Spokes
- Based On Test Of Disc During Press-On Operations And Cutting Of Spokes On Disc Removed From Service, A Value Of 1,000 Microstrain Is Used For The Pre-Stress In The Spoke

Goodman Line in Terms of Stress For WABTEC/SAB-WABCO Disc Based on Material Properties

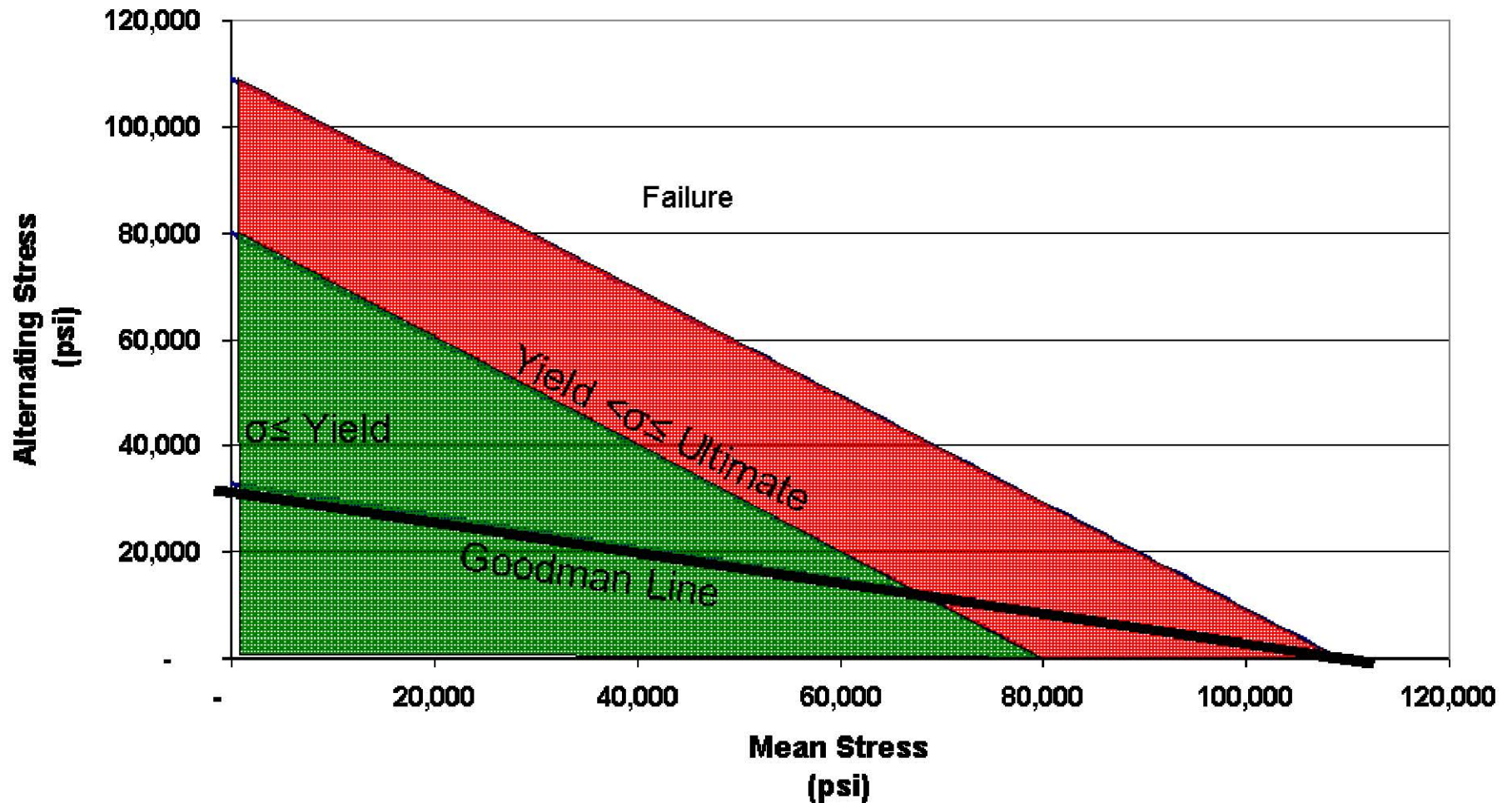

Transform The Goodman Plot From Stress To Strain

- Formulated Goodman Line In Terms Of Stress
- Transform To Strain By Dividing By Young's Modulus, E
- Indicated Where The Linear Stress-Strain Relationship Exists In The Mean Versus Alternating Plane; Denoted By Green On Plots
- Indicated Where The Non-Linear Relationship Exists In The Mean Versus Alternating Plane (In Excess Of Yield Stress, But Less Than Ultimate Stress); Denoted By Red On Plots

Goodman Line in Terms of Strain For WABTEC/SAB-WABCO Disc Based on Material Properties

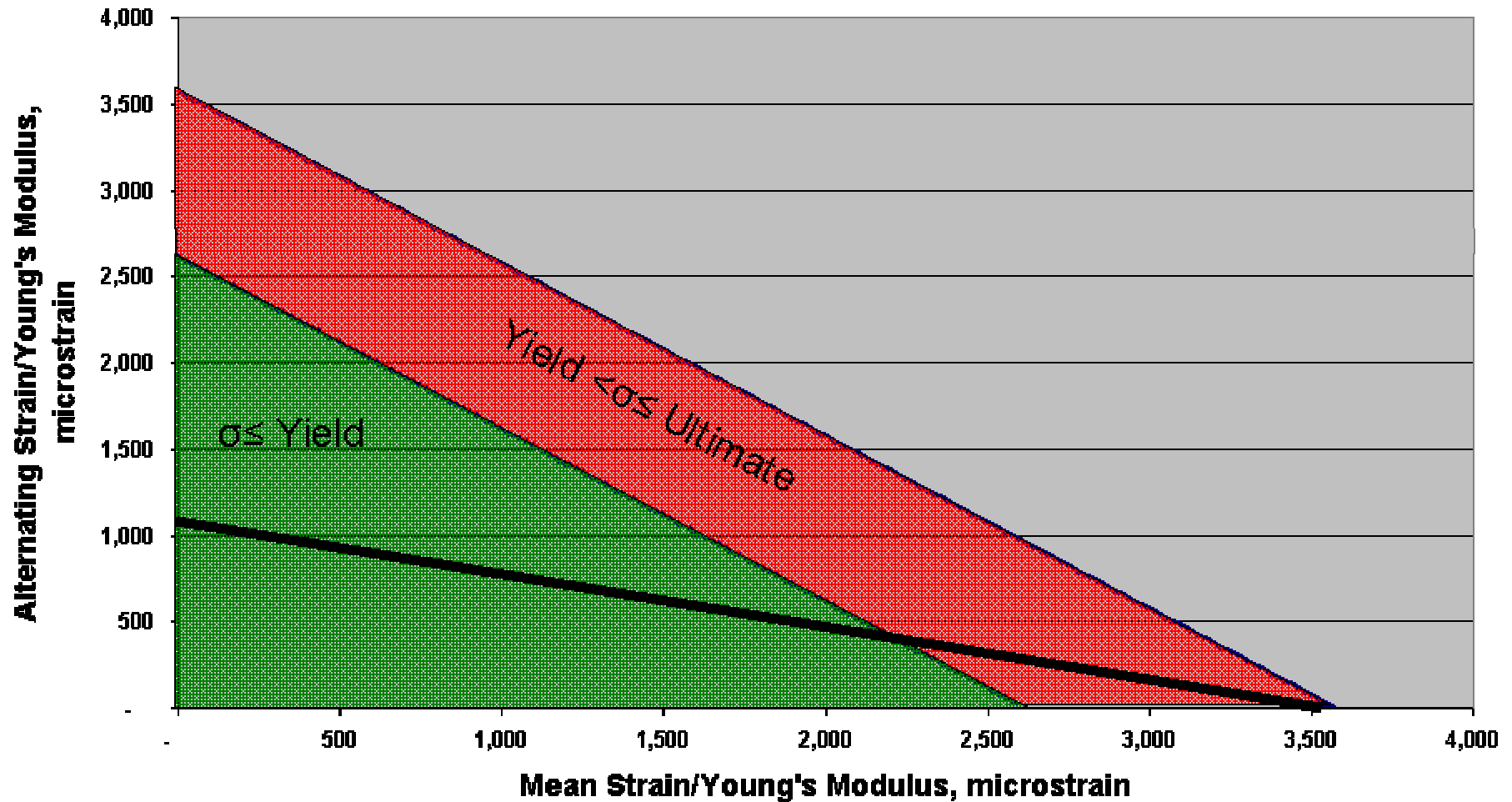

Checked on Test Data

- After The Data Was Processed, Checked That All Data Points Fell In The Green Zone (Area of Linear Stress-Strain Relationship)
- Only Cases That Approached Red Zone Were Those Where Vertical Impact Observed During Brake Application Where High Mean Strain Due To Heating Of Disc Observed

A Counting Method

- Calculate Mean Strain Minus 1000 Microstrain
- Calculate BOP Strain Required To Be Above Or Near Goodman Line
- Calculate BOP Strain
- Check If BOP Strain Is Near The Goodman Line
- If Yes, Calculate Cycles And Time Duration
- Record Mean Strain, Alternating Strain, Brake Pressure, Number Of Cycles, And Time Duration

Table G.9. Count of Cycles Near Limits

Goodman Plots Cycles

		WABTEC/SAB-WABCO Disc Axle 1								Knorr Disc Axle 2	
		Center Disc				Outer Disc				Center Disc	
		Spoke 3		Spoke 6		Spoke 3		Spoke 6		Spoke 6	
	Date	NB	B	NB	B	NB	B	NB	B	NB	B
Phase 1	16-May	n/a	n/a	4.5	0	n/a	n/a	5.5	0	n/a	n/a
	17-May	n/a	n/a	11.5	55	n/a	n/a	1	0	n/a	n/a
Phase 2	26-May	12	14	9	20	n/a	n/a	n/a	n/a	n/a	n/a
	27-May	6.5	0	10.5	0	n/a	n/a	n/a	n/a	n/a	n/a
Phase 3	17-Jun	2	2754	5	3156.5	n/a	n/a	n/a	n/a	0	0
	18-Jun	5	7074	6	6947	n/a	n/a	n/a	n/a	0	0

n/a Test Plan did not include this measurement

B Braking

NB Not Braking

Figures Included

- Phase 1
 - Center Disc Spoke 6
 - Outer Disc Spoke 6
- Phase 2
 - Center Disc Spoke 6
 - Outer Disc Spoke 6
 - Center Disc Spoke 3
 - Outer Disc Spoke 3
- Phase 3
 - Center Disc Spoke 6
 - Outer Disc Spoke 6
 - Center Disc Spoke 3
 - Outer Disc Spoke 3

Note:

- These figures are based on occurrences of combinations of BOP and mean strains that approach the Goodman line used in the analysis
- A single point in the figures may represent a single cycle or many cycles
- The above table shows the cumulative number of cycles

**Mean Strain Versus Alternating Strain, Center WABTEC/SAB-WABCO Disc,
Spoke 6–May 16, 2005**

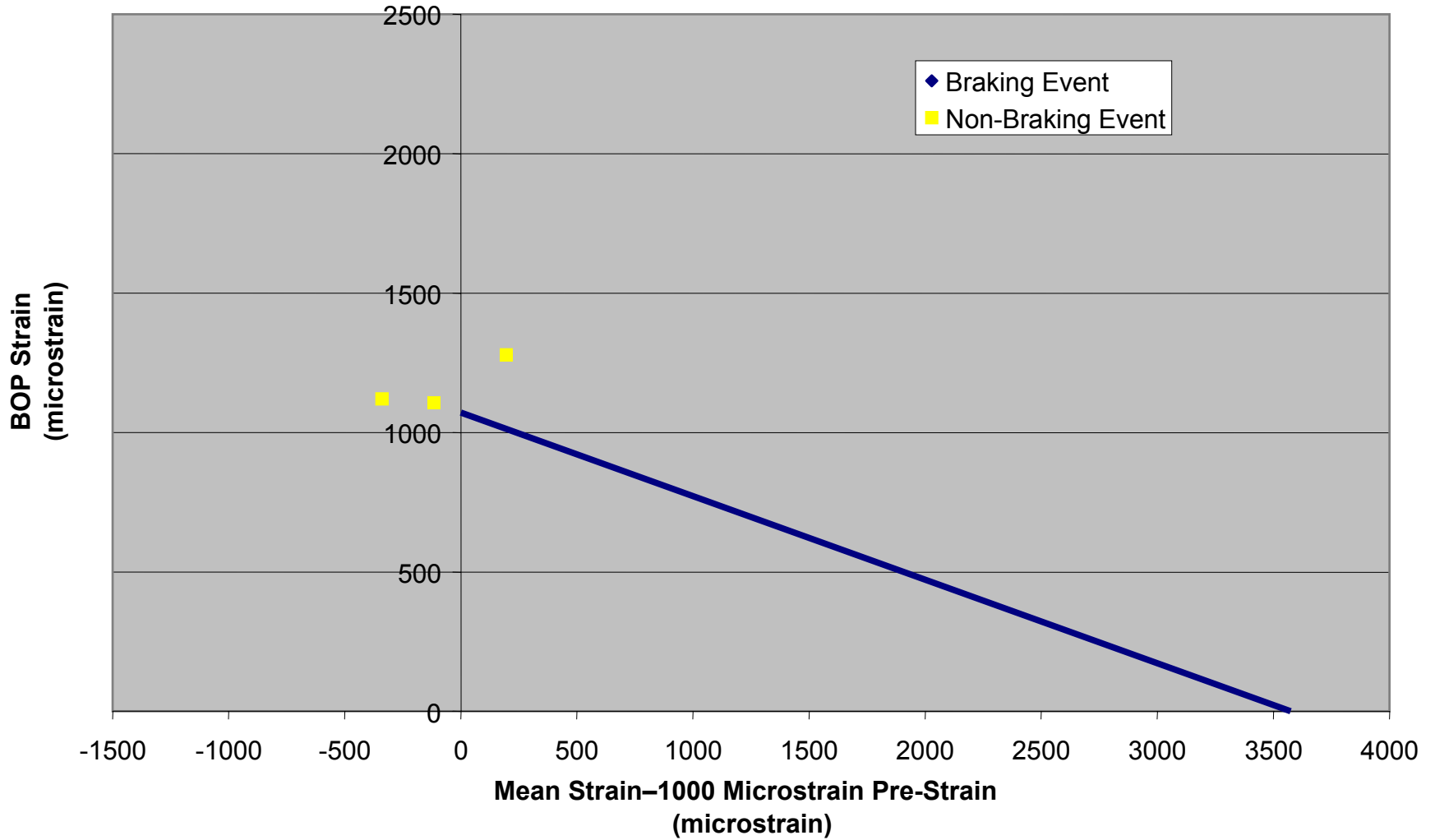

Mean Strain Versus Alternating Strain, Outer WABTEC/SAB-WABCO Disc, Spoke 6–May 16, 2005

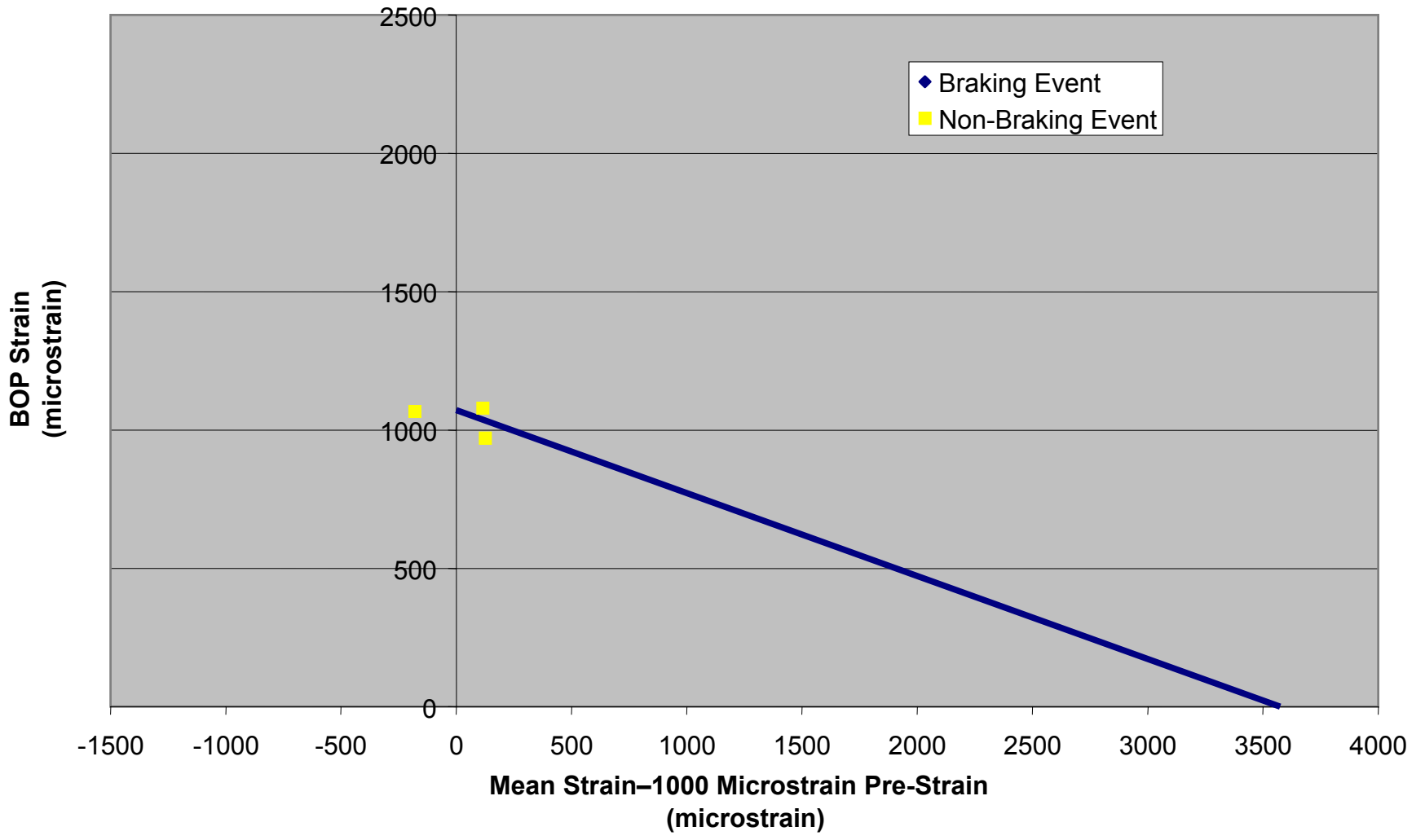

G-85

**Mean Strain Versus Alternating Strain, Center WABTEC/SAB-WABCO Disc,
Spoke 6—May 17, 2005**

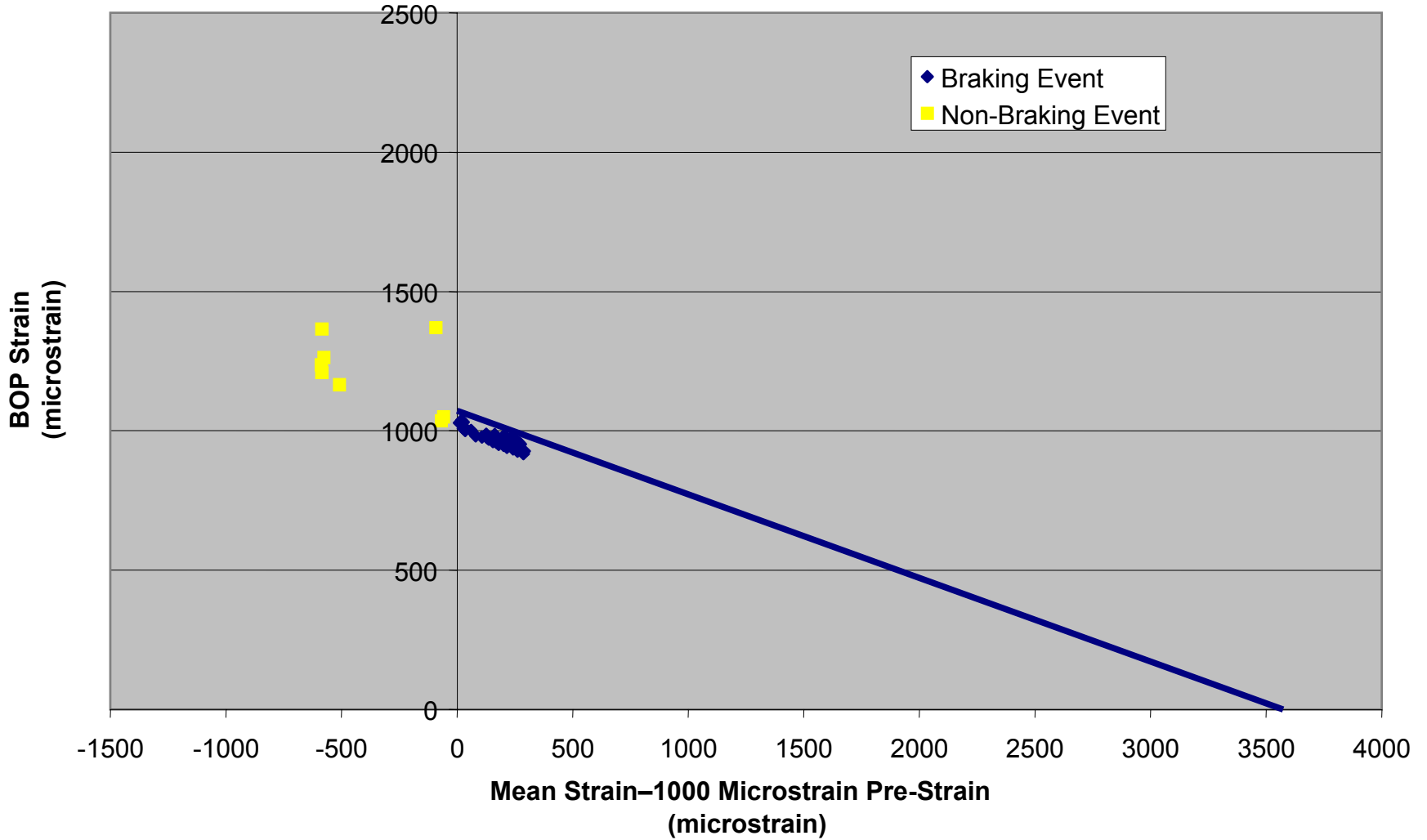

Mean Strain Versus Alternating Strain, Outer WABTEC/SAB-WABCO Disc, Spoke 6–May 17, 2005

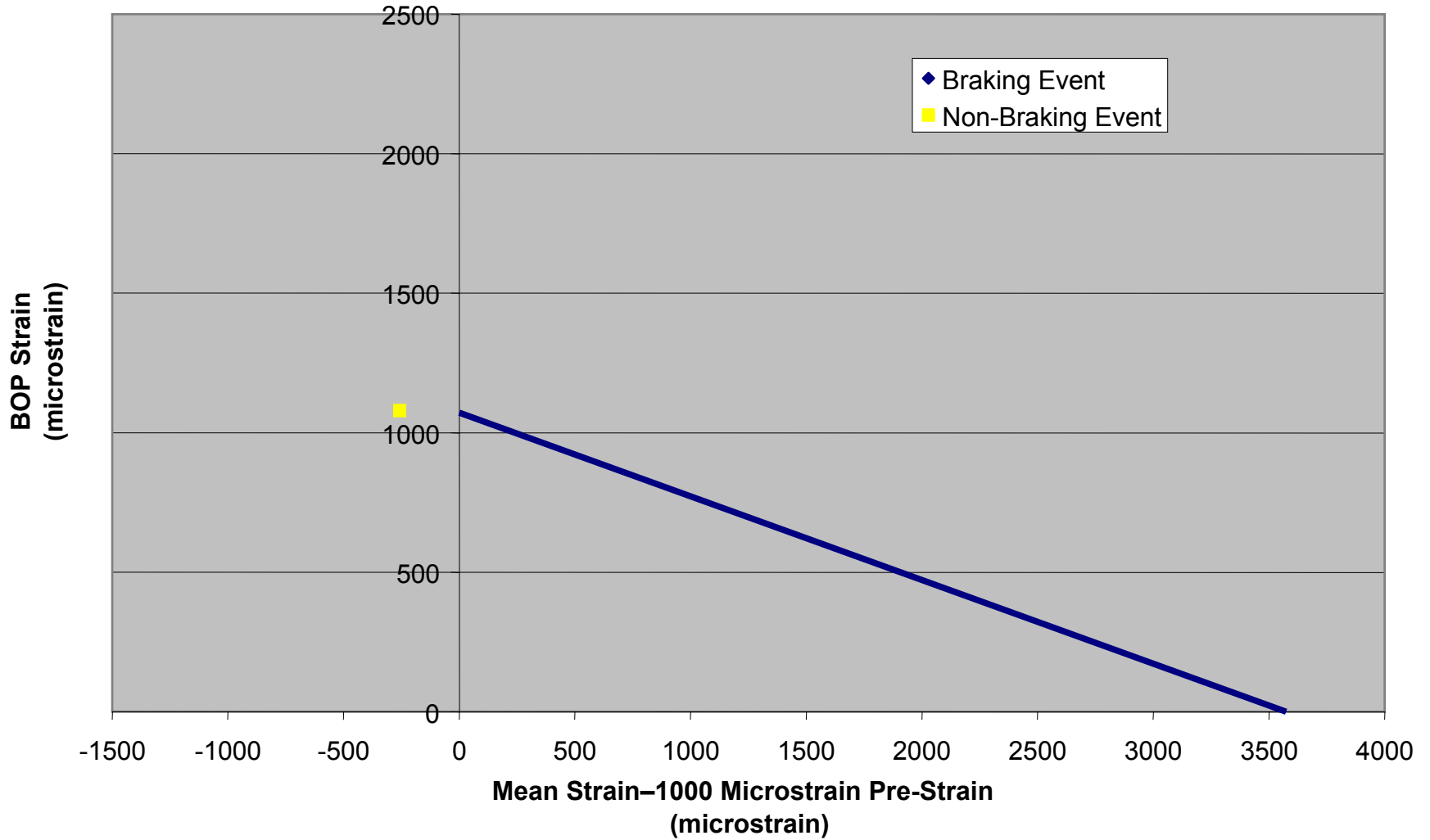

**Mean Strain Versus Alternating Strain, Center WABTEC/SAB-WABCO Disc,
Spoke 3—May 26, 2005**

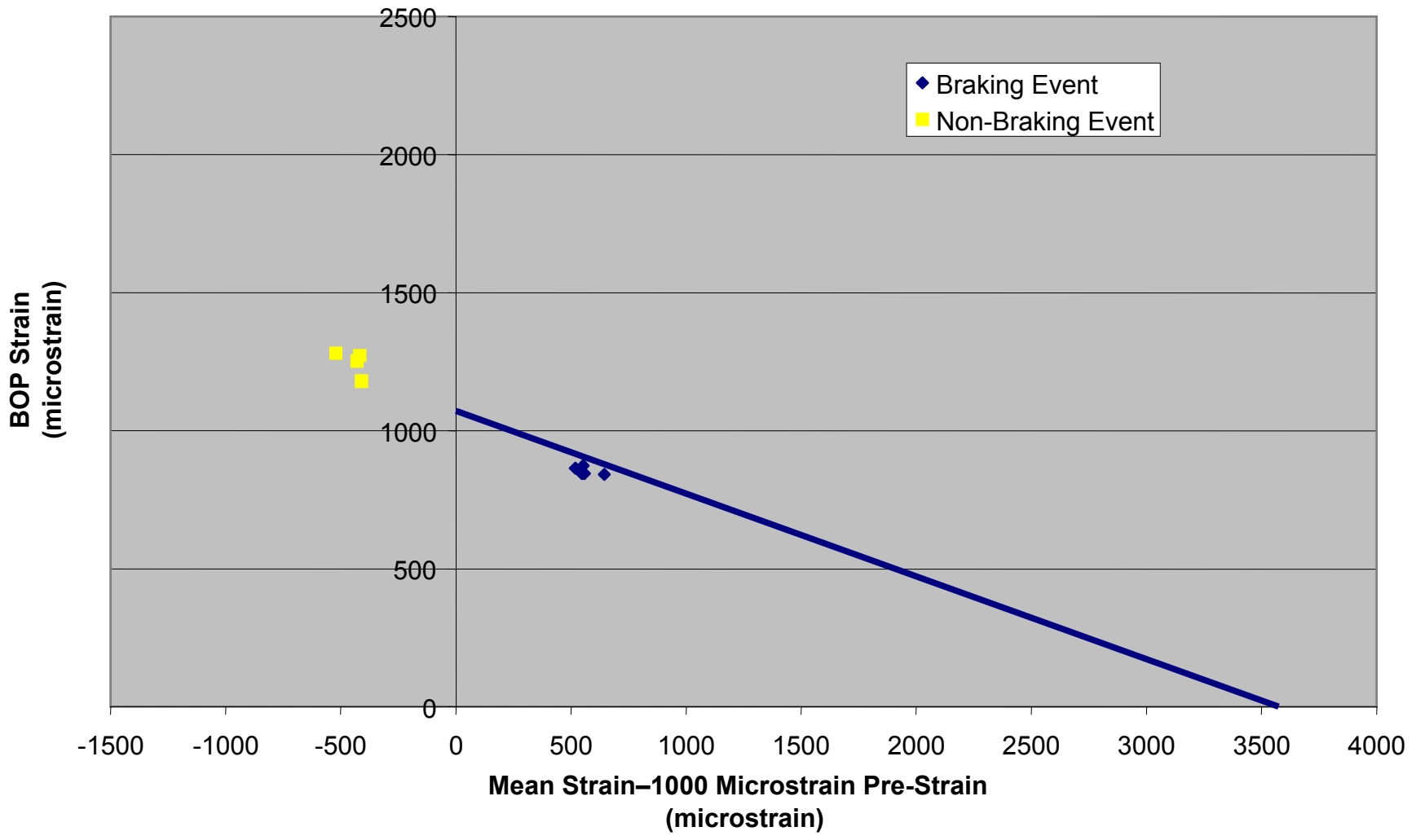

**Mean Strain Versus Alternating Strain, Center WABTEC/SAB-WABCO Disc,
Spoke 6–May 26, 2005**

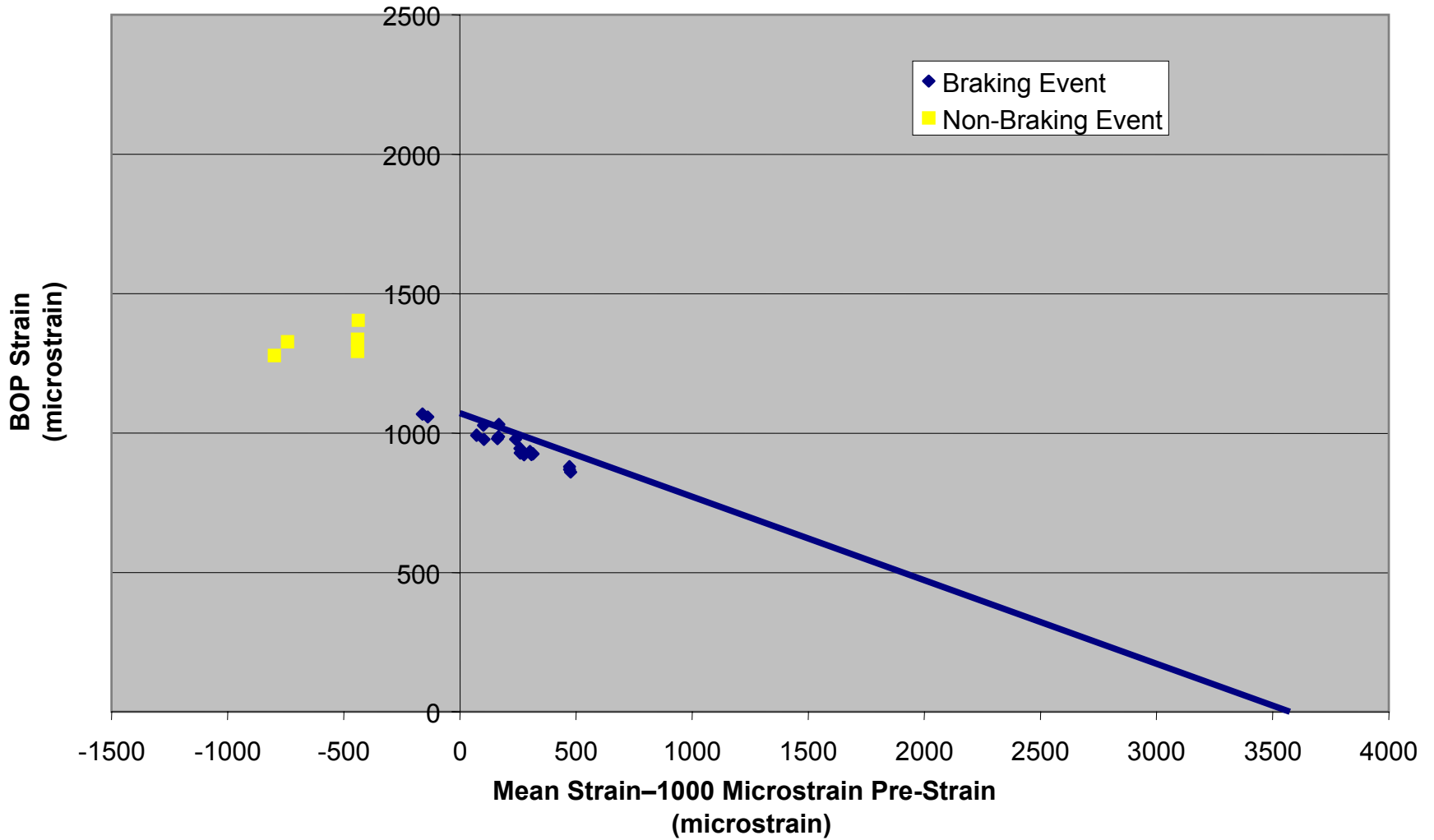

**Mean Strain Versus Alternating Strain, Center WABTEC/SAB-WABCO Disc,
Spoke 3–May 27, 2005**

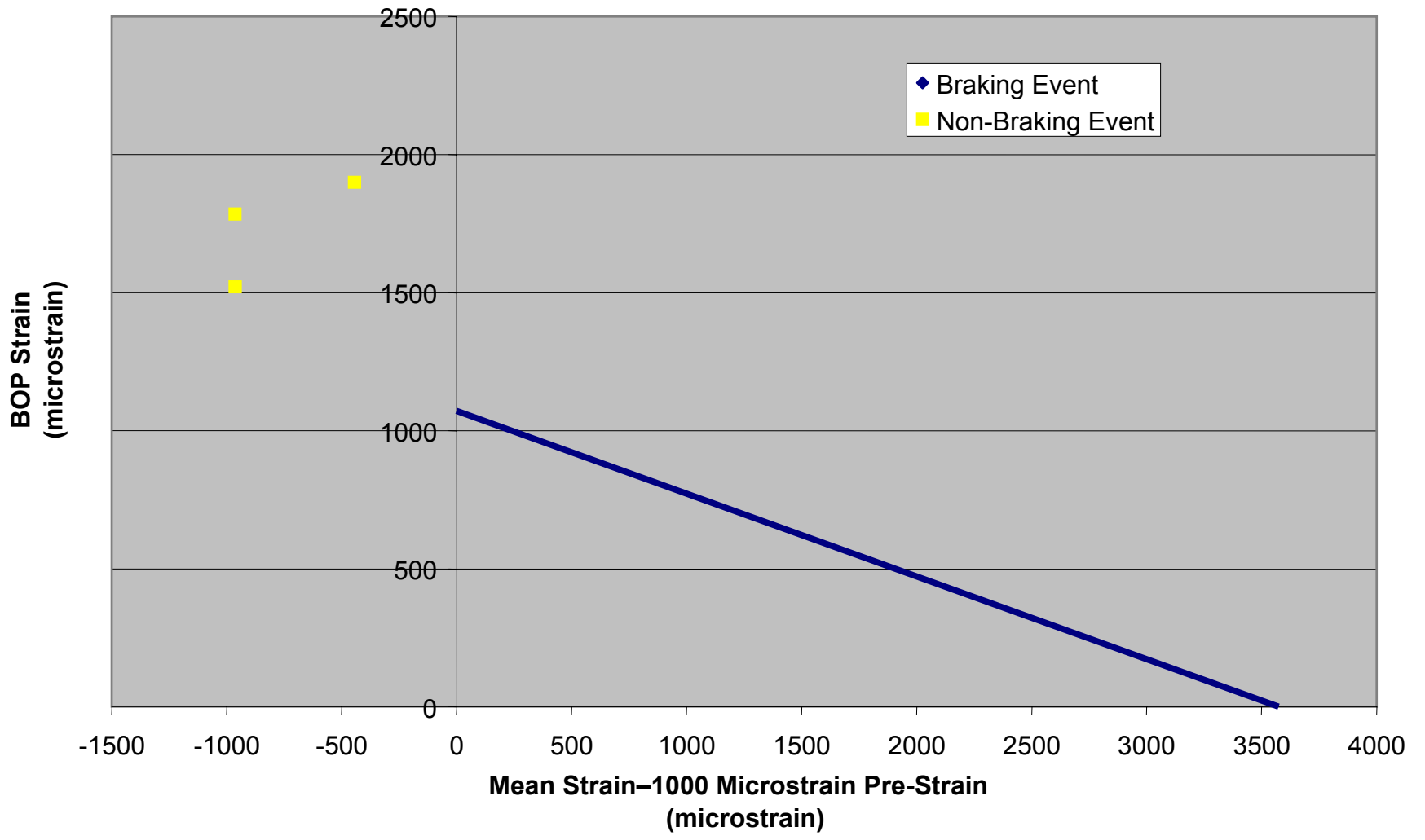

G-90

Mean Strain Versus Alternating Strain, Center WABTEC/SAB-WABCO Disc, Spoke 6–May 27, 2005

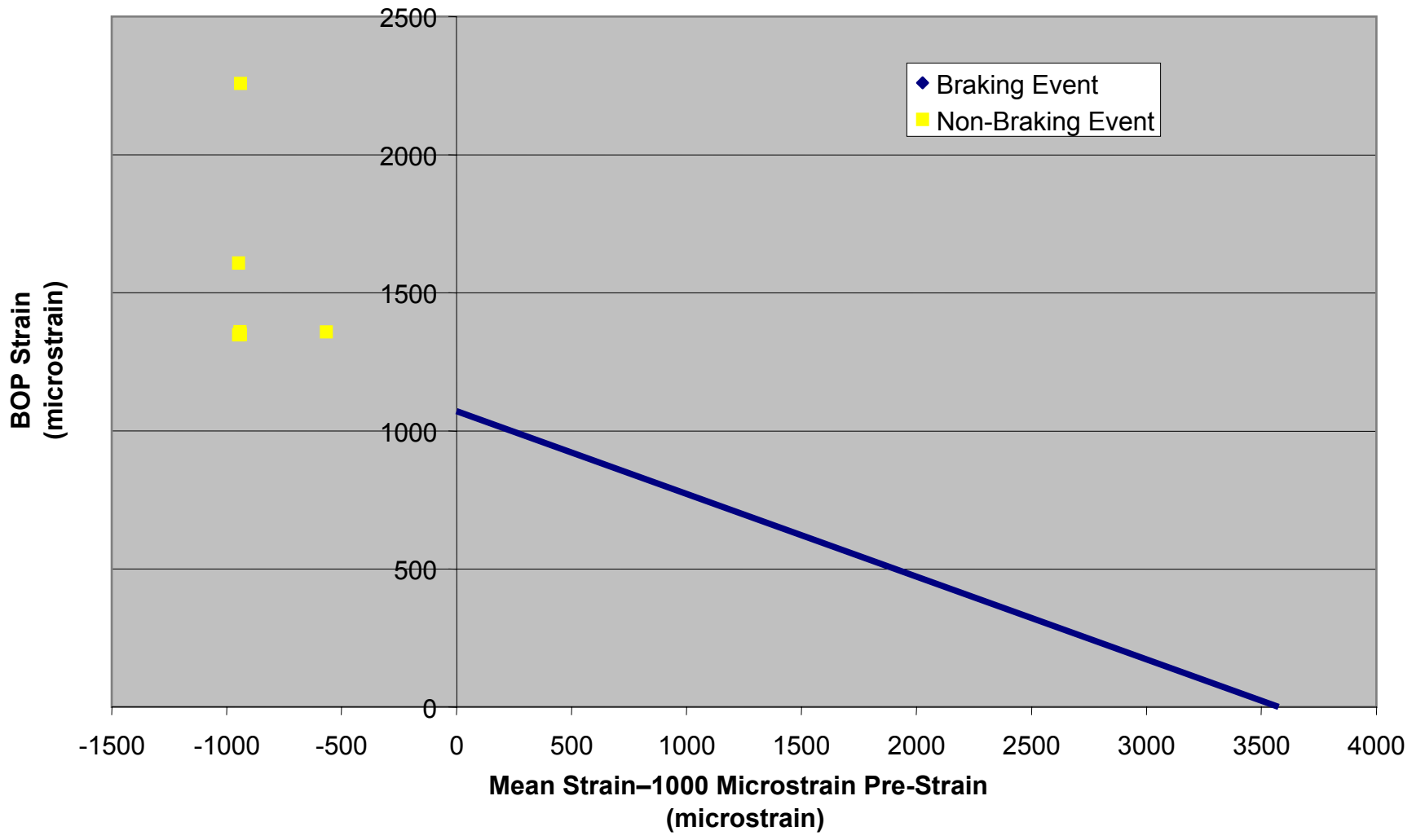

G-91

**Mean Strain Versus Alternating Strain, Center WABTEC/SAB-WABCO Disc,
Spoke 3–June 17, 2005**

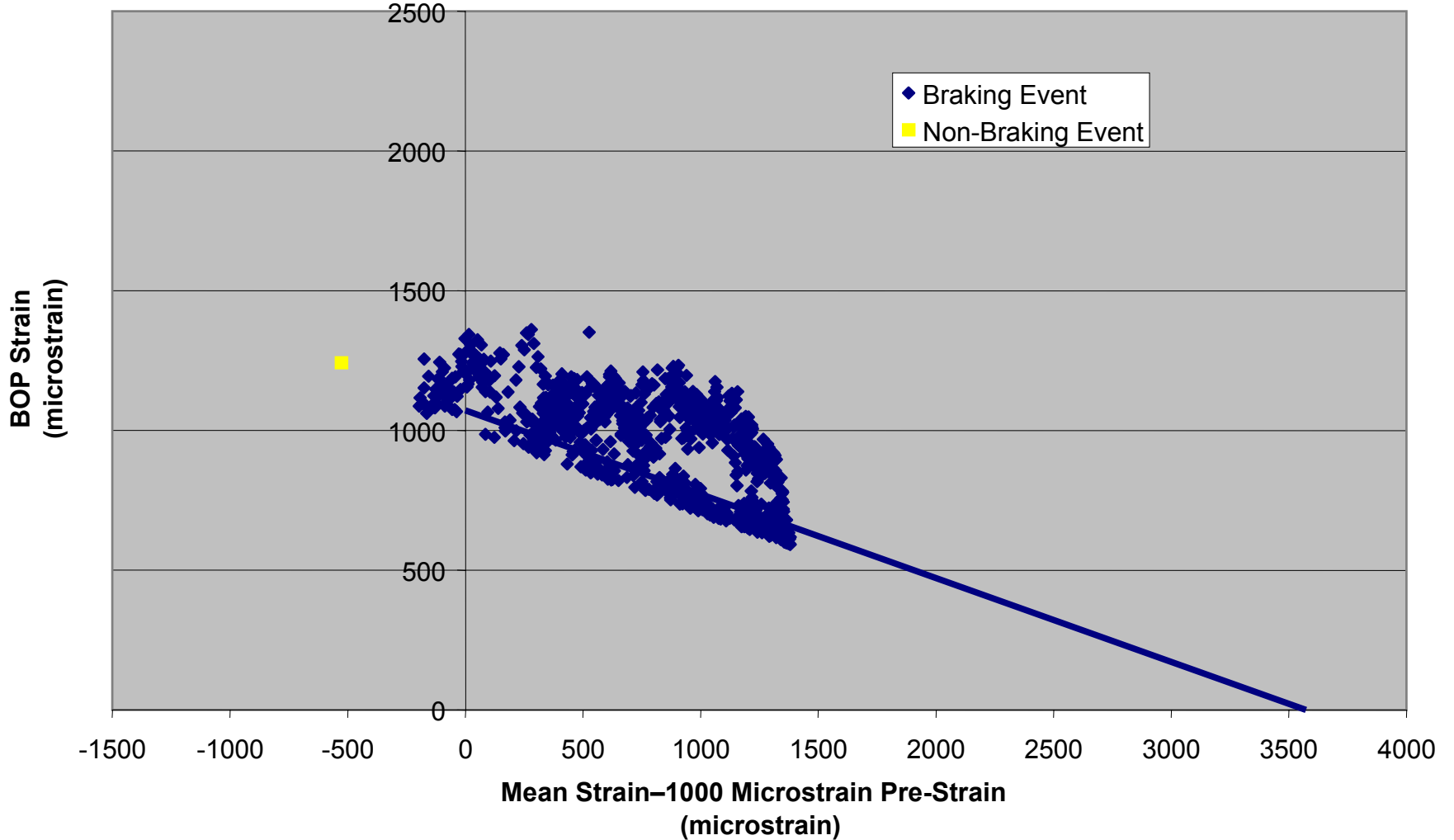

**Mean Strain Versus Alternating Strain, Center WABTEC/SAB-WABCO Disc,
Spoke 6—June 17, 2005**

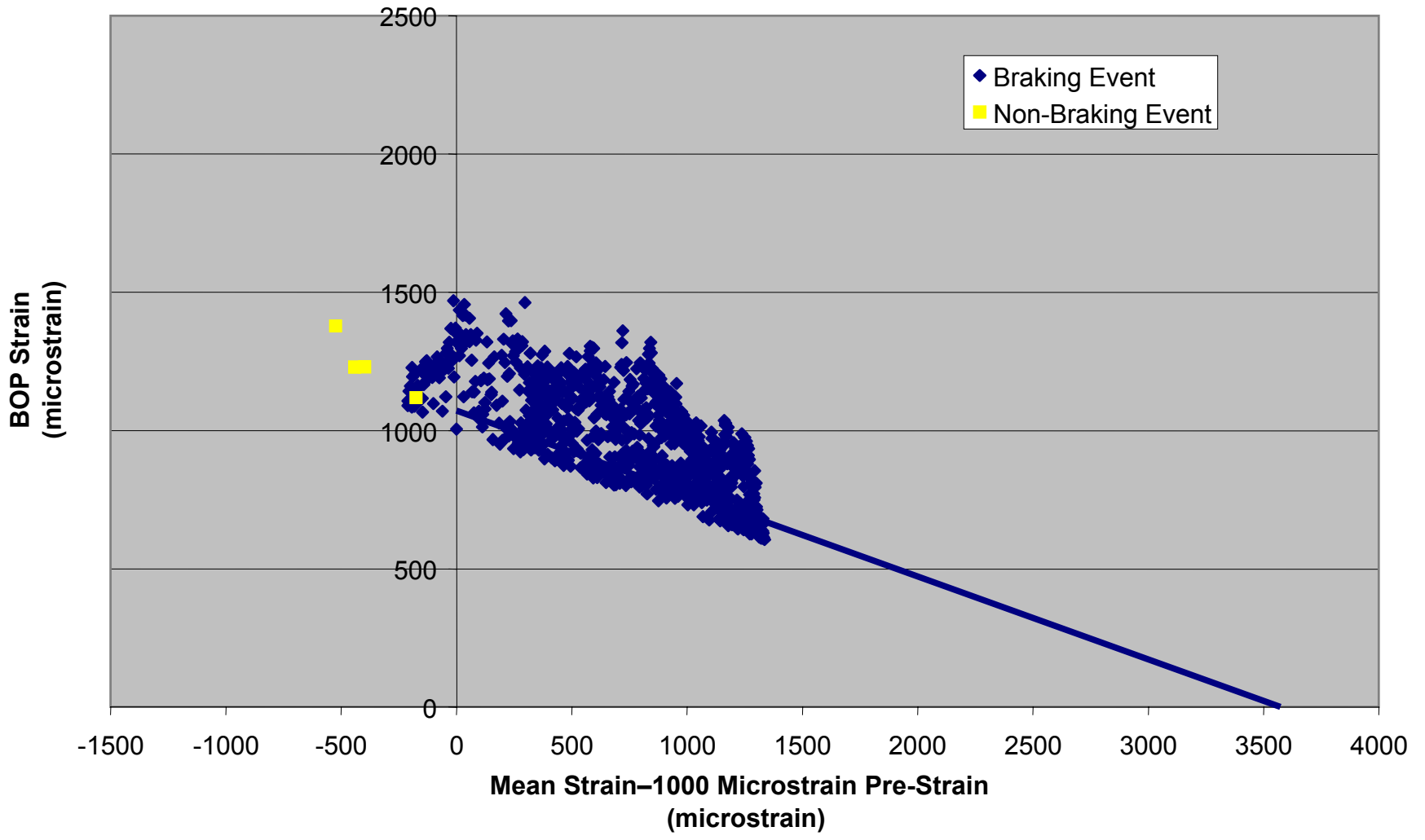

**Mean Strain Versus Alternating Strain, Center WABTEC/SAB-WABCO Disc,
Spoke 3—June 18, 2005**

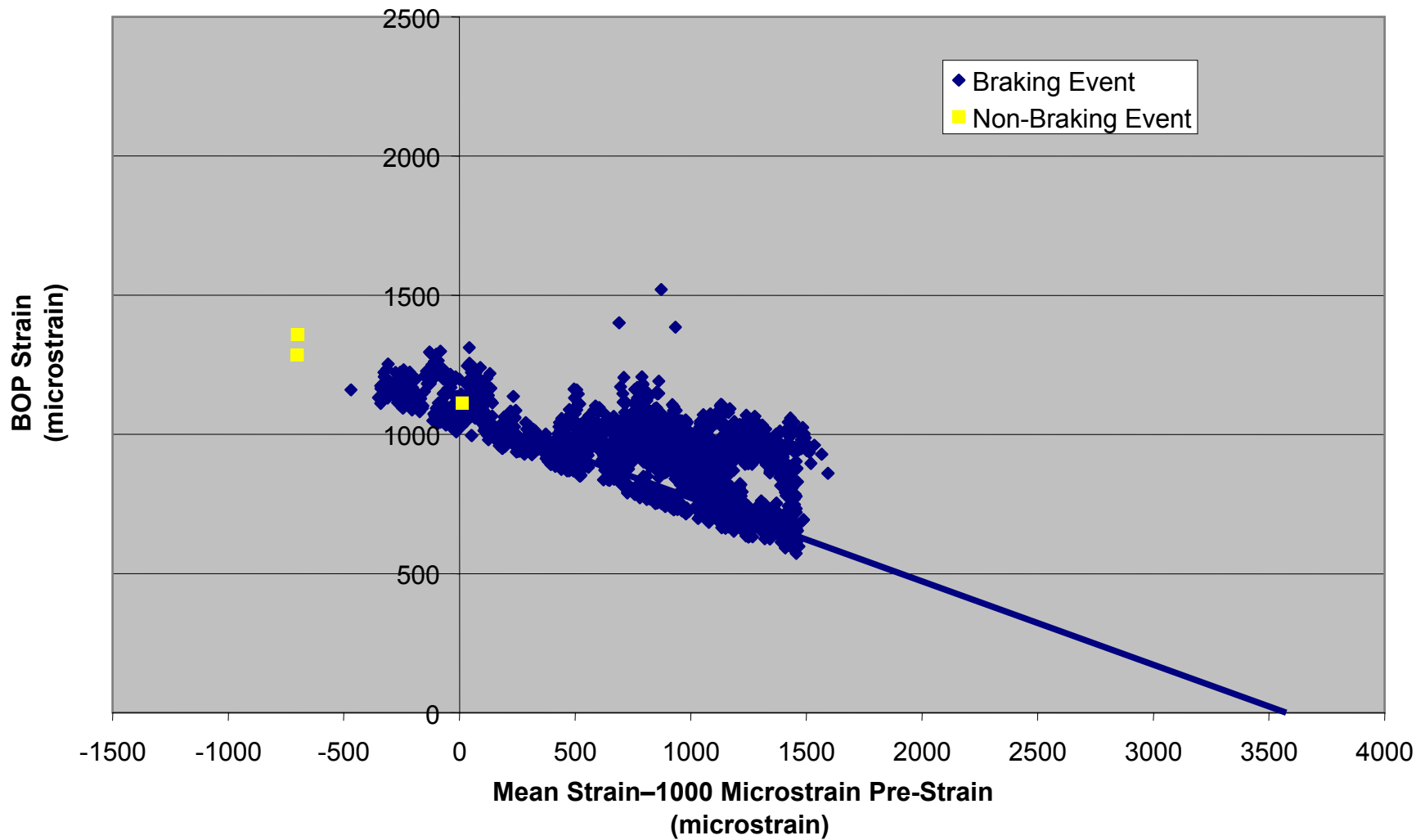

**Mean Strain Versus Alternating Strain, Center WABTEC/SAB-WABCO Disc,
Spoke 6—June 18, 2005**

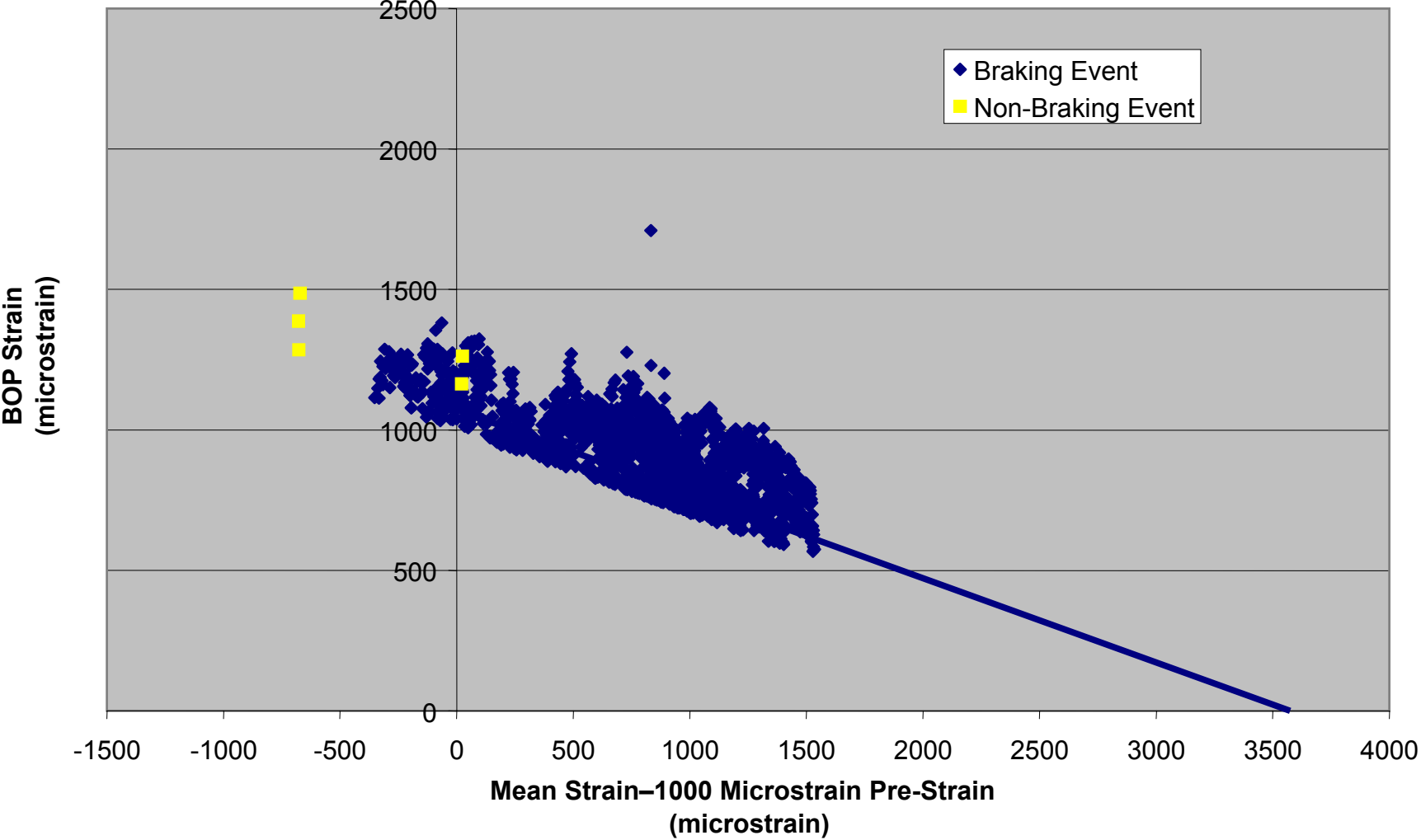

Knorr Disc

- In No Case Did The Knorr Disc Have A Combination Of Mean Strain And BOP Microstrain Levels That Meets The Level Of The Analysis Approach
- This Included Non-Braking And Braking Events

Summary

- Thermal Strains Build Up Quickly, But Have A Long Decay (Time Constant Of 7 Minutes Or More)–Levels Up To 2,500 Microstrain
- Sustained BOP Vibration In Braking Produces Largest Strain Observed In Test At ~187 Hz (Only Observed In Lead Axle Cases)
- Caliper Participates In This Vibration
- Shorter Bursts Of BOP Vibration Occur Throughout Testing And May Be Related To Vertical Acceleration Of Wheelset
- Vertical Acceleration On Bearing About Three Times Lateral Acceleration
- BOP Strain Can Have Amplitudes Of 1,500 Microstrain
- Combined Tensile And BOP Strain Can Be In The Range Of 2,700 (TBR) Microstrain Tension Taking Into Account 1,000 Microstrain Pre-Strain
- Yielding Occurs At 2,850 Microstrain (Based On Amtrak Provided Laboratory Test Results)
- The Pre-Stress Levels Were Examined For 2 WABTEC/SAB-WABCO Disc (Small Sample) And One Knorr Disc During Press On

Appendix H.

Axle Strain

Axle Strain

- Axle With WABTEC/SAB-WABCO Discs
 - At Two Stations Along Axle
 - Two Gages Per Station
 - 180° Difference In Circumferential Location
- Axle With Knorr Discs
 - At Two Stations Along Axle
 - Two Gages At One Station
 - Four Gages At The Other Station
 - 180° And 90° Difference In Circumferential Location

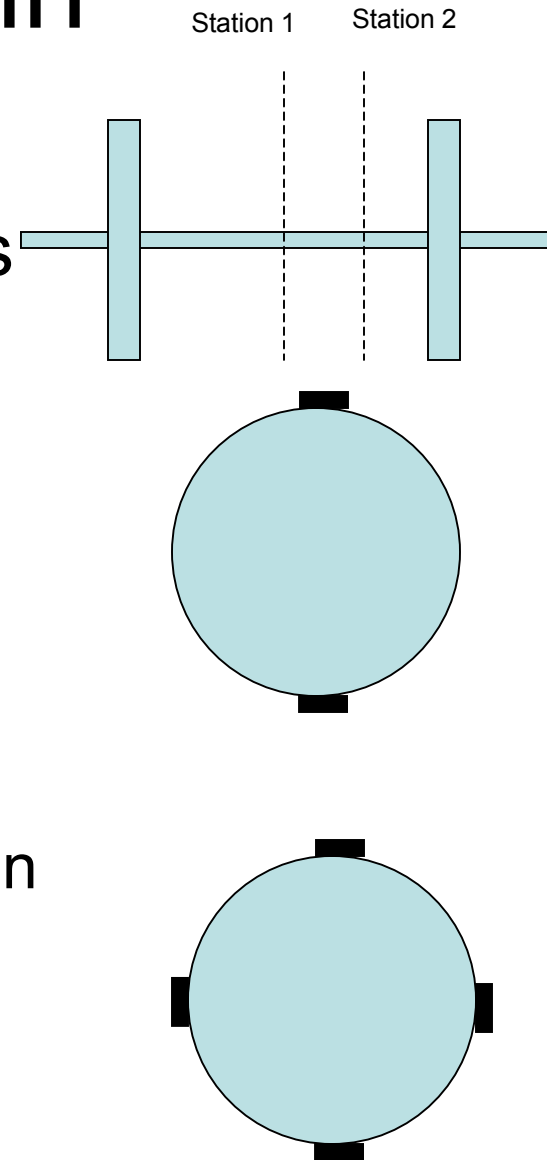

Axle Strain Analysis

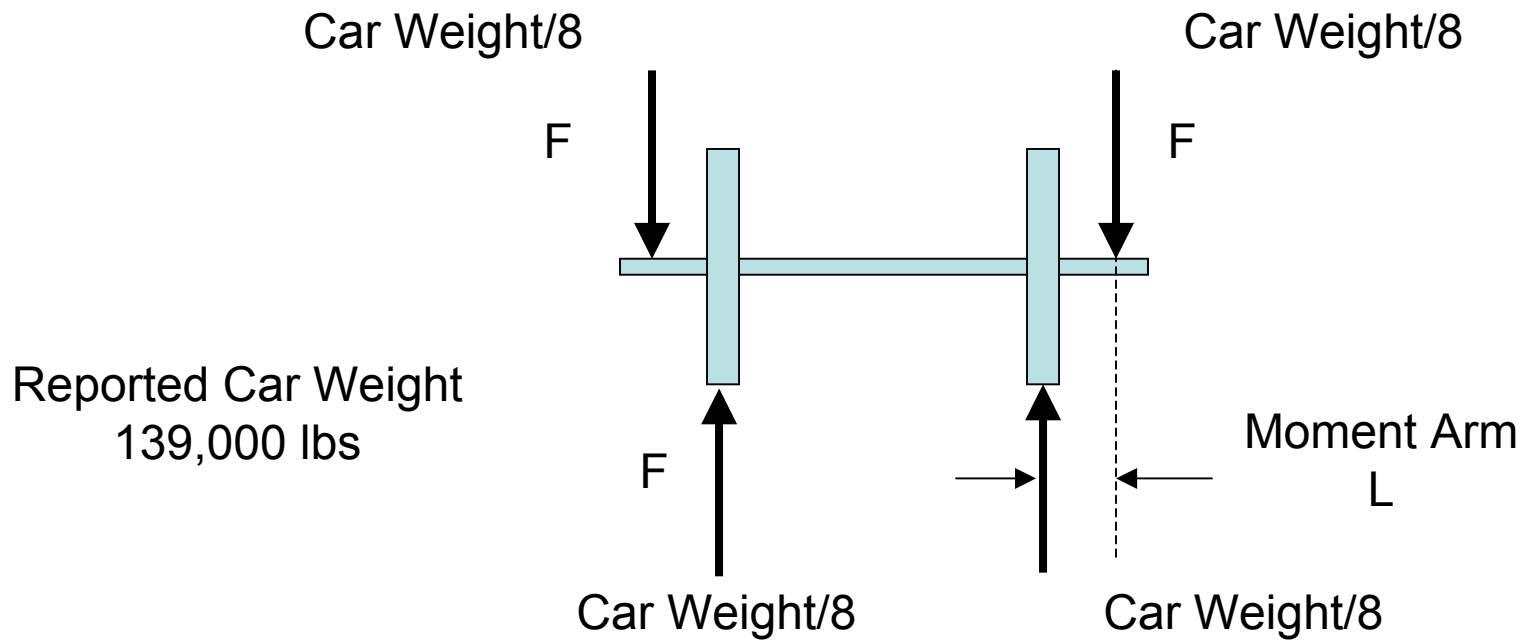

Bending Axle Strain

Axle Strain Gages

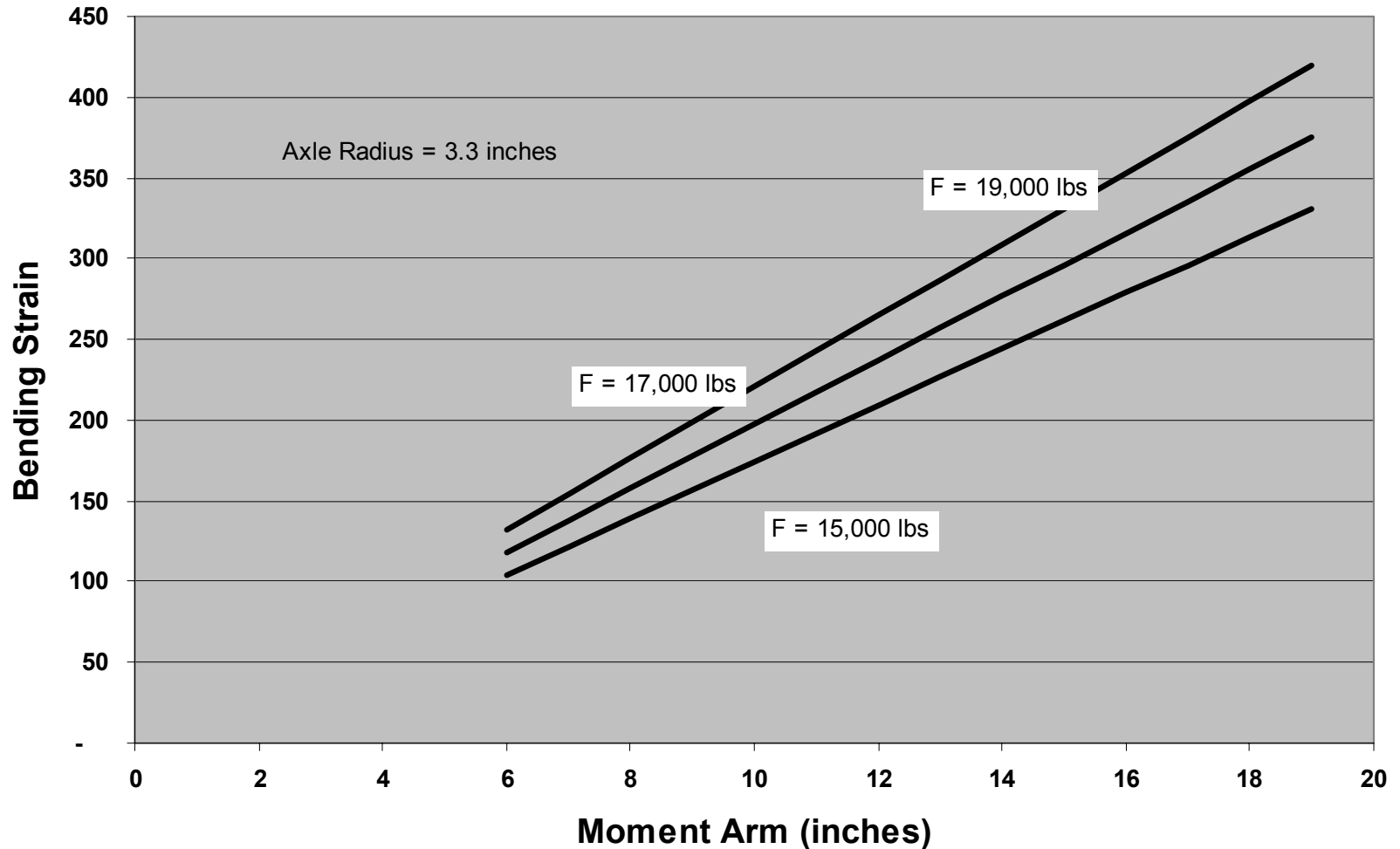

PSD Of Strain Signals

- The PSDs Of Strain Gage Signals Revealed Little Information For Either Axle
- Both Showed A Peak At The Wheel Revolution Frequency
- Co-Processing Of Two Channels Of Bending Signals May Provide A More Accurate PSD

Day 7-File 03

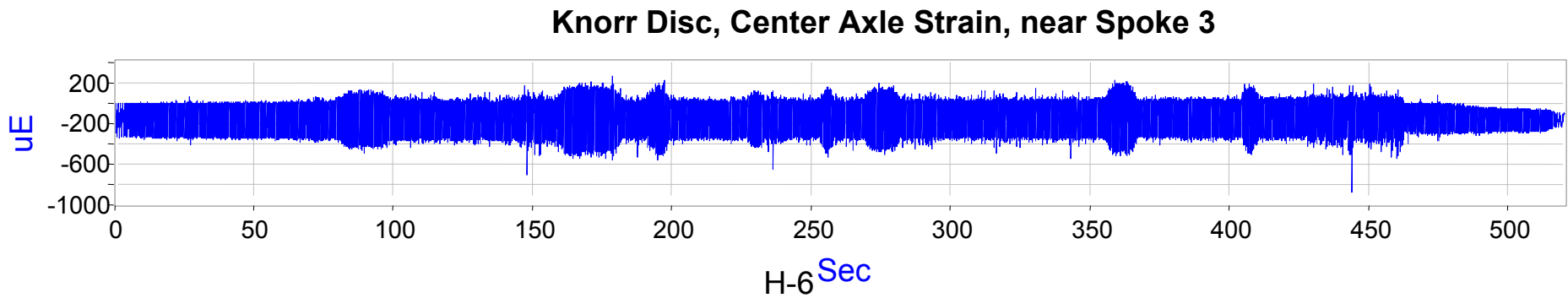
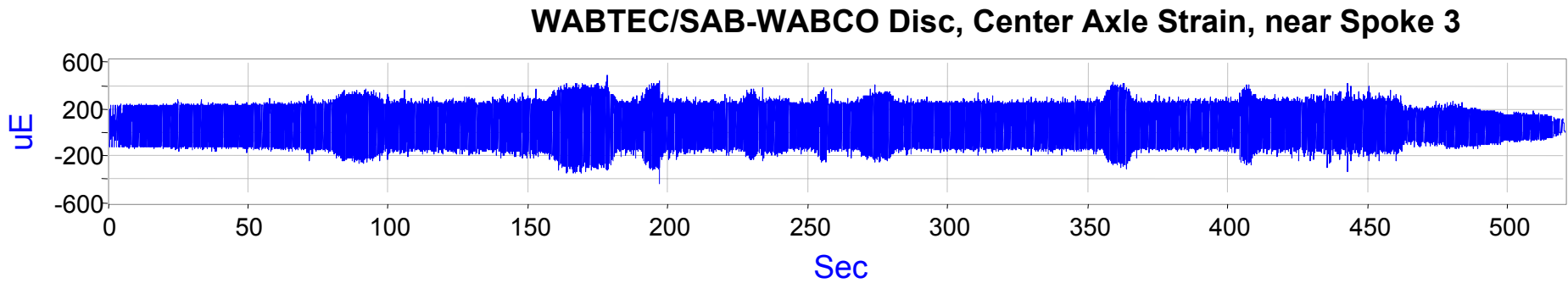
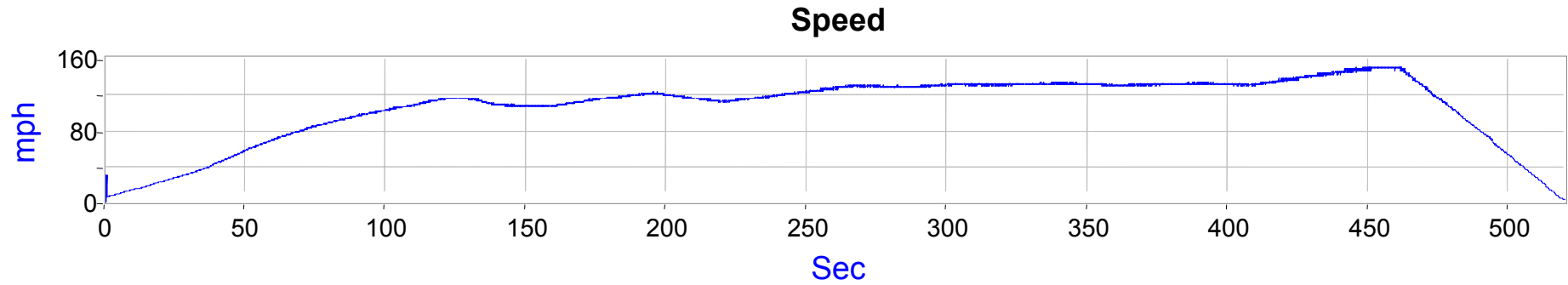

Day 7–File 03

**PSD of WABTEC/SAB-WABCO Disc Axle Strain near Spoke 3,
16384 points, 5 point moving avg, t = 300 s, speed = 130 mph**

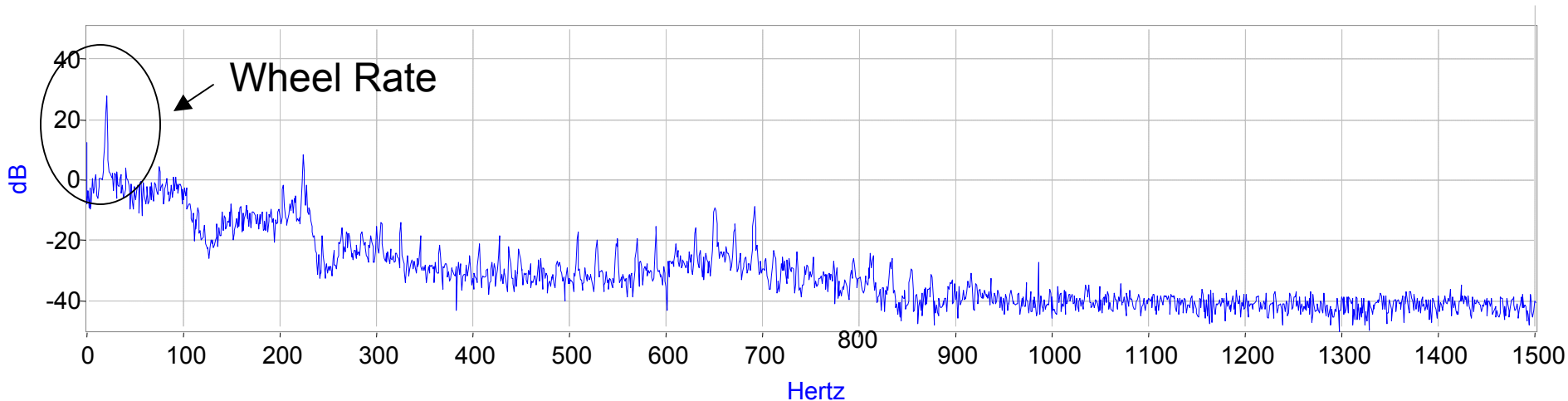

**PSD of Knorr Disc Axle Strain near Spoke 3,
16384 points, 5 point moving avg, t = 300 s, speed = 130 mph**

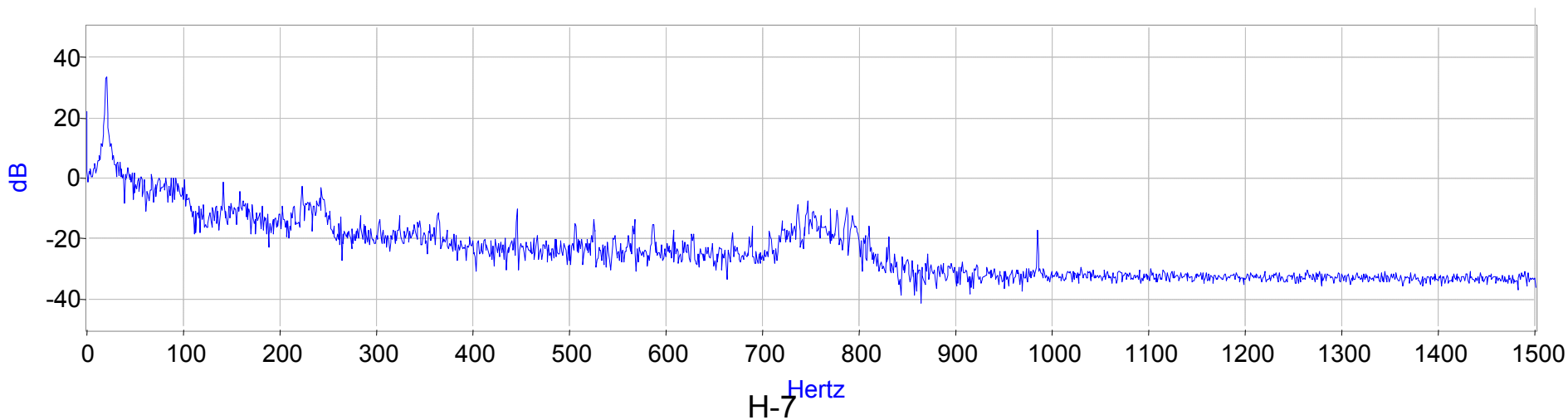

Day 7–File 03

demean(W1); overplot(demean(W2)); overplot(demean(W8)); overplot(demean(W9)); overplot(W5*10)

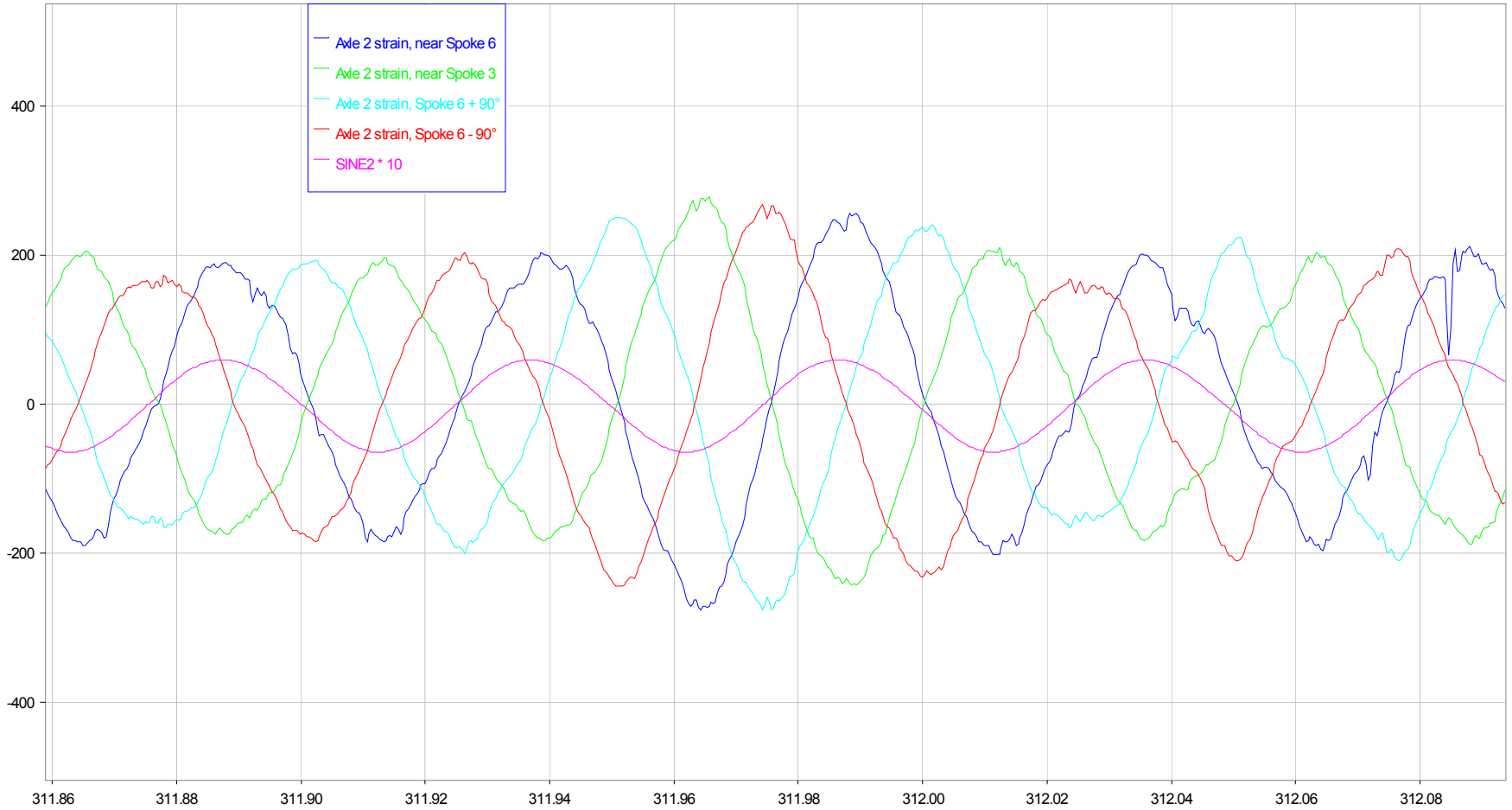

General Observations

- Modulated By Wheel Rate
- Long-Term Envelope Established By Unbalance On Curves
- This Envelope Can Be Determined By The Following Method
- Add The Absolute Values Of Two Bending Moment Stains That Are 90° Separated And Average Over Several Wheel Cycles
- Resultant Equals The Average Bending Moment Times ~ 1.2
- See Following Example

Axle Bending Moment

Simple Axle Bending Moment Processing

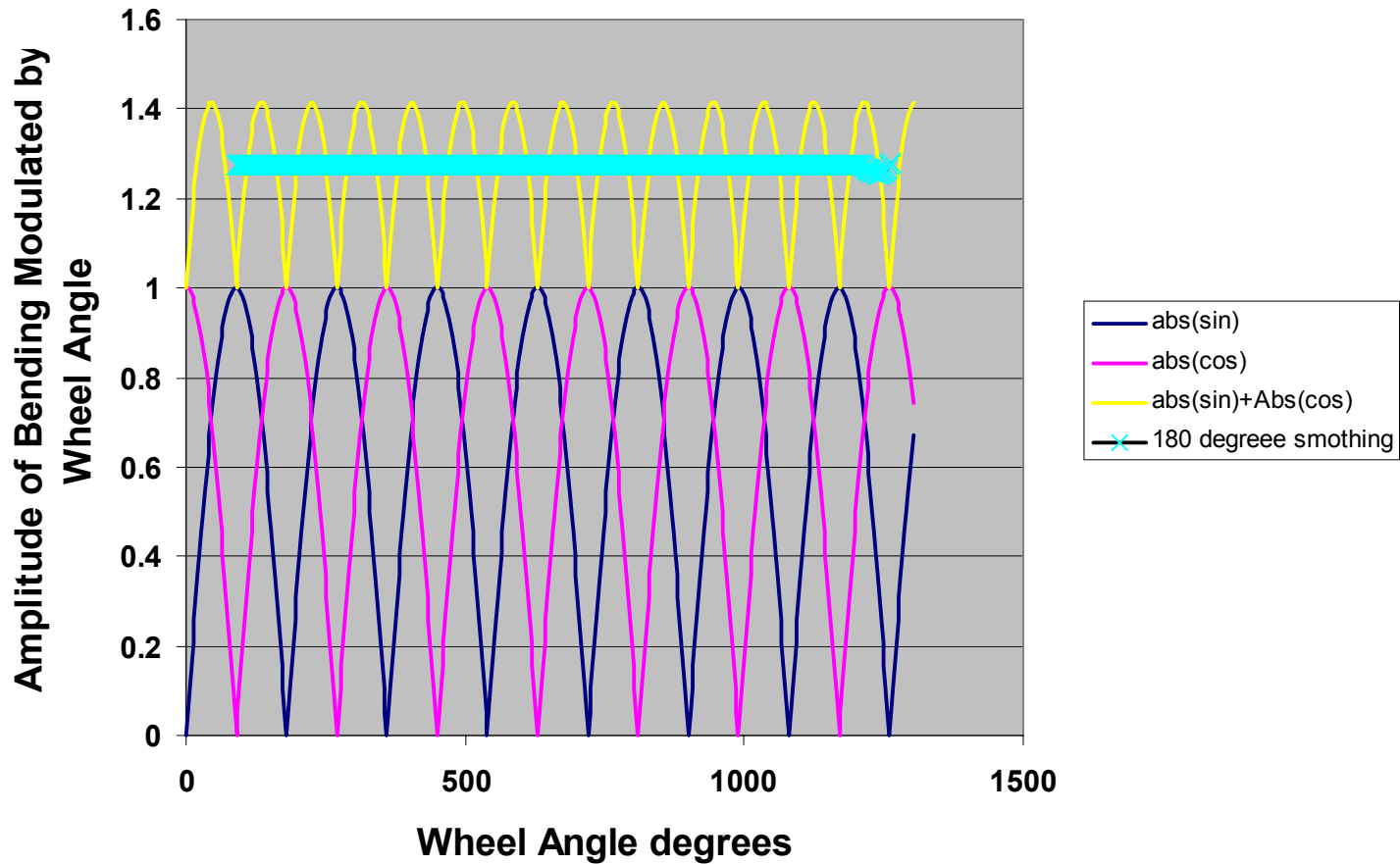

Day 7–File 03

Bending Moment Envelope

Correlation between Axle Strain amplitude and Truck Lateral Acceleration due to curvature

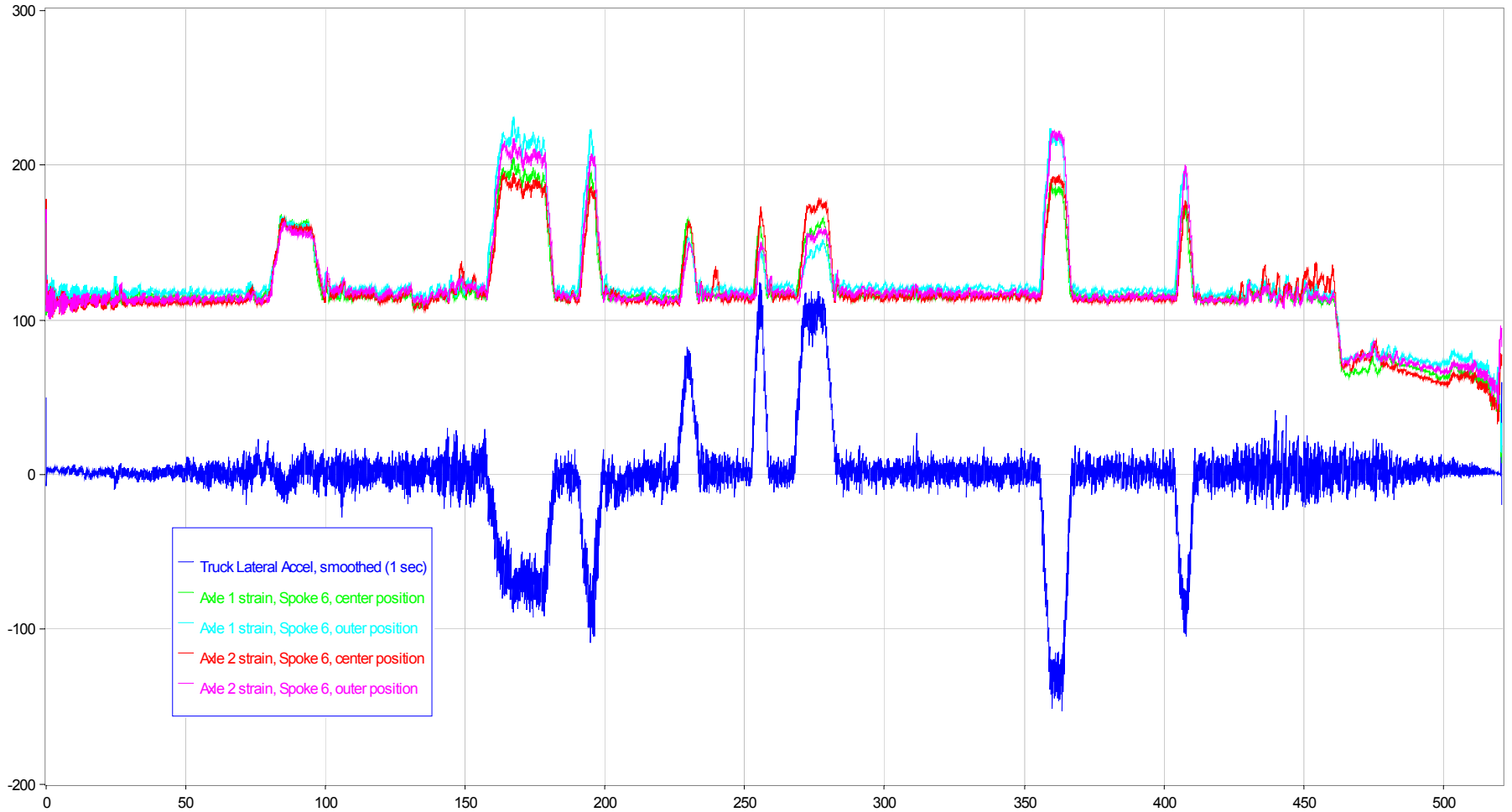

June 18–File 03

**PSD of WABTEC/SAB-WABCO Disc Axle Strain near Spoke 3,
16384 points, 5 point moving avg, t = 480 s, speed = 97 mph, during sustained oscill**

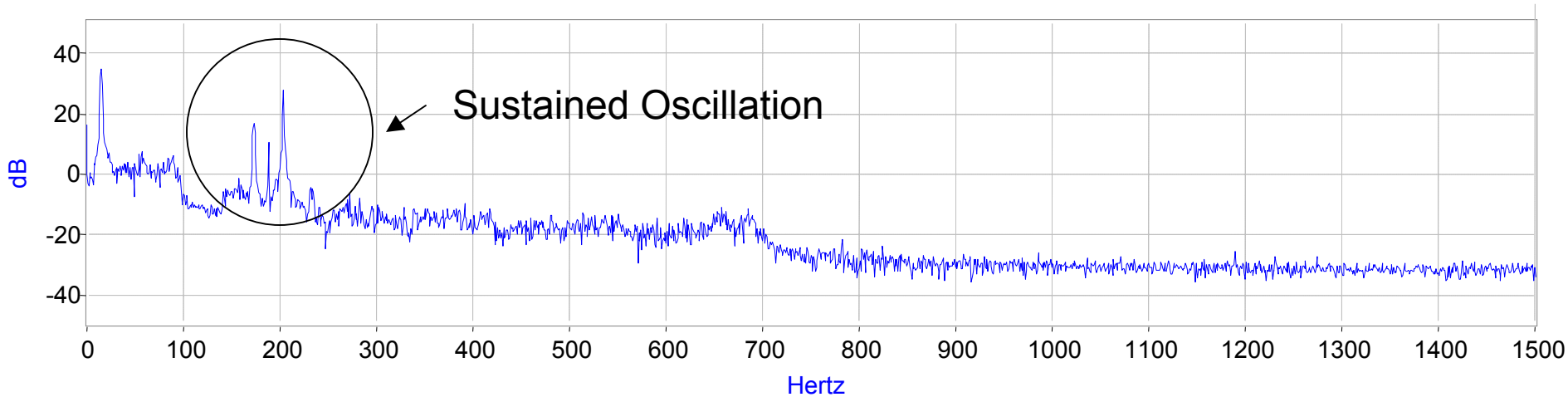

**PSD of Knorr Disc Axle Strain near Spoke 3,
16384 points, 5 point moving avg, t = 480 s, speed = 97 mph, during sustained oscill**

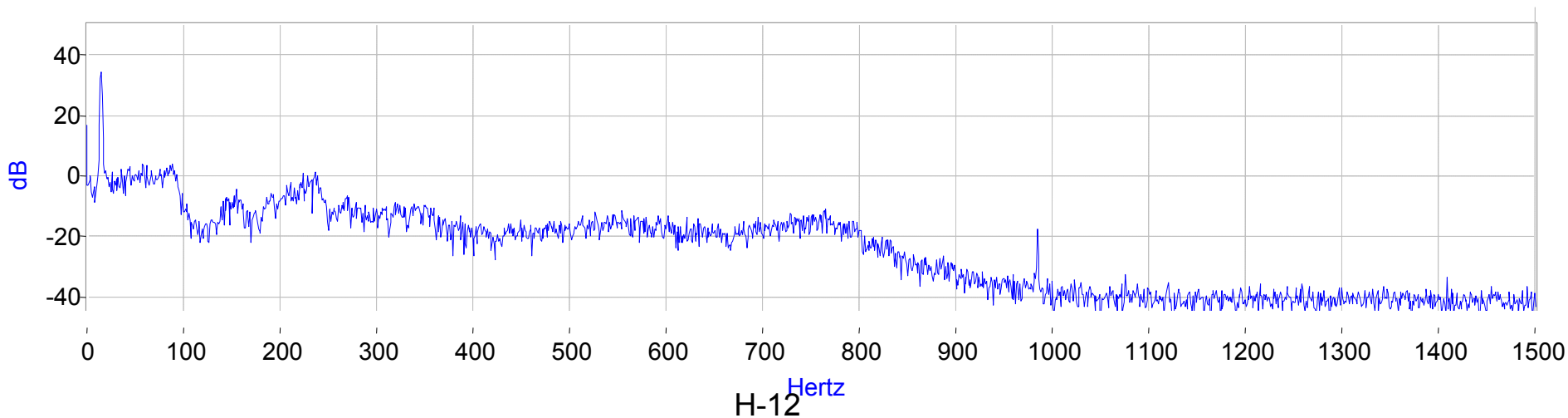

Extracting The Two Orthogonal Bending Moments

- This Method Can Be Used When Two Bending Moment Gages Are 90° Apart
- The First Bending Moment Is In The Vertical Plane
- The Second Bending Moment Is In The Horizontal Plane
- See The Next Series Of Slides For Method

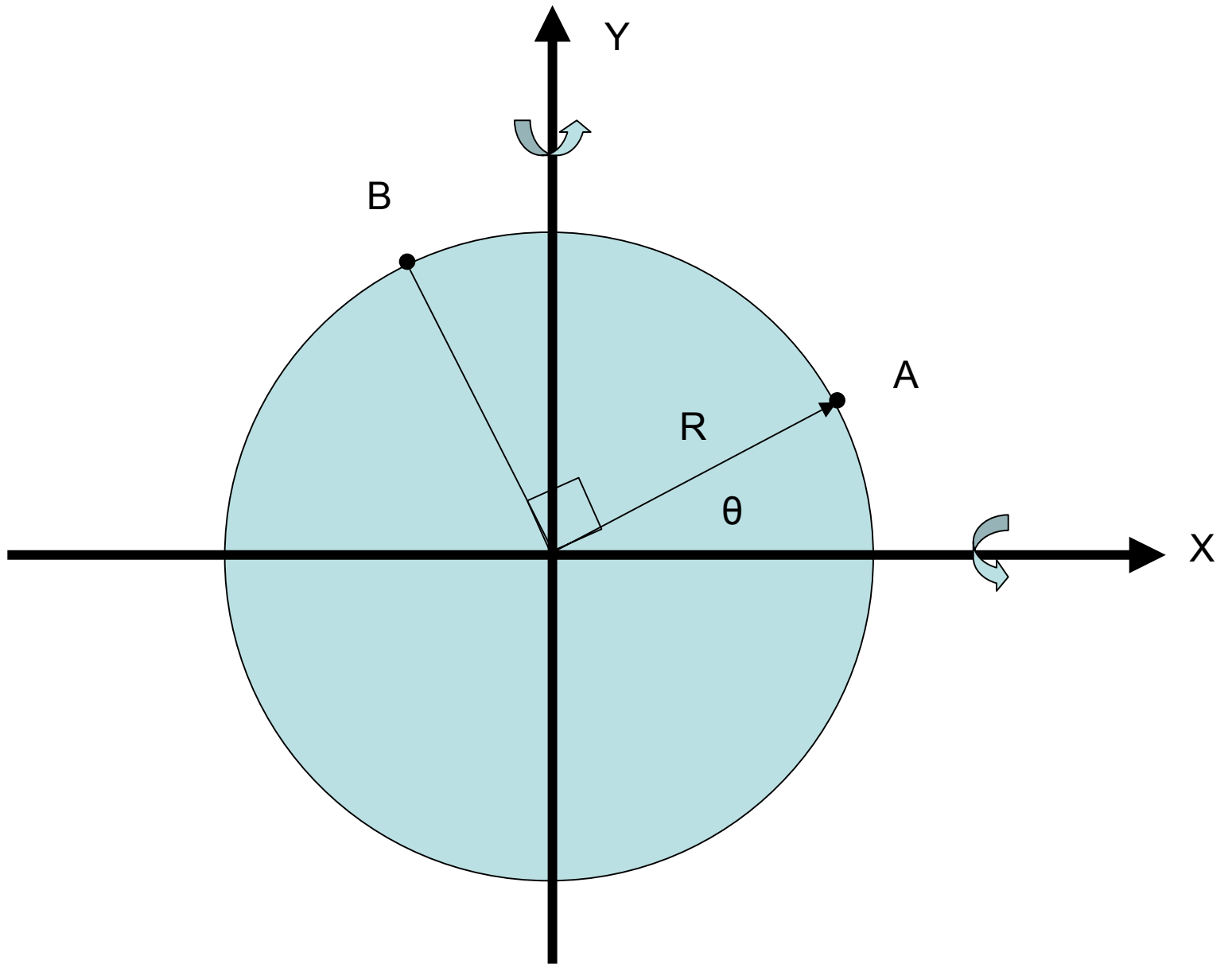

H-14

Combined Bending Strain

$$\varepsilon_T = \varepsilon_x + \varepsilon_y$$

$$\varepsilon_x = \frac{-M_x X_A}{I}$$

$$\varepsilon_y = \frac{-M_y Y_A}{I}$$

$$\varepsilon_A = \frac{M_x X_A}{I} - \frac{M_y Y_A}{I}$$

$$X_A = R \sin \theta \quad Y_A = R \cos \theta$$

$$\varepsilon_T = \frac{M_x R \sin \theta}{I} - \frac{M_y R \cos \theta}{I}$$

Strain At Points A And B

$$\varepsilon_A = \frac{M_x R \sin \theta}{I} - \frac{M_y R \cos \theta}{I}$$

$$\varepsilon_B = \frac{M_x R \sin(\theta + 90^\circ)}{I} - \frac{M_y R \cos(\theta + 90^\circ)}{I}$$

Given ε_A , ε_B and θ

Two Equations And Two Unknowns M_x And M_y

Combined Bending

$$\cos(\theta + 90^\circ) = \cos \theta \cos 90^\circ - \sin \theta \sin 90^\circ = -\sin \theta$$

$$\sin(\theta + 90^\circ) = \sin \theta \cos 90^\circ + \cos \theta \sin 90^\circ = \cos \theta$$

$$\varepsilon_A = \frac{M_x R \sin \theta}{I} - \frac{M_y R \cos \theta}{I}$$

$$\varepsilon_B = \frac{M_x R \cos \theta}{I} + \frac{M_y R \sin \theta}{I}$$

Combined Bending

$$M_x = \left(\frac{I}{R} \right) (\varepsilon_A \sin \theta + \varepsilon_B \cos \theta)$$

$$M_y = \left(\frac{I}{R} \right) (+\varepsilon_A \cos \theta - \varepsilon_B \sin \theta)$$

Extracting The Two Orthogonal Bending Moments

- This Approach Has Not Been Implemented
- It Would Be Implemented To:
 - Observe The Full Dynamic Behavior Of Disc Bending
 - Observe The Bending Modes Of The Axle In Both The Horizontal And Vertical Planes
 - Since The BOP Mode During Braking Has Maximum Displacement In The Horizontal Plane, This Information Could Be Important To Understand The Axle Disc Interaction

Appendix I. Temperature

<u>Section</u>	<u>Page</u>
Basic Concepts	I-2
Temperature Measurements	I-8
Spoke Strains and Temperature	I-21
Heating and Cooling of Discs	I-36

Basic Concepts

Ambient Temperatures

- Temperatures Measured On The Disc Are The Combined Effect Of The Heating Of The Disc During Braking And Ambient Temperature
- Ambient Temperatures For Each Test Day Are Provided In The Following Table

Table I.1. Ambient Temperatures Over The Test Days At Four Primary Locations

Temperatures on the Test Days					
Day	Wash DC	Philadelphia	New York	Boston	Max-Min
16th May	65	68	63	50	18
17th May	68	70	63	58	12
26th May	70	58	60	53	17
27th May	80	82	76	59	23
17th Jun	75	70	71	58	17
18th Jun	80	75	74	56	24

Note: Temperatures Noted Above Are Approximately The Ambient Temperatures At The Locations Listed When Trainset 10 Arrived At The Station

Source: www.wunderground.com

Disc Expansion Model

- Simple Model To Determine Reasonable Values Of Mean Spoke Strain Due To Temperature Increase of Friction Rings
- Based On Friction Ring Unrestrained Expansion
- Assumes Spokes Follow Friction Ring

Thermal Expansion Of Friction Rings

Circumference of friction plate expands with increased temperature

α = coefficient of thermal expansion

$$C(T) = C_0(1 + \alpha T)$$

R_0 Radius at point A

R Radius at point A with increased temperature

$$(R - R_0) = C_0 \alpha T / 2\pi$$

Strain in Spoke of Length L due to temperature change

$$(R - R_0) / L = C_0 \alpha T / 2\pi L = \text{Tensile Strain}$$

L = Length of Spoke

Thermal Expansion Of Friction Rings

- $C_o = 67$ inches
- $L = 7$ inches
- $A = 7 \cdot 10^{-6} / \text{degree F}$
- Spoke Strain/Degree F = 10.7μ Strain/F $^\circ$
- Spoke Resists Expansion, So The Resulting Strain In Spoke Should Be Less Than This Value

Temperature Measurements

Temperature Measurements

- Two Types Of Temperature Sensors Were Used During Testing:
 - IR Sensors
 - Thermocouples
- The IR Sensors Were Aimed At The Friction Surface At Approximately A 90° Angle

Temperature Sensors

- IR Sensor
 - Aimed At Friction Surface
 - Non-Contact
 - Fast Response
- Thermocouple
 - Attached To Back Of Friction Surface
 - Rotates With Axle
 - Slow Response–Requires Back Of Friction Plate To Heat Up

Comparison Of IR And Hand Thermocouple Measurements

Comparison of Hand Thermocouple Measurements with IR Temperature Measurement, Left Side of Center WABTEC/SAB-WABCO Disc–May 16, 2005

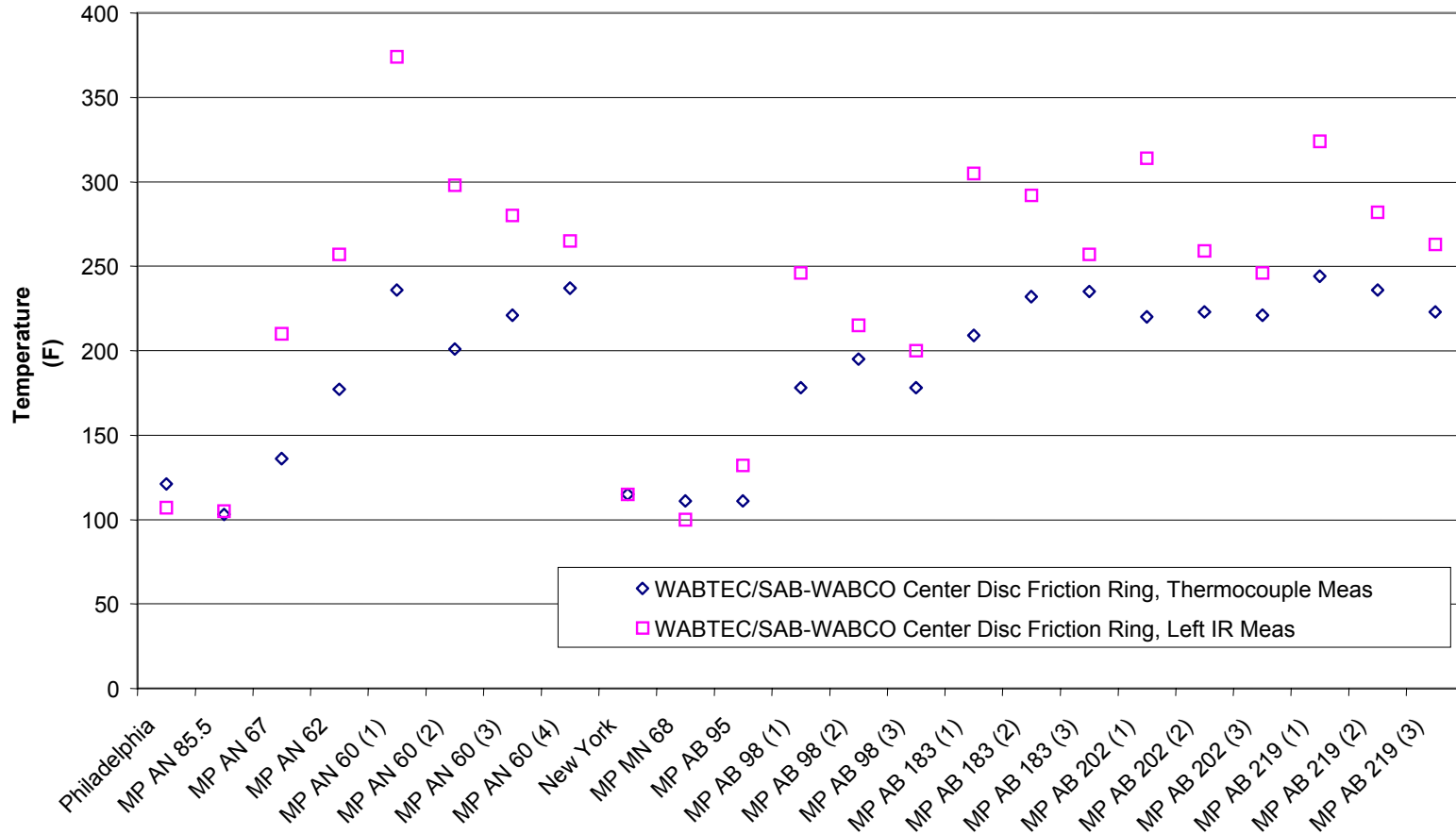

Temperature Measurements Made on May 17, 2005,
Between Newark, NJ, and Philadelphia, PA—File 051705_19.ABT

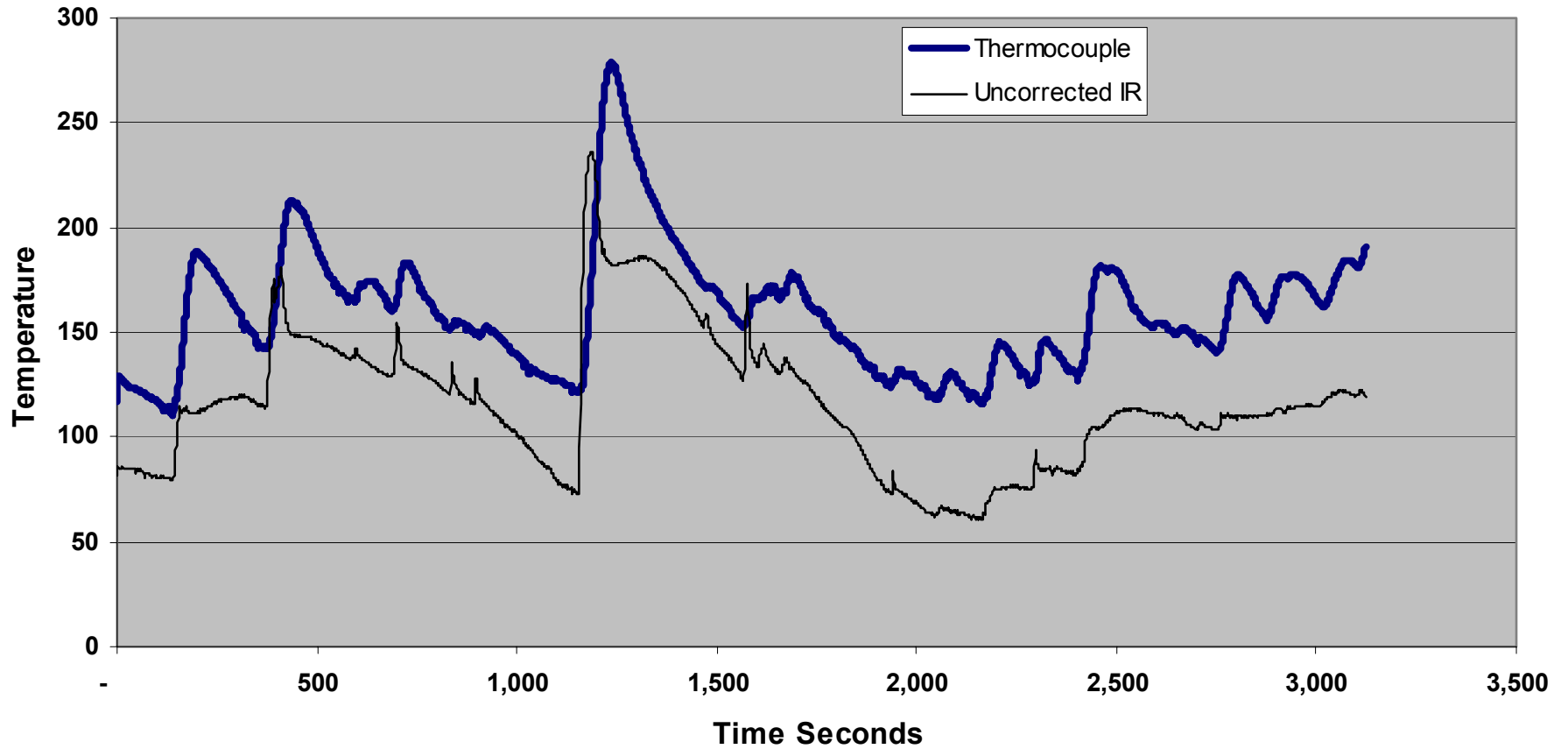

IR and Thermocouple Time History (Bias Compensation)

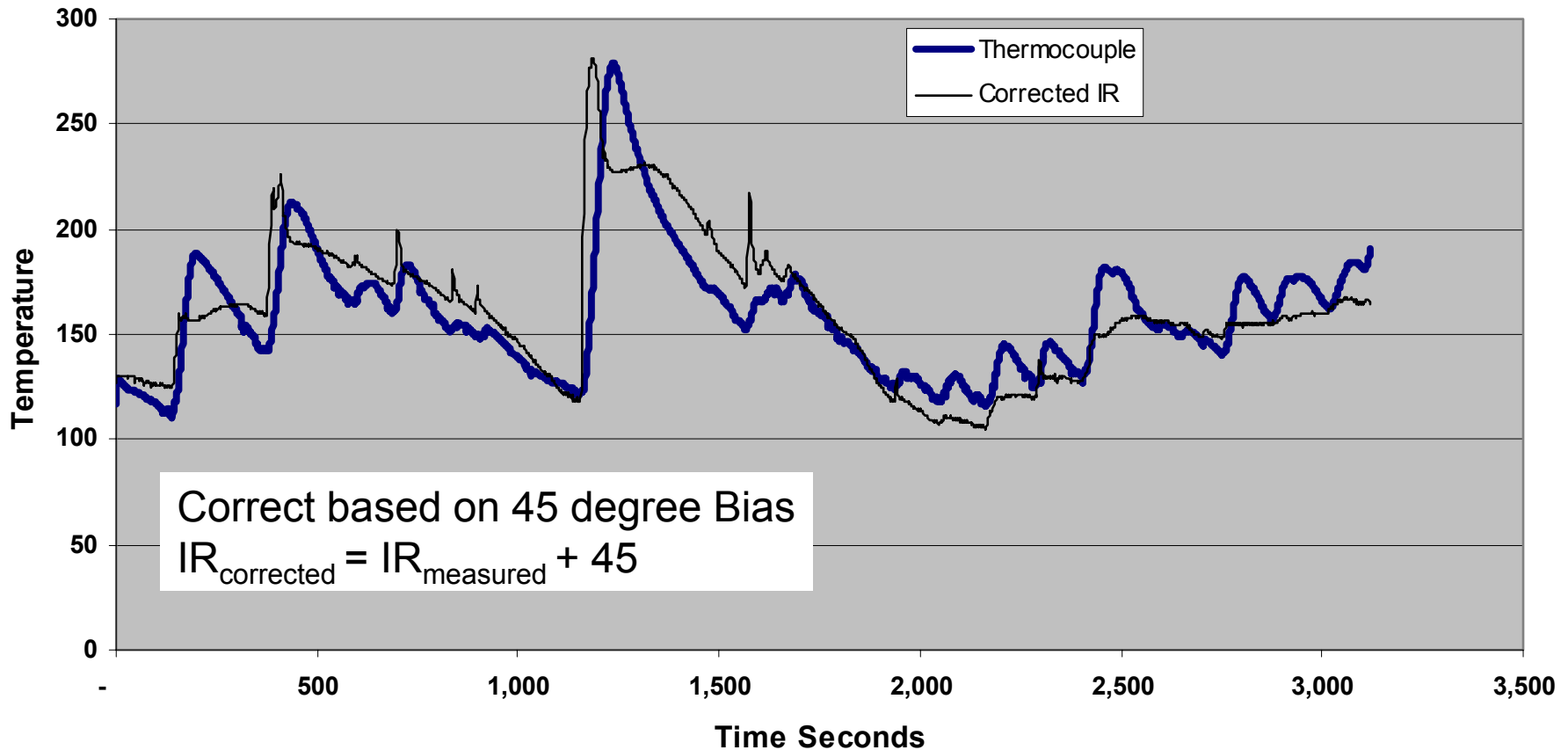

IR and Thermocouple Time History (Bias Compensation)

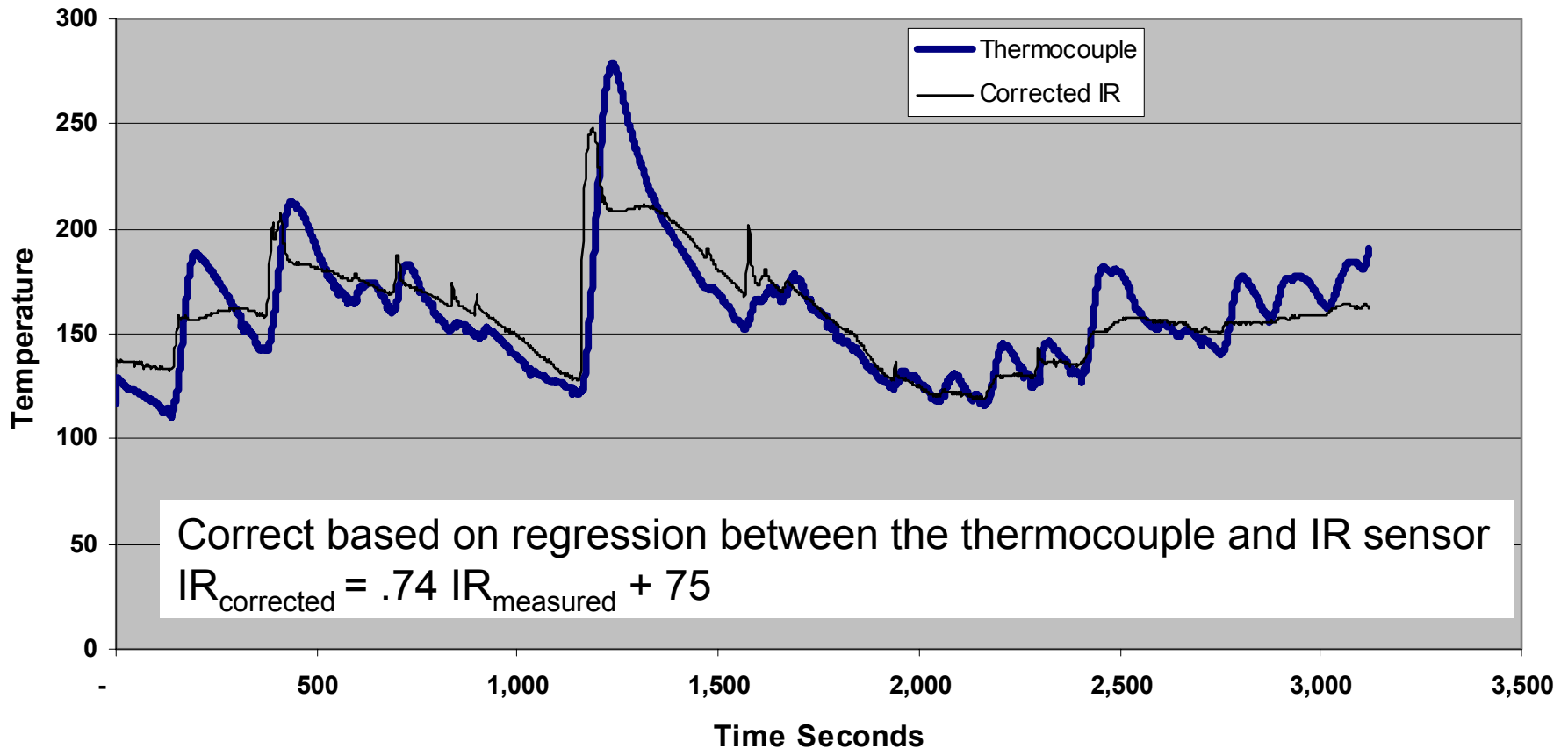

Comparison Of Thermocouple And IR Sensors During Braking

- The IR Sensor Responds Quickly To Application Of Brakes
- The Thermocouple Requires Significantly More Time
- Peak Temperature Response In Thermocouples Occurs 53 Seconds After Peak In IR Sensor
- See Next Plot

Difference Between IR And Thermocouple Response

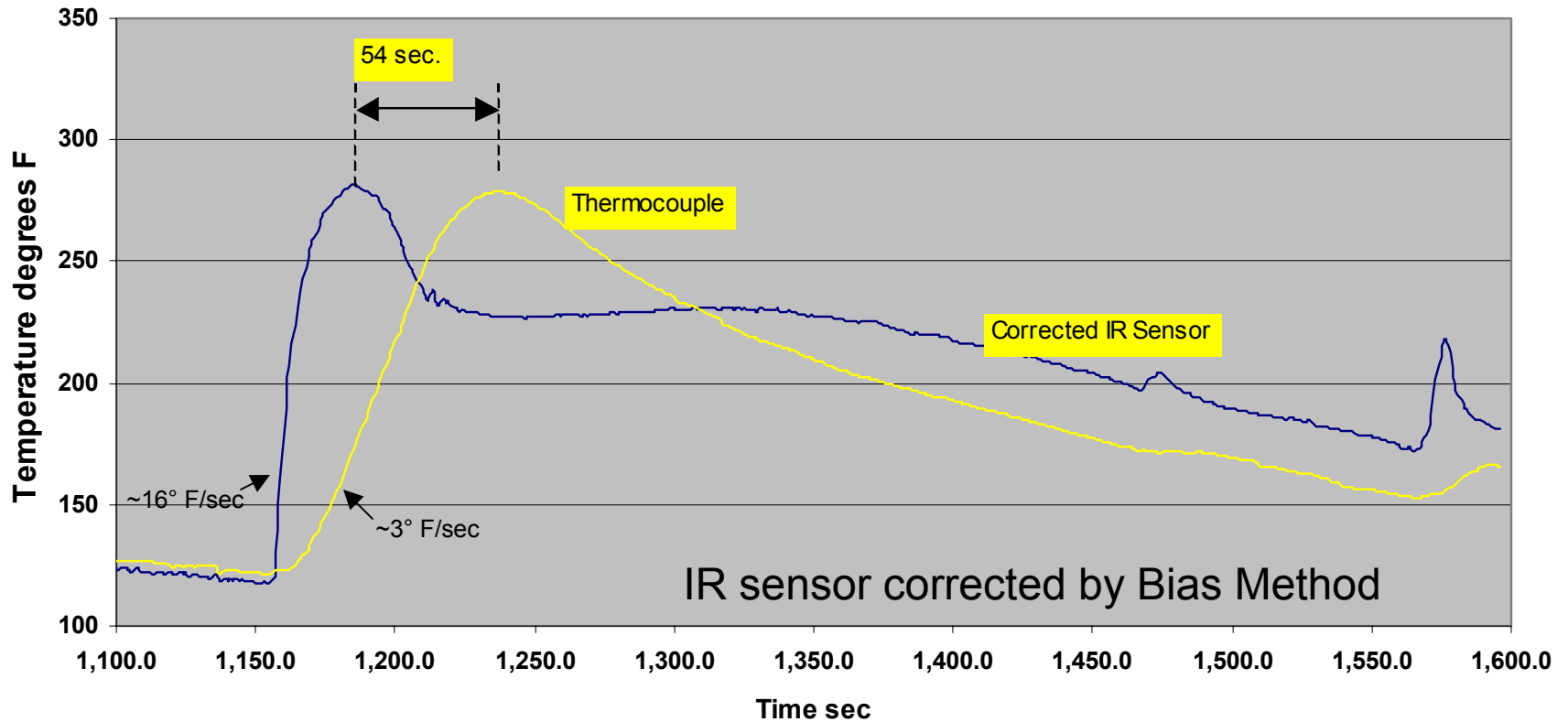

Testing On June 16-18

- The Thermocouples Were The Only Temperature Measurements On The Disc
- Temperature Measurements Were Made On Both The WABTEC/SAB-WABCO And Knorr Discs
- The Next Slide Shows The Recorded Temperatures On The Discs

Disc Temperature Measurements—Example 1

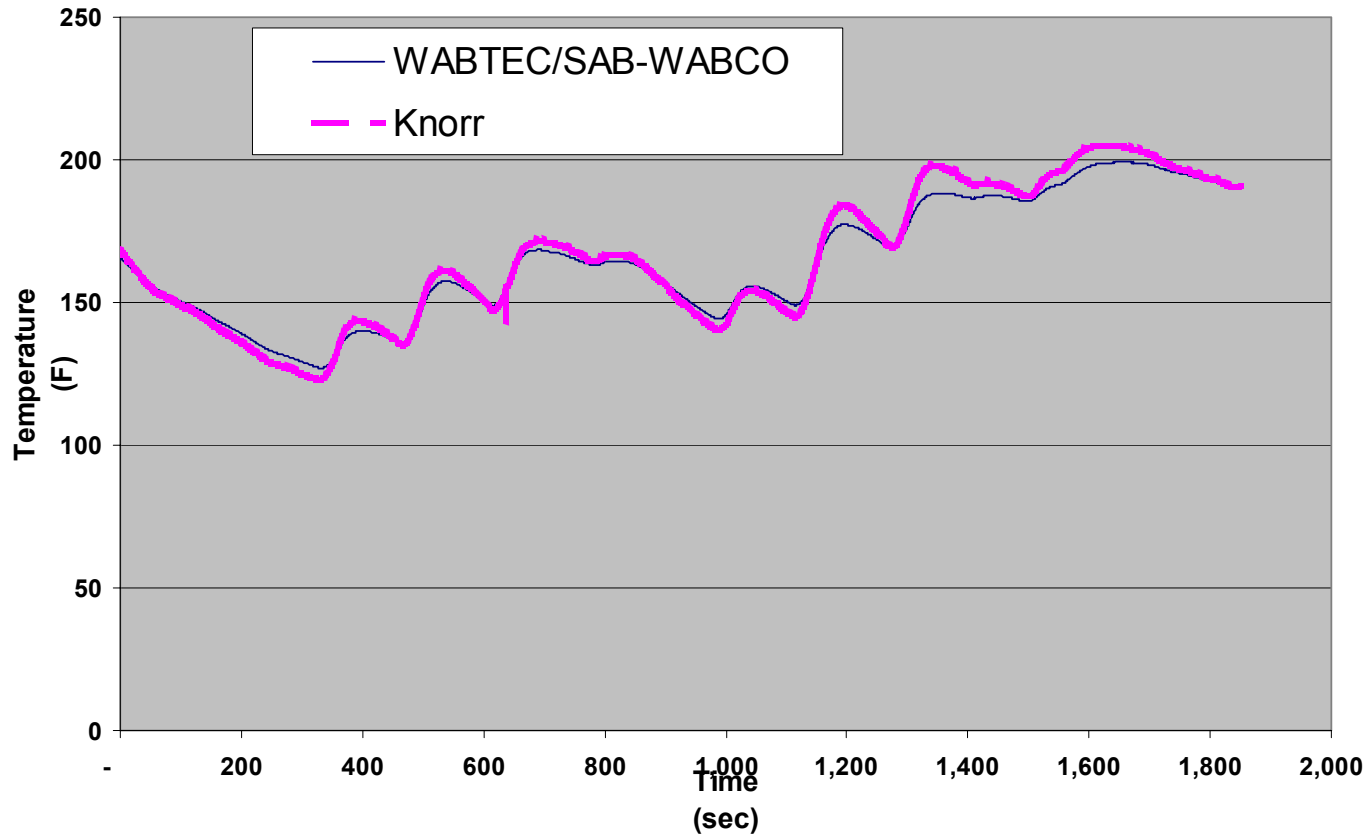

Disc Temperature Measurements—June 16, 2005— File 061605_18.AB3

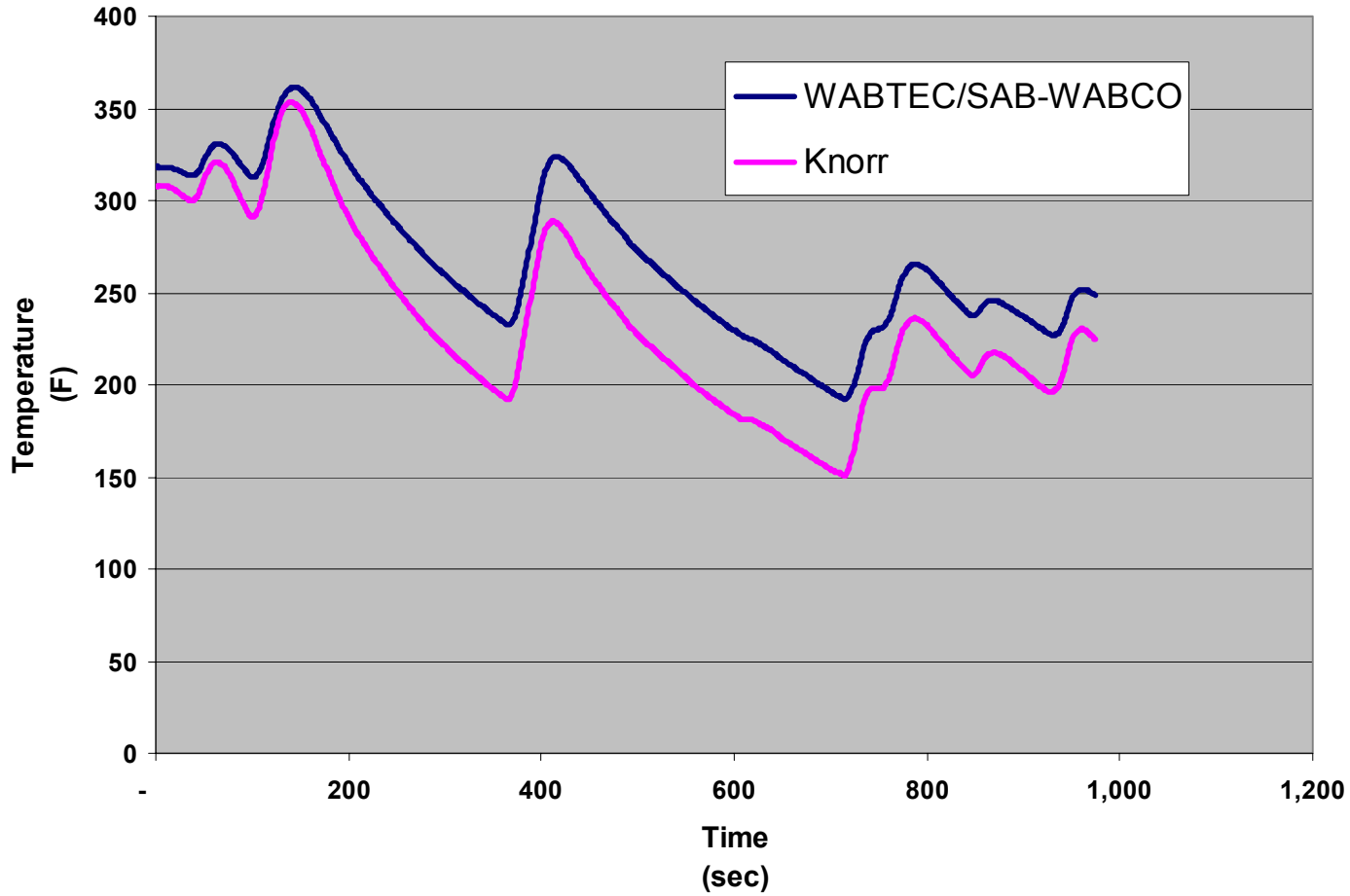

Observation

- The Discs Show Similar Temperature Profiles During Testing
- The Knorr Disc Heats Up And Cools Down Just Slightly Faster Than The WABTEC/SAB-WABCO Disc, Both Around 3 °F/Second
- Both Discs Reached A Temperature Of 360 °F, The Highest Seen During Testing

Spoke Strains and Temperature

Spoke Mean Strain

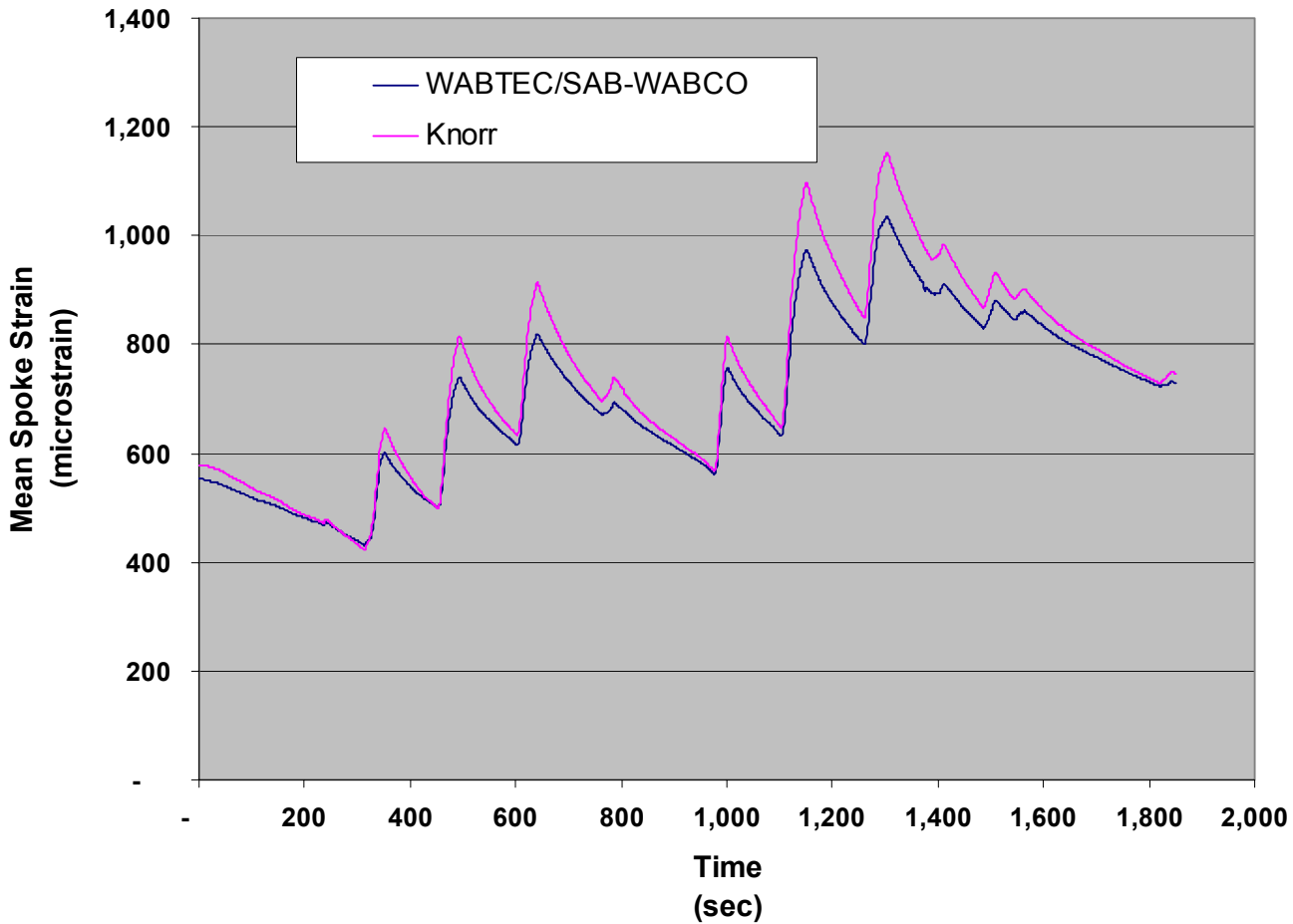

Mean Spoke Strain Measurements—June 16, 2005— File 061605_18.AB3

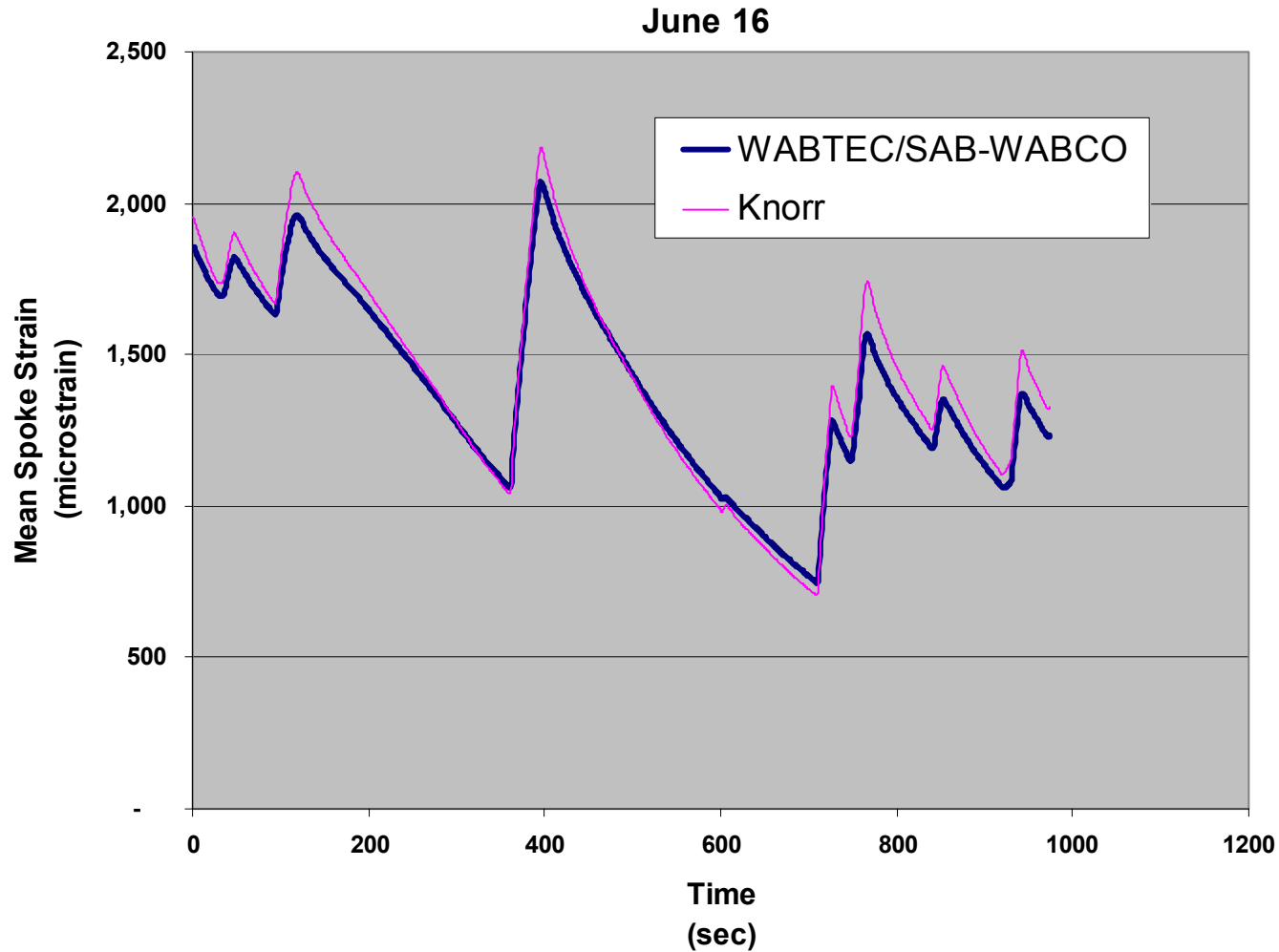

Observations

- Both Discs Show Similar Mean Strain Profiles
- The Knorr Disc Shows 3% To 5% More Mean Strain
- Maximum Mean Strains Of 2200 Microstrain Were Observed For The Knorr Disc
- Maximum Mean Strains Of 2100 Microstrain Were Observed For The WABTEC/SAB-WABCO Disc

Spoke Mean Strain Versus Temperature Of Disc Friction Plate

- Temperature Is Measured With Thermocouple Mounted On Back Side Of Disc Near The Outer Edge Of The Friction Ring
- Strains Are The Average Of Gage Pairs

Strain Estimates Based on Temperature

- Analysis conducted to estimate the amount of spoke tensile strain per friction plate temperature increase
- This approach used temperature and strain measurements at the beginning of each braking event over a full testing day
- While the new values are lower than the initial estimates, the relationship of the Knorr and WABTEC/SAB-WABCO discs remained the same
- The Knorr disc shows about 10% more strain than the WABTEC/SAB-WABCO disc

Spoke Strain/Disc Temperature

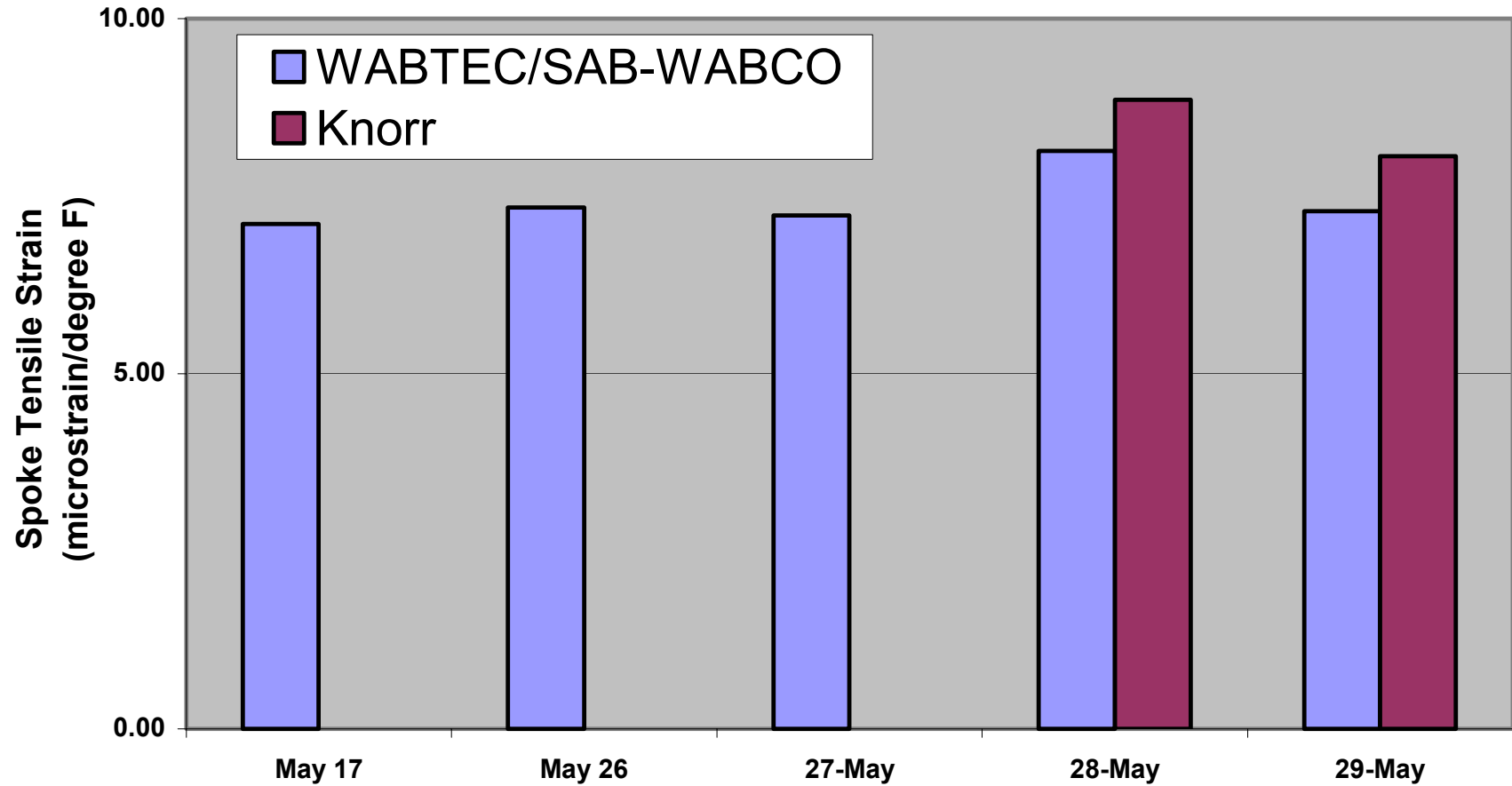
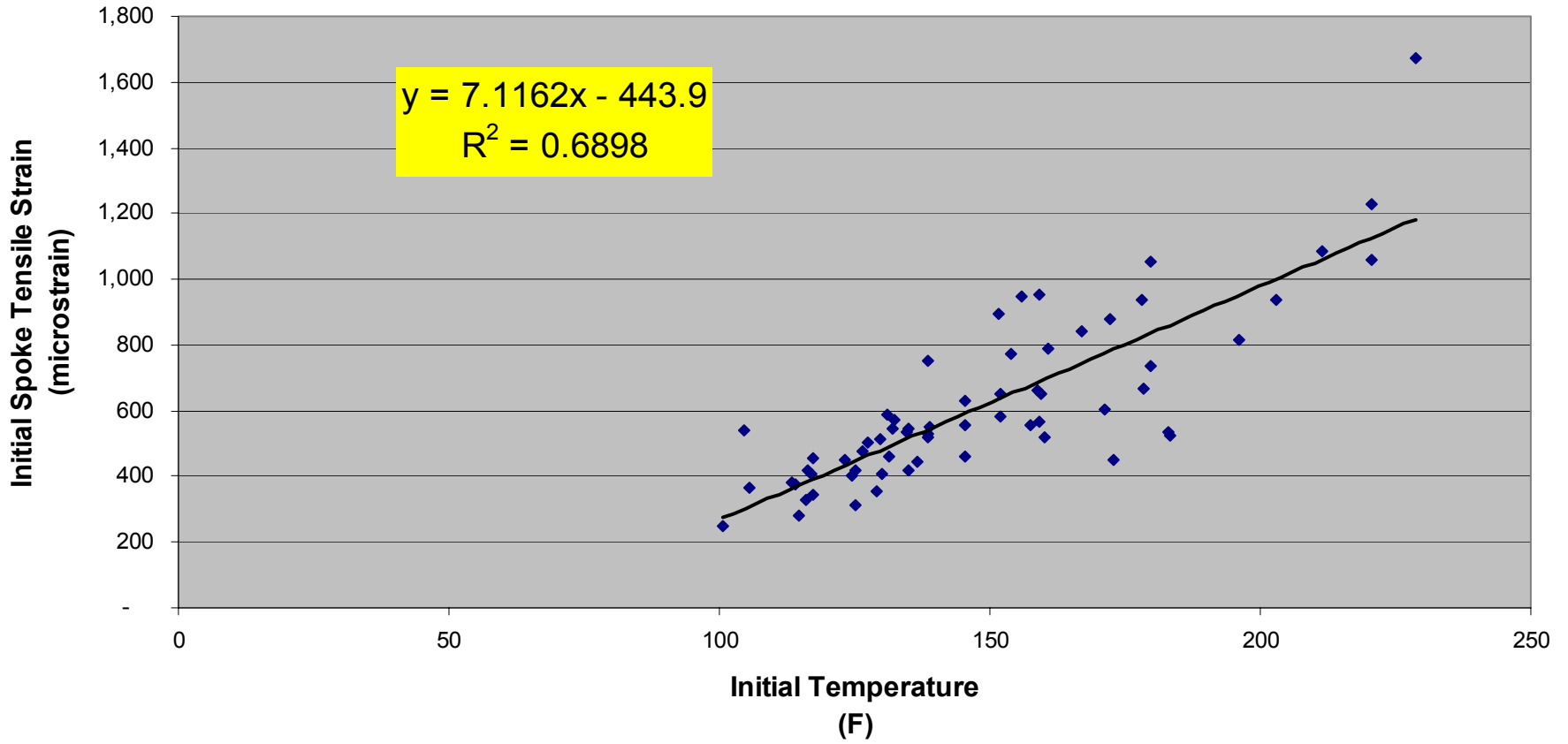

Table I.2. Summary of Strain Estimates Per Degree in Temperature

Spoke 6 Tensile Strain Microstrain/°F		
	WABTEC/SAB -WABCO	Knorr
May 17	7.11	N/A
May 26	7.34	N/A
May 27	7.23	N/A
June 17	8.14	8.86
June 18	7.29	8.06

May 17 Center WABTEC/SAB-WABCO Disc Spoke 6



May 26 Center WABTEC/SAB-WABCO Disc Spoke 6

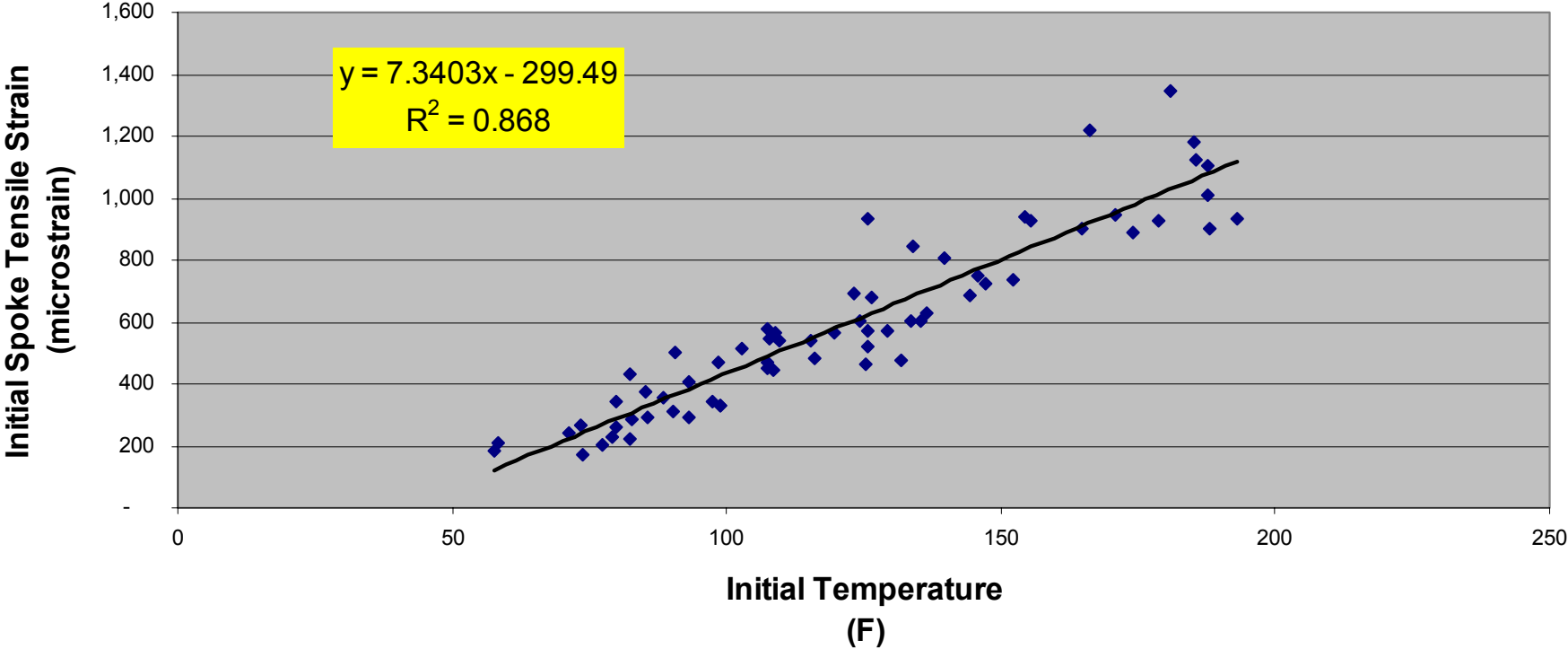

May 27 Center WABTEC/SAB-WABCO Disc Spoke 6

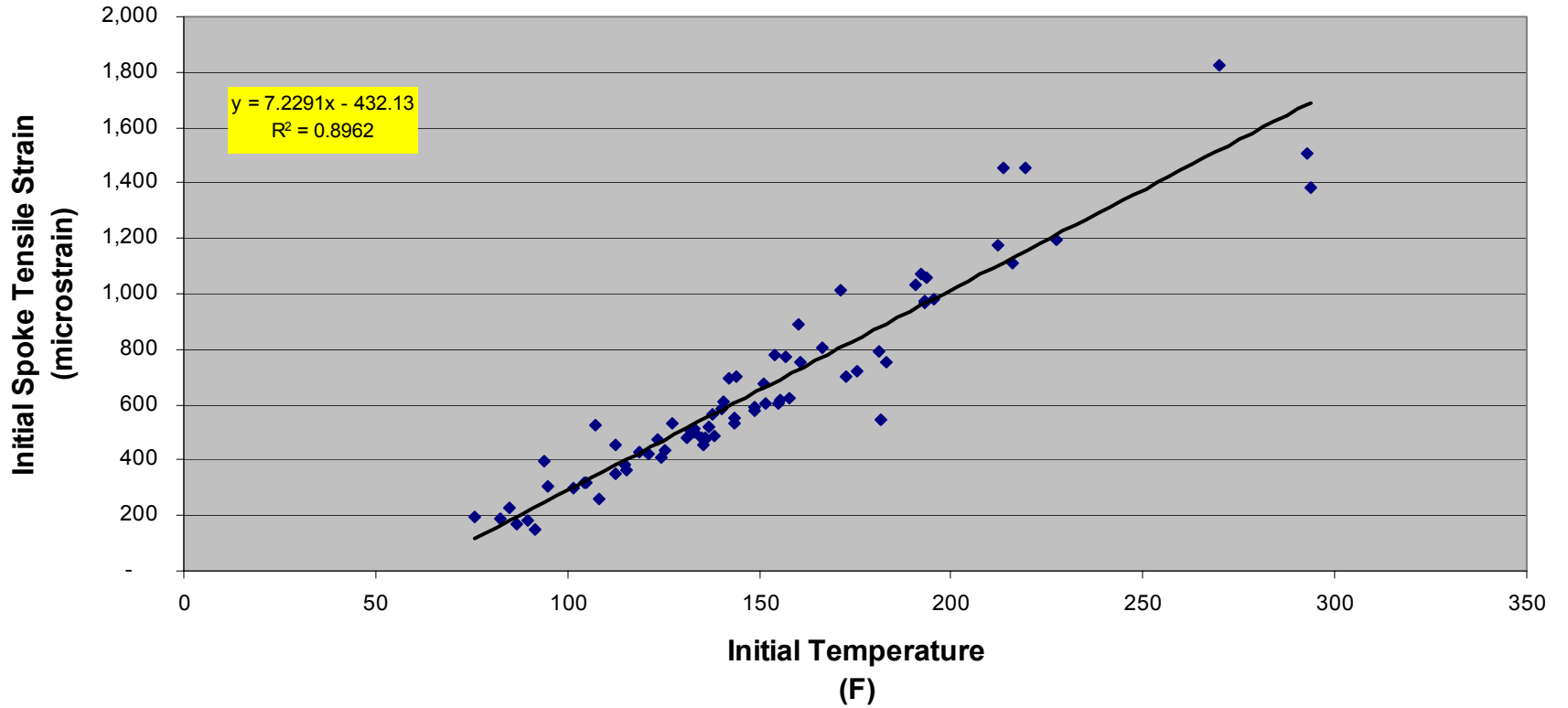

June 17 Center WABTEC/SAB-WABCO Disc Spoke 6

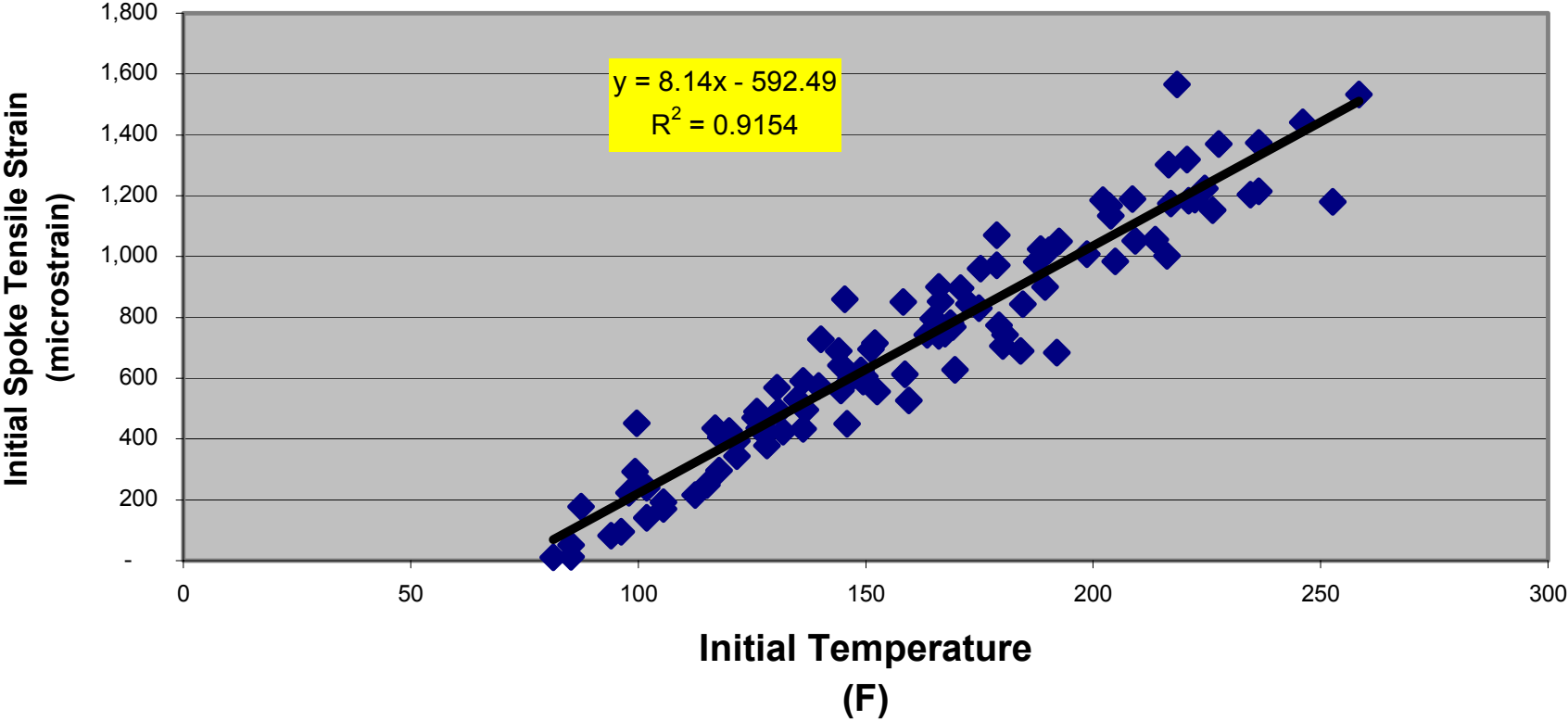

June 17 Center Knorr Disc Spoke 6

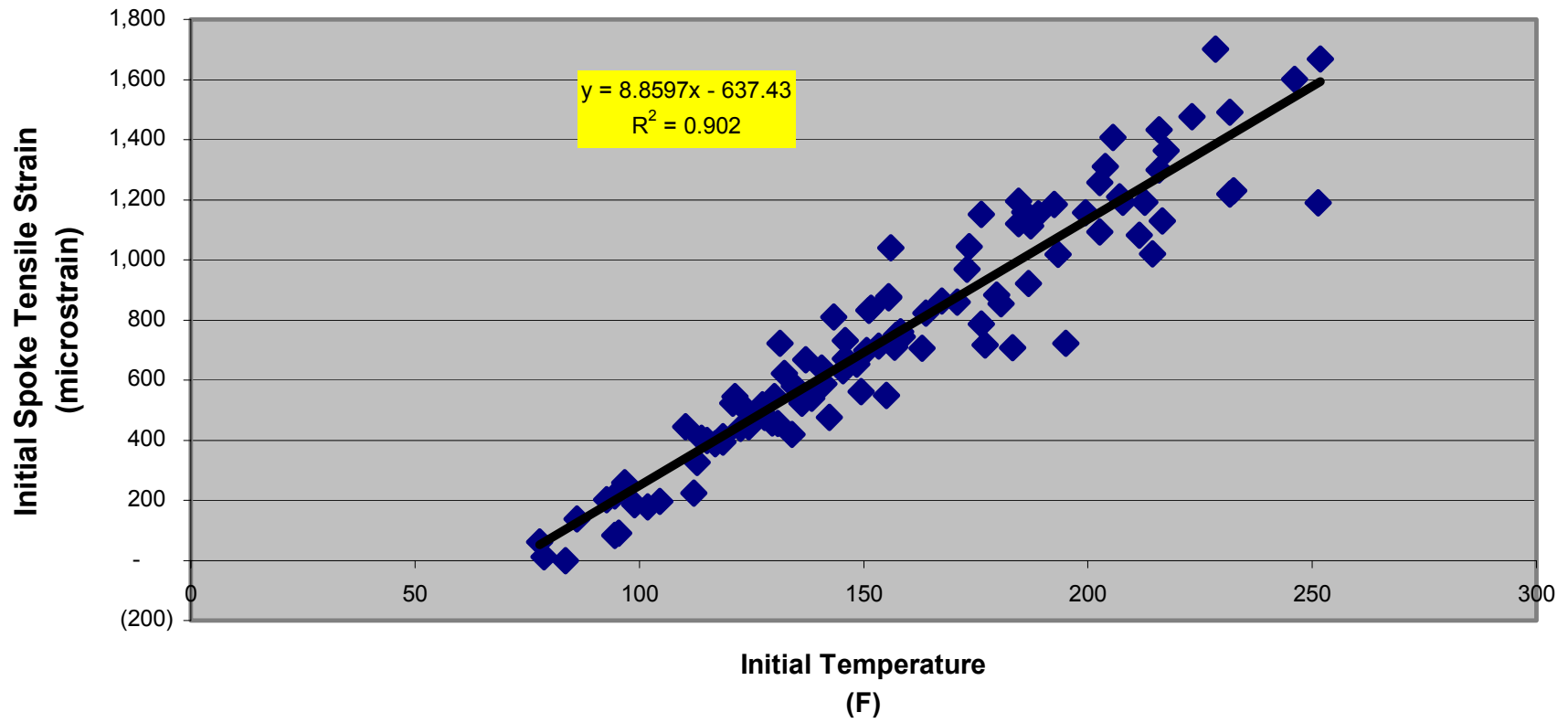

Axle 1-WABTEC/SAB-WABCO Disc
June 18, 2005

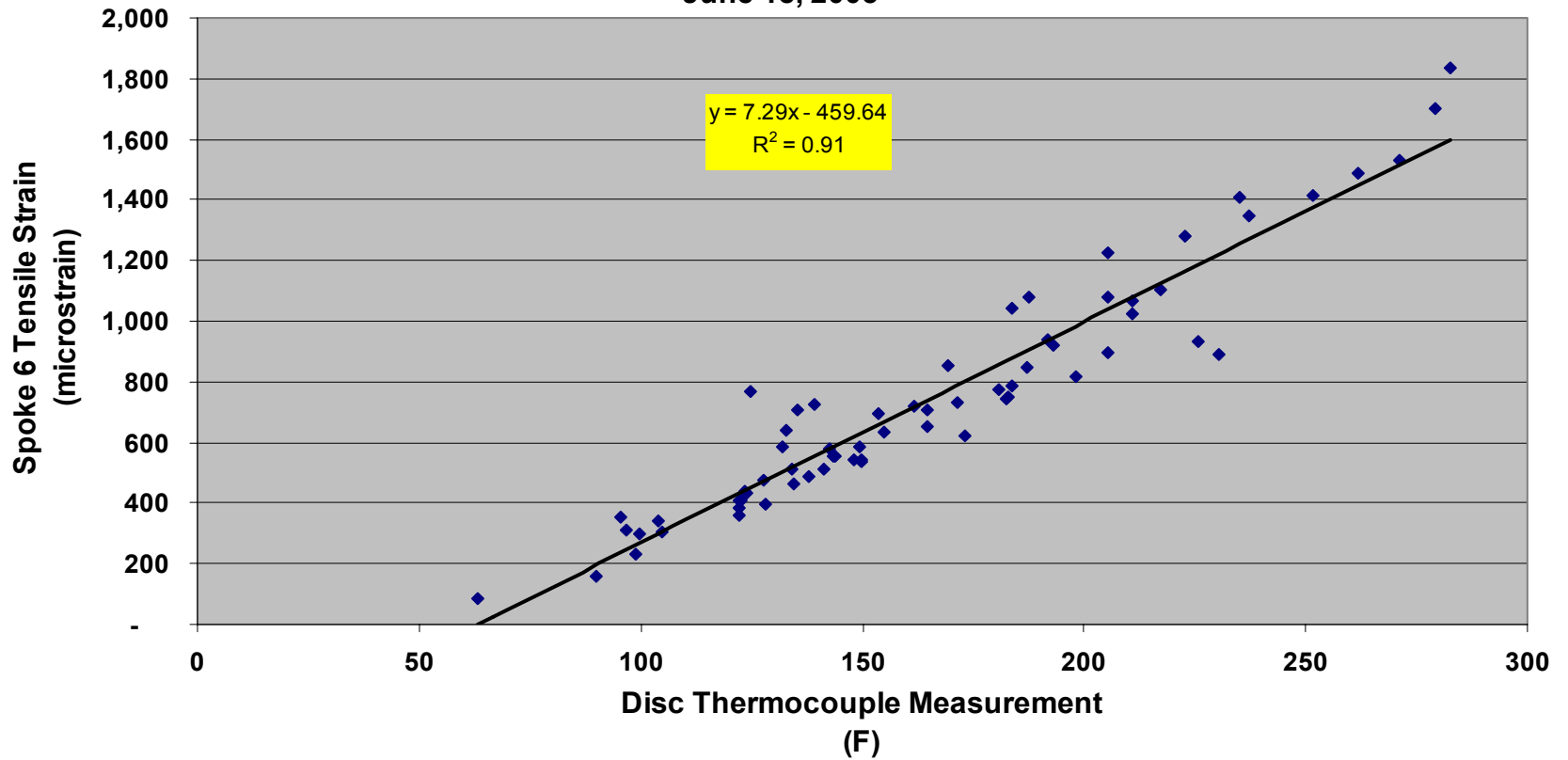

Axle 2-Center Knorr Disc
June 18, 2005

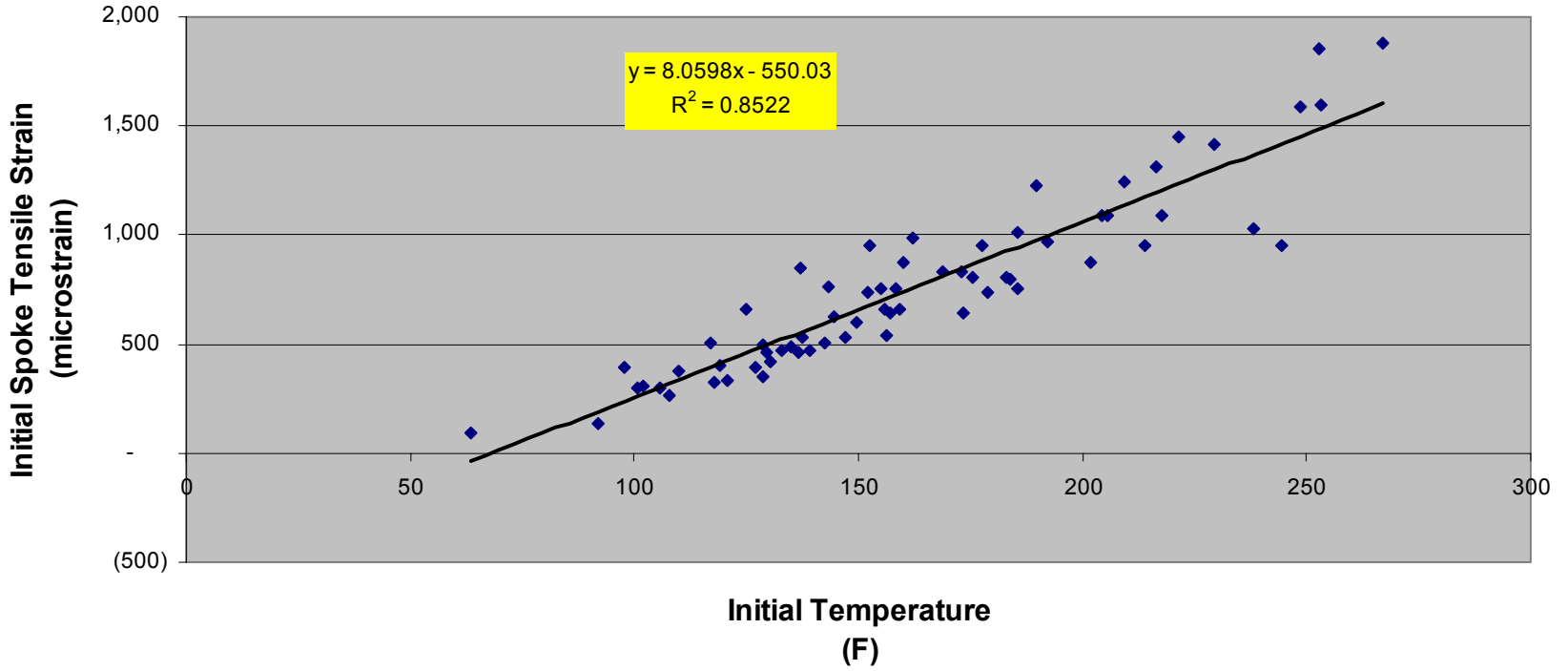

Heating and Cooling of Discs

Heating Of Discs

- Based On A Limited Number Of Braking Sequences, It Was Observed That The Knorr Disc Heated Up More Than The WABTEC/SAB-WABCO Disc During Braking
- A Methodology To Quantify This Difference Was Developed To Include All Braking Sequence Days For Which Temperature Data Was Observed

Temperature Rise

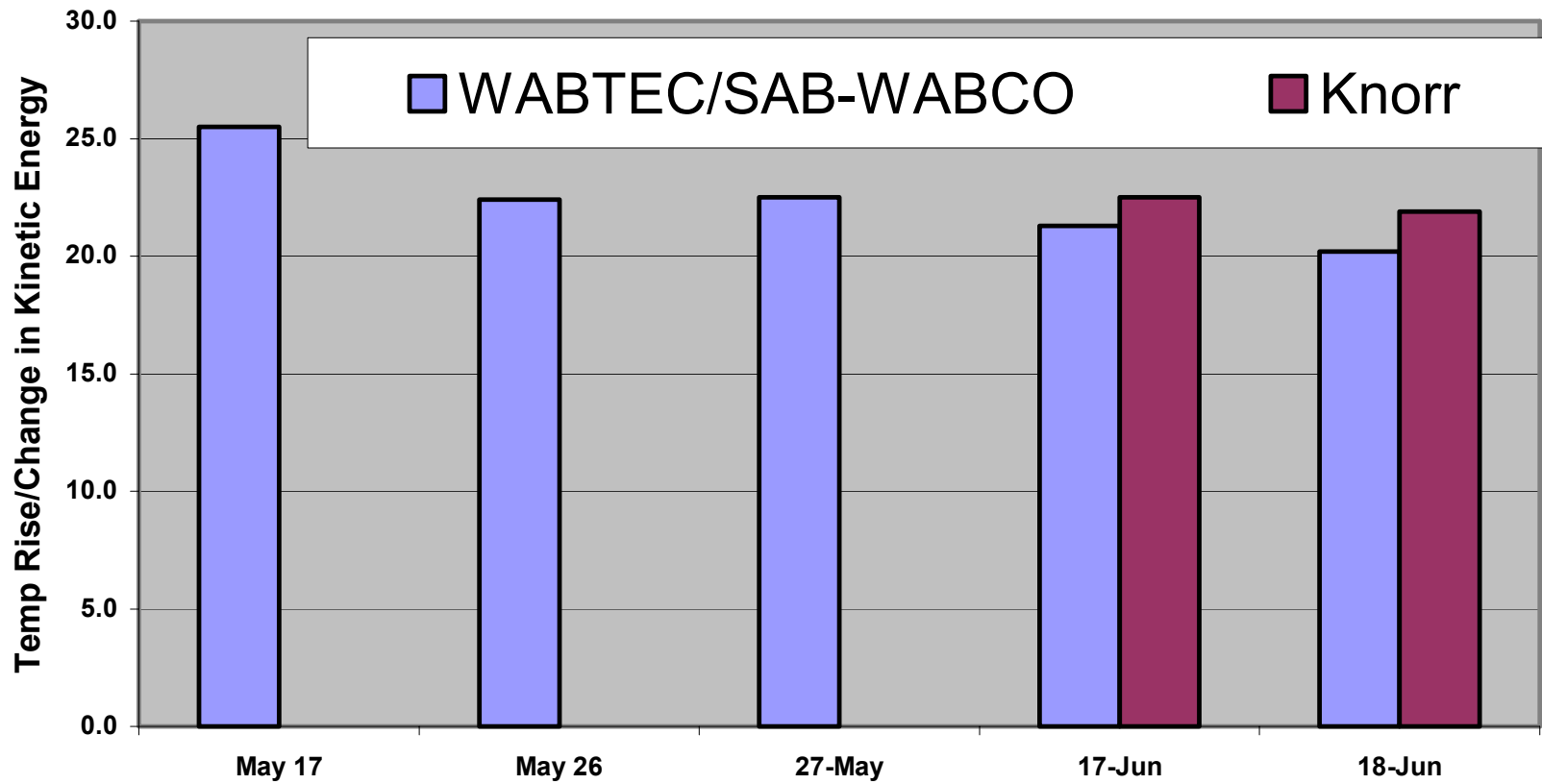

Disc Temperature Rise Due To Braking

Kinetic Energy
Dissipated
Per Disc

Foot Pounds

$$\frac{1}{2}M(V_i^2 - V_f^2)$$

M = Mass of Vehicle/12

V_i = Initial Speed of Vehicle

V_f = Final Speed of Vehicle

Vehicle Weight = 139,000 lbs
12 Disc Per Vehicle

Heat
Produced

BTU

1,281 BTU = 1,000,00 ft-lbs

Thermal
Mass

Pounds

For Steel:
Specific Heat
0.12 BTU/(lbm-F)

Temperature
Rise

Degrees F

Temperature Rise = (1,281/.12 Thermal Mass) Delta KE
 Temperature Rise = (10,675/Thermal Mass) Delta KE

Temperature Build-Up During Braking

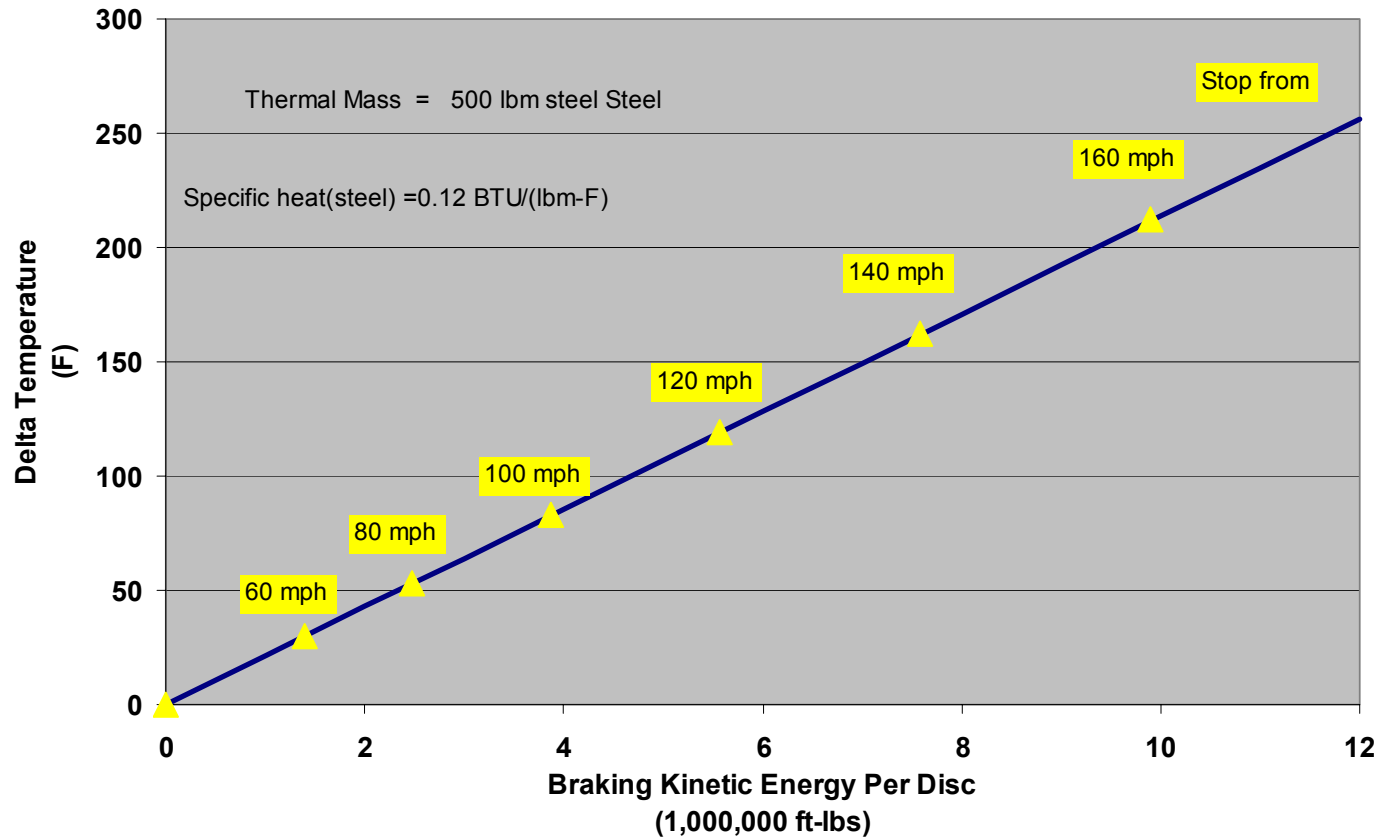
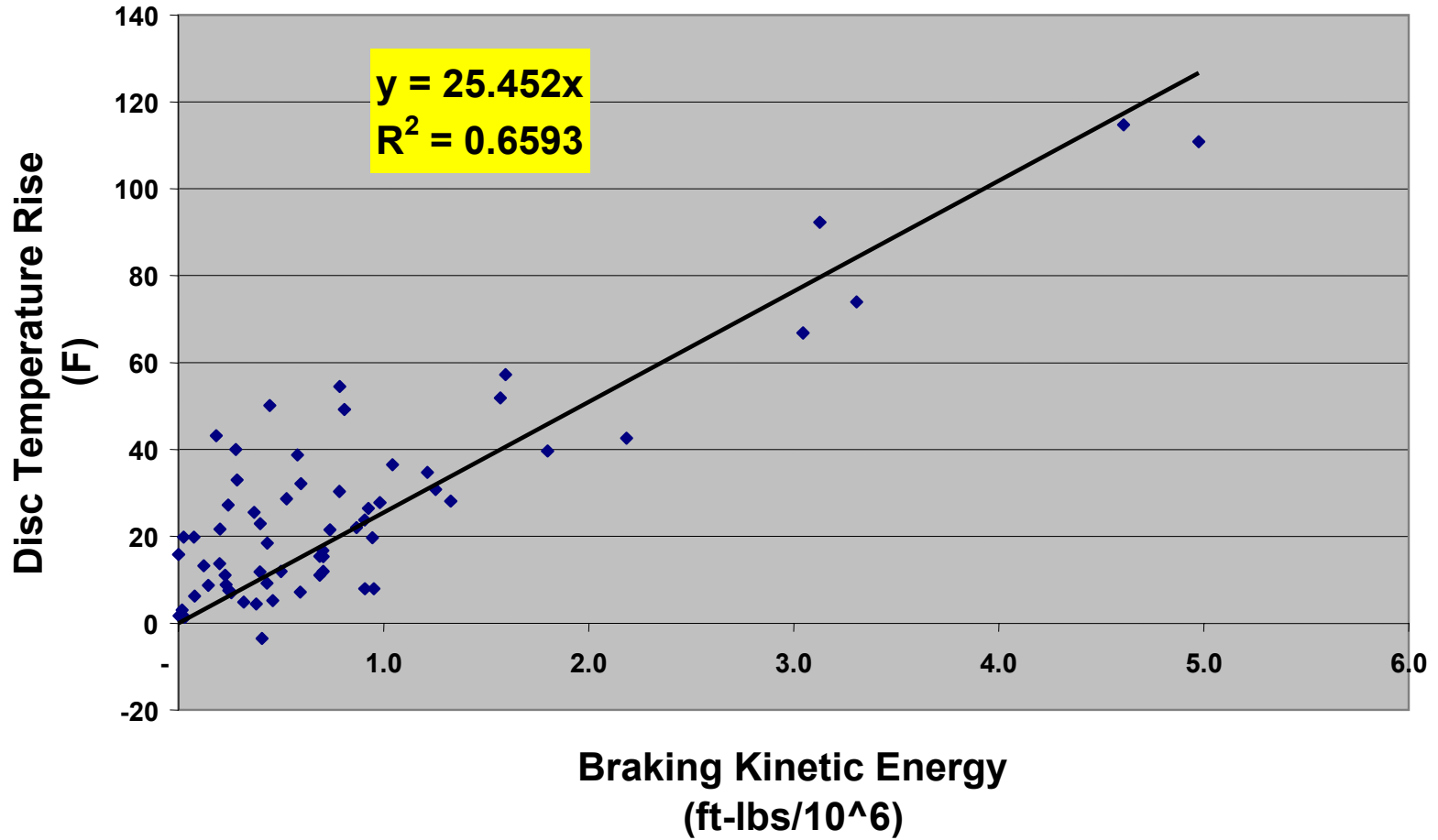

Table I.3. Summary, Disc Temperature Rise for Change in Kinetic Energy Table

	Disc Temperature Rise for Change in Kinetic Energy TC_{ke}	
	WABTEC/SAB -WABCO	Knorr
May 17	25.5	N/A
May 26	22.4	N/A
May 27	22.5	N/A
June 17	21.3	22.5
June 18	20.2	21.9

CT_{ke}–May 17–Center WABTEC/SAB-WABCO Disc



CT_{ke}–May 26–Center WABTEC/SAB-WABCO Disc

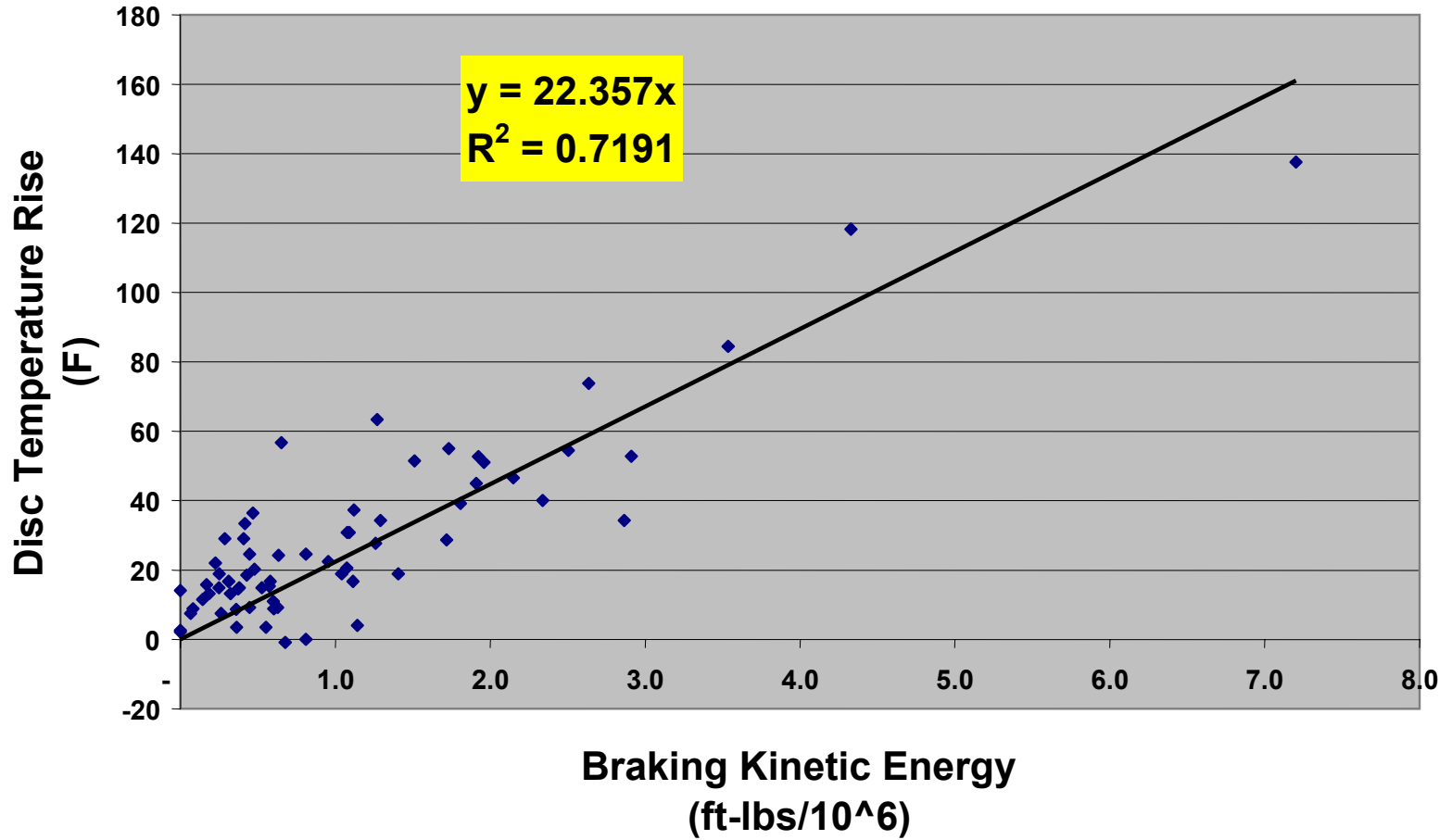

CT_{ke}-June 17-Center WABTEC/SAB-WABCO Disc

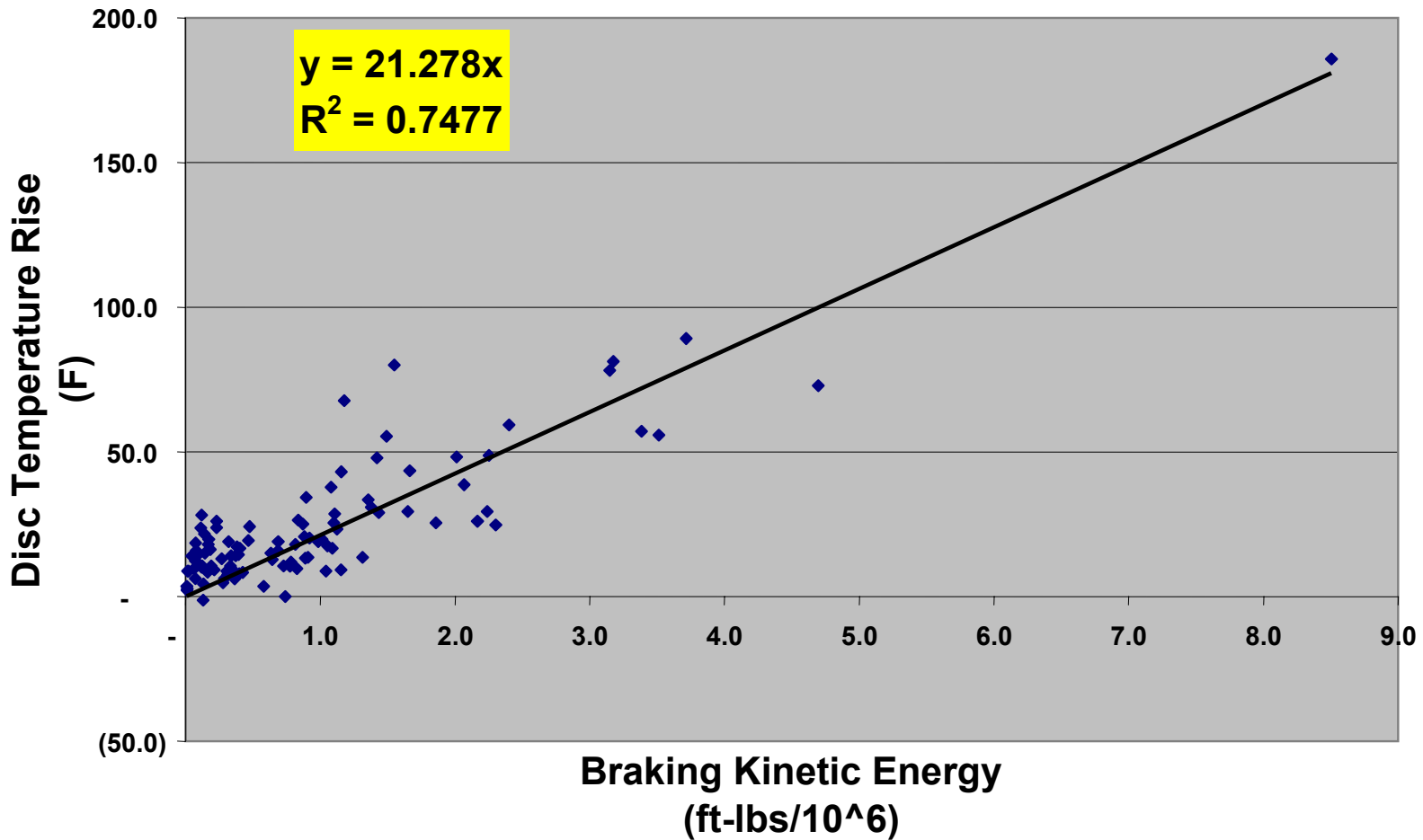

CT_{ke}-June17-Center Knorr Disc

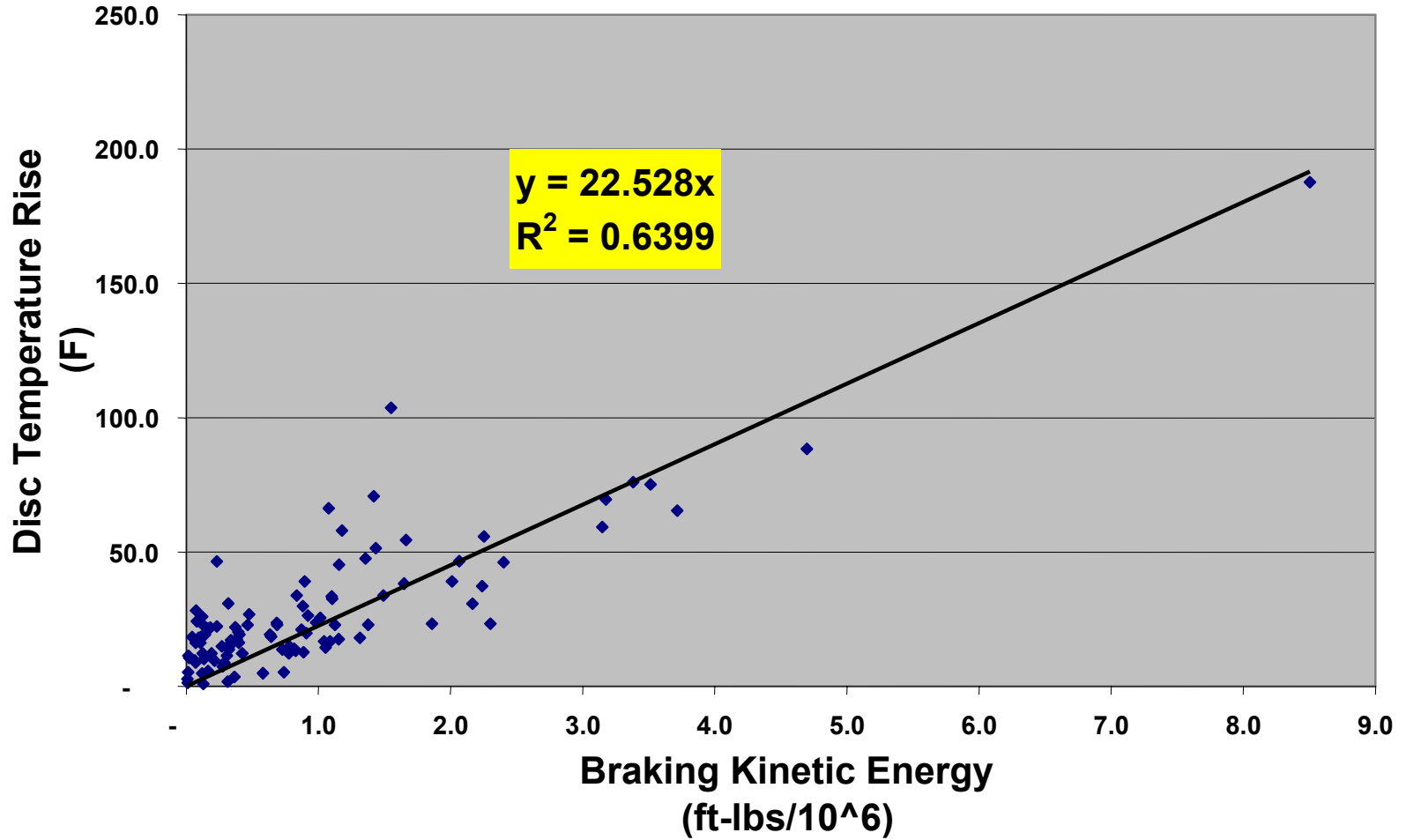

CT_{ke}–June 18–Center WABTEC/SAB-WABCO Disc

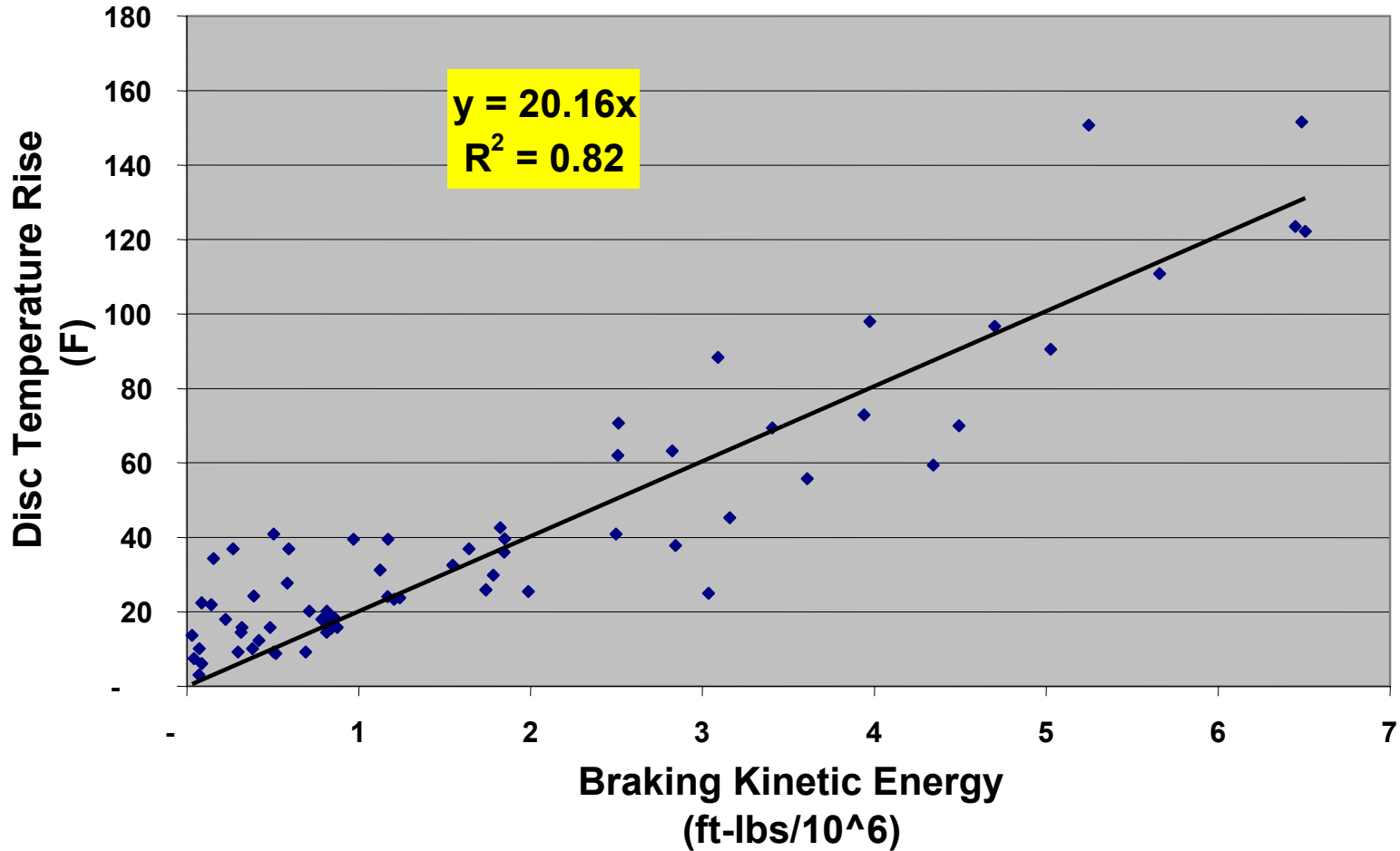

CT_{ke}–June 18–Center Knorr Disc

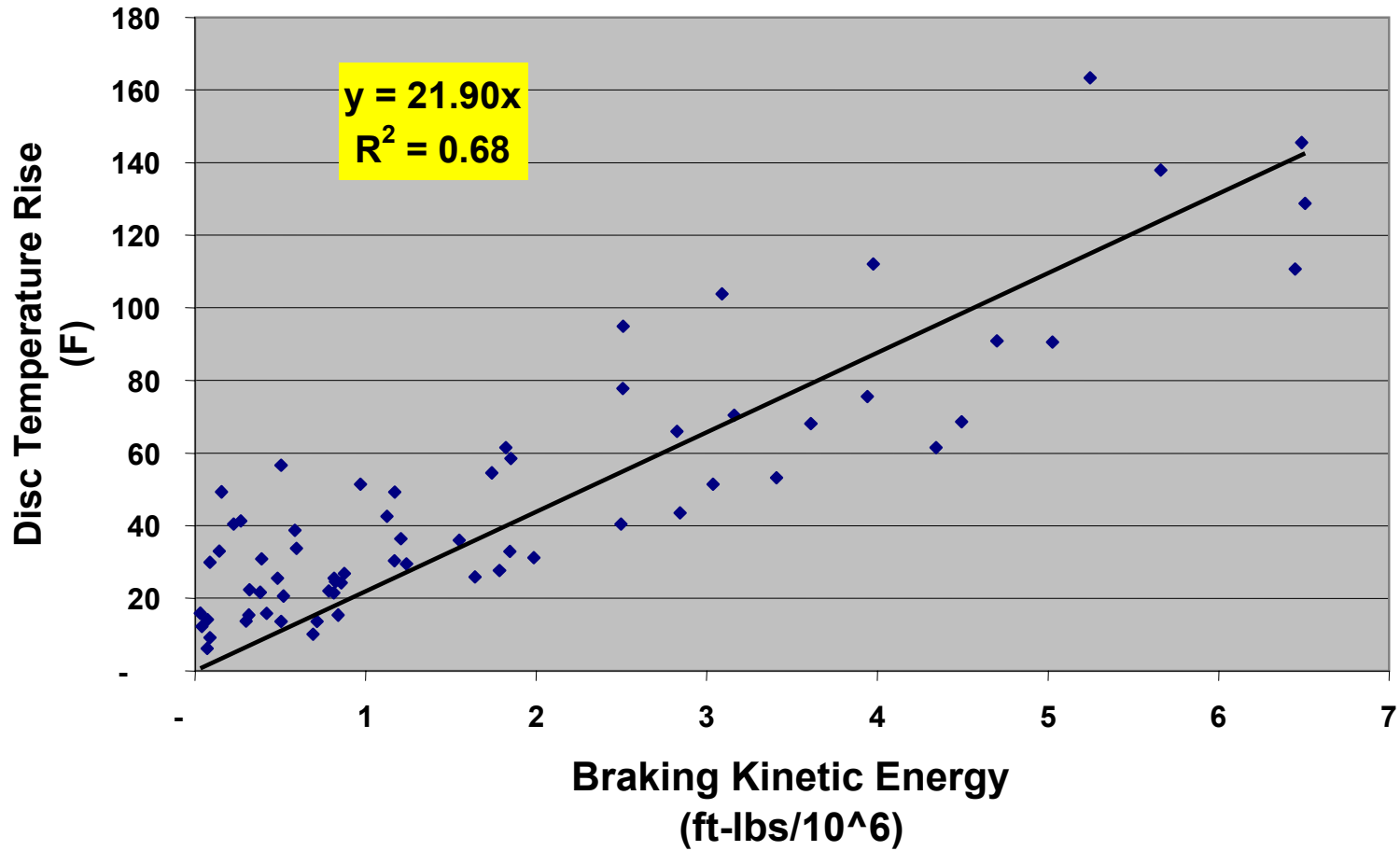

Cooling Of Discs

- Analysis Conducted To Address The Time Constants For The WABTEC/SAB-WABCO And Knorr Discs Under The Same Operational Conditions
- The Knorr Disc Cools Down Faster Than The WABTEC/SAB-WABCO Disc, While The Knorr Disc Heats Up Faster During Braking Cycles

Temperature Profile of WABTEC/SAB-WABCO and Knorr Brake Discs During Shakedown Run, File 061605_18.AB3-June 16, 2005

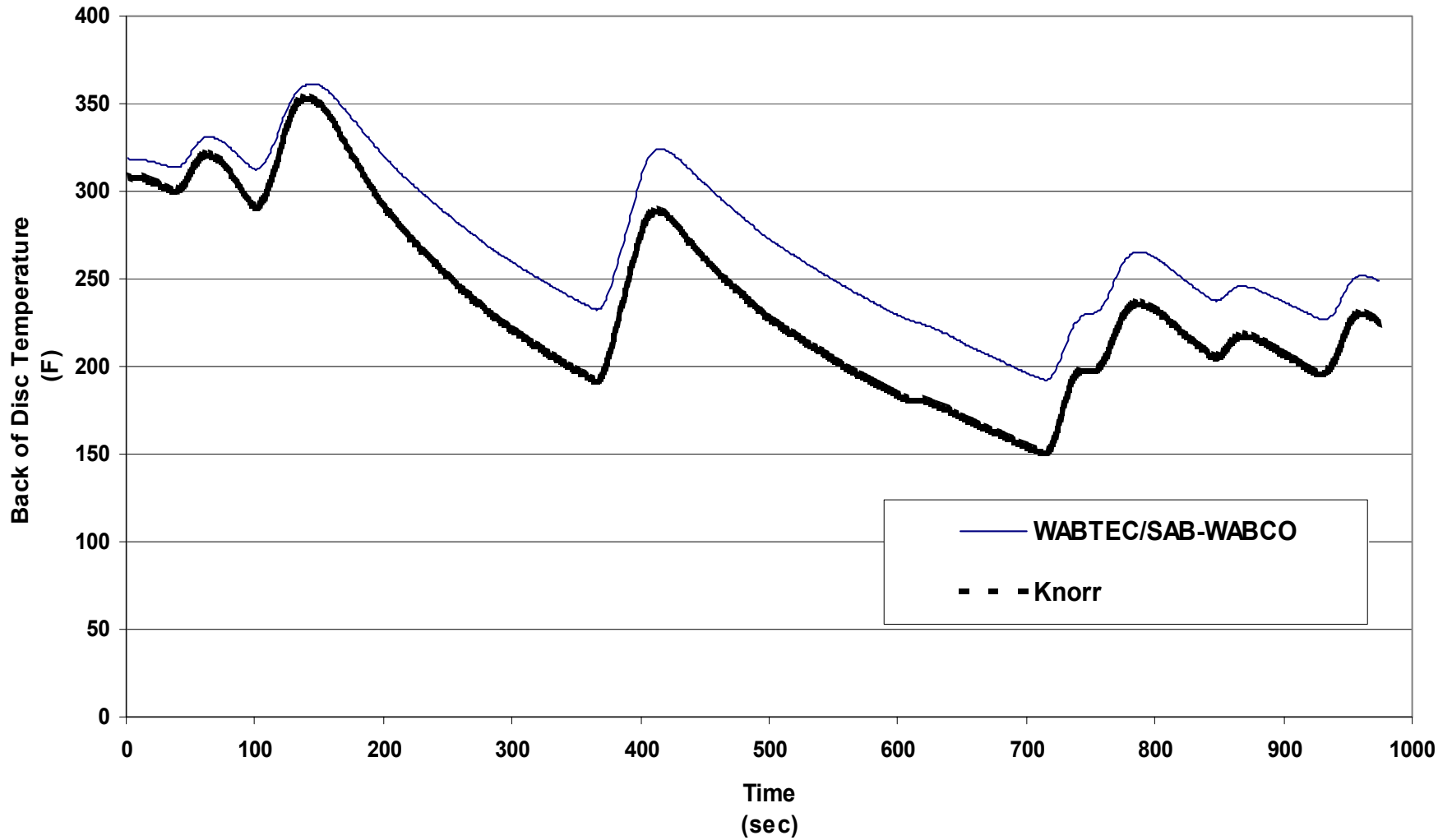

Table I.4. Thermal Time Constants

Event	Observation Period	Initial Temperature		Time Constant		Ratio
		WABTEC/ SAB-WABCO	Knorr	WABTEC/SAB- WABCO	Knorr	
1	221	361	352	355	251	71%
2	303	324	289	400	299	75%

Average **377** **275** **73%**

Time Constant (minutes) **6.3** **4.6**

**Back of Disc Temperature, WABTEC/SAB-WABCO Disc
June 16-File 061605_18**

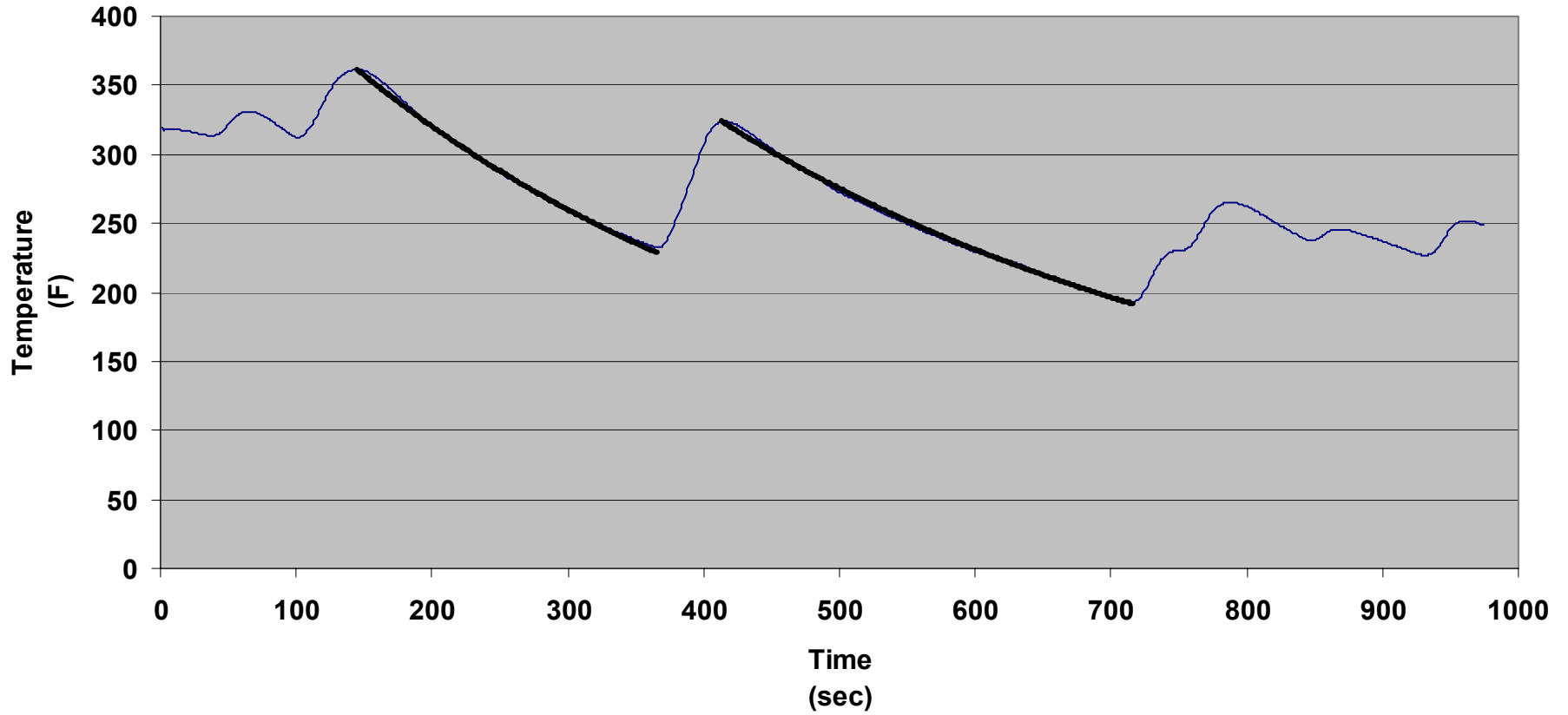

**Back of Disc Temperature, Knorr Disc
June 16-File 061605_18**

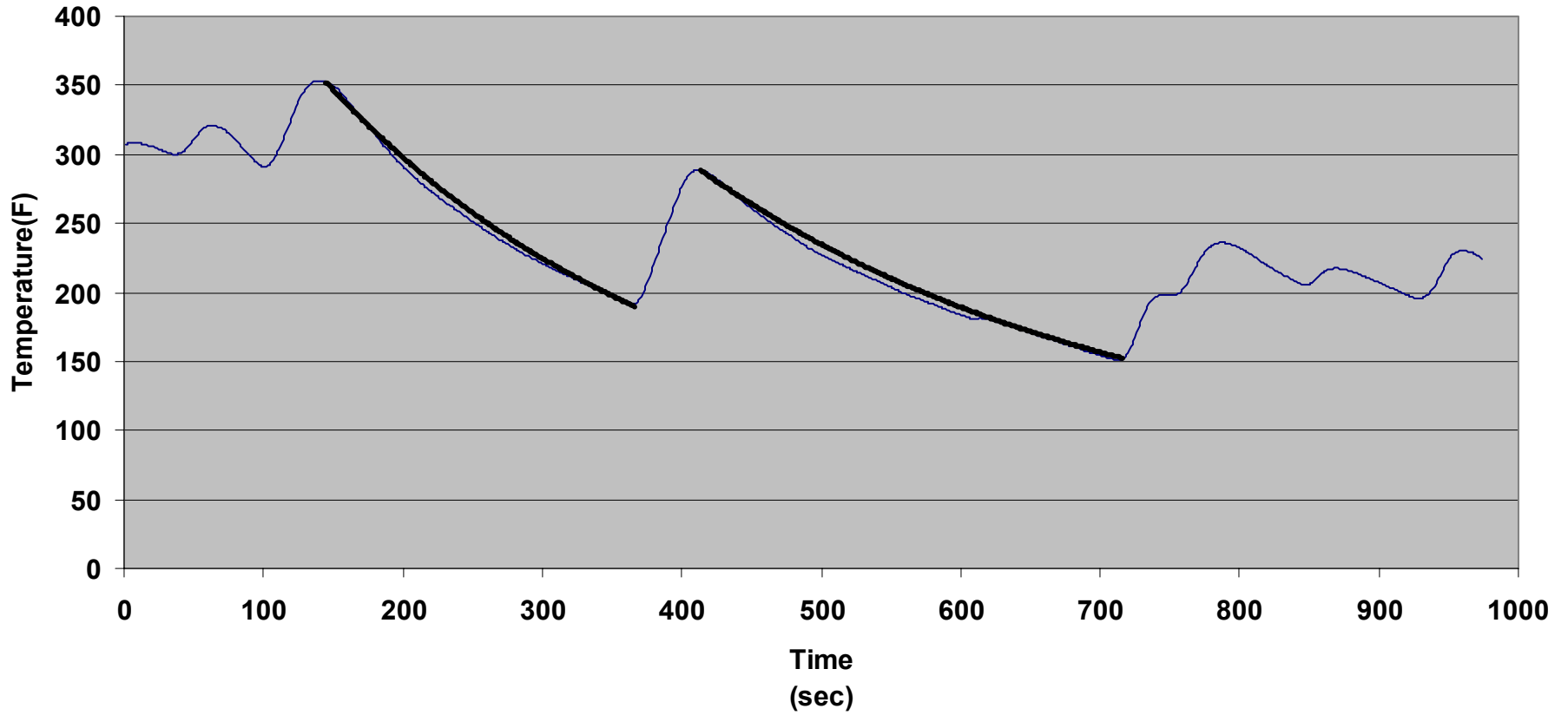
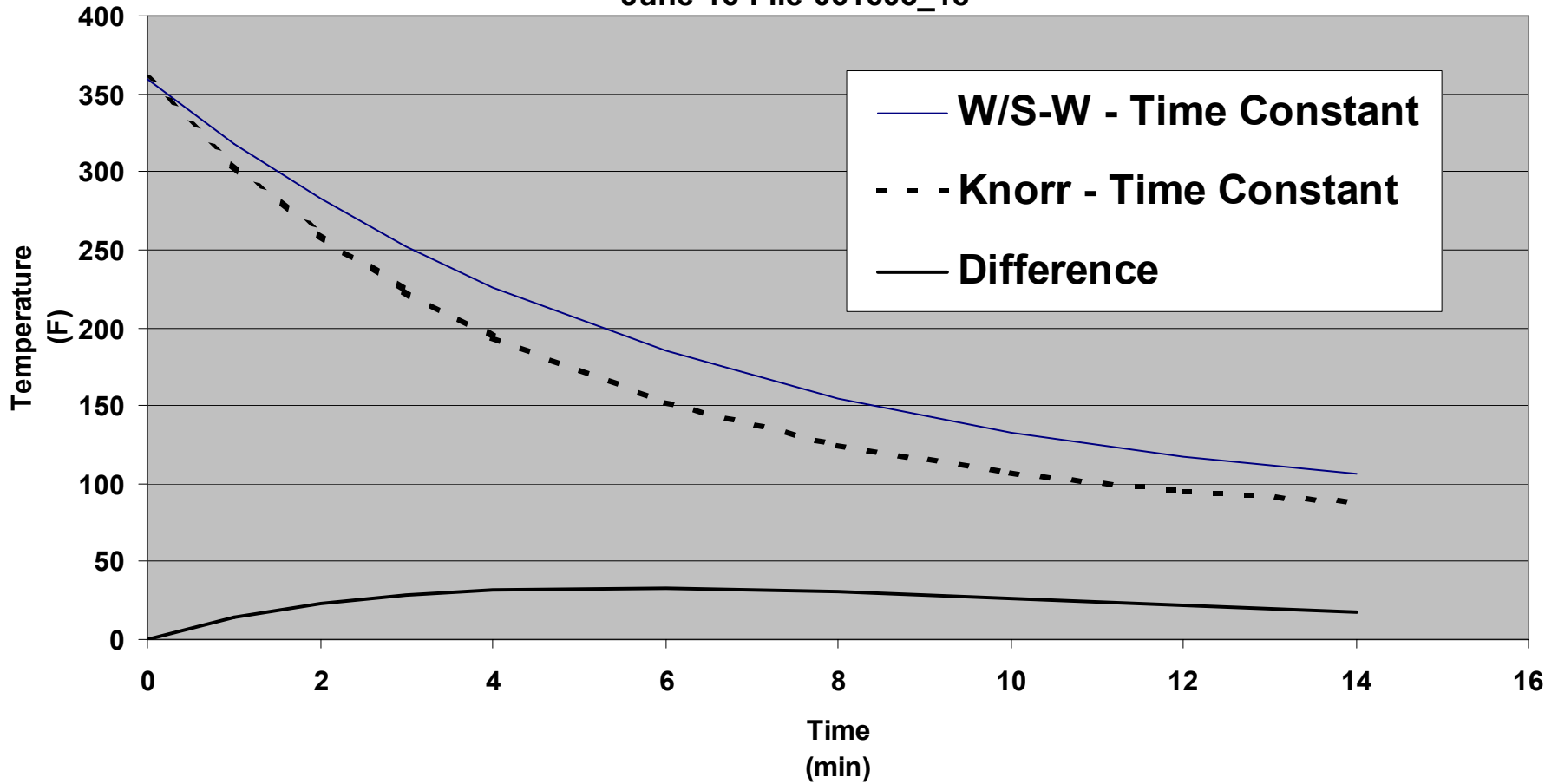
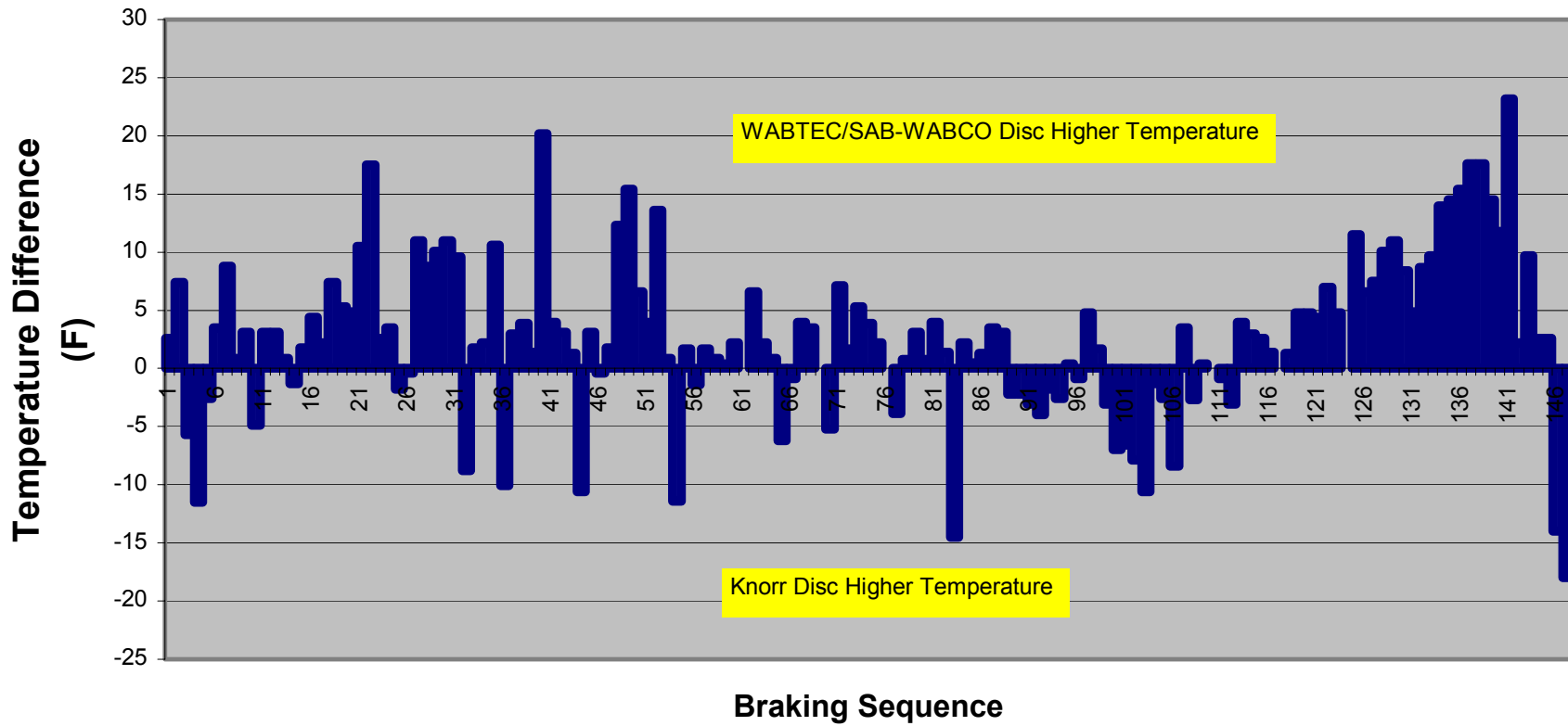

Illustration of Time Constants
June 16-File 061605_18



Temperature Differences After Braking Events - June 17, 2005



Appendix J. Laboratory Testing

<u>Part</u>	<u>Page</u>
Part A: Resolver Synchronization and Spreader Bar Test	J-2–J-6
Part B: Residual Strains	J-7–J-38
Part C: Vibration Analysis	J-39–J-71

Part A: Resolver Synchronization and Spreader Bar Test

Resolver Synchronization

- Rotate axle in defined direction
- Record slip ring resolver sine wave output
- Record spoke position
- Use resolver sine wave to determine angular position of instrumented spoke when BOP strain is near zero and when BOP strain has large amplitude to identify plane

Instrumented Spoke Phase Based on Wheel Position

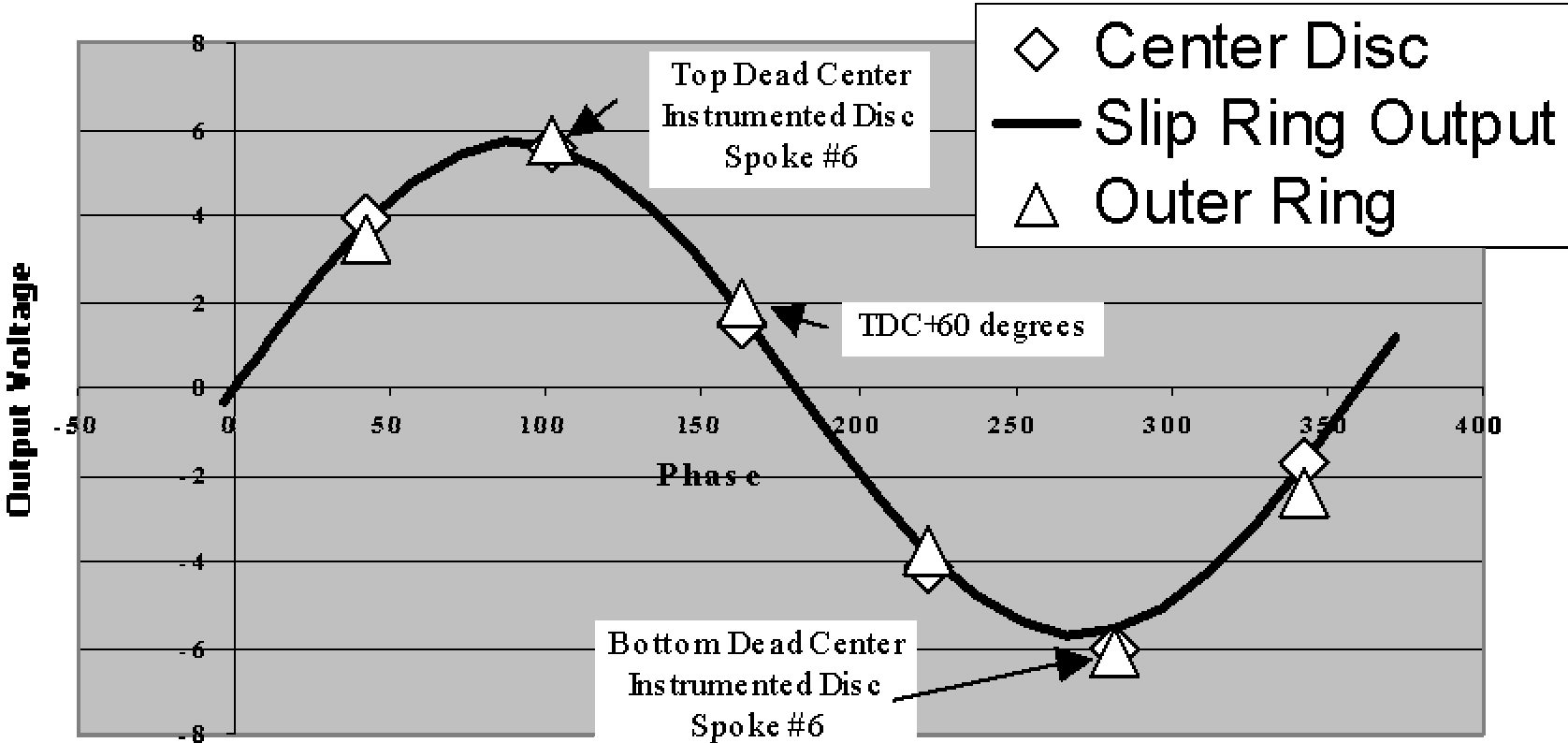

Spreader Bar Test

- Place hydraulic ram and load cell between the center brake disc and the outer brake disc at the outer circumference of the discs
- Apply a spreading force normal to the discs in turn at a radial position in line with each spoke of the center disc, and in line with each spoke of the outer disc
- Record strain from each spoke for each spreading force application

Force Applied at the Outer Perimeter of the Disc Friction Ring: 5.75 inches out from the inner radius of the friction ring
8 3/8 inches out from the hub
Force Applied Between the Center Disc and the Outer Disc in each case

Center Disc Spoke at which Force Applied	Force Applied [lb]	Strains Measured on Center Disc Spoke				Strains Measured on Outer Disc Spoke			
		Strain F1	Strain F2	Strain R1	Strain R2	Strain F1	Strain F2	Strain R1	Strain R2
6	-400	-10.4	-7.2	-73.5	56.3	-7.7	-12.3	53.2	-53.4
6	-504	-10.5	-7.1	-89.3	72.4	-7.9	-12.6	67.7	-65.5
1	-505	-9	-11.9	-53.9	30.8	-6.9	-12.8	38.5	-45.2
2	-510	-13.5	-11.6	-12.9	-13.4	-8.9	-14.2	-12.4	-10.1
3	-502	-10.6	-12	23	-48	-5.8	-13.5	-40.3	16.2
4	-503	-13.2	-8	-1.2	-22.4	-6.9	-10.3	-27.6	2.2
5	-504	-11.7	-4.9	-53.8	32.5	-9.4	-9.6	23.8	-33.6
6	-508	-8.6	-5.9	-89.1	74.1	-5.1	-9	67.1	-64.1

Part B: Residual Strains

Residual Strain Tests

- Performed By Mike Tomas (AMTRAK)
- Three Discs Examined
 1. WABTEC/SAB-WABCO Disc After Press Off Operation And After Spokes Cut
 2. Knorr Disc After Press On Operation
 3. WABTEC/SAB-WABCO Disc With Two Cracked Spokes After Spokes Cut
- Strain Gages On Spokes In The R1 And R2 Positions

Spoke Naming Convention

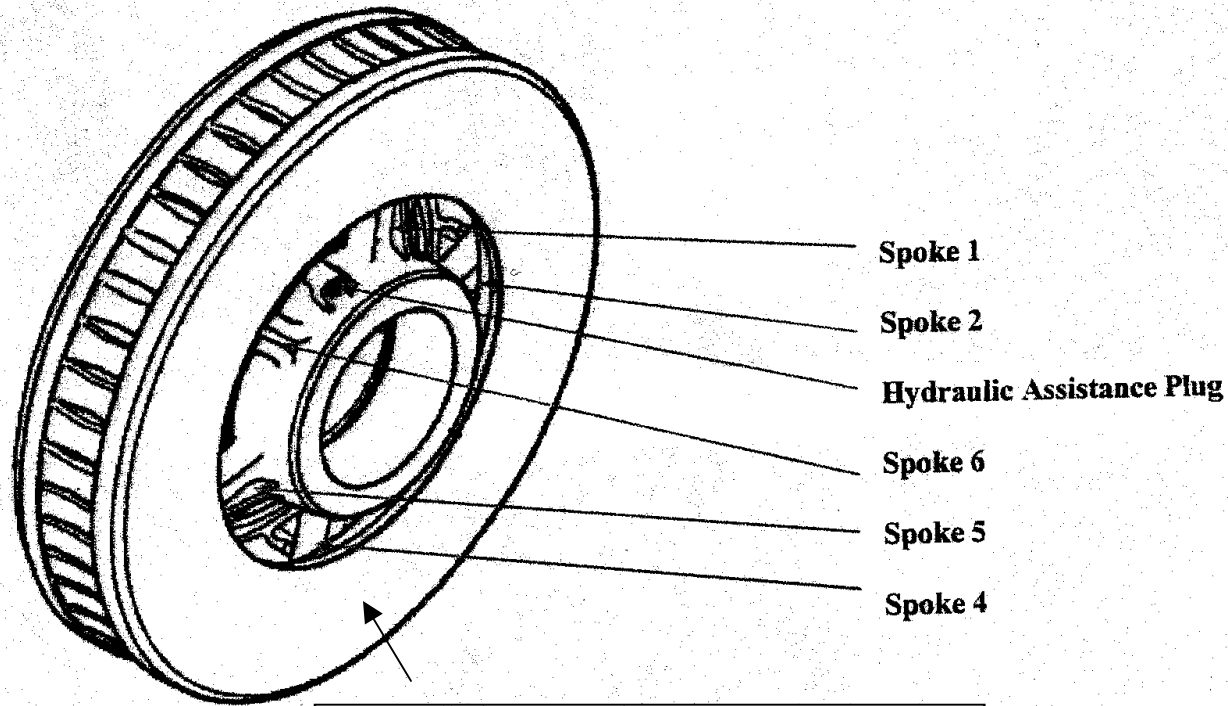

Nut Side–Side With Hydraulic Assistance Plug

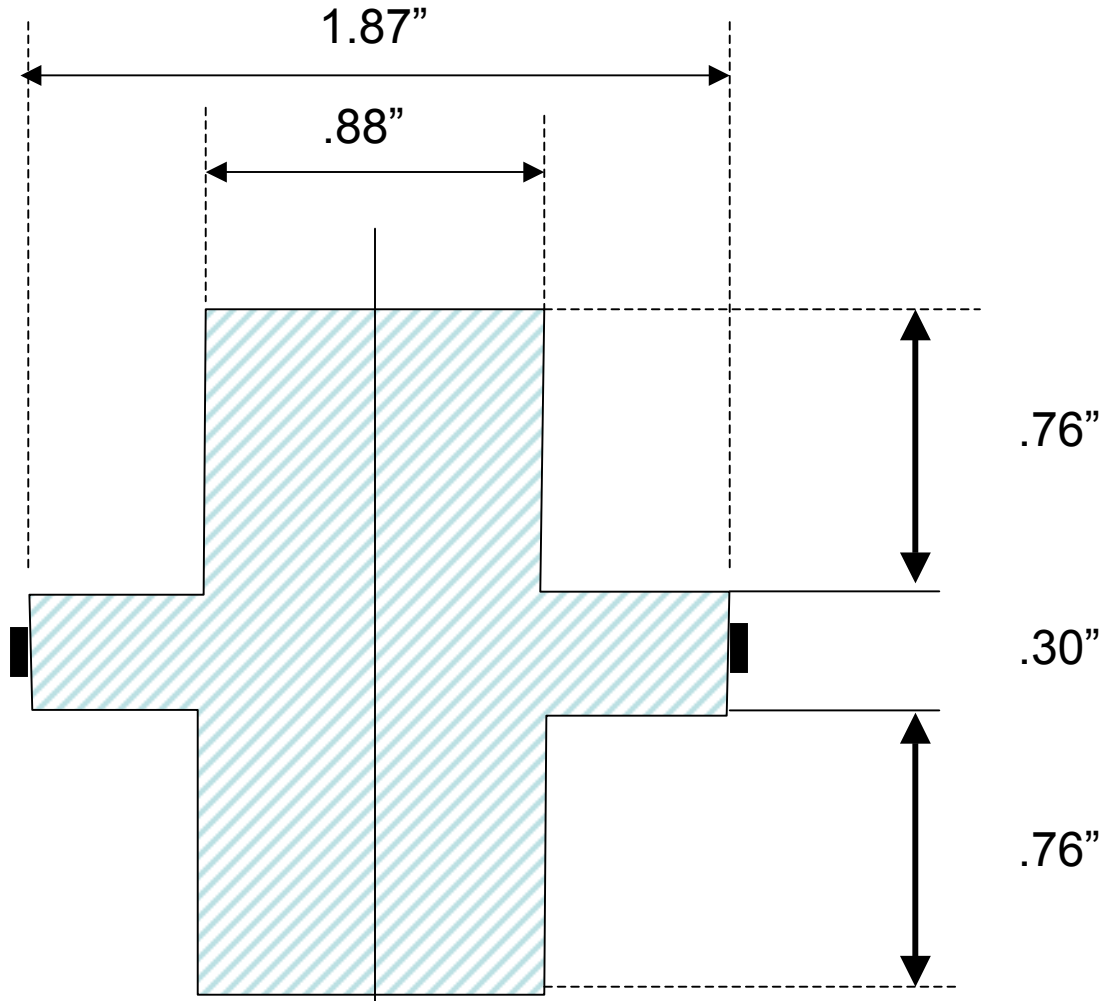

■ Strain Gages

Plane Of Disc

WABTEC/SAB-WABCO Disc

Table J.1. Spoke Cross Section Values

	WABTEC/ SAB-WABCO	Knorr
Area	1.9 in ²	3.6 in ²
Moment Of Inertia (Bending In-Plane)	0.44 in ⁴	0.85 in ⁴
Moment Of Inertia (Bending Out-Of-Plane)	0.25 in ⁴	1.69 in ⁴

Disc 1 WABTEC/SAB-WABCO

- Interference Fit Parameters
 - Allowable .009 to .012”
 - Press Force 27 to 84 Tons

- Disc 1
 - Interference Fit .0097”
 - Press Force 54 Tons

Key Values

- $E = 30.5 \cdot 10^6$ psi
- Cross Sectional Area Of Spoke At Strain Gage Location 1.9 in^2
- Negative Strains Indicate A Reduction In Compressive Pre-Strain

**Table J.2. WABTEC/SAB-WABCO Disc 1
Pre-Strain, Disc Removal**

WABTEC/SAB-WABCO Disc–Good condition with approximately 1,500 to 2,000 miles service. Disc removed from axle 4 on car 3534, May 28, 2005. Press off operation.					
	Nut Side	Other Side			Estimate Force in Spoke (kips)
Spoke	Resultant Strain		Resultant Average Strain	Resultant Bending Strain	
1	-330	-436	-383	53	22.2
2	-356	-480	-418	62	24.2
3	-400	-295	-348	-52.5	20.1
4	-392	-374	-383	-9	22.2
5	-364	-360	-362	-2	21.0
6	-348	-541	-445	96.5	25.8
Average			-390	25	23

WABTEC/SAB-WABCO Disc 1

Press Off Operation

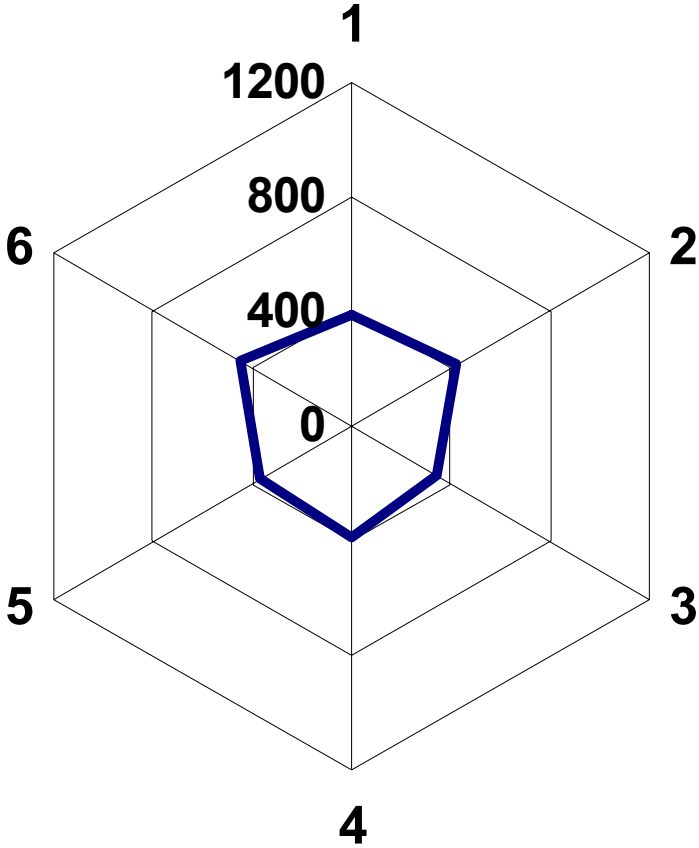

Test Of Observed Pre-Strain Reduction

- Assume:
 - Pre-Strain Produces Only Compressive Force Along The Axis Of The Spoke
 - This Force Can Be Estimated By The Mean Observed Strain (Average Of The Right And Left Strain Gages) Times The Cross Section Area Of Section
 - The Six Forces Acting On The Friction Disc Should Be In Equilibrium

Spoke Forces On Friction Rings

$$\sum_{i=1}^6 F_i = 0$$

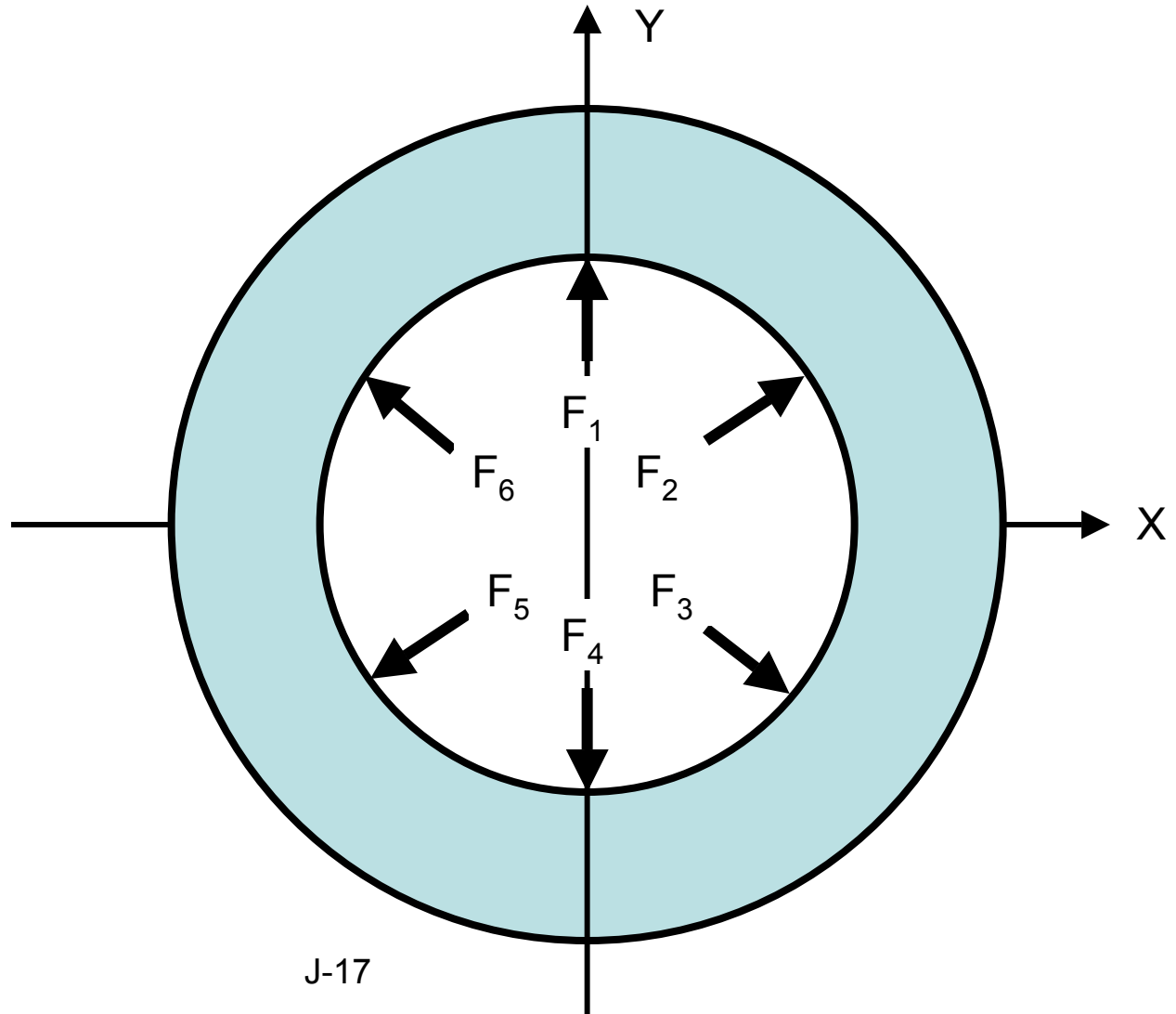
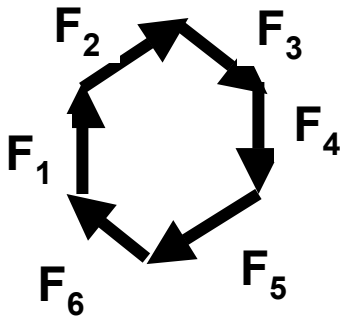

Summation Of Spoke Forces

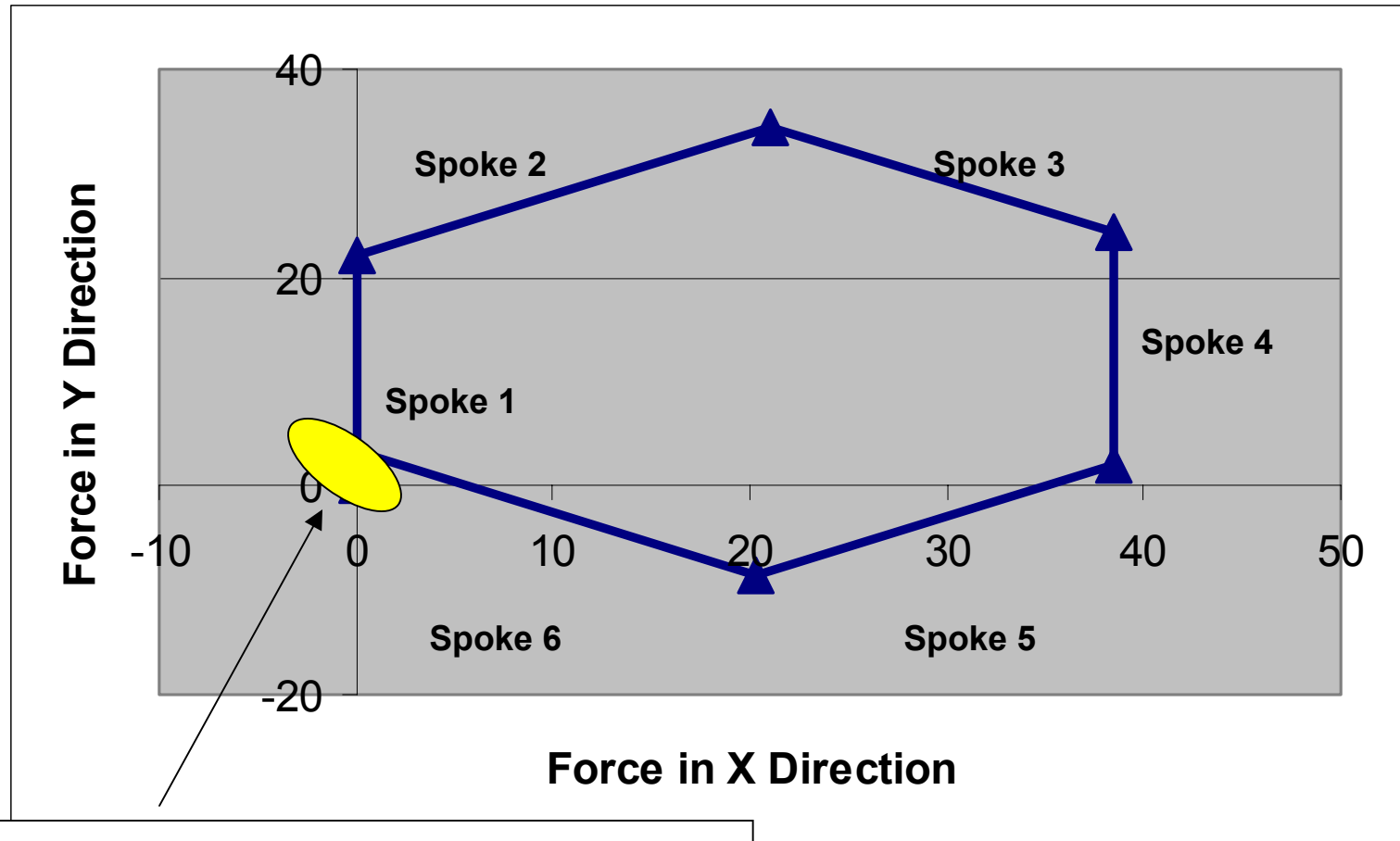

**Table J.3. WABTEC/SAB-WABCO Disc 1
Pre-Strain, Spoke Cutting**

Spokes cut to relieve any pre-stress. WABTEC/SAB-WABCO Disc–Good condition with approximately 1,500 to 2,000 miles service. Disc removed from axle 4 on car 3534, May 28, 2005.					
	Nut Side	Other Side			Estimate Force in Spoke (lbs)
Spoke	Resultant Strain		Resultant Average Strain	Resultant Bending Strain	
1	-602	-650	-626	24	36.3
2	-567	-630	-599	31.5	34.7
3	-613	-455	-534	-79	30.9
4	-694	-444	-569	-125	33.0
5	-697	-467	-582	-115	33.7
6	-656	-725	-691	34.5	40.0
Average			-600	-38	35

WABTEC/SAB-WABCO Disc 1 Spokes Cut

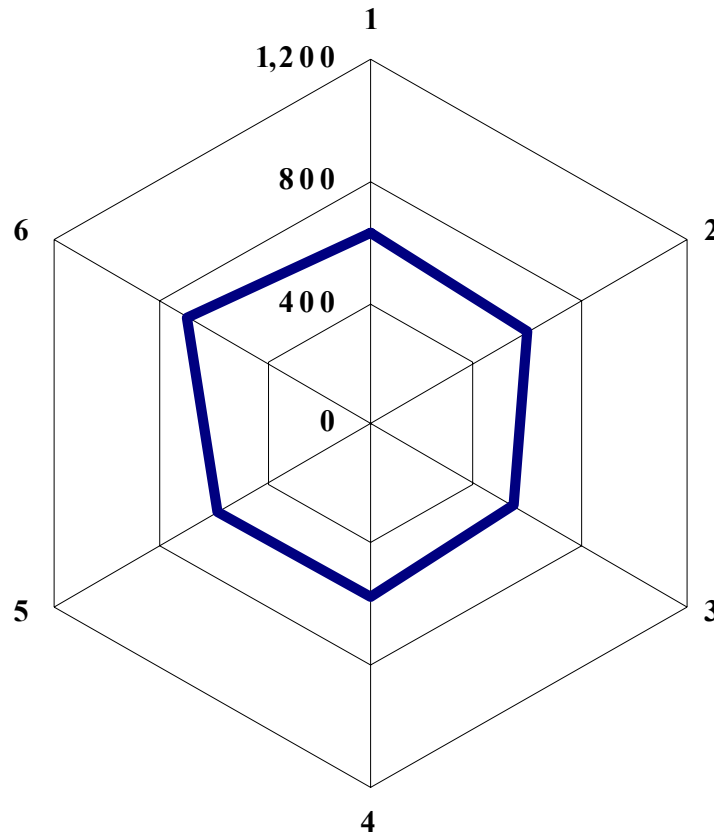

J-20

Spoke Force Summation Disc 1

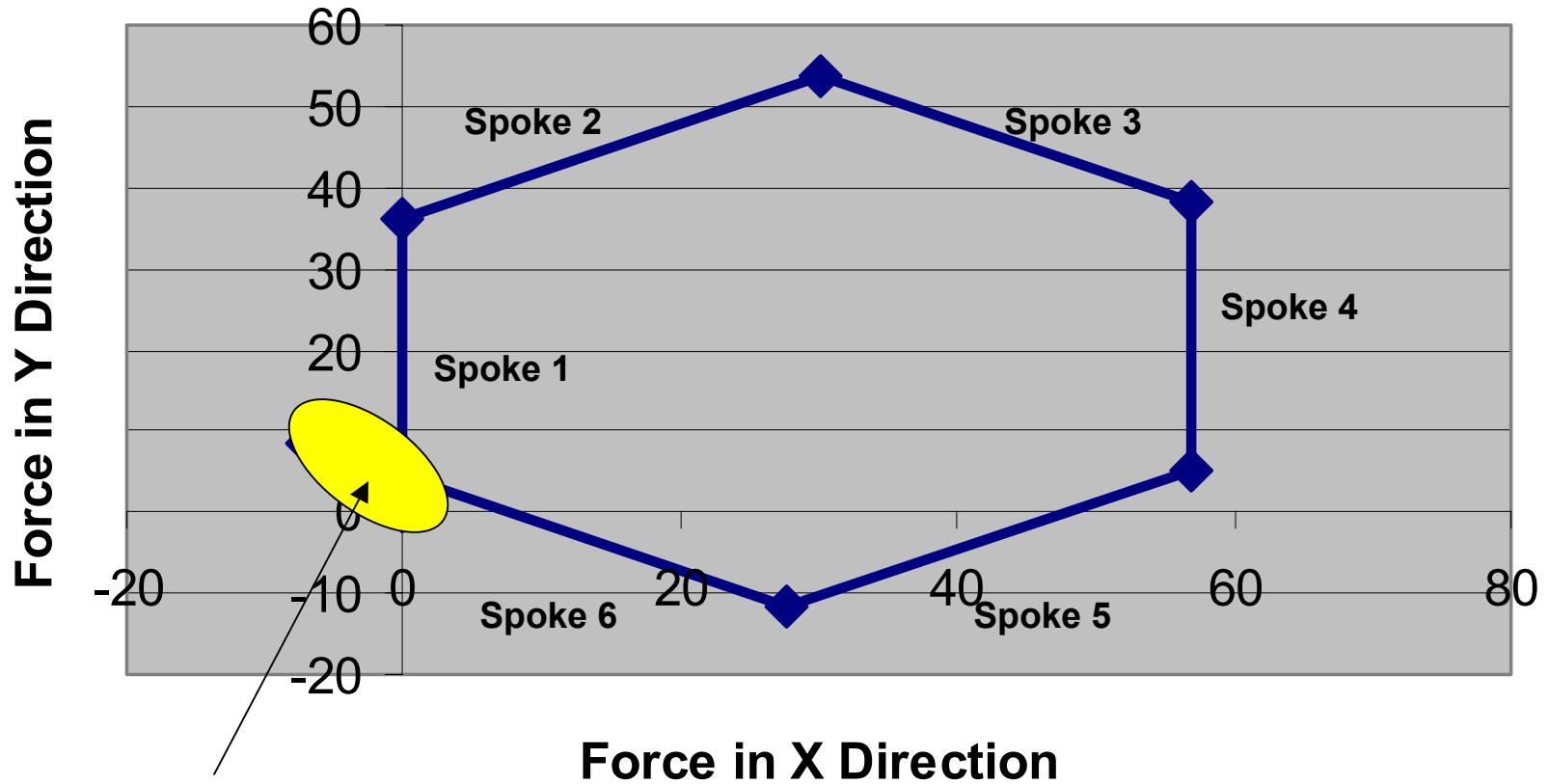

Indicates near equilibrium conditions

Table J.4. WABTEC/SAB-WABCO Disc 1
Pre-Strain, Disc Removal and Disc Cutting

Combined Residual Strain (Both Compressive)					
	Nut Side	Other Side	Resultant Average Strain	Resultant Bending Strain	Estimate Force in Spoke (lbs)
Spoke	Resultant Strain				
1	-932	-1,086	-1,009	77	58
2	-923	-1,110	-1,017	94	59
3	-1,013	-750	-882	-132	51
4	-1,086	-818	-952	-134	55
5	-1,061	-827	-944	-117	55
6	-1,004	-1,266	-1,135	131	66
Average			-990	-14	57

Disc 1

Combined Relieved Strain

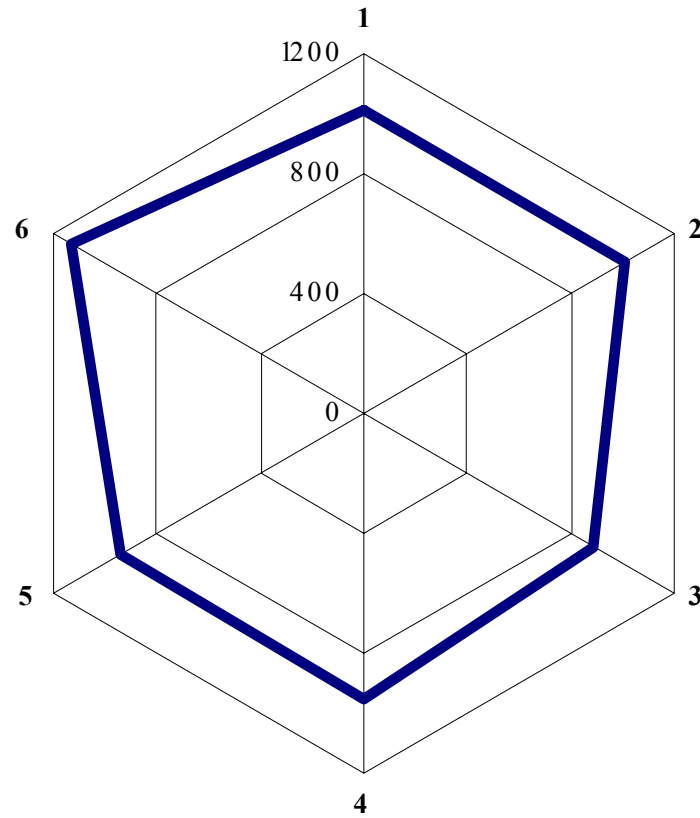

J-23

Disc 1 Combined

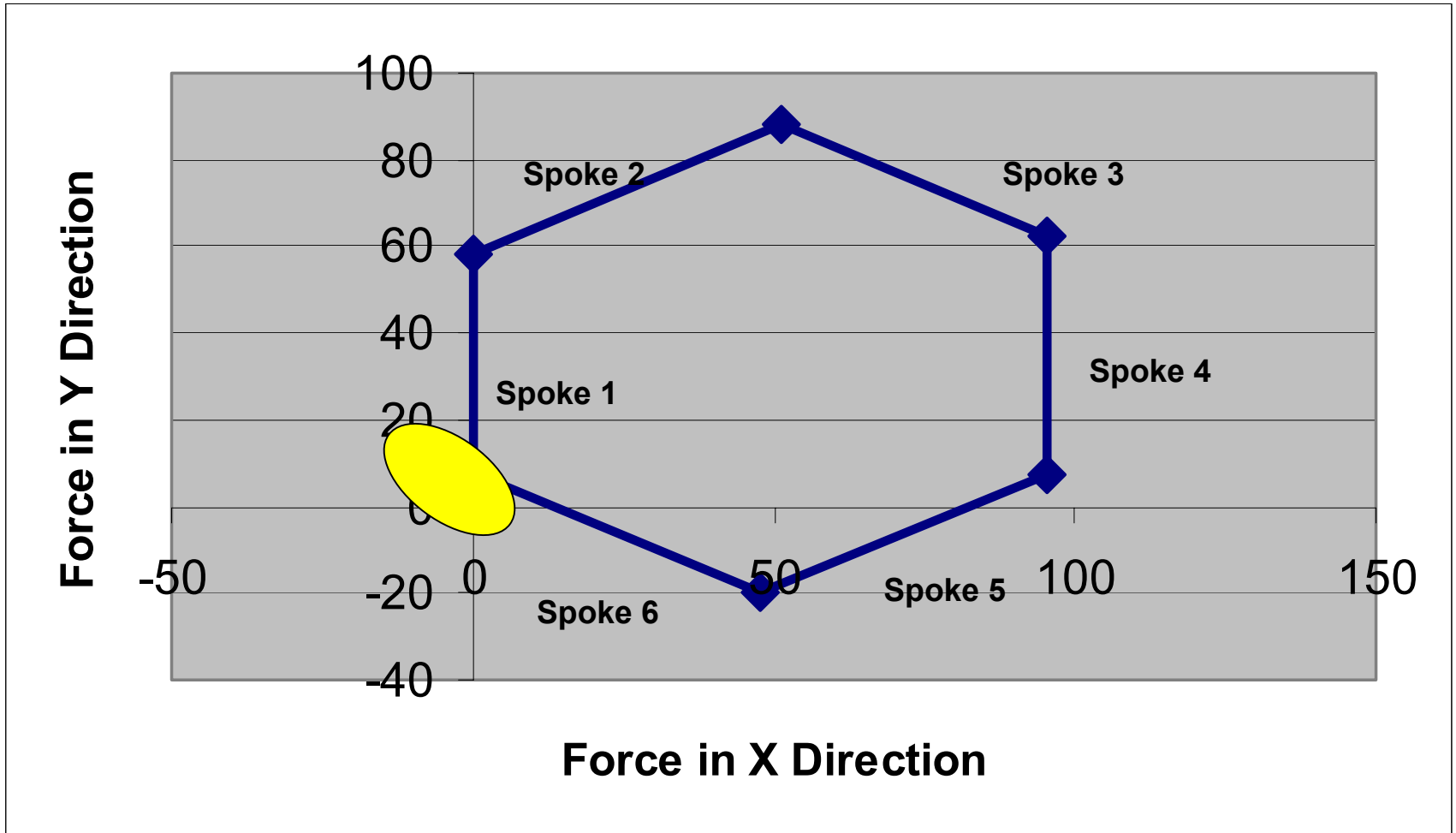
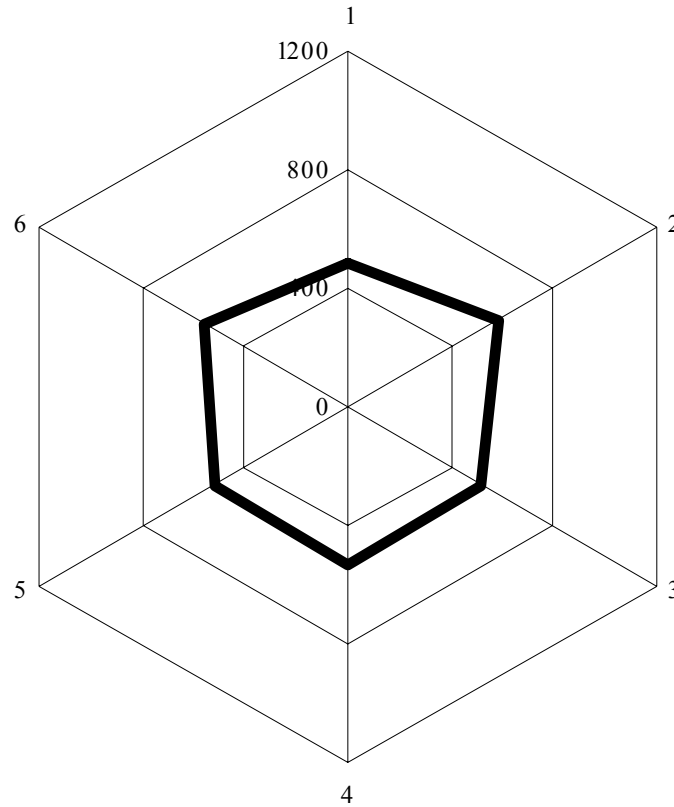

**Table J.5. Knorr Disc 2 Pre-Strain,
Disc Installation**

Knorr Press On					
	Nut Side	Other Side			Estimate Force in Spoke (lbs)
Spoke	Resultant Strain		Resultant Average Strain	Resultant Bending Strain	
1	-491	-484	-488	-3.5	54
2	-637	-524	-581	-56.5	64
3	-503	-530	-517	13.5	57
4	-460	-612	-536	76	59
5	-513	-524	-519	5.5	57
6	-531	-585	-558	27	61
	Average		-533	10	59

Knorr Disc

Disc 2



J-26

Knorr Disc Disc 2

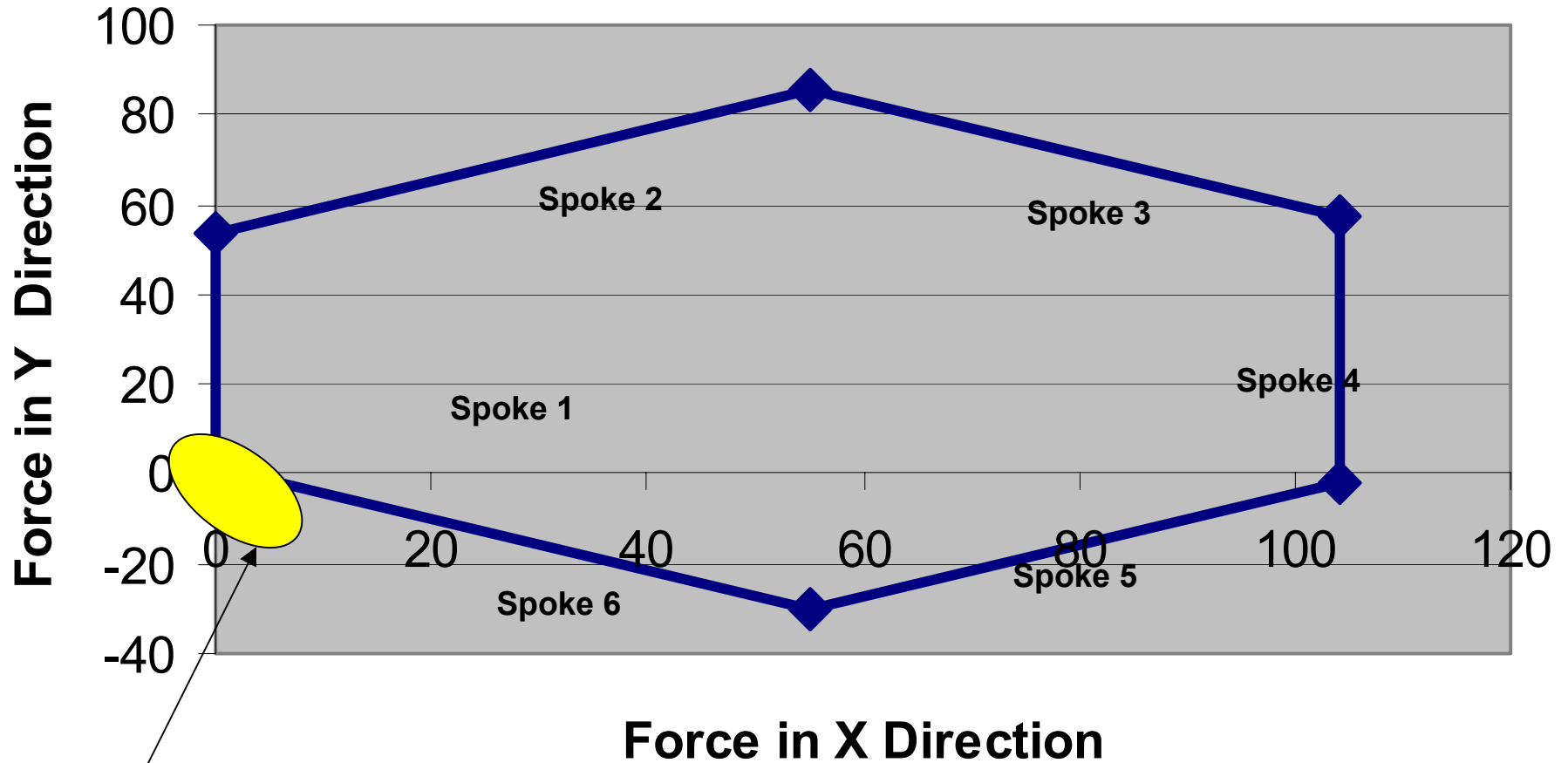

Indicates near equilibrium conditions

Disc 2 Knorr



Photo Courtesy of J. Gordon, Volpe National Transportation Center

Spoke Strain Gage On Knorr Disc



Photo Courtesy of J. Gordon, Volpe National Transportation Center

Spoke Strain Gage On Knorr Disc

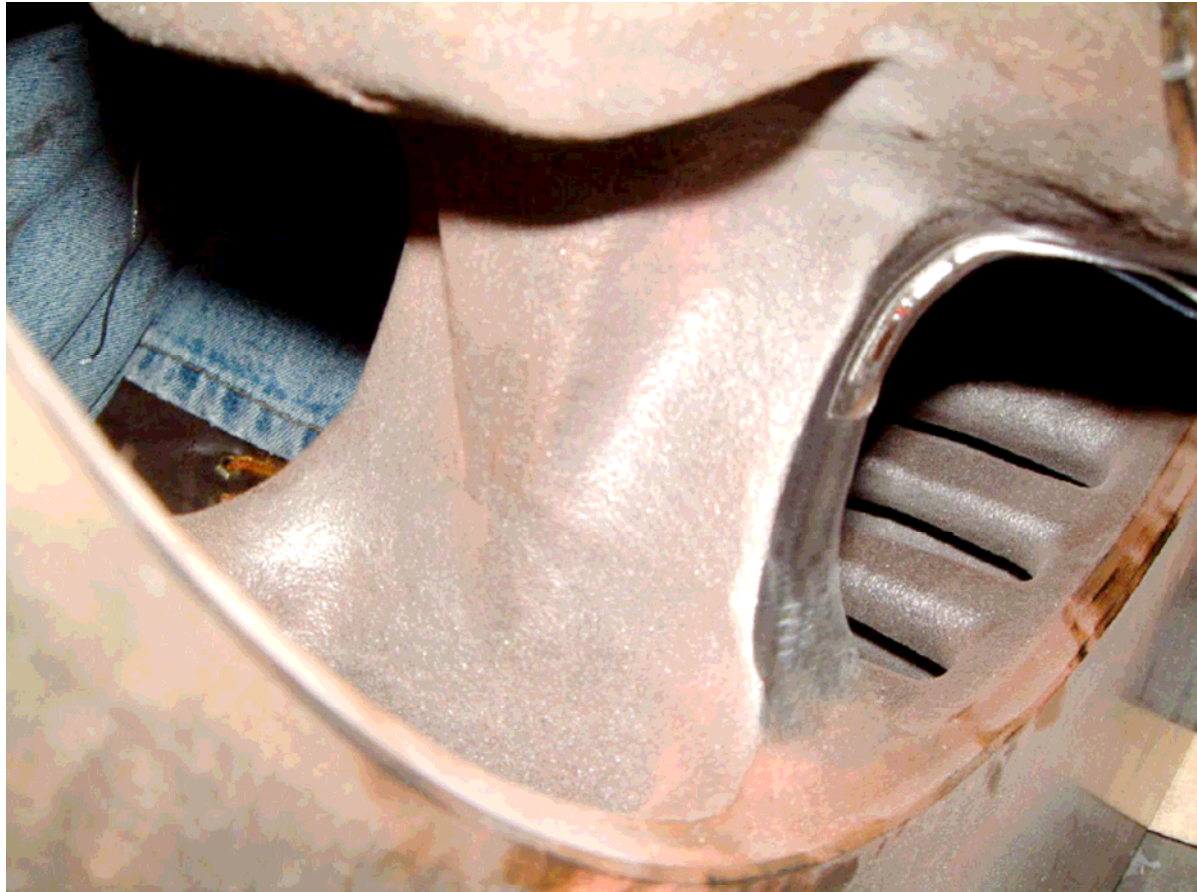

Photo Courtesy of J. Gordon, Volpe National Transportation Center

Material Properties

Knorr Disc

- Reported by Volpe
 - Yield Strength 850-900 MPa
 - Ultimate Strength 1000-1050 MPa

 - Yield Strength 123-130 ksi
 - Ultimate Strength 145-152 ksi

Disc 3 WABTEC/SAB-WABCO Disc With Two Cracked Spokes

- Cracked Spokes—No Pre-Stress
- Other Spokes:
 - Strain Levels Less Than In Disc 1 After Press Off Operation
 - Large Values Of Bending Strain

Table J.6. WABTEC/SAB-WABCO Disc 3
Pre-Strain, Spoke Cutting with Two Cracked Spokes

WABTEC/SAB-WABCO Disc with Two Cracked Spokes					
	Nut Side	Other Side	Resultant Average Strain	Resultant Bending Strain	Estimate Force in Spoke (lbs)
Spoke	Resultant Strain				
1	N/A	-681	N/A	N/A	N/A
2	-1,219	-386	-803	-416.5	47
3	-2	31	15	-16.5	-1
4	2	N/A	N/A	N/A	N/A
5	-580	-779	-680	99.5	39
6	N/A	-474	N/A	N/A	N/A
Average			-741	N/A	N/A

Note: Average Based on Spokes 2 and 5

Summation Of Spoke Forces

- The Equilibrium Conditions Cannot Be Met With The Two Broken Spokes Under The Assumption Stated Above

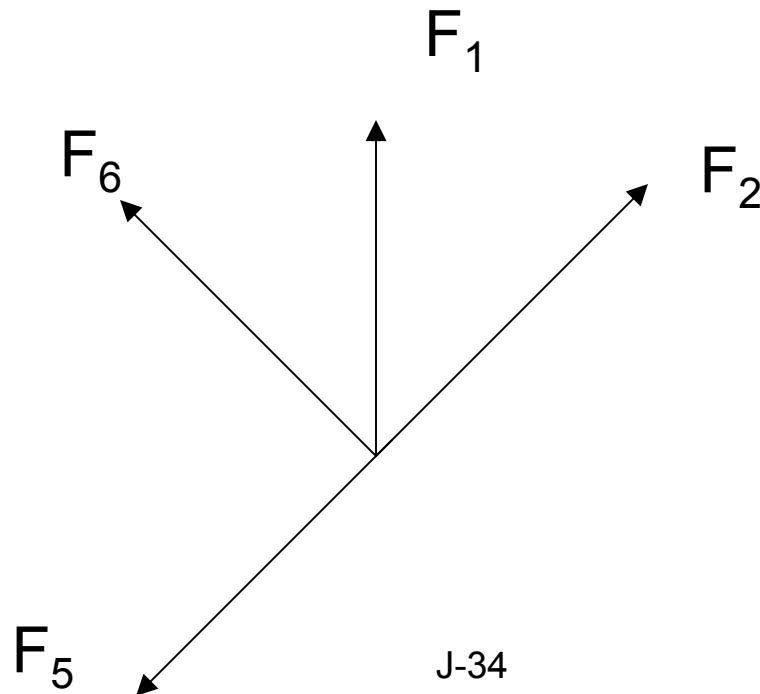

Comments

- Spokes Compressive Force Must Be Augmented With Shear Forces In The Spoke
- The Available Test Data Does Not Allow This Force To Be Calculated
- The Large Bending Strain In Spoke 2 May Indicate Shear In Spoke 2

Cracked Spoke



Photo Courtesy of M. Tomas, Amtrak

Cracked Spoke



Photo Courtesy of M. Tomas, Amtrak

Observations

- These observations based on limited sample:
 - One WABTEC/SAB-WABCO disc (press off and cutting of spokes)
 - One WABTEC/SAB-WABCO disc with two cracked spokes (cutting of spokes)
 - One Knorr disc (press on)
 - Extrapolation to total population will require more samples
- WABTEC/SAB-WABCO disc:
 - Press off operation relieved strain 360 to 440 microstrain
 - Cutting the spokes relieved strain 530 to 690 microstrain
 - Retired disc with two cracked spokes, showed no pre-strain in the two cracked discs
 - Retired disc with two cracked spokes, showed retained strain level of 680-800 microstrain on two spokes (the other two spokes did not have gage readings on both sides of spoke, but one-sided strain of 475 and 680 microstrain)
- Knorr disc:
 - Press on operation produced strain level of 490-580 microstrain

Part C: Vibration Analysis

Acela Wheelset



- Static Vibration Tests Conducted On Two Wheelsets Using Acceleration Measurements:
 - One With WABTEC/SAB-WABCO Discs, One With Knorr Discs
 - Each Wheelset Removed From Truck, Resting On Shop Floor

Test Conditions-1

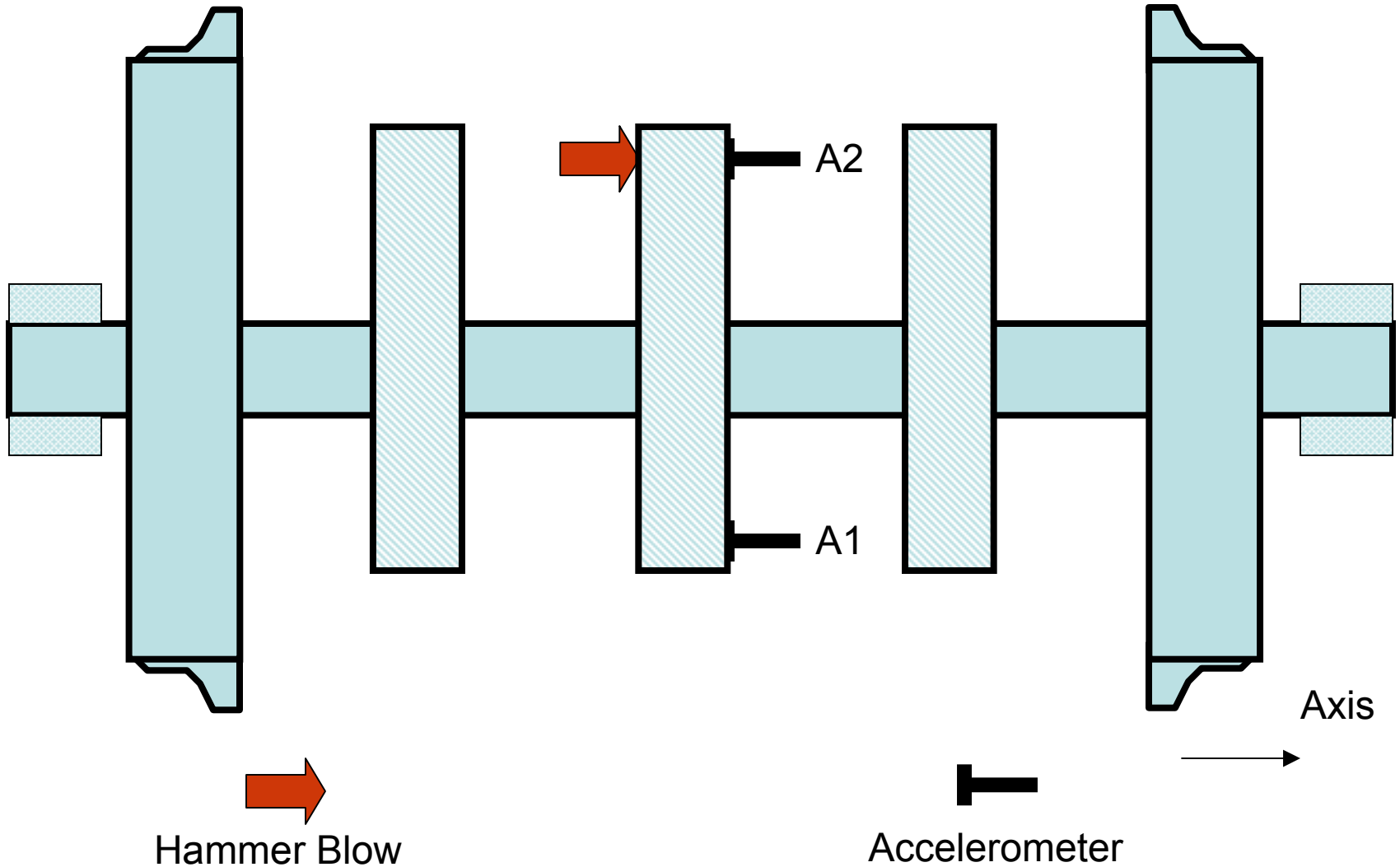

Test 1–Analysis Conditions

- 45 Oz Dead Blow Hammer Used For Force Input
- FFT Over 1-Second Window,
Approximately 1/2 Second After Impact
- Channel 1–Accelerometer A1
Channel 2–Accelerometer A2

Vibration Analysis—Test Condition 1

WABTEC/SAB-WABCO Disc

Knorr Disc

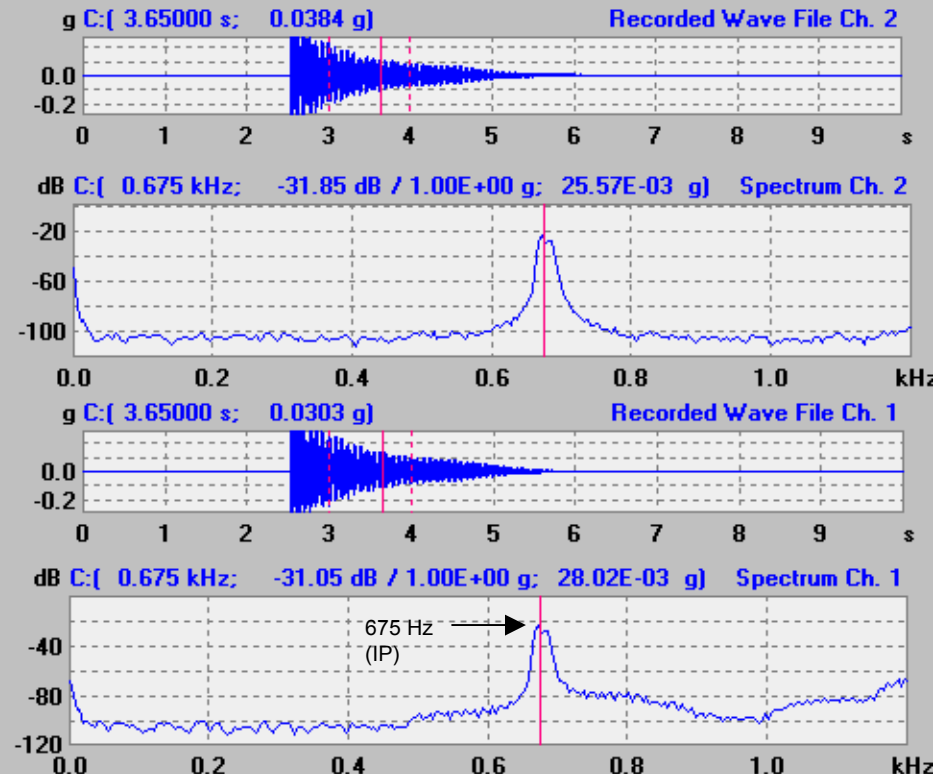
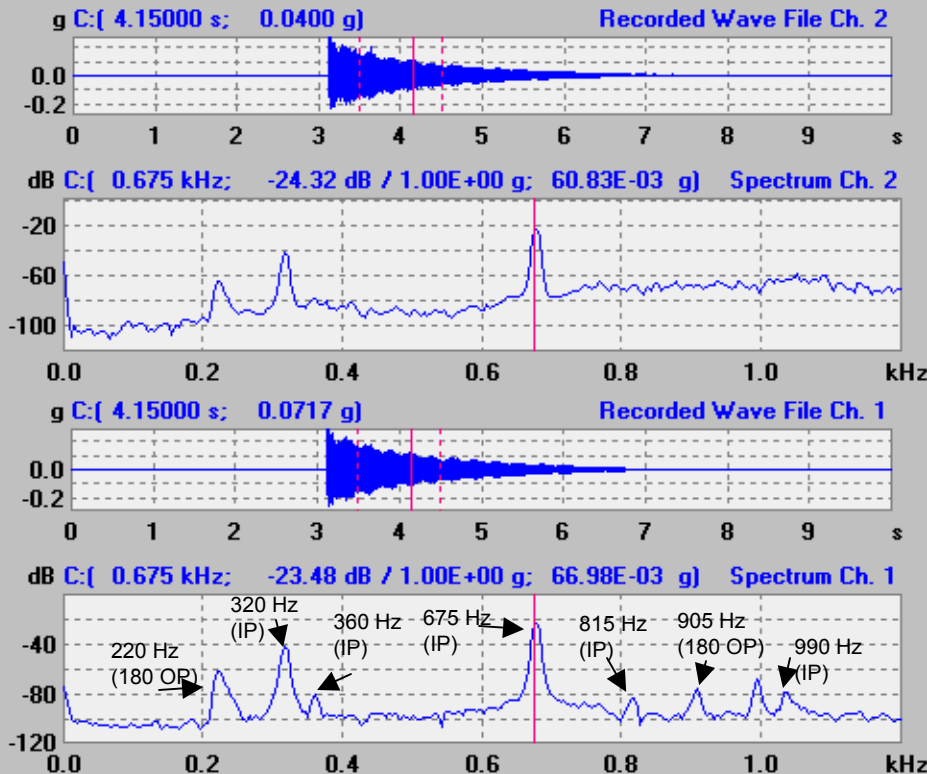

Vibration Analysis—Test Condition 1

WABTEC/SAB-WABCO Disc

Knorr Disc

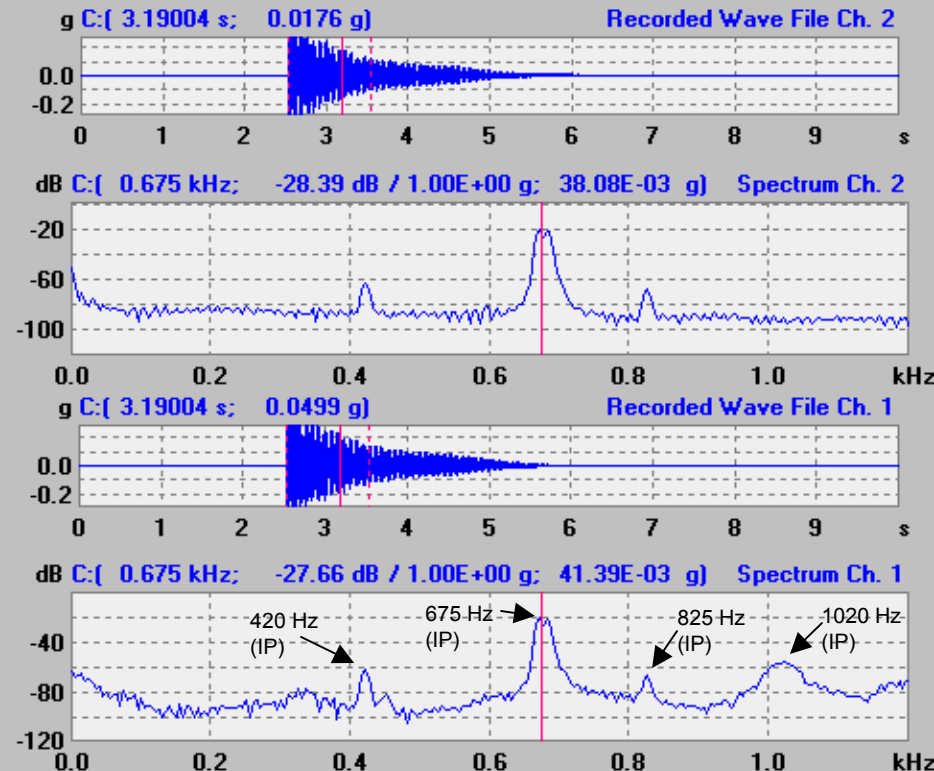
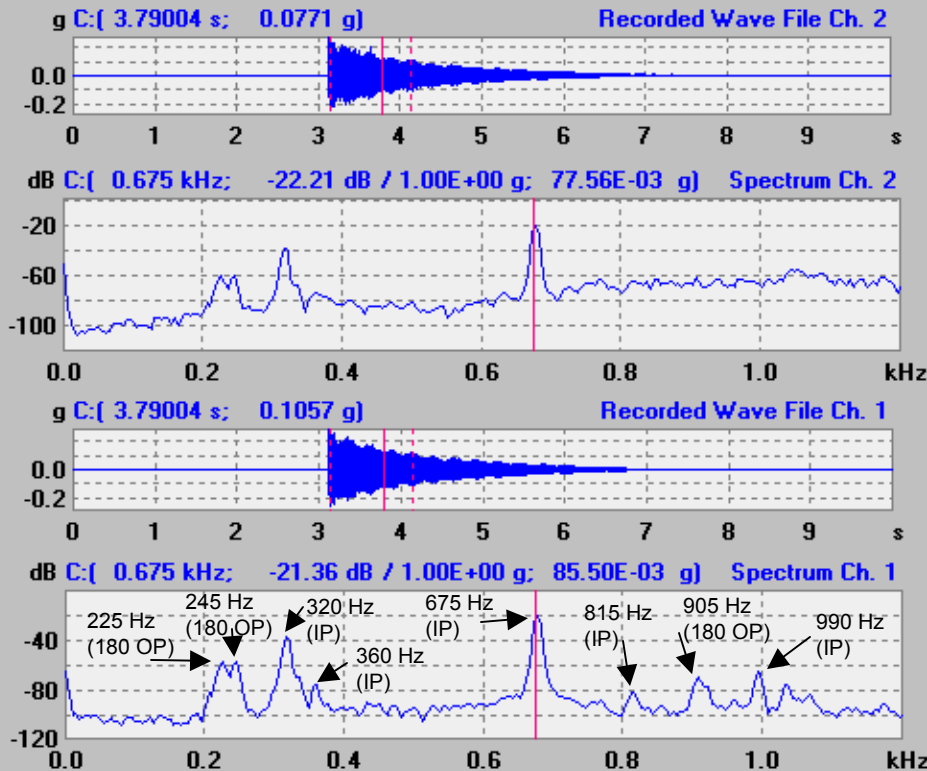

Test Conditions-2

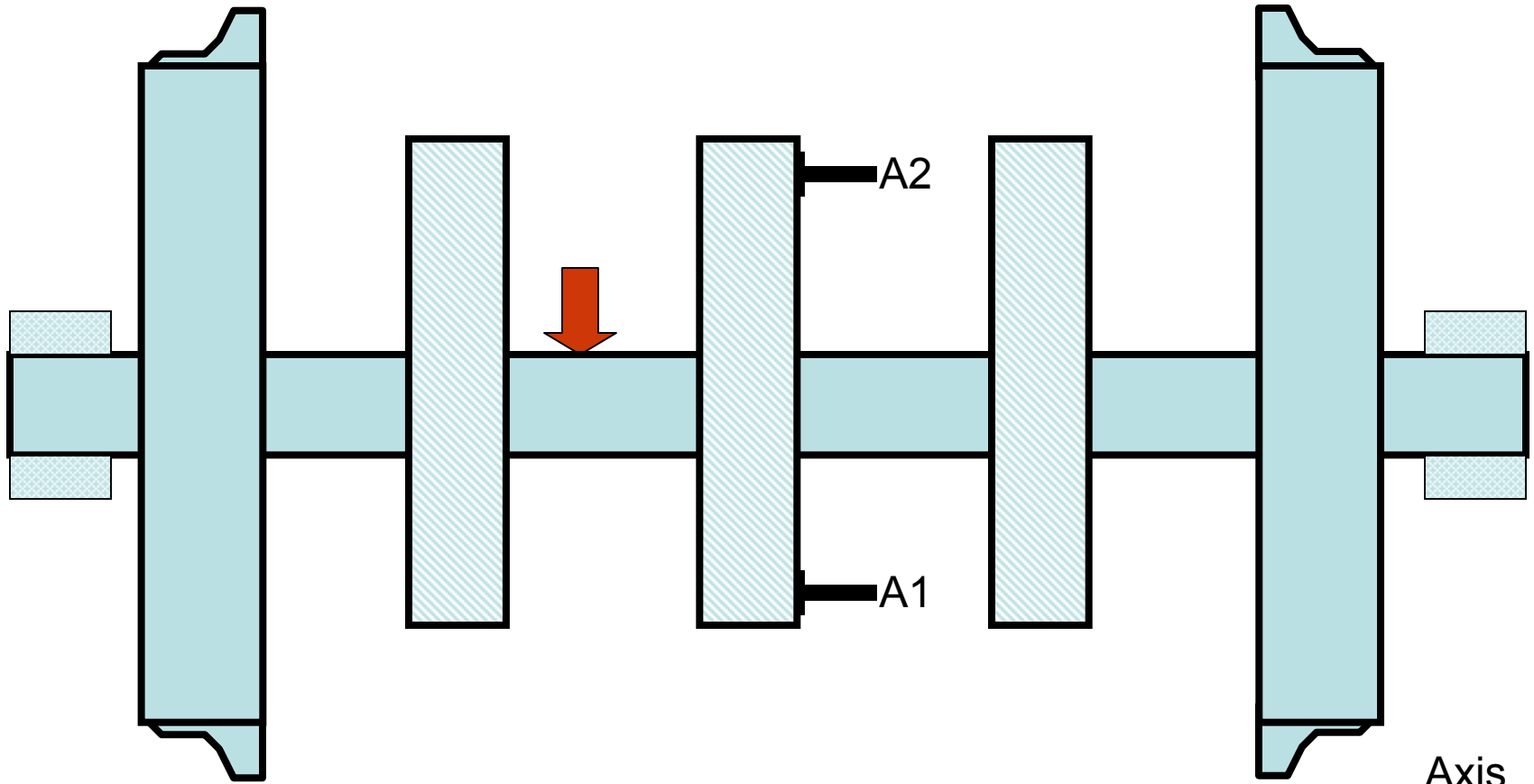

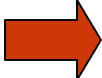
Hammer Blow

Accelerometer

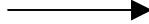
Axis

Test 2–Analysis Conditions

- 45 Oz Dead Blow Hammer Used For Force Input
- FFT Over 1-Second Window, Right After The Impact
- Channel 1–Accelerometer A1
Channel 2–Accelerometer A2

Vibration Analysis—Test Condition 2

WABTEC/SAB-WABCO Disc

Knorr Disc

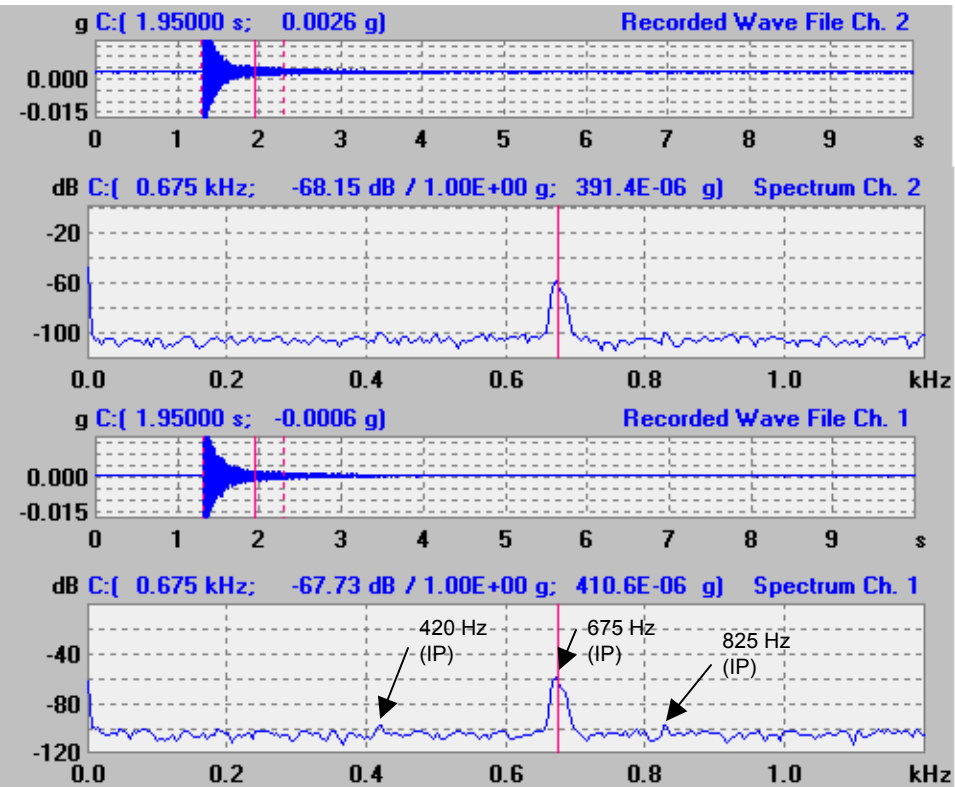
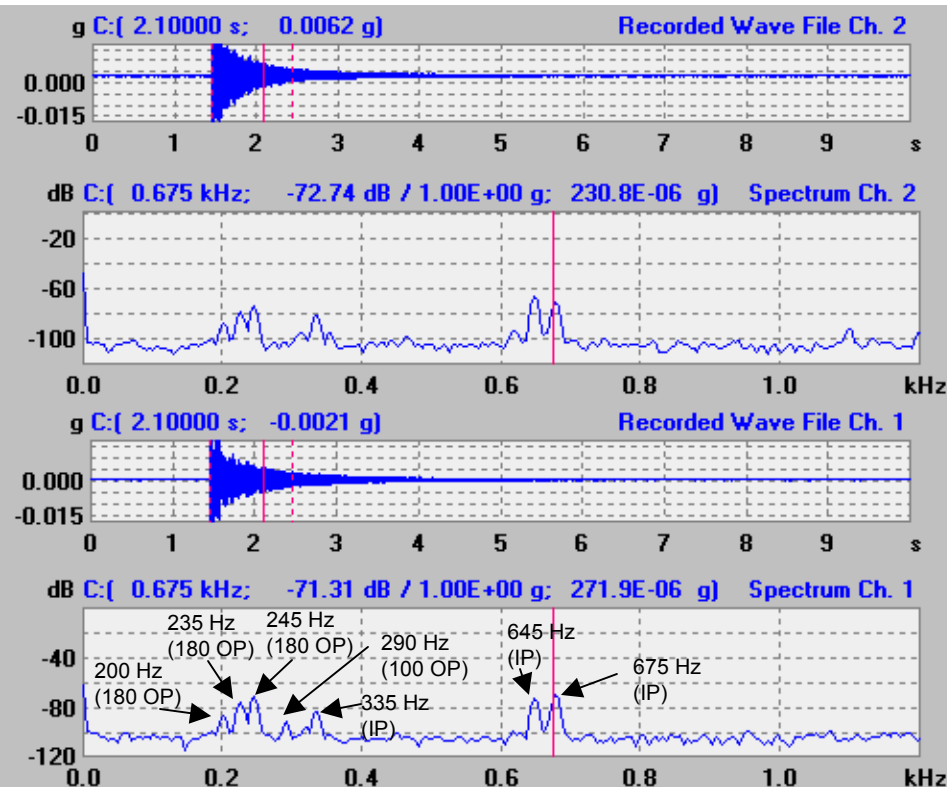

Test Conditions-3

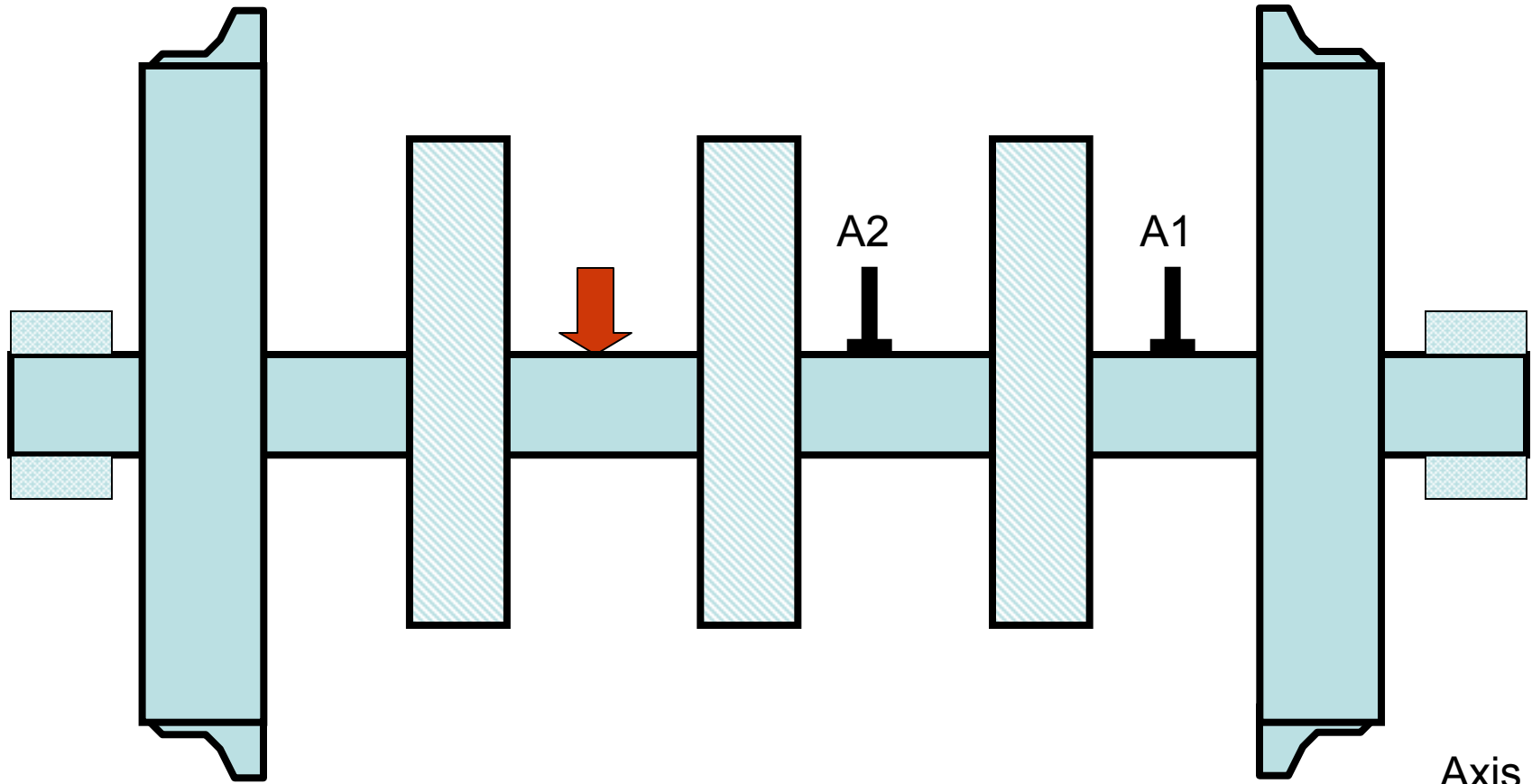

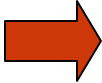
Hammer Blow

Accelerometer

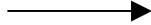
Axis 

Test 3–Analysis Conditions

- 45 Oz Dead Blow Hammer Used For Force Input
- FFT Over 1-Second Window, Right After The Impact
- Channel 1–Accelerometer A1
Channel 2–Accelerometer A2

Vibration Analysis—Test Condition 3

WABTEC/SAB-WABCO Disc

Knorr Disc

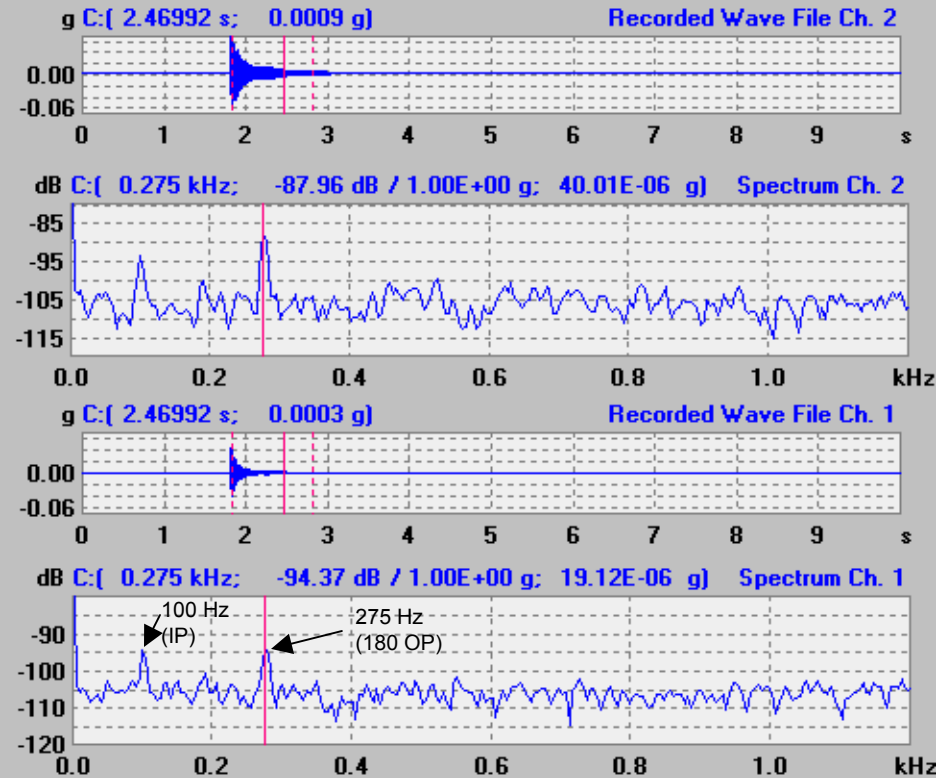
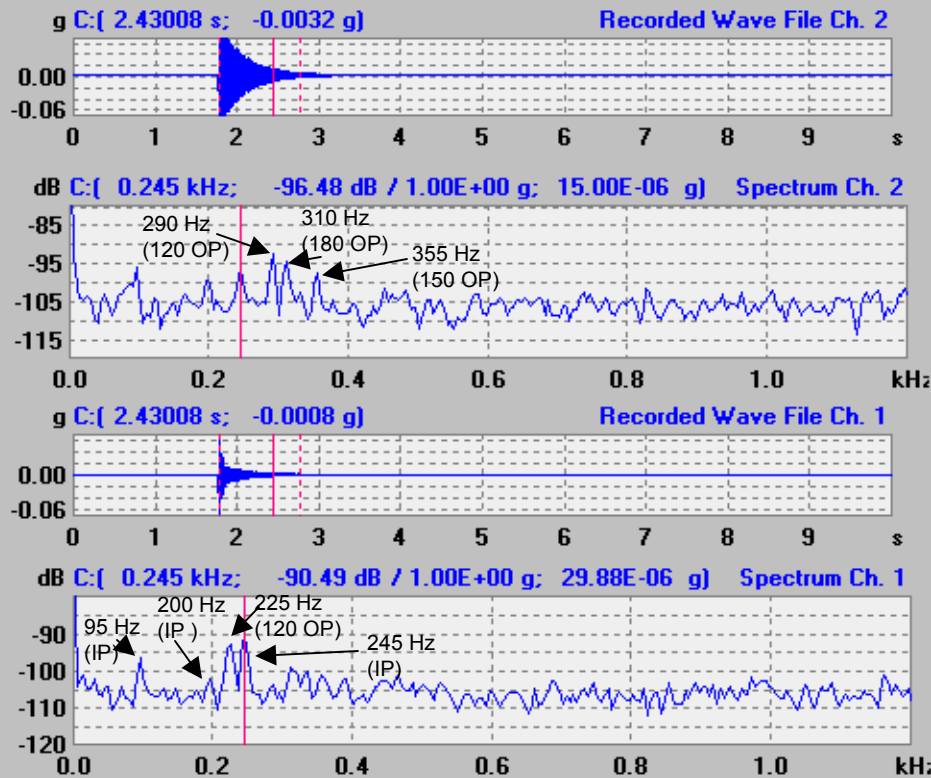

Test Conditions-4

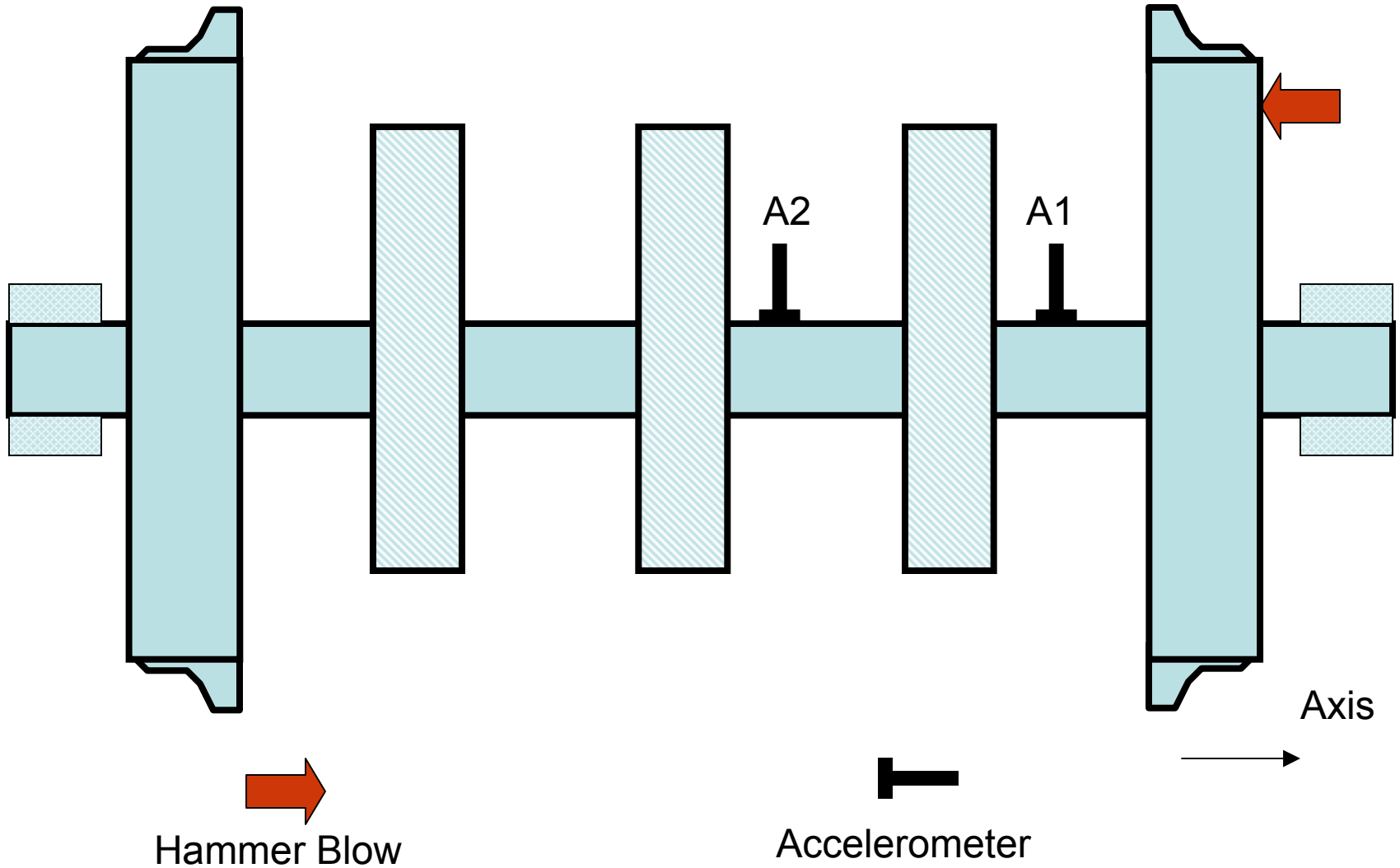

Test 4–Analysis Conditions

- 45 Oz Dead Blow Hammer Used For Force Input
- FFT Over 1-Second Window, Right After The Impact
- Channel 1–Accelerometer A1
Channel 2–Accelerometer A2

Vibration Analysis—Test Condition 4

WABTEC/SAB-WABCO Disc

Knorr Disc

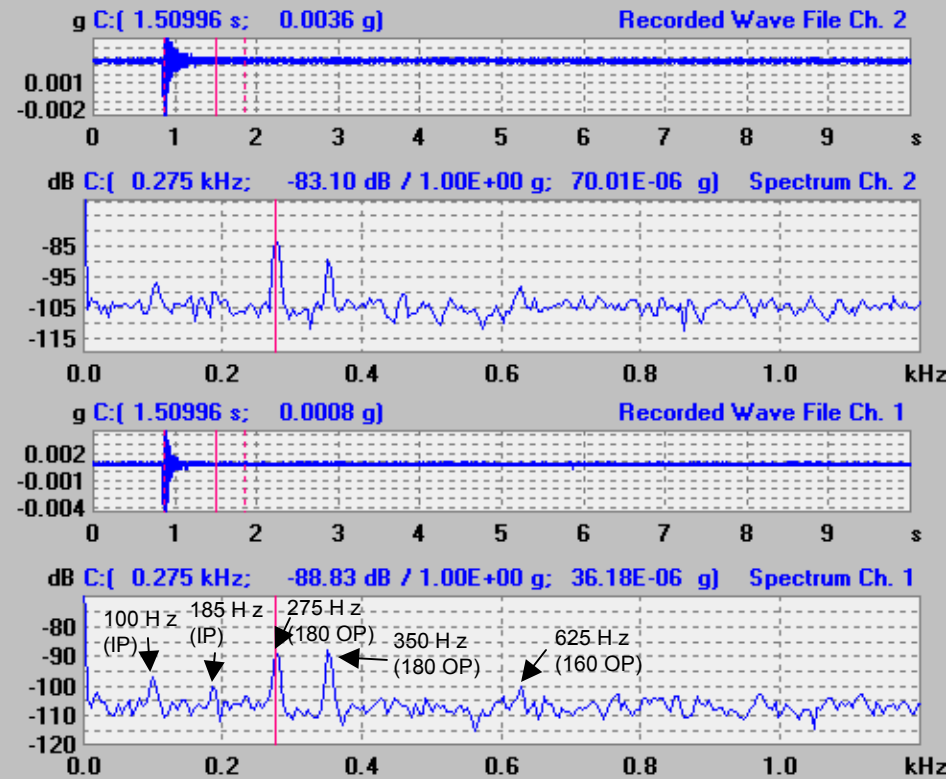
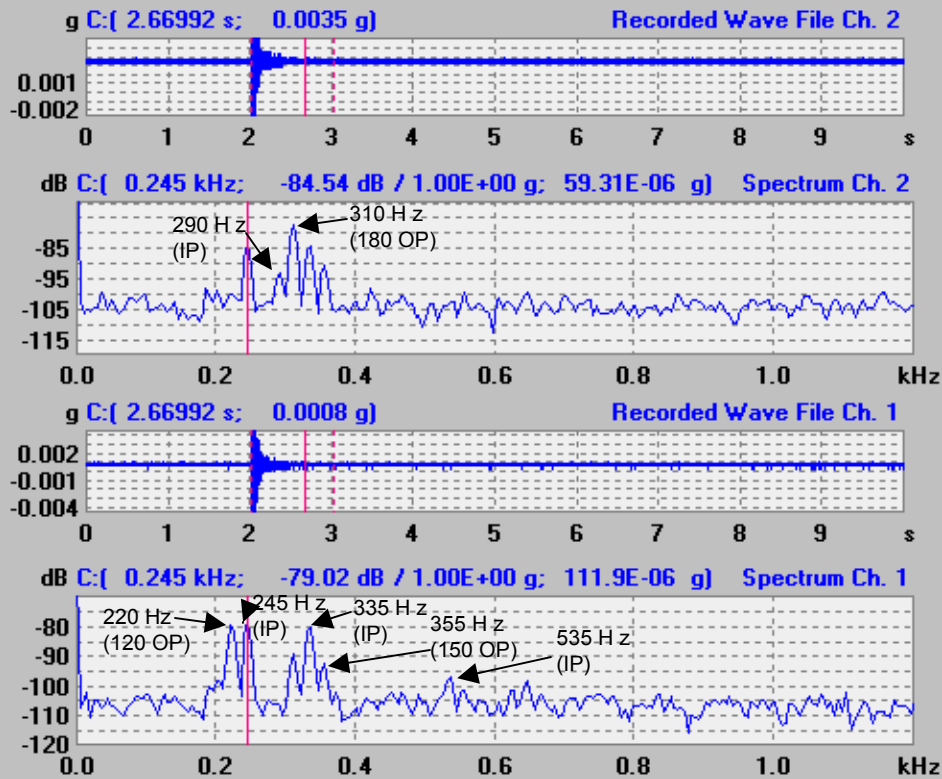

Test Conditions-5

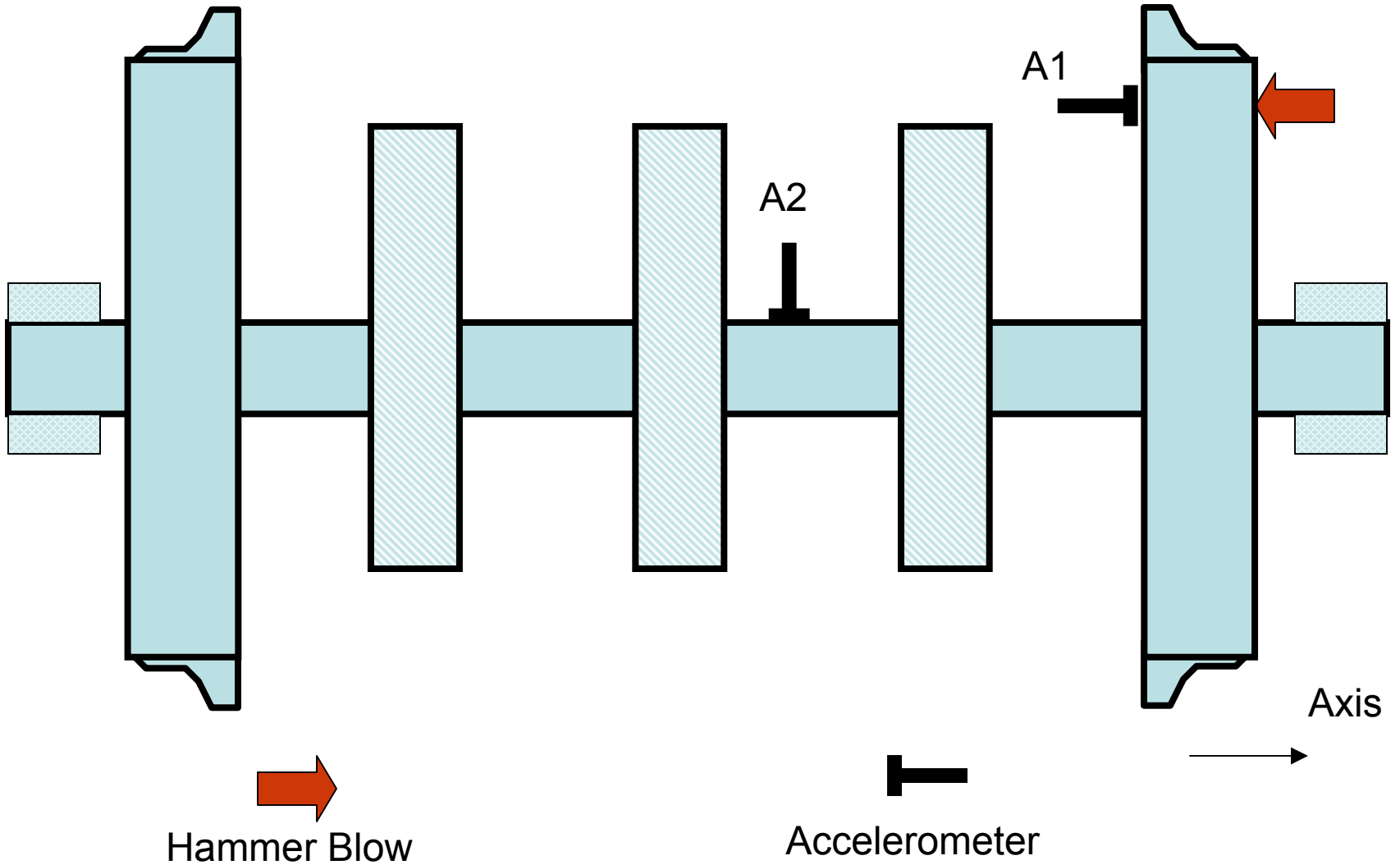

Test 5–Analysis Conditions

- 45 Oz Dead Blow Hammer Used For Force Input
- FFT Over 1-Second Window, Right After The Impact
- Channel 1–Accelerometer A1
Channel 2–Accelerometer A2

Vibration Analysis—Test Condition 5

WABTEC/SAB-WABCO Disc

Knorr Disc

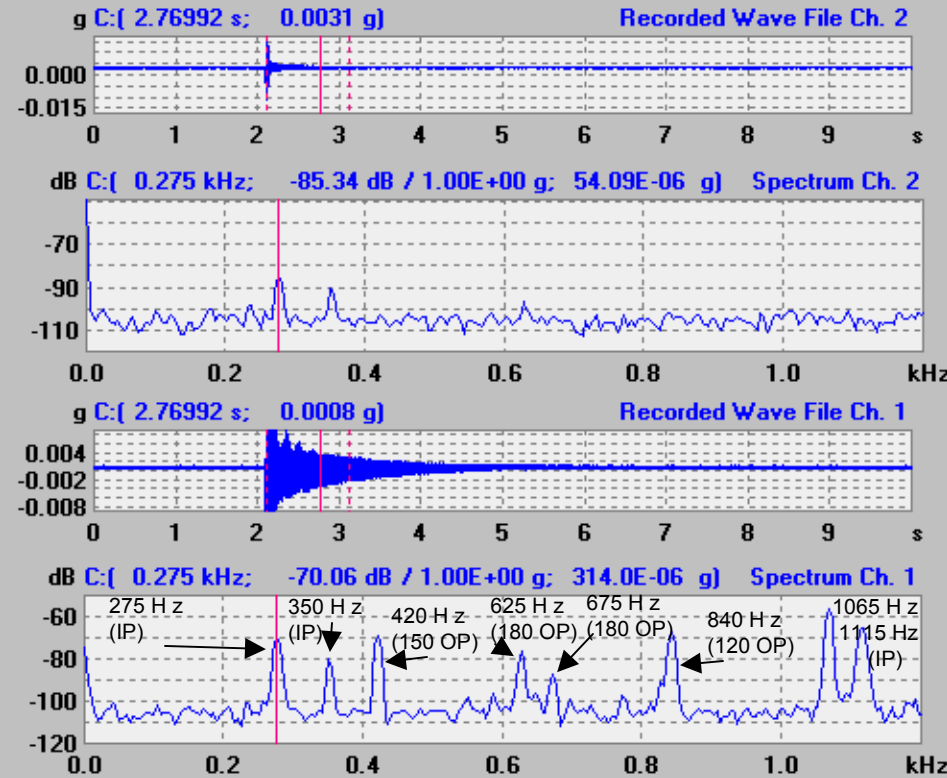
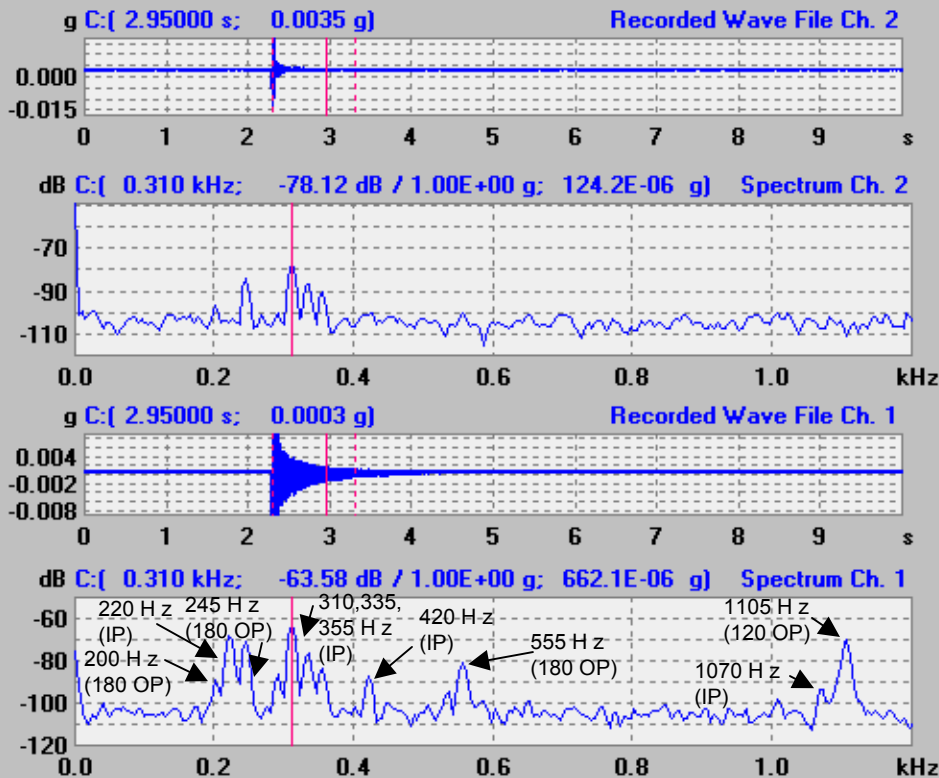

Second Vibration Test BOP Mode for Knorr Disc

- A BOP Natural Frequency For The Knorr Disc Was Difficult To Resolve Using The Accelerometers And Hammer As Described Above
- Field Data Indicated A BOP Frequency Of ~350 Hz
- A Second Method Of Investigating The BOP Frequency Was Used After Completion Of Phase 3 Testing

Vibration Test, Knorr Disc

- For This Test, The Strain Gages On Spokes 3 And 6 Of The Center Disc Of Test Axle 2 Were Used To Produce Signals For Analysis
- Test Axle 2 Was Still Installed In B-End Truck Under Coach Car 3534
- A Hammer Was Used To Excite The Disc
- Three Successive Hammer Blows, ~ 5 Seconds Apart, Were Applied To The Friction Ring At The Spoke 3 Position When Spoke 6 Was At The 2 O'Clock Position And Within The Pads
- Brakes Were Not Applied And Not Touching Disc

- The Resulting Ring Out Of The Spoke Strain Gage Signals Is Shown Below

Spoke 6, R1 Strain Gage Signal—Three Hammer Blows
CTR2SPK6R1 whole test three hits

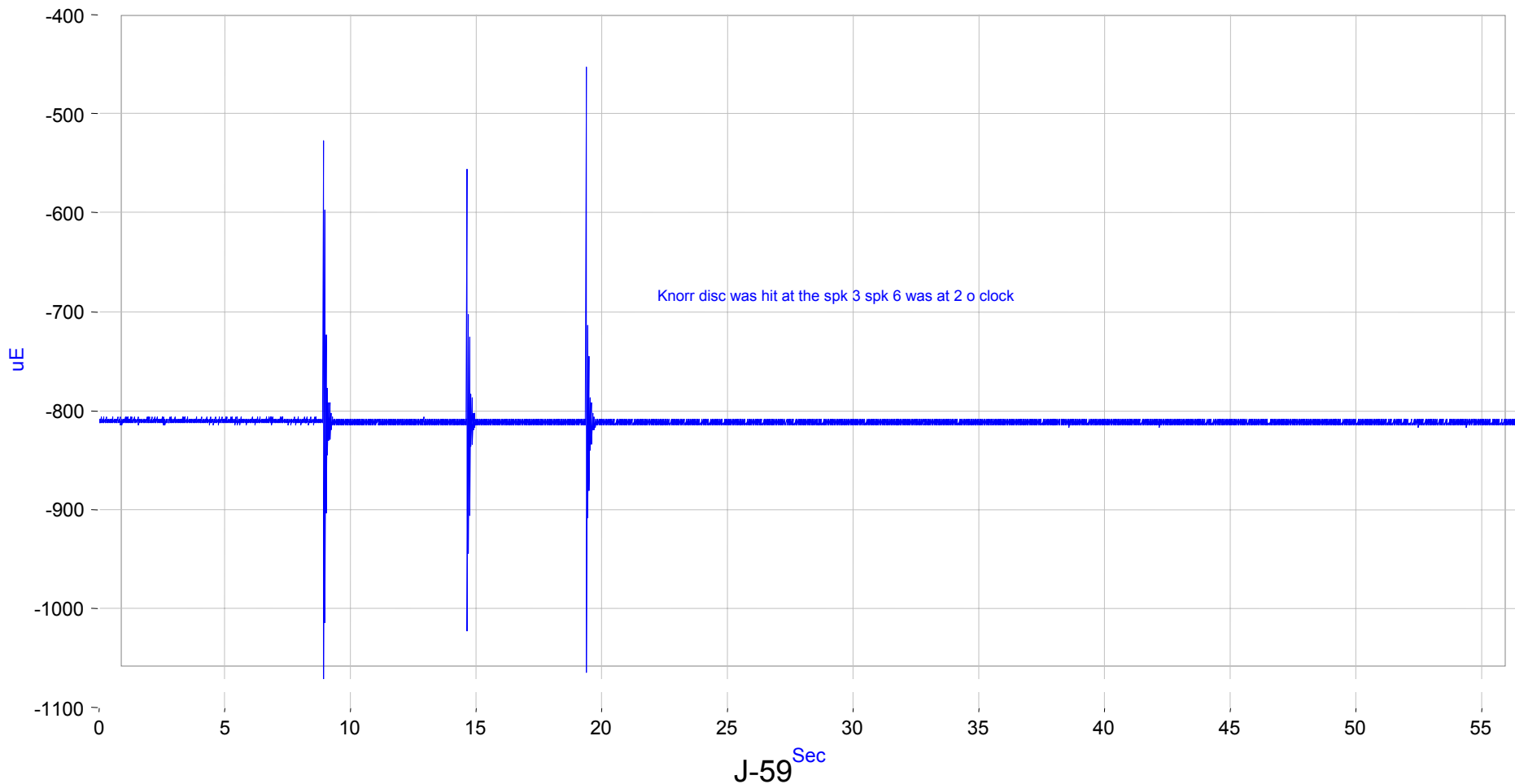

Spoke 3, R1 Strain Gage Signal—Three Hammer Blows

CTR2SPK3R1 whole test three hits

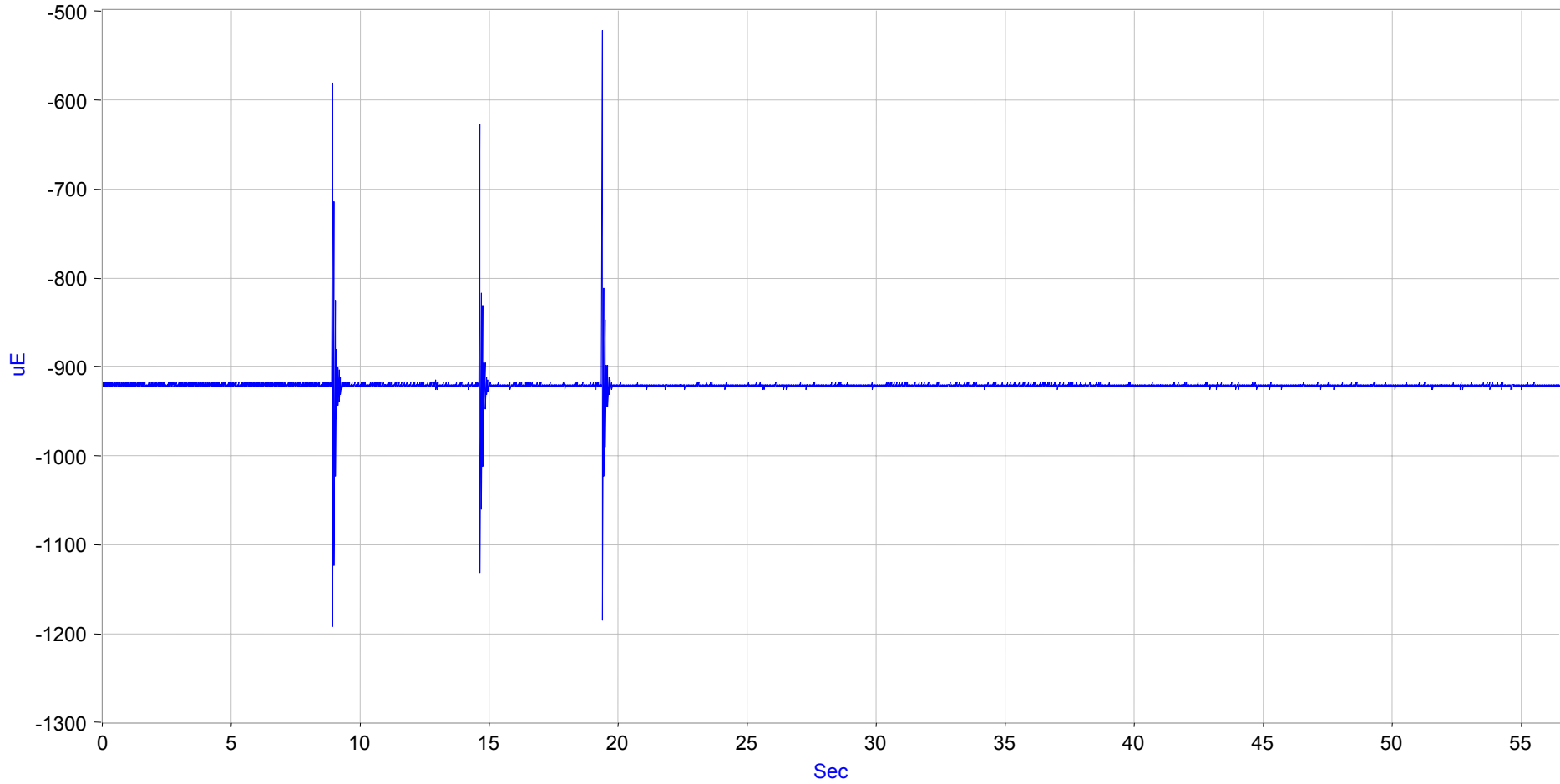

J-60

Spoke 6, R1 Strain Gage Signal After Third Hammer Blow

CTR2SPK6R1 third hit only

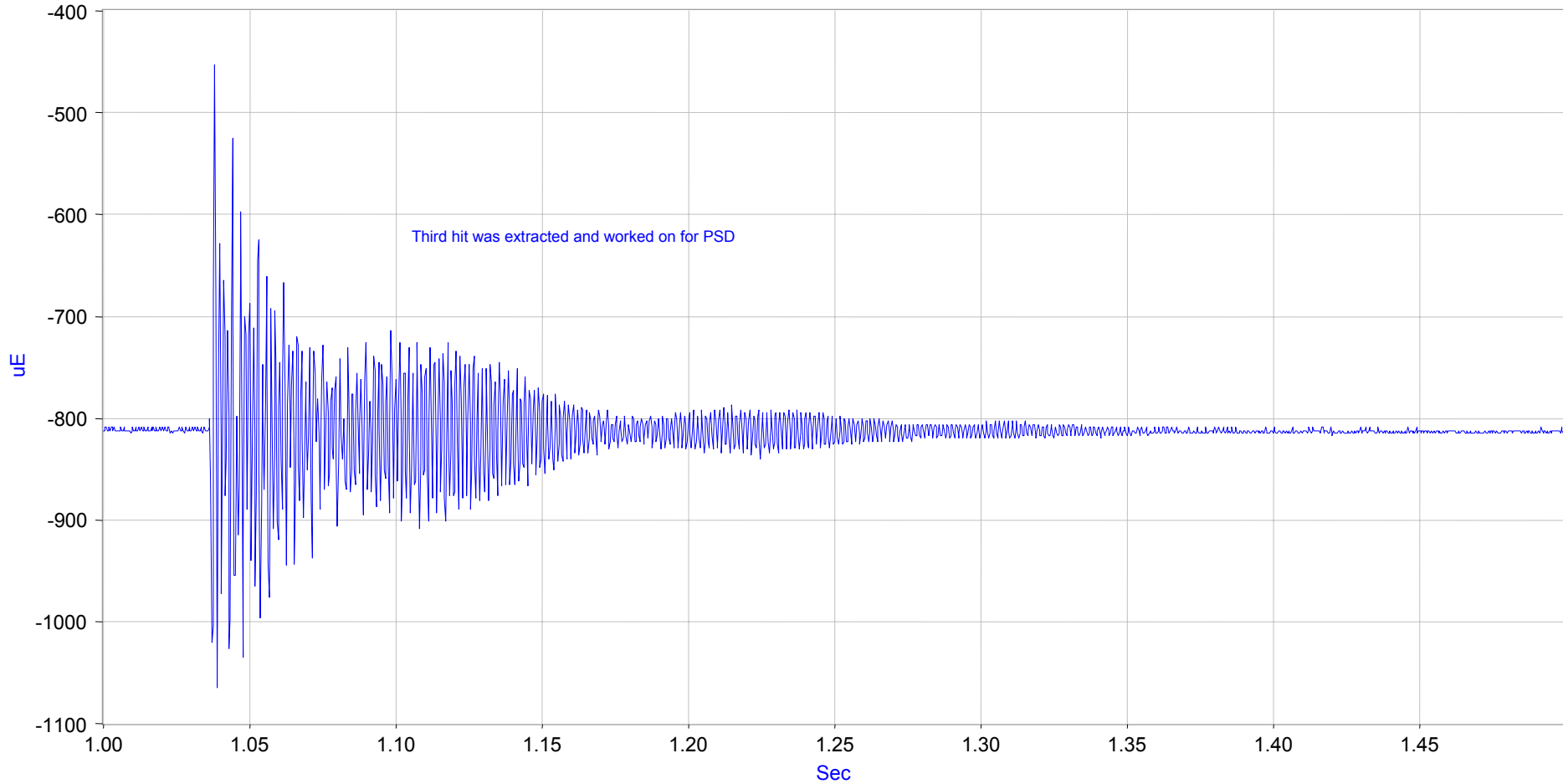

Spoke 6, R1 Strain Gage Signal, Mean Removed, After Third Hammer Blow

Mean removed CTR2SPK6R1 third hit only

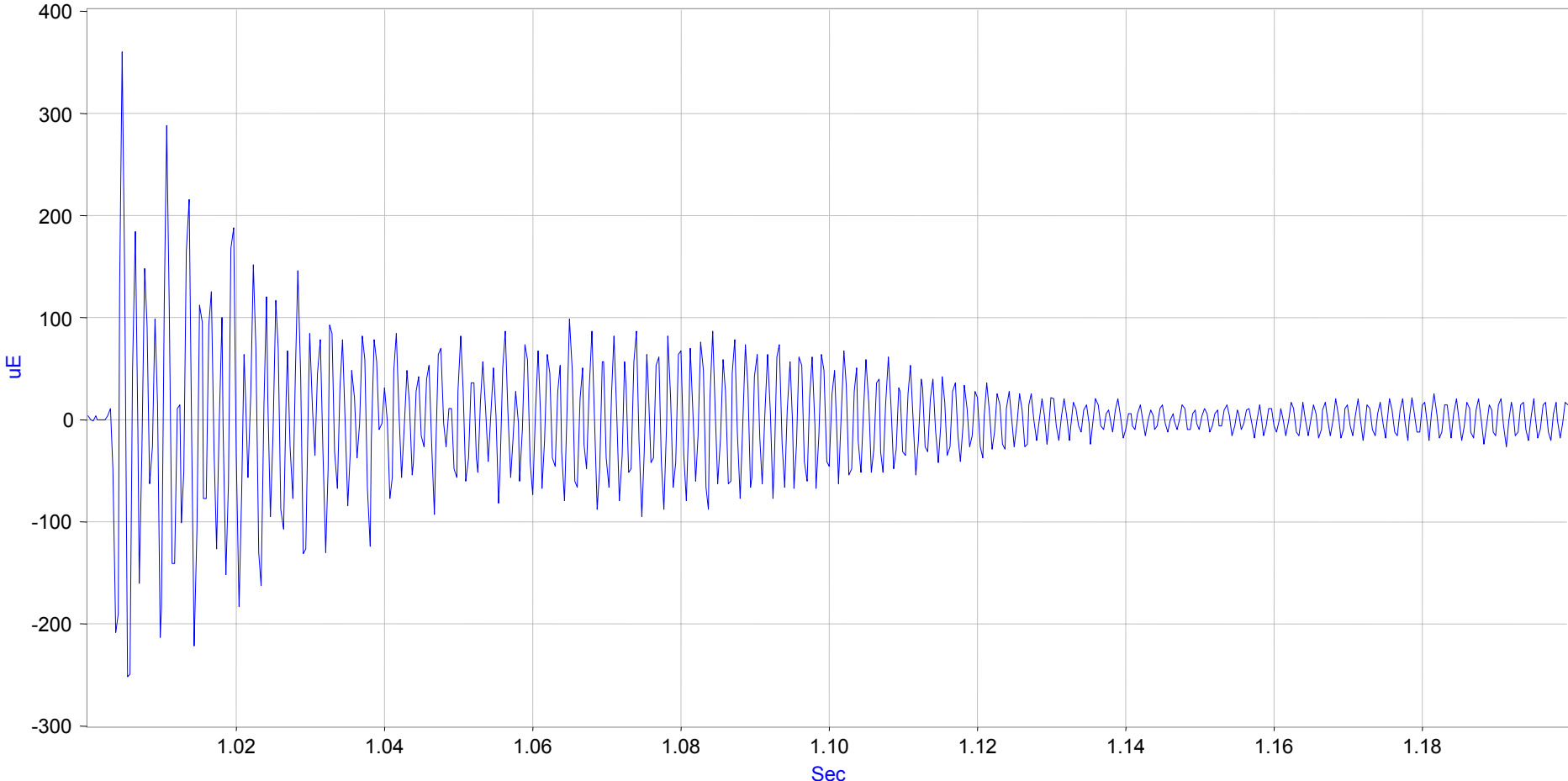

PSD Of Spoke 6, R1 Strain Gage Signal, Mean Removed, After Third Hammer Blow

PSD of the mean removed data

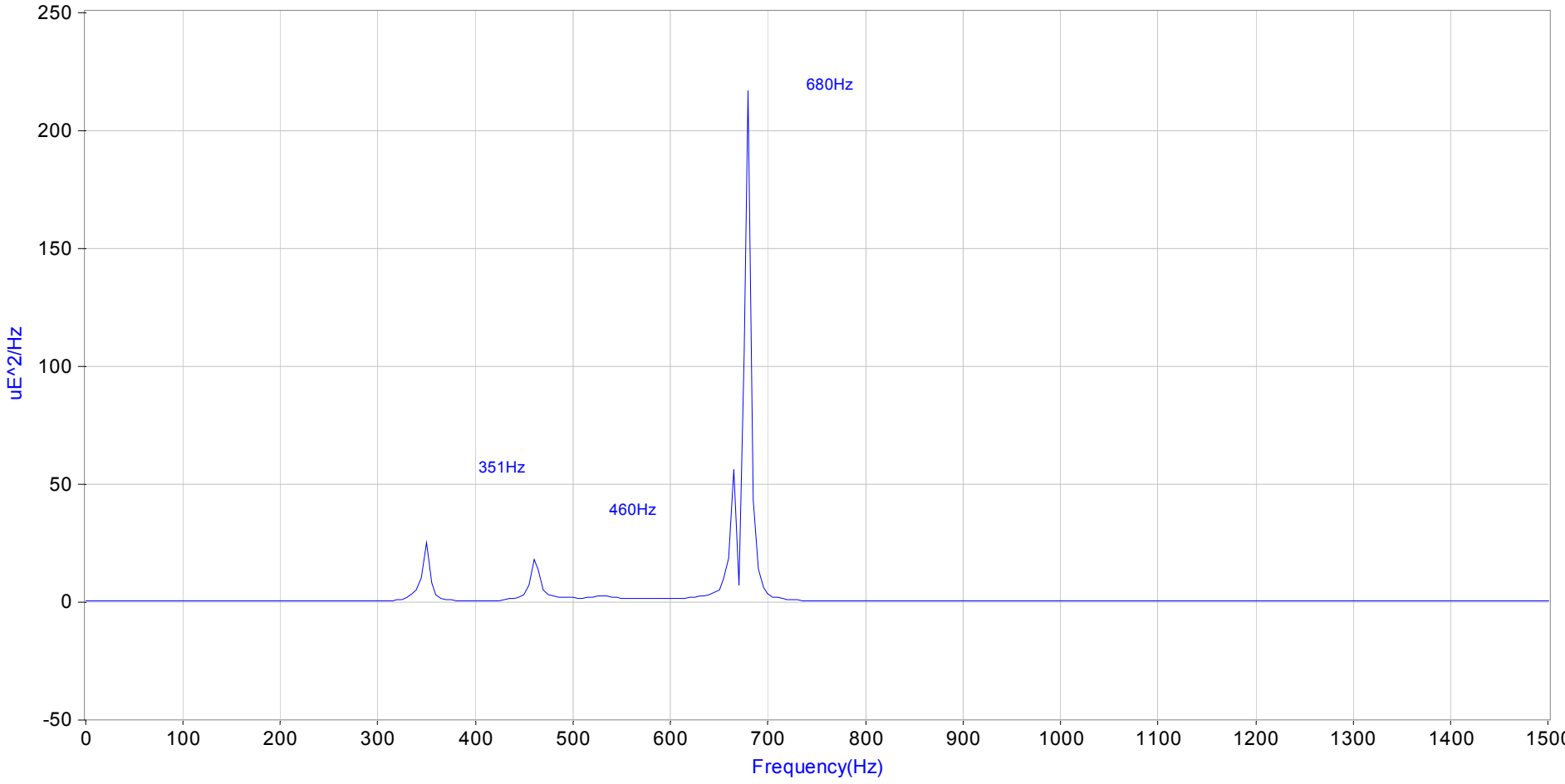

PSD (dB Scale) Of Spoke 6, R1 Strain Gage Signal, Mean Removed, After Third Hammer Blow

Log10(PSD)*10

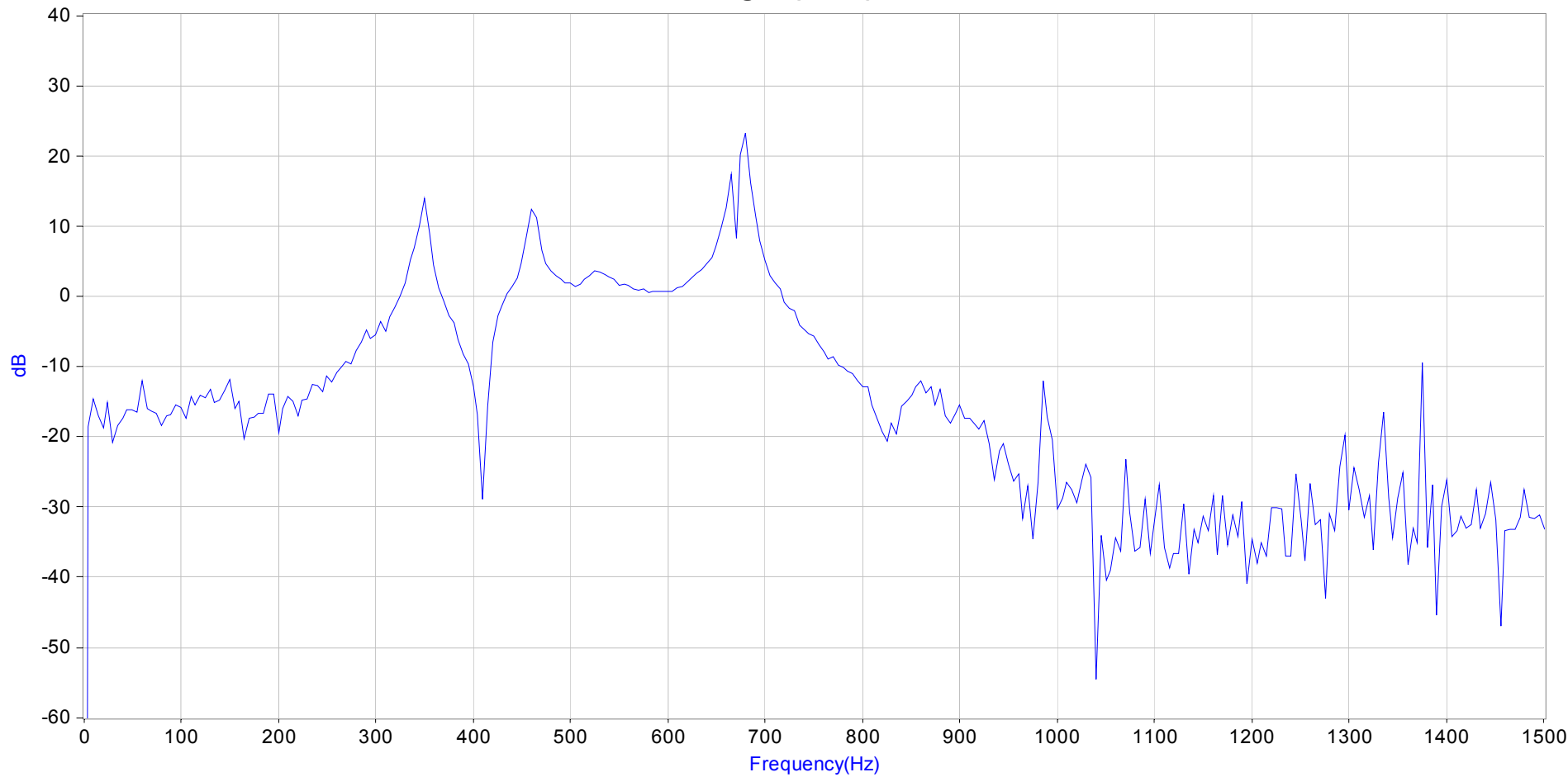

J-64

- A 4-Point Moving Average Filter Was Applied To Filter Out The Dominant 680 Hz Mode And Focus On The Lower Frequency Modes

Spoke 6, R1 Strain Gage Signal, 4-Point Moving Average–Three Hammer Blows
Moving Average of CTR2SPK6R1

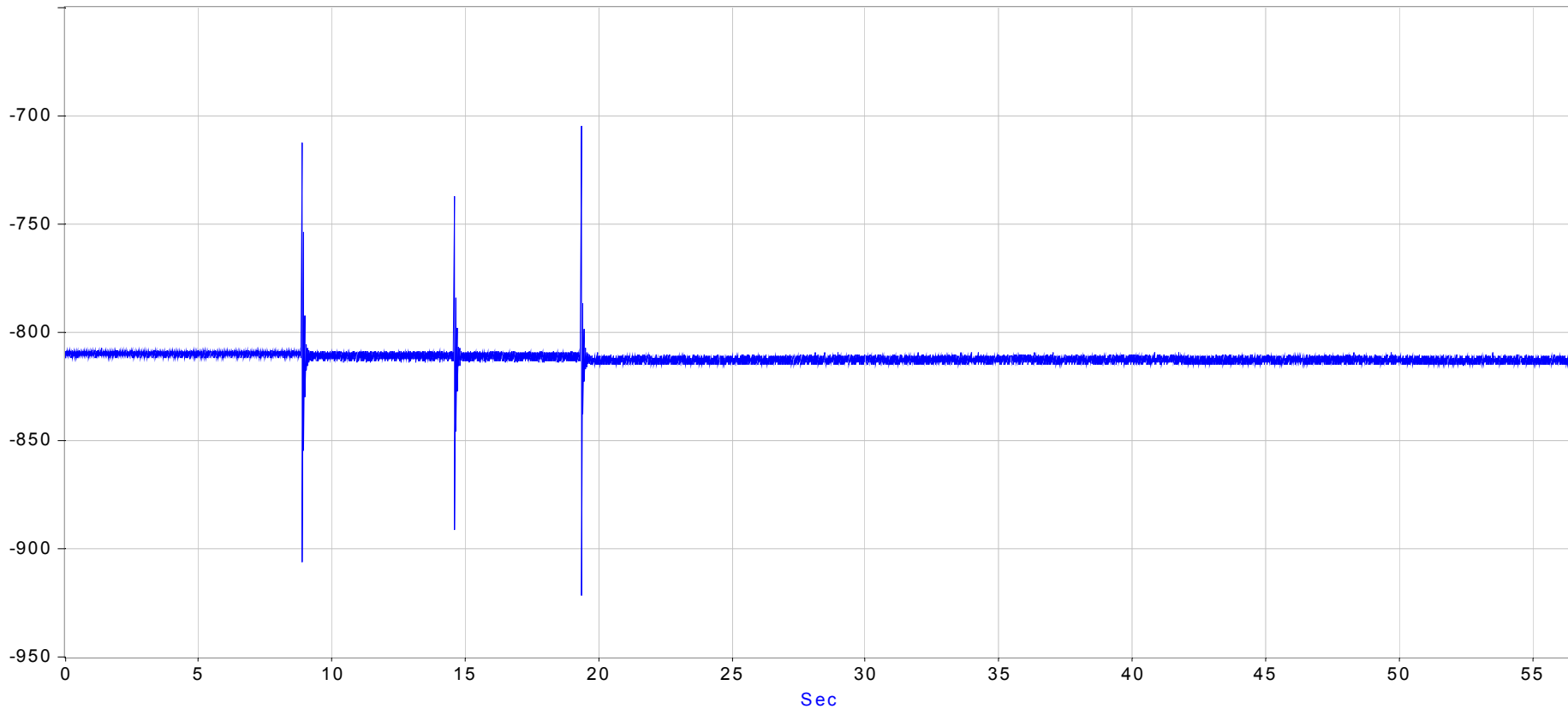

Spoke 3, R1 Strain Gage Signal, 4-Point Moving Average–Three Hammer Blows

Moving Avg of CTR2SPK3R1

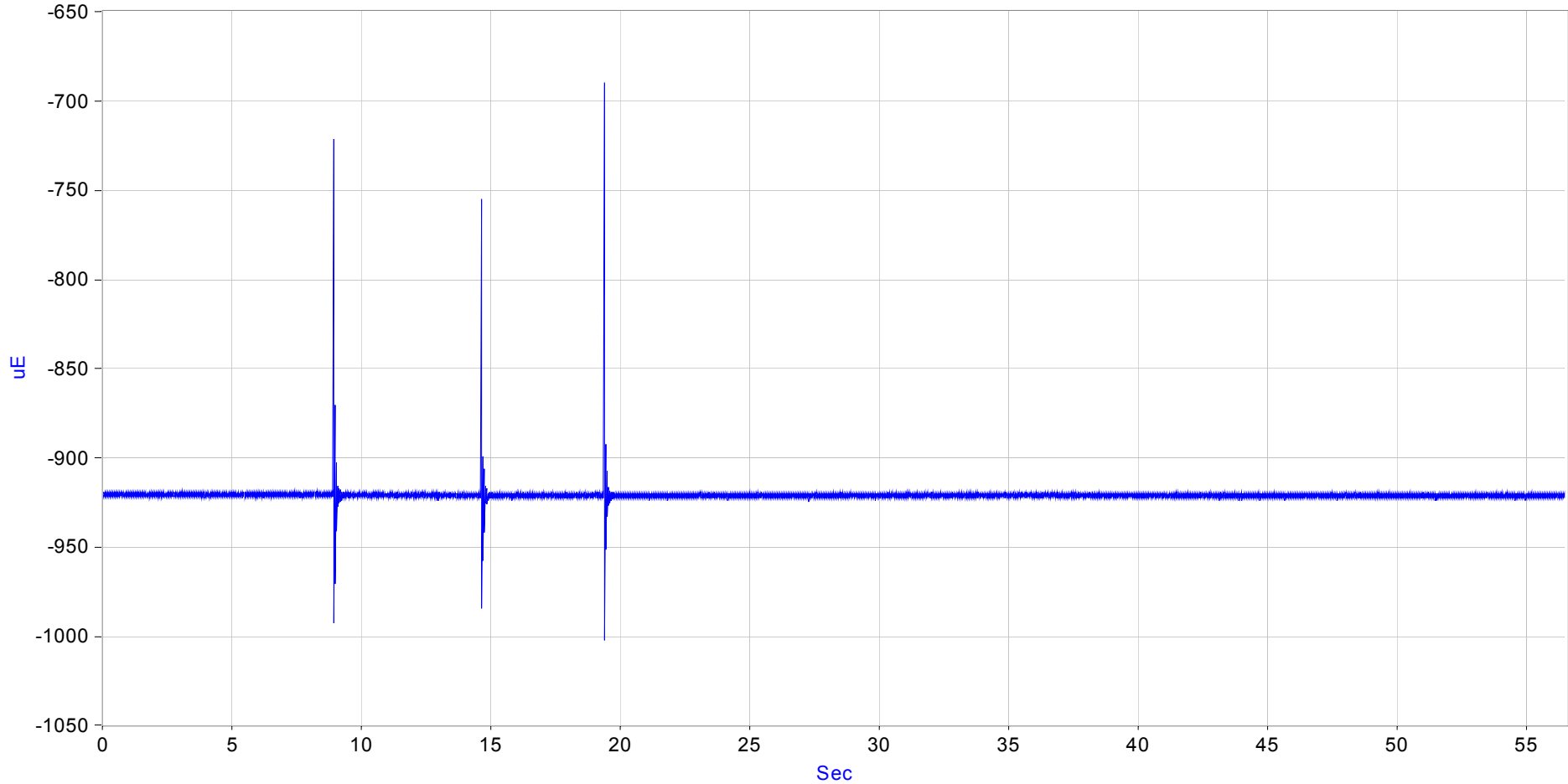

J-66

Spoke 6, R1 Strain Gage Signal, 4-Point Moving Average, After Third Hammer Blow

CTR2SPK6R1 filtered third hit only

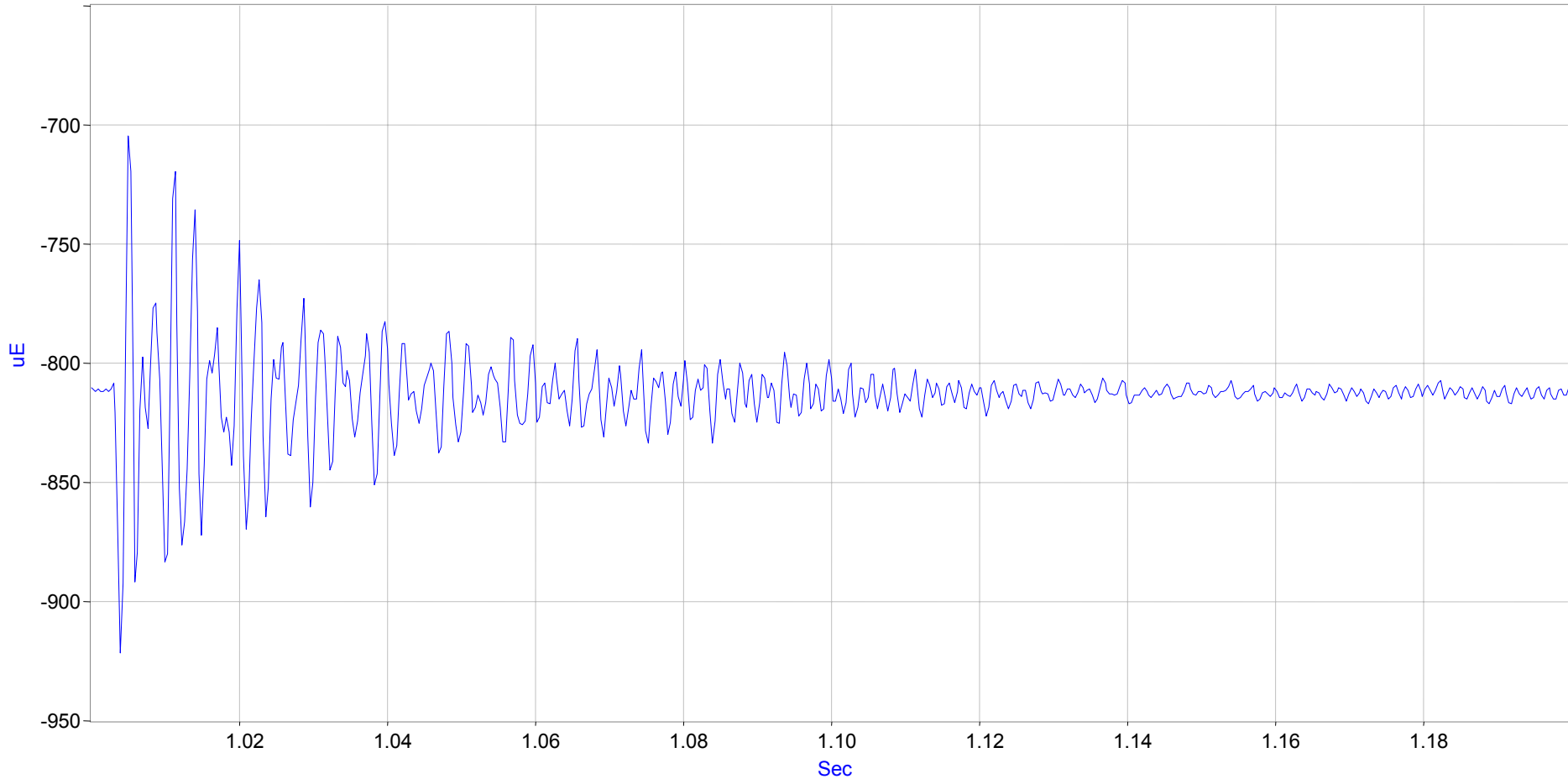

J-67

PSD of Spoke 6, R1 Strain Gage Signal, 4-Point Moving Average, After Third Hammer Blow

PSD of the filtered data CTR2SPK6R1

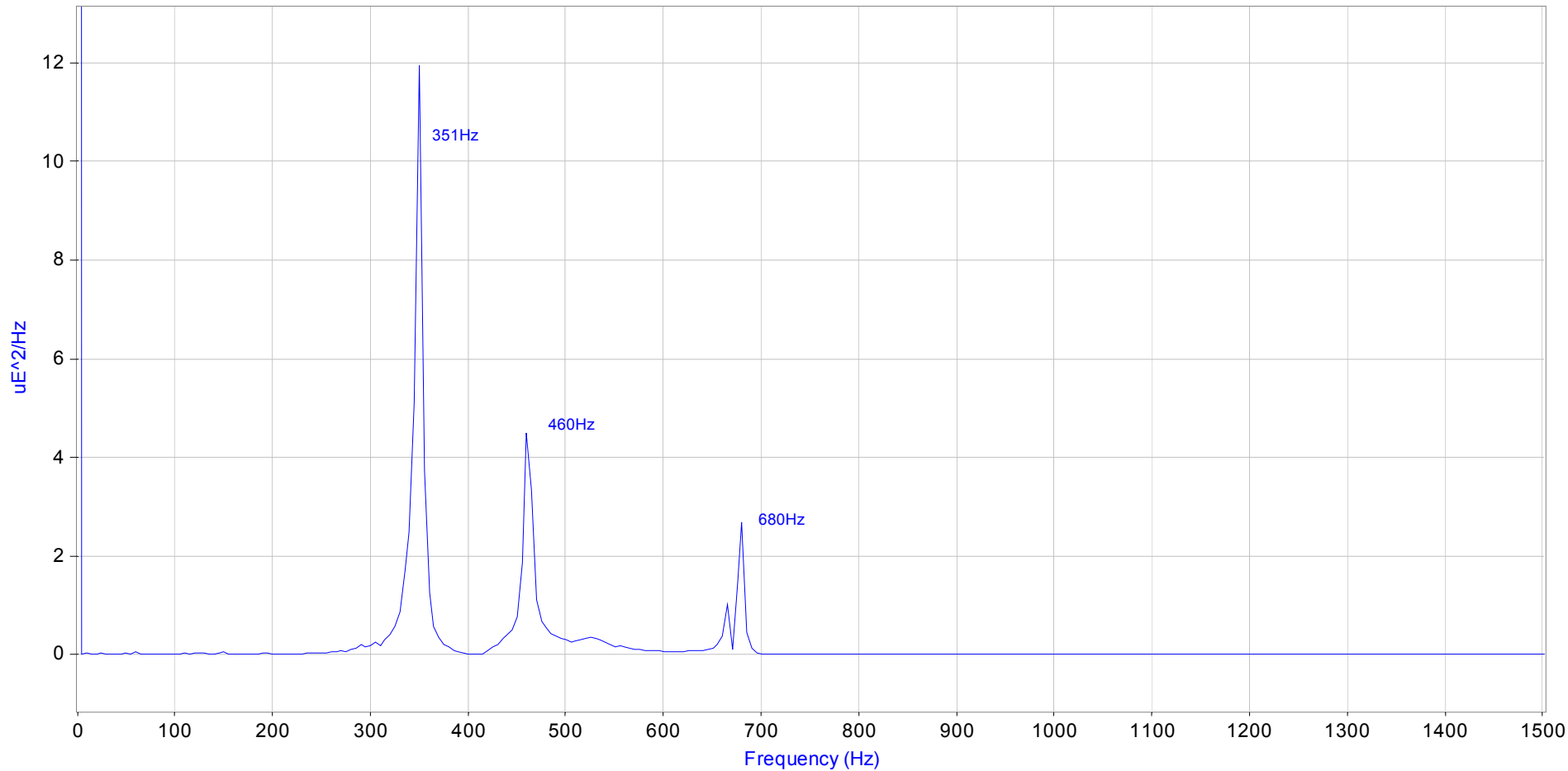

- The Knorr Disc Has A BOP Frequency At 350 Hz

PSD (dB Scale) of Spoke 6, R1 Strain Gage Signal, 4-Point Moving Average, After Third Hammer Blow

Log10(PSD)*10

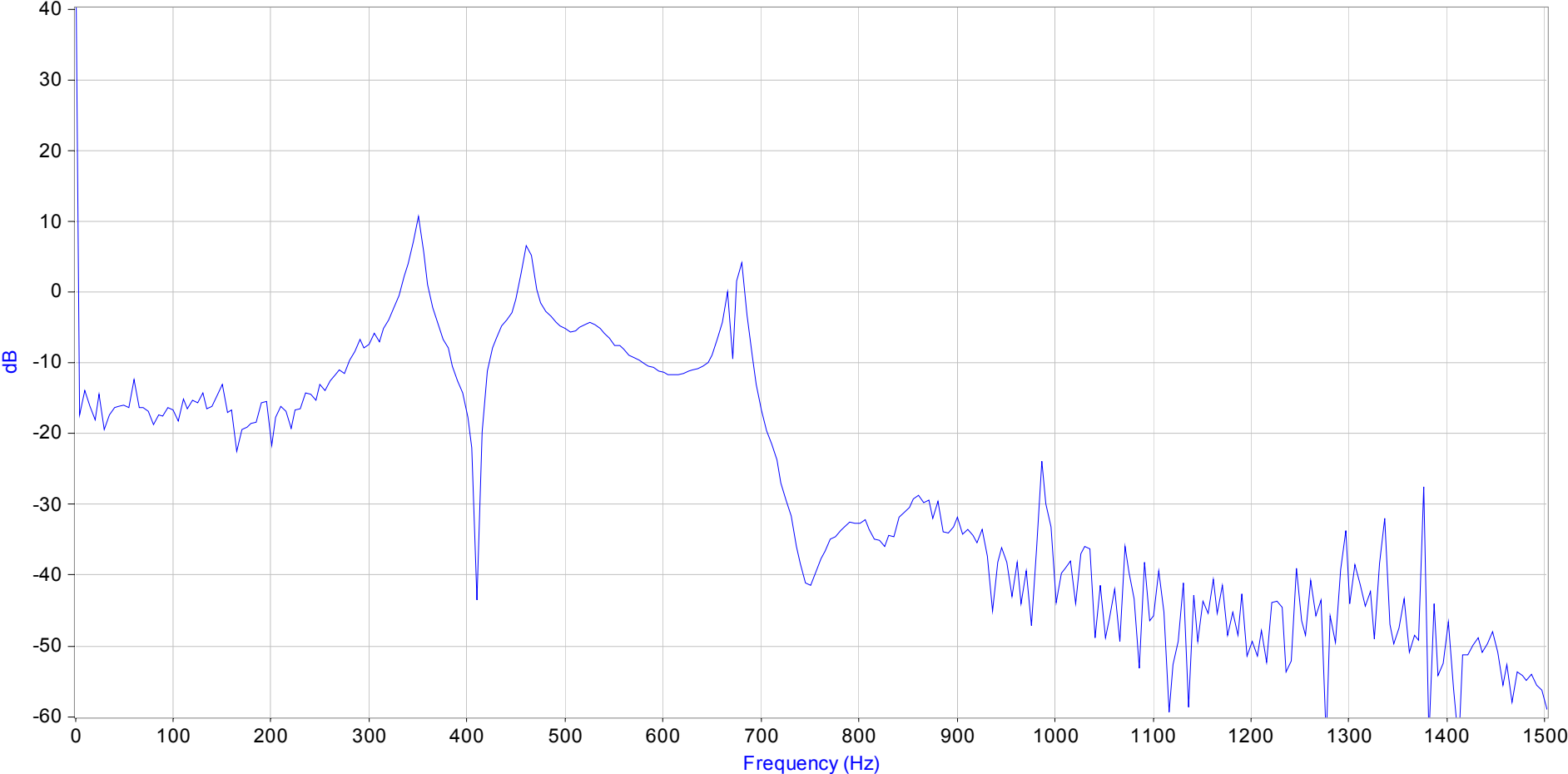

Comparison Of The Two PSDs–Non Filtered (Blue) And Filtered (Green)

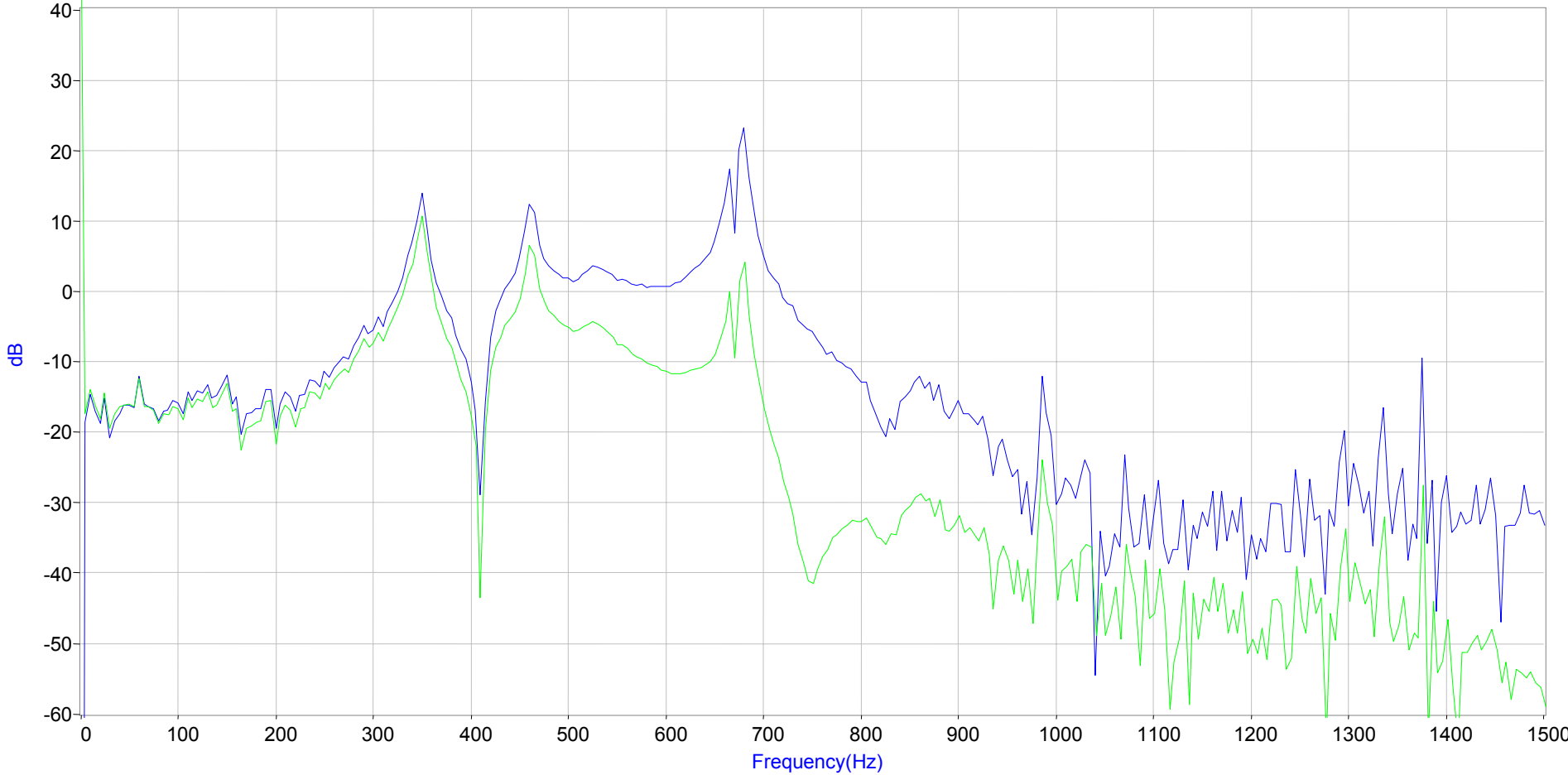

J-70

Demeaned And Filtered CTR2SPK6R1 And CTR2SPK3R1

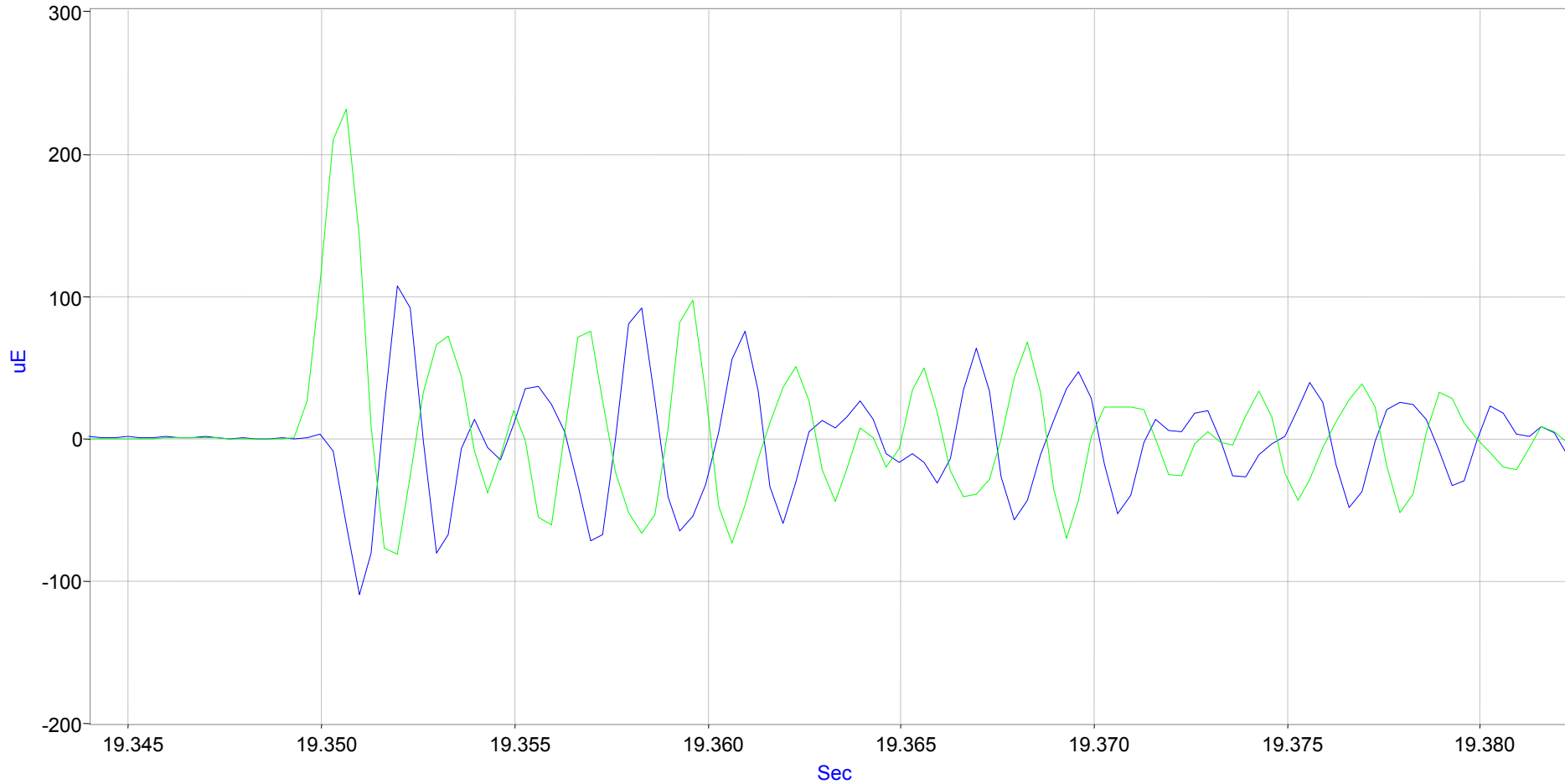

- The Oscillations Seen On Spokes 3 And 6 Are Out Of Phase With Respect To Each Other

Appendix K. Brake Support Links

<u>Section</u>	<u>Page</u>
Link Descriptions	K-2
Examples of Link Behavior	K-8
June 16–File 18, Braking, No Sustained Oscillations, Axle Trailing	K-11
June 18–File 24, Braking, No Sustained Oscillations, Instrumented Axle in Lead	K-20
June 18–File 24, Braking, Sustained Oscillations, Instrumented Axle in Lead	K-29
June 17–File 25, Braking Sustained Oscillation, Instrumented Axle in Lead	K-42
Observations	K-54

Link Descriptions

Brake Caliper Support Links

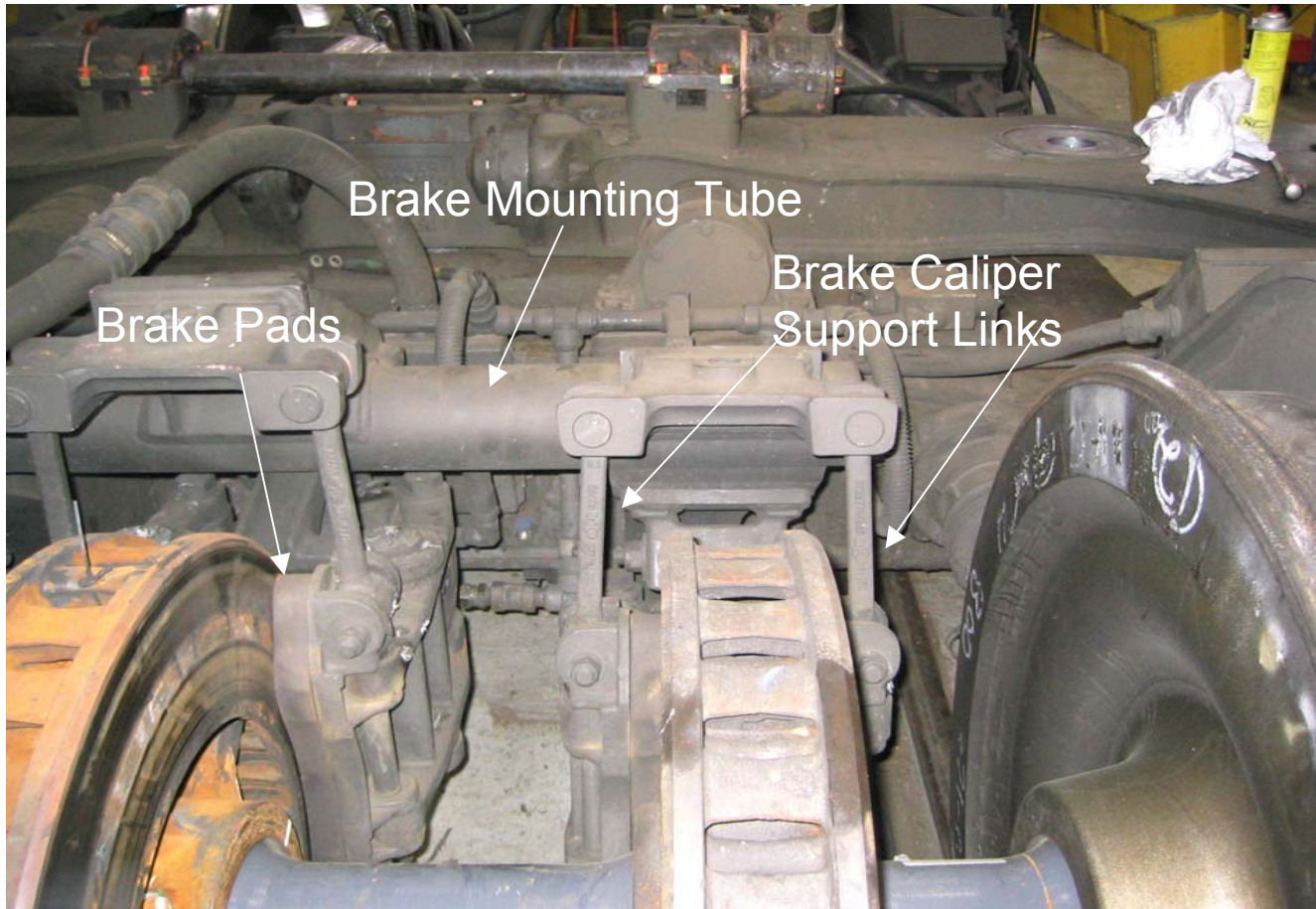

Gage Location

- 3 Inches Down From Top
- Face Inside—Towards Center Of Truck

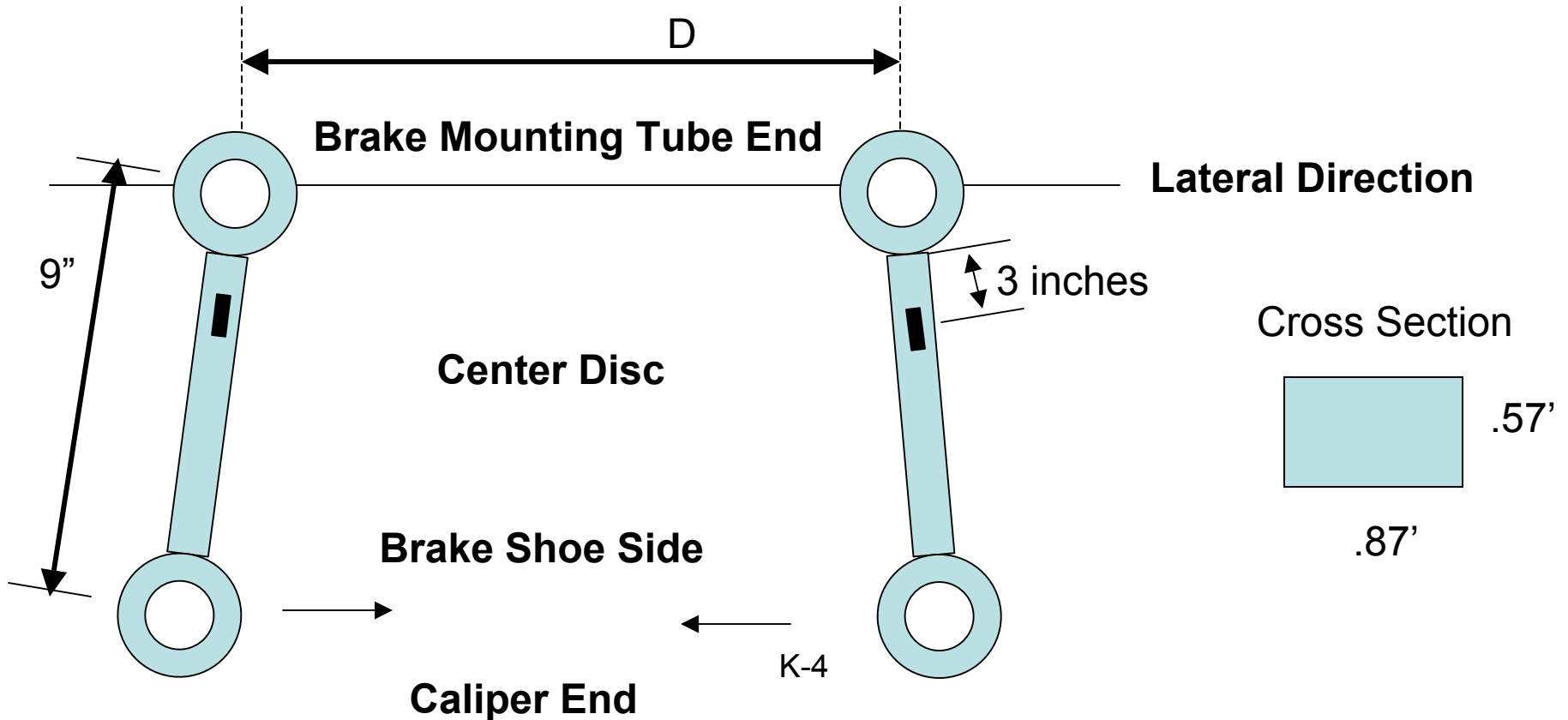

Force Versus Strain In Brake Link

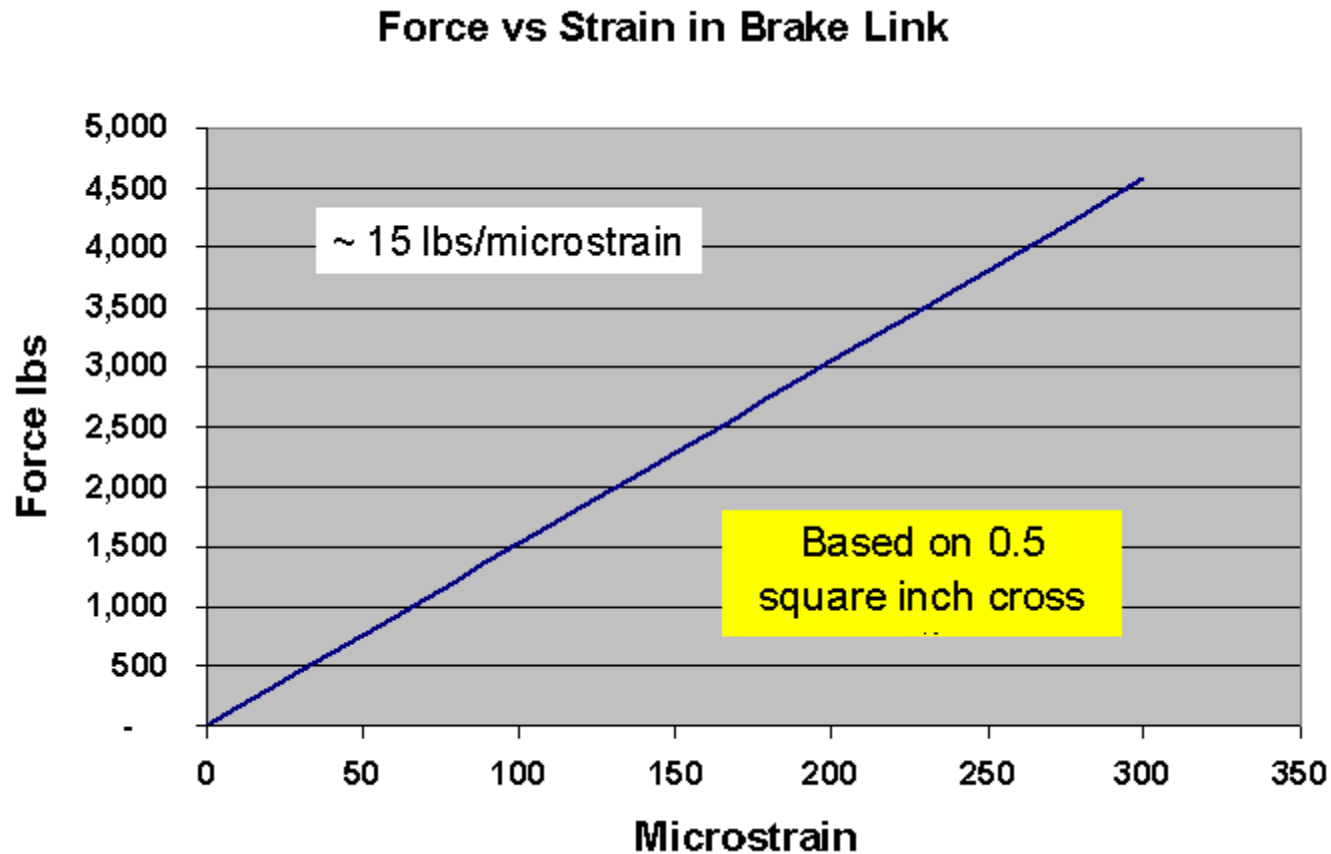

Expected Behavior

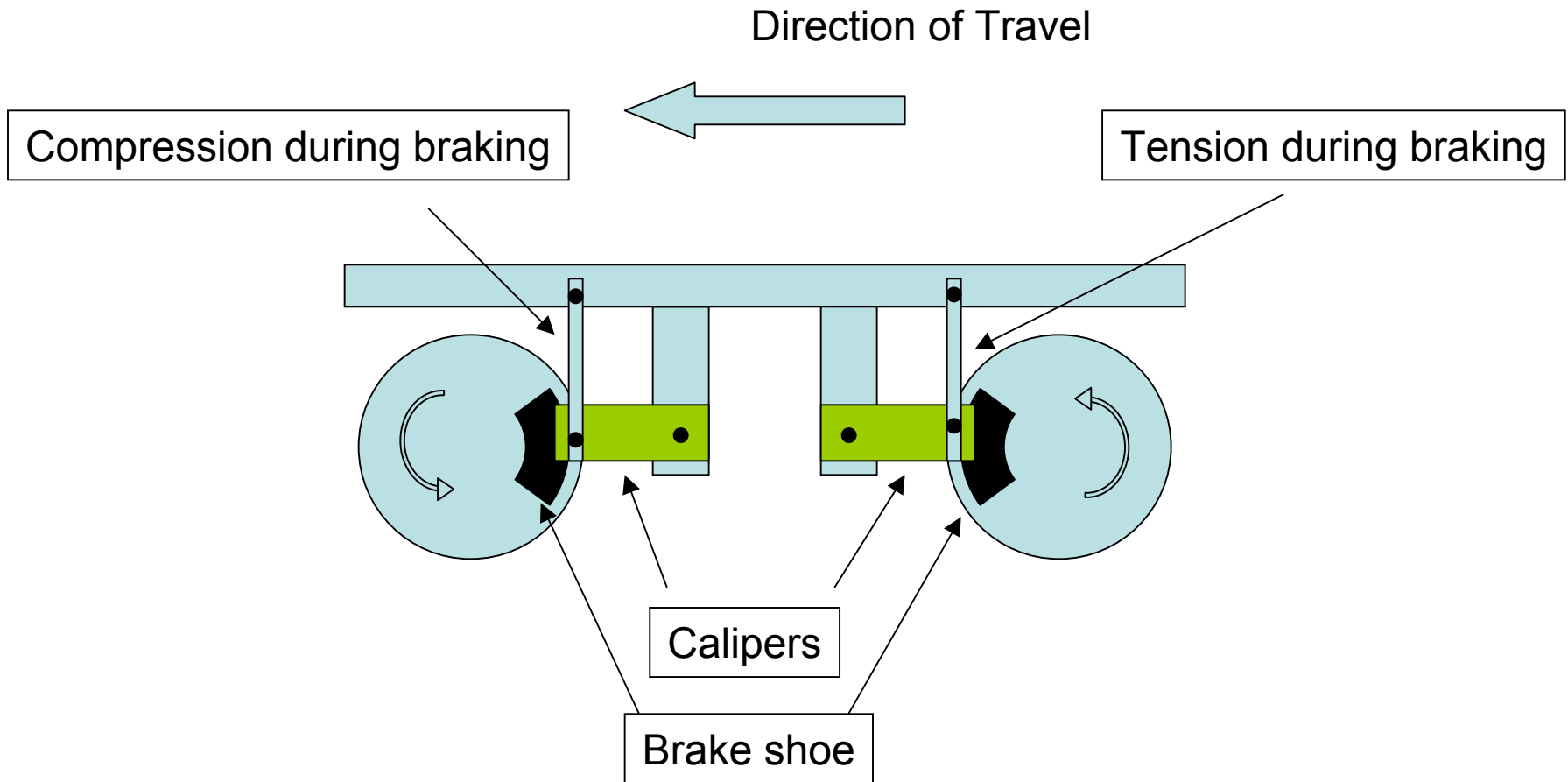

Major Assumption

- The Strain Measured By The Single Strain On The Link Is A Good Indication Of Strain In Link
- Should Be A Good Assumption Since The Link Is Pinned At Both Ends

Examples Of Link Behavior

Data Selection

- All Under Braking Condition
- Brake Cylinder Pressure ~ 50 psi
- Instrumented Axle In Lead Position
 - During Sustained Oscillations
 - During Non-Sustained Oscillations
- Instrumented Axle In Trail Position
 - During Non-Sustained Oscillations

Table K.1. Examples Analyzed

Date/File	Sustained Oscillation	Axle	Time in File (sec.)	Speed (mph)
June 16–File 18	No	Trail	375	94
June 18–File 24	No	Lead	310	117
June 18–File 24	Yes	Lead	580	110
June 17–File 25	Yes	Lead	559	69

June 16–File 18
Braking
No Sustained Oscillations
Axle Trailing
 $t = 375$ seconds
Speed = 94 mph

June 16–File 18–375 Seconds Braking, No Sustained Oscillations And Axle Trailing

WABTEC/SAB-WABCO Disc Brake Cylinder Pressure

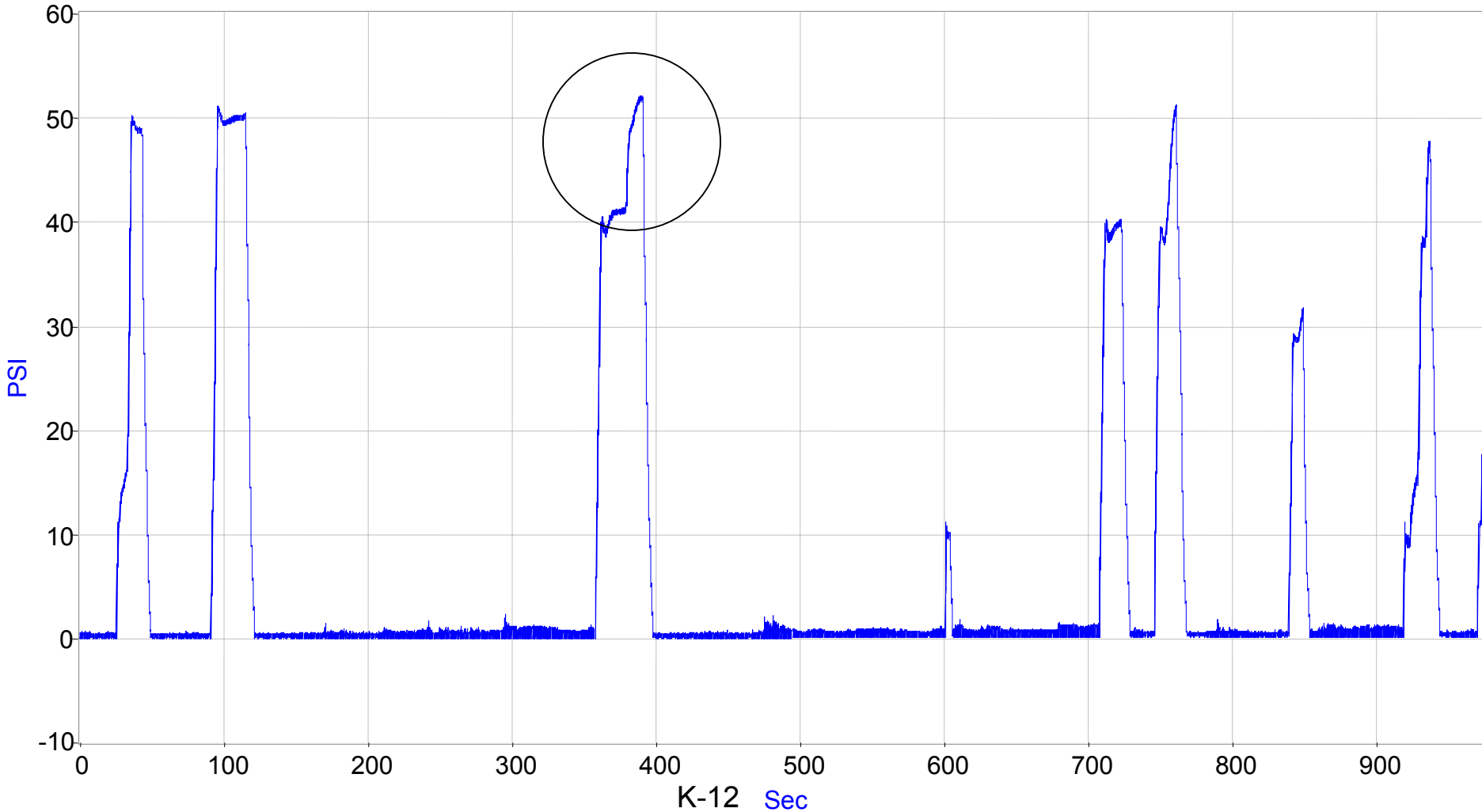

June 16–File 18–375 Seconds

Braking, No Sustained Oscillations And Axle Trailing

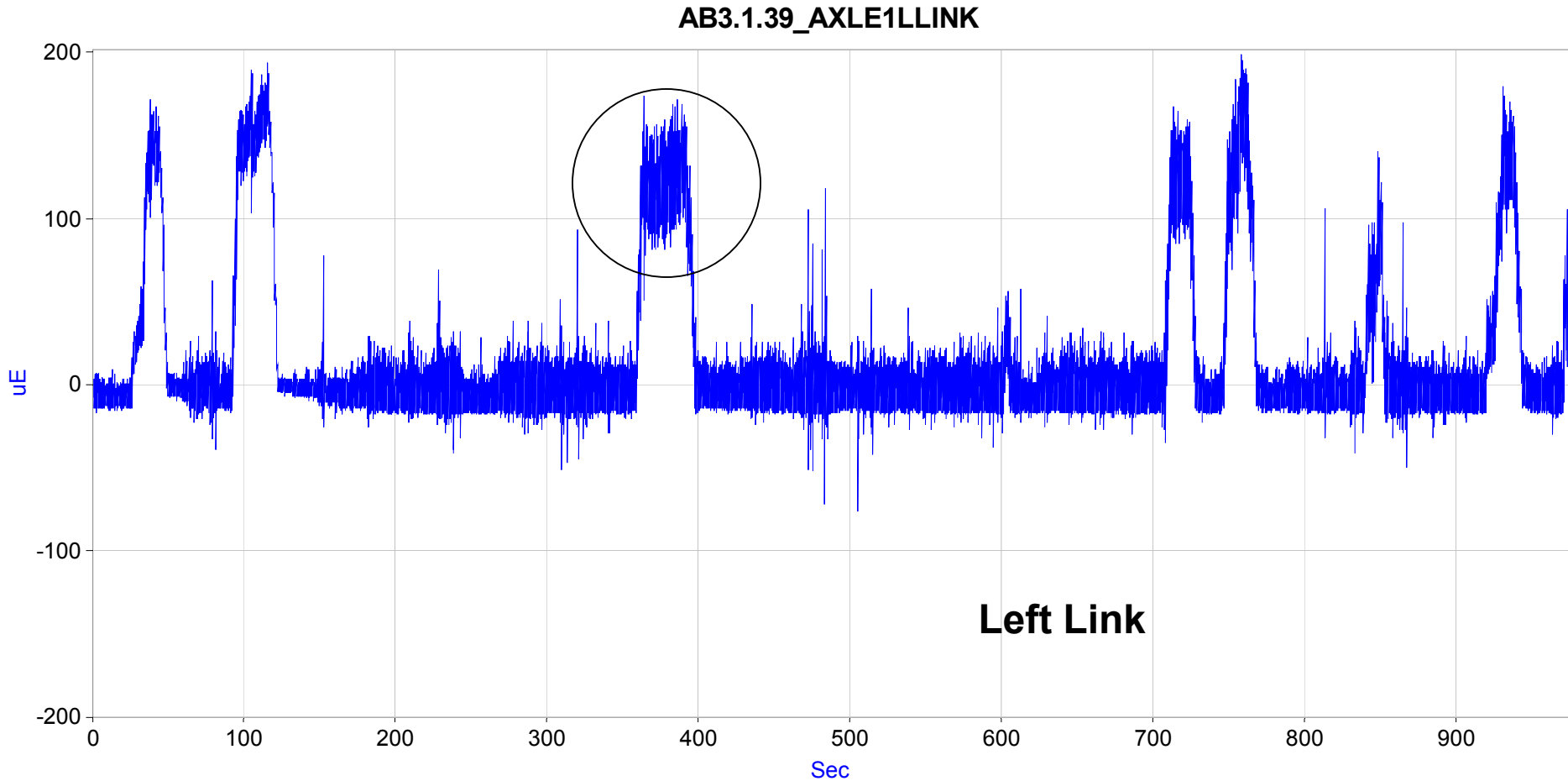

June 16–File 18–375 Seconds

Braking, No Sustained Oscillations And Axle Trailing

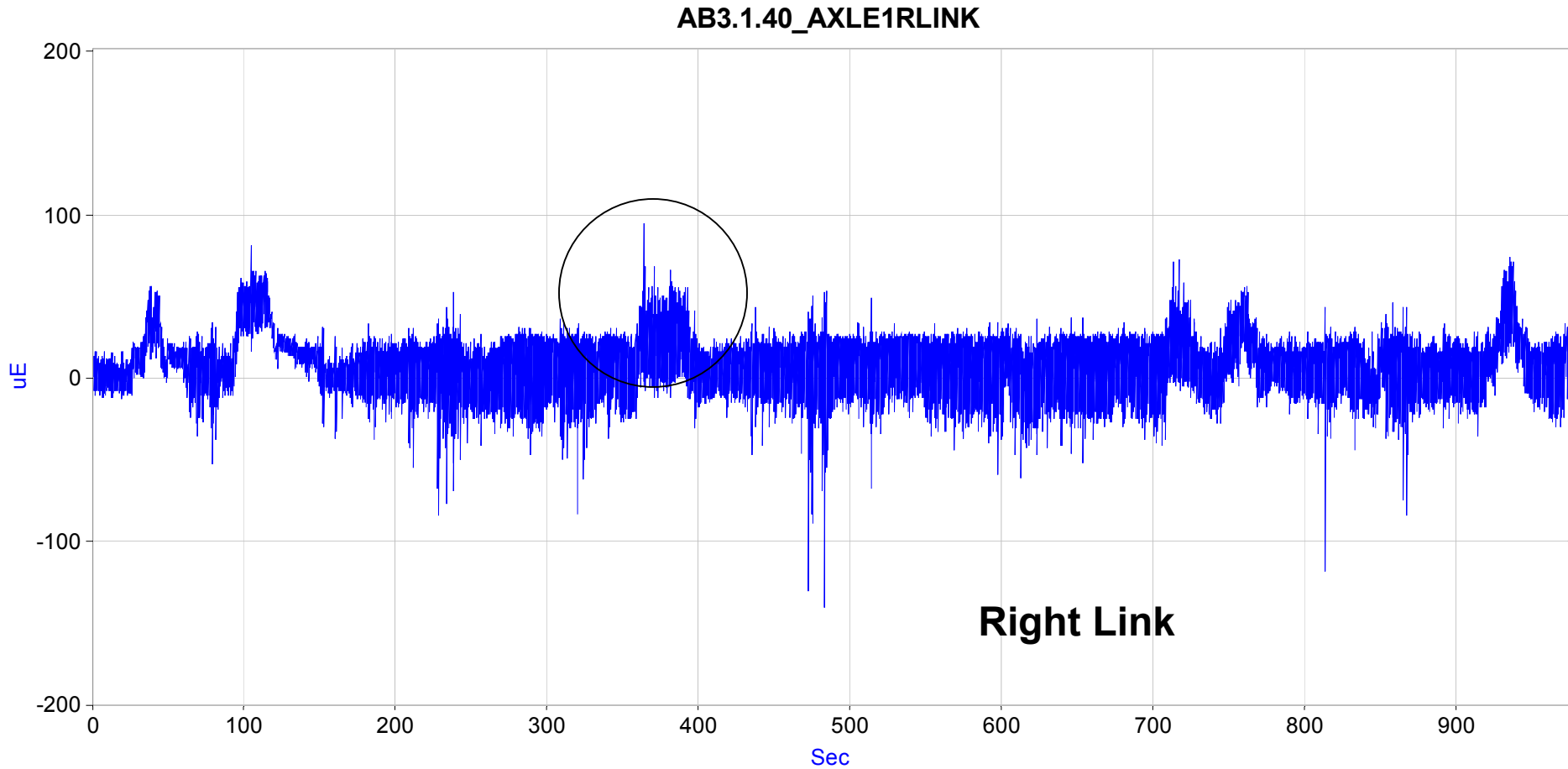

K-14

June 16–File 18–375 Seconds

Braking, No Sustained Oscillations And Axle Trailing

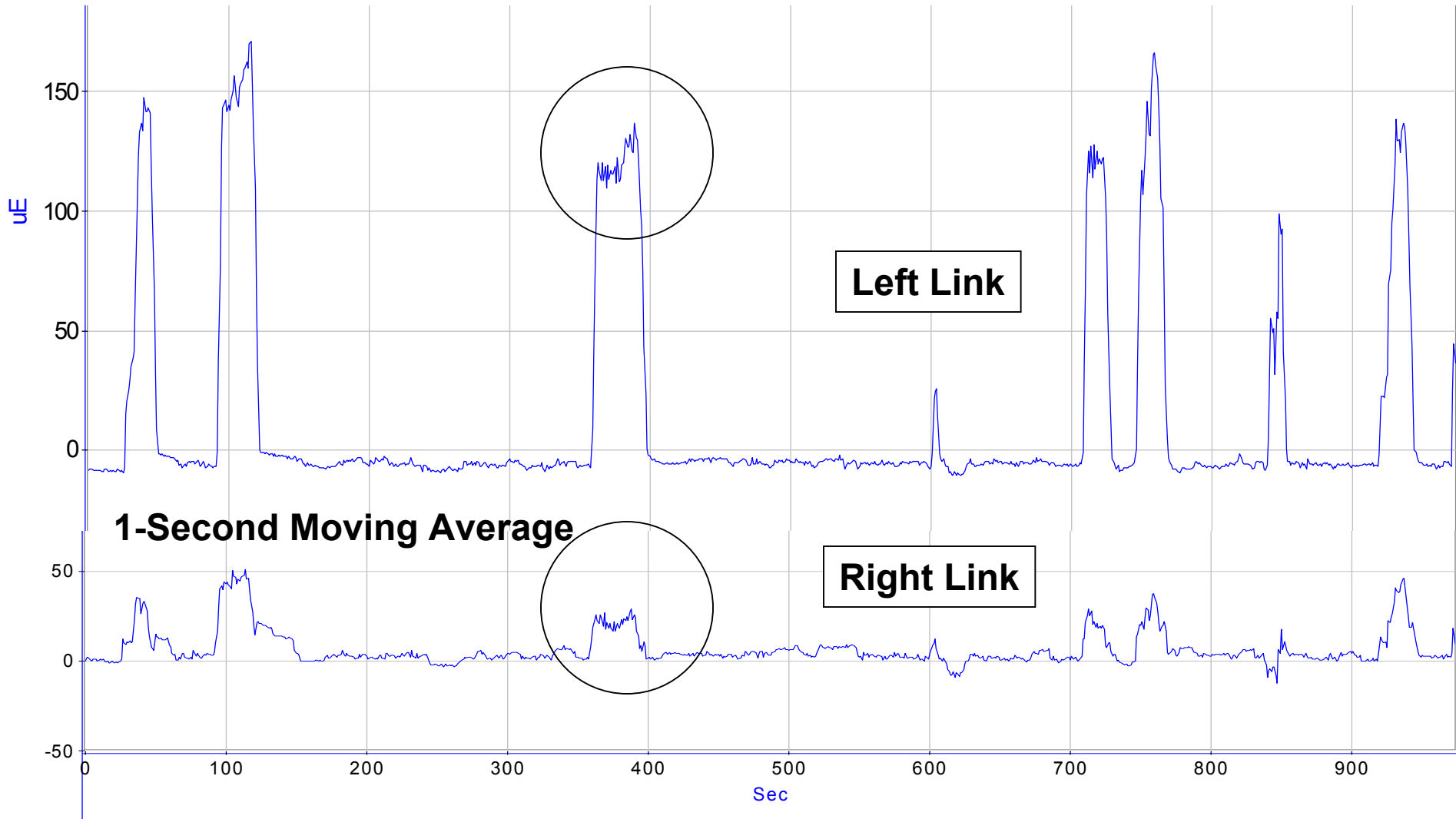

K-15

June 16–File 18–375 Seconds

Braking, No Sustained Oscillations And Axle Trailing

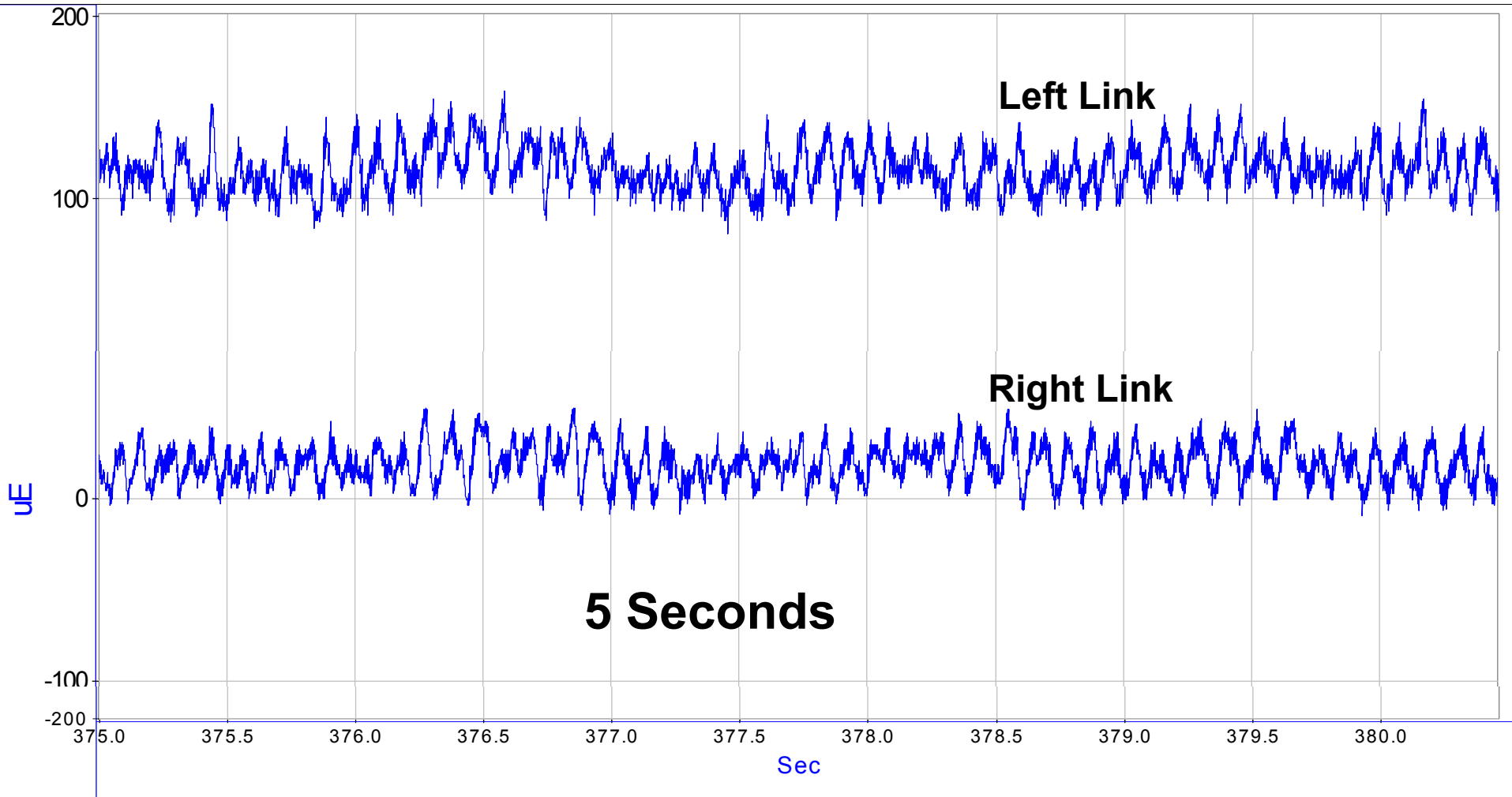

K-16

June 16–File 18–375 Seconds

Braking, No Sustained Oscillations And Axle Trailing

PSD of WABTEC/SAB-WABCO Disc, Left Link Strain, 16384 points, 5 point moving avg

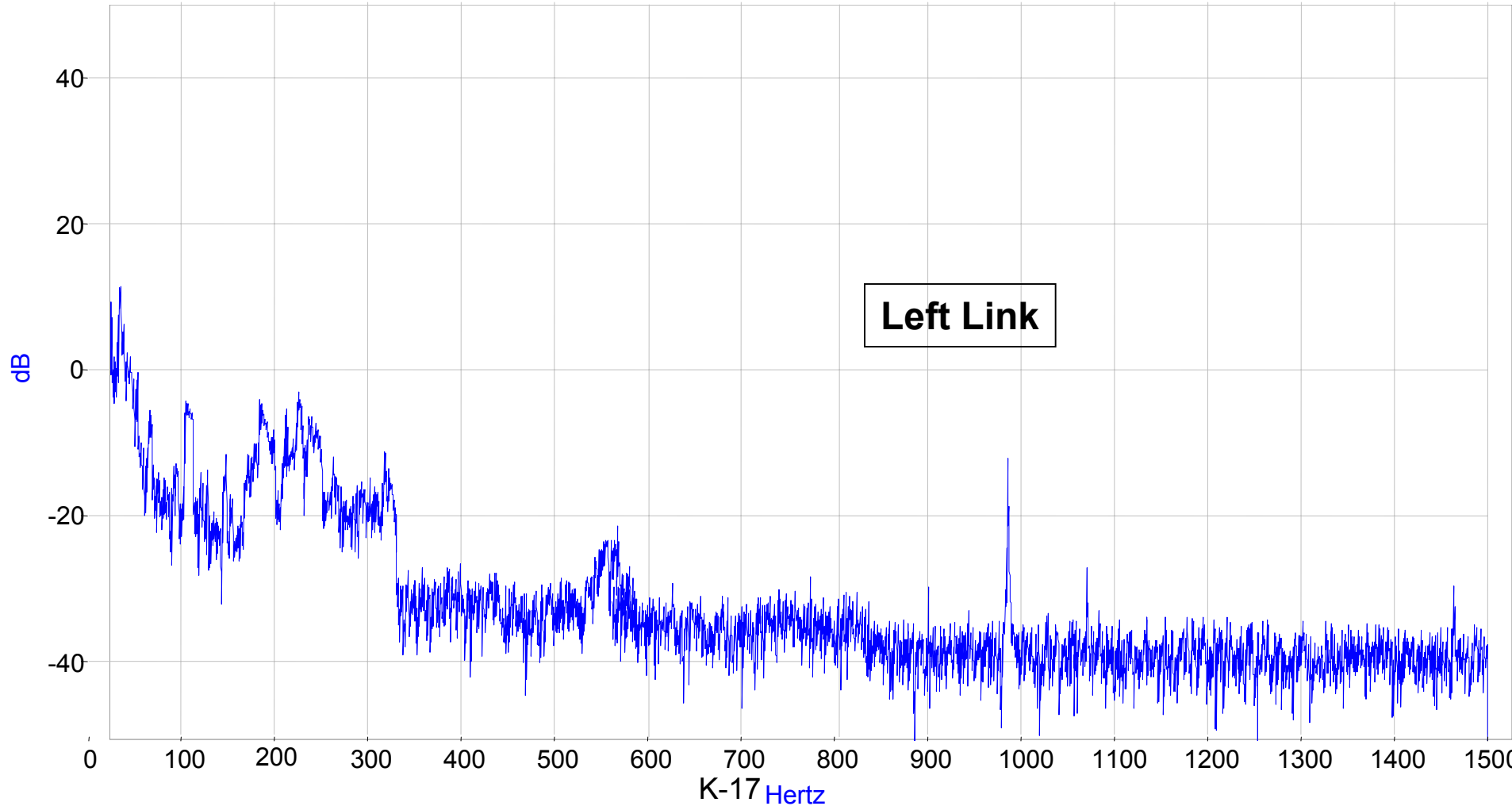

June 16–File 18–375 Seconds

Braking, No Sustained Oscillations And Axle Trailing

PSD of WABTEC/SAB-WABCO Disc, Right Link Strain, 16384 points, 5 point moving avg

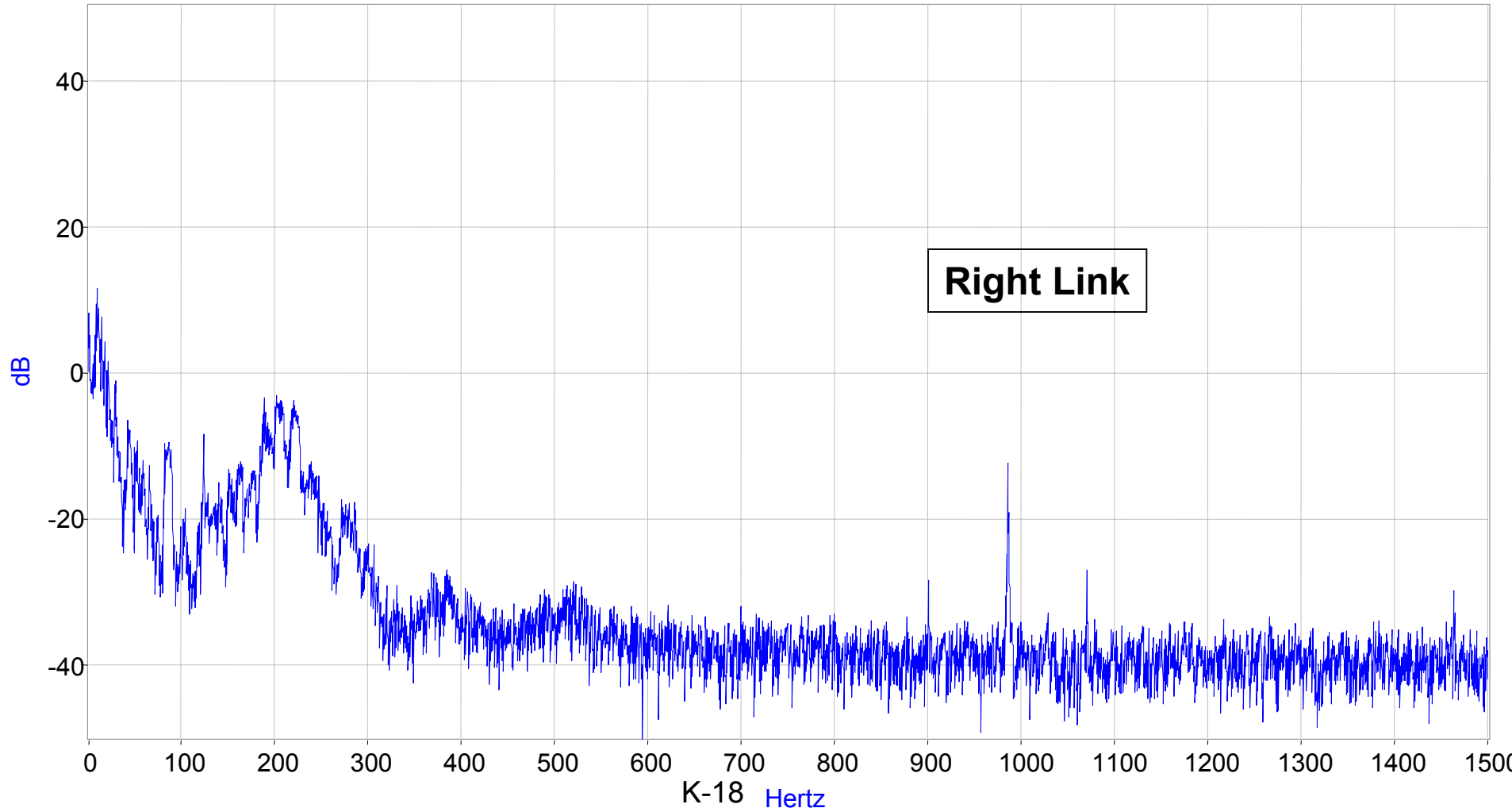

June 16–File 18–375 Seconds

Braking, No Sustained Oscillations And Axle Trailing

Date/File/Time	Sustained Oscillation	Axle	Harmonic Content	Strain Change
June 16 – File 18 - 375	No	Trail	No	Tension

Date/File/Time	Sustained Oscillation	Axle	Left Link Microstrain	Right Link Microstrain
June 16 – File 18 - 375	No	Trail	+130	+21

June 18–File 24 Braking
No Sustained Oscillations
Instrumented Axle In Lead
t = 310 Seconds
Speed = 117 mph

June 18–File 24–310 Seconds Braking, No Sustained Oscillations Instrumented Axle In Lead

AB3.1.13_CYLPRESS1

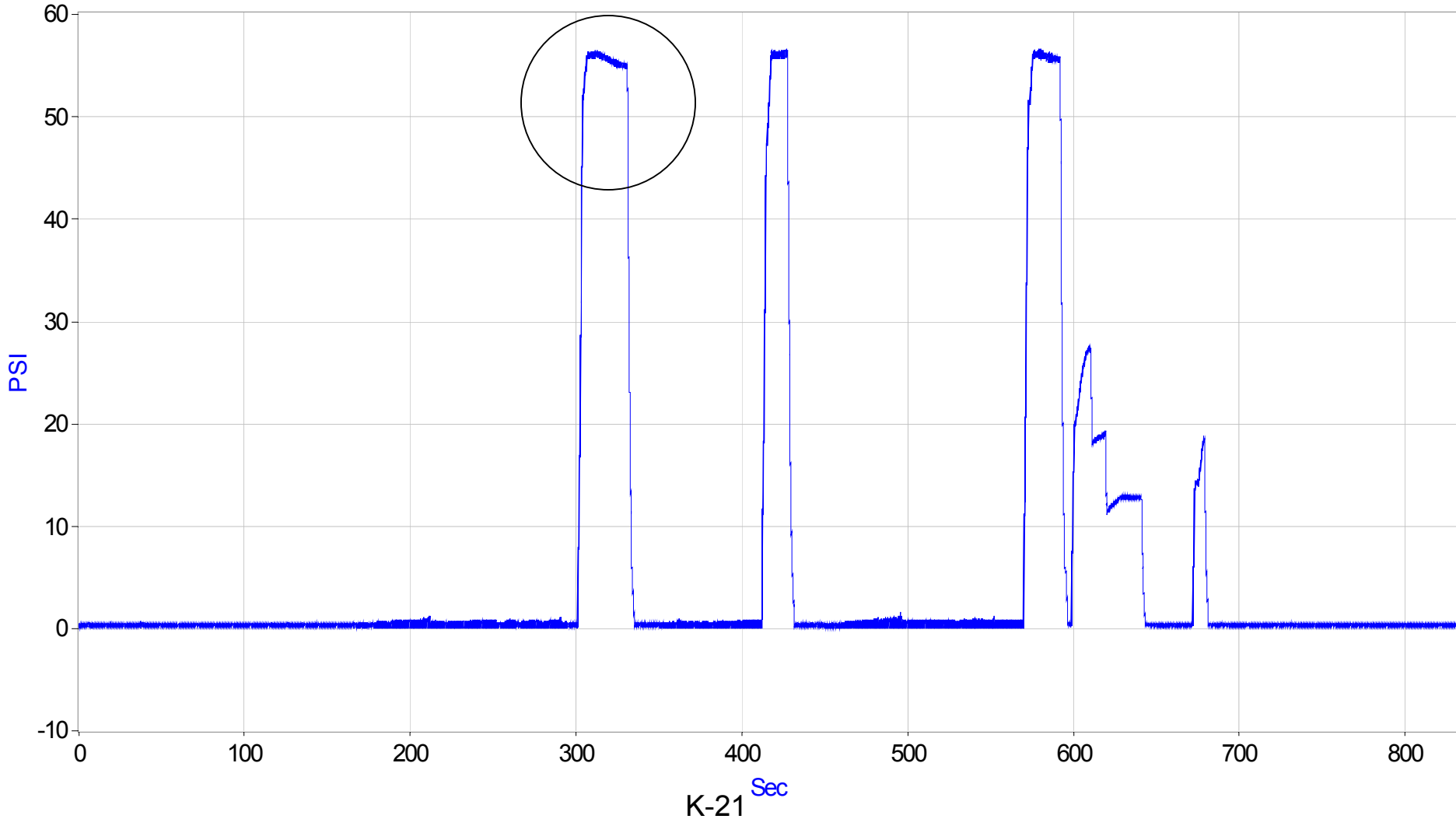

June 18–File 24–310 Seconds Braking, No Sustained Oscillations Instrumented Axle In Lead

No Sustained Oscillations

AB3.1.39_AXLE1LLINK

Sustained Oscillations

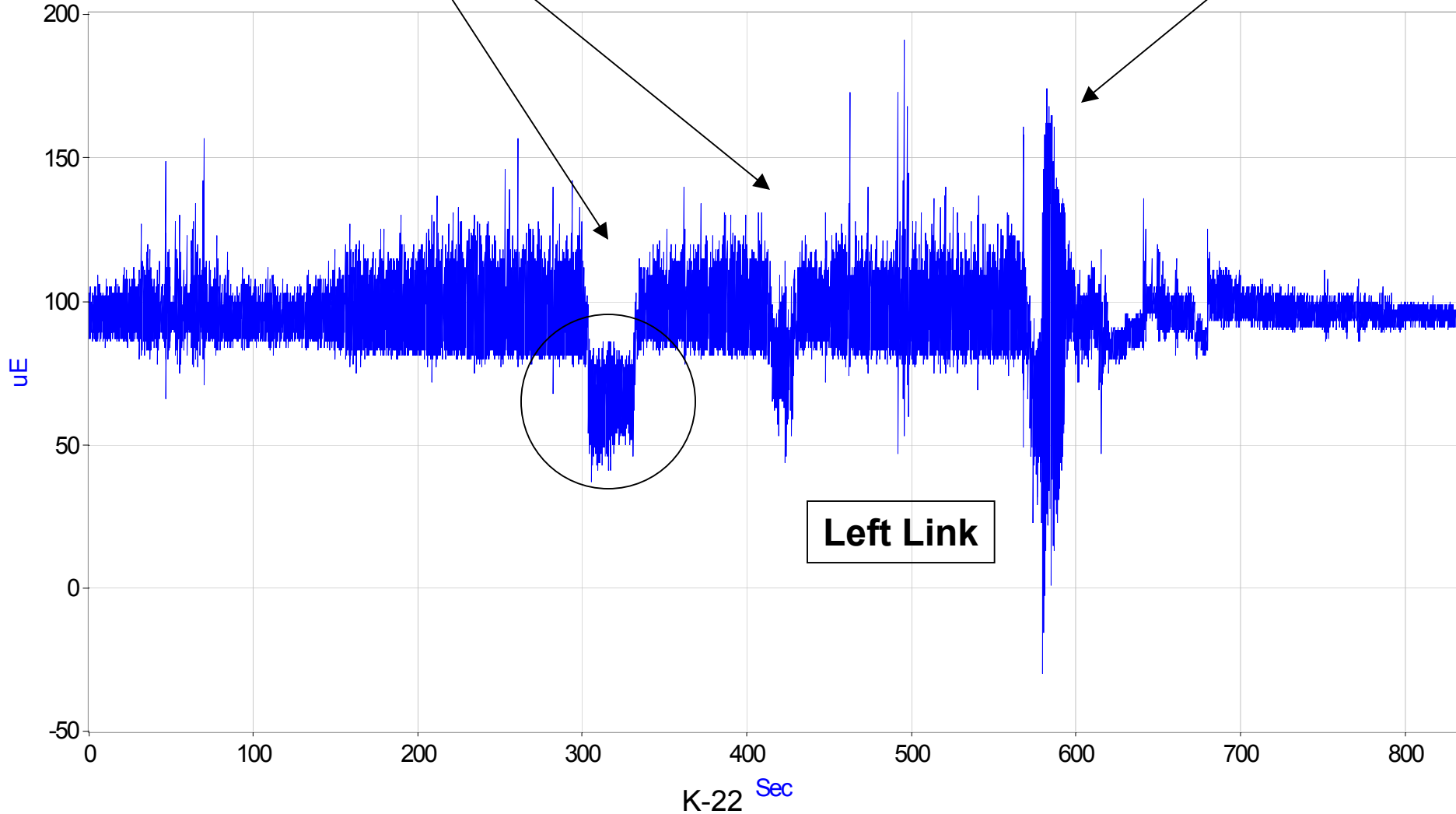

June 18–File 24–310 Seconds Braking, No Sustained Oscillations Instrumented Axle In Lead

No Sustained Oscillations

AB3.1.40_AXLE1RLINK

Sustained Oscillations

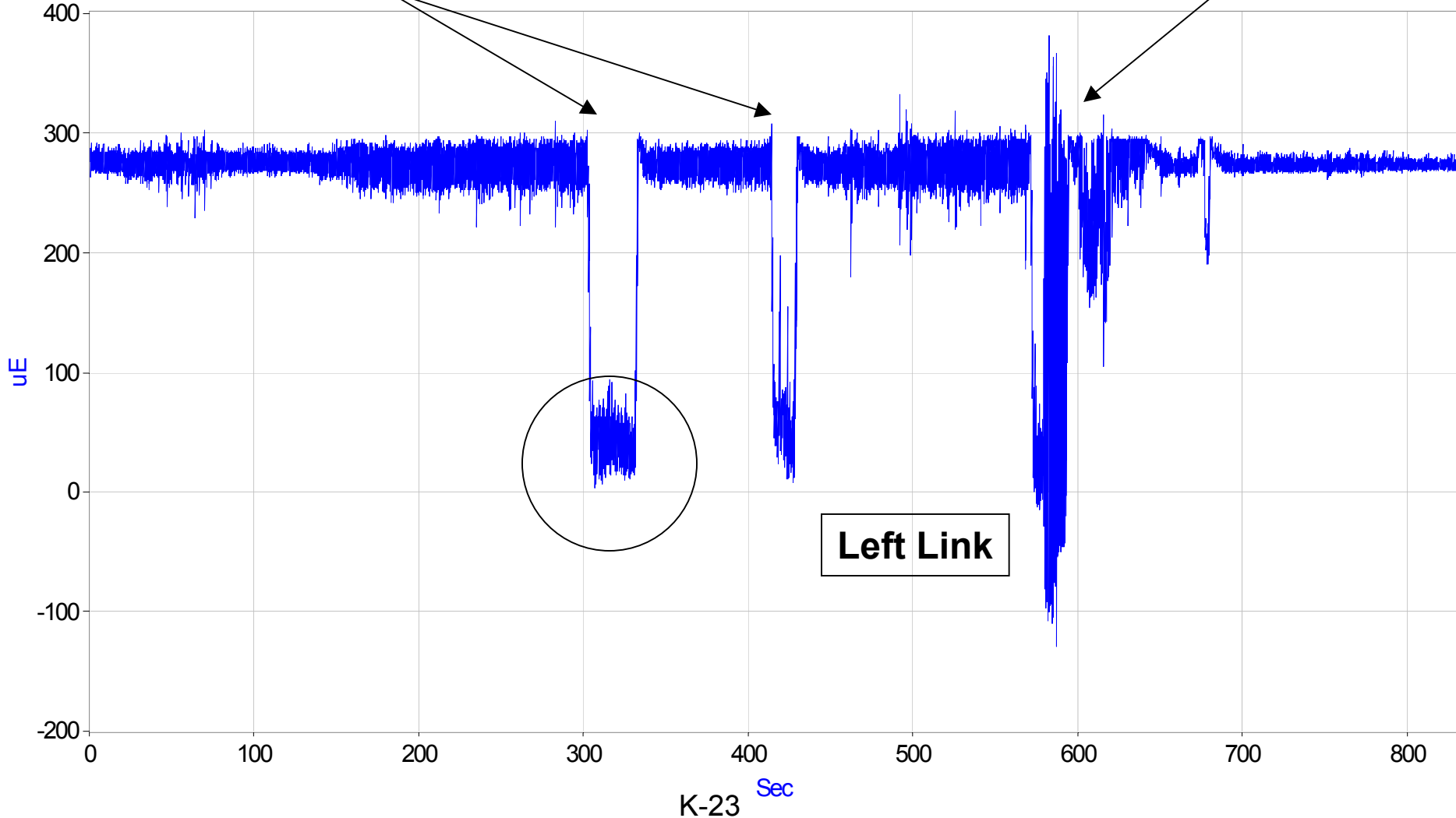

June 18–File 24–310 Seconds Braking, No Sustained Oscillations Instrumented Axle In Lead

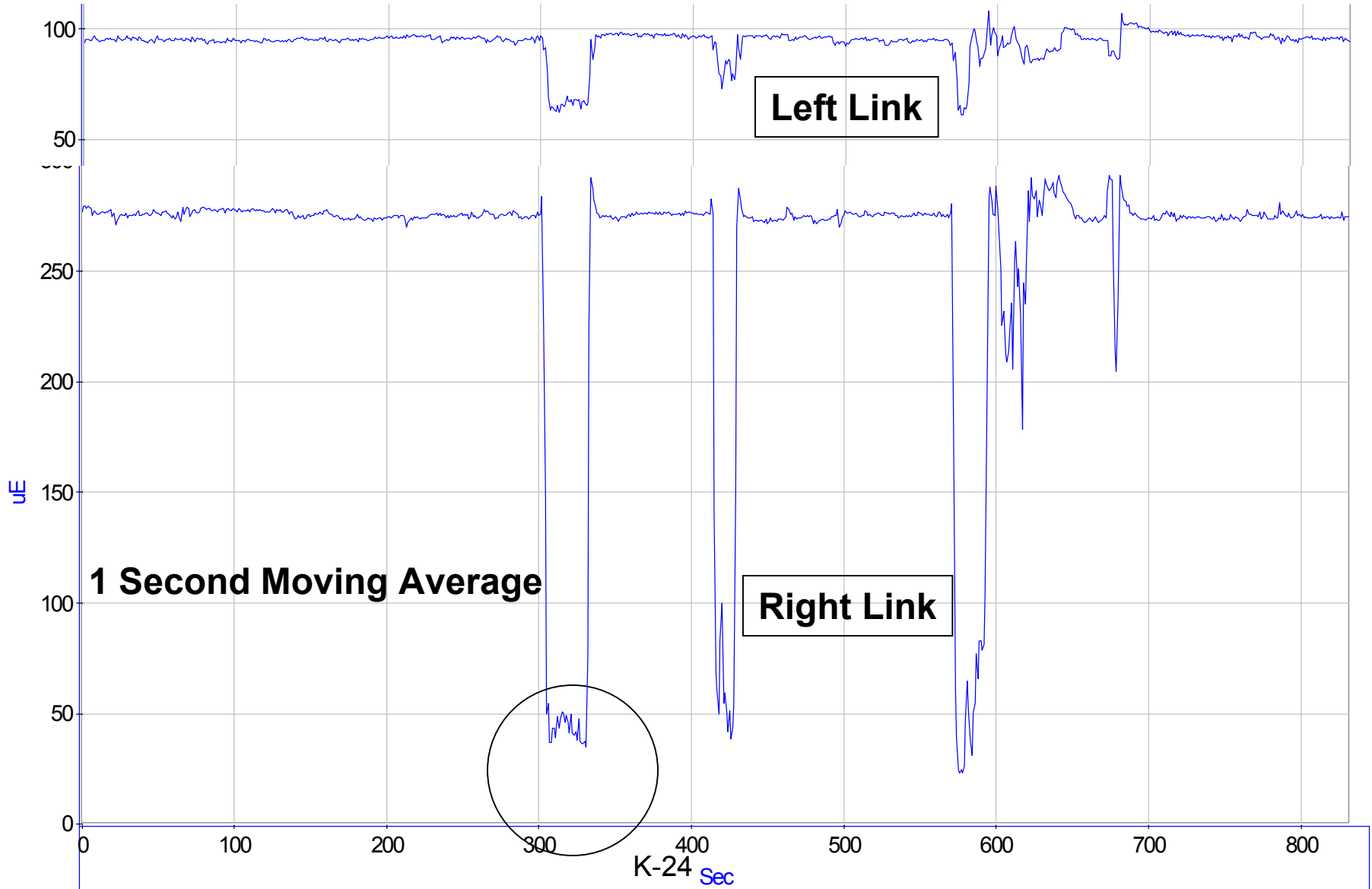

June 18–File 24–310 Seconds Braking, No Sustained Oscillations Instrumented Axle In Lead

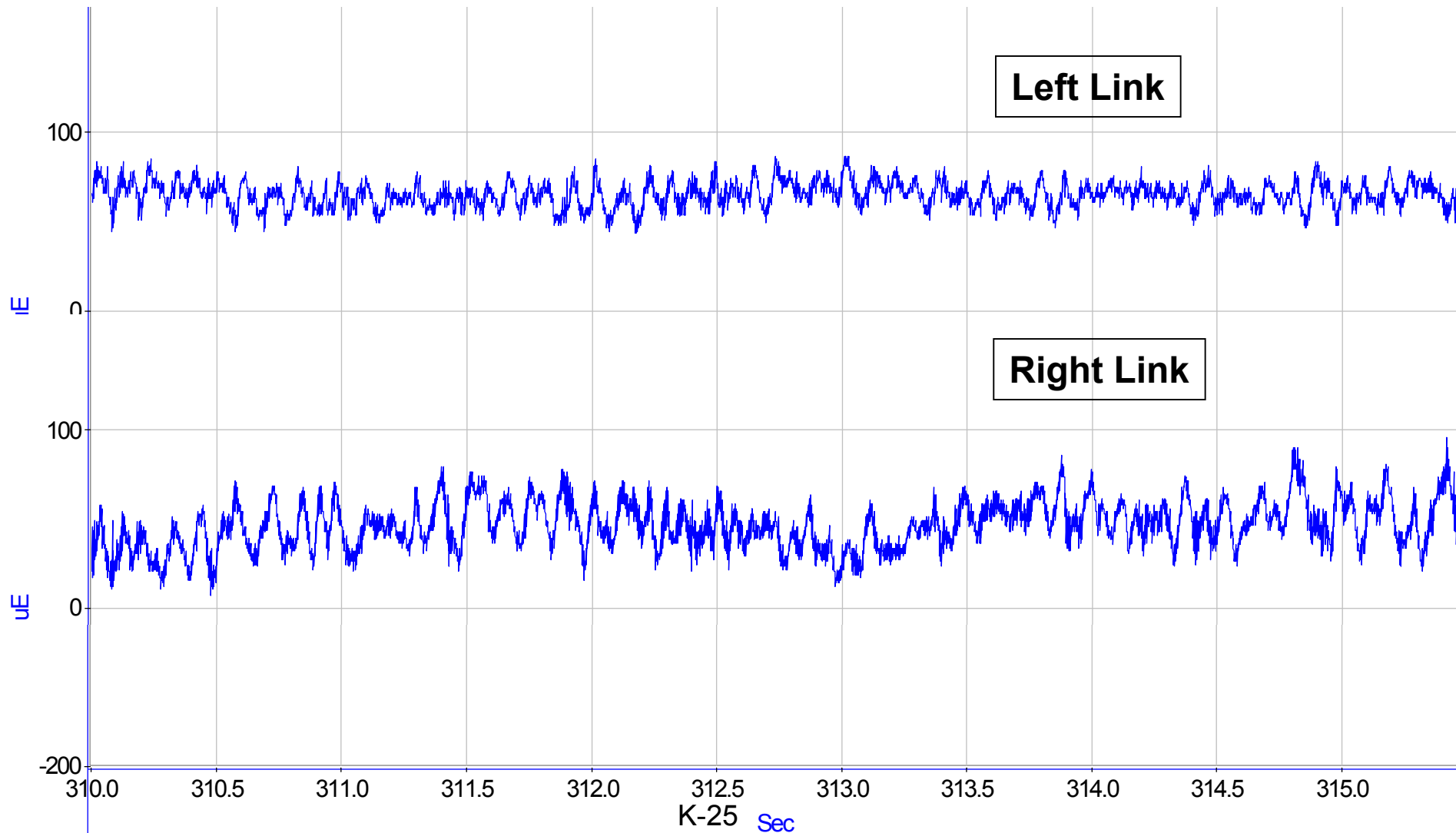

June 18–File 24–310 Seconds Braking, No Sustained Oscillations Instrumented Axle In Lead

PSD of WABTEC/SAB-WABCO Disc, Left Link Strain,
16384 points, 5 point moving avg, t = 310 s, speed = 117 mph

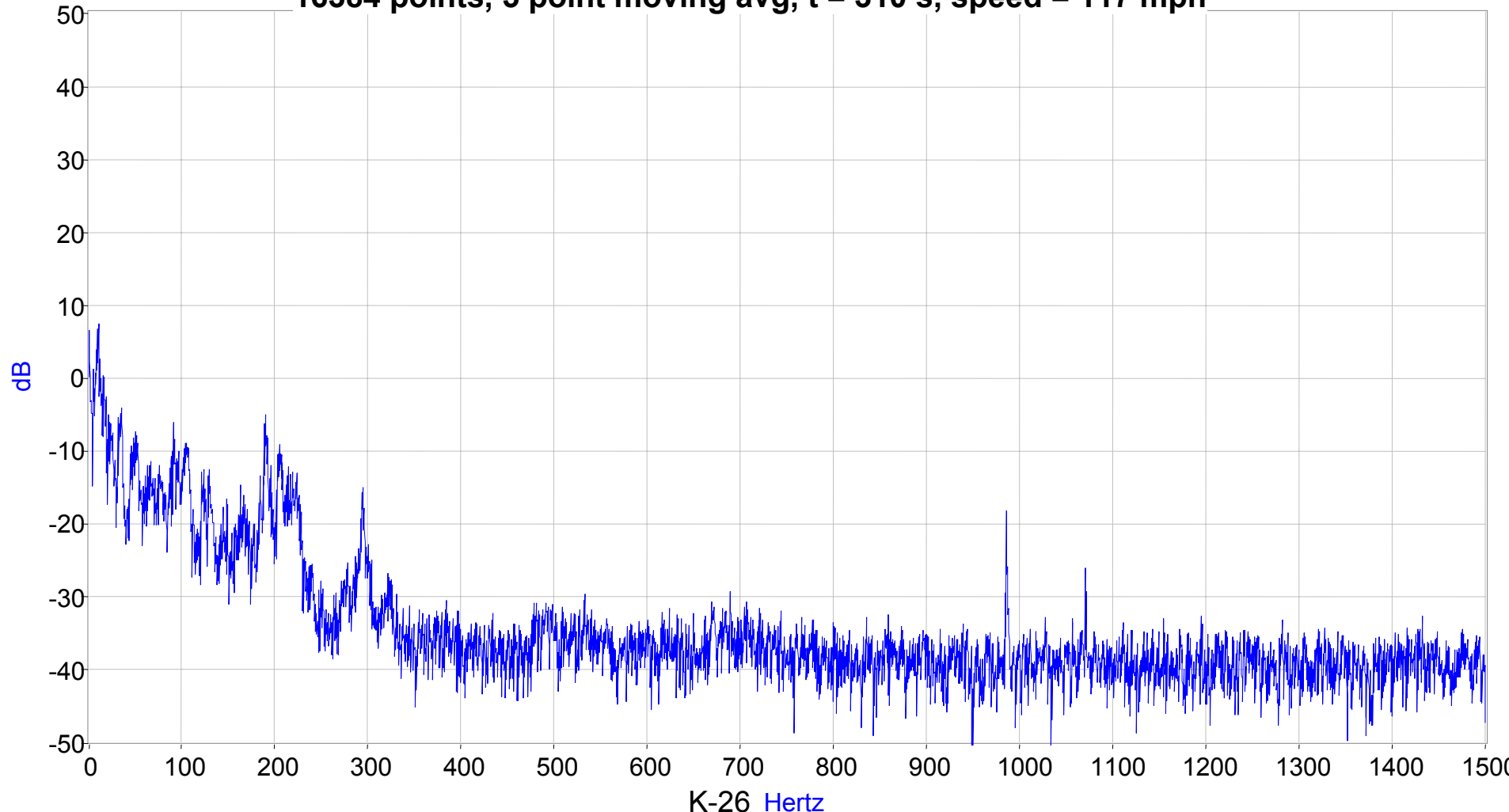

June 18–File 24–310 Seconds Braking, No Sustained Oscillations Instrumented Axle In Lead

PSD of WABTEC/SAB-WABCO Disc, Right Link Strain,
16384 points, 5 point moving avg, t = 310 s, speed = 117 mph

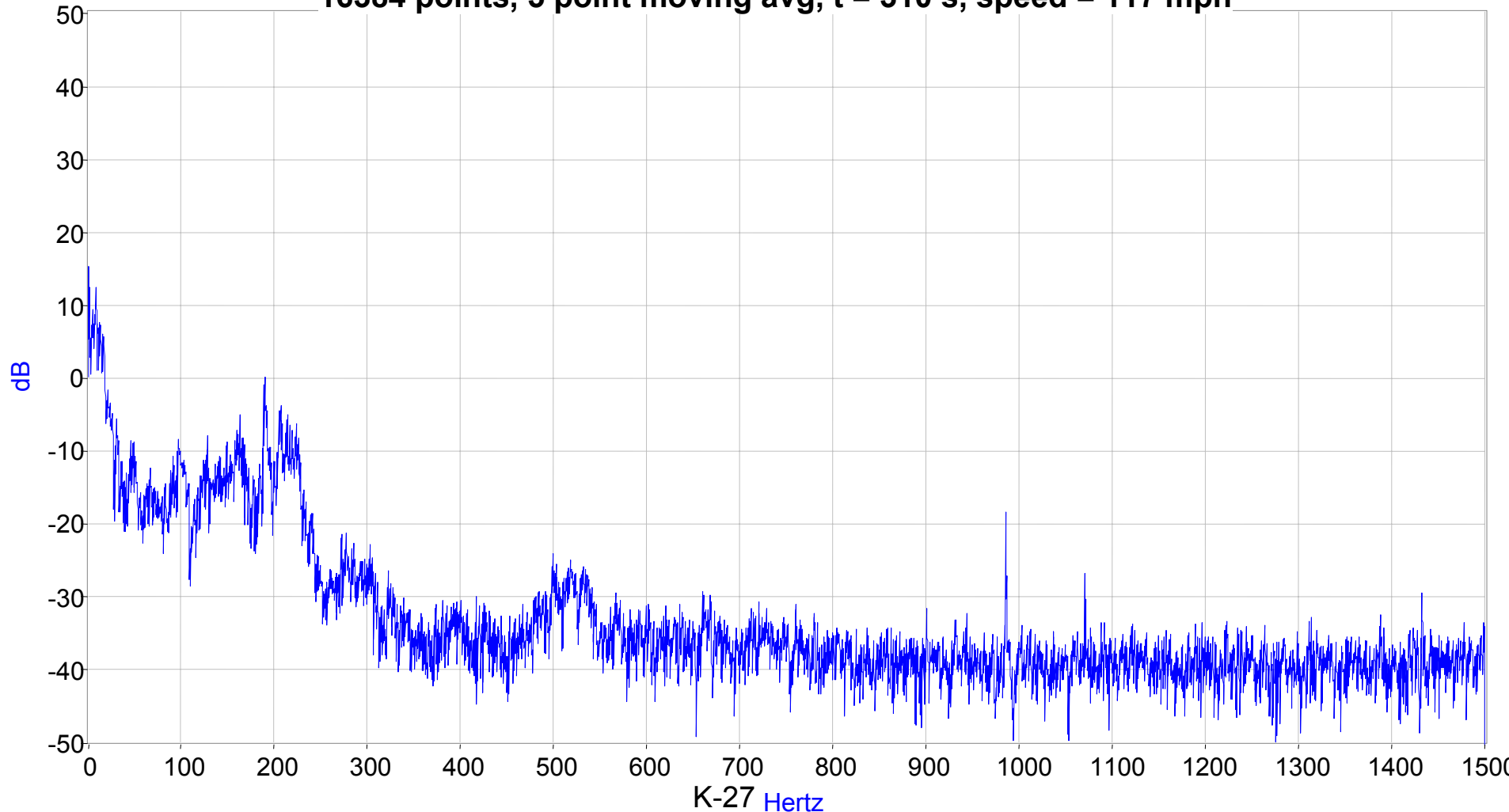

June 18–File 24–310 Seconds Braking, No Sustained Oscillations Instrumented Axle In Lead

Date/File/Time	Sustained Oscillation	Axle	Harmonic Content	Strain Change
June 18 – File 24 - 310	No	Lead	No	Compression

Date/File/Time	Sustained Oscillation	Axle	Left Link Microstrain	Right Link Microstrain
June 18 – File 24 - 310	No	Lead	-32	-231

June 18–File 24
Braking
Sustained Oscillations
Instrumented Axle in Lead
 $t = 580$ seconds
Speed = 110 mph

June 18—File 24—580 Seconds

Braking

Sustained Oscillations Instrumented Axle In Lead

AB3.1.13_CYLPRESS1

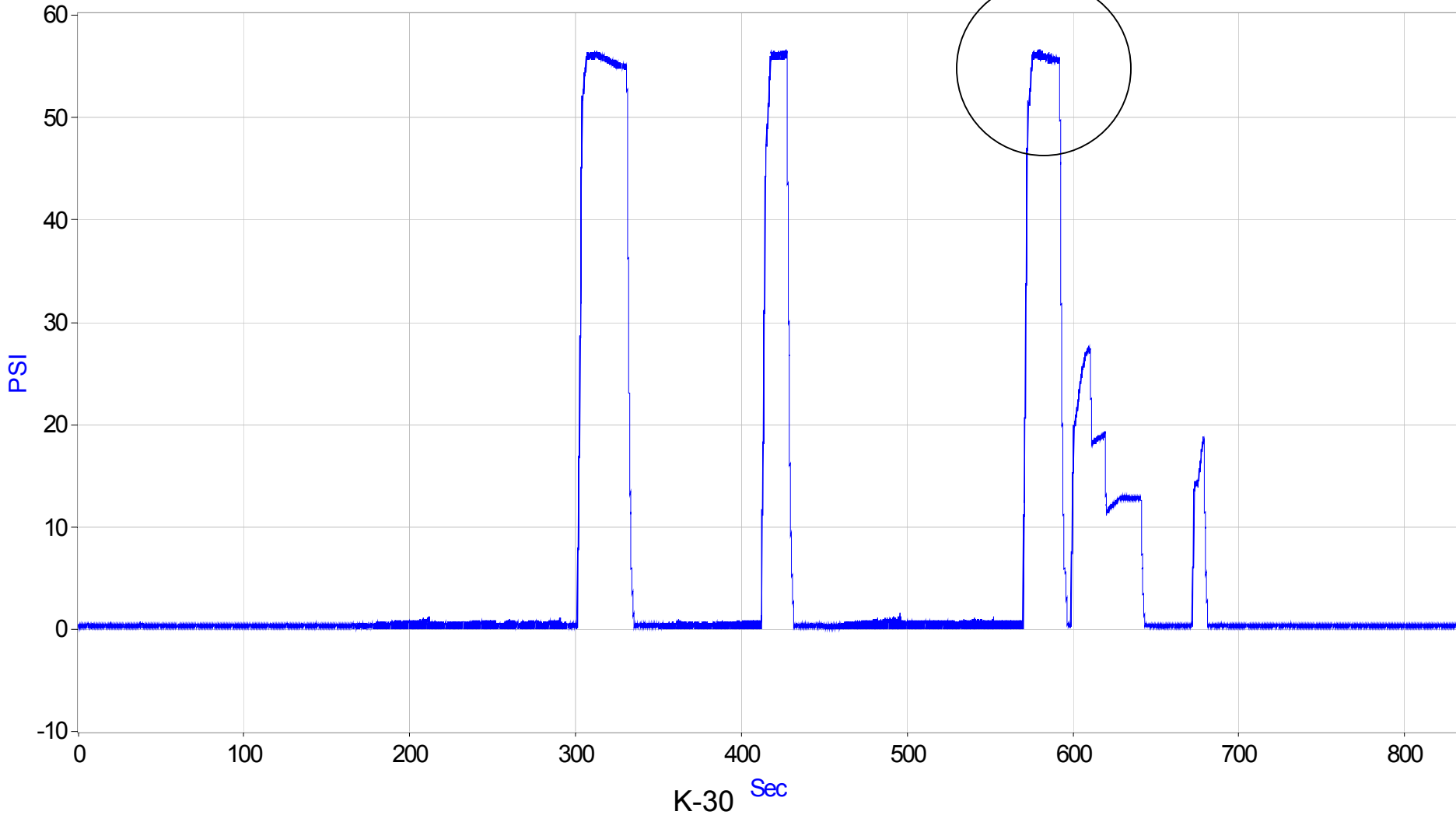

June 18—File 24—580 Seconds

Braking

Sustained Oscillations Instrumented Axle In Lead

AB3.1.39_AXLE1LLINK

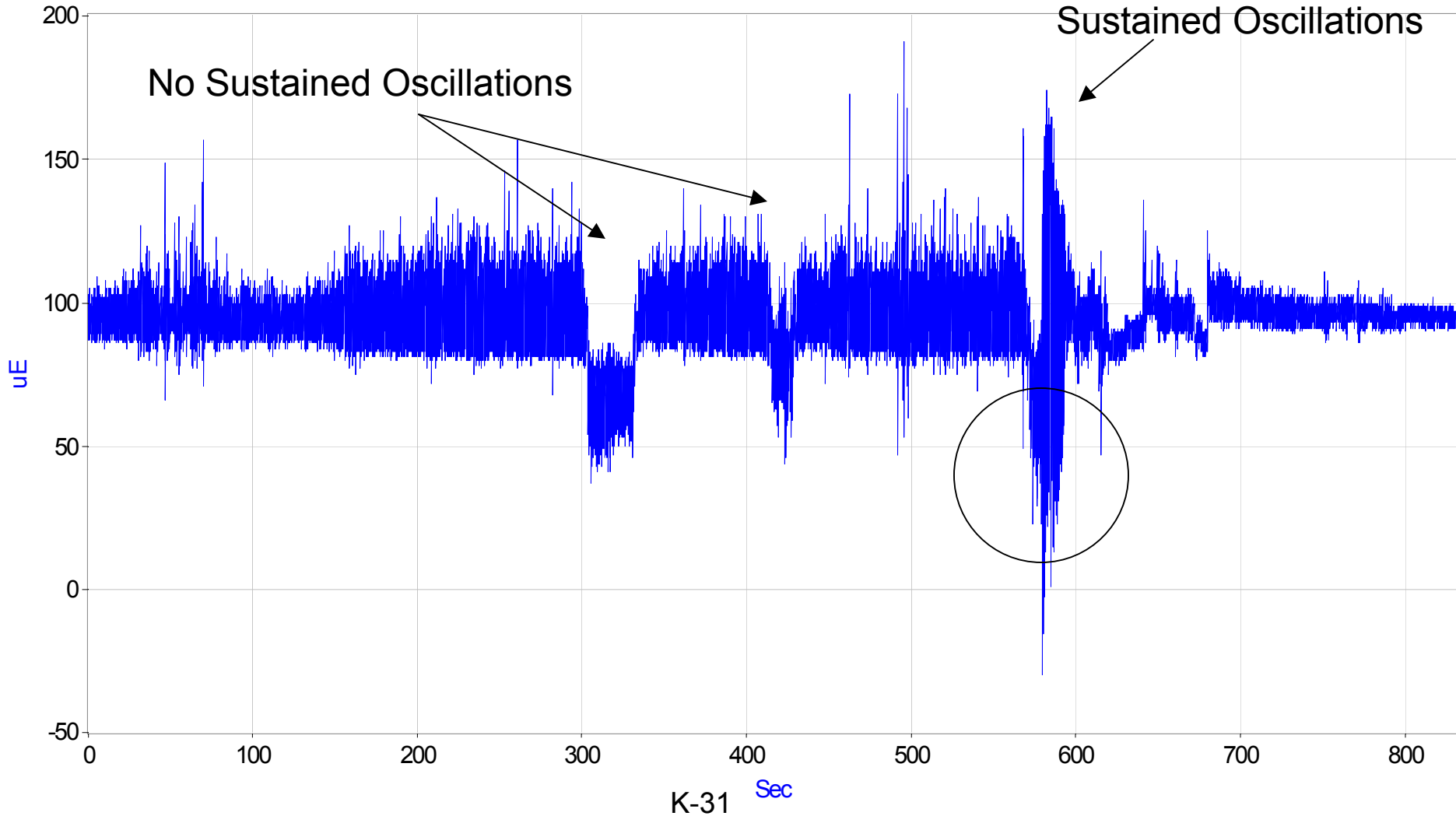

June 18–File 24–580 Seconds Braking

Sustained Oscillations Instrumented Axle In Lead

No Sustained Oscillations

AB3.1.40_AXLE1RLINK

Sustained Oscillations

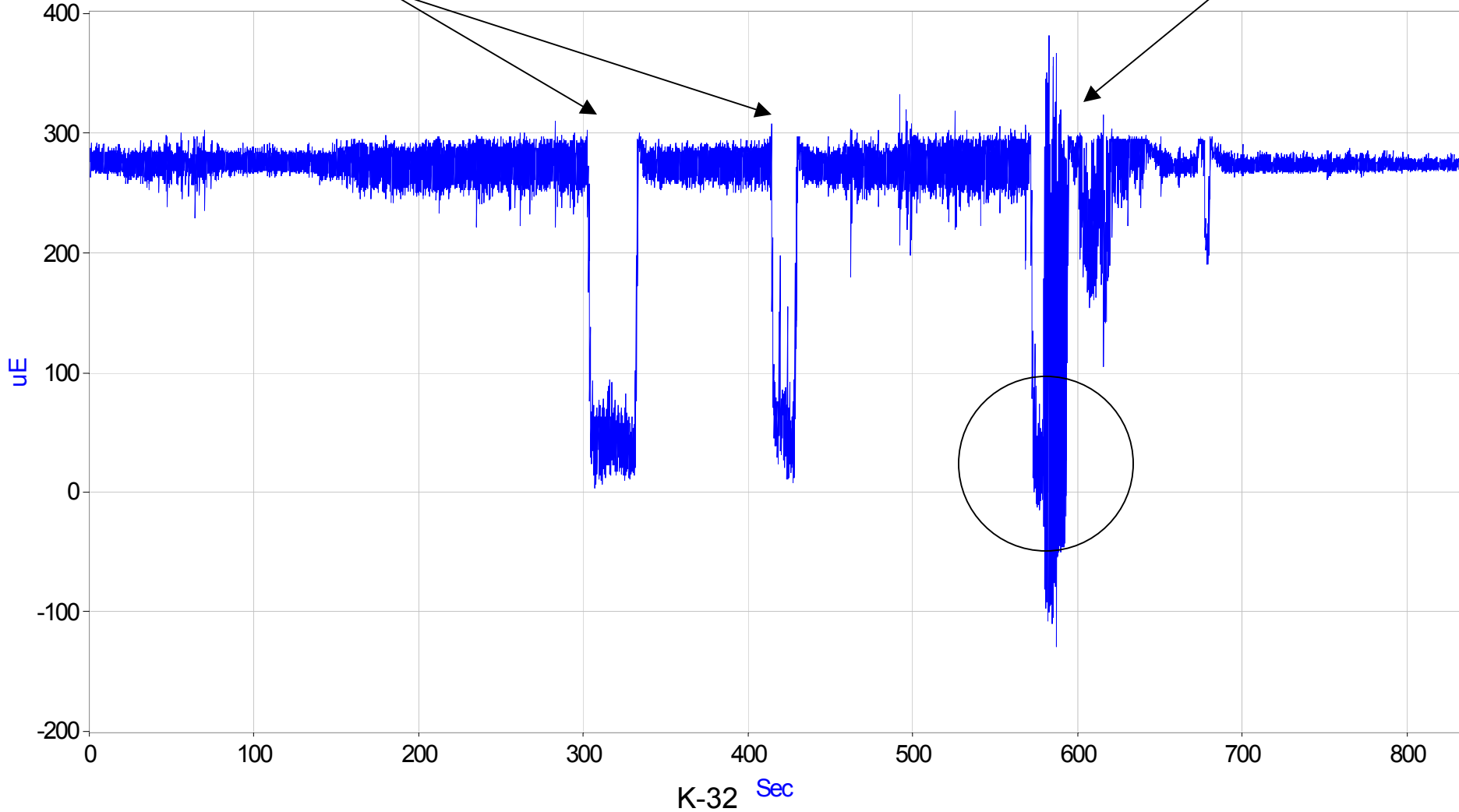

June 18—File 24—580 Seconds Braking

Sustained Oscillations Instrumented Axle In Lead

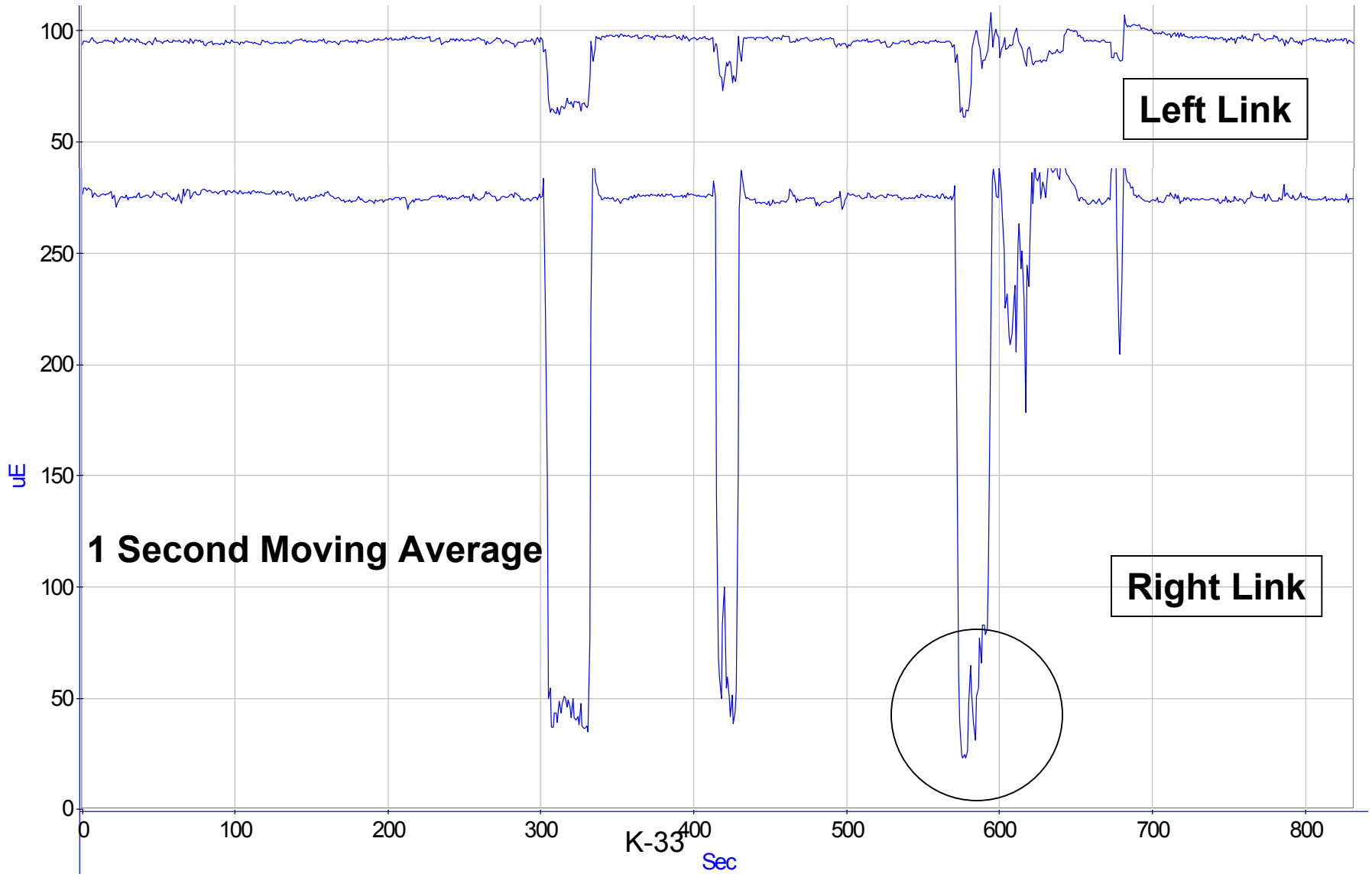

June 18—File 24—580 Seconds Braking

Sustained Oscillations Instrumented Axle In Lead

WABTEC/SAB-WABCO Disc, Left Link Strain

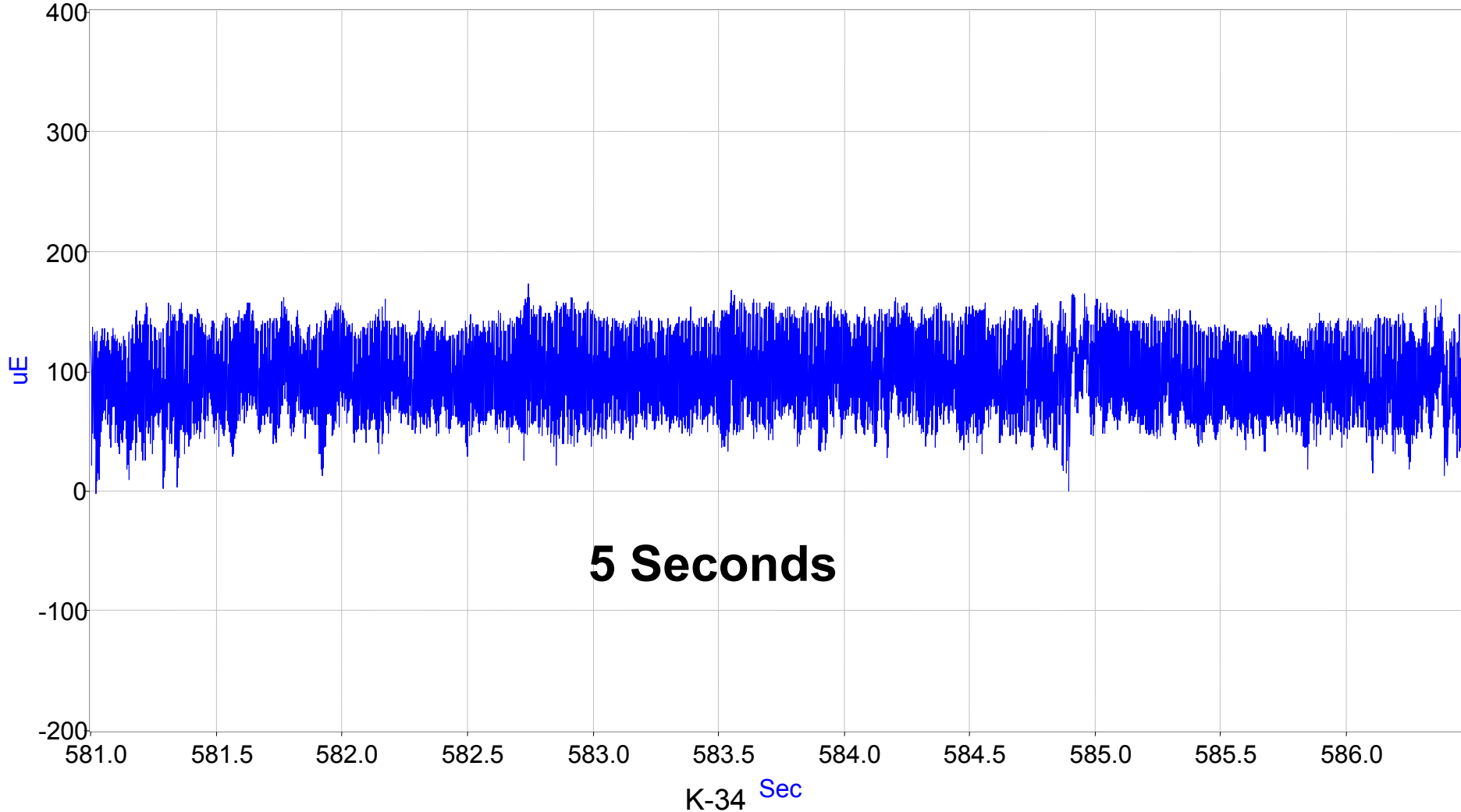

June 18—File 24—580 Seconds

Braking

Sustained Oscillations Instrumented Axle In Lead

WABTEC/SAB-WABCO Disc, Right Link Strain

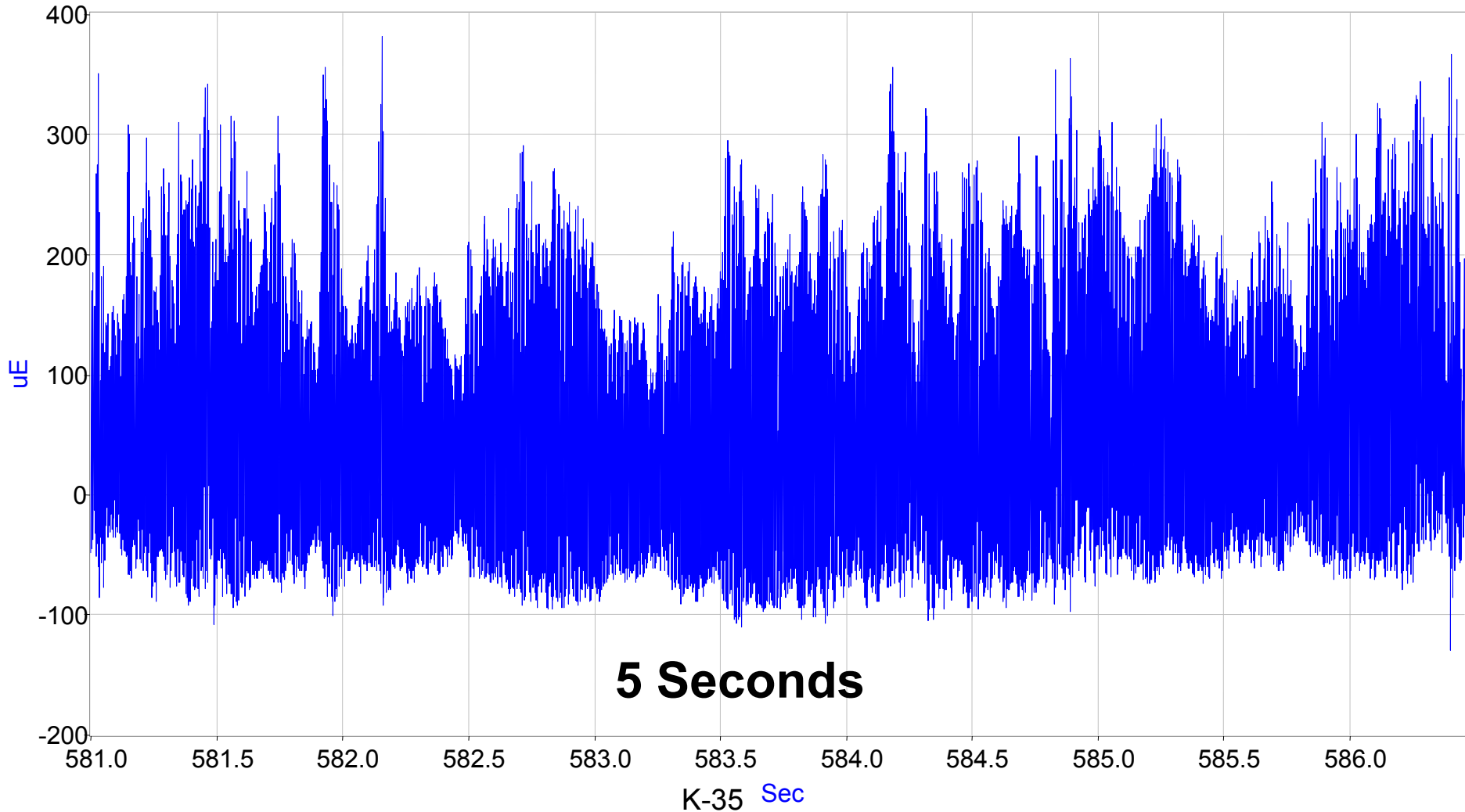

June 18—File 24—580 Seconds

Braking

Sustained Oscillations Instrumented Axle In Lead

WABTEC/SAB-WABCO Disc, Left Link Strain

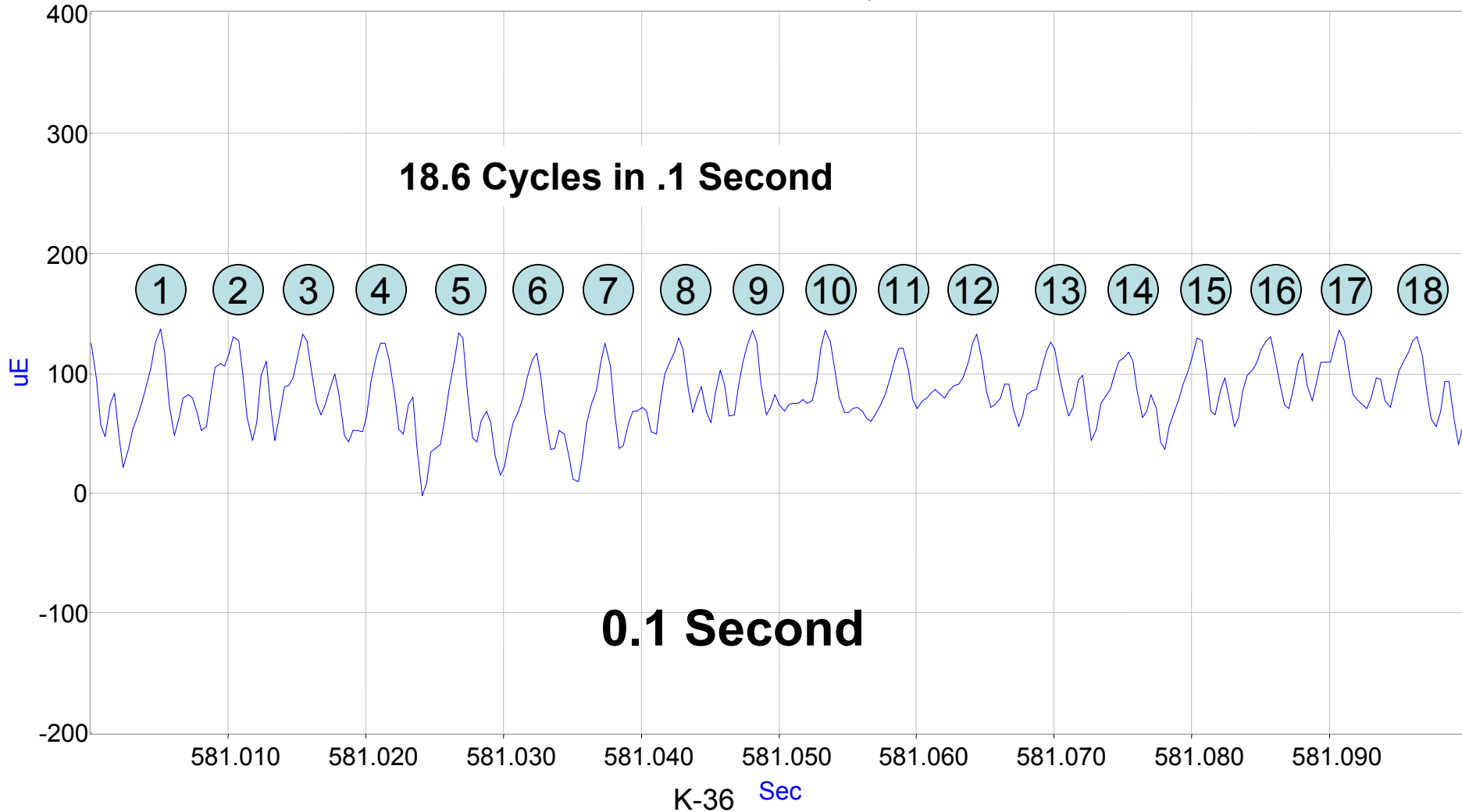

June 18–File 24 (Brake, BOP)

WABTEC/SAB-WABCO Disc, Right Link Strain

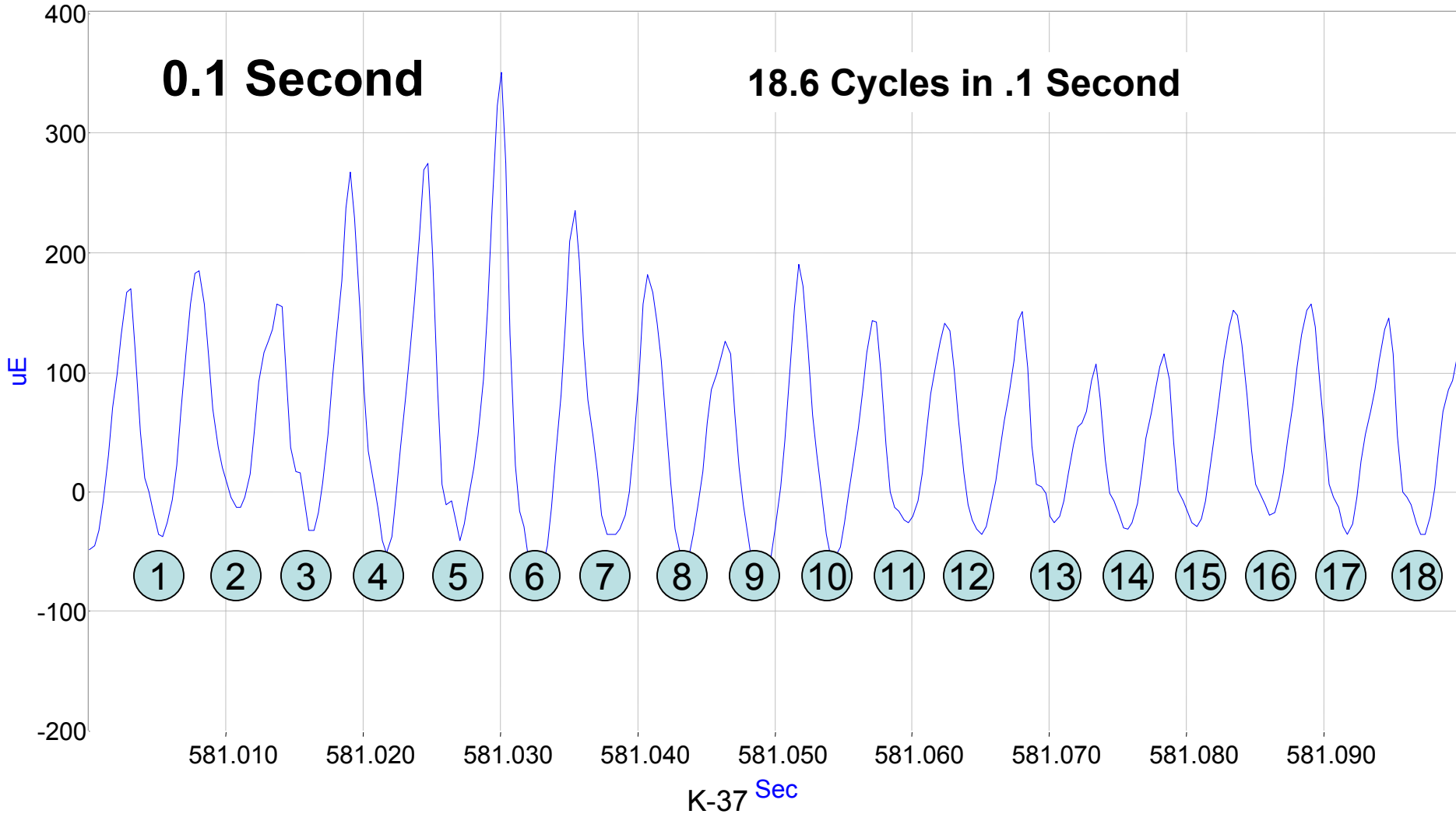

Links Out Of Phase

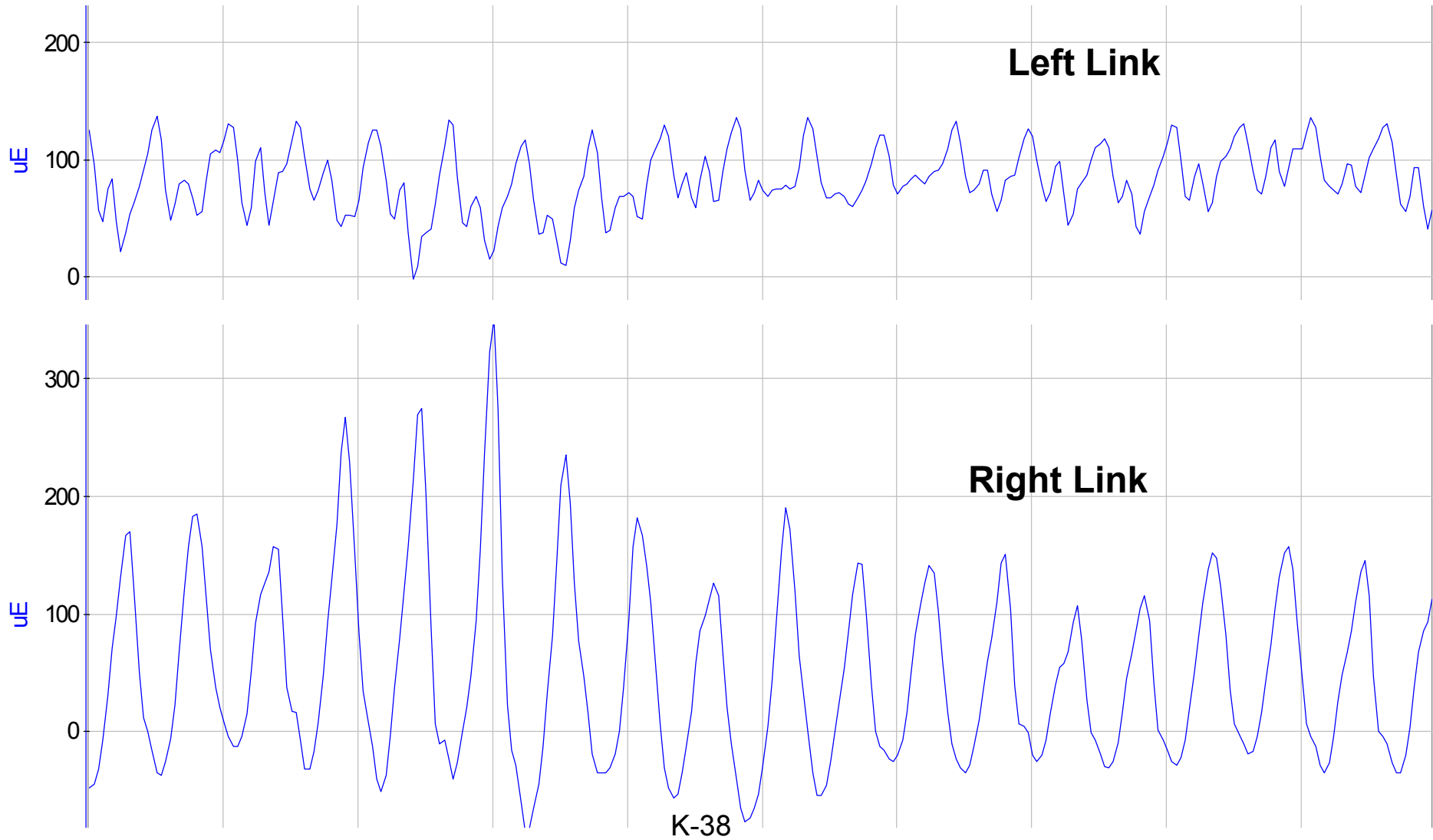

June 18—File 24—580 Seconds

Braking

Sustained Oscillations Instrumented Axle In Lead

PSD of WABTEC/SAB-WABCO Disc, Right Link Strain,
16384 points, 5 point moving avg, t = 581 s, speed = 110 mph

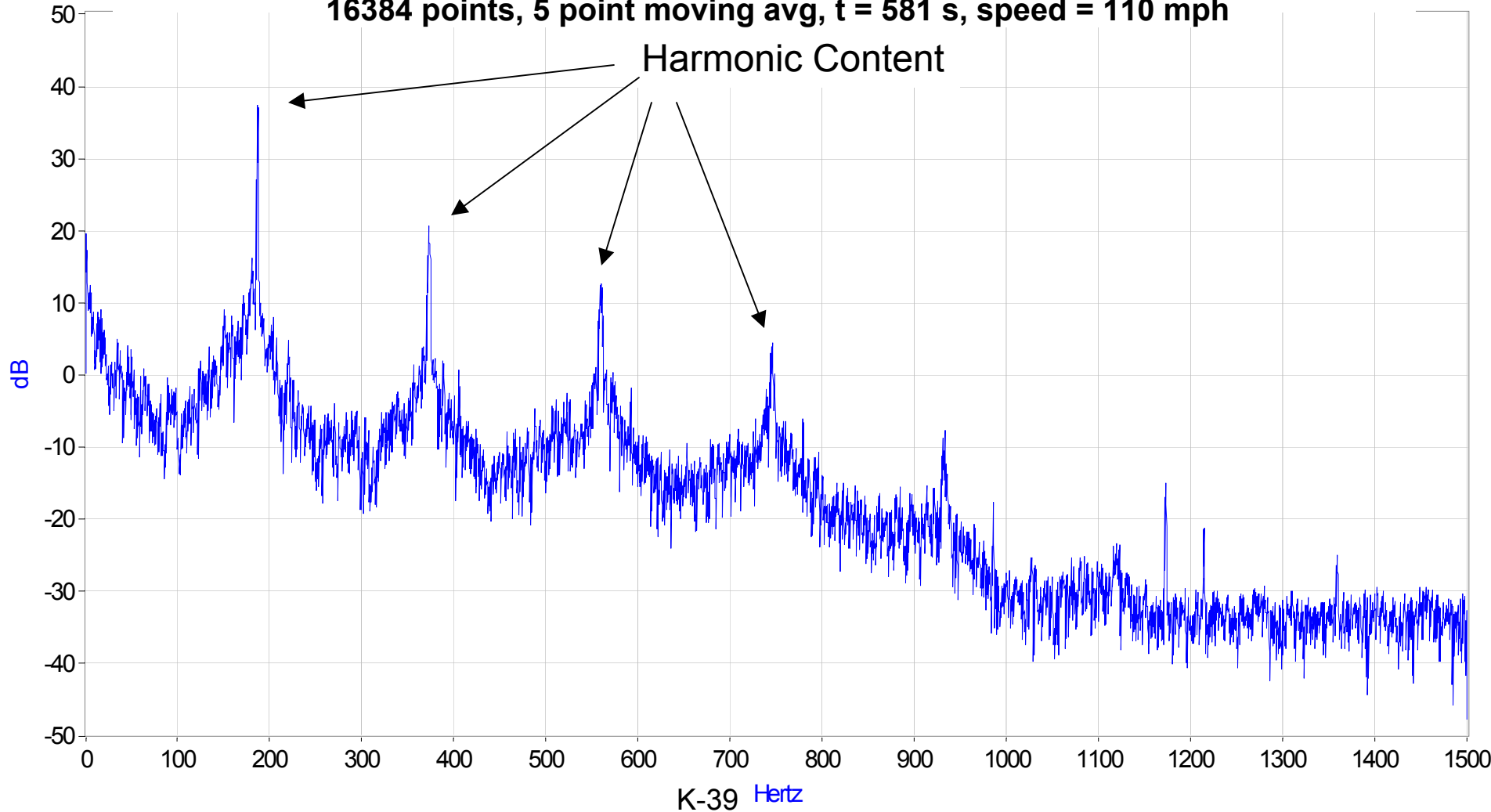

June 18—File 24—580 Seconds

Braking

Sustained Oscillations Instrumented Axle In Lead

PSD of WABTEC/SAB-WABCO Disc, Left Link Strain,
16384 points, 5 point moving avg, t = 581 s, speed = 110 mph

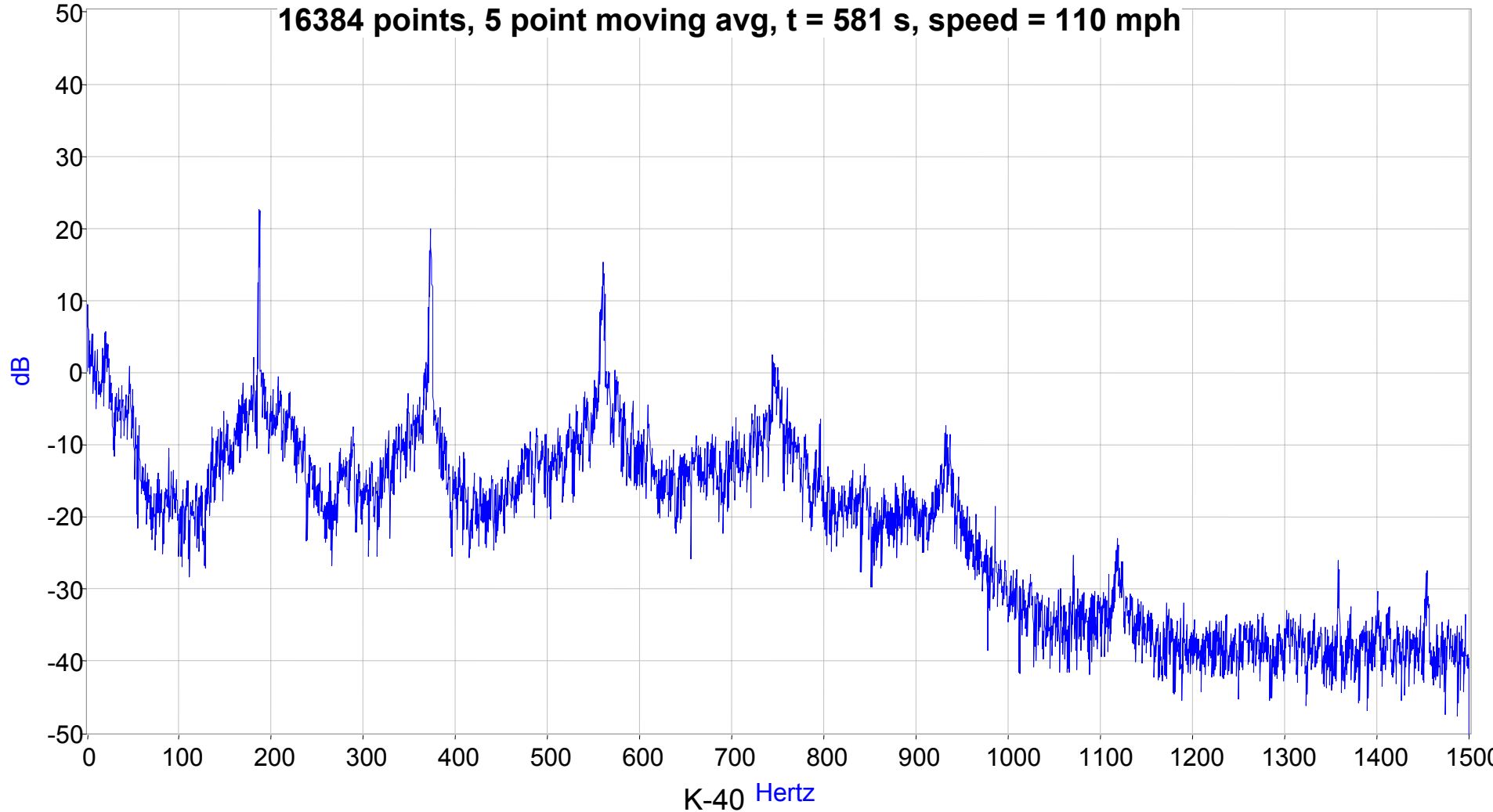

June 18–File 24–580 Seconds Braking

Sustained Oscillations Instrumented Axle In Lead

Date/File/Time	Sustained Oscillation	Axle	Harmonic Content	Strain Change
June 18 – File 24 - 580	Yes	Lead	Yes	Compression

Date/File/Time	Sustained Oscillation	Axle	Left Link Microstrain	Right Link Microstrain
June 18 – File 24 - 580	Yes	Lead	-32	-221

June 17–File 25
Braking
Sustained Oscillation
Instrumented Axle In Lead
 $t = 559$ seconds
Speed = 68 mph

June 17—File 25—559 Seconds Braking

Sustained Oscillation Instrumented Axle In Lead

AB3.1.13_CYLPRESS1

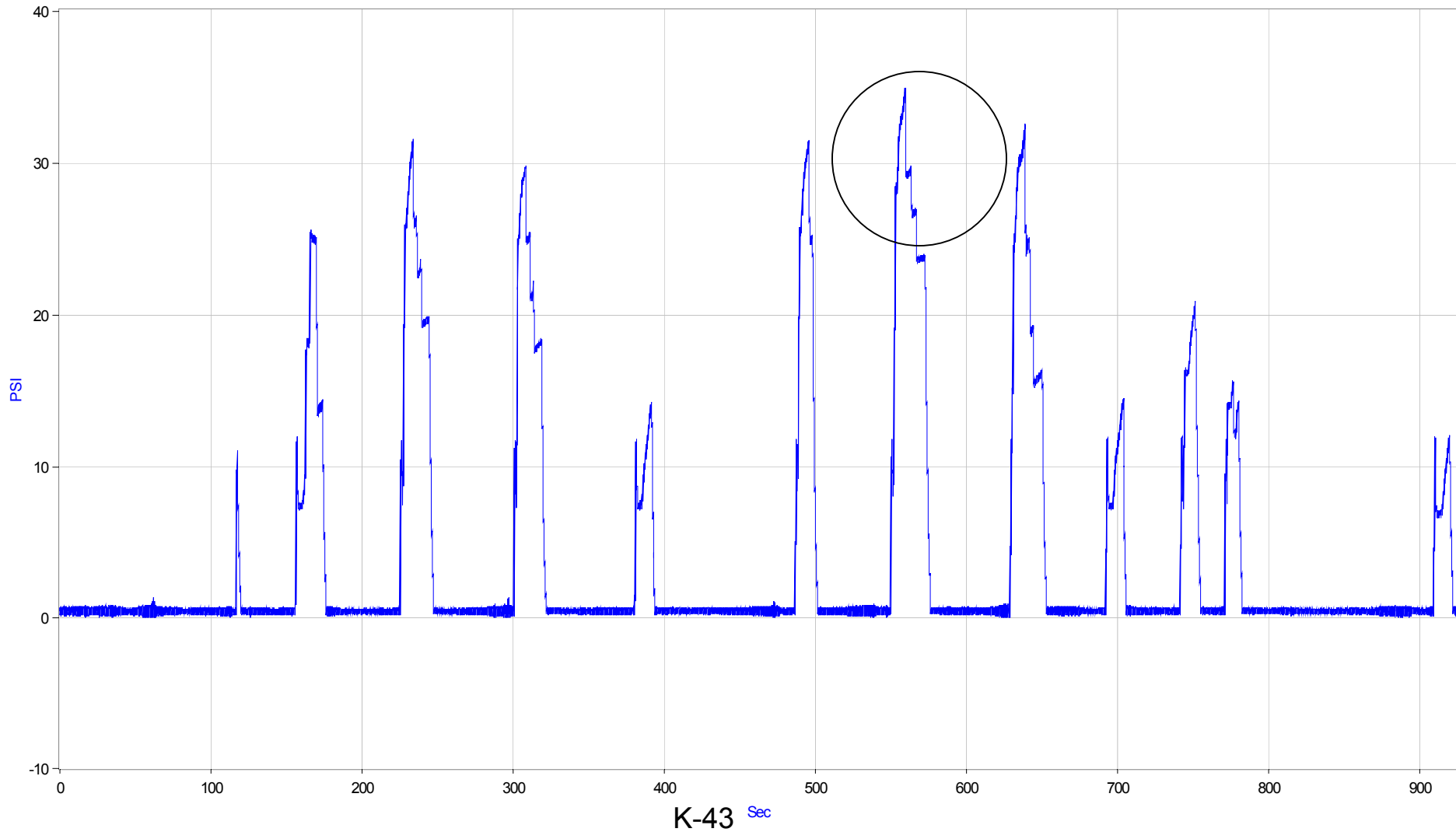

June 17—File 25—559 Seconds Braking

Sustained Oscillation Instrumented Axle In Lead

AB3.1.39_AXLE1LINK

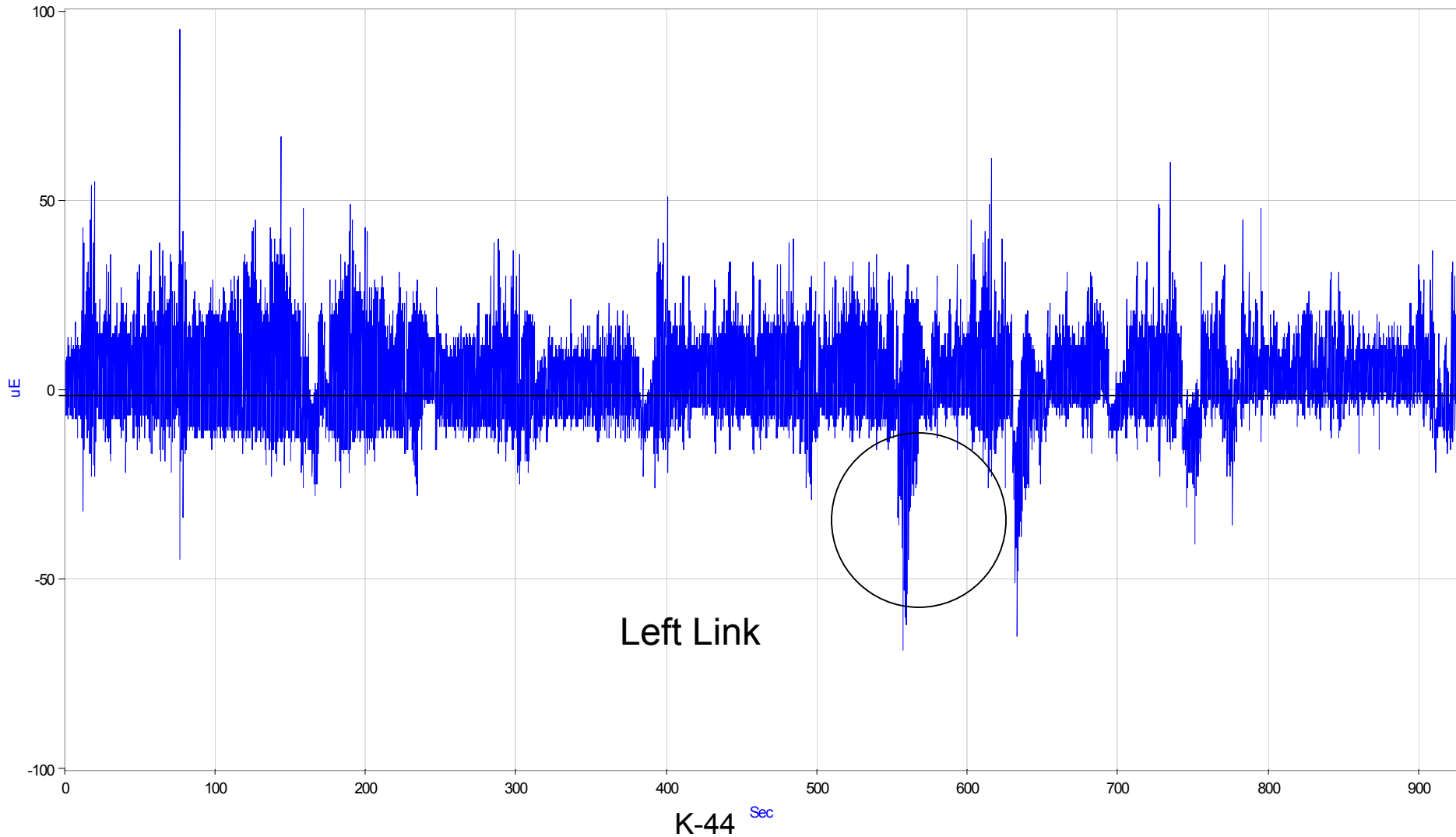

June 17–File 25–559 Seconds Braking

Sustained Oscillation Instrumented Axle In Lead

AB3.1.40_AXLE1RLINK

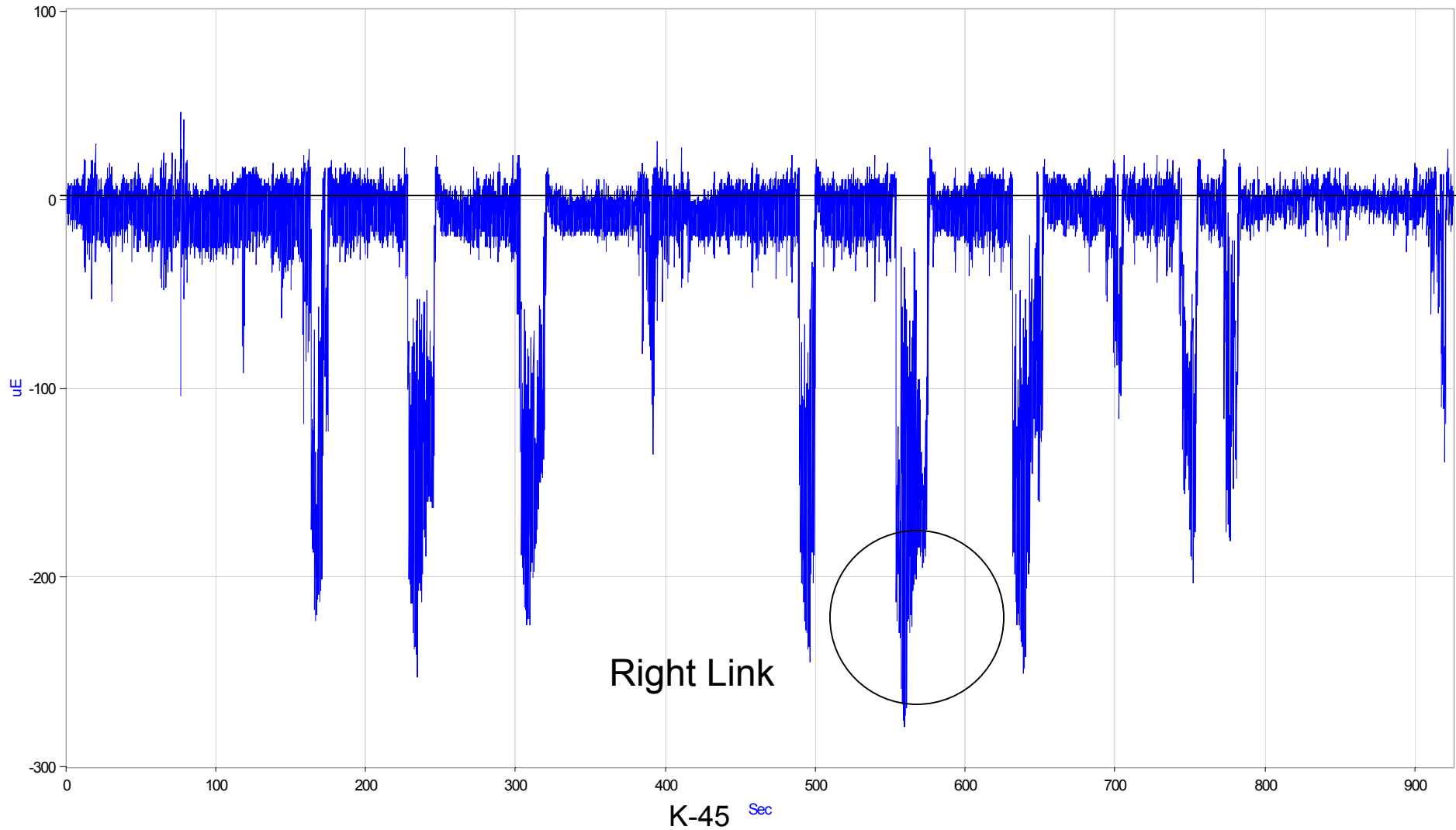

June 17–File 25–559 Seconds Braking

Sustained Oscillation Instrumented Axle In Lead

WABTEC/SAB-WABCO Disc, Left Link Strain, 3000 point moving avg

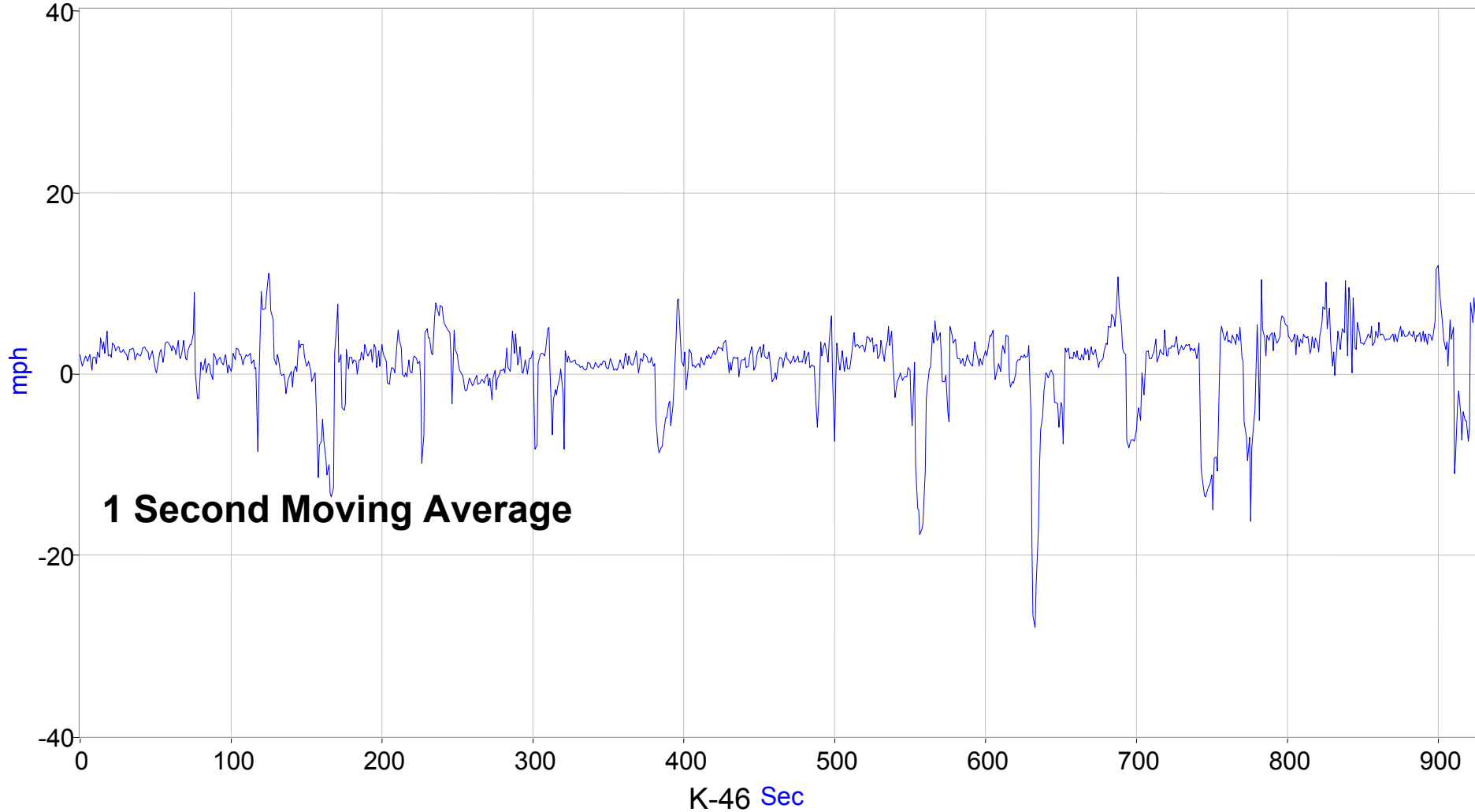

June 17—File 25—559 Seconds

Braking

Sustained Oscillation Instrumented Axle In Lead

Knorr Disc, Left Link Strain, 3000 point moving avg

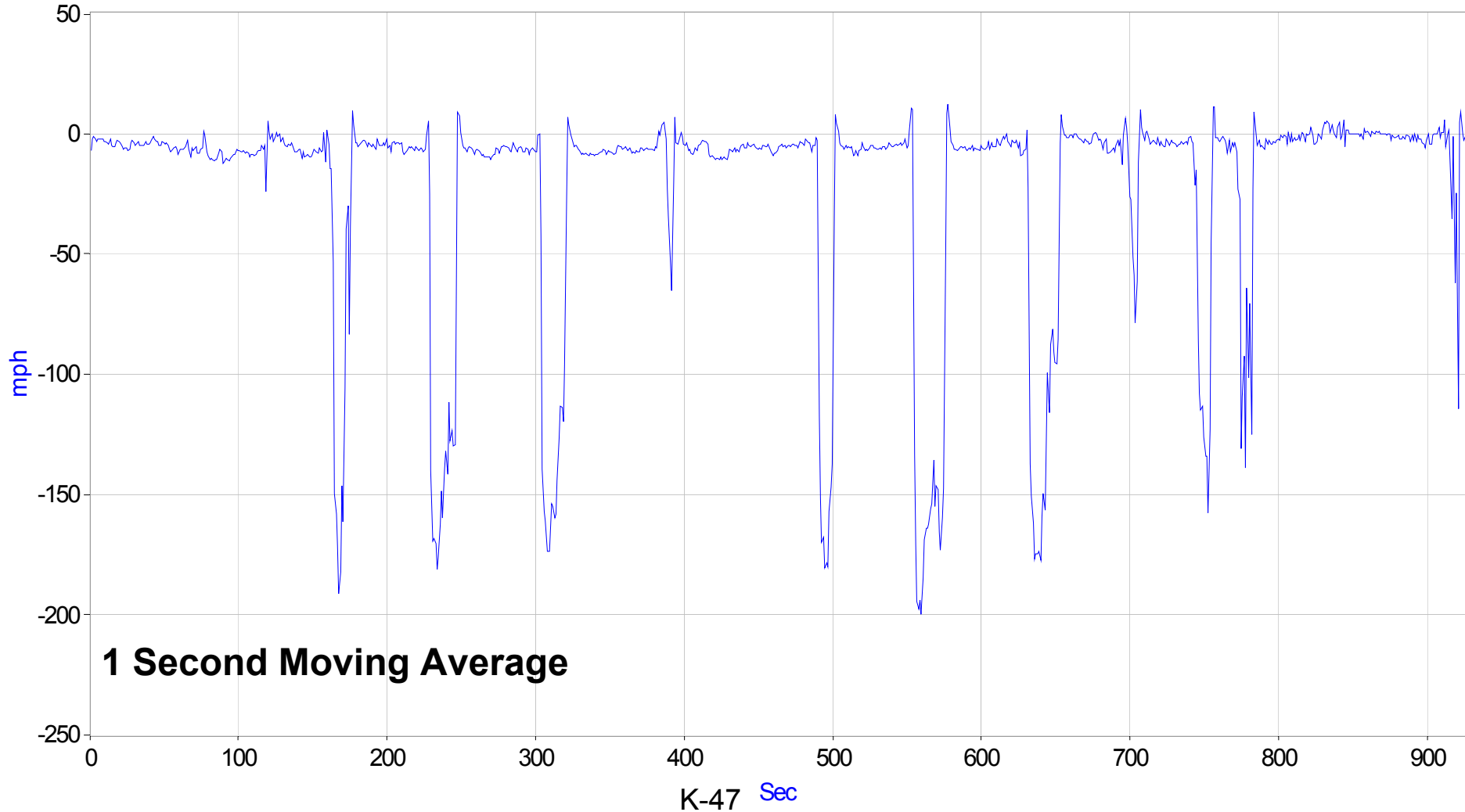

June 17–File 25–559 Seconds

Braking

Sustained Oscillation Instrumented Axle In Lead

WABTEC/SAB-WABCO Disc, Right Link Strain

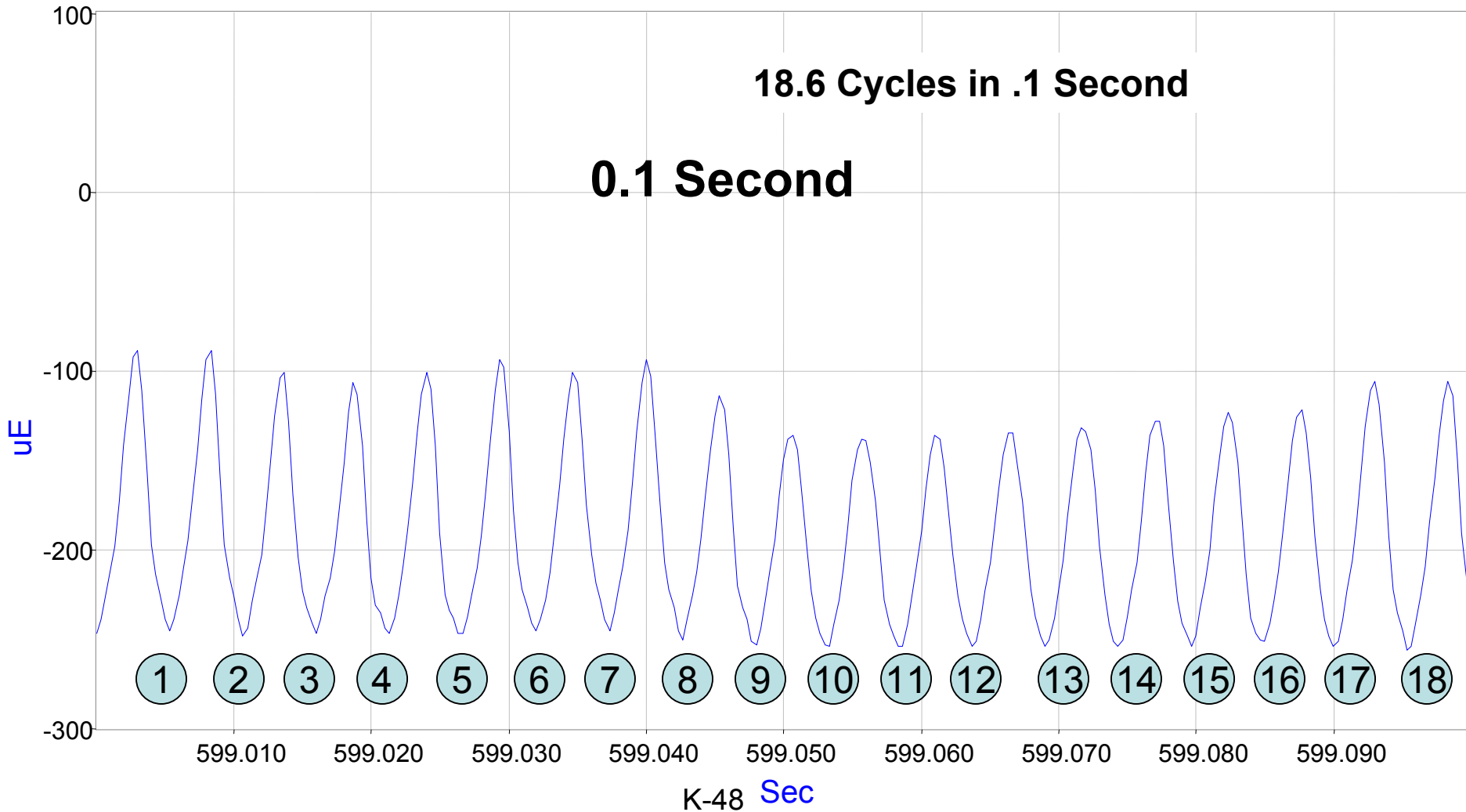

June 17—File 25—559 Seconds Braking

Sustained Oscillation Instrumented Axle In Lead

WABTEC/SAB-WABCO Disc, Left Link Strain

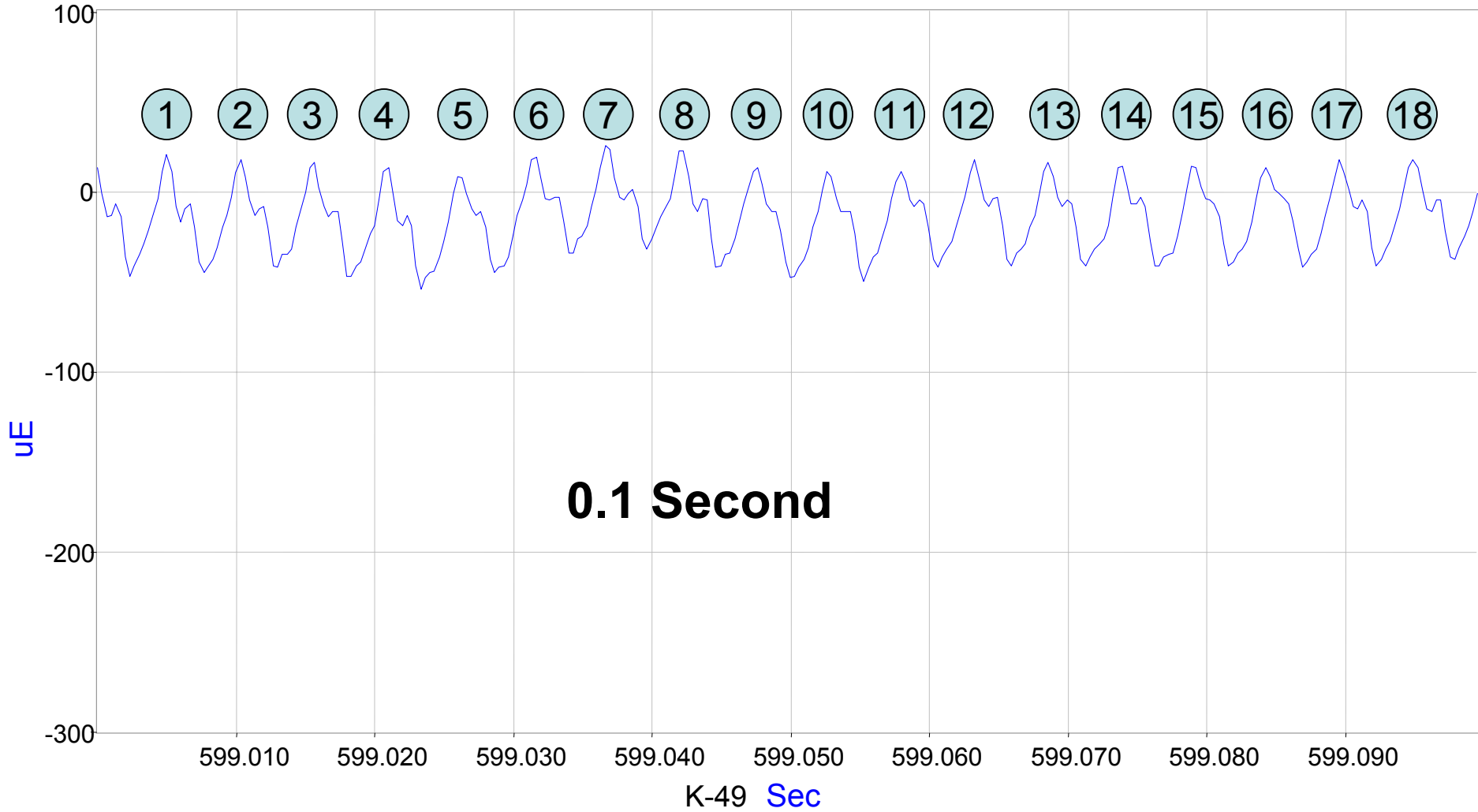

June 17–File 25–559 Seconds
Braking

Sustained Oscillation Instrumented Axle In Lead
Right And Left Link Out Of Phase

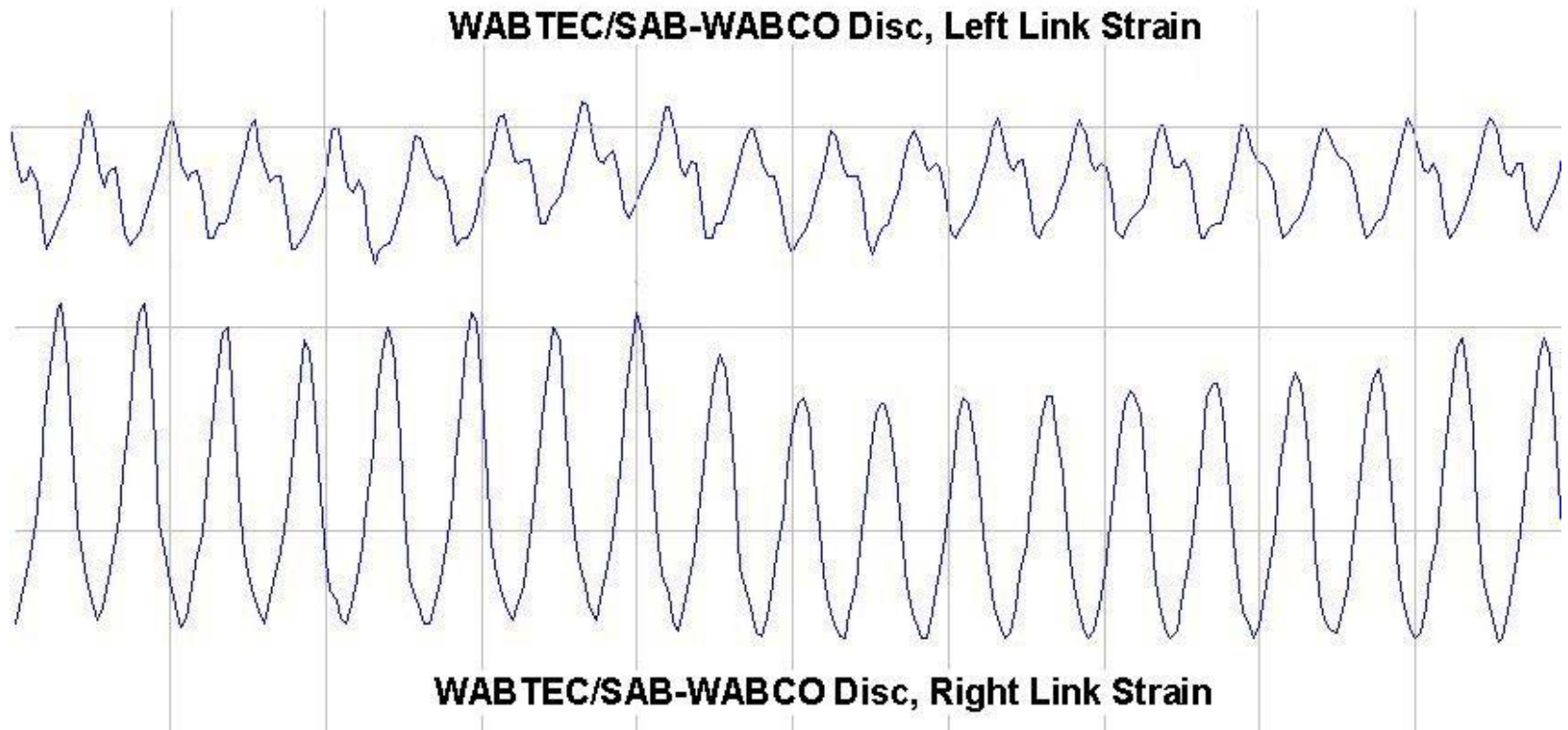

June 17–File 25–559 Seconds Braking

Sustained Oscillation Instrumented Axle In Lead

PSD of WABTEC/SAB-WABCO Left Link Strain, 16384 points, 5 point moving avg

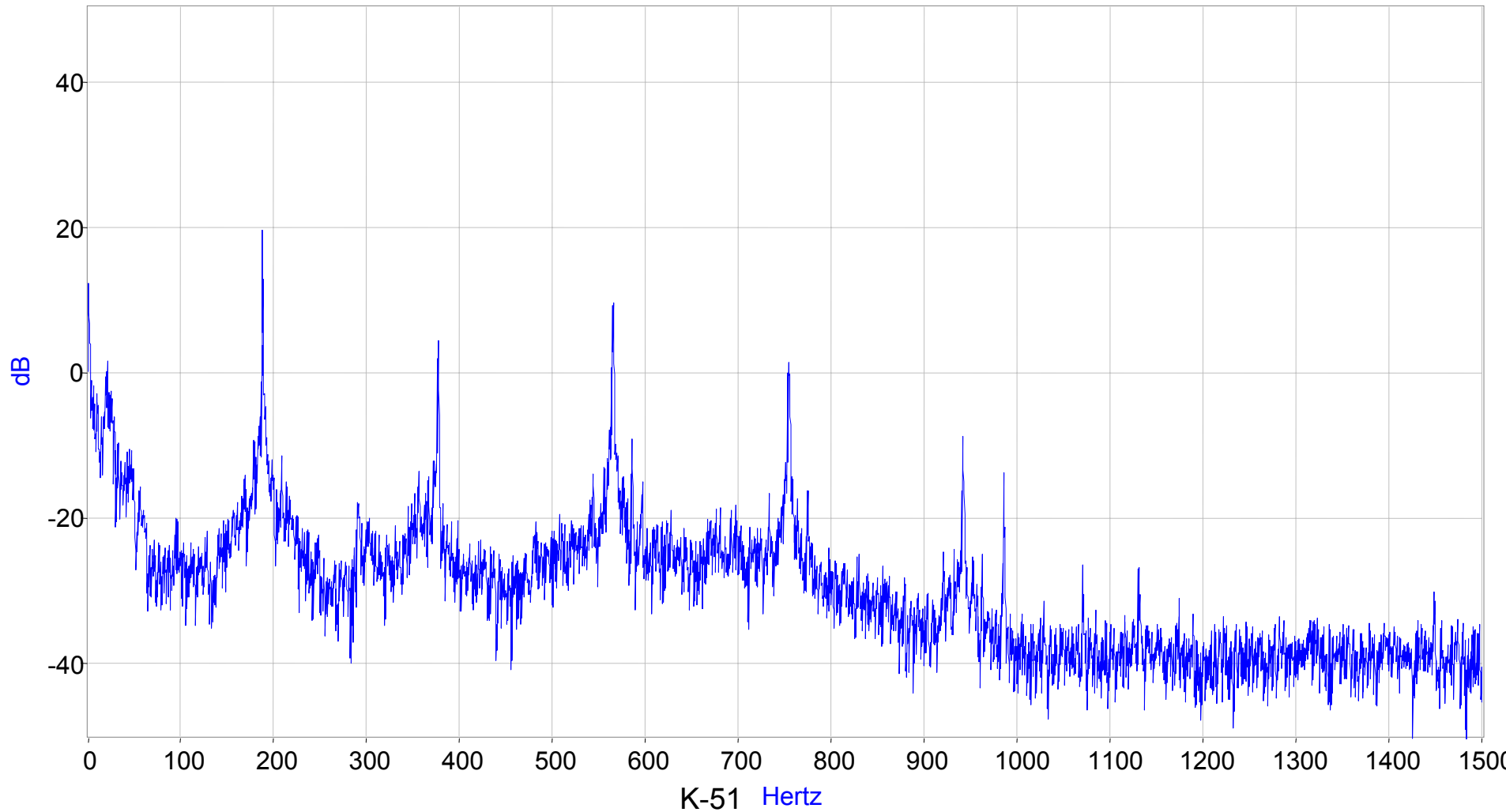

June 17–File 25–559 Seconds Braking

Sustained Oscillation Instrumented Axle In Lead

PSD of WABTEC/SAB-WABCO Right Link Strain, 16384 points, 5 point moving avg

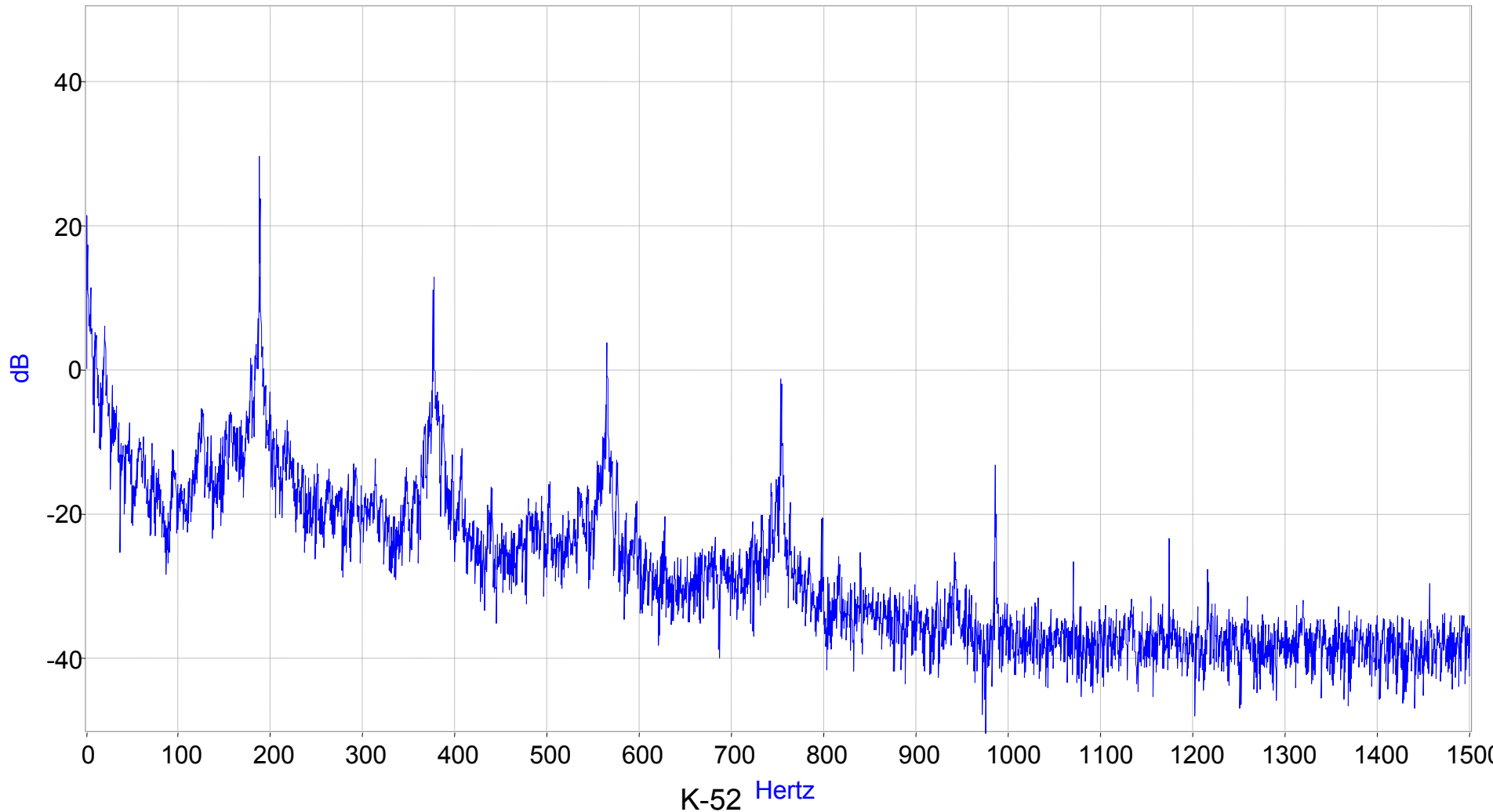

June 17–File 25–559 Seconds Braking

Sustained Oscillation Instrumented Axle In Lead

Date/File/Time	Sustained Oscillation	Axle	Harmonic Content	Strain Change
June 16 – File 18 - 375	No	Trail	No	Tension

Date/File/Time	Sustained Oscillation	Axle	Left Link Microstrain	Right Link Microstrain
June 17 – File 25 - 559	Yes	Lead	-17	-189

Observations

- No Sustained Oscillations
 - Small Dynamic Link Strains
 - No Harmonic Link Content
 - Brake Links In Compression Or Tension
- Sustained Oscillations
 - Only Observed When Brake Links In Compression
 - Large Dynamic Link Strains
 - Harmonic Content–Fundamental Frequency
~ 187 Hz
 - May Indicate Stick-Slip Behavior

Observations

- The Two Links Show Some Similar Behaviors:
 - Both Demonstrate Same Direction Of Strain Change
 - Both Have Similar Shape In The Time Domain
- Left Link
 - Larger Than Right Link For Tension (Trailing Axle) By Factor Of 6
- Right Link
 - Larger Than Left Link For Compression (Leading Axle) By Factor Of 7 To 10

Table K.2. Brake Link Data Analyzed

Date/File/Time	Sustained Oscillation	Axle	Harmonic Content	Strain Change
June 16–File 18 - 375	No	Trail	No	Tension
June 18–File 24 - 310	No	Lead	No	Compression
June 18–File 24 - 580	Yes	Lead	Yes	Compression
June 17–File 25 - 559	Yes	Lead	Yes	Compression

Table K.3. Summary Of Brake Link Strains

Date/File/Time	Sustained Oscillation	Axle	Left Link Microstrain	Right Link Microstrain
June 16–File 18 - 375	No	Trail	+130	+21
June 18–File 24 - 310	No	Lead	-32	-231
June 18–File 24 - 580	Yes	Lead	-32	-221
June 17–File 25 - 559	Yes	Lead	-17	-189

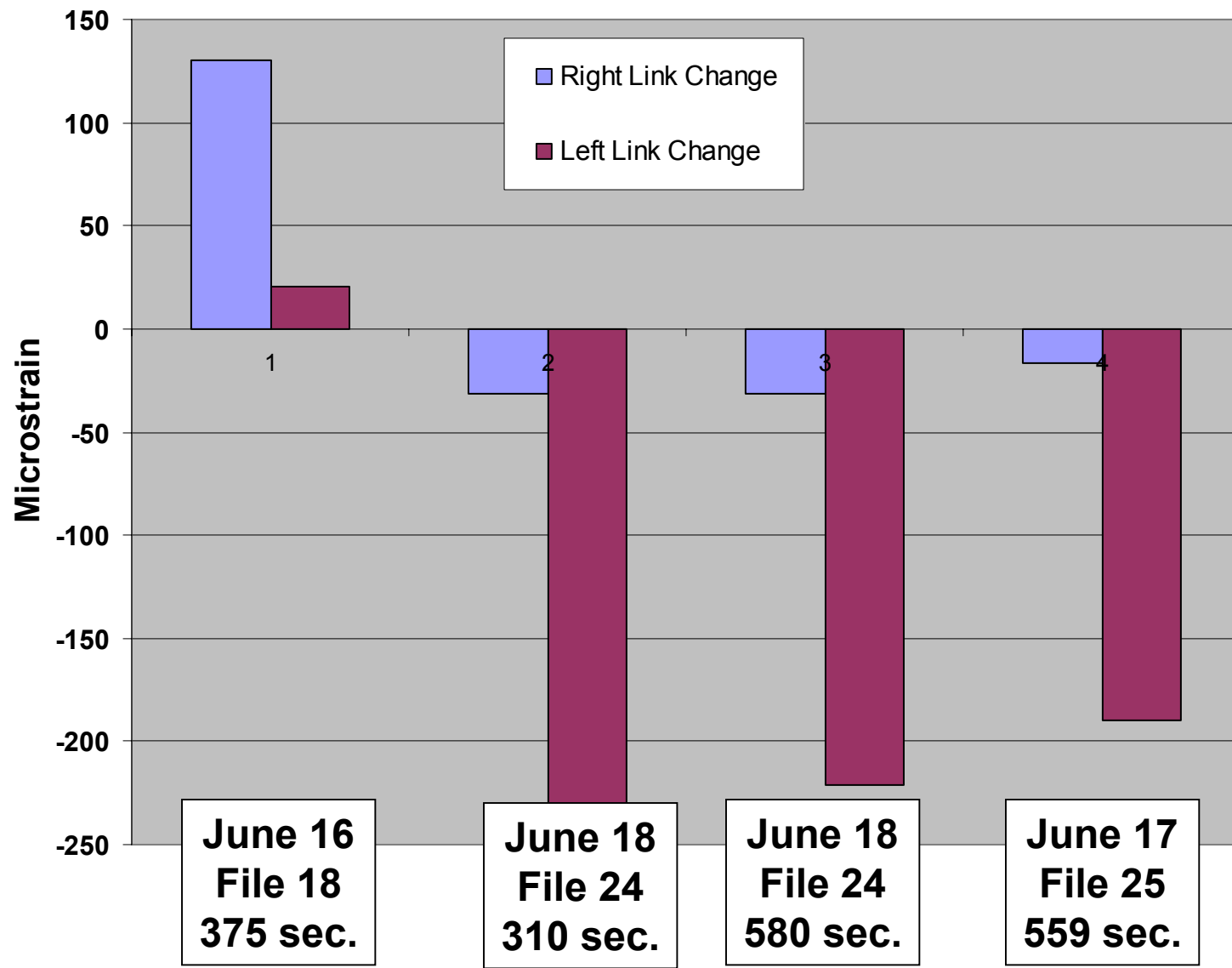

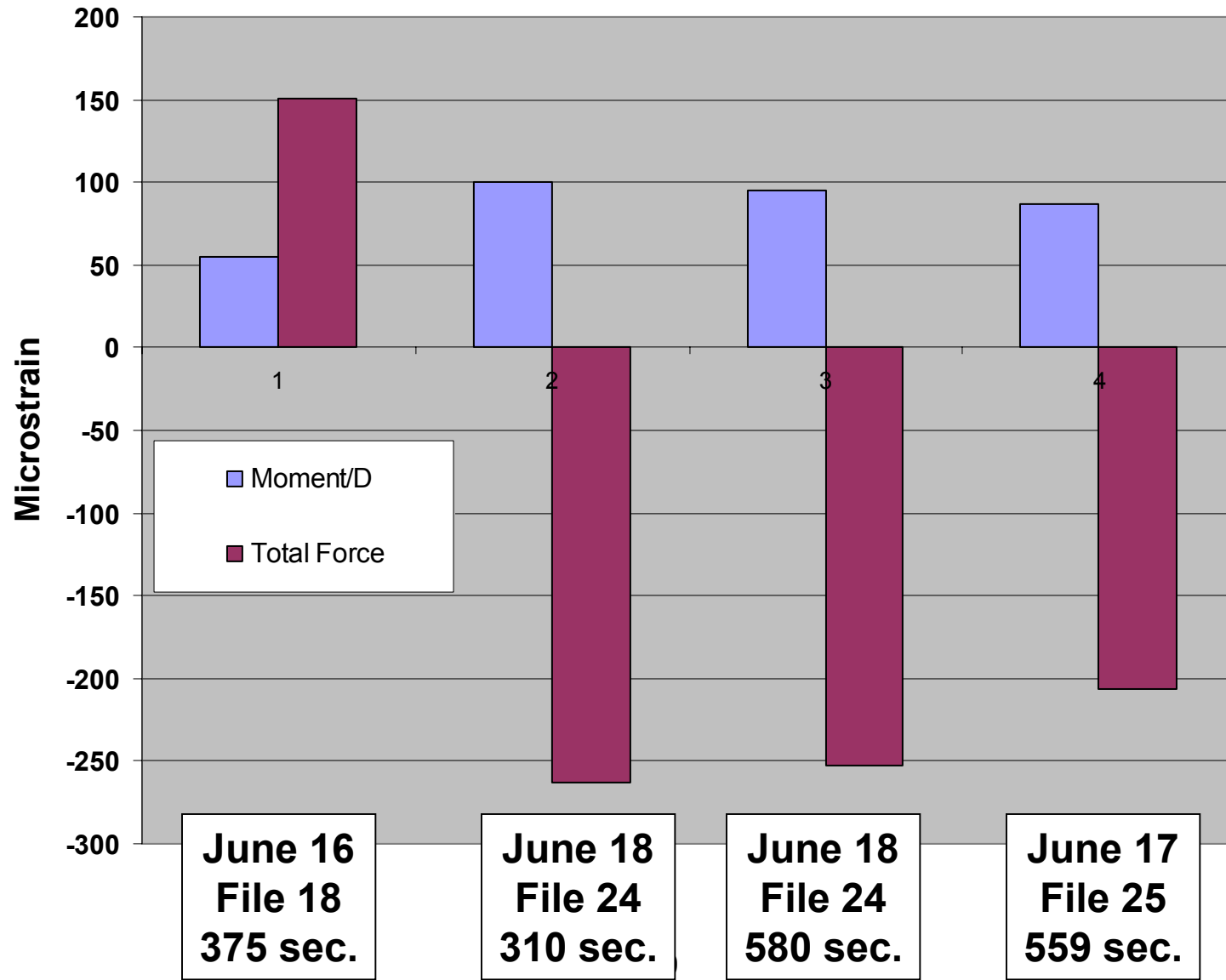

Appendix L. Daily Handouts

Handouts provided during each test are available on CD-ROM upon request. Please direct requests to the following:

**ENSCO, Inc.
ATE Division
5400 Port Royal Road
Springfield, VA 22151**

Telephone: 703-321-4475

**Appendix M.
Background of the WABTEC/SAB-WABCO
Supplied Brake Disc**

(Prepared by Faiveley Transport)

Residual Compressive Stresses in Spokes

- Compressive stresses level in used disc defined by assembly process of disc on axle and due to shrinking effects of friction ring caused by yielding in friction surface
- The compressive stress caused by the assembly process depends on the interference fit between axle and hub
- The compressive stress caused by the shrinking of the friction ring depends on the overall temperature level as well as on the differences in the friction surface e.g. caused by hot spots
- The overall compressive stress level stabilizes during service before yielding point

Residual Compressive Stresses in Spokes

- Example for the development of compressive strains based on the measurement at the spoke during dynamometer test at Faiveley Transport (see dynamometer test report V/V98-101-Rev00)

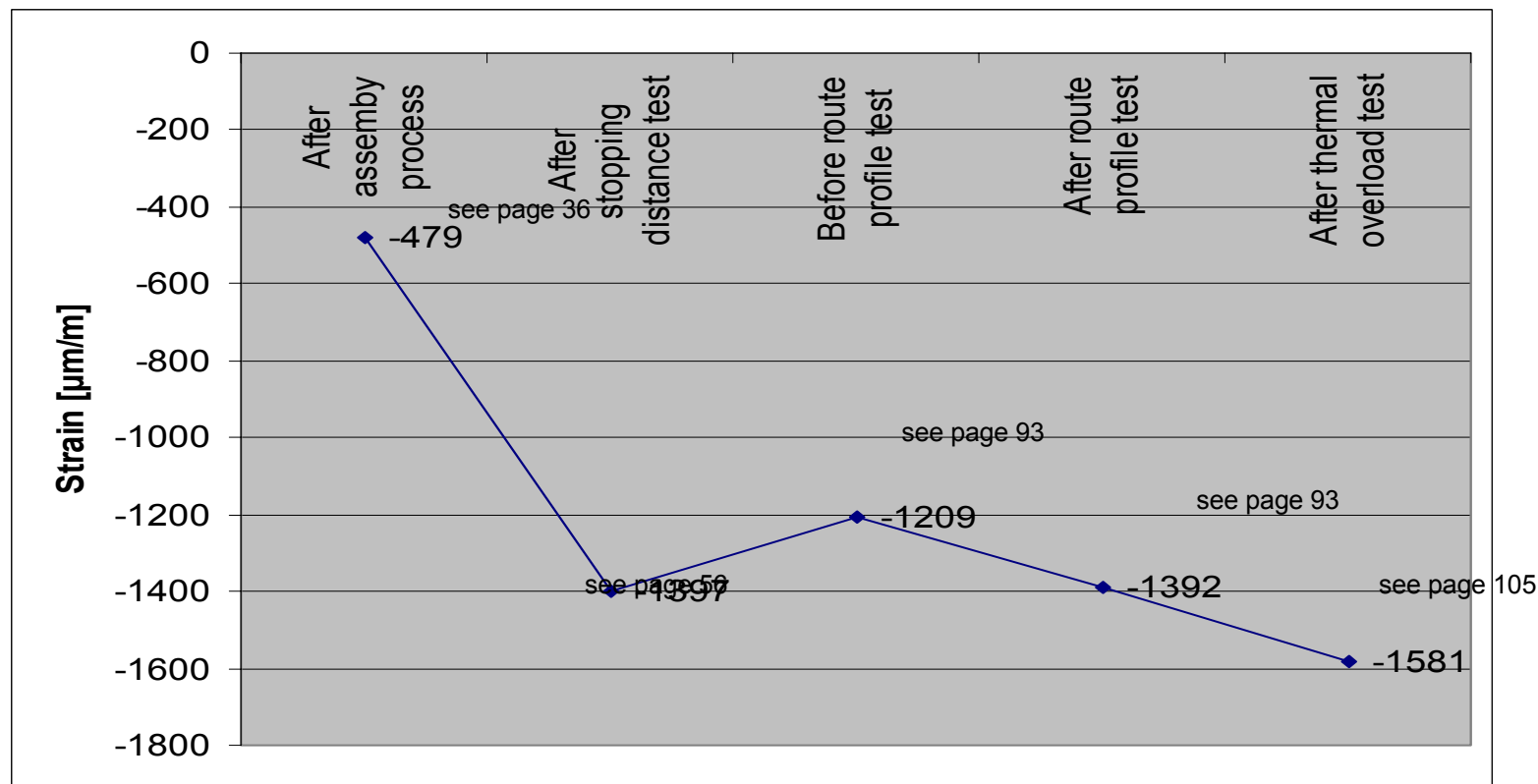

Note: Increase after stopping distance test and start of route possibly caused by external influences (temperature @ measurement, slight shifting in strain gauge, etc.)

Design Principle

- The principle design consideration for the brake disc was the high thermal load resistance of the monoblock disc as required by the specification. The design of the Acela monoblock brake disc and especially the spoke design had to be adapted to this requirement.
- The basis for this design option is the fact that the thermal expansion of the friction ring is related to a certain dimension.
- The basis for this design option is the fact that the thermal expansion of the friction ring and the loads on the spokes are related to certain dimension, i.e. the elongation of the spoke is defined by the geometrical value of the expansion of the friction ring.
- The elongation of the spoke is defined by the geometrical value of the expansion. Therefore the stress level in the spoke from thermal expansion depends directly on the length of the spoke.
- To resist the high thermal requirement the spokes length has been increased to reduced the stress level caused by the thermal expansion of the friction ring.
- By increasing the spoke length, the stress level in the spoke could be reduced significantly against a more rigid fixing of the spoke e.g. at the inner diameter of the friction ring.
- To support the minor influence of the specified lateral shocks, a web has been applied to the spoke in lateral direction to increase the stiffness against the specified lateral shock.
- To increase the strength and resistance a tempered cast steel material has been chosen as the brake disc material.

3

Design Principle

- Theoretical background for stress level by thermal expansions

$$\varepsilon = \Delta l / l_0$$

where:

ε = strain at the spoke

l_0 = "normal" spoke length

Δl = elongation of the spoke by thermal expansion of the friction ring

$$\sigma = \varepsilon * E$$

where:

σ = nominal stress level in spoke

ε = strain at the spoke

E = modulus of elasticity

- The length, size and the connection of the spoke to the friction has a significant influence on the overall tensile stress level caused by thermal expansion because the elongation of the spoke is geometrical defined by expansion of the friction ring.
- For example a spoke with approx. 25% shorter length would lead to at least 40% more strains caused by thermal loads

Design verification process

- The brake disc design has been validated by a theoretical and practical approach utilizing common tools, such as the FEA calculation, dynamometer tests, vehicle test, etc.
- A first preliminary internal FEA calculation was completed in 1996 for the initial design discussion for the Acela axle mounted disc. After the internal reviews of this design, comments led to a revision of the design and an updated FEA calculation in 1997. The revised and updated FEA calculation was summarized in a final report (see document V/A97-092 Rev00) and formed the basis for the final proposal for the disc design. Based on this proposal the design was been jointly accepted.
- The evaluation of the FEA has been realized acc. to Smith, Watson and Topper by applying an S/N-curve and the corresponding damaging factor P_{SWT} . The evaluation of the FEA shows no indication for concern even under the assumed unrealistic scenarios.
- The dynamometer test simulated various load conditions such as the route profile under service load condition and continuously overload conditions. Also the dynamometer test shows no indication for concern even under the applied overload conditions.
- A vehicle testing has been performed confirming the results from the previous verification process and also here no indication for concern could be detected.
- Based on the verification process the disc has been jointly accepted for the use in the Acela vehicles.

TECHNICAL DEFINITIONS

	Definition
Cant Deficiency	For a train traveling through curved track at a given speed, the cant deficiency is the additional height that the elevated rail would have to be raised in order to produce a condition in which there is no net lateral force exerted on the rail.
Decibels	A unit for expressing the ratio of two amounts of electric or acoustic signal power equal to 10 times the common logarithm of this ratio
Truck/Bogie	Swiveling carriage consisting of a frame, two pairs of wheels and a collection of springs used to carry and guide one end of a railroad car during navigating over railroad tracks

ACRONYMS AND ABBREVIATIONS

	Acronym and Abbreviation
Amtrak	National Passenger Railroad Administration
Axle 1	Test axle with the WABTEC/SAB-WABCO supplied discs on Coach 3413; Axle 1 on A-end truck adjacent to Power Car 2038
Axle 2	Test axle with the Knorr discs on Coach 3534; Axle 4 on B-end truck adjacent to Coach 3413
BIP	Bending of spokes in-the-plane of the disc
BOP	Bending of spokes out-of-the-plane of the disc
DB	Decibels
°F	Temperature measured in degrees Fahrenheit
F₁	Strain Gage in plane face of spoke facing Spoke 1
F₂	Strain Gage in plane face of spoke facing Spoke 5
Faiveley	Faiveley Transport
FEA	Finite element analysis
FRA	Federal Railroad Administration
g	Acceleration of gravity
GPS	Global Positioning System
IR	Infrared
Knorr	Knorr Brake Corporation
MP&E	Motive power and equipment
MPH, mph	Miles per hour
MTI	Metallurgical Technologies, Inc., P.A.
NEC	Northeast Corridor
NECMSC	Northeast Corridor Maintenance Services Company
PSD	Power Spectral Density; describes how the variance, or power, of a time series is distributed as a function of the different frequencies that form the signal
PSI, psi	Pounds per square inch
R₁	Strain Gage on out of plane face of spoke 6 (nut side)
R₂	Strain Gage on out of plane face of spoke 6 (opposite nut side)
SO	Sustained Oscillation
Spoke Number	Spoke naming convention
E	Strain
W/S-W	WABTEC/SAB-WABCO Supplied
Wabtec	Wabtec Corporation
μE, με	Microstrain - Strain times 10 ⁶

