

202,272

# STUDY OF NEW TRACK STRUCTURE DESIGN

## PHASE I

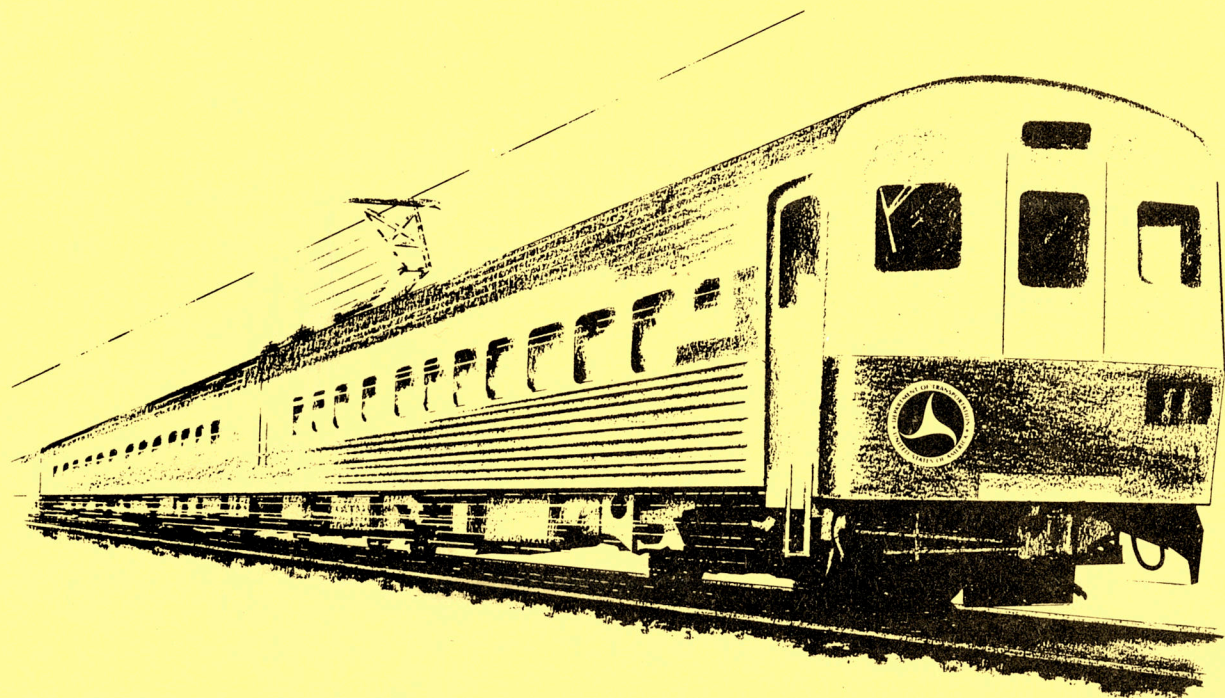

**FEDERAL RAILROAD ADMINISTRATION**  
**OFFICE OF HIGH-SPEED GROUND TRANSPORTATION**

01-Track & Structures

1. Report No. FRA-RT-72-12		2. Government Accession No.		3. Recipient's Catalog No.	
4. Title and Subtitle Study of New Track Structure Design Phase I			5. Report Date September 1966		
			6. Performing Organization Code		
7. Author(s) H.C. Meacham, J.E. Voorhees, J. G. Eggert, et al			8. Performing Organization Report No.		
9. Performing Organization Name and Address Battelle Memorial Institute 505 King Avenue Columbus, Ohio 43201			10. Work Unit No.		
			11. Contract or Grant No.		
12. Sponsoring Agency Name and Address Engineering, Research & Development Division Federal Railroad Administration Washington, D.C. 20591			13. Type of Report and Period Covered Preliminary Report		
			14. Sponsoring Agency Code		
15. Supplementary Notes					
16. Abstract  <p>Conventional (tie-type) and non-conventional rail vehicle track structures were studied with the constraint that standard gage and rail head contour not be varied from current practices. Computer programs were developed and used to analyze track response to both static and dynamic vehicle loading. A major philosophy in the development of improved track structures was to reduce the magnitude and number of pressure cycles transmitted to the foundation by passing rail vehicles.</p> <p>This report contains detailed discussion of material summarized in: "Studies For Rail Vehicle Track Structures," PB 149 139, and is a reference source cited in that document.</p>					
17. Key Words Track structure designs, improved track stability, track response computer programs, soil deterioration factor.			18. Distribution Statement Availability is unlimited. Copies may be purchased from the National Technical Information Service, Springfield, Va. 22151, for \$3.00 a copy.		
19. Security Classif. (of this report)		20. Security Classif. (of this page)		21. No. of Pages	22. Price



TABLE OF CONTENTS

	<u>Page</u>
INTRODUCTION . . . . .	1
SCOPE OF RESEARCH INVESTIGATION . . . . .	2
Stated Program Objective . . . . .	2
Basic Design Approach . . . . .	2
Major Technical Studies . . . . .	3
Structural Design Criterion . . . . .	3
Resilient Rail Support . . . . .	3
Rails and Attachment Fittings . . . . .	4
SUMMARY . . . . .	5
RECOMMENDED TRACK STRUCTURES . . . . .	7
Recommended Track Structure 1--Twin Reinforced Concrete Beam . . . . .	7
Recommended Track Structure 2--Reinforced Concrete Slab . . . . .	9
Recommended Track Structure 3--Twin-Composite Beam . . . . .	13
Recommended Track Structure 4--Twin Steel Beam . . . . .	17
DISCUSSION OF TRACK STRUCTURES . . . . .	21
Initial Construction Costs . . . . .	21
Adaptability to Variable Roadway Conditions . . . . .	23
Track Alignment Standards . . . . .	25
Track Installation Tolerances . . . . .	26
Electrical Characteristics . . . . .	28
Signaling . . . . .	28
Propulsion . . . . .	30
Communications . . . . .	30
FUTURE WORK . . . . .	31
Detailed Design, Analysis, and Refinement of One or More of the Recommended Track Structures . . . . .	31
Construction, Laboratory Testing, and Evaluation of Portions of the Track Structures . . . . .	31
Construction, Field Tests, and Evaluation of the Track Structures Under Actual Rail Traffic . . . . .	32
TECHNICAL WORK . . . . .	33
Description and Analysis of Present Track Structure . . . . .	33
Past Efforts at Improvement of the Track Structure . . . . .	35
Basic Future Improvements Desired . . . . .	36
Forces Acting on the Track Structure . . . . .	36
Mechanics of Transferring Wheel Loads to the Soil . . . . .	39

TABLE OF CONTENTS (continued)

	<u>Page</u>
Properties of Soil, Including Effects of Cyclic Loads and Moisture Content . . . . .	46
Effect of Moisture on Soil Properties . . . . .	46
Effect of Cyclic Loading . . . . .	47
Effects of Magnitude and Frequency of Soil Pressure on Settlement . . . . .	48
Design Criterion for Track Structures for High-Speed Trains Based on Allowable Time-Varying Soil Pressures . . . . .	51
Predicting Settlement Rate of Soil . . . . .	51
Approximate Pressure-Time Curve . . . . .	53
Approximate Settlement Rate . . . . .	53
Reference System . . . . .	55
Preliminary Designs for Track Support Structure . . . . .	61
Concrete Support Structures . . . . .	61
Composite Steel-Concrete Support Structures . . . . .	63
All-Steel Support Structures . . . . .	64
Refinement of Reinforced Concrete Structure Designs . . . . .	65
Selection of Final Reinforced Concrete Structure Designs . . . . .	69
Control of Soil Moisture . . . . .	70
Some Specific Drainage Structures . . . . .	73
Analysis of Resilience of Track Structures . . . . .	75
Digital Computer Program for Static Deflections . . . . .	75
Analog Computer Simulation for Dynamic Response . . . . .	81
Conclusions Regarding Resilience . . . . .	97
Rail and Rail Attachment Devices . . . . .	98
Rail Design . . . . .	99
Rail Support and Attachment Devices . . . . .	102
REFERENCES . . . . .	117, 118

APPENDICES

A - DETAILED COST BREAKDOWN FOR FOUR RECOMMENDED BEAM STRUCTURES AND FOUR RECOMMENDED RAIL-FASTENER ASSEMBLIES . . . . .	A-1
B - CALCULATION OF STRESSES IN STEEL-CONCRETE COMPOSITE BEAM TRACK STRUCTURE . . . . .	B-1

LIST OF FIGURES

<u>Figure</u>		<u>Page</u>
1	Twin-Reinforced Concrete Beams With Double-Headed Rails . . . . .	8
2	Two-Headed Rail and Fastener . . . . .	10
3	Reinforced-Concrete Slab Track Structure Using Neoprene-Encapsulated Rail . . . . .	11
4	Encapsulated Rail Design Featuring Reversible Rail Mounted Resiliently in Concrete . . . . .	14
5	Composite Track Structure Using Twin Steel-Concrete Beams With Welded Studs for Shear Connectors and Rail Attachment . . . . .	15
6	Attachment Device for Standard Rail . . . . .	16
7	Twin Steel Beam Track Structure Shown with Special Replaceable-Head Rail . . . . .	18
8	Replaceable-Head Rail Design . . . . .	19
9	Plot of Structure Deflection Versus Soil Modulus . . . . .	27
10	Sketch Showing Steel Beam Tolerance Buildup . . . . .	28
11	Typical Track Electrical Circuit . . . . .	29
12	Electrical Circuit for Track Without Insulated Joints . . . . .	30
13	Conventional Railroad Track . . . . .	34
14	Typical Stiffness Values of Conventional Track Assembly . . . . .	40
15	Pressure Distribution at Various Depths Beneath Ties . . . . .	41
16	Rail Deflection Shape for a Static Point Load . . . . .	43
17	Effects of Rail Size and Foundation Stiffness on Track Structure . . . . .	44
18	Typical Pressure-Time Curve for Pressure Directly Under a Tie of a Conventional Track Structure . . . . .	45
19	Effect of Soil Moisture on Volume . . . . .	46
20	Properties of Soil Under Cyclic Loading . . . . .	47
21	Rate of Settlement of Soil as a Function of the Applied Frequency of a Constant Magnitude Pressure . . . . .	49

LIST OF FIGURES (continued)

<u>Figure</u>		<u>Page</u>
22	Pressure-Time Curve Experienced by Soil Beneath a Fairly Rigid Track Structure (No Pressure Fluctuations for Individual Wheels ) . . . . .	50
23	Two Different Track Structures Which Yield Similar Soil Pressure-Time Curves . . . . .	52
24	Approximate and Actual Pressure-Time Curve . . . . .	54
25	Variation of Static Soil Pressure Under Different Points of Budd Car with Relative Stiffness of Rail and Elastic Foundation . . . . .	57
26	Design Criterion Curve for Sizing Track Structure on the Basis of Time-Varying Soil Pressure . . . . .	59
27	Soil-Pressure-Time Curves for Track Structures of Different Widths and Rigidity (Soil Modulus, $k_o = 500 \text{ lb/in.}^3$ ) . . . . .	60
28	Effect of Distribution of Reinforcing Rods on Position of Neutral Axis of a Concrete Beam in Bending . . . . .	68
29	Drainage Structure . . . . .	76
30	Proposed Earthwork Base for Track Structure . . . . .	77
31	Static Deflections Calculated by Digital Computer Program Including Effects of Resilient Pad . . . . .	79
32	Maximum Bending Moment in Rail and Beam for Different Rail Pads . . . . .	82
33	Lumped Parameter Model of Wheels Supported by Track and Roadbed . . . . .	87
34	Lumped Parameter Model of Wheels Supported by Rails, Soft Resilient Pads, a Track Foundation, and a Roadbed . . . . .	87
35	Lumped Parameter Model Representing Portion of Car and Track Structure Associated With One Truck . . . . .	89
36	Car Body Acceleration Response of 4 Track Structures to Sinusoidal Profile Error . . . . .	92
37	Response of Track Structure, Using Sinusoidal Profile Input . . . . .	93
38	Effects of Rail Pad Stiffness on Response of Car and Track to a 1/4-inch Step in the Rail Profile . . . . .	94

LIST OF FIGURES (continued)

<u>Figure</u>		<u>Page</u>
39	Design Concepts for Nonstandard Rails . . . . .	101
40	Encapsulated Rail Design Featuring Reversible Rail Mounted Resiliently in Concrete . . . . .	104
41	Design Concepts for Adjustable Rail Attachment Devices . . . . .	108
42	Rail Attachment to Beam Structure . . . . .	110
43	Attachment Device for Standard Rail . . . . .	111
44	Eccentric Inserts for Adjusting and Holding Rail Laterally . . . . .	112
45	Two-Headed Rail and Fastener . . . . .	114
46	Concept for Three-Headed Rail and Attachment Device . . . . .	116
B-1	Converting a Composite Beam Into an All-Steel Beam . . . . .	B-3



LIST OF TABLES

<u>Table</u>		<u>Page</u>
1	Estimated Costs for Installed Track Structures Per Single Track Mile . . . . .	22
2	Parameters of Various Reinforced Concrete Track Structures .	66
3	Soil Characteristics . . . . .	71
4	Results of Digital Computer Program . . . . .	80
5	System Parameters of Four Different Track Structures Investigated in Analog Computer Simulation of Car and Track .	90
6	Results of Analog Computer Program with Step Input . . .	96

LIST OF SYMBOLS

- $A$  = cross-sectional area, in.<sup>2</sup>  
 $A_{SB}$  = area of steel reinforcing rods at bottom of concrete beam foundations, in.<sup>2</sup>  
 $A_{ST}$  = area of steel reinforcing rods at top of concrete beam foundations, in.<sup>2</sup>  
 $C_{RR}$  = lumped rail-roadbed damping, lb-sec/in.  
 $C_{RP}$  = lumped rail-pad damping, lb-sec/in.  
 $C_{BS}$  = lumped beam structure-soil damping, lb-sec/in.  
 $C_B$  = bearing sleeve damping, lb-sec/in.  
 $C_{SP}$  = lumped bolster-spider shock pad damping, lb-sec/in.  
 $C_s$  = lumped car body suspension damping, lb-sec/in.  
 $D$  =  $d/dt$  (differential operator), sec<sup>-1</sup>  
 $E$  = Young's modulus of elasticity, lb/in.<sup>2</sup>  
 $F$  = force, lb  
 $H$  = hydraulic head, in. water  
 $dH/dx$  = hydraulic head gradient, dimensionless  
 $I$  = area moment of inertia, in.<sup>4</sup>  
 $I_S$  = area moment of inertia of an all-steel or equivalent all-steel section, in.<sup>4</sup>  
 $J_T$  = mass moment of inertia for the truck of the Budd car in the plane of the rail, in.-lb-sec<sup>2</sup>  
 $K$  = soil foundation stiffness per unit length, lb/in./in.  
 $K_P$  = resilient pad foundation stiffness per unit length, lb/in./in.  
 $L$  = distance between wheels on the same rail, in.  
 $L_e$  = pitch length of simulated sinusoidal rail profile error, in.  
 $L_R$  = effective rail length of lumped parameter system model, in.  
 $M$  = bending moment, in.-lb  
 $M_R$  = bending moment in rail, in.-lb

LIST OF SYMBOLS (continued)

- $M_B$  = bending moment in beam structure beneath rail, in.-lb  
 $P$  = static wheel load = 1/8 car weight, lb  
 $Q$  = soil moisture flow volume, in.<sup>3</sup>  
 $R$  = radius of train wheel, in.  
 $T$  = temperature, F  
 $V$  = velocity of train, in./sec, mph  
 $V_C$  = critical velocity, in./sec, mph  
 $W$  = width of structure resting on soil, in.  
 $EI_R$  = flexural rigidity of rail, lb-in.<sup>2</sup>  
 $EI_B$  = flexural rigidity of beam structure beneath rail, lb-in.<sup>2</sup>  
 $N$  = distance from neutral axis to compressed surface of concrete beam for positive bending moments, in.  
 $d$  = distance from neutral axis to extreme stressed fiber of a beam in bending, in.  
 $f$  = circular frequency, cps  
 $f_1, f_2$  = circular frequencies of the two components in the approximate soil pressure-time curve, cps  
 $f_n$  = natural frequency, cps  
 $f(x)$  = function of  $x$   
 $h$  = height of reinforced concrete beam from top surface to bottom reinforcing rod, in.  
 $k_o$  = soil foundation bulk modulus, lb/in.<sup>3</sup>  
 $k_R$  = rail stiffness (for rail length  $L_R$ ), lb/in.  
 $k_p$  = pad stiffness, lb/in.  
 $k_{RP}$  = rail-pad lumped stiffness, lb/in.  
 $k_{RR}$  = rail-roadbed lumped stiffness, lb/in.  
 $k_{BS}$  = beam structure-soil lumped stiffness, lb/in.  
 $k_{WR}$  = wheel-rail contact stiffness, lb/in.

LIST OF SYMBOLS (continued)

$k_B$  = bearing sleeve stiffness, lb/in.

$k_{SP}$  = bolster-bolster pad stiffness, lb/in.

$k_S$  = car body suspension stiffness, lb/in.

$l$  = characteristic length of train wheel load spacing  
= 1/2 truck wheelbase = 51 in.

$m$  = mass, lb-sec<sup>2</sup>/in.

$m_c$  = mass of half of car body, lb-sec<sup>2</sup>/in.

$m_r$  = mass of rail per unit length, lb-sec<sup>2</sup>

$m_R$  = mass of rail for length  $L_R$ , lb-sec<sup>2</sup>

$m_{RR}$  = rail-roadbed lumped mass, lb-sec<sup>2</sup>/in.

$m_{RP}$  = rail-pad lumped mass, lb-sec<sup>2</sup>/in.

$m_{BS}$  = rail-beam structure lumped mass, lb-sec<sup>2</sup>/in.

$n$  = distance from neutral axis to compressed surface of concrete beam for negative bending moments, in.

$p$  = soil pressure, psi

$q$  = hydraulic permeability, in./sec

$r$  = frequency ratio,  $f/f_n$ , dimensionless

$s$  = soil settlement rate

$t$  = time, sec

$x$  = independent variable distance along rail from point of wheel load application, in.

$y(x)$  = static deflection as a function of  $x$ , in.

$y_R(x)$  = static deflection of rail in digital computer program, in.

$y_B(x)$  = static deflection of beam structure in digital computer program, in.

$y_{BC}$  = static deflection of track beneath "Between Cars" point on train, in.

$y_{MT}$  = static deflection of track beneath "Mid-Truck" point on train, in.

$y(t)$  = dynamic deflections pertaining to wheel on same truck and sharing same rail with  $z(t)$  group, in.

LIST OF SYMBOLS (continued)

$z_c(t)$  = dynamic deflection of 1/2 car body supported by one truck, in.

$z_b(t)$  = dynamic deflection of bolster of truck, in.

$z_T(t)$  = dynamic deflection of truck and its side frames, in.

$z_W(t)$  = dynamic deflection of wheel (centerline), in.

$z_{WR}(t)$  = dynamic deflection of wheel surface, in.

$z_R(t)$  = dynamic deflection of rail, in.

$z_B(t)$  = dynamic deflection of beam structure and soil beneath rail, in.

$\alpha(x)$  = shape of deflection of rail under point load at  $x = 0$ ; ratio of deflection at  $x$  to deflection at  $x = 0$ , dimensionless

$\beta$  = rail-elastic foundation relative stiffness parameter, in.<sup>-1</sup>

$\gamma$  = ratio of allowable tensile stress in steel reinforcing rods to allowable compressive stress in concrete, dimensionless

$\delta$  = height of step function track profile error simulation, in.

$\epsilon$  = peak-to-peak amplitude of sinusoidal rail profile error simulation, in.

$\theta$  = pitch (angular rotation in plane of rail) of truck, radians

$\lambda$  = ratio  $A_{ST}/A_{SB}$ , dimensionless

$\mu$  = magnification factor, dimensionless

$\tau_1, \tau_2$  = time periods of soil pressure waves beneath moving train, sec.

$\varphi(t)$  = track profile error simulation function, in.

$\psi$  = dynamic impact factor, dimensionless

$\omega$  = angular forcing frequency, sec<sup>-1</sup>

$\omega_e$  = angular frequency of sinusoidal track profile error simulation, sec<sup>-1</sup>

$\omega_n$  = angular natural frequency of system =  $2\pi f_n$ , sec<sup>-1</sup>

$\sigma_{ST}$  = maximum tensile stress in steel reinforcing rods, psi

$\sigma_{CON}$  = maximum compressive stress in concrete, psi

$\infty$  = infinity

LIST OF SYMBOLS (continued)

BC = between cars

IA = under inside axle of truck

MT = mid-truck

OA = under outside axle of truck

MC = mid-car.



## STUDY OF NEW TRACK STRUCTURE DESIGNS

### INTRODUCTION

This research investigation was undertaken for the Department of Commerce by Battelle Memorial Institute for the express purpose of conceiving new and improved track structures for high-speed trains. The need for improved track structures is believed to be one of the leading technical and economic problems involved with the development of safe, comfortable, high-speed passenger train service.

Specific features to be incorporated in such improved track structures include provisions for accurate leveling and alignment of the rails at the time of construction; long-term dimensional stability and freedom from the requirement for maintenance in spite of heavy, high-speed traffic and various soil conditions; and provisions for positive readjustment of rail alignment and elevation should the need develop. The ground rules under which this program was conducted specified only that the standard railhead contour and gauge should be retained, so that standard rolling stock could operate on all new track systems recommended.

A considerable amount of time has elapsed since this project was completed and this report was drafted. During this time additional analyses of other track structures and specific fasteners have been made, and hopefully this general program of track structure analysis will continue to the point where selected advanced track structures are installed in the field and evaluated.

Therefore, due to the fact that the work reported herein can be considered as the first phase of a broader track structure analysis program, and due to the size and detail of this report, it can be considered as a preliminary or interim report which will be supplemented by a more concise but broader report covering the track structure program. This program will include the validation of the dynamic response of the track structures as determined by comparing field data with computer data.



SCOPE OF RESEARCH INVESTIGATIONStated Program Objective

The objective of the subject as stated in the request for proposal was to generate new ideas and designs for railroad track structures which can either:

- (1) Provide an inherently more stable ride for a train, and/or
- (2) Be more easily and economically installed or maintained in alignment than existing track structure designs.

The criteria against which the various track structure designs were to be evaluated were specified in the request for proposal, as follows:

- (1) Performance
  - (a) Safety--assurance against derailment
  - (b) Ride quality--control of track geometry
  - (c) Durability--heavy loads at high speeds
  - (d) Effect on other elements of track structure
- (2) Convenience
  - (a) Adaptability to variable roadway conditions
  - (b) Electrical characteristics--signals/communications, propulsion
  - (c) Installation and maintenance
- (3) Economy
  - (a) Initial expense
  - (b) Maintenance costs, including replacement
  - (c) Salvage value.

Basic Design Approach

Examination of the criteria by which track structure designs are to be evaluated shows that many of them can be met by a track structure having the following characteristics:

- (1) It must be capable of being built or installed with accurate original alignment
- (2) It must possess the structural integrity and dimensional stability to maintain this alignment over long time periods
- (3) It must include positive provisions for the adjustment of rail elevation and alignment so that the original accuracy can be re-established when necessary.

The basic approach considered appropriate for meeting the objective of a stable track structure was to consider it as an engineering problem in which the first step is to make a force analysis to determine the forces and loads imposed on the structure. Following this, all components were designed to withstand repeated loadings with no permanent deformation or fracture. The structure resulting from this approach is significantly different than a conventional track structure in which substantial motion of the ties and ballast occurs under dynamic wheel loads.

### Major Technical Studies

#### Structural Design Criterion

A considerable portion of the project was devoted to the design of a supporting structure or foundation beneath the rail which would be as stable as possible, taking into consideration the fact that the ultimate support for the structure must be provided by the soil or other subgrade material. A design criterion was developed to enable various designs for supporting structures to be compared with one another and with conventional track structures in terms of the frequency and magnitude of pressure transmitted to the soil. It was found that the foundation stiffness required to prevent excessive soil pressure was the overriding factor in the foundation design, rather than stress levels. Therefore, bending stress levels in the recommended track structures are quite low, although stresses due to thermal expansion and contraction are significant.

#### Resilient Rail Support

A second important portion of this project was concerned with an analysis of the effects of a resilient member (such as a rubber pad) between the rail and its supporting structure. If for no other reason, some compressible member is needed to insure good bearing pressure distribution from the rail to the structure, and some benefits such as reduced noise and vibration, and increased electrical insulation are commonly cited for a resilient member. What was not known, however, was the effect of varying degrees of resilience on the car ride at high speeds.

Two computer programs were used to evaluate the effect of resilience. The first was a digital computer program which represented a continuous beam (rail) resting on a continuous resilient support (resilient pad), which, in turn, rested on a second continuous beam (track foundation) supported by another continuous resilient support (soil). This analysis was used basically to determine the effect of the resilient pad on the stresses in the track structure and in the deflections and resultant pressures developed in the soil beneath the track structure.

The results of this program showed that, although the deflections in the system did not change appreciably, the bending moments in the track structure were reduced greatly when a resilient member was used.

The second computer program developed to study the effects of a resilient pad under the rail was an analog computer program used to study dynamic characteristics. The program was designed to represent the portion of a car supported by one truck together with the associated track structure. The conclusions reached from this study were that the use of a resilient member has a negligible effect on the dynamic displacements of the car body, but it has the most significant benefit in reducing the forces generated at the wheel-rail interface, which should reduce wear and deterioration of the rails, rail attachments, wheels, and other vehicle components.

#### Rails and Attachment Fittings

The third significant portion of the program was the consideration of new ideas for the rail, rail fittings, and the attachment to the supporting structure. The problem here was to devise a fastening device which would hold the rail firmly under the high loads applied, yet would provide easy and positive adjustment in both vertical and lateral directions. It was considered that once the rail was laid accurately, adjustment would only be required at time intervals on the order of 2 to 5 years, and that the adjustment would be required only as the result of gross settling or other changes in the ground beneath the track structure. Several practical appearing designs were developed for the adjustable rail fastener.

These three major technical studies are discussed individually in detail in the Technical Work section of this report.

The scope of the project eliminated consideration of nonstandard railheads; however, several ideas were conceived for rail cross sections which would minimize waste when it was necessary to replace a rail due to wear on the side or top of the railhead. One particularly intriguing design recommended uses a double-headed rail which can be turned over to get double wear life from the rail. Although similar in design to the English bull-head rail, the method of support is quite different.

SUMMARY

The essential recommendations, conclusions, and technical results of this work are summarized below:

- (1) An advanced track structure should be designed so that all of its components and the soil supporting the track structure are subjected to loads and stresses within their allowable limits, so that the only reason for the track alignment to change is due to gross settling of the earth below the track structure or excessive wear of the rail head.
- (2) The deleterious effects of high train speeds on the soil beneath the track can be minimized by supporting the rail on a continuous track structure. This track structure must be stiff enough in longitudinal bending that the soil experiences one pressure cycle per truck passage instead of one pressure cycle per wheel passage, as in conventional track.
- (3) A design criterion based on dynamic soil pressure was developed, enabling various track structures of greatly varying design to be compared in terms of hardship imposed on the soil.
- (4) The design criterion can be met by any of several continuous structures ranging from two deep narrow beams (one beneath each rail), to a continuous reinforced concrete slab built much in the manner of a highway. However, in considering the most economical method of construction, it appears that the cost decreases as the depth of the structure decreases, making the use of a relatively shallow (2-foot deep) slab or pair of beams the most attractive, costwise. Specific designs of both types are recommended.
- (5) Materials considered most appropriate for the track structure are concrete and steel. It is probable that any track structure would use both of these materials, ranging from a reinforced concrete structure composed predominantly of concrete with relatively small amounts of steel reinforcing, to an "all-steel" structure. The reinforced concrete type of structure would be cheaper than the equivalent steel structure.
- (6) In track structures that meet the design criterion based on soil pressure, stiffness, rather than bending stress, is the governing factor. However, thermal expansion stresses in a continuous concrete structure must be considered; expansion joints are not recommended in the continuous concrete members.
- (7) The effects of track structure resilience on car ride, and on stresses and deflections in cars, trucks, and track structure components were investigated in some detail. An analysis of the many effects of providing resilience between the rail and the track structure led to the conclusion that some resilience is definitely desirable, but that too much resilience is detrimental. Practical values of resilience have

the most significant benefits of reducing track structure bending moments and the dynamic forces generated at the wheel-rail interface, but have almost no effect on the displacements of the car body. Car body acceleration is affected by resilience at sinusoidal input frequencies above 10 cps.

- (8) Several nonconventional rail designs were generated, based on the objective of reducing the amount of steel which must be scrapped when the rail must be replaced because of excessive railhead wear, cracking, or spalling. The restriction of using standard railhead contour means that the railhead wear will still be a significant problem, although advances in the design of the track structure and the rail vehicle should reduce this wear. A large number of other nonconventional rail designs were also generated, and are contained in the report.
- (9) The attachment of the rail to the supporting track structure was one of the most difficult problems to solve satisfactorily. Although frequent maintenance is not envisioned, it is believed that gross settlement of the track structure due to changes in the earth will require adjustment and realignment of the track to be made at intervals of possibly 2 to 5 years. This, compared with the problem of installing rails accurately on a relatively inaccurate track structure, led to the necessity for providing lateral and vertical adjustment means in the rail attachment device. Several rail attachment devices which meet these requirements are presented in the report.

RECOMMENDED TRACK STRUCTURES

After consideration of all ideas which were conceived during this project, with strong emphasis on practicality in terms of cost, four track structures were chosen as the recommended ones for serious consideration by the Department of Commerce. Altogether, four types of foundation and four basic types of rail (one being standard rail) were identified as being promising. Many compatible combinations of these rail and foundation designs are possible in addition to the four combinations recommended. The four types of rail and foundation designs are listed below, with each listing in the order of design preference. For purposes of discussion the designs are paired together.

<u>Foundation Design</u>	<u>Rail Design</u>
(1) <u>Twin RC Beam</u> --reinforced concrete longitudinal beams	(1) Two-headed rail
(2) <u>Slab</u> --reinforced concrete slab	(2) Encapsulated rail
(3) <u>Composite</u> --composite steel and concrete longitudinal beams	(3) Standard rail
(4) <u>Twin Steel Beam</u> --steel longitudinal beams	(4) Deep rail with replaceable head

The first choice for a recommended track structure is the twin RC beam foundation, in combination with the two-headed rail. This foundation beam design was calculated to be the lowest cost structure that could meet the design criteria, and was evolved from studies of beams of many cross sections. Construction and operating problems associated with the first three structures, all utilizing substantial amounts of concrete, are believed to be fairly predictable, and the choice of one of these three is primarily an economic one. The fourth structure, however, being an all-steel structure in the earth, has more unknown factors associated with it, including corrosion and vibration problems. However, it appears to be competitive economically and, therefore, was considered.

Recommended Track Structure 1--  
Twin Reinforced Concrete Beam

As shown in Figure 1, the recommended structure consists of two longitudinal continuous reinforced concrete beams, joined at 20-foot intervals laterally by reinforced concrete cross-ties. Due to its depth, construction of this type of structure would require forms for the longitudinal beams and cross-ties, if the latter are cast-in-place. If precast cross-ties are used, they would be set in place with their ends and reinforcing rods projecting into the

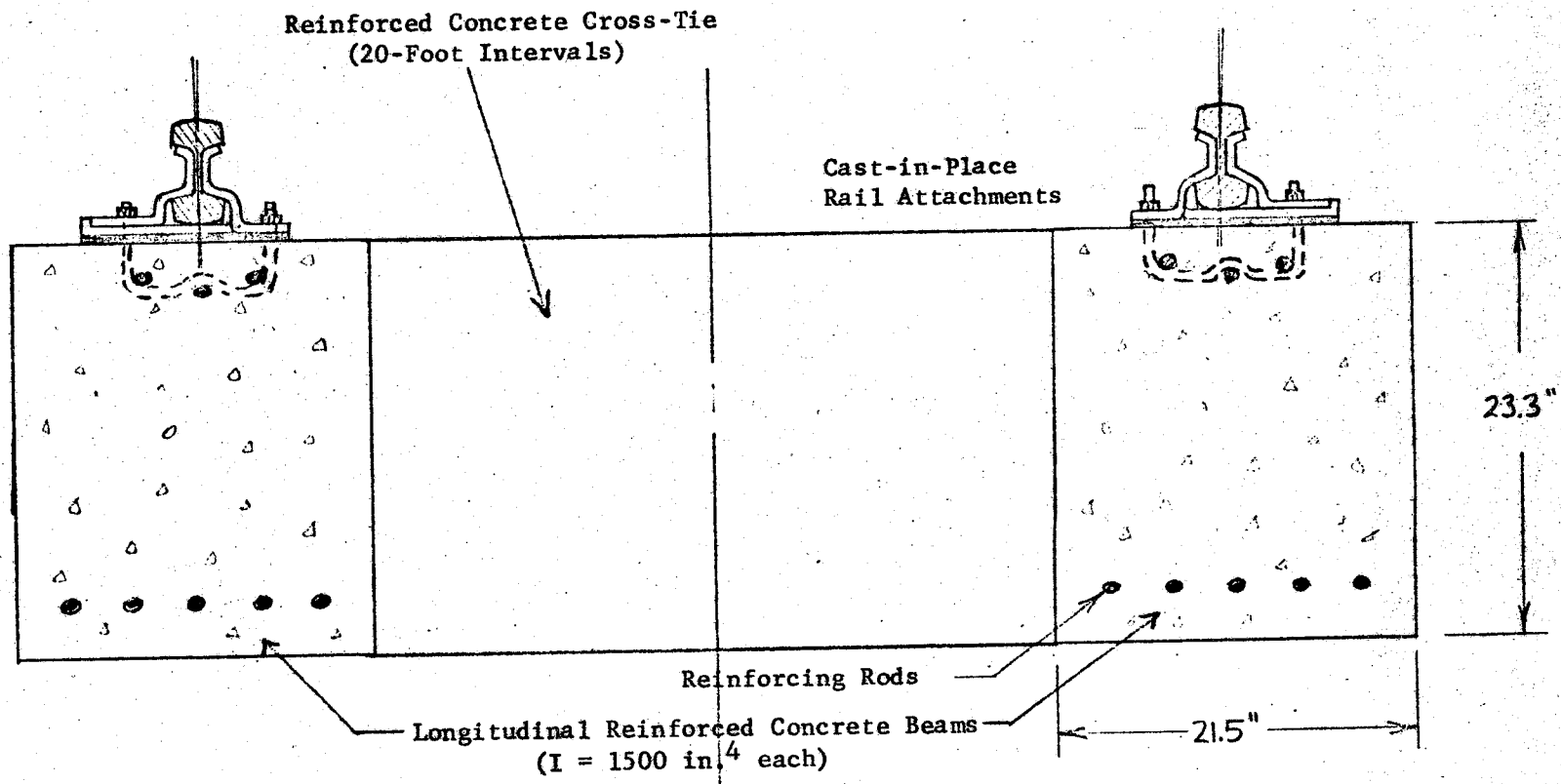

FIGURE 1. TWIN-REINFORCED CONCRETE BEAMS WITH DOUBLE-HEADED RAILS

longitudinal beam area. When the longitudinal beams were poured, the entire structure would become one unit. The cost of building this structure would be considerably less than that of the Slab, as the extra cost of concrete in the Slab costs considerably more than the extra complexity of the laterally-braced longitudinal beam construction.

The depth of the beams is dictated by the soil pressures and by economics. An analysis of various beams showed that relatively narrow and deep longitudinal beams were more expensive than the beams shown in the recommended structure, although either type of structure would meet the soil pressure criterion.

The chosen structure (see Table 2, page 66, beam structure 6) is composed of beams 21.5 inches wide and 23.3 inches deep, having a total steel reinforcing rod area of 9.94 in.<sup>2</sup>, with 6.63 in.<sup>2</sup> being at the base of the beam and the remainder at the top. Stresses under 45,000-pound static axle loads were calculated to be around 5300 psi in the steel and 300 psi compression in the concrete.

The rail shown in this structure is a two-headed rail which can be inverted to give twice the wearing surface. Because wear will occur on both faces, the rail cannot be supported by the lower railhead surface. The rail fastener concept is shown in Figure 2. Although all rail fasteners mentioned in this report will, of course, need further design analysis, one of the ideas behind this design is that the fastener could be constructed from a single rolled steel cross section which is cut into lengths, partially split, and bent to form the cross section shown. Vertical and lateral adjustment by metal shims is provided at the base of the fastener, and the same shims are used to transfer load vertically and laterally through the attachment device into the structure. A resilient pad between the rail fastener and the structure provides the desired amount of resilience and serves to provide uniform load distribution into the concrete structure. An equivalent vertical spring rate of 25,000 lb/in. per inch of rail length could be provided by 12 x 14 x 0.4-inch neoprene pads spaced at 3-foot intervals, for example.

Preliminary estimates indicate that construction costs for this structure would be \$254,000 per mile for the support structure, and \$131,000 for the two rails and attachments, giving a total initial cost of \$385,000 per single track mile. The basis of these costs is given in the following section of the report and in Appendix A. Contractor's profit and contingency are not included.

#### Recommended Track Structure 2-- Reinforced Concrete Slab

The simplest in concept, though not the cheapest, track structure devised which will meet all of the design criteria is shown in Figure 3. It consists basically of a deep reinforced concrete slab having two grooves into which the rails are accurately placed and then encapsulated. Note that all



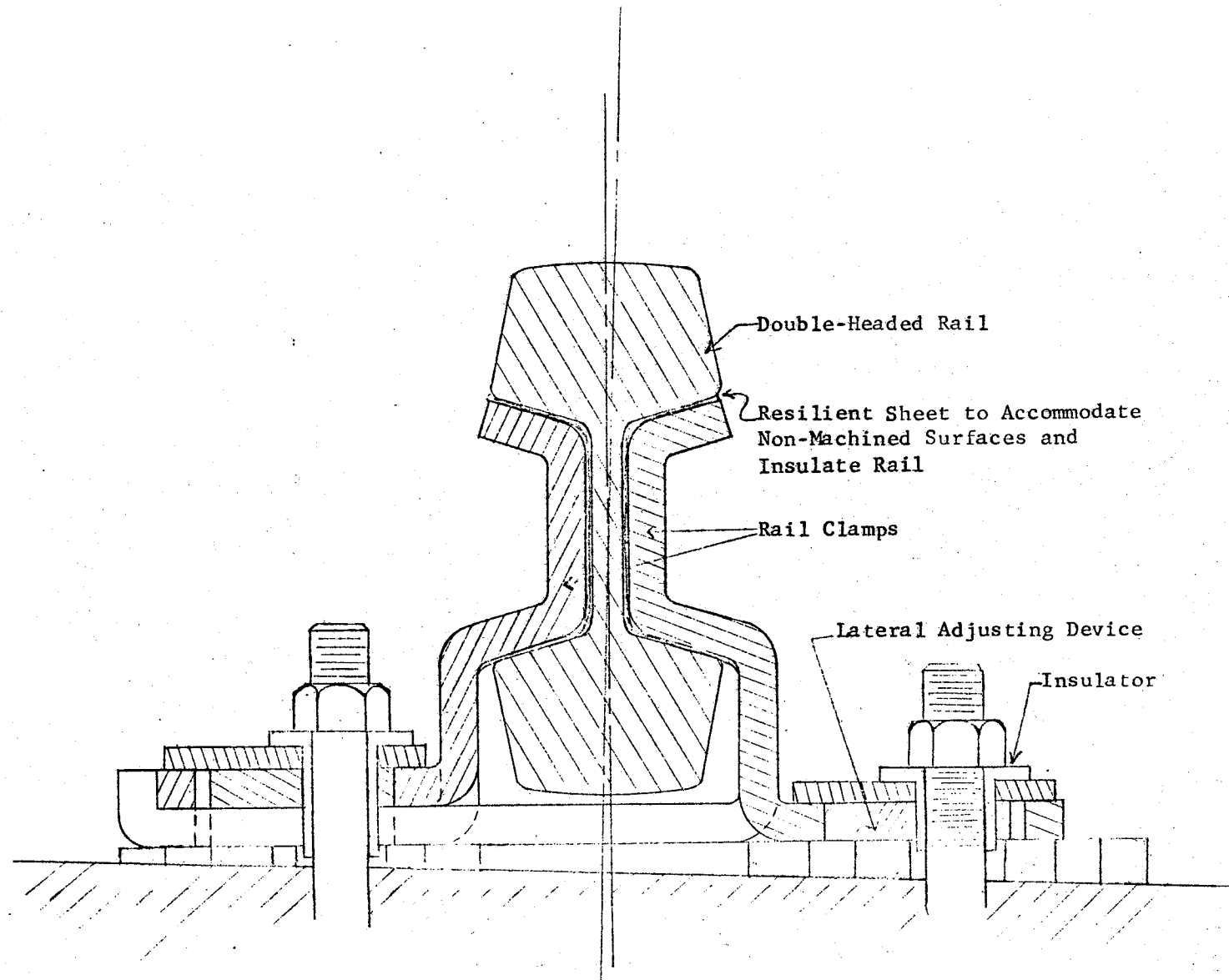
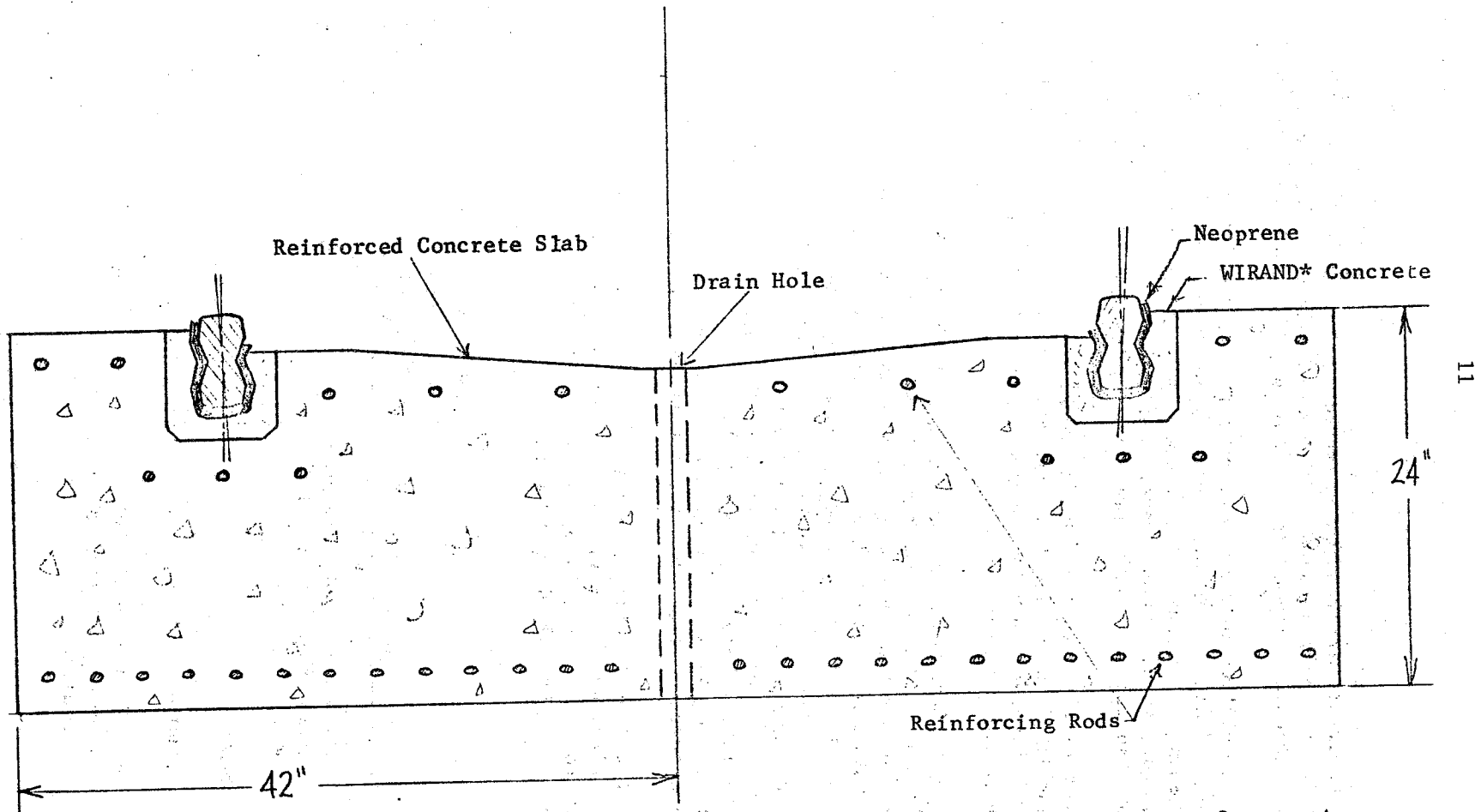

FIGURE 2. TWO-HEADED RAIL AND FASTENER



\*Trademark of the Battelle Development Corporation

FIGURE 3. REINFORCED-CONCRETE SLAB TRACK STRUCTURE USING NEOPRENE-ENCAPSULATED RAIL

attachment hardware is eliminated, resulting in the simplest imaginable overall design. This is the only structure shown which has continuous rail support, although this method of support can, of course, be used with other foundations.

The quantities of steel and concrete in the slab are just twice those of the twin-beam design. A reduction in the depth of the slab would violate the design requirement of transmitting to the soil only one pressure pulse per truck passage. However, for the same loads, soil pressures are only half those for the twin-beam structures, so this structure should be the most stable one shown.

The area of steel used in the reinforcing rods is 19.9 in.<sup>2</sup>, with 13.27 in.<sup>2</sup> near the bottom, and the rest near the top of the slab. Maximum stresses under 45,000-pound axle loads are 2700 psi in the steel and 163 psi (compression) in the concrete.

An objectionable aspect of the design which goes with the continuous support is the difficulty of adjusting the rail. It is assumed that the only adjustment needed would be due to gross settling of the earth, so that this would not need to be done more often than every several years. However, when adjustment or rail replacement is required, it would be necessary to melt or destroy the material surrounding the rail, or to remove the rail and surrounding material from the groove and replace it. The structure would be designed so that the shear strength of the material relative to the foundation would only be sufficient to withstand operating loads imposed on the track. This would make it relatively easy to insert a wedge-shaped ram at some starting point and proceed down the track peeling material out of the groove with the ram.

To determine the practicality of this means of rail mounting, cost estimates of various materials which might be used to contain the rail were made. It was quickly found that the amount of material other than concrete should be minimized, based on the following numbers:

<u>Material</u>	<u>Cost per Square Inch of Cross Section per Foot of Rail, Installed</u>
Cheapest suitable meltable metal (lead with 7 percent antimony)	\$0.68
Steel	0.85
Neoprene	1.20
WIRAND* concrete (for tension and compression strength)	0.08

---

\*Trademark of the Battelle Development Corporation.

It was concluded that the most economical way to mount the rail would be to wrap it partially with a 1/4 or 3/8-inch-thick resilient sheet, such as neoprene, and then to grout it in place in the groove with WIRAND concrete. The size of the groove should be minimized, with the specified adjustment tolerance being the limiting factor. Costs shown in the above tabulation are based on a neoprene cross-sectional area of 5.2 in.<sup>2</sup> per rail, and a WIRAND concrete grout area of 35.3 in.<sup>2</sup> per rail. The neoprene sheet would be designed with a shape factor chosen to obtain the desired resilience. A design such as this is shown in Figure 4.

The two-headed rail design shown in Figure 4 can be inverted and placed back into service. Virtually any rail cross section could be used, however.

The feasibility of this rail attachment design depends in large part on the techniques worked out for encapsulating the rail in place accurately and removing or adjusting it, with particular emphasis on minimizing the material cost. From the standpoint of sheer simplicity it would be hard to beat this system. Also, the continuous support offered the rail in this structure is ideal. The slab would, however, be suitable with other types of rail attachments.

Construction costs for this structure were estimated to be \$300,000 per mile for the support structure and \$149,000 for the double-headed rail and its attachment, giving a total of \$449,000/mile of single track.

#### Recommended Track Structure 3-- Twin-Composite Beam

The third track structure, shown in Figure 5, consists of a composite (concrete and steel) longitudinal beam structure for the foundation, plus conventional rail. In this type of foundation structure, the steel in the beam provides much of the strength, while the concrete adds compressive strength, provides corrosion resistance to the steel, and provides a good bearing interface with the earth when it is poured in place. The specific structure shown utilizes a 16 WF 78 beam for stiffness and strength.

Conventional rail is shown, as it is anticipated that this will be desired in many applications. However, the rail attachment device shown in Figure 6 allows for vertical and lateral adjustment of the rail relative to the continuous steel beams. The type of fastening device shown here is considered to be the cheapest one which provides adequate support to the rail.

The cost of this structure should be very close to that of the twin RC beam structure, depending on the relative cost of steel (welded) beams or reinforcing rod. Taking into account the welding problem and the fact that the steel in the web of the beam contributes little to the bending stiffness, it was assumed that this structure would cost at least as much as the RC beam structure. Calculations showed the cost to be about \$308,500 per track mile. The cost of the rail and its attachment is estimated to be \$153,600, giving a total initial cost of at least \$462,100/mile. Since standard rail is used, maintenance costs will be more than those associated with the double-headed rail.

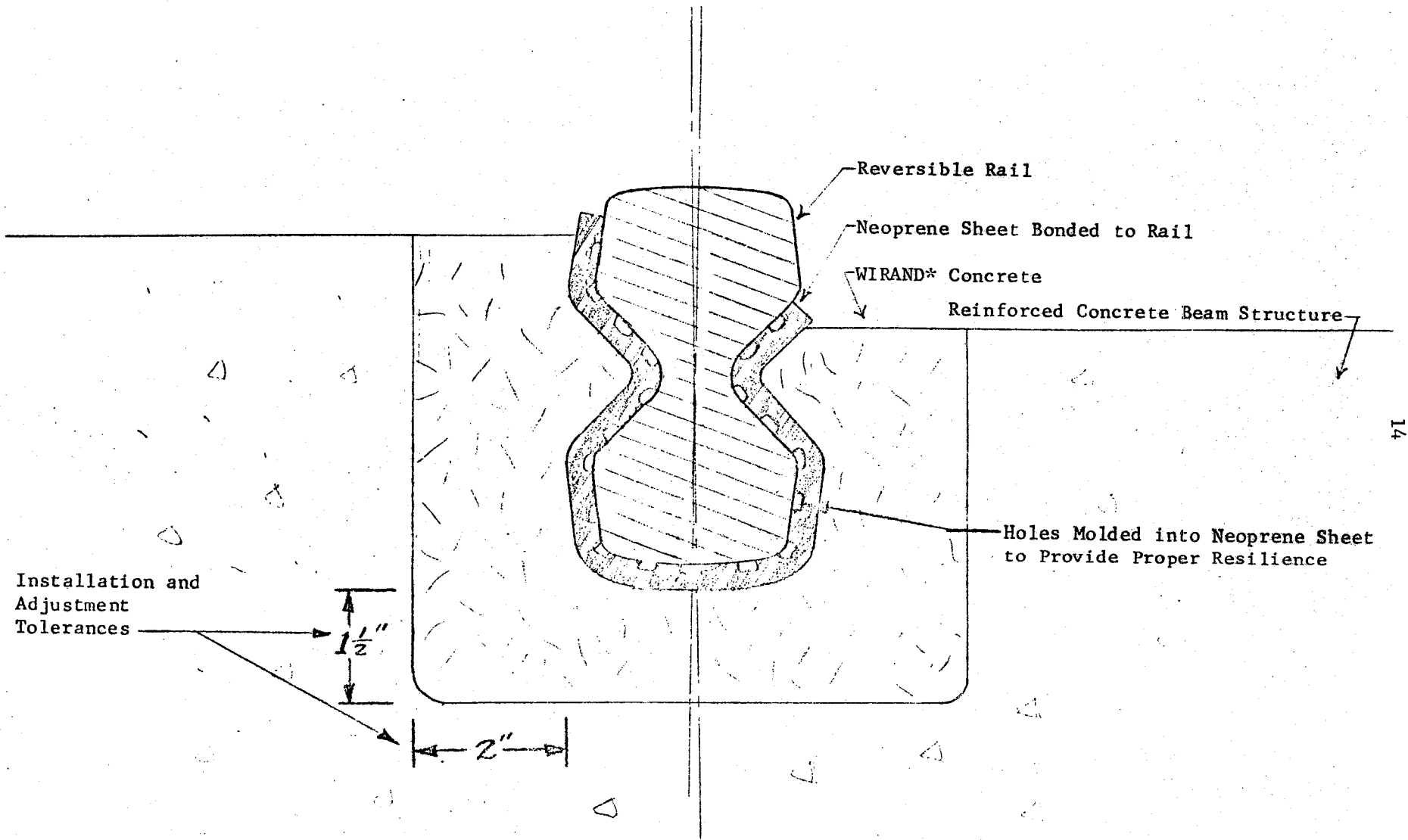

\*Trademark of the Battelle Development Corporation

FIGURE 4. ENCAPSULATED RAIL DESIGN FEATURING REVERSIBLE RAIL MOUNTED RESILIENTLY IN CONCRETE

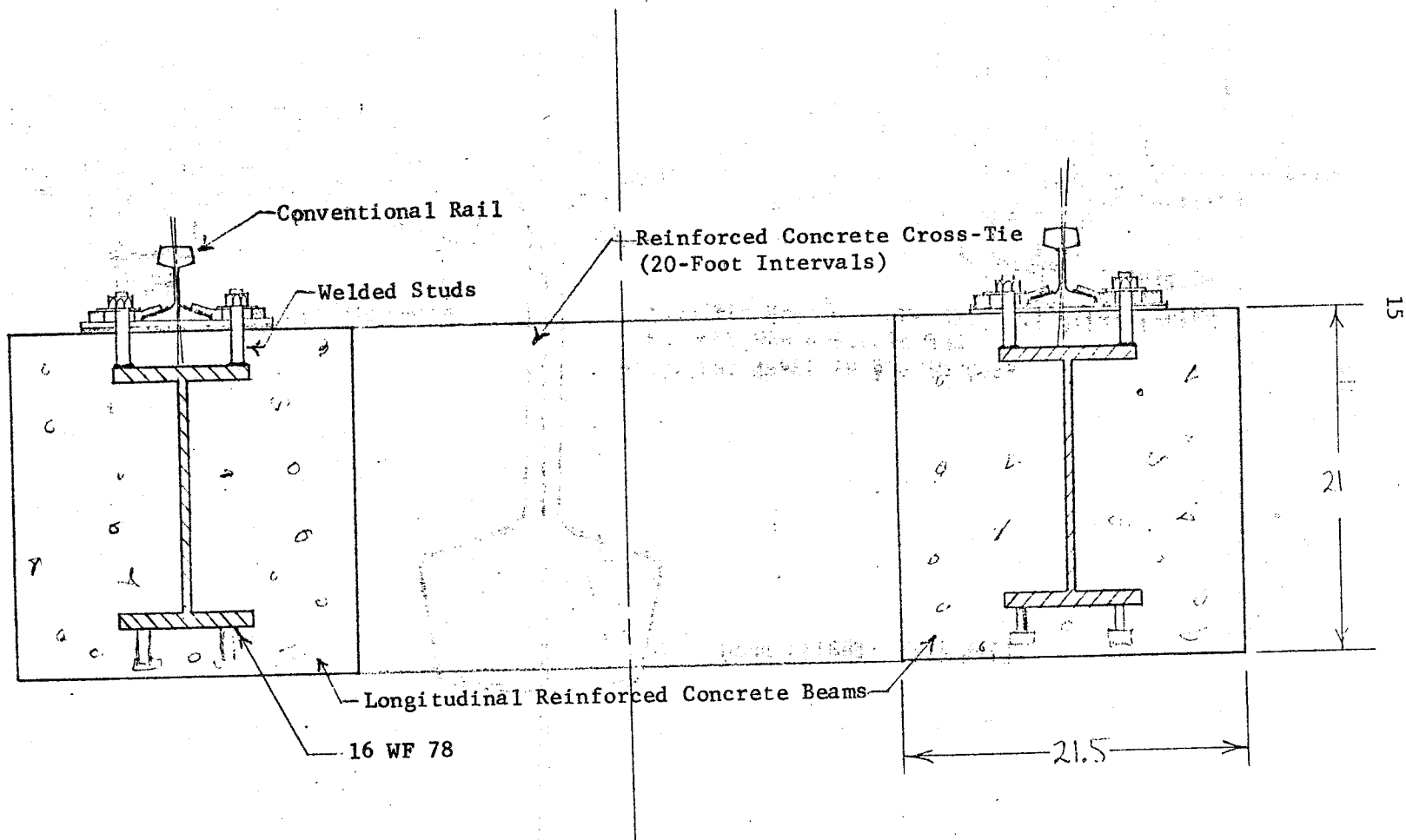

FIGURE 5. COMPOSITE TRACK STRUCTURE USING TWIN STEEL-CONCRETE BEAMS WITH WELDED STUDS FOR SHEAR CONNECTORS AND RAIL ATTACHMENT

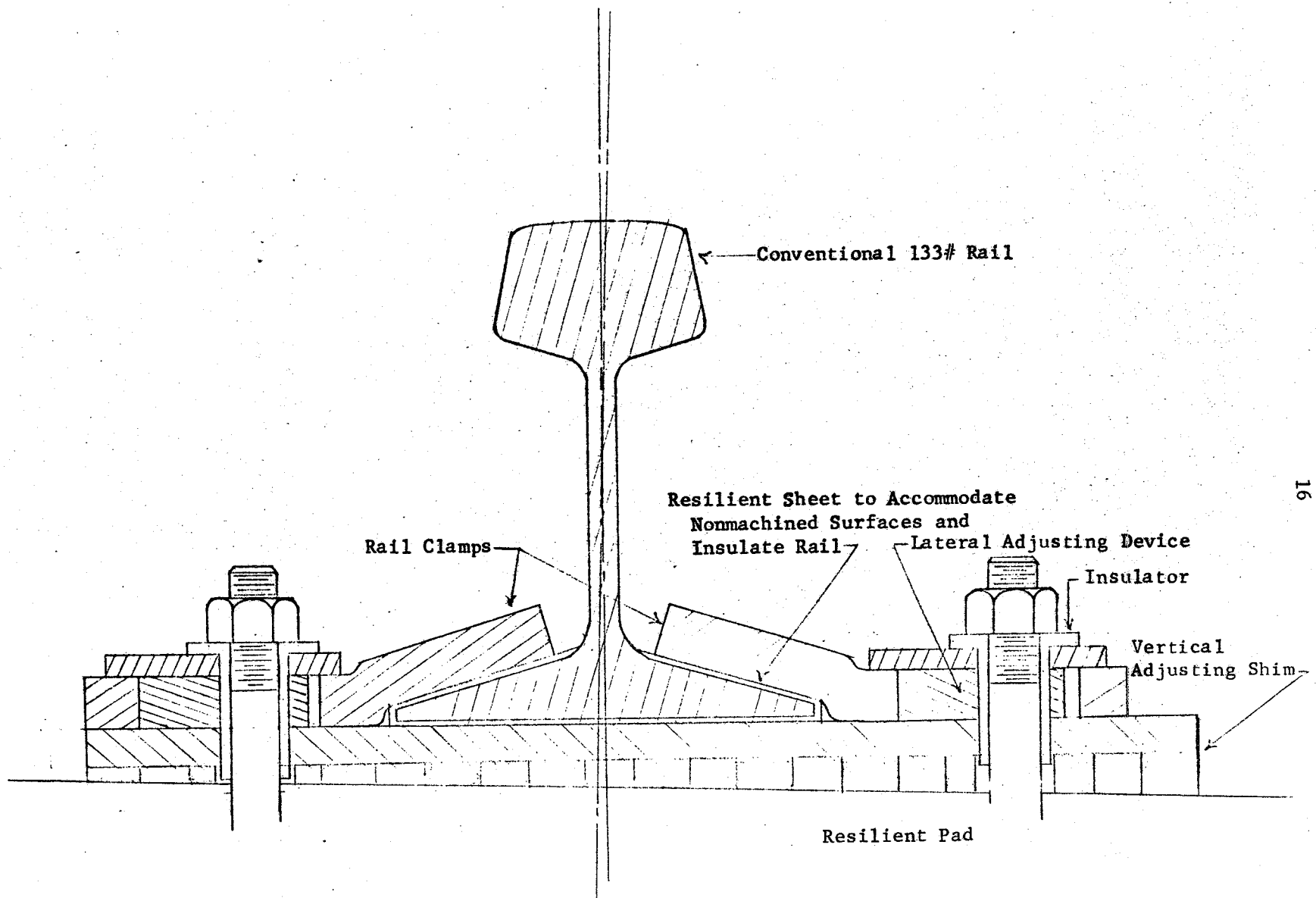

FIGURE 6. ATTACHMENT DEVICE FOR STANDARD RAIL

Recommended Track Structure 4--  
Twin Steel Beam

The fourth type of track structure is shown in Figure 7. For some locations--for example, on bridges or elevated sections of the roadbed, it may be desirable to use an all-steel beam construction. However, the steel beams shown in this track structure were chosen on the basis of providing the same support as the concrete structures shown when supported continuously by the soil, so that all four recommended structures are comparable structurally.

Some of the problems associated with a steel structure in the soil can be compared to those of a pipeline. Corrosion protection, both by wrapping (or coating) and by cathodic beds would probably be necessary. Other problems, including vibration and electrical isolation, would be more severe than for the concrete structures.

Each of the "rails" shown in Figure 8 consist of an assembly of two stiff steel beams and a replaceable railhead. Use of the small cross section in the replaceable railhead (to minimize replacement costs) dictates that these two rail beams be continuous to give bending support to the railhead. By making this three-piece rail stiffer than conventional rail, the attachment point spacing can be increased.

Two foundation beams are shown in Figure 7. The smaller beam is not as stiff as the larger beam because it is used with a three-piece rail that is stiffer than conventional rail. The larger foundation beam has a stiffness equal to the twin-beam concrete design, and was sized to obtain a valid cost comparison between equivalent all-steel and concrete beams.

If a significant percent of the stiffness required by the entire track structure is provided in the three-piece rail, the foundation beam can be reduced in size accordingly, depending on what degree the two act as one, which depends on the shear connection between them. To size the structures shown, no shear connection was assumed, even though some would be provided by the rail attachment devices.

The same type of rail adjustment and support as shown in the previous structures is also applicable to this design, the difference being that the steel railhead-beam assembly rather than the rail itself is adjusted and held, and the adjustments can be made individually at each side of the rail.

The cost of a one-piece all-steel foundation beam structure of the same stiffness as the twin RC beam structure, as shown in Figure 7, was calculated to be between \$266,500 and \$306,700 per single track mile, depending on fabrication costs. Costwise, therefore, this support beam appears to be competitive with the concrete slab construction. Costs were calculated to be \$168,200 to \$207,400 for the three-piece replaceable head rail shown in Figure 8 giving a total of \$434,700 to \$514,100 per single track mile for the total track structure. Maintenance costs for rail replacement should be minimum, however.



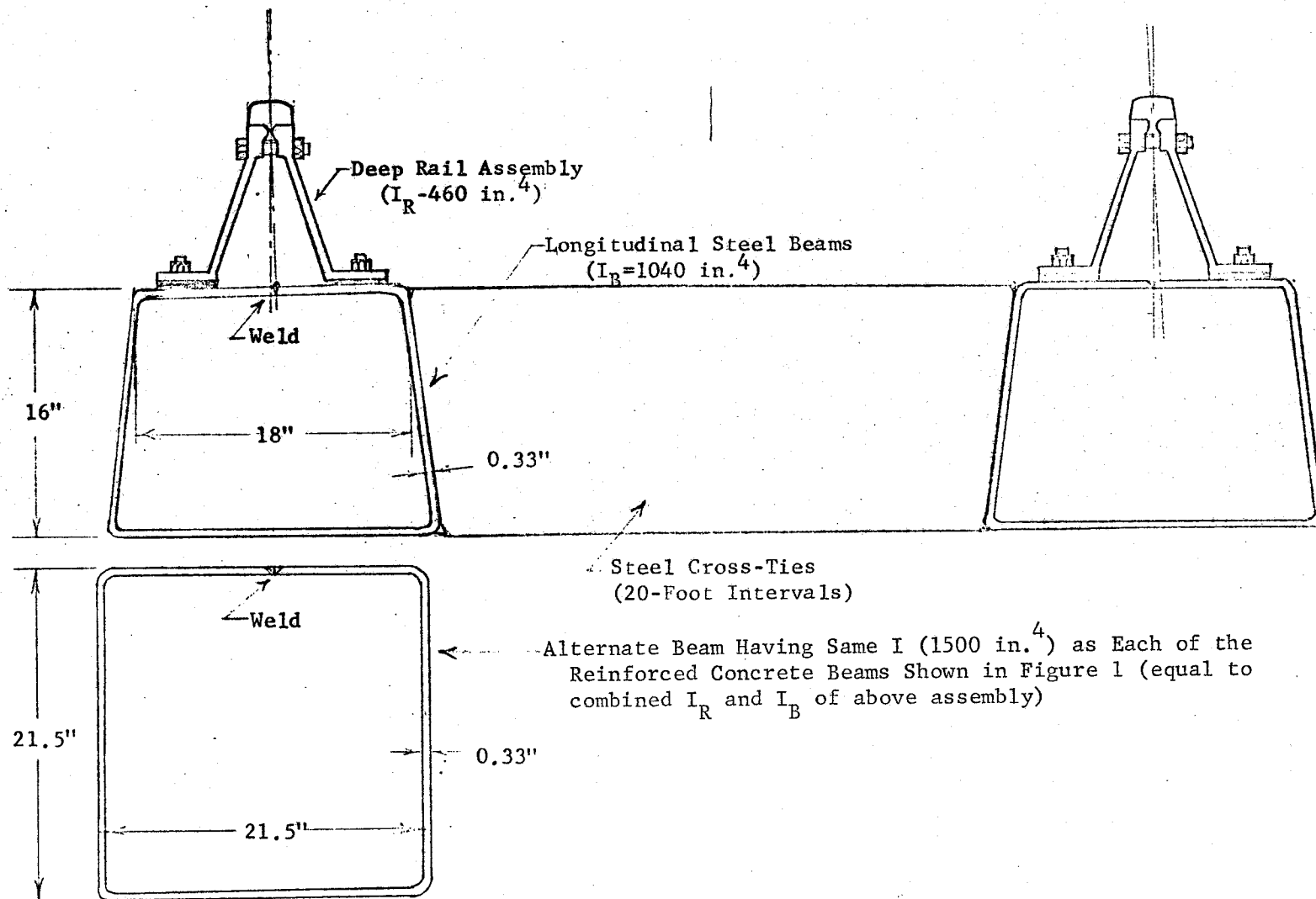

FIGURE 7. TWIN STEEL BEAM TRACK STRUCTURE SHOWN WITH SPECIAL REPLACEABLE-HEAD RAIL

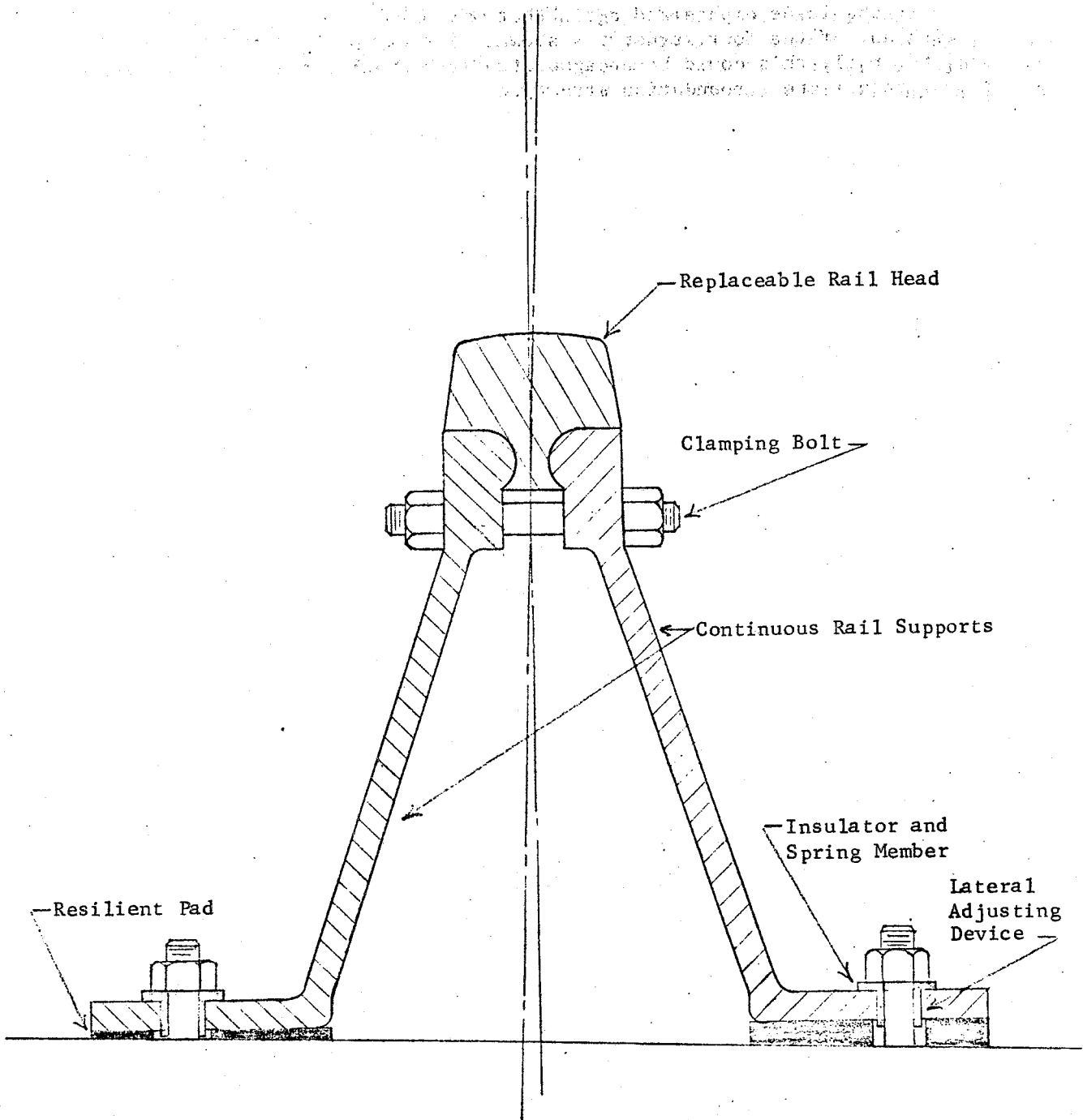

FIGURE 8. REPLACEABLE-HEAD RAIL DESIGN

It should be emphasized again that any of the four rail designs shown can go with any of the four structures shown. For example, in the case of the encapsulated rail, this could be encapsulated in a steel channel member forming the top of an all-steel foundation structure.

## DISCUSSION OF TRACK STRUCTURES

A discussion of some of the general characteristics of the recommended track structures follows, including discussion of cost, adaptability to variable roadway conditions, electrical characteristics, alignment considerations, and drainage.

### Initial Construction Costs

A summary of the initial costs of construction for the four recommended track structures is shown in Table 1. Some of the factors which affect these costs are given in the discussion following the table, and a more detailed cost breakdown is continued in Appendix A.

There are many factors which affect the cost of any of the recommended track structures, and it is impossible to accurately predict the installed costs until these factors are known. For example, one of the significant factors in determining the cost of such a structure will be its location. The costs of both concrete and steel depend on the proximity of the structure to a source of concrete and steel.

The cost estimates given are, therefore, only intended to show some of the relative costs which might be associated with the various track structures and are not to be used as the basis for estimating the installed costs. Certain cost items will be the same for any of the track structures as, for example, the cost of excavating.

It has been assumed that all the structures will be placed on existing roadbeds where the level of the track has already been established, and that the new track would be at the same level as the existing track. Costs for the foundation, whether concrete, steel and concrete, or all steel, are based on providing a track structure with attachment devices projecting from the top of the structure to form the interface with the rail fastener device.

It is believed that the costs associated with the concrete structures are more accurate than those for the steel structures, since in the latter the cost of installation of the steel beam is difficult to estimate accurately. The second portion of the costs covers the rail and associated rail attachment devices. As mentioned previously, any of the rail attachment devices can be used with any of the supporting structures, so the cost for each have been calculated independently.

It was assumed that the first step in the construction of any of the four track structures shown would be to remove the existing track(s) and excavate a trench roughly 2-1/2 feet deep by 8 feet wide (per track). Bank gravel or similar material would then be poured into the trench and leveled to an approximate depth of 3 inches.

TABLE 1. ESTIMATED COSTS FOR INSTALLED TRACK  
STRUCTURES PER SINGLE TRACK MILE

		\$/Single Track Mile
<b>(1) Twin RC beam with double-headed rail</b>		
Foundation		254,000
Rail and attachment		131,000
	<b>Total</b>	<b>385,000</b>
<b>(2) Slab with encapsulated rail</b>		
Foundation		300,000
Rail and attachment		149,000
	<b>Total</b>	<b>449,000</b>
<b>(3) Composite beam with conventional rail</b>		
Foundation		308,500
Rail and attachment		153,600
	<b>Total</b>	<b>462,100</b>
<b>(4) Twin steel beams with deep steel rail contributing part of the bending moment</b>		
Foundation beams (I = 1040)		266,500-306,700*
Rail and attachment (I = 460)		168,200-207,400*
	<b>Total</b>	<b>434,700-514,100</b>

\*For steel costs of \$.20 to \$.25 per pound fabricated and installed.

For the concrete structures, the next step would be to install forms in the trench (depending on the type of excavation), after which the reinforcing bars would be lowered in an assembled condition into the forms. The attachment devices for the rail-fastening devices would be held in position by the forms so that after the poured concrete had hardened the rail could be fastened to it. For the reinforced concrete structure consisting of two longitudinal beams and cross ties, it was estimated that the cheapest way to build this would be to form the entire structure and cast it in place. This structure would require considerably more forming than the slab structure, which would need only the outside forms. However, this is more than compensated for in the additional reinforced concrete required for the slab structure, although a compromise structure between these two is envisioned in which a mound of dirt would be placed in the center of the trench before pouring, thereby reducing the amount of concrete used in the slab.

For the composite structure, the method of construction would be similar, except that the steel-reinforcing beams would be held in position in the trenches while the concrete was poured. These beams would probably be welded together out of the trench at a considerable distance ahead of where the concrete was being poured. This would be done to simplify the welding procedure, as it would be very difficult to weld the beams together in the trench, particularly the bottom weld.

For the all-steel structure, the beams would again be welded together above the trench and then lowered into the trench and held in position while a 2-inch layer of grout was pumped in under them. It is very difficult to estimate the costs for this type of installation, and this would depend on the techniques which would be worked out.

A more detailed breakdown of these costs is contained in Appendix A. The only maintenance anticipated is realignment of the rail due to gross settlement of the structure and replacement of the railhead due to excessive wear or other deterioration. The frequency intervals at which either of these maintenance operations is required will not be known until actual track structures are built and tested.

#### Adaptability to Variable Roadway Conditions

As stated in the request for proposal, one criterion against which advanced track structures will be evaluated is their adaptability to variable roadway conditions.

It is believed that the significant conditions which will vary will include:

- (1) Elevation and curvature
- (2) Soil or subgrade

(3) Weather

(4) Presence of crossings, turnouts, switches, etc.

The first two variables can be treated together, as an elevated structure can be thought of as a case in which the soil support is zero. The opposite extreme is where the track structure will be built on bedrock. At either of these extremes, the use of the soil pressure design criterion is not valid, and other design parameters must be used. In the case of an elevated structure, deflections or stresses or deformations in the structure will replace soil pressure as the design criterion. On the other hand, when the track structure is built on bedrock, the track structure will need a minimum of rigidity since this will be provided by the rock. Between these extremes, however, the use of the design criterion based on soil pressures enables the track structure to be designed for any soil condition by the use of the proper value of  $k_0$  (modulus of soil or subgrade) in the equations. As long as ballast or other subgrade material is used to support the structure, the design criterion is applicable, even though the track may be above or below grade.

No particular distinction between curved and/or elevated track was made in the development of the design criterion, but it would seem that the only modification necessary would be to compensate for the difference in wheel loading between inside and outside tracks on curves, if different wheel loadings occur consistently. Specific drainage details for the track structure would, of course, depend on the superelevation.

With regard to the variable roadway conditions caused by the weather, this is in large part compensated for by proper attention to drainage beneath the track structure such that controlled moisture conditions can be achieved. This will stabilize the structure from the standpoint of soil changes due to rain, frost heaving, etc. Since the heads of the rails will be standard, no new problems are introduced with regard to ice or snow on the rails. Here again, proper drainage for surface water would be included in the track structures to insure that water is not trapped on top of the concrete between the rails. All materials used in the attachment devices would need to be designed to withstand normal weather conditions.

No particular attention has been devoted to problems involved with items such as turnouts, switches, etc. However, no particular problems are envisioned as a result of utilizing any of the track structures recommended. Short sections of track using conventional switches would, of course, be installed if necessary.

In summary, then, the use of the design criterion enables track structures to be designed for a wide range of soil properties. Where the track structure is to be elevated or built on bedrock, the design criterion should not be used. A minimum structure would be needed in the case of bedrock. For elevated structures, allowable stresses and deflections will be the governing factor. These will depend on the specific design of, for example, bridges used. Some of the alignment tolerances which would become important factors in the design of elevated structures are discussed below.

Track Alignment Standards

The Track Alignment Standards listed below were taken from an earlier Request for Proposal (1)\* issued by the Department of Commerce, and as such they provide some idea of the desired track alignment.

"The following track alignment standards have been established for the demonstration route:

- (a) Maximum deviation from a true profile to be 3/8 inch (for 100 mph) and 1/4 inch (for 125 mph and above) in 21.3 feet. True profile to be a straight line connecting the high points on the plotted profile.
- (b) Maximum warped surface to be that represented by a change of cross level of 1/2 inch (for 100 mph) and 3/8 inch (for 125 mph and above) at any two points less than 62 feet apart; but not to exceed 1/4 inch in 19.5 feet.
- (c) Actual cross level not to vary more than 1/2 inch (for 100 mph) and 3/8 inch (for 125 mph and above) from level on tangents, or from designated superelevation on curves.
- (d) Maximum deviation in alignment not to exceed the following middle ordinates to chords:
  - Tangents:  $\pm 1/2$  inch (for 100 or 125 mph and above), 85-foot chord
  - Curves up to 0 degree 45 feet:  $\pm 1/2$  inch from designated ordinate (for 125 mph and above), 85-foot chord
  - Curves up to 1 degree 20 feet:  $\pm 1/2$  inch from designated ordinate (for 100 mph), 62-foot chord
  - Curves sharper than 1 degree 20 feet:  $\pm 3/4$  inch from designated ordinate (for allowable speed, which will be less than 100 mph), 62-foot chord.
- (e) Maximum deviation in gauge not to exceed  $\pm 1/4$  inch on tangents,  $+1/2$ ,  $-1/8$  on curves."

While there are several ways to interpret these standards, a logical way is to assume that these standards represent changes in profile which the wheels can experience at the designated speeds. As such, they represent the sum of installation tolerance plus changes in dynamic deflections due to changes in the track structure characteristics. For example, considering the vertical deflections, this means that a "soft" track structure with, say, 1/2 inch of static deflection under each wheel could be tolerated, as long as the spring rate was uniform. In this case the profile experienced by the train would be uniform, and each wheel would deflect the track 1/2 inch. However, this same 1/2 inch could not be tolerated if it was due to change in track stiffness from one point to the next, as this would result in a dynamic profile error.

\* References are listed at the end of the report.



With these thoughts in mind, the track structures based on the soil pressure design criterion were examined in light of the track alignment standards. Basically, the design criterion dictates the rigidity ( $EI$  value) of the foundation beams as a function of the values of  $k_o$  for various types of soil. In view of the spread of the  $k_o$  value, which commonly falls between 50 to 500 psi for typical soils, the dynamic profile errors due to changes in the subgrade beneath the track structure were investigated.

Figure 9 is a plot of deflection versus soil stiffness for a rail foundation having a width of 2 feet and the lowest  $I_s$  value which satisfies the design criterion. It is seen that for the 2-foot-wide foundation the peak deflection is only 1/8 inch for the weakest soil. If the train were to travel from the strongest soil ( $k_o = 500 \text{ lb/in.}^3$ ) onto the weakest ( $k_o = 50 \text{ lb/in.}^3$ ) and then back onto the strongest in a distance of 21.3 feet (which would take 0.09 second at 160 mph) it would experience a change in deflection over the weak spot of 0.120 inch, assuming no impact factor on wheel load. This is the worst case for the soil short of a washout. If the soil were actually washed out completely for a length of 21.3 feet, then as a worst case the track structure could be considered as approaching a pinned-end beam. The maximum deflection in this case was calculated to be 0.250 inch.

In view of these results for extreme cases and the fact that a 1/4-inch deviation in 21.3 feet is allowed, it appears that installation tolerances can use up a large percentage of the allowable track profile error for most soil conditions. Calculations on change in gage due to dynamic deflections also led to the same conclusion: assuming conservative conditions and 20-foot cross-tie spacing, lateral deflections of the track structure due to lateral wheel loads caused less than 0.2 inch spread in gage on a curve, leaving the remainder of the 5/8-inch allowable range to be used up by installation tolerances.

#### Track Installation Tolerances

Ideally it is desired to be able to install the rails with no deviation from line, profile, or gage, but some error will have to be accepted in order not to require excessive installation effort. After installation of the support structure, the amount of error will be compensated for by adjusting the rail with the rail attachment devices.

Some idea of how gross an adjustment would be necessary was obtained by considering the installation of "Track Structure Design 3-C" shown in attached Drawing 0001. This structure consists of a standard 14 WF 127 beam mounted on a 6-inch-thick poured-in-place concrete footer.

The worst beams that can be bought from the rolling mill can have their top surface out of parallel with the bottom surface a maximum of 1.2 degrees. If AREA 133-pound rails are mounted flush on the top surface and the bottom surface of the WF is always level in the concrete, this 1.2-degree possible tilt can cause the gage to vary a maximum of 0.296 inch, and the rail height a maximum of 0.098 inch. The same beams can be bent both horizontally and

Track Alignment Standards

The Track Alignment Standards listed below were taken from an earlier Request for Proposal (1)\* issued by the Department of Commerce, and as such they provide some idea of the desired track alignment.

"The following track alignment standards have been established for the demonstration route:

- (a) Maximum deviation from a true profile to be 3/8 inch (for 100 mph) and 1/4 inch (for 125 mph and above) in 21.3 feet. True profile to be a straight line connecting the high points on the plotted profile.
- (b) Maximum warped surface to be that represented by a change of cross level of 1/2 inch (for 100 mph) and 3/8 inch (for 125 mph and above) at any two points less than 62 feet apart; but not to exceed 1/4 inch in 19.5 feet.
- (c) Actual cross level not to vary more than 1/2 inch (for 100 mph) and 3/8 inch (for 125 mph and above) from level on tangents, or from designated superelevation on curves.
- (d) Maximum deviation in alignment not to exceed the following middle ordinates to chords:
  - Tangents:  $\pm 1/2$  inch (for 100 or 125 mph and above), 85-foot chord
  - Curves up to 0 degree 45 feet:  $\pm 1/2$  inch from designated ordinate (for 125 mph and above), 85-foot chord
  - Curves up to 1 degree 20 feet:  $\pm 1/2$  inch from designated ordinate (for 100 mph), 62-foot chord
  - Curves sharper than 1 degree 20 feet:  $\pm 3/4$  inch from designated ordinate (for allowable speed, which will be less than 100 mph), 62-foot chord.
- (e) Maximum deviation in gauge not to exceed  $\pm 1/4$  inch on tangents,  $+1/2$ ,  $-1/8$  on curves."

While there are several ways to interpret these standards, a logical way is to assume that these standards represent changes in profile which the wheels can experience at the designated speeds. As such, they represent the sum of installation tolerance plus changes in dynamic deflections due to changes in the track structure characteristics. For example, considering the vertical deflections, this means that a "soft" track structure with, say, 1/2 inch of static deflection under each wheel could be tolerated, as long as the spring rate was uniform. In this case the profile experienced by the train would be uniform, and each wheel would deflect the track 1/2 inch. However, this same 1/2 inch could not be tolerated if it was due to change in track stiffness from one point to the next, as this would result in a dynamic profile error.

\* References are listed at the end of the report.

With these thoughts in mind, the track structures based on the soil pressure design criterion were examined in light of the track alignment standards. Basically, the design criterion dictates the rigidity ( $EI$  value) of the foundation beams as a function of the values of  $k_o$  for various types of soil. In view of the spread of the  $k_o$  value, which commonly falls between 50 to 500 psi for typical soils, the dynamic profile errors due to changes in the subgrade beneath the track structure were investigated.

Figure 9 is a plot of deflection versus soil stiffness for a rail foundation having a width of 2 feet and the lowest  $I_g$  value which satisfies the design criterion. It is seen that for the 2-foot-wide foundation the peak deflection is only 1/8 inch for the weakest soil. If the train were to travel from the strongest soil ( $k_o = 500 \text{ lb/in.}^3$ ) onto the weakest ( $k_o = 50 \text{ lb/in.}^3$ ) and then back onto the strongest in a distance of 21.3 feet (which would take 0.09 second at 160 mph) it would experience a change in deflection over the weak spot of 0.120 inch, assuming no impact factor on wheel load. This is the worst case for the soil short of a washout. If the soil were actually washed out completely for a length of 21.3 feet, then as a worst case the track structure could be considered as approaching a pinned-end beam. The maximum deflection in this case was calculated to be 0.250 inch.

In view of these results for extreme cases and the fact that a 1/4-inch deviation in 21.3 feet is allowed, it appears that installation tolerances can use up a large percentage of the allowable track profile error for most soil conditions. Calculations on change in gage due to dynamic deflections also led to the same conclusion: assuming conservative conditions and 20-foot cross-tie spacing, lateral deflections of the track structure due to lateral wheel loads caused less than 0.2 inch spread in gage on a curve, leaving the remainder of the 5/8-inch allowable range to be used up by installation tolerances.

#### Track Installation Tolerances

Ideally it is desired to be able to install the rails with no deviation from line, profile, or gage, but some error will have to be accepted in order not to require excessive installation effort. After installation of the support structure, the amount of error will be compensated for by adjusting the rail with the rail attachment devices.

Some idea of how gross an adjustment would be necessary was obtained by considering the installation of "Track Structure Design 3-C" shown in attached Drawing 0001. This structure consists of a standard 14 WF 127 beam mounted on a 6-inch-thick poured-in-place concrete footer.

The worst beams that can be bought from the rolling mill can have their top surface out of parallel with the bottom surface a maximum of 1.2 degrees. If AREA 133-pound rails are mounted flush on the top surface and the bottom surface of the WF is always level in the concrete, this 1.2-degree possible tilt can cause the gage to vary a maximum of 0.296 inch, and the rail height a maximum of 0.098 inch. The same beams can be bent both horizontally and

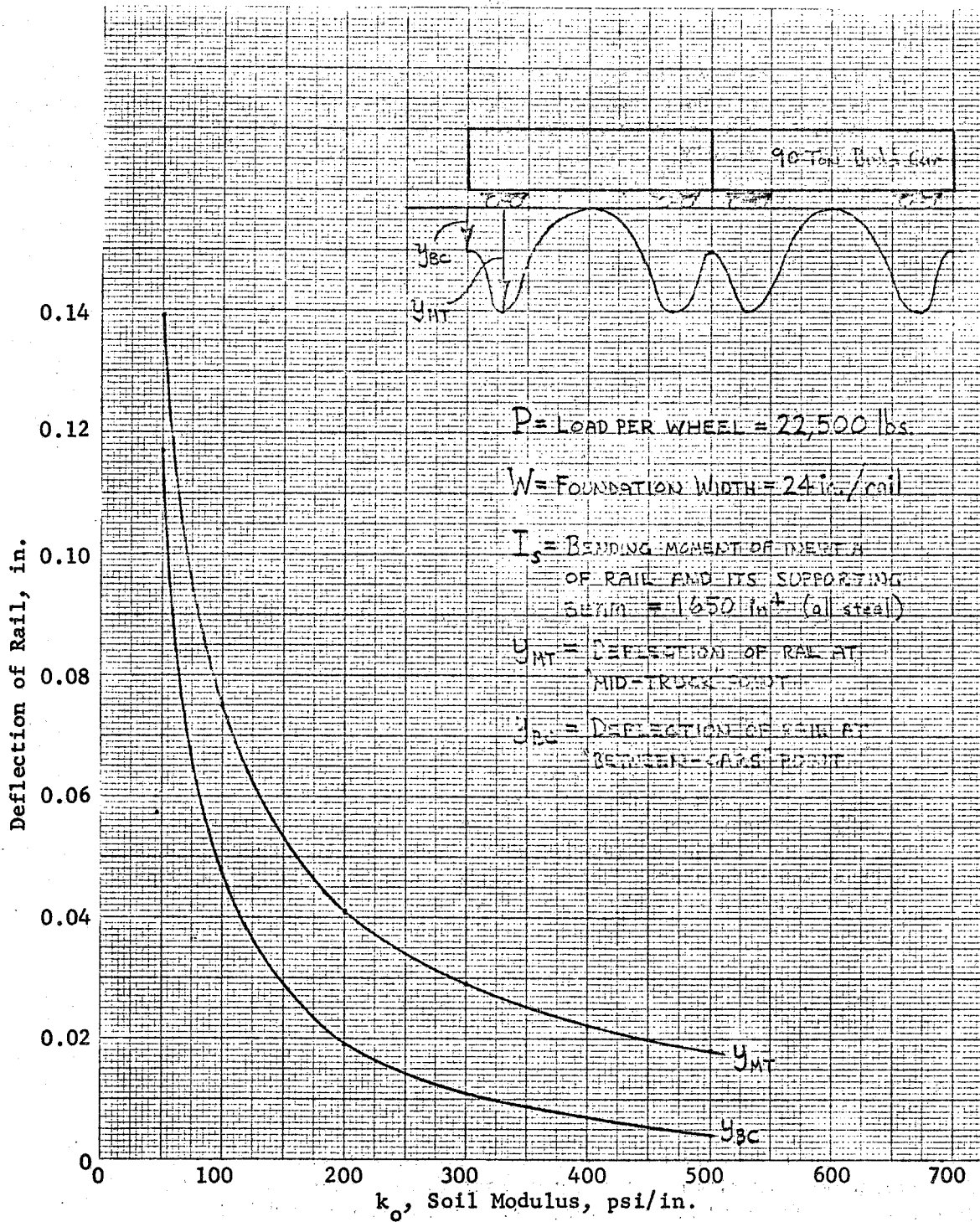

FIGURE 9. PLOT OF STRUCTURE DEFLECTION VERSUS SOIL MODULUS

vertically an amount increasing with their length. For lengths of 30 to 45 feet the maximum deviation from a straight chord is 0.375 inch, both vertically and horizontally. The worst imaginable case is for these beams to be laid, with the rail fastened rigidly to them to the same curvature, in the configuration shown in Figure 10 and with their bottom flanges level. If the installation

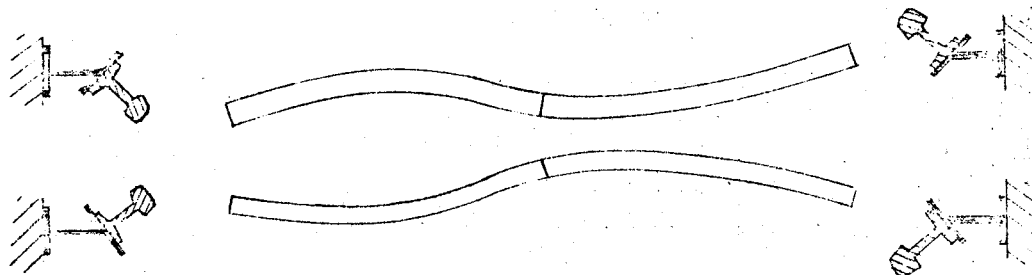

FIGURE 10. SKETCH SHOWING STEEL BEAM TOLERANCE BUILDUP

were to be made this badly the gage could vary 1.34 inches and the rail height could vary 0.85 inch! The configuration shown is highly unlikely not only because it would be difficult to arrange for the worst of everything to be in one spot, but also because the more likely case would be, instead of keeping the bottom flange perfectly level, to exert construction efforts to make the top flange or the rail head level. Nevertheless, this example does point out the importance of field installation errors and how they might compare with track profile distortion from train loads.

### Electrical Characteristics

#### Signaling

From the standpoint of the signaling system, the factor most affecting electrical characteristics of conventional track structures is the "ballast resistance"--that is the resistance between the two rails. It is equally important that the track longitudinal resistance (impedance to signaling frequencies) be as low as possible, in the order of 0.03 to 0.05 ohms of rail resistance per thousand feet. It is the combination of these two factors which governs the energy applied to the track relay. A conventional signaling system indicates the presence of a car in a section of track with the circuit shown in Figure 11. The two rails are used to complete a circuit between a battery

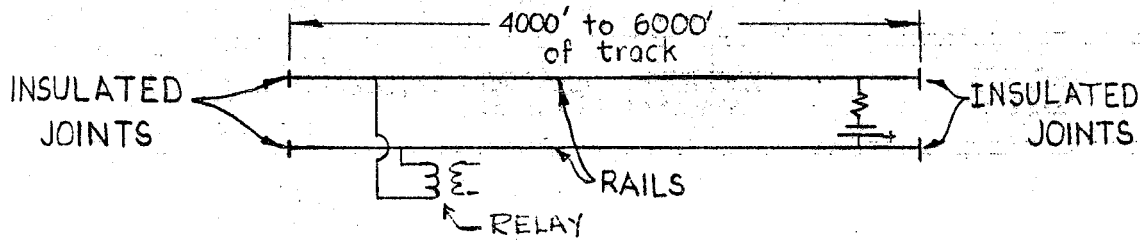

FIGURE 11. TYPICAL TRACK ELECTRICAL CIRCUIT

and the coil of a relay. With no car present in the section of track, the relay is in an energized condition. When a car is in the section of track, the two rails are shorted together by the axles and wheels of the car, the voltage across the relay coil goes to zero and the relay de-energizes, signaling the presence of a car or train.

In order for this circuit to work properly and without interference from the adjacent circuits, the resistance between the two rails through the supporting structure and ground must be at least about 1 ohm for each 1000 feet of track (preferably between 2 to 3 ohms) and there must be insulated rail joints at regular intervals of 4000 to 6000 feet. The higher the resistance between rails and/or the lower the linear rail resistance, the farther apart the insulated joints can be placed. If the resistance between rails is lower than the value mentioned the voltage across the relay coil will be low and the relay may de-energize and signal the presence of a car even though none is present.

One advantage of the above circuit is that it provides broken rail protection. If there is a break in the rail at some point in the circuit, the relay will de-energize, thus no trains will be allowed to enter that section of track.

Nonconventional signal systems are available that can be used where the rails are shorted together (as is the case when steel cross ties are used) and when insulated joints are not practical. The "check in-check out" or "count in-count out" system has been used in cases where the two rails are shorted together. This system essentially counts the cars entering a particular section of track and those leaving the section and thus determines if any cars are present. Reliability is sacrificed with a system of this type and there is no broken rail protection.

When insulated joints are not present an overlay-frequency-signaling system can be used. A schematic of a circuit of this type is shown in Figure 12. The track is divided into sections, each containing a generator and receiver tuned to a particular frequency. The frequencies of adjacent sections of track are different enough so that there is no interference or need for insulated joints.

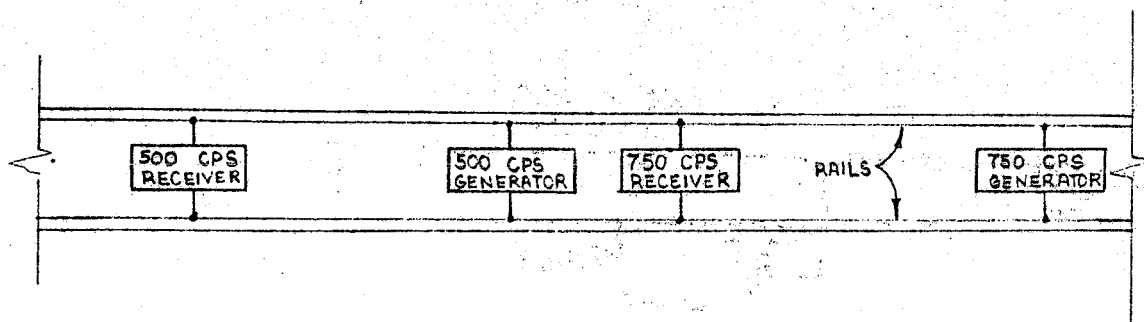

FIGURE 12. ELECTRICAL CIRCUIT FOR TRACK WITHOUT INSULATED JOINTS

### Propulsion

The important electrical parameter of the track system in relation to the propulsion circuit is the electrical-resistance impedance of the rail in the longitudinal direction. This resistance should preferably be in the range of about 0.03 to 0.05 ohms per 1000 feet, and should have the current-carrying capacity required. The higher this resistance, the closer together must be the points where the rail-track system is tied into the common or return propulsion circuit.

For conventional track structures not using continuous welded rail this requirement dictates the type of joint and bonds that must be used. For advanced track structures that use continuous welded rail, however, this requirement is not a difficult one to meet, provided that the rail contains enough steel to ensure the necessary conductance.

### Communications

The previously described signaling and propulsion aspects of the rail system are forms of communication in the broad sense. In some instances, however, there are voice communication systems which employ the rails as the transmission medium. However, these systems have been replaced by line-wire induction systems or space-radio systems so that the rails, as a voice communications medium, can be disregarded. In the case where signals are transmitted down the rails to actuate train-control or cab-signals in the locomotive or lead unit of a train, the same electrical characteristics of the rails are required as described above regarding the signaling system.

It was concluded that the most significant design requirement imposed on the track structure by electrical considerations was that the rails or rail-head be electrically isolated from each other and from the earth. This affected the fastener design, as it dictated that the fastener provide electrical insulation between rail and support structure. Specific electrical characteristics required will depend on the types of signaling, propulsion, and communications systems used in specific applications.

### FUTURE WORK

Battelle would be pleased to participate in future work leading to the detailed design of the recommended track structures, laboratory testing and development where necessary, and their earliest possible construction and evaluation in the field.

Future work recommended falls under three categories:

- (1) Detailed design, analysis, and refinement of one or more of the recommended track structures
- (2) Construction, laboratory tests, and evaluation of portions of the track structure--particularly rail attachment devices
- (3) Construction, field tests, and evaluation of the track structures under actual rail traffic as, for example, in the test section between Trenton and New Brunswick, New Jersey.

#### Detailed Design, Analysis, and Refinement of One or More of the Recommended Track Structures

The track structures recommended in this report need to be analyzed in more detail before completing the final design. For example, the designs of the rail fasteners must be completed and stresses must be carefully analyzed, based upon both installation loads and upon forces developed by the high-speed trains. For nonstandard rail cross sections the designs must be carefully analyzed so that minimum quantities of material are used while meeting allowable stress levels and also providing adequate allowance for railhead wear. The soil preparations and drainage provisions beneath the structures must be determined more completely. In addition, the procedures for field construction and for adjustment of rail alignment and elevation must be carefully determined. Based upon this additional engineering, designs can be effectively completed.

#### Construction, Laboratory Testing, and Evaluation of Portions of the Track Structures

Based on the final design resulting from Phase I above, portions of the track structures should be constructed and subjected to laboratory tests. For example, Battelle has previously conducted fatigue evaluations of rail fasteners for an industrial sponsor, using a large hydraulic fatigue tester which can provide high cyclic loads at frequencies in the range of 1 to 10 cycles per second. It would be desirable to cast sections of the reinforced



concrete beams and install rail attachment fittings with instrumentation to determine the actual stresses generated during laboratory tests in which simulated wheel loads would be applied. Based on these tests some design modifications would be made, if necessary, until satisfactory fatigue performance was obtained from the rail attachment fittings and their connections to the structure.

Construction, Field Tests, and  
Evaluation of the Track Structures  
Under Actual Rail Traffic

The proof of any design must eventually be established in field tests under anticipated traffic conditions. It is recommended, therefore, that the Department of Commerce build sections of one or two of the recommended track structures for field evaluation. It would be preferable to have sections of both tangent and curved track for these tests, but it is not believed that long sections of track would be required. Sections as short as 200 to 1000 feet in length would provide valuable information on the performance of the track structures in actual service, permitting a comparison with adjacent standard track. The similarity of the track structures recommended in this report could lead to a very economical field evaluation program in that several rail and rail attachment designs could be evaluated, possibly simultaneously, on a single reinforced concrete foundation.

For a field evaluation program both the car and the track structure should be instrumented, as the ride of the vehicle is one criterion by which the track structure would need to be evaluated. Other parameters such as stresses and deflections in the rails, rail attachment devices, resilient pads, foundation structure, and in the soil would need to be measured. Other measurements, such as trackside noise, might also be made and compared directly with similar measurements made on standard track a few feet away.

TECHNICAL WORKDescription and Analysis of  
Present Track Structure

The structure of the majority of railroad tracks in the U.S. today consists of lengths of steel rail laid end-to-end and resting on small steel tie plates which rest on wooden ties which, in turn, rest on crushed stone ballast on top of the soil (see Figure 13).

The rails are held from moving sideways relative to the ties and to each other by shoulders on the tie plates and by cut steel spikes which are driven into the ties through holes in the tie plates. The rails are held from moving longitudinally by rail-tie plate-tie friction, and in many cases by "rail anchors". The lattice of rails and ties is held from moving in the horizontal plane mainly by its own inertia and by the friction of the ties on the ballast. The rails and ties are held to the ballast only by gravity.

Under the pounding of traffic and the cycles of weather the track structure deteriorates. The rails flex under passing wheels and their undulation works the spikes loose from the ties. Until respiked, the rails thereafter are free to bend vertically and lift off of the ties. With the repeated loading imposed on them, which is often impact-like, the ties are beat down into the ballast, pushing the ballast both up between the ties and down into the finer subsoil beneath, which tends to shift and sift upward into the ballast. This tendency of the ballast and subsoil to migrate and mix has two effects on the structure: it undermines the ties and it fouls the ballast. The latter happens because the finer soil plugs the voids in the ballast and inhibits the drainage of water through it. When the ballast or subsoil immediately beneath it is holding too much water, the undulating action of the traffic loads tends to pump mud upward, fouling the ballast still more and impairing the stability of the ballast and subsoil as a foundation. Along the track, different soils and ballasts (which have been compacted and/or stabilized to different degrees and by different means originally) deteriorate at different rates. The net effect is an uneven shifting and settling of the whole track structure, and the disruption of its stability. Consequently the deterioration accelerates.

Eventually the rails become so misaligned and their support so weakened that the structure cannot serve its purpose safely and adequately. It is necessary to realign, refasten, and raise the rails, and to clean and redistribute or replace the ballast regularly in order to maintain the integrity of the track structure. It is also necessary to periodically replace or repair rails, ties, and fasteners due to the damage they sustain while operating under dynamic loading in a misaligned, partially deteriorated condition. Most of this damage is the result of inconsistencies in the support of the rail-tie lattice, such as at rail joints, ties whose ballast has sifted out from their ends, and ties which have been pushed down so that they are completely out of contact with the rail.

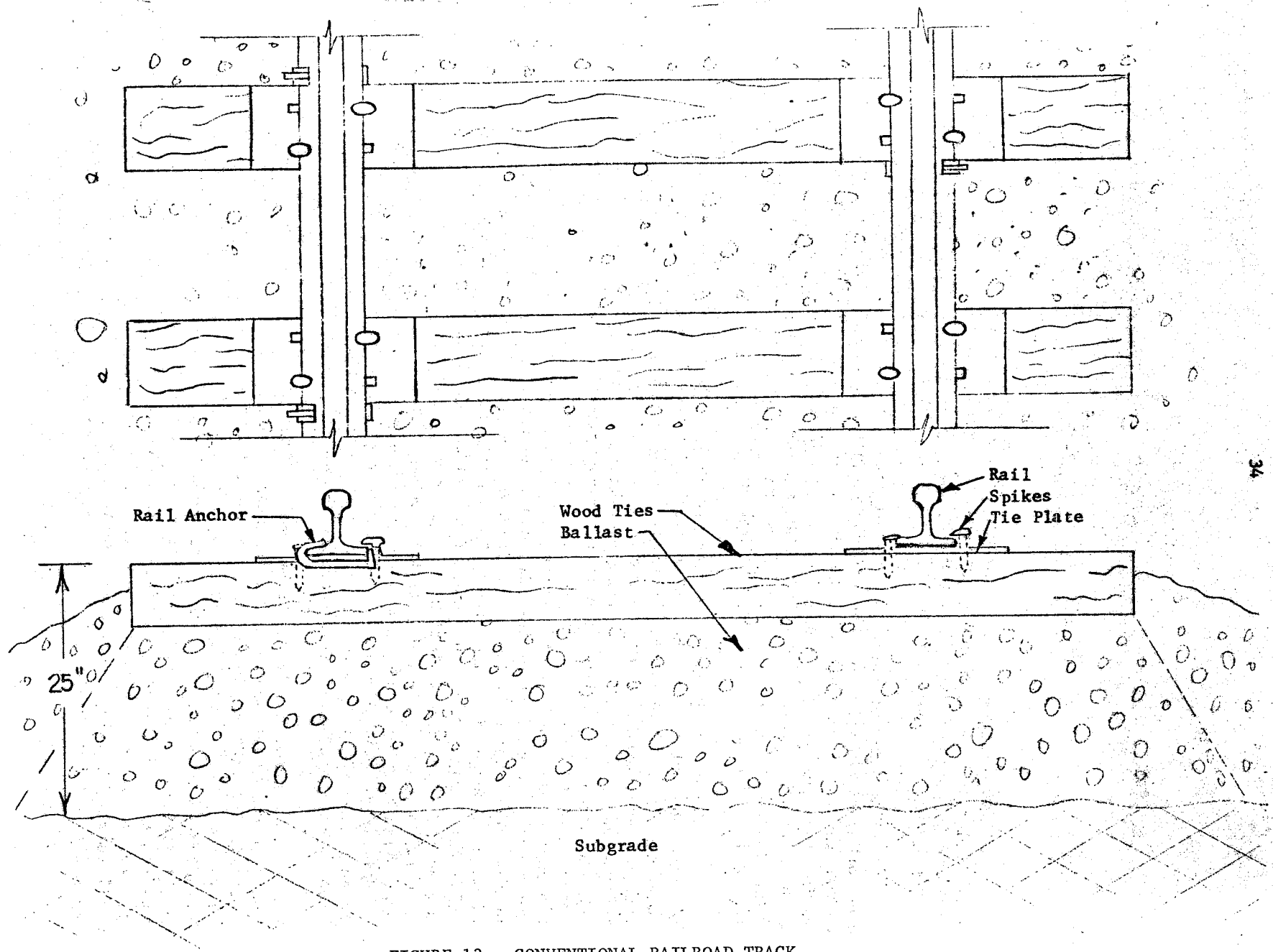

FIGURE 13. CONVENTIONAL RAILROAD TRACK

### Past Efforts at Improvement of the Track Structure

Continuous welded rail (CWR) is being used by most railroads. Besides the added structural continuity, CWR has the advantages of lower capital cost, reduced equipment maintenance, lower maintenance-of-way costs and, under many conditions, longer life than short rail lengths. In places where CWR is not justified, some railroads have been using epoxy-bonded bolted rail joints which, unlike CWR, have the advantage of easy rail replacement without interruption of traffic.

Rail fasteners other than the traditional spike and steel tie plate have been tried, but none generally accepted. The spring-type fastener is gaining popularity, however. The function of any rail fastener in the present tie-and-ballast system is to absorb or withstand the wave motion of the rail, transfer the rail motion to a material capable of hysteresis (such as wood or an elastomer) which cushions the wheel load shock to the rail supports, longitudinally anchor the rail from expansion and contraction with temperature (in the case of CWR), provide some lateral flexibility, and yet hold the track in alignment.

There are two sound reasons for not fixing the rail rigidly to the ties. First, when the ties are rigidly connected to an undulating rail they become large tamping devices, continually rocking in, impacting, and abrading the ballast. Second, when the tie is relatively fixed, and the rail is restrained from rocking over it and lifting away from it, the fastener is subjected to higher cyclic stresses. This fastener problem was the cause of a serious derailment on, and the subsequent abandonment of, a rigid concrete roadbed extensively engineered by the Pere Marquette Railroad<sup>(2)</sup> in the late 1920's. The dynamic rail stresses in this system were less than one-half those in conventional track structures, and no significant movement, settlement, or deterioration of the reinforced concrete slab roadbed occurred over 10 years. However, the tight fastening devices broke off often under the fatigue stresses.

Some efforts have also been made to improve or eliminate the wooden ties. Concrete ties are used in Europe frequently (where wood is more scarce than in this country) and in Japan's high-speed Tokaido line, with good results.

In this country a few efforts have been made in the past to protect the rails from the inherent local instability of the ballast and subsoil by using various combinations of rigid roadbeds. Some fix the rail to wood ties as before, but use a concrete or asphalt pavement either directly under the ties or directly under the ballast. Others have eliminated the ties and fixed the rail directly to concrete beams or slabs. Most of these have been successful improvements, but the practice has not been more extensive because of the cost. Those installations that have failed have apparently done so not because of soil deterioration, but because of the weakness of the other components in the structure, such as wooden ties and steel spring clip fasteners, which were not the weakest links in a conventional tie-and-ballast system, but come to be so as the roadbed is made more rigid and less sensitive to the supporting soil's properties.

Elastomeric tie pads between the rail and tie plate and/or between the tie plate and tie are used by some railroads, primarily to prevent the abrasive wear of the wooden ties. They are also used in some subway installations to reduce noise. Their use on rigid concrete or continuous roadbeds is necessary to reduce the stress concentration on the concrete. Resilient tie pads more than compensate for the natural resiliency of wooden ties and stone ballast, but there has been no specific understanding as to how much resiliency is desirable in the system. A stiffer track has the theoretical advantages of a better load distribution to the soil foundation, lower rail stresses, lower power consumption by traffic, and possibly better high-speed ride qualities. It has the disadvantages of inherently high dynamic force transmissibility, greater difficulty in adjustment of the roadbed level and, so far, a greater fastener mortality rate due to fatigue, unless properly designed.

#### Basic Future Improvements Desired

As a system, the track structure would be improved by anything that gives it greater structural continuity and dimensional stability under load. The use of continuous rails is a step in the right direction, but their beam rigidity is insufficient to bridge major discontinuities in the roadbed beneath them. Replacing wooden ties by concrete ones is another step in the right direction, because concrete ties are five times as heavy and so serve primarily as better anchors. However, it is a small step at most, because when the railroads have used them they have spaced them farther apart, thereby supporting the load on the ballast over a smaller area and effectively weakening the overall system stability.

It would seem that the best way to live with the soil would be to give it the smallest job possible--that is, to distribute the load over as wide an area in as uniform a manner as practical. This means that an advanced track structure must not only have continuity at the rail level, but also below the rail to such a depth and breadth that the soil is insulated from the changes of the elements and feels a minimum and uniform pressure, even under traffic.

No matter how rigid or consistent the track, the earth itself is not a stable platform, so some dimensional instability is inevitable. Therefore, the rails must be adjustable vertically and laterally relative to their supporting structure to be able to compensate for slight discrepancies that may result from initial misalignment, and from settling or heaving of large bearing areas of the soil.

#### Forces Acting on the Track Structure

The basic function of the rail-roadbed structure is to support and guide trains. As it performs this function, vertical, lateral, and longitudinal forces are developed at the wheel-rail interface. In addition to the loads imposed by the wheels, the track structure must withstand thermal expansion and contraction forces which act on it continuously.

Conventional track and roadbed deteriorate under the action of these loads. The basic requirement of an improved track structure is that it be designed to withstand these loads for years without deterioration. One of the first steps in this track structure design problem, then, was a force analysis to determine the general magnitude and direction of all forces imposed on the track structure--including the supporting soil.

Forces Developed by Wheel Loads. The forces transmitted to the rail from the wheel are:

- (1) Vertical forces due to the weight and dynamic wheel loads of the train
- (2) Lateral forces composed predominantly of the forces due to "hunting" of the truck and the force necessary to guide the wheels on curves
- (3) Longitudinal forces imposed by the wheel in accelerating and decelerating the car and in overcoming frictional losses.

To determine these forces the new Budd passenger car ordered by the Pennsylvania Railroad for its high-speed demonstration runs was used as a representative vehicle. Pertinent specifications of this vehicle are as follows:

- General: 2 to 20 individually powered cars per train
- Weight of cars at rails, loaded: approximately 180,000 pounds
- Car length: 85 feet
- Truck center distance: 59 feet, 6 inches
- Distance between truck centerline of adjacent cars: 25 feet, 6 inches
- Distance between wheels in truck: 8 feet, 6 inches
- Maximum operating design speed: 160 mph.

For the Budd car, then, the average static vertical wheel force imposed on the rail is 22,500 pounds. The increase in vertical force due to track irregularities, load shift on curves, and other causes can be estimated using a dynamic impact factor,  $\psi$  (3). For well-maintained track at 160 mph,  $\psi$  is about 2.0, so the maximum vertical force (at this point in the analysis) was estimated to be on the order of 45,000 pounds. Note that the passenger car weight of 180,000 pounds is not too much less than that of the newest "high-cube" hopper cars, which are designated as 100-ton capacity and weigh in at somewhere around 250,000 pounds fully loaded with coal. A track structure designed to this rather high passenger car load should, therefore, be able to handle much freight traffic as well. On the other hand, this seems like an excessive weight for a future car designed specifically for high-speed service because, although it provides greater stability, it also imposes penalties not only on the track structure but on propulsion and braking components of the vehicle itself.

The wheel loads can be considered as point loads moving at some longitudinal velocity along the rail. At any particular point along the rail, the rail structure and the roadbed experience a periodic loading as the train passes. The period of these variations is equal to the time it takes for one car to pass a particular point.

The lateral forces acting on the rail can be calculated from the so-called "derailment quotient", which is the ratio of lateral-to-vertical force on the rail. The value of derailment quotient greater than about 0.8 will result in derailment<sup>(4)</sup> and an average operating value is about 0.40<sup>(5)</sup>. From these values of derailment quotient, the average lateral force from the Budd car wheels is 9000 pounds, and the peak lateral force is 36,000 pounds. The variation of the lateral force with time, at any point on the rail, is not easily predicted. However, for design purposes, it can be assumed that at some time every point on the rail will be subjected to a lateral force of the magnitudes mentioned; the track structure should, therefore, be designed to withstand this force without failing or deflecting excessively.

The longitudinal wheel force acting on the rail is generated by the friction between the wheel and rail, and cannot exceed the coefficient of friction times the vertical force on the rail. The maximum coefficient of friction is obtained with sand on a dry rail and is quoted to be about one-third. Thus, an average value of longitudinal force is  $1/3 \times 22,500$  pounds, or 7500 pounds, and the peak value is  $1/3 \times 45,000$  pounds, or 15,000 pounds. Obviously, the longitudinal force on the rail is not of this magnitude at all times. During normal, constant speed operation, the force will be considerably less than this, but during acceleration and particularly during emergency deceleration the force can reach these values and the rail-roadbed structure must be designed accordingly.

Forces Developed by Temperature Changes. Of a much greater magnitude and, therefore, more important than the longitudinal forces caused by the wheel, are the longitudinal forces caused by thermal expansion or contraction of the rail-roadbed structure. The thermal force acting on a steel rail, assuming that the rail is completely restrained from expanding or contracting, is

$$F = 201 \times A \times \Delta T \quad (1)$$

or

$$F/A = 201 \Delta T$$

where  $F$  = force in the steel rail, lb

$A$  = cross-sectional area of rail, in.<sup>2</sup>

$\Delta T$  = change in temperature, F.

For a rigidly restrained A.R.E.A. 140-pound rail, a 70 F increase in temperature causes a force of 194,000 pounds and a compressive stress of 14,000 psi. If the

rail is allowed to expand to some extent, because of the rail gaps and flexible restraints, there will be less expansion force in the rail. This force will be sustained by the rail's fastening devices and will be determined by the flexibility of the fasteners. Although the rail wants to expand longitudinally, it will have a tendency to buckle in any direction in which it is not restrained, so the rail fasteners must also withstand lateral and vertical forces generated by thermal effects.

### Mechanics of Transferring Wheel Loads to the Soil

Using the results of the force analysis described above, the actual mechanics of how these loads are transferred through a track structure to the ballast and soil was investigated, starting with conventional track to provide a reference point.

Figure 14 illustrates a conventional track structure consisting of rail, tie plates, cross-ties, and ballast. Assuming continuous rail is used, or that the rail joints have good integrity, the wheel load on the rail in conventional systems is distributed over many ties because of the bending stiffness of the rail. The individual ties then transfer the load to the ballast. Figure 15 shows the theoretical pressure at various depths in the ballast caused by a vertical load on the rail. At a depth of about 24 inches the load is essentially evenly distributed over a wide area of the ballast, and is of a uniformly low magnitude. Although the actual load distribution is a function of the condition of the ballast, experimental results reported in the literature<sup>(6)</sup> indicate the assumption of uniform load yields calculated pressures only slightly lower than ballast pressures measured in actual roadbeds. When used as design values for pressures under advanced track structures, this assumption leads to a degree of conservatism, since actual pressures in conventional track are somewhat higher, depending on the uniformity of the ballast supporting the ties.

Typical static stiffness properties of the components of a conventional well-maintained track structure are summarized in Figure 14. The overall stiffness of the structure at the railhead can be calculated by considering the rail as a continuous uniform beam, and everything below the rail as a continuous elastic foundation. The stiffness per unit length of this continuous elastic foundation can be obtained by determining the stiffness at the top of one tie if the rail were not present. This stiffness is the series equivalent of the tie, ballast, and subgrade stiffnesses, and when it is divided by the tie spacing it becomes the stiffness per unit length of the continuous elastic foundation.

The static deflection of a continuous beam on a continuous elastic foundation at distance  $x$  to either side of a fixed point load,  $P$ , is

$$y(x) = \frac{P\beta}{2K} \alpha(x) \quad (2)$$



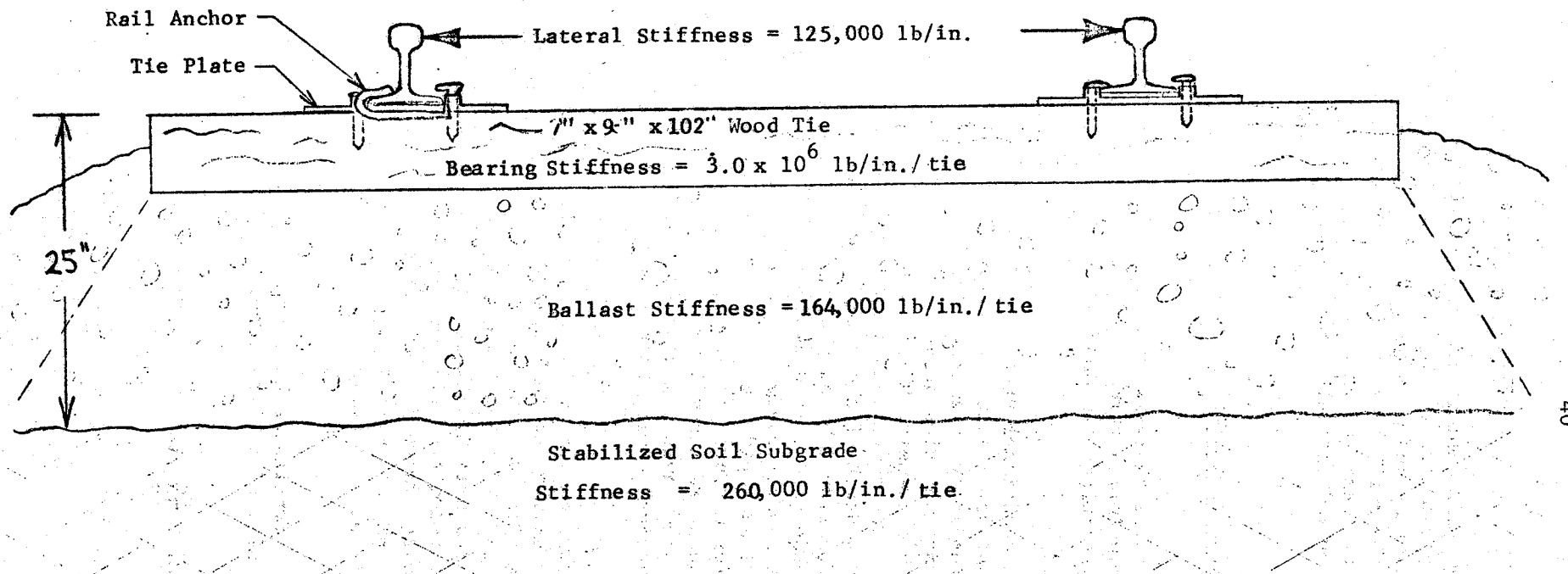

(a)

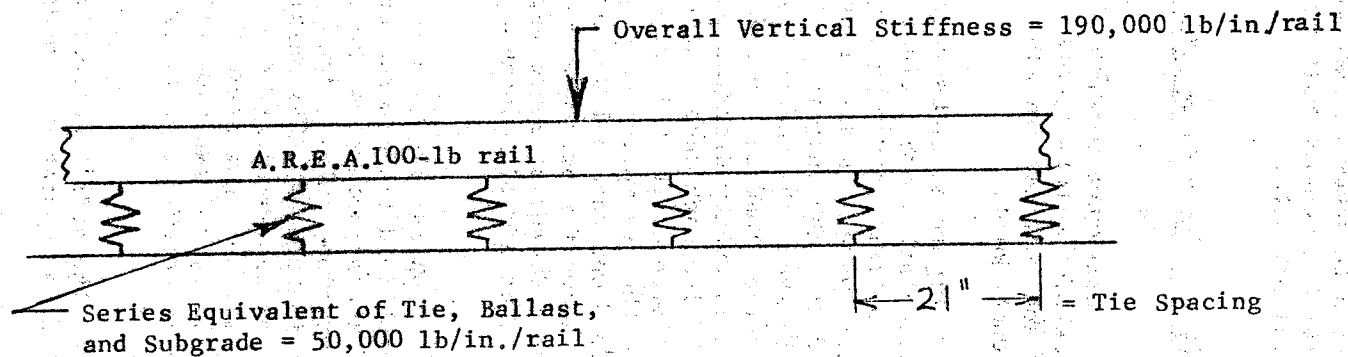

(b)

FIGURE 14. TYPICAL STIFFNESS VALUES OF CONVENTIONAL TRACK ASSEMBLY

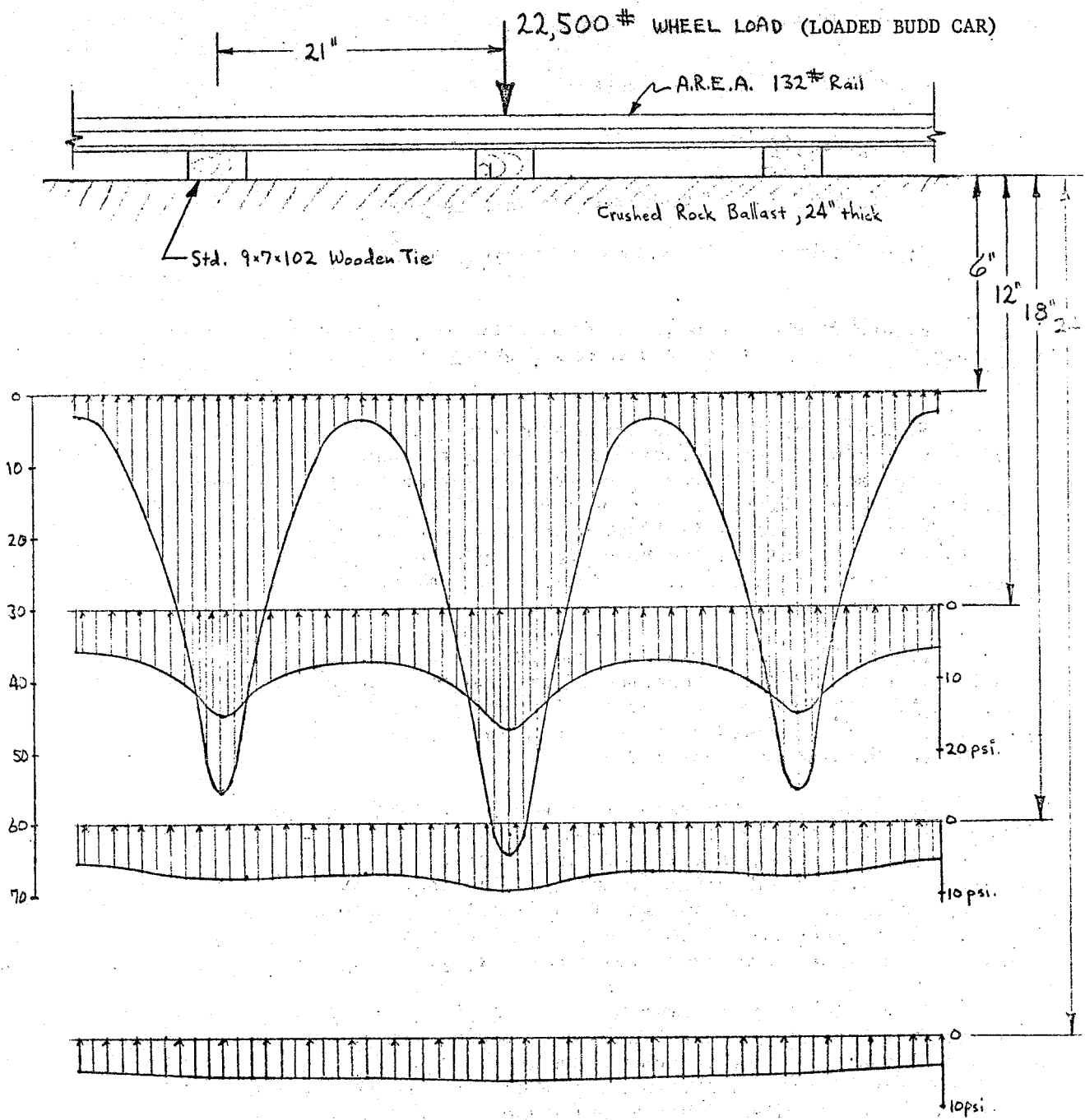

FIGURE 15. PRESSURE DISTRIBUTION AT VARIOUS DEPTHS BENEATH TIES

where  $P$  = magnitude of point load, lb

$$\alpha(x) = e^{-\beta x}(\cos\beta x + \sin\beta x) \quad (3)$$

$$\beta = (K/4EI)^{1/4} \quad (4)$$

$K$  = foundation stiffness per unit length, psi

$EI$  = flexural rigidity of the rail, lb-in.<sup>2</sup>

Figure 16 shows a plot of  $\alpha(x)$ , based on Equation (3). The deflection is the same on either side of the load and for practical purposes vanishes for  $\beta x > 2.0$ .

Figure 17(a) shows the calculated vertical stiffness of the track structure as a function of foundation stiffness for three standard rails. Note that the total stiffness is very dependent on foundation stiffness but is fairly independent of the rail size. The overall stiffness at the rail head for the typical system in Figure 14 is 190,000 lb/in. for each rail. However, changes in the type of soil and weather conditions cause the soil or subgrade modulus to change, with the result that the overall spring rate may vary from 25,000 lb/in. to 800,000 lb/in.

Figure 17(b) shows the maximum bending stress in the rail per pound of vertical wheel load as a function of the stiffness of continuous elastic foundation, for three standard rails. It can be seen that the bending stress in the rail is fairly insensitive to the stiffness of the foundation, but is quite sensitive to the size of the rail.

The lateral stiffness of a conventional track structure is between 100,000 lb/in. and 150,000 lb/in., depending on the type of tie, base plate, and rail fastener. This is the stiffness when both rails are equally loaded in opposite directions as shown in Figure 14. The entire rail-tie lattice is restrained from lateral motion mainly by friction (and some shear) of the ballast. Entire sections of continuously welded track sometimes buckle when expansion forces due to temperature changes exceed the ballast-tie friction.

In considering the transfer of loads from the railhead down through a track structure and into the ballast and subgrade supporting the structure, it was apparent that the ballast and subgrade were the limiting factors, and the ones whose characteristics were most difficult to define, as indeed they may vary daily. The decreased dimensional stability of conventional track structures at progressively higher train speeds is caused in large part by the instability of the ballast-roadbed foundation under the periodically varying bearing pressures produced by wheel loads.

A typical plot of the time-varying pressure at a point in the ballast directly below a cross tie is shown in Figure 18. The pressure increases to some maximum value as a wheel approaches and then decreases after the wheel has passed, the pattern being repeated for every wheel in the train. The frequency at which this rise and fall in pressure occurs is directly proportional to the

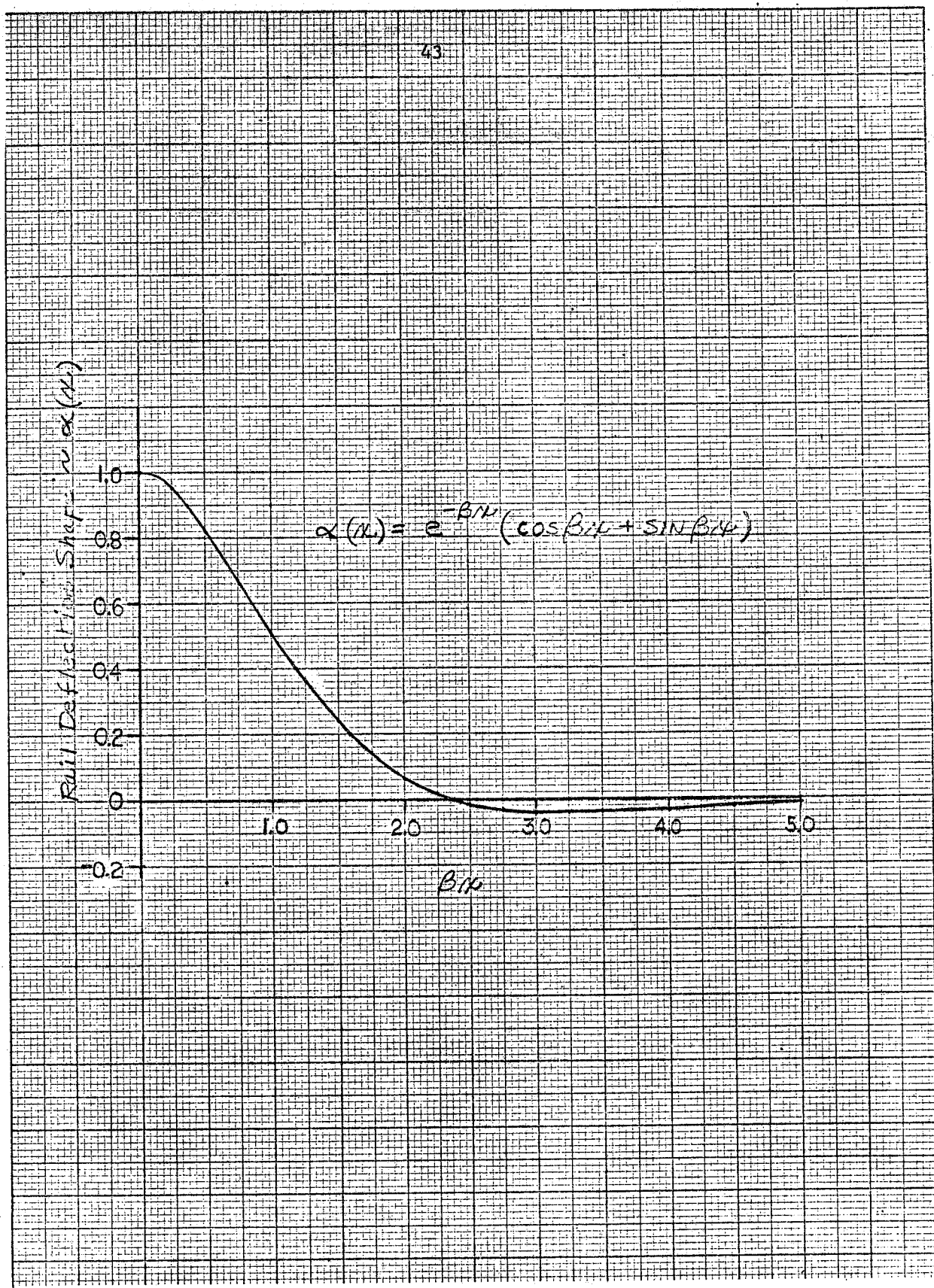
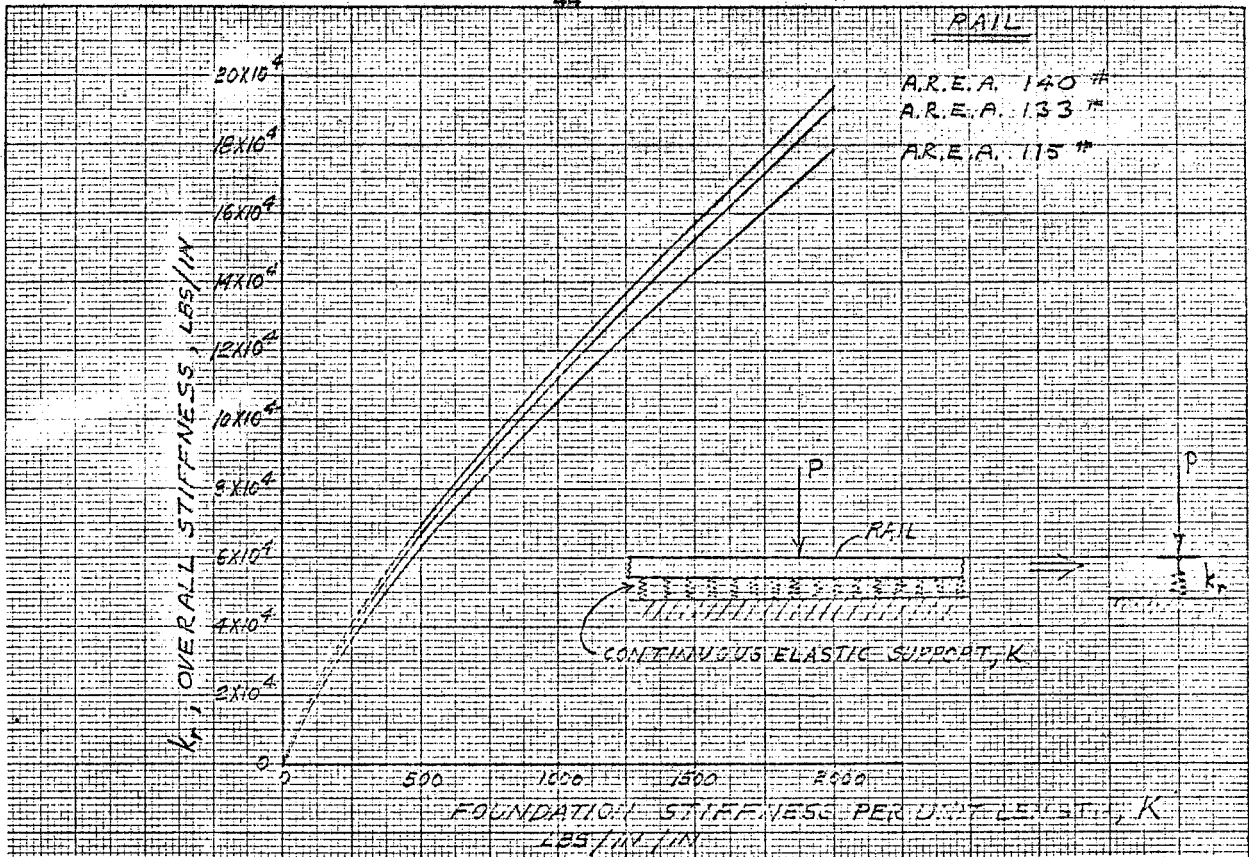
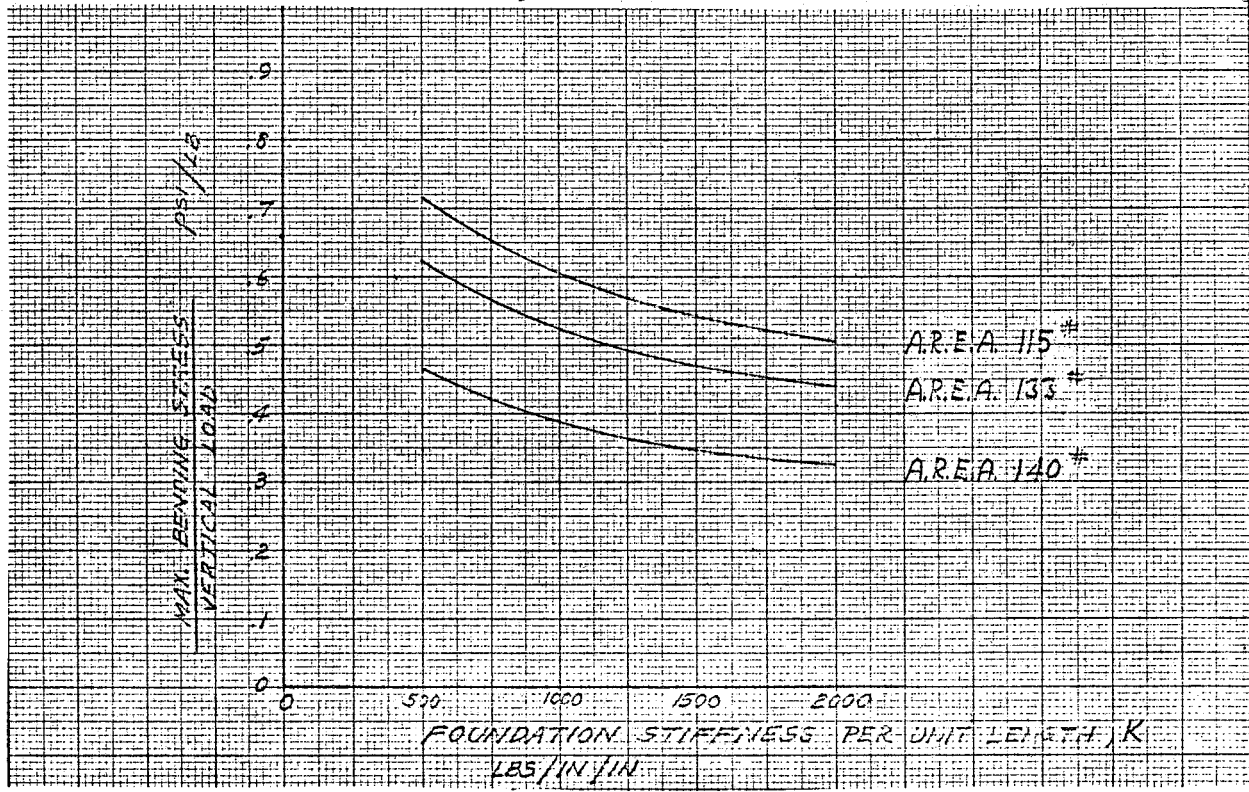

FIGURE 16. RAIL DEFLECTION SHAPE FOR A STATIC POINT LOAD<sup>(7)</sup>



(a) Stiffness of Track Systems



(b) Stress in Rails

FIGURE 17. EFFECTS OF RAIL SIZE AND FOUNDATION STIFFNESS ON TRACK STRUCTURE

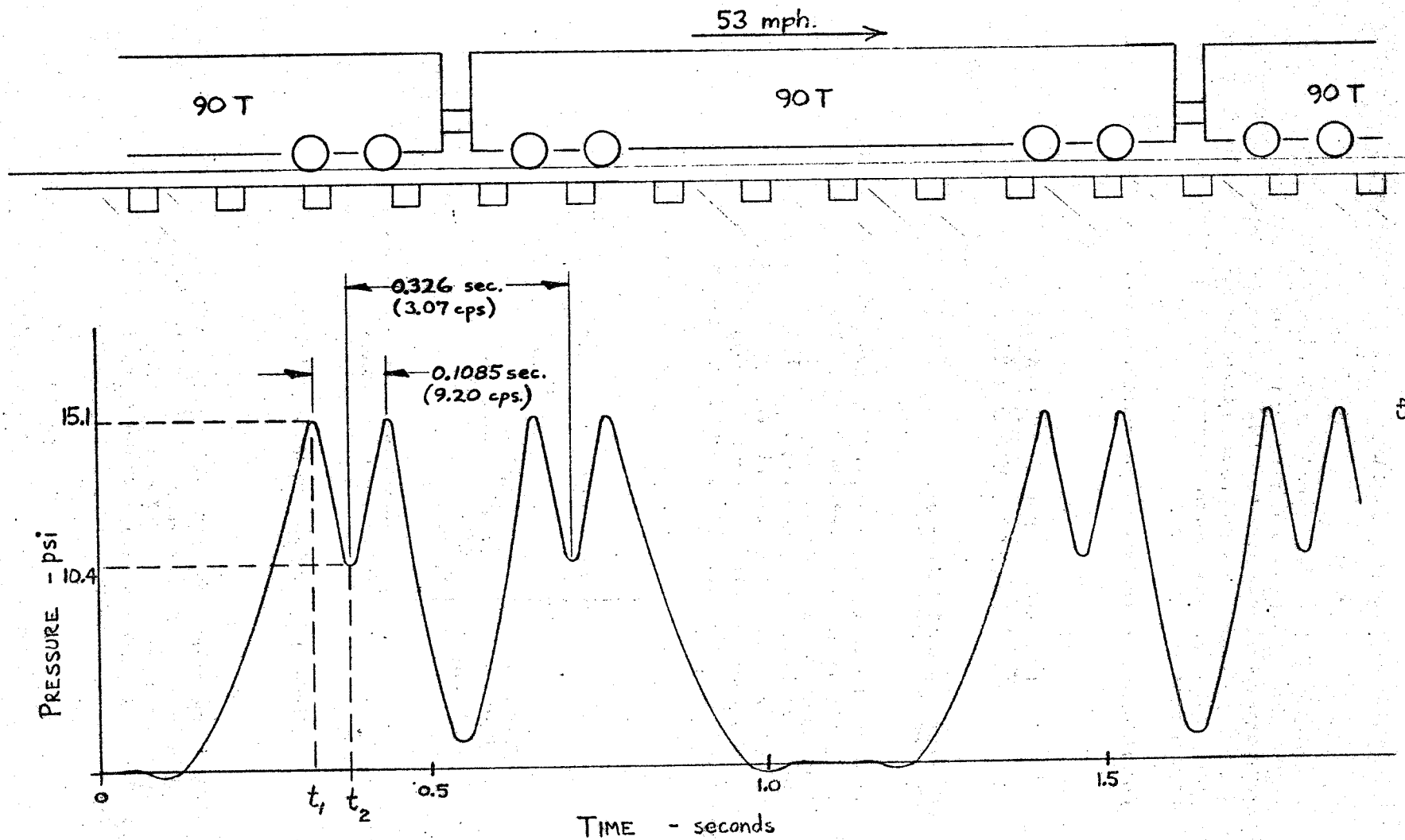

FIGURE 18. TYPICAL PRESSURE-TIME CURVE FOR PRESSURE DIRECTLY UNDER A TIE OF A CONVENTIONAL TRACK STRUCTURE

train speed, and at the high train speeds of interest the frequency of the soil pressure cycles under conventional track would be proportionately higher. To design a track structure, then, on the basis of the allowable static bearing capacity of the soil would be a dangerous mistake because bearing pressures applied at the higher frequencies have a much more detrimental effect than the same pressures applied statically.

For this reason the dynamic properties of soils were investigated.

Properties of Soil, Including Effects  
of Cyclic Loads and Moisture Content

Effect of Moisture on Soil Properties

In order to satisfactorily predict the physical characteristics of the soil, the soil moisture content must be known. Only when the moisture content of the soil is known can a reasonable degree of confidence be realized in prediction of the soil behavior. Unfortunately, these conditions are rarely met. The soil moisture content varies greatly depending on the topograph setting, geologic factors, and the rainfall; thus, the physical nature of the soil varies also. The extent of this variation can perhaps best be represented by Figure 19.

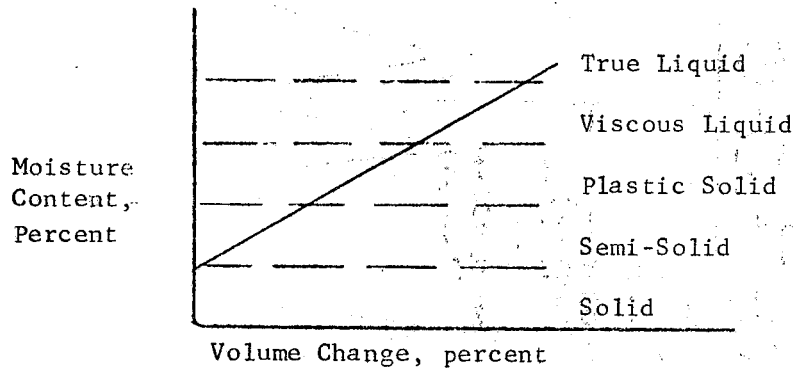

FIGURE 19. EFFECT OF SOIL MOISTURE ON VOLUME

The basic fact that soil volume is a function of moisture content applies to most soils; only the slope of the curve will change. (Pure sands are an exception and are excluded from most of this discussion.) This means that a track structure built over certain types of soil, particularly clay, could shift due to soil volume changes caused by changes in the soil moisture content.

Likewise, the strength of soil is affected by moisture conditions, increasing as the soil mass gradually obtains a higher relative density due to consolidation. That is, an increase in density is accompanied by a reduction in the volume of void space between the soil particles. The higher the density, the less water a given volume of soil can hold. Therefore, soil volume and strength are functions of the moisture content, which must be controlled if soil properties are to be predictable.

### Effect of Cyclic Loading

Although much is known about the static load-bearing capabilities of the soil, the prediction of dynamic properties is less exact. Considering the strength of soil under repeated cyclic loading, there is evidence in the literature<sup>(8)</sup> which indicates that soils have an endurance limit similar to that of ferrous metals subjected to fatigue loading. The soil may withstand a large number of load cycles with no apparent excessive deformation, and then fail suddenly. This is illustrated by Figure 20.

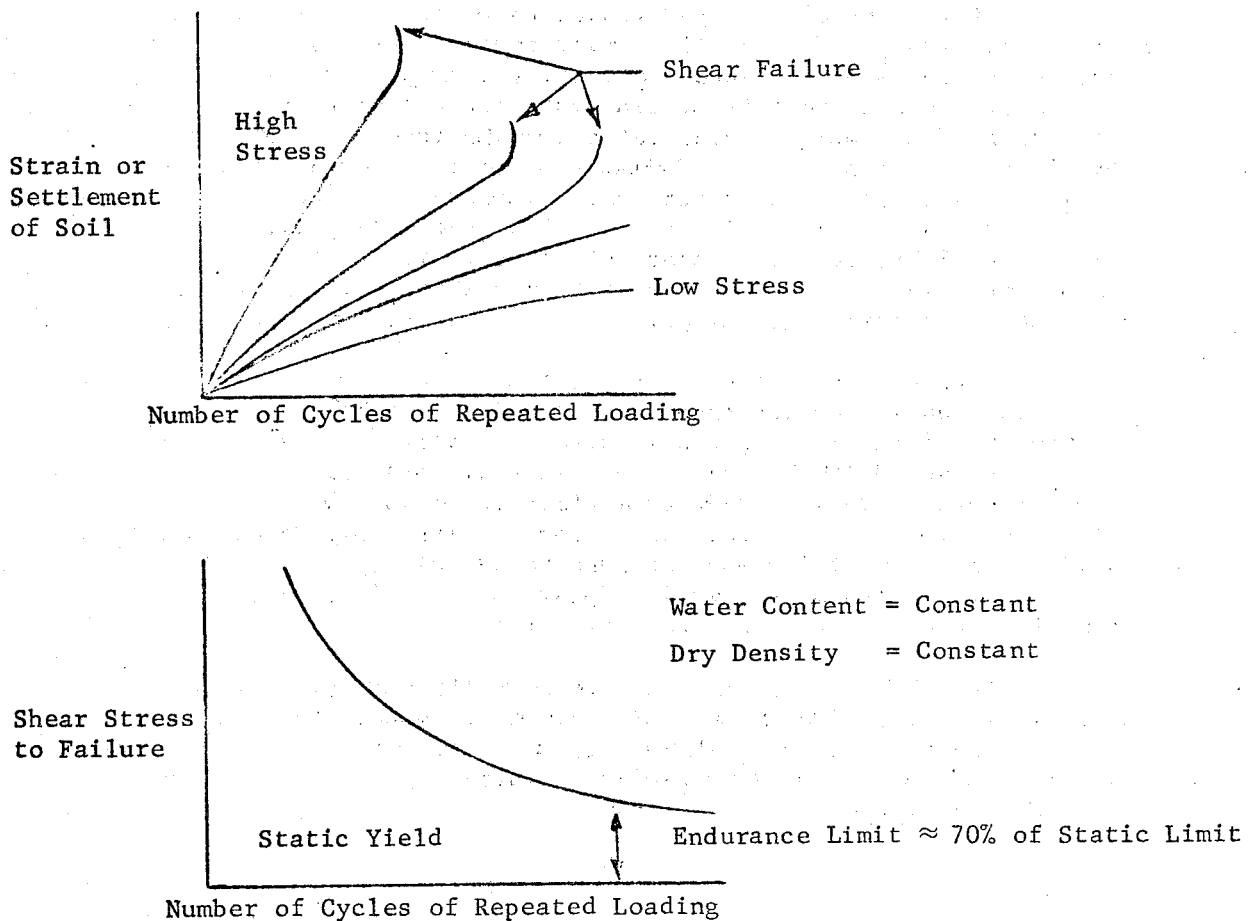

FIGURE 20. PROPERTIES OF SOIL UNDER CYCLIC LOADING



The limited information available from laboratory tests indicates a dynamic shear stress on the order of 70 percent of the static shear strength is the apparent endurance limit stress; i.e., a greater stress will eventually result in shear failure of the soil mass.

#### Effects of Magnitude and Frequency of Soil Pressure on Settlement

At very low frequencies (0 to 3 cps) deformation of partially saturated soils (the most common field condition) under dynamic loading depends primarily on the number and intensity of stress applications. When frequencies are higher, both the magnitude of the pressure on the soil and the frequency of the fluctuations will affect the degree of settlement of the soil. This occurs due to the fact that soils have natural frequencies or a "critical range of frequencies" (9-11). The greatest rate of settlement will occur when the soil is loaded with a cyclic pressure that varies at the soil's natural frequency, as shown in Figure 21.

It is generally agreed that the soil natural frequency is a property of the soil alone, and is different from what might be called the natural frequency of the system. The natural frequency of the system is a property of the combination of the soil and, say, a large mass resting on top of it--or, as in the case of a track structure, the combination of the soil and a continuous flexible beam resting on it. No matter what components comprise the entire system, the soil possesses a natural frequency of its own, and the severity of the loading on the soil will depend on how near the applied frequency is to the soil's natural frequency. A practical application of this property of the soil is found in soil tamping and compacting machines, which are designed to vibrate at the soil's natural frequency to obtain the most compaction and settlement.

Natural frequencies of soils range from about 15 cps for marshy soil to about 34 cps for undisturbed sandstone<sup>(10)</sup>. The average natural frequency for most types of sands and gravels is about 23 cps, and it is evident that the frequencies caused by the wheel loads of a train should not be in this range. The wheel spacing for the Budd car (8 feet, 6 inches between wheels on the same truck) would, on conventional track, cause a large pressure fluctuation at 27.6 cps when traveling at 160 mph. Because this falls directly in the range of soil's natural frequencies, it is expected that this will cause extremely rapid deterioration of the ballast and subgrade.

For this reason, it was concluded that any new track structure to be used for high-speed trains must be designed so that the soil does not experience pressure fluctuations for each wheel, but only for each truck. That is, the pressure-time curve should be similar to that shown in Figure 22, rather than that shown in Figure 18.

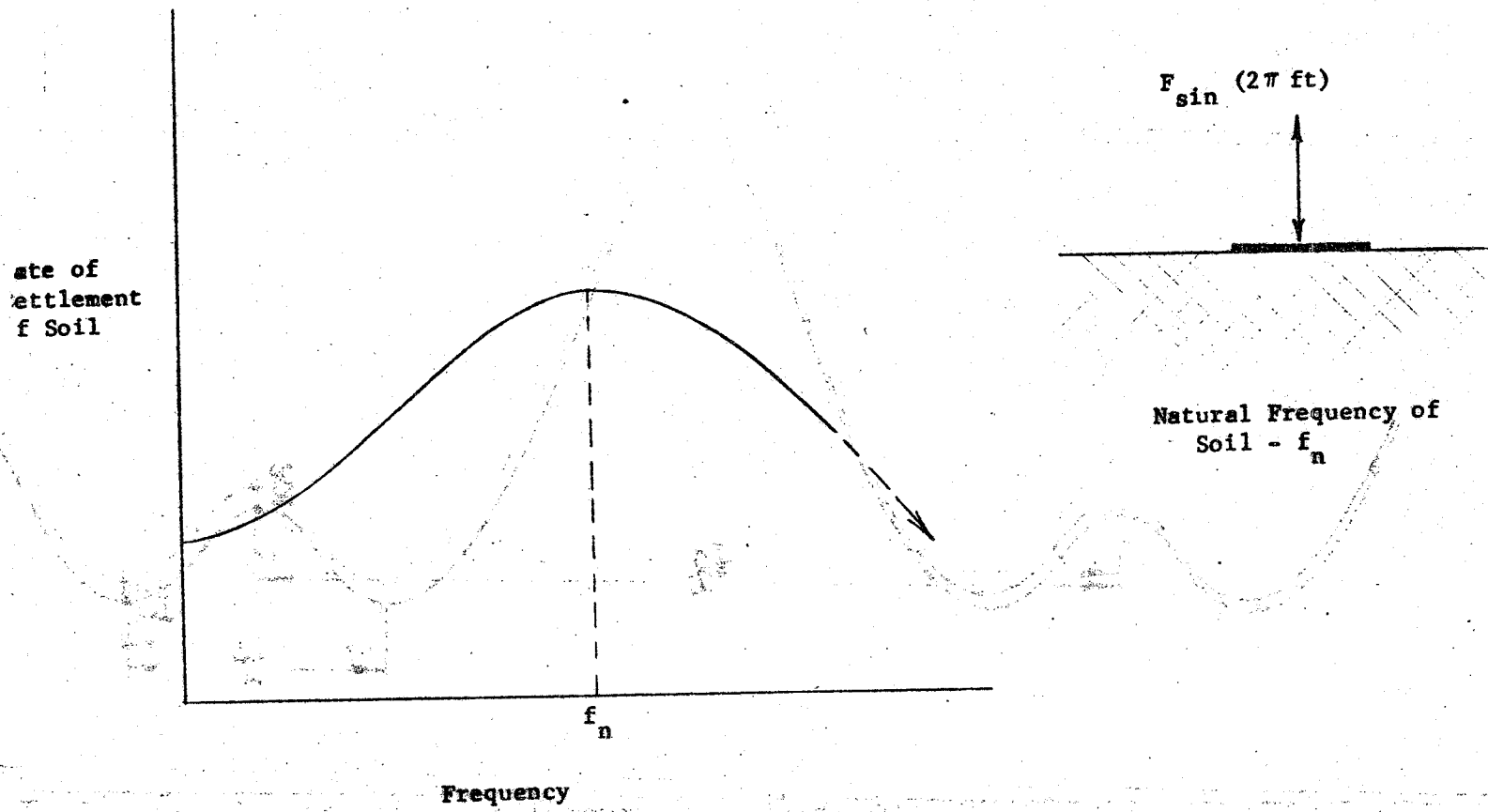

FIGURE 21. RATE OF SETTLEMENT OF SOIL AS A FUNCTION OF THE APPLIED FREQUENCY OF A CONSTANT MAGNITUDE PRESSURE

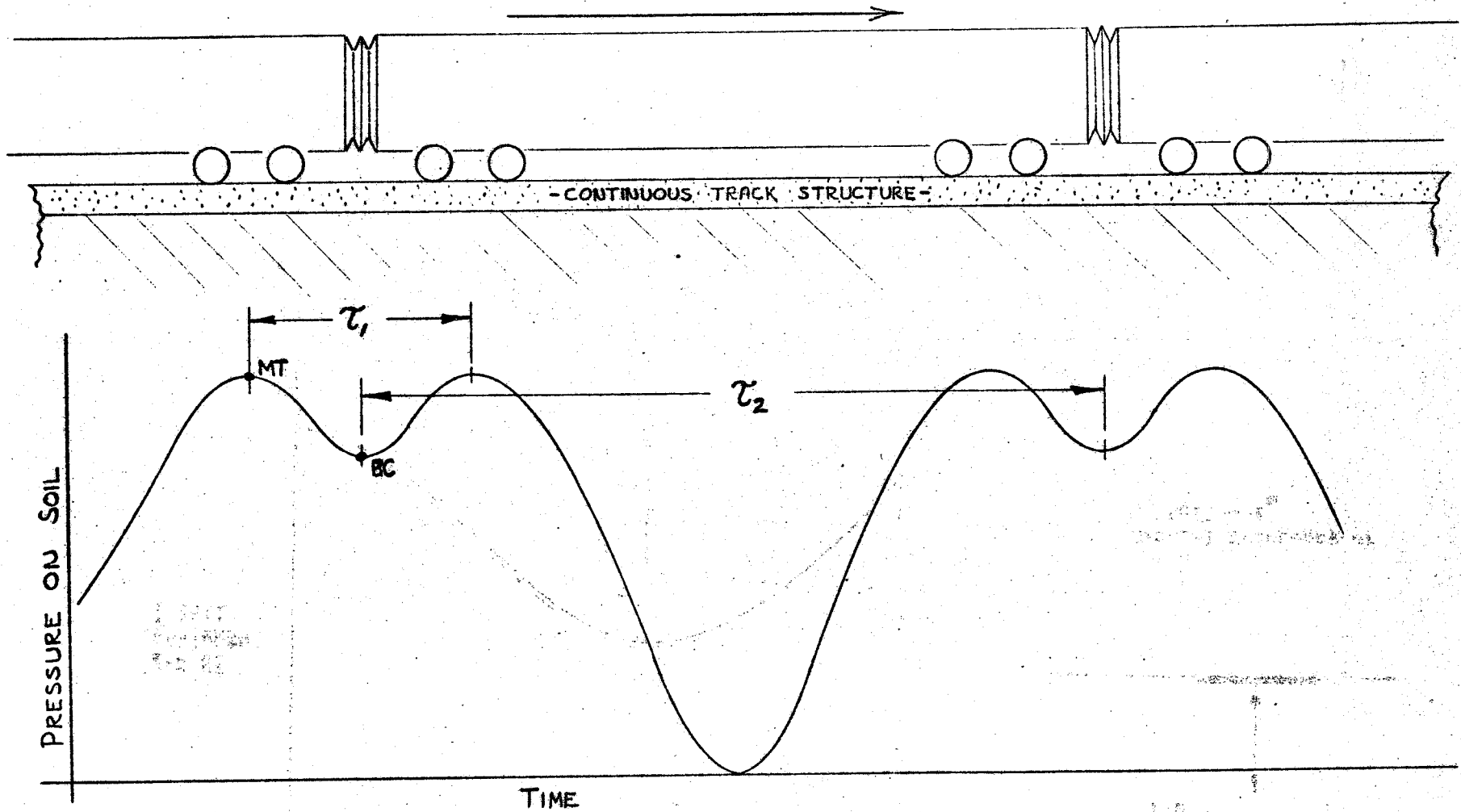

FIGURE 22. PRESSURE-TIME CURVE EXPERIENCED BY SOIL BENEATH A FAIRLY RIGID TRACK STRUCTURE (NO PRESSURE FLUCTUATIONS FOR INDIVIDUAL WHEELS).

Design Criterion for Track Structures  
for High-Speed Trains Based on  
Allowable Time-Varying Soil Pressures

Based on this analysis of conventional track structures and dynamic soil characteristics, a design criterion was evolved from the basic objective of imposing the least hardship on the soil supporting the track structure. This can be done by keeping the amplitudes and frequencies of pressures transmitted to the soil as low as practical.

This basic objective can be met by using longitudinal beams to distribute the wheel loads over a large area of soil and thereby decrease both the amplitude and frequency of the bearing pressure on the soil. The extent to which a longitudinal beam does this is dependent on its bending rigidity, on its width resting on the soil, and on the resilience of the soil ("modulus of subgrade reaction"). A relationship between these parameters and the time-varying pressure on the soil beneath the beam was developed, and this relationship expanded into a design criterion, a detailed discussion of which follows. The criterion has been used to design and analyze longitudinal beam-type track structures.

The development of this design criterion enabled track structures of greatly differing design to be compared on a quantitative basis. After sizing the designs to meet the design criterion, they were compared on a cost basis, since in the final analysis the cost-performance balance will determine the selection of an improved track structure.

Different track structures, using longitudinal beams to support the rails, can have similar pressure-time curves. As shown in Figure 23, a deep, narrow structure has high bending rigidity and distributes the wheel loads longitudinally over a large area, whereas a shallow, wide structure distributes the loads over a large width. The resultant two pressure-time curves are similar, with the peak pressure the same in both cases. The goal of generating only one pressure pulse per truck, rather than two, can be attained with either design by making the track structure sufficiently rigid.

Predicting Settlement Rate of Soil

The first step in the development of the design criterion was to derive a quantitative relationship between the imposed cyclic pressures and the settlement of the soil; the settlement rate of the soil was the parameter that was used to compare different pressure-time curves. Ideally, the settlement rate under the track structure can be predicted if the pressure-time curve is analyzed as to its frequency content and pressure amplitude at each frequency, and if the settlement rate curve (Figure 21) is well known for the soil of interest. In practical terms, however, this is unrealistic, and for this reason mathematical approximations were made of both the pressure-time curve and the settlement rate curve.

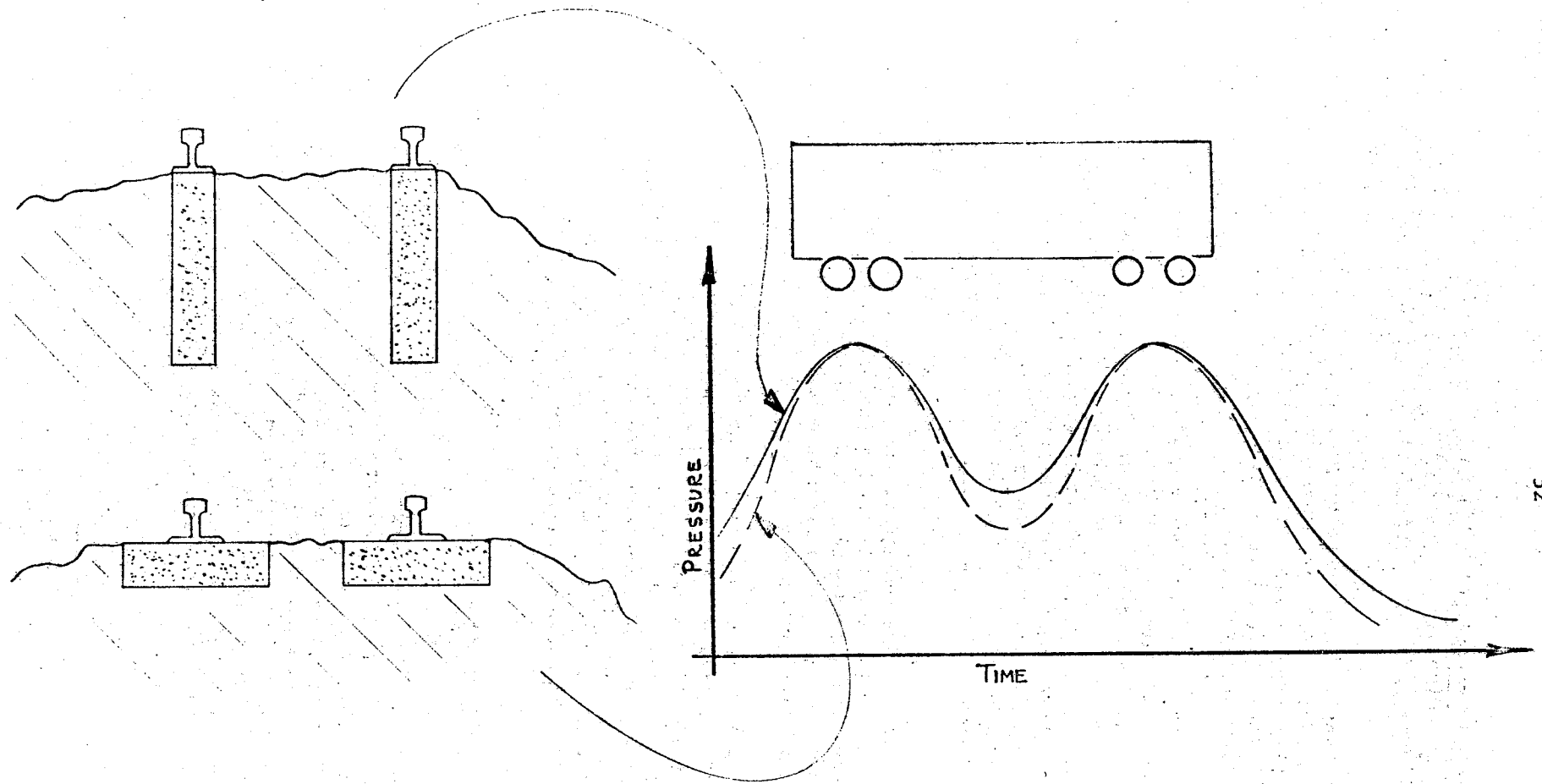

FIGURE 23 . TWO DIFFERENT TRACK STRUCTURES WHICH YIELD SIMILAR SOIL PRESSURE-TIME CURVES

### Approximate Pressure-Time Curve

The pressure-time curve can be closely approximated by:

$$p(t) \approx p_1 \cos 2\pi f_1 t + p_2 \cos 2\pi f_2 t + p_2 \quad (5)$$

where

$$f_1 = 1/\tau_1$$

$$f_2 = 1/\tau_2.$$

$\tau_1$  and  $\tau_2$  are the periods of the two most important cycles, as shown in Figure 22, and are constants for a given wheel spacing and train speed.  $p_1$  and  $p_2$  are the amplitudes of these two pressure cycles and are constants (for a given track structure) chosen such that  $p(t)$  passes through points MT and BC in Figure 22.

This approximation contains the two most important frequencies in the pressure-time curve ( $f_1$  and  $f_2$ ) and their respective amplitudes  $p_1$  and  $p_2$ . The accuracy of this approximation is shown in Figure 24, which compares a typical pressure-time curve with its approximate curve. Greater accuracy could, of course, be obtained by increasing the number of terms in the expression.

### Approximate Settlement Rate

With the approximation of the pressure-time curve as described above, the total settlement of the soil becomes dependent only on the values of  $p_1$ ,  $p_2$ ,  $f_1$ , and  $f_2$ . Earlier it was mentioned that new track structures for high-speed use should be designed so that there is no soil pressure fluctuation for each wheel, so that both  $f_1$  and  $f_2$  would be below  $f_n$ , the natural frequency of the soil, for the Budd car traveling at 160 mph. Therefore, only the left half of the settlement rate curve of Figure 21 need be approximated in order to evaluate the effects of  $f_1$  and  $f_2$ .

The settlement rate curve can be approximated as:

$$s = (\mu - 1) (\text{pressure amplitude}) \quad (6)$$

where  $\mu$  = magnification factor for a single-degree-of-freedom system

$$= \frac{1}{1-r^2} \quad (\text{for zero damping})$$

$r$  = ratio of the forcing frequency to the natural frequency of the soil

$$= f/f_n.$$

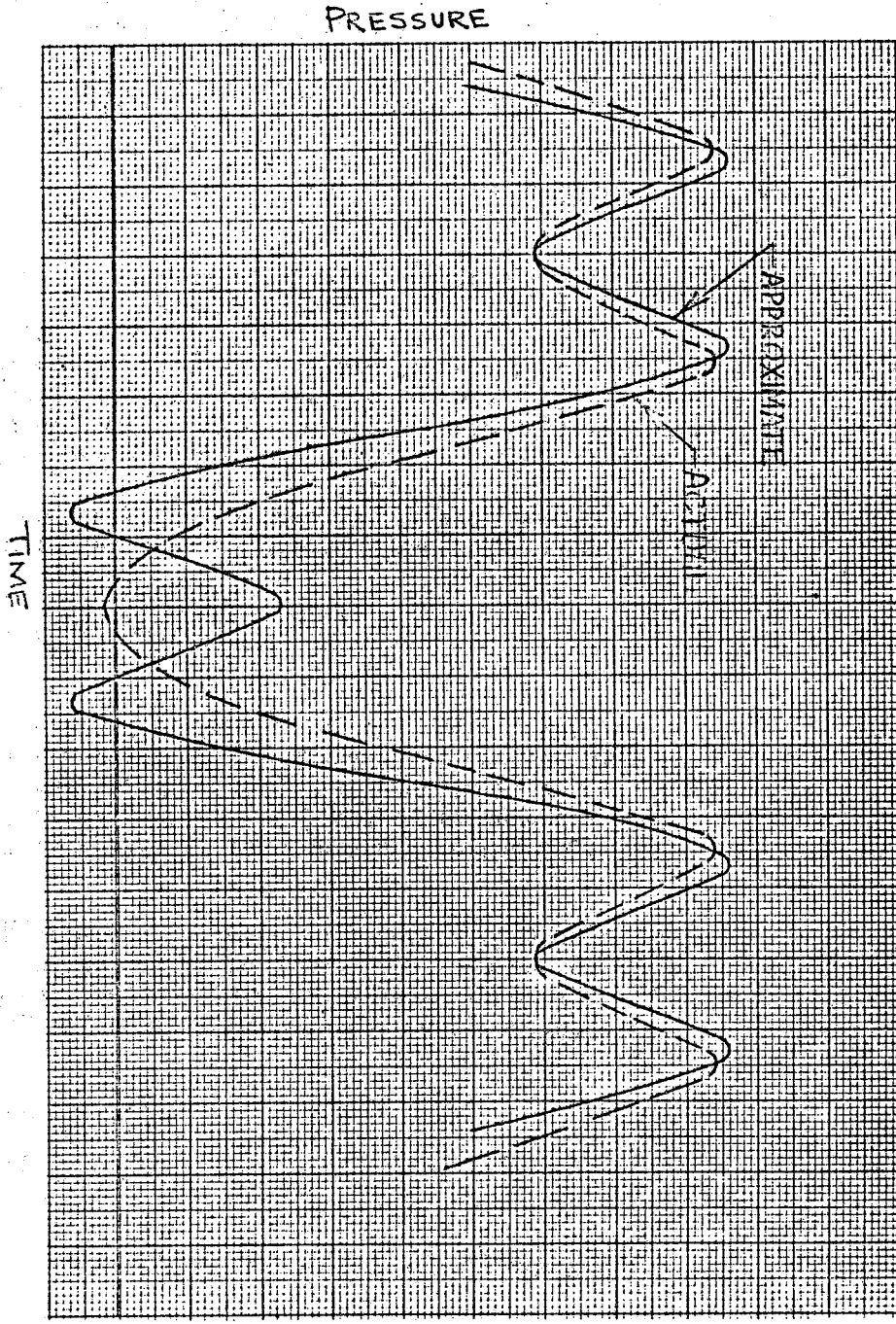

FIGURE 24. APPROXIMATE AND ACTUAL PRESSURE-TIME CURVE

For a pressure varying sinusoidally at one frequency (as shown in Figure 21),  $(\mu-1)$  can be calculated and thus the rate of settlement can be predicted.

The assumption of zero damping is not critical for values of forcing frequency that are less than about one-half of the natural frequency (which is the case in point), because the magnification factors for these frequencies do not change significantly with added damping.

With these two approximations, an estimate of the total effect of the time-varying pressure on the settlement of the soil can be made. This has been done, and a Soil Deterioration Factor (SDF) has been defined as the sum of settlement rates at the frequencies  $f_1$  and  $f_2$ .

$$\text{SDF} = s_1 + s_2 \quad (7)$$

$$\text{SDF} = |p_1| (\mu_1 - 1) + |p_2| (\mu_2 - 1) \quad (8)$$

$$\text{SDF} = |p_1| [r_1^2 / (1 - r_1^2)] + |p_2| [r_2^2 / (1 - r_2^2)] \quad (9)$$

This one number (SDF) can now be used to quantitatively compare the severity of the soil loading and, in turn, it can be used to compare two different track structures on the basis of soil loading. This method of comparison is especially useful in that it can be used to compare different track structures which carry different speed trains. For example, a track structure carrying a train at 160 mph can be designed to have the same amount of soil deterioration as a conventional track carrying the same train at 53.3 mph by equating the Soil Deterioration Factors based on the pressure-time curves for the two cases.

#### Reference System

To provide reference against which to compare advanced high-speed track structures, a conventional rail-tie-ballast track was chosen. To simplify the calculations and to obtain the least error in the approximations, the reference car and speed were chosen to be the Budd car traveling at 53.3 mph. One reason for using this speed as a reference was that at 53.3 mph,  $f_1 = 9.2$  cps, which is the same as that obtained with the Budd car at 160 mph under a structure rigid enough so that individual wheels do not cause individual pressure fluctuations. Also, this speed was believed to be one which well-built conventional track can withstand without requiring a large amount of maintenance.

A reference soil was chosen which has a natural frequency of 20 cps. It was believed that this value was a reasonably conservative value, and it was used for all calculations.

The pressure-time curve for this reference system was shown in Figure 18, and is approximated by Equation (5) where  $f_1$  and  $f_2$  are 9.2 cps and 3.07 cps, respectively. By setting



$$p(t_1) = 15.1 = p_1 \cos 2\pi (9.2) t_1 + p_2 \cos 2\pi (3.07) t_1 + p_2 \quad (10)$$

$$\text{and } p(t_2) = 10.4 = p_1 \cos 2\pi (9.2) t_2 + p_2 \cos 2\pi (3.07) t_2 + p_2 \quad (11)$$

and solving the two equations simultaneously, it is found that

$$p_1 = 4.20 \text{ psi}$$

$$\text{and } p_2 = 7.30 \text{ psi .}$$

The Soil Deterioration Factor can now be calculated as

$$\text{SDF} = 4.20 [(9.2/20)^2 / (1 - (9.2/20)^2)] + 7.30 [(3.07/20)^2 / (1 - (3.07/20)^2)]$$

$$\text{SDF} = 1.31.$$

This, then, is the value which was used as a reference, based on the specific case of the Budd car traveling over a conventional track structure at approximately 50 mph. Deterioration of the soil increases as the SDF becomes larger; advanced track structure designs were based on meeting or exceeding (lower SDF) this criterion at a train speed of 160 mph.

In general, the SDF depends on the pressure-time curve which, for a continuous beam-type structure, depends on the following:

- (1) The bending rigidity of the track structure (EI)
- (2) The width of the structure that rests on the soil (W)
- (3) The modulus of the soil ( $k_o$ )
- (4) The car weight
- (5) The wheel spacing of the car
- (6) The train speed.

The interrelationship of the first four of these factors is shown in Figure 25 for the Budd car's wheel spacing. Each curve represents the static pressure at a different point under the train-loaded track structure (or, for a particular train speed, each curve represents a different point on the pressure-time curve). A close examination of this curve is important. Note that for a given wheel load, and track structure width, each of the curves becomes a plot of soil pressure (proportional to deflection) versus soil stiffness per unit length and rail bending stiffness. A decrease in soil stiffness has the same

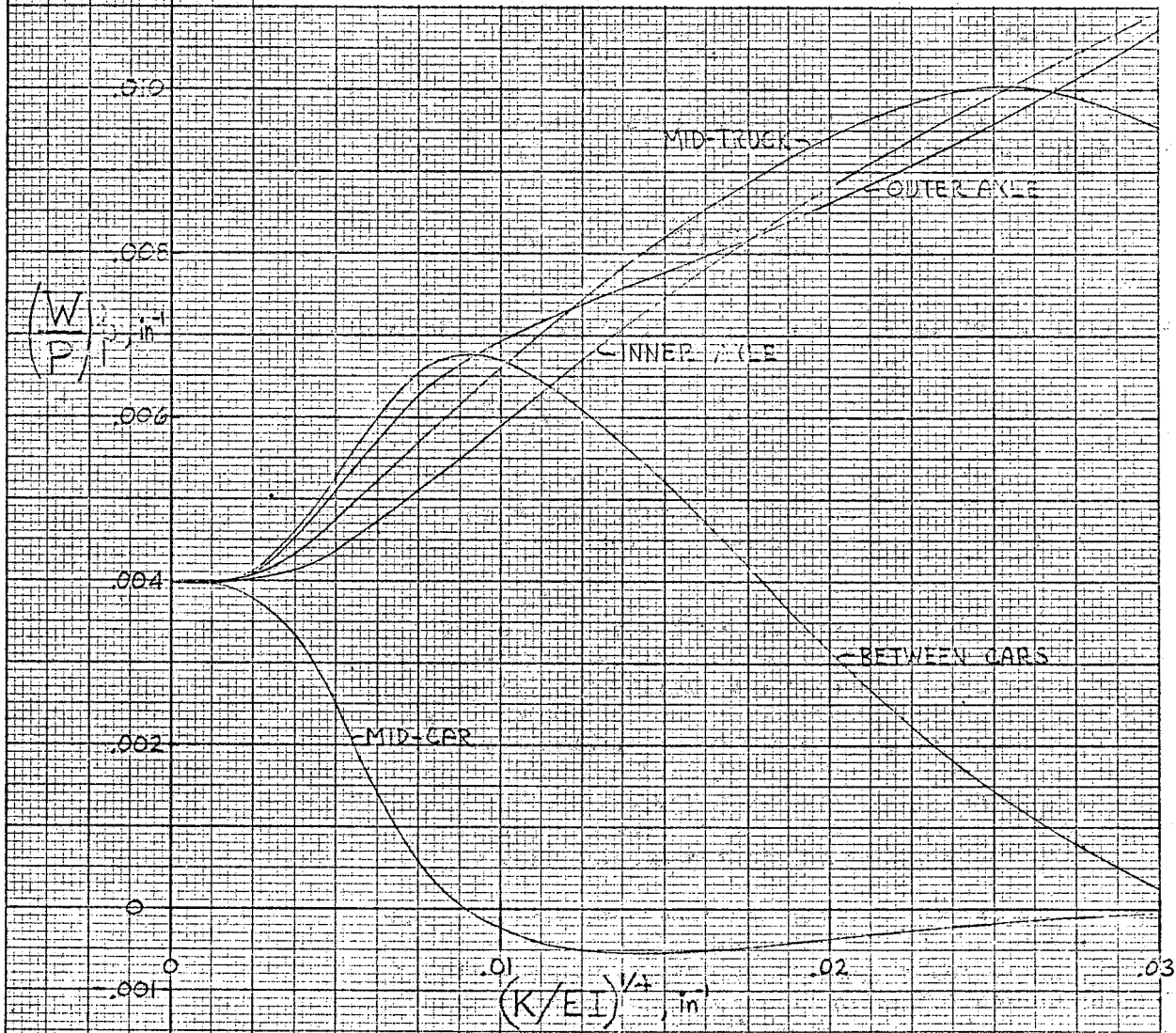
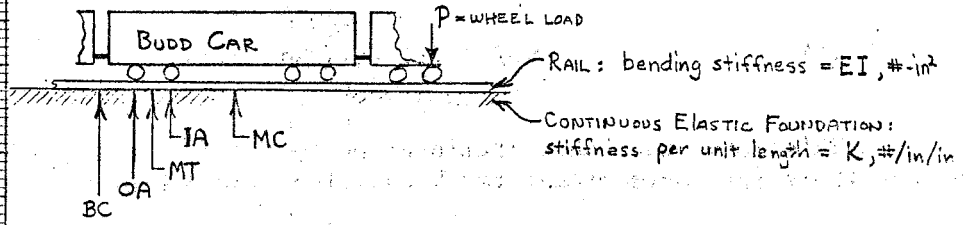

FIGURE 25. VARIATION OF STATIC SOIL PRESSURE UNDER DIFFERENT POINTS OF BUDD CAR WITH RELATIVE STIFFNESS OF RAIL AND ELASTIC FOUNDATION

effect as an increase in rail stiffness. To satisfy the criterion of seeing only one pressure pulse per truck, the portion of the curves to the left of  $(K/EI)^{1/4} = 0.025$  must be used. To the right of this point, the pressure at mid-truck (MT) drops below that at the wheels (IA and OA) meaning that two pressure pulses per truck would be generated, rather than one.

The design criterion, then, is composed of two restrictions which  $EI/k_o$  and  $W$  must meet:

$$(1) \quad SDF = f(EI/k_o, W) \leq 1.31.$$

This means that the deterioration to the soil will be no worse at 160 mph than it is for conventional track carrying a 53.3 mph train.

$$(2) \quad EI/k_o \text{ and } W$$

must be such that individual wheel pressures are not experienced by the soil. From Figure 25, if

$$(K/EI)^{1/4} \leq 0.022 \quad (12)$$

this requirement is conservatively satisfied, this reduces to

$$\frac{k_o W}{I_{\text{steel}}} \leq 7.3 \text{ lb/in.}^6 \quad (13)$$

These two restrictions on  $EI/k_o$  and  $W$  are shown in Figure 26. For points above the line, the criterion is satisfied; for points below the line it is not satisfied.

Points I, II, and III on the curve represent track structures (discussed in the next section) which satisfy the criterion, and point IV represents a track structure which does not satisfy the criterion because the point falls below the line. The pressure-time curves for these four track structures carrying the Budd car at 160 mph are shown in Figure 27. For these curves, a conservative value of  $k_o = 500 \text{ lb/in.}^3$  was used. (A conservative value of  $k_o$  is a relatively large one, because the pressure on the soil increases as  $k_o$  increases.) The pressure-time curve for conventional track carrying the Budd car at 53.3 mph shown in Figure 18 is repeated in Figure 27 for comparison purposes.

The structures represented by points I, II, and III have similar pressure-time curves because they all meet the criterion. Structure IV does not meet the criterion because of the high-frequency fluctuation caused by individual wheel pressures. This high frequency is expected to rapidly deteriorate the soil, causing the track to quickly lose its alignment.

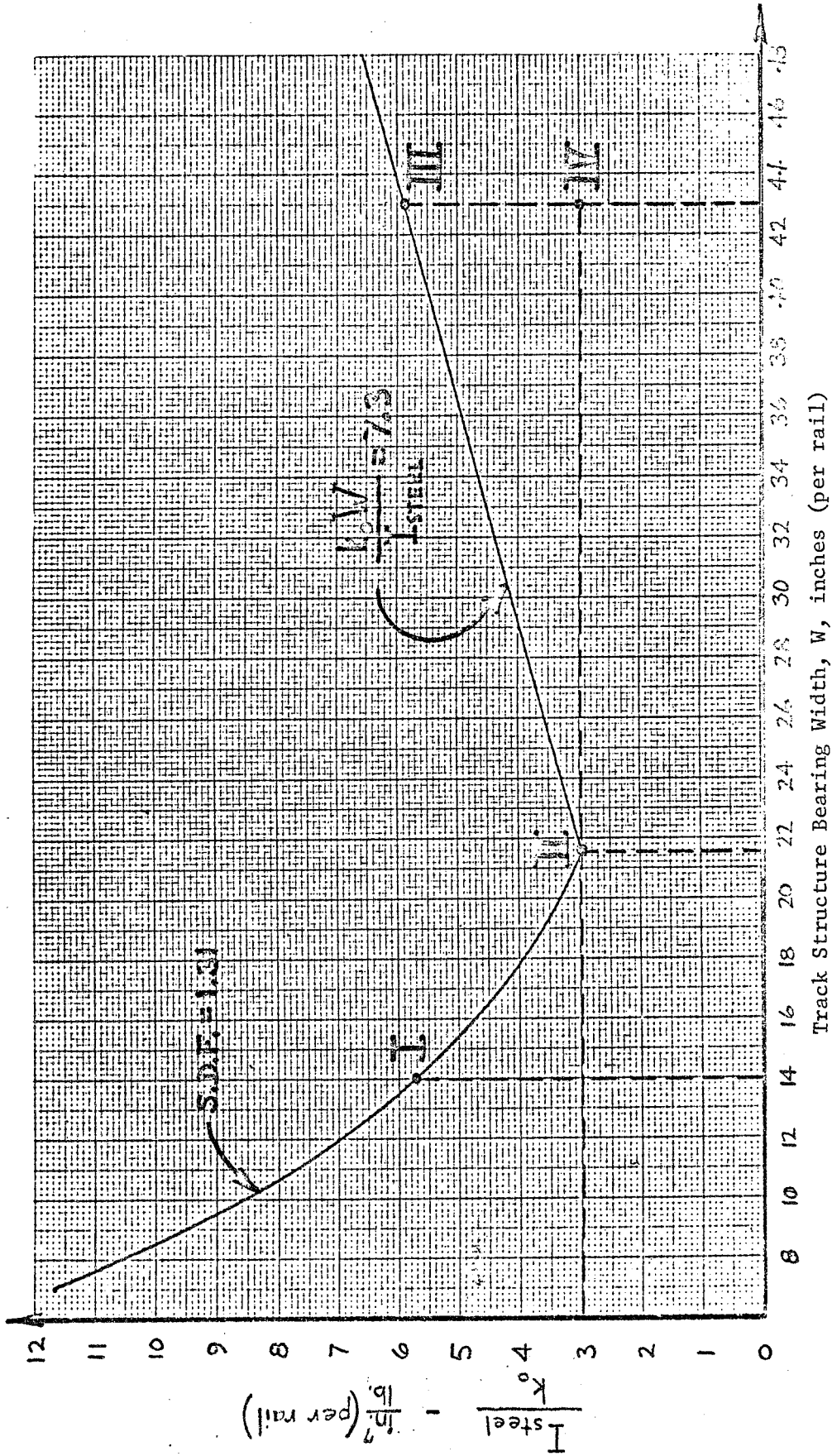
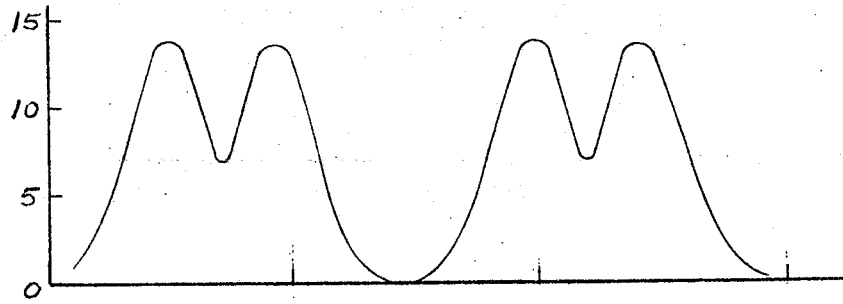

FIGURE 26. DESIGN CRITERION CURVE FOR SIZING TRACK STRUCTURE ON THE BASIS OF TIME-VARYING SOIL PRESSURE

I. (160 mph)

$$I_{\text{steel}} = 2850 \text{ in.}^4$$

$$W = 14 \text{ in./rail}$$



II. (160 mph)

$$I_{\text{steel}} = 1500 \text{ in.}^4$$

$$W = 21.5 \text{ in./rail}$$

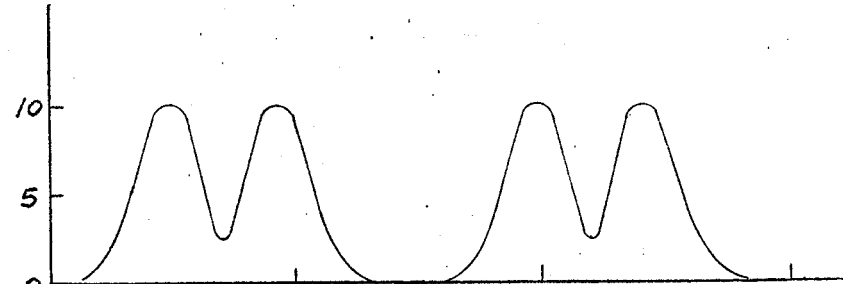

III. (160 mph)

$$I_{\text{steel}} = 2950 \text{ in.}^4$$

$$W = 43 \text{ in./rail}$$

(86-inch slab)

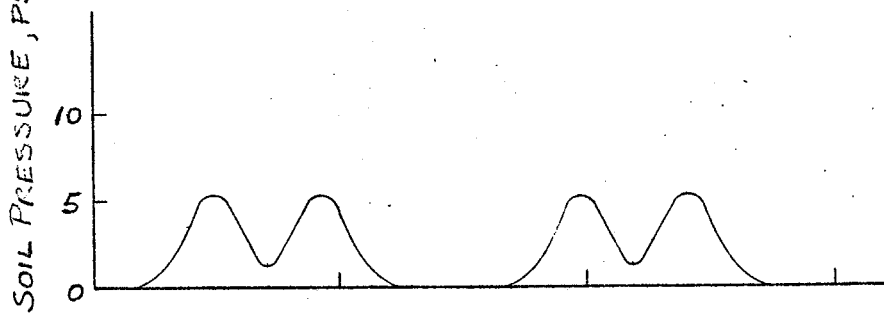

IV. (160 mph)

$$I_{\text{steel}} = 1500 \text{ in.}^4$$

$$W = 43 \text{ in./rail}$$

(86-inch slab)

CONVENTIONAL TRACK  
STRUCTURE (53.3 mph)(100 lb. rail,  
21 in. tie center-to-  
center spacing)

FIGURE 27. SOIL-PRESSURE-TIME CURVES FOR TRACK STRUCTURES OF DIFFERENT WIDTHS AND RIGIDITY (SOIL MODULUS,  $k_o = 500 \text{ LB/IN.}^3$ )

Thus, the curve of Figure 26 identifies almost all longitudinal beam-type track structures and classifies them on the basis of the design criterion. The structures represented by the line all meet the criterion of producing one soil pressure pulse per truck, and thus the final selection of an "optimum" track structure can be based on other considerations, such as cost.

### Preliminary Designs for Track Support Structure

The criterion described above establishes the required stiffness and width of a new high-speed track structure as a function of the settlement and deterioration of the soil or ballast.

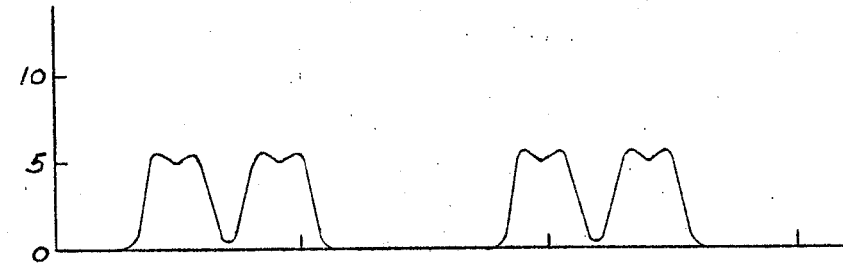
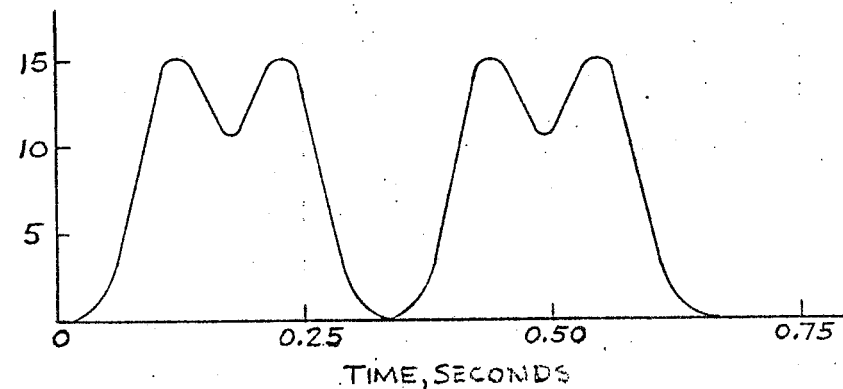
Examining the magnitudes of the required stiffnesses, as set by the criterion, it was evident that because of the insufficient stiffness of the rail itself, a continuous longitudinal structure would be required. It also appeared that the structure would have to be of fairly large size. For this reason only the materials which have predictable engineering properties and which are relatively inexpensive could be considered. The two materials that were considered to be best suited for this construction were concrete and steel. This section deals, therefore, with the possible types of construction available for building a superior track structure and with the factors which influence the costs.

Drawing 0001D (attached) shows some of the possible designs of longitudinal beam-type track structures which satisfy the design criterion, based on a soil having  $k_o = 500$  lb/cu in. This value for soil resilience would approximately represent the case for structures placed on existing roadbed of gravel or sand that has been well compacted by traffic. All of the track structures except 1b and 1c in the drawing are represented by point II on the design criterion curve of Figure 26. Beam No. 1b is represented by point I, and beam No. 1c by point III. However, note that all structures satisfy the design criterion. (The rail itself was not included in the calculations for these structures; this was done later in more refined designs, however.)

The beam can be classified into three groups: reinforced concrete beams, composite steel and concrete beams, and all-steel beams. Some of the considerations which led to the preliminary track structure designs shown in the drawing are discussed below.

#### Concrete Support Structures

For the anticipated loads and stresses developed by a fast-moving train the use of moderate-quality concrete was considered appropriate. By this is meant that the 28-day strength requirements would not exceed 3500 psi, with an elastic modulus on the order of 3-1/2 to 4 million psi. The additional necessary properties which would be required, such as fatigue resistance, impact resistance, and resistance to aggressive water and soils are well within the ordinary capabilities of concrete.

Precast Members. The concrete member used to support a rail member may be either precast or cast-in-place concrete. Precast members may be either of the reinforced or prestressed types, as discussed below.

The advantages of a precast member are many, in that a higher quality control of the material is possible, closer tolerances are permissible, and any necessary inserts or attachment devices may be incorporated into the members during fabrication. Precast members could also be inventoried and used whenever the need arises. This makes the application of precast members somewhat independent of field conditions and the weather. However, because of the anticipated stresses involved, reinforced sections would be preferable to prestressed members.

The disadvantages of precast members are also many, with the primary one being a higher inherent cost involved. By their very nature, precast members would be too stiff and heavy to install in long lengths. It would then be necessary to limit the length of members to something less than 60 feet. This would obviously result in a number of joints in field applications. These joints would then require some type of field connection to provide shear and/or moment transfer between the sections. This might present some difficulty in terms of the amount of field labor required to produce a continuous member from individual sections. Since the concrete supporting structure would be designed as a continuous elastic foundation, precast members would be at an immediate disadvantage because of the joining problem.

Cast-in-Place Members. Cast-in-place members, on the other hand, would appear to be well suited for the application where structural continuity is to be provided by the concrete. Because of the necessity for the supporting structure to withstand at least a minimal tensile stress, and because of the need for continuity in the member, reinforcing would appear to be an absolute necessity. Should cracks occur in an unreinforced section, the necessary continuity would be lost and there would be no provisions for field repairs which would reinstate the original integrity of the member.

A cast-in-place member may be fabricated either by using the slip-form method or by wet-casting the structure with removable forms. The technology of slip-casting has been sufficiently developed that a continuous supporting structure may be cast in the field with little or no difficulty. An advantage of the slip-form method is that the structure may be cast continuously using the subsoil as the supporting foundation, which would produce an excellent bearing interface. The reinforcing steel may be added during the slip-form casting procedure by reeling out precoiled reinforcing rods which have been butt-welded into a continuous reinforcing strand. The mechanical procedure for doing this would not present any insurmountable problems.

The principal disadvantages of the slip-form method are that the depth of section which can be cast is limited, and also there is the problem of incorporating attachment devices for the rail at the top of the structure. This would require either subsequent drilling and hand-placement of anchoring devices, or the development of a continuous rail-supporting media containing appropriate attachment devices which could be laid on top of the cast concrete member and vibrated into place. It is anticipated that this procedure would

involve a development program to develop the necessary procedures. The principal advantage of a slip-form casting procedure would be the relatively low cost involved. It is also anticipated that field maintenance procedures could be readily developed applicable to this system.

Cast-in-place members that are wet-cast may be somewhat more expensive than those made by the slip-form method because of the added labor involved in placing and removing forms. The relative ease by which the attachment device can be incorporated into a wet-cast member might balance this out, however. The cost of wet-cast members could be reduced by using reusable forms that are designed specifically for ease of handling. The forms could also be used as fixtures for holding and aligning studs or concrete anchors used in the attachment device during the casting operation.

Reinforced concrete beams derive their strength from the concrete and from the steel reinforcing bars, with the steel providing all the tensile strength. In this application, steel is required both on top of the section as well as on the bottom because of negative bending moments which will cause the top fibers of the beam to be in tension.

In view of these considerations, it was concluded that reinforced concrete would be required, and that the most applicable method of fabrication would be the cast-in-place method.

It was also considered that the complete spectrum of possible reinforced-concrete designs would be covered in the range having, at one extreme, a wide but relatively shallow slab, and at the other extreme two narrow but relatively deep beams.

For the preliminary designs of reinforced concrete track structures, then, structures at each extreme were considered (1b and 1c in Drawing 0001D), together with an intermediate design with two longitudinal beams somewhat deeper than their width. All three of these structures were designed to meet the design criterion, so that costs of structurally equivalent designs could be determined.

#### Composite Steel-Concrete Support Structures

Three preliminary designs of composite beams are shown in 2a, 2b, and 2c of Drawing 0001D. All of these designs meet the design criterion, and are represented by point II in Figure 26. Composite beams combine the relative advantages of both steel and concrete. In these beams, the steel provides almost the entire bending strength; however, to do this economically requires that the majority of the steel be located as far as possible from the neutral axis of the beam. This consideration indicates an I-beam or a wide-flange with a very narrow web, but a beam of this type would be very unstable due to buckling of the web and due to its poor torsional and lateral stiffness. Concrete is thus needed to provide the necessary stability and integrity.



In these composite beams, the concrete provides two other necessary functions. In all three designs it provides a good bearing interface between the beam and the soil, minimizing localized high bearing pressures. Also, the concrete provides good corrosion protection to the steel by completely surrounding it.

Studs are one method of providing a shear interface between the steel and the concrete, and may also be used to help locate and support the steel beams if the concrete is cast-in-place. The stud ends would not be exposed, thus alleviating the corrosion problem.

As with the all-concrete structures, the composite beams could be pre-cast or cast-in-place. It is assumed that, in either case, the steel beams would be welded together to provide good structural continuity. Therefore, even if precast members were used, some concrete would need to be field-cast to provide good bearing between the bottom of the beam and the soil and to cover the exposed steel at the welded joints.

#### All-Steel Support Structures

Figures 3a, 3b, and 3c in Drawing 0001D show preliminary designs of some "all-steel" support structures. Note that even with these, concrete would be desirable to provide good bearing on the soil except, of course, in elevated structures. Structures 3a and 3b would be of welded construction, and would have superior lateral and torsional stability when compared with 3c. The latter structure is the simplest imaginable, being one continuous rolled section such as a standard wide-flange beam. However, this beam would need to be constructed to be stable of itself by making the web sufficiently thick or the beam depth small or by providing web stiffeners at regular intervals along its length.

Cross bracing between the two beams would be required in all of these designs, and perhaps in the case of this beam (3c) it can also provide lateral and torsional stability to the beam.

Definite disadvantages to all-steel beams are their corrosion problems, and the problem of obtaining a good bearing interface between the beam and the soil. Adequate corrosion protection would be essential to a well-designed, long-lasting steel track structure. Any coatings used for this purpose would need to withstand the abrasive action caused by the relative motion between the beam and the soil or ballast under traffic. Also, the problem of keeping moisture (and, therefore, corrosion) out of the inside of the enclosed beams shown would require attention. As the beams would be welded together continuously, internal pressurization could exclude moisture at any tiny leaks at the welds.

Refinement of Reinforced  
Concrete Structure Designs

The design criterion already discussed has set a requirement on the bending rigidity of a longitudinal beam, and preliminary cost estimates indicated that concrete beams reinforced with steel deserved further investigation, since the least expensive structure was of this type, with all-steel structures being most expensive. There are, however, many reinforced concrete beams which will satisfy the design criterion. It is the object of this discussion to show how these were narrowed down to a few beams which would be superior to the other reinforced concrete beams on the basis of costs, yet equal in terms of strength.

The three reinforced concrete beams shown in Drawing 0001D represented initial ideas on what a beam that meets the soil pressure criterion might look like. These were sized on the basis of that criterion only, and were not designed on the basis of minimum cost. They appeared to be reasonable designs, however, and it was decided to pursue them further, and in particular to try to develop optimum designs on the basis of costs and stresses for beams that would also have an EI that satisfied the design criterion.

Two of the most important details of a reinforced concrete beam which greatly influence the overall cost and the stresses are the dimensions (the depth or height of the beam,  $h$ , and the width of the beam,  $W$ ) and the amount and location of the reinforcing steel. The most efficient reinforced concrete beam is a so-called balanced design, in which the stresses in the concrete and in the steel reinforcing bars are the same percentage of their allowable stresses. In other words, if the load on the beam were progressively increased, the concrete and steel would fail simultaneously. A balanced design thus makes maximum use of the strength of both of the materials and may result in some economy.

A balanced design may not, however, be the most economical design. This is particularly true when the beam is being designed on the basis of stiffness and not on the basis of strength. Other factors, such as the relative costs of concrete and steel, may make it more economical to use only a minimum amount of steel and make up for it by using more concrete; or, on the other hand, the labor costs involved in placing forms for concrete may be substantially higher than the labor costs for placing reinforcing bars, and this may result in a more economical design being one where steel is used in large quantities.

The beam required for the track support structure is one that must meet a minimum stiffness requirement as set by the design criterion, and for almost all of the beam designs considered this results in the stiffness and not the strength being the limiting factor. However, because of the potential economies available in using a balanced design, they were given considerable attention. Unbalanced designs were also considered and they were, at least, checked to see how far from being balanced they actually were.

Table 2 contains a summary of the types of reinforced concrete beams being considered, along with preliminary estimated costs for the beam structures. In the table,  $\gamma$  is the ratio of the maximum bending stress in the steel to the maximum compressive bending stress in the concrete, and thus indicates the

TABLE 2. PARAMETERS OF VARIOUS REINFORCED CONCRETE TRACK STRUCTURES

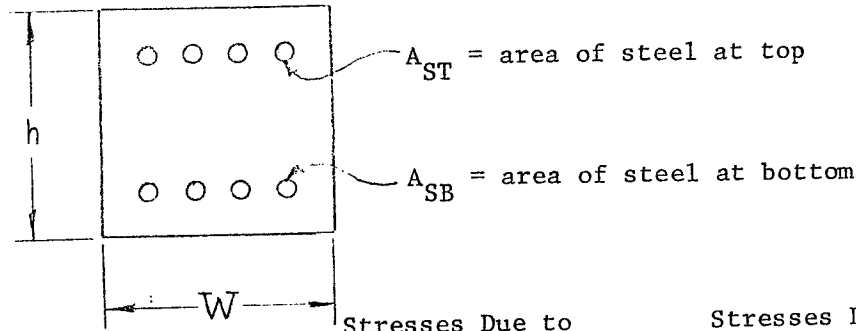

Beam Structure	$A_{sb,2}$ in.	$A_{st,2}$ in.	$A_{sb} + A_{st}$ in. <sup>2</sup>	h, in.	W, in.	$\lambda$	Stresses Due to Positive Bending, psi		Stresses Due to Negative Bending, psi		$\gamma$	Estimated Cost Per Mile of Track, thousands of \$
							Steel, tension	Concrete, compression	Steel, tension	Concrete, compression		
1	5.72	5.72	7.15	33.3	14.0	1/4	4,020	251	10,700	272	16	323
2	1.71	1.71	3.42	50.0	14.0	1	8,190	191	--	--	43	402
3	1.36	1.36	2.72	66.0	14.0	1	11,350	215	--	--	53	506
4	2.21	2.21	4.42	33.0	21.5	1	7,750	407	--	--	19	282
5	8.13	8.13	16.26	21.4	21.5	1	4,700	294	--	--	16	286
6	6.63	3.31	9.94	23.3	21.5	1/2	5,200	326	5,350	201	16	259
7	6.27	2.09	8.36	23.9	21.5	1/3	5,360	334	6,560	236	16	250
8	5.20	1.73	6.93	24.4	21.5	1/3	5,610	312	11,000	315	18	244
9	4.41	4.41	8.82	33.0	43.0	1	3,880	204	--	--	19	370
10	16.25	16.25	33.50	21.4	43.0	1	2,350	147	--	--	16	394
11	13.27	6.63	19.90	23.3	43.0	1/2	2,600	163	2,670	100	16	325
12	12.54	4.18	16.72	23.9	43.0	1/3	2,680	167	3,280	118	16	306

balance of the design. The allowable stress in the steel was considered to be 18,000 psi and that in the concrete to be 1,125 psi\* in compression, which results in a balanced design having an  $\gamma$  of  $18,000/1,125 = 16$ .

Considering all possible types of designs that meet the required EI, economically it might be appropriate to use stress levels that are as close to allowable stresses as possible. The bending stress,  $\sigma$ , is given by

$$\sigma = \frac{Md}{I} \quad (13)$$

where  $M$  = applied moment

$I$  = moment of inertia of the cross section

$d$  = distance from the neutral axis to the fiber at which the stress is desired.

For a given load and stiffness,  $M$  and  $I$  are constant and for high stresses to occur,  $d$  must be large. In general, a large  $d$  is obtained by using a very deep beam and this also allows the use of less steel to maintain the required stiffness. However, the savings in steel may be offset by the added costs associated with the greater depth beam, such as concrete costs, excavating or trenching costs, forming costs, etc. This is illustrated in Table 2 by comparing beam structures 2 and 3. As the height is increased from 50 to 66 inches the stress levels are increased and the amount of steel is decreased, but the estimated cost has increased. Thus it is not necessarily economical to have high stress levels.

On the other hand, a very shallow beam with low stress levels and with the large amount of steel needed to maintain the required stiffness, is not necessarily the most economical either. This can be seen by comparing structures 9 and 10 in the table. Thus, there is a relationship between the depth of the beam, the amount of steel required, and the total cost, so some optimum combination should exist.

Lower costs can also be realized by placing more steel at the bottom of the beam than at the top. The reason for this can be explained as follows. Figure 28a shows a typical beam cross section with equal amounts of steel at the top and bottom. If the concrete is considered to have compressive strength only (an assumption usually made in designing reinforced concrete beams) the neutral axis of the beam is located considerably above the centerline of the beam. To put more concrete to use in compression, the neutral axis can be moved down by having more steel at the bottom than at the top, as shown in Figure 28b. Thus, by utilizing more of the available concrete, the total amount of steel can be reduced while still maintaining the required stiffness.

---

\* Allowable unit stresses as specified by American Association of State Highway Officials (AASHO) for structural grade steel reinforcement and for concrete of density 150 pcf and 2800 psi 28-day strength.

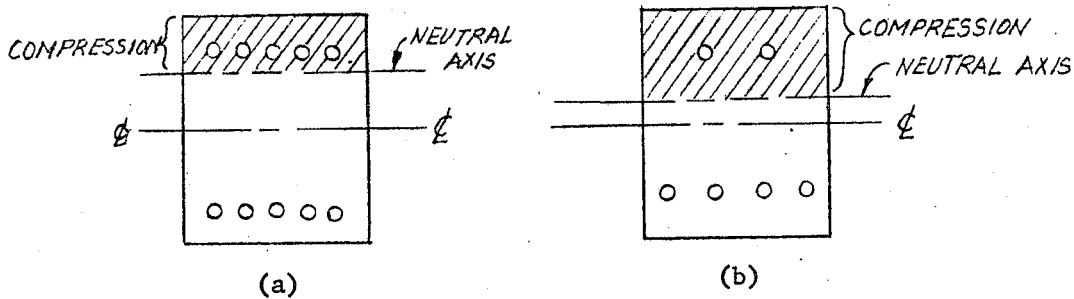

FIGURE 28. EFFECT OF DISTRIBUTION OF REINFORCING RODS ON POSITION OF NEUTRAL AXIS OF A CONCRETE BEAM IN BENDING

Structures 5, 6, and 7 in Table 2 clearly show how the total amount of steel and total costs can be reduced by placing more steel at the bottom than at the top. In the table,  $\lambda$  is the ratio of the amount of steel at the top to the amount of steel at the bottom. Substantial amounts of steel can be saved without much increase in the stresses. The slight differences in the height of the three beams was made to keep all three designs balanced and does not influence the costs appreciably. Structures 10, 11, and 12 are slab-type structures and show a similar pattern.

This savings in cost is not, however, obtained without sacrifice. By placing more steel at the bottom than at the top, the beam is no longer symmetrical about its centerline. This results in a lower EI in the negative bending direction (i.e., when the bottom of the beam is in compression and the top of the beam is in tension). Substantial negative bending moments do occur in the track structure, and the resultant stresses can be large because of this low EI in the negative direction. Structures 5, 6, and 7 show this increase in stresses for smaller  $\lambda$  due to this negative bending moment.

Possibly more important than the increased stresses is the reduction in bending stiffness of the beam itself. The equations for a beam on a continuous elastic foundation used in determining the design criterion presuppose that the beam has a constant EI along its entire length. Negative bending moments do occur along a significant portion of the beam and this results in a reduced EI in these regions. It is not accurately known to what extent the soil pressures will be increased by this and, therefore, the value of  $\lambda$  must be limited to some extent.

Sample calculations showing how the values in Table 2 have been determined for structure No. 6 are contained in Appendix B.

Selection of Final Reinforced  
Concrete Structure Designs

There are, as previously stated, a large variety of track structures that will satisfy the design criterion and will, from the standpoint of the soil, be equivalent. Once it has been decided that the structure must meet this criterion, the final selection of a structure must be made on the basis of strength considerations, economic considerations, and on other considerations that are more qualitative.

It has been shown that the strength of the structure is not a serious problem. The majority of the structures that meet the design criterion will also have sufficient strength.

Economic considerations have led to a somewhat restricted choice of materials. Concrete and steel are the only materials that could be considered in earnest for use in the structure, and as shown in the preceding section the judicious use of them is also required to keep costs to a minimum. Different methods of utilizing the concrete and steel to better advantage have been investigated: reinforced concrete structures, composite structures, and all-steel structures. The selection of a superior concrete-steel structure, however, had to be made on the basis of qualitative considerations. (All considerations, including qualitative ones are, of course, in the final analysis, economic in nature.)

Looking at all the factors, on the whole the reinforced concrete structure, cast-in-place, appears to be superior. A structure of this type would provide an excellent bearing interface between the structure and the sub-soil. The steel that is used is completely surrounded by concrete and thus prevents any corrosion problems. A wide variety of fastening devices and adjustment mechanisms can be incorporated into this type of design without any great difficulty. It would be a relatively simple matter to align that part of the attachment device that extends into the concrete to the required accuracy before casting the concrete. The required electrical characteristics for signaling and propulsion can also be obtained.

The designs of this type that appear attractive are structures 6 and 11 in Table 2, and are shown in Figures 1 and 3. The stress levels are only 29 percent of allowables and the overall dimensions are reasonable from the standpoint of using standard construction techniques. Structure 6 is composed of two longitudinal beams, joined together at intervals by cross-beams, while structure 11 is a slab-type structure. The choice between these two basic types of reinforced concrete structures depends on the balance between costs associated with the lateral beams in the one and the extra concrete in the other (slab) structure. Calculations (assuming 20-foot cross-tie spacing) indicated a considerable cost savings with the double-beam structure. Expansion joints are not considered necessary in the continuous concrete beams, as the relatively large amounts of reinforcing steel used will prevent small cracks from expanding. This is consistent with latest practice in highway construction.

### Control of Soil Moisture

In the final analysis, the track structure must transmit all loads into the earth, and the stability of the track structure will depend on the properties of supporting soil, or subgrade beneath it.

The use of the design criterion minimizes the applied soil loads. The other important factor is, of course, to maximize the allowable loads or pressures which can be withstood by the soil. It is believed that the single most important way to do this is to control the moisture in the soil, or subgrade, beneath the track structure.

It is interesting to note the variation in soil properties, both as a function of the soil type and as a function of moisture, as shown in Table 3. Therefore, proper drainage of railway roadbeds is a most important factor in achieving a stable track structure which minimizes the effects of weather and traffic. Excess water in the soil subgrade may produce deleterious performance of the roadbed in several ways. Tremendous pore water pressures develop in saturated or partially saturated soils under dynamic loading. These pore pressures reduce the internal friction of the soil mass, thereby lowering its shear strength. Likewise, a saturated soil is subject to the buoyant effect of water, which reduces the density and subsequently the contact pressure between the individual particles. Again, the effect is loss of shear strength.

When the clay content of the soil is significantly high, volume changes occur when water is added or removed. Differential heaving and settling are produced as the soil moisture content varies, usually as a periodic function of the seasonal precipitation distribution. Frost heaving is another cause of differential movement and is also directly related to the soil-water environment.

A saturated silt is very unstable and may be liquefied by impact or vibratory loading, with a complete loss of bearing capacity and shear strength. A loosely packed saturated sand is also subject to liquefaction. Under the dynamic action of traffic a wet soil may be churned into a viscous morass which will push outward and upward into the ballast, thereby reducing or destroying the interlocking action of the aggregate.

In view of these detrimental effects, it is obvious that the presence of moisture around the track structure must somehow be controlled. Moisture enters the ground by several avenues--the most obvious of which is infiltration of rain and snow. In low areas water may move in over the surface of the ground. Water also moves in under the surface by capillary action and other means.

The approximate depth at which water can be found is given by the water table depth. The true ground water table is stable from day-to-day, but varies slightly from season-to-season. The "perched" water table is also important. A perched water table results when water enters the soil faster than the soil is able to transmit it downward to the true ground water table. Often a cup-shaped impervious soil strata creates a basin which may accumulate a small quantity of water and retain it for long periods of time. This condition is most severe in the spring of the year when rainfall is high. This is

TABLE 3. SOIL CHARACTERISTICS

Major Divisions		Name	Drainage Characteristics	Unit Dry Weight, lb/ft <sup>3</sup>	Typical Design Values Subgrade Modulus k, lb/in. <sup>30</sup>
Coarse-grained soils	Gravel and Gravelly Soils	Well-graded gravels or gravel-sand mixtures, little or no fines	Excellent	125-140	300-500
		Poorly graded gravels or gravel-sand mixtures, little or no fines	Excellent	110-140	300-500
		Silty gravels, gravel-sand-silt mixtures	Fair to Poor	125-145	300-500*
			Poor to Practically Impervious	115-135	200-500
	Clayey gravels, gravel-sand-clay mixtures	Poor to Practically Impervious	130-145	200-500	
	Sand and Sandy Soils	Well-graded sands or gravelly sands, little or no fines	Excellent	110-130	200-400
		Poorly graded sands or gravelly sands, little or no fines	Excellent	105-135	150-400
		Silty sands, sand-silt mixtures	Fair to Poor	120-135	150-400*
			Fair to Practically Impervious	100-130	100-300
	Clayey sands, sand-clay mixtures	Poor to Practically Impervious	100-130	100-300	
Fine-grained soils	Silts and Clays**	Inorganic silts and very fine sands, rock flour, silty or clayey fine sands or clayey silts with slight plasticity	Fair to Poor	90-130	100-200
		Inorganic clays of low to medium plasticity, gravelly clays, sandy clays, silty clays, lean clays	Practically Impervious	90-130	50-150
		Organic silts and organic silt clays of low plasticity	Poor	90-105	50-100
	Silts and Clays***	Inorganic silts, micaceous or diatomaceous fine sandy or silty soils, elastic silts	Fair to Poor	80-105	50-100
		Inorganic clays of high plasticity, fat clays	Practically Impervious	90-115	50-150
		Organic clays of medium to high plasticity, organic salts	Practically Impervious	80-110	25-100

\*Close control of moisture.

\*\*LL less than 50.

\*\*\*LL greater than 50.



not a problem in sandy and silty soils, provided they are not underlain by a less pervious clay strata.

The ground water table is an important reservoir which can supply moisture to overlying soils by capillary action or vapor transfer. The height of capillary rise is a function of the particle size of the soil, and this moisture is not drainable. However, lowering the water table also lowers the zone of capillary water immediately above the water table interface (the so-called capillary fringe); that is, the height of the capillary fringe is not reduced but moved to a lower elevation.

Most subgrade materials cannot be relied upon to remove more than minor amounts of water unless specifically designed to do so. Because natural drainage of many soils is exceedingly slow and since it is impractical to prevent all influx of water, artificial means must be used to remove excessive water in a more rapid and expedient manner.

Two basic drainage types, surface and subsurface, are available to solve the common excess water problem. Both have advantages and limitations and require sound design and construction procedures to realize the maximum benefit in water control. The design of a specific drainage system requires consideration of many environmental and geologic factors peculiar to each location. Specific design details for both surface and subsurface drains may be found in several excellent references<sup>(12-14)</sup>. However, some important factors relative to the specific problem of railway roadbeds should not be overlooked. Surface drainage ditches have long been used to remove surface waters--thus preventing their movement into the subgrade. It is of prime importance to avoid the accumulation of these waters in depressions and low-lying areas by control of grade and provision for adequate outlets. The drainage system provided must handle the large volume of surface water often produced by severe storms, and should remove the water from the roadbed area as rapidly as possible, while still allowing disposal in a manner which is not detrimental to adjacent land.

In addition to surface drainage, subsurface drainage is needed if moisture conditions below the surface are to be controlled. The removal of water internal to the soil mass generally is done by using subsurface drains made from clay or concrete tile. In low-lying areas and adjacent to rivers and canals the ground water level is often near ground elevation, and must be lowered by subsurface drains. Lowering the water table below the frost line is also a means of controlling frost heaving, which develops when water is transferred to the freezing zone by capillary action.

In elevated areas in which surface drainage is good, seepage waters often present serious problems, and are a major cause of slope failures. Water moving under hydrostatic head induces soil failure by reducing interparticle friction and sometimes actually suspending and transporting soil particles, thereby creating voids in the soil mass. Such problems are local in nature and are most troublesome in deep cuts and hillsides. Seepage of water from springs and nearby high ground may actually produce a hydrostatic head capable of producing uplift and failure of the roadbed.

Some Specific Drainage Structures

The discussion above emphasized the importance of drainage of the soil subgrade to achieve stability and maintain soil strength. While the specific details of drainage structure design must be tailored to actual soil conditions in the field, the geometric features of drainage systems will be fairly constant. Surface drainage techniques have been employed by railroads for many decades, but are not necessarily effective in controlling subgrade moisture content. Reduction of soil moisture content is best achieved by subsurface drainage techniques, and the following discussion is confined to subsurface drainage techniques.

In conventional track systems, open-graded rock or ballast is placed directly on the soil subgrade. However, ballast is subjected to eventual clogging by dust and waterborne fine particles. The clogging reduces the drainage efficiency of the roadbed structure resulting in accumulation of water in the subgrade and, thus, loss of bearing capacity. This clogging may be prevented by constructing a transition "filter" layer between the ballast and subgrade.

The requirements of this filter layer would be (1) it must not clog the ballast, (2) it must not allow intrusion of adjacent soil, and (3) it must allow rapid removal of water; that is, it must be more pervious than the protected soil. When a filter layer is used in conjunction with a drain pipe or tile it must prevent movement of fine soil particles into the drain openings.

Embankments subject to inundation are often in a state of reduced stability when floods subside rapidly. When excess pore water pressures develop, the slope may fail by sliding. Inclusion of a filter under the fill will reduce the loss of stability by directing the seepage pressures downward toward the filter layer, instead of outward<sup>(15)</sup>.

Terzaghi<sup>(16)</sup> proposed a system for selection of filter material which has been tested and, with slight modification, adopted for general use in earthen dam and highway construction<sup>(17)</sup>. These criteria are:

To prevent clogging of the filter material

$$\frac{15 \text{ percent size of filter material}}{85 \text{ percent size of protected soil}} \leq 5$$

and

$$\frac{50 \text{ percent size of filter material}}{50 \text{ percent size of protected soil}} \leq 25$$

To achieve adequate drainage capacity

$$\frac{15 \text{ percent size of filter material}}{15 \text{ percent size of protected soil}} \geq 5$$

(Note: the percent size is obtained from a grain size distribution analysis expressed as percent finer by weight.)

Also, no material is to be so fine as to pass a No. 200 sieve; i.e., no clay. This method provides excellent resistance to clogging, but drainage capacity is somewhat limited. This is to be expected since these two factors are in opposition to each other. However, if the filter is sandwiched by the subgrade soil, as in an embankment, the limiting factor is the permeability of the soil. If greater drainage capacity is needed it is necessary to use a two-layer system: a coarse open drain layer protected by a filter layer. This decision must be based on actual soil permeability, hydraulic gradients, and intensity of soil moisture influx in the field.

The criteria for this selection is Darcy's Law<sup>(14)</sup>:

$$Q = Aq \frac{dH}{dx} t \quad (14)$$

where  $Q$  = volume of flow, in.<sup>3</sup>

$A$  = cross-sectional area, in.<sup>2</sup>

$q$  = hydraulic conductivity or coefficient of permeability, in./sec

$dH/dx$  = hydraulic head per unit length, in./in.

$t$  = time.

Hence, volume of flow in a filter layer of a given conductivity can be enhanced by increasing the gradient; i.e., sloping the filter toward the drainage outlet. Doubling the filter slope will double the amount of outflow for a given time but capacity will still be lower than the two-layer system.

The one-or-two-layer filter systems provide for drainage of the roadbed structure, but do not prevent horizontal or vertical seepage into the structure from the adjacent areas. Disposal of seepage waters is most economically accomplished by tile or perforated pipe underdrains placed in filter material. The tile or pipe can perform several functions. First, they provide the easiest method of lowering a high water table. Second, seepage is intercepted before it reaches the roadbed structure. Third, an outlet is provided for the subgrade filter.

Although selection of filter material can be based on past experience and testing, tile drainage system design may appear to be arbitrary. All that can be said for tile drainage is that it is desired to keep the subgrade as dry as possible. Since there is no known precedent to this application, the following system is recommended.

Drainage can be accomplished by placement of a drain under the middle of vegetated surface channel on both sides of the right-of-way. The minimum depth and slope are 3 feet deep and 0.1 percent slope downstream. Porous clay tiles should have minimum diameter of 4 inches. The tile should be backfilled with filter material and provide an outlet for subgrade filter systems. This is

a conservative design but one of necessity to maximize the stability for long periods of time.

Figures 29a and 29b show recommended means for controlling the moisture beneath the track structure. The two-tile drainage systems are preferred but are, of course, more expensive than single-tile systems. Plastic can be used as shown to intercept water percolating downward from the ballast, but must be protected from puncture by a drain or filter layer, which also serves to carry away water entering from the top.

Figure 30 shows how the method shown in Figure 29b might look when applied to a specific track structure. In conclusion, the degree to which moisture can be controlled depends on the amount of money available for this purpose. The use of a continuous-beam track structure will give a structure which is much less affected by changes in moisture than conventional track, and a balance between costs and benefits will determine the extent to which moisture should be controlled.

#### Analysis of Resilience of Track Structures

The question of how much, if any, resilience is desirable in a track structure was one given serious attention during this project. In particular, the advantages of resilience between the rail and the supporting structure (such as might be provided by a rubber pad beneath the rail) were investigated. At the outset, there appeared to be two advantages to introducing resilience between the rail and the beam structure beneath. It seemed plausible that a resilient pad would, in the static case, distribute the wheel load over a larger area of the beam structure and thus would reduce deflections and stresses in the structure, giving lower bearing pressures on the soil. In the dynamic case, it seemed logical that resilience would decrease the wheel-rail force due to wheel or rail profile error by allowing the rail to deflect more, resulting in less dynamic profile error. This would add to ride comfort and would lower stress levels in the track structure and the truck components because of the reduced wheel-rail forces.

In order to judge the validity of these initial beliefs, two investigations were undertaken. To determine the advantages of resilience in the static case a short digital computer program was run, and to determine the advantages of resilience in the dynamic case, an analog computer simulation of the car and track system was undertaken.

#### Digital Computer Program for Static Deflections

With no resilient pad between the rail and the structure, the track and its supporting structure can be defined mathematically by the equations for a single beam on a continuous elastic support (the soil), as discussed in a previous section of this report. When a resilient element is introduced between the rail and the beam structure, the equations that define the system become

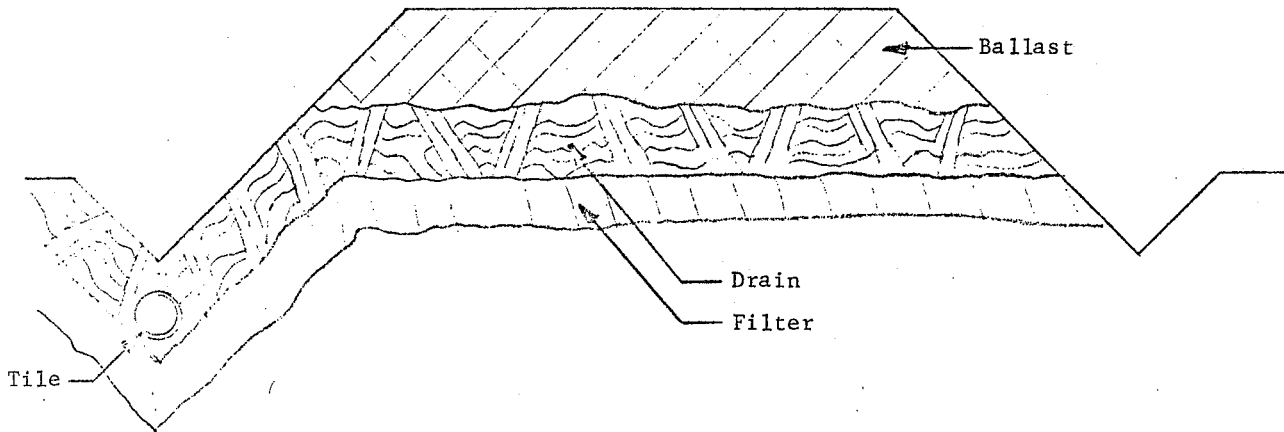

(a). One Tile Drain

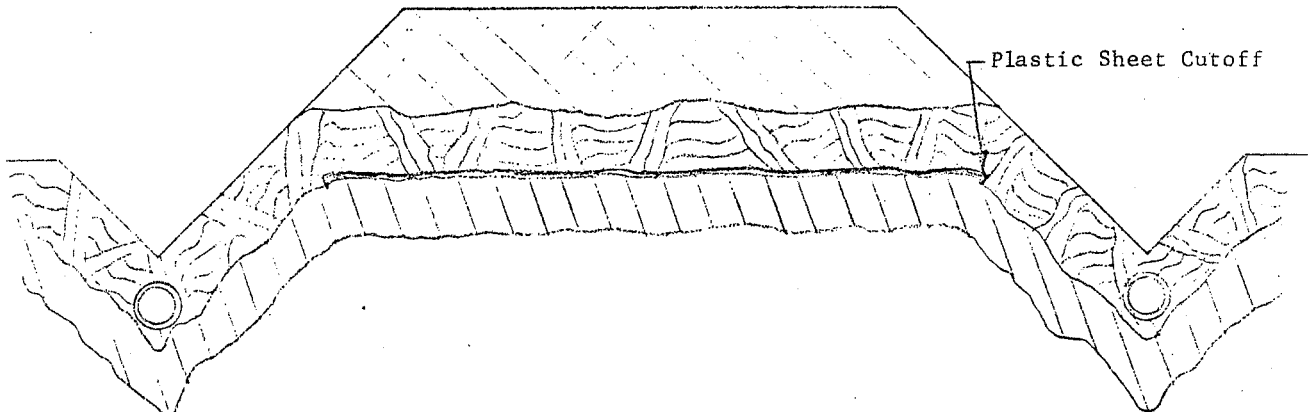

Note: Drain and filter layer must protect plastic from puncture

(b). Two Tile Drain

FIGURE 29. DRAINAGE STRUCTURE

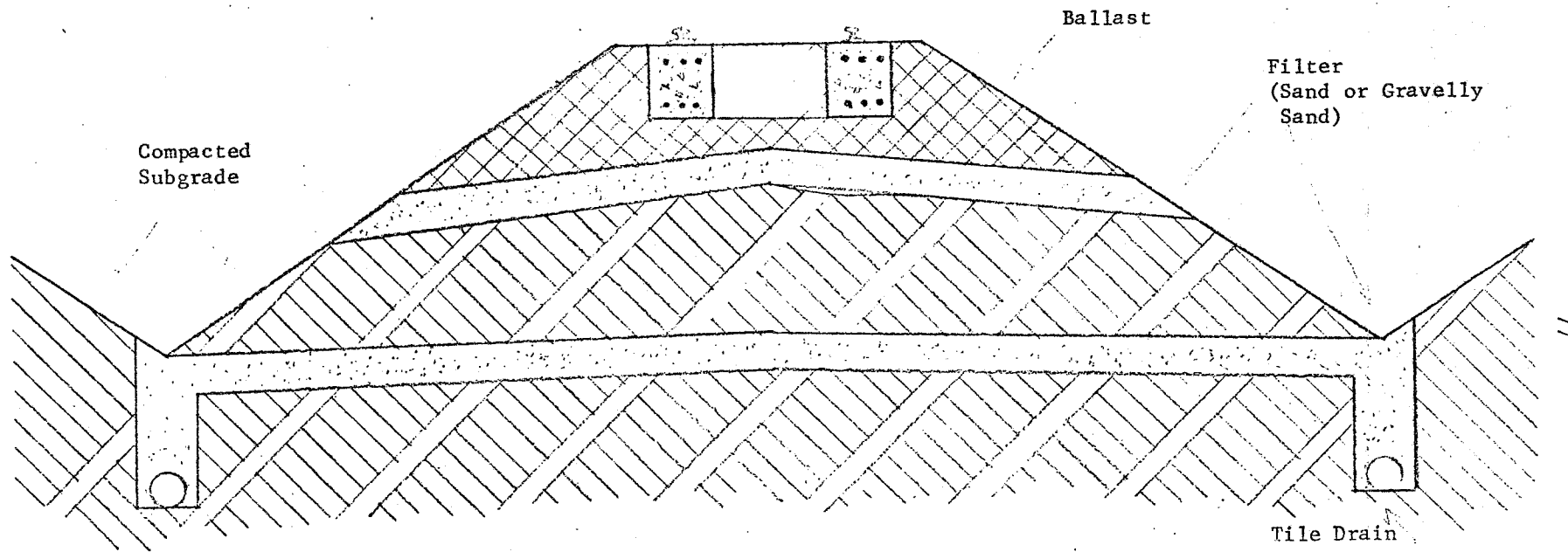

FIGURE 30. PROPOSED EARTHWORK BASE FOR TRACK STRUCTURE

much longer and more complex, as shown in Reference (18). This, together with the fact that the pressure on the soil, and the stresses in the structure, at any point are the result of superimposing a number of wheel loads at various distances from the point of interest, made it economical to use the digital computer to evaluate the effects of a resilient rail pad.

A short digital computer program was written to enable the effects of resilient rail pads to be evaluated quickly. The computer calculated the overall stiffness at the rail head and the pressure on the soil at various locations with respect to the applied load for different values of rail rigidity, pad resilience, supporting-beam rigidity, and soil resilience. It was anticipated that suitable combinations of these four parameters could be found which would ensure track structure designs that had the desired overall stiffness and which would also meet the design criterion based on the time-varying pressure on the soil, as discussed previously. The bending moment in the rail and in the beam also were calculated so that the track structures could be checked on the basis of strength. The input to the program consisted of values for the following system variables:

- (1) Flexural rigidity of the rail,  $EI_R$ , lb-in.<sup>2</sup>
- (2) Stiffness of the rubber pad per unit length,  $K_p$ , lb/in.<sup>2</sup>
- (3) Flexural rigidity of the beam structure,  $EI_B$ , lb-in.<sup>2</sup>
- (4) Stiffness of the soil per unit bearing area,  $k_o$ , lb/in.<sup>3</sup>
- (5) The distance from a reference point to the stations along the length of the track at which the output quantities were desired,  $x$ , in.

The outputs of the program consisted of values for the following quantities at the various desired points,  $x$ , along the track:

- (1) Deflection of the rail,  $y_R$
- (2) Deflection of the beam structure (from which soil-bearing pressure was obtained),  $y_B$
- (3) Bending moment in the rail,  $M_R$
- (4) Bending moment in the beam structure,  $M_B$ .

Figure 31 shows a typical track system and a plot of some of the computed results (Run 2) for the system. The deflections of the rail and the beam structure that are plotted are the result of the loads from the four wheels shown. Loads from wheels further down the track are a sufficient distance away that their contribution to the total deflection is negligible. Note that with this very soft pad, the rail deflections are six times those of the support structure.

A number of computer runs for different track systems were made to evaluate the effects of a resilient rail pad, and a summary of the important results is shown in Table 4. Contrary to expectations, the data for run

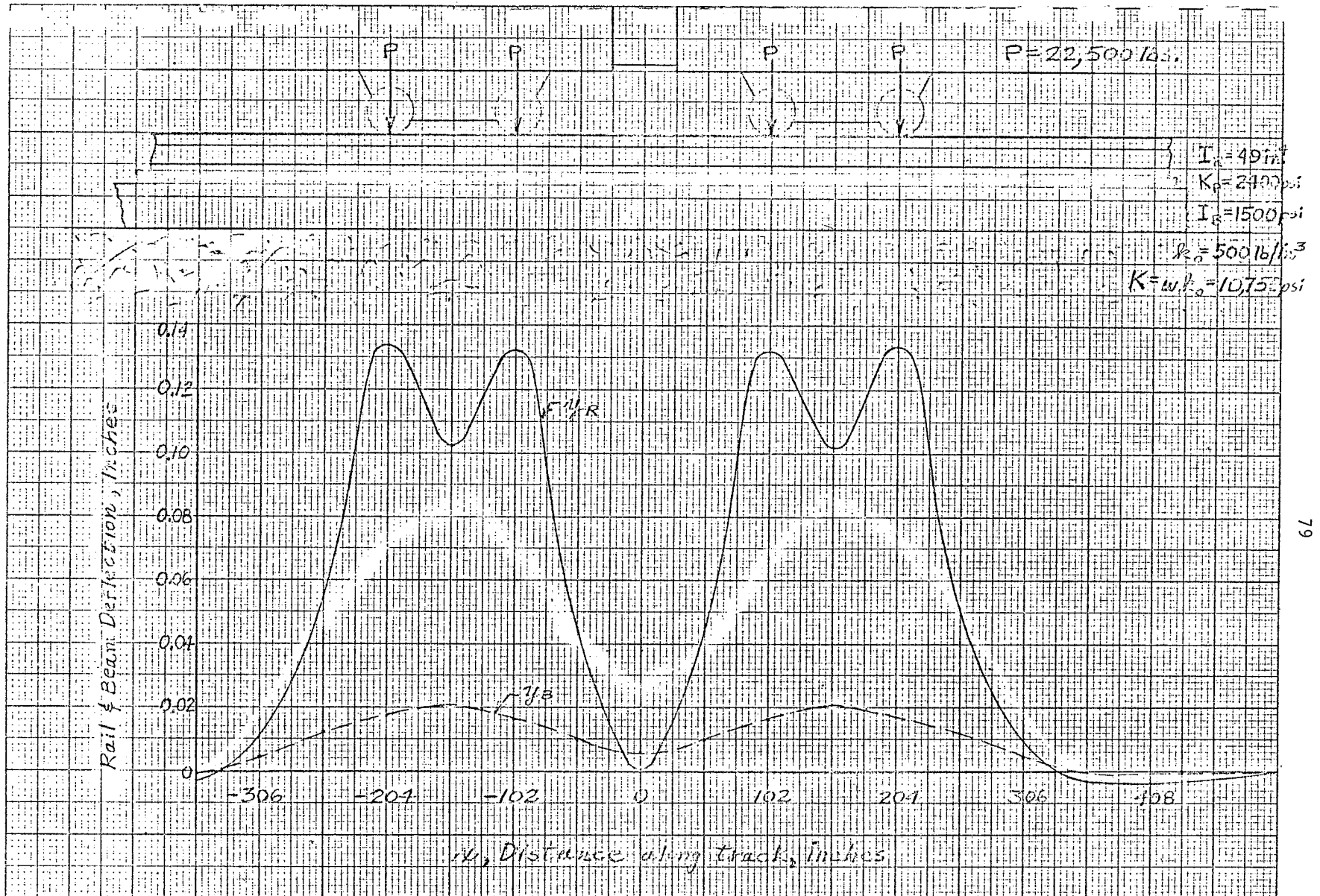

FIGURE 31. STATIC DEFLECTIONS CALCULATED BY DIGITAL COMPUTER PROGRAM INCLUDING EFFECTS OF RESILIENT PAD



TABLE 4. RESULTS OF DIGITAL COMPUTER PROGRAM

Digital Computer Run No.	$I_R,$ in. <sup>4</sup>	$K_{\text{Pad}},$ lb/in. <sup>2</sup>	$I_B^*,$ in. <sup>4</sup>	$k_o,$ lb/in. <sup>3</sup>	$Wk_o = K,$ lb/in. <sup>2</sup>	$M_R,$ Maximum Positive Bending Moment in Rail x 10 <sup>-5</sup> , in.-lb	$M_B,$ Maximum Positive Bending Moment in Beam x 10 <sup>-5</sup> , in.-lb	$y_B,$ Maximum Deflection of Beam, in.	$p = k_o y_B,$ Maximum Soil Pressure, psi	Overall Stiffness at Rail x 10 <sup>-5</sup> , lb/in.
1	49.0	2,400	2,850	500	7,000	2.26	2.59	0.0278	13.90	1.66
2	49.0	2,400	1,500	500	10,750	2.27	1.59	0.0209	10.45	1.71
3	49.0	5,000	1,500	500	10,750	1.90	1.85	0.0209	10.45	2.72
4	95.6	5,000	1,500	500	10,750	2.27	1.60	0.0207	10.35	3.15
5	49.0	24,000	1,500	500	10,750	1.32	2.34	0.0207	10.35	6.15
6	49.0	24,000	1,500	100	2,150	1.37	4.06	0.0843	8.43	3.02
7	49.0	24,000	3,000	500	21,500	0.748	2.87	0.0102	5.10	19.00
8	49.0	24,000	3,000	100	4,300	1.31	4.10	0.0422	4.22	4.70
9	49.0	72,000	1,500	100	2,150	1.09	4.35	0.0842	8.42	3.56
10	49.0	$180 \times 10^6$	1,500	500	10,750	0.244	3.38	0.0204	10.20	13.80
11	49.0	$180 \times 10^6$	1,500	100	2,150	0.301	5.12	0.0841	8.41	5.15
12	0.1	$180 \times 10^6$	2,230	500	10,750	0.029	3.94	0.0197	9.85	15.10
13	0.1	$180 \times 10^6$	2,230	100	2,150	0.029	5.91	0.0801	8.01	4.53

\* The values for  $I_B$  are for an equivalent all-steel beam ( $E = 30 \times 10^6$  psi).

Nos. 2, 3, 5, and 10 show that the soil pressure is virtually unaffected by changes in the stiffness of the pad in the practical range of resilience investigated.

However, the maximum bending moment in the rail and in the structure is significantly affected by the use of a resilient pad. The bending moment in the rail and in the beam for run Nos. 2, 3, 5, and 10 are plotted in Figure 32, and show the effects of changing pad stiffness for a particular rail, beam structure, and soil stiffness. As shown in the curves, the bending moment in the rail decreases and the bending moment in the beam structure increases as the pad stiffness increases.

Another parameter that changes appreciably with changes in pad stiffness is the overall stiffness of the track system at the rail head. This change influences the dynamic response of the car and track, and will be discussed in the next section which deals with the analog simulation.

The condition of the soil also has an effect on the various parameters, as can be seen by comparing computer run Nos. 5 to 6, 7 to 8, and 10 to 11 in Table 4. In general, the pressure on the soil decreases as the stiffness of the soil (modulus of subgrade reaction-- $k_o$ ) decreases. At first glance it would appear that a more resilient soil is desirable because of the lower bearing pressures; however, this is not true. More resilient soils generally have lower bearing strengths and, in fact, the allowable bearing pressure of a soil is approximately proportional to its modulus of subgrade reaction ( $k_o$ ). This means that a soil having a  $k_o$  of 500 lb/in.<sup>3</sup> can withstand about five times the bearing pressure than can a soil having a  $k_o$  of 100 lb/in.<sup>3</sup> Since the range of bearing pressures calculated is less than 5 to 1, the soil having  $k_o$  of 500 lb/in.<sup>3</sup> is actually loaded less severely than the soil having a  $k_o$  of 100 lb/in.<sup>3</sup>.

Conclusions regarding the desirability of a resilient rail pad are given after the discussion of the analog simulation and the effects of the resilience on the dynamic characteristics of the track structure. However, from a static structural viewpoint, the main advantage of resilience was found to be that it decreased the bending moment (and, therefore, the stresses) in the rail support beams.

#### Analog Computer Simulation for Dynamic Response

The object of the analog computer work was to determine the most suitable value of track stiffness from a dynamic standpoint and, in particular, to determine the most desirable value for the stiffness of a resilient pad between the rail and the beam structure. If no resilient pad were used in the new track structure designs, the overall stiffness as seen by the wheel would be substantially greater than it is for conventional track, due to the large difference in the bending stiffness of the two types of structures; but it was not known what effect this would have on ride comfort, wheel-rail reactive forces, and soil bearing pressures. The simulation was made to evaluate these dynamic effects and to determine a suitable pad stiffness.

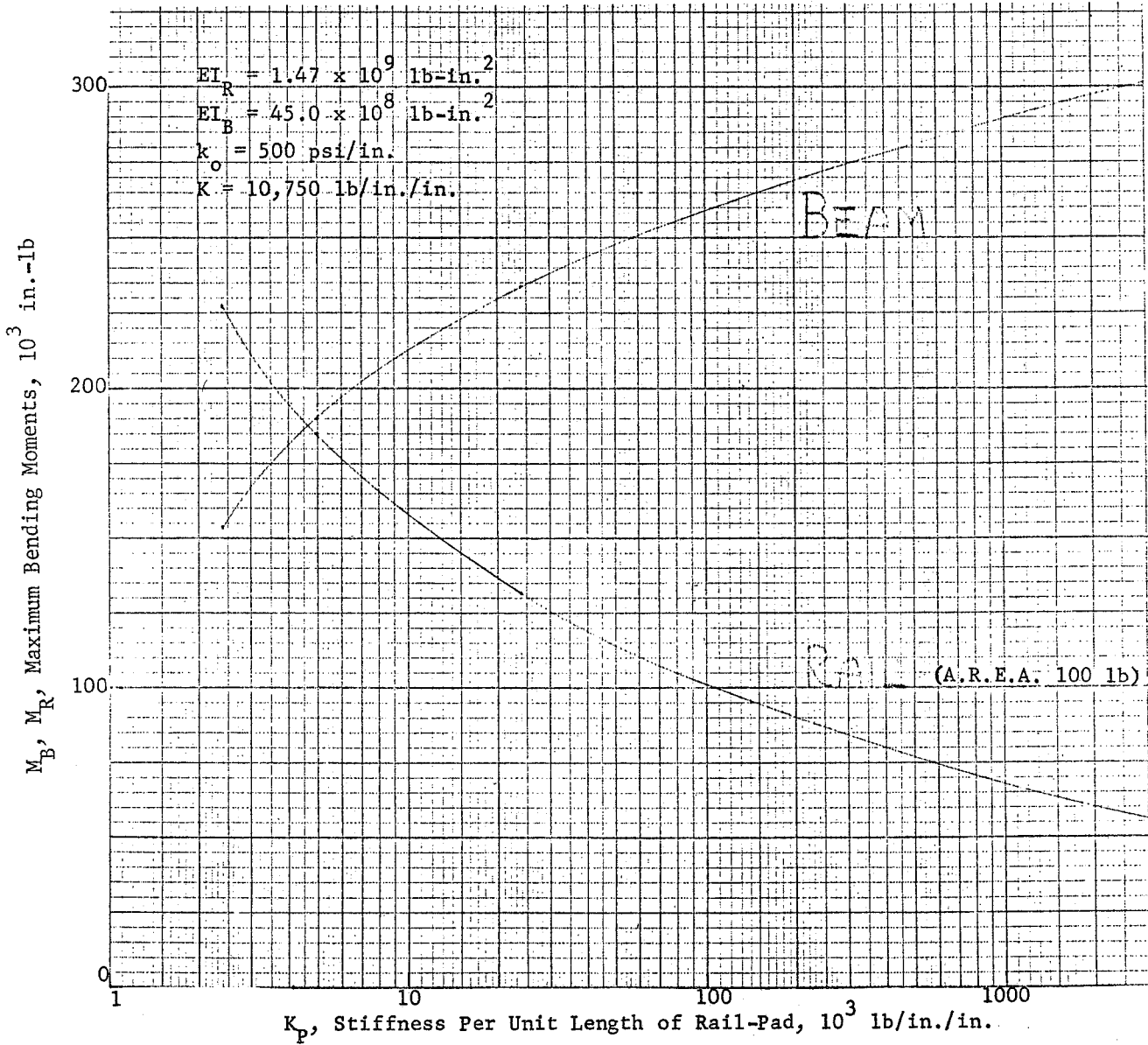

FIGURE 32. MAXIMUM BENDING MOMENT IN RAIL AND BEAM FOR DIFFERENT RAIL PADS

In order to simulate the system in question, the track structure and the car were represented mathematically. The simulation of the track structure involved the representation of an infinitely long, continuous structure by an equivalent lumped-parameter system composed of discrete masses, springs, and dampers. The simulation of the car involved a more straightforward approach in that each mass, spring, and damping element in the car was fairly accurately represented by an analogous element in the model.

Simulation of the Track Structure. The accepted theory for the vertical deflection of rails is based on the assumption that the rail can be considered as an elastic beam continuously supported by an elastic foundation. The static deflection of the rail is given by Equations (2), (3), and (4) of a previous section.

The deflection of the rail under traffic, however, is not a static problem. For one thing, the point of application of any wheel-load moves along the rail at the speed of the train, and for another, the magnitude of the force felt by the rail may be time-varying (due to dynamic unbalance in the wheels and/or surface irregularities such as flat spots on the wheels and joints in the rails).

The dynamic response of the rail to a single unbalanced wheel load moving at constant velocity,  $V$ , along a conventional track was investigated first by considering the two limiting cases of the problem, which are

- (1) The applied force is stationary ( $V = 0$ ) but the magnitude of the force is varying harmonically with time at some frequency,  $f$
- (2) The applied force has a constant magnitude, but it is moving along the rail at some velocity,  $V$ .

There are two ratios that determine the degree to which each of these limiting dynamic cases causes a significant difference between the dynamic response and the static response of the system. For limiting case (1) it is the ratio of the forcing frequency,  $f$ , to the natural frequency,  $f_0$ , of the loaded rail and roadbed. For limiting case (2) it is the ratio of the train speed,  $V$ , to the so-called critical velocity,  $V_c$ , of the rail and roadbed. If  $f/f_0$  is small the effect of imbalance may be neglected; if it is nearly one, then the effects of imbalance are significant and the fact that the wheels are rotating will affect the response of the rails and must be taken into account. If  $V/V_c$  is small then the effect of train velocity is negligible; if it is nearly one then the fact that the train is moving will affect the response of the rails and must be taken into account.

The relative magnitudes of these two ratios indicate the degree to which the limiting cases of (1) and (2) are interdependent. If the ratios are nearly the same the coupling is a maximum and the response of the system cannot be approximated by either limiting case.

Considering limiting case (1) first, the natural frequency of the rail and roadbed, which is the frequency that could be most excited by a stationary harmonic force applied directly to the rail, is given in Reference (19) as

$$f_o = (K/M_r)^{1/2}/2\pi, \text{ cps} \quad (15)$$

where  $K$  = foundation modulus, psi

= soil stiffness per unit length

$M_r$  = mass of rail per unit length, lb-sec<sup>2</sup>/in.<sup>2</sup>

If the harmonic force is due to wheel imbalance, then the forcing frequency is given by

$$f = V/R2\pi, \text{ cps} \quad (16)$$

where  $V$  = velocity of the train, in./sec

$R$  = radius of train wheel, in.

Choosing the following typical physical parameters for conventional track with 140-pound rail,

Rail:  $M_r = 0.0101 \text{ lb-sec}^2/\text{in.}^2$

Soil:  $K = 1500 \text{ lb/in.}^2$

Train:  $R = 18 \text{ in.}$

$V = 160 \text{ mph}$

results in

$$f_o = 61.3 \text{ cps}$$

$$f = 24.9 \text{ cps}$$

$$f/f_o = 0.406 .$$

Considering limiting case (2), the so-called critical velocity,  $V_c$ , of the rail and roadbed is a property of the system similar to the natural frequency,  $f_o$ . It is defined as the lowest velocity at which a free wave will propagate along the rail, and given in References (19), (20), and (21) by the relation

$$V_c = 2\pi f_o/\beta . \quad (17)$$

For the same conventional track with 140-pound steel rail,

$$EI = 2.87 \times 10^9 \text{ lb-in.}^2$$

$$\beta = (K/4EI)^{1/4} = 1.9 \times 10^{-2} \text{ in.}^{-1}$$

from which  $V_c = 2.027 \times 10^4 \text{ in./sec} = 1152 \text{ mph}$

$$V/V_c = 160/1152 = 0.139 .$$

The fact that  $f/f_o = 0.406$  is important because although the frequency ratio is small, it is not quite negligible and, therefore, unbalanced rotating wheels will have some magnifying effect on the forces and deflection of the system. There are two important qualifications to the significance of this conclusion, however. First, the system that it pertains to is the rail and roadbed alone without the large mass of the train resting on it. When this large mass is added to the small rail mass per unit length,  $M_r$ , in Equation (15), a second and lower natural frequency of the system is introduced, giving an  $f/f_o$  ratio greater than 0.406. Secondly, there is surely some damping in the system which, when taken into account, decreases the magnitude of the effect of the rotating unbalance. In fact, for the smallest amount of damping, the one-degree-of-freedom system with  $f/f_o = 0.406$  will experience dynamic contact forces and deflections less than 17 percent greater than their static counterparts.

The fact that  $V/V_c = 0.139$  indicates that for a train speed of 160 mph the dynamic case is not significantly different from the static case. This conclusion was verified experimentally by Birmann<sup>(3)</sup> in his investigations.

**Lumped Parameter Model of Track Structure.** Because the velocity effects can be neglected, it is not necessary to consider the solution of the wave equations for the prediction of track response. For this study of dynamic characteristics, it was concluded that the track could be adequately represented by a single-degree-of-freedom system with a lumped stiffness,  $k_r$ , and an effective rail length,  $L_r$ , which will give an effective lumped mass corresponding to the natural frequency of the distributed system.

The values of  $L_r$  and  $m_r$  are determined by writing Equation (15) in the form

$$2\pi f_o = \left[ \frac{KL_r}{ML_r} \right]^{1/2} = \left[ \frac{k_r}{m_r} \right]^{1/2} \quad (18)$$

and rewriting Equation (2) in the form

$$k_r = \frac{P}{y(0)} = \frac{2K}{\beta} \quad (19)$$

which gives the lumped system parameters

$$L_r = 2/\beta, \text{ in.} \quad (20)$$

$$m_r = M_r L_r, \text{ lb sec}^2/\text{in.} \quad (21)$$

$$k_r = K L_r, \text{ lb/in.} \quad (22)$$

Figure 33 shows a longitudinal beam type of track structure with two wheels and the corresponding lumped-parameter model of this system. The model for a conventional tie-type track structure is the same, with different values for the masses and spring rates.

For inputs, or forcing functions, track irregularities are represented by a time function,  $\epsilon(t)$ , corresponding to spatial variation and train speed so that

$$z_{wr} = z_r + \epsilon(t) \quad (23)$$

$$y_{wr} = y_r + \epsilon(t-t_0)$$

All displacements,  $y$  and  $z$ , are measured relative to static equilibrium positions. Consideration of wheel-lift requires auxiliary equations to calculate the contact force between wheel and rail, and a switching circuit to transfer to modified equations for the lift-off period when the calculated contact force indicates that the total load between wheel and rail, including static weight, is zero.

Although both mass and damping of the rail beam and soil,  $m_{RBS}$  and  $C_{RBS}$  have been included in the model, they can both be neglected so long as the frequencies of interest are less than about  $0.3 f_0$ . Soil (and ballast) damping,  $C_{RBS}$ , is an elusive quantity, but if the damping ratio for the single-degree-of-freedom system is no more than 0.2, the damping can be neglected for all frequencies below about  $0.6 f_0$  with little loss in accuracy.

Effects of Model of Additional Wheels. Figure 16 indicates that if the wheel separation distance,  $L$ , is greater than  $L_r = 2/\beta$ , the coupling between the rail deflections under the different wheels can be neglected. For the nominal track data used herein, this gives an  $L_r = 8.77$  feet. Note that this is the effective rail length used to calculate the dynamic mass, so that if the wheel separation distance is just equal to 8.77 feet, it is easy to visualize the section of rail between the wheels divided equally, both mathematically and physically.

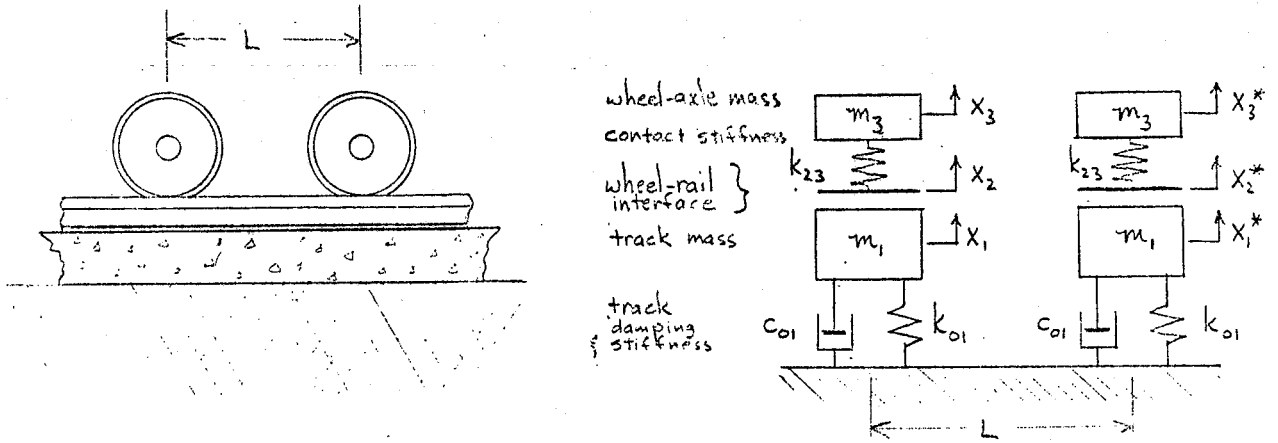

FIGURE 33. LUMPED PARAMETER MODEL OF WHEELS SUPPORTED BY TRACK AND ROADBED

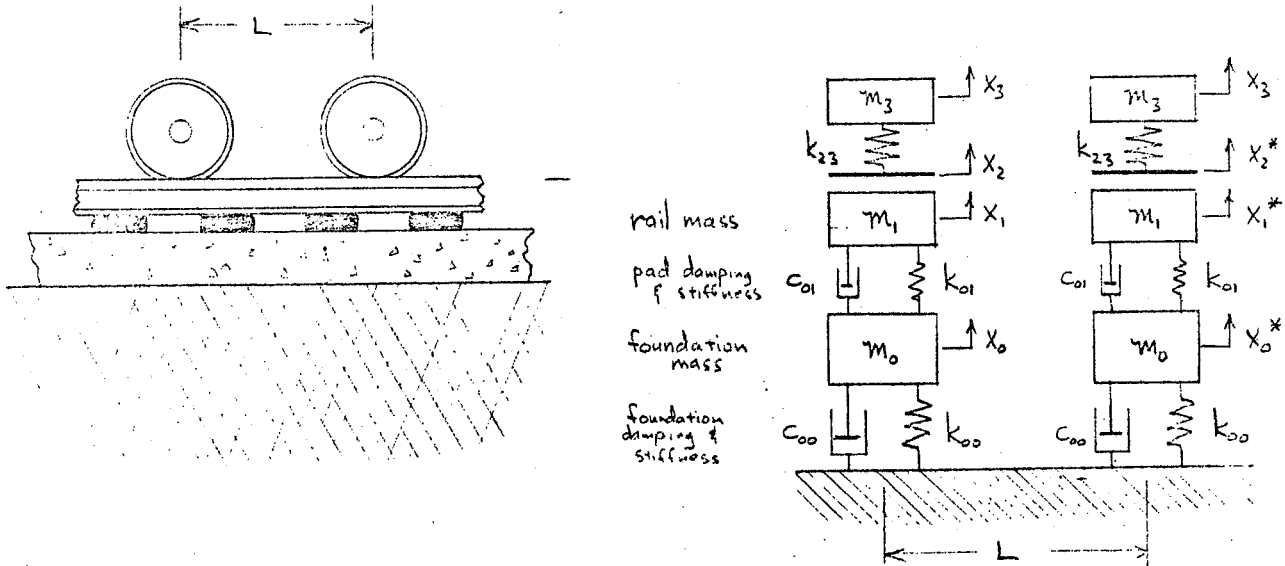

FIGURE 34. LUMPED PARAMETER MODEL OF WHEELS SUPPORTED BY RAILS, SOFT RESILIENT PADS, A TRACK FOUNDATION, AND A ROADBED



When the wheel separation distance is less than  $L_r$ , the response of the two wheels will be coupled through the rail deflections.

Resilient Rail Pad. The model used for a track system containing a resilient rail pad was the double mass-spring system depicted in Figure 34. The lumped mass of the rail,  $m_r$ , and the spring rate of the rail-pad system,  $k_{rp}$ , were determined as described above for a single beam (the rail) on a continuous elastic foundation (the rubber pad). The lumped mass of the beam structure and soil roadbed,  $m_{bs}$ , and its spring rate,  $k_{bs}$ , were determined in the same way, by assuming that this beam structure also acts as a beam on a continuous elastic foundation (the soil).

The lumped damping in the rail and pad,  $c_{rp}$ , was assumed to be 50 percent of the critical damping for the  $m_{rp}$ - $k_{rp}$  system. The lumped damping in the soil and beam,  $c_{bs}$ , was assumed to be 10 percent of the critical damping for the  $m_{bs}$ - $k_{bs}$  system.

Simulation of the Car. The Department of Commerce high-speed test car was used as the vehicle which was simulated on the analog computer, together with the track structure as described above. A functional diagram of this model is shown in Figure 35 (an expansion of the model in Figure 34). Component weights, spring rates, and damping factors used in the simulation were obtained from the car manufacturer or estimated from data used in similar studies. An overall weight of the car on the rails of 100,000 pounds was used. (This simulation was completed before the final weight of the cars was definite. Initially, a weight of 100,000 pounds was estimated by the Department of Commerce and this is the weight used in the simulation. Later, the estimate was increased to 180,000 pounds, but it was felt that for the general trends of interest, the initial weight would be satisfactory.)

Results of Analog Computer Simulation. Three types of runs were made. For one set of runs, sinusoidal track profile errors were used as inputs,  $\epsilon(t)$ , and frequencies were varied to simulate different speeds. Simultaneous identical inputs were used at both wheels, so vertical motions only were considered. These runs were repeated using different pad stiffnesses to determine the effect on the dynamic response of the system. The input for this first set of runs was the error profile

$$\epsilon(t) = (e/2) \sin \omega_e t \quad (24)$$

where  $e$  = peak-to-peak error magnitude

$$\omega_e = 2\pi V/L_e$$

$L_e$  = pitch length of track profile error peaks.

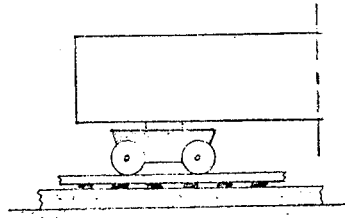

Half of Car Body

Two Suspension Spring and Dampers

One Bolster

One Shock Pad

Spider and Sideframes of One Truck

Bearing Sleeves

Four Wheels and Two Axles

Wheel-Rail Contact Forces

Rail Masses

Rail Pads

Beam Masses

Soil and Ballast Foundation

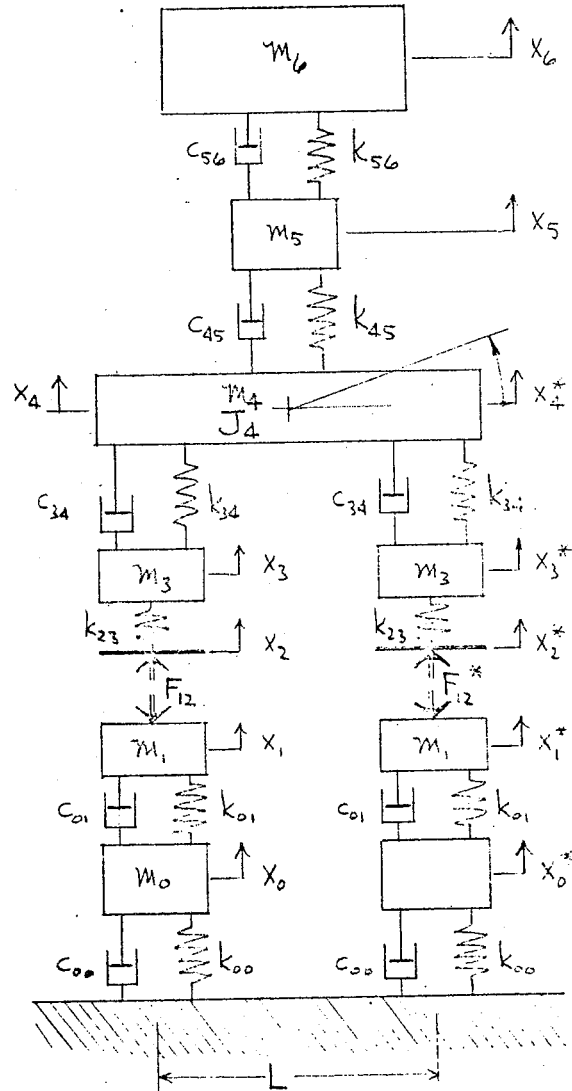

FIGURE 35. LUMPED PARAMETER MODEL REPRESENTING PORTION OF CAR AND TRACK STRUCTURE ASSOCIATED WITH ONE TRUCK

A second set of runs was made to determine the transient response of the car and track to discontinuities on the rail or wheel. This was done by introducing a step error input,  $\epsilon$ , of 0.25 inch. Simultaneous identical inputs were again used at both wheels and runs were repeated using different pad stiffnesses. The input for this second set of runs is represented mathematically by

$$\epsilon(t) = 0, t < 0$$

$$\epsilon(t) = \delta, t > 0.$$

A third set of runs considered an effect which is commonly found in conventional track as a result of track joints. A changing compliance due to proximity of the wheel to the rail joint was used, together with a rectified sine-wave type of track profile which commonly results when rail with joints is used. Pitch of the truck,  $\theta$ , was monitored. These runs were discussed in a monthly progress report and the results of these additional runs are not shown or discussed here.

Sinusoidal Input. In order to determine the effects of pad stiffness on the dynamic response of the car and track, four different track structures, including a conventional track structure, were simulated and subjected to sinusoidal profile error. The four track systems had parameters as listed in Table 5. Track structure A represented a conventional wood tie-and-ballast track, while structures B, C, and D represented advanced track structures having continuous longitudinal beams to support the rails. The only difference between structures B, C, and D physically would be the stiffness of the resilient pad. Note, however, that changes in this stiffness change the effective mass and spring rates of the track structure components.

TABLE 5. SYSTEM PARAMETERS OF FOUR DIFFERENT TRACK STRUCTURES INVESTIGATED IN ANALOG COMPUTER SIMULATION OF CAR AND TRACK

Track Structure	A	B	C	D
$I_R$ , in. <sup>4</sup>	95.6	49.0	49.0	49.0
$K_P$ , pad stiffness, psi	$\infty$	$\infty$	24,000	2,400
$EI_B \times 10^{-9}$ , lb-in. <sup>2</sup>	0	45.0	45.0	45.0
$K$ , soil stiffness, psi	1,500	10,750	10,750	10,750
$m_{RP}$ , lb-sec <sup>2</sup> /in. per wheel	0.895	18.0	0.321	0.572
$k_{RP} \times 10^{-5}$ , lb/in. per wheel	1.58	15.8	10.7	1.91
$m_{BS}$ , lb-sec <sup>2</sup> /in. per wheel	0	0	15.3	15.3
$k_{BS} \times 10^{-5}$ , lb/in. per wheel	$\infty$	$\infty$	13.8	13.8

A sinusoidal track error of  $\epsilon = 0.20$  inch peak-to-peak was used as the input, and the following quantities (all in the vertical direction) were monitored for cases A, B, C, and D as the forcing frequency  $\omega_e$  was varied.

- (1) Car body displacement,  $z_C$
- (2) Car body acceleration,  $\ddot{z}_C$
- (3) Wheel displacement,  $z_W$
- (4) Wheel acceleration,  $\ddot{z}_W$
- (5) Rail displacement,  $z_R$
- (6) Beam structure displacement,  $z_B$ .

The results that showed important effects of changes in pad stiffness have been plotted in Figures 36, 37, and 38.

Figure 36 shows that changing pad stiffness over this large range has an insignificant effect on car body accelerations for input frequencies up to about 6 cps (if the pitch length of the track profile errors,  $L_e$ , were 39 feet this would be equivalent to a speed of  $V = 166$  mph). A peak in car body acceleration and car body displacement (not shown) which occurs at about 2 cps is a result of the natural frequency of the car on its primary suspension system, which for the Budd car is air springs. As the frequency is increased above 6 cps the natural frequency of the unsprung masses on the track are approached and a rapid buildup in acceleration takes place. This increase in car body acceleration is caused by the compression of the suspension springs due to vibration of the unsprung mass. The natural frequency of the unsprung mass on soft pads is lower and, therefore, the acceleration peaks at a lower frequency for softer pads.

The conclusion that the peaks in car body acceleration between 10 and 40 cps (depending on the pad stiffness) are a result of the natural frequency of the unsprung mass on the track structure is verified by corresponding peaks in the displacement of the beam structure at these frequencies, as shown in Figure 37.

These results reflect the fact that two resonant frequencies predominate in the system. These are the car body-main suspension resonant frequencies occurring at approximately 2 cps, and the other is that of the unsprung mass and track masses on the spring rate of the track.

Car body acceleration is an indication of passenger riding comfort and should thus be kept to a minimum. Two ways of accomplishing this are evident:

- (1) a soft pad like D can be used where the maximum acceleration is low but occurs at a lower frequency of error input (large pitched profile errors), or
- (2) a relatively stiff pad or no pad can be used where the maximum acceleration is high but only occurs at high frequencies (short pitched profile errors).

The acceleration curve for track D peaks at 14 cps which is equivalent to an error pitch of  $L_e = 16.1$  feet at 160 mph, and curve A peaks at 40 cps or an error pitch of  $L_e = 4.6$  feet.

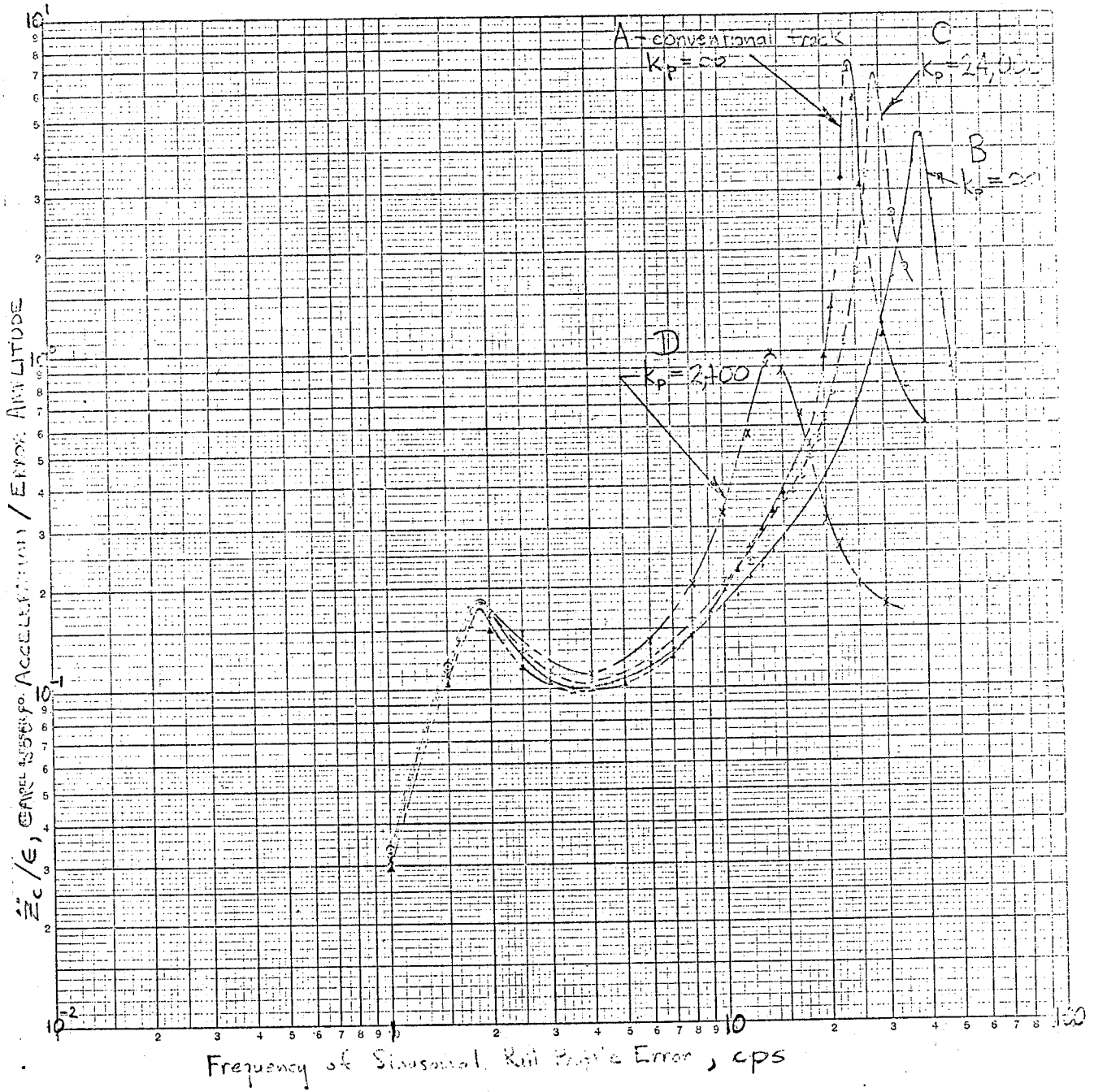

FIGURE 36. CAR BODY ACCELERATION RESPONSE OF 4 TRACK STRUCTURES TO SINUSOIDAL PROFILE ERROR

12.6 Conventional Track (A)

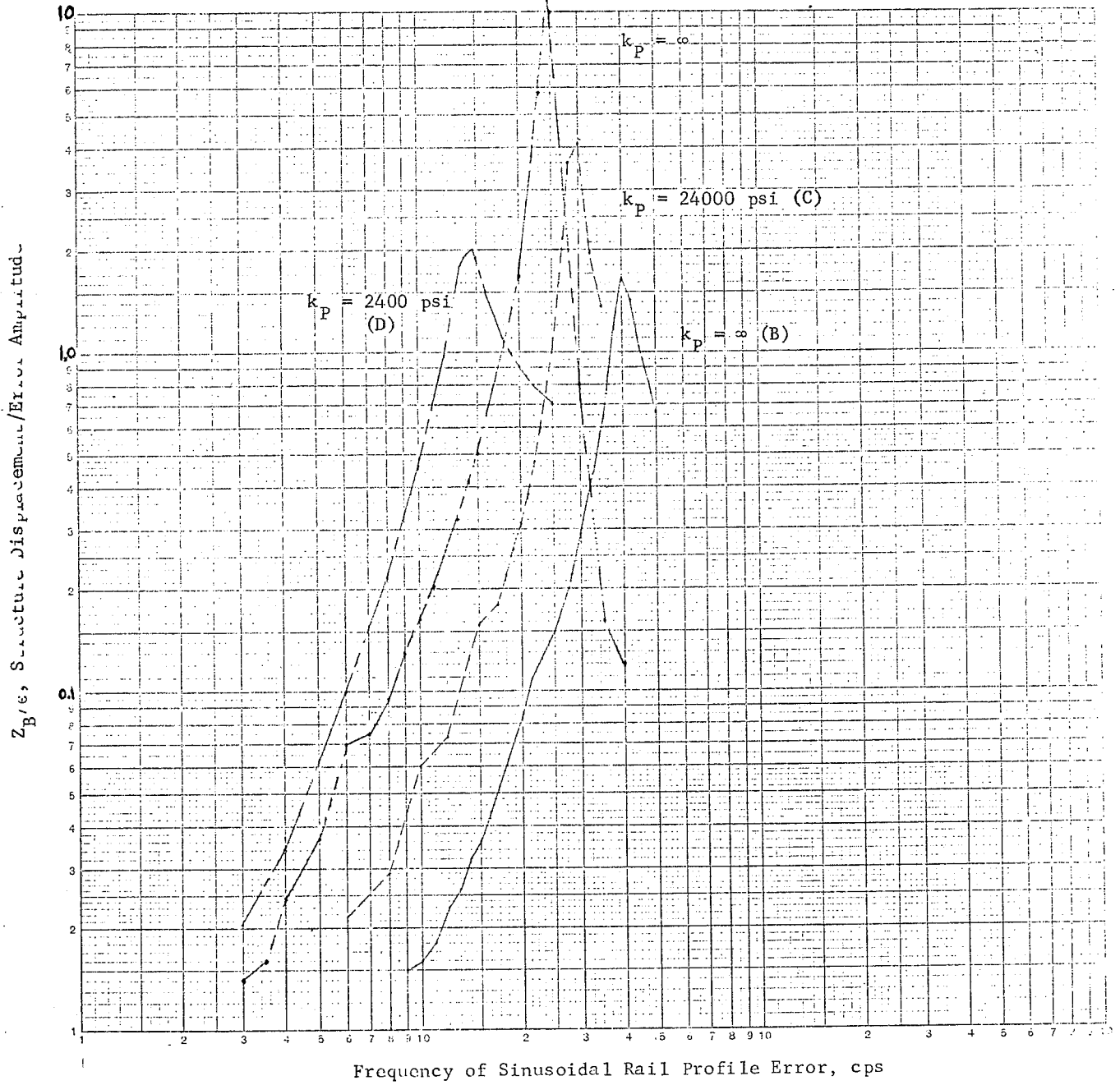
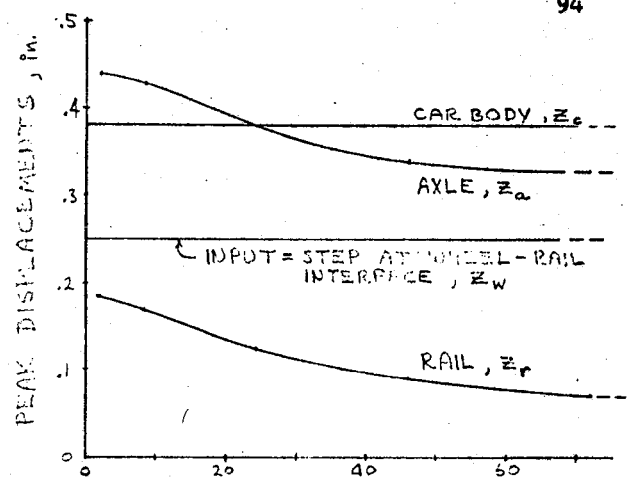

FIGURE 37. RESPONSE OF TRACK STRUCTURE, USING SINUSOIDAL PROFILE INPUT



$EI_B = 45 \times 10^3 \text{ #-in}^2$   
 $k_o = 500 \text{ psi/in}$   
 $W = 21.5 \text{ in}$   
 $K = 10,750 \text{ #/in/in}$

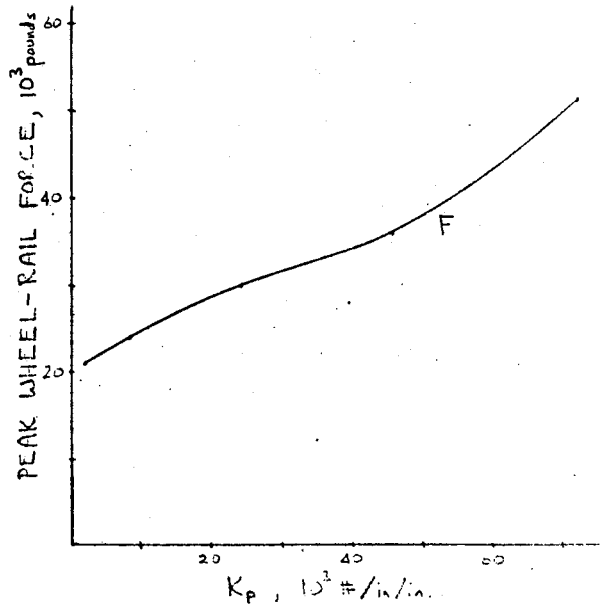
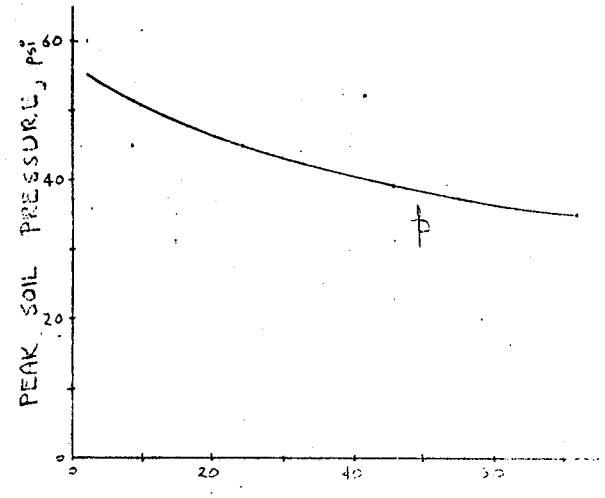
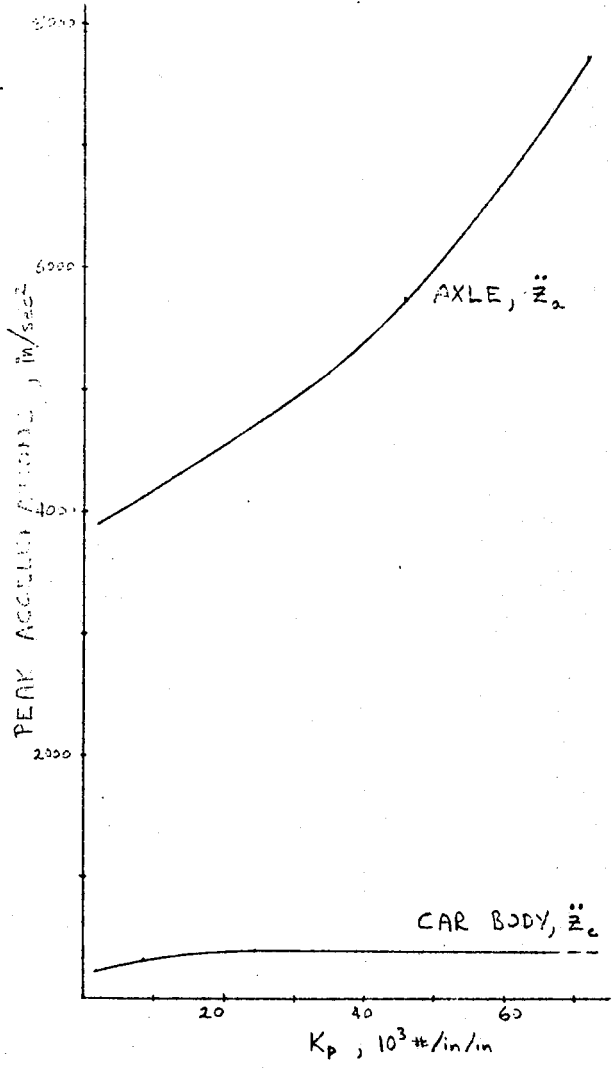

FIGURE 38. EFFECTS OF RAIL PAD STIFFNESS ON RESPONSE OF CAR AND TRACK TO A 1/4-INCH STEP IN THE RAIL PROFILE

The new track structures will be continuous and rigid enough to bridge discontinuities in the subgrade of possibly 10 feet or more and thus it is expected that there will be practically no error in profile that is as short in pitch as 4.6 feet. Large pitch errors (low frequencies) only are expected and thus a relatively stiff pad seems to be desirable on the basis of ride comfort.

By similar reasoning a relatively stiff pad is desirable from the standpoint of soil pressure. Figure 37 shows that at the low frequencies anticipated a stiff pad will result in less deflection of the structure. Since the deflection of the structure is proportional to soil pressure, a stiff pad will result in less soil pressure.

Step Input. A  $\delta = 0.25$ -inch step input was introduced to represent any discontinuities or irregularities in the rail or track structure or a flat spot on a wheel. The purpose was to determine the effects of changes in pad stiffness on the resulting transient response of the car and track. Monitored were:

- (1) Car body displacement,  $z_C$
- (2) Car body acceleration,  $\ddot{z}_C$
- (3) Wheel displacement,  $z_W$
- (4) Wheel acceleration,  $\ddot{z}_W$
- (5) Rail deflection,  $z_R$
- (6) Beam structure deflection,  $z_B$
- (7) Wheel-rail contact force,  $F_{WR}$ .

The peak values of these quantities for the runs made are tabulated in Table 6.

Of greatest interest are the runs E through J, which show the effects of changes in pad stiffness for a particular track structure. The quantities in the table for these runs have been plotted in Figure 38. As pad stiffness is decreased (or compliance is increased), the following trends are evident:

- (1) Car body displacement,  $z_C$ , remains the same
- (2) Car body acceleration,  $\ddot{z}_C$ , decreases only slightly
- (3) Wheel displacement,  $z_W$ , increases slightly
- (4) Wheel acceleration,  $\ddot{z}_W$ , decreases
- (5) Soil pressure,  $p = k_o z_B$ , increases
- (6) Wheel-rail contact force,  $F_{WR}$ , decreases.



TABLE 6. RESULTS OF ANALOG COMPUTER PROGRAM WITH STEP INPUT

		Ten different track structures using A.R.E.A. 100-pound rail									
		E	F	G	H	I	J	K	L	M	N
Structure Properties	Bending stiffness of beam $EI_B$ , lb-in. <sup>2</sup>	45 x 10 <sup>9</sup>					45 x 10 <sup>9</sup>		90 x 10 <sup>9</sup>		
	Soil modulus $k_o$ , psi/in.	500					100		100	500	
	Soil-beam bearing width $W$ , in.	21.5					21.5		43		
	Soil stiffness per unit length $K$ , lb/in./in.	10,750					2,150		4,300		
	Pad stiffness per unit length $K_p$ , lb/in./in.	∞	72,000	46,700	24,000	8,700	2,400	∞	24,000	24,000	
Peak dynamic responses	Car body displacement $Z_c$ , in.	0.38	0.38	0.38	0.38	0.38	0.38	0.35	0.38	0.38	0.38
	Car body acceleration $Z_c''$ , in./sec <sup>2</sup>	190	200	200	190	155	110	210	200	200	190
	Wheel displacement $Z_w$ , in.	0.32	0.33	0.34	0.38	0.43	0.44	0.28	0.32	0.32	0.38
	Wheel acceleration $Z_w''$ , in./sec <sup>2</sup>	15,000	7,750	5,750	4,750	4,250	3,750	20,500	8,000	7,150	4,370
	Rail displacement $Z_r$ , in.	0.070	0.072	0.090	0.125	0.170	0.185	0.060	0.058	0.050	0.120
	Beam displacement $Z_B$ , in.	0.070	0.070	0.078	0.090	0.090	0.120	0.060	0.055	0.050	0.088
	Soil pressure $p$ , psi	35.0	35.0	39.0	45.0	45.0	60.0	6.0	5.5	5.5	44.0
	Wheel-rail force $F$ , lb	90,000	49,500	36,000	30,000	24,000	21,000	132,000	51,000	42,000	27,000

The important curves are the ones for car body acceleration ( $\frac{z}{C}$ ), wheel-rail contact force ( $F_{WR}$ ), and soil pressure ( $p$ ), because of their effects on ride comfort, stresses in the rail and beam structure, and stability of the roadbed, respectively. It appears from the curves that a large stiffness value (i.e., small, but not zero, compliance) would be best. A pad with a stiffness per unit length in the range of  $K_p = 10,000$  to  $25,000$  lb/in./in. is good from the standpoint of the system's response to a step input. This would give a large reduction in wheel-rail contact force as compared to the case of no resilient pad ( $K_p = k_p = \infty$ ) and the car body acceleration would also be reduced somewhat. The soil pressure would be somewhat greater, however.

The additional computer runs for structures K, L, M, and N were made to obtain information other than on the effects caused by a resilient rail pad. By comparing the run H to L and run M to N, the effects of soil stiffness can be obtained. The table shows that high soil stiffness,  $k_o$ , results in low wheel-rail force,  $F_{WR}$ , and in high soil pressure,  $p$ . The low wheel-rail force is, of course, desirable. As far as the soil pressure is concerned, the same reasoning applies as was discussed in the section on digital computer program. That is, the higher pressure occurs on a soil that is capable of withstanding these pressures and is, in fact, loaded less severely than the soil that is subjected to the lesser pressure.

By comparing run L to M and run H to N, the effects of doubling the size of the beam structure can be obtained. Structures M and N are for a continuous slab beam that is 86 inches in total width ( $W = 43$  inches per rail). The bending rigidity per rail for the slab is twice what it is for the individual beam structures L and H. The slab results in a slight decrease in the soil pressure and in wheel-rail force but the car body acceleration is not noticeably altered.

### Conclusions Regarding Resilience

The majority of data obtained from the digital computer program and from the analog simulation were for the purpose of evaluating the merits of using a resilient member between the rail and the beam structure. As was expected, not all of the data lead to the same conclusion and, therefore, a compromise had to be made.

The results of the digital computer program brought out the fact that, in the static case, a resilient member would not reduce the soil pressure significantly unless it was made impractically soft. The results also revealed that the stiffness of the member affected the relative magnitudes of the bending moment in the rail and beam structure. For example, a very stiff pad would result in a low bending moment in the rail and a high bending moment in the beam structure. It is desirable to keep the bending stresses in the rail to a minimum, and the beam structure has reserve strength because it has been designed on the basis of stiffness; therefore, from the standpoint of the static stresses in the track structure, a relatively stiff pad is desirable.

The majority of the data from the analog simulation also lead to the conclusion that a fairly stiff pad is best. For periodic or sinusoidal profile

errors the car body acceleration and the soil pressure are minimized by using a very stiff pad. For a step input the only quantity that is significantly affected by the resilience is the wheel-rail reactive force. For an infinitely stiff pad, the force is very large for a step but it can be decreased substantially by only slightly decreasing the stiffness. This force is of importance because of the stresses and the wear that result, and must be kept low.

The use of some amount of resilience between the rail and the beam thus appears to be attractive. A value of stiffness on the order of 25,000 lb/in./in. of longitudinal length for each rail seems reasonable.

In physical terms, this stiffness can be obtained either by a continuous resilient member or individual resilient pads spaced at discrete intervals. Calculations indicated that with 3-foot spacing, 70 Durometer neoprene pads 12 x 14 x 0.4 inches, having a shape factor (bearing area/bulge area) of 1.33, could be used. Of course, many designs are possible, but this one was based on minimum cost, implying minimum volume of a relatively low-cost material.

#### Rail and Rail Attachment Devices

The concept of each advanced track structure which evolved during this project can be considered to consist of three components: a rail, a foundation to support the rail and transfer loads to the earth, and the fastener or rail attachment device which holds the rail and transmits loads to the foundation. These three components cooperate to perform two basic functions: the guidance and support of high-speed trains.

The foundation structure has already been discussed, and it was shown that any of several designs of longitudinal beams beneath the track can be used to provide a stable base for the track structure. This is true, regardless of what rail and attachment device is used. The interface between the rail or rail attachment device and the structure is, of course, an extremely important one, since all loads must pass through the interface into the structure. Electrical characteristics are also dependent on this interface. From these standpoints, the rail, rail attachment, and structure must be considered as a unit.

The design of the rail itself was limited only by the stipulation that the gage and the railhead contour must remain unchanged from standard practice. These two restrictions meant that relatively little could be done to reduce wear and contact stresses at the wheel-rail interface.

One exception to this stipulation may be possible. With the more stable and accurate structures recommended, the rail surface should be aligned more precisely with the surface of the train wheels than is now possible. This should permit a larger crown radius to be used on top of the rail without danger of corner contact. The increased crown radius would result in reduced contact stresses on the rail and wheel. This approach was not pursued in this project as it did not affect the feasibility of any of the rail or structure designs considered.

Although rails made of other materials, such as polyurethane, have been described in the literature, steel is the one material which is relatively cheap and yet can withstand the extremely high contact stresses generated with conventional wheel loads and railhead contours. Therefore, no attempts were made to design rails which were not made from steel.

However, considerable benefits in the form of reduced wear and lower stresses can be expected just from the fact that the combination of a more accurate track structure and an advanced vehicle (one whose trucks are designed to have much less severe vibrations--particularly hunting--than present trucks), will greatly improve the load-stress situation at the wheel-rail interface by minimizing vertical and lateral impact loads. Therefore, just the use of a more accurate track structure should reduce maintenance on the vehicles as well as on the track (vehicle maintenance due to bad track is often overlooked when calculating present maintenance costs).

From the railhead on down, however, there were no limitations, and several unique rail cross-sections were designed to meet particular design requirements.

It was assumed that in an advanced track structure, provisions for adjusting the rail relative to the foundation should be included. If it were not for the adjustment feature, the fastener design would be simple. However, regardless of the track foundation, it seems inevitable that over long time periods some differential settlement of the ground will occur that is gross enough to affect the alignment of the rails. To compensate for this it will be necessary to provide in the fastener some means of adjusting the rails relative to the foundation. Also, some degree of adjustability is needed at the time of installation of the structure, for the rails will need to be initially aligned very accurately in relation to the relatively crude steel and/or concrete foundation supporting them.

The basic problem, then, in the design of the fastener, is to provide as continuous and solid a connection between the rails and foundation as possible, while still providing for adjustment of rail position, relative to the foundation, from time to time. It is a difficult problem to solve satisfactorily, since there are few practical and economical schemes that will provide for adjustment of the rail to different heights and lateral positions at different points along the track, while at the same time maintaining continuous support of the rail. However, several solutions to the rail fastener problem were conceived, as discussed shortly.

### Rail Design

An important aspect of the rail problem, as pointed out by the Department of Commerce, is the fact that standard rail design is wasteful, inasmuch as only the surface of the head wears away and the entire rail must be scrapped when it does. Also, the present design is unsatisfactory because the head-web fillet stresses are concentrated so much that they cause plastic yielding under high loads. Both wear and yielding combine to decrease the useful life of the rail, and when the rail is replaced, the large amount of

steel in the entire rail must be replaced to make up for a small amount of steel which has worn away, shelled, or spalled.

To alleviate these problems, several alternate rail sections were designed, each having either more wheel-contact areas or less cross-sectional area, or both. One extreme is a rail which can be worn, rotated, and worn again until several surfaces have been worn by the wheel at some time in its long life; the other extreme is a permanent rail under a thin shell having one or two wearing surfaces that can be replaced with as little waste as a brake lining on a shoe.

Six nonstandard rail designs are depicted in Figure 39. They were designed not only to effect some combination of less area and/or more wheel-contact surfaces, but also to be symmetrical about one or more axes (thus being interchangeable from one side of the track to the other), and capable of being manufactured by rolling. These rails are described as multiheaded, flangeless, and replaceable headed.

The multiheaded rail concept is shown in Figure 39a and b. Like standard rail, when worn on one side of one head they can be switched to the other side of the track to wear the other side of the head. Unlike standard rail, however, when a head is worn on both sides there are one or two more heads available by rotating the rail. These rails have as much or more bending stiffness as standard rail, and yet are much more efficient in terms of less "waste" steel. If the vertical wheel loads are transmitted directly from the wheels through the head to the supporting fixture without going through the web constriction, there is less likelihood of stress concentration causing plastic yielding. There may be stress-concentration problems though if the loads are transferred through holes or slots in the railweb. Neither of the rails can be supported positively on the lower head(s) because all heads will eventually change in profile due to wear. The three-headed rail can be supported between the lower heads, however. Several suitable attachment devices are discussed in the next section.

One of the consequences of replacing the conventional lower flange by another railhead, as in the two-headed rail, is a decrease in bending stiffness laterally. This gives the two-headed rail a greater tendency to lose its lateral alignment and concentration for this weakness must be made by the support fixtures. On the other hand, with the three-headed rail designs the lateral stiffness is greater than that of a standard rail.

The flangeless rail (shown in Figure 39c), in order to have an economic advantage over standard rails, must have a smaller rail cross-section area and so almost certainly will be weaker in bending. As mentioned before, this is not necessarily detrimental in view of the fact that the standard rail must provide all of the bending strength of conventional tie-and-ballast track, but only a fraction of that in the advanced track structures where the longitudinal beam foundation provides a great amount of bending strength. At any rate, the lack of strength in the rail can also be compensated for by a continuous or semicontinuous support fixture.

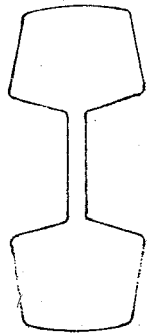

(a) Double-headed rail

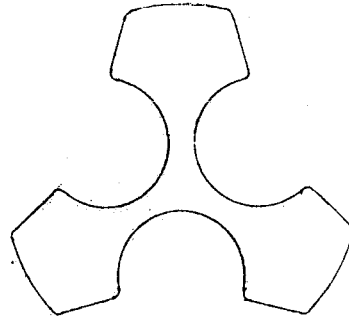

(b) Triple-headed rail

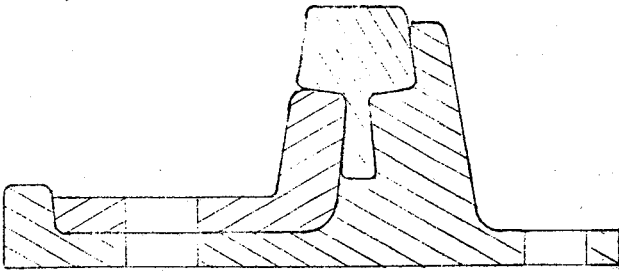

(c) Flangeless rail

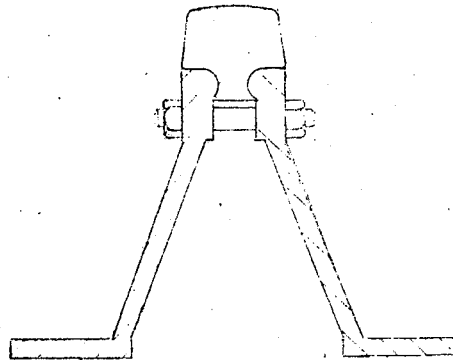

(d) Three-piece rail with replaceable head and large bending stiffness

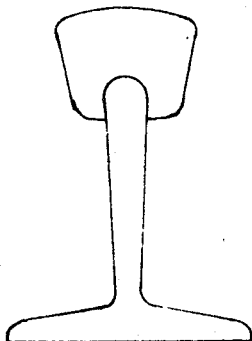

(e) Conventional rail with replaceable head

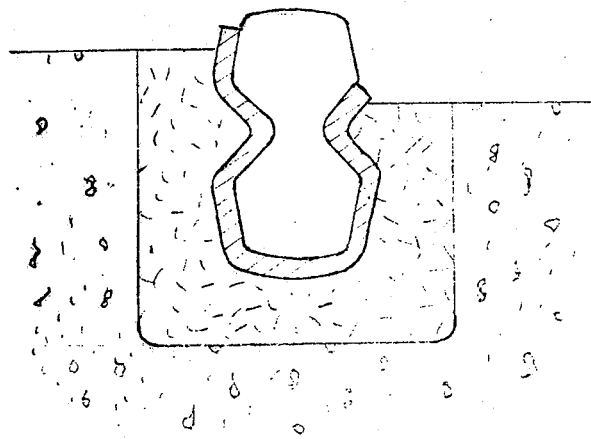

(f) Encapsulated reversible rail

FIGURE 39. DESIGN CONCEPTS FOR NONSTANDARD RAILS

The replaceable head rails (shown in Figure 39d and e) have, in effect, a continuous support fixture (which need not be symmetrical) in the permanent part of the rail. The big advantage to the shell is that the amount of steel scrapped would be of the same order of magnitude as the amount of steel worn away and, when replacement is made, both the cost of material and the time and effort involved would be small, the latter mainly because no removal or re-adjustment of fixtures would be necessary. The main potential problem with the shell would be to obtain a good fit between it and the supporting steel beam. The shells would need to be designed carefully to insure that stress levels are acceptable.

For most of the rail concepts mentioned above, one or more fixtures are described in the next section that have been designed to give adequate support and adjustability to the rail and, in some cases, to augment the bending stiffness of the rail.

Still another type of rail cross section is dictated by one of the more unique rail attachment methods proposed. This method is discussed in detail later in the report, but essentially consists of placing the rail accurately in a large groove in the supporting structure and surrounding the lower portion of the rail with a liquid material which then solidifies. Depending on the material used, it might be desirable to minimize the amount (and cost) of the material, leading to a rail cross section such as that shown in Figure 39f, in which a two-headed cross section is approached.

Finally, it is likely that conventional rail will be used in some applications. This should be considered then for one of the rail designs, and several rail fasteners were designed to support and allow adjustment of conventional rail.

#### Rail Support and Attachment Devices

As mentioned before, the basic problem in the design of the rail attachment device is to provide as continuous a support as possible, while still providing for adjustment of the rail both vertically and laterally relative to the supporting structure.

The use of a continuous longitudinal structure beneath the rails immediately suggests the possibility of providing continuous support in the form of a resilient strip of material between the rail and the structure. However, the problem here is to provide for later adjustment of the rail and, in fact, to bridge a varying distance between rail and structure which exists by virtue of having a relatively accurate rail resting on a relatively inaccurate structure. This can be solved when the rail is initially installed by using a liquid material, such as a liquid rubber, which will solidify in a short time. However, if the rail is later adjusted due to gross settling of the foundation, the irregular strip would need to be completely or partially replaced.

Continuous support can be approximated by using discrete fastening and attachment devices spaced at close intervals. With conventional track structures, the rails are nominally supported every 21 to 30 inches (depending on the type of construction), but shifting of the ballast often makes the support very

nonuniform. With continuous longitudinal foundation beams, however, fasteners at discrete intervals would more nearly approach continuous support. If adjustment devices are provided in each fastener, this may become expensive. One way to get around this situation is to use a rail having a high bending stiffness, supporting the rail with adjustable rail attachment devices spaced at intervals of 10 to 15 feet, and then to provide simpler intermediate supports between the adjustable ones.

Regardless of the method used to fasten the rail to the structure, care must be taken to ensure that forces due to temperature changes can be withstood. The longitudinal stress in a continuous welded steel rail due to temperature changes of 70 F will be approximately 14,000 psi, which can be withstood by steel with no difficulty. However, if a continuous concrete structure is used to support the rail, the temperature changes experienced by the rail will be much greater than those of the concrete. The rail attachments must be such that the forces between the rail and foundation beam can be withstood without slippage.

Of the many designs proposed for rail attachment, several were selected as having real merit. In some cases, the rail fastener was dictated entirely by the rail design. For example, considering first the possibility of using a continuously supported rail, the concept of "potting" the rail into a groove in the concrete support structure was developed. Because of the continuous support, both vertically and laterally, provided by this method, a rail with a small cross section can be used and, from this standpoint, the rail is very efficient. However, if adjustment of the rail is required it will be necessary to replace much of the potting material, which is inefficient.

On the other extreme, the use of widely spaced discrete fasteners dictates a rail with high bending stiffness, both vertically and laterally. To avoid waste associated with a large rail cross section required for this bending stiffness, the replaceable railhead design (Figure 39d) is appropriate when widely spaced discrete fasteners are used.

For all attachments discussed in this section of the report a vertical adjustment of  $\pm 3/4$  inch and a lateral adjustment of  $\pm 1/2$  inch has been provided. As the amount of adjustment increases, so does the cost.

Continuous Rail Support. A distinctly unique method proposed for supporting the rail without peripheral fixture hardware of any kind was that of "potting" the rail up to the railhead in a trough filled with a remeltable metal or elastomer. This concept is shown in Figure 40. For initial installation the rail would be held accurately by external means and the material would be poured in around it. When and if realignment of the rail was necessary, the material would simply be remelted by heating or removed and replaced. If the melting method were used the rail would then be moved to its new position and held there by external means until the material had rehardened around it. Because of the lack of fastener hardware, this operation could probably be automated without difficulty.

This support method is considered feasible, its use depending on whether present materials will satisfy the engineering requirements of the



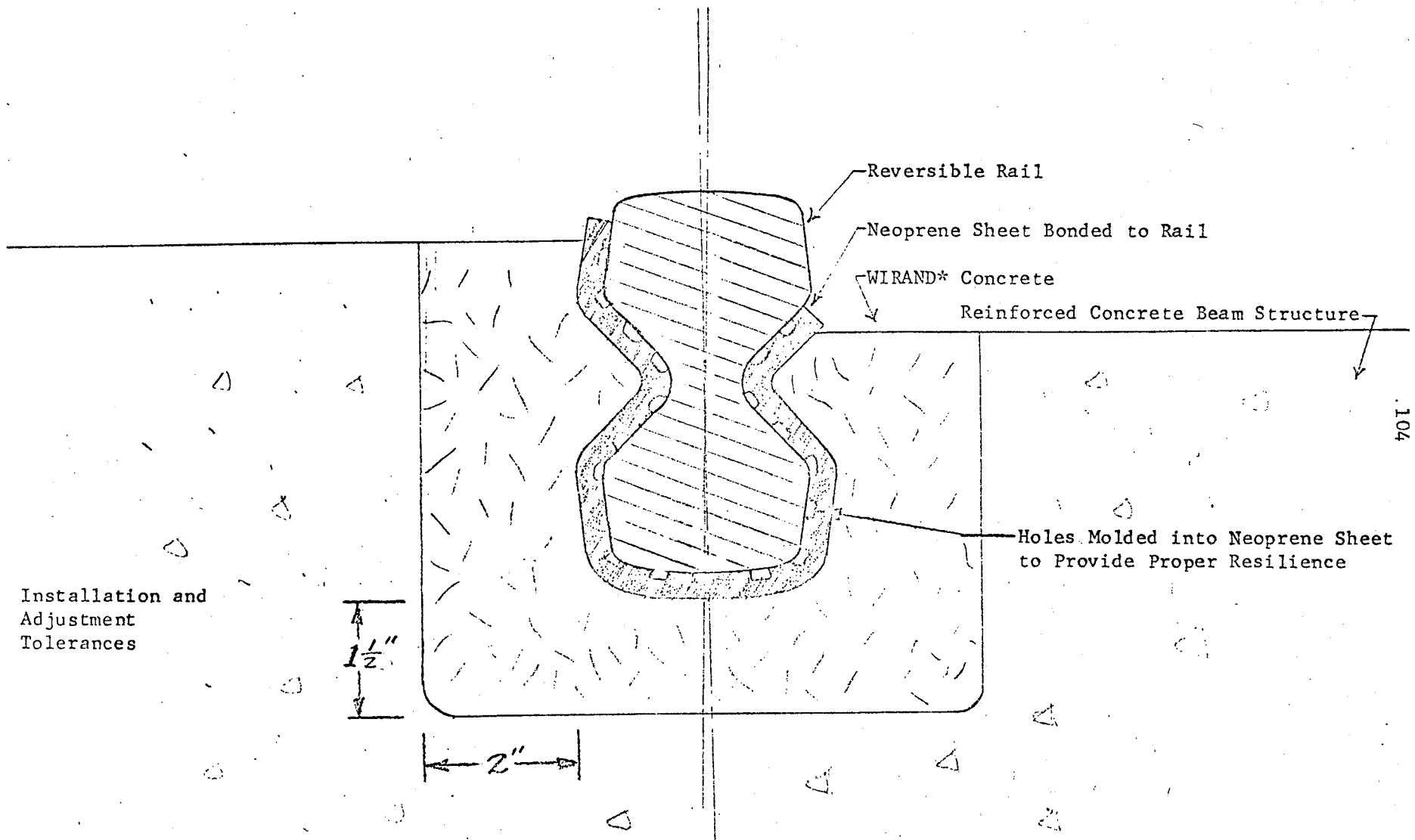

\*Trademark of the Battelle Development Corporation

FIGURE 49. ENCAPSULATED RAIL DESIGN FEATURING REVERSIBLE RAIL MOUNTED RESILIENTLY IN CONCRETE

problem and yet not be too expensive. Some of the more important engineering requirements are high compressive strength and resistance to creep or cold-flow, toughness, capability of being installed in a liquid state, a high degree of immunity from damage by the elements (such as water, oil, sunlight, and fungi), and some resilience and flexibility.

The idea was discussed with Battelle specialists in the fields of non-ferrous metallurgy and rubber and plastics technology. It was found that, although metals are available which could be remelted, the costs might be prohibitive. On the other hand, it appeared that rubber or plastics which could do the job and still be remelted are not available, meaning that the material would have to be replaced when the rail was realigned. This, of course, introduces a cost factor into the problem. If the material must be replaced when the track is realigned, the possibility occurs of using concrete grout. With either the metal or concrete, it would be desirable to provide a layer of resilient material around the rail to give the desired track resilience.

Considering first the metal, most nonferrous metal candidates, like Wood's Metal, are very costly because of their high bismuth, tin, and/or antimony content. Probably the cheapest metal available for this application is lead with 7 percent antimony, which (for a minimum cross section of 6 in.<sup>2</sup> around each rail) would cost \$43,000 per mile for material alone. Besides the expense there are other problems in the use of lead alloys, namely the tendencies for the lead-steel rail interface to corrode, for the lead to creep under load, and for the concrete trough to dehydrate and crack at the 500 F melting temperature of lead.

The best selection for a rubber or plastic material would almost certainly be a castable polyurethane. However, although polyurethanes cure from a liquid at about 212 F to a rubbery solid, they cannot be reliquefied. Heating only softens them, which degrades their physical properties and then chars them without melting. So the solidified urethane must be destroyed to realign the rail potted in it. This may or may not be acceptable, depending on how often the rail turns out to need realignment, because the material cost of a good candidate polyurethane may be high. DuPont's Adiprene-L vulcanizates are typical of this class of polymers. They are tough, have high load-bearing capacities, great resistance to compression set, thermal shock, and abrasion, are good electrical insulators, and are impervious to oil, solvent, fungus, oxidation, ozone, and water. They have been used for gears, solid tires, and even metal-forming tools.

The main disadvantage of all remeltable polymers is their high tendency to creep, because cold flow and melting are essentially the same mechanism in a polymer--if the polymer has a melting point, it will also creep indefinitely.

Butyl compounds which are used for tie pads to deaden noise and vibration tend to show high compression set in thick sections, but should be considered.

Rigid plastics are not tough enough. Battelle's experience with polymers used as rail joint insulators indicates that they disintegrate under rail-expansion loads because they cannot deflect enough elastically. Even a material with a compressive strength of 50,000 psi (stronger than most polyurethanes) crumbled like popcorn in this high-load application. However, the

stresses in the material surrounding the rail would be much less than those in the rail expansion joints.

To determine the practicality of this means of rail mounting, cost estimates of various materials which might be used to contain the rail were made. It was quickly found that the area of material other than concrete should be minimized, based on the following numbers:

Material	Cost Per Square Inch of Cross Section Per Foot of Rail, Installed, \$
Cheapest suitable meltable metal (lead with 7 per- cent antimony)	0.68
Steel	0.85
Neoprene	1.20
WIRAND* concrete (for tension and compression strength)	0.08

Based on these costs, it was concluded that the cross-sectional area should be minimized, and that the most economical way to mount the rail would be to wrap it partially with a 1/4 to 3/8-inch-thick resilient sheet, such as neoprene, and then to grout it in place in the groove with WIRAND concrete. The size of the groove should be minimized, with the adjustment tolerance being the limiting factor. Costs shown in the tabulation above are based on a neoprene cross-sectional area of 5.2 in.<sup>2</sup> per rail, and a reinforced-concrete grout area of 5.2 in.<sup>2</sup> per rail, and a reinforced-concrete grout area of 35.3 in.<sup>2</sup> per rail. The neoprene sheet would be designed with a shape factor chosen to obtain the desired resilience.

Discrete Fasteners. The majority of the fasteners devised were hardware fixtures that are fixed to the foundation at regular intervals, and offer adjustability and complete constraint to the rail only at these stations.

For purposes of organization and evaluation, all fasteners can be considered to have three functions: support, hold-down, and adjustability. Each fixture must incorporate within itself the means to accomplish these three ends both vertically and laterally.

When the design has many parts, each performing a single function, the parts themselves are generally simpler and some parts can be made from continuous

---

\*Trademark of the Battelle Development Corporation.

elements, such as rolled steel sections. On the other hand, fasteners that can do the same job with fewer parts may be more complex in shape and will have to compromise more of their support and hold-down continuity. Neither many-piece simple fasteners nor few-piece complex fasteners have an obvious economic or reliability advantage over the other. It was thought desirable, however, to eliminate as many pieces as possible, if for no other reason than to minimize the number of interfaces and the problems associated with them. Simplicity and quantity of fastener components are two of the bases which led to the chosen fastener designs.

The degree to which continuous support is approached with discrete fasteners depends on the stiffnesses of the rail, the support foundation, the fasteners themselves, and the spacing of the fasteners. Although the number of fasteners needed decreases as the spacing interval is increased, the loads per fastener increase, meaning the fastener's size will also increase.

Whenever continuity of support between the rails and the foundation is interrupted by a space between attachment fixtures, then the fastener has a more complicated hold-down requirement because the rail is free to deflect downward between supports. The situation is akin to that of standard tie and ballast track structures where the rail flexes under a passing train and rocks over the ties. This condition is not going to be nearly as apparent in the proposed advanced track structure, but the fact remains that the rail will tend to flex and this tendency will be greater if it rests on widely spaced platforms above the foundation. This flexing presents a problem to fasteners even on continuous supports over a rigid foundation. This proved to be a problem in a concrete track structure used by the Pere Marquette Railroad in the 1920's<sup>(2)</sup>. The fasteners that restrain the rail must either prevent flexure or accommodate it, without fatigue failure in either case.

It is the hold-down component of the fastener that is the primary victim of fatigue, since it is subject to tension. Hold-down is effected in most of the discrete-fixture fasteners by tightened bolts, spring clips, or pins. The possibility of fatigue in any of these has been minimized by cushioning the part from a change in stress level with resilient interfaces that absorb the rail flexure, or by making the part massive enough to absorb the flexure without significant stress variation.

The third function of the fastener is a capability for vertical and lateral adjustment. Several combinations of adjust-and-hold devices are used in the designs shown in Figure 41. The methods of adjusting one surface relative to another and holding it there are relatively few. They are all some variation of friction, wedges, screws, shims, and eccentrics. Adjustment of position can be made in finite step-wise increments or it can be infinitely variable over the range of position required. The former results in a generally more stable, strong, and positive a position, but is by nature approximate and requires more complexity of fastener parts and/or mating surfaces, and so will tend to be more costly. The latter is simpler and more adaptable, but its retention of position is largely dependent on friction. Since position holding is more difficult in the vertical direction it is advisable to avoid relying on continuously variable vertical positioning with friction holding.

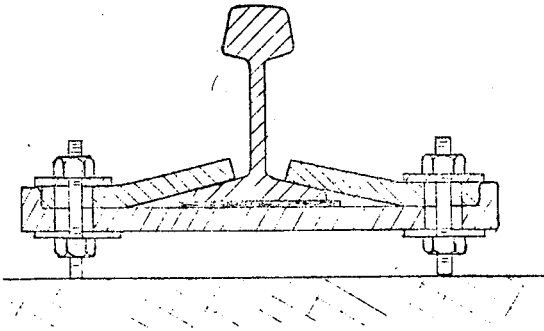

(a) Uses screw threads and friction for vertical and lateral adjust and hold

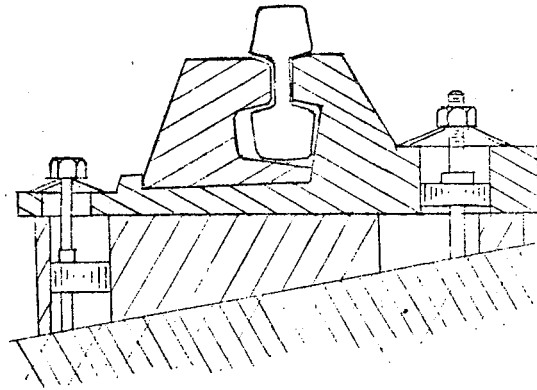

(b) Uses wedge and splined eccentrics for vertical and lateral adjust and hold

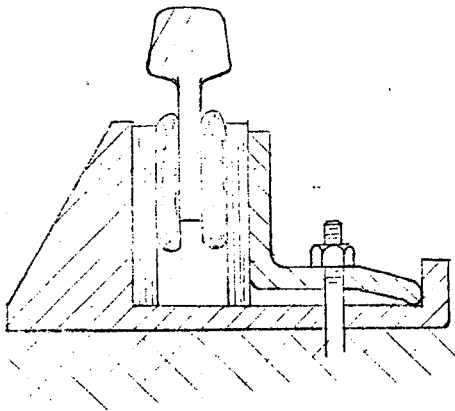

(c) Uses rubber-in-shear friction and shims for vertical and lateral adjust and hold

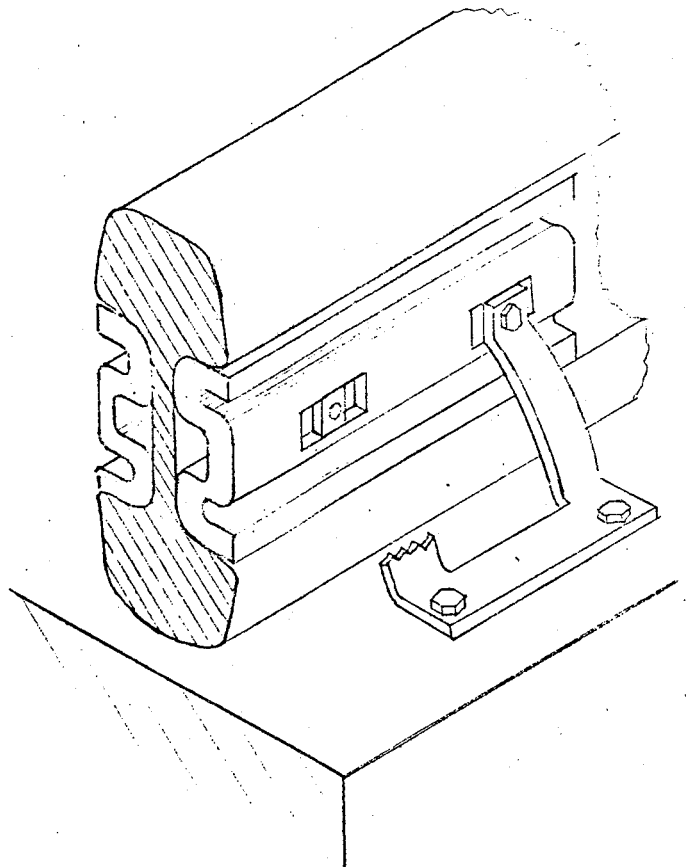

(d) Uses eccentric inserts for vertical adjust and hold (see Figure 44b)

FIGURE 41. DESIGN CONCEPTS FOR ADJUSTABLE RAIL ATTACHMENT DEVICES

Attachment of Fastener to Support Foundation. Three different methods of obtaining a good connection of a discrete fastener with the support foundation were considered to be appropriate. All three methods lead to the same result--that is, steel studs or bolts projecting up from the foundation.

Considering first concrete foundations, there are three ways to provide support for the rail fasteners. First, U-shaped reinforcing rods can be placed in the concrete with the ends projecting, as shown in Figure 42a. The spacing between the two projecting studs would be maintained very accurately with this method, and by use of a form across the top of the concrete, the studs could be accurately placed relative to the edges of the concrete structure.

The second method (Figure 42b) is a variation of the first; instead of placing projecting studs in the concrete, female plugs would be embedded into it flush with the surface. Treated studs could then be screwed into the inserts to provide projecting studs to support the rail fastener. The advantage of this method is that if a stud breaks it can be more easily replaced.

The third method would be to embed a steel plate with projecting studs into the concrete, as shown in Figure 42c. Instead of using a flat plate any desired cross section could be used, such as a channel or flange, to integrate with the fastener design. Or, projecting studs could be welded to the plates to support the fastener.

Regardless of which of the three methods are used with the reinforced concrete, the net result could be the same, so that cost would be the deciding factor.

For all-steel structures or composite structures in which a steel surface is exposed at the top, studs could be welded to the steel or holes drilled and tapped for bolts.

Fastener for Standard Rail. Figure 43 is a cross section of the fastener assembly recommended for use with standard rail. It is simple and adjustable, provides positive platform support of the rail flange, rests flat on the concrete or steel foundation, and holds the rail down firmly.

Vertical adjustment is accomplished by adding or removing shims that snap in place around the studs projecting from the foundation and so cannot migrate out from between the rail and foundation.

Lateral adjustment is accomplished by means of hexagonal eccentric sleeves (see Figure 44a) that slip over the foundation studs and fit into hexagonal or square holes punched in the hold-down plate on both sides of the rail, providing both positive variable location of the rail between the studs and a solid lateral force path (that does not depend on friction) from the rail flange to the foundation studs. The rail and its hold-down plate can have six lateral positions between the foundation studs, depending on which of the six flat faces of the eccentric sleeve is indexed to bear against the flat flange-side face of the hole in the hold-down plate, because each of the sleeve's six faces are a different distance from the stud it is indexed around. In the assembly shown the lateral position can be adjusted over a range of 1 inch in

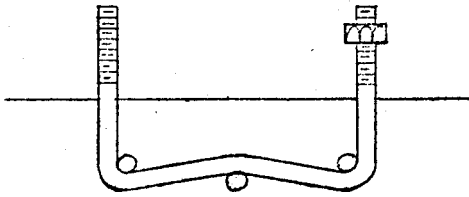

(a)

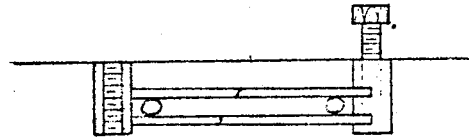

(b)

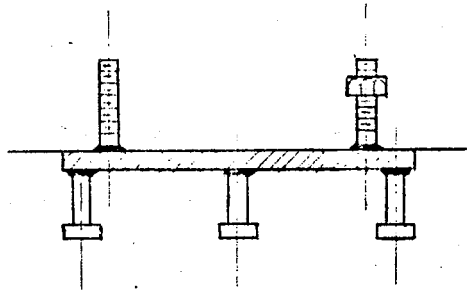

(c)

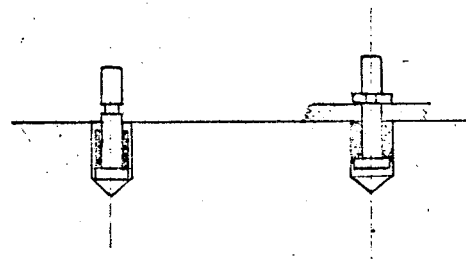
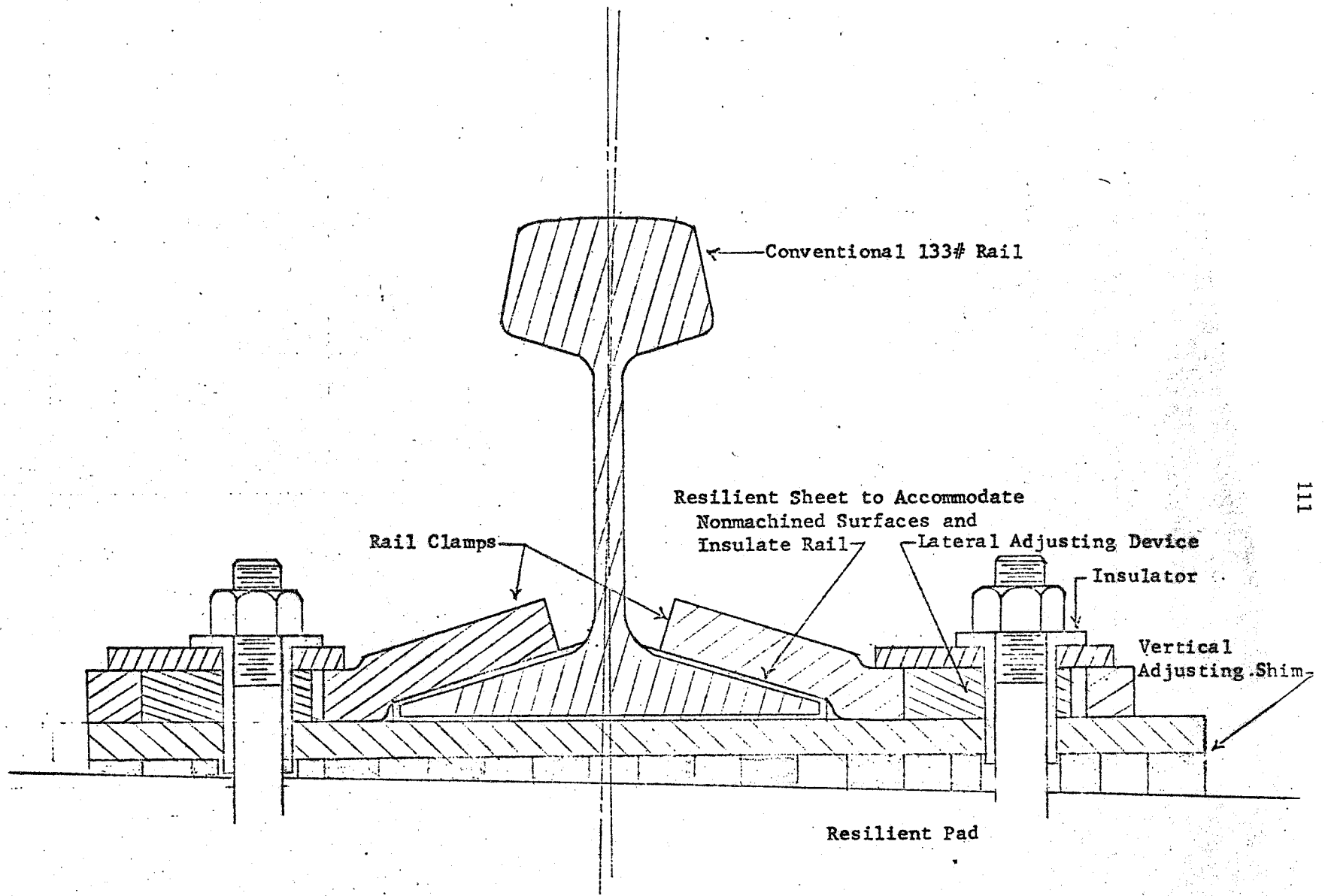

FIGURE 42. RAIL ATTACHMENT TO BEAM STRUCTURE



111

FIGURE 43. ATTACHMENT DEVICE FOR STANDARD RAIL



$X$  = Distance from  $\phi$  of stationary foundation stud to movable rail fixture

INDEX INSERT TO GET

$$X = .7" \text{ to } 1.7"$$

INCREMENTS OF

$$\Delta X = .2"$$

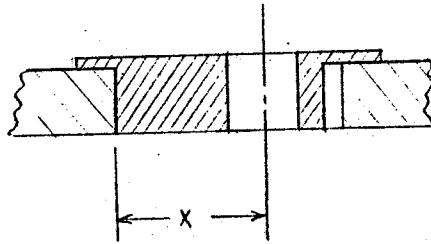
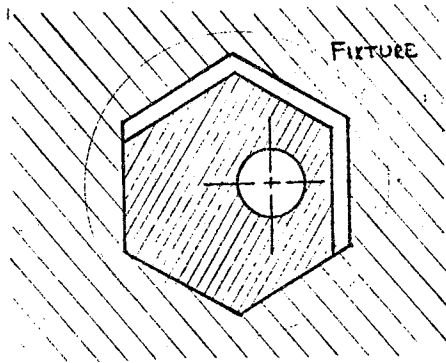

(a) ECCENTRIC HEXAGON

INDEX INSERT TO GET

$$X = 1.0" \text{ to } 1.9375"$$

INCREMENTS OF

$$\Delta X = .0625"$$

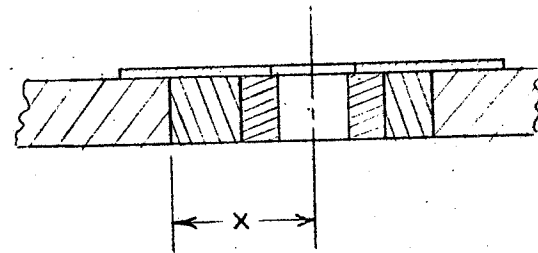
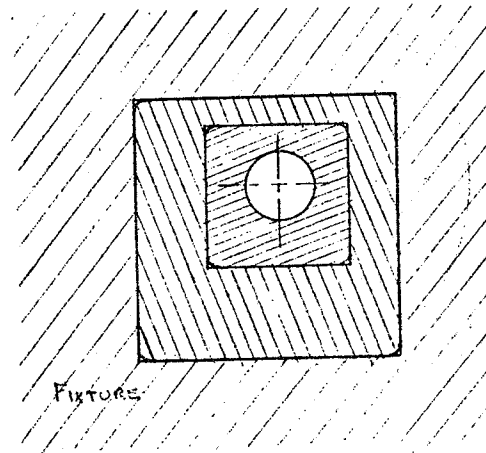

(b) DOUBLE ECCENTRIC SQUARES

FIGURE 44. ECCENTRIC INSERTS FOR ADJUSTING AND HOLDING RAIL Laterally

equal steps of 1/5 inch. This means a maximum error from "true" alignment of 1/10 inch, which is likely to be sufficiently accurate. If the adjustment must be finer, then the eccentric insert sleeve can be made as shown in Figure 44b where the sleeve consists of two squares with eccentric holes and can effect an adjustment over a range of 1 inch in equal steps of 1/16 inch, which means that the track can be aligned to within 1/32 inch of reference at each fastener station. However, this alternative is definitely more expensive than the hexagonal eccentric one-piece sleeve. Both adjustments presuppose that the studs can be installed to within 1/2 inch of the intended rail alignment.

The fact that both the vertical and lateral adjustment of this fastener assembly is approximate in nature may be considered as a slight disadvantage, but it must be weighed against the fact that the alignment achieved relative to the foundation cannot be lost or changed unless the fastener is disassembled or destroyed. If a smooth-faced eccentric were used, for instance, it might index itself around under the vibration of a passing train, changing the alignment. This is an even greater potential problem if slotted holes and friction were used instead of an indexing sleeve insert. The problem with slots is not that the rail will definitely lose its alignment, but rather that the possibility exists which requires the alignment be under closer surveillance, which costs money.

One of the advantages of this fastener assembly is its strength. It is compact and solidly interlocked with itself, the rail, and the foundation. The most plausible means of failure is through fatigue of the foundation studs. This fatigue is minimized by using 3/4-inch-diameter studs and providing resilient rubber cushioning under the nuts, at the foundation-fastener interface, and at the rail flange-fastener interface. In addition, the intensity of stress cycling imposed on the stud is lessened by the fact that the motion of, and the forces from, the rail are somewhat absorbed by the lips of the steel hold-down plates before being passed on to the foundation studs.

The rubber interface between the rail flange and the fastener does double duty; it is also a means of insulating the rail from the foundation, which is desirable to simplify electric signaling, control, and propulsion circuits.

Fastener for Two-Headed Rail. Of the fasteners designed for the two-headed rail, the one shown in Figure 45 is recommended on the basis of simplicity and low cost. It consists of two pieces which sandwich the rail between them, preventing the rail from moving relative to the fastener. Each piece can be fabricated by bending, shearing, and forming out of 1/2-inch plate. The adjustment of the rail-fastener assembly relative to the foundation is done in the same manner as in the standard rail fastener: with shims and hexagonal eccentric sleeves. Again, installation of the foundation studs must be to within 1/2 inch of the intended initial alignment.

The rail is insulated electrically by a thin rubber interface between it and the fastener. The presence of this deformable interface also serves both to eliminate the need for accurate machining of the fastener to mate with the rail and to cushion the fastener and its clamping studs from fatigue.

This fastener assembly is more expensive and less compact than that for the standard rail, and the loading imposed on its components is more complex,

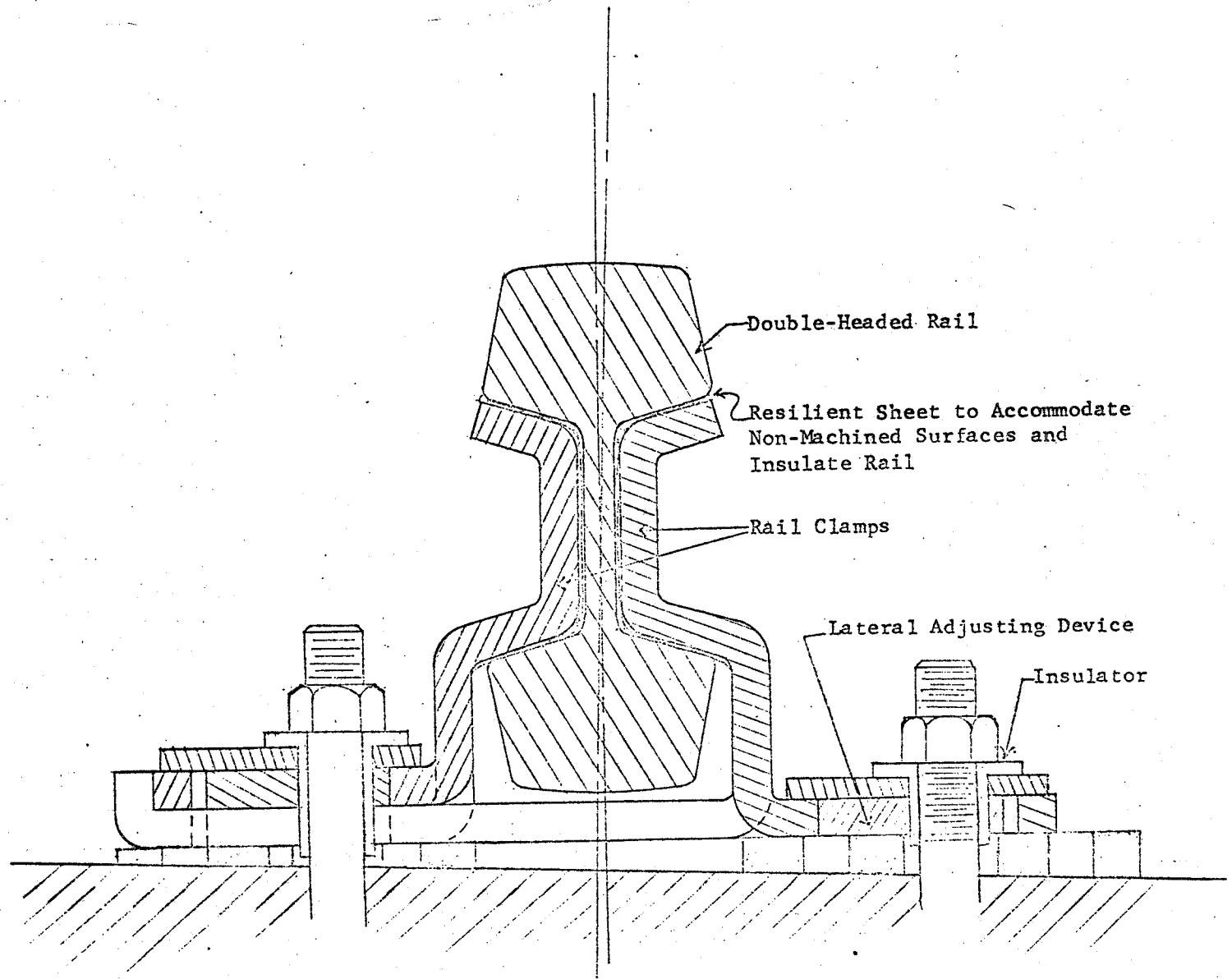

FIGURE 45. TWO-HEADED RAIL AND FASTENER

partly because the support is more roundabout (due to the incapability of supporting the rail on its lower head), and partly because the components are not symmetrical. However, it is expected to be more than strong enough and more than stable enough.

The fact that the load is transferred from the railhead directly to the fastener-support fixture eliminates high stress concentrations in the rail's web-head fillets and does a better job than the standard rail fastener in that respect.

Fatigue stresses in the foundation studs are also less critical because of the greater fastener mass that the force-path passes through that serves to decrease the amplitude of such stresses.

Fastener for Three-Headed Rail. A fastener for a three-headed rail is shown in Figure 46. It incorporates the same adjustment devices as the standard and two-headed rail fasteners do, but the support and hold-down is more straightforward. Vertical support is provided by a one-piece, extremely simple to fabricate, base plate. This same base provides most of the lateral support in both directions. Part of the lateral support and all of the hold-down is provided by two identical spring clips similar to the Swedish FIST type. These clips also serve to prevent the rail from rotating about its central support in a manner analogous to preventing a seesaw from moving by holding both ends down simultaneously. This antirotation function is performed by the hold-down plate of the standard rail fastener assembly also, but is more obvious and necessary in this three-headed rail fastener assembly because the support to the rail is neither broad nor flat and, therefore, is less stable than platform support. However, the support of the rail being directly beneath the load-carrying railhead results in a less circuitous force path than in the two-headed rail fastener support which, consequently, submits the support to much less complicated stresses.

As in the other fasteners, electrical insulation is effected by providing rubber interfaces between the rail and spring clips and between the rail and support base.

The most vulnerable fatigue zone in this assembly is the entire spring clip. Because they must be flexible enough to spread over the lower railheads at installation, and strong enough to hold the rail down indefinitely while in a combined static and dynamic stressed state, there is some question as to their fatigue endurance. This can only be satisfactorily resolved through detailed design and analysis, and finally a prototype test.

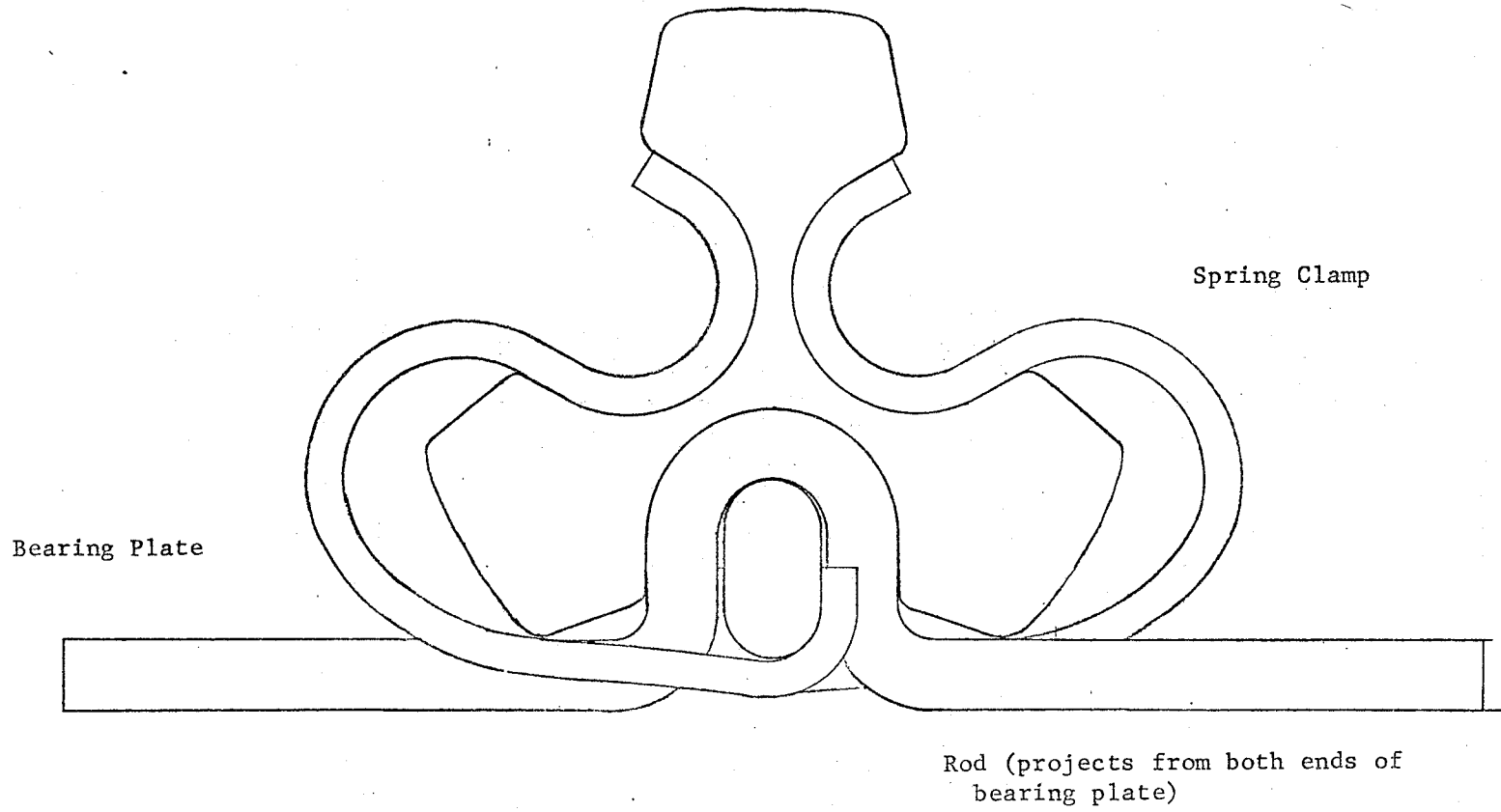

FIGURE 46. CONCEPT FOR THREE-HEADED RAIL AND ATTACHMENT DEVICE

REFERENCES

1. Request for Proposals No. C-111-66(Neg.), entitled: "Instrumentation, Measurement, Evaluation, and Simulation of the Dynamic Performance of High Speed Trains". (Attachment D) January 24, 1966.
2. Proceedings of the Thirty-Fifth Annual Convention of the AREA, Volume 35, 1934.
3. Birman, F., "Track Parameters, Static and Dynamic", paper presented at the Joint Convention on Interaction Between Vehicle and Track, London, England (November, 1965).
4. Matsudaira, T., "Dynamics of High Speed Rolling Stock", Japanese National Railway Quarterly Report (special issue).
5. Satoh, Y., and Ohtsuki, T., "The Allowable Limit of Lateral Pressure on Railway Track", Japanese National Railway Quarterly Report, 4 (3), (1963).
6. Heath, D.L. and Cottram, M., "Stresses Beneath a Railway Track", The Railway Gazette, (December 16, 1966).
7. Den Hartog, J.P., "Advanced Strength of Materials", McGraw-Hill Book Company, Inc., (1952), pp. 144-146.
8. Larew, H.G., and Leonards, G.A., "A Strength Criterion for Repeated Loads", Proceedings Highway Research Board 41 (1962) pp. 529-556.
9. Symposium on Dynamic Testing of Soils, ASTM Special Technical Publication No. 156, 1954.
10. Crockett, J.H.A., and Hammond, R.E.R., "The Dynamic Principles of Machine Foundations and Ground", Proceeds, Institute of Mechanical Engineering, London, 160 (1949).
11. Newcomb, W.K., "Principles of Foundation Design for Engines and Compressors", Trans. ASME, 73 (1951).
12. Frevert et. al., "Soil and Water Conservation Engineering", 2nd Ed., Wiley, 1966.
13. Lutlin, J.N., Editor, "Drainage of Agricultural Lands", Monograph No. 7, American Society of Agronomy, 1957.
14. Lutlin, J.N., "Drainage Engineering", Wiley, 1966.
15. Taylor, D.W., "Fundamentals of Soil Mechanics", Wiley, 1948.
16. Terzaghi and Peck, "Soil Mechanics in Engineering Practice", Wiley, 1948.
17. Cedergren, H.R., "Seepage Requirements of Filters and Pervious Bases", Proc. ASCE, 86, (Oct. 1960), SM 5.
18. Hetenyi, M., Beams on Elastic Foundations, University of Michigan Press (1946).
19. Timoshenko, S.P., "Method of Analysis of Statical and Dynamical Stresses in Rail", The Collected Papers of Stephen P. Timoshenko, McGraw-Hill Book Company, (1953), pp. 422-435.

REFERENCES (Continued)

20. Mathews, P.M., "Vibrations of a Beam on Elastic Foundation", Z. Angew. Math. Mech., Bd. 38 Nr. 3/4 Marz, (April 1958), pp. 105-115.
21. Kenney, J.T. Jr., "Steady-State Vibrations of Beam on Elastic Foundation for Moving Load", Journal of Applied Mechanics, (December, 1954), pp. 359-364.

APPENDIX A

DETAILED COST BREAKDOWN FOR FOUR RECOMMENDED  
BEAM STRUCTURES AND FOUR RECOMMENDED  
RAIL-FASTENER ASSEMBLIES





TWIN REINFORCED CONCRETE BEAMS

Forms--2 feet deep, continuous

$$2 \frac{\text{ft}^2}{\text{form-ft}} \times \frac{2 \text{ forms}}{\text{rail}} = 4 \text{ ft}^2/\text{rail-ft}$$

(1) Placing, removing, cleaning	at	\$1.17/ft <sup>2</sup>	:	4.0 x 1.17	=	\$4.68/rail-ft
(2) Chairs, spacers, etc.	at	0.30/rail-ft	:		=	0.30
(3) Added forms for cross-ties	at	1.17/ft <sup>2</sup>	:	0.15 x 1.17	=	0.18

Concrete--Volume = 2 ft x 1 ft x  $\frac{21.5}{12}$  = 3.58 ft<sup>3</sup>/rail-ft

Top area = 1 ft x  $\frac{21.5}{12}$  = 1.79 ft<sup>2</sup>/rail-ft

(1) Material and installation	at	\$1.85/ft <sup>3</sup>	:	3.58 x 1.85	=	\$6.63
(2) Finishing and curing	at	0.15/ft <sup>3</sup>	:	1.79 x 0.15	=	0.27
(3) Cross-ties	at	6% of installed beam cost	:		=	0.41

Reinforcing--41.75 lb/rail-ft + 6% for cross-ties = 44.25 lb/rail-ft

(1) Material, including 10% overlap	at	\$0.114/lb	:			
(2) Tying and placing cages	at	0.64/lb	:			
		<u>\$0.178/lb</u>	:	44.25 x 0.178	=	\$7.87

Rail Attach Inserts--cast in place at \$2.50/insert

$$4 \frac{\text{studs}}{\text{rail station}} \times \frac{1 \text{ station}}{3 \text{ ft}} \times \frac{1 \text{ insert}}{2 \text{ studs}} = 0.67 \text{ inserts/rail-ft} : 0.67 \times 2.50 = \$1.67$$

Excavation, Backfill, etc.

\$2.09

Total Cost of Structure = \$24.10/rail-ft  
or = \$254,000/track-mile

FASTENER FOR TWO-HEADED RAIL

Steel--rail, fixture, shims

- (1) Rail:  $A = 10.6 \text{ in.}^2$ , continuous at  $0.283 \text{ lb/in.}^3 \rightarrow 36.0 \text{ lb/rail-ft}$
- (2) Fixture:  $V = 136.0 \text{ in.}^3$ , 1 fixture/3 rail-ft  
 therefore,  $A = 3.78 \text{ in.}^2$ , continuous  $\rightarrow 12.8 \text{ lb/rail-ft}$
- (3) 1/2-inch shims:  $V = 72.0 \text{ in.}^3$ , 1 shim/3 rail-ft  
 therefore,  $A = 2.0 \text{ in.}^2$ , continuous  $\rightarrow 6.8 \text{ lb/rail-ft}$
- 55.6 lb/rail-ft at \$0.20/lb = \$11.10/rail-ft

Fastener Nuts--3 nuts/fixture x 1 fixture/3 rail-ft = 1 nut/rail-ft, installed at \$0.44/nut = 0.44/rail-ft

Neoprene--1/16-inch rail insulate and 0.4-inch vibration pad

A-2

- (1) Insulation:  $7.5 \text{ in.}^3/\text{fixture} \times 1 \text{ fixture}/3 \text{ rail-ft}$   
 $= 2.5 \text{ in.}^3/\text{rail-ft}$  at  $0.0464 \text{ lb/in.}^3 \rightarrow 0.116 \text{ lb/rail-ft}$
- (2) Pad:  $\frac{6}{7} \text{ pad/fixture} \times 1 \text{ fixture}/3 \text{ rail-ft}$   
 $= \frac{2}{7} \text{ pad/rail-ft}$  at  $2.2 \text{ lb/pad} \rightarrow \frac{0.629 \text{ lb/rail-ft}}{0.745 \text{ lb/rail-ft}} \text{ at } \$1.20 = \$0.89/\text{rail-ft}$
- \$12.43/rail-ft

$$\text{Cost} = 12.43 \frac{\$}{\text{rail-ft}} \times \frac{10,560 \text{ rail-ft}}{\text{track-mile}} = \$131,000/\text{track-mile.}$$

REINFORCED CONCRETE SLAB

Forms--2 feet deep, continuous

$$2 \frac{\text{ft}^2}{\text{form-ft}} \times \frac{1 \text{ form}}{\text{rail}} = 2 \text{ ft}^2/\text{rail-ft}$$

(1) Placing, removing, cleaning	at \$1.17/ft <sup>2</sup>	:	2 x 1.17	=	\$2.34/rail-ft
(2) Chairs, spacers, etc.	at 0.30/rail-ft			=	0.30

Concrete--Volume = 2 ft x 1 ft x  $\frac{43 \text{ in.}}{12 \text{ in.}}$  = 7.16 ft<sup>3</sup>/rail-ft

Top area =  $\frac{43 \text{ in.}}{12 \text{ in.}}$  x 1 = 3.58 ft<sup>2</sup>/rail-ft

(1) Material and installation	at \$1.85/ft <sup>3</sup>	:	1.85 x 7.16	=	13.25
(2) Finishing and curing	at 0.15/ft <sup>2</sup>	:	0.15 x 3.58	=	0.54

Reinforcing--72.5 lb/rail-ft including stirrups

(1) Material, including 10% overlap	at \$0.114/lb				
(2) Tying and placing cages	at 0.064/lb				
	$\frac{\$0.178}{\text{lb}}$	:	0.178 x 72.5	=	12.90

Rail-attach Inserts--cast in place, \$2.50/insert

$$\frac{4 \text{ studs}}{\text{rail-station}} \times \frac{1 \text{ station}}{3 \text{ ft}} \times \frac{1 \text{ insert}}{2 \text{ studs}} = 0.67 \text{ insert/rail-ft}$$

at \$2.50/insert : 2.50 x 0.67 = 1.67

Excavation, Backfill, etc.

= 2.09

Total Support-Structure Cost per Track Mile =  $\$33.09/\text{rail-ft} \times 10,560 \frac{\text{rail-ft}}{\text{track-mile}}$

= \$300,000/track mile

ENCAPSULATED RAIL

Steel Rail:

A = 13 in.<sup>2</sup>, continuous

at 0.283 lb/in.<sup>3</sup> → weight = 44.20 lb/rail-ft at \$0.20/lb = \$8.83/rail-ft

Neoprene: 13-inch wrap-around, continuous, 0.4-inch thick

1 pad = 14 x 12 x 0.4 inches: have 13/14 pad

at 2.2 lb/pad → weight = 2.04 lb/rail-ft at \$1.20/lb = \$2.45/rail-ft

WIRAND Concrete Grout:

A = 35.3 in.<sup>2</sup> rail

at \$0.08/in.<sup>2</sup>/ft = \$2.82/rail-ft

Total Cost of Fixture Installed = \$14.10/rail-ft

or = \$149,000/rail-ft

STEEL-CONCRETE COMPOSITE--TWO BEAMS

Forms--2 feet deep, continuous

$$2 \frac{\text{ft}^2}{\text{form-ft}} \times \frac{2 \text{ forms}}{\text{rail}} = 4 \text{ ft}^2 \text{ rail-ft}$$

(1) Placing, removing, cleaning	at \$1.17/ft <sup>2</sup>	:	4.0 x 1.17	= \$4.68/rail-ft
(2) Chairs, spacers, etc.	at 0.30/rail-ft	:		0.30

Concrete--Volume = 2.98 ft<sup>3</sup>/rail-ft  
Top area = 1.79 ft<sup>2</sup>/rail-ft

(1) Material and installation	at \$1.85/ft <sup>3</sup>	:	1.85 x 2.98	= \$5.52
(2) Finishing and curing	at 0.15/ft <sup>2</sup>	:	0.15 x 1.79	= 0.27

Steel WF--16 WF 78 lb : 78 lb/rail-ft

at \$0.20/lb	:	0.20 x 78	= \$15.60	
at 0.25/lb	:			(0.25 x 78 = \$19.50)

Welded 3/4-inch Studs

(1) Top: rail attachment to 4-inch studs

$$\frac{4 \text{ studs}}{\text{rail-station}} \times \frac{1 \text{ station}}{3 \text{ ft}} = \frac{1.33 \text{ studs}}{\text{rail-ft}} \quad \text{at } \$0.30/\text{stud} \quad : \quad 0.30 \times 1.33 = \$0.40$$

(2) Bottom: 2-inch shear connection

$$\frac{2 \text{ studs}}{\text{rail-station}} \times \frac{1 \text{ station}}{3 \text{ ft}} = \frac{0.67 \text{ studs}}{\text{rail-ft}} \quad \text{at } \$0.20/\text{stud} \quad : \quad 0.67 \times 0.20 = \$0.13$$

Excavation, Backfill, etc.

$$\text{at } \$4.58/\text{track-ft} \quad = \underline{\$2.29}$$

$$\text{Total Support-Structure Cost per Track/mile} = \$29.19/\text{rail-ft} \times \frac{10,560 \text{ rail-ft}}{\text{track}}$$

$$= \$308,500/\text{track-mile}$$

(Note: For steel at \$0.25/lb add \$41,200/track-mile, then total cost = \$349,700/track-mile.)

FASTENER FOR STANDARD 133-POUND RAIL

Steel--rail, fixture, shims

- (1) Rail: 133 lb/rail-yd x 1 yd/3 ft = 44.25 lb/rail-ft  
(2) Fixture: 126 in.<sup>3</sup>/fixture x 1 fixture/3 rail-ft x 0.283 lb/in.<sup>3</sup> = 11.90 lb/rail-ft  
(3) 1/2-inch Shim: 90 in.<sup>3</sup>/fixture x 1 fixture/3 rail-ft x 0.283 lb/in.<sup>3</sup> = 8.48 lb/rail-ft  
64.63 lb/rail-ft at \$0.20/lb = \$12.92/rail-ft

Fastener Nuts--4 nuts/fixture x 1 fixture/3 rail-ft = 1.33 nuts/rail/ft at \$0.44/nut = \$0.59/rail-ft

Neoprene--1/16-inch rail insulate and 0.4-inch vibration padding

- (1) Insulation: 9 in.<sup>3</sup>/fixture x 1 fixture/3 rail-ft x 0.0464 lb/in.<sup>3</sup> = 0.139 lb/rail-ft  
(2) Padding: 1 pad/fixture x 1 fixture/3 rail-ft x 2.2 lb/pad = 0.734 lb/rail-ft  
0.873 lb/rail-ft at \$1.20/lb = \$1.05 rail-ft  
\$14.56/rail-ft

Cost = \$14.56/rail-ft x 10,500 rail-ft/track-mile = \$153,600 track/mile

TWIN STEEL BEAMS--SMALLER I

<u>Steel Beam</u> (I = 1020 in. <sup>4</sup> )	at	\$0.20/lb			
Area = 26.2 $\frac{\text{in.}^2}{\text{rail}}$ ; weight = 26.2 $\frac{\text{in.}^2}{\text{rail}}$ x 12 $\frac{\text{in.}}{\text{ft}}$ x 0.283 $\frac{\text{lb}}{\text{in.}^3}$	=	89.0 lb/rail-ft	x	0.20	= \$17.80/rail-ft
<u>Cross-Ties</u> --spaced 20 feet apart	at	6% of installed steel beam cost			= 1.06
<u>Corrosion Protection</u>	at	5% of installed steel cost			= 0.89
<u>Welded 3/4-inch x 3-inch Studs</u>	at	\$0.30/stud			
Top: rail attach = 4 $\frac{\text{studs}}{\text{station}}$ x $\frac{1 \text{ station}}{3 \text{ rail-ft}}$	=	1.33 studs/rail-ft	x	0.30	= 0.40
Bottom: concrete attach = 2 $\frac{\text{studs}}{\text{station}}$	=	0.67 studs/rail-ft	x	0.30	= 0.20
<u>Grout</u> --3-inch deep x 2-foot wide concrete	at	\$50/yd <sup>3</sup>			
Volume per rail-ft = (1/2 x 2 x 1) ft <sup>2</sup> x $\frac{1 \text{ yd}^3}{27 \text{ ft}^3}$	=	0.0185 yd <sup>3</sup> /rail-ft	x	50.00	= 0.93
<u>Forms</u> --4-inch deep, continuous	at	\$1.17 ft <sup>2</sup> , install and remove			
$\frac{1}{3} \frac{\text{ft}^2}{\text{form-ft}}$ x 2 $\frac{\text{forms}}{\text{rail}}$	=	0.67 ft <sup>2</sup> /rail-ft	x	1.17	= 0.78
<u>Excavation, Backfill, etc.</u>					= 2.29
Total cost of support structure, material, and installation = \$25.24/rail-ft					
					x 10,560 rail-ft/track-mile = \$266,500/track-mile

A-7

(Note: If steel cost is \$0.25/lb, add \$49,700/track-mile to get total cost of \$306,700/track-mile)



TWIN STEEL BEAMS--LARGER I

Steel Beam (I = 1500 in.<sup>4</sup>) at \$0.20/lb

$$\text{Area} = 28 \frac{\text{in.}^2}{\text{rail}}; \text{ weight} = 28 \frac{\text{in.}^2}{\text{rail}} \times 12 \frac{\text{in.}}{\text{ft}} \times 0.283 \frac{\text{lb}}{\text{in.}^3} = 95.0 \text{ lb/rail-ft} \times 0.20 = \$19.00/\text{rail-ft}$$

Cross-Ties--spaced 20 feet apart at 6% of installed steel beam cost = 1.14

Corrosion Protection at 5% of installed steel cost = 0.95

Welded 3/4-inch x 3-inch Studs at \$0.30/stud

$$\text{Top: rail attach} = 4 \frac{\text{studs}}{\text{station}} \times \frac{1 \text{ station}}{3 \text{ rail-ft}} = 1.33 \text{ studs/rail-ft} \times 0.30 = 0.40$$

$$\text{Bottom: concrete attach} = 2 \frac{\text{studs}}{\text{station}} = 0.67 \text{ studs/rail-ft} \times 0.30 = 0.20$$

Grout--3-inch deep x 2-foot wide concrete at \$50/yd<sup>3</sup>

$$\text{Volume per rail-ft} = (1/4 \times 2 \times 1) \text{ ft}^3 \times \frac{1 \text{ yd}^3}{27 \text{ ft}^3} = 0.0185 \text{ yd}^3/\text{rail-ft} \times 50.00 = 0.93$$

Forms--4-inch deep, continuous at \$1.17/ft<sup>2</sup>, install and remove

$$1/3 \frac{\text{ft}^2}{\text{form-ft}} \times 2 \frac{\text{forms}}{\text{rail}} = 0.67 \text{ ft}^2/\text{rail ft} \times 1.17 = 0.78$$

Excavation, Backfill, etc. = 2.29

Total cost of support structure, material, and installation = \$25.69/rail-ft  
 x 10,560 rail-ft/track-mile = \$271,500/track-mile

(Note: If steel cost is \$0.25/lb, add \$55,700/track mile to get total cost of \$327,200-track-mile)

A-8

FASTENER FOR REPLACEABLE-HEAD RAIL

Steel--rail, fixture, shims

Rail:	$A = 4.4 \text{ in.}^2$ , continuous at 0.283 lb/in. <sup>3</sup>	→ 14.94 lb/rail-ft
Fixture:	$A = 16.1 \text{ in.}^2$ , continuous	→ 57.10 lb/rail-ft
1/2-inch Shim:	$\frac{8 \times 1/2 \text{ inch} \times 1 \text{ foot long}}{\text{rail-station}} \times \frac{1 \text{ station}}{6 \text{ ft}} = 8 \text{ in.}^4/\text{rail-ft}$	→ 2.26 lb/rail-ft
		<u>74.30 lb/rail-ft at \$0.20/lb = \$14.86/rail-ft</u>

Head Bolt, nut washer--1 bolt/2 rail-ft (installed) at 0.64/bolt = 0.32

Fastener nuts-- 4 nuts/station x 1 station/6 ft = 0.67 nuts/rail-ft (installed) at 0.44/nut = 0.29

Neoprene--1/16-inch rail insulate and 0.4-inch vibration pad

Insulation:	continuous, $5 \times 1/16 \times 12 \text{ in./ft} \times 0.464 \text{ lb/in.}^3$	= 0.174 lb/rail-ft
Vibration pad:	$2.2 \text{ lb/pad} \times \frac{4}{7} \frac{\text{pad}}{\text{station}} \times \frac{1 \text{ station}}{6 \text{ ft}}$	= 0.210 lb/rail-ft
		<u>0.394 lb/rail-ft at 1.20/lb = 0.47</u>
		<u>\$15.94/rail-ft</u>

Total Cost =  $\$15.94/\text{rail-ft} \times 10,560 \frac{\text{rail-ft}}{\text{track-mile}} = \$168,200/\text{track-mile}$

(Note: If steel costs \$0.25/lb, add \$39,200/mile to get total cost of \$207,400.)



APPENDIX B

CALCULATION OF STRESSES IN  
STEEL-CONCRETE COMPOSITE  
BEAM TRACK STRUCTURE



APPENDIX B

CALCULATION OF STRESSES IN  
STEEL-CONCRETE COMPOSITE  
BEAM TRACK STRUCTURE

To calculate the stiffness and stresses for the beam shown in Figure B-1(a), the location of the neutral axis (N) must first be determined. This is done by generating an all-steel equivalent beam by reducing the area of concrete in compression by an amount proportional to the ratio of the elastic moduli of steel and concrete (assumed to be 10). The concrete in tension contributes no strength or stiffness. The neutral axis is located at the centroid of this all-steel equivalent beam, and can be found by the following equation:

$$2.15(N) \left(\frac{N}{2}\right) + 3.31(N-2.6) = 6.63(17.7 + 2.6-N)$$

or 
$$1.075 N^2 + 9.94 N - 144 = 0 .$$

Solving for N yields

$$N = 7.82 \text{ in.}$$

The moment of inertia of this all-steel equivalent beam is

$$I_S = 3.31(7.82 - 2.6)^2 + 6.63(17.7 + 2.6 - 7.82)^2 + \frac{1}{3} (2.15)(7.82)^3$$

$$I_S = 1500 \text{ in.}^4$$

For a positive bending moment of 625,000 in.-lb, the tensile stress in the steel is

$$\sigma_{ST} = \frac{625,000(12.5)}{1500}$$

$$\sigma_{ST} = 5200 \text{ psi (29 percent of allowable 18,000).}$$

The compressive stress in the concrete for this same bending moment is

$$\sigma_{CON} = \frac{625,000(7.82)}{1500(10)}$$

$$\sigma_{CON} = 326 \text{ psi (29 percent of allowable 1,140 psi).}$$

For negative bending moments, the location of the neutral axis changes. Figure B-1(b) shows the all-steel equivalent beam for this case and the location of the neutral axis (n) can be found in the same manner as for positive bending moments

$$2.15N \left( \frac{n}{2} \right) + 6.63(N-3) = 3.31(17.7 + 3-n)$$

which yields

$$n = 5.72 \text{ in.}$$

The moment of inertia of the all-steel equivalent beam about its neutral axis is

$$I_S = 6.63(5.72 - 3)^2 + 3.31(17.7 + 3 - 5.72)^2 + \frac{1}{3} (2.15)(5.72)^3$$

or  $I_S = 928 \text{ in.}^4$

The maximum stress in the steel due to a negative bending moment of 325,000 in.-lb is

$$\sigma_{ST} = \frac{325,000(15.0)}{928}$$

or  $\sigma_{ST} = 5350 \text{ psi (30 percent of allowable 18,000).}$

The maximum compressive stress in the concrete is

$$\sigma_{CON} = \frac{325,000(5.72)}{928(10)}$$

$\sigma_{CON} = 201 \text{ psi (18 percent of allowable 1,140).}$

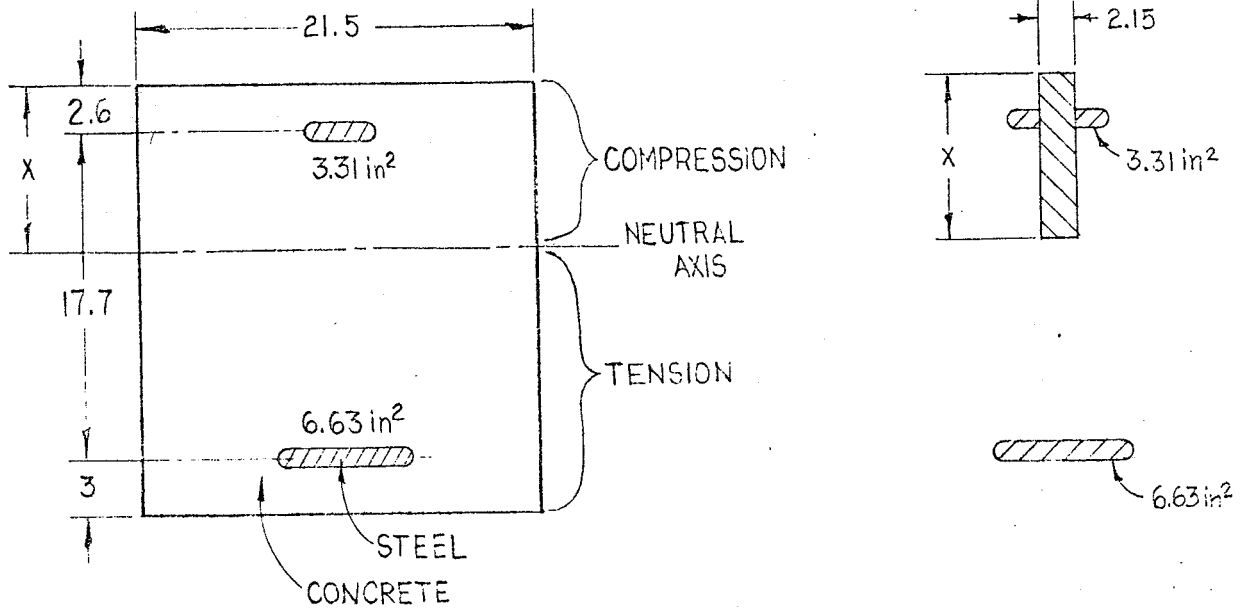

(a) Positive Bending

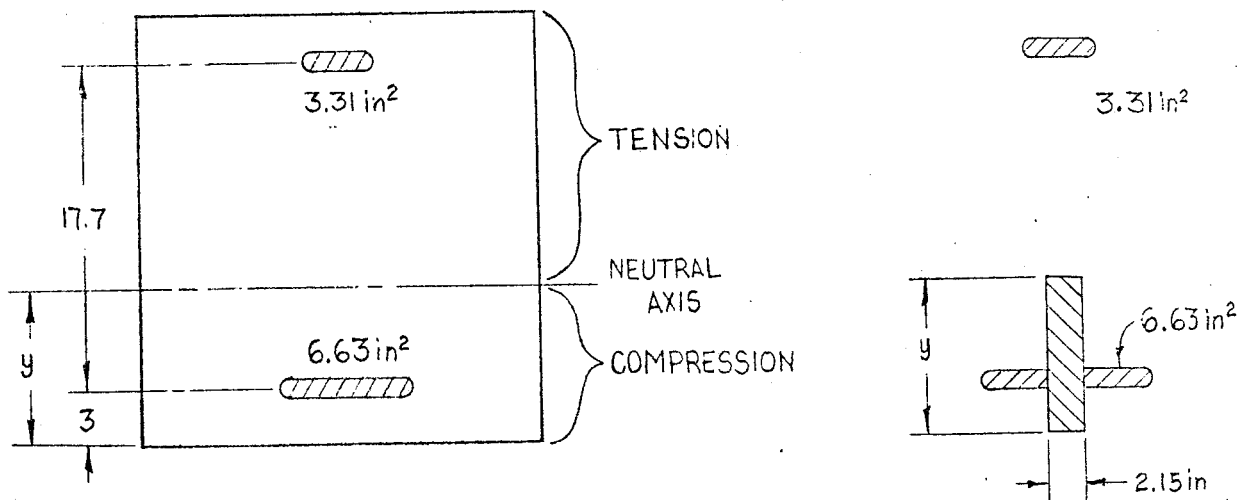

(b) Negative Bending

FIGURE B-1. CONVERTING A COMPOSITE BEAM INTO AN ALL-STEEL BEAM





SUMMARY REPORT

on

STUDY OF NEW TRACK STRUCTURE DESIGNS  
PHASE II

to

UNITED STATES DEPARTMENT OF TRANSPORTATION

February 28, 1969

by

H. C. Meacham, J. E. Voorhees,  
G. J. Eggert, and J. J. Enright

BATTELLE MEMORIAL INSTITUTE  
Columbus Laboratories  
505 King Avenue  
Columbus, Ohio 43201

