

Report No. FRA/ORD-77/35

U. S. -U. S. S. R. RAIL INSPECTION
INFORMATION EXCHANGE

F. L. Becker

Battelle Pacific Northwest Laboratories
Richland WA 99352



JUNE 1977

FINAL REPORT

DOCUMENT IS AVAILABLE TO THE U.S. PUBLIC
THROUGH THE NATIONAL TECHNICAL
INFORMATION SERVICE, SPRINGFIELD,
VIRGINIA 22161

Prepared for
U.S. DEPARTMENT OF TRANSPORTATION
FEDERAL RAILROAD ADMINISTRATION
Office of Research and Development
Washington DC 20590

NOTICE

This document is disseminated under the sponsorship of the Department of Transportation in the interest of information exchange. The United States Government assumes no liability for its contents or use thereof.

NOTICE

The United States Government does not endorse products or manufacturers. Trade or manufacturers' names appear herein solely because they are considered essential to the object of this report.

Technical Report Documentation Page

1. Report No. FRA/ORD-77/35		2. Government Accession No.		3. Recipient's Catalog No.	
4. Title and Subtitle U.S.-U.S.S.R. RAIL INSPECTION INFORMATION EXCHANGE		5. Report Date JUNE 1977		6. Performing Organization Code	
		7. Author(s) F. L. Becker		8. Performing Organization Report No. DOT-TSC-FRA 77-6	
9. Performing Organization Name and Address Battelle Pacific Northwest Laboratories* Richland WA 99352		10. Work Unit No. (TRAIS) RR731/R7314		11. Contract or Grant No. DOT-TSC-979	
		12. Sponsoring Agency Name and Address U.S. Department of Transportation Federal Railroad Administration Office of Research and Development Washington DC 20590		13. Type of Report and Period Covered Final Report August 1975-September 1975	
14. Sponsoring Agency Code		15. Supplementary Notes U.S. Department of Transportation Transportation Systems Center *Under contract to: Kendall Square Cambridge MA 02142			
16. Abstract This trip report describes the results and conclusions of the U.S. delegation resulting from the U.S.-U.S.S.R. Rail Inspection Information exchange tour of the Soviet Union, August 24 through September 1, 1975. This information exchange was conducted under protocol agreements developed in 1974 between the Ministry of Railroads of the U.S.S.R. and the Federal Railroad Administration of the U.S. Department of Transportation. The objective of this information exchange was to achieve a technical description of Soviet rail inspection technology and practice and to learn of recent R&D efforts for nondestructive inspection (NDI) of rail. The pertinent areas included: contemporary rail NDI systems, planning and scheduling of rail inspection, inspection of track components other than rail, methods for measurement of rail stresses, and recent R&D efforts in rail NDI. This report is divided into five sections: itinerary, description of devices and techniques, applicability of Soviet technology to U.S. rail NDI, effectiveness of the information exchange, and recommendations for future exchanges. The itinerary section of the report lists the facilities and personnel contacted, and relates the content of the technical discussions that took place. The equipment section of the report describes the devices and techniques that were discussed. A critical review of the applicability of Soviet technology to U.S. rail NDI and the effectiveness of the information exchange are contained in the following two sections of the report. The concluding section lists the recommendations for future exchanges based on the experiences of this delegation.					
17. Key Words Track, Flaw, Ultrasonics, Magnetic, Rail, Nondestructive Testing			18. Distribution Statement DOCUMENT IS AVAILABLE TO THE U.S. PUBLIC THROUGH THE NATIONAL TECHNICAL INFORMATION SERVICE, SPRINGFIELD, VIRGINIA 22161		
19. Security Classif. (of this report) Unclassified		20. Security Classif. (of this page) Unclassified		21. No. of Pages 86	22. Price

SUMMARY

From August 24 to September 1, 1975, a team of American railroad researchers visited the Soviet Union, as part of an information-exchange program worked out in 1974 between the U.S. Federal Railroad Administration and the Ministry of Railroads of the U.S.S.R. The purpose of the visit was to find out and discuss Soviet practice and research in the field of nondestructive inspection (NDI) of rail.

Eight facilities in three cities, Moscow, Leningrad and Kishinyev, were visited during the trip. The facilities included: Ministry of Railroads; Shcherbinka Test Loop; All-Union Railway Research Institute in Moscow; Leningrad Railway Engineer Training-Bridge Research Institute; October Railroad in Leningrad; and Odessa-Kishinyev Railroad and Rail Welding Plant at Golta (near Pervomaysk). These visits and discussions resulted in an overview of the organizational structure and its operation within the track service department. Current practice as applied to the field of rail inspection was also described and demonstrated by the Soviet hosts.

The 26 railroads composing the Soviet rail system are under the direction of the Ministry of Railroads. The track service departments of the ministry and the individual railroads are responsible for the maintenance, renewal, installation and NDI of all track. The department is subdivided into five levels: Ministry, individual railroads, districts, line intersections, and section work gangs. Each railroad is divided into 3 to 15 districts, each of which contains 3 to 5 line intersections. A line intersection normally contains 200 to 300 km of track. The section work gangs are responsible for 8 to 10 km of track and report to the road master, who is responsible for 2 or 3 work gangs. Rail NDI and geometry measurements are conducted by each level of the organizational structure. The primary responsibility for these inspections rests with the line intersection personnel, whose work is systematically checked over by the district, railroad and ministry.

The primary rail NDI is performed by the line intersection crew using ultrasonic carts that are pushed along the rails. This inspection requires two inspectors and is performed three to four times a month. The carts can cover 6 to 8 km per day. Of the 4 carts that we saw, only one, the UZD-NIIM-6M, could detect both longitudinal and transverse defects. The older, less effective units are still used because there are not enough of the newer models.

The primary rail-geometry measurements are made weekly by the section foreman using manual gages, and bi-weekly by the roadmaster and section foreman using a pushcart device. The track is also inspected visually each day by a section member and monthly by the line intersection chief engineer.

The railroad or the ministry checks rail NDI inspections approximately once a month using high-speed (up to 100 km/hr or 60 mph) ultrasonic and magnetic inspection cars. The ultrasonic cars (there are only four) are in many respects similar to those used in Germany and England, except that fewer search units are used and therefore less effective overall performance would be expected. The magnetic cars are substantially different from those used in the U.S. The Soviet magnetic car is based on the principle that a rapidly moving magnetic field generates eddy currents in the rail. The perturbation of these currents by a transverse defect is detected by a single coil placed on the rail between the poles of the magnet. The car operates at 100 km/hr (60 mph); however, it can only detect relatively large transverse defects within 4 mm (0.16 in.) of the rail surface.

The railroad or ministry inspects track geometry once per month using a 100-km/hr (60 mph) car. This car uses contact shoes and wheels linked by cables to the recorder and is relatively unsophisticated by U.S. standards.

While at the Shcherbinka Test Loop we discussed the operation of the facility and some of the research performed there.

The facility consists of three test loops of 5.7, 5.7, 6.0 km with approximately 18 km of auxiliary track. The outer, 6-km, loop is used to test locomotives and rolling stock. The inner two 5.7-km loops are used to test and evaluate rails, ties, fasteners and construction techniques. Accelerated rail life is tested by means of an 8,500-ton train made up of 4-, 6- and 8-axle cars. The inner two loops accumulate 1.2 million gross tons each night or approximately 400 million gross tons per year. All new designs of rolling stock, rails, ties, fasteners, construction methods and rail NDI equipment must first be tested at Shcherbinka before they can be put into service.

As a result of testing at Shcherbinka a large body of rail failure and flaw growth rate data has been accumulated. These data should be useful and informative even if not directly applicable to conditions encountered in the U.S.--the principal difference being the lower maximum axle loads allowed in the U.S.S.R. An ultrasonic flaw profiling device, which is used in flaw growth rate studies, was demonstrated for the delegation. The Soviets claimed that this device could define the actual size of rail flaws with an accuracy of $\pm 3\%$. A device of this type would be useful for U.S. studies of flaw growth rate.

Strain-gage methods are the only techniques used in the Soviet Union for the measurement of stress in rails. Measurement of rail-surface temperature is the only method used to evaluate stress conditions in continuous welded rail during installation and repair.

The application of Soviet technology to U.S. rail inspections is limited by the differences in the two systems. For example, the use of pushcart inspections is considered prohibitively expensive for U.S. applications. Several ultrasonic techniques used in the U.S.S.R. appear to be highly successful. These techniques should be further investigated to determine their effectiveness under U.S. rail conditions. In the area of rail geometry measurements, the Soviets could gain considerable information from the more sophisticated U.S. systems.

The overall effectiveness of this exchange did not meet our full expectations, although we obtained valuable information. The principal area limiting the effectiveness of the trip was the lack of information on current research-and-development programs. We were particularly disappointed by our inability to obtain information on electromagnetic acoustic (EMAC) rail inspection. We were told that the groups developing this inspection method were not under the jurisdiction of the Ministry of Railroads and that meetings could not be arranged.

PREFACE

This report presents information on the nondestructive inspection techniques and equipment used to inspect railroad track components in the U.S.S.R. The information was obtained as a result of a visit of a U.S. Delegation of specialists to the U.S.S.R. in August 1975. The visit was part of a continuing information exchange between the two countries in accordance with relevant protocol agreements developed in 1974 between the Ministry of Railroads of the U.S.S.R. and the Federal Railroad Administration of the U.S. Department of Transportation.

The author would like to acknowledge the contributions of several individuals to the preparation of this report. The comments and assistance of delegation members H. L. Ceccon, Transportation Systems Center, D. E. Bray, University of Oklahoma, and R. M. Owen, Sperry Rail Service, have been very helpful. G. J. Posakony and L. O. Foley of Battelle-Northwest assisted in editing and preparing this report. M. K. Harmon of Richland, Washington and Bob Karriker of Norman, Oklahoma translated selected portions of Soviet documents.

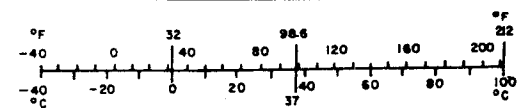
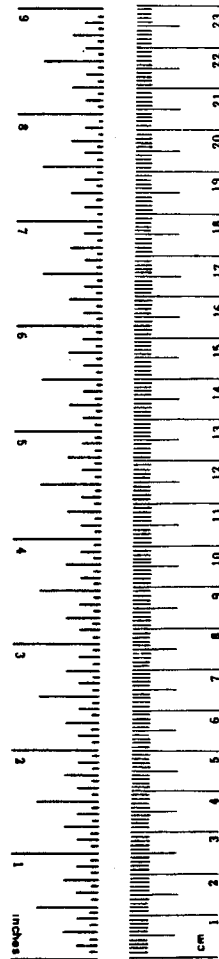
METRIC CONVERSION FACTORS

Approximate Conversions to Metric Measures

Symbol	When You Know	Multiply by	To Find	Symbol
LENGTH				
in	inches	2.5	centimeters	cm
ft	feet	30	centimeters	cm
yd	yards	0.9	meters	m
mi	miles	1.6	kilometers	km
AREA				
in ²	square inches	6.5	square centimeters	cm ²
ft ²	square feet	0.09	square meters	m ²
yd ²	square yards	0.8	square meters	m ²
mi ²	square miles	2.6	square kilometers	km ²
	acres	0.4	hectares	ha
MASS (weight)				
oz	ounces	28	grams	g
lb	pounds	0.45	kilograms	kg
	short tons (2000 lb)	0.9	tonnes	t
VOLUME				
tsp	teaspoons	5	milliliters	ml
Tbsp	tablespoons	15	milliliters	ml
fl oz	fluid ounces	30	milliliters	ml
c	cups	0.24	liters	l
pt	pints	0.47	liters	l
qt	quarts	0.95	liters	l
gal	gallons	3.8	liters	l
ft ³	cubic feet	0.03	cubic meters	m ³
yd ³	cubic yards	0.76	cubic meters	m ³
TEMPERATURE (exact)				
°F	Fahrenheit temperature	5/9 (after subtracting 32)	Celsius temperature	°C

Approximate Conversions from Metric Measures

Symbol	When You Know	Multiply by	To Find	Symbol
LENGTH				
mm	millimeters	0.04	inches	in
cm	centimeters	0.4	inches	in
m	meters	3.3	feet	ft
m	meters	1.1	yards	yd
km	kilometers	0.6	miles	mi
AREA				
cm ²	square centimeters	0.16	square inches	in ²
m ²	square meters	1.2	square yards	yd ²
km ²	square kilometers	0.4	square miles	mi ²
ha	hectares (10,000 m ²)	2.5	acres	
MASS (weight)				
g	grams	0.035	ounces	oz
kg	kilograms	2.2	pounds	lb
t	tonnes (1000 kg)	1.1	short tons	
VOLUME				
ml	milliliters	0.03	fluid ounces	fl oz
l	liters	2.1	pints	pt
l	liters	1.06	quarts	qt
l	liters	0.26	gallons	gal
m ³	cubic meters	35	cubic feet	ft ³
m ³	cubic meters	1.3	cubic yards	yd ³
TEMPERATURE (exact)				
°C	Celsius temperature	9/5 (then add 32)	Fahrenheit temperature	°F



CONTENTS

<u>Section</u>	<u>Page</u>
INTRODUCTION	1
ITINERARY AND TECHNICAL DISCUSSIONS	2
Monday, August 25, 1975, Moscow	2
Ministry of Railroads	2
Shcherbinka Test Loop	5
All-Union Railway Research Institute (TSNII)	9
Tuesday, Wednesday, August 26, 27, 1975, Leningrad	11
Leningrad Railway Engineer Training and Bridge Research Institute	11
October Railroad	13
Thursday, Friday, August 28, 29, 1975, Kishinyev	15
Odessa Kishinyev Railroad	15
Rail-welding Plant	18
Monday, September 1, Moscow	19
Rail Transport Ministry	19
EQUIPMENT AND TECHNIQUES	22
Ultrasonic Methods	22
Ultrasonic Inspection Car	22
UZD-NIIM-6M Ultrasonic Rail Inspection Cart	30
URD-58 and -58M Ultrasonic Rail Inspection Cart	33
DUK-131M Ultrasonic Rail Weld Inspection Device	34
UDM-1M Defectoscope	35
Ultrasonic Flaw Profiling Instrument	39
Magnetic Methods	42
High Speed Magnetic Inspection Car	42
MRD-66 Magnetic Flaw Detection Cart	45
Geometry Inspection	45
High Speed Track Geometry Measurement Car	45
Track Geometry Measurement Cart	47
Electromagnetic Acoustic Technology	47

CONTENTS (Concl'd)

<u>Section</u>	<u>Page</u>
APPLICABILITY OF SOVIET RAIL TESTING TECHNOLOGY FOR U.S. APPLICATION	53
Magnetic Inspection Car	54
Ultrasonic Inspection Car	54
Other Ultrasonic Techniques	55
Geometry Measurements	56
EFFECTIVENESS OF EXCHANGE	57
RECOMMENDATIONS FOR FUTURE EXCHANGES	58
REFERENCES	59
APPENDIX: Selected Translations of Soviet Documents	64

ILLUSTRATIONS

<u>Figure</u>		<u>Page</u>
1	U.S.-U.S.S.R. delegations at the Ministry of Railroads. Personnel from left to right are: Professor Albrekht, Mr. Stateynov, Mr. Owen, Mr. Kolodyazhnyi, Mr. Belov, Mr. Chernysh, Mr. Ceccon, Mr. Pashinin, Mr. Bray, Mr. Alexandrov, and Mr. Becker	3
2	Sample schedule for nondestructive rail inspection for a typical line intersection of the Odessa-Kishinyev Railroad.	6
3	Growth rate of detail fracture type cracks in R-65 rail as a function of the number of cyclic loadings at loads of (1) 15 tons, (2) 12.5 tons and (3) 10 tons. Curves 4 and 5 relate to the growth rate as it would apply for (4) grades and (5) level areas. The crack size listed is the percentage of head area.	8
4	U.S.-U.S.S.R. delegations at TSNII; personnel from left to right are: Professor Albrekht, Mr. Lysenko, Mr. Bray, Mr. Becker, Mr. Ceccon, Mr. Karetnikov, Mr. Owen, Mr. Lukov, and Mr. Belov.	10
5	U.S.-U.S.S.R. delegations at the Leningrad Railway Engineer Training Institute. Personnel from left to right are: Dr. Silnitski, Mr. Goorvich, Mr. Becker, Mr. Owen, Mr. Ceccon, Professor Dr. Kraskovski, Mr. Bray, Professor Dr. Philpov, Dr. Volokov, Mr. Shabalin and Mr. Yatzuk.	12
6	Typical detail fracture.	16
7	Typical transverse fissure.	16
8	Strain gage device for the measurement of stress in rails.	21
9	Carriage assembly of the ultrasonic inspection car.	23
10	Transducer assemblies used on the ultrasonic car.	25
11	Skew angle beam technique. Incident angle $\alpha = 60^\circ$ skew angle $\gamma = 30^\circ$.	26

<u>Figure</u>	ILLUSTRATIONS (Concl'd)	<u>Page</u>
12	Electronic equipment racks of the ultrasonic inspection car.	28
13	Four-pen stripchart recorder for recording test data.	29
14	The UZD-NIIM-6M ultrasonic inspection cart.	31
15	Design of the ultrasonic caliper and responses from (1) a sound, and (2) a cracked bolt hole.	32
16	Rail weld scanning procedure.	36
17	Typical rail weld defects: (1) silicate inclusions, (2) overburning, (3) slag inclusions, (4) porosity.	37
18	Signal responses from the UDM-1M for normal and defective head conditions.	38
19	Ultrasonic flaw profiler mounted on a defective rail.	40
20	Sketch of detail fracture in rail. True nature of defect was revealed by breaking rail.	41
21	Magnetic car defect indications from (1), (2) and (3) surface condition such as burns, chips and shells and (4), (5) and (6) transverse defects.	44
22	Schematic diagram of MRD-66 magnetic rail inspection cart.	46
23	Geometry measurement cart.	48
24	Schematic representation of cophasal shear wave generation by an EMAC transducer. Shear waves generated by each half of coil are in phase.	50

INTRODUCTION

This trip report describes the results and conclusions of the U.S. delegation resulting from the U.S. - U.S.S.R. Rail Inspection Information exchange tour of the Soviet Union, August 24 through September 1, 1975. This information exchange was conducted under protocol agreements developed in 1974 between the Ministry of Railroads of the U.S.S.R. and the Federal Railroad Administration of the U.S. Department of Transportation. Delegation members included:

H.L. Ceccon, Chairman, Transportation Systems Center,
Department of Transportation

F.L. Becker, Battelle-Northwest

D.E. Bray, University of Oklahoma

R.M. Owen, Sperry Rail Service

The objectives of this information exchange were to achieve a technical description of Soviet rail inspection technology and practice and to learn of recent R & D efforts for nondestructive inspection (NDI) of rail. The pertinent areas included contemporary rail NDI systems, planning and scheduling of rail inspection, inspection of track components other than rail, methods for measurement of rail stresses, and recent R & D efforts in rail NDI.

This trip followed an earlier visit by a delegation of officials from U.S. railroads, headed by Mr. W. B. O'Sullivan of the Federal Railroad Administration. The earlier visit concerned all phases of track matters while ours concentrated mainly on inspection. Future exchanges are planned for discussions concerning track systems, rail materials and processes.

The report is divided into five sections: itinerary, description of devices and techniques, applicability of Soviet technology to U.S. rail NDI, effectiveness of the information exchange, and recommendations for future exchanges. The itinerary section of the report lists the facilities and personnel contacted, and relates the content of the technical discussions that took place. The equipment section of the report describes the devices and techniques that were discussed. A critical review of the applicability of Soviet technology to U.S. rail NDI and the effectiveness of the information exchange is contained in the following two sections of the report. The concluding section lists the recommendations for future exchanges based on the experiences of this delegation.

During this information exchange, the U.S. delegation received 14 books and documents, ⁽¹⁻¹⁴⁾ all of which are in Russian. The translated titles, abstracts, introduction and table of contents are listed in the Appendix of this report. Several of these publications are currently being translated and should be available to the public in the near future.

ITINERARY AND TECHNICAL DISCUSSIONS

MONDAY, AUGUST 25, 1975, MOSCOW

Ministry of Railroads

The first official meeting of this exchange took place at the Ministry of Railroads building in Moscow. Present at this meeting were:

Mr. Kolodyazhnyi, Deputy Chairman of the Council for Science

Mr. Pashinin, Deputy Chief, Track Department, Ministry of
Railroads

Mr. Chernysh, Deputy Chairman, International Communications,
Ministry of Railroads

Mr. Alexandrov, Deputy Chief Engineer, Track Department, Ministry
of Railroads

Professor Albrekht, All-Union Railway Research Institute

Also included were Mr. Lukov, the interpreter, Mr. Belov and Mr. Stateynov, all of the International Communications Department of the Ministry of Railroads. A photograph of those who attended is shown in Figure 1. Mr. Chernysh served as Chairman of the Soviet delegation.

The meeting began with a discussion and explanation of the itinerary. The U.S. delegation requested that inspection requirements, planning and logistics be discussed, as well as the electromagnetic acoustic (EMAC) technique for rail inspection. We were given assurances that these subjects would be discussed. However, we were told that we would be unable to talk to the individuals (at the All-Union Scientific-Research Institute of Nondestructive Testing, Kishinyev) who are developing this EMAC technique, because they do not fall under the authority of the Ministry of Railroads.

An overview of the organizational structure and track maintenance and inspection procedures was presented by Mr. Alexandrov. The pertinent areas of this discussion included:

1. The organizational structure of the Track Department from the Ministry level down to the individual work gangs
2. The type of equipment used
3. The inspection requirements
4. Scheduling requirements and planning techniques

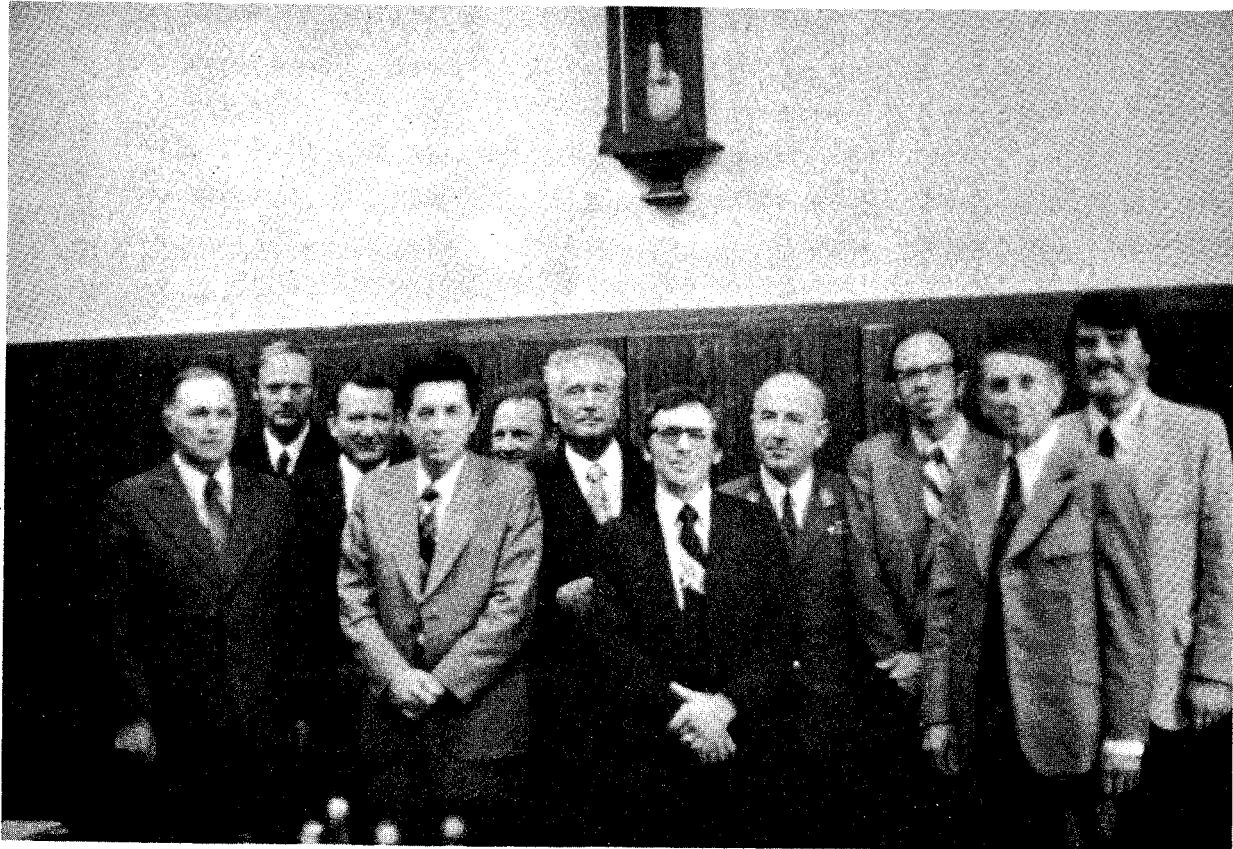


FIGURE 1. U.S. - U.S.S.R. delegations at the Ministry of Railroads. Personnel from left to right are: Professor Albrekht, Mr. Stateynov, Mr. Owen, Mr. Kolodyazhnyi, Mr. Belov, Mr. Chernysh, Mr. Ceccon, Mr. Pashinin, Mr. Bray, Mr. Alexandrov, and Mr. Becker.

The organizational structure of the Track Department consists of five distinct levels: The Ministry, Railroad, District, Line Intersection, and Individual Section work gangs. The Railroad Ministry oversees the operation of each of the 26 railroads which make up the network. Each of the railroads is further divided into three to fifteen districts. Each district contains three to five line intersections of 200 to 300 km. The line intersection is further divided into sections or work gangs responsible for 8 to 10 km of track. The work gangs usually contain three to four men and a foreman who report to a road master, who is responsible for two to three sections.

The operations of the Track Service Department are divided into two major areas: a) running maintenance and b) renewal. Running maintenance includes those operations necessary to assure the safe operation of the railroad, among them nondestructive inspection and rail geometry measurements. Renewal includes capital improvements, medium repair and lifting repair. Medium repair includes track renewal, tie replacement, and cleaning and up-grading of ballast and wayside structures. Lifting repair includes selective rail and tie replacement and ballast additions.

The primary responsibility for nondestructive testing and rail-geometry measurement rests with the line-intersection personnel. The individual railroads and the Ministry systematically supervise the performance of the line intersections. Line-intersection personnel use hand pushcarts and gages for their rail inspections. The railroad and Ministry use the high speed (up to 100 km/hr) ultrasonic, magnetic and rail-geometry cars for inspection.

Scheduling of rail geometry measurements is specified in References (2) and (10). The first level of inspection includes a daily visual inspection, weekly gage measurements and bi-weekly inspection with a pushcart device by the road master and the section foreman. From these inspections the work plan for the next 15 days is established. The second level of inspection includes a monthly visual inspection by the line intersection chief engineer and an evaluation of the track by the high-speed geometry car assigned to the railroad. During this inspection each kilometer is graded on a point system with each out-of-tolerance condition costing a prescribed number of points for every mm out of tolerance. Bonuses are given to the track personnel with the best

track, i.e., fewest points. The third, or Ministry, level of inspection is carried out with a Ministry geometry car approximately every three months. The function of the Ministry is primarily to assist the railroads in calibration and maintenance of their cars.

Scheduling of nondestructive inspection (NDI) of the rail is based on the condition of the track and is determined by the Track Service Department of the line intersection, Railroad or Ministry. The monthly inspection schedule of the line intersection is determined by the equipment and manpower available. A sample schedule for a line intersection in the Kishinyev district of the Odessa-Kishinyev Railroad is shown in Figure 2. With the 4 pushcart devices available (three ultrasonic and one magnetic) the rail is inspected almost once a week by one of the four. Each cart requires two operators and can average approximately 6 km of track per day. The schedule also allots one day a month for training and one for preventive maintenance of equipment.

The frequency of supervision by the Railroad or Ministry depends on the condition of the rail and could be as often as once a week or more than once a month, but usually not less than once a month. High-speed (up to 100 km/hr) ultrasonic and magnetic inspection cars are used for these inspections. There are only four ultrasonic cars; one is assigned to the October Railroad, one to the Odessa Kishinyev Railroad, one to the Shcherbinka test loop, and the fourth is most likely used by the Ministry to check other railroads. The exact number of magnetic cars was not determined; however, the October Railroad had three units and the Odessa-Kishinyev Railroad had two. We estimate, then, that from 40 to 60 magnetic cars are in operation.

Shcherbinka Test Loop

The U.S. delegation, accompanied by Professor Albrekht, Mr. Lukov and Mr. Belov, travelled by car to Shcherbinka station to discuss the operation of the test loop, the high speed ultrasonic inspection car, and an ultrasonic flaw-profiling device used in flaw growth studies.

The Shcherbinka test facility was established in 1932 for testing locomotives. Today the facility consists of three test loops of 5.7, 5.7 and 6 km with approximately 18 km of auxiliary track and 35 laboratories or

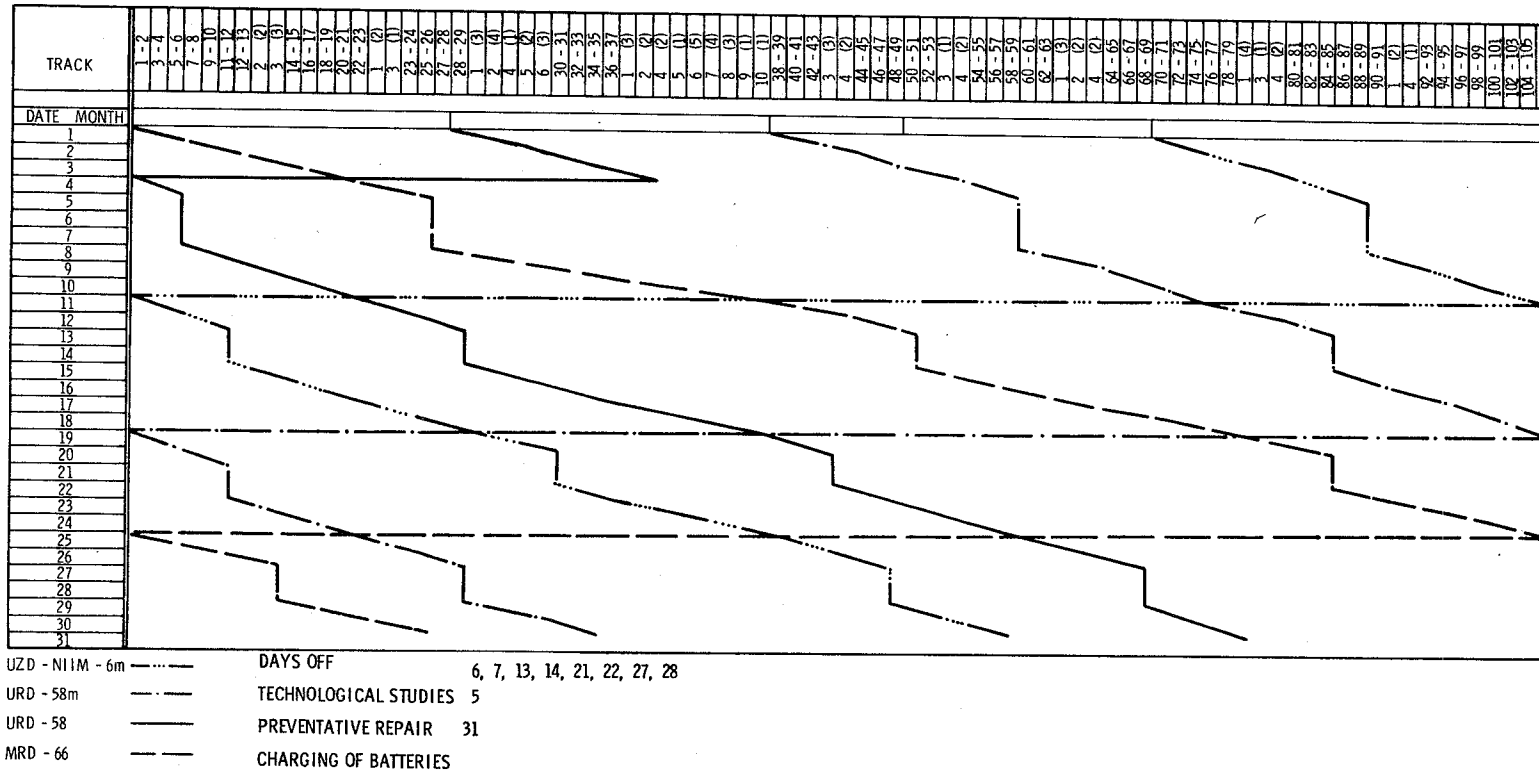


FIGURE 2. Sample schedule of rail NDI for a typical line intersection of the Odessa-Kishinyev Railroad.

shops. The facility is staffed by a permanent labor force with engineers from the All-Union Railway Research Institute (TSNII) directing the experimental work. The outer (6-km) test loop is used to evaluate rolling stock. The inner two loops are used to evaluate rails, ties, fasteners, etc. The inner rings contain curves of 1200, 800 and 650 meters. Accelerated life testing of the rails is accomplished by means of a 8,500-ton train made up of 4-, 6-, and 8-axle cars. Maximum axle loads are 11 to 12 tons. The inner two tracks accumulate 1.2 million gross tons each night or approximately 400 million gross tons per year.

All new designs of rolling stock, rails, ties, fasteners, construction methods and rail NDI equipment must first be tested at Shcherbinka before they can be put into service. In the testing of rails, 30 or more are taken from a particular lot and laid in the test track. The rail is tested daily by conventional ultrasonic techniques (hand pushcart or ultrasonic test car). The detected flaws are also tested periodically with a flaw profiling device to determine the flaw growth rate. After 20% of the rails have failed, the entire group is removed and the defective rails are broken for verification. From the accumulated data the expected service life of the rail can be calculated.

Professor Albrekht has accumulated a large body of data on flaw growth rates under various conditions, which may be useful and informative although not directly applicable to conditions encountered in the U.S., the principal difference being the lower maximum axle loads allowed in the U.S.S.R. Typical four-axle cars in the Soviet Union are rated at a maximum capacity of 60 tonne (66 U.S. tons) and a maximum gross weight of 90 tonne (99 U.S. tons).⁽¹⁵⁾ They have, however, introduced 6- and 8-axle cars of up to 125 tons.⁽¹⁵⁾ While these loads are less than would be experienced in the U.S. they are considerably greater than those encountered in western Europe. Professor Albrekht was interested to learn more about the U.S. experience with high-axle loads as they are also considering allowing the use of increased axle loads. However, their present opinion is that too many shells would occur and that flaw growth rates would increase significantly.

We received one journal paper⁽⁴⁾ from Professor Albrekht which described a flaw-growth-rate study. This paper is in Russian and has not as yet been translated; however, the pertinent graph is shown in Figure 3. This study was conducted by selecting 1.2 meter sections of rail with transverse defects (detail fractures) less than 5% of the head area. These rail sections were

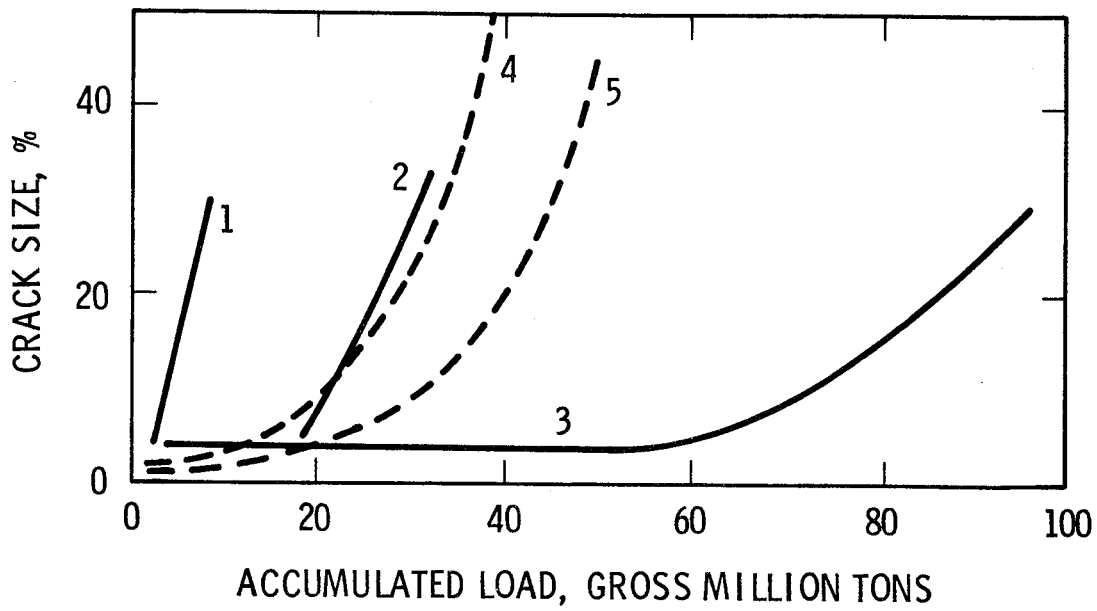


FIGURE 3. Growth rate of detail-fracture-type cracks in R-65 rail as a function of the number of cyclic loadings at loads of (1) 15 tons (2) 12.5 tons and (3) 10 tons. Curves (4) and (5) relate to the growth rate as it would apply for (4) grades and (5) level areas. The crack size listed is the percentage of head area.

then fatigued in bending at loads of 15, 12.5 and 10 tons in the laboratory. The flaw growth rate was measured for each load as the test progressed. The significance of curves 4 and 5 (in Figure 3) is not known; however, it does concern the influence of the grade on flaw growth rate. The abscissa of Figure 3 is the gross accumulated tonnage of the test only, the prior history of the rail is not known. We expect that significantly more flaw-growth-rate data are available.

The basic rail recommended for replacement or new installations is type R-65 installed on concrete ties. Wooden ties are used in areas where the road bed is unstable. Type R-65 rail is 65 km/m and is basically equivalent to 132 lb/yard U.S. Rail. All rail produced since the mid-1960's has been "fully hardened". We did not get a clear explanation of exactly what was meant by "fully hardened"; however, through these and subsequent conversations we deduced that the process is similar to the controlled cooling process used in the U.S. The Soviets' experience has been that fully or through-hardened rail had a flaw occurrence rate 1.5 to 2.5 times less than non-through-hardened rail. They also experience substantially higher flaw occurrence rates on reclaimed rail. However, as we later learned, they do install reclaimed rail in main line tracks.

Mr. Lysenko, who is in charge of Quality NDI at TSNII, described and conducted a tour of the high-speed ultrasonic car assigned at Shcherbinka and demonstrated the ultrasonic flaw-profiling device. A detailed description of these devices is contained in the equipment section of this report. The tour of the inspection car was brief; however, we did get a good description of the car's design and capabilities.

While at Shcherbinka our delegation was interviewed by a television news crew. In the interview, the delegation Chairman, Mr. Ceccon, stated the objectives of the information exchange program, our expectations for increased cooperation, and thanked the Soviet people for the opportunity to visit their country. The interview was shown on national television the following evening.

All-Union Railway Research Institute (TSNII)

After completing our discussions at Shcherbinka the delegation travelled by car back to Moscow to the All-Union Railway Research Institute (TSNII). This visit was scheduled to be a discussion of the Institute's activities with the Director, Mr. Karetnikov. The meeting was, however, purely social, due to our late arrival. A group photograph of the delegation with TSNII personnel is shown in Figure 4.

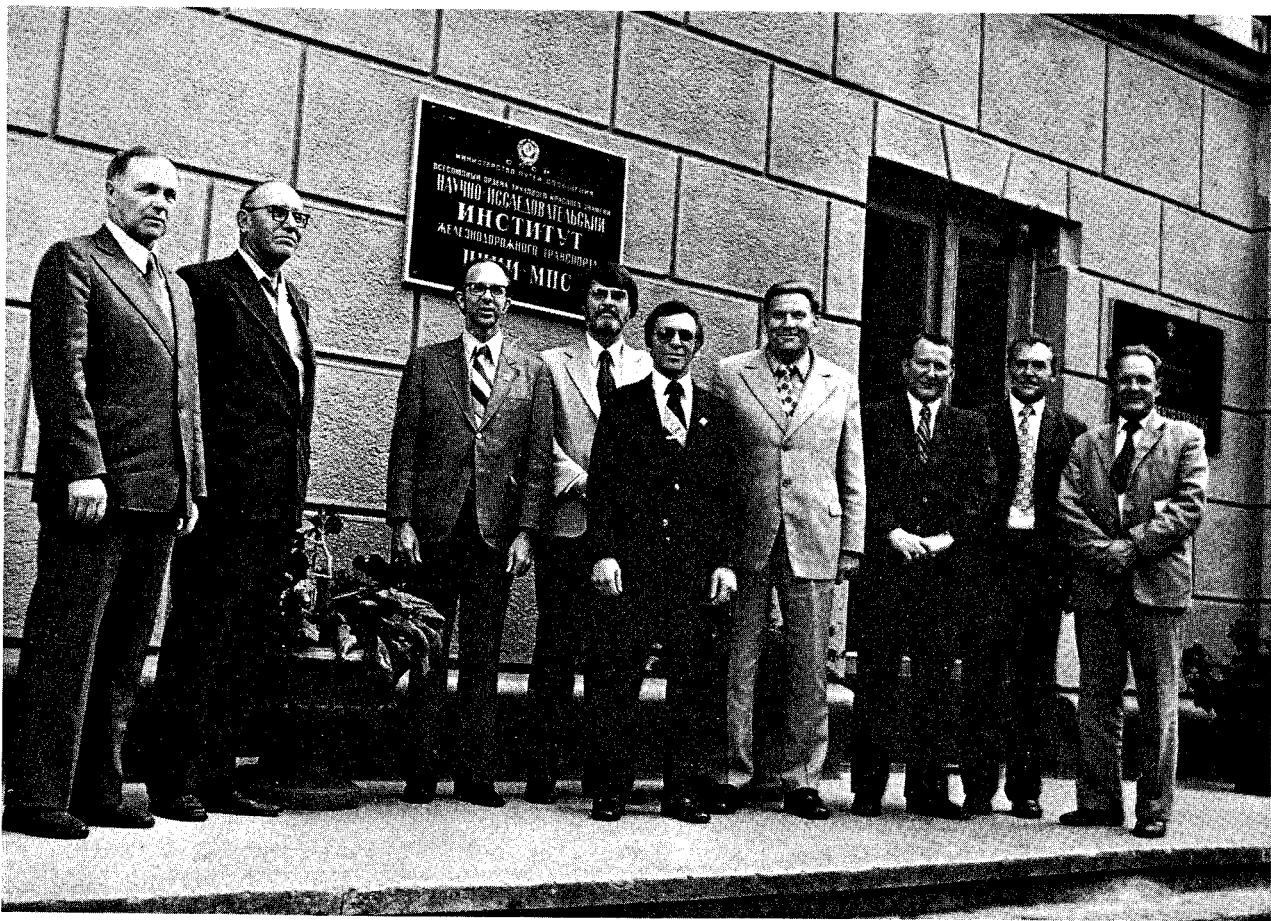


FIGURE 4. U.S. - U.S.S.R. delegations at TSNII; personnel from left to right are: Professor Albrecht, Mr. Lysenko, Mr. Bray, Mr. Becker, Mr. Ceccon, Mr. Karetnikov, Mr. Owen, Mr. Lukov, and Mr. Belov.

TUESDAY, WEDNESDAY, AUGUST 26, 27, 1975, LENINGRAD

The delegation, accompanied by Mr. Lukov and Mr. Belov, travelled by overnight train from Moscow to Leningrad.

Leningrad Railway Engineer Training and Bridge Research Institute

The delegation met with Professor Kraskovsky, Rector of the Bridge Research Institute, on the morning of August 26th. The function and activities of the Institute as a training and research institute were outlined by Professor Kraskovsky and Mr. Selnitski, Chief Engineer for the Bridge Research Institute. Other members of the Soviet delegation were: Prof. Dr. Philpov, Comptroller of the Institute, Dr. Valakov, Deputy Director of the Bridge Research Institute, Mr. Goorvich, Supervisor of Ultrasonic NDI Research at the Bridge Research Institute, Mr. Shabalin, Director of International Communications of the October Railroad, and Mr. Yatzuk, International Communications Dept., October Railroad. A group photograph of those who attended this meeting is shown in Figure 5.

The Leningrad Railway Engineer Training Institute was established in 1802 and is one of 17 such institutes in the Soviet Union. Approximately 1000 professors and scientific officers are working at the Institute. The training and research activities of the Institute include all phases of railroading, including bridge building, welding and nondestructive testing. It is appropriate here to outline one of the main differences between Soviet and U.S. education systems. It is principally in the degree of specialization. Students graduating from high school first decide what branch of engineering (railroading, aerospace, etc.) they wish to pursue. In the case of railroading students, during their first year at the university they then decide what branch of railroading (rail and road bed, rolling stock, motive power, switching and signaling, etc.) they are most interested in. From that point on their education is high specialized in each person's particular area of engineering.

The afternoon of Tuesday, August 26 was spent at the Predportovaya, testing center of the Bridge and Railway Research Institute. Mr. Goorvich, who is in charge of nondestructive testing research, detailed current practice for standardization of ultrasonic testing used throughout the

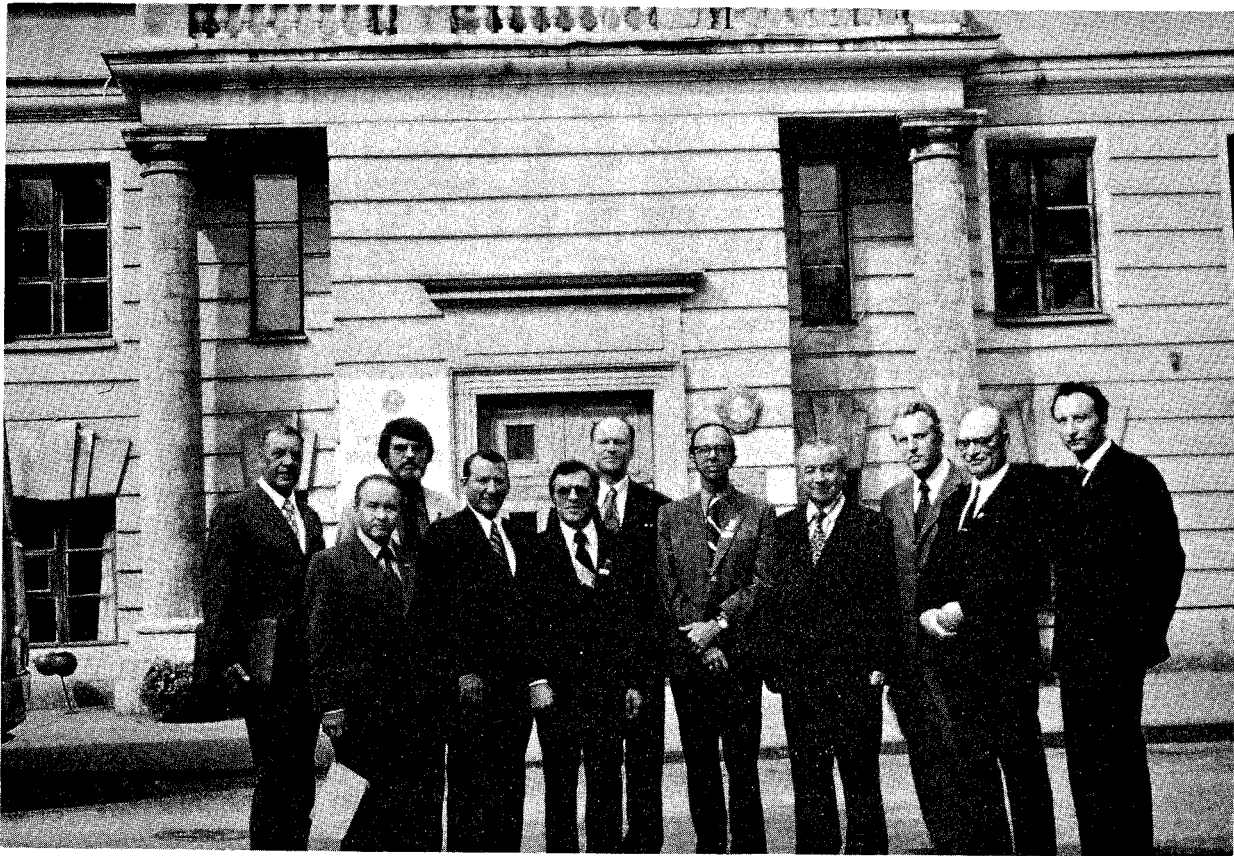


FIGURE 5. U.S. - U.S.S.R. delegations at the Leningrad Railway Engineer Training Institute; personnel from left to right are: Dr. Silnitski, Mr. Goorvich, Mr. Becker, Mr. Owen, Mr. Cecon, Professor Dr. Kraskovski, Mr. Bray, Professor Dr. Philpov, Dr. Volokov, Mr. Shabalin and Mr. Yatzuk.

Soviet Union^(3,9) as well as for rail inspection. NDT engineers Kroog and Kuzmina then described the features of the UZD-NIIM-6M ultrasonic rail flaw detection pushcart and the DUK-13IM ultrasonic weld-inspection instrument.

The basis of the calibration technique is the DGS diagram similar to that described by Krautkramer.⁽¹⁶⁾ The calibration technique is implemented with three calibration blocks:

- o A semicircular steel block for the determination of angle beam exit point
- o A rectangular plastic resolution and sensitivity test block for normal (0° longitudinal) and angle beam transducers
- o A rectangular block made from the material to be tested for the determination of the refracted angle of angle beam transducers.

The application of these calibration techniques is described in References (3) and (9).

A complete description of the UZD-NIIM-6M and the DUK-13IM is contained in the Equipment section of this report. The DUK-13IM is used in rail welding plants for the inspection of welds. It has for the most part been replaced by newer UZD-NIIM-6M for periodic inspection of welds in the field. All welds are manually inspected at least twice a year in the field. Production of the UZD-NIIM-6M cannot now meet the needs of the railroads, and many less efficient units are still used in the field. Mr. Goorvich also complained that they were unable to use the highest-quality electronic components in new NDT instruments as sufficient quantities were not available to meet the needs of higher-priority industries such as aerospace.

October Railroad

The following day, Wednesday, August 27, was spent with officials of the October Railroad and included a demonstration ride on the high-speed magnetic and track-geometry cars.

The first meeting of the day was conducted by Mr. Shabalin, International Communications Director, and Mr. Veniaminovick, Chief of Track Maintenance of

the October Railway. These discussions included rail testing capabilities, schedules and research activities conducted by the railroad, and the development of high speed traffic.

The October Railroad consists of 12,500 km (7500 miles) of main line track and is divided into 45 line intersections. The principal line of the October Railroad runs from Leningrad to Moscow. Three magnetic, one ultrasonic and four geometry measurement cars, plus many ultrasonic and magnetic push carts, were reported to be assigned to the railroad. The geometry cars inspect the Leningrad to Moscow line twice a month. Other geometry inspections include: daily visual, weekly gage measurement, and bi-weekly gage, cross-level and superelevation measurements conducted by the road master and the section foreman. A description of geometry measuring devices is included in the Equipment section of this report.

The October Railroad is currently working on a method of analyzing geometry data with a computer; it is now done manually. It was not clear if the computer would be on the car or in the central laboratory. The research laboratory is also developing a computer code that will use geometry, NDI, and accumulated load data to predict rail replacement schedules.

The October Railroad is also active in developing high-speed train traffic. Trains have reached speeds up to 230 km/hr (138 mph) in experiments. The Soviets plan within the next 5 years to reduce the number of road crossings from 150 to 90 and level crossings from 4 to none. We were given a copy of the latest publication⁽¹²⁾ by the high-speed rail-traffic working group.

The delegation then observed the operation of the geometry and magnetic inspection cars. We rode the geometry car to Lyuban station, a distance of approximately 100 km, where we had lunch. We then returned to Leningrad on the magnetic car. Both cars were operated at speeds up to 100 km/hr (60 mph).

During a discussion on board the cars, we received from Mr. Goorvich a list of detection capabilities and confidence factors for the ultrasonic and magnetic cars as well as for the ultrasonic and magnetic hand pushcarts. The Soviets have greater than 95% confidence

that all detail fractures and transverse fissures (see Figures 6 and 7) larger than 12 mm (≤ 0.5 in.) will be detected by the ultrasonic car and the UZD-NIIM-6M UT pushcart (this is the only UT cart designed to detect transverse defects). They also have a 95% confidence that 12 mm transverse defects that are within 4 mm (.16 in.) from the rail surface will be detected by the magnetic car and the MRD-66 magnetic pushcart. Larger flaws can sometimes be detected by these magnetic devices down to 7 mm (0.28 in.) below the rail surface. Longitudinal defects (horizontal split heads, head and web separation, split web and bolt hole cracks) 15 mm (0.6 in.) long which extend more than 7 mm (0.28 in.) over or through the web can be detected by the 0° or normal beam of all ultrasonic cars and carts, with a 95% or greater confidence factor. They also claimed that vertical split heads 5 mm (0.2 in.) in height and 15 mm (0.6 in.) long could be detected by the 0° or normal ultrasonic transducers with the same 95% confidence factor. The author has serious reservations about this claim. The orientation of the vertical split head type of defect can vary considerably, and only the horizontal projection of the flaw is readily detectable by a normal-beam ultrasonic transducer in the mirror-shadow inspection method. The author could have misunderstood this claim for vertical split heads, as the conversation was conducted under difficult circumstances.

THURSDAY, FRIDAY, AUGUST 28/29, 1975, KISHINYEV

Odessa-Kishinyev Railroad

The delegation accompanied by Mr. Lukov and Mr. Belov travelled by plane from Leningrad to Kishinyev and arrived at approximately 3:00 p.m., Thursday. We were met at the airport by a delegation of officials from the Odessa-Kishinyev Railroad. The Soviet delegation was headed by Mr. Veronin, Vice President, Track Department and included Mr. Stepanov, Vice President and Moldavian District Superintendent, Mr. Evankoff, Chief Engineer Track Service Department, and Mr. Leontev, International Communications Department. The purpose of this visit was to familiarize ourselves with testing procedures and equipment as they are applied by a typical Soviet railroad and to observe the operation of the rail-welding plant.

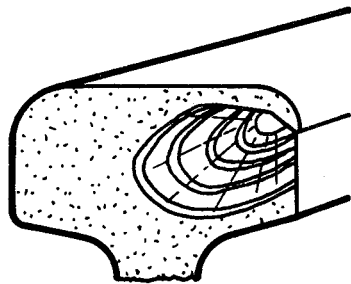


FIGURE 6. Typical Detail Fracture

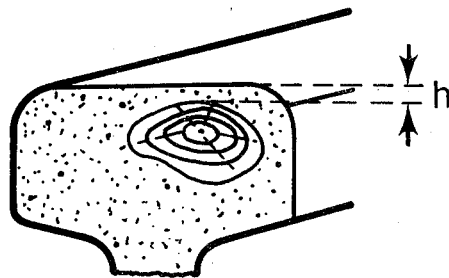


FIGURE 7. Typical Transverse Fissure. Dimension h is the distance from the top of the flaw to the rail surface

The first technical meeting was conducted at the Kishinyev Railroad station and included a demonstration of gage measurement instruments, the geometry pushcart, the MRD-66 magnetic rail-inspection cart, and the URD-58, URD-58M and UZD-NIIM-6M ultrasonic rail inspection carts. The geometry pushcart is a small four-wheel device which measures the gage, cross-level, and superelevation of the rail. The data is recorded on a paper strip chart. This is the device used by the road master and the section foreman for their weekly inspection. A more complete description of these devices is contained in the Equipment section of this report.

The MRD-66 magnetic inspection cart is designed to detect transverse defects in the rail head to a depth of 4 mm. This unit uses a 1500 gauss magnet and four balanced detector coils. The URD-58 and URD-58M ultrasonic inspection carts contain a single normal beam transducer for each rail and the 58M also contains 37° or 45° angle beam transducers. These units are capable of detecting vertical and horizontal split heads, split web, head web separations and bolt hole cracks. The UZD-NIIM-6M ultrasonic inspection cart contains two differential normal beam transducers and a 60° angle beam transducer skewed at 30° toward the gage side of the rail. It was claimed that this unit is capable of detecting all longitudinal and transverse type defects. A more detailed description of these units is given in the Equipment section of this report.

Three high-speed inspection cars, two magnetic and one ultrasonic, are assigned to the Odessa-Kishinyev Railroad. Mr. Veronin was asked which types of inspection equipment were most effective in detecting rail flaws. He replied that the high-speed ultrasonic car and the UZD-NIIM-6M were much superior to the magnetic car and other hand carts. This was not surprising as the magnetic car can detect only transverse defects and those only when they are within 4 mm of the rail surface. The UZD-NIIM-6M is the only inspection cart we saw that was designed to detect both longitudinal and transverse rail defects. The effectiveness of the UZD-NIIM-6M as compared to other inspection carts is discussed in References (17) and (18).

The schedule for rail inspection shown in Figure 2 was obtained at Kishinyev. This is a sample schedule, the actual schedule varies from month to month and will depend on the time of year and the condition of the track. Each inspector is trained and certified for the particular type of instrument he or she is using. Inspectors also receive at least one day per month of additional training. Two people are needed to operate each of the

inspection carts; the second is usually an assistant-trainee.

We also discussed the minimum size flaws considered rejectable and the allowed size of surface conditions such as shells and burns. It is our understanding that the following are considered rejectable and are removed from the track:

1. Any detectable transverse defect
2. Horizontal split heads, head and web separation, split web, and bolt hole cracks extending more than 7 mm (0.28 in.) over or through the web and 12 mm (\cong .5 in.) in length
3. Vertical split heads 12 mm (\cong .5 in.) in length
4. Burns, shells and chipped ends greater than 12 mm in length
5. Corrugations deeper than 4 mm (0.16 in.)

A list of flaw types and rejection criteria is presented in References (1) and (2). Because these references have not yet been translated, we do not yet know if the above are requirements or general policy.

Rail-welding Plant

On Friday, August 29, the U.S. and Soviet delegations travelled by special train to Rail Welding Plant No. 13 at Golta Station. Golta Station is approximately 180 miles northeast of Kishinyev and is located in the Southern Ukraine. The rail-welding plant consists of two lines (in separate buildings), one for continuous welded rail and one for reclaiming used rail. Our tour included only the reclaiming line; however, the other line was said to be similar except for the reclaiming procedures. One welder is used on the continuous line and two on the reclaiming line. The welding machines are of the K109 electric flash butt type and have a capability of 8 to 10 welds per hour. The actual production on the reclaiming line appeared to be considerably less because of idle time caused by other operations.

The flow sequence of the reclaim line is as follows:

1. Cleaning
2. Inspection (for head defects)⁽⁵⁾
3. Straightening
4. Reprofilng of head, gage and field sides only
5. Sorting and classification

6. Welding
7. Scarfing and rough profile grinding
8. Cutting to 25 m lengths and drilling
9. Visual inspection and finish profile grinding
10. Ultrasonic weld inspection

The inspection station is 75 meters beyond the welder on the reclaiming line and 100 meters on the continuous line. If a weld defect is found, the string can be backed up, cut and rewelded. The inspectors detect, on the average, one bad weld per 16-hour day. A rail section approximately 3 feet long is cut out and broken for confirmation. The first rail welded each day is also broken for purposes of process control. The temperature of the rail during ultrasonic weld inspection is less than 60°C. The relatively simple, manual ultrasonic testing (angle beam shear wave) is facilitated by the low temperature of the rail by the time it gets to the inspection station and by the care that is taken in the finish profile grinding. The DUK-13IM was used for this inspection. The device and testing procedures are described in the Equipment section of this report.

We were also told that all joints were normalized by induction heating after welding to maintain a uniform hardness along the rail. However, it was not clear exactly how or when this was done as it appeared that the rails were allowed to air cool after welding.

MONDAY, SEPTEMBER 1, MOSCOW

Rail Transport Ministry

After we completed our tour of the rail-welding plant, the special train returned to Kotovsk where our car was attached to the Bulgarian express for the return trip to Moscow. We arrived in Moscow at approximately 8:00 p.m., Saturday, August 30. Mr. Bray and Mr. Owen left the Soviet Union Sunday, August 31, and Mr. Ceccon left Monday morning. Mr. Becker remained in Moscow Monday for a second meeting with Professor Albrekht and left late Monday afternoon.

The purpose of the meeting with Professor Albrekht was to discuss rail stress measurement and electromagnetic acoustic (EMAC) rail-testing technology. The meeting with Professor Albrekht was brief and concerned only rail-stress measurement.

The only rail-stress measurement technique currently in use in the Soviet Union is based on the strain-gage technique. The equipment and technique are described in Reference (6). In this technique the strain gage is bonded to the base of the rail. The instrument then records the changes in stress. It is apparently difficult to mount the gage properly, and the system requires a complicated calibration procedure. Professor Albrekht also described a modification of the sensor to provide easier mounting. This is shown in Figure 8. The device consists of a strain gage mounted on a beam which is clamped to the base of the rail by pointed clamps.

In the laying and maintenance of continuous welded rail only the temperature of the rail is considered for the determination of thermal stresses. This procedure is described in great detail in Reference (8).

Professor Albrekht also stated that ultrasonic or other stress-measuring techniques are not now under study for use by the railroads. However, from the literature⁽¹⁹⁻²²⁾ we know that these stress-measuring techniques are currently under investigation by other groups in the Soviet Union.

We had requested that we be allowed to discuss electromagnetic acoustic (EMAC) technology with someone from the Rail Transport Research Institute in Moscow. However, we were told that nobody was available on that day. This was a disappointing situation as EMAC technology had been one of our principal objectives of the exchange. We had been promised that EMAC would be discussed when we agreed on the agenda during our first meeting on Monday, August 24. Repeated unsuccessful attempts were made to discuss this subject.

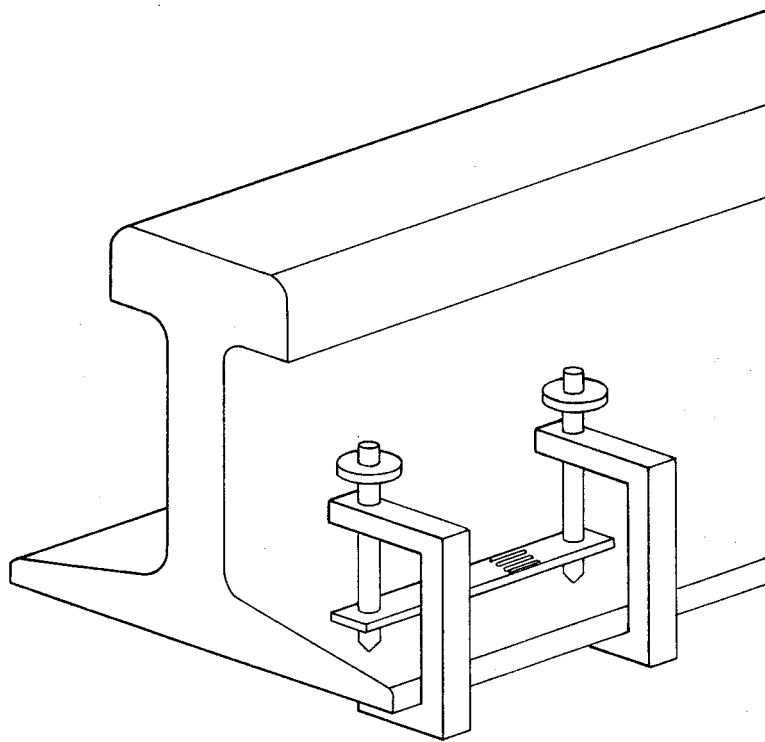


FIGURE 8. Strain-gage device for the measurement of stress in rails

EQUIPMENT AND TECHNIQUES

This section of the report describes the rail inspection equipment and techniques observed during the information exchange. Several of these devices are also described in Reference (14), which is currently being translated. The reference work should provide additional details on these devices. A review of electromagnetic acoustic (EMAC) technology obtained from translated literature is also included in this section of the report.

ULTRASONIC METHODS

Ultrasonic Inspection Car

The ultrasonic rail inspection car is a modified, standard 66-foot car and is pulled by a separate locomotive. The car is rated for test speeds up to 100 Km/hr (60 mph) and was claimed to be capable of detecting all types of transverse head defects, vertical split heads, bolt hole cracks, horizontal split heads and other horizontally oriented longitudinal defects. B-scan test information is recorded on 35 mm film, which is processed and read daily on the car. Coupling water sufficient for testing 100 km (60 miles) is carried on the car. In operation the car averages approximately 300 km (180 miles) per day.

The ultrasonic search units are mounted on a separate four-wheel carriage assembly located approximately 15 ft aft of the forward truck. The center portion of this carriage is shown in Figure 9 and shows the guide shoe and search unit assemblies in their testing position. The guide shoe is mounted on a horizontal shaft and is simply a steel plate forced against the gage side of the head. The search unit assemblies are mounted on a light U-channel attached at each end to a hydraulic or mechanical actuator. The actuators can elevate the search unit assemblies off the track when not in use. The hose at the right end of the mounting bar supplies the coupling water to both transducer assemblies. The transducers are not expected to be raised at forward facing switch points as

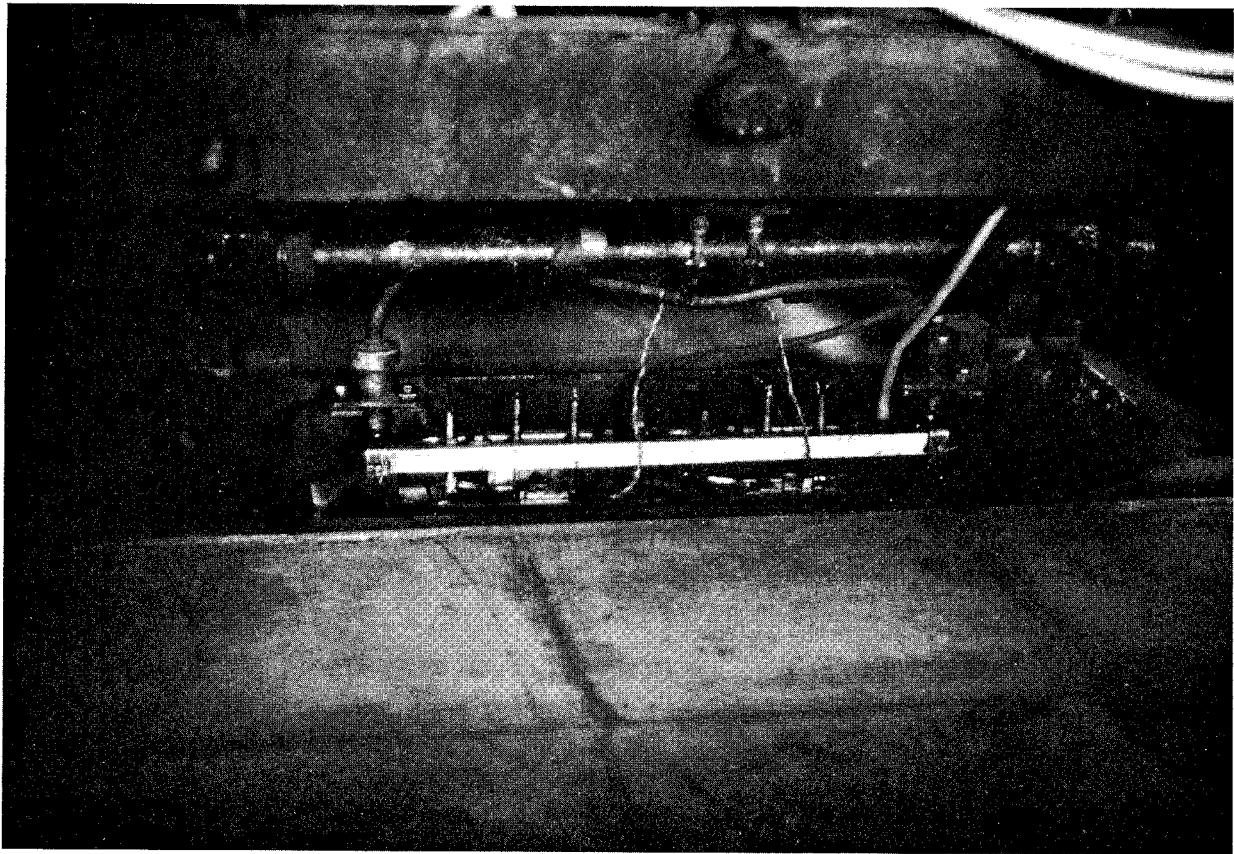


FIGURE 9. Carriage assembly of the ultrasonic inspection car.

the operators cannot see the rail from their operating positions. There also appears to be no provision for lateral adjustment of the transducer position on the rail. The carriage assembly was massive and appeared to weigh 2 to 3 tons. The search unit assemblies, however, were light and were spring-loaded. This combination was probably selected to provide stable dynamic operation of the search unit. Mr. Lysenco also stated that they were considering mounting the carriage under the front truck.

A photograph of the two transducer search unit assemblies in their mounting bracket is shown in Figure 10. Both transducers are 2.25 MHz and are 12 mm (0.5 in.) in diameter. The two transducers are permanently mounted in a 3 x 0.8 in. plastic block. The front face is protected by a snap-on plastic wear shoe which is approximately 0.05 in. thick. The wear shoe is replaced every 200 km (120 miles).

The transducer on the left is the normal or 0° unit. The second unit has a shear refracted angle of 60° from the vertical and is skewed 30° from the longitudinal axis of the rail toward the gage side of the head. It is assumed that both angle beams (one in each assembly) are directed toward the gage side of the head with one directed forward and the other aft. A schematic representation of the skew angle beam technique is shown in Figure 11. This is the same method which is used by the UZD-NIIM-6M ultrasonic test cart.

The "skew angle" technique (a 60° shear wave skewed 30° toward the gage side of the head) used by the Soviets is principally directed at the detection of detail fractures (see Figure 6) located at the gage side of the head. This configuration is claimed to be highly effective for the detection of detail fractures as it is less affected by the orientation of the defect. The efficiency of this detection method results from two factors. First, as the beam strikes the lower surface and radius of the head, it is reflected through a large range of included angles. Second, a defect of the detail-fracture type forms a three-cornered reflector which will reflect the incident sound waves directly back to the transmitting transducer. This technique may, however, be more susceptible (than the 70° method used in the U.S.) to false indications from gage corner shells and burns.

The skew angle technique is considerably less effective for the detection of transverse fissures located in the center of the head (Figure 7). Field side defects would not be detected. We questioned the

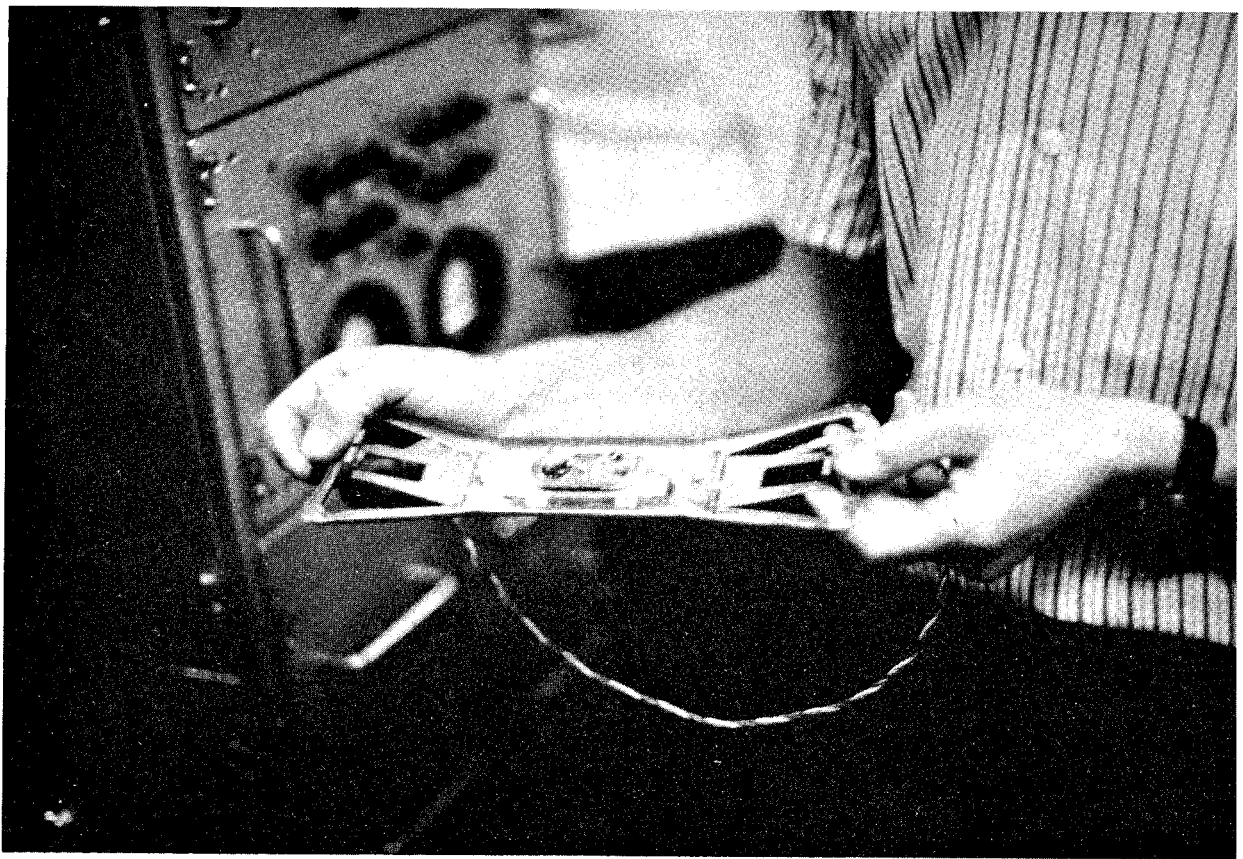


FIGURE 10. Transducer assemblies used on the ultrasonic car.

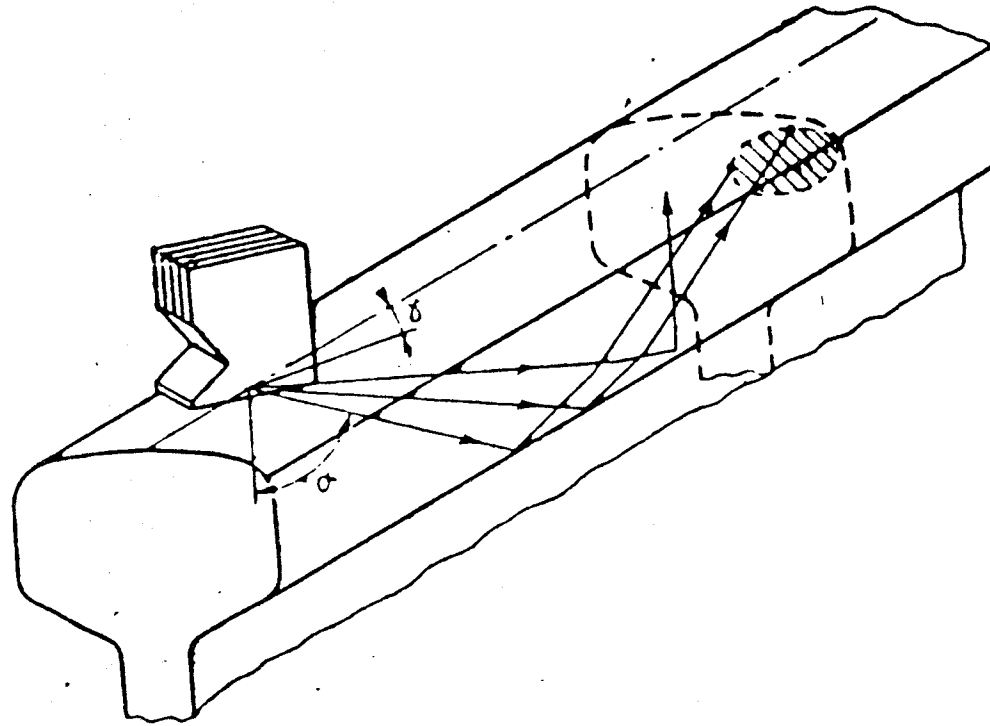


FIGURE 11. Skew angle beam technique. Incident angle $\alpha = 60^\circ$, skew angle $\gamma = 30^\circ$

Soviets several times on the limitations of the "skew angle" technique. Their reply was that transverse fissures did not occur in their through hardened or control cooled rail. However, in other conversations they claimed they could consistently detect 12 mm (\approx 0.5 in.) diameter transverse fissures and detail fractures. The author has serious reservations about this claim for detecting transverse fissures.

The electronic and data recording equipment is located inside the car directly above the carriage assembly. The electronic system (Figure 12) consists of four pulsar receiver channels, two for each rail. The equipment is mounted in two racks with a CRT display for each channel. One channel is used for the normal beam and one for the forward and aft "skew angle" beams on each rail. Analog data are recorded on the four channel strip chart recorder shown in Figure 13. B-scan data are recorded on 35 mm film. The camera is located behind the equipment rack shown in Figure 12. The film is processed and read daily on the car. It was not stated which of the two records was used for interpretation. We believe that the film would be the primary record, with the strip chart being used for calibration runs, for an indication of proper functioning of the equipment, and for eliminating the time lag required to notify repair crews of the existence of large critical defects. The car does not stop to verify defects; they are verified manually before the rail is removed. (18)

In discussing the operation of the car we asked what problems were encountered due to worn rails and corners and their effect on the position and orientation of the search unit on the rail. They replied that they had no problems in this area. In fact, they admitted no problems or operating difficulties with the system. From their daily mileage and effective speed of 37.5 km/hr (22.5 mph), it is expected that the actual normal operating speeds are closer to 70 km/hr (42 mph). This is based on a comparison of the German Railway ultrasonic inspection car (23) which also has an effective speed of approximately 37 km/hr.

During our trip we saw only the one ultrasonic car but did not witness it in operation. The time allotted for discussing this car was extremely brief, less than 1 hour, and we were not able to establish several important characteristics. These include:

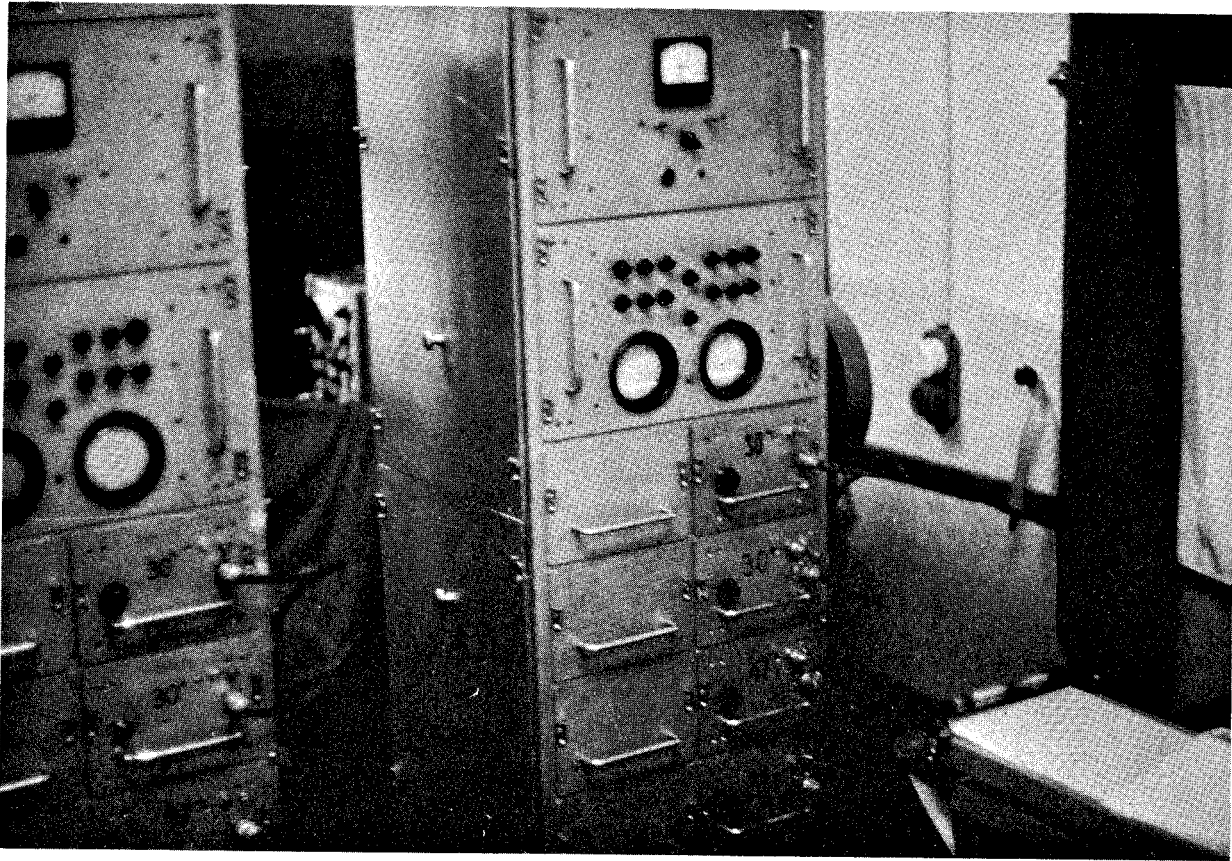


FIGURE 12. Electronic equipment racks of the ultrasonic inspection car.

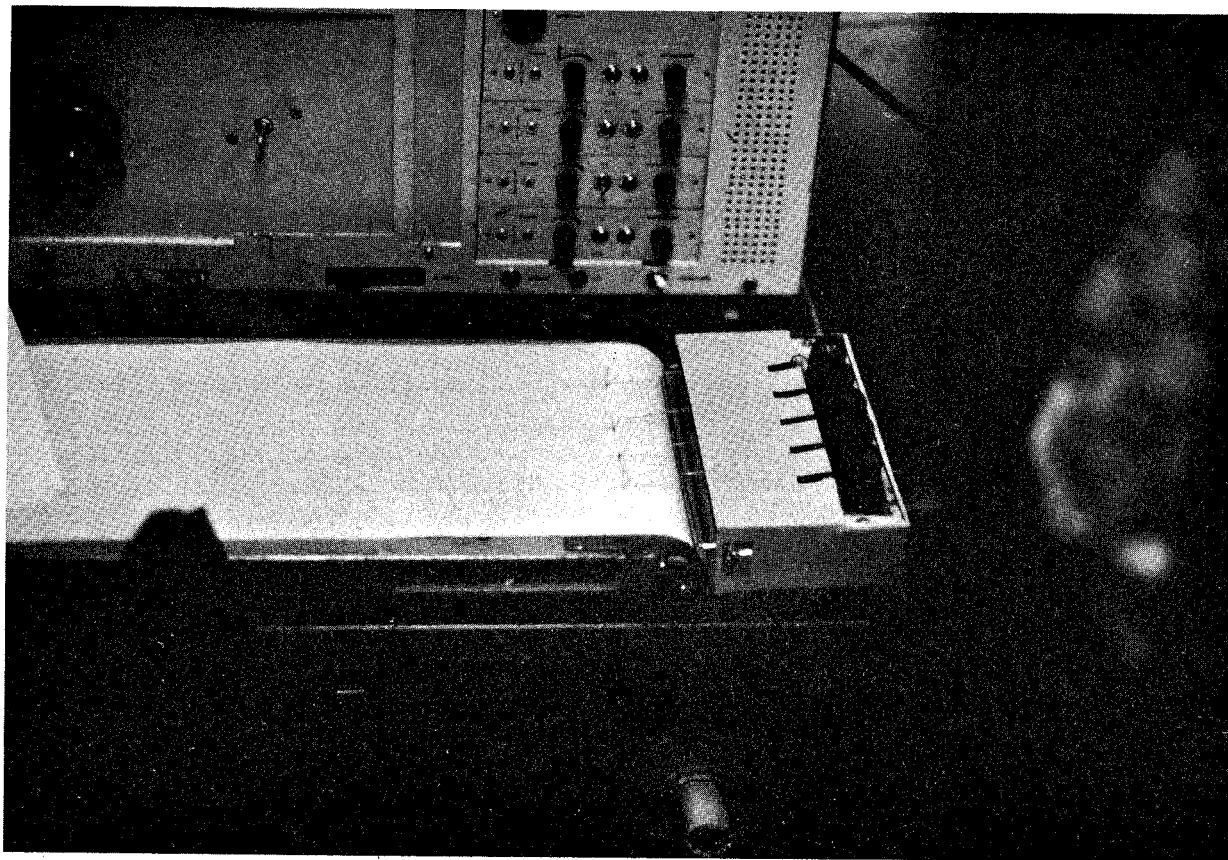


FIGURE 13. Four-pen stripchart recorder for recording test data.

1. The actual crew size.
2. The number of film readers required.
3. The repetition rate of the system.
4. Whether or not AGC or DAC were included in the electronic system.
5. Operating temperature range.
6. If the transducer assemblies are raised at switch points.
7. The rate of false rejection.
8. The number of persons required to verify reported defects.

UZD-NIIM-6M Ultrasonic Rail Inspection Cart

The UZD-NIIM-6M is the newest type of rail-inspection cart in service. A photograph of this unit is shown in Figure 14. The device is described in Reference (14). The unit weighs approximately 100 lbs including the battery and 22 kg (48 lb) of couplant (water with alcohol added for low-temperature operation). The unit operates on a 12v rechargeable battery. An operator and an assistant are required to operate the unit, as well as all other inspection carts. The assistant is required to watch for oncoming traffic as well as to help lift the unit from the track to clear for a train. Approximately 6 km (4 miles) per day can be inspected with this device.

The UZD-NIIM-6M incorporates two unusual detection techniques. The first is called the "ultrasonic caliper"^(3,14) and consists of two normal beams spaced slightly wider than a normal bolt hole (Figure 15). The search units are 0.5 inches in diameter and operate at 2.25 MHz. Simultaneous loss of back reflection from both search units results in a defect alarm. This is an extremely simple technique for discriminating between sound and cracked bolt holes, which could be applied to rapid and automatic rail testing systems, however, it can also respond to other anomalous rail conditions such as extra holes and certain surface conditions. The ultrasonic caliper is used only in the joint bar area. A switch located on the handle is engaged by the operator as the unit is pushed over the joint. A sonic alarm is sounded only when a cracked bolt hole is encountered. Without this dual transducer technique the operator would need to determine the presence of a bolt hole crack by the length of the audio alarm signal. The only automatic bolt hole crack discrimination used in the U.S. is employed by Sperry Rail Service. In the Sperry system, normal beam transducers are used in conjunction with angle beam transducers and the data are processed through a logic system; when predetermined conditions are encountered, either a loss of

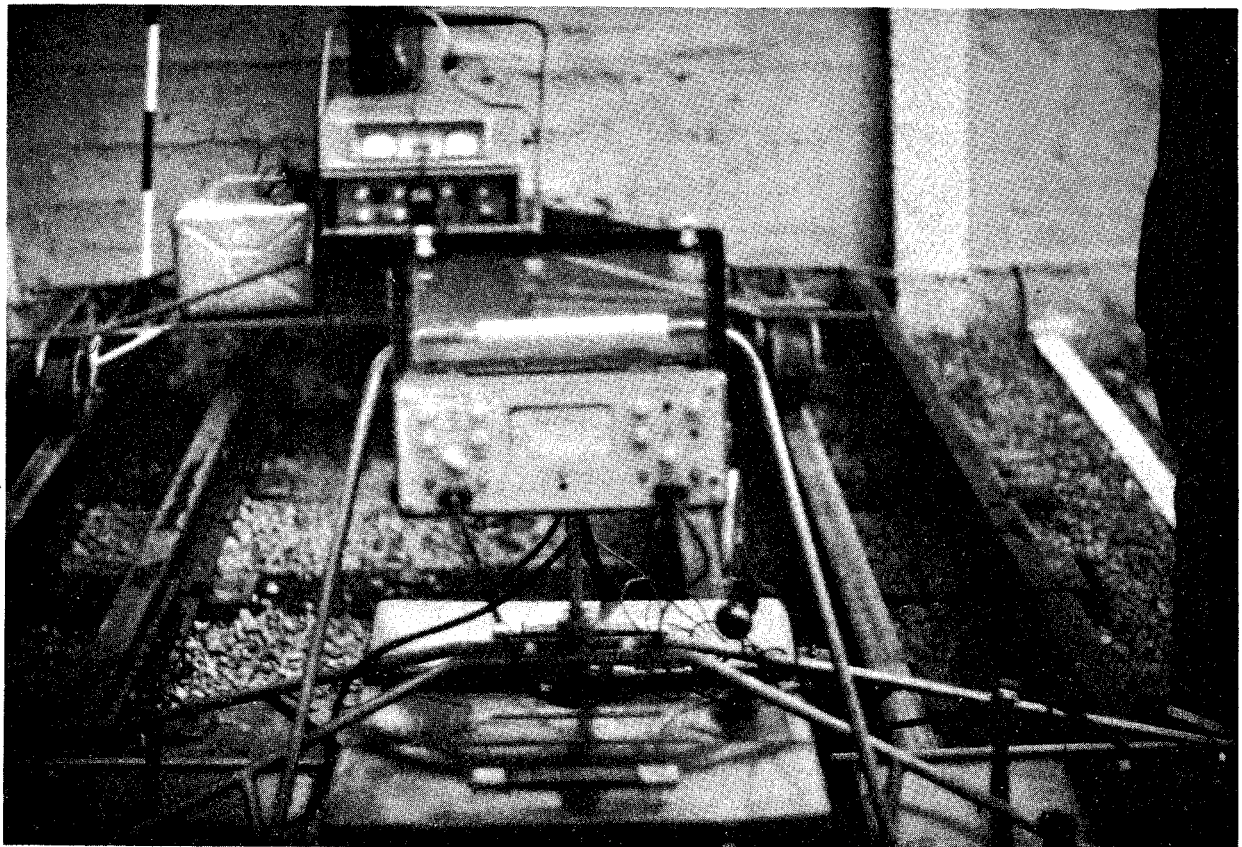


FIGURE 14. The UZD-NIIM-6M ultrasonic inspection cart.

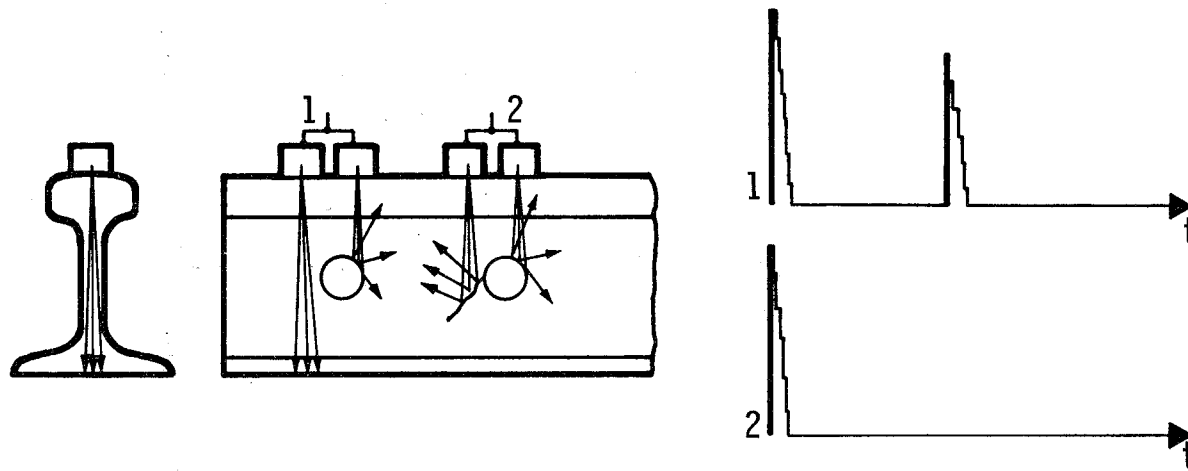


FIGURE 15. Design of the ultrasonic caliper and responses from (1) a sound and (2) a cracked bolt hole

back reflections or a series of back echoes, an alarm is triggered. This requires the use of an automatic repetition rate controller to compensate for the speed of the inspection car.

The second detection method is the "skewed angle beam" technique. This is the same technique previously described for the ultrasonic inspection car; it is shown in Figure 11. Other special features of this device include a meter readout of the defect location relative to the search unit position and auxiliary probes for hand scanning suspected defects. The flaw location device (meter located in the center of the instrument) measures the pulse echo time of flight to the defect. The meter is scaled for each of the shear wave angle beams and the longitudinal wave normal beam to indicate the appropriate distance to the flaw. The auxiliary probes include a normal beam 0° longitudinal and a combination 38° and 50° angle beam shear search unit. The angle beam transducer is also used to inspect welds in continuous welded rail.

This instrument is calibrated in the field by means of the attenuators located in the upper left and right hand corners of the instrument panel. The threshold for each transducer is set relative to the normal back surface reflections. This instrument is capable of operating over a temperature range of -20° to $+50^\circ$ C (-4° to $+122^\circ$ F). Alcohol is added to the couplant for testing at sub-freezing temperatures. We were also told that the 22 kg (approximately 5.5 gallons) of couplant was sufficient for a complete day of testing.

The search units on the rail surface are positioned by a roller guide assembly which is spring loaded against the gage side of the head. The guide assembly and search units are automatically retracted when the unit is lifted from the track to prevent damage during transport.

The Soviets regard this instrument as their most efficient test cart and would like to use it exclusively. However, it will be several years before enough units will be available. The detection efficiency and cost effectiveness of the UZD-NIIM-6M are reported in References 17 and 18. In 1969 on the Odessa-Kishinyev Railroad this unit detected 5.4 times more rail defects per given length of track inspected than the URD-58. The cost effectiveness calculated by the formula given in Reference (18) amounted to a savings of 8,350 rubles per year. This formula takes into account the cost of inspection per defect detected, the number of defects missed, and the cost of train delays. This is not an entirely valid comparison since the URD-58 contains only a normal beam search unit and would be incapable of detecting transverse defects.

URD-58 and -58M Ultrasonic Rail Inspection Cart

The URD-58 and -58M ultrasonic rail inspection carts are vacuum tube devices and are thus considerably heavier than the UZD-NIIM-6M. The units -58 and -58M

weigh 72 and 82 kg (158 and 180 lb) respectively, including 22 kg of water for coupling. The -58 contains only a single 0° longitudinal search unit for each rail. The -58 has an angle beam shear wave probe in addition to the 0° longitudinal transducer. Both search units are 0.5 inches in diameter and operate at 2.25 MHz. The additional electronics for the angle beam transducers apparently account for the heavier weight of the -58M.

The 45° angle beam transducer of the -58M is directed straight down the rail rather than skewed. These units are used to detect horizontal and vertical split heads as well as split web, head and web separations, and bolt hold cracks. The unit does not contain the dual transducer "ultrasonic caliper" contained in the UZD-NIIM-6M, and the operator must determine the presence of a bolt hole crack by the length of the sonic alarm.

Except for the differences listed above, the construction and operation of the URD-58 and -58M are basically similar to the UZD-NIIM-6M. However, the unit cannot detect transverse defects.

DUK-131M Ultrasonic Rail Weld Inspection Device

The DUK-131M is used to inspect rail welds and is used in the welding plants; it has also been used for field inspections.⁽¹⁷⁾ The ultrasonic inspection carts, such as USD-NIIM-6M, are currently used for most field weld inspections. This unit has a CRT (cathode-ray tube), approximately 3 in. in diameter, which was very dim. It also has a sonic alarm and a device for locating the coordinates of the flaw. It did not appear to have any other special features worthy of note.

The search unit contains two transducers, a 40° and a 50° on opposite surfaces. The unit is merely turned over to use the other angle. Both transducers operate at 2.15 MHz.

All welds are ground flush on all surfaces in the rail welding plant. This allows the use of a rather simple inspection procedure without interference from the weld crown. The weld is scanned by hand as shown in Figure 16, using both 40° and 50° inspection beams. This procedure took approximately 5 minutes and did not interfere with the flow of the line. A light oil was used for couplant. The temperature of the rail was less than 60° C, which was slightly warm to the touch.

All defective welds are broken for verification. Figure 17 shows typical types of defects and their locations. Approximately 80% of the defects are found in the lower web and the central portion of the base.

UDM-1M Defectoscope

The UDM-1M is an ultrasonic instrument designed to detect shells and horizontal split heads in rails which have been removed from the track. This instrument is used in the rail reclaiming line of the rail welding plants. The technique is applied during initial cleaning of the rail. A description of this instrument and its operation is contained in Reference 5.

This instrument appears to be an ordinary ultrasonic pulser-receiver unit with a cathode ray tube display. The search unit is a dual element transmit-receive transducer. The two elements are mounted on a plastic shoe and are inclined at approximately 10° towards the center-line of the search unit. The unit operates at 2.5 MHz.

In operation the search unit is placed on the gage side corner of the rail and is directed at the field side fillet radius of the rail as shown in Figure 18. Figure 18 depicts the detection method and CRT signal responses for normal and defective rails. The dual element search unit provides good near surface resolution. The depth of the seam or laminar defect is determined by the number and the spacing of the internal reflections. Loss of back reflection, as well as detection of near-surface multiple reflections, is cause for rejection.

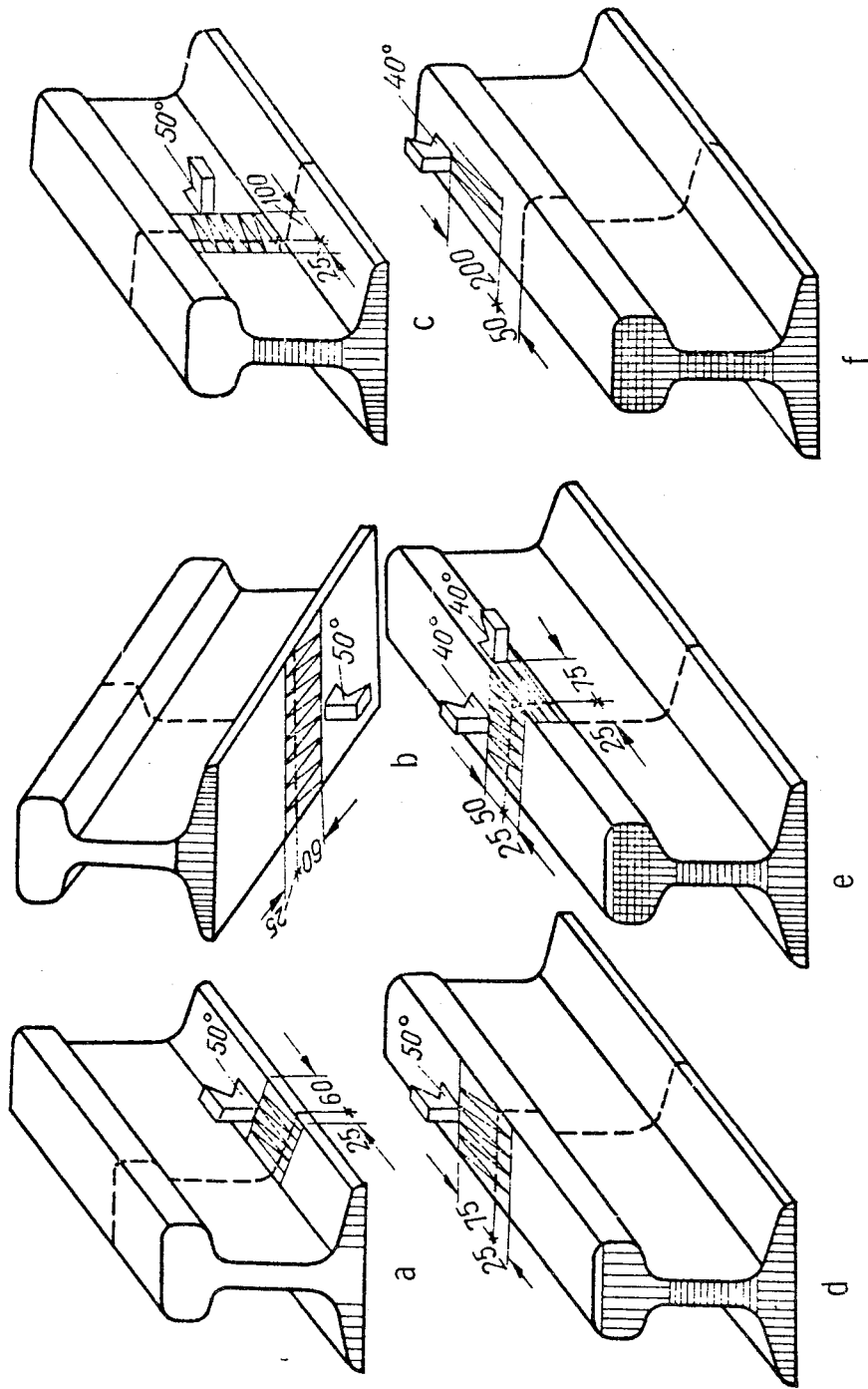


FIGURE 16. Rail weld scanning procedure.

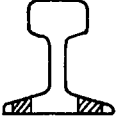


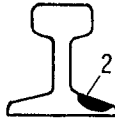
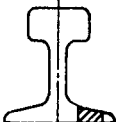
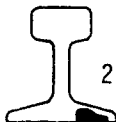
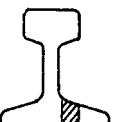
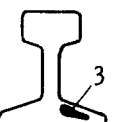
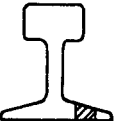
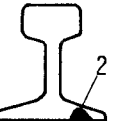
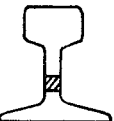
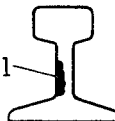

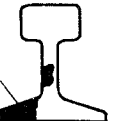
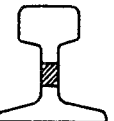
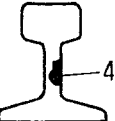
ULTRASONIC INDICATION	DESTRUCTIVE EXAMINATION	ULTRASONIC INDICATION	DESTRUCTIVE EXAMINATION
			
			
			
			

FIGURE 17. Typical rail weld defects: (1) silicate inclusions (2) overburning (3) slag inclusions (4) porosity.

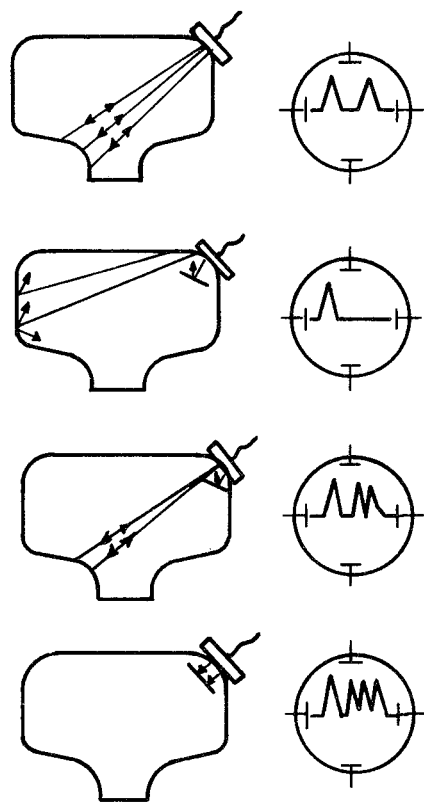


FIGURE 18. Signal responses from the UDM-1M for normal and defective head conditions.

Ultrasonic Flaw Profiling Instrument

The ultrasonic flaw profiling device was developed by the Railway Research Institute for use at the Shcherbinka test loop. The instrument is used to map the area of transverse fatigue cracks in the rail head and to monitor their growth rate. The Soviets claim that the instrument can determine the area of these flaws with an accuracy of 3%. A rather vague description of this device is found in Reference (24).

The instrument is portable and battery operated, and is shown clamped to a rail in Figure 19. A 60° angle beam is scanned longitudinally down and incremented across the rail by the mechanical apparatus. The map of the flaw is recorded on the paper tape by an electric stylus.

The instrument was demonstrated to us at Shcherbinka on a rail known to be defective. The Soviet officials predicted from the recording that the top of the detail fracture was 8 mm (0.32 in.) from the rail surface. The prediction was made with a scaled, elongated plastic template, which is used to correct for the elongated projection of the flaw due to the 60° angle of the beam, at the rail surface. The rail was then broken for verification (Figure 20). The flaw was actually 7.5 mm from the surface. The width of the flaw varied by less than 3% from the width of the recording. The vertical dimension was less accurately recorded because the lower 20% of the flaw was not recorded. By assuming an approximate shape of the defect based on experience, the area of the flaw could be accurately predicted.

The accuracy of this device is much better than that obtained from a conventional C-scan using a transducer 0.5 in. in diameter. The effective diameter of the transducer would have added an additional 0.25 to 0.35 in. to the dimension of the flaw. We assume that the device used one of the compensation techniques described in References (25-28). The technique of Reference (29) (the most likely method) employs a dual element search unit, each element oriented in a slightly different direction. The size and orientation of the elements are chosen such that the half power point of the beams lies on the common centerline of the search unit. Electronic circuitry is provided to compare the amplitude of signals detected by each element. Data are recorded

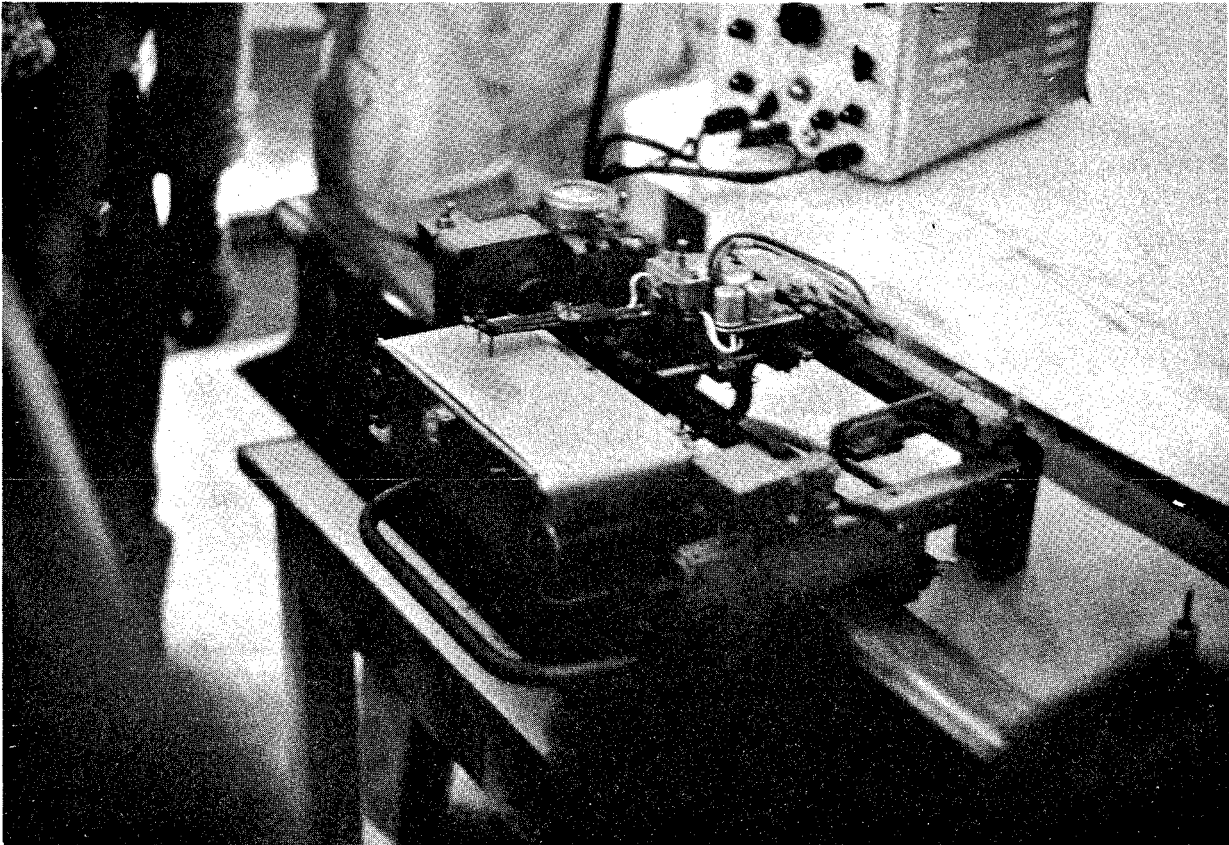


FIGURE 19. Ultrasonic flaw profiler mounted on a defective rail.

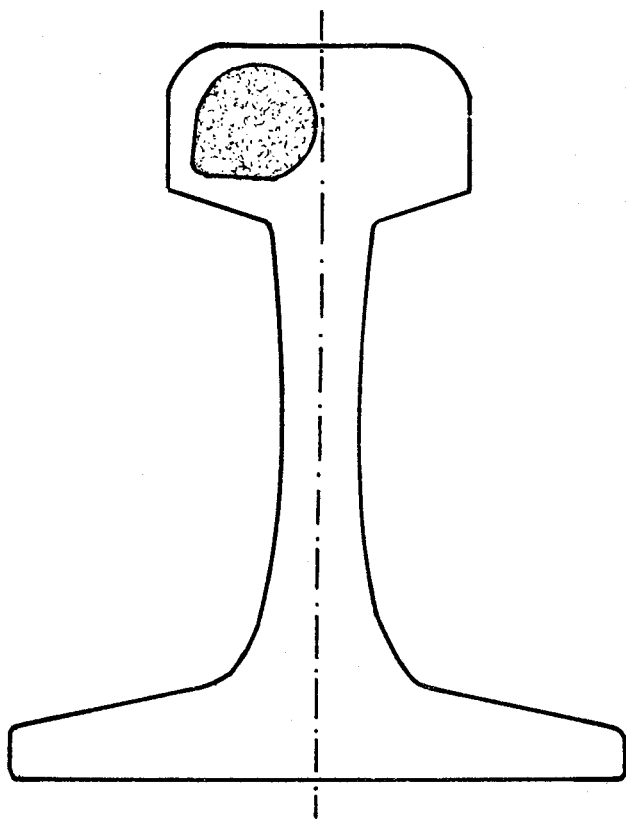


FIGURE 20. Sketch of detail fracture in rail. True nature of defect was revealed by breaking rail

only when the amplitude of both detected signals are equal. In this way the effective width of the transducer is reduced to a thin, pencil-shaped beam capable of accurately recording the actual dimensions of the flaw. A device of this type would be extremely useful for studying flaw growth rates in rail.

MAGNETIC METHODS

High Speed Magnetic Inspection Car

The magnetic inspection car is a standard size 66 ft rail car, pulled by a separate locomotive. The magnetic field is generated by a large electro-magnet suspended from the frame of the car. The single pickup coil is positioned on the rail between the poles of the magnet. The car is capable of testing at speeds up to 100 km/hr (60 mph) and detecting 12 mm (0.5 in.) diameter transverse defects that are within 4 mm (0.16 in.) of the rail surface. Testing information is recorded on a 2-channel tape which is interpreted by the operator as the test progresses. The car that we saw was slightly different from that described in Reference 14 in that the magnet was mounted directly to the frame of the car rather than on a separate truck, and in that test information was recorded on paper tape rather than on film.

The magnetic poles are spaced 850 mm (33 in.) apart with an interpole gap of 650 mm (25.6 in.). The magnetic field produced is approximately 7500 gauss. The detector coil is an elongated air core coil 75 mm x 4 mm (2.95 in. x 0.16 in.); the long dimension of the coil is placed transverse to the longitudinal axis of the rail, with the coil axis parallel to the rail surface. The coil is mounted on a small leaf spring which rides directly on the rail surface.

The Soviet magnetic car uses a different method of flaw detection from those employed in the U.S. The method is based on the phenomenon of a rapidly moving magnetic field producing circulating eddy current fields in the rail. A transverse crack near the surface of the rail perturbs the normal flow of the eddy currents. These eddy current field perturbations are then detected by the detector coil. The effective depth of the eddy current fields is determined by the pole spacing of the magnet and the speed of the car. The effective depth of penetration decreases with increasing speed and shorter pole spacing.

This phenomenon and the influence of various conditions are described in References (29) and (30). The amplitude of the detected signal is so highly dependent on the speed of the car that the method is not effective at speeds of less than 20 km/hr.⁽³¹⁾ Reference (31) describes a modified detector "Ferro Probe" which is designed to minimize this limitation. The details of the "Ferro Probe" are not described; however, we assume it to be a ferrite core coil. The Ferro Probe could extend the effective speed of the car down to 5 km/hr. The Soviets did not mention to us the development of this modified detector. The detector coil on the car that we saw was an air-core type.

One of the major limitations of this system is the difficulty in distinguishing the difference between surface conditions such as shells and burns and transverse defects as shown in Figure 21, which is taken from Reference 14. This figure shows typical responses from surface conditions 1, 2 and 3 and transverse defects 4, 5 and 6. We were given tapes containing indications from 50% and 15% detail fractures, horizontal split heads and wheel burn fractures. The opinion of the delegation is that only the 50% detail fracture was readily distinguishable from surface conditions such as those shown in Figure 21.

The primary limitation of the magnetic car is its depth sensitivity. The magnetic car can detect only those transverse defects within 4 mm (0.16 in.) of the rail surface. We were told that in some instances, for very large flaws, the top of the flaw could be as deep as 5 to 7 mm (0.2 to 0.28 in.) and still be detected. I expect that very few detail fractures or transverse fissures currently detected in the U.S. would be within 0.16 in. of the surface, partly because of the high compressive stress of the work-hardened layer on the rail's surface, which results in the flaw is progressing more in the downward direction.

Suggested methods for automating the magnetic inspection car are described in Reference (32). These methods concentrate on rail-coordinate recording. The methods basically consist of counting the rail joint signals from a given milepost, or counting pulses from an encoder attached to the wheel axle. Methods for automatic interpretation of defect signals are also mentioned, although

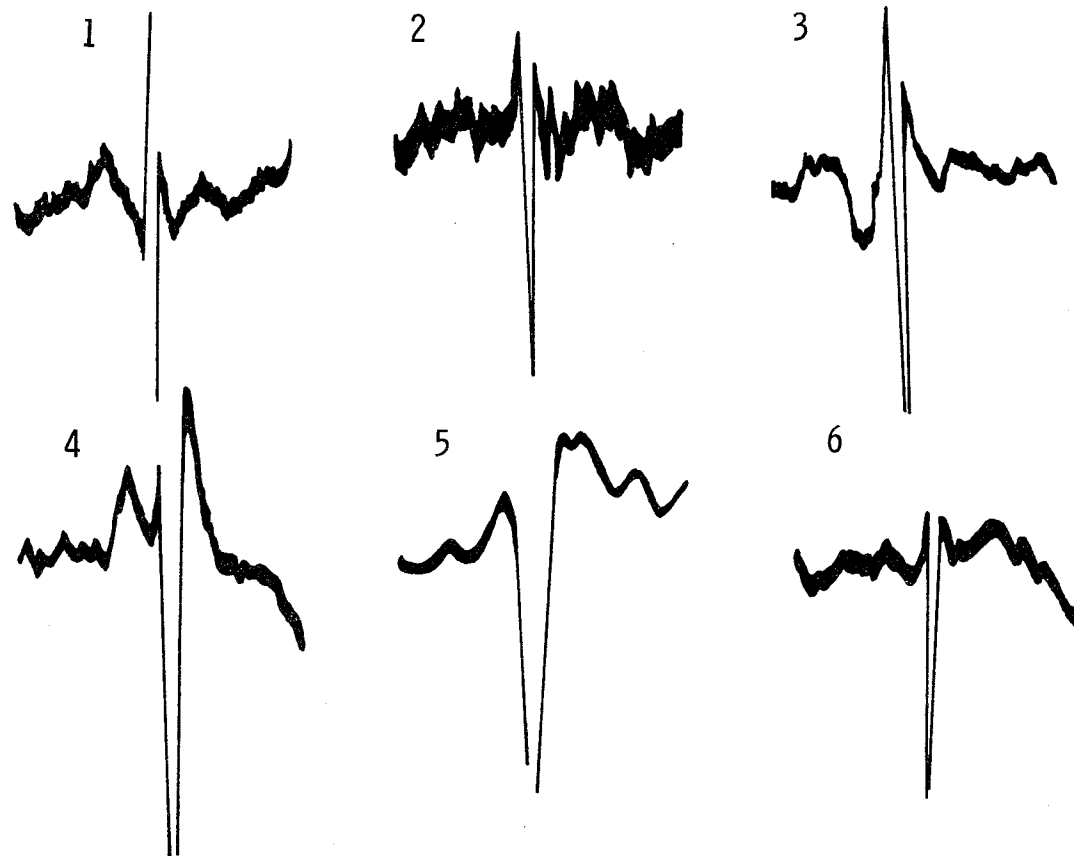


FIGURE 21. Magnetic car defect indications from (1) (2) and (3) surface condition such as burns chips and shells and (4) (5) and (6) transverse defects.

not described in any detail. However, the reference does explain that they involve frequency analysis of the signal indications. The present car does not use any frequency filtering or signal processing. The article⁽³¹⁾ does indicate that by a combination of signal processing techniques the real defects can be separated from surface indications to provide a reliable, automatic defect detection system.

MRD-66 Magnetic Flaw Detection Cart

The MRD-66 magnetic flaw detection cart uses a 1.5K-gauss permanent magnet and four balanced detector coils. The unit is mounted on a four-wheel cart similar to the ultrasonic flaw detector carts. The unit weighs 60 kg (132 lb).

This unit is designed to detect transverse head defects which have progressed to within 4 mm (0.16 in.) of the rail surface. It will also be sensitive to surface discontinuities such as shells and burns.

A simplified schematic of the system is shown in Figure 22. The space between the poles of the magnet is 190 mm (7.5 in.). The poles are held approximately 5 mm (0.2 in.) above the rail. The coils are spaced approximately 12 mm (0.5 in.) apart. The 7.0 KHz oscillator (No. 1, Figure 22) is coupled through the transformer No. 2, to the four coils, No. 3. The coils, with iron or ferrite cores, are connected in the balanced bridge configuration. A nonuniformity of the magnetic field above the rail is a result of a transverse defect near the surface of the rail and will result in a bridge unbalance signal which is detected and amplified by No. 4. The output of No. 4 is rectified and amplified and drives the meter and sonic alarm of section No. 5. The differential nature of the detection circuit makes the unit insensitive to speed.

GEOMETRY INSPECTION

High-Speed Track Geometry Measurement Car

The track geometry car (11) is a standard-size car, approximately 66 feet long, pulled by a locomotive. The car measures and records the following on a paper strip chart: gage, superelevation, alignment (i.e., straightness

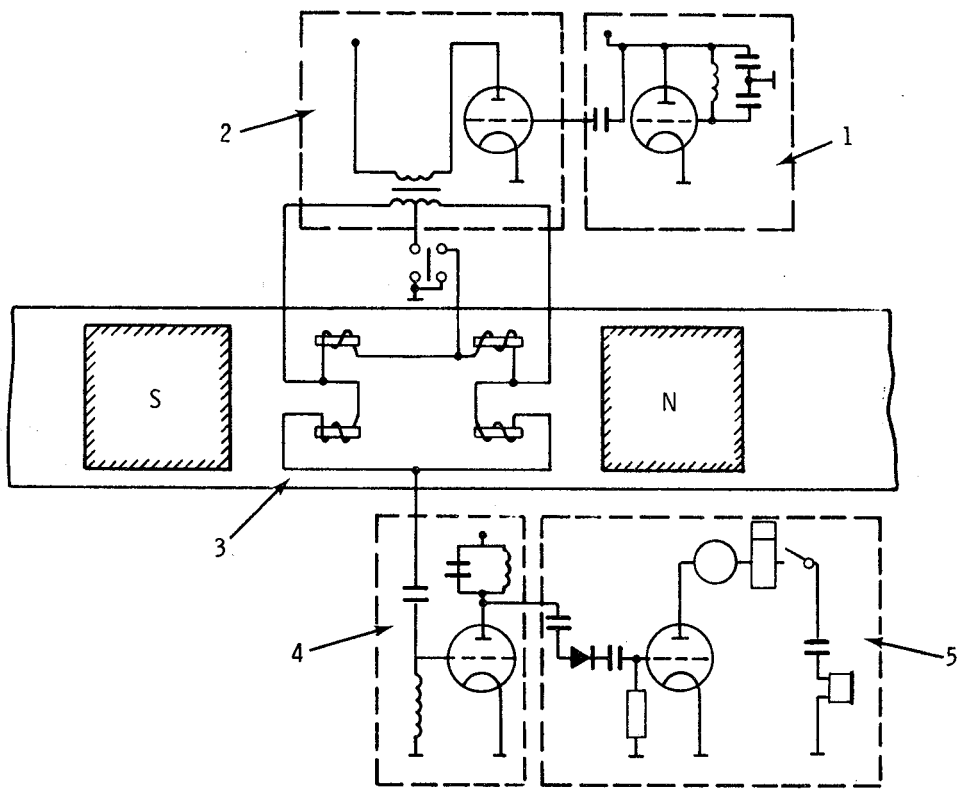


FIGURE 22. Schematic diagram of MRD-66 magnetic rail inspection cart

of each rail), and profile (i.e., surface smoothness of each rail). The system is entirely mechanical and uses cables linked to the measurement wheels and shoes. A gyro is used for the superelevation measurement. The car operates at speeds of 100 to 110 km/hr (60 to 66 mph).

The recording is made on a 200 mm wide chart by ball point pens attached to the cable linkage. Gage is recorded at a 1:1 scale, superelevation 1:2, alignment 1:4, and profile 1:1; the longitudinal scale is 1:2000. Recording limits are: gage 1515-1560 mm (60.6-62.4 in.); superelevation ± 150 mm (5.9 in.); alignment ± 200 mm (7.9 in.); and profile ± 40 mm (1.6 in.).⁽¹¹⁾

This car appeared to be relatively unsophisticated compared to systems currently used in the U.S.

Track-Geometry Measurement Cart

Photographs of the geometry cart are shown in Figures 23A and B. This device is used by the roadmaster (man in black uniform in Figure 23A) and the section foreman for their biweekly inspection. The device is pushed along the track, and gage and superelevation are automatically recorded on the paper tape. The spring-loaded wheels are directly connected to a shaft on which the gage pen is mounted. Superelevation measurements are made by a pendulum enclosed in the triangular box on the left side of the unit. Scales are the same as those used on the geometry inspection car.

ELECTROMAGNETIC ACOUSTIC TECHNOLOGY

Electromagnetic acoustic (EMAC) technology, particularly as it applies to rail inspection, was one of the principal areas of interest to the U.S. delegation. However, we were not able to obtain any information on this subject during the exchange. In lieu of first-hand conversations with the scientist involved in that research, a review of the state of the art obtained from published literature is included in this report.

Our interest in this area is based on the possibility of using EMAC transducers for rail inspection. One of the limitations of current techniques for high-speed ultrasonic rail testing is maintaining uniform ultrasonic coupling

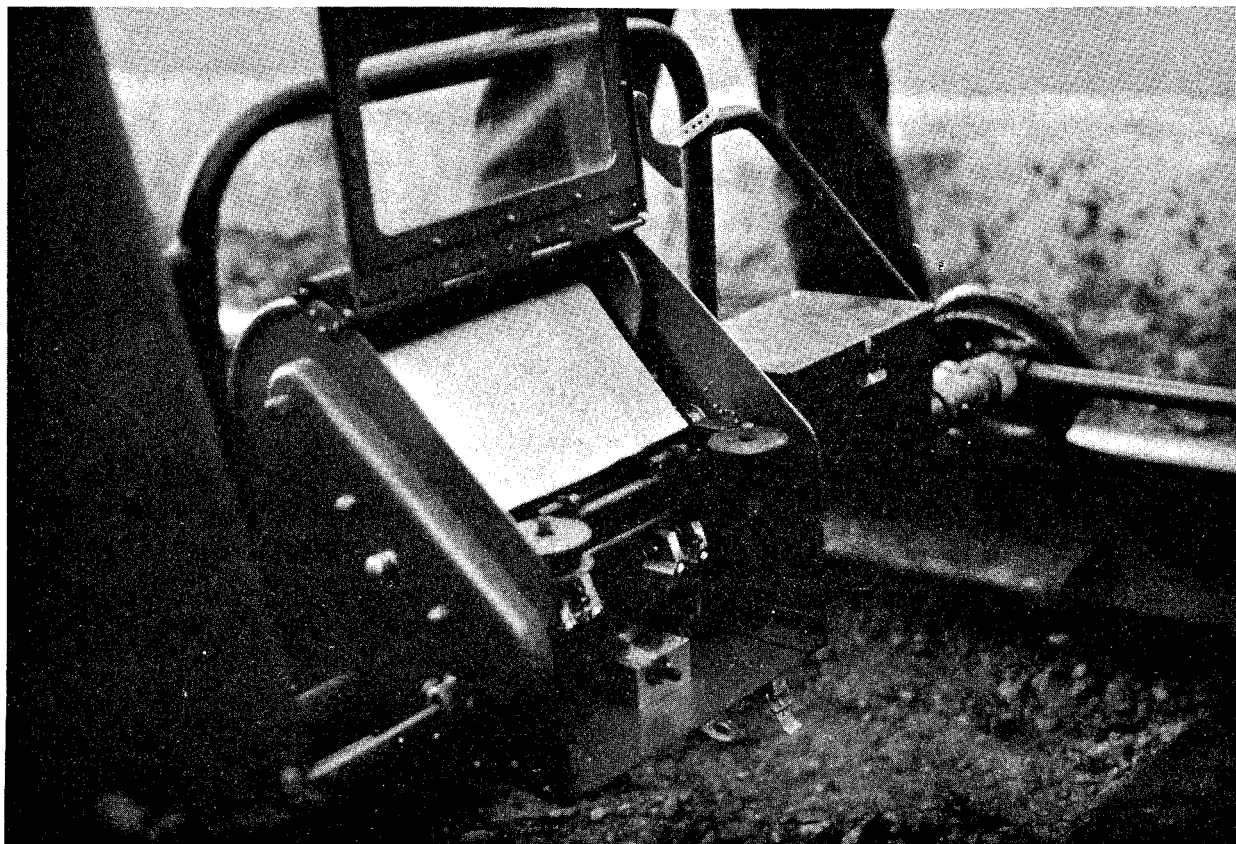


FIGURE 23. Geometry measurement cart.

to the rail surface. This requires large quantities of water and is often insufficient when the rail surface is dirty, heavily rusted, or burned. The principal advantages of the EMAC technique are that it is noncontacting and that it requires no liquid couplant. Its main limitation at present is the low signal strength of the shear waves which are generated (approximately 40 to 60 dB less than conventional piezoelectric transducers). This limitation is partially counter-balanced by the higher sensitivity of the shear waves to defect conditions and by the fact that approximately 95% of the energy generated in conventional wheel-type search units is reflected at the liquid-solid interface.

The electromagnetic acoustic method of generating ultrasonic waves is based on the interaction of high-frequency eddy currents with a magnetic field. The Lorentzen forces connected with this interaction produce mechanical vibrations in the form of an ultrasonic wave. A coil placed near the surface is used to generate the eddy-current field. The direction of the eddy currents and the direction of the magnetic field determine the type of ultrasound generated (longitudinal or shear) as well as the polarization and propagation directions. The frequency of the eddy currents determines the frequency of the ultrasound that is generated. A schematic diagram of the method for cophasal generation of shear waves is shown in Figure 24. Configurations for other forms of the method are shown in Reference (33). In this configuration the magnetic field is vertical; the eddy currents are perpendicular to the plane of the page, and the shear waves generated are polarized in the plane of the page. The signals from each side of the coil are in phase because of the relationship between the direction of the magnetic field and the eddy currents.

Several review papers have been written on this subject. The most thorough presentations are contained in References (33), (34), and (35), all of which seem to agree that in general, the amplitude of the ultrasonic signal depends on the square of the magnetic field and the current in the coil, and inversely on the acoustic impedance of the material.^(33, 34) Papers dealing with the construction of the EMAC transducer and the characteristic of the field generated are included in References (36) through (45). Two relatively recent papers^(46, 47) describe the EMAC generation of ultrasonic shear waves at an oblique incident angle, which should be of considerable interest for nondestructive testing applications. Papers dealing with specific applications of

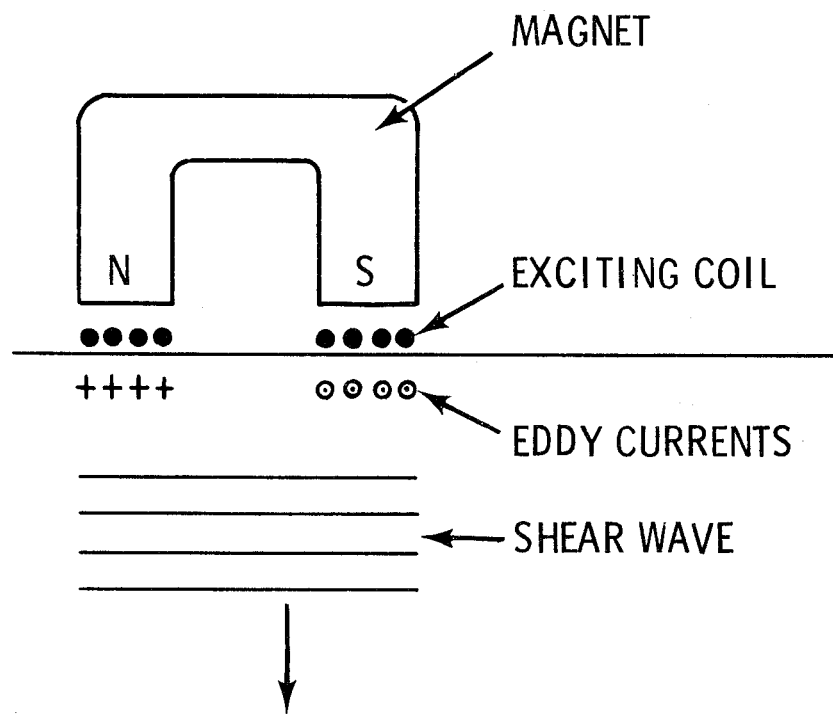


FIGURE 24. Schematic representation of cophasal shear wave generation by an EMAC transducer. Shear waves generated by each half of coil are in phase.

the EMAC technique include the following:

- High temperature testing (48)
- Lamb and Rayleigh wave testing (49, 50, 51)
- Inspection of plates and tubes (52, 53, 54, 55)
- Thickness measurement (56)
- Stress measurement (21)
- Inspection of railway rail (57).

The experimental system for EMAC inspection of rail, described in Reference (57), is a modification of the Soviet magnetic inspection car. An elongated EMAC coil is placed under one of the poles of the existing electromagnet. The coil is attached to a positioning shoe on the surface of the rail. The coil and magnetic field produce shear waves polarized parallel to the surface of the rail. The operating frequency is 1.50 MHz. Reflections from the bottom of the rail are monitored by the mirror shadow method (loss of back). Loss of bottom reflection signals results from both the shadow of the defect and the change in the direction of the polarization vector of the reflected wave, which is caused by the same defect. The change in the polarization vector increases the sensitivity of the EMAC system to vertical split heads and other vertical defects, over that which could be achieved using longitudinal waves. It is also possible that the shear waves of this or a similar EMAC system could detect detail fractures and transverse fissures by using this polarization sensitivity of the shear waves. The elongated EMAC coil is used to compensate for the shift in the position of maximum EMAC generation, which varies with the speed of the car. The coil effectively compensates for speeds up to 70 km/hr (42 mph).

In the test reported in Reference 57, 80% loss of back was achieved for bolt holes and butt joints. The change in bottom surface reflection varied less than 30% at speeds up to 60 km/hr (42 mph). Comparative tests made with the EMAC and a conventional piezoelectric transducer showed that "contamination" on the rail surface resulted in complete loss of back reflections for the conventional transducer but did not influence the EMAC signal. The EMAC method's freedom from surface conditions is also reported in Reference (53).

In summary, the EMAC rail inspection system holds considerable promise for field application. The system has no need for a liquid couplant and is

free from the influences of surface conditions: these are its main advantages. With the addition of the angle beam methods,^(46, 47) the EMAC system might effectively compete with present liquid-coupled ultrasonic methods. However, EMAC is still a developing technology and considerable development will be required before a practical EMAC rail inspection system could be applied in the field.

APPLICABILITY OF SOVIET RAIL-TESTING TECHNOLOGY FOR U.S. APPLICATION

Some areas of Soviet rail testing technology could be applied in the U.S. Further investigation will be needed to establish the degree of applicability. Other areas would be of interest only as a matter of general information. However, before assessing Soviet rail testing technology for application in the U.S., it is important to outline some of the differences between two systems. These differences include testing philosophy, cost of inspection, condition of the rail, and the economic impact of high-speed rail testing.

In the Soviet Union the rail is inspected by manual and pushcart devices on the average of three to four times per month and checked monthly by high-speed magnetic or ultrasonic cars. In the U.S. we rely primarily on relatively slow (7 to 13 mph) rail-inspection cars which stop to verify each defect. The current U.S. system of rail inspection is dictated by costs, capabilities of the cars, and the economic impact of speed restrictions imposed when more defects are found than can be replaced in one day. The Sperry Rail Service reports⁽⁵³⁾ that their fleet-wide average for rail defect occurrence is approximately 0.66 defects per mile of track per inspection. Inspection of 300 km or 180 miles of track per day would far exceed the railroads' current ability to replace rail.

The cost of the rail inspection in the Soviet Union would be prohibitively high for application in the U.S. It is estimated, from the inspection frequency and distances inspected, that 108 to 144 labor-hours/year/track mile are required for the pushcart inspections alone. It is estimated that in the U.S. inspection costs are on the order of \$150/year/track mile based on three inspections per year. We estimate that approximately 10,000 miles of track in the U.S. is inspected as often as three times per year. The remainder is inspected annually or semiannually.

A second factor influencing the use of high-speed inspection systems is the condition of the rails. Soviet and European rails generally have fewer surface anomalies such as severe wear, chipped ends, burns and shells, because of their more intensive maintenance programs and the use of lighter axle loads. The condition allows them to obtain test information at 60 to 80 km/hr (36 to 48 mph) with sled-type search units. The roller search units,

used by many of the U.S. cars to accommodate these rail conditions, are currently limited to speeds of less than 25 mph. However, the major limitation of present U.S. inspection cars is the inability of the operator to interpret the test data. This is also a limitation of British, German and Soviet systems as a film reader can evaluate approximately 15 km⁽²³⁾ (9 miles) of track in a day. It would require 20 film readers to read the daily output of a car averaging 300 km a day at this rate.

MAGNETIC INSPECTION CAR

For the following reasons the Soviet magnetic car or one similar to it would not be effective for U.S. applications.

1. It is sensitive only to transverse defects that are within 4 mm (0.16 in.) of the rail surface. It is expected that fewer than 20% of the detail fractures and transverse fissures which are currently detected would be within 4 mm of the surface.
2. The large number of shells and burns in U.S. rail would make interpretation of test results very difficult and would require a lowering of the testing speed.
3. The Soviets also stated that they were not satisfied with the magnetic car and would like to replace it with ultrasonic cars.

ULTRASONIC INSPECTION CAR

The most significant features of the ultrasonic car are the transducer mounting assemblies, the replaceable wear shoe, and the skewed angle beam transducers. The instrumentation appears rather crude by our standards.

The transducer mounting assemblies, shown in Figures 9 and 10, appear to be well designed for high-speed operation. With the addition of automatic alignment to compensate for rail wear on curves, this type of sled unit could probably be used for high-speed rail testing in the U.S. Mr. Owen of Sperry Rail Service does not concur with this conclusion:

"Sperry Rail Service has proved conclusively to ourselves in 1959 that skid type search units, with or without wear shoes, were not usable on U.S. rail conditions."

The skewed angle beam (60° shear wave skewed 30° toward the gage side of the head) may also be applicable to U.S. rail testing as it is directed at detecting detail fractures. However, the skewed angle beam could not replace present 70° angle beam probes because the 70° beam is more effective in detecting transverse fissures that occur nearer to the center of the head. The prevalent use of turned rail would also require a second set of probes directed toward the field side of the head.

The replaceable plastic wear shoe is not particularly novel; however, it appears to be one good solution to the problem of transducer wear of sled-type search units.

OTHER ULTRASONIC TECHNIQUES

The ultrasonic flaw profiler and the ultrasonic caliper used in the UZD-NIIM-6M inspection cart appear to be new ideas that may have significance to U.S. rail testing. Ultrasonic inspection at the rail welding plant is also of some interest to the U.S.

The ultrasonic flaw profiler would be of great assistance in determining flaw growth rates in U.S. rail under various loading conditions. A device of this type is not currently available in the U.S.

The "Ultrasonic Caliper" used in the UZD-NIIM-6M inspection cart is a method for detecting bolt hole cracks. The device contains two normal beam transducers which span the bolt hole. A defect signal is obtained only when both transducers are shadowed by a bolt hole and a crack. No signal is obtained from normal bolt holes.

The "Caliper" technique may have some application for high speed inspection cars. The principal advantage of this technique is that it would require analysis of only abnormal conditions which would substantially reduce the work load of a computer based inspection system. Its principal limitation, as with other automatic bolt hole crack detection techniques, is that it can also respond to non-rejectable conditions such as extra bolt holes, chipped ends, weld-repaired ends, and surface conditions which result in loss of transmission. For this technique to be effective for a high-speed inspection system, additional information from other transducers would be required in order to minimize the false rejection rate. A second limitation is that the technique would be difficult to implement in a wheel search unit due to space and foot print area limitations. Further analysis will be required to determine the applicability of this technique for U.S. rail testing.

It is also important to note that the Soviets perform ultrasonic inspection in the rail welding plants. Many experts agree that present magnetic particle inspection applied in U.S. rail plants is less than adequate. The general reluctance to apply ultrasonic weld testing in the U.S. is based on the industry's output rates, higher temperatures at the time of inspection, a general inability to back the line up more than one rail joint for rewelding of defective joints, and the relatively rough profile of the weld. A manual inspection method such as that used by the Soviets is not appropriate for U.S. testing. However, it is within the limits of current technology to provide automatic testing systems for inspection using high-temperature search units. However, before such a testing system could be applied in U.S. rail welding plants, the economic effectiveness would have to be determined.

GEOMETRY MEASUREMENTS

The equipment and techniques for geometry measurement used in the Soviet Union are relatively unsophisticated by U.S. standards. In this field the Soviets would benefit from the information-exchange program.

EFFECTIVENESS OF EXCHANGE

The results of our trip as a part of this information exchange program did not meet all of our expectations in several areas. This should probably be expected, for at this stage of the exchange program both parties are reluctant to give out more information than they receive. The exchange did have positive results, which we feel achieved many of the program's objectives.

The trip's biggest disappointment was our failure to receive information on electromagnetic acoustic (EMAC) rail testing. We understand that this area was included for future consideration, and a letter has been prepared requesting a review of the Soviets' current state of development of this technique.

The objective of the Soviets was to provide us with an overview of their current practice, intending that future exchanges would cover more detailed information. It had been our hope to concentrate more heavily on current areas of research and the direction of future developments to improve rail testing. Although the Soviets answered specific questions, in general we were allotted very little time in which to ask any questions.

We did obtain a good description of the organizational structure and responsibility of the track service department. We also received a thorough overview of current practice in rail testing. We also believe that our experiences will help future delegations to be more effective. Even though we did not achieve all of our expectations, the delegation believes that the exchange was a successful one. The success of this exchange should help to advance the overall purposes of this information exchange program as well as the present national policy of developing improved relations with the Soviet Union.

RECOMMENDATIONS FOR FUTURE EXCHANGES

We recommend that research areas of rail testing, particularly in the area of electromagnetic acoustic rail testing, be considered for future exchanges. Based on our experience we make the following recommendations to improve the effectiveness of future exchanges:

1. Better communication before the delegation departs is the most important area for improvement. The agenda should be agreed upon well in advance. If this is not possible, the delegation should insist that important areas be covered and should be informed as to where and when the subject will be discussed. Although it is difficult for the Soviets to change their plans, it would be preferable to wasting time on trivia.
2. The inability to talk to persons not under the jurisdiction of the Ministry of Railroads will limit the effectiveness of future delegations. This point should be stressed in future negotiations as it assuredly limited the effectiveness of this exchange.
3. The number of geographical areas should be limited to no more than two for a 1-week trip. A sufficient number of days should be requested to allow for expected travel and possible revisions in the agenda.
4. It would be extremely helpful on many occasions to have an American interpreter. We frequently found it difficult to ask questions as the Soviet interpreter was engaged in another conversation.

REFERENCES

- ✓ 1. Anonymous, Rail Defect Manual, RTM32/TSP-1-66, -2-66 and -3-66, Transport Publishing House, Moscow, 1967.
2. Anonymous, Instructions for Present Day Maintenance of Railroad Track, Transport Publishing House, Moscow, 1969.
3. Anonymous, Railroad Rails, Methods of Ultrasonic Inspection, Soviet Government Publication 18576-73, Transport Publishing House, Moscow, 1973.
- ✓ 4. C.A. Kolotooshken and V.L. Poroshen, "Research of the Growth of Transverse Fatigue Cracks in Rails," Publication No. ODK 625.143.3.001.5, p. 45-47, date and journal title unavailable.
- ✓ 5. Anonymous, "Ultrasonic Examination of Rails Removed from a Railroad Track," Publication No. 625.143:620.179.16, date and journal title unavailable.
6. Anonymous, "Information about Methods of Measurement and Apparatus for Determining Stress in the Rails," Ministry of Rail Transport, Moscow, 1975.
7. V.G. Albrecht and A.F. Zolotarsky, editors, Contemporary Construction of the Superstructure of Railroad Track, Transport Publishing House, Moscow, 1975.
8. A.I. Zakatalova, editor, Technical Conditions for Laying and Maintenance of Jointless Track, Transport Publishing House, Moscow, 1970.
9. Anonymous, Seams of Welded Joints, Methods of Ultrasonic Defectoscopy, (Soviet) Government Publication No. 14782-69, Moscow, 1970.
10. Anonymous, "Methods and Means of Examining the Condition of Railroad Track Superstructure," Ministry of Railroad Transport, Moscow, 1975.
11. Anonymous, "Construction and Test of the Operation of High Speed Track Measurement Car of the System TSNII," Ministry of Railroad Transport, Moscow, 1975.
12. Problems of Development of Rapid Moving Trains, 24 chapters, Railroad Transport Publishing House, Leningrad, 1974.
- ✓ 13. A.K. Gurvich and M.N. Ermolov, Ultrasonic Inspection of Welded Seams, Technical Publishing House, Kiev, 1972.
14. A.K. Gurvich, et al., Flaw Detection in Rails, Transport Publishing House, Moscow, 1971.
15. H. Sampson, "Union of Soviet Socialist Republics," Jane's World Railways, McGraw-Hill, New York, p. 262, 1973-74.

16. J. Krautkramer and H. Krautkramer, Ultrasonic Testing of Materials, Springer Verlag, New York, p. 304-311, 1969.
17. I.L. Rikel'man and N.M. Siruk, "Effectiveness of New Methods for Detecting Flaws in Railway Tracks," The Soviet Journal of Nondestructive Testing, No. 2, p. 128-131, March-April 1974.
18. N.M. Siruk and I.L. Rikel'man, "A Comparison of the Effectiveness of Rail Inspection Units," The Soviet Journal of Nondestructive Testing, No. 2, p. 137-138, March-April 1973.
19. V.M. Bobrenko, I.I. Averbukh, and A.A. Chichugov, "Ultrasonic Method of Measuring Stresses in Parts of Threaded Joints," The Soviet Journal of Non-destructive Testing, Vol. 10, No. 1, January-February 1974.
20. V.P. Syrochkin and N.M. Rodigin, "Method of Finding the Harmonics Most Sensitive to Elastic Stresses in Structural Steel," The Soviet Journal of Nondestructive Testing, Vol. 10, No. 2, p. 132-136, March-April 1974.
21. V.M. Bobrinko and I.I. Averbukh, "Investigation of Stresses by Means of EMA Converters," The Soviet Journal of Nondestructive Testing, No. 3, p. 132-134, May-June 1971.
22. I.I. Averbukh, V.M. Bobrenko, and L.M. Kushkulei, "Estimate of Elastic and Plastic Deformations Using Surface Waves," The Soviet Journal of Non-destructive Testing, No. 6, p. 112-114, November-December 1971.
23. K. Egelkraut, "On-site Ultrasonic Rail Testing," Non-Destructive Testing, p. 297-305, 1968.
24. V.N. D'yakonov, S.A. Kolotushkin, and Yu. V. Kamshitskii, "Automatic Recording of the Configuration of a Transverse Fatigue Crack in the Head of a Rail," The Soviet Journal of Nondestructive Testing, No. 1, p. 112-113, January-February 1969.
25. A.K. Gurvich and V.A. Shchukin, "Comparative Evaluation of Methods of Measuring the Apparent Length of Defects," The Soviet Journal of Non-destructive Testing, No. 6, p. 65-70, November-December 1970.
26. A.K. Gurvich and L.I. Kuz'mina, "Investigation of Methods of Measuring the Apparent Height of Defects in the Case of Scanning with an Inclined Probe," The Soviet Journal of Nondestructive Testing, No. 6, p. 57-65, November-December 1970.
27. G.A. Krug, "Use of a Comparison Method for Measuring Coordinates in Automated Ultrasonic Testing with an Inclined Search Head," The Soviet Journal of Nondestructive Testing, No. 6, p. 87-95, November-December 1970.
28. A.K. Gurvich, "Measurement of Flaw Coordinates and Time Selection of Pulse-Echo Signals in Automated Inspection Using an Inclined Probe," The Soviet Journal of Nondestructive Testing, No. 6, p. 78-87, November-December 1970.

29. V.A. Shcherbinina, V.V. Vlasov, and B.P. Dovnar, "Calculating the Eddy-Current Component of the Field of a Defect in the High-Speed Electromagnetic Defectoscopy of Rails," The Soviet Journal of Nondestructive Testing, No. 2, p. 14-21, March-April 1973.
30. B.P. Dovnar, V.V. Vlasov, and V.A. Shcherbinina, "Experimental Investigation into the Dynamic Field of a Defect During the High Speed Electromagnetic Defectoscopy of Rails," The Soviet Journal of Nondestructive Testing, No. 2, p. 21-27, March-April 1973.
31. V.A. Shcherbinina, V.V. Vlasov, and D.P. Dovnar, "Using Ferroprobes for Testing the Rails of Electromagnetic Wagon/Defectoscopes," The Soviet Journal of Nondestructive Testing, No. 6, p. 13-21, November-December 1972.
32. E.V. Glagolev, "Some Problems Associated with Increasing the Efficiency of High-Speed Magnetic Defectoscopes," The Soviet Journal of Nondestructive Testing, No. 5, September-October 1968.
33. A.I. Butenko, I.N. Ermolov and Y.M. Shkarlet, "Electromagneto-Acoustic Nondestructive Testing in the Soviet Union," Nondestructive Testing, June 1972.
34. E.R. Dobbs, "Electromagnetic Generation of Ultrasound," Research Techniques in Nondestructive Testing, Vol. 2, R.S. Sharpe, editor, Academic Press, London and New York, p. 419-441, 1975.
35. E. Mundry, "Defect Evaluation by Ultrasonics," Nondestructive Testing, p. 290-297, October 1972.
36. Yu. M. Shkarlet and N.N. Lokshina, "Investigation of an Electromagnetic-Acoustical Converter of Shear Oscillations," The Soviet Journal of Nondestructive Testing, No. 3, p. 3-12, May-June 1970.
37. A.I. Butenko, Yu. N. Russkevich, and Yu. M. Shkarlet, "Investigation of the Acoustic Field in a Metallic Half Space with Pulsed-Electromagnetic Excitation," The Soviet Journal of Nondestructive Testing, No. 2, p. 83-88, March-April 1971.
38. N.A. Glukhov, "Directivity of an Electromagnetic Acoustic Transverse Oscillation Transducer," The Soviet Journal of Nondestructive Testing, No. 1, p. 13-19, January-February 1971.
39. G.A. Budenkov, V.N. Kvyatkovskii, Yu. V. Petrov, and N.V. Sidel'nikova, "Directional Pattern of an Electromagneto Acoustic Transmitter," The Soviet Journal of Nondestructive Testing, No. 4, p. 87-91, July-August 1971.
40. G.A. Budenkov, S.N. Bedov, and A.F. Maskaev, "Determining the Force Factors of Electromagnetic-Acoustic Probes," The Soviet Journal of Nondestructive Testing, No. 5, p. 113-115, September-October 1975.

41. G.T. Bordyugov and V.B. Pasternak, "Mathematical Simulation of the Electroacoustic Circuit of an Ultrasonic Unit," The Soviet Journal of Nondestructive Testing, No. 6, p. 26-37, November-December 1971.
42. A.I. Butenko, Yu. N. Russkevich, and Yu. M. Shkarlet, "Propagation of Ultrasonic Waves in a Metal Plate When Excited by a Pulsed Electromagnetic Wave," The Soviet Journal of Nondestructive Testing, No. 2, p. 132-136, March-April 1972.
43. S.N. Shubaev and Yu. M. Shkarlet, "General Rules for the Electromagnetic Method of Receiving Rayleigh and Lamb Waves," The Soviet Journal of Nondestructive Testing, No. 5, p. 43-75, September-October 1972.
44. N.A. Glukhov, "Some Parameters of an Electromagnetic Transducer for Transverse Ultrasonic Vibrations in Current-conducting Materials," The Soviet Journal of Nondestructive Testing, No. 4, p. 69-74, July-August 1971.
45. Yu. I. Sazonov and Yu. M. Shkarlet, "Investigation of Contactless Methods for Exciting and Recording Ultrasonic Vibrations," The Soviet Journal of Nondestructive Testing, No. 5, p. 1-12, September-October 1969.
46. G.A. Budenkov, V.N. Kvyatkovskii, and Yu. V. Petrov, "Electromagnetic-Acoustic Transducers for the Oblique-Entry Radiation of Ultrasound," The Soviet Journal of Nondestructive Testing, No. 1, p. 38-44, January-February 1974.
47. G.A. Budenkov, Z.D. Golovacheva, and Yu. V. Petrov, "Recording of Inclined Ultrasonic Waves by an Electromagnetic-acoustic Method," The Soviet Journal of Nondestructive Testing, Vol. 10, No. 2, p. 62-70, March-April 1974.
48. L.D. Kruglov, Yu. M. Shkarlet, A.A. Vertman, and G.D. Shnyrev, "Excitation of Ultrasonic Vibrations in Metals at High Temperatures by an Electromagnetic-acoustic Transducer," The Soviet Journal of Nondestructive Testing, No. 4, p. 31-37, July-August 1972.
49. S.N. Shubaev and Yu. M. Shkarlet, "Alternating Fields Generated When Rayleigh and Lamb Waves Are Picked up Electromagnetically," The Soviet Journal of Nondestructive Testing, No. 6, p. 62-68, November-December 1972.
50. S.N. Shubaev and Yu. M. Shkarlet, "Design of Transducers Used for the Electromagnetic Reception of Rayleigh and Lamb Waves," The Soviet Journal of Nondestructive Testing, No. 1, p. 81-89, January-February 1973.
51. N.A. Glukhov, V.T. Bobrov, S.S. Veremeenko, Yu. A. Druzhaev, V.N. Kolmogorov, and N.A. Lebedeva, "Electromagnetic-acoustic converters for Elastic Waveguides," The Soviet Journal of Nondestructive Testing, No. 4, p. 38-44, July-August 1972.
52. Zh. G. Nikiforenko, "Apparatus for Measuring the Properties of Rolled Sheet Metal," The Soviet Journal of Nondestructive Testing, No. 6, p. 86-95, November-December 1973.

53. G.A. Budenkov and A.F. Maskaev, "The Possibility of Inspecting Steel Products by an Electromagnetic-acoustic Method without the Removal of Scale," The Soviet Journal of Nondestructive Testing, No. 5, p. 83-87, September-October 1972.
54. A.V. Malinka, I.A. Drankin, and N.T. Kolomoets, "Electromagnetic-Acoustic Method of Inspecting Ferromagnetic Plates and Tubes," The Soviet Journal of Nondestructive Testing, No. 4, p. 44-48, July-August 1972.
55. N.A. Glukhov and V.N. Kolmogorov, "Determining the Optimal Parameters of Electromagnetic-Acoustic Transducers for Inspection of Ferrous Sheet Metal," The Soviet Journal of Nondestructive Testing, No. 1, p. 74-81, January-February 1973.
56. A.I. Butenko, A.V. Malinka, V.I. Stefarov, and Yu. M. Shkarlet, "Measuring the Thickness of Tubes by the Electromagnetic-acoustic Pulse Method," The Soviet Journal of Nondestructive Testing, No. 3, p. 7-12, May-June 1973.
57. V.V. Vlasov, V.A. Lonchak, N.A. Glukhov, I.V. Ivanov, and I.N. Runov, "Ultrasonic Monitoring of Railway Rails Set in Place Using Electromagnetic-acoustic Converters," The Soviet Journal of Nondestructive Testing, No. 3, p. 94-98, May-June 1971.
58. Sperry Railer, Annual Statistical Issue, Summer 1975, Sperry Rail Service, Danbury CT.

APPENDIX

SELECTED TRANSLATIONS OF SOVIET DOCUMENTS

This Appendix contains translated titles, abstracts, introductions and tables of contents of the literature received from the Soviets (References 1-14). The purpose is to provide the reader with information on the content of these as yet untranslated documents.

Also included in this Appendix are the abstract and the table of contents of a book, "General Course and Principles on Technical Operation of Railways," translated by Mr. Bray. Mr. Bray purchased this book during our trip. This translation is provided as an example of educational material provided by the Ministry of Transport. This book, while intended for presentation at the technical high school, appears to be a fairly complete description of U.S.S.R. railways.

Reference 1. Rail Defect Manual

RTM 321TSP-1-66, Classification of Defects and Rail Damage. This is a chart listing the designation of defects and damage of rails and the basic cause of their appearance and growth; location of defects along the length of the rails; numerical designation; schematic drawing of defect and the designation under the old classification system.

RTM/TsP-2-66, Catalog of Defects and Rail Damage. This section contains a more detailed description and causes for each type of defect.

RTM-TsP-3-66, Indications of Defective and Critically Defective Rails. This section lists rejection criteria for the defects under various conditions, i.e., gross tonnage per year, main line or branch, etc.

This publication is expected to be translated in the near future.

Reference 2. Instructions for Present Day Maintenance of Railroad Track

- Ch. I - Basic Conditions for Present Day Maintenance of Railroad Track
- Ch. II - Technical Conditions and Norms of Track Maintenance
- Ch. III - Prevention of Defects Appearing in the Track
- Appendix - Specifications of Rails, Ties, Plates and Other Components

Reference 3. Methods of Ultrasonic Inspection

Page 1 - Abstract

Present standard is used on the rails of Type R-43 (P43), R50 (P50) and R75 (P75) and establishes the use of ultrasonic method of inspection of the rail metal for the appearance of defects in the head, neck or in the zone connected with the neck, with the base of the rail, and interior defects; stratification (inclusions), blisters, concentrated liquifications, cracks, defects of electro-contact welds. Specific character of the defects by ultrasonic control is not defined.

Defects from the viewpoint of the contact method of ultrasonic inspection are not revealed.

It is necessary to put ultrasonic control into practice. The extent of control and norms of possible defects are determined by the technical requirement of the rails.

Methods of ultrasonic inspection have been established by proven application.

Reference 7. Contemporary Construction of the Superstructure of Railroad Track

Edited by Prof. V.G. Albrecht and Prof. A.F. Zolotarsky

Contents

Ch. I	Typification of the Upper Structure of the Track	p. 6
Ch. II	Rails	p. 18
Ch. III	Long Rails and Seamless Track	p. 48
Ch. IV	Intermediate Rail Fastenings	p. 75
Ch. V	Ties	p. 97
Ch. VI	Ballast Layer	p. 128
Ch. VII	Reinforced Concrete for Under-rail Bases	p. 160
Ch. VIII	Switching Translators	p. 193
Ch. IX	Structure Requirements of Track Upper Structure on on High Speed Lines	p. 229
Ch. X	Structure Requirements and Work of Track Upper Structure on Heavy Freight Lines	p. 262

Reference 8. Technical Conditions for Laying and Maintenance of Jointless Track

Responsible for Publication: V.G. Mamantov
Editor: A.I. Zakatalova
Technical Editor: O.N. Krainova
Corrector: R.A. Stonalova

I. Fundamental Situation	p. 3
II. Features of the Construction of a Seamless Track	p. 5
Plan and Profile of the Track	p. 5
Sub-grade	p. 5
Ballast layer	p. 5
Ties	p. 6
Rail strings	p. 7
Joining of Rail Strings	p. 9
Intermediate Fastening	p. 11
Seamless Track for Construction	p. 11
III. Procedures for the Laying of Seamless Track	p. 13
General Requirements	p. 13
Loading, Transportation, and Unloading of Rail Lashes	p. 14
Laying of the Rail Lashes	p. 15
Strengthening of Rail Lashes before Laying	p. 15
Length of the Leveling Rails Laid in the Track	p. 17
IV. Maintenance and Repair of Seamless Track	p. 20
General Requirements	p. 20
Supplementary Requirements for Maintenance of Seamless Track	p. 22
Features of Production of Track (Work)	p. 23
Restoration of the Integrity and Individual Replacement of the Rail Lashes	p. 26
Discharging of Thermal Stresses in Rail Lashes	p. 29
Appendix	
1. Methods of Computing of Seamless Track	p. 32
2. Estimated Temperatures of the Rail for the Network of the Railroads of USSR	p. 37
3. Example of the Estimation of Seamless Track	p. 56
4. Tables of the Largest Permissible Changes of Temperatures of Rail Lashes by Comparison with the Temperature of the Reinforcement, Defined by Conditions of Durability and Stability of the Track in Straight Sections and Curved Radii of 1000, 800, 600 and 500 meters (for the track of metal). Graphs of the Highest Permissible Changes of Temperatures of Rail Lashes by Comparison with Temperature of the Reinforcement Defined by the Conditions of Durability and Stability of Track in the straight and curved radii of 1000, 800, 600 and 500 meters (for track of metal)	p. 106
5. Table of Calculation of Temperature Regime of Rail Lashes (standard fulfilled)	p. 106
6. Table of Supplementary Instrument Stock and Equipment for Current Maintenance of Seamless Track	p. 120
7. Technological Instructions for Restoration by Contact Welding of Broken and Defective Rail Lashes for Sections of Seamless Track	p. 121

Reference 9. Seams of Welded Joints, Methods of Ultrasonic Defectoscopy

Abstract

The present standard established the methods of ultrasonic inspection for exposing cracks, non-welds, trapped gas and slag in: weld joints, corners, over-laps, T-beams welding done by arc-welding, electro-slag welding, gas-welding, gas-pressure welding, and electro-contact welding of over-lap welds in welding constructions by low carbon and light-alloyed steel, aluminum and its alloys, titanium and its alloys, lead and its alloys.

The present standard is not applied on the inspected layer or on basic metal of the welded zone.

Application of the method of ultrasonic inspection is provided for in the standards and technical conditions, which establish and provide the technical requirements for production.

Reference 10. Methods and Means of Examining the Condition of Railroad Track Superstructure

This publication has not been translated; however, it deals with scheduling, equipment used, and responsibility for track geometry measurements.

Reference 11. Construction and Test of the Operation of High Speed Track Measurement Car of the System TSNII

This publication is a description of the track geometry car and gives the physical description and capabilities of the car.

Reference 12. Problems in the Development of Rapid Movement of Trains

Contents

- | | |
|--|-------|
| 1. Introduction | p. 3 |
| 2. V.V. Chubarov - Problems of Development of Rapid Moving and Constructive Cooperation with Scientists on the Railroads | p. 7 |
| 3. N.V. Kologyazhny, B. E. Lobanov: Moscow Leningrad Line - Experimental Base of Scientific Research | p. 18 |
| 4. E. Y. Kraskovsky: Organization of Scientific Research Work at the Leningrad Institute of Railway Engineers in Cooperation with the October Railroad | p. 26 |

5. S.A. Pashinin: Assurance of Safety of High-Speed Trains p. 34
6. L.V. Rimsha: Preparation/Training for the Moscow Leningrad Line (run) to High Speed
7. L.N. Danilchik, V.A. Enguelke: Plans for Development of the Lengiprotrans as Done in the Reconstruction of the Moscow Leningrad Line p. 56
8. M.F. Verigo, A.A. Lvov, G.G. Zhelnin, U.S. Romen, V.N. Shestakov, V.A. Moloqukov, A.N. Zaharov, A.A. Verhotin: Dynamic Characteristics of High-Speed Electric Trains, Electric Cars, and the Requirements for Construction of the Tracks p. 71
9. M.B. Litvin, N.S. Dubanov: High-Speed Passenger Cars of Locomotive Traction p. 80
10. B.E. Paysahzon, A.L. Lisitsin: Development of Parameters of Electric Cars for High Speed p. 89
11. E.E. Chelnokov, B.V. Savelyev: Constructive Cooperation of Science and Production - Road to Furthering the Increase of Technical Level of Railroad Industry p. 103
12. S.V. Vershinsky, E.S. Doronin, C.L. Gamerov: Technical Requirements for Planning and Results of Dynamic Testing of High-Speed Cars p. 118
13. S.V. Amelin, G.E. Andreev, G.V. Melkov: Railroad Track for High-Speed Trains p. 135
14. M.M. Philipov (Filipov), U.S. Sihodoev, U.I. Efimenko: Reconstruction of the Station of the Moscow-Leningrad Line (run) p. 152
15. L.Z. Prasov: Determination of the Volume of Work and Cost of the Rebuilding of a Railroad Line for Preliminary Selection of Optimum Speed p. 169
16. G.E. Andreev: Determination of Basic Volume of Work of the Current Upkeep of the Railway p. 179
17. G.I. Shabalin: Scientific Research of the Railroad Subdivisions of the Railroad Industry p. 195
18. V.L. Dunenkov, S.A. Zinchenko, U.I. Speredonov: Application ABM for Estimation of Switching Reliability of Heavy Locomotives p. 200
19. G.I. Zubrilin, V.I. Guerasenkov, A.V. Plaks, G.V. Faminsky: Automation of Control of High-Speed Trains p. 206
20. A.V. Shishlyakov, G.A. Bogdanov, V.S. Dmitriyev, V.I. Skorohodov: System of a Multi-Ciphered Automatic Locomotive Signalling Aperture for High-Speed Railways p. 211
21. M.I. Ravinsky, U.I. Goroshkov: Intensification of Organization of Electrical Supply p. 223

22. V.V. Chubarov, U.V. Ulyanichev, V.E. Pavlov: Automation and Complex Mechanization of the Technological Processes at the Leningrad-Sortirovoch-Moscow Station p. 231
23. B.I. Shafirkin; Economic Problems of High-Speed Passenger Trains p. 245
24. G.I. Shabalin, A.A. Nechaev: Experimental Studies of the Public Science Research Institute of the October Railroad p. 252

Reference 13. Ultrasonic Inspection of Welded Seams

A. K. Gurvich and M. N. Ermolov

Contents

Ch. I	General Information about Ultrasonic Waves and Methods of Defectoscopy	p. 5
Ch. II	Radiation and Receiving of Ultrasonics	p. 34
Ch. III	Apparatus for Ultrasonic Inspection of the Quality of the Weld Joint	p. 56
Ch. IV	Acoustical Route of Echo Flaw Detection	p. 123
Ch. V	Acoustical Route with Inspection by Mirror-Shadow Method	p. 162
Ch. VI	Basic Parameters of Ultrasonic Inspection of Welded Joints	p. 176
Ch. VII	General Conditions of Ultrasonic Inspection of Welded Joints	p. 248
Ch. VIII	Ultrasonic Flaw Detection of Joints of Welds	p. 313
Ch. XI	Ultrasonic Flaw Detection of Angled Welded Seams	p. 336
Ch. X	Ultrasonic Flaw Detection of Joints of Contact Welding	p. 349
Ch. XI	Principles of Automatic Ultrasonic Inspection of Welded Joints	p. 363
Ch. XII	Systems of Automatic Inspection of Welded Joints	p. 418

Many of the topics in this book have been reported in the Soviet Journal of Nondestructive Testing.

Reference 14. Flaw Detection in Rails

Abstract

The physical principles and techniques of magnetic and ultrasonic flaw detection in rails are given. The intended use, working principles, layout of various rail flaw detector systems, and the procedure for working with

them are described. The methodology of rail inspections, both in the field and at railwelding facilities, is also described. The repair of flaw detection equipment on the railroads is examined.

The book has been approved by the Chief Administration of Educational Institutions of the MPS (Ministry of Transportation) as a textbook for rail transportation technical schools and by the Academic Council of the State Committee of the U.S.S.R. Council of Ministers responsible for professional-technological education as a manual for individual and brigade study by production workers. It will be helpful to maintenance-of-way workers involved in the inspection of rails.

246 figures, 19 tables, 16 entry bibliography

Book written by

A. K. Gurvich	Ch. 5; Ch. 9, Sect. 1, 2; Ch. 10, Sect. 1, 4.
V. B. Kozlov	Ch. 6, 7 and 8.
G. A. Krug	Ch. 9, Sect. 3, 5, 7, 8; Ch. 10, Sect. 2, 3, and 5.
L. I. Kuz'mina	Ch. 9, Sect. 6; Ch. 11.
I. M. Lysenko	Ch. 1; Ch. 3, Sect. 2 (pp. 83-96), 5; Ch. 12 and 13.
A. N. Matveev	Ch. 2; Ch. 3, Sect. 1, 2 (pp. 71-83).
E. I. Uspensky	Ch. 4.

TABLE OF CONTENTS

Authors' Preface

Chapter I. Servicing the Rails in the Field

1. Rail types and markings
2. Normal working condition of rails in tracks
3. Classification of rail fractures and flaws

Chapter II. Electromagnetic Flaw Detection Method

1. A brief summary of ferromagnetism
2. Basic information on the process of magnetizing ferromagnetic materials in a stable magnetic field
3. Basic character of ferromagnetic materials in a variable magnetic field
4. Magnetization features of a moving electromagnet in a contrast magnetic field
5. The magnetic method
6. The eddy current method

Chapter III. Magnetic Rail Detection (MRD) Type Flaw Detectors

1. Intended use and working principles of the flaw detectors
2. Magnetic rail flaw detector MRD-52
3. Magnetic rail flaw detector MRD-66
4. Preparation of the MRD-52 and MRD-66 and use in the field
5. Trouble-shooting the MRD-52 and MRD-66

Chapter IV. Electromagnetic Flaw Detector Car

1. Intended use and working principles of the flaw detector car
2. Layout of the flaw detector car
3. Electromagnet sensors
4. The car's powerplant and converters
5. The electric power assembly
6. Recording apparatus
7. The developing machines
8. Work of the flaw detector car on the line
9. Basic factors determining optimal working condition of the flaw detector car apparatus
10. Oscillogram interpretation
11. Troubleshooting the flaw detection apparatus
12. Basic directions for further improving flaw detector cars

Chapter V. Ultrasonic Flaw Detection Methods

1. The physical bases of ultrasonic flaw detection
2. Pulse-echo flaw detection
3. Mirror-shadow flaw detection
4. Principles for constructing ultrasonic flaw detectors.

Chapter VI. Ultrasonic Rail Flaw Detector Cart (URD-52)

1. Intended use and working principles of the flaw-detector cart
2. Electrical schematic of the flaw detector cart
3. Construction of the flaw detector cart
4. Preparation for work and inspection in the field
5. Repair and set-up of the URD-52

Chapter VII. Ultrasonic Rail Flaw Detector Cart (URD-58)

1. Intended use and working principles of the flaw detector cart
2. Electrical schematic of the flaw detector cart
3. Construction of the flaw detector cart
4. Preparation for work and inspection in the field
5. Repair and set-up of the URD-58

Chapter VIII. Ultrasonic Single-Rail Flaw Detector (URD-63)

1. Intended use and working principles of the flaw detector
2. Electric schematic of the flaw detector
3. Construction of the URD-63
4. Preparation for work on the line and evaluation of readings
5. Repair and adjustment of the URD-63

Chapter IX. The DUK-111M and DUK-131M Ultrasonic Flaw Detectors

1. Intended use and working principles
2. Electric schematic of the DUK-111M
3. Construction of the DUK-111M and preparation for work
4. Electric schematic of the DUK-131M
5. Construction of the DUK-131M
6. Preparation for work and working with the DUK-131M in the field and evaluation of readings
7. Testing and adjusting the flaw detector
8. Trouble-shooting the DUK-111M and DUK-131M

Chapter X. The UZD-NIIM-6M Ultrasonic Rail Flaw Detector Cart

1. Intended use and working principles
2. Electric schematic of the flaw detector cart
3. Construction of UZD-NIIM-6M
4. Preparing for work and working with the flaw detector
5. Trouble-shooting

Chapter XI. Inspection of Welded Joints

1. Welding defects
2. Methodology for ultrasonic inspection of welded rail joints
3. Inspection of welded rail joints using the DUK-111M, DUK-131M, and UZD-NIIM-6M
4. Flaw detectability and using inspection data to improve welding technology
5. Organization of inspection at the rail welding facility (RSP)
6. Organization of inspection of welds in the field

Chapter XII. Organization of Complex Use of Rail Flaw Detectors

1. Planning and organization of the work of flaw detectors
2. Flaw detector work sequence between stations
3. Combined work of flaw detector cars and carts

Chapter XIII. Organization of Flaw-Detector Repair

1. Traveling labs and remote flaw detector repair shops
2. Inspection and calibration at test tracks
3. Recharging points
4. Storage battery service and care

Literature

GENERAL COURSE AND PRINCIPLES ON TECHNICAL OPERATION OF RAILWAYS

M. N. Hatskelevicha, Editor
Ministry of Transport, 1974

ABSTRACT

In this book basic knowledge is presented about technical facilities of railways: works and mechanisms of the way, locomotive and car setup, automatics, remote control and communications, power supply for electrification of railways, station works and mechanisms, rolling stock contents, maintenance and operation. Also, the most important questions of organization of railway transportation and the basis for organization of moving trains are explained.

Consideration has been given to the basic demands and standards in Regulations on technical operation of railways of the U.S.S.R., ensuring precise and uninterrupted work on railways and safe movement.

The book has been approved as a quality manual for a technical high school on railway transport.

214 figures, 10 tables, 368 pages.

TABLE OF CONTENTS

- I GENERAL INFORMATION ABOUT RAILWAY TRANSPORTATION
- Chapter 1. Importance of Railway Transportation and the Operating Administration
 - Chapter 2. Principles of Technical Operation of Railways in the U.S.S.R. and Duty of Workers in Transportation
 - Chapter 3. Construction and Layout of Railway Transport Clearances
- II TRACK AND TRAVEL ORGANIZATION
- Chapter 4. Route Plan and Profile Path
 - Chapter 5. Earthen Roadbed
 - Chapter 6. Top Structure in the Track. Connection and Intersection of Tracks
 - Chapter 7. Track Organization
- III SEPARATE STATIONS OF RAILWAYS
- Chapter 8. General Information
 - Chapter 9. Mechanisms and Work of the Station
- IV AUTOMATICS, REMOTE CONTROL AND COMMUNICATIONS
- Chapter 10. Automatics and Remote Control on Railways
 - Chapter 11. Signalling
 - Chapter 12. Equipment for Signalling and Block Signalling Between Stations
 - Chapter 13. Equipment for Signalling, Interlocking and Block Signalling in Stations
 - Chapter 14. Equipment for Communications. Set Up of Signalling and Communications
- V ROLLING STOCK AND POWER SUPPLY
- Chapter 15. General Information about Locomotives
 - Chapter 16. Electrified Railways and Power Supply
 - Chapter 17. Locomotives and Self-Propelled Rolling Stock
 - Chapter 18. Locomotive Setup
 - Chapter 19. Cars
 - Chapter 20. Wheel Sets and Impact-Draught Equipment
 - Chapter 21. Brakes and Brake Equipment on Rolling Stock
 - Chapter 22. Car Setup
 - Chapter 23. Maintenance and Overhaul of Rolling Stock

- VI INSPECTION OF STRUCTURES AND MECHANISMS AND THEIR MAINTENANCE
- Chapter 24. Inspection of Structures and Mechanisms
 - Chapter 25. Organization of Maintenance of Structures and Mechanisms
 - Chapter 26. Procedure for Implementation of Maintenance, Constructional and Other Work Between Stations and at Stations
- VII ORGANIZATION OF RAILWAY TRANSPORTATION
- Chapter 27. Problems of Railway as a Result of Transportation and Traffic
 - Chapter 28. Freight Transportation
 - Chapter 29. Passenger Transportation
- VIII ORGANIZATION OF THE MOVEMENT OF TRAINS
- Chapter 30. Diagram for Movement of Trains
 - Chapter 31. Marshalling, Loading and Servicing of Trains
 - Chapter 32. Movement of Trains
 - Chapter 33. Organization of Work as a Result of Guaranteeing Security of Movement on Railways
- IX MATERIAL ORGANIZATION OF RAILWAYS
- Chapter 34. Organization of Material, Technical Supplies
 - Chapter 35. Warehouse Material