

UMTA-MA-06-0025-81-5  
DOT-TSC-UMTA-81-76

# The Status of Advanced Propulsion Technology in Japan

Vilas D. Nene

OAO Corporation  
1200 New Hampshire Ave., N.W., No. 420  
Washington DC 20036

March 1982  
Final Report

This document is available to the public  
through the National Technical Information  
Service, Springfield, Virginia 22161.



U.S. Department of Transportation  
**Urban Mass Transportation  
Administration**

Office of Technology Development and Deployment  
Office of Rail and Construction Technology  
Washington DC 20590

NOTICE

This document is disseminated under the sponsorship of the Department of Transportation in the interest of information exchange. The United States Government assumes no liability for its contents or use thereof.

NOTICE

The United States Government does not endorse products or manufacturers. Trade or manufacturers' names appear herein solely because they are considered essential to the object of this report.

1. Report No. UMTA-MA-06-0025-81-5		2. Government Accession No.		3. Recipient's Catalog No.	
4. Title and Subtitle THE STATUS OF ADVANCED PROPULSION TECHNOLOGY IN JAPAN				5. Report Date March 1982	
				6. Performing Organization Code DTS-722	
7. Author(s) Vilas D. Nene				8. Performing Organization Report No. DOT-TSC-UMTA-81-76	
9. Performing Organization Name and Address OAO Corporation* 1200 New Hampshire Ave., N.W., #420 Washington, D.C. 20036				10. Work Unit No. (TRAIS) UM204/R2616	
				11. Contract or Grant No. DTRS-57-81-C-00033	
12. Sponsoring Agency Name and Address U.S. Department of Transportation Urban Mass Transportation Administration Office of Technology Development and Deployment Washington DC 20590				13. Type of Report and Period Covered Final Report 1/15/1981 - 7/15/1981	
				14. Sponsoring Agency Code UTD-30	
15. Supplementary Notes *Under contract to:		U.S. Department of Transportation Research & Special Programs Administration Transportation Systems Center, Cambridge MA 02142			
16. Abstract This report describes the efforts of Japanese transit industry --manufacturers and transit operators-- in the area of advanced propulsion systems for urban rail vehicles. It presents different chopper system designs, new ac drive developments, various commercial frequency and audio frequency signalling systems, investigations of potential electromagnetic interference problems and possible countermeasures. Finally six Japanese transit systems using chopper cars are described in some detail in Appendix A and a widely used commutation circuit is described in Appendix B.					
17. Key Words Electromagnetic interference, transit car propulsion, signalling, choppers, and inverters.			18. Distribution Statement Document is available to the Public through the National Technical Information Service, Springfield, Virginia 22161		
19. Security Classif. (of this report) Unclassified		20. Security Classif. (of this page) Unclassified		21. No. of Pages 86	22. Price

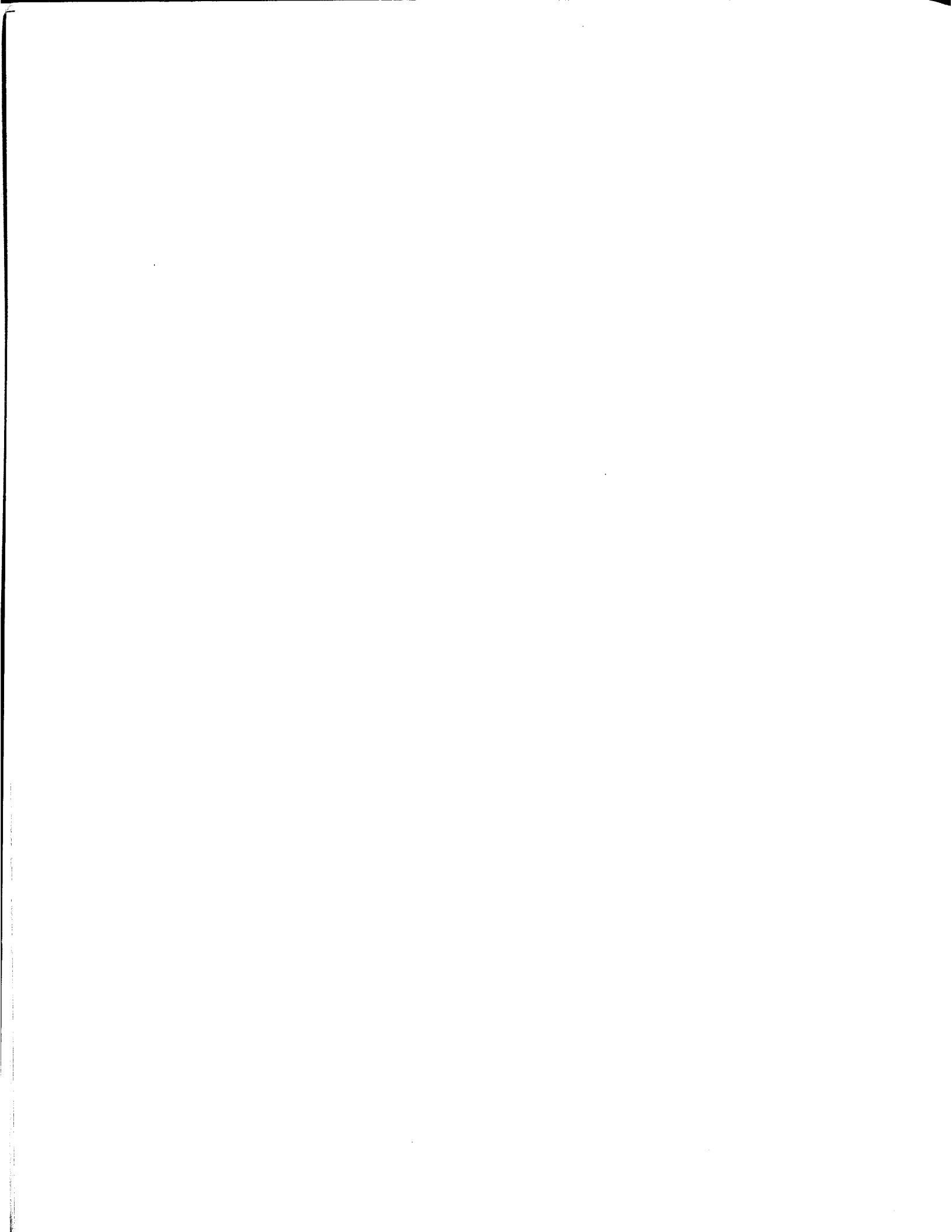

## PREFACE

The author wishes to express his sincere gratitude for the assistance provided by the following organizations: Hitachi, Mitsubishi, Toshiba, Nippon Signal, Kyosan Electric, Sapporo Subway, TRTA (Tokyo), Osaka Subway, Nagoya Subway, Kobe Subway and Kyoto Subway.

Specifically, the author is most grateful to these organizations for the warm welcome extended to him during his visits, for the total access to technical information so generously provided, and for the long hours spent by their technical staff members. Such a report is clearly impossible without such cooperation.

The author is also deeply indebted to Mr. Yukinobu Mizuno, Deputy Director, Japan Railway Technical Service (JARTS), Tokyo, for accompanying him and spending endless hours on the above visits.

In addition, the author wishes to thank Mr. Stephen S. Teel of U.S. DOT/UMTA and Mr. Louis A. Frasco of U.S. DOT/TSC for their continued interest in and strong support of this work.

## METRIC CONVERSION FACTORS

### Approximate Conversions to Metric Measures

Symbol	When You Know	Multiply by	To Find	Symbol
<b>LENGTH</b>				
in	inches	*2.5	centimeters	cm
ft	feet	30	centimeters	cm
yd	yards	0.9	meters	m
mi	miles	1.6	kilometers	km
<b>AREA</b>				
in <sup>2</sup>	square inches	6.5	square centimeters	cm <sup>2</sup>
ft <sup>2</sup>	square feet	0.09	square meters	m <sup>2</sup>
yd <sup>2</sup>	square yards	0.8	square meters	m <sup>2</sup>
mi <sup>2</sup>	square miles	2.6	square kilometers	km <sup>2</sup>
	acres	0.4	hectares	ha
<b>MASS (weight)</b>				
oz	ounces	28	grams	g
lb	pounds	0.45	kilograms	kg
	short tons (2000 lb)	0.9	tonnes	t
<b>VOLUME</b>				
tsp	teaspoons	5	milliliters	ml
Tbsp	tablespoons	15	milliliters	ml
fl oz	fluid ounces	30	milliliters	ml
c	cups	0.24	liters	l
pt	pints	0.47	liters	l
qt	quarts	0.95	liters	l
gal	gallons	3.8	liters	l
ft <sup>3</sup>	cubic feet	0.03	cubic meters	m <sup>3</sup>
yd <sup>3</sup>	cubic yards	0.76	cubic meters	m <sup>3</sup>
<b>TEMPERATURE (exact)</b>				
°F	Fahrenheit temperature	5/9 (after subtracting 32)	Celsius temperature	°C

\*1 in = 2.54 (exactly). For other exact conversions and more detailed tables, see NBS Misc. Publ. 286, Units of Weights and Measures, Price \$2.25, SD Catalog No. C13.10:286.

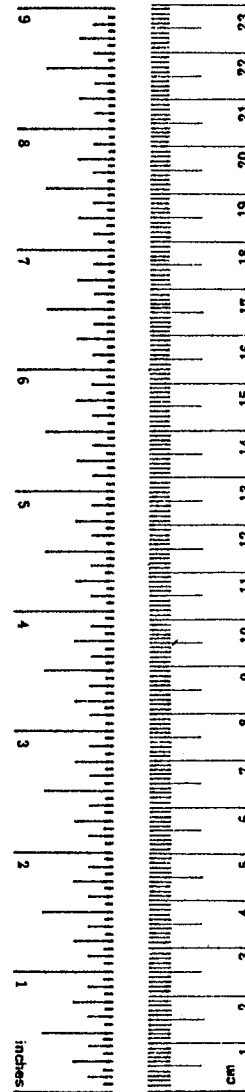

### Approximate Conversions from Metric Measures

Symbol	When You Know	Multiply by	To Find	Symbol
<b>LENGTH</b>				
mm	millimeters	0.04	inches	in
cm	centimeters	0.4	inches	in
m	meters	3.3	feet	ft
m	meters	1.1	yards	yd
km	kilometers	0.6	miles	mi
<b>AREA</b>				
cm <sup>2</sup>	square centimeters	0.16	square inches	in <sup>2</sup>
m <sup>2</sup>	square meters	1.2	square yards	yd <sup>2</sup>
km <sup>2</sup>	square kilometers	0.4	square miles	mi <sup>2</sup>
ha	hectares (10,000 m <sup>2</sup> )	2.5	acres	
<b>MASS (weight)</b>				
g	grams	0.035	ounces	oz
kg	kilograms	2.2	pounds	lb
t	tonnes (1000 kg)	1.1	short tons	
<b>VOLUME</b>				
ml	milliliters	0.03	fluid ounces	fl oz
l	liters	2.1	pints	pt
l	liters	1.06	quarts	qt
l	liters	0.26	gallons	gal
m <sup>3</sup>	cubic meters	35	cubic feet	ft <sup>3</sup>
m <sup>3</sup>	cubic meters	1.3	cubic yards	yd <sup>3</sup>
<b>TEMPERATURE (exact)</b>				
°C	Celsius temperature	9/5 (then add 32)	Fahrenheit temperature	°F

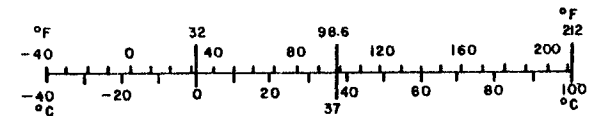

## TABLE OF CONTENTS

	<u>PAGE</u>
EXECUTIVE SUMMARY . . . . .	ix
1. INTRODUCTION . . . . .	1
2. CHOPPER CONTROLLED DC DRIVES . . . . .	2
2.1 General Background . . . . .	2
2.2 Signaling Systems . . . . .	3
2.3 Electromagnetic Compatibility (EMC) Considerations . . . . .	6
2.3.1 Chopper Harmonics and Induction from Third Rail . . . . .	7
2.3.2 Induced Noise due to Flux under the Car . . . . .	8
2.3.3 Design Changes to reduce Noise of Chopper Cars . . . . .	10
2.4 Advanced Design Features . . . . .	12
2.5 Maintenance of Chopper Equipment . . . . .	15
3. DEVELOPMENT OF INVERTER CONTROLLED AC DRIVES . . . . .	19
4. CONCLUSIONS . . . . .	22
APPENDIX A. DETAILS OF SOME OPERATING TRANSIT SYSTEMS . . . . .	23
A.1 Sapporo Subway . . . . .	23
A.1.1 Operating Lines . . . . .	23
A.1.2 Traffic Density . . . . .	23
A.1.3 Rolling Stock . . . . .	25
A.1.4 Energy Savings By Regeneration . . . . .	27
A.1.5 Signalling System . . . . .	27
A.1.6 Equipment Noise Levels . . . . .	28
A.1.7 Electromagnetic Compatibility of Chopper Equipment . . . . .	28
A.1.8 Application of Advanced Design Features . . . . .	30
A.2 Teito Rapid Transit Authority (TRTA), Tokyo . . . . .	31
A.2.1 Chiyoda Line . . . . .	31
A.2.2 Yurakucho Line . . . . .	35
A.2.3 Hanzomon Line . . . . .	37
A.2.4 Energy Savings By Regeneration . . . . .	38
A.2.5 Signalling System . . . . .	38
A.2.6 Electromagnetic Compatibility of Chopper Equipment . . . . .	39
A.2.7 Application of Advanced Design Features . . . . .	39

TABLE OF CONTENTS (cont.)

	<u>PAGE</u>
A.3 Nagoya Subway . . . . .	41
A.3.1 Operating Lines . . . . .	41
A.3.2 Traffic Density . . . . .	43
A.3.3 Rolling Stock . . . . .	43
A.3.4 Energy Savings By Regeneration . . . . .	46
A.3.5 Signalling System . . . . .	46
A.3.6 Electromagnetic Compatibility of Chopper Cars . . . . .	47
A.3.7 Application of Advanced Design Features . . . . .	50
A.4 Osaka Subway . . . . .	51
A.4.1 Operating Lines . . . . .	51
A.4.2 Chopper Controlled Cars . . . . .	53
A.4.3 Signalling System . . . . .	55
A.4.4 Electromagnetic Compatibility of Chopper Cars . . . . .	56
A.4.5 Application of Advanced Technology . . . . .	57
A.5 Kobe Subway . . . . .	58
A.5.1 Operating Line . . . . .	58
A.5.2 Rolling Stock . . . . .	58
A.5.3 Inverter Substations and Energy Savings . . . . .	61
A.5.4 Signalling System . . . . .	65
A.6 Kyoto Subway . . . . .	66
A.6.1 Planned Network . . . . .	66
A.6.2 Rolling Stock . . . . .	66
A.6.3 Substation Equipment . . . . .	69
A.6.4 Signalling System . . . . .	69
A.6.5 Application of Advanced Technology . . . . .	69
APPENDIX B. Operation of A Commutation Circuit . . . . .	71
REFERENCES . . . . .	75



## LIST OF FIGURES

FIGURE NO.	TITLE	PAGE NO.
1	Onboard Filtering. . . . .	9
2	Grade Crossing Protection. . . . .	9
3	Use of Twisted Cables. . . . .	11
4	Car Performance in Powering. . . . .	13
5	Car Performance in Braking . . . . .	14
6	Power Circuit of AC Drive. . . . .	20
A-1	Sapporo Subway Network . . . . .	24
A-2	6000 Series Cars on Tozai Line . . . . .	26
A-3	Location of System Hardware. . . . .	29
A-4	TRTA Lines with Chopper Cars . . . . .	33
A-5	6000 Series Cars for Chiyoda Line. . . . .	34
A-6	7000 Series Cars for Yurakucho Line. . . . .	36
A-7	8000 Series Cars for Hanzomon Line . . . . .	36
A-8	Planned Network for Nagoya Subway. . . . .	42
A-9	5000 Series Cars for Line 1. . . . .	44
A-10	3000 Series Cars for Line 3. . . . .	44
A-11	Operating Lines of Osaka Subway. . . . .	52
A-12	10 Series Cars for Line 1. . . . .	54
A-13	Planned Network for Kobe Subway. . . . .	59
A-14	1000 Series Cars for Seishin Line. . . . .	60
A-15	Profile of Seishin Line. . . . .	62
A-16	Power Supply Schematic at Kobe Subway. . . . .	63
A-17	Planned Network for Kyoto Subway . . . . .	67
A-18	20 Series Cars for Kyoto Subway. . . . .	68
B-1	Commutation Circuit. . . . .	72
B-2	Commutation Process. . . . .	72
B-3	Waveforms during Commutation . . . . .	74

## LIST OF TABLES

TABLE NO.	TITLE	PAGE NO.
1	Summary of Chopper Cars. . . . .	4
2	Maintenance and Inspection Schedule. . . . .	15
3	Details of Chopper Inspection. . . . .	16-17
4	Chopper Car Failures at TRTA . . . . .	18
A-1	Equipment Noise Levels . . . . .	28
A-2	Characteristics of TRTA Lines. . . . .	32
A-3	Train Headways at Nagoya . . . . .	43
A-4	Characteristics of Chopper Cars. . . . .	45
A-5	Signalling Frequencies for Lines 2 and 4 at Nagoya. . . . .	47
A-6	Energy Consumption at Kobe Subway. . . . .	64
A-7	Voltage and Current Harmonics on 77 kV Line of Kansai Electric. . . . .	65

## EXECUTIVE SUMMARY

The development of chopper controlled dc drives for urban and commuter rail vehicles began in the early 1960's in Japan when small units of variable frequency choppers were tested on the Ginza and Hibiya lines of Teito Rapid Transit Authority (TRTA), Tokyo. Since then, chopper technology has been advanced very rapidly, and choppers of advanced design using reverse conducting thyristors, automatic variable field control, and freon cooling are being increasingly introduced in Japan.

Chopper controlled cars are in revenue service on subways in Tokyo, Sapporo, Nagoya, Osaka, and Kobe city. They will also be introduced in service in Kyoto and Fukuoda when these subways begin revenue service later this year. Chopper drives are also in service on many suburban lines of JNR and other private railroads as well as on streetcars in Hiroshima and Nagasaki. During initial tests on earlier prototype chopper equipment, electromagnetic interference problems were encountered similar to those experienced in the United States at CTA (Chicago) and MARTA (Atlanta). Subsequently, the chopper designs have gone through several design changes over the years to reduce the EM noise caused by chopper cars in track circuits. These include improved packaging and topologies, shielding of components and cables, use of fixed frequency chopper design, etc.

The transit vehicles and other equipment go through a considerable amount of scheduled inspection and preventive maintenance to assure safe and reliable system operation. This includes a 48-hour and 2-month inspection, and 2-year and 4-year overhaul of car equipment. These maintenance and inspection (M & I) requirements are, in fact, mandated by the Federal Government and are based on the study of equipment failure data. They are also updated from time to time as necessary. These M & I guidelines are not based on classical analysis of cost/benefit ratio but strictly on safety considerations. As a result of these efforts, service interruptions or long delays due to equipment failure are quite uncommon in Japan. For example, there has not been a single such interruption or delay since 1978 due to chopper failure in Tokyo.

Use of computerized automatic train inspection is also almost universal in Japan. The main computer is housed in an air-conditioned enclosure, and connecting multipin adapters are permanently wired and brought to the bay where a train is parked. All the cars in a train are hooked onto the system via these adapters and the train is inspected within about half an hour. A detailed test report is printed if necessary.

Inverter substations are also in use in Kobe, Nagoya, and other cities to assure line receptivity to regenerated power during vehicle braking. Other developments include inverter controlled ac drives, flywheel storage at substations, use of fiber optics, etc.

The R & D programs undertaken by the Japanese companies and their client railroads and transit systems are clearly goal-oriented and very methodical. Every new concept goes through a long series of prototype and pre-series tests before it is committed to production.

This report describes the status of advanced propulsion technology in Japan. It presents different chopper system designs, investigations of potential electromagnetic interference problems with track circuits, and possible countermeasures. Finally, six Japanese transit systems using chopper cars are described in some detail in an appendix.

## 1. INTRODUCTION

This study of Japanese experience with chopper controlled dc drives for urban rail vehicles is a part of STARS program of the Urban Mass Transportation Administration. The STARS program - Subsystem Technology Applications to Rail Systems - covers different areas including vehicle systems, wayside equipment, etc., and focuses on the cost effectiveness and near term application of rail transit technology.

Reports published earlier under this STARS program have already investigated advanced propulsion system concepts, electromagnetic compatibility of chopper and inverter drives (European and U.S. equipment in particular), various track circuit configurations, different modes of interference, etc. The reader is, therefore, assumed to be familiar with this earlier work.

This report describes the efforts of the Japanese transit industry - manufacturers and transit operators - in the area of advanced propulsion systems for urban rail vehicles. It presents different chopper system designs, new ac drive developments, various commercial frequency and audio frequency signalling systems, investigations of potential electromagnetic interference problems and possible countermeasures. Other related topics such as equipment reliability and maintenance are also discussed.

Finally, six Japanese transit systems using chopper controlled cars are described in some detail in Appendix A, and the commutation circuit of these choppers is described in Appendix B.

## 2. CHOPPER CONTROLLED DC DRIVES

The development of chopper controlled dc drives for urban and commuter rail vehicles began in the early 1960's in Japan when small units of variable frequency choppers were tested on the Ginza and Hibiya Lines of Teito Rapid Transit Authority (TRTA), Tokyo. Since then chopper technology has been advanced very rapidly and chopper cars using advanced design features such as reverse conducting thyristors, automatic variable field (AVF) control and two phase freon cooling are being increasingly introduced in Japan.

### 2.1 General Background

There are many subway and streetcar systems currently operating or under construction in Japan. Six cities are currently served by subways - Sapporo, Tokyo, Nagoya, Osaka, Kobe, Yokohama - and except for Sapporo (rubber tired) all are urban rail systems. Two other subways - Kyoto and Fukuoka - are scheduled to open this year. Many other cities such as Sapporo, Hiroshima and Nagasaki operate street car service. Also, many other private railroads provide suburban service. These include, among others, Hanshin, Hankyu, Keihin, Keio, Kinki Nippon, Nankai, Odakyu, Tokyu, etc. Close to the cities many of these railways and the local subways run reciprocal through service. During these runs the subway cars travel on tracks of the private railways, and vice versa. Each of the rolling stocks, therefore, has to be compatible with the non-vehicle equipment of both the systems.

Over the past fifteen years (armature) chopper controlled dc drives have been introduced on the following systems:

Subways:	Tokyo (TRTA and TMTB lines)
	Sapporo
	Nagoya
	Osaka
	Kobe
	Kyoto (to be opened soon)
	Fukuoka (to be opened soon)

Suburban Lines:     Hankyu  
                      Hanshin  
                      Nankai  
                      Kinki Nippon  
                      JNR

Street cars:         Hiroshima  
                      Nagasaki

Some of the characteristics of these chopper systems are summarized in Table 1. Two-phase power circuit and liquid freon cooling are becoming standard design features of choppers in subway and suburban service in Japan. AVF control is available at the option of customers.

## 2.2 Signalling Systems

Several types of track circuits are used for train detection and ATC systems. These include power frequency circuits using 25, 30, 50, 60, 83 1/3, 100, 120 Hz and audio frequency circuits using 2-25 kHz. Also, track circuits with continuously welded rail as well as single and double insulated rails are used. Many suburban lines operated by private railways use audio frequency overlay circuits at grade crossings. With reciprocal services on lines using different signalling systems, any new equipment introduced onboard subway cars has to be compatible with several systems.

Signalling and ATC frequencies used at Sapporo, TRTA, Nagoya, Kyoto, Osaka, and Kobe have been given in Appendix A. Similar data for some other systems is given below:

- o Tokyo Metropolitan Transportation Bureau  
Train detection: 9.2, 10.6, 12.4 kHz in stations and  
14.8, 16.4, 18.6 kHz between stations, modulated  
at 36 Hz

TABLE 1  
Summary of Chopper Cars  
(Reproduced from Reference 1)

Operating Line	Hanshin	T.R.T.A	Sanyou	Hankyu	T.R.T.A	Nankai	Sapporo	Osaka	Kobe	Nagoya	Sapporo
Power Supply System	D.C. 1500 V Overhead line (O.H.L.)	D.C. 1500 V O.H.L.	D.C. 1500 V O.H.L.	D.C. 1500 V O.H.L.	D.C. 1500 V O.H.L.	D.C. 1500 V O.H.L.	D.C. 1500 V O.H.L. (Rubber tired car)	D.C. 750 V 3rd rail	D.C. 1500 V O.H.L.	D.C. 1500 V O.H.L.	D.C. 750 V 3rd rail (Rubber tired car)
Series	7000	6000	270	2200	7000	8000	6000	10	1000	3000	3000
Control Capacity per Chopper Device (Rating of traction motor x No.)	110 kW x 8	145 kW x 8	52.5 kW x 4	135 kW x 8	150 kW x 8	155 kW x 8	70 kW x 16	130 kW x 8	130 kW x 8	135 kW x 8	110 kW x 8
Cooling System of thyristor elements	Forced Air	Forced Air	Forced Air	Forced Air	Forced Air	Forced Air	Forced Air	Fron Evaporation	Forced Air	Forced Air	Forced Air
Frequency	350 HZ	660 HZ	400 HZ	350 HZ	660 HZ	384 HZ	400 HZ	400 HZ	350 HZ	486 HZ	400 HZ
No. of Phase	2	3, 2	2	2	2	2	2	2	2	2	2
Brake System	Air	Regenerative	Air	Regenerative	Regenerative	Regenerative	Regenerative	Regenerative	Regenerative	Regenerative	Regenerative
No. of Cars	24	210	1	8	100	6	80	72	32	32	8
First Year of Operation	'70	'71	'72	'72	'74	'75	'76	'76	'76	'77	'78

Operating Line	Kintetsu	J.N.R	Toei	Hankyu	Kyoto	Nagoya	Hanshin	Hiroshima	Nagasaki	Fukuoka	T.R.T.A
Power Supply System	D.C. 1500 V O.H.L.	D.C. 1500 V O.H.L.	D.C. 1500 V O.H.L.	D.C. 1500 V O.H.L.	D.C. 1500 V O.H.L.	D.C. 600 V 3rd rail	D.C. 1500 V O.H.L.	D.C. 600 V O.H.L.	D.C. 600 V O.H.L.	D.C. 1500 V O.H.L.	D.C. 1500 V O.H.L.
Series	3000	201	10-000	2300	10	5000	5000	5000	2000	1000	8000
Control Capacity per Chopper Device (Rating of traction motor x No.)	165 kW x 8	150 kW x 8	165 kW x 8	150 kW x 8	130 kW x 8	95 kW x 8	75 kW x 8	120 kW x 1	120 kW x 1	150 kW x 8	165 kW x 8
Cooling System of thyristor elements	Fron Evaporation	Forced Air	Forced Air	Forced Air	Fron Evaporation	Fron Evaporation	Fron Evaporation	Forced Air	Fron Evaporation	Forced Air	Fron Evaporation
Frequency	482 HZ	600 HZ	470 HZ	512 HZ	482 HZ	400 HZ	350 HZ	486 HZ	243 HZ	660 HZ	660 HZ
No. of Phase	2	2	2	2	2	2	2	1	1	2	2
Brake System	Regenerative	Regenerative	Regenerative	Regenerative	Regenerative	Regenerative	Regenerative	Regenerative	Air	Regenerative	Regenerative
No. of Cars	4	10	60	3	36	6	4	3	2	48	40
First Year of Operation (*)	'79	'79	'79	'79	('80)	'80	'80	'80	'80	('80)	('80)

Note (\*) First Year of Testing



ATC Frequencies: 1015, 1025, 1035, 1065, 1075, 1085 Hz  
Maximum block length is 500m. Pickup threshold at the relay is 15 mV and the normal signal is 40-50 mV.

- Tokyu Railway

Train detection: 11.8, 13.3, 15.4, 16.8 kHz in stations and  
13.3, 15.4, 16.8 kHz between stations, modulated  
at 20 Hz

ATC Frequencies: 3450Hz (up), 3750Hz (down) modulated 23, 28, 35,  
42, 64 Hz to denote speeds of 75, 55, 40, 25, 0  
km/h.

- Nankai Railway

Train detection: 2.0, 2.2, 2.4, 2.6, 2.8, 3.0 kHz modulated at 16,  
22, 28, 36 Hz for wayside signals

No onboard ATC

Pickup threshold at the relay 80 mV. Nominal signal at the relay  
200-300 mV

- Fukuoka Subway

This system is very similar to Nagoya subway Line 3. ATC code rates  
are identical but speeds corresponding to these codes are slightly  
different.

- Yokohama Subway

Double insulated rail circuits are used.

Train detection: 3150 Hz, 3750 Hz

ATC Frequencies: Code rates 16, 23, 28, 35, 42, 64, 77 Hz  
correspond to speeds of 90, 70, 60, 50, 40, 25, 0  
Km/h

Minimum signal level is 140 mA and the maximum block length is 500  
meters.

- JNR Suburban Lines

Double insulated rail circuits are used

Train detection: 2850, 3450 Hz (up) 3150, 3750 Hz (down)

ATC Frequencies: Code rates 16, 23, 28, 35, 42, 64 Hz  
Correspond to speeds of 90, 75, 55, 40, 25, 0  
Km/h

Minimum signal level is 140mA and the maximum block length is 500  
meters.

In addition to these and other subway track circuits, audio frequency overlay circuits are used for grade crossing protection on suburban lines. These circuits use carrier frequencies in the range 2-11 kHz and frequency modulation over 20-60 Hz. Grade crossing protection circuits using unmodulated CW type signal are also used in some places. A typical grade crossing protection circuit is described later.

### 2.3 Electromagnetic Compatibility (EMC) Considerations <sup>2-7</sup>

There are basically three ways in which onboard and wayside equipment can possibly interfere with normal operation of track circuits used for train detection and ATC system. These are:

1. High frequency components of propulsion current such as resulting from substation harmonics and chopper harmonics return via the running rails which also carry the signalling currents. This component of noise current is called "conducted noise" because the running rails present a common ohmic path between the propulsion circuit and the signalling circuit.
2. The running rails are in proximity and hence electromagnetically coupled to the third rail. Voltages having high frequency harmonic components are, therefore, induced in the track circuits when the third rail carries high frequency currents. Overhead catenary is not so close, and more symmetrically located with respect to the running rails. This type of induced noise can, therefore, be ignored with catenary systems.
3. The current carrying reactors, cables and other components under a car create a magnetic flux density distribution which is linked with the track circuits. Noise voltages are, therefore, induced in loop coils directly under the car. These loop coils may be the receiving coils of grade crossing protection circuit, or a loop formed by the running rails and the inner wheel-axle sets of a car. Such induced noise voltages may cause potential interference with normal circuit operation.

### 2.3.1 Chopper Harmonics and Induction from Third Rail

The conducted noise and the noise induced from the third rail can be reduced by reducing the levels of harmonic currents in the propulsion current. There are two factors which impact on these harmonic levels.

#### Onboard LC Filter

An LC filter is used to attenuate the chopper harmonics as shown in Figure 1. The harmonics in the third rail current  $i_s$  are given by

$$i_{sn} = \left\{ \frac{1}{n^2 (fc/fo)^2 - 1} \right\} i_{chn}$$

so that the harmonic levels are reduced when the ratio  $fc/fo$  (chopper frequency/filter frequency) is increased. Most of the choppers used on Japanese subways are of two phase design so that the effective chopper frequency is doubled. The attenuation of high frequency components is, therefore, very effective.

#### Starting Techniques for Choppers

Except for a very few earlier designs, the choppers in current revenue service are all fixed frequency choppers. The minimum ON period for a chopper is restricted to up to several hundred microseconds depending on the turn off time for the thyristors. During vehicle starting, the traction motor speed and hence the armature back emf is zero. Hence, even with the minimum ON period, the starting inrush of current and the resulting motor torque are normally limited by

- sweep frequency starting,
- pulse skipping during start, and
- absolutely fixed frequency operation by introducing a resistance in the circuit at start.

With sweep frequency and pulse-skip starting, continuously variable and subharmonic frequency components are present in propulsion current.

Choppers of not so recent designs in revenue service today use all the above methods as well as preprogrammed stepped frequency starting in place of pulse skipping on an as-required basis. For example, choppers in use at TRTA, Nagoya, Hankyu, etc. used additional resistance in the circuit at start; choppers for use at Fukuoka will use pulse skipping; and Hanshin and JNR choppers use programmed 2 step and 3 step starting respectively.

Choppers of recent design, however, use reverse conducting thyristors with shorter turn-off times. A minimum of up to 150  $\mu$ s of ON times are then possible which amounts to a duty cycle of 3 percent for a 200 Hz chopper. An absolutely fixed frequency operation of chopper is, therefore, possible without introducing additional resistance in the circuit. Although jerk is within limits, independent jerk control is then lost for a short interval during starting because the traction motor current cannot be independently controlled as long as the chopper duty cycle is held at a minimum. Choppers designed for use in Osaka, Kobe, Sapporo and Tokyo (TMTB) are of this type of fixed frequency choppers.

### 2.3.2 Induced Noise due to Flux under the Car

The components that cause leakage flux under a car are:

- o Commutating reactor
- o Open cables
- o Air cored motor reactor
- o Air cored filter reactor

With introduction of choppers on different systems in Japan, potentially severe interference situations were encountered earlier and the chopper equipment designs have evolved resulting in significant reduction of noise levels.

One of the most significant EMC problems experienced in Japan was that of EM noise induced in receiving coil of AF overlay circuits used for grade crossing protection. One such track circuit is shown in Figure 2. With an

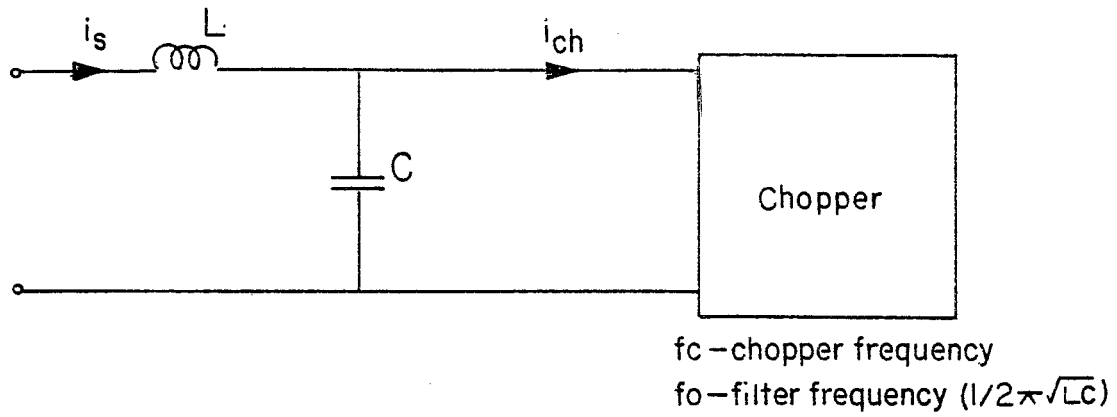
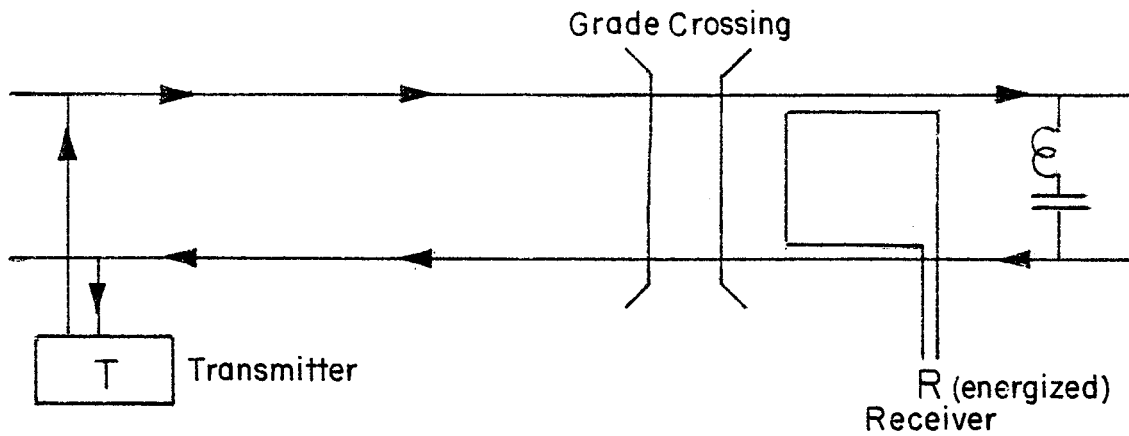
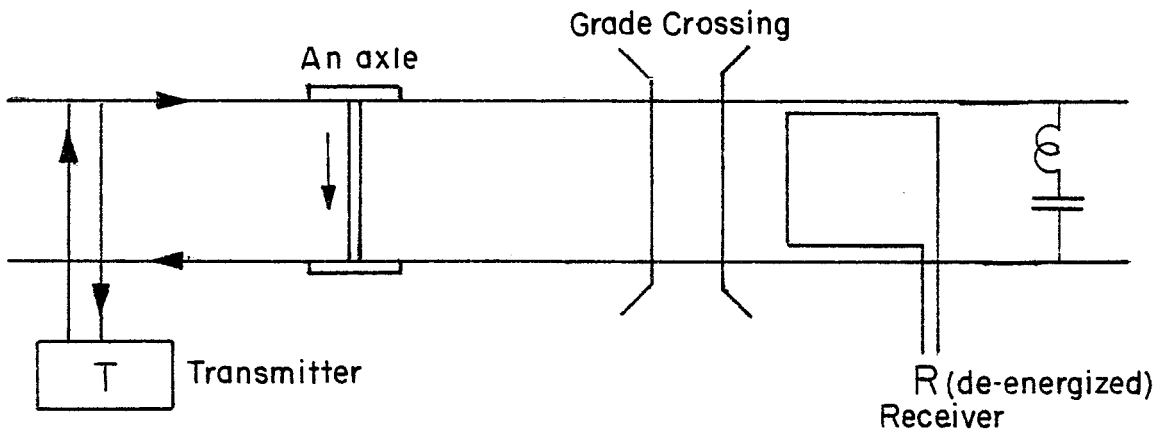

FIGURE 1. ONBOARD FILTERING



A. UNOCCUPIED



B. OCCUPIED

FIGURE 2. GRADE CROSSING PROTECTION

unoccupied circuit, i.e., when there is no train in the length of the circuit, the receiving coil receives the transmitted signal and the track relay is energized. The gate is held open whenever the relay is energized. If, however, a train enters the track circuit and is travelling towards the grade crossing, the transmitted signal is interrupted, the relay is deenergized and gate is closed. If there is a significant flux level under a car, noise voltages can be induced in the receiving coil when the car is just above it, causing the relay to be energized. This, in turn, would cause the gate to be opened even if the entire train has not cleared the length of the overlay circuit. Such malfunction of grade crossing protection circuit was in fact observed when 10000 series chopper cars of Tokyo Metropolitan Transportation Bureau (TMTB) running on Shinjuku Line were introduced in reciprocal through service on the Keio Line just beyond the Shinjuku Line <sup>3</sup>. Similar interference was also experienced on Hankyu Lines with their 5300 series chopper cars.

### 2.3.3 Design Changes to Reduce Noise of Chopper Cars

Several design changes have been effected over the years to reduce electromagnetic noise caused by chopper cars. It is not possible, and many times not necessary to use all of these design features for every application of chopper drives. These are used on an as-required basis depending on the EM compatibility requirements imposed by non-propulsion equipment in use on the lines. These design changes include:

- o Use of torroidal commutating reactors
- o Use of silicon steel shielding of motor reactors
- o Use of silicon steel or copper plates for shielding commutating reactors
- o Transverse mounting of filter and motor reactors
- o Aluminum shielding for cables between chopper box and reactors
- o Use of aluminum or steel sheet covers for chopper boxes
- o Use of twisted cables in chopper circuit as shown in Figure 3.

In addition to these design options, sometimes operating thresholds of track relays were increased and time delays introduced in track circuits to ensure EM compatibility of chopper equipment.

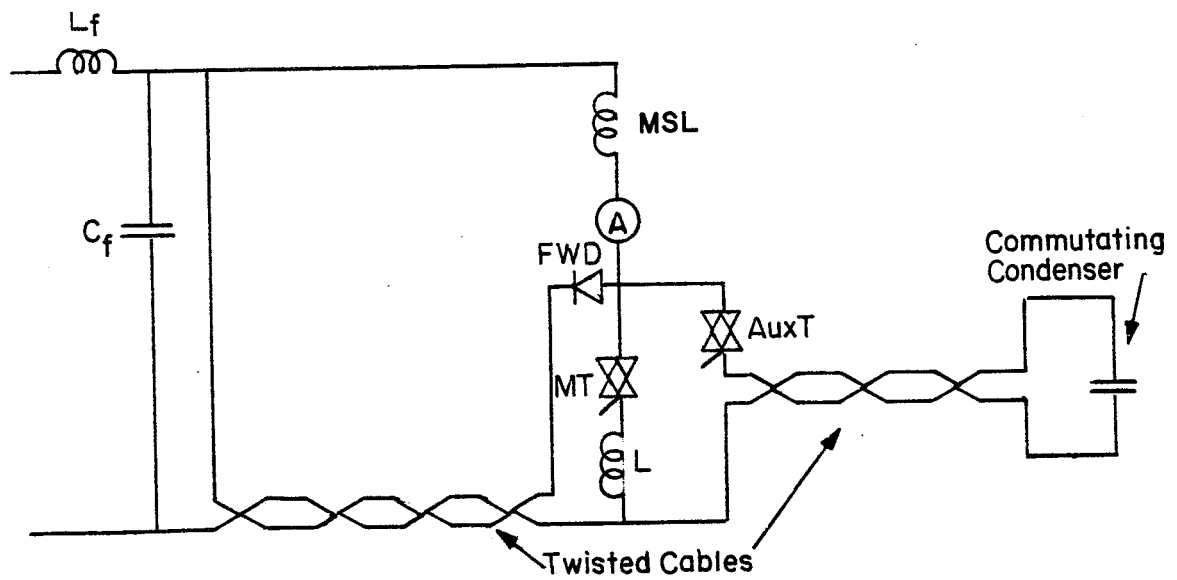

FIGURE 3. USE OF TWISTED CABLES

## 2.4 Advanced Design Features

Several advanced design features have been employed in the new choppers in order to improve equipment performance, reliability and maintainability. These include: <sup>8</sup>

### 1. Use of reverse conducting thyristors

Using a reverse conducting thyristor in place of a thyristor and a diode in reverse parallel connection results in a simple circuit with reduced part count. Also, choppers can be designed for fixed frequency operation from start without additional resistances. Reduced part count and improved simplified circuits result in better reliability.

### 2. Automatic Variable Field (AVF) Control

Here a split field traction motor is used with only one winding in series with the armature. The other is connected in series with the free wheeling diode for powering and in series with the chopper for braking. The effective field current of the motor is thus continuously varied with the chopper duty cycle.

With this AVF control, maximum braking effort is available for extended speed range without increasing the rated speed of the motor. Figures 4 and 5 show the performance of three series of TRTA chopper cars (see Appendix). Only the 6000 series cars for Chiyoda Line have conventional field weakening control. The other two cars - 7000 series for Yurakucho Line and 8000 series for Hanzomon Line - use AVF control.

It should be noted here that this improved performance and simplified field weakening with reduced components and contactors is obtained at the cost of a more expensive split-field traction motor.

### 3. Use of Two Phase Freon Cooling of Power Semiconductors

Freon cooling of semiconductors is being extensively introduced in Japan. In addition to chopper cars, it is being used in substation rectifier equipment and on Shinkansen cars. The semiconductor elements are sealed in a tank and hence protected from environmental effects. Also, filters and blowers associated with forced air cooling are eliminated. This system, therefore, offers several advantages such as reduced size and weight of equipment, reduced noise levels, and improved reliability.



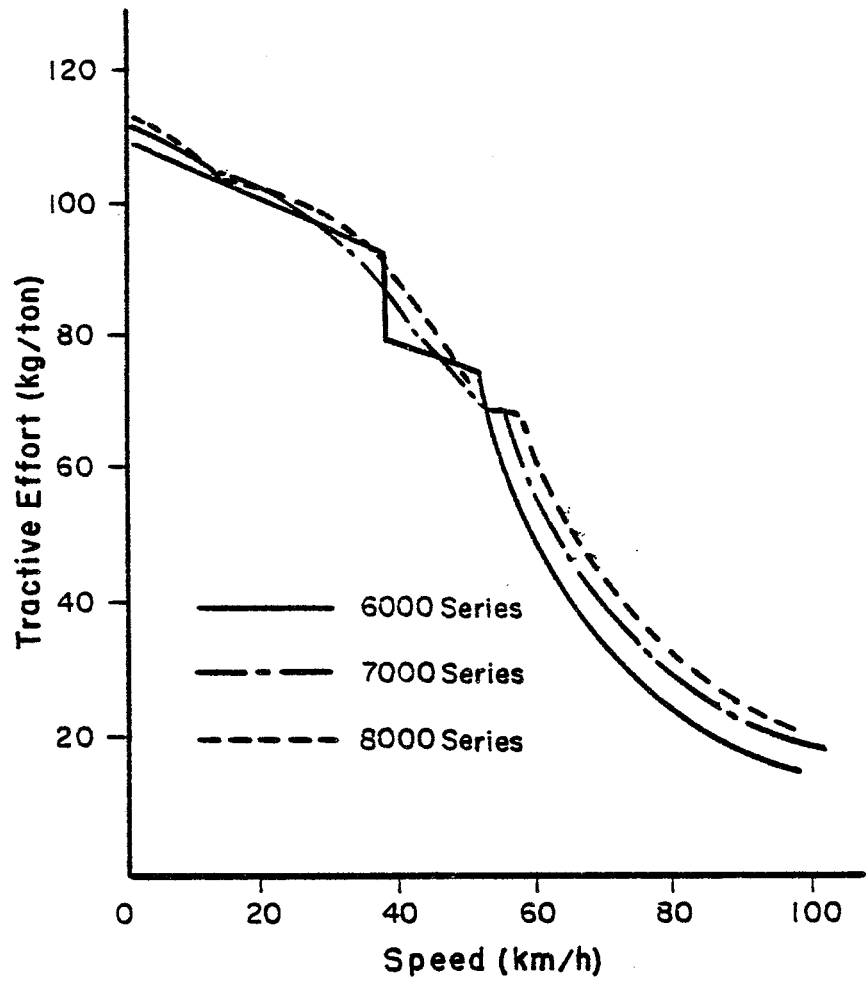

FIGURE 4. CAR PERFORMANCE IN POWERING

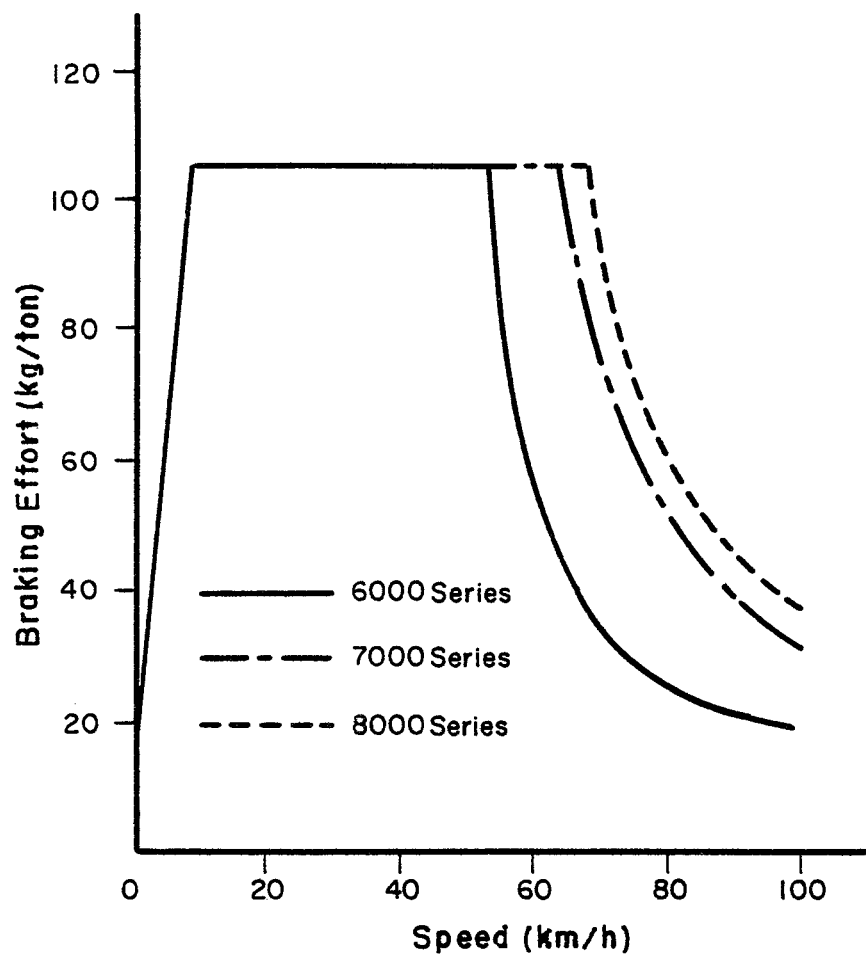

FIGURE 5. CAR PERFORMANCE IN BRAKING

Freon cooling of power semiconductor devices has almost become a standard design feature of chopper cars in Japan.

#### 4. Other Concepts

Microprocessors and fiber optics are being increasingly used onboard a car in ATC/ATO, diagnostics and lately even in propulsion equipment.

### 2.5 Maintenance of Chopper Equipment <sup>9</sup>

Rolling stock used in passenger transportation on subway, suburban and other lines goes through a lot of inspection and preventive maintenance to assure safe and reliable system operation. In fact, such inspection is mandated by the Japanese federal government according to the following schedule:

TABLE 2  
Maintenance and Inspection Schedule

Type of Inspection	Inspection Cycle	Content	Place of Inspection
48-hour Inspection	Within 48 hours or 1,600 km of travelling distance.	Inspect the main equipment of the train in the condition the equipment is installed on the train and the method of installation thereof.	Car depot
2-month Inspection	Within 60 days	Inspect all equipment of the train in the condition installed on the train and the method of installation thereof.	Car depot
2-year Overhaul (Inspection for the Important Part)	Within 2 years or 300,000 km of travelling distance.	Regarding all equipment of the train, disassemble the main parts and inspect the condition and functions thereof.	Workshop
4-year Overhaul (General Inspection)	Within 4 years	Regarding all equipment of the train, disassemble each part and inspect the condition and functions thereof.	Workshop

Under these legislated guidelines, inspection and maintenance of chopper control equipment is carried out as shown in Table 3.

TABLE 3  
Details of Chopper Inspection

Equip- ment name	Contents of Inspection		Type of Inspection				
			48 hours	1 month	Priority inspec- tion	General inspec- tion	
Reactor	Presence of external damage; Conditions of attachment to the body.		0	0	0	0	
	Damage to insulators, Presence of dirt and discoloration to insulators.		-	0	0	0	
	Disconnection of lead wires; Damage to wire covering.		-	-	0	0	
Condenser box	Presence of external damage; Confirma- tion of cover locking; Conditions of box attachment to the body.		0	0	0	0	
	Disconnection of lead wires; Presence of damage and dirt to wire covering.		-	0	0	0	
	Presence of deformation; oil leakage and dirt in condensers.		-	0	0	0	
Chopper Equipment	Boxes of chopper equipment	Presence of external damage; Confirmation of cover locking; Conditions of box attachment to the body.	0	0	0	0	
		Disconnection of lead wires, damage and dirt to wire cover- ing.	-	0	0	0	
	Thyristor diode stack	Presence of damage and dirt in thyristor diodes.		-	-	0	0
		Deterioration of thyristor diodes.		-	-	0	0
		Presence of damage and dirt in insulators.		-	-	0	0
		Presence of deformation, oil leakage and dirt in condensers.		-	-	0	0
		Disconnection, damage and de- formation of resistor.		-	-	0	0
		Conditions of attachment of leadwires and terminals.		-	-	0	0
Presence of neon glow lamps.		-	0	0	0		

TABLE 3 (continued)

Equip- ment name	Contents of Inspection		Type of Inspection			
			48 hours	1 month	Priority inspec- tion	General inspec- tion
Chopper Equipment	Reactor Resistor	State of attachment and lead wires.	-	-	0	0
		Deformation in saturable reactor anode balancer.	-	-	0	0
		Disconnection, damage and deformation of resistor.	-	-	0	0
	Gate Controller	State of attachment and lead wires.	-	0	0	0
		Presence of damage to card frame.	-	0	0	0
Wind pas- sage & air filter	Presence of dirt in the interior.	-	0	0	0	
	Suitability of characteristics* <sup>1</sup>	-	-	0	0	
Cooling blower fan	Presence of damage and dirt in wind passage including flexible wind passage.	-	-	0	0	
	Presence of damage and dirt in filters.	-	0	0	0	
	Presence of external damage and dirt.	-	0	0	0	
Simulated Tests <sup>2</sup>	Presence of damage and wear of bearings.	-	-	0	0	
	Strange noises emanating from the device.	0	0	0	0	
	Suitability of insulation resistance.	-	0	0	0	
	Suitability of insulation durability.	-	-	-	0	
	Suitability of operational sequence of powering and braking.	-	0	0	0	
Trial opera- tion	Suitability of protective operation sequence.	-	0	0	0	
	Suitability of the characteristics of gate controller.	-	0	0	0	
Trial opera- tion	Check of powering and braking current.	-	0	0	0	
	Check of acceleration and deceleration rates.	-	0	0	0	

- Notes:
1. Each card is tested separately for its input and output characteristics.
  2. Carried out by computerized diagnostic system.

These M & I requirements are based on the study of equipment failure data and are updated from time to time as necessary. Also, these are not based on classical analysis of cost/benefit ratio because safety in transportation is considered to be of paramount importance.

Use of computerized automatic diagnostics for car inspection is almost universal. The entire system is run like a typical computer center. The main computer is housed in an airconditioned enclosure and connecting multipin adapters are permanently wired and brought to the bay where a train is parked. The entire train is hooked onto the system via these adapters and the automatic inspection of the train is carried out within a short period of the order of about half an hour. A detailed test report is printed if necessary.

Service interruptions or extended service delays due to equipment failure is quite uncommon as a result of the above scheduled inspection and maintenance. For example, chopper cars on Chiyoda Line travelled 210 million kilometers and cars on Yurakucho Line travelled 45 million kilometers up to the end of September 1980. During this period, there were only a few instances of service interruption or operating delay of over ten minutes as shown below:

TABLE 4 Chopper Car Failures at TRTA

Car Series	1971	1972	1973	1974	1975	1976	1977	1978-1980*	Total Failures
6000 (Chiyoda)	4	1	2	0	2	3	1	0	13
7000 (Yurakucho)				1	3	0	0	0	4

\* up to end of September

Further, the above earlier failures on 6000 series cars were partly due to thyristors with lower (1300 V) voltage rating. Since 1974, however, choppers have been made with high voltage (2500 V) thyristors reducing this limited failure rate even further. Experience of other transit systems is similar.

### 3. DEVELOPMENT OF INVERTER CONTROLLED AC DRIVES

Inverter controlled induction motor drives have been under development in Japan for the past several years. The basic characteristics of such a drive were investigated by TRTA in 1978 by running a test car with ac propulsion.<sup>10</sup>

The power circuit of this drive is shown in Figure 6. Four induction traction motors were controlled by a single PWM inverter. The specifications for the motor and the inverter were:

#### Motor

Type	-	4 pole 3 phase squirrel cage induction motor
1 hour rating	-	130 kW, 1100 V, 2170 rpm, 75 Hz
Cooling	-	Self ventilated
Insulation	-	Class F
Mounting	-	Truck frame mount with parallel cardan drive.

#### Inverter

Input voltage	-	1500 V dc
Maximum output	-	1000 kVA
Output voltage	-	0-1100 V ac, 3 phase
Frequency	-	5-140 Hz

The maximum permissible wheel diameter difference was 11 mm (new wheel of 860 mm) to limit the load unbalance on the motors.

These tests demonstrated that all the requirements of a typical transit car propulsion system can be successfully met with such a drive. The high frequency components of the propulsion current were of magnitudes similar to those for chopper cars. The lower frequency (40-70 Hz) components were also sufficiently low to avoid interference in commercial frequency track circuits. Also, the noise induced in the ATC equipment was low, leaving a safety margin of over 20 dB.

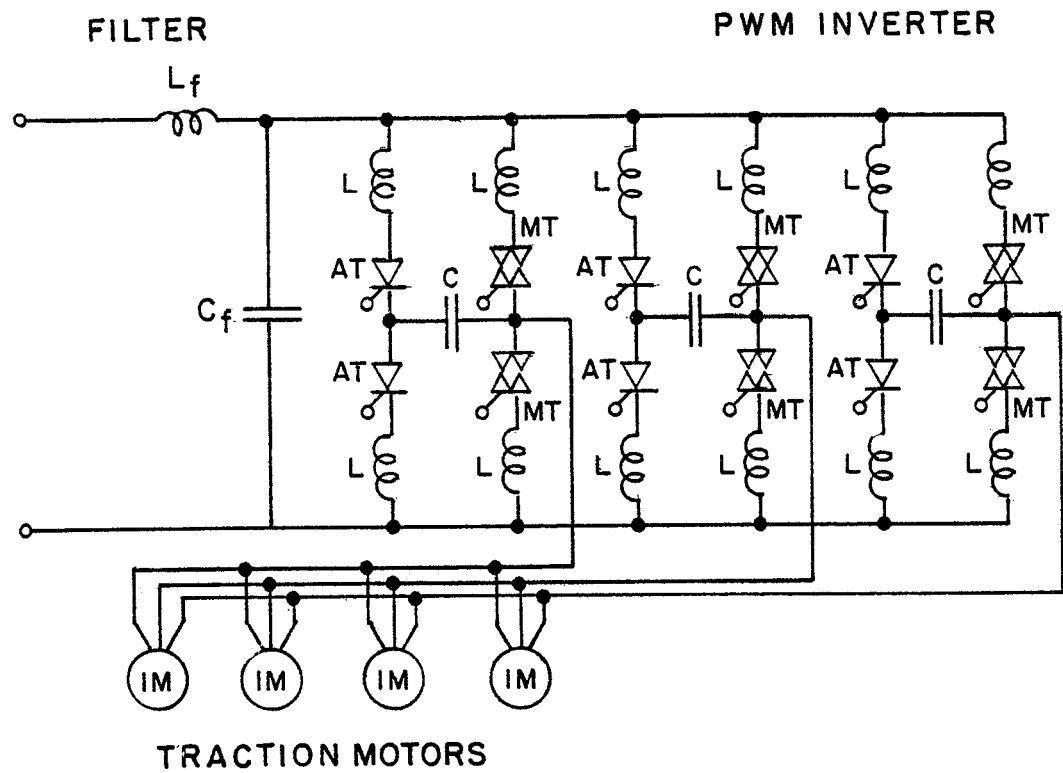

FIGURE 6. POWER CIRCUIT OF AC DRIVE



The next generation of ac drive is now under development by all the major Japanese propulsion manufacturers - Hitachi, Mitsubishi and Toshiba - for application at Osaka Subway. These drive systems will have the following advanced design features:

- o Use of reverse conducting or GTO thyristors,
- o microprocessor control, and
- o two phase freon cooling.

Prototypes of all the three drives will be tested at Osaka sometime this year.

Any decision regarding future deployment of these drives in Japan will be taken after completion of these trials.

#### 4. CONCLUSIONS

The Japanese companies and their client railroads and transit systems have undertaken and carried out clearly goal-oriented and very methodical research and development programs. Every new concept goes through a long series of prototype and pre-series tests before it is committed to production.

The railroads and the subways are very keen to introduce a broad range of advanced technologies across the board on their systems. The transportation industry is convinced that this is the only way to solve the problems currently plaguing the industry around the world.

## APPENDIX - A

### DETAILS OF SOME OPERATING TRANSIT SYSTEMS

#### A.1. SAPPORO SUBWAY

The necessity of a metro system for the city of Sapporo was realized as early as nearly twenty years ago. Initial planning studies were made in the early 1960's when the population was around a half million. Consequently some surface section was planned. The population was, however, rising very fast and hence the system when completed will have only a small surface section.

##### A.1.1 Operating Lines

The Nanboku line of the Sapporo subway (Figure A-1) was opened in December 1971. The line is 14.3 km long and runs north-south from Asabu to Makomanai. The section between Hiragishi and Makomanai is the surface section and the rest is in tunnel. It serves a total of 16 passenger stations with an average distance of 0.953 km between the stations. The tire gage is 2220 mm and the catenary voltage is 750 volts.

The Tozai line was opened in June 1976. It is 9.9 km long and runs east-west from Shiroishi to Kotoni. It serves a total of 11 passenger stations with an average distance of 0.99 km between them. The tire gage is 2150 mm and the catenary voltage is 1500 volts. An extension of the Tozai line for 7.4 km beyond Shiroishi to the east is currently under construction and is scheduled to open in March 1982.

##### A.1.2 Traffic Density

The traffic density on the Nanboku line is around 374,000 passengers per day. The rush hour headway is 4 minutes in the morning and 5 minutes in the evening. The offpeak headway is 7 minutes.

The traffic density on the Tozai line is around 215,000 passengers per day. The rush hour headway is same as above but the off peak headway is 6½ minutes.

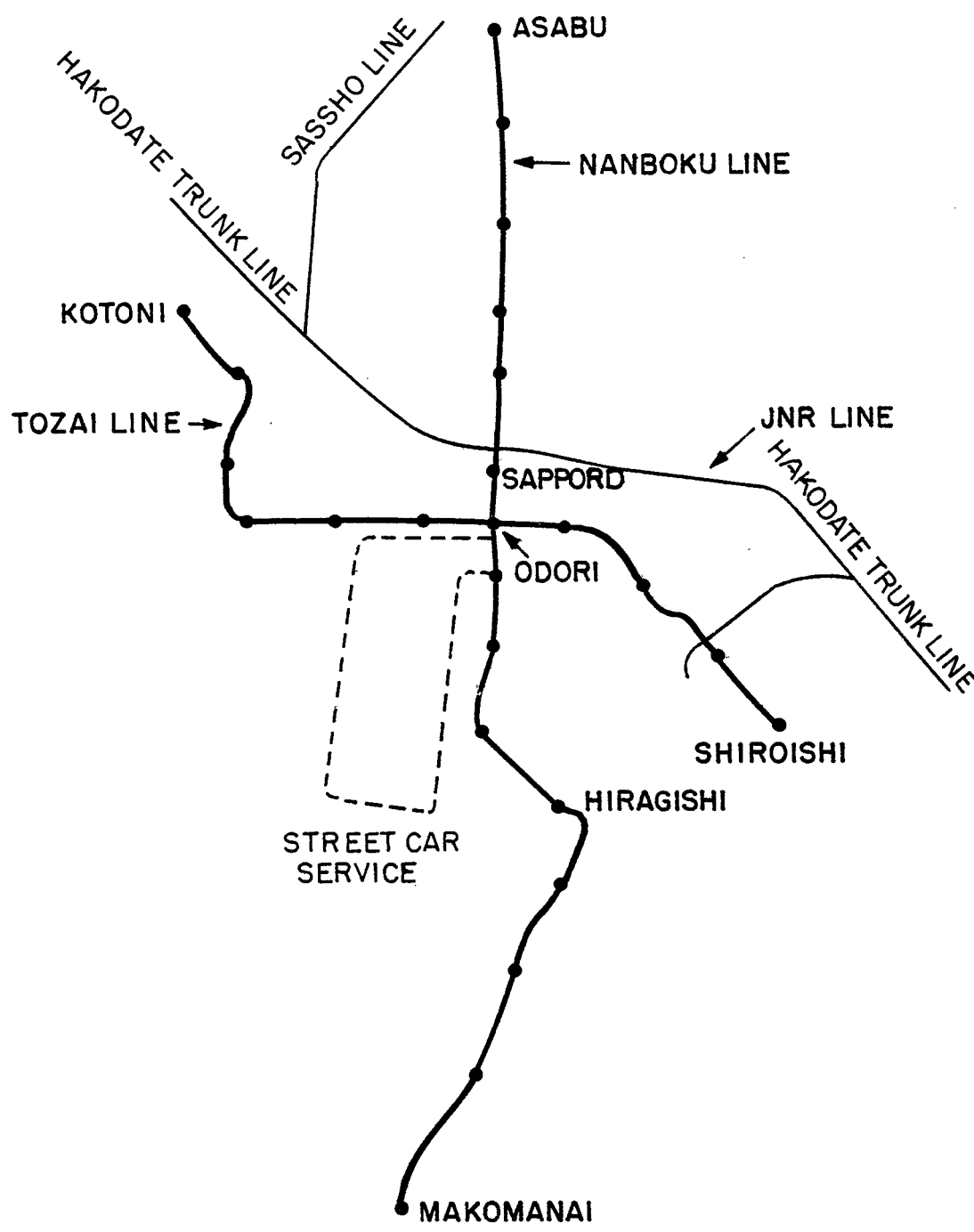

FIGURE A-1. SAPPORO SUBWAY NETWORK

### A.1.3 Rolling Stock <sup>11</sup>

The cars used on both these lines are rubber tired with a central guide rail. The cars ride on a concrete surface on the Nanboku line and on iron plates on concrete on the Tozai line. The train consist and the propulsion drive on the two lines are quite different as described below.

#### 3000-Series Cars on Nanboku Line

There are currently 160 cars (2000 series) with cam controllers on this line and 8 cars of 3000 series (one train) with chopper controller.

These cars are made of aluminum alloy and can carry a maximum of 2220 passengers in an 8-car consist. The average speed is 35 km/h and the maximum speed is 70 km/h. The rate of acceleration and deceleration is 4 km/h/s (approx. 2.5 m/h/s). DC series wound traction motors rated 110 kW (about 147.5 hp), 375 V, 327 A, 2230 rpm are used. A two phase chopper with each phase working at 200 Hz controls eight traction motors. There are two such chopper units on an 8-car train. The power thyristors are cooled using natural freon cooling.

#### 6000-Series Cars on Tozai Line (Figure A-2)

There are 80 cars of 6000 series with chopper controllers now operating on the Tozai Line and 64 new cars will be added by March 1982.

The cars run in a 2M2T consist and very soon they will run in a 3M3T consist. These cars are also made of aluminum alloy and carry a maximum of 1452 passengers in a 4-car train. Each wheel on a motor car is independently driven by a 70 kW (approx. 94 hp), 187.5 V, 430 A, 1900 rpm dc series wound traction motor. The acceleration rate of 3.5 km/h/s on these cars is smaller than the 3000 series cars. A two phase chopper unit with each phase operating at 200 Hz runs a total of 16 traction motors in two groups of 8 motors in series. When a car-pair is added, a single phase chopper will be used to drive the additional 8 motors.

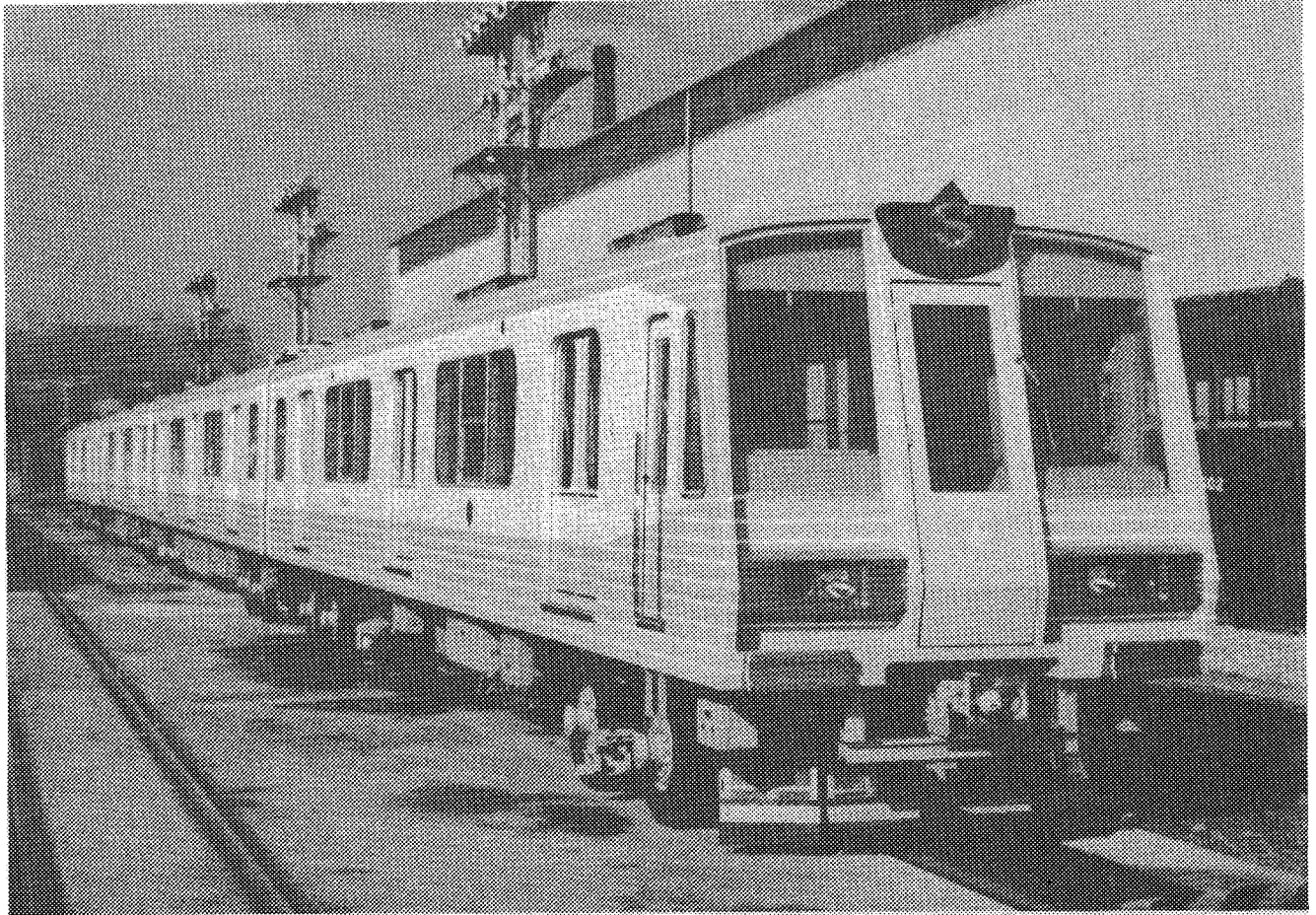

FIGURE A-2. 6000 SERIES CARS ON TOZAI LINE

The chopper equipment in the cars in operation uses forced air cooling of semiconductors but the new cars will use freon cooling.

The onboard ATO equipment in the existing cars uses microprocessor.

A.1.4 Energy Savings by Regeneration

The 2000 series cars with cam controllers on the Nanboku line have a specific energy consumption of 2.6 kWh per car-km. The 6000 series cars with chopper controllers on the Tozai line use 2.4 kWh per car-km. Taking into account the differences in the parameters of these two types of cars, it has been estimated that energy saving due to regeneration is about 23%.

A.1.5 Signalling System

Sapporo Metro is a rubber tired system and there are no running rails that can be used in train detection circuits as in wheel-on-rail systems. Hence a check-in/check-out system using one block separation is used for train control. But the frequencies and the code rates used on the two lines are different as described below.

(a) Nanboku Line: Two frequencies of 21.5 kHz and 23 kHz are used. The six code rates used are

<u>Speed</u> (km/h)	Abs.Stop	0	25	40	55	70
<u>Code rate</u> (Hz)	78	62	47	36	29	22

Maximum length of a block used is 300m.

(b) Tozai Line: Two frequencies of 2850Hz, 3450Hz are used for traffic in one direction and two other frequencies of 3150Hz. 3750 Hz are used for traffic in opposite direction. The six code rates used are

<u>Speed</u> (km/h)	Abs.Stop	0	25	40	55	70
<u>Code rate</u> (Hz)	37	32	28	22	17	13

Maximum length of a block used is 300m.

### A.1.6 Equipment Noise Levels

Noise levels were measured inside a car and on the platform for the three types of cars. In a car, noise was measured at the center of the car, at a height of 1.2 m from the floor. On the platform, noise was measured at the center of the platform, 4m away from the car side and at a height of 1.2m from the platform level when a train was running through the station. The noise levels were as follows in Table A-1.

TABLE A-1  
Equipment Noise Levels

<u>Car Type</u>	<u>Inside a Car</u>	<u>On the Platform</u>
2000	80 dB	84 dB Max.
3000	76-77 dB	80 dB Max.
6000	75 dB	82 dB Max.

### A.1.7 Electromagnetic Compatibility of Chopper Equipment

The location of the guide rail and the check-in check-out coils in relation to the chopper box and other propulsion hardware is shown in Figure A-3. Normally these coils and the chopper box are on the opposite sides of the guard rail but in some locations they are all on the same side of the guide rail. Hence, an aluminum shield is used as shown along the length of the chopper control box to avoid possible interference problems. The effectiveness of this shield has been computed to be about -13 db. With this shield in place, the signal-to-noise (S/N) ratio in the check-out coils is within a range of 21-34 whereas for the check-in coils S/N has been seen to be as low as 9 in some isolated cases.

The commutation circuit reactor is placed horizontally with its axis perpendicular to the length of the car. The line filter reactor and the motor



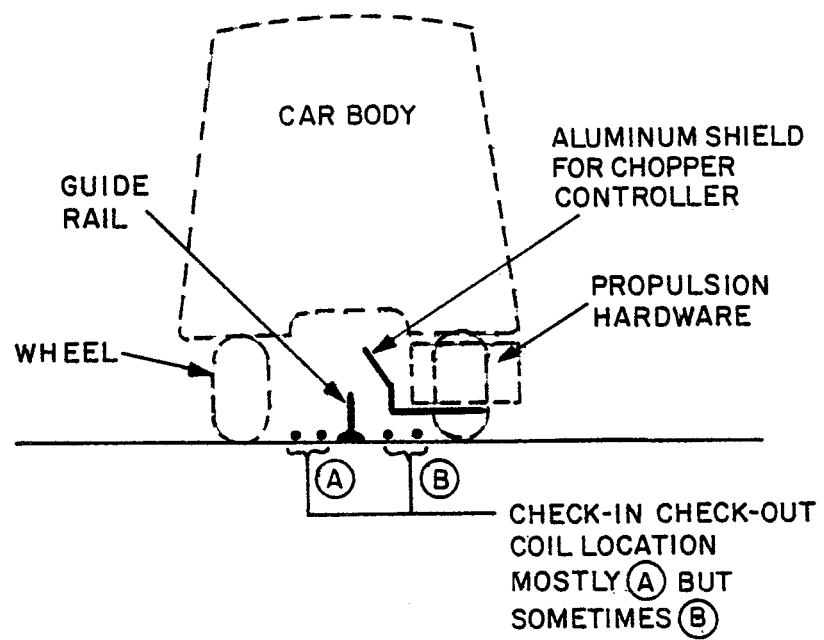

FIGURE A-3. LOCATION OF SYSTEM HARDWARE

reactor in the existing series 3000 cars are longitudinally placed. These will be placed with their axes in the transverse direction in the new cars.

#### A.1.8 Application of Advanced Design Features

Sapporo Metro is introducing advanced technology on a continuing basis. New chopper equipment will use freon cooling. Existing onboard ATO equipment on the Tozai Line uses microprocessor. Also, fiber optics will be introduced for data transmission on the Tozai Line extension. Sapporo tram cars are also expected to use chopper control within the next 3 years.

## A.2. TEITO RAPID TRANSIT AUTHORITY (TRTA), TOKYO

Tokyo, the capital city of Japan has a population of over 13 million in an area less than 2000 sq. km (about 770 sq. miles). The ever growing transit needs of this city are being increasingly met by similarly growing subway network. The TRTA itself was established in 1941 when it took over the operation of the then existing 14.3 km long Ginza Line. The construction of the Marunouchi Line was begun in 1951 and by 1970, three more lines - Hibiya, Tozai and Chiyoda - were added to the network. Presently TRTA operates a total of seven lines - Yurakucho and Hanzomon Lines in addition to the above five - covering 131.8 km. In addition, Tokyo is served by three lines (Toei Asakusa, Toei Mita and Toei Shinjuku) of Tokyo Metropolitan Transportation Bureau and Shin Tamagawa Line of Tokyu Railway. The TMTB lines cover 56.1 km and Tokyu Line covers a distance of 9.4 km.

Tokyo is thus served by a subway system with eleven lines covering 197.3 km. By 1985 this network is expected to grow to 13 lines covering 320 km. The total network carries about 5.5 million passengers per day of which TRTA system carries about 4.5 million passengers per day. Some of the characteristics of the TRTA lines are presented in Table A-2. Currently only three lines operate chopper cars and only these lines and their rolling stock will be considered further.

### A.2.1 Chiyoda Line

A limited section of this line was opened in 1969 and the entire line covering 24.0 km between Yoyogi Uehara and Abiko (Figure A-4) was completed in 1978. The scheduled speed on this line is 34 km/h with headways of 3 minutes in the morning, 6 minutes during the day and 5 minutes in the evening. Maximum permissible speed is 75 km/h. The line connects with the Joban Line of the JNR at one end and Odakyu Line at the other end.

The chopper cars of 6000 series (Figure A-5) operating on the Chiyoda Line also operate on the Joban and Odakyu Lines. These cars were first introduced in 1971 and they have following specifications:

TABLE A-2. Characteristics of TRTA Lines

Lines	Hibiya	Ginza	Marunouchi	Tozai	Chiyoda	Yurakucho	Hanzomon
Length, km	20.3	14.3	27.4	30.8	24.0	10.9	4.1
No. of Stations	21	18	27	21	20	12	4
Track Gage, mm	1076	1435	1435	1067	1067	1067	1067
Rail Weight kg/m	50	50	50	50	50	60	60
Maximum Grade, %	3.9	3.3	3.5	3.5	3.5	3.5	2.9
Traction Voltage, dc volts	1500	600	600	1500	1500	1500	1500
Power Collection	Trolley	3rd Rail	3rd Rail	Trolley	Trolley	Trolley	Trolley
Chopper Control	No	No	No	No	Yes	Yes	Yes
Passengers/day x 10 <sup>3</sup>	1015	967	1096	930	810	243	59
Car-km/day x 10 <sup>3</sup>	82	57	82	103	74	20	5.3
No. of Cars	304	241	330	361	266**	100	*

\*\* 210 with choppers

\* Rented cars from Tokyu

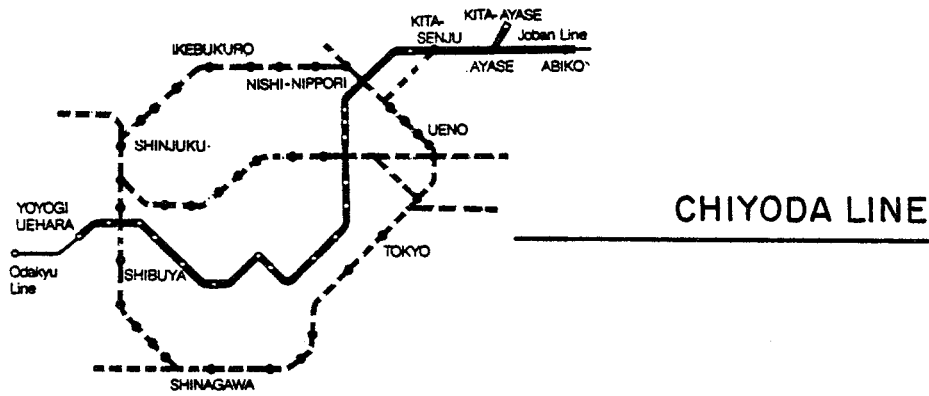

**YURAKUCHO LINE**

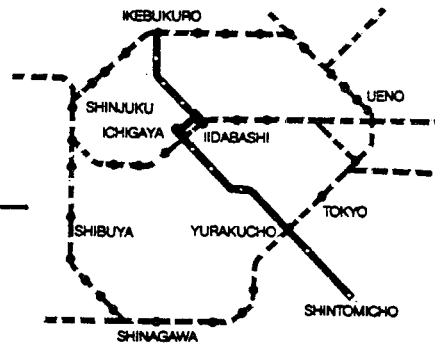

**HANZOMON LINE**

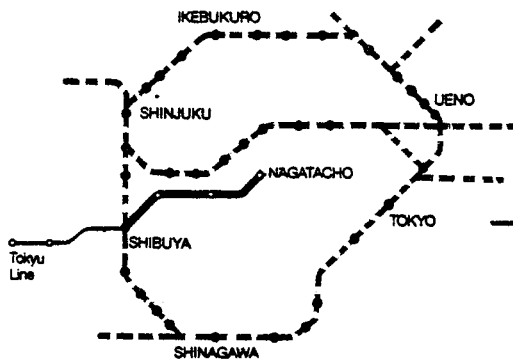

**FIGURE A-4. TRTA LINES WITH CHOPPER CARS**



FIGURE A-5. 6000 SERIES CARS FOR CHIYODA LINE

- o Traction motor: Series wound, 145 kW, 375 V, 425 A, 2300 rpm  
Max. 5300 rpm, Class F
- o Chopper: 2 phase\*, 330 Hz (each). Forced air cooling.  
One such unit for each pair of motored cars  
controlling 8 traction motors.
- o Train consist: 2T2M2T4M
- o Passengers/train: 1424
- o Maximum speed: 100 km/h, although Chiyoda Line restricts it  
to 75 km/h, these cars have to go on JNR and  
Odakyu lines.
- o Acceleration: 3.3 km/h/s
- o Deceleration: 3.7 km/h/s

#### A.2.2 Yurakucho Line

A major section of this line opened in 1974 and the entire line covering 10.9 km between Ikebukuro and Shintomicho (Figure A-4) is now in operation. This line will connect with two private suburban railways at both ends after the construction in the connecting area is completed. The maximum speed is 75 km/h and the headways are the same as on the Chiyoda line.

The chopper cars of 7000 series (Figure A-6) operate on this line and have the following specifications:

- o Traction motor: 150 kW, 375V, 440A, 2100 rpm, Max. 5300 rpm,  
Class F Series wound with split field for AVF  
Control.

---

\* Initially a 3 phase unit was used.



FIGURE A-6. 7000 SERIES CARS FOR YURAKUCHO LINE



FIGURE A-7. 8000 SERIES CARS FOR HANZOMON LINE



- o Chopper: 2 phase, 330 Hz (each phase) Forced air cooling. One such unit for each pair of motored cars controlling 8 traction motors. AVF Control.
- o Train consist: 1T4M. (now)  
2T2M2T4M (in future)
- o Passengers/train: 704 (now), 1424 (in future)
- o Maximum speed: 100 km/h for future operation on private railway lines
- o Acceleration: 3.3 km/h/s
- o Deceleration: 3.5 km/h/s

### A.2.3 Hanzomon Line

This line covering 4.1 km between Shibuya and Nagatacho (Figure A-4) opened in 1978 and connects to the Tokyu Line between Shibuya and Nagatsuda. The maximum speed on this line is 75 km/h and the headways for morning, daytime and evening service are 4 min., 7.5 min. and 5 min. respectively.

Currently series 8000 cars (Figure A-7) with field chopper control of Tokyu Railway have been leased by TRTA for operation on this line. Another 46 cars of Series 8000 with armature chopper control will be introduced in service on this line soon and these will be owned by the TRTA.

These TRTA cars have the following specifications:

- o Traction motor: 160 kW, 375 V, 470A, 1800 rpm, Max. 4650 rpm, Class H, Series wound with split field for AVF control
- o Chopper: 2 phase, 330Hz (per phase), Freon cooled, one such unit controls 8 motors on two cars.

- Train consist: T6MT (now); T4M2T2MT (in future)
- Passengers/train: 1136 (now), 1424 (in future)
- Maximum speed: 100 km/h for service on Tokyu Line
- Acceleration : 3.3 km/h/s
- Deceleration: 3.5 km/h/s

#### A.2.4 Energy Savings by Regeneration 1, 9, 12

The chopper cars in operation at TRTA travel 7000 - 10000 kms per month and over the last ten years TRTA has a total revenue service experience of more than 250 million car-kms with chopper cars.

The energy consumption of 6000 series chopper cars was compared with that of 5000 series cam controlled cars on the Chiyoda Line.

The mean value of daily energy consumption of these cars is:

6000 Series = 1.62 kWh/Car-km (propulsion)  
 +0.25 kWh/Car-km (auxiliary)

5000 Series = 2.94 kWh/Car-km (propulsion)  
 +0.24 kWh/Car-km (auxiliary)

The 6000 series cars, therefore, use 41% less energy than the 5000 series cars. Considering the difference in weight of these cars and the train consist, it has been estimated that use of regenerative braking has resulted in energy savings of about 34 percent.

#### A.2.5 Signalling System

TRTA uses double insulated rail track circuits for train detection and cab signalling on the three lines with chopper equipment. In addition to the 50 Hz used in station area and crossovers, the following frequencies are used:

2850  $\pm$  85 Hz, 3450  $\pm$  85 Hz for traffic in one direction.  
 and 3150  $\pm$  85 Hz, 3750  $\pm$  85 Hz for traffic in opposite direction.

The code rates used are

<u>Speed</u> (km/h)	0	25	40	55	75
<u>Code Rate</u> (Hz)	64	42	35	28	23

The minimum current at the receiving end is 140 mA and the maximum block length is 500 meters.

Other TRTA lines use 2300 Hz, 3100 Hz for one track and 2700 Hz and 3500 Hz for the other track. Six code rates of 10, 15, 25, 35, 63 and 85 Hz are used to control the wayside signals.

#### A.2.6 Electromagnetic Compatibility of Chopper Equipment

There is no identifiable commutating reactor in these chopper cars. The commutation circuit has a capacitance of 30  $\mu$ F and an inductance of 13  $\mu$ H for 6000 and 7000 series cars and an inductance of 16  $\mu$ H for 8000 series cars. Further, twisted cables in steel covers are used in commutation circuit (refer to Figure 3). The chopper controllers are placed in steel boxes with aluminum cover plates in 6000 and 7000 series cars.

These cars travel on JNR lines with dc and power frequency track circuits with frequencies of 25, 30, 50, 60, 83 1/3, 100 and 120 Hz. The rectifier substations of the JNR also carry harmonic filters for harmonic orders of 6, 12, and 18. The chopper cars have no EMC problems in service on these and other private railway lines.

#### A.2.7 Application of Advanced Design Features

All the future chopper equipment for TRTA will use freon cooling of semiconductors. Microprocessors are currently in use as monitoring devices for chopper, brake and onboard ATC equipment on 8000 series cars. There are

now plans to use fiber optics for data transmission between the central and the wayside data systems as well as for transmitting the thyristor gate signals in chopper circuits.

### A.3 NAGOYA SUBWAY

A small section covering 2.6 km between Sakae and Nagoya of Line 1 was inaugurated in 1957. Since then three more lines have been added to cover a total distance of 51.5 km. Several more lines are now under construction and few more are planned for future construction as shown in Figure A-8.

#### A.3.1 Operating Lines

Line 1 covers a distance of 17.5 km from Nakamura to Fujigaoka. It goes through the Nagoya station of the JNR where the terminals of Kinki Nippon Railway and Nagoya Railroad are concentrated. The line also goes through Sakae, the downtown area.

Line 2 was added in 1965 and runs north-south from Ohzone to Nagoyako (Nagoya Port) and crosses Line 1 at Sakae. This line covers a distance of 14.9 km.

Line 4 started revenue service in 1971 and is a branch line from Line 2 from Kanayama to Aratamabashi. This line will be extended to form a loop as shown in the map. Currently, it is only 5.7 km long.

Line 3 was added in 1977 and runs a distance of 13.4 km from Fushimi on Line 1 to Akaike, crossing Line 2 at Kamimaezu.

Line 3 is supplied by a 1500 V dc catenary and the other three lines have a 600 V dc third rail supply. Also, Line 3 has a gage of 1067mm and the other lines have a gage of 1435 mm.

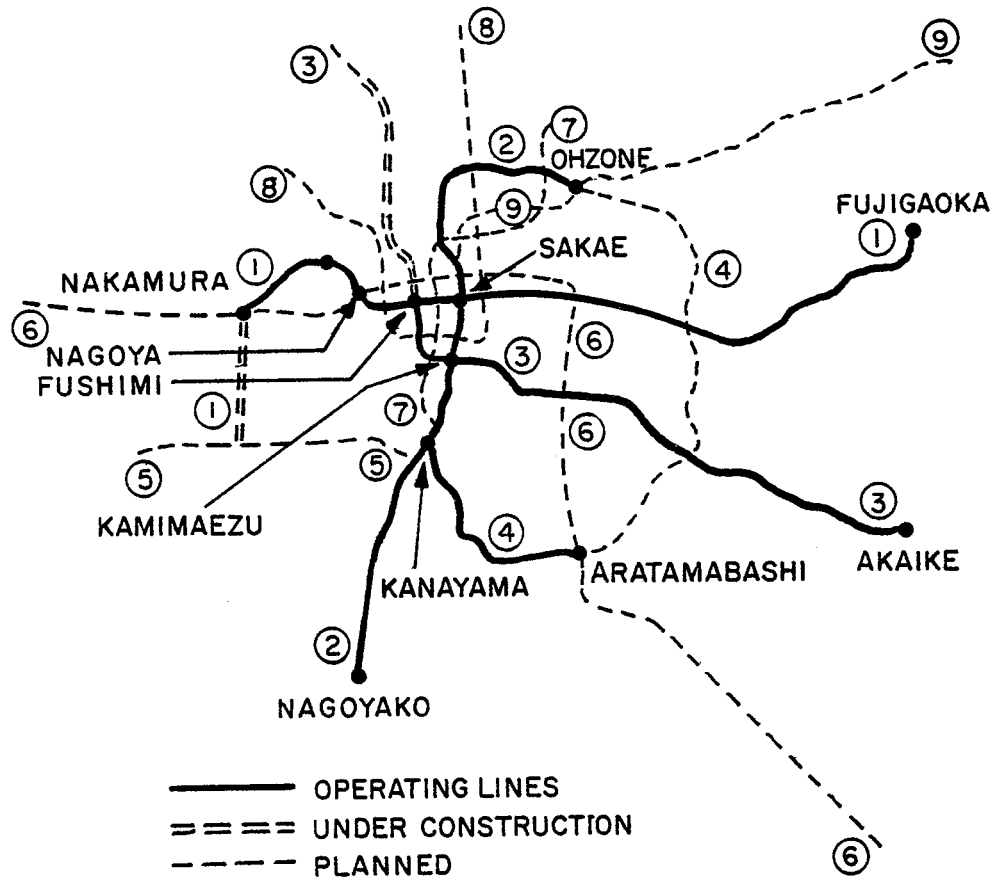

FIGURE A-8. PLANNED NETWORK FOR NAGOYA SUBWAY

### A.3.2 Traffic Density

The train consist and the headways on these lines are given below:

TABLE A-3. Train Headways at Nagoya

Line	Cars/Train	Headway, min.		
		Morning	Day	Evening
1	6	2	4	3
2	5	3	4	3
3	4	5	7	5
4	5	6	8	6

Traffic density on these lines is probably around one million passengers per day.

### A.3.3 Rolling Stock

Lines 1, 2, and 4 currently run cam controlled cars although one chopper controlled train (T4MT) has been introduced on Line 1 last year. These chopper cars of series 5000 (Figure 15) will be the future standard cars on Line 1.

Chopper controlled propulsion system was first introduced in 1977 on the newly opened Line 3. Now a total of 52 cars of this 3000 series (Figure 16) are in revenue service on this line. Since this is extended into the suburban lines of Nagoya railroad, these cars, the track gage, catenary system are designed to be compatible with Nagoya Railroad.

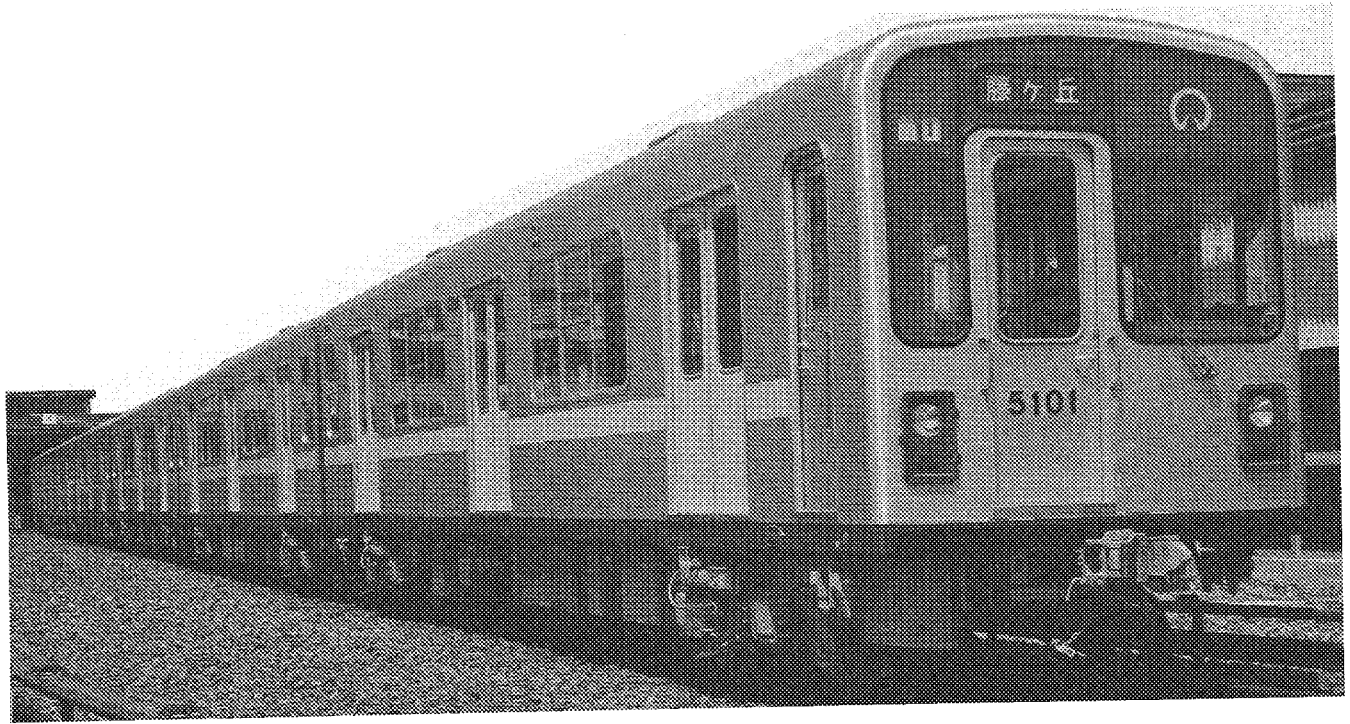

FIGURE A-9. 5000 SERIES CARS FOR LINE 1



FIGURE A-10. 3000 SERIES CARS FOR LINE 3



The chopper systems of these two cars are basically different as described in Table A-4 below <sup>13</sup>:

TABLE A-4. Characteristics of Chopper Cars

	<u>Line 1</u> <u>5000 Series</u>	<u>Line 3</u> <u>3000 Series</u>
Traction Motor	95 kW, 300 V 360 A, 2000 rpm Max. 4100 rpm, Class H	135 kW, 375 V, 395 A 1960 rpm, Class F
Motor Connection	2S 4P for a car pair.	4S 2P for a car pair. 8S1P for AVF fields.
Chopper	2 phase, 200 Hz each phase Freon cooling one unit per car pair Constant weak field control	2 phase, 243 Hz each phase Forced air cooling one unit per car pair. AVF Control
Train Consist	T4MT Aluminum alloy cars	4M (now) 4M2T2M (in future) Stainless steel cars
Passengers/train	680	540 (for 4M)
Maximum speed, km/h	65	100
Acceleration, km/h/s	3.3	3.0
Deceleration, km/h/s	4.0, Emergency 4.5	3.5, Emergency 4.0

In series 3000 cars, the chopper is shorted out at high speeds.

#### A.3.4 Energy Savings by Regeneration<sup>13</sup>

The 3000 series cars run more than 9000 km per month on Line 3 and have a specific energy consumption of about 1.82 kWh/Car-km whereas the series 5000 cars run about 6200 km per month and have a specific energy consumption of 1.15 kWh/Car-km. It should be remembered that the average weight of a car in the consist on Line 1 is 23.47 tons and on Line 3 it is 37.85 tons. It has been estimated that about 30% of the energy consumed by the cars during propulsion is returned during regenerative braking.

#### A.3.5 Signalling System

Single rail insulated and double rail insulated type 60 Hz track circuits are used on Line 1 and mechanical type of devices are used for train protection. The wayside signals at most locations have 3 aspects but up to 5 aspects are found at some locations.

Line 3 uses audio frequency circuits with continuously welded rails. The speed commands are transmitted by coding the basic frequencies of 17 kHz, 20 kHz for traffic in one direction and of 18 kHz, 21 kHz for traffic in the opposite direction. The code rates used are:

<u>Speed</u> (km/h)	75	55	40	25	0	S	X
<u>Code rate</u> (Hz)	16	23	28	42	72	54	64

Train detection signal is coded at 144 Hz. The minimum current at the receiving end is 50 mA and the maximum block length is 350 m.

Lines 2 and 4 use a continuous signal of different frequencies to transmit the speed commands. The frequencies used are given in Table A-5. The minimum signal at the receiving end is 106 mA and the maximum block length is 300 m.

TABLE A-5

## Signalling Frequencies For Lines 2 And 4 At Nagoya

Traffic Direction	Train Detection Frequency Hz	Frequency used for speeds(km/h), Hz					S
		65	40	20	0		
1	17140	16845	17070	16925	17000	17205	
2	19860	20155	19930	20075	20000	19795	

A.3.6 Electromagnetic Compatibility of Chopper Cars <sup>14-17</sup>

Nagoya subway conducted several theoretical and experimental investigations regarding EMC of the chopper cars with signalling system.

Since the 3000 series cars will be running on private railway lines, electromagnetic interference characteristics of the (brushless) BLMG set was independently investigated. It was concluded that under worst operating conditions, the high frequency components (17-21 kHz) in the rail return current when BLMG is started could pose some problems if the train detection signal was not modulated. But with 144 Hz modulation of the train detection signal, sufficient signal-to-noise ratio is obtained even under the worst scenario.

The low frequency components of current are, however, quite high. For example, during starting of the BLMG, 60 Hz component was measured to be as high as 3.8 amperes although currents larger than 2 amperes lasted only for one second. But these levels of 60 Hz component, together with other low frequency components could cause potential malfunction in 60 Hz track circuits. Hence, a 2-second delay was added in these track circuits to avoid any possible interference.

### Conducted Noise

The harmonic components of currents in the third rail were measured for 1000 series (cam controlled) and 5000 series (chopper controlled) cars.

The input filter on the chopper cars for a chopper unit is an LC filter with  $L = 2\text{mH}$  and  $C = 7500 \mu\text{F}$  thus giving a resonance frequency of 41.1 Hz. The chopper frequency is 400 Hz (200 Hz x 2 phases) and the current per train is 2260 amperes. The current components were measured as follows:

### Chopper harmonics

Frequency, Hz	400	800	1200	1600	2000
Max. Current, A	10.74	1.34	0.4	0.168	0.086

### Substation harmonics

Frequency, Hz	360	720	1080	1440	1800
Max. Current, A	10.42	1.32	0.38	0.164	0.082

For 1000 series cars with cam controllers, only substation harmonics were measured as:

Frequency, Hz	360	720	1080	1440	1800
Max. Current, A	25.8	3.18	0.96	0.396	0.198

It must be remembered that there is no filter on cam controlled cars and the impedance presented by a car to substation harmonic voltages depends on the traction motor characteristics.

The input filter on the 3000 series cars is an LC filter with  $L = 5$  mH and  $C = 3200$  F and the chopper frequency is 486 Hz (243 Hz x 2 phases). For a current of 1100 amperes per train in propulsion, the harmonic components were measured as:

Chopper harmonics

Frequency, Hz	486	972	1458	1944	2430
Max. Current, A	2.34	0.28	0.092	0.031	0.012

Substation harmonics

Frequency, Hz	360	720	1080	1440	1800	2160	2520
Max. Current, A	8.83	1.18	0.67	0.52	0.25	0.197	0.15

Although the chopper is a two phase unit, the fundamental chopper frequency of 243 Hz is really not cancelled out because of inherent unbalance. A maximum component of 1.1 ampere was measured at 243 Hz. This is more than 45 percent of the 486 Hz component of 2.34 amperes. Similarly, although the substation has a 6 pulse rectifier circuit it still has components with frequencies of 60 Hz, 120 Hz, and 240 Hz with maximum values of about 2%, 20% and 30% of the 360 Hz component. All these components are due to inherent unbalance in the three phase input voltages. These values are given to suggest only an order of magnitude for these components and no general conclusions should be drawn from this data.

### Induced Noise for 3000 Series Cars

Earlier in main section 2.3.2 it was stated that EM noise induced in the receiving coil of audio frequency overlay (AFO) circuits was one of the most significant EMC problems experienced in Japan. The EM compatibility of this car with AFO circuits was, therefore, investigated for the nominal carrier frequencies of 3, 3.5, 4, 5, 6, 7.6, 10.9 kHz. The chopper equipment was observed to cause malfunction of the AFO receiver for frequencies of 3, 3.5, and 4 kHz for some specific attenuator settings.

These EMI problems were subsequently eliminated by introducing the following countermeasures:

- o Use of twisted cables for connections to the condenser box and the commutating condenser,
- o Use of improved packaging within the chopper box to reduce flux emissions, and
- o Use of only higher carrier frequencies for the AFO circuits.

#### A.3.7 Application of Advanced Design Features

The chopper equipment used in Nagoya uses advanced design features such as use of reverse conducting thyristors, AVF control and freon cooling.

#### A.4. OSAKA SUBWAY

Osaka municipality started a street car service between Osaka Port and Hanazonobashi as early as 1903. Later a small section of Midosuji Line (Line 1) between Umeda and Shinsaibashi of subway was opened in 1933. Later even a trolley bus service was initiated, although by 1970 the streetcar and the trolley bus services were discontinued. Currently the six lines of the subway extend over 86.1 km (see Figure A-11) and carry over 2 million passengers per day - more than 5 times the passengers carried by the municipal bus service.

##### A.4.1 Operating Lines

The Midosuji Line - Line 1, 19.5 km long runs from Esaka to Abiko and will be extended further to Nakamozu. It serves a total of 17 passenger stations. The minimum headway for the central section between Nakatsu and Tennoji is 2 minutes in the morning, 4 minutes in the afternoon and 2½ minutes in the evening. A total of 264 cars run on this line in an eight car consist of 4MT2MT. The service is extended 3 stations beyond Esaka to Senrichuo on the Kyuko line of a private railway - Kita Osaka Railway.

The Tanimachi Line - Line 2 covers a distance of 26.3 km between Moriguchi and Yao Minami, serving 25 passenger stations. This line is being extended beyond Moriguchi to Dainichi. The minimum headway on the central sections of this line is 3 minutes in the morning, 6 minutes in the afternoon and 3½ minutes in the evening. A total of 210 cars run with a 6-car consist of 4M2T or 6M depending on the series.

The Yotsubashi Line - Line 3, 11.4 km long, runs between Nishi Umeda and Suminoekoen. It serves 11 passenger stations with a headway of 2 3/4 minutes in the morning, 5-6 minutes in the afternoon and 3½ minutes in the evening. A total of 20 trains with a 4M1T consist run on this line. The much publicized New Tram System using rubber tired cars operates beyond Suminoekoen to Nakafuto and serves the ferry terminal.

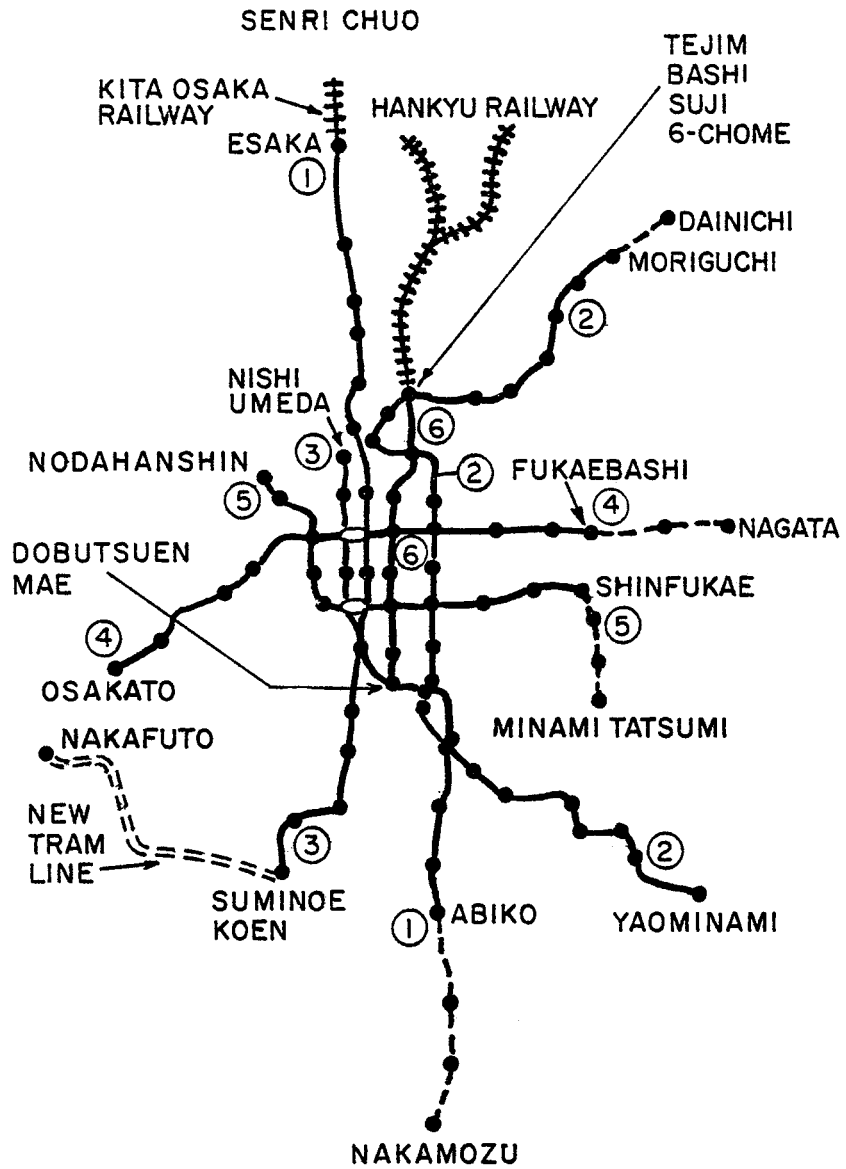

FIGURE A-11. OPERATING LINES OF OSAKA SUBWAY





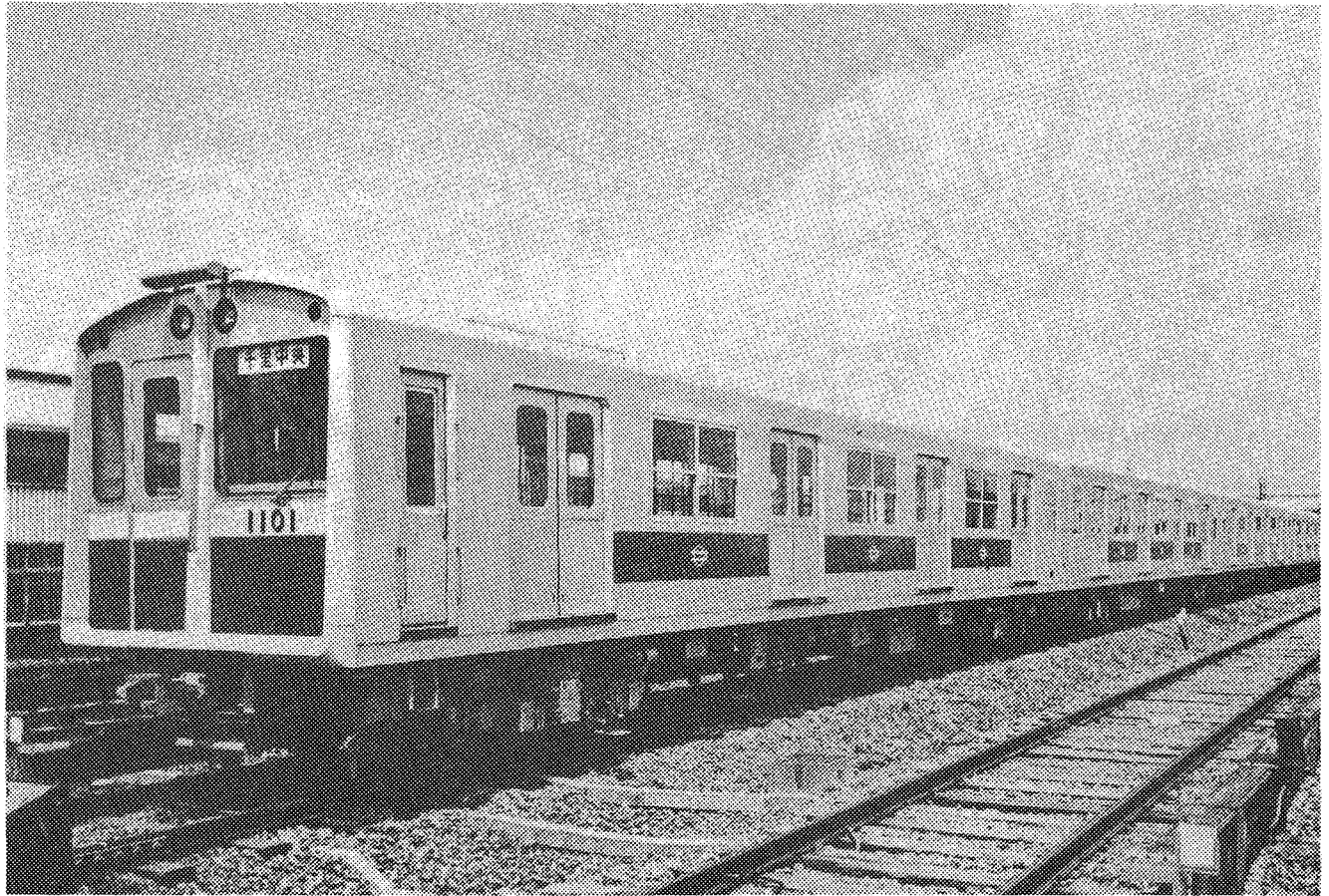

FIGURE A-12. 10 SERIES CARS FOR LINE 1

- o Train Consist            4M 1T 2M 1T
- o Passengers/train        1060
- o Maximum speed          70 km/h
- o Acceleration            3.0 km/h/s
- o Deceleration            3.5 km/h/s

Cars use regenerative braking to reduce energy consumption as well as heat load on the tunnel. The new wheel has a diameter of 860 mm. On the motor cars, the wheel diameters are maintained within 1mm on the same axle, 6mm on the same truck and 11 mm on the same car. For a trailer car these numbers are 3 mm, 10 mm, and 20 mm respectively. The wheels are condemned at 780 mm.

#### A.4.3 Signalling System

Commercial frequency (60 Hz) circuits using one or two insulated rails as well as audio frequency circuits using continuously welded rails are used on Osaka subway. Three frequencies of 10 kHz, 12.5 kHz, and 15.5 kHz are used as signalling frequencies. The ATC systems on the lines are, however, different as follows:

##### Lines 1-4

The audio frequency signal is coded to get a 5 aspect wayside signalling system. The code rates are

<u>Signal, color</u>	G	YG	Y	YY	R
<u>Code rate, Hz</u>	22	36	47	78	135

##### Line 5

This line has cab signalling with the following code rates:

<u>Speed, km/h</u>	70	60*	50	40	25	15	0	Stop
<u>Code rate, Hz</u>	22	29*	36	47	78	100	135	CW

---

\*Spare.

## Line 6

A 5 aspect wayside signalling system is based on the following code rates:

<u>Signal, color</u>	G	YG	Y	YY	R
<u>Code rate, Hz</u>	15	20	32	40	80

The minimum signal level is 70 mA, although nominally a current of 120-180 mA is present.

### A.4.4 Electromagnetic Compatibility of Chopper Cars

Each chopper unit has a filter with a resonance frequency of 39.2 Hz ( $L = 2.5$  mH and  $C = 6600$   $\mu$ F) and harmonic components at high frequencies are effectively attenuated giving a worst case signal-to-noise ratio of 37 dB with 100 per cent rail unbalance and about 41 dB with normal rail unbalance. These levels are measured at the input to the power amplifier driving the relays.

The induced noise from the magnetic flux under a car, however, was sufficient to reduce S/N ratio below an unacceptable level. With prototype cars, although track relays did not malfunction, the induced noise resulted in an insufficient S/N margin in 135 Hz code rate circuits. In mass produced cars, the chopper design was altered as follows:

1. Frequency was raised to 200 Hz and the commutating condenser value was reduced from 85  $\mu$ F to 60  $\mu$ F.
2. Twisted cables were used in chopper circuit (see Figure 3)
3. The chopper box was provided with Aluminum covers to provide some shielding.

With these changes there is enough margin (20 dB) in the S/N ratio for audio frequency circuits.

For commercial frequency (60 Hz) circuits, however, a 2-second delay has been introduced in the relay circuits to avoid any malfunction.

#### A.4.5 Application of Advanced Technology

Freon cooled chopper equipment is currently operating in revenue service on the Midosuji Line. This year ac drive equipment using induction motors will be tested on Chuo Line - Line 4 of Osaka Metro. This type of equipment is being manufactured by all the three major companies - Hitachi, Mitsubishi, and Toshiba - and will use advanced design features such as

- o GTO or Reverse Conducting Thyristors
- o  $\mu$ P control of PWM inverter
- o Freon Cooling

## A.5. KOBE SUBWAY

Although initial planning for Kobe subway began as early as 1968, the first line opened for service in early 1977. A second line is under construction now and is scheduled to be completed in 1984. After completion of this line, the subway will provide an access to all the railway lines serving Kobe - Shinkansen, JNR, Kobe Electric Railway, Kobe Kosoku Railway, Hanshin Railway, Hankyu Railway and Sanyo Railway. It will also be connected to the much publicised Kobe New Transit System - recently opened DPM system for Kobe.

### A.5.1 Operating Line

The Seishin Line of Kobe subway is the only line in operation today. It covers a distance of 5.7 km between Myodani and Shinnagata. It serves four passenger stations (see Figure A-13) with a headway of 7½ minutes in the morning, 15 minutes in the afternoon and 10 minutes in the evening. The line is supplied at 1500 V dc by overhead wire with primary power being supplied by Kansai Electric Power Company.

### A.5.2 Rolling Stock

1000 series chopper controlled cars shown in Figure A-14 are made of aluminum alloy and operate on this line in a 4M consist. After the second line-Yamate Line - opens, a 6-car train will be operated in a 4M 2T consist.

These cars have the following characteristics:

- o Traction motor            130 kW, 375 V, 385 A  
                                 2050 rpm dc series split  
                                 field motor (AVF control)  
                                 max. 4230 rpm, Class F
  
- o Chopper                    2 phase, 175 Hz per phase,  
                                 Forced air cooled, one unit controlling  
                                 8 motors on 2 cars. AVF Control.

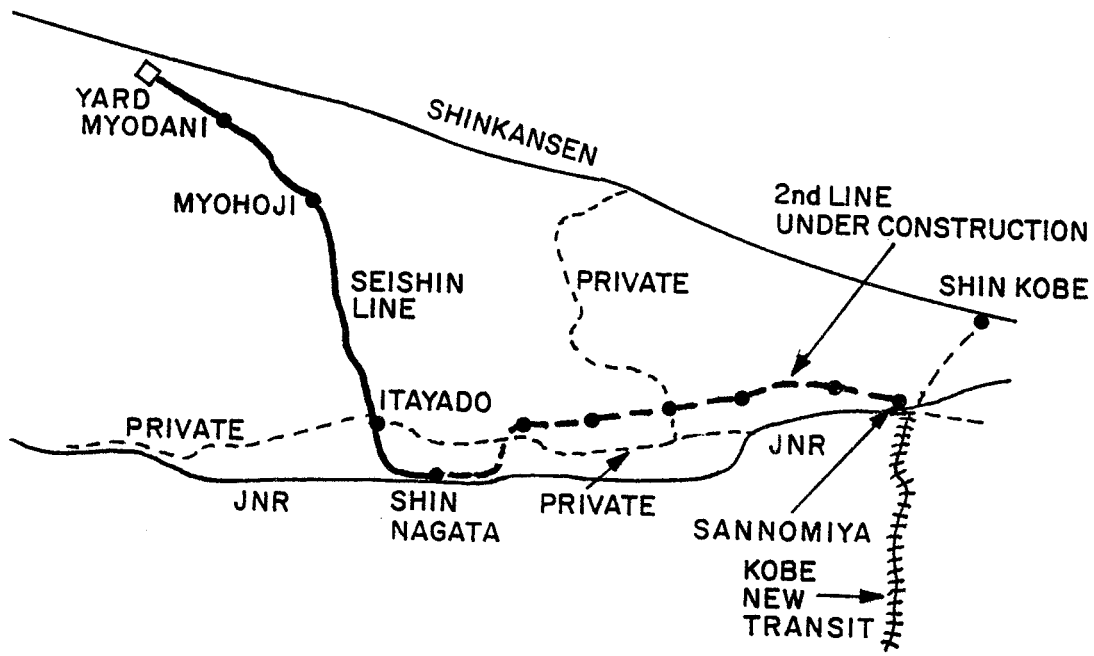

FIGURE A-13. PLANNED NETWORK FOR KOBE SUBWAY

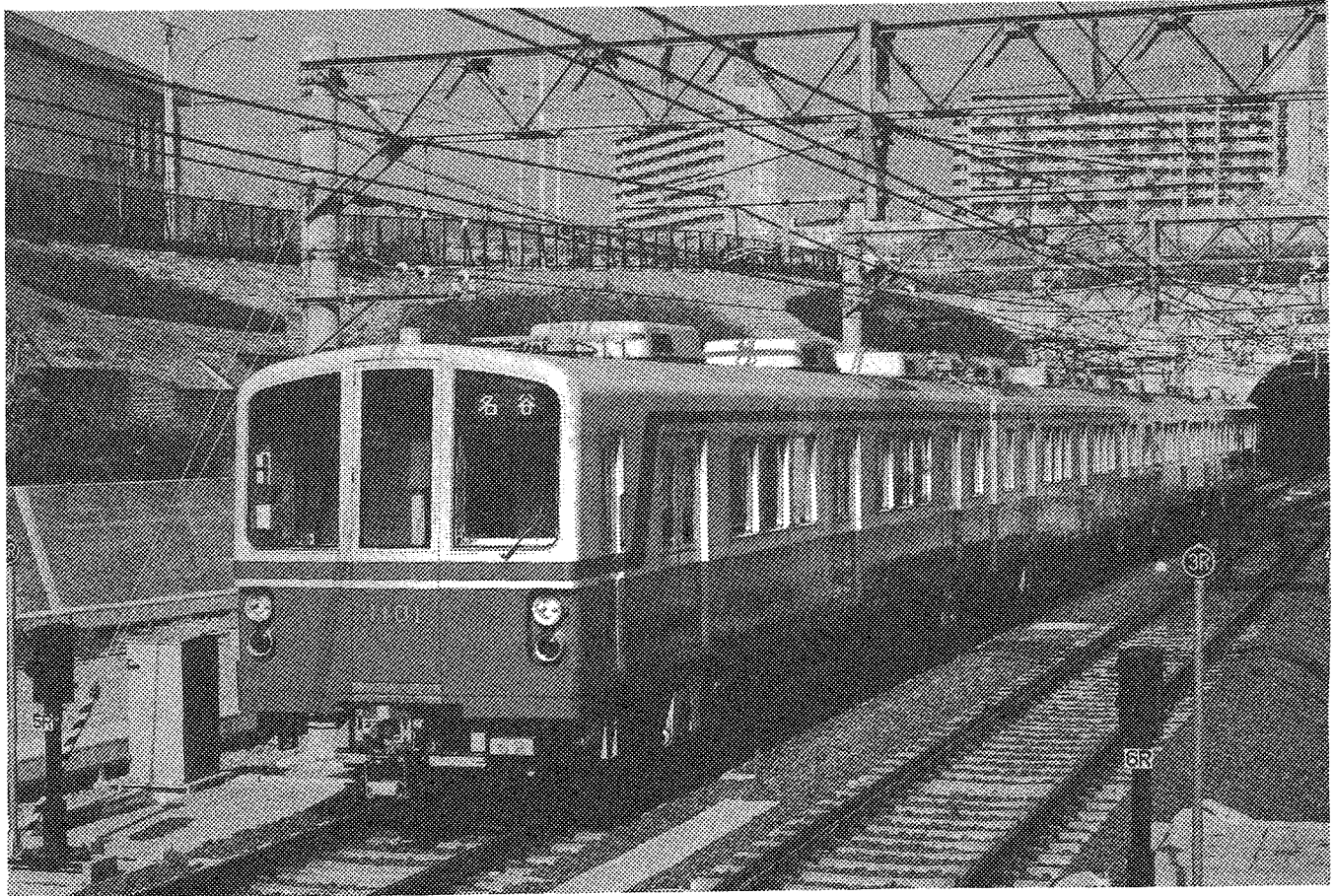

FIGURE A-14. 1000 SERIES CARS FOR SEISHIN LINE



- o Train consist            4M (now)  
                                 4M 2T (in future)
- o Passengers/train        580 (for 4M)
- o Maximum speed         75 km/h
- o Acceleration            3.3 km/h/s
- o Deceleration            3.5 km/h/s

Cars use regenerative braking to reduce energy consumption and reduce the heat load in the tunnel.

#### A.5.3 Inverter Substations and Energy Saving

The Seishin Line is characterized by steep gradients over long distances. As shown in Figure A-15, a train has to travel 1.56 km at 2.4 percent gradient between Myodani and Myohoji and 2.91 km at 2.9 percent between Myohoji and Itayado and further 1.19 km at 1.4 percent gradient. Thus some sustained braking is required to hold the vehicle speed within the maximum speed of 75 km/h. Under these conditions, regenerative braking is possible only if line receptivity is assured. The electric substations at Myodani and Itayado are, therefore, provided with regenerative inverter substations. The power supply schematic is shown in Figure A-16. The equipment ratings are:

- Inverter:                            1890 kW, 1640V, 1150 A, 3 phase  
   12 pulse, 300% overload for 1 minute
- Inverter Transformer:        33 kV/2 x 861 V  
   2710 / 2 x 1400 kVA  
   Star/Star-Delta, 300% overload for 1 minute
- Rectifier:                            2000 kW, 1500 V, 1333A, 3 phase  
   6 pulse, 150% overload for 2 hours,  
   300% overload for 1 minute

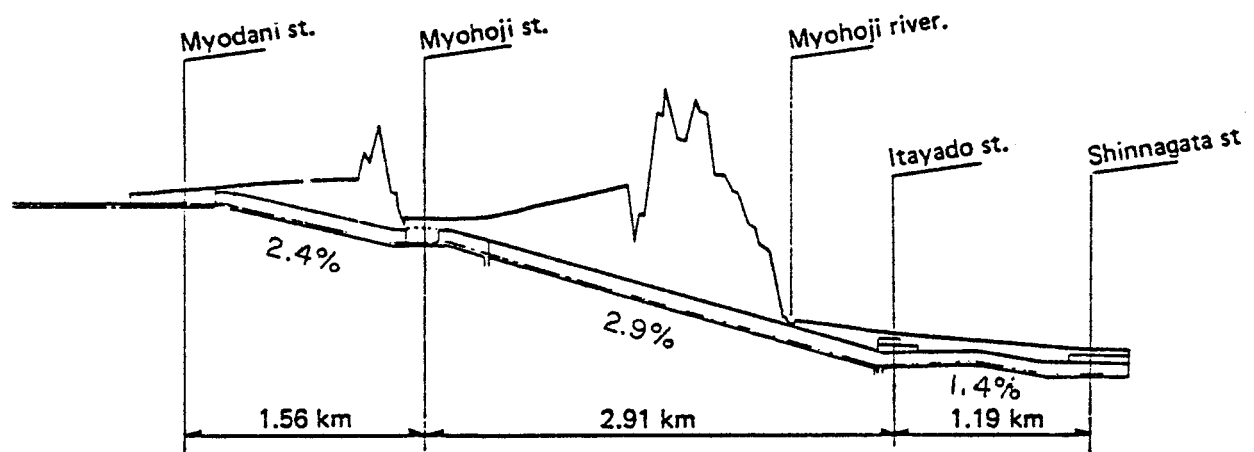

FIGURE A-15. PROFILE OF SEISHIN LINE

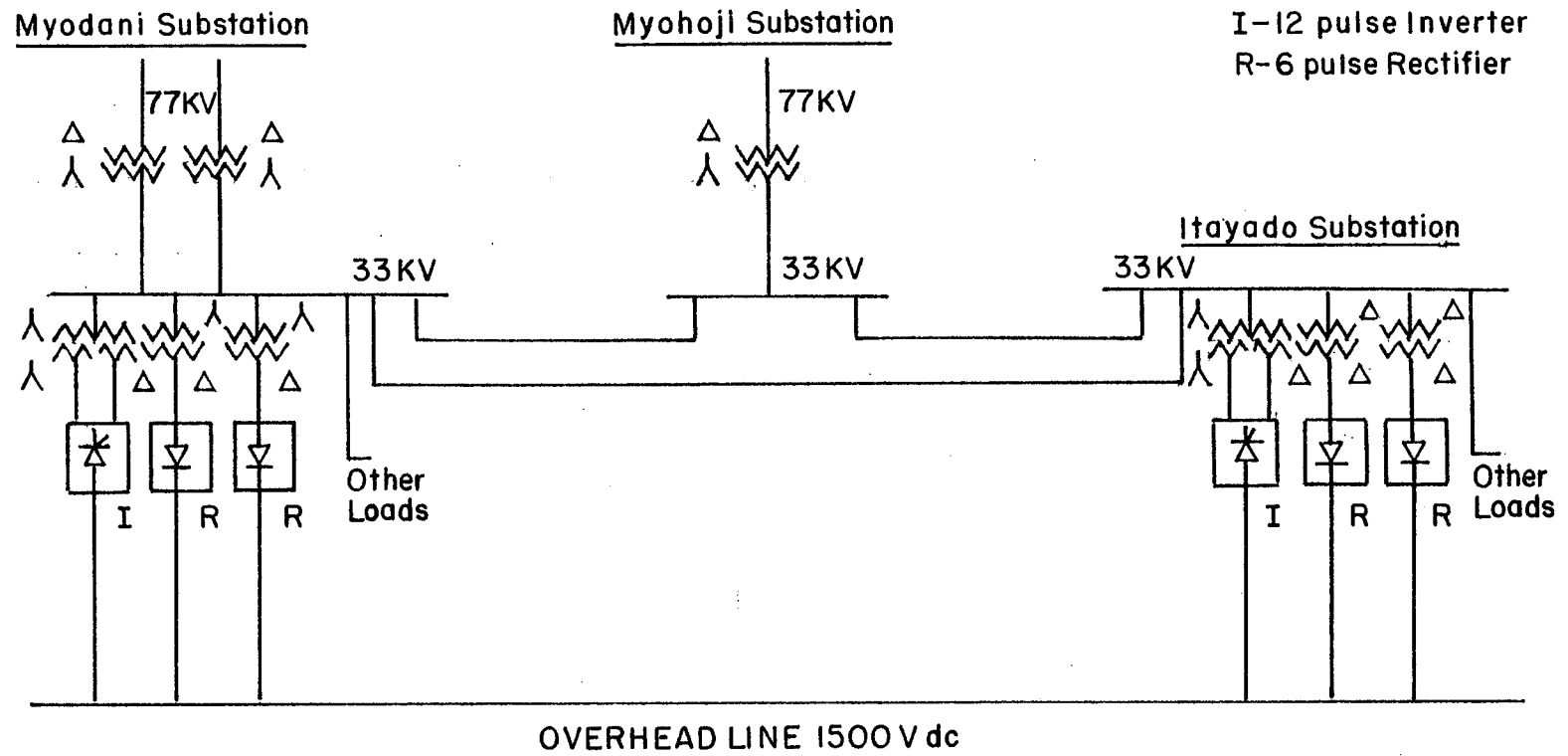

FIGURE A-16. POWER SUPPLY SCHEMATIC AT KOBE SUBWAY

Rectifier Transformer: 33 kV/1169 V  
 2200 kVA, 150% overload for 2 hours,  
 300% overload for 1 minute  
 Star/Delta at Myodani  
 Delta/Delta at Itayado

The total energy consumption and the energy returned by the inverters was measured at the two substations and this data is given in Table A-6.

TABLE A-6  
 Energy Consumption at Kobe Subway

<u>Year</u>	Total Energy Consumed $\times 10^6$ KWH	Energy Returned by the inverters $\times 10^6$ KWH	Energy returned, percent
1977	10.013	1.965	19.62
1978	9.304	1.946	20.91
1979	8.934	1.99	22.27

It can be seen that currently about 22 percent of the energy supplied from the rectifiers is being supplied to the ac system for running air conditioning, ventilation, and other equipment.

The harmonics in the line voltage and line current in 77 kV Kansai Electric line were measured for various operating conditions such as

- o Measurement at Myodani substation when
  - train is accelerating (inverter current zero)
  - train is decelerating to a stop (rectifier current zero)
  - train is running at constant speed (holding brake) between Myohoji & Itayado with rectifier current being zero
  - rectifier and inverter are both off, with only other non-propulsion loads on the 33 kV system.
- o Measurements with and without fifth and eleventh harmonic filters.

The maximum levels of harmonics measured during these tests are given in Table A-7 to indicate the orders of magnitude of these harmonics. In absence of any details regarding filters, input voltage unbalances, commutation reactances for the rectifier and inverter, etc., this data cannot be analyzed further and the reader is cautioned not to draw any specific conclusions from these numbers.

TABLE A-7

Voltage and Current Harmonics on 77 kV Line of Kansai Electric

Filter for harmonic order	Voltage Harmonic Content, percent maximum for harmonic orders					
	5	7	11	13	17	19
5, 11	0.27	0.13	0.19	0.14	0.06	0.09
11	0.52	0.28	0.15	0.18	0.05	0.04
--	0.5	0.15	0.17	0.13	0.06	0.09
Filter for harmonic order	Current Harmonic Content, percent maximum for harmonic orders					
	5	7	11	13	17	19
5, 11	17.5	10.53	12.17	6.86	2.18	2.17
11	18.25	9.019	12.96	5.50	2.09	2.20
--	28.65	12.49	22.26	8.45	2.25	3.44

A.5.4 Signalling System

Track circuits using double insulated rails are used in Kobe subway for both 60Hz and audio frequency circuits. The three frequencies used are 3420 Hz, 4140Hz and 4860Hz. The code rates used for cab signalling are:

<u>Speed</u> km/h	75	60	45	25	15	0	Stop
<u>Code rate</u> , Hz	28	34	39	45	53	73	CW

The minimum signal level is 100 mA and the maximum block length is 500m.

## A.6. KYOTO SUBWAY

Initial plans for Kyoto subway were drawn in 1968 although the actual construction began only in 1974. It has not begun its operations yet but a section of the Karasuma line will open very soon. Two lines covering 45 km are planned for this subway, and these lines will provide an access to JNR, Shinkansen, Keifuku Railway, Keihan Railway, Kinki Nippon Railway and Hankyu Railway.

### A.6.1 Planned Network

The two lines planned for this subway - Karasuma Line and Oike Line are shown in Figure A-17. The Karasuma Line will be 15 km long and a 6.9 km long section between Kitaoji and Kyoto is almost complete and will open very soon with a rolling stock of 9 trains in a 4M consist. Two sections - Kitayama to Kitaoji, and Kyoto to Takeda - are under construction now. The section between Takeda and Misu as well as the entire Oike line (30 km) from Nagaoka to Rokujizo are still under planning stage.

### A.6.2 Rolling Stock

The aluminum alloy cars being manufactured for service in Kyoto are shown in Figure A-18, and have the following specifications:

- o Traction motor: 130 kW, 375 V, 386 A  
1900 rpm, Class F, series wound
- o Chopper: 2 phase, 241 Hz per phase  
freon cooled, each unit controlling  
8 motors on two cars in 4S2P connection
- o Train consist: 4M
- o Passengers/train: 640

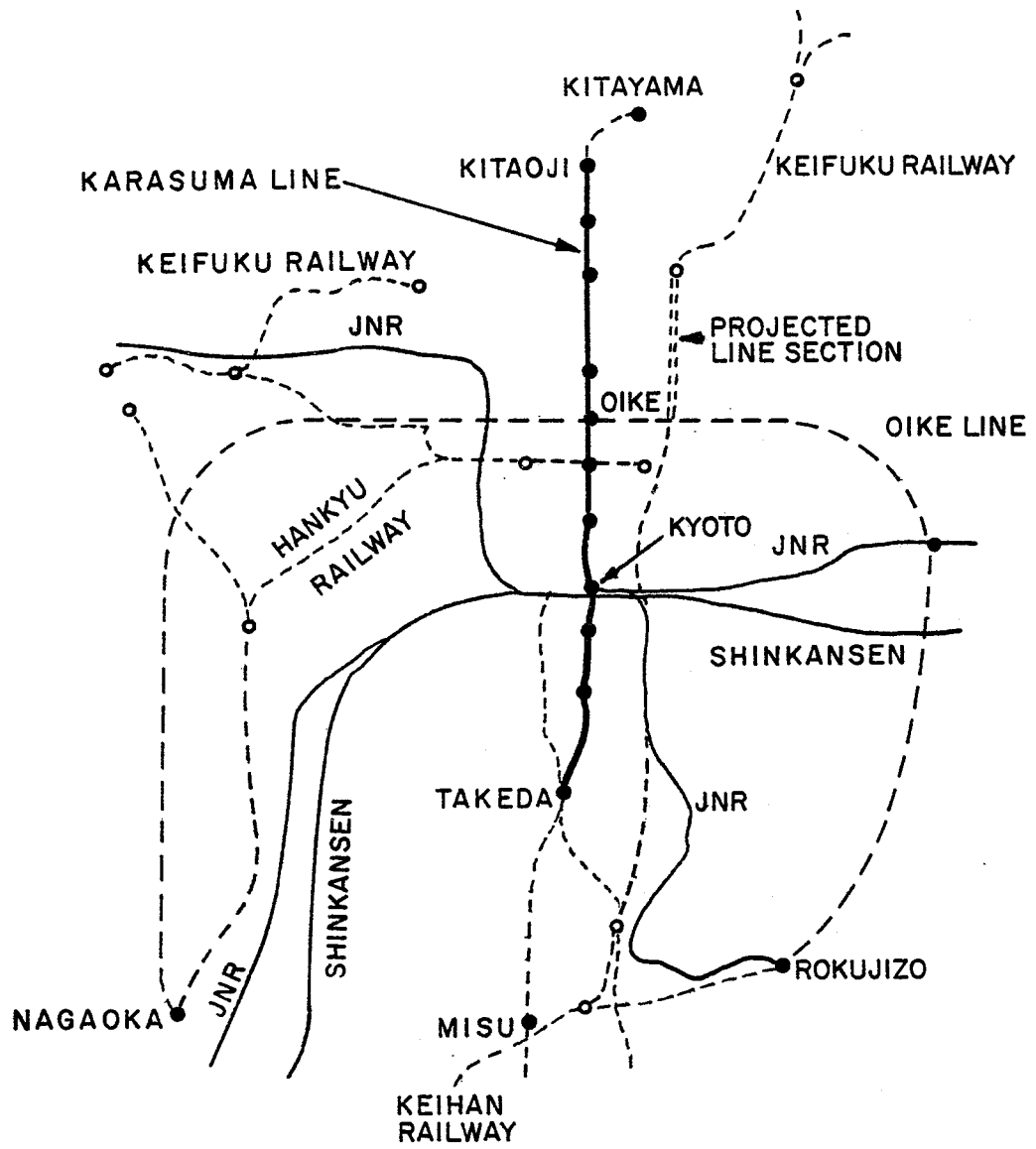

FIGURE A-17. PLANNED NETWORK FOR KYOTO SUBWAY

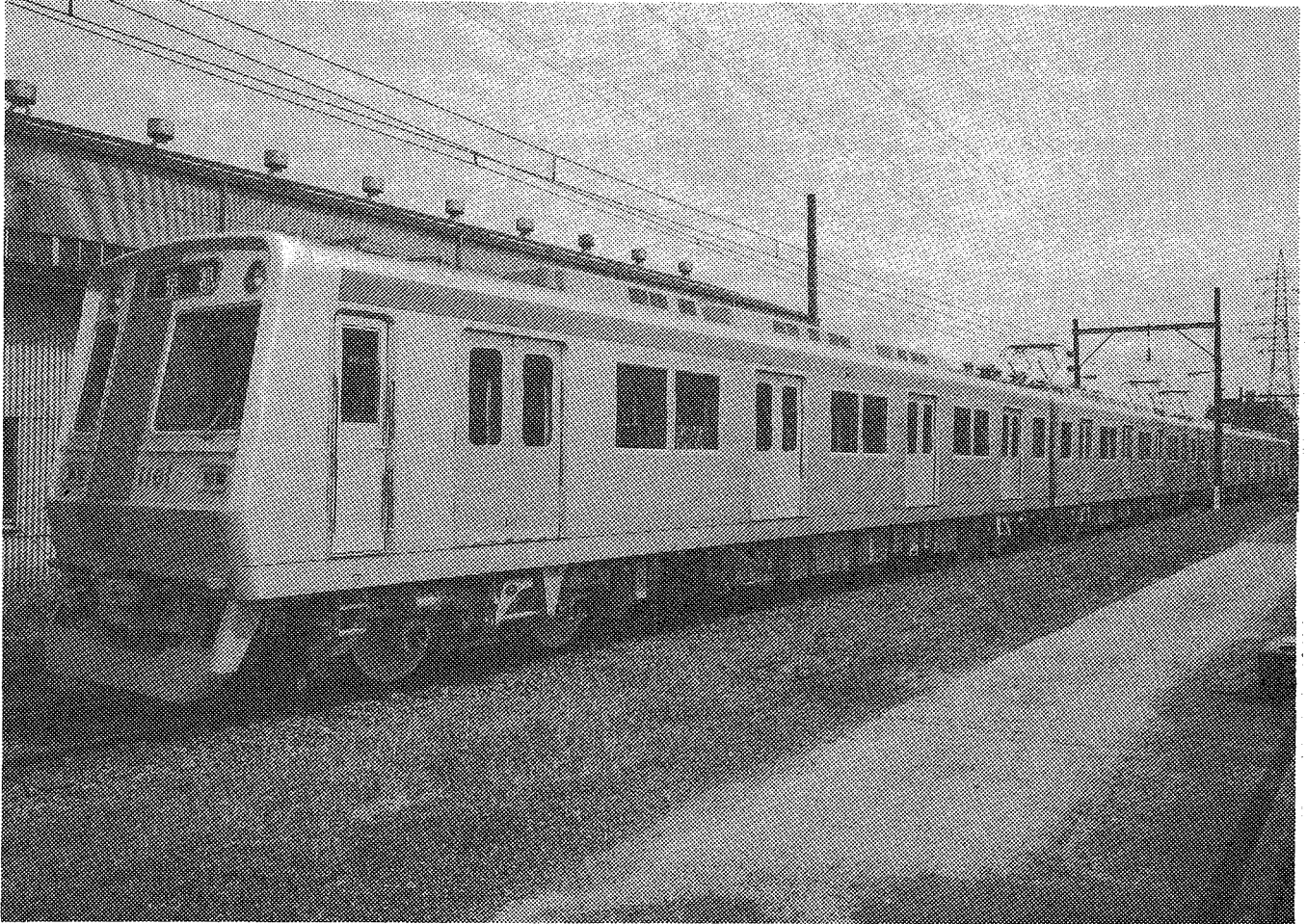

FIGURE A-18. 20 SERIES CARS FOR KYOTO SUBWAY



- o Maximum speed: 75 km/h
- o Acceleration: 3.3 km/h/s
- o Deceleration: 3.5 km/h/s

Cars will use regenerative braking.

#### A.6.3 Substation Equipment

The Karasuma Line has an overall negative gradient from Kitaoji to Kyoto. The substation at Oike is, therefore, an inverter station to assure line receptivity for regenerative braking.

#### A.6.4 Signalling System

The signalling system at Kyoto is similar to that at Nagoya. It uses four frequencies - 17.0 kHz, 18.0 kHz, 20.0 kHz and 21.0 kHz, - in addition to commercial frequency of 60 Hz. The code rates used for ATC are as follows:

<u>Speed, km/h</u>	75	60	45	25	15	0
<u>Code rate, Hz</u>	23	28	35	42	54	64

Train detection signal is coded at 144 Hz.

The minimum signal level is 50 mA and the maximum block level is 400 m.

#### A.6.5 Application of Advanced Technology

Freon cooled chopper equipment and inverter substation equipment will be operated on this subway when it opens.



## APPENDIX B

### OPERATION OF A COMMUTATION CIRCUIT

One of the most widely used commutation circuit in chopper cars on Japanese subways is shown in Figure B-1. The main thyristor MT and the auxiliary thyristor AT are both reverse conducting thyristors. The commutating reactor L also protects MT from high di/dt rates.

Before AT is triggered, the load current is flowing via A-MSL-MT-L as shown in Figure B-1. The capacitor C is charged as shown. Now when AT is triggered, a loop current  $i$  ( $V\sqrt{C/L} \sin \omega t$ ) flows in the AT-MT-L-C loop as shown in Figure B-2 A. This loop current  $i$  goes through one half cycle of oscillation and reverses. When the negative loop current equals  $I_L$ , the main thyristor MT is switched off. The circuit can now be redrawn as in Figure B-2 B. The circuit equations can be written as

$$L \frac{di}{dt} + v_c = 0$$

$$C \frac{dv_c}{dt} = i + I_L$$

with the initial conditions

$$i = 0 \quad \text{and} \quad v_c = -V^* \quad \text{at} \quad t = 0$$

The solutions to these equations can be written as

$$i = V^* \sqrt{C/L} \sin \omega t + I_L \cos \omega t - I_L$$

$$v_c = -V^* \cos \omega t + I_L \sqrt{L/C} \sin \omega t$$

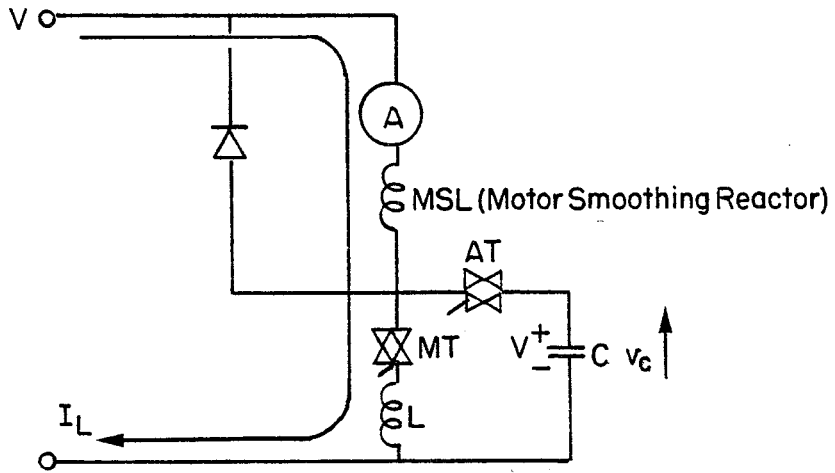

FIGURE B-1. COMMUTATION CIRCUIT

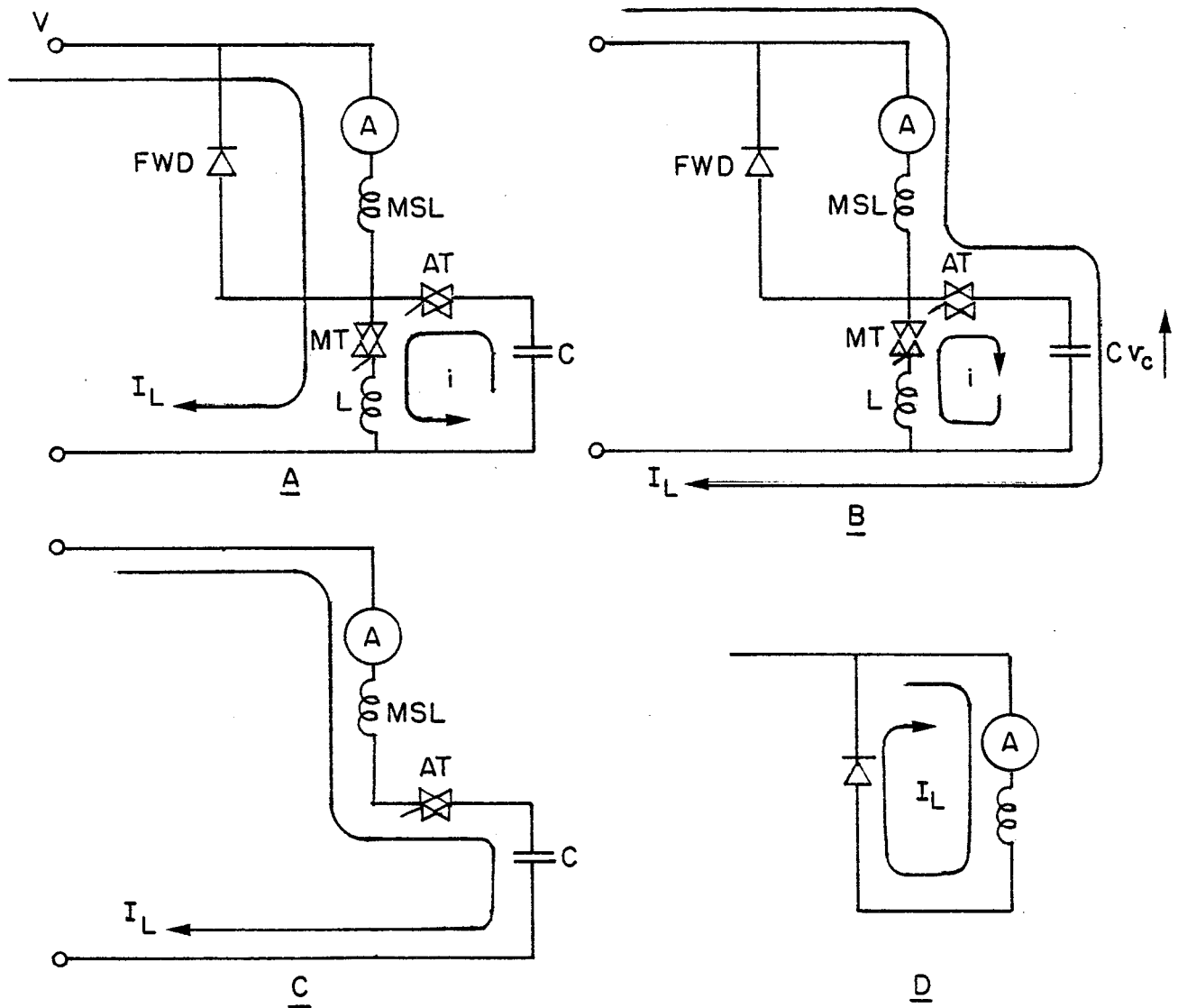

FIGURE B-2. COMMUTATION PROCESS

When the current  $i$  becomes zero, the LC oscillation terminates because AT (as well as MT) is not triggered and blocks. The load current then continues to charge the capacitor linearly and diverts to FWD when C is fully charged. This is shown in Figures B-2 C and B-2 D. The chopper can now be turned ON again when required.

Waveforms of current and voltages during commutation are shown in Figure B-3.

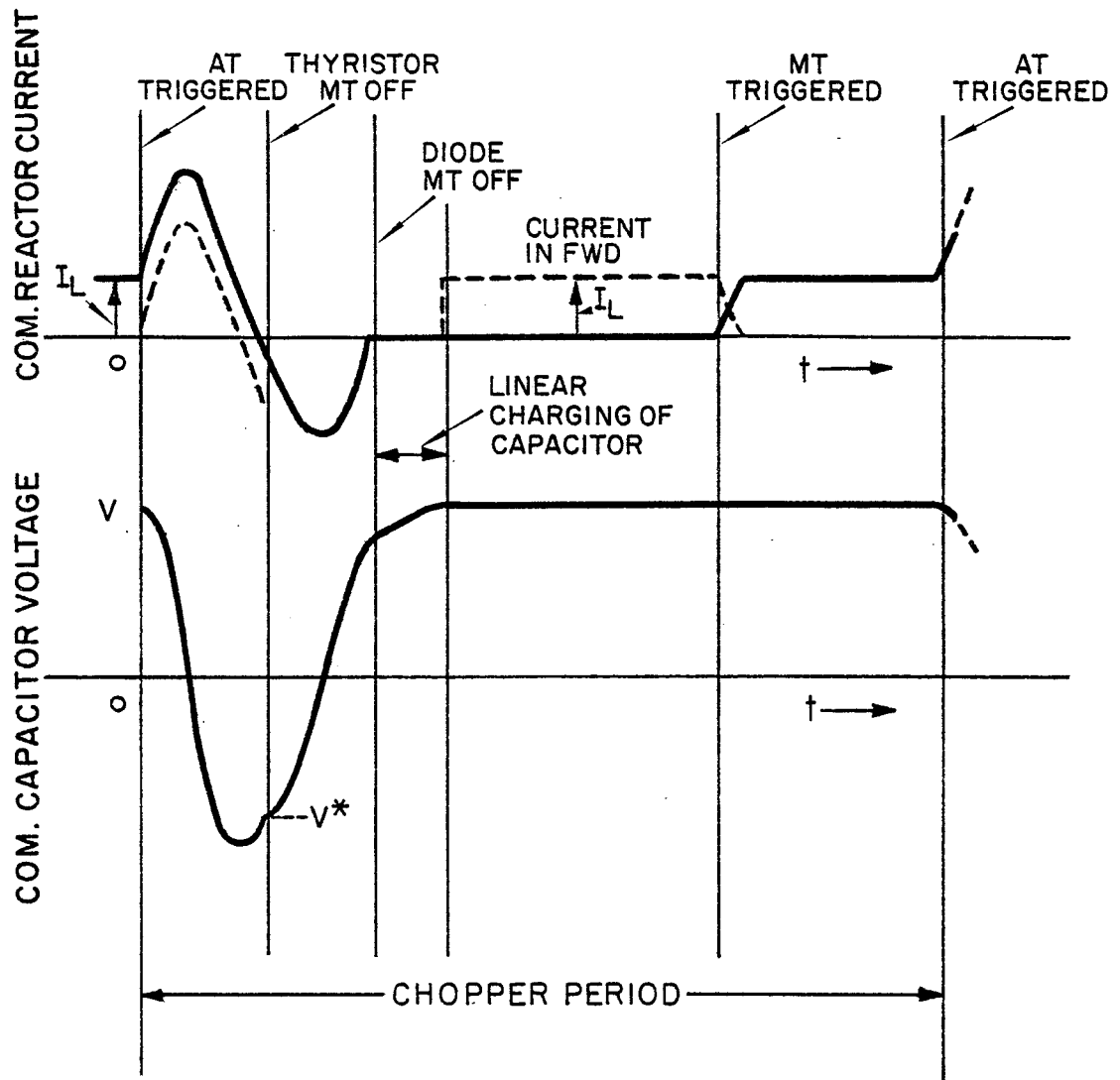

FIGURE B-3. WAVEFORMS DURING COMMUTATION

APPENDIX C  
REPORT OF NEW TECHNOLOGY

This report is an in-depth review of advanced propulsion technology used on urban and commuter rail vehicles in Japan. Although no new technology was developed in the course of this study, the information compiled will be very valuable to American transit properties implementing the same types of new propulsion equipment. Equipment modifications made by the Japanese in response to electromagnetic interference problems similar to those experienced in the U.S. have also been described.

## REFERENCES

1. Katta, T., "Thyristor Chopper - Controlled Electric Cars in Japan", Japan Railway Engineering, Vol. 20, No. 2, pp. 3-10, 1980.
2. Nene, V.D., "Electromagnetic Interference Characteristics of Advanced Propulsion Systems for Urban Rail Vehicles" Urban Mass Transportation Administration Report No. UMTA-VA-06-0075-81-1, 1981
3. "Thyristor Chopper Control and Harmonics to Audio Frequency (AF) Track Circuit", Private communication from Kyosan Electric Mfg. Co. Ltd, Tokyo, Japan
4. Jinzenji, T., "Thyristor Chopper Controller for Suburban Railcars, Toshiba Review, Sept/Oct 1974, pp. 1-8
5. --- , "Performance of Chopper Controlled Suburban Coaches", Private communication.
6. Yukawa, R., "Electromagnetic Compatibility between Thyristor-Chopper Controlled Cars and Electric Fixed Installations in Tokyo Subway", Mitsubishi Electric Corporation Report HCN-Q1462
7. Tachibana, K., et al., "Harmonic Currents in Catenary Systems from Chopper Control", Trans. IEEE, Vol. IA-8, No. 2, pp. 203-10, 1972.
8. Nene, V.D., "The Status of Advanced Propulsion Systems for Urban Rail Vehicles", Urban Mass Transportation Administration Report UMTA-VA-06-0053-79-1, 1979.
9. Katta, T., "Thyristor Control of Traction Motors", Presented at the UITP Chopper Group meeting at Tokyo, November 1980.
10. Katta, T., et al., "Induction Motor Propulsion System for Transit Cars", Hitachi Review, Vol. 29, No. 1, pp. 19-24, 1980.







U.S. Department  
of Transportation

**Research and  
Special Programs  
Administration**

Kendall Square  
Cambridge, Massachusetts 02142

Postage and Fees Paid  
Research and Special  
Programs Administration  
DOT 513



Official Business  
Penalty for Private Use \$300