



U.S. Department
of Transportation
**Federal Railroad
Administration**

RIDE QUALITY EVALUATION OF HIGH SPEED TRAINS ON THE NORTHEAST CORRIDOR

Office of Research and
Development
Washington D.C. 20590



PB98-107162

DOT/FRA/ORD-96/07

September 1996
Final Report

This document is available to the U.S.
public through the National Technical
Information Service, Springfield, VA 22161



NOTICE

This document is disseminated under the sponsorship of the Department of Transportation in the interest of information exchange. The United States Government assumes no liability for its contents or use thereof.

NOTICE

The United States Government does not endorse products or manufacturers. Trade or manufacturers' names appear herein solely because they are considered essential to the object of this report.

NOTICE

In numerous places, this report discusses whether various aspects of the technology that is the subject of this report comply with Federal safety laws and regulations. Those discussions, which reflect the seasoned judgment of commentators qualified in their fields, do not constitute rulings by the Federal Railroad Administration's Office of Safety or its Office of Chief Counsel concerning compliance with the law.

REPORT DOCUMENTATION PAGE

Form Approved
OMB No. 0704-0188

Public reporting burden for this collection of information is estimated to average 1 hour per response, including the time for reviewing instructions, searching existing data sources, gathering and maintaining the data needed, and completing and reviewing the collection of information. Send comments regarding this burden estimate or any other aspect of this collection of information, including suggestions for reducing this burden, to Washington Headquarters Services, Directorate for Information Operations and Reports, 1215 Jefferson Davis Highway, Suite 1204, Arlington, VA 22202-4302, and to the Office of Management and Budget, Paperwork Reduction Project (0704-0188), Washington, DC 20503

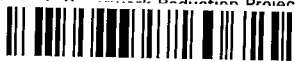

PB98-107162

2. REPORT DATE
September 1996

3. REPORT TYPE AND DATES COVERED
Final Report

4. TITLE AND SUBTITLE
RIDE QUALITY EVALUATION OF HIGH SPEED TRAINS ON THE NORTHEAST CORRIDOR

5. FUNDING NUMBERS
DTFR53-90-C-00021

6. AUTHOR(S)
Brian E. Mee/ENSCO

7. PERFORMING ORGANIZATION NAME(S) AND ADDRESS(ES)
ENSCO, Inc.
Applied Technology and Engineering Division
5400 Port Royal Road
Springfield, VA 22151

8. PERFORMING ORGANIZATION
REPORT NUMBER
DOT-FRA-96-05

9. SPONSORING/MONITORING AGENCY NAME(S) AND ADDRESS(ES)
U.S. Department of Transportation
Federal Railroad Administration
Office of Research and Development
400 Seventh Street, S.W.
Washington, DC 20590

10. SPONSORING/MONITORING
AGENCY REPORT NUMBER
DOT/FRA/ORD-96/07

11. SUPPLEMENTARY NOTES

Detailed information, including track geometry data, tangent track data, curving track data, interlocking data, ride quality exception data, locomotive data, and test logs are available at the FRA Office of Research and Development and at ENSCO, Inc.

12a. DISTRIBUTION/AVAILABILITY STATEMENT

This document is available to the public through the National Technical Information Service, Springfield, VA 22161

12b. DISTRIBUTION CODE

13. ABSTRACT (Maximum 200 words)

A portable system to allow collection and analysis of carbody vibration data according to ISO standard 2631 was designed and built. This system allowed the FRA to record and compare the ride quality performance of foreign and domestic high speed trains operating in revenue service on the Northeast Corridor (NEC). Test data was collected on the Swedish X2000, the German ICE, the Spanish Talgo, and on the standard Amtrak Metroliner.

The portable ride quality system consisted of a sensor unit containing accelerometers, power supply, analog to digital converter, and signal conditioning equipment. This sensor unit communicated with a laptop computer via a parallel port interface. The system could collect, store, and display two channels of acceleration data at rates of up to 200 samples per second. Software was written for the laptop computer to allow rapid data analysis in a post-processing mode. Time histories, frequency spectrum, and peak-to-peak events could be displayed on the screen or plotted by laser printer.

Analysis of lateral and vertical ride quality was made in both the frequency and time domains. ISO 2631 reduced comfort level exposure times were calculated for all of the trains on selective tangent and curving track test zones.

The X-2000 train set was found to have better ride quality in the vertical direction. The X-2000 and the ICE train sets provided about equivalent ride for lateral vibration on tangent track. The X-2000 and the ICE, at a higher speed, provided essentially equivalent ride on curving track as the Metroliner. The Talgo provided good ride on tangent track at high speeds tested but had a high level of lateral acceleration at approximately 1 Hz on jointed tracks at speeds between 30-45 mph.

14. SUBJECT TERMS

High-Speed Rail, Cant Deficiency, Safety, Tilt Train, Lateral Acceleration, Curving, Vehicle Dynamics, Safety Regulations, Ride Quality

15. NUMBER OF PAGES

16. PRICE CODE

17. SECURITY CLASSIFICATION
OF REPORT
Unclassified

18. SECURITY CLASSIFICATION
OF THIS PAGE
Unclassified

19. SECURITY CLASSIFICATION
OF ABSTRACT
Unclassified

20. LIMITATION OF ABSTRACT
Unclassified

RIDE QUALITY EVALUATION OF HIGH SPEED TRAINS ON THE NORTHEAST CORRIDOR

TABLE OF CONTENTS

<u>Section</u>	<u>Page</u>
EXECUTIVE SUMMARY	iii
1. GENERAL.....	1
1.1 INTRODUCTION	1
1.2 TEST OBJECTIVE	1
1.3 OVERVIEW OF PROGRAM.....	1
2. RIDE QUALITY TESTING	2
2.1 TEST CONSIST / MEASUREMENT LOCATIONS.....	2
2.1.1 X2000	2
2.1.2 Inter City Express ICE.....	3
2.1.3 Metroliner	5
2.2 TEST ZONES.....	7
2.3 TEST SCHEDULE.....	9
2.3.1 X2000	9
2.3.2 ICE.....	9
2.3.3 Metroliner.....	10
2.4 TEST EQUIPMENT AND PROCEDURE.....	10
2.4.1 Test Equipment Overview.....	10
2.4.2 Test Logs.....	13
2.4.3 Speed Profiles	14
2.4.4 Test Safety.....	16

3. ANALYSIS	16
3.1 FREQUENCY DOMAIN ANALYSIS	19
3.1.1 Tangent Track Frequency Analysis	20
3.1.2 Curving Track Frequency Analysis	26
3.2 TIME DOMAIN ANALYSIS	36
3.2.1 Elmora Interlocking	36
3.2.2 County Interlocking	38
3.2.3 Ride Quality Exception Zone Q3.....	38
3.2.4 Ride Quality Exception Zone Q6.....	40
4. TALGO RIDE QUALITY EVALUATION	42
4.1 TALGO TEST SCHEDULE.....	42
4.2 TALGO CONSIST	43
4.3 TALGO DATA ANALYSIS	43
4.3.1 Tangent Track.....	44
4.3.2 Curving Track	45
4.3.3 Time Domain Analysis	47
4.4 TALGO SUMMARY	50
5. CONCLUSIONS.....	51
6. REFERENCES	52
APPENDIX A Operating Instructions, Portable Ride Quality Measurement System	A-1

Detailed information, including track geometry data, tangent track data, curving track data, interlocking data, ride quality exception data, locomotive data, and test logs are available at the FRA Office of Research and Development and at ENSCO, Inc.

EXECUTIVE SUMMARY

Ride quality measurements were taken on three different types of high speed trains on the Northeast Corridor between Washington, DC and New York City. The amount of vibration in the vertical and lateral directions were recorded on the Swedish X2000, the German Intercity Express (ICE), and a standard Amtrak Metroliner with one AEM-7 electric locomotive, using a portable ride quality data collection system. These tests were conducted by ENSCO, Inc. during simulated and actual revenue service in the fall and winter of 1993 to provide quantitative comparison data to the Federal Railroad Administration (FRA).

The three trains had nearly the same level of comfort during high speed travel on tangent track. However, the ICE and the X2000 provided this ride quality while traveling at least 15 mph faster than the Metroliner.

On curving track, the X2000 had the lowest steady-state lateral acceleration due to its tilt body system. All three trains had about the same level of lateral and vertical vibration. However, the ICE and X2000 achieved this vibration level at speeds 10-15 mph faster than the Metroliner.

The X2000 had better ride quality through track disturbances such as interlockings than the other two trains. The X2000 Cab car with its heavily ballasted truck provided a better ride than the other vehicles.

The ICE and X2000 locomotives provided less vertical vibration at high speed in the cab than the current AEM-7 locomotive.

The AEM-7 and X2000 locomotives provided slightly less lateral vibration at high speed than the ICE locomotive. The X2000 locomotive had better ride quality through interlockings at low speed than the other locomotives. The AEM-7 at high speed had worse ride quality through interlockings than the ICE or X2000 locomotives.

In addition, the Talgo passive tilt train was later tested on the Northeast Corridor between Washington, DC and Philadelphia at a maximum speed of 110 mph. The Talgo provided a high level of comfort at high speed on welded rail. At low speeds on jointed rail, the lateral ride quality showed the dominance of the natural frequency of the passive tilt system.

1. GENERAL

1.1 INTRODUCTION

This document contains the results of testing to characterize the ride quality of high speed rail passenger vehicles. The lateral and vertical acceleration and vibration of standard Amtrak Metroliners, the Swedish X2000, and the German Intercity Express (ICE), were recorded during simulated and actual revenue service on the Northeast Corridor (NEC) between Washington, DC Union Station (WAS) and New York City Penn Station (NYP). The ride vibration environment was evaluated using current Amtrak ride quality criteria, and the International Organization for Standardization (ISO) standard 2631 "Guide for the Evaluation of Human Exposure to Whole-body Vibration". Data were collected for locomotives and coaches. The response to specific track features such as interlockings was compared using peak-to-peak acceleration values. The ride quality experienced in steady-state operation on tangent or curving track was compared using ISO 2631 "Reduced Comfort Boundary" vibration exposure levels. The ISO exposure levels were calculated using a "snapshot", generally of 8192 data points, corresponding to approximately 41 seconds of travel.

1.2 TEST OBJECTIVE

The test objective was to collect technical data and provide a quantitative evaluation of the ride quality characteristics of high speed rail vehicles proposed for passenger transportation in the U.S. A portable ride quality data collection and analysis package was developed for future use by the FRA.

1.3 OVERVIEW OF PROGRAM

The test program involved a series of carbody acceleration measurements taken on each subject train while in regular passenger service on the NEC. Data was recorded throughout the NEC between WAS and NYP for each train tested. Acceleration data was recorded on the floor of each vehicle rather than on passenger or crew seats. Initial test runs identified specific track locations that were then analyzed in detail for each train type.

In order to collect data on the X2000 prior to its removal from revenue service, a non-portable ride quality data collection system was assembled that recorded acceleration data on a digital audio tape (DAT) recorder. This system was also used for data recording on the ICE coach. The DAT data tapes were processed to create digital disk files for analysis at ENSCO. During the initial test period, a PC-based portable ride quality data collection system, and ride quality analysis software were developed, designed, and constructed. This system was used for data collection on the Metroliner

coaches, AEM-7 locomotive, ICE locomotive, and TALGO coaches. The system was also used to analyze the ride quality data.

2. RIDE QUALITY TESTING

2.1 TEST CONSIST / MEASUREMENT LOCATIONS

All NEC tests were conducted during normal revenue service, with the exception of the ICE coach data obtained during a crew training run on October 1, 1993.

A file naming convention was developed to identify the vehicle type, the measurement location inside the vehicle, the track number, and the type of test zone of track for each data set. This code was also used on plots of the resulting data.

Table 2.1 Data Naming Convention

Vehicle Code	Measurement Location Code	Track Number	Test Zone Code
X = X2000 I = ICE M = Metroliner	COT = Coach over truck at trailing end COL = Coach over truck at leading end LOL = Locomotive at leading end CAL = Cab car at leading end	2 or 3	I# = Interlocking T# = Tangent Track C# = Curved Track Q# = Ride Quality Exception

2.1.1 X2000

The X2000 trainset was tested first since it was scheduled to be withdrawn from revenue service on September 24, 1993. The locomotive, cab car and coach car trucks utilize soft longitudinal suspensions that permit the wheel-rail forces to generate a self steering action. The cab car and coaches have an active tilting system which provides up to 8° of tilt in curves.[1] The outboard cab car truck is ballasted with approximately 11,000 pounds of weight for stability under wind loading conditions. The X2000 trainset included the following equipment:

Table 2.2 X2000 Test Consist

Car Type	ABB Car Class	Car Number
Locomotive	X2	2013 *
Coach	UA2	2719 *
Coach	UA2	2718
First Class Buffet	UAR2	2609
Coach	UA2	2810
Cab Car	UA2X	2511 *

* Measurement locations

The locomotive led the test consist when travelling from Washington to New York. The cab car led the consist from New York to Washington.

2.1.1.1 X2000 Coach

The accelerometers were placed under seat no. 1 of the coach car. This was the first single seat on the left side of the train which allowed a good view of the mileposts. The accelerometer plate was located 14 inches from the bulkhead forming a closet, and 2 inches inboard of the outside wall of the coach. The accelerometer power supply was located behind seat no.1 and the DAT recorder was placed on a pull-down tray table at seat no.1.

2.1.1.2 X2000 Locomotive

The accelerometers were placed under the engineer's foot board. The accelerometer plate was located 12 inches from the left outside wall and 12 inches from the forward bulkhead. The accelerometer power supply was located under the observer's seat and the DAT recorder was placed on the top of the instrument panel.

2.1.1.3 X2000 Cab Car

The accelerometers were placed under the engineer's foot board. The accelerometer plate was located 12 inches from the left outside wall and 12 inches from the forward bulkhead. The accelerometer power supply was located under the observer's seat and the DAT recorder was placed on the top of the instrument panel.

2.1.2 Inter City Express ICE

The ICE coach trucks had a primary suspension of coil springs in parallel with hydraulic dampers. The secondary suspension consisted of two coil springs on each side between the bolster and a spring attachment to the side frame connected through a pendulum. Rubber-metal elements were used between the springs and spring attachments for noise control. The bolster had hydraulic dampers to absorb cross motions. The ICE power car trucks had a primary suspension consisting of a pair of coil

springs at the journals in parallel with hydraulic dampers. The power car secondary suspension consisted of four groups of coil springs mounted on the side beams of the trucks. A hydraulic damper was in parallel with the secondary suspension. Horizontal dampers and yaw dampers were also fitted to the power car trucks.[2]. The ICE does not have tilting capability. The ICE trainset included the following equipment:

Table 2.3 ICE Test Consist

Car Type	Car Class	Car Number
Power Unit A	PU	401.084 *
2nd Class Coach	Bvmz	802.855 *
2nd Class Coach	Bvmz	802.657
2nd Class Coach	Bvmz	802.438
2nd Class Coach w/handicapped toilets and special compartments	BSmz	803.056
Restaurant Coach	WSmz	804.051
1st Class Coach	Avmz	801.856
Power Unit B	PU	401.584 *

* Measurement locations

Acceleration data was recorded in both Power Units and in Bvmz second class coach S/N 802.855. This coach was originally used as the instrumentation car during initial safety testing of the ICE. It was therefore equipped with non-resilient wheels. During the ride quality tests, the non-resilient wheels were still in place. All of the other coaches have resilient wheels. The effect of non-resilient wheels would be felt in the high frequency range and would not be expected to alter vibration modes at low frequencies.

2.1.2.1 ICE Coach

The accelerometers were placed in two locations during coach testing of the ICE. On the October 1 test during a crew training run, the accelerometer plate was placed under outboard seat no. 17 at the trailing end of the coach in a position 5 inches aft of the vestibule partition and 2 inches from the outside wall. During this test, the coach was oriented so that this seat was on the left side of the train facing forward for the WAS to NYP run on track 2. This data is referred to as coach trailing on track 2. The plate was left in position for the return trip on track 3. Data from that run was referred to as coach leading on track 3. The accelerometer power supply was placed under a seat and the DAT recorder was placed on the table of the four seat section. An oscilloscope was used to monitor the accelerometer readings in real time.

On the revenue run of October 5, the ICE consist had been reversed from its orientation on October 1. The section of the car containing seat no. 17 was now at the leading end of the car for track 2 and data from this run was designated as coach leading track 2. The accelerometers were placed in the aisle at the car lateral centerline and placed at the midpoint of the truck on that end of the car. This position was approximately 3 ft.

closer to the car's longitudinal midpoint than the runs on October 1. A second vertical accelerometer mounted on a wooden block was placed under the outboard seat in line with the centerline of the truck. The accelerometer power supply was placed under a seat and three 100 Hz low pass filters were placed under the table of the four-seat section. A four channel strip chart recorder was used to monitor the accelerometer readings. Accelerometer voltages were lead to "T" connectors at the low pass filters such that raw voltages were recorded on the DAT recorder and filtered signals were sent to the strip chart.

On the return run on track 3, the equipment was left in position in what was now the trailing end of the car, and this data is referred to as coach trailing track 3.

2.1.2.2 ICE Locomotive

The portable ride quality unit was placed on the centerline of the locomotive approximately 6 inches aft of the vertical portion of the engineer's station. The laptop computer was placed on the top of the instrument panel at the observer's seat.

2.1.3 Metroliner

Measurements were made in two different Metroliner AMFLEET coaches and in one AEM-7 locomotive. Each Metroliner train consisted on one leading AEM-7 pulling four coaches and one AMCAFE car. The Metroliner coach truck primary suspension consisted of four stiff rubber rings between the axle and side frame. The secondary suspension contained coil springs in series with air springs. Motion in the vertical and lateral directions were damped by rotary shock absorbers. Two anchor rods on each truck were connected between the bolster and the carbody.[3]

Table 2.4 Metroliner Test Consist 11/30/93 WAS-NYP Track 2

Car Type	Car Class	Car Number
Locomotive	AEM-7	938*
Coach	AMCOACH	
Coach	AMCOACH	
Coach	AMCOACH	
Coach	AMCOACH	
Diner/Snack	AMCAFE	

* Measurement location

Table 2.5 Metroliner Test Consist 11/30/93 NYP-WAS Track 3

Car Type	Car Class	Car Number
Locomotive	AEM-7	
Coach	AMCOACH	21956*
Coach	AMCOACH	
Coach	AMCOACH	
Coach	AMCOACH	
Diner/Snack	AMCAFE	

* Measurement location

Table 2.6 Metroliner Test Consist 12/22/93 WAS-NYP Track 2

Car Type	Car Class	Car Number
Locomotive	AEM-7	
Coach	AMCOACH	
Coach	AMCOACH	
Coach	AMCOACH	
Coach	AMCOACH	44914*
Diner/Snack	AMCAFE	

* Measurement location

Table 2.7 Metroliner Test Consist 12/22/93 NYP-WAS Track 3

Car Type	Car Class	Car Number
Locomotive	AEM-7	
Diner/Snack	AMCAFE	
Coach	AMCOACH	44914*
Coach	AMCOACH	
Coach	AMCOACH	
Coach	AMCOACH	

* Measurement location

2.1.3.1 Metroliner Coach

Measurements were made on coach S/N 44914 in both directions on the NEC, and on coach 21956 on track 3 only. Coach S/N 21956 was the second coach behind the leading AEM-7 locomotive. Coach S/N 44914 was also the second car behind the leading AEM-7 locomotive on track 3 and the fourth car behind the locomotive on track 2. Accelerations on both coach S/N 44914 and S/N 21956 were measured by placing the ride quality unit approximately 6 inches from the outside wall and over the center of the truck. The measurement position was over the trailing truck on both S/N 21956 and S/N 44914 on track 2. The measurement position was over the leading truck on S/N 44914 on track 3. The Metroliner coaches are not turned on a "Y" at New York, but the seat orientation is reversed between runs. The laptop computer was placed on a pull-down tray at the seat.

2.1.3.2 Metroliner Locomotive

Measurements were made in the cab of the AEM-7 locomotive S/N 938 on track 2 only. The AEM-7 was in the lead position. In the AEM-7 locomotive cab, the ride quality package was placed in the footwell on the left side of the cab approximately 12 inches from the outside wall and 12 inches aft of the forward bulkhead. The laptop computer was placed on the top of the instrument panel at the observer's seat.

2.2 TEST ZONES

In all cases, data was recorded over the entire route in both directions with small gaps due to tape changing, file renaming, or other operational restrictions. Test areas for specific analysis were identified in the test plan prior to testing on the NEC. These test zones included tangent track in good condition, curves in either direction with associated spirals, interlockings, and areas of rough track as shown in Tables 2.8 and 2.9. Locations of reported Amtrak ride quality exceptions were added after completion of the X2000 and ICE coach tests.

Table 2.8 Test Zones Washington - Philadelphia

Type	Code	Milepost	Track	Normal Speed	Comments
Tangent Track	T1	125-121	2,3	125	Curve 406 in middle
Tangent Track	T2	75-74.2	2,3	125	Between Edgewood and Bush interlockings, curve 355 in middle
Curve #387-390	C1	103-106	2,3	110	Halethorp-BWI stations
Curve # 359-364	C2	85.8-89	2,3	110	E of River Interlocking
Curve #344-347	C3	53-57	2,3	105-125	E of Prince Interlocking
Interlocking	I1	98.2	3	50	Bridge Interlocking
Reported Ride Quality Exception	Q1	83.8	3	125	Hot Box/Dragging Equipment Detector
Reported Ride Quality Exception	Q2	75.3	3	125	Edgewood Interlocking
Reported Ride Quality Exception	Q3	73.9-74	2,3	125	Curve 355
Reported Ride Quality Exception	Q4	71.4-72.3	3	125	Bush Interlocking and Bush River Drawbridge
Reported Ride Quality Exception	Q5	63.1	2	110	Oak Interlocking
Reported Ride Quality Exception	Q6	15.1-12.8	2	90	Numerous under grade bridges

Table 2.9 Test Zones Philadelphia - New York

Type	Code	Milepost	Track	Normal Speed	Comments
Tangent Track	T3	39.5-34	2,3	125	E of Midway Interlocking to W of County
Tangent Track	T4	55-42	2,3	125	E of Fair Interlocking to W of Midway Interlocking
Curve # 254-258	C4	18-20	2,3	125	MP 18- to Union Interlocking
Curve # 275-276	C5	39-40	2,3	125	E of Midway Interlocking
Curve #290-292	C6	74-76	2,3	90	Reverse curves
Interlocking	I2	14.7	3	55	Elmora Interlocking
Interlocking	I3	33	3	125	County Interlocking
Interlocking	I4	65	3	115	Grundy Interlocking
Interlocking	I5	41	2,3	125	Midway Interlocking

Data was recorded at each of these locations for all of the test vehicles. When testing was completed, data from all of the zones were compared to identify a smaller number of test zones that would be representative for the time domain and frequency analyses. Table 2.10 contains the zones that were selected to represent good tangent track, smooth and rough curves, high speed and medium speed interlockings, and areas of known ride quality exceptions.

Table 2.10 Test Zones Used for Analysis

Type	Code	Milepost	Track	Normal Speed	Comments
Tangent Track	T4	55-42 (PHL-NYP)	2,3	125	E of Fair Interlocking to W of Midway Interlocking
Interlocking	I2	14.7 (PHL-NYP)	3	55	Elmora Interlocking
Interlocking	I3	33 (PHL-NYP)	3	125	County Interlocking
Curve # 254-258	C4	18-20 (PHL -NYP)	2,3	125	MP 18- to Union Interlocking
Curve # 275-276	C5	39-40 (PHL-NYP)	2,3	125	E of Midway Interlocking
Curve #290-292	C6	74-76 (PHL-NYP)	2,3	90	Reverse curves
Reported Ride Quality Exception	Q3	73.9-74 (PHL-WAS)	2,3	125	Curve 355
Reported Ride Quality Exception	Q6	15.1-12.8 (PHL-WAS)	2	90	Numerous under grade bridges

2.3 TEST SCHEDULE

2.3.1 X2000

X2000 testing occurred on September 23 and 24, 1993. Cab car and coach leading data was recorded on September 23rd. Coach trailing and locomotive leading data was recorded on September 24th.

2.3.2 ICE

ICE testing began on October 1, 1993 with coach-trailing data from WAS to NYP and coach-leading data from NYP to WAS. A large portion of the NYP-WAS trip on this date was made on track 4, not the desired track 3. ICE coach testing was repeated on October 5, 1993. On this date, the train was oriented differently so that the test coach car was in the leading position on track 2 from WAS to NYP, and in the trailing position from NYP to WAS on track 3. Data on the locomotives in the leading position from WAS to NYP and from NYP to WAS, was collected on December 11, 1993.

2.3.3 Metroliner

Data on the AEM-7 locomotive was recorded from WAS to NYP on track 2 on November 11, 1993. Metroliner coach data was collected on November 11, 1993 on Amfleet car S/N 21956 from NYP to Baltimore MD on track 3. Shortly after leaving Baltimore, the portable ride quality meter stopped operating due to low battery voltage. The power supply in the portable ride meter was modified for more efficient charging after this incident. Metroliner car S/N 21956 was not available for data collection from WAS to NYP after the modifications to the ride meter were completed. Car S/N 44914 was used to collect data on track 2 from WAS to NYP and on track 3 from NYP to WAS on December 22, 1993. Limited data from car S/N 21956 is included in this report.

2.4 TEST EQUIPMENT AND PROCEDURE

2.4.1 Test Equipment Overview

Two different sets of test equipment were used during the test program. To maintain consistency, the same accelerometers were used in both sets of test equipment. Details of the design and calibration of the initial test equipment and the final portable ride quality system are given below.

2.4.1.1 Initial Ride Quality Test Equipment

A non-portable ride quality data acquisition package was assembled to collect data while the final portable ride quality system was under development.

Acceleration data was obtained from two Schaevitz linear accelerometers, one oriented in the vertical axis and one oriented in the lateral axis. The accelerometers were attached to a 7/8 inch thick, 12 inch square steel plate.; DC excitation was provided by an ENSCO-built power supply, plugged to the 110 volt AC train hotel power. An additional Schaevitz accelerometer was oriented in the longitudinal direction for the initial tests using the DAT recorder.

Acceleration data was recorded on a four channel, TEAC RD-120T DAT PCM recorder, using a $\pm 5V$ setting. Acceleration signals were recorded directly as voltages, with no external filtering; the TEAC unit contained anti-aliasing filters. Output signals from the recorder, on playback, were at a $\pm 2V$ level. During the post-processing phase, the data was played back from the TEAC recorder through 100 Hz analog low pass filters and digitally recorded using a Computer Boards PPIOIA8 A/D converter on the $\pm 5V$ range. NOTEBOOK LE software was used to control the data acquisition and storage from the A/D converter. Data was recorded from the vertical, lateral, and longitudinal accelerometer channels at 200 samples per second. Data files in ASCII integer format (counts) were generated for each of the test zones for both the X2000 and the ICE.

Files were made as raw voltage with no corrections for gain or offset in the transfer to disk.

The playback configuration is shown below:

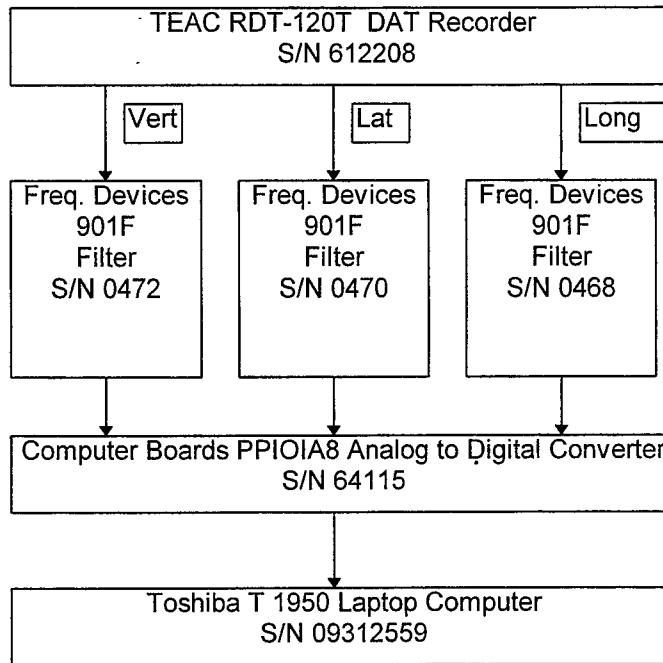

Figure 2.1 Playback configuration

2.4.1.2 Calibration of Initial Ride Quality Test Equipment

Accelerometers were calibrated prior to the testing using one-g inversion (turnover test) to determine the voltage output and gain of each accelerometer. Filters were not used during data recording. During data playback the Analog Devices adjustable low pass filters were set to 100 Hz, unity gain, and zero offset prior to playback. A recorded one-g turnover test was used to determine the correct gain for the lateral, vertical, and longitudinal accelerometers, including the effect of recording at ± 5 volts and playback at ± 2 volts. Acceleration readings on level tangent track were used to set the offset values for lateral and vertical channels to result in RMS values of 0. g lateral and 1.0 g vertical. These offset values corrected for any errors in placement of the accelerometers in the vehicles as well as any small voltage offsets on the particular channels of the PPIOIA8 A/D board.

2.4.1.3 Portable Ride Quality Test Equipment

The portable ride quality system developed for this test was designated as the ENSCO Model 200 Ride Quality Meter. The portable ride quality system consisted of the same lateral and vertical accelerometers used in the initial tests mounted in a small box that also contained batteries, power supply, a signal conditioning card, and an analog to digital converter. The data was interfaced to the parallel port of the Toshiba T1950 laptop computer via a ribbon cable. Notebook LE software was used to control the A/D board, to obtain the digital voltage readings, to store the data in ASCII format on disk, and to display the raw voltage as a time history on the computer's LCD screen. The time history plot on the screen was near real-time display, lagging by about 2-4 seconds. Data was recorded from both the vertical and lateral accelerometers at 200 samples per second. The ride quality accelerometer package operated from its internal rechargeable batteries, and the Toshiba laptop computer operated from normal rechargeable batteries. Battery life of the accelerometer package was sufficient to operate for a test run from Washington to New York and a return run from New York to Washington without requiring recharging. The laptop required one battery change after approximately 2.5 hours of operation. Two laptop batteries were used; at least one laptop battery had to be recharged in New York prior to beginning a return test from NYP to WAS. The unit is shown in Figure 2.2.

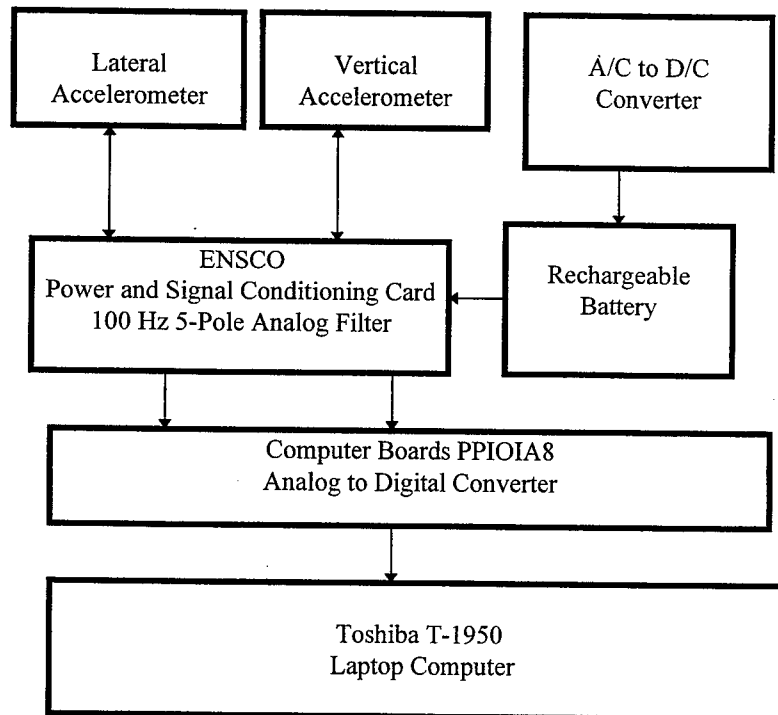

Figure 2.2 Portable Ride Quality System

2.4.1.4 Calibration of Portable Ride Quality Measurement System

The portable ride quality accelerometer package contained gain and offset potentiometers accessible by removing the cover. Gain settings on the package were adjusted to give ± 4.6 - 4.8V output from each axis for ± 1.0 g acceleration. Before and after each data run, turnover tests were recorded at 50 samples per second for the two accelerometers and the power supply voltage from the ride quality package. During data reduction, the results of these one-g turnover tests were used to confirm the accelerometer gains. Data from tangent track was used to determine offsets for lateral and vertical to achieve RMS values of 0. g lateral and 1.0 g vertical. These offsets accounted for a known 1.5° difference between the accelerometer mounts and the top of the case, and for any voltage offsets internal to the PPIO IA8 A/D board for each channel.

2.4.2 Test Logs

Test logs were made of each trip including train type, orientation, date, track number, time, mileposts, speed, location of instrumentation, S/N's of train consist, and notes of specific acceleration events such as jolts, interlockings, etc. To reduce the workload during the tests, test log forms were prepared in advance with milepost numbers, station and interlocking names, and locations of current ride quality exceptions already printed. Speed data was obtained by two methods. On the October 1 test of the ICE coach, milepost passing times were recorded and used to calculate the train speed at locations of interest. More accurate and more complete speed data for coach tests was obtained by keeping a separate log in either the locomotive or trailing cab noting speed and time at mileposts and interlockings. Speed data was recorded directly on the main log form during locomotive and cab units tests. Verbal information was recorded on the audio track of the DAT recorder and also used during data reduction. Attempts to obtain speed and position information by viewing mileposts from the coach cars were marginal. Lighting conditions and high speed made milepost spotting particularly difficult on track 3 in the late afternoon to early evening. After dark, mileposts were difficult to read from the leading locomotive if the engineer used the dim headlight setting when meeting other trains.

2.4.3 Speed Profiles

Normal operating speed as prescribed by Amtrak timetables for each of the trains were used for each trip. No specific profiles were required for these tests. The actual speeds obtained during the testing were a result of specific maintenance slow orders, ride quality slow orders, and normal speed restrictions from the signal system. Figures 2.3 - 2.6 show the actual speeds attained during testing.

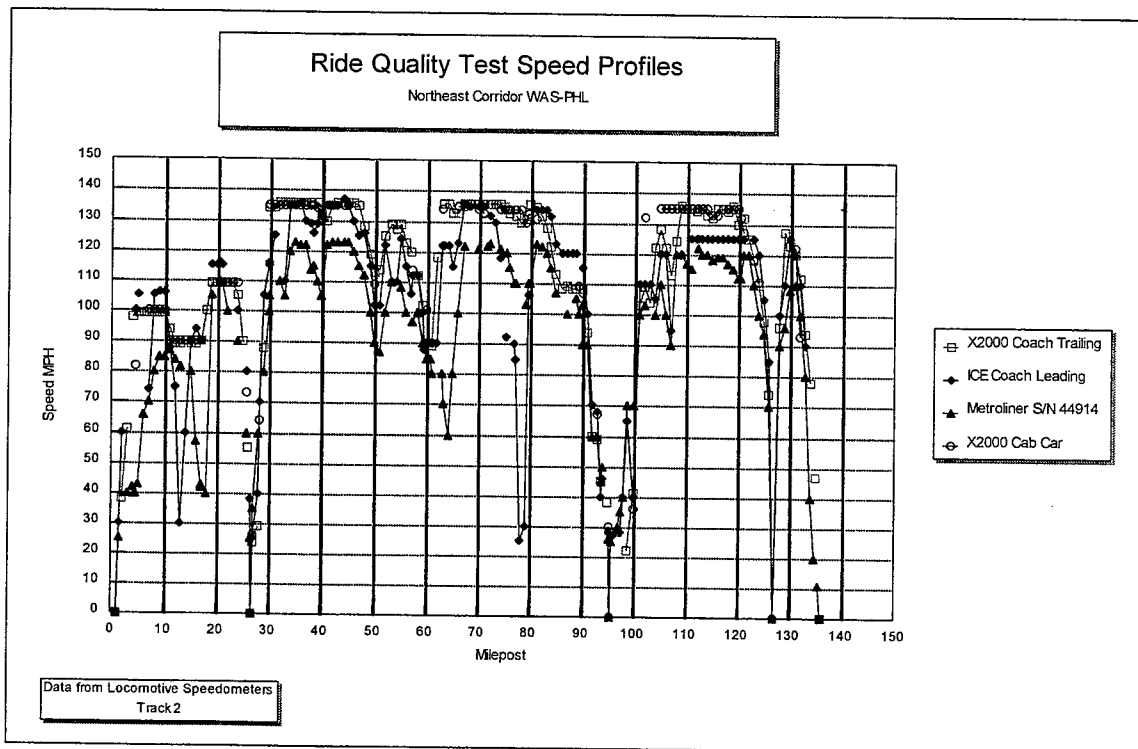

Figure 2.3 Speed Profiles Track 2 Between Washington and Philadelphia
Note: Philadelphia = Milepost 0, Washington = Milepost 136

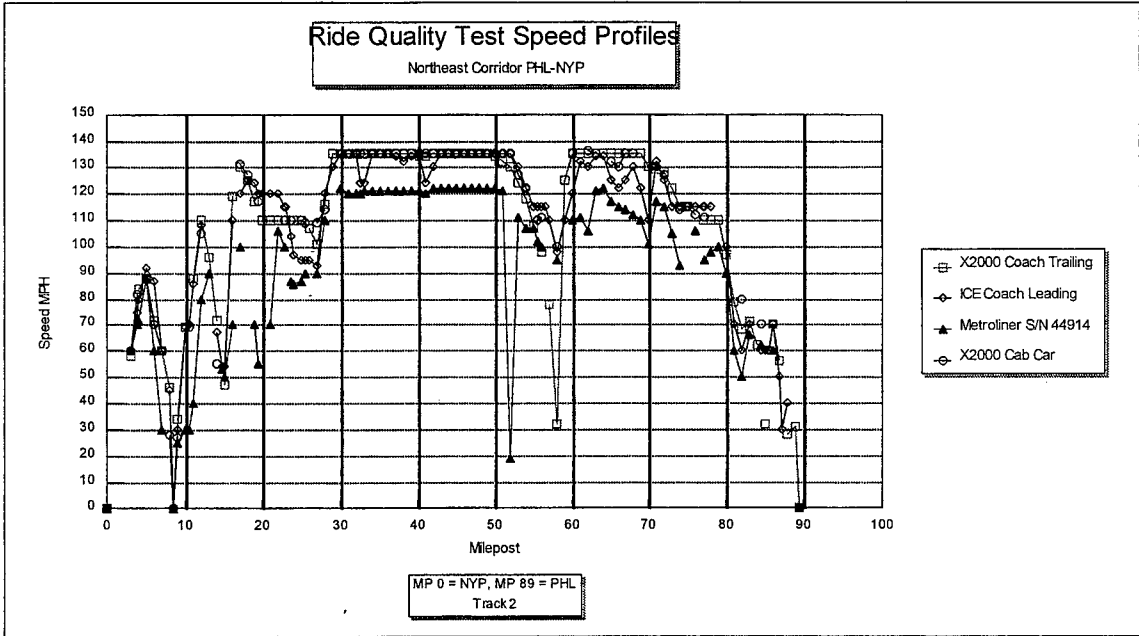

Figure 2.4 Speed Profiles Track 2 Between Philadelphia and New York
Note: Philadelphia = Milepost 89, New York = Milepost 0

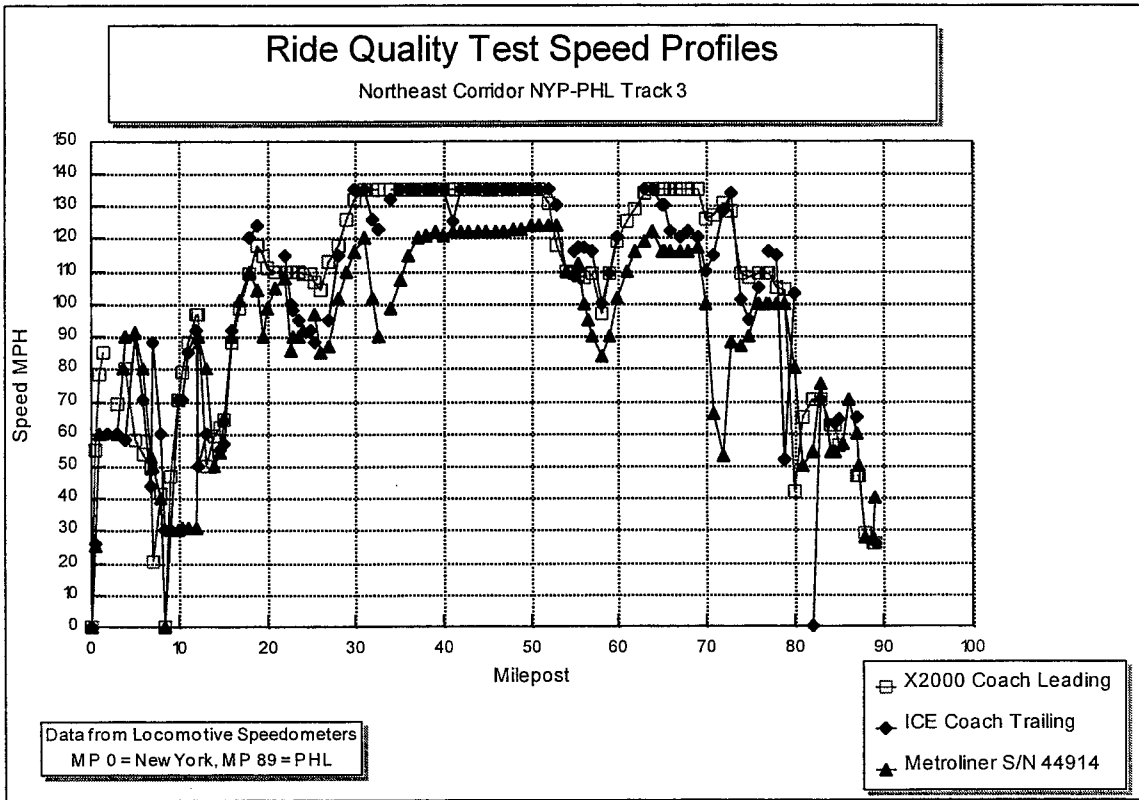

Figure 2.5 Speed Profiles Track 3 Between New York and Philadelphia

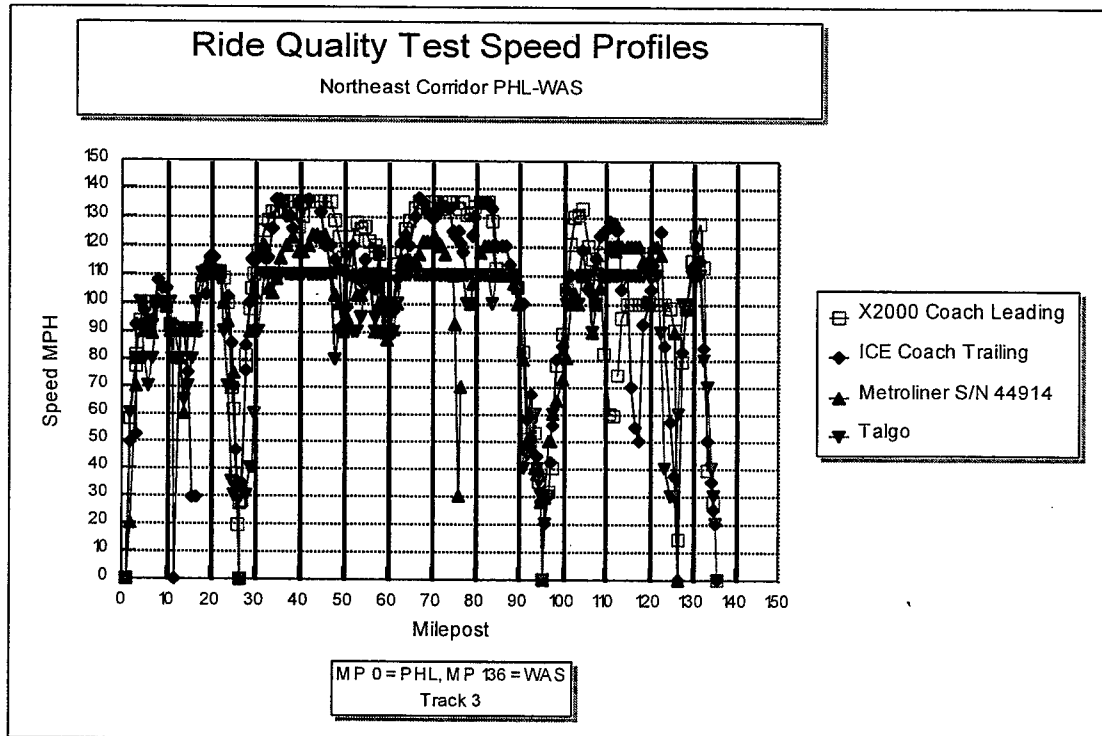

Figure 2.6 Speed Profiles Track 3 Between Philadelphia and Washington

2.4.4 Test Safety

All tests were done during operation at approved speeds and cant deficiencies. The main aspect of test safety was assuring that the instrumentation did not cause a hazard to normal operation of the trains including passenger movement in the coach car under test. Cables, power wires and other leads were taped down to floors or walls to avoid entanglement of passengers. Safety goggles were worn in the locomotive cabs and coordination with Amtrak insured that the four person limit in locomotive cabs was not exceeded.

3. ANALYSIS

The acceleration data was studied both in the time and frequency domains. The time domain analysis concentrated on the responses of the vehicles to discrete track features including interlockings and points at which carbody accelerations exceeded the Amtrak peak-to-peak limits for ride quality exceptions. The frequency domain analysis was used on steady-state data over tangent track and through curves.

An analytical computer program, TFPLLOT, was developed for this task. The program read the ASCII data files recorded on disk by the Notebook LE software, applied offset corrections and accelerometer calibrations to convert the data into acceleration values in g's. The time associated with each data point was calculated using the data rate stored as part of the raw data file. Once the data was in the engineering unit form, time histories could be generated or frequency analyses could be performed on any selected channel. The average and RMS values of acceleration in each axis were calculated from the engineering unit data. An example time history plot is shown in Figure 3.1 below.

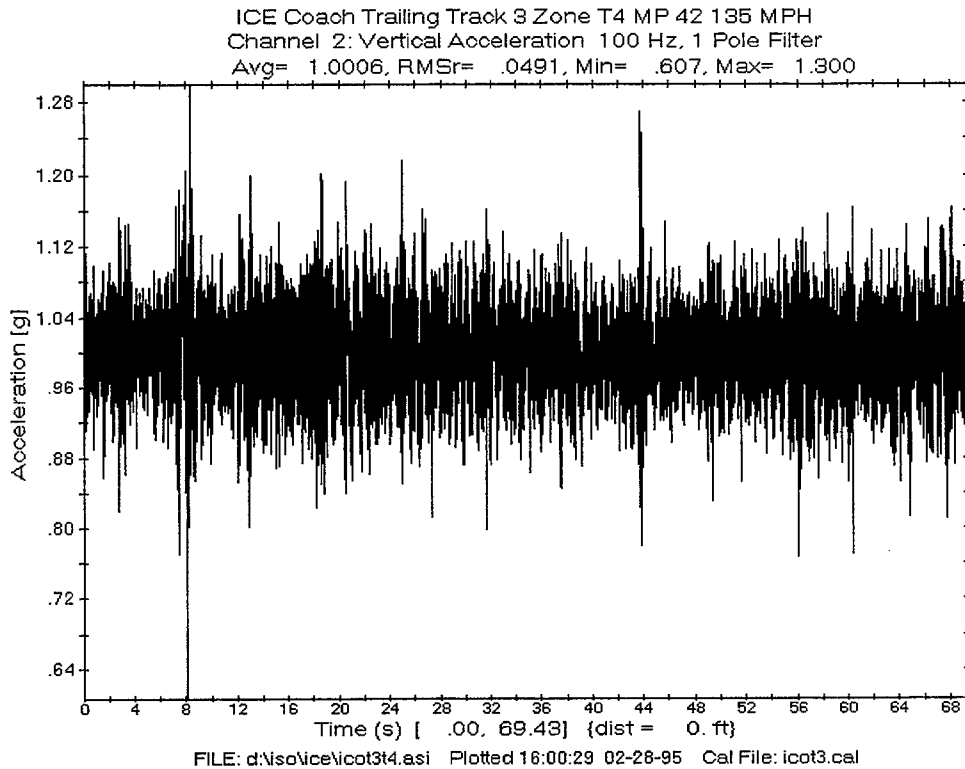

Figure 3.1 Example Time History Plot from TFPLLOT

Frequency analysis used either a Fourier integral or a fast Fourier transform method as selected by the user. The resulting spectrum could be displayed in two ways, first a narrow band presentation shown in Figure 3.2.

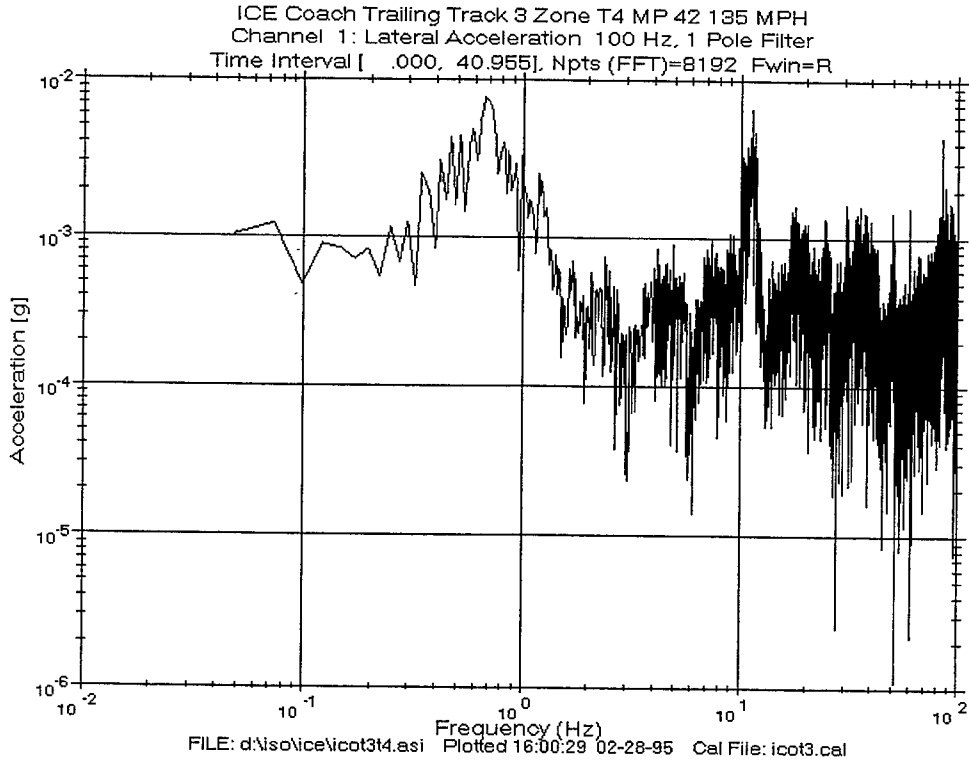

Figure 3.2 Narrowband Frequency Plot

The second display was a 1/3 octave band presentation from .5 to 80 Hz, plotted as the RMS average over each band at the center frequency of the band as shown in Figure 3.3. The ISO 2631 "Reduced Comfort Exposure Levels", for the appropriate axis are also displayed on the plot. The center frequency of the 1/3 octave band resulting in the shortest exposure time, referred to as the limiting frequency, is indicated at the lower left of the display. All graphs were displayed on the computer screen and could then be printed as a hard copy if desired.

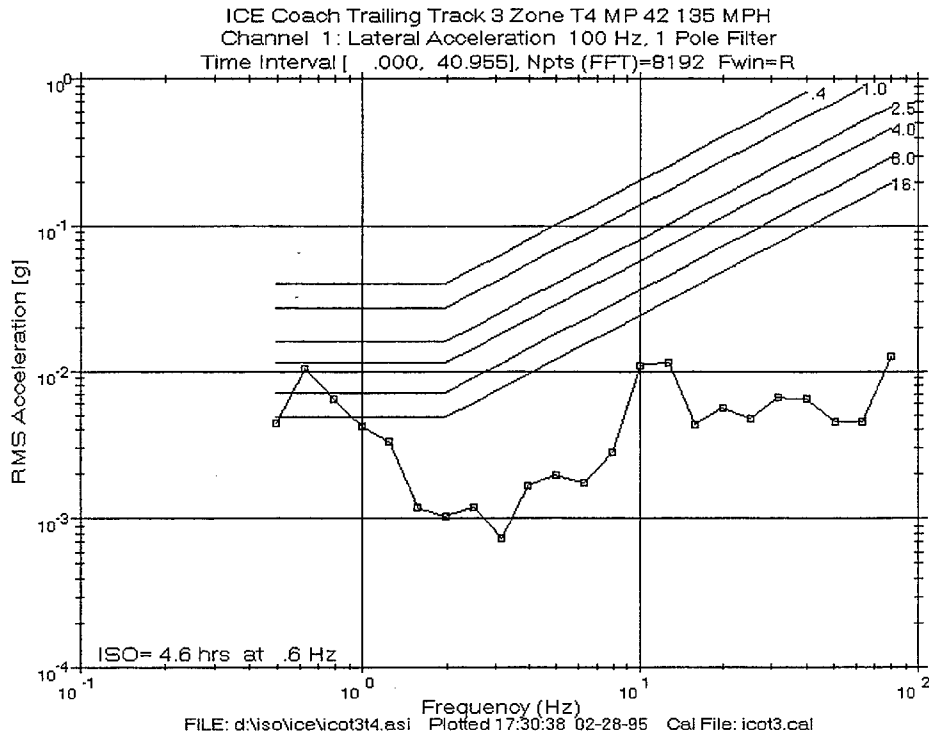

Figure 3.3 1/3 Octave band Plot

3.1 FREQUENCY DOMAIN ANALYSIS

Data from the selected test sections was analyzed using the TFPLOT software developed for this project. Before performing a frequency analysis, the time history plots were examined to identify specific signatures which ensured that frequency data from each vehicle was taken over the same physical piece of track. ISO Standard 2631 "Guide for the evaluation of human exposure to whole-body vibration" provided a means of comparing the ride quality of the different vehicles. The methods presented in this Standard account for the varying human sensitivity to vibration at different frequencies and in different axes. The standard called for averaging the vibration over 1/3 octave bands from 1 to 80 Hz. The 1/3 octave band data can then be compared to limits established for three levels:

- Reduced comfort
- Fatigue-decreased efficiency
- Exposure limit

The reduced comfort level was used to compare the vehicles. The standard provided a value for RMS vibration in each 1/3 octave band for lateral and vertical vibration corresponding to the number of hours a human could be exposed to that vibration

before experiencing reduced comfort. This method allowed comparison of vehicles with different characteristic frequencies of vibration. The ISO 2631 limits were linearly extrapolated below the 1 Hz frequency to evaluate vibrations or motion in this region. This method was conservative since the technical literature has proposed that ISO 2631 be extended into this region at levels less than those obtained by the linear extrapolation. The results of the ISO 2631 analysis are presented in hours of exposure to reach the reduced comfort limit.

Each frequency plot resulted in a spectrum of vibration processed and compared to the ISO 2631 Reduced Comfort Limits. The software automatically determined the frequency at which the minimum time for the Reduced Comfort Level of vibration was reached. Summary plots of these times and their associated frequencies were made for the curved and tangent test sections. Time periods for the curved track sections were selected to encompass the entry and exit spirals as well as the main body of each curve. Time periods for the tangent test zone were selected to show vibrations at several locations while running at the maximum allowable speed.

3.1.1 Tangent Track Frequency Analysis

Lateral Vibration

Figures 3.4 and 3.5 summarize the analysis of lateral vibration on tangent track. All of the coaches tested had ISO 2631 reduced comfort limits exceeding 4 hours in the lateral direction. The Metroliner ranged from 4-7 hours at 125 mph. The limiting time for the Metroliner increased rapidly for speeds below 122 mph. At lower speeds the Metroliner coach achieved lateral time limits of greater than 18 hours. The ICE data ranged from 5-13 hours at 135 mph. The ICE data had more scatter than any of the other vehicles. The X2000 achieved the longest limiting times in the lateral axis with greater than 7.5 hours at all speeds. At the maximum speed of 135 mph, the X2000 coach in the leading position had a limiting time of 15.5 hours.

The frequencies associated with the limiting exposure times varied little between the vehicles and for each vehicle did not appear to be a function of the speed. All vehicles had critical frequencies between 0.5 and 2 Hz. The ICE frequencies were the lowest, between 0.5 and 0.6 Hz. The X2000 had critical frequencies in the 1.6 to 2 Hz range. The Metroliner showed a slight decrease in critical frequency with increasing speed. At 125 mph the Metroliner had critical frequencies of 1.0-1.2 Hz.

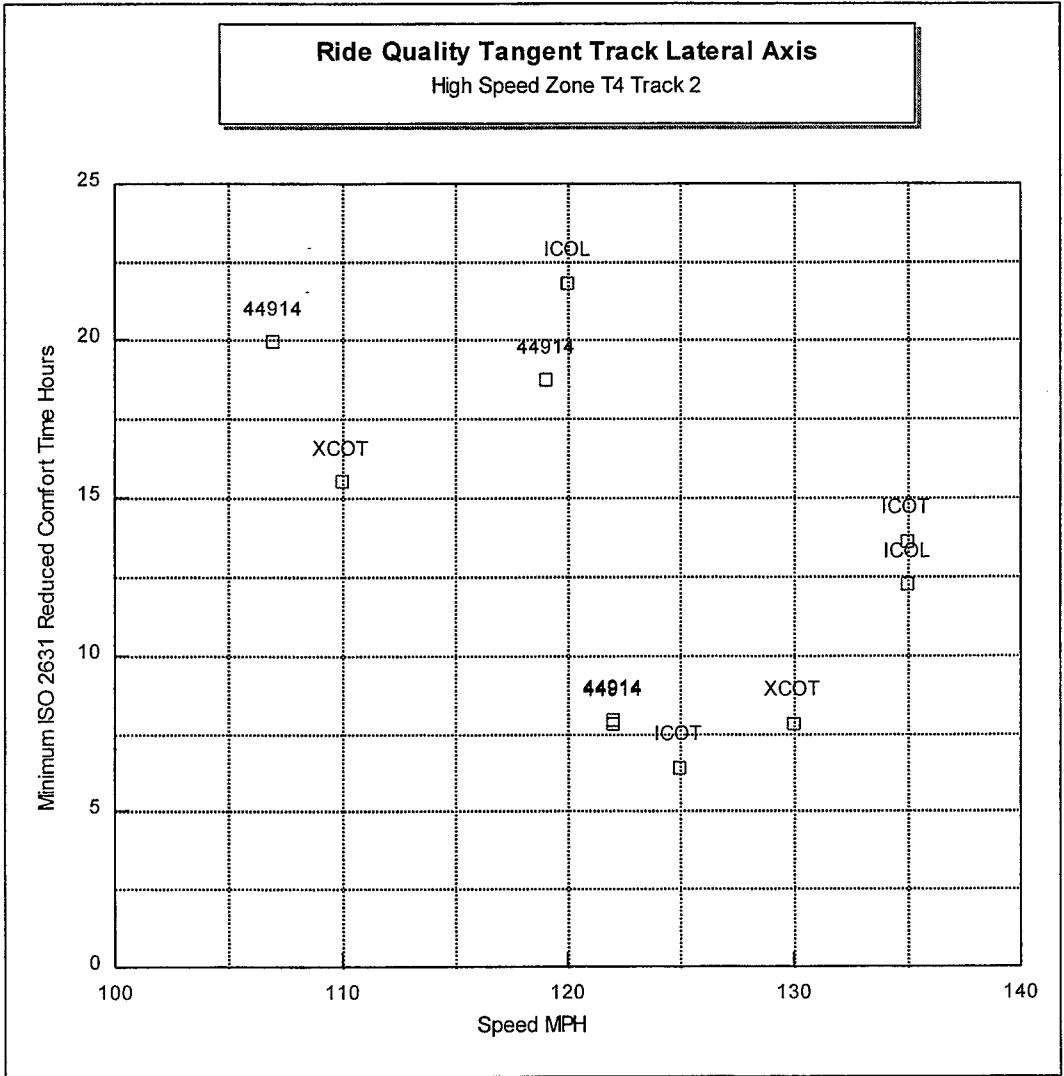

Figure 3.4 ISO Reduced Comfort Times Tangent Test Zone Track 2

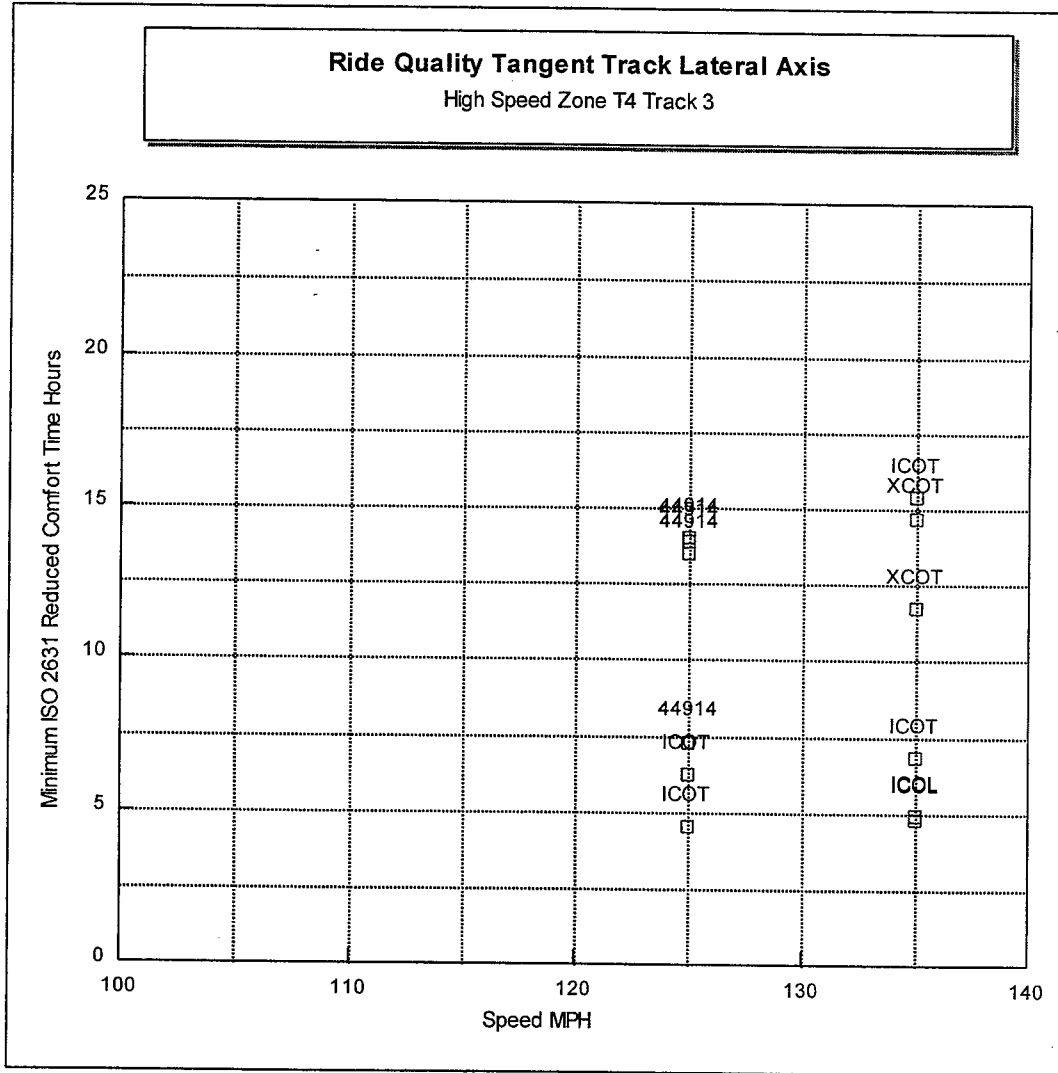

Figure 3.5 ISO Reduced Comfort Times Tangent Test Zone Track 3

Vertical Vibration

Figures 3.6 and 3.7 summarize the analysis of vertical vibration on tangent track.

The limiting exposure times for the reduced comfort level in the vertical direction had wider variation than in the lateral direction. The minimum time at 135 mph was approximately 7 hours while the maximum time was approximately 13 hours. The ICE achieved limiting times of 6.6 to 11.7 hours at 135 mph. The Metroliner limiting times at 125 mph ranged from 6.4 to 12.7 hours. The X2000 had the longest exposure times at speeds between 130-135 mph, ranging from 13 to 13.5 hours.

There was wider variation in the critical frequencies for vertical vibration than for lateral vibrations. The ICE frequencies were lower than the other two coaches at 1.6 to 8 Hz.

The X2000 had a critical frequency of approximately 16 Hz at all speeds. The Metroliner had a critical frequency of 20 Hz at all speeds.

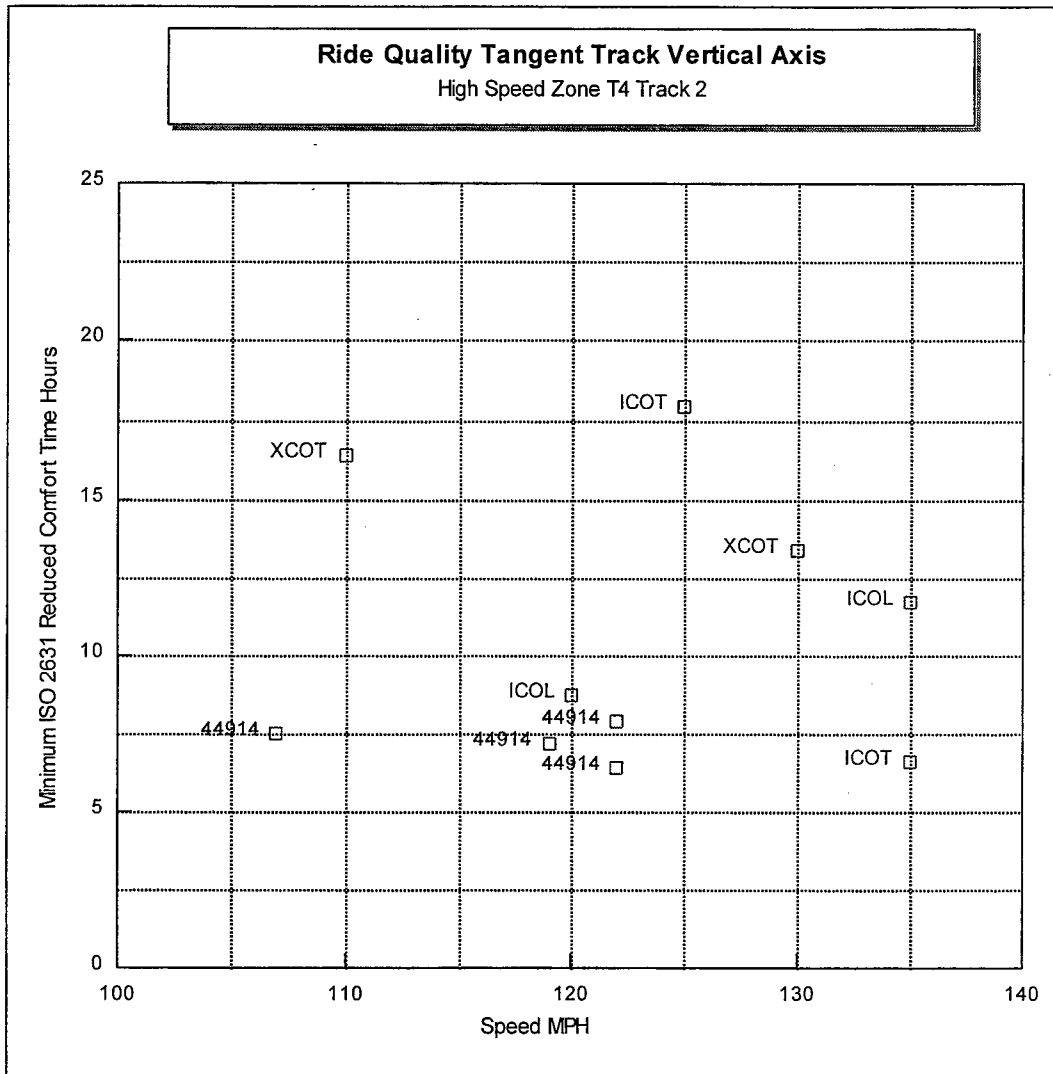

Figure 3.6 Vertical Vibration Tangent Test Zone Track 2

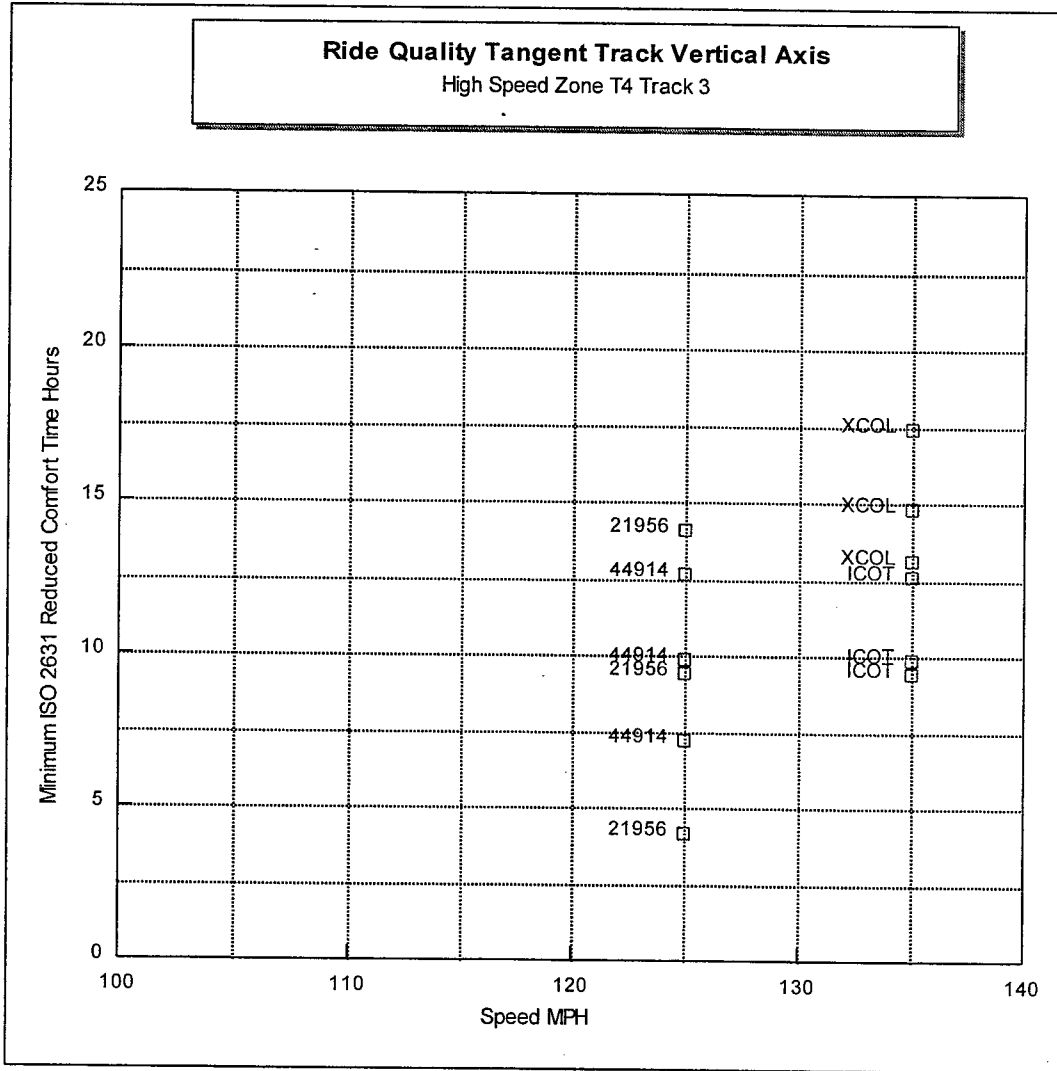

Figure 3.7 Vertical Vibration Tangent Test Zone Track 3

RMS Analysis

The RMS values over the entire frequency band of 0-100 Hz were also compared for the high speed test section. The RMS value computed over all frequencies from 0.1 to 100 Hz, was compared for the same time periods as the data points used in the ISO exposure time analysis. Figure 3.8 indicates that the X2000 had the lowest overall vibration in both the lateral and vertical axes at 135 mph. The ICE had RMS vibration levels at 135 mph which were similar to the vibration of the Metroliner car at its slower top speed of 125 mph. The lateral and vertical RMS vibration levels of the X2000 were similar. The ICE and the Metroliner had higher RMS vibration levels in the lateral axis than in the vertical axis. Figures 3.8 - 3.9 contain the results of the RMS vibration analysis of the tangent track test zone T4.

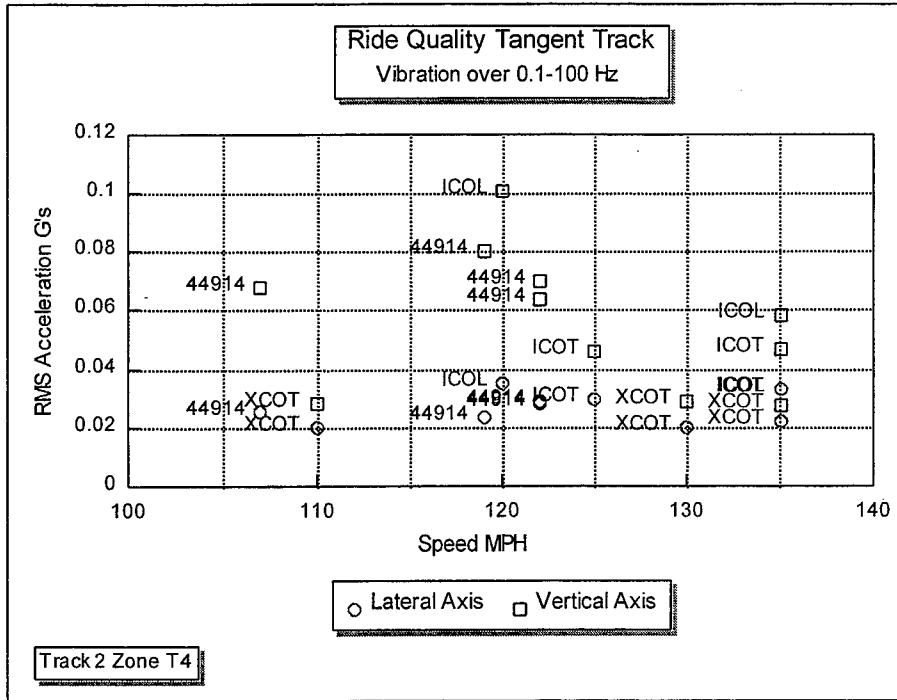

Figure 3.8 RMS Vibration Tangent Test Zone Track 2

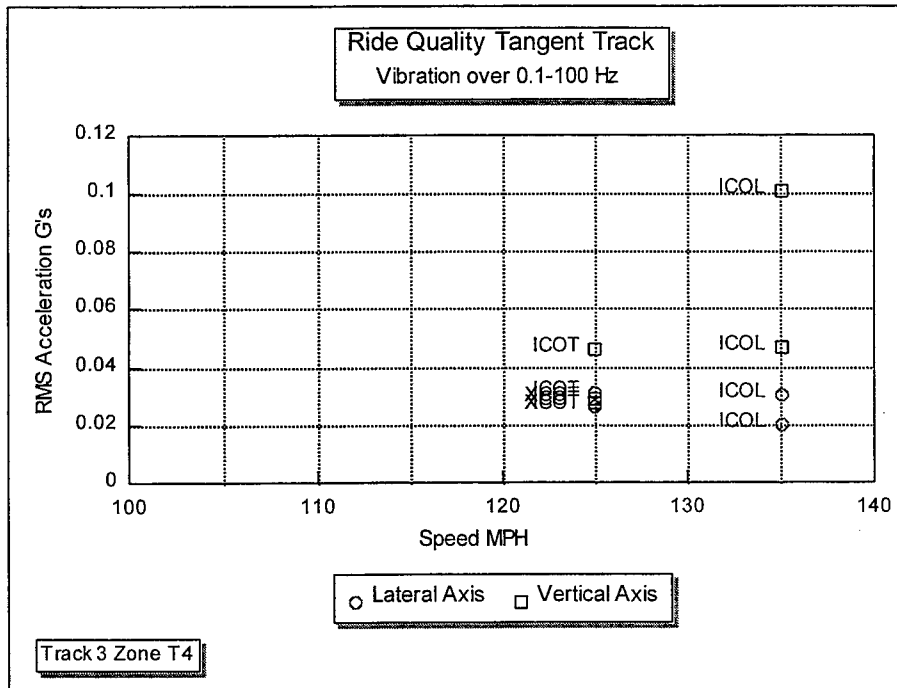

Figure 3.9 RMS Vibration Tangent Test Zone Track 3

3.1.2 Curving Track Frequency Analysis

The time history data for each vehicle was examined for the curve test zones C4, C5, and C6, to determine the entry and exit times for the specific curves in each zone. These times were then used as the integration limits for the Fourier integral frequency analysis for each curve. Table 3.1 summarizes the curves and their geometry.

Table 3.1 Test Curves on Northeast Corridor

Track No.	Curve No.	Curvature Deg, Min	Superelevation In
2	255	0°, 14'	0
2	256	0°, 20'	0.75
2	275	0°, 19'	2.0
2	276	0° 32'	3.625
2	290	1°, 20'	5.5
2	291	1°,45'	5.75
2	292	0°,48'	4.25
3	255	0°, 0'	0
3	256	0°, 33'	1.5
3	275	0°, 20'	2.125
3	276	0°, 31'	3.5
3	290	1°, 30'	6.0
3	291	1°,36'	6.00
3	292	1°,15'	3.5

Figures 3.10 - 3.11 summarize the average ride quality on curving track for the selected curves .

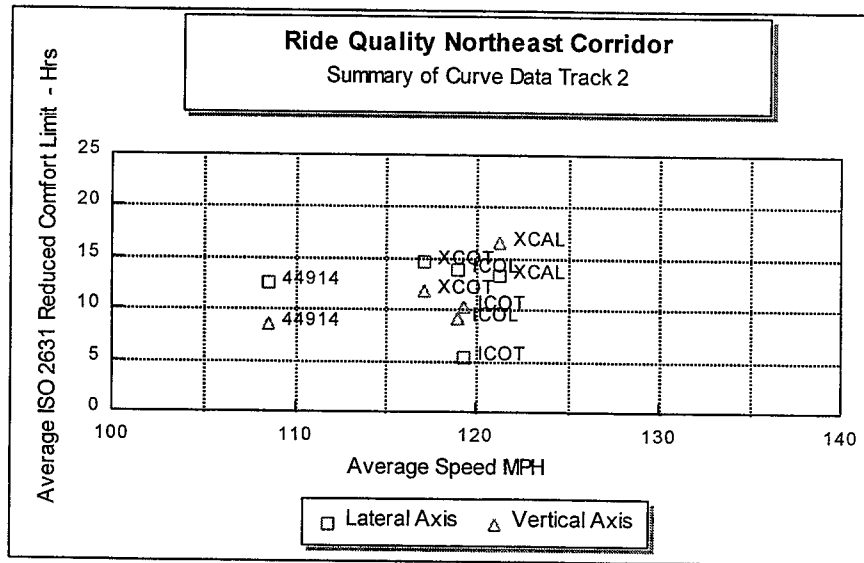

Figure 3.10 Curve ISO Data Track 2

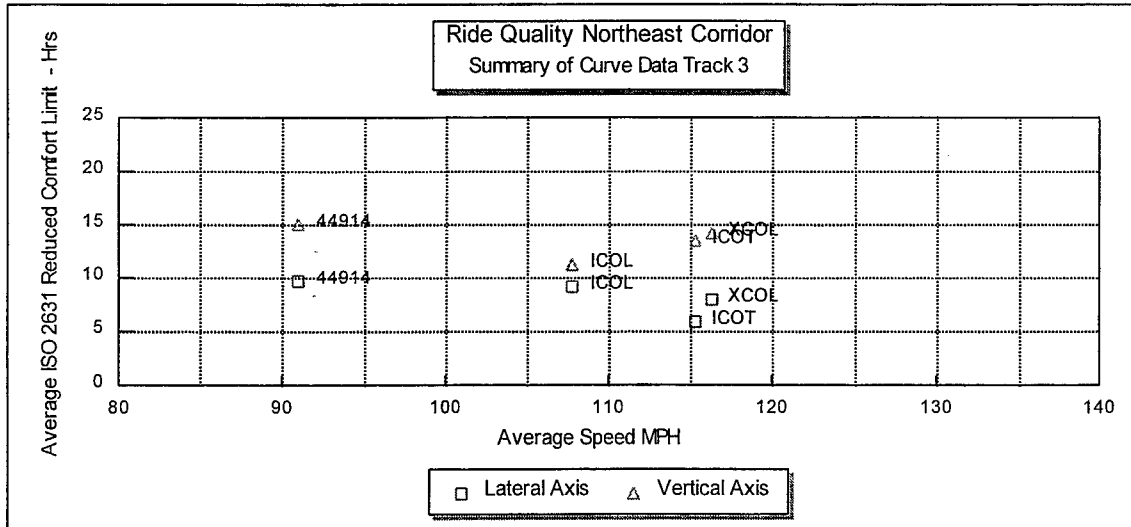

Figure 3.11 Curve ISO Data Track 3

Plots were made of the ISO frequency analysis data from all of the vehicles for each curve on track 2 and track 3. The vehicle speed and the curvature and superelevation of the curve were used to calculate the test cant deficiency. The limiting times for each axis were calculated and plotted for each vehicle. Curve 256 proved to be a "rough" curve with all vehicles having the shortest exposure times in that curve. Curves 290 and 292 were the "smoothest" curves with all vehicles achieving their longest exposure times on them.

X2000 Coach Trailing/Track 2

The vertical axis was the most limiting in terms of reduced comfort exposure time. The shortest exposure time was approximately 8 hours on curve 256 at a cant deficiency of 2 inches. All of the other curves had exposure times above 10 hours. There was no strong variance of vertical limit time with cant deficiency. The shortest lateral exposure time of 8 hours also occurred at curve 256. There was a larger variation in lateral exposure times with all other curves ranging from 11 to 19 hours to reach the reduced comfort limit. Figure 3.12 summarizes the curving ride quality of the X2000 on track 2.

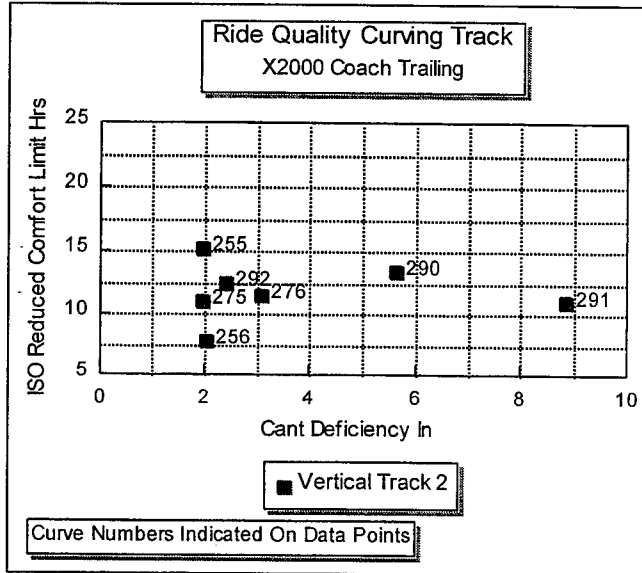

Figure 3.12 Curve ISO Data X2000 Track 2 Vertical Axis

X2000 Coach Leading/Track 3

On track 3 the lateral axis had the shortest time for the reduced comfort exposure level. Curve 256 resulted in a 4 hour exposure time at 3.1 inches of cant deficiency. All other curves had lateral time limits of 6-11 hours. There was a trend toward reduced lateral exposure time with increasing cant deficiency. In the vertical axis, curves 275 and 276 yielded exposure limits of 7.5 to 8 hours. The other curves had time limits from 15 to 20 hours. With the exception of curves 275 and 276, there was a similar trend toward reduced exposure time with increasing cant deficiency in the vertical axis. Figures 3.13 - 3.14 summarize the curving ride quality of the X2000 on track 3.

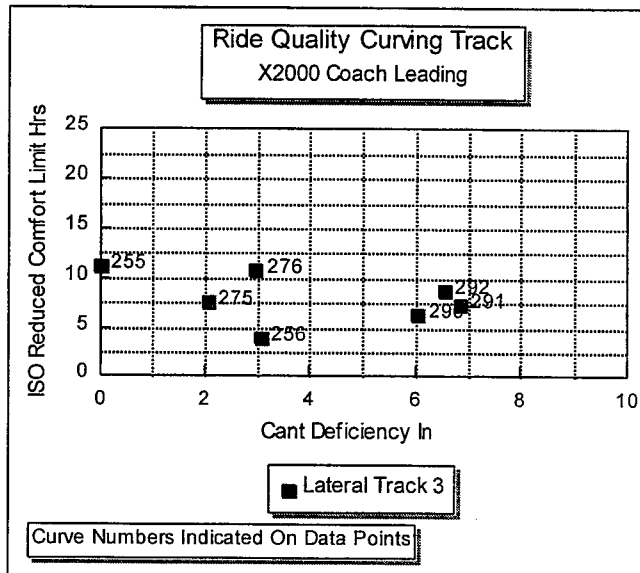

Figure 3.13 Curve ISO Data X2000 Track 3 Lateral Axis

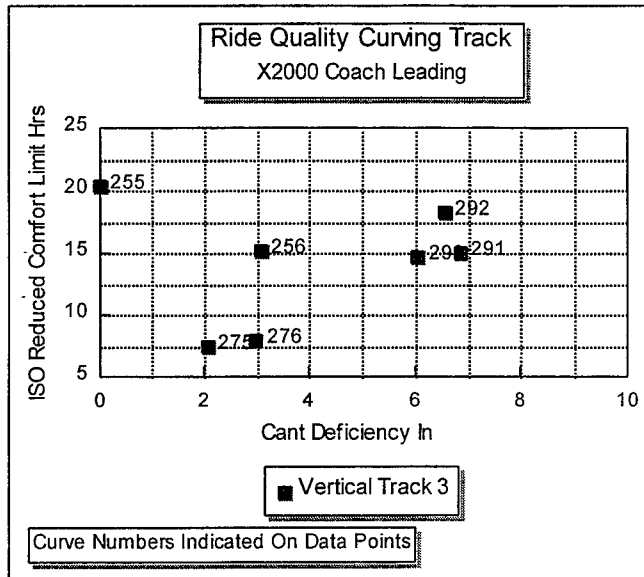

Figure 3.14 Curve ISO Data X2000 Track 3 Vertical Axis

ICE Coach Trailing/Track 2

Vibrations in the lateral axis resulted in the shortest exposure times for the ISO Reduced Comfort level for the ICE coach in this configuration. Curve 275 resulted in an exposure limit of 2.5 hours at a 2 inch cant deficiency. Curves 255 and 256 had 3 hour exposure limit times. Curves 290 and 291 had longer exposure times ranging from 6-13 hours. There was a trend of increasing exposure time with increasing cant deficiency in the lateral axis. The vertical axis had a 5 hour limiting time for curve 255 at a 2.2 inch cant deficiency. Curve 256 and 276 had slightly greater exposure times of 6-7.5 hours. Again curves 290 and 291 had the longest exposure times of 15-18 hours. The vertical axis also showed a trend toward increased exposure times at increasing cant deficiencies. Figures 3.15 - 3.16 summarize the ICE curving ride quality on track 2.

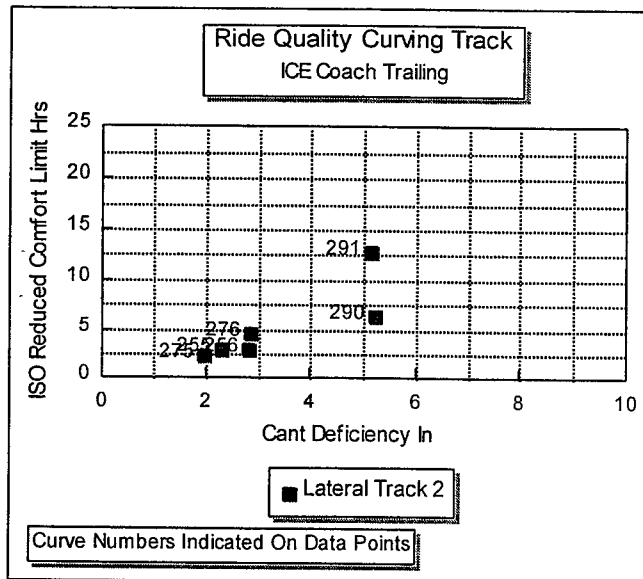

Figure 3.15 Curve ISO Data ICE Track 2 Lateral Axis

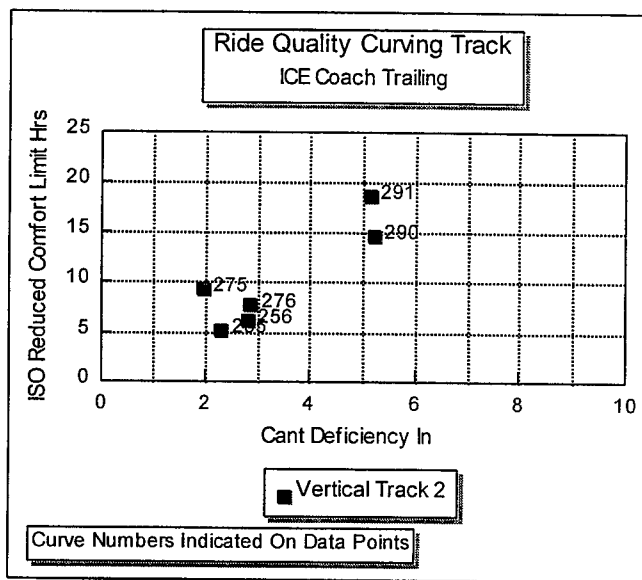

Figure 3.16 Curve ISO Data ICE Track 2 Vertical Axis

ICE Coach Leading/Track 2

The minimum exposure time of 4 hours in the lateral axis occurred at curve 275 at a cant deficiency of 2 inches. Curve 256 also had a minimum exposure time of just over 5 hours in the lateral axis. All other curves had over 12.5 hours of exposure time for the reduced comfort axis. In the vertical axis, curve 292 had the lowest exposure time of 7 hours. The other curves ranged from 7.5 to 12.5 hours in exposure time. Figures 3.17 - 3.18 summarize the ICE coach leading ride quality in curves on track 2.

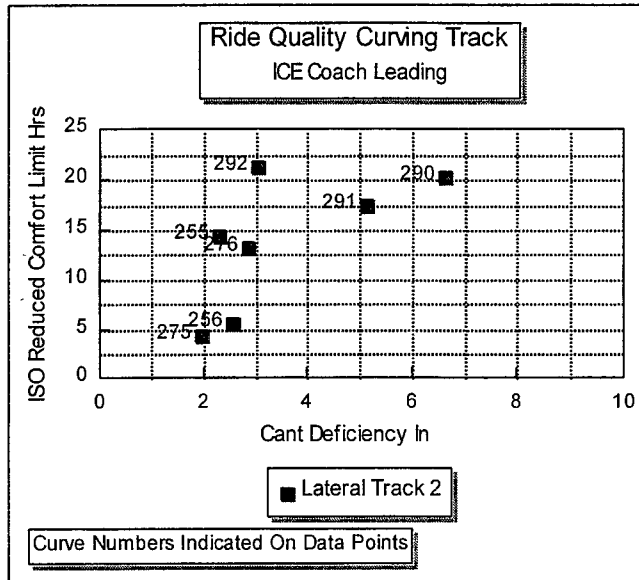

Figure 3.17 Curve ISO Data ICE Track 2 Lateral Axis Coach Leading

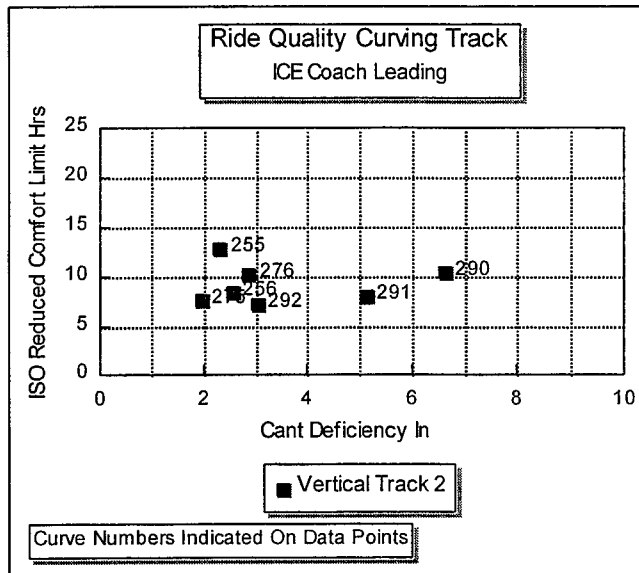

Figure 3.18 Curve ISO Data ICE Track 2 Vertical Axis Coach Leading

ICE Coach Trailing/Track 3

The lowest exposure time occurred in the lateral axis on curve 256, which resulted in a 2.2 hour exposure limit. All other curves had limits of 4.8-11 hours. There was a large amount of scatter in the data. No conclusions could be made on the effect of cant deficiency on the lateral axis times. The vertical axis also had the shortest exposure time on curve 256 of 5 hours. The remaining curves ranged from 7 to 23 hours with curves 290, 291, and 292 having the longest time limits. There was a trend toward

increasing vertical exposure time with increasing cant deficiency if curve 256 was neglected. Figures 3.19 - 3.20 summarize the ICE coach training curving ride quality on track 3.

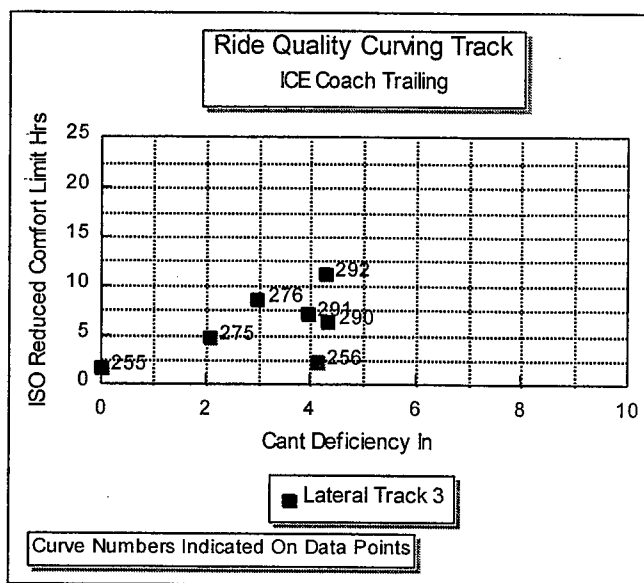

Figure 3.19 Curve ISO Data ICE Coach Trailing Track 3 Lateral Axis

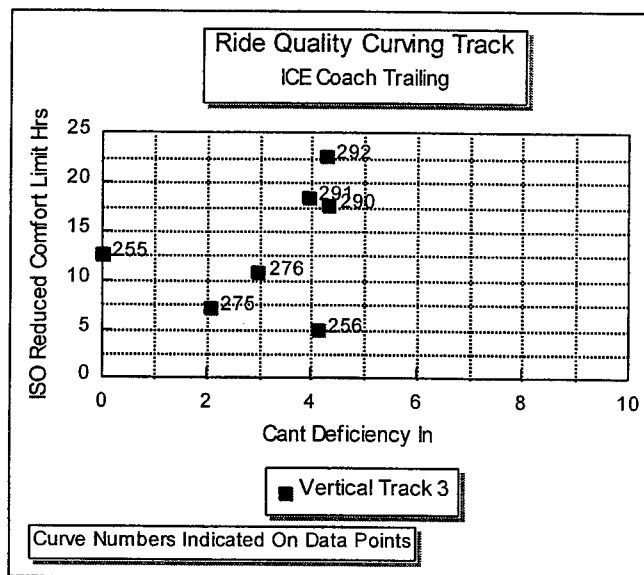

Figure 3.20 Curve ISO Data ICE Coach Trailing Track 3 Vertical Axis

ICE Coach Leading/Track 3

The lowest exposure time occurred in the lateral axis on curve 256 of 4.2 hours at a cant deficiency of 4.2 inches. The remaining curves had exposure times of 6.5-13.5 hours for cant deficiencies of 3.5 to 4.8 inches. There was no trend noted for the effect of increasing cant deficiency due to the small range of cant deficiencies tested. The

shortest vertical exposure time was also from curve 256 of 4.5 hours at 4.2 inches of cant deficiency. There was less variation in the vertical exposure times than the lateral, with the other curves ranging from 6-13 hours at cant deficiencies between 3.5 to 4.5 inches. There was no trend noted for the effect of increasing cant deficiency due to the small range of cant deficiencies tested. Figures 3.21 - 3.22 summarize the curving ride quality of the ICE coach leading on track 3.

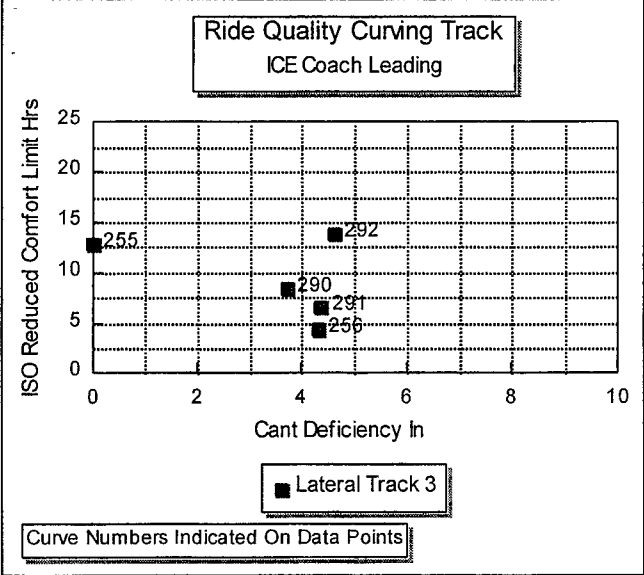

Figure 3.21 Curve ISO Data ICE Coach Leading Track 3 Lateral Axis

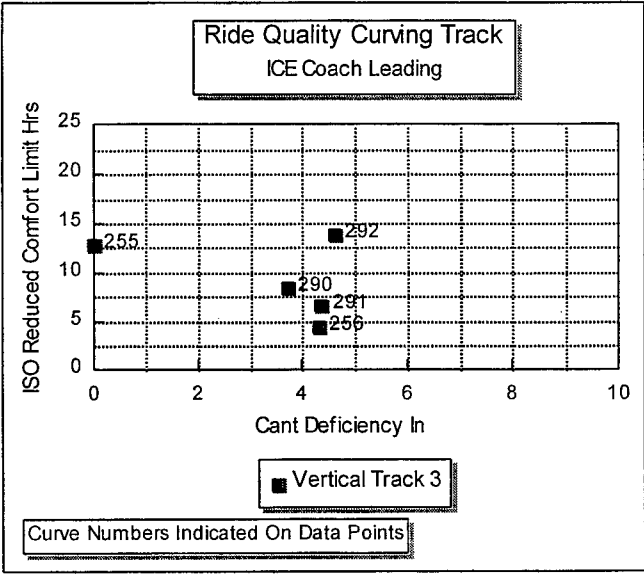

Figure 3.22 Curve ISO Data ICE Coach Leading Track 3 Lateral Axis

Metroliner Coach S/N 44914/Track 2

In the vertical axis, there was a trend for increasing exposure time with increasing cant deficiency. Curve 276 had the shortest exposure time of 5.5 hours. Curve 276 also had the shortest exposure time for the lateral axis of 5 hours. Curves 290 and 291 were considerably better at 18-20 hours exposure time. There was no trend noted for the effect of cant deficiency on vertical exposure time. Figures 3.23 - 3.24 summarize the Metroliner curving ride quality on track 2.

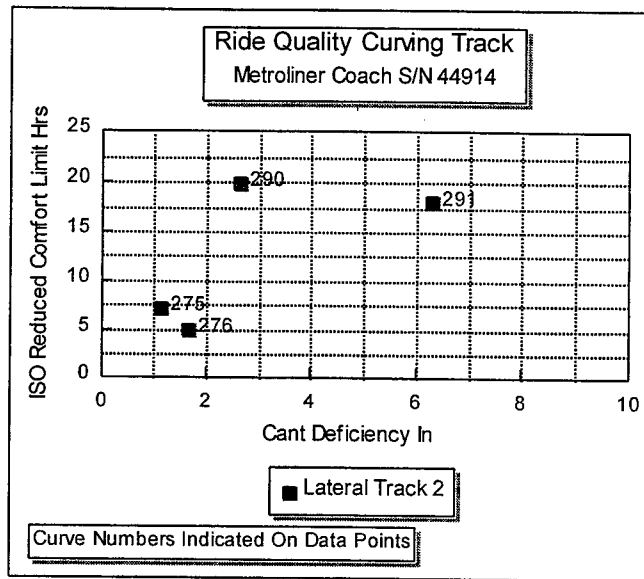

Figure 3.23 Curve ISO Data Metroliner Track 2 Lateral Axis

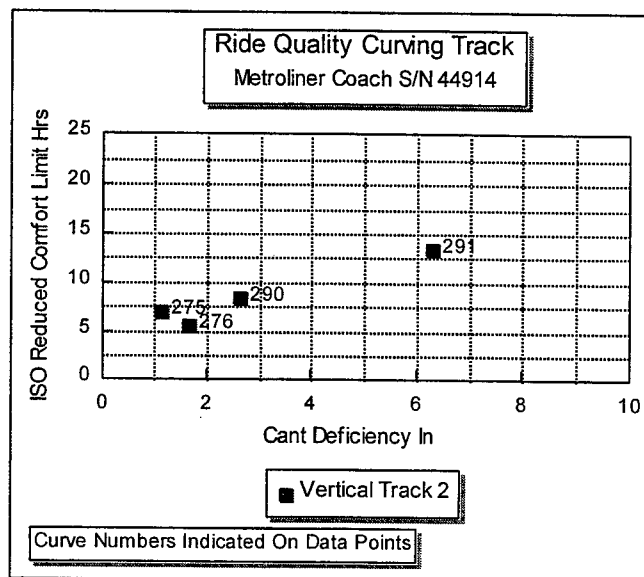

Figure 3.24 Curve ISO Data Metroliner Track 2 Vertical Axis

Metroliner Coach S/N 44914/Track 3

In the vertical axis, the minimum exposure time of 9.5 hours occurred at curve 290. The exposure times for the other curves ranged from 10 to 17.5 hours. There was a slight trend for decreasing exposure time with increasing cant deficiency. In the lateral axis, curve 256 had the shortest exposure time of 4.2 hours. The other curves ranged from 7.5 to 12.5 hours of exposure time. Figures 3.25 - 3.26 summarize the Metroliner curving ride quality on track 3.

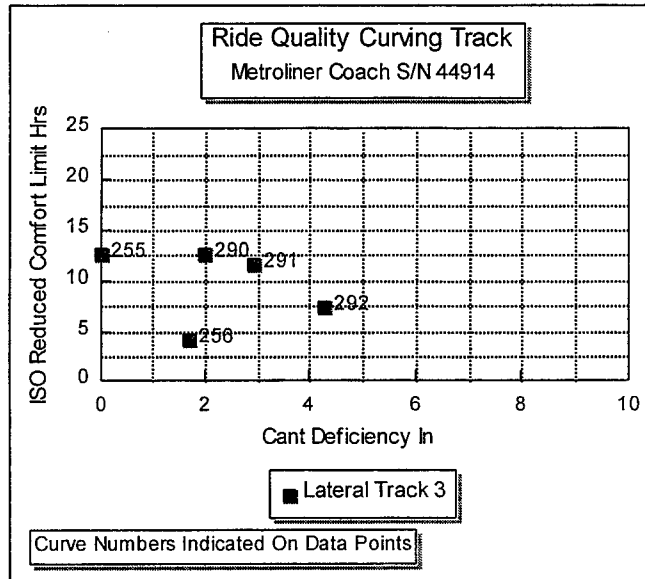

Figure 3.25 Curve ISO Data Metroliner Track 3 Vertical Axis

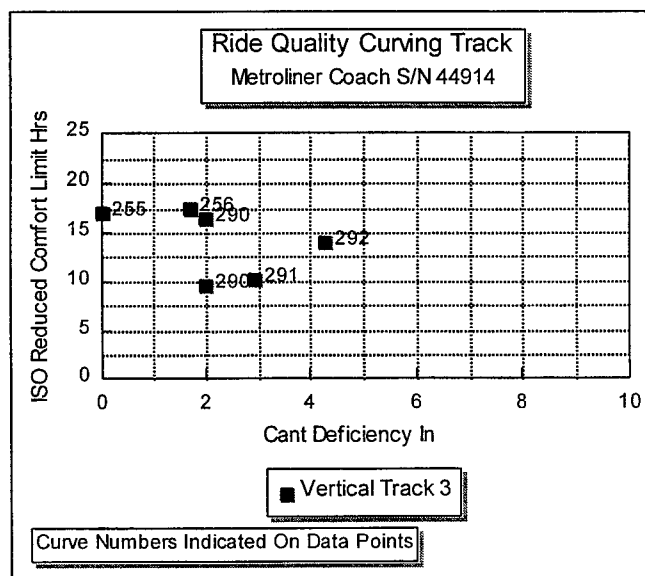

Figure 3.26 Curve ISO Data Metroliner Track 3 Lateral Axis

3.2 TIME DOMAIN ANALYSIS

The vertical response of each vehicle to track disturbances at interlockings, and to points of ride quality exceptions were compared. The TFPLOT program was used to digitally low pass filter the data at 10 Hz. The peak-to-peak acceleration values occurring over a 0.5 second time period were determined using the TFPLLOT software to identify areas of peak vibration. Some of the locations yielded more than one peak with significant vertical response. Summary plots of the vertical responses of the coaches were made for each location. The resulting data was compared to the Amtrak peak to peak criteria as shown in Table 3.2 below:

Table 3.2 Amtrak Limits

Criteria Type	Lateral Limit g's	Vertical Limit g's
Comfort	0.25	0.30
Maintenance	0.40	0.40

3.2.1 Elmora Interlocking

The crossovers in this interlocking produced noticeable vertical accelerations in all of the vehicles tested. The X2000 coach and cab car had the smallest vertical response to the interlocking. Crossing at speeds from 88 to 119 mph, the vertical peak to peak g's were less than 0.2, well below the Amtrak comfort limit. The X2000 showed no variation of response with speed. The ICE coach in the trailing position on track 2 (acceleration measured outboard) exceeded the Amtrak comfort limit, but was just below the Amtrak maintenance limit. The ICE coach in the leading position on track 2 (acceleration measured at centerline) exceeded the Amtrak maintenance limit. The ICE coach in the leading position on track 3 had responses below the Amtrak comfort limit at reduced speed. The ICE coach in the trailing position on track 3 exceeded the comfort limit and at one point exceeded the Amtrak maintenance limit at 92 mph. The Metroliner exceeded the maintenance limit on both tracks 2 and 3 even at lower speeds. The vertical response of the vehicles to this interlocking is summarized in Figures 3.27 - 3.28.

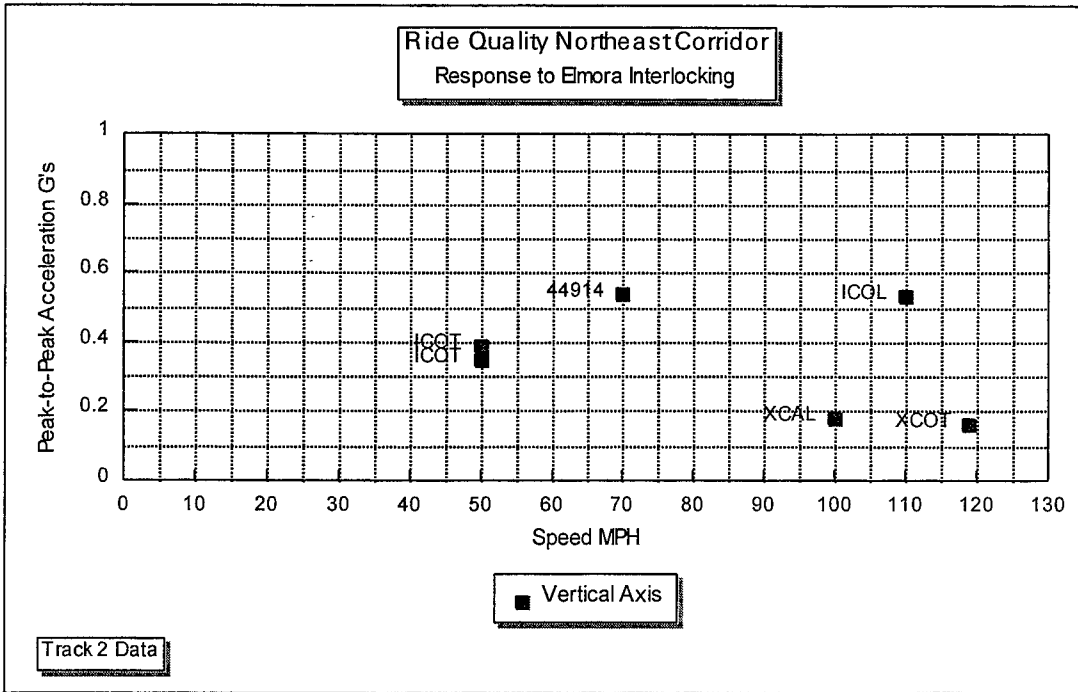

Figure 3.27 Response to Elmora Interlocking Track 2

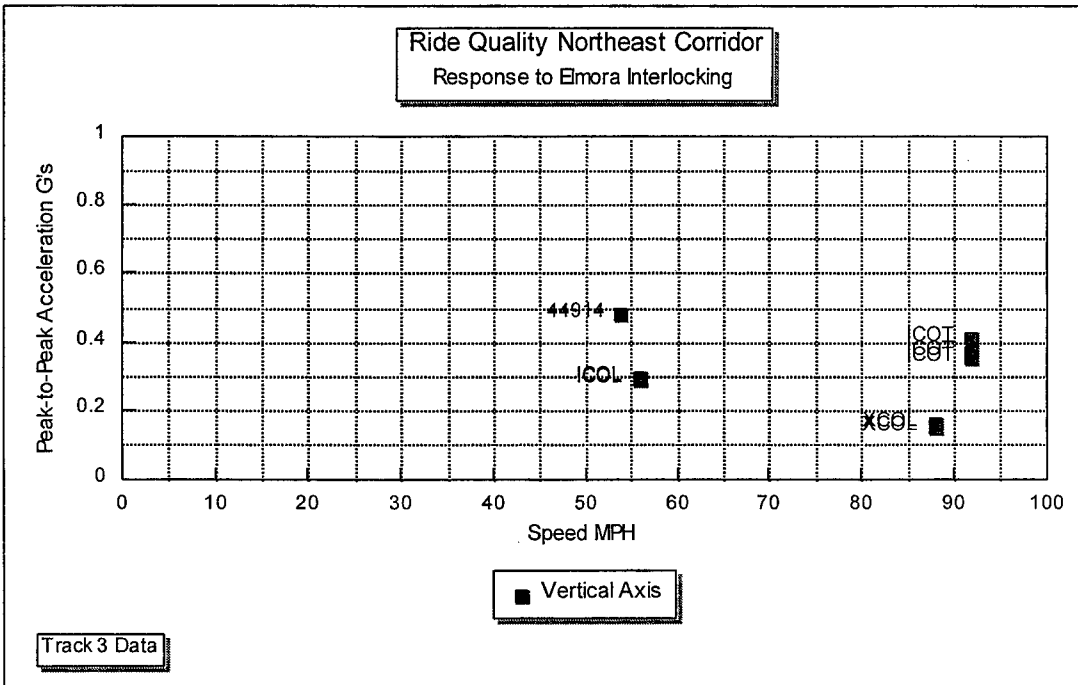

Figure 3.28 Response to Elmora Interlocking Track 3

3.2.2 County Interlocking

This interlocking represents a high speed interlocking on tangent track. The X2000 cab car was the only vehicle which had g levels below the Amtrak comfort level. The X2000 coach on track 2 exceeded the comfort limit but was below the maintenance limit. The ICE coach on track 2 exceeded the comfort limit in the trailing position (acceleration measured outboard), but exceeded the maintenance limit in the leading position (measured at coach centerline). On track 3, all vehicles exceeded the Amtrak maintenance limit. The X2000 had the smallest response at 0.45 g's. The ICE coach response was next highest at 0.50 g's. The Metroliner coach had the highest response of 0.55 g's. Vehicle response to this interlocking is shown in Table 3.3 below:

Table 3.3 Vertical Response to County Interlocking

Unit Code	Track	Speed	Vertical g's Peak to Peak
XCAL	2	135	0.24
XCOT	2	135	0.37
ICOT	2	128	0.32
ICOL	2	122	0.53
XCOL	3	135	0.45
ICOT	3	122	0.50
44914	3	90	0.55

3.2.3 Ride Quality Exception Zone Q3

The spiral entry to curve 355 caused ride quality exception reports during the first run of the ICE coach. This point was examined for all of the vehicles on both tracks 2 and 3. The X2000 cab car had responses below the Amtrak comfort limit. The X2000 coach was below the Amtrak comfort limit on track 3 and between the comfort and maintenance limits on track 2. The ICE coach greatly exceeded the Amtrak maintenance limit on track 2 at speeds above 70 mph. At 45 mph on track 2, the ICE coach had a response just below the Amtrak comfort limit. On track 3, the ICE coach in the trailing position exceeded the Amtrak maintenance limit at speeds from 128 mph to 95 mph. There was a trend for increasing g's with increasing speed for the ICE coaches. The Metroliner coach exceeded the Amtrak maintenance limit on both tracks. The response of the vehicles to this track disturbance is summarized in Figures 3.29 - 3.30.

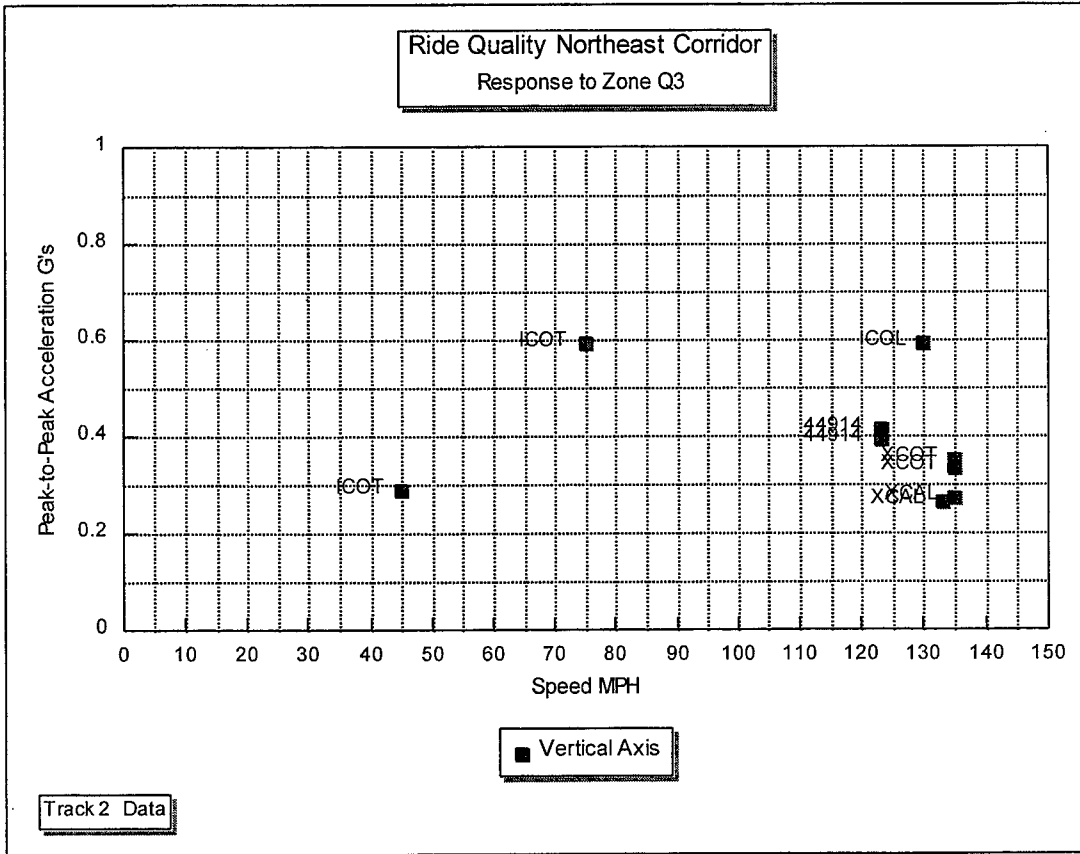

Figure 3.29 Response to Ride Quality Exception Zone Q3 Track 2

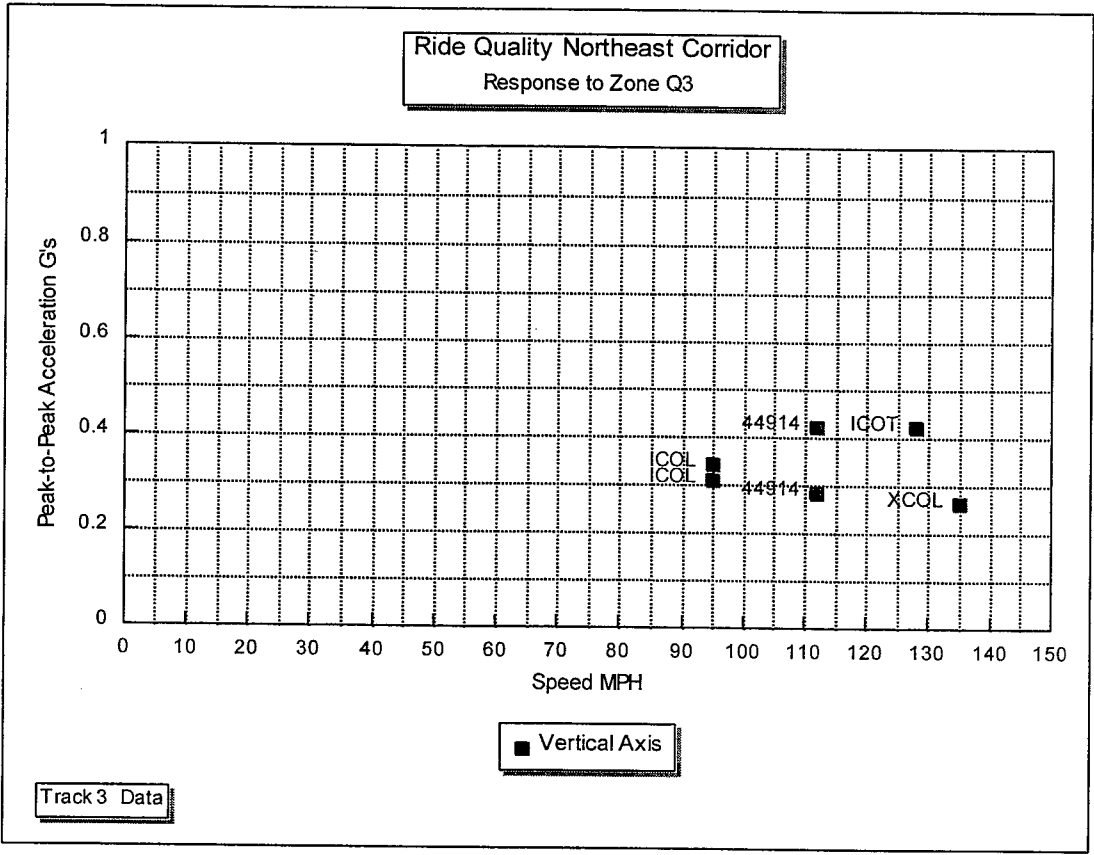

Figure 3.30 Response to Ride Quality Exception Zone Q3 Track 2

3.2.4 Ride Quality Exception Zone Q6

The section of the Northeast Corridor between the Hook and Baldwin interlockings crossed numerous undergrade bridges of short length and great age. All vehicles experienced vertical movement while traversing this track. The X2000 had responses below the Amtrak comfort limit on track 3 and above the Amtrak comfort limit on track 2. The ICE coach in the leading position on track 2 exceeded the Amtrak maintenance limit. The ICE coach in the trailing position on track 2 had responses at or just below the Amtrak comfort limit. On track 3, the ICE coach in the leading position (acceleration measured outboard) exceeded the Amtrak maintenance criteria. The ICE coach in the trailing position (acceleration measured on centerline) did not exceed the Amtrak comfort limit. The Metroliner exceeded the Amtrak comfort limit on track 2, and the Amtrak maintenance limit on track 3. The response of the vehicles to this track disturbance is summarized in Figures 3.31 - 3.32.

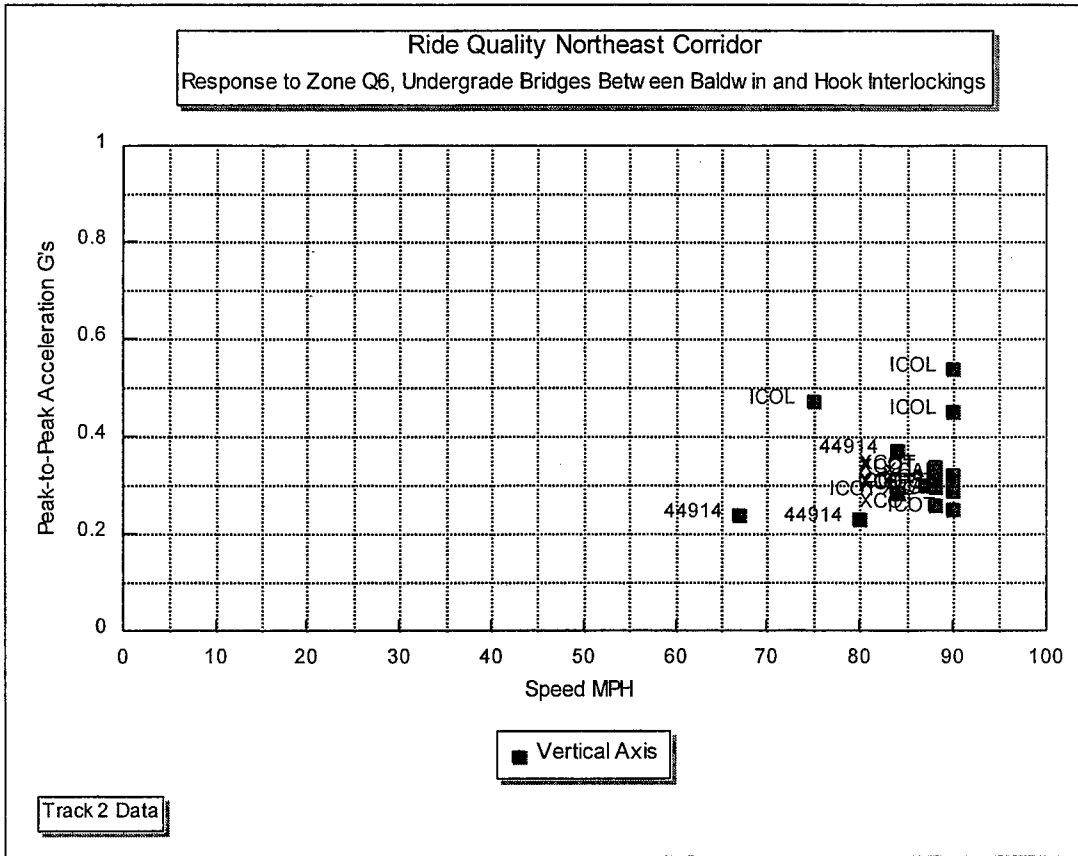

Figure 3.31 Response to Ride Quality Exception Zone Q6 Track 2

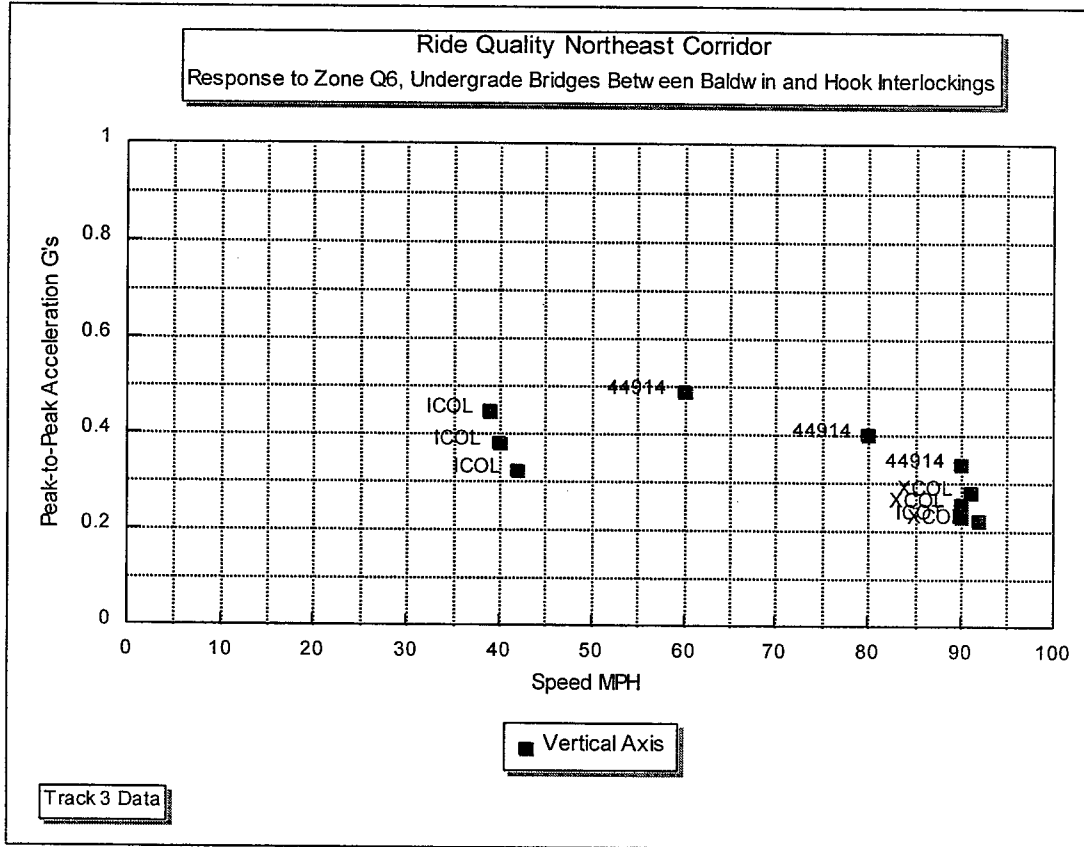

Figure 3.32 Response to Ride Quality Exception Zone Q6 Track 3

4. TALGO RIDE QUALITY EVALUATION

This section contains the results of tests conducted on the Talgo train for comparison to the other High Speed Trains tested on the NEC. In most cases, a direct comparison could not be made due to speed differences, however this section will discuss the comparisons that can be made and contains the supporting graphic information.

4.1 TALGO TEST SCHEDULE

The Talgo train was demonstrated on the NEC on March 21, 1994 on a run from Washington, DC to Philadelphia, PA and return. The demonstration was limited to 110 mph or normal track speed, whichever was lower. The Talgo coaches were hauled by two AEM-7 electric locomotives.

4.2 TALGO CONSIST

The Talgo train consisted of a hotel power car at either end with articulated coaches in between. The suspension system of the Talgo contains several features that are very different from any of the other high speed trains tested for ride quality on the NEC.

Each passenger car is articulated and has a single axle at the articulation point. The axle is really two stub axles so left and right wheels are independent. The body is suspended above its center of gravity with air springs and is arranged to passively tilt in response to lateral acceleration.

Traversing curves at speeds resulting in positive cant deficiency will tilt the body toward the center of the curve and decrease the uncompensated lateral acceleration felt by the passengers. Conversely, traversing a curve below balance speed with negative cant deficiency can cause the body to tilt toward the outside of the curve.

The ridemeter was set up behind an outboard seat in the first coach car. Its location was as close as possible to the single axle, a distance of approximately nine feet. Data was recorded continuously at 200 samples per second for later analysis. Data points for the Talgo are plotted as TCOT.

The speed profile of the test run from Philadelphia to Washington is shown in Figure 2.6 in the body of this report. The speed profile of a similar shakedown run made on March 19, 1994 is shown in Figure 4.1.

4.3 TALGO DATA ANALYSIS

The data collected on the Talgo was analyzed in the same manner as the other trains tested.

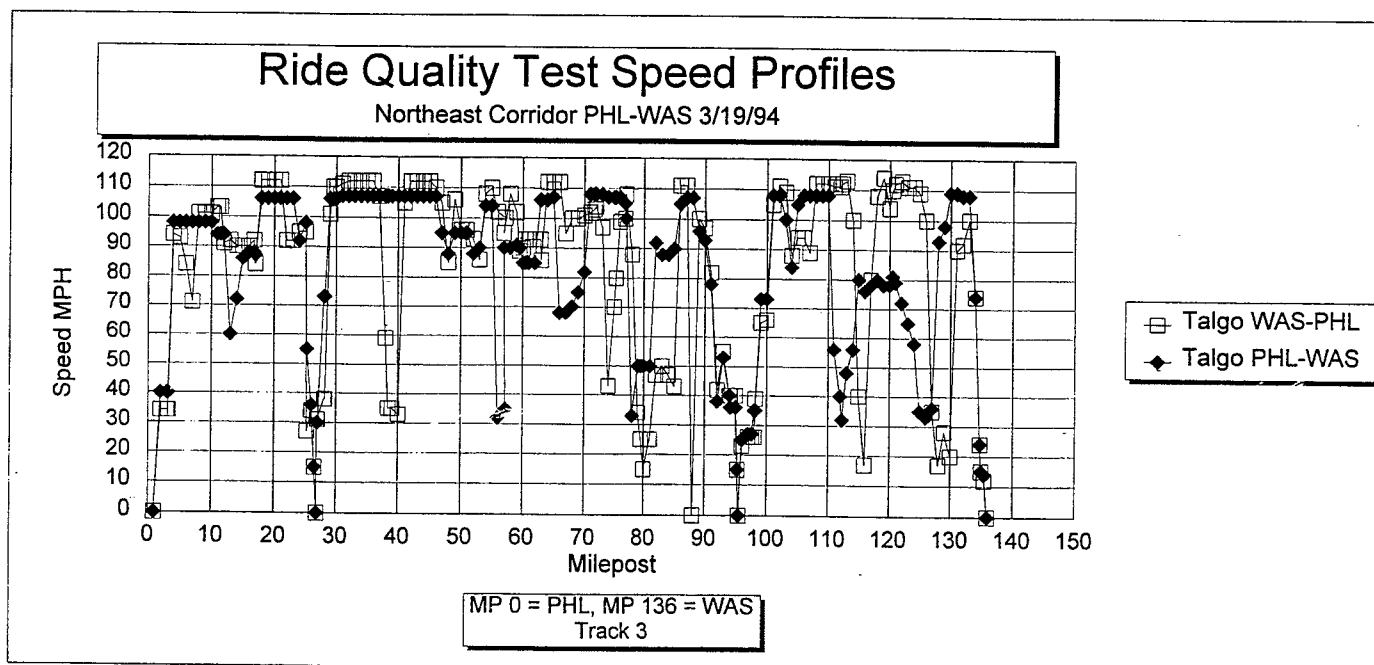

Figure 4.1 Talgo Speed Profiles

4.3.1 Tangent Track

Since the Talgo was limited to 110 mph, direct comparison of the Talgo to the other trains on the high speed tangent sections of the NEC could not be made. Also, the Talgo was not run north of Philadelphia over the T4 zone where the other trains were compared. Data for the Talgo was analyzed for only the T-2 tangent zone.

The Talgo provided the following ISO 2631 reduced comfort exposure times over this zone.

Track	Zone	Speed	Lateral Hrs.	Vertical Hrs.
2	T-2	110	7.4	29.6
3	T-2	110	6.0	15.8

The vertical ride quality from the Talgo at zone T-2 at 110 mph shown by the ISO 2631 reduced comfort limit exposure times is in the range of the best vertical ride quality experienced on the, ICE, and X2000 at zone T4 at speeds of 110-135 mph as shown in figures 3.6 and 3.7. The ISO 2631 exposure times for the lateral axis for tangent track at zone T2 were not as long as for the vertical axis. The 6-7.4 hour times are somewhat less than the exposure times for the X2000, ICE and Metroliner on zone T4 from figures 3.4 and 3.5.

4.3.2 Curving Track

Due to the limited test area of the Talgo, direct comparison of curving ride quality to the other trains shown in Figures 4.2 - 4.5 could not be made on a curve-by-curve basis. ISO 2631 reduced comfort exposure times were plotted for each of the curves in zones C1, C2, and C3. These plots may be compared to the data in section 3.1.2 for the other trains. The lateral and vertical ride quality of the Talgo coach did not appear to be a function of the cant deficiency in the limited range of cant deficiency experienced on the test run at the 110 mph speed limit.

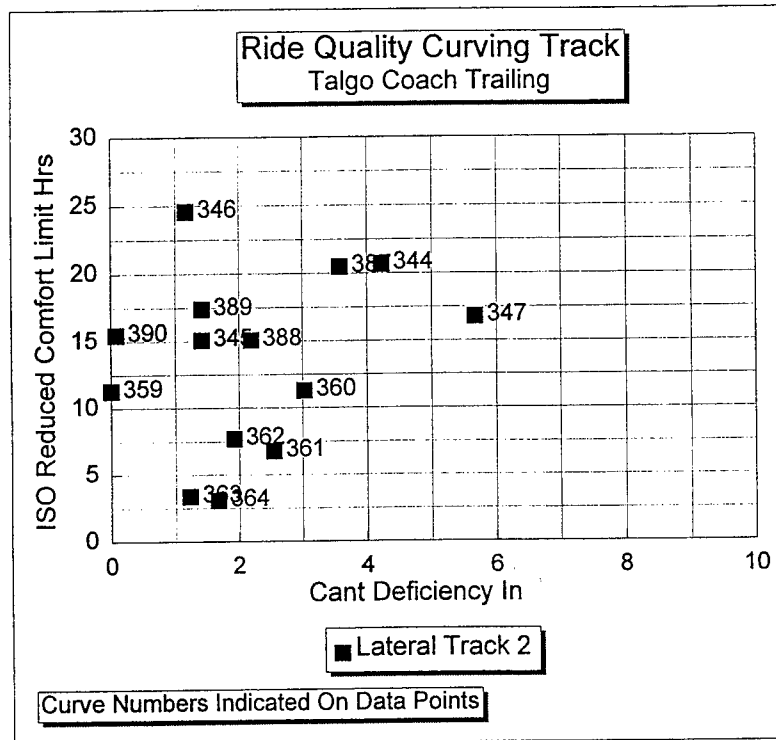

4.2 Talgo Curve ISO Data Lateral Axis Track 2

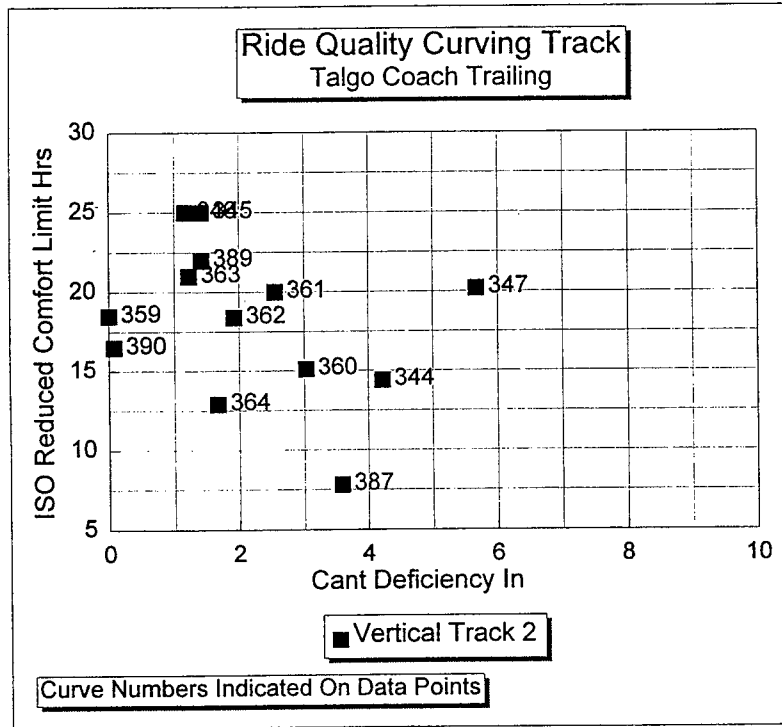

4.3 Talgo Curve ISO Data Vertical Axis Track 2

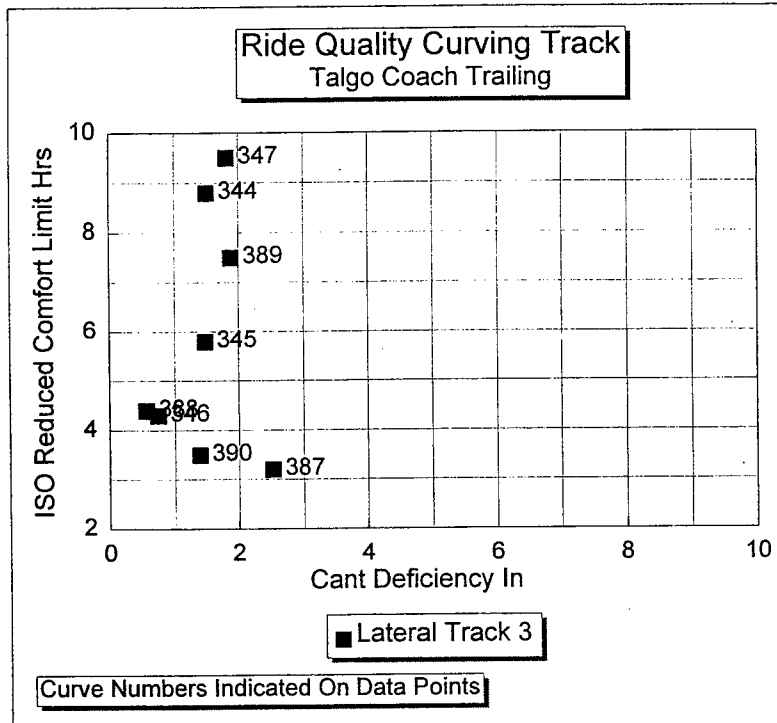

4.4 Talgo Curve ISO Data Lateral Axis Track 3

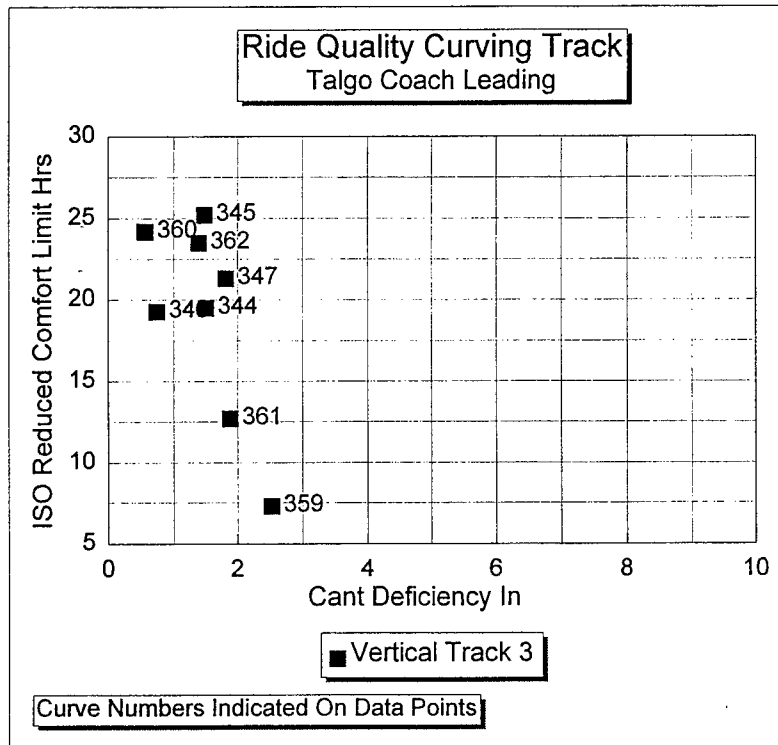

4.5 Talgo Curve ISO Data Vertical Axis Track 3

4.3.3 Time Domain Analysis

The vertical and lateral response of the Talgo was analyzed to track disturbances at interlockings and points of ride quality exceptions within the test run. In this case, test data from the other trains was available to allow a direct comparison. The Talgo’s vertical response to the spiral at curve 355 was considerably less than either the ICE or Metroliner at the same speed. The Talgo’s lateral response at the same location was higher and was not significantly different than the Metroliner or ICE at the 110 mph speed. A direct comparison could not be made at the Oak interlocking due to the Talgo’s slower speed, however the Talgo’s vertical and lateral response at that interlocking appeared to fall on the same trend line as the responses of the other trains at that location.

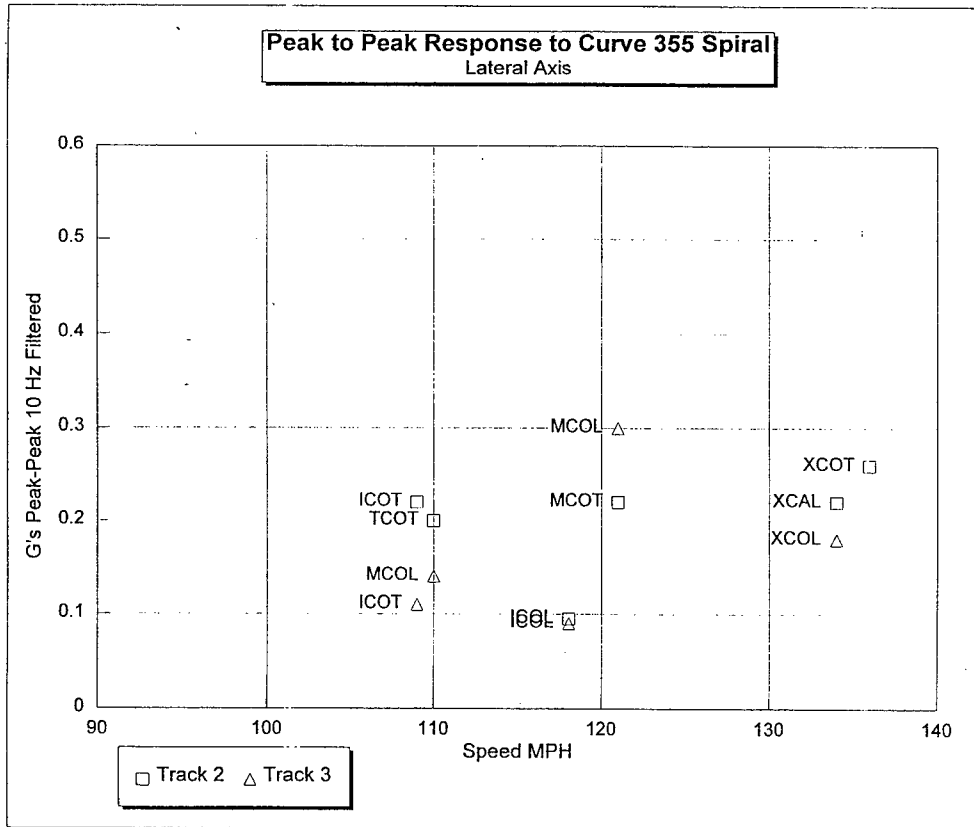

Figure 4.6 Talgo Lateral Response to Ride Quality Exception Zone Q3 Tracks 2 and 3

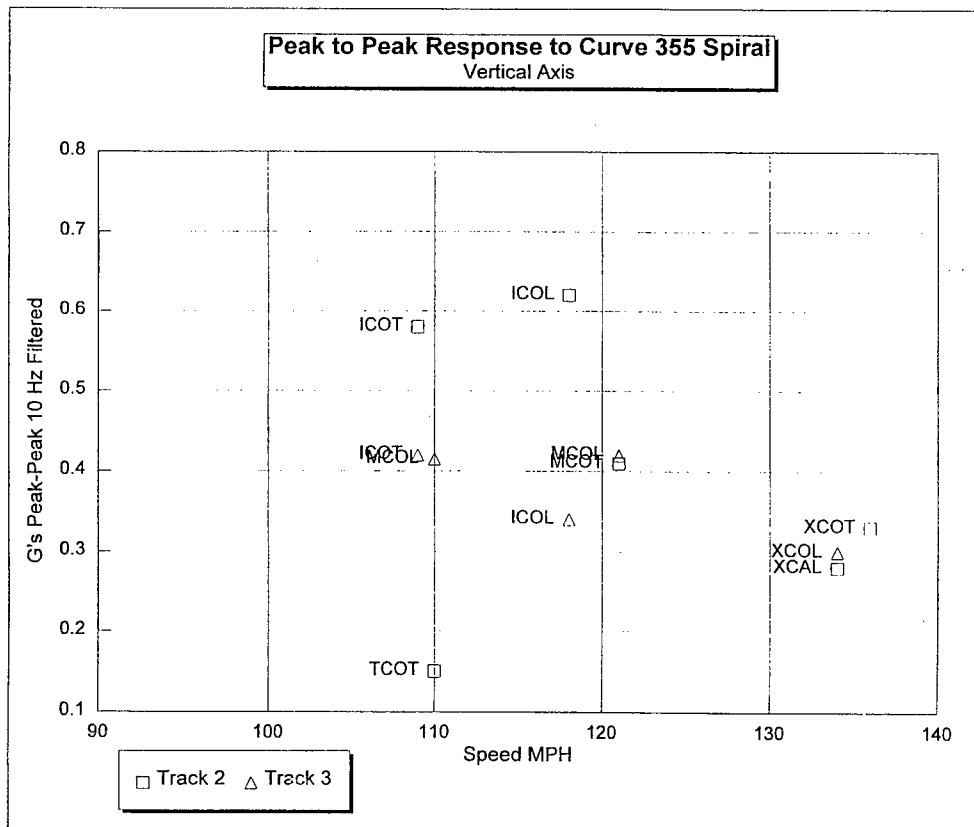

Figure 4.7 Talgo Vertical Response to Ride Quality Exception Zone Q3 Tracks 2 and 3

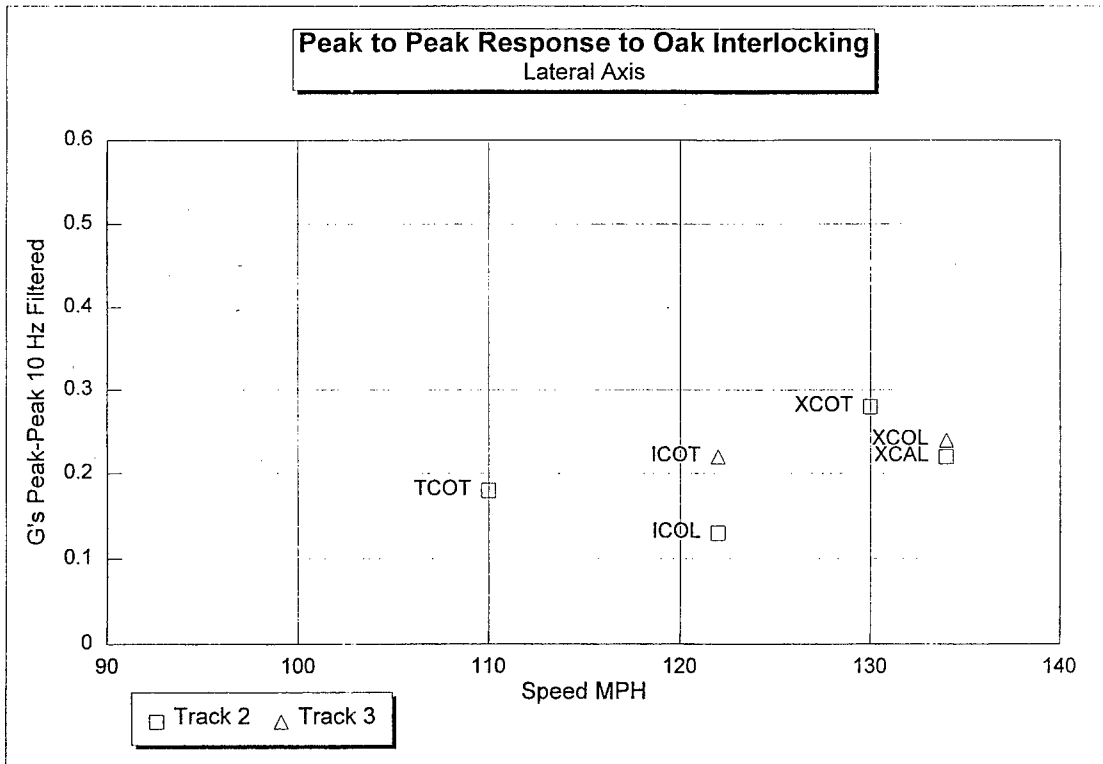

Figure 4.8 Talgo Lateral Response to Oak Interlocking Tracks 2 and 3

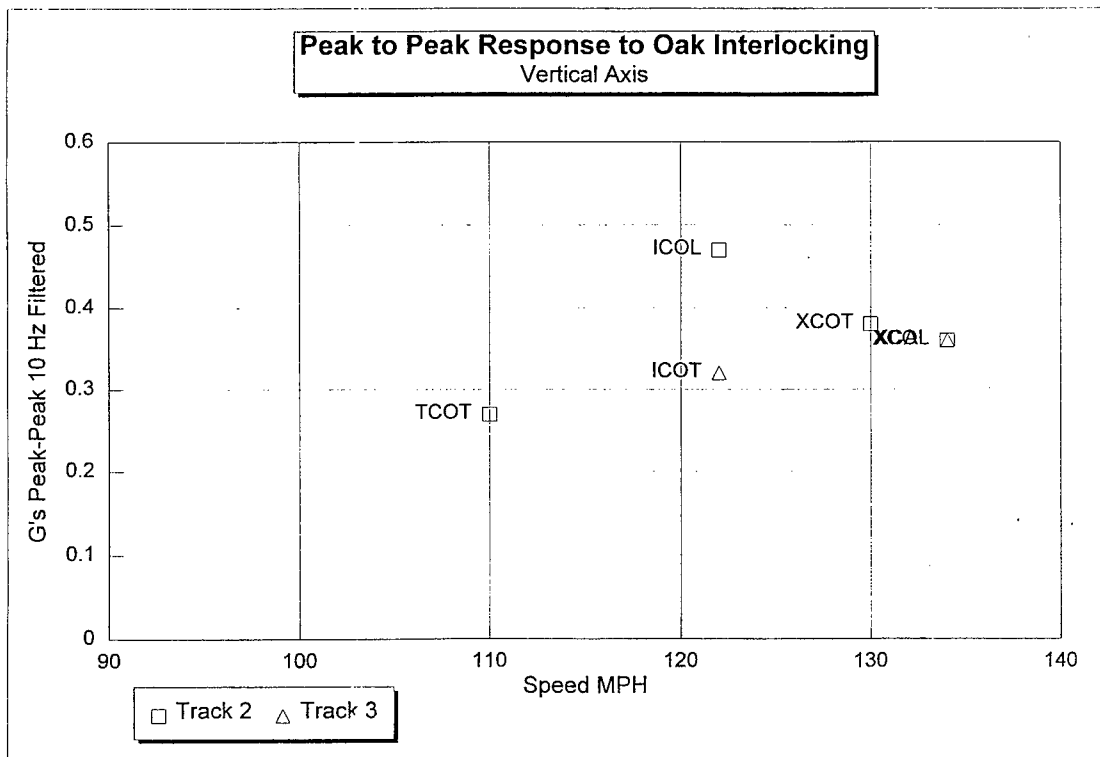

Figure 4.9 Talgo Vertical Response to Oak Interlocking Tracks 2 and 3

4.4 TALGO SUMMARY

The Talgo train rode well on tangent track at the speeds tested. The Talgo trainset appeared to be affected by the passage of other trains moving in the opposite direction more so than the other trainsets. The bow wave of air from the oncoming train would apparently impact the Talgo cars, causing the tilt mechanism to respond to a lateral force centered below the hinge points. The only area where the Talgo ride quality suffered was over bolted rail at speeds of approximately 25 mph. This was noticeable when entering and leaving each station. In these areas a sustained "rocking" lateral motion was very evident both in the data and to the passengers. An example of this phenomenon is shown in Figures 4.10 and 4.11 below. In this zone, the vertical ride quality was very good at 22 hours ISO Reduced Comfort Exposure time, however, the lateral ride quality was degraded to 3.1 hours ISO with a critical frequency of 0.8 Hz. This frequency is in the passenger nausea range and could be a factor in passenger acceptance.

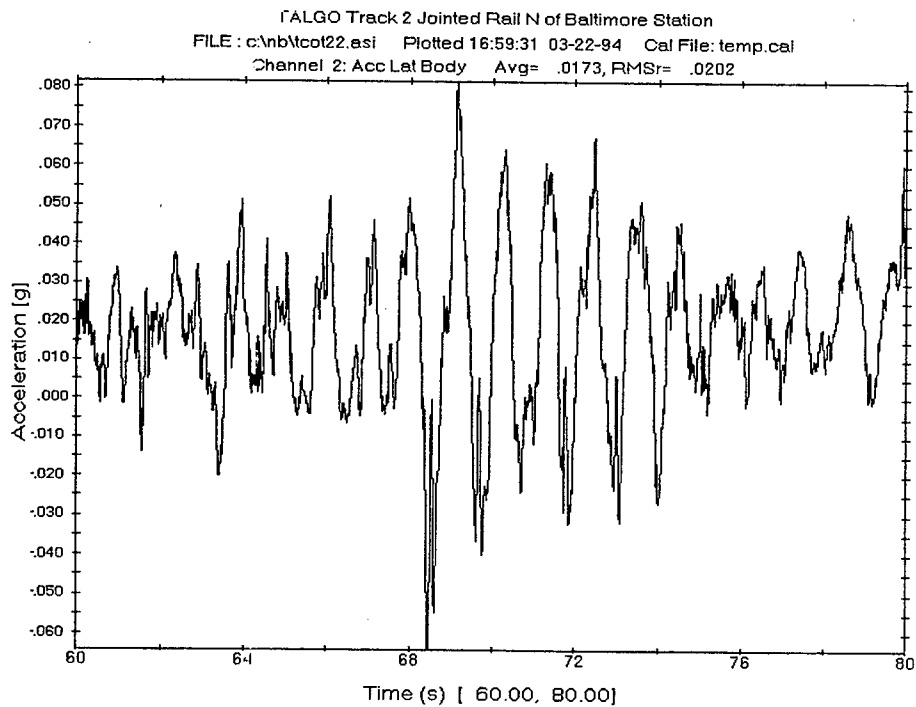

Figure 4.10 Talgo Time History on Bolted Rail

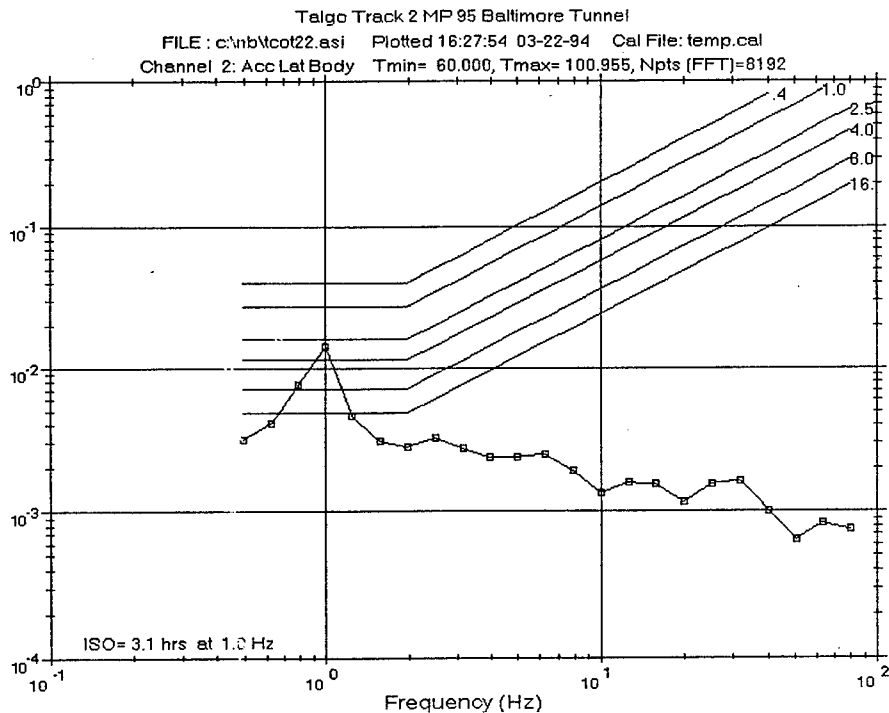

Figure 4.11 Talgo Lateral Ride Quality on Bolted Rail

5. CONCLUSIONS

The X2000 produced less dynamic response to track disturbances in the vertical axis than the other two vehicles.

The ICE and the X2000 provided essentially equivalent ISO Reduced Comfort exposure times for lateral vibration on tangent track.

The ICE and the Metroliner provided approximately 6-7 hours of exposure time before reaching the ISO Reduced Comfort limit for vertical vibration on tangent track. However, the ICE was traveling at 135 mph while the Metroliner was traveling at 125 mph. The X2000 provided approximately 13 hours of exposure time before reaching the ISO Reduced Comfort limit for vertical vibration on tangent track at 135 mph.

The X2000, the ICE and the Metroliner provided essentially equivalent ISO Reduced Comfort exposure times on curving track. However, the ICE and X2000 were tested at speeds 10-15 mph faster than the Metroliner.

The primary vibration frequency for determining ISO Reduced Comfort times was lower for the ICE than the other two vehicles.

The ICE and X2000 locomotives provided 5-6 hours of exposure time before reaching the ISO Reduced Comfort limit for vertical vibration at 135 mph.

The AEM-7 locomotive provided only one hour of exposure time before reaching the ISO Reduced Comfort limit in the vertical axis at 125 mph.

The Talgo coach provided approximately 23 hours of exposure time before reaching the ISO Reduced Comfort limit in both the vertical and horizontal axes on tangent track at 110 mph.

The Talgo coach had a high level of lateral acceleration at approximately 1 Hz on jointed tracks at speed between 30-45 mph. The corresponding ISO Reduced Comfort exposure times were approximately one hour.

6. REFERENCES

1. "Safety Relevant Observations on the X2000 Tilting Train", U.S. Department of Transportation, Federal Railroad Administration, March 1991, Washington, DC.
2. "Safety Relevant Observations on the ICE High Speed Train", U.S. Department of Transportation, Federal Railroad Administration, July 1991, Washington, DC.
3. "Engineering Data on Selected High Speed Passenger Trucks", FRA/ORD - 78/29 US Department of Transportation, Federal Railroad Administration July 1978, Washington, DC

APPENDIX A

OPERATING INSTRUCTIONS PORTABLE RIDE QUALITY MEASUREMENT SYSTEM (PROMS)

A.1 HARDWARE

The Portable Ride Quality Measurement System (PQRMS) is comprised of three basic units and cables as shown in **Figure A.1**:

- **Ride-Meter Box**, containing accelerometers, GPS receiver, signal conditioning boards, A/D converter, and battery power
- **Laptop Computer, (Toshiba T1960CS)**, including:
 - portable carrying case
 - side-mounted detachable mouse
 - spare battery pack
 - plug-in battery charger
- **GPS Antenna**, with magnetic mounting surface, and 16.4 ft (5 m) length of RG-183 type antenna cable and SMB connector
- **Cables:**
 - **Parallel port cable**, 25 pin connector, each end, 6 ft. in length
 - **Serial port RS-232 cable**, 9 pin connector, each end, 6 ft. in length
 - **Battery charger cord**, 110V 3-prong grounded each end, 6 ft. in length

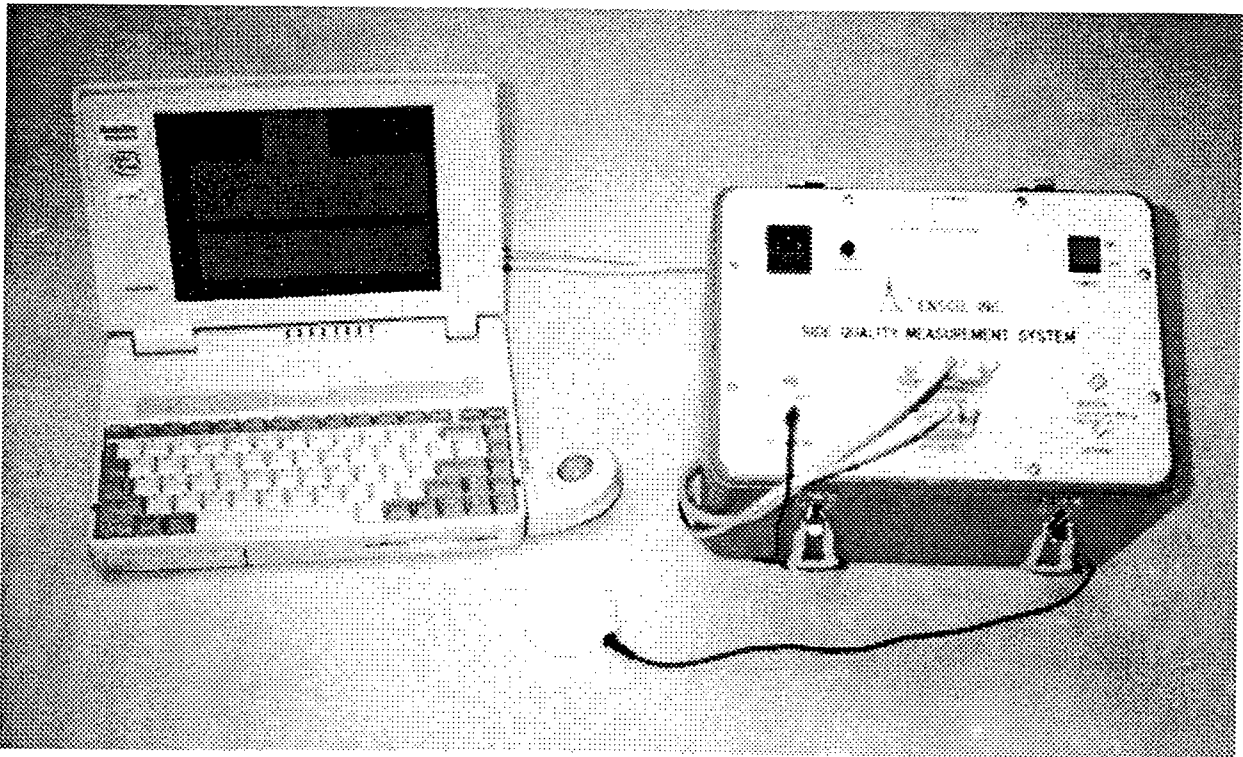

A.1.1 Hardware Setup

To use the PQRMS, the following steps are required:

1. Place the Ride-Meter Box at the location at which accelerations are to be measured. Arrows on the top panel of the Box indicate the axes and the orientation of the lateral accelerometer for correct placement.
2. Connect the parallel port cable from the Ride-Meter Box to the parallel port of the laptop computer (25 pin connectors).
3. Connect the RS-232 cable from the Ride-Meter Box to the serial RS-232 port of the laptop computer (9 pin connectors).
4. Connect the GPS antenna cable to the Ride-Meter Box, and place the antenna where satellite information may be received (e.g., on the roof of the vehicle).
5. Power-on the Ride-Meter Box; Power Switch on top of unit will illuminate RED.
6. Power-on laptop computer.

The PRQMS hardware is immediately ready for use; a two-minute warm-up period is recommended, however, to allow for complete stabilization.

A.1.2 Battery Charging

A lead acid battery, installed in the Ride-Meter Box, provides the necessary electrical power for the unit. Battery life, under normal operation, from the fully charged condition is nominally eight (8) hours. To charge the battery:

1. Turn the Ride-Meter Box Power Switch OFF.
2. Connect the battery charger cord from the Ride-Meter Box to a 110V AC power source.

While charging, a **green light** indicator on the top panel of the Ride-Meter Box will illuminate. This green light will **turn off** when the battery becomes **fully charged** or the Ride-meter is turned on; at this point, a trickle-charge condition is maintained until the battery charger cord is disconnected. Charging time, from low to full, is nominally four (4) hours.

During Ride-Meter operation, should the battery charge become low, an audible "beeper" sounds to inform the user that re-charging is required, and that a nominal time of thirty (30) minutes remains before the Ride-Meter will cease to function. To maximize the overall life of the battery, it is recommended that the battery never be allowed to become completely discharged.

A.2 SOFTWARE - DATA ACQUISITION

Data acquisition, storage, analysis, and display are controlled from the keyboard of the laptop computer. Custom software, installed on the fixed disk of the computer, provides this control under the MS-DOS Operating System. The operating system is configured to manage the necessary hardware (drivers) and to **keep at least 540 kilobytes of conventional memory (RAM)** available for the data acquisition and analysis software.

A.2.1 LABTECH NOTEBOOK

Ridometer data acquisition and real time display are controlled by the integrated software package, LABTECH NOTEBOOK Pro, which is commercially available from Laboratory Technologies Corporation. NOTEBOOK (NB) is installed on the hard disk of the laptop computer, in the directory named "NB", with the executable program of the same name, "NB.EXE".

NB has two parts: a **build-time** that enables the user to **configure** the data acquisition and display "**setup**" as needed for a particular test, and a **run-time** that performs the acquisition and control as defined in the setup. The **build-time** consists of **ICONview**, a graphical interface that allows the user to use icons as building blocks when designing the setup, combined with a system of menus. Two default setups have been defined for the Ridometer and are readily available for use at any time. The menus and definitions for these setups are described below, and may be used as a guideline by the user to define other customized setups as the need arises. For specific details and information, a reference manual on the use of LABTECH NOTEBOOK and its features is provided with the Ridometer.

A.2.2 Turn-Test Calibration

Each accelerometer in the PRQMS produces a high level DC output voltage proportional to the acceleration vector along its sensitive axis, and has a full linear response from DC (steady-state). Hence, under the influence of gravity along its sensitive axis, either + 1 g or -1 g (upside down), a voltage is produced which can be used to calibrate the system.

To facilitate a simple calibration, a program, **CAL**, is provided. This program is also used to check that the acceleration measurement equipment is operating correctly, and provides:

- a digital voltmeter display, indicating the voltage output from each accelerometer;
- a running plot of each accelerometer output voltage as the Ride-Meter Box is moved, turned, etc.

To run the program, the user should enter: **CAL**

To conduct a calibration, the user should press "C" on the laptop computer keyboard, follow the screen instructions, and answer the prompts. The calibration procedure involves placing the Ridemeter box sequentially in 4 orientations, pressing "Enter" after each orientation is achieved:

1. Level horizontally
2. On its Side (either side)
3. On its opposite Side
4. Level horizontally again

Voltage gains, offsets, sensitivities, etc. are displayed on the screen, and the user is prompted to have the program automatically create a calibration file for use with the analysis program TFPLOT (see Section A.3.4).

A.2.3 "FIXFILE" for Data Analysis

A quick and simple program, **FIXFILE**, is provided to adjust the data files acquired using the LABTECH NB Software, to a more convenient form for archival and for post-processing using the analysis program TFPLOT (see Section A.3).

Ridemeter data files acquired using the NB Software, in its default setup, are given a file name, ending with a number which is incremented automatically each time a new data acquisition session is started. For each session, two data files are created, one containing the recorded acceleration data, and one containing the recorded GPS data. NB will typically assign file names: **RIDE0.BIN** (acceleration data), **RIDE1.GPS** (GPS data). When the next acquisition session is conducted, the files will be given names: **RIDE2.BIN**, **RIDE3.GPS**; and so on. For archival and analysis, it is more convenient to adjust the file names to the same number (TFPLOT expects this), and to keep a record of the sampling rate and number of channels used during the data acquisition.

Program **FIXFILE** is provided to accomplish the above:

1. Adds a single 4-byte record to the beginning of the acceleration data file (e.g. **RIDE0.BIN**), recording the sampling rate and the number of channels used during the Labtech data acquisition.
2. Renames the .GPS data file to the same number as the acceleration data file name (e.g., renames **RIDE1.GPS** to **RIDE0.GPS**).

To execute this program, the user should enter: **FIXFILE *datafilename*** where:

datafilename is the name of the .BIN (acceleration data) file to be adjusted

e.g. **FIXFILE RIDE0.BIN**, or **FIXFILE RIDE0**, or **FIXFILE RIDE**

A.3 SOFTWARE - DATA ANALYSIS - TFPLOT

A.3.1 INTRODUCTION

"TFPLOT" is a post-processing program, designed to analyze any data file created and saved by the FRA/ENSCO Ride Quality Meter. The principal functions of TFPLOT are:

1. Plot the acceleration time history from each channel of data [lateral or vertical acceleration in units of "g" versus time in seconds]. If GPS data has been gathered, display by cursor the vehicle speed, global location, and distance to the nearest known landmark at any point on the time history signal.
2. Flag exceptions to the lateral or vertical acceleration data which exceed the acceptable thresholds for peak-to-peak, zero-to-peak, and steady state variation. If GPS data has been gathered by the ridemeter, indicate the global location of each exception and the distance from the nearest known landmark.
3. Transform the acceleration signals over a given time interval to the frequency domain, and produce a frequency spectrum plot [peak acceleration in units of "g" versus frequency in Hz].
4. Plot the RMS acceleration levels in third octave frequency bands, and determine the ISO weighted ride quality index [RMS acceleration in units of "g" versus frequency in Hz].

A.3.2 GENERAL PROCESSING DESCRIPTION

When the Ride-Meter is active, acceleration time history data, gathered at a given sampling rate, are stored as integer values in a named data file, in either ANSI Standard ASCII format or binary form. The data file always begins at time "zero" and contains data records of at least two channels of accelerations, in integer form, which continue at the sampling time interval for as long as the Ride-Meter is active; a data file may typically contain anywhere from a few minutes (hundreds of seconds) to a few hours (thousands of seconds) of sampled lateral and vertical accelerations.

The Ride-Meter, when active, may concurrently gather Global Positioning System (GPS) data at 1 second intervals. This data includes the latitude, longitude, and vehicle speed, and is stored in a separate ASCII format data file, having the same name as the acceleration data, but with a ".GPS" DOS extension.

TFPLOT accesses any or all of this data as directed by the user. TFPLOT reads the integer data in "blocks" of time, starting at a time specified by the user, converts them to acceleration values in engineering units ("g"), and facilitates analysis of each **time block**. A **time block** contains 28,001 data points of acceleration data (or less if the data file is small) for each channel and thus covers a time duration dependent on the sampling rate used by the Ride-Meter; for a Ride-Meter sampling rate of 200 samples per second, a **time block** covers a duration of 140 seconds of acceleration

data; for a sampling rate of 50 samples per second, a time block covers a duration of 560 seconds.

Within the program, TFPLLOT initially prompts the user for the **DATA FILE NAME**, in standard MS-DOS format (drive, pathname, etc. as required). The user is then prompted to specify any time block of interest by entering a "starting time" (in seconds) of the time block, referenced to time zero ($t=0$) as the beginning of the data file (the default is $t=0$, the start of the file). TFPLLOT will read a block of acceleration data from this time forward into memory for plotting and analysis. A simple keystroke of "N" or "+" will instruct TFPLLOT to read in the Next time block as required; a "-" will instruct TFPLLOT to go back 1 time block to the previous time block. A keystroke of "M" will Move to any specified time block, prompting for the requested starting time (in seconds) of the required time block.

Data within the defined time block is immediately available in memory for analysis and display in the time and frequency domains as instructed by the user. Other time blocks are quickly retrieved from the data file using the above mentioned keystrokes as required.

A.3.3 PROGRAM FLOW

The processing steps and program flow of TFPLLOT are summarized below. Prompts to the user in TFPLLOT are accompanied by the current values for the requested parameters, which are always placed and displayed in square brackets []; if no change is required to a particular value when prompted, "Enter" may be pressed to leave the value as is.

1. The user is prompted to enter the ride data FILE NAME in standard MS-DOS format (drive, pathname, etc. as required).
2. The user is prompted to define a time block of interest by entering the starting time of the block, referenced to time zero ($t=0$) as the beginning of the data file.

TFPLLOT reads a block of integer data from this time forward into memory and screen-prints the time interval in square brackets []; the user is also informed by a screen message if the data file contains data past the end time of this time block.

3. The user is prompted for the Name of the Calibration File which contains the necessary calibration factors to convert the sampled acceleration values in integer form to engineering units in "g" (see Section A.4).
4. The user is prompted to choose a filter cut-off frequency if a low pass digital filter is to be applied to the acceleration data before processing; if no digital filtering is to be applied, a cut-off frequency less than zero (e.g. -1) should be chosen. TFPLLOT uses, as a default, a simple, single pole digital filter; however, a 3 pole Butterworth filter can be chosen by the user by adding a ",3" after the filter cut-off frequency is specified (e.g. 10,3 specifies a filter cut-off frequency of 10 Hz using a 3 pole Butterworth filter). The chosen filter and cut-off frequency remain in effect in TFPLLOT until they are expressly changed (see the "Z" command).

5. The user is prompted for a **Plot Header**; this descriptive information can be up to 80 characters in length and will be placed at the top of every plot generated within TFPLLOT; it can be changed at any time using the "H" command.

The necessary preliminary information is now entered for TFPLLOT to proceed. The above prompts are not repeated unless they are specifically requested by the user.

6. The user is prompted for the Data Channel Number to be examined; in general, Channel 1 is the vertical acceleration; Channel 2 is the lateral acceleration.

7. The user is prompted for the **Plot or Analysis Type**:

T = Time History Plot

F = Frequency Plots

TF = Time and Frequency Plots

FA = Automatic Frequency Analysis of the time history, starting with the current time block and proceeding to the end of the data file (unless interrupted)

E = Exception Analysis for peak-to-peak accelerations exceeding a specified threshold within a specified time increment, starting with the current time block and proceeding to the end of the data file (unless interrupted)

Each of these plots/analyses and the commands and features associated with them are summarized below.

A.3.3.1 TIME HISTORY PLOT

If the time history (**Plot Type = T or TF**) is chosen, acceleration data for the selected channel number is immediately plotted on the screen over the specified time interval. At the top of the plot, the following information is displayed:

- the user-defined header
- the data file name, current time and date (when the plot is drawn), name of the calibration file used, and digital filter characteristics when applied
- the data channel number and description, and the following acceleration values in units of "g" taken from the displayed time interval:
 - the average acceleration
 - the relative RMS acceleration (relative, in that the average acceleration over the time interval has been subtracted from the actual RMS value)
 - the extreme acceleration values (minimum and maximum)

When the screen-plot is complete, TFPLLOT awaits a keystroke instruction from the user. For analysis and display purposes, the user has several options as listed below.

Keystroke	Action
PrintScreen	The normal DOS print screen option in which the bit-mapped image on the screen is sent to the system printer to produce a hardcopy. TFPLLOT must wait while the DOS print screen process is being executed.
P	Print a hardcopy of the plot if an HP LaserJet Printer is connected to the system; TFPLLOT issues a screen message "Printing Plot ..." while the screen plot is quickly sent to the printer; a screen message "1 file(s) copied" confirms after a few seconds that the print is completed, and control is returned to TFPLLOT.
E	Any Exceptions to the specified peak-to-peak acceleration thresholds which occur on the current time history plot are listed on the screen; after the exceptions have been listed, a hardcopy may be obtained using the "PrintScreen" key.
Enter	Prompt for a new channel and new plot.
R	Rescale the y axis; the user is prompted for the minimum and maximum acceleration values to define the "y" axis scale, and a grid marking length if desired. The scale information should be entered as: Ymin, Ymax, YG; each value should be separated by a comma or a blank. Commas can be used as placeholders if a value is to be kept the same (e.g. ,1 will leave Ymin unchanged, and change Ymax to 1). The time history plot of the acceleration signal is immediately re-plotted using the defined scale. These scale values for the current Channel Number remain in effect until specifically changed by the user.
A	Scale the "y" axis to include All the acceleration data on the plot; this ensures that no acceleration peaks will be off-scale in the plot. The time history plot of the acceleration signal is immediately re-plotted using a scale which includes all the data. These scale values remain in effect until specifically changed by the user.
D	Default the "y" axis acceleration scale automatically to that generally used for ride quality examination: <ul style="list-style-type: none"> • for vertical acceleration, the "y" axis is set such that Ymin = 0.70 g, Ymax = 1.30 g [0.70,1.30]; • for lateral acceleration, the "y" axis is set such that Ymin = -0.30 g, Ymax = +0.30 g [-0.30,+0.30]. The time history plot of the acceleration signal is immediately re-plotted using the default scale. These scale values for the current Channel Number remain in effect until specifically changed by the user.
T	Change the Time bounds (the x axis) within the current time block; the user is prompted for the minimum and maximum time values to define the "x" axis scale, and a grid marking length if desired. The scale information should be entered as: Tmin, Tmax, TG; each value should be separated by a comma or a blank. Commas can be used as placeholders if a value is to be kept the same (e.g. ,100 will leave Tmin unchanged, and change Tmax to 100). If a time value outside the current time block is entered, the starting or ending time of the time block is used as appropriate.

Keystroke	Action
→ ←	Pressing the right or left cursor key initiates a vertical cursor line which moves to the right or left across the plot; when pressed as a single keystroke, the cursor moves exactly one data point to the right or left across the plot. The cursor location in time and the acceleration value at this time are always displayed below the lower left corner of the time history plot. Several successive keystrokes or a continuous pressing of the right or left cursor key accelerates the cursor to the right or left.
alt → alt ←	Holding the "alt" key down while pressing the right or left cursor key accelerates the cursor to the right or left (a factor of about 10 times the speed).
↑	During cursor operation, the up-arrow key can be pressed to Mark time boundaries within the time history plot. That is, the cursor is moved right or left to a time location of interest; a first depression of the up-arrow key marks this time bound, and the cursor is then moved right or left to a second time location; a second depression of the up-arrow key marks the second time bound and a bounding rectangle is drawn around the acceleration signal defined by the marked time bounds. The mean value of the acceleration within this time bound and the RMS value are displayed above the rectangle.
tab shift tab	Zoom in or out in time at the cursor position on the acceleration signals
I	Integrate the time history signal over the current time interval displayed on the screen. The user is prompted to enter a value for "speed" (1st integral of acceleration) at the integration starting time in units of "mph" and an "acceleration offset" in units of "g"; the offset is a correction to the acceleration signal to refine the accuracy and minimize the accumulating error in the integration process. A "velocity" vs time plot is produced as the 1st integral. If I is pressed again following this plot, a 2nd integral will be performed and a "distance" vs time plot will be displayed. The display keystrokes (P,R,A,D,→,←) outlined in this table may be used after each displayed plot.
H	Change the Header; the user is prompted to enter a new header to be printed at the top of each plot. This header remains in effect until specifically changed by the user.
1 2 etc	Change the channel number to the number entered; if a number is entered for which there is no data, no action is taken.
+ or N	Retrieve the Next time block of data from the data file, read the data into memory, and do a time history plot of the current channel number over the new time interval. The new time interval will begin at the exact end time of the current time block. Note: if there is no further data in the data file past the present time block interval, no action is taken.
-	Retrieve the Previous time block of data from the data file, read the data into memory, and do a time history plot of the current channel number over the new time interval. The new time interval will end at the exact start time of the current time block. Note: if the current time block is at the beginning of the data file (time zero), no action is taken.
M	Move to a new time block anywhere within the current data file; the user is prompted for the starting time of the time block in "seconds".

Keystroke	Action
C	Change to another data file; the current data file is closed and the user is prompted for a new data file name and the necessary information outlined in Section A.3, Steps 1) - 7).
Z	Change the low-pass digital filter characteristics applied to the time history; the user is prompted to enter a filter cut-off frequency and the number of poles as outlined in Section A.3, Step 4). These characteristics remain in effect until specifically changed again by the user.
Q	QUIT the program or the current data file; prompts are issued to the user to confirm this action.
esc	Displays a menu of the TFPLOT Commands on the screen as a help file.
F	Go directly to the Frequency plots; the user is prompted for the necessary information for the frequency plots as given in Section A.3.2.
G	Register GPS Track Map File Name; a data file containing previously gathered GPS locations of identified landmarks such as mileposts, bridges, etc

A.3.3.2 FREQUENCY DOMAIN PLOTS

If the frequency plots (**Plot Type** = F or TF, or keystroke F at the completion of a time history plot) are chosen, TFPLOT transforms the acceleration signal over the time interval to the frequency domain, and produces, in order:

- A. a Narrow Band Frequency Spectrum plot on a log-log scale, of peak acceleration in units of "g" versus frequency in Hz;
- B. a 1/3rd Octave Band Frequency plot on a log-log scale, of RMS acceleration level in each 1/3rd octave band in units of "g" versus center frequency in Hz.

Before plotting, for the first frequency plot only, the user is prompted for information concerning the type of frequency analysis to be performed as follows:

1. The user is prompted to confirm the use of a Fast Fourier Transform (FFT) to transform the time domain signal (over the time interval [Tmin,Tmax] selected for the time history plot) to the frequency domain; this is the default method which is executed quickly. The FFT will operate on the time signal, beginning at the starting time, Tmin, up to a number of data points equal to the maximum power of "2" (2^m) within the specified time interval (e.g. 512, 1024, 2048, 4096, 8192); in TFPLOT, the maximum number of points that can be used for the FFT is 8192 (2^{13}), which, for a sampling rate of 200 samples per second from the Ride-Meter, corresponds to a time interval of $8191/200 = 40.955$ seconds. The actual time interval used by the FFT is displayed at the top of the narrow-band frequency plot.

TFPLOT offers the option to use a Fourier Integral Transform for the frequency analysis if the FFT is not wanted (e.g. if an exact time interval is to be examined not corresponding to some power of 2 data points). The integral transform is much slower in execution and is selected by answering "N" (for NO) to the FFT prompt.

2. The user is prompted to select a weighting function or "time window" to be used for the frequency transformation; TFPLOT offers two window types having fixed characteristics, a standard Rectangular Window (R) or a Hanning Window (H). The rectangular window is simply a unity value weighting of the time signal within the time interval, which, for continuous signals, may result in more "leakage" and ripple in the frequency band. The Hanning Window applies a " $1 - \cos(2\pi t)$ " weighting to reduce ripple and improve selectivity.

The above prompts are issued only when the first frequency plot is requested. The frequency analysis parameters can be changed at any other time using the "S" command.

The narrow band frequency spectrum is immediately plotted on a log-log scale. At the top of the plot, the following information is displayed:

- the user-defined header
- the data file name, current time and date (when the plot is drawn), name of the calibration file used, and digital filter characteristics when applied
- the data channel number and description
- the time interval in seconds, [Tmin,Tmax], over which the frequency transformation was performed
- for the FFT, the corresponding number of acceleration data points used in the transformation

When the screen-plot is complete, TFPLOT awaits a keystroke instruction from the

user. For analysis and display purposes, the user has several options at this point as listed below.

Keystroke	Action
PrintScreen	The normal DOS print screen option in which the bit-mapped image on the screen is sent to the system printer to produce a hardcopy. TFPLOT must wait while the DOS print screen process is being executed.
P	Print a hardcopy of the plot if an HP LaserJet Printer is connected to the system; the screen plot is quickly sent to the printer and control is returned to TFPLOT.
enter	Erase the narrow band frequency plot and plot the 1/3rd octave band frequency analysis
R	Rescale the y axis; the user is prompted for the minimum and maximum acceleration values to define the "y" axis scale. The scale information should be entered as: Ymin, Ymax, with the values separated by a comma or a blank. A comma can be used as a placeholder if Ymin is to be kept the same (e.g. ,.1 will only change Ymax to .1 or 10^{-1}). The narrow band frequency spectrum is immediately re-plotted using a log scale rounded to the nearest power of 10 to maintain octaves. These scale values for the current Channel Number remain in effect until specifically changed by the user.
A	Scale the "y" axis to include All the acceleration data on the plot as a function of frequency; this ensures that no acceleration peaks will be off-scale in the plot. The narrow band frequency spectrum is immediately re-plotted using a log scale which includes all the data. These scale values remain in effect until specifically changed by the user.
D	Default the "y" axis acceleration scale automatically to that generally used for ride quality examination; these values have been chosen as 10^{-4} g to 10^{-1} g covering 3 octaves. The narrow band frequency spectrum is immediately re-plotted using the default scale. These scale values for the current Channel Number remain in effect until specifically changed by the user.
B	Superimposes British Railways Ride (BR) Index lines (ride index units defined by Sperling) on the narrow band frequency plot, and prints the maximum BR Index and corresponding frequency in the lower left corner of the plot.
→	Pressing the right cursor key initiates a vertical cursor line which moves to the right across the plot; when pressed as a single keystroke, the cursor moves exactly one data point to the right across the plot. The cursor location in frequency and the peak acceleration value at this frequency are always displayed below the lower left corner of the frequency plot. Several successive keystrokes or a continuous pressing of the right cursor key accelerates the cursor to the right.
alt →	Holding the "alt" key down while pressing the right cursor key accelerates the cursor to the right (a factor of about 10 times the speed).

Keystroke	Action
←	Pressing the left cursor key moves the vertical cursor line to the left across the plot; when pressed as a single keystroke, the cursor moves exactly one data point to the left across the plot. Again, the cursor location in frequency and the acceleration value at this frequency are always displayed below the lower left corner of the frequency plot. Several successive keystrokes or a continuous pressing of the left cursor key accelerates the cursor to the left.
alt ←	Holding the "alt" key down while pressing the left cursor key accelerates the cursor to the left (a factor of about 10 times the speed).
H	Change the Header; the user is prompted to enter a new header to be printed at the top of each plot. This header remains in effect until specifically changed by the user.
esc	Displays a menu of the TFLOT Commands on the screen as a help file.

After the narrow band frequency spectrum, the 1/3rd Octave Band Frequency spectrum is plotted on a log-log scale. The same information as for the narrow band plot is displayed at the top of the plot.

When the screen-plot is complete, TFLOT awaits a keystroke instruction from the user. For analysis and display purposes, the user has several options at this point as listed below.

Keystroke	Action
PrintScreen	The normal DOS print screen option (see narrow band frequency plot keystrokes).
P	Print a hardcopy of the plot if an HP LaserJet Printer is connected to the system.
Enter	Prompt for a new channel and new plot.
R	Rescale the y axis (see narrow band frequency plot keystrokes).
A	Scale the "y" axis to include All the acceleration data (see narrow band frequency plot keystrokes).
D	Default the "y" axis acceleration scale (see narrow band frequency plot keystrokes).
T	Change the Time bounds (the x axis) within the current time block (see time history plot keystrokes).
→	Move cursor line to the right (see narrow band frequency plot keystrokes).
alt →	Quickly move cursor to the right (see narrow band frequency plot keystrokes).
←	Move cursor line to the left (see narrow band frequency plot keystrokes).
alt ←	Quickly move cursor to the left (see narrow band frequency plot keystrokes).
H	Change the Header (see time history plot keystrokes).

Keystroke	Action
1 2 etc	Change the channel number to the number entered (see time history plot keystrokes).
+ or N	Go to the Next acceleration time interval; if Plot Type = F, do a frequency analysis on this next time interval and plot the results; if Plot Type not = F, retrieve next time block of data (see time history plot keystrokes).
-	Retrieve the Previous time block of data (see time history plot keystrokes).
M	Move to a new time block (see time history plot keystrokes).
C	Change to another data file (see time history plot keystrokes).
Q	QUIT the program or the current data file; prompts are issued to the user to confirm this action.
esc	Displays a menu of the TFPLLOT Commands on the screen as a help file.
F	Return directly to the current Frequency plots.

A.3.3.3 AUTOMATIC FREQUENCY ANALYSIS

If the automatic frequency analysis (**Plot Type = FA**) is chosen, TFPLLOT begins with the current time block, processing the acceleration data in the frequency domain for each channel number, using the current frequency analysis parameters. The RMS acceleration levels in third octave frequency bands and the ISO weighted ride quality index over each time interval are placed in disk files in ASCII format for future analysis (for use in a separate analysis program such as "PROCESS"). Lateral and vertical data are separated and appended to disk files, "ISORIDE.LAT" and "ISORIDE.VER" respectively. TFPLLOT continues performing the frequency analysis for succeeding time blocks of data, until the end of the data file is encountered. The user can interrupt and stop the analysis at any time by pressing the "Q" key once and waiting for the current time interval to be completed.

A.3.3.4 EXCEPTIONS ANALYSIS

If the exceptions analysis (**Plot Type = E**) is chosen, the acceleration data for the **current channel number** is examined for variations in acceleration which exceed a specified threshold. The type of variation is chosen by the user; the available options are: peak-to-peak, zero-to-peak, or steady-state. The user is first prompted to specify the following:

- the peak-to-peak threshold in units of "g" above which any detected variations will be flagged and recorded; for peak-to-peak variations, this value is generally taken as 0.25 g for lateral acceleration, and 0.30 g for vertical acceleration; for zero-to-peak and steady-state variations, the thresholds are dependent on the vehicle characteristics and will vary from vehicle to vehicle.

- the maximum time increment over which an occurrence is to be considered; this time increment is generally taken as:
 - peak-to-peak, 1.0 seconds.
 - zero-to-peak, 0.0 seconds (must be specified as a zero time to examine a zero-to-peak occurrence).
 - steady-state, -2.0 seconds (must be specified as a negative time to examine a steady-state occurrence).

TFPLOT begins with the current time block, searching the current channel number acceleration data for any peak-to-peak variations occurring within the specified time increment which exceed the specified threshold. The time of each exception and the peak-to-peak acceleration are placed in a disk data file in ASCII format for printing or future analysis (for use in a separate analysis program). The name of the disk data file will be that of the original data file, with the extension ".EXC". TFPLOT continues performing the exception analysis for succeeding time blocks of data, until the end of the data file is encountered. The user can interrupt and stop the analysis at any time by pressing the "Q" key once and waiting for the current time interval to be completed.

At the completion of the exception analysis, the user is prompted to "print" the exception report if desired.

A.3.4 CALIBRATION FILES

A calibration file, in the format described below, must be provided to TFPLOT in order to display the acceleration data in correct engineering units. This calibration file is separated from the program to provide versatility in the application of the Ride-Meter and to facilitate small corrections to the daily calibration of the Meter to account for voltage "drift", etc. A default calibration file, named "TFPLOT.CAL", is provided with TFPLOT and contains the necessary calibration information when the Ride Meter is used in its normal mode of operation. The contents of "TFPLOT.CAL" are listed below.

FILE: TFPLOT.CAL (ASCII Text Format)

Line 1:	VOLTAGE CALS - Ride Meter Model 200 - May 22, 1994				
Line 2:	CHN	SEN	VOFF	VGAIN	
Line 3:	1	1	-0.0910	4.7743	acc body vert
Line 4:	2	2	0.0428	0.9480	acc body lat
Line 5:	3	9	0.0000	1.0000	battery voltage

The calibration file must contain 2 header lines (lines 1 and 2) that contain comment information which is not used by TFPLOT. Each successive line (lines 3,4 ...) must contain, in order, the following information in free format:

- the A/D channel number in which a particular signal was sampled and stored in the time history data file by the Ride Meter; generally, channel 1 = vertical acceleration; 2 = lateral acceleration; 3 = Ride Meter battery voltage.
- the sensor "designation number" of the sensor that was connected to this A/D channel number of the Ride Meter for the particular data collection; a list of the available sensor "designation numbers" is given below and are contained in an external data file named "SENCALS.DAT".
- the voltage offset or error in the Ride Meter output for a given sensor input, in volts; the offset for an accelerometer channel can be determined by a "turn test" calibration of the Ride Meter; a non-zero offset might arise from amplifier electronic drift.
- the voltage gain of the amplifier and conditioning electronics in the Ride Meter, in units of "A/D volts per sensor volt"; this value does not generally change, and, for an accelerometer, can be checked by a "turn test" of the Ride Meter.
- comment text on the particular channel

The sensors which might be used with the Ride Meter, their "designation numbers", and the necessary calibration data for these sensors is contained in a disk file "SENCALS.DAT". **This file is now incorporated into the TFLOT software and is no longer required.** The file is kept only for maintenance purposes and is updated only if new sensors are incorporated into the Ride Meter or if a particular sensor fails in some sense and must be replaced or re-calibrated.

FILE: SENCALS.DAT (ASCII Text Format)

```

Line 1:          SENSOR CALIBRATION FACTORS - Ride Meter Model 200 - March 1994
Line 2:           1  1.0000  0.995  !Acc Vert Body [g]  Acc#1520
Line 3:           2  0.0000  0.198  !Acc Lat Body [g]  Acc#2212
Line 4:           3  1.0000  1.008  !Acc Vert Body [g]  Acc#2766
Line 5:           4  0.0000  1.076  !Acc Long Body [g]  Acc#1561
Line 6:           9  0.0000  1.000  !System Volts [V]  Power Supply
Line 7:          10  0.0000  1.000  !Acceleration [g]  Calibration
Line 8:          11  0.0000  1.000  !Track Gage [in]   Track Input
Line 9:          12  0.0000  1.000  !Crosslevel [in]   Track Input
Line 10:         13  0.0000  1.000  !Right Profile [in] Track Input
Line 11:         14  0.0000  1.000  !Right Alignment [in] Track Input
Line 12:         15  0.0000  1.000  !Average Profile [in] Track Input

```

A.3.5 SUPPORTING FILES REQUIRED

Main Program: TFLOT.EXE
~~Sensor Calibration File: SENCALS.DAT~~
Voltage Calibration File: TFLOT.CAL, or created/named by the user or program CAL

Screen Plot Font File: HELVB.FON
Exceptions List Font File: COURB.FON
TFPLOT Help File: TFPLOT.HLP

A.3.6 OUTPUT FILES FROM TFPLOT

TFPLOT.INI Current parameters used in TFPLOT are saved in this file for the next execution of TFPLOT.

ISORIDE.LAT ISO ride analysis, 1/3rd octave band results for lateral acceleration

ISORIDE.VER ISO ride analysis, 1/3rd octave band results for vertical acceleration

datafilename.EXC Exception results for peak-to-peak accelerations above thresholds

datafilename**A.BMP** As requested by the user with the "**W**" command, bitmap images

 "**B.BMP** of any plot, specifically formatted for presentation, etc. using the

 etc. Microsoft Windows Paint program. As each image is requested,

 the bitmap storage **FILE NAME** is incremented automatically in

 alphabetical fashion from "A" to "Z" allowing for 26 different

 bitmaps at any time.

A.3.7 EXECUTABLE PROGRAMS ASSOCIATED WITH TFPLOT

CAL.EXE

FIXFILE.EXE

TFCAL.EXE

DATA ACQUISITION - Using Labtech Notebook Software NB

1. **NB** (enter) Type this from any directory (a batch file in the root directory will handle this)
2. any key Press any key to continue
- 3a. **G** or cursor to "GO" (enter) Starts the data acquisition using the current setup
- OR**
- 3b1. **S** or cursor to "SETUP" (enter) Goes to the SETUP menu
- 3b2. **I** or cursor to "ICONview" (enter) Goes to the SETUP/ICONview screen showing the data acquisition ICONs
- 3b3. Mouse Click on **RUN** Starts the data acquisition using the current setup
4. **Esc** Stops the data acquisition and returns to the same screen as before acquisition was started
5. **G** or cursor to "GO" (enter) Start another session of data acquisition
- OR**
- Mouse Click on **RUN** Start another session from the SETUP ICONview screen
6. **Esc** Stops the data acquisition and returns to the same screen as before acquisition was started
7. **Esc** Goes to the QUIT/ANALYZE menu if not already there
- 8a. **Q** or cursor to "QUIT" (enter) QUIT the Labtech NB data acquisition program
- OR**
- 8b. **A** or cursor to "ANALYZE"(enter) Goes to the TF PLOT program for data analysis

NOTEBOOK SETUP - Using Labtech Notebook Software NB

1. **NB** (enter) Type this from any directory (a batch file in the root directory will handle this)
2. any key Press any key to continue
3. **S** or cursor to "SETUP" (enter) Goes to the SETUP menu
4. **I** or cursor to "ICONview" (enter) Goes to the SETUP/ICONview screen showing the data acquisition ICONs
5. Mouse Double-Click on the
1: ... ICON
(a file cabinet) Will give a screen showing the characteristics of the file storage parameters for the accelerations data.
6. **Cursor down to Data File Name** Allows a change to the file name into which the accelerations data is stored.
7. Type in **New FILE NAME** (enter) Makes a change to the file name; use the "&" to give of automatic numeric incrementing of file names each time a new data acquisition session is started: e.g. TURBOT&.BIN will enable creation of files TURBOTO.BIN, TURBOT2.BIN, etc.
8. **Esc** Returns to the ICONview screen
9. Mouse Double-Click on the
2: ... ICON
(a file cabinet) Will give a screen showing the characteristics of the file storage parameters for the GPS data.
10. **Cursor down to Data File Name** Allows a change to the file name into which the GPS data is stored.
11. Type in **New FILE NAME** (enter) Makes a change to the file name; use the "&" to give of automatic numeric incrementing of file names each time a new data acquisition session is started: e.g. TURBOT&.GPS will enable creation of files TURBOT1.GPS, TURBOT3.GPS, etc.
12. **Esc** Returns to the ICONview screen

GENERAL PROCEDURES - Using Labtech Notebook Software **NB** and **TFPLOT**

1. **NB** (enter) Type this from any directory (a batch file in the root directory will handle this)
2. any key Press any key to continue
3. **G** or cursor to
"GO" (enter) Start data acquisition
4. **Esc** Stops data acquisition and returns to QUIT menu
5. **Q** or cursor to
"QUIT" (enter) Quit the Labtech NB program

6. **FIXFILE RIDEO.BIN** (enter) Use the program FIXFILE to add the necessary sampling rate and number of channels to the data file
7. **TFPLOT** (enter) Run TFPLOT

