

NBSIR 84-2858

REPORT NO. 11
OBSERVATIONS OF THE APRIL 8, 1979
RAILROAD ACCIDENT AT CRESTVIEW,
FLORIDA

Charles G. Interrante
Samuel R. Low
James G. Early

U.S. DEPARTMENT OF COMMERCE
National Bureau of Standards
Center for Materials Science
Washington, DC 20234

David Dancer

Office of Rail Safety Research
Federal Railroad Administration
Department of Transportation
Washington, DC 20590

April 1984

Prepared for
Federal Railroad Administration
Department of Transportation
Washington, DC 20590



U.S. DEPARTMENT OF COMMERCE, Malcolm Baldrige, *Secretary*
NATIONAL BUREAU OF STANDARDS, Ernest Ambler, *Director*

TABLE OF CONTENTS

	<u>Page</u>
BACKGROUND	1
OBSERVATIONS	2
DOCUMENTATION	4
SUMMARY	4
INSPECTION REPORTS	7
NATX 34175	7
GATX 49258	8
GATX 47906	11
GATX 93444	12
GATX 55836	15
GATX 48505	17
GATX 47872	18
GATX 47878	22
GATX 47876	25
GATX 47834	27
GATX 47874	28
GATX 92097	29
GATX 44019	33
NATX 23367	42
ACFX 81395	46
ACFX 82959	55
ACFX 89990	65
GATX 5013	76

	<u>Page</u>
UTLX 28727	80
IMCX 2513	84
IMCX 2923	102
IMCX 2917	105
IMCX 2827	107
IMCX 2586	120
ACFX 18636	123
UTLX 77528	125
UTLX 40907	126
ACFX 89345	127
APPENDIX: TANK-CAR ACCIDENT DOCUMENTATION FORMS	128

Background

On April 8, 1979, 28 cars of a southbound freight train derailed 3.8 miles north of Crestview, Florida. The train [1] had departed Pensacola, Florida at 5:25 a.m. as No. 403, a second class freight train, consisting of five diesel-electric locomotive units, 107 loads, six empties, and a caboose, with a total weight of 11,360 tons. Shortly after 8:00 a.m. the 41st through the 68th car derailed (car number referenced from the first or lead locomotive). The 69th car came to rest at a bridge structure that became weakened from a fire and this led to the subsequent derailment of that car. Of the 29 cars that derailed, 28 were tank cars. Twenty six of the derailed tank cars contained hazardous materials; seventeen contained anhydrous ammonia, three contained acetone, four contained methanol, one contained chlorine and one contained carbolic acid. Two of the anhydrous ammonia cars ruptured and rocketed. The contents of the three cars of acetone and one car of methanol completely burned. One of the other methanol cars broke in half, and the contents completely burned. Six cars of anhydrous ammonia, one of chlorine, and one of carbolic acid developed leaks from various causes. A large cloud of vapor and smoke developed, blanketing the immediate area, eventually spreading over an area three to five miles wide. A schematic is shown in Figure 1 showing the locations of the derailed cars at the accident site as reported by the railroad.

[1] Railroad Accident Report, Louisville and Nashville Railroad, Crestview, Florida, April 8, 1979; U.S. Department of Transportation, Federal Railroad Administration, Office of Safety, May 1979.

In response to a request by the Federal Railroad Administration (FRA), personnel of the National Bureau of Standards (NBS) and of the FRA visited the site of this accident. The purpose of this visit was twofold. First, to make observations that could be useful in studies of the properties and behavior of railroad tank cars subject to abusive service conditions, such as those that occur in accidents of the types described above. Second, to select samples from damaged tank cars for use in later investigations at the NBS laboratory.

Observations

This report contains observations made on two separate visits to the vicinity of the accident site. The first of these two visits was made on April 19, 1979 by NBS investigators Dr. C.G. Interrante and Dr. J.G. Early and a representative from the FRA, Mr. D. Dancer. During this visit, extensive notes were taken of the conditions of the various cars that had been derailed and this was done at or nearby the site of the derailment. In addition, extensive photographs were taken to document the conditions of each of the derailed tank cars. Other observations included those of the path and orientation of fracture along with the mode of fracture for selected steel plates that were accessible. At that time, a total of twenty one plate samples were marked with NBS identifications. Some plates had two samples marked on them, such as samples 20A and 20B, for use in later investigations of the steels used in selected tank cars that had been damaged in service. For the derailed tank cars, Table 1 summarizes the information on tank car number, location within the train, DOT tank car class, NBS sample number, and the number of photographs taken.

During that first visit, each derailed tank car was observed and photographed, and special attention was given to all cars that had been severely damaged, either with large dents or fractures. Most of the cars had been repositioned from any original (derailed) sites at which they came to rest following the accident. Sketches were made of fractures that severed cars into two or more pieces and fracture path (direction) notations were made. **Notes were also taken** on all observations of dents and cracks or through thickness ruptures for all accessible parts of the cars. **Parts of some cars were inaccessible** because the air was still heavily laden with anhydrous ammonia fumes. Thus, close observation was made impossible for some fractured tank cars and work was halted.

The second visit was made by Dr. J.G. Early and Mr. S.R. Low of the NBS on May 8-9, 1979. By that date, the derailed cars had been loaded onto railroad flat cars and gondola cars and transported to a railroad siding. **Sketches and other** information taken during the first visit had been transferred onto worksheets that were designed specifically for selected types of information, as described later. These worksheets were completed during the second field visit. New data included measurements of plate thickness at various distances from selected fracture surfaces to determine the degree of plate thinning, as well as additional observations of fracture mode and appearance. **The latter were made** because some surfaces that were not exposed to view on the first visit were exposed after the cars had been moved.

Documentation

The information taken on tank cars is presented on special forms designed for this purpose. The principal form is titled "Inspection Report of a Tank Car Involved in an Accident". It gives the basic information on a tank car, such as DOT Class, commodity and mechanical information, as well as lists of any photographs taken of the car and a description of observations. This form is supplemented by photographs (where appropriate). Several other forms titled TANK-CAR ACCIDENT DOCUMENTATION, with various sub-titles: DAMAGE AND SAMPLES, FRACTURE PATH, FRACTURE MODE, and PLATE THINNING may be used to complete the documentation. These are forms used for 1) sketching the location and extent of damage or the location of samples, 2) sketching fracture paths, 3) sketching fracture modes, and 4) recording the extent of plate thinning near selected fractures. A sample of each of these types of data forms are given as an Appendix to this report. The forms contain information needed to minimize the ambiguity in interpretation of the data and observations presented on them and thus, are valuable aids for the subsequent metallurgical evaluation of the behavior of the materials of construction.

Summary

This report contains the results of the field investigation of the behavior and response of 28 tank cars which derailed on April 8, 1979 near Crestview, Florida. The pictorial representation of the damage to the cars as well as the field measurements and other data necessary for subsequent metallurgical evaluation of the materials of construction are reported on a series of prepared forms developed for field accident investigation.

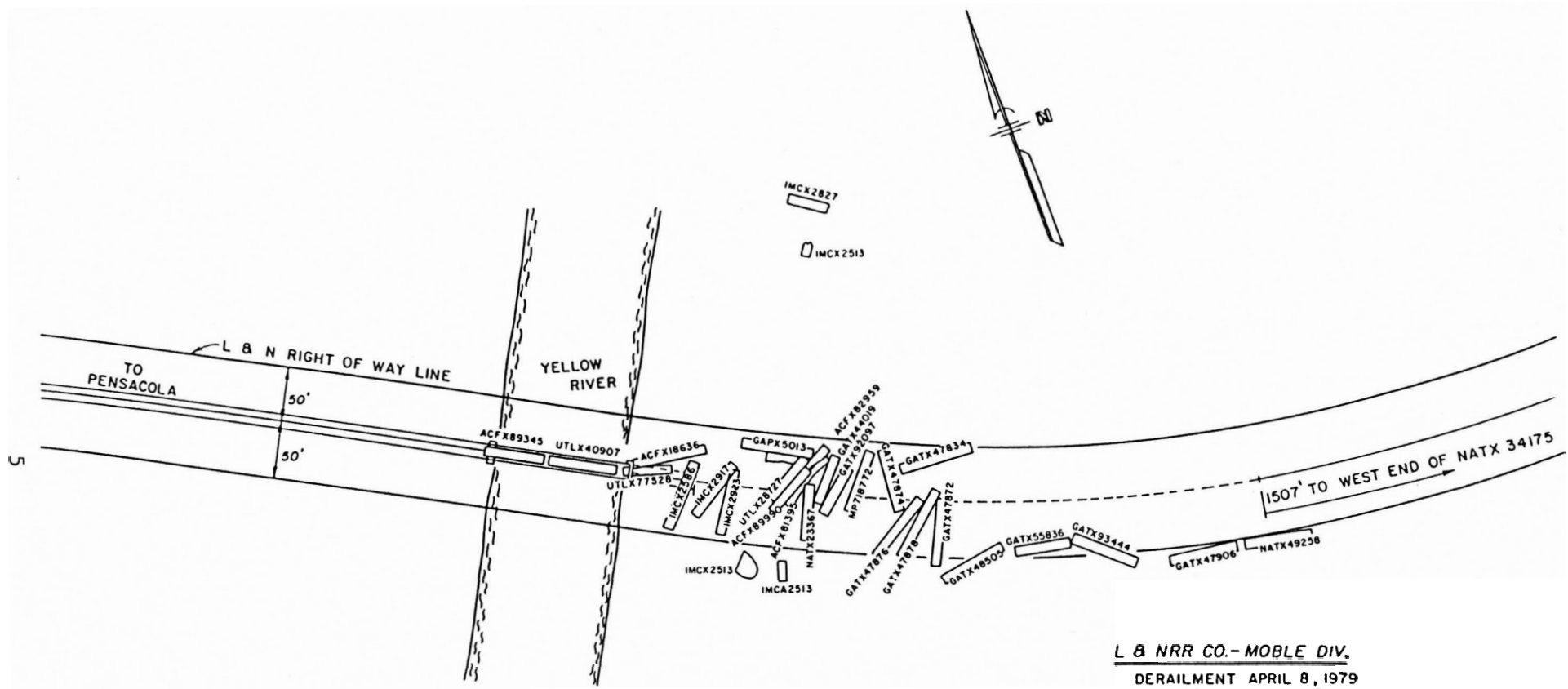

L & NRR CO.-MOBLE DIV.
DERAILMENT APRIL 8, 1979
AT 8:00 A.M. IN MILLIGAN,
FLA. SCALE 1"= 50'

Figure 1. The locations of the derailed cars at the accident site.

LOCATION IN TRAIN	TANK CAR DESIGNATION	NBS SAMPLE IDENTIFICATION	DOT CLASS	COMMODITY	NUMBER OF PHOTOS
41	NATX 34175	none	112S 340W	Anhydrous NH ₃	0
42	GATX 49258	none	105A 300W	Anhydrous NH ₃	3
43	GATX 47906	none	105A 300W	Anhydrous NH ₃	0
44	GATX 93444	none	112S 340W	Anhydrous NH ₃	4
45	GATX 55836	none	112A 340W	Anhydrous NH ₃	1
46	GATX 48505	none	105A 300W	Anhydrous NH ₃	0
47	GATX 47872	none	105A 300W	Anhydrous NH ₃	5
48	GATX 47878	none	105A 300W	Anhydrous NH ₃	4
49	GATX 47876	none	105A 300W	Anhydrous NH ₃	2
50	GATX 47834	none	105A 300W	Anhydrous NH ₃	0
51	GATX 47874	none	105A 300W	Anhydrous NH ₃	0
53	GATX 92097	none	111A 100W	Sulfur	5
54	GATX 44019	NBS 8	111A 100W	Drg Chem (Carbon Tetrachloride)	13
55	NATX 23367	NBS 14, 15 (both deleted)	111A 100W	Acetone	6
56	ACFX 81395	NBS 13, 13A	111A 100W	Acetone	11
57	ACFX 82959	NBS 18, 19	111A 100W	Acetone	13
58	ACFX 89990	NBS 6, 9, 10, 4	111A 100W	Methanol	11
59	GATX 5013	NBS 7	111A 100W	Methanol	2
60	UTLX 28727	NBS 20A, 20B	105A 300W	Chlorine	4
61	IMCX 2513	NBS 1, 2, 3, 16, 16A	112S 400W	Anhydrous NH ₃	19
62	IMCX 2923	none	105A 300W	Anhydrous NH ₃	3
63	IMCX 2917	none	105A 300W	Anhydrous NH ₃	2
64	IMCX 2827	NBS 11, 12, 17	105A 300W	Anhydrous NH ₃	14
65	IMCX 2586	none	112S 400W	Anhydrous NH ₃	2
66	ACFX 18636	NBS 5	112A 340W	Anhydrous NH ₃	1
67	UTLX 77528	none	111A 100W	Carbolic Acid	0
68	UTLX 40907	none	111A 100W1	Methanol	0
69	ACFX 89345	none	111A 100W1	Methanol	0

Table 1. Identity of twenty eight derailed tank cars.

Inspection Report of a Tank Car Involved in an Accident

Tank Car Number NATX 34175 and DOT Class 112 S 340W
Identification of Samples Taken From This Car _____
Inspection Date 4/19/79 and Location Milligan, Fla.
Accident Date 4/8/79 and Location Milligan, Fla.
Location in Train 41 Starting with Locomotive

Commodity Information: Loaded Empty _____
Commodity Anhydrous NH₃
Classification Non-Flammable gas

Mechanical Information: Continuous- _____ or Stub- _____ Sill
Type of Coupler Shell E
Head Shield: Yes No _____
Insulation: Yes _____ No _____

Identification of Photographs:

Black & White _____
Color _____

Exposure to Fire: None _____ or Describe: _____

Observations:

Jacket: No Jacket _____ or Describe: _____

Valves: _____

Shell and Head Plates: _____

(cont. on Attachment _____)

Sill, Coupler, Wheel, other parts (in that order) _____

(cont. on Attachment _____)

Inspection Report of a Tank Car Involved in an Accident

Tank Car Number GATX 49258 and DOT Class 105 A 300W
Identification of Samples Taken From This Car _____
Inspection Date 4/19/79 and Location Milligan, Fla.
Accident Date 4/8/79 and Location Milligan, Fla.
Location in Train 42 Starting with Locomotive

Commodity Information: Loaded Empty _____
Commodity Anhydrous NH₃
Classification Non-flammable gas

Mechanical Information: Continuous- _____ or Stub- _____ Sill
Type of Coupler F Type
Head Shield: Yes _____ No
Insulation: Yes No _____

Identification of Photographs:
Black & White 1-1, 1-2
Color C1-8

Exposure to Fire: None or Describe: _____

Observations:

Jacket: No Jacket _____ or Describe: Photos show badly wrinkled jacket with a fracture of 2 3/4 inches by 12 inches in the 7th course from the A head. No significant damage to jacket on either A or B-heads.

Valves: _____

Shell and Head Plates: Shell plates not observable.

(cont. on Attachment _____)

Sill, Coupler, Wheel, other parts (in that order) _____

(cont. on Attachment _____)



Photo 1-1: Tank-car GATX 49258 showing rumpled jacket and fracture in the 7th jacket course from the A head.



Photo 1-2: Close-up of 2 3/4 by 12 inches fracture in the 7th jacket course from the A head of tank-car GATX 49258.



Photo C1-8: Close-up of rumped jacket at the A end of tank-car GATX 49258.

Inspection Report of a Tank Car Involved in an Accident

Tank Car Number GATX 47906 and DOT Class 105A 300W

Identification of Samples Taken From This Car _____

Inspection Date 4/19/79 and Location Milligan, Fla.

Accident Date 4/8/79 and Location Milligan, Fla.

Location in Train 43 Starting with Locomotive

Commodity Information: Loaded X Empty _____

Commodity Anhydrous Ammonia

Classification Non-flammable gas

Mechanical Information: Continuous- _____ or Stub- _____ Sill

Type of Coupler F Type

Head Shield: Yes _____ No X

Insulation: Yes X No _____

Identification of Photographs:

Black & White _____

Color _____

Exposure to Fire: None X or Describe: _____

Observations:

Jacket: No Jacket _____ or Describe: Shell jacket rumpled. No significant damage to jacket on either the A or B-heads.

Valves: _____

Shell and Head Plates: _____

(cont. on Attachment _____)

Sill, Coupler, Wheel, other parts (in that order) _____

(cont. on Attachment _____)

Inspection Report of a Tank Car Involved in an Accident

Tank Car Number GATX 93444 and DOT Class 112 S 340W
Identification of Samples Taken From This Car _____
Inspection Date 4/19/79 and Location Milligan, Fla.
Accident Date 4/8/79 and Location Milligan, Fla.
Location in Train 44 Starting with Locomotive

Commodity Information: Loaded Empty _____
Commodity Anhydrous Ammonia
Classification Non-flammable gas

Mechanical Information: Continuous- _____ or Stub- _____ Sill
Type of Coupler Shelf E Type
Head Shield: Yes No _____
Insulation: Yes No _____

Identification of Photographs:
Black & White 2-2, 2-3, 2-4
Color C1-9

Exposure to Fire: None or Describe: _____

Observations:

Jacket: No Jacket _____ or Describe: Shell jacket was scratched but did not appear to be rumped. No significant damage to jacket on either A or B-heads. Head shield on B-head was dented.

Valves: _____

Shell and Head Plates: _____

(cont. on Attachment _____)

Sill, Coupler, Wheel, other parts (in that order) Head shield support pad (see 2-2) and head shield (2-3 and 2-4). Head shield was hit from one side with a gentle crushing force. Damage is shown in photos.

(cont. on Attachment _____)

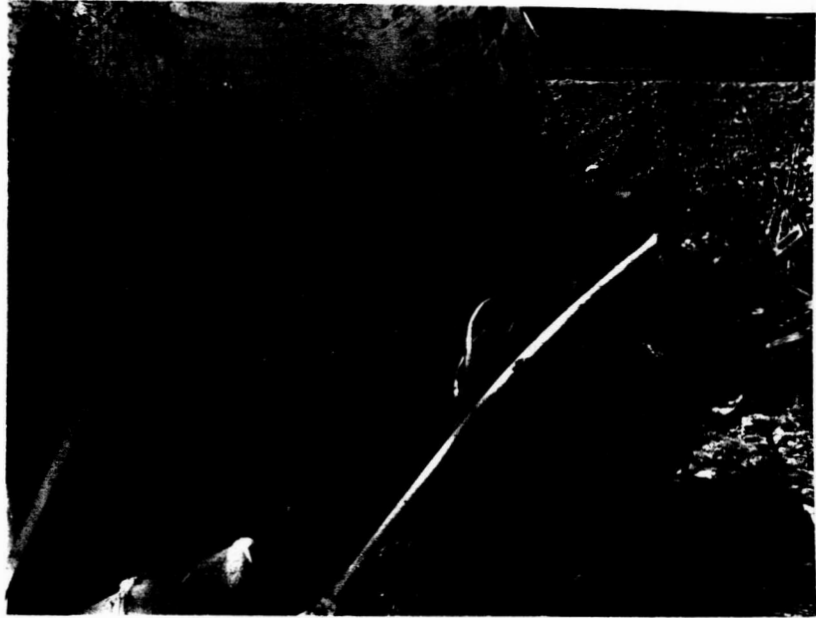

Photo 2-4: B head showing the head-shield of tank-car GATX 93444.



Photo 2-2: View of the area between the B head-plate and head-shield of tank-car GATX 93444.



Photo 2-3: B head showing the head-shield of tank-car GATX 93444.

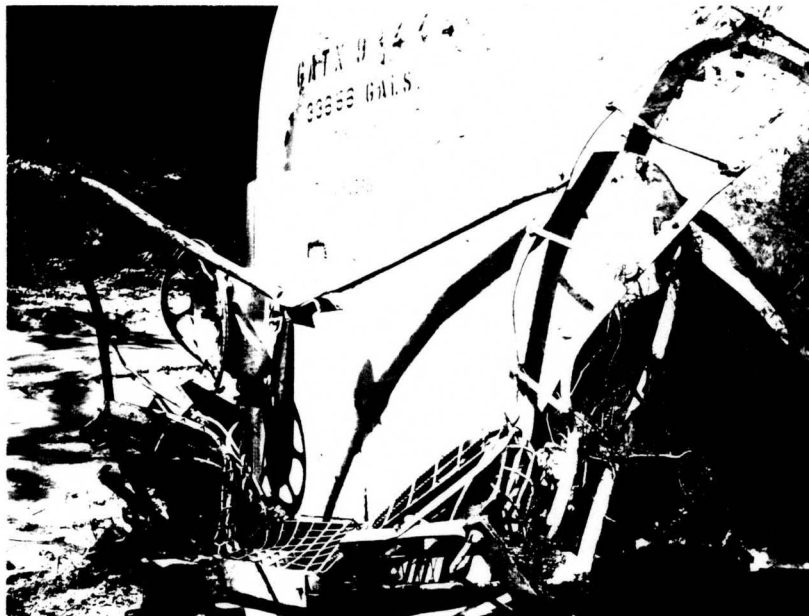

Photo C1-9: B head showing the head-shield of tank-car GATX 93444.

Inspection Report of a Tank Car Involved in an Accident

Tank Car Number GATX 55836 and DOT Class 112 A 340W

Identification of Samples Taken From This Car _____

Inspection Date 4/19/79 and Location Milligan, Fla.

Accident Date 4/8/79 and Location Milligan, Fla.

Location in Train 45 Starting with Locomotive

Commodity Information: Loaded X Empty _____

Commodity Anhydrous NH₃

Classification Non-flammable gas

Mechanical Information: Continuous- _____ or Stub- X Sill

Type of Coupler Shelf F Type

Head Shield: Yes _____ No X

Insulation: Yes X No _____

Identification of Photographs:

Black & White 1-4

Color _____

Exposure to Fire: None X or Describe: _____

Observations:

Jacket: No Jacket _____ or Describe: Scraped enough to remove paint and to scratch metal jacket, but was not rumped. No significant damage to jacket on either A or B-heads.

Valves: _____

Shell and Head Plates: _____

(cont. on Attachment _____)

Sill, Coupler, Wheel, other parts (in that order) _____

(cont. on Attachment _____)



Photo 1-4: B-end of tank-car GATX 55836.

Inspection Report of a Tank Car Involved in an Accident

Tank Car Number GATX 48505 and DOT Class 105 A 300W
Identification of Samples Taken From This Car _____
Inspection Date 4/19/79 and Location Milligan, Fla.
Accident Date 4/8/79 and Location Milligan, Fla.
Location in Train 46 Starting with Locomotive

Commodity Information: Loaded Empty _____
Commodity Anhydrous NH₃
Classification Non-flammable gas

Mechanical Information: Continuous- _____ or Stub- _____ Sill
Type of Coupler F Type
Head Shield: Yes _____ No
Insulation: Yes No _____

Identification of Photographs:

Black & White _____
Color _____

Exposure to Fire: None _____ or Describe: _____

Observations:

Jacket: No Jacket _____ or Describe: _____

Valves: _____

Shell and Head Plates: No significant damage to A-head.

(cont. on Attachment _____)

Sill, Coupler, Wheel, other parts (in that order) _____

(cont. on Attachment _____)

Inspection Report of a Tank Car Involved in an Accident

Tank Car Number GATX 47872 and DOT Class 105 A 300W
Identification of Samples Taken From This Car _____
Inspection Date 4/19/79 and Location Milligan, Fla.
Accident Date 4/8/79 and Location Milligan, Fla.
Location in Train 47 Starting with Locomotive

Commodity Information: Loaded Empty _____
Commodity Anhydrous NH₃
Classification Non-flammable gas

Mechanical Information: Continuous- _____ or Stub- _____ Sill
Type of Coupler F type
Head Shield: Yes _____ No
Insulation: Yes No _____

Identification of Photographs:

Black & White 1-6, 1-8
Color C1-10, C1-11, C1-14

Exposure to Fire: None or Describe: _____

Observations:

Jacket: No Jacket _____ or Describe: Dented and scratched. No significant damage to A-head jacket. B-head jacket has several dents. Shell jacket torn, but no visible shell damage.

Valves: _____

Shell and Head Plates: Unobservable.

(cont. on Attachment _____)

Sill, Coupler, Wheel, other parts (in that order) _____

(cont. on Attachment _____)



Photo 1-6: Tank-cars GATX 47872 (left) and GATX 47878 (right).



Photo 1-8: Tank-cars GATX 47872 (left) and GATX 47878 (right).



Photo Cl-10: B-end of tank-car GATX 47872.



Photo Cl-11: B-end of tank-car GATX 47872.

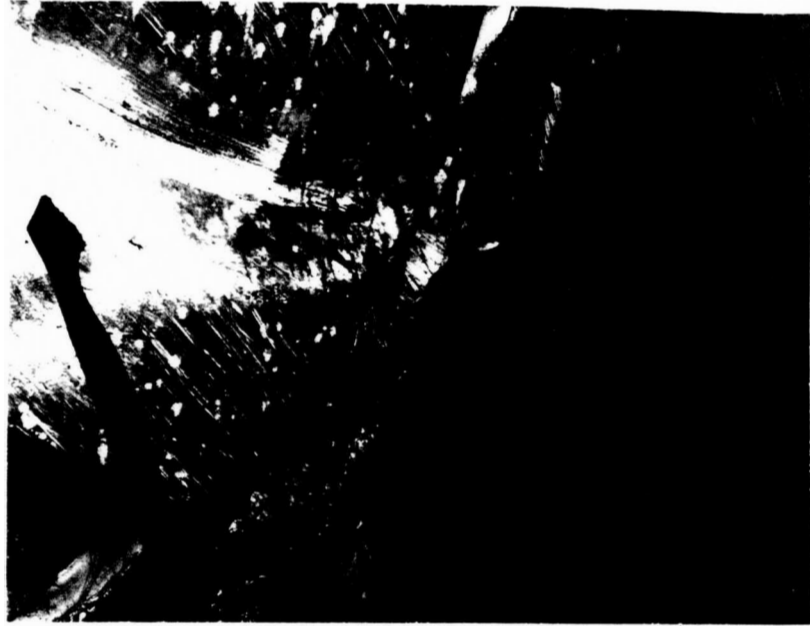

Photo C1-14: Tank-car 47872.

Inspection Report of a Tank Car Involved in an Accident

Tank Car Number GATX 47878 and DOT Class 105 A 300W

Identification of Samples Taken From This Car _____

Inspection Date 4/19/79 and Location Milligan, Fla.

Accident Date 4/8/79 and Location Milligan, Fla.

Location in Train 48 Starting with Locomotive

Commodity Information: Loaded Empty _____

Commodity Anhydrous NH₃

Classification Non-flammable gas

Mechanical Information: Continuous- _____ or Stub- _____ Sill

Type of Coupler F Type

Head Shield: Yes _____ No

Insulation: Yes No _____

Identification of Photographs:

Black & White 1-6, 1-7, 1-8, and 1-8B

Color _____

Exposure to Fire: None or Describe: _____

Observations:

Jacket: No Jacket _____ or Describe: Dented and scratched, and ruptured (see 1-8 and 1-8B) in head (small) and shell area (larger).

Valves: _____

Shell and Head Plates: Unobservable

(cont. on Attachment _____)

Sill, Coupler, Wheel, other parts (in that order) _____

(cont. on Attachment _____)



Photo 1-8: Tank-cars GATX 47878 (right) and GATX 47872 (left).



Photo 1-6: Tank-cars GATX 47878 (right) and GATX 47872 (left).

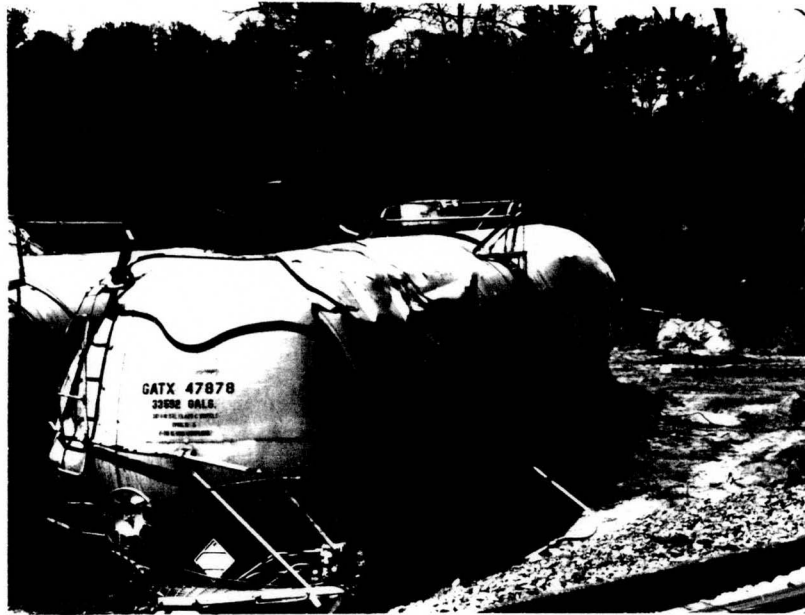

Photo 1-7: Tank-car GATX 47878.



Photo 1-8B: Torn jacket in tank-car GATX 47878.

Inspection Report of a Tank Car Involved in an Accident

Tank Car Number GATX 47876 and DOT Class 105 A 300W

Identification of Samples Taken From This Car _____

Inspection Date 4/19/79 and Location Milligan, Fla.

Accident Date 4/8/79 and Location Milligan, Fla.

Location in Train 49 Starting with Locomotive

Commodity Information: Loaded X Empty _____

Commodity Anhydrous NH₃

Classification Non-flammable gas

Mechanical Information: Continuous- _____ or Stub- _____ Sill

Type of Coupler F Type

Head Shield: Yes _____ No X

Insulation: Yes X No _____

Identification of Photographs:

Black & White 1-9

Color C1-13

Exposure to Fire: None _____ or Describe: _____

Observations:

Jacket: No Jacket _____ or Describe: Damaged at one end. Both A and B-heads jackets have dents at edge.

Valves: _____

Shell and Head Plates: No apparent damage.

(cont. on Attachment _____)

Sill, Coupler, Wheel, other parts (in that order) _____

(cont. on Attachment _____)

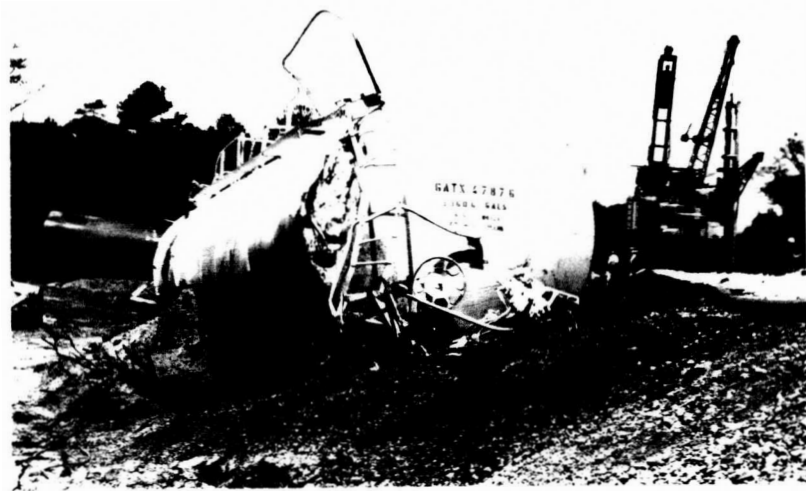

Photo 1-9: B head of tank-car GATX 47876.

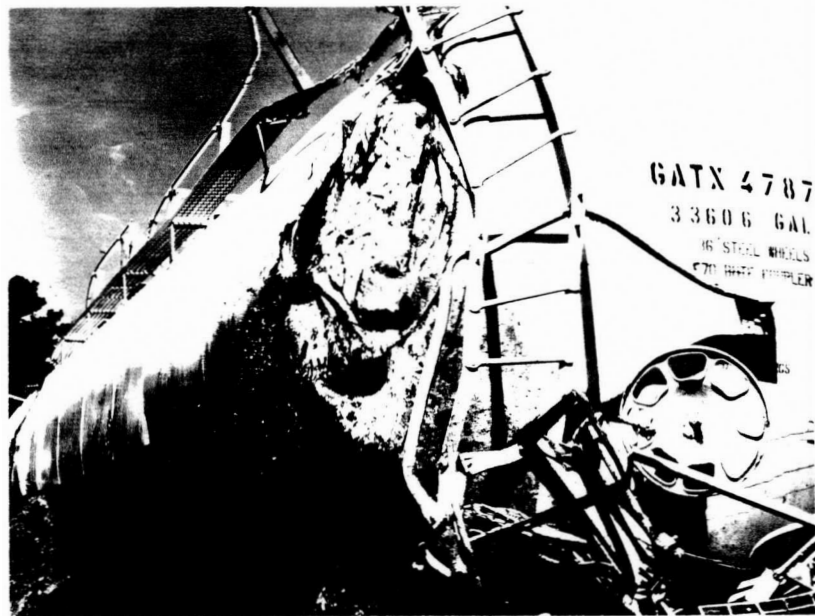

Photo C1-13. Closer view of the B head of tank-car GATX 47876.

Inspection Report of a Tank Car Involved in an Accident

Tank Car Number GATX 47834 and DOT Class 105 A 300W

Identification of Samples Taken From This Car _____

Inspection Date 4/19/79 and Location Milligan, Fla.

Accident Date 4/8/79 and Location Milligan, Fla.

Location in Train 50 Starting with Locomotive

Commodity Information: Loaded X Empty _____

Commodity Anhydrous NH₃

Classification Non-flammable gas

Mechanical Information: Continuous- _____ or Stub- _____ Sill

Type of Coupler F Type

Head Shield: Yes _____ No X

Insulation: Yes X No _____

Identification of Photographs:

Black & White _____

Color _____

Exposure to Fire: None _____ or Describe: _____

Observations:

Jacket: No Jacket _____ or Describe: _____

Valves: _____

Shell and Head Plates: _____

(cont. on Attachment _____)

Sill, Coupler, Wheel, other parts (in that order) _____

(cont. on Attachment _____)

Inspection Report of a Tank Car Involved in an Accident

Tank Car Number GATX 47874 and DOT Class 105 A 300W

Identification of Samples Taken From This Car _____

Inspection Date 4/19/79 and Location Milligan, Fla.

Accident Date 4/8/79 and Location Milligan, Fla.

Location in Train 51 Starting with Locomotive

Commodity Information: Loaded Empty _____

Commodity Anhydrous NH₃

Classification Non-flammable gas

Mechanical Information: Continuous- _____ or Stub- _____ Sill

Type of Coupler F Type

Head Shield: Yes _____ No

Insulation: Yes No _____

Identification of Photographs:

Black & White _____

Color _____

Exposure to Fire: None _____ or Describe: _____

Observations:

Jacket: No Jacket _____ or Describe: _____

Valves: _____

Shell and Head Plates: _____

(cont. on Attachment _____)

Sill, Coupler, Wheel, other parts (in that order) _____

(cont. on Attachment _____)

Inspection Report of a Tank Car Involved in an Accident

Tank Car Number GATX 92097 and DOT Class 111A 100W
Identification of Samples Taken From This Car _____
Inspection Date 4/19/79 and Location Milligan, Fla.
Accident Date 4/8/79 and Location Milligan, Fla.
Location in Train 53 Starting with Locomotive

Commodity Information: Loaded Empty _____
Commodity Sulfur
Classification Not regulated

Mechanical Information: Continuous- _____ or Stub- _____ Sill
Type of Coupler E Type
Head Shield: Yes _____ No
Insulation: Yes No _____

Identification of Photographs:
Black & White 1-10, 1-11
Color C1-17, C1-18, C2-1

Exposure to Fire: None _____ or Describe: _____

Observations:

Jacket: No Jacket _____ or Describe: Badly damaged. Severe dents in both A and B-heads.

Valves: _____

Shell and Head Plates: Both A and B-head plates had dents at edge.

(cont. on Attachment _____)

Sill, Coupler, Wheel, other parts (in that order) This car had journal bearings and it is the only one on the train equipped this way.

(cont. on Attachment _____)



Photo 1-10: A-head of tank-car GATX 92097.



Photo 1-11: A-head of tank-car GATX 92097.



Photo C1-17: A-end of tank-car GATX 92097.



Photo C1-18: B-end of tank-car GATX 92097.



Photo C2-1: B head of tank-car GATX 92097.

Inspection Report of a Tank Car Involved in an Accident

Tank Car Number GATX 44019 and DOT Class 111A 100W
Identification of Samples Taken From This Car NBS 8
Inspection Date 4/19/79 and Location Milligan, Fla.
Accident Date 4/8/79 and Location Milligan, Fla.
Location in Train 54 Starting with Locomotive

Commodity Information: Loaded Empty _____
Commodity Drg Chem (Carbon Tetrachloride)
Classification ORM-A

Mechanical Information: Continuous- _____ or Stub- _____ Sill
Type of Coupler F Type
Head Shield: Yes _____ No
Insulation: Yes _____ No

Identification of Photographs:
Black & White 1-16 to 1-22, 2-5, 2-6
Color C2-3, C2-4, C2-5, C2-6

Exposure to Fire: None _____ or Describe: One end of car had paint removed due to fire.

Observations:
Jacket: No Jacket or Describe: _____

Valves: _____

Shell and Head Plates: This very badly damaged car had only one fracture (in course 4). It was 17" long in a shell plate at a region of very high strain. NBS 8 contains course 4 and the weld to 3. The A-head contained a dent at the edge. (cont. on Attachment _____)

Sill, Coupler, Wheel, other parts (in that order) _____

(cont. on Attachment _____)

TANK-CAR ACCIDENT DOCUMENTATION
(DAMAGE AND SAMPLES)

Tank-Car Number GATX 44019
 Documented by S. Low / J. Early
 Date 5/8/79 and Location Railroad Siding, Pensacola Bay, Fla.

LOCATIONS OF SHELL COURSES, FRACTURES AND SAMPLES

(All views are from the outside of the tank car and fracture paths are indicated by dashed lines.)

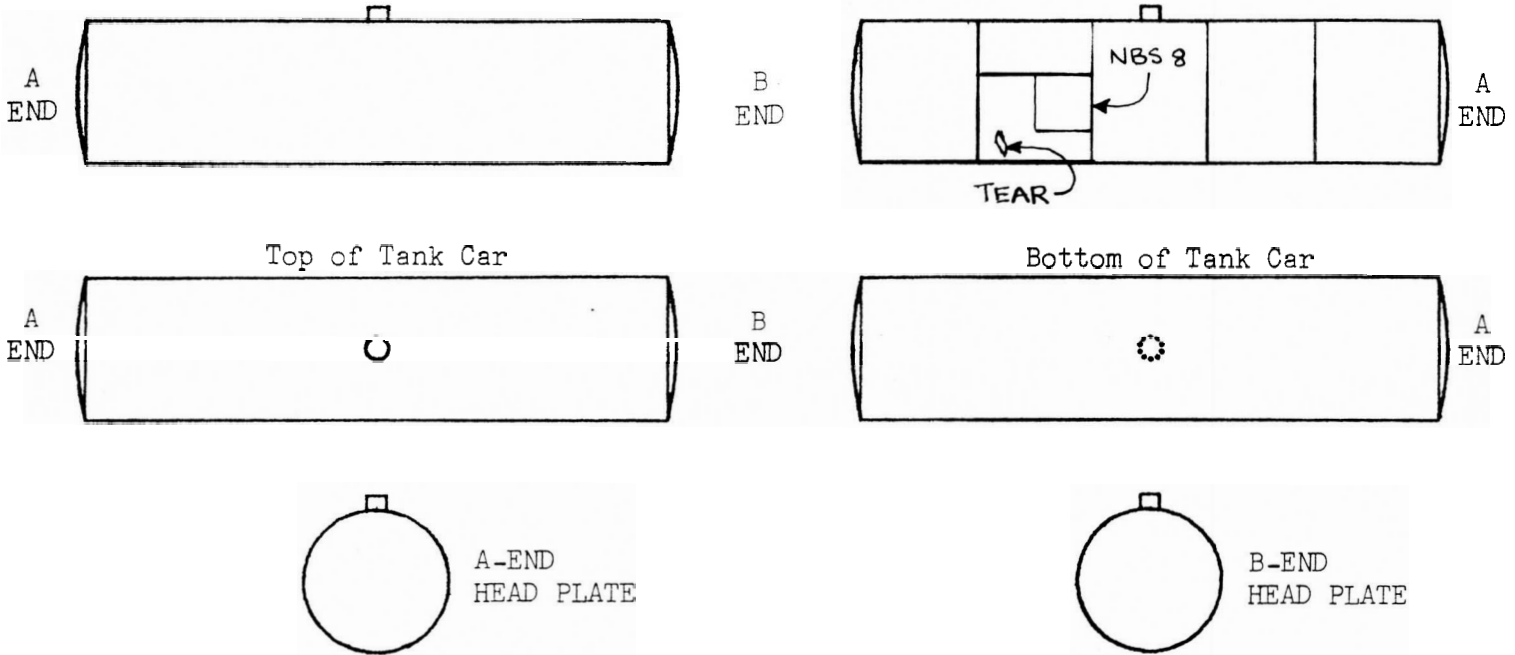

SAMPLE IDENTIFICATION NUMBER	OTHER SAMPLE IDENTIFICATION MARKINGS	LOCATION OF SAMPLE ON CAR
NBS 8		Shell course 4.



Photo 1-16: Tank-car GATX 44019 showing a 17 inch fracture.



Photo 1-17: Tank-car GATX 44019 showing a 17 inch fracture.



Photo 2-6: Tank-car GATX 44019 showing a 17 inch fracture.

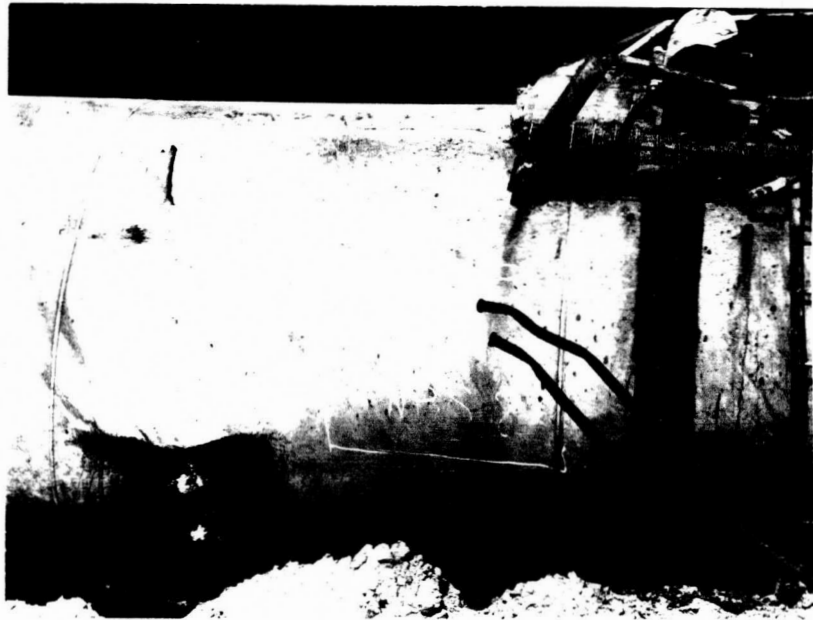

Photo 2-5: Tank-car 44019 showing a closer view of a 17 inch fracture.



Photo 1-18: Close-up of a 17 inch fracture in tank-car GATX 44019.



Photo 1-19: Close-up of a 17 inch fracture in tank-car GATX 44019.



Photo C2-3: Close-up of a 17 inch fracture in tank-car GATX 44019.

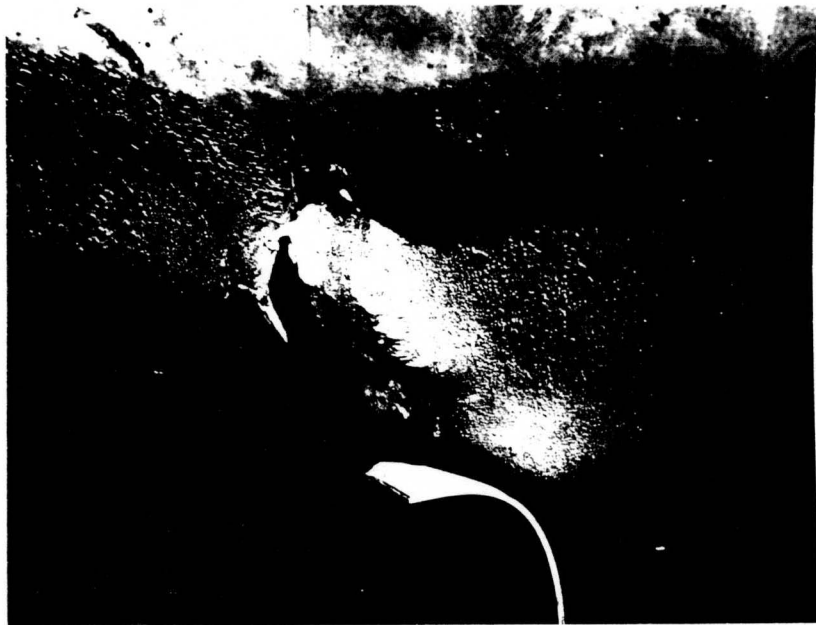

Photo C2-5: Close-up of a 17 inch fracture in tank-car GATX 44019.



Photo 1-22: A-head of tank-car GATX 44019.



Photo 1-21: A-head of tank-car GATX 44019.



Photo C2-6: Close-up view of the A-head of tank-car GATX 44019.

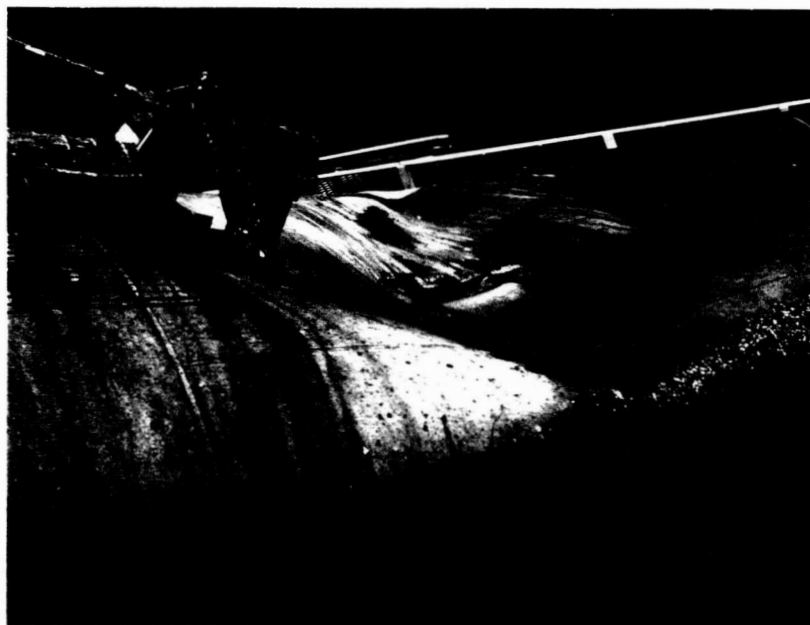

Photo C2-4: Large dent in the top of tank-car GATX 44019.

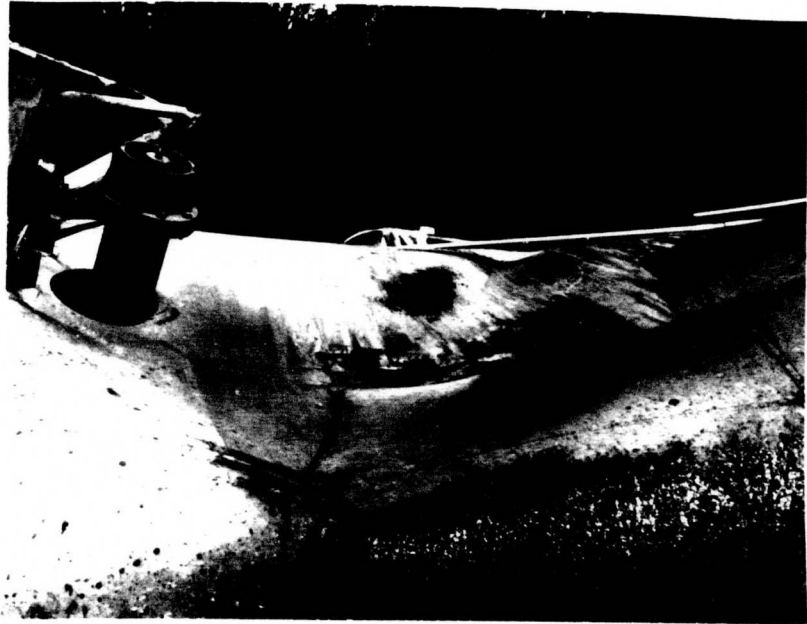

Photo 1-20: Large dent in the top of tank-car
GATX 44019.

Inspection Report of a Tank Car Involved in an Accident

Tank Car Number NATX 23367 and DOT Class 111A 100W
Identification of Samples Taken From This Car NBS 14, 15 both deleted
Inspection Date 4/19/79 and Location Milligan, Fla.
Accident Date 4/8/79 and Location Milligan, Fla.
Location in Train 55 Starting with Locomotive

Commodity Information: Loaded Empty _____
Commodity Acetone
Classification Flammable liquid

Mechanical Information: Continuous- _____ or Stub- _____ Sill
Type of Coupler E Type
Head Shield: Yes _____ No
Insulation: Yes _____ No

Identification of Photographs:
Black & White 2-20, 2-21, 2-22
Color C3-11, C5-11, C5-12

Exposure to Fire: None _____ or Describe: Totally engulfed.

Observations:
Jacket: No Jacket or Describe: _____

Valves: _____

Shell and Head Plates: NBS 14 and 15 which contained badly damaged shell courses that took much abuse, had to be deleted (for economic reasons) from the list of sample plates taken for use at NBS. The samples were in relatively undeformed parts of these shell courses. B-head contains no significant damage. (cont. on Attachment _____)

Sill, Coupler, Wheel, other parts (in that order) _____

(cont. on Attachment _____)



Photo 2-21: B-end of tank-car NATX 23367.



Photo C3-11: B-end of tank-car NATX 23367.



Photo C5-12: B-end of tank-car NATX 23367.



Photo C5-11: Crushed area of tank-car NATX 23367.



Photo 2-20: Crushed area of tank-car NATX 23367.



Photo 2-22: Close-up of a relatively undeformed area of badly damaged shell courses of tank-car NATX 23367.

Inspection Report of a Tank Car Involved in an Accident

Tank Car Number ACFX 81395 as marked
in crayon on car. and DOT Class 111A 100W
Identification of Samples Taken From This Car NBS 13 and 13A
Inspection Date 4/19/79 and Location Milligan, Fla.
Accident Date 4/8/79 and Location Milligan, Fla.
Location in Train 56 Starting with Locomotive

Commodity Information: Loaded Empty _____
Commodity Acetone
Classification Flammable liquid

Mechanical Information: Continuous- or Stub- _____ Sill
Type of Coupler E Type
Head Shield: Yes _____ No
Insulation: Yes _____ No

Identification of Photographs:

Black & White 2-15, 2-16, 2-32, 2-18 and 2-19
Color C3-14, C5-5, C5-6, C5-7, C5-9, C5-10

Exposure to Fire: None _____ or Describe: _____

Observations:

Jacket: No Jacket _____ or Describe: _____

Valves: _____

Shell and Head Plates: Car leaked its contents from fractures. Fractures
were observed on top and on bottom where a 2-ft. long fracture (see 2-15)
exists in the course that contains the relief (cont. on Attachment A)

Sill, Coupler, Wheel, other parts (in that order) Sill is crumpled
by a huge blow from below.

(cont. on Attachment _____)

A ACFX 81395

valve (course 3). On top of 63" fracture is largest flaw.

The tank has a banana shape. The 63" rupture is generally lying in the girth weld direction away from the girth weld.

NBS 13 is located in two shell courses (one contains 63" rupture); NBS 13A is located in the severely dented head plate, but it is in a relatively undeformed part of this head plate.

TANK-CAR ACCIDENT DOCUMENTATION
(DAMAGE AND SAMPLES)

Tank-Car Number ACFX 81395
 Documented by S. Low / J. Early
 Date 5/8/79 and Location Railroad Siding, Pensacola Bay, Fla.

LOCATIONS OF SHELL COURSES, FRACTURES AND SAMPLES

(All views are from the outside of the tank car and fracture paths are indicated by dashed lines.)

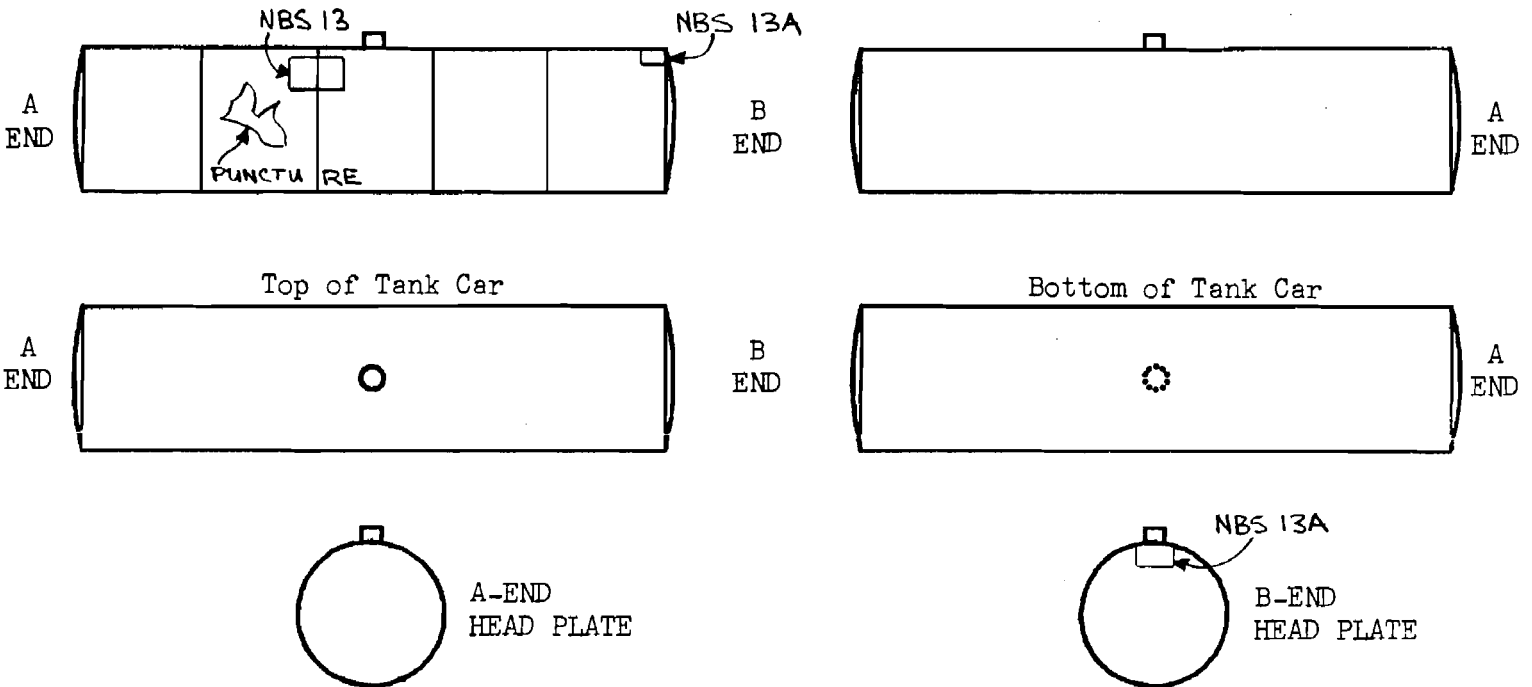

SAMPLE IDENTIFICATION NUMBER	OTHER SAMPLE IDENTIFICATION MARKINGS	LOCATION OF SAMPLE ON CAR
NBS 13		Shell courses 2 & 3, near puncture.
NBS 13A		Shell course 5 & B-head plate.



Photo 2-16: Tank-car ACFX 81395.



Photo C3-14: Tank-car ACFX 81395.



Photo 2-32: Tank-car ACFX 81395.



Photo C5-6: Crushed and fractured area of tank-car ACFX 81395 showing sample NBS 13.



Photo C5-5: Closer view of a crushed and fractured area of tank-car ACFX 81395 showing NBS 13.



Photo 2-18: Tank-car ACFX 81395 showing a fractured shell.

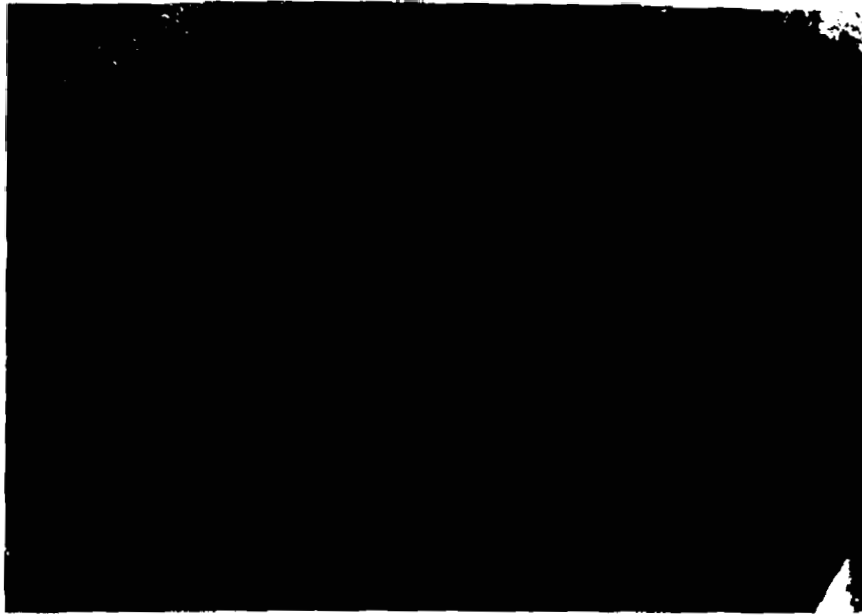

Photo C5-10: Huge dent in the B-head-plate of tank-car ACFX 81395. This headplate also contains NBS 13A (not shown).



Photo C5-7: Badly dented A-head-plate of tank-car ACFX 81395.

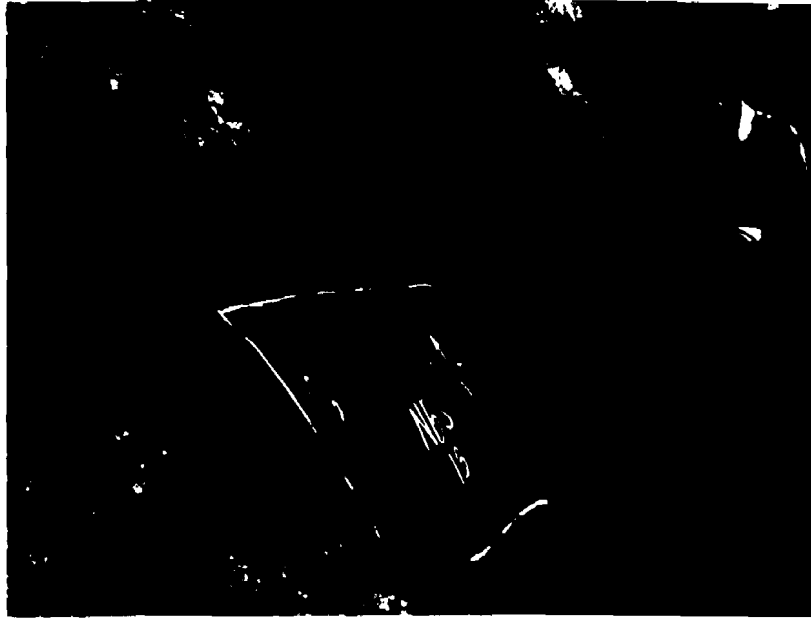

Photo 2-19: Close-up of sample NBS 13 marked adjacent to a fracture in tank-car ACFX 81395.



Photo C5-9: Close-up of sample NBS 13A marked on the B-head-plate of tank-car ACFX 81395.

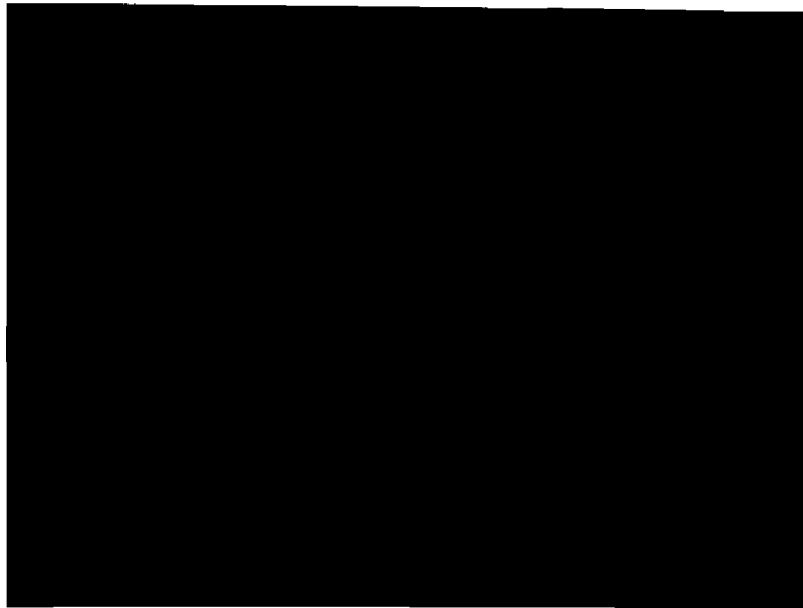

Photo 2-15: Area at bottom of tank-car ACFX 81395 showing a 2 foot long fracture.

Inspection Report of a Tank Car Involved in an Accident

Tank Car Number ACFX 82959 and DOT Class 111A 100W
Identification of Samples Taken From This Car NBS 18, 19
Inspection Date 4/19/79 and Location Milligan, Fla.
Accident Date 4/8/79 and Location Milligan, Fla.
Location in Train 57 Starting with Locomotive

Commodity Information: Loaded Empty
Commodity Acetone
Classification Flammable liquid

Mechanical Information: Continuous- or Stub- Sill
Type of Coupler E Type
Head Shield: Yes No
Insulation: Yes No

Identification of Photographs:

Black & White 2-26, 2-27, 2-28, 2-29, 2-30, 2-31
Color C3-19, C3-12, C4-21, C4-22, C5-2, C5-3, C5-4

Exposure to Fire: None or Describe: Severe exposure to fire.

Observations:

Jacket: No Jacket or Describe: _____

Valves: Valve dome partially ripped from shell course.

Shell and Head Plates: A most badly damaged and crushed car that did contain stable fractures (see photo 2-26). Sample NBS 18 was taken (see photo 2-30) in an unaffected (not deformed) (cont. on Attachment A) Sill, Coupler, Wheel, other parts (in that order) _____

(cont. on Attachment _____)

A ACFX 82959

part of a head plate that contained a 10-inch long, through-the-thickness, stable flaw. The balance of this sample is the adjoining shell course.

At the other end of this car (see photos 2-29 and 2-31) in the last shell course, was a flaw of >3 feet in length, and in the head at that end were flaws of 5 and 6 feet in length. This shell and this head are contained in sample NBS 19.

NBS 18 included more of this head plate.

TANK-CAR ACCIDENT DOCUMENTATION
(DAMAGE AND SAMPLES)

Tank-Car Number ACFX 82959
 Documented by S. Low / J. Early
 Date 5/8/79 and Location Railroad Siding, Pensacola Bay, Fla.

LOCATIONS OF SHELL COURSES, FRACTURES AND SAMPLES

(All views are from the outside of the tank car and fracture paths are indicated by dashed lines.)

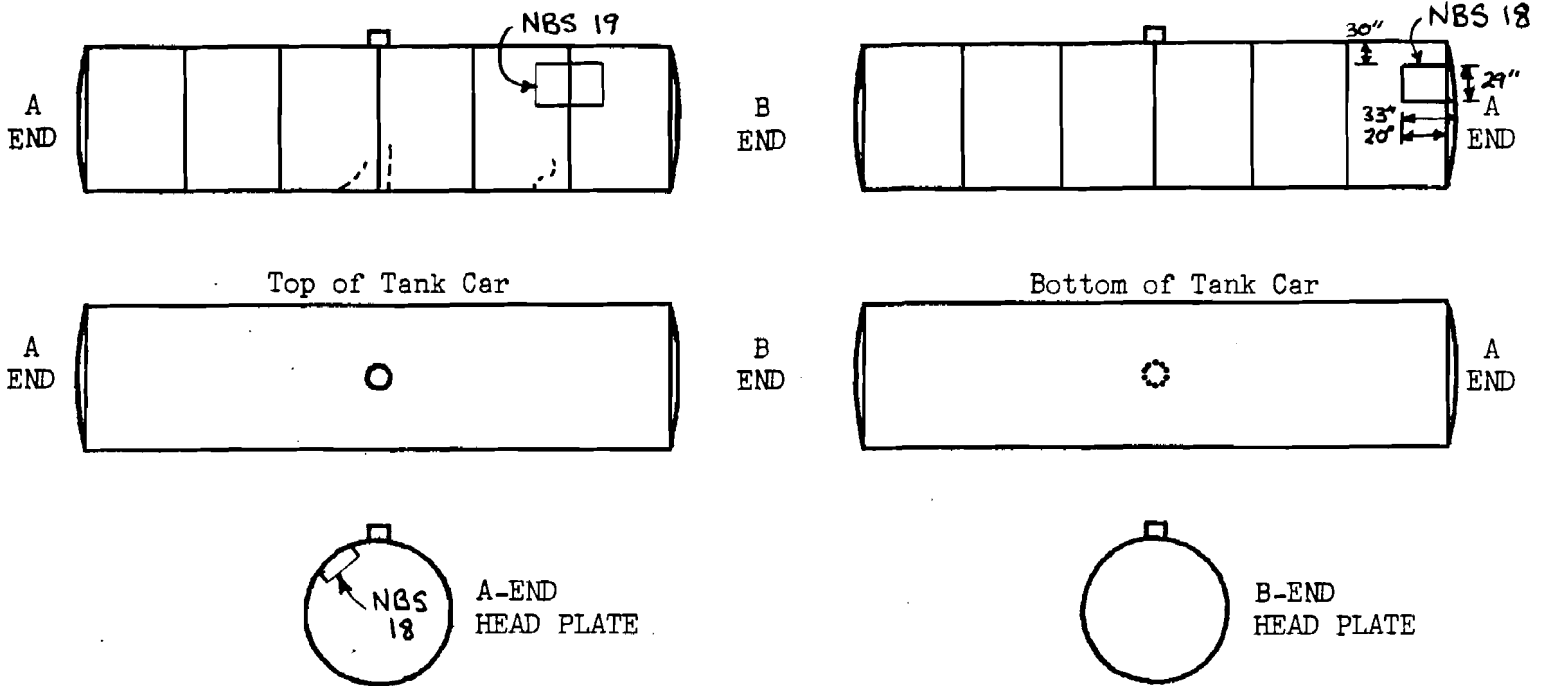

SAMPLE IDENTIFICATION NUMBER	OTHER SAMPLE IDENTIFICATION MARKINGS	LOCATION OF SAMPLE ON CAR
NBS 18		Shell course 1 and A-head plate.
NBS 19		Shell courses 5 & 6.



photo C3-12: A-end of tank-car ACFX 82959 (left) and tank-car IMCX 2827 (right).



Photo 2-27: A-end of tank-car ACFX 82959.

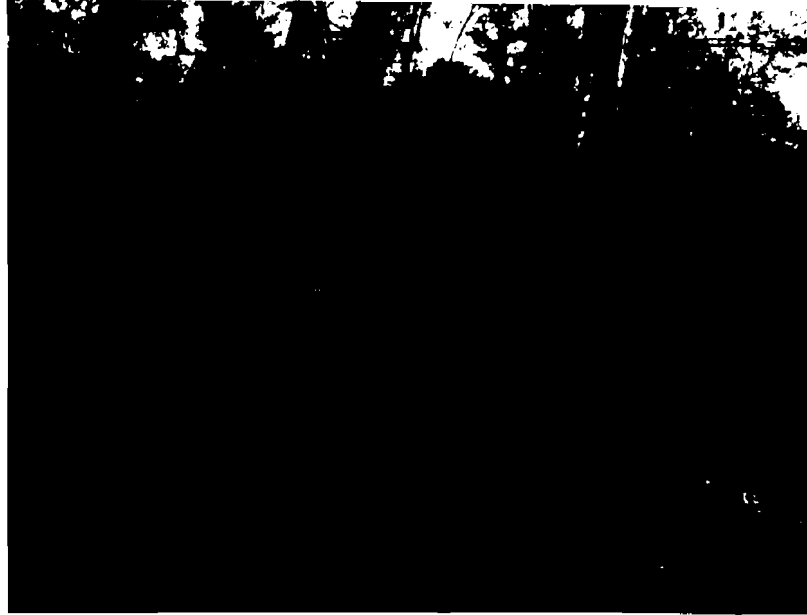

Photo 2-31: B-end of tank-car ACFX 82959 showing crushed shells and sample NBS 19.



Photo C4-22: B-end of tank-car ACFX 82959 showing sample NBS 19.



Photo 2-28: Top of tank-car ACFX 82959 showing valve area torn open.



Photo 2-29: Sill area at the B-end of tank-car ACFX 82959.

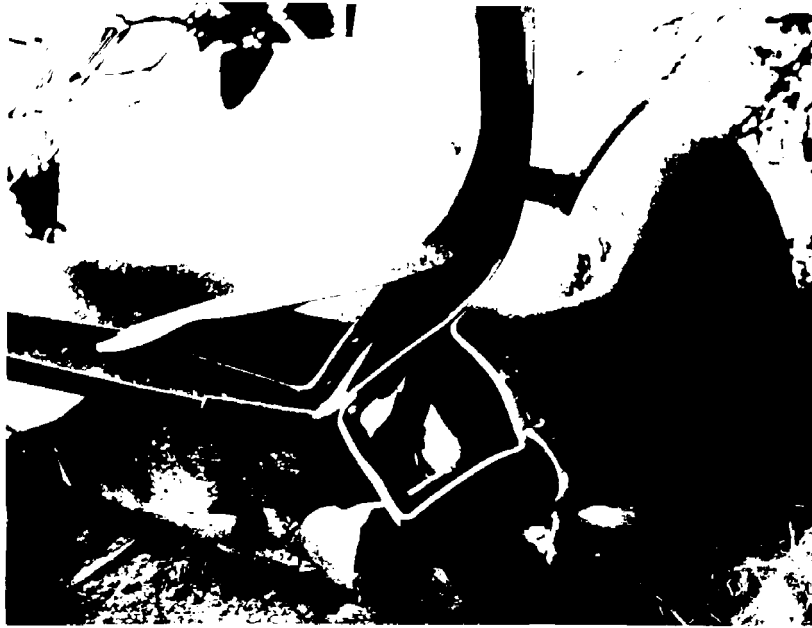

Photo C3-19: B-end of tank-car ACFX 82959 showing a large hole at the end of the car.



Photo C5-2: Tank-car ACFX 82959 showing a large hole torn open.



Photo C4-21: B-end of tank-car ACFX 82959 showing a 24 inch fracture.



Photo 2-26. A-head of tank-car ACFX 82959 showing a huge dent.



Photo 2-30: A-end of tank-car ACFX 82959 showing a huge dent and sample NBS 18.



Photo C5-4: A-end of tank-car ACFX 82959 showing a large dent in the car side and sample NBS 18.



Photo C5-3: A-head of tank-car ACFX 82959 showing a huge dent.

Inspection Report of a Tank Car Involved in an Accident

Tank Car Number ACFX 89990 and DOT Class 111A 100W
Identification of Samples Taken From This Car NBS 6, 9, 10, and 4.
Inspection Date 4/19/79 and Location Milligan, Fla.
Accident Date 4/8/79 and Location Milligan, Fla.
Location in Train 58 Starting with Locomotive

Commodity Information: Loaded X Empty _____
Commodity Methanol
Classification Flammable liquid

Mechanical Information: Continuous- _____ or Stub- _____ Sill _____
Type of Coupler F Type
Head Shield: Yes _____ No X
Insulation: Yes _____ No X

Identification of Photographs:

Black & White 2-9, 2-10
Color C2-14, C2-15, C2-16, C2-17, C2-20, C4-13, C4-14, C4-15, C4-16

Exposure to Fire: None _____ or Describe: Severe exposure over entire tank.

Observations:

Jacket: No Jacket X or Describe: _____

Valves: NBS 6 is safety vent valve.

Shell and Head Plates: Failed circumferentially into two parts: one was badly flattened and contained NBS 6. The other contained NBS 4 on a badly damaged, but not fractured head, as (cont. on Attachment A)
Sill, Coupler, Wheel, other parts (in that order) _____

(cont. on Attachment _____)

A ACFX 89990

well as NBS 9 and 10 taken from SC 4.

The tub containing the B-head was generally intact, although deformed so that it no longer is a cross-section of a cylinder. The B-head itself exhibited a massive dent at one edge, but no sign of rupture. The tub containing the A-head was severely flattened with numerous ruptures, along girth welds (between the head and shell plate and between shell plates).

TANK-CAR ACCIDENT DOCUMENTATION
(DAMAGE AND SAMPLES)

Tank-Car Number ACFX 89990
 Documented by S. Low / J. Early
 Date 5/8/79 and Location Railroad Siding, Pensacola Bay, Fla.

LOCATIONS OF SHELL COURSES, FRACTURES AND SAMPLES

(All views are from the outside of the tank car and fracture paths are indicated by dashed lines.)

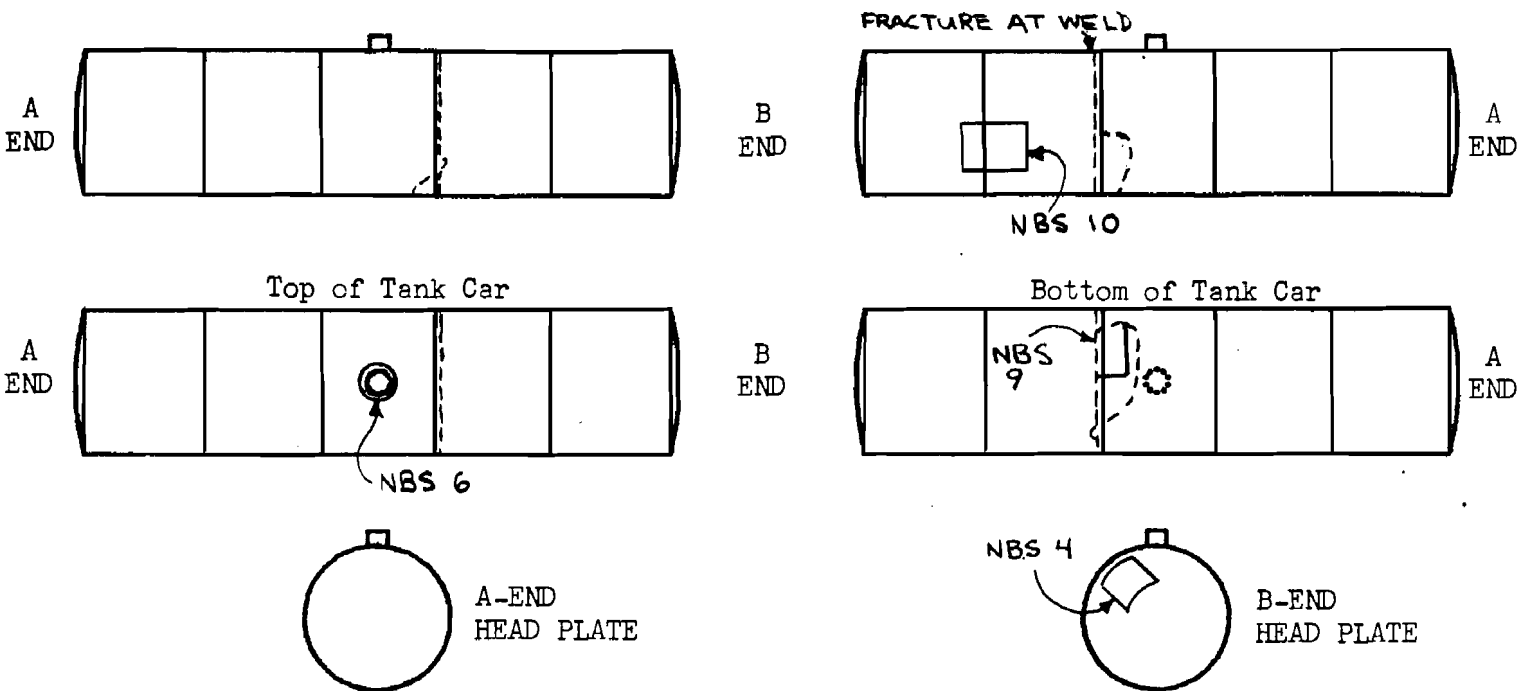

SAMPLE IDENTIFICATION NUMBER	OTHER SAMPLE IDENTIFICATION MARKINGS	LOCATION OF SAMPLE ON CAR
NBS 4		B-end Head Plate.
NBS 6		Valve.
NBS 9		Shell course 3, at end of tab.
NBS 10		Shell courses 4 & 5.

TANK-CAR ACCIDENT DOCUMENTATION

(FRACTURE PATH)

Tank-Car Number ACFX 89990

Documented by S. Low

Date 5/8/79 and Location Railroad Siding, Pensacola Bay, Fla.

SHELL COURSES AND THIS FRACTURE LOCATION

All time references are made for viewing from the A-End to the B-End of the tank car.

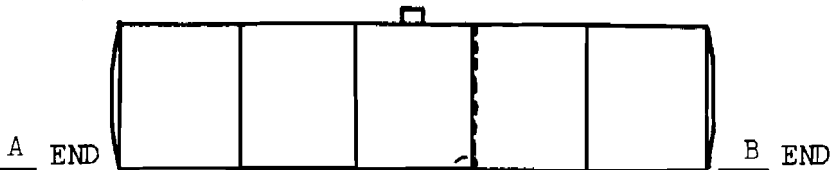
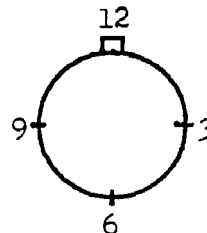

(This view is from the outside of the tank car.)

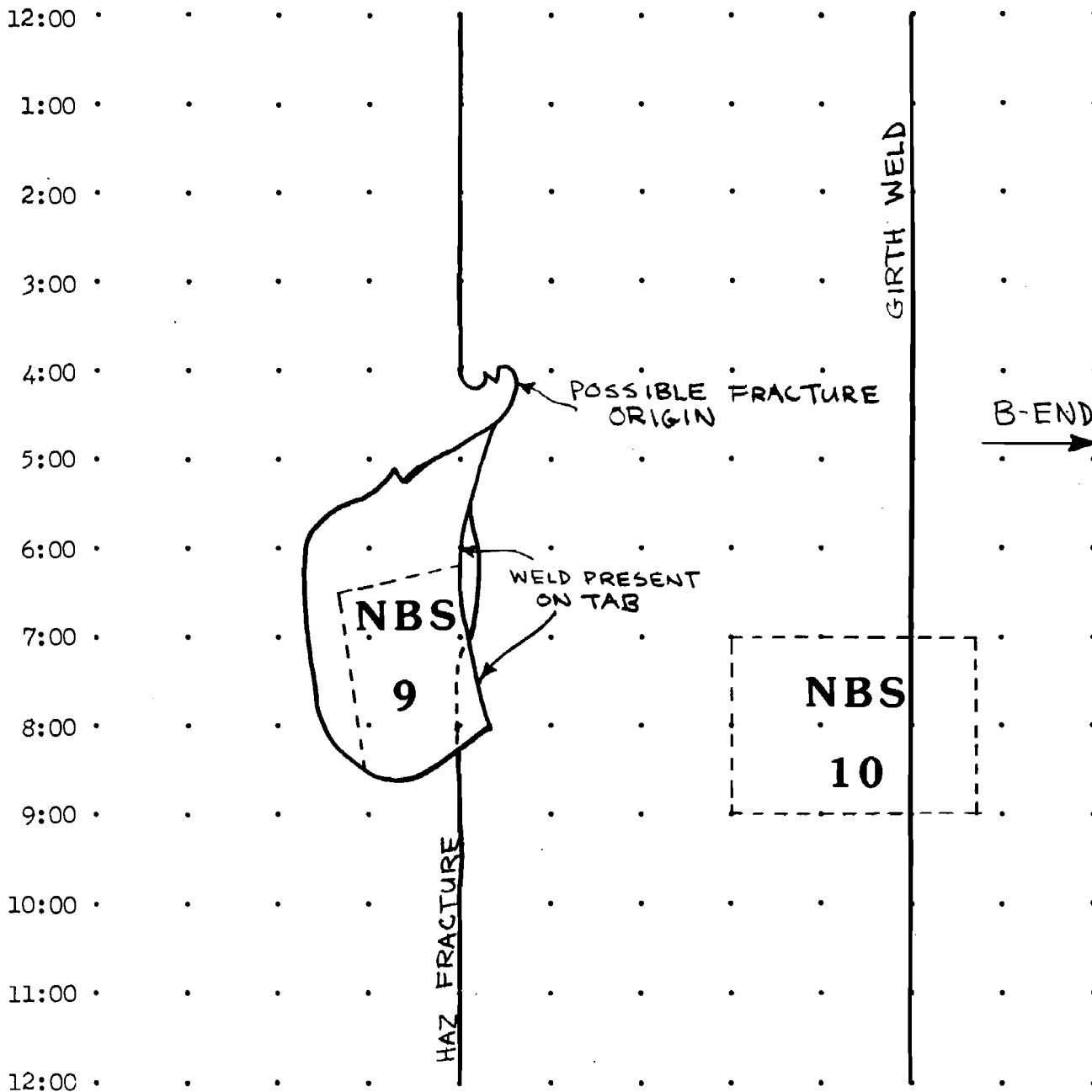



Photo C4-14: A-end tub of tank-car ACFX 89990 being carried in a gondola car.



Photo C4-15: A-end tub of tank-car ACFX 89990 being carried in a gondola car showing a large hole.



Photo C2-16: A-end tub of tank-car ACFX 89990 at the valve area.



Photo C2-15: A-end tub of tank-car ACFX 89990.



Photo C2-14: A-end tub of tank-car ACFX 89990.



Photo 2-9: B-end of tank-car ACFX 89990 showing samples NBS 9 and NBS 10.



Photo 2-10: B-end tub of tank-car ACFX 89990 showing samples NBS 9 and NBS 10.



Photo C2-17: B-end tub of tank-car ACFX 89990.



Photo C4-16: B-end tub of tank-car ACFX 89990 showing a large dent in the B head-plate.



Photo C2-20: Close-up of large dent in the B head-plate of tank-car ACFX 89990.



Photo C4-13: Circumferential fracture of the B-end tub of tank-car ACFX 89990.

Inspection Report of a Tank Car Involved in an Accident

Tank Car Number GATX 5013 and DOT Class 111A 100W
Identification of Samples Taken From This Car NBS 7
Inspection Date 4/19/79 and Location Milligan, Fla.
Accident Date 4/8/79 and Location Milligan, Fla.
Location in Train 59 Starting with Locomotive

Commodity Information: Loaded Empty _____
Commodity Methanol
Classification Flammable liquid

Mechanical Information: Continuous- _____ or Stub- _____ Sill
Type of Coupler F Type
Head Shield: Yes _____ No
Insulation: Yes _____ No

Identification of Photographs:

Black & White _____
Color C2-13, C3-5

Exposure to Fire: None _____ or Describe: Severe exposure to fire.

Observations:

Jacket: No Jacket or Describe: _____

Valves: _____

Shell and Head Plates: Badly damaged head plate that fractured (C3-5 photo) but did not run. Shell course (C2-13 photo) fractured but did not run. No significant damage observed on the (cont. on Attachment A)
Sill, Coupler, Wheel, other parts (in that order) _____

(cont. on Attachment _____)

A GATX 5013

B-head. The A-head contained numerous dents, one of which contained a short rupture.

Substantial deformation of the shell courses was observed with one fracture along a girth weld between two shell courses.

TANK-CAR ACCIDENT DOCUMENTATION
(DAMAGE AND SAMPLES)

Tank-Car Number GATX 5013
 Documented by S. Low / J. Early
 Date 5/8/79 and Location Railroad Siding, Pensacola Bay, Fla.

LOCATIONS OF SHELL COURSES, FRACTURES AND SAMPLES

(All views are from the outside of the tank car and fracture paths are indicated by dashed lines.)

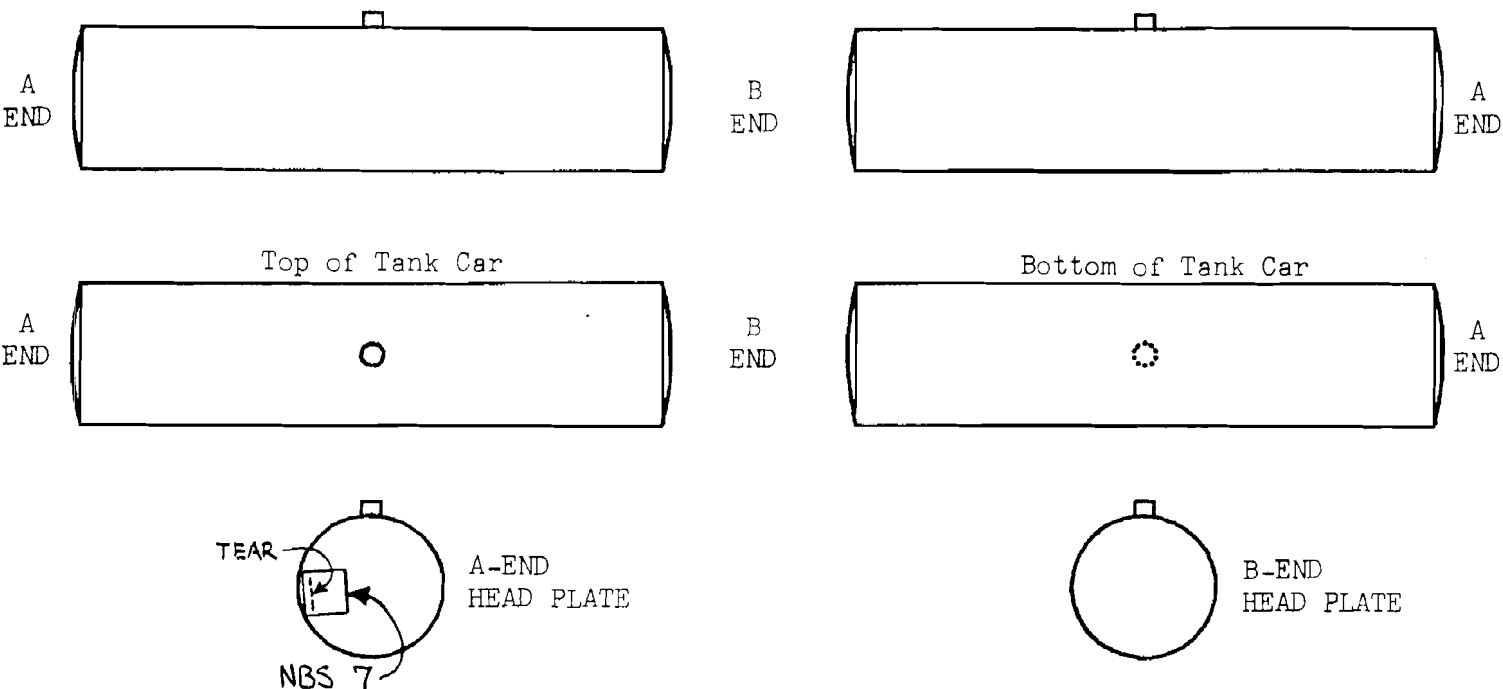

SAMPLE IDENTIFICATION NUMBER	OTHER SAMPLE IDENTIFICATION MARKINGS	LOCATION OF SAMPLE ON CAR
NBS 7		A-end Head Plate.



Photo C3-5: Tear in A-head of tank-car GATX 5013.



Photo C2-13: Close-up of tear at a shell seam in tank-car GATX 5013.

Inspection Report of a Tank Car Involved in an Accident

Tank Car Number UTLX 28727 and DOT Class 105A 300W
Identification of Samples Taken From This Car 20A and 20B
Inspection Date 4/19/79 and Location Milligan, Fla.
Accident Date 4/8/79 and Location Milligan, Fla.
Location in Train 60 Starting with Locomotive

Commodity Information: Loaded Empty _____
Commodity Chlorine
Classification Non-flammable liquid

Mechanical Information: Continuous- _____ or Stub- Sill
Type of Coupler F Type
Head Shield: Yes _____ No
Insulation: Yes No _____

Identification of Photographs:

Black & White _____
Color C1-15, C4-19, C4-20, C5-13

Exposure to Fire: None _____ or Describe: _____

Observations:

Jacket: No Jacket _____ or Describe: Shell jacket at valve dome was torn from car and wrapped around dome.

Valves: _____

Shell and Head Plates: The leaking shell course had a hole punched in it just below the middle of the shell course.

(cont. on Attachment _____)

Sill, Coupler, Wheel, other parts (in that order) _____

(cont. on Attachment _____)

TANK-CAR ACCIDENT DOCUMENTATION
(DAMAGE AND SAMPLES)

Tank-Car Number UTLX 28727
 Documented by S. Low / J. Early
 Date 5/8/79 and Location Railroad Siding, Pensacola Bay, Fla.

LOCATIONS OF SHELL COURSES, FRACTURES AND SAMPLES

(All views are from the outside of the tank car and fracture paths are indicated by dashed lines.)

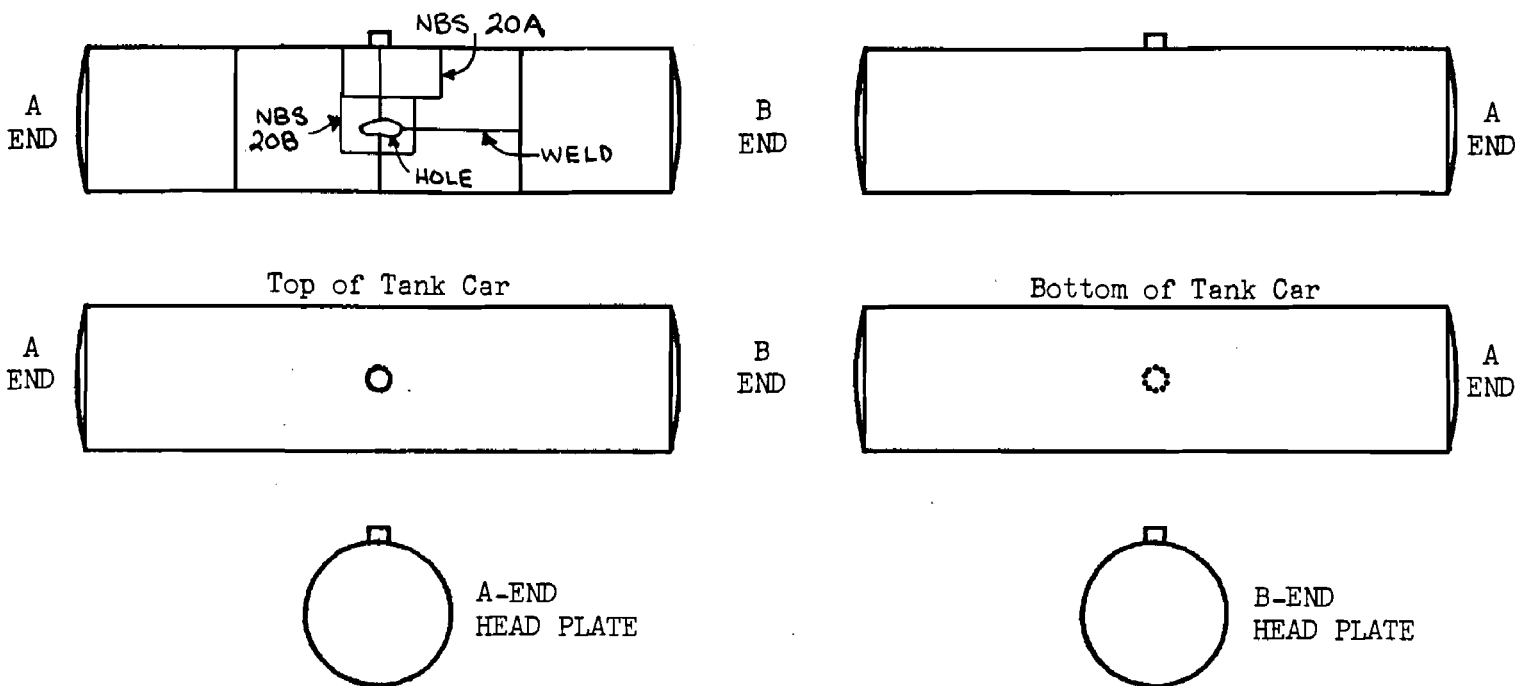

SAMPLE IDENTIFICATION NUMBER	OTHER SAMPLE IDENTIFICATION MARKINGS	LOCATION OF SAMPLE ON CAR
NBS 20A		Shell courses 2 & 3.
NBS 20B		Shell courses 2 & 3, containing hole.



Photo C1-15: Distant view of tank-car UILX 28727.



Photo C5-13: Tank-car UILX 28727 being carried on a flat car.



Photo C4-19: Tank-car UILX 28727 showing a hole in the center shell course.



Photo C4-20: Close-up of tank-car UILX 28727 showing a hole in the center shell course and samples NBS 20A and NBS 20B.

Inspection Report of a Tank Car Involved in an Accident

Tank Car Number IMCX 2513 and DOT Class 112S 400W
Identification of Samples Taken From This Car NBS 3 is shell of N. side tub
NBS 1, 2 on S. side & NBS 166
Inspection Date 4/19/79 and Location Milligan, Fla. 16A center piece.
Accident Date 4/8/79 and Location Milligan, Fla.
Location in Train 61 Starting with Locomotive

Commodity Information: Loaded Empty _____
Commodity Anhydrous NH₃
Classification Non-Flammable gas

Mechanical Information: Continuous- _____ or Stub- Sill _____
Type of Coupler Shelf F
Head Shield: Yes No _____
Insulation: Yes _____ No

Identification of Photographs: Tub on N. side of tracks-1-37, 1-33, 1-34;
Black & White S. side tub-1-12, 1-13, 1-14, 1-15, 2-13, 1-3.
Color N. side tub-C2-11, C2-12, C4-9, C4-10; S. side tub-C1-16, C1-19, C4-8;
S. side center piece-C3-9, C4-11, C4-12.

Exposure to Fire: None _____ or Describe: Totally removed most traces of paint
from South side tub. Tub found on North side of tracks was not in fire.

Observations:

Jacket: No Jacket or Describe: _____

Valves: _____

Shell and Head Plates: Rocketed (see descriptions attached).

(cont. on Attachment A)

Sill, Coupler, Wheel, other parts (in that order) _____

(cont. on Attachment _____)

A ICMX 2513

Rocketed tub, with 2-1/2 shell courses, was found on the South side of tracks. It had a badly dented head plate with no fractures. NBS 1 was taken on this head plate. The fracture line on this tub is contained in NBS 2.

North side tub, with 1-1/2 shell courses, is shown to be less affected by fire. See the photo 1-37 of this tub. The fracture face of this tub is shear everywhere except the part marked NBS 3.

The other 2⁺ courses were found on the south side of the tracks. The valve on it was marked NBS 16. See Notebook CGI Milligan, Fla., for a description of this piece of the car. Shear failure was observed almost everywhere along the failed edges of the plates. One location showed considerable plate thinning. In several locations, the shear fracture appearance indicated that plate centerline inclusion content is probably high.

TANK-CAR ACCIDENT DOCUMENTATION
(DAMAGE AND SAMPLES)

Tank-Car Number IMCX 2513
 Documented by S. Low / J. Early
 Date 5/8/79 and Location Railroad Siding, Pensacola Bay, Fla.

LOCATIONS OF SHELL COURSES, FRACTURES AND SAMPLES

(All views are from the outside of the tank car and fracture paths are indicated by dashed lines.)

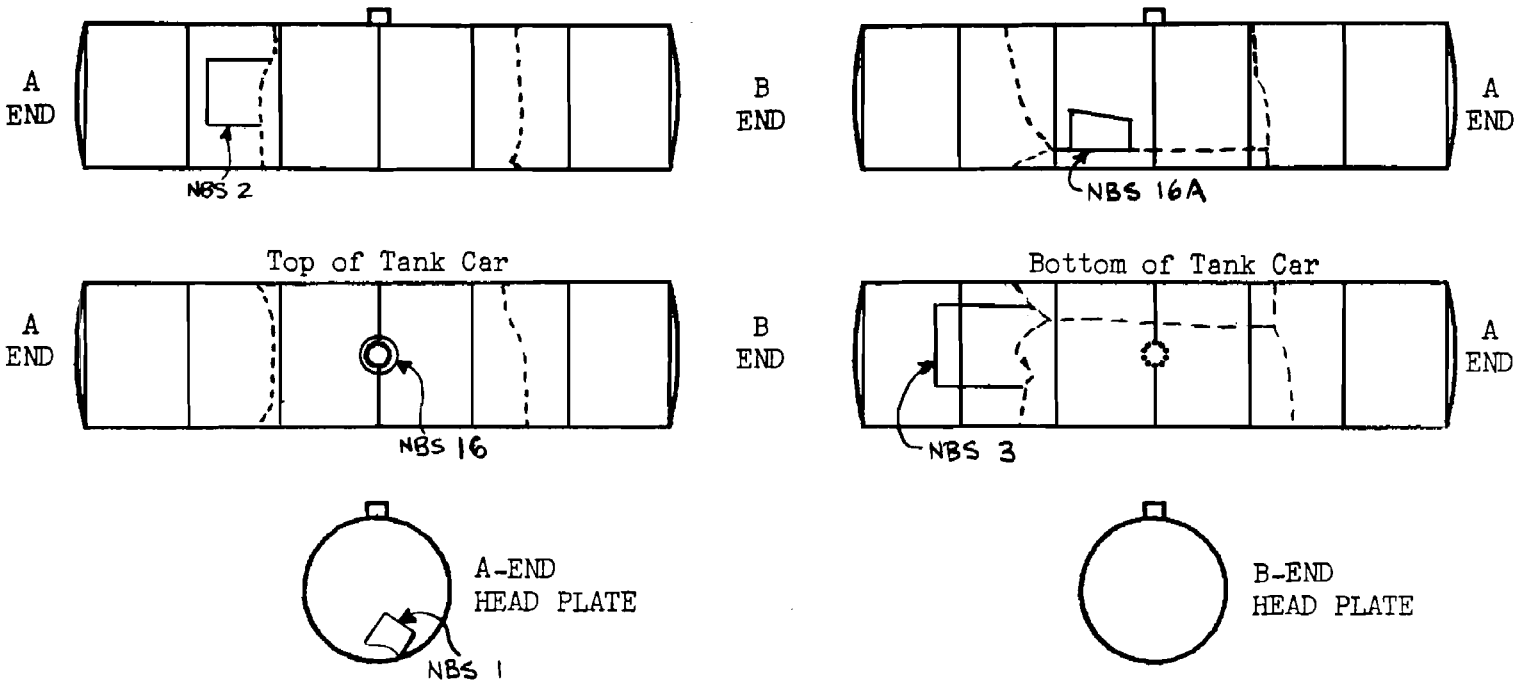

SAMPLE IDENTIFICATION NUMBER	OTHER SAMPLE IDENTIFICATION MARKINGS	LOCATION OF SAMPLE ON CAR
NBS 1		A-end Head Plate.
NBS 2		Shell course 2, along A-end fracture.
NBS 3		Shell courses 5 & 6 along B-end fracture
NBS 16		Valve.
NBS 16A		Shell course 4, along long. fracture.

TANK-CAR ACCIDENT DOCUMENTATION
(FRACTURE PATH)

Tank-Car Number IMCX 2513
 Documented by S. Low
 Date 5/8/79 and Location Railroad Siding, Pensacola Bay, Fla.

SHELL COURSES AND THIS FRACTURE LOCATION

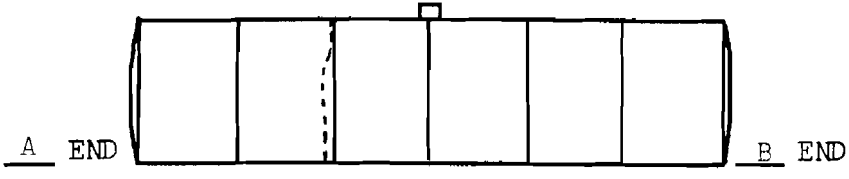

All time references are made for viewing from the A-End to the B-End of the tank car.

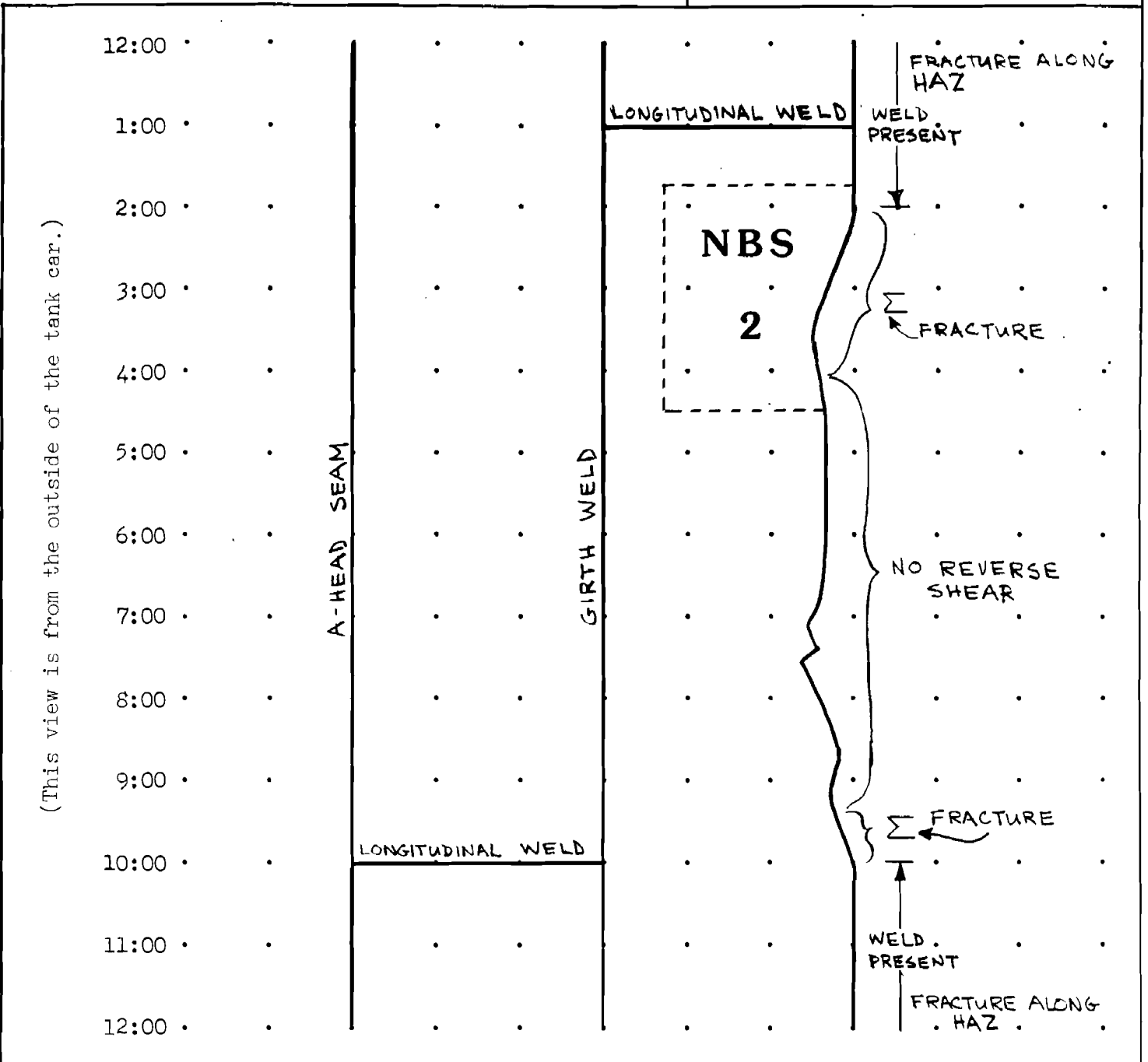
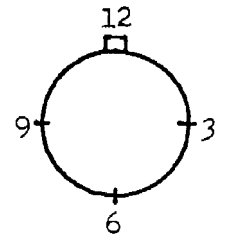

TANK-CAR ACCIDENT DOCUMENTATION
(FRACTURE PATH)

Tank-Car Number IMCX 2513
 Documented by S. Low
 Date 5/8/79 and Location Railroad siding, Pensacola Bay, Fla.

SHELL COURSES AND THIS FRACTURE LOCATION

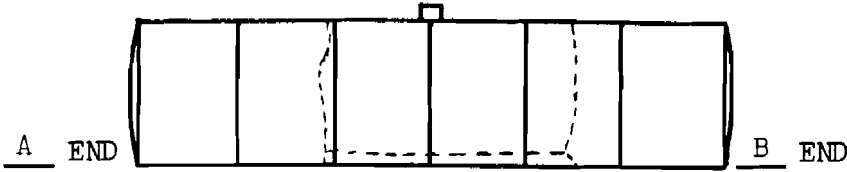

All time references are made for viewing from the A-End to the B-End of the tank car.

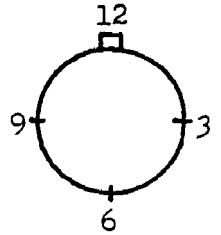



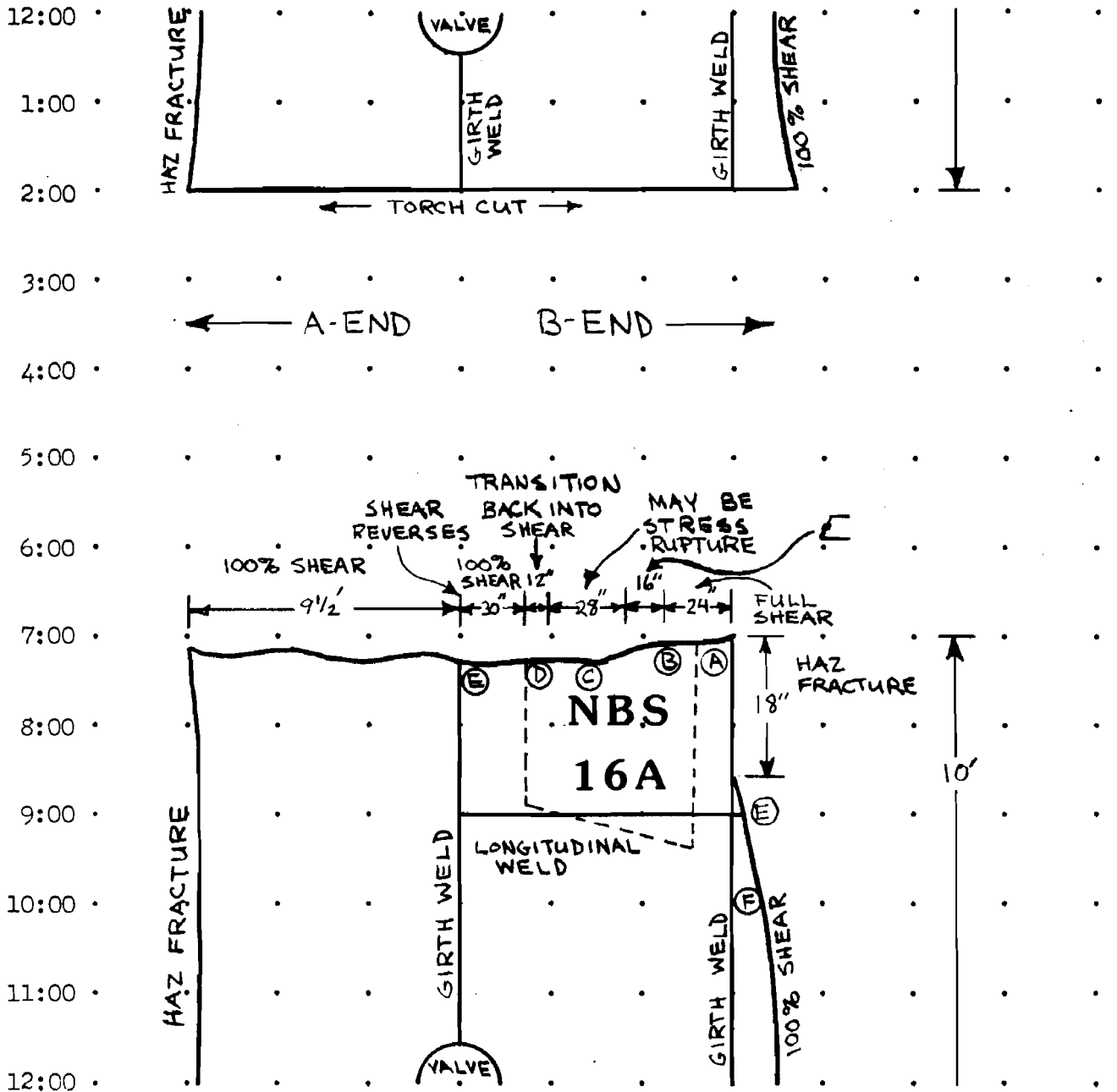

This view is from the outside of the tank car.)



TANK-CAR ACCIDENT DOCUMENTATION
(FRACTURE MODE)

Tank-Car Number IMCX 2513
 Documented by S. Low / J. Early
 Date 5/8/79 and Location Railroad Siding, Pensacola Bay, Fla.

FRACTURE LOCATION (All time references are made for viewing from the A-End to the B-End of tank car.)	CROSS-SECTIONAL VIEW OF THE FRACTURE
A-end fracture 2:30 - 4:00 9:30 - 10:00	
A-end fracture 4:00 - 9:30 B-end fracture 12:00 - 3:00 & 6:00 - 7:00	 DUCTILE
B-end fracture 7:00 - 10:30 3:00 - 5:00	 lamellae
B-end fracture near 6:00	
B-end fracture 5:00 - 6:00	 lamellae

CIRCUMFERENTIAL FRACTURE DIRECTION

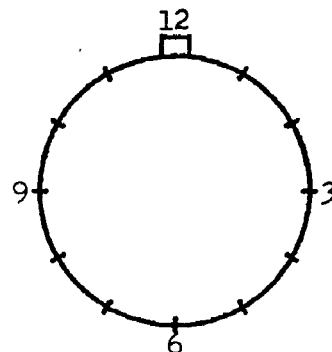

Location _____

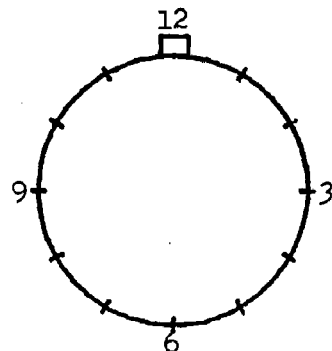

Location _____

LONGITUDINAL FRACTURE DIRECTION

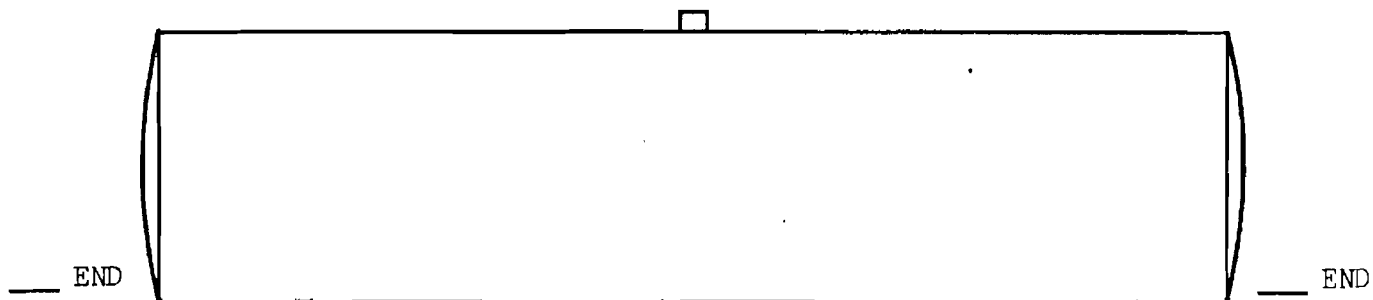

TANK-CAR ACCIDENT DOCUMENTATION

(PLATE THINNING)

Tank-Car Number IMCX 2513

Documented by S. Low / J. Early

Date 5/8/79 and Location Railroad Siding, Pensacola Bay, Fla.

FRACTURE LOCATION (All time references are made for viewing from the A-End to the B-End of the tank car.)				PLATE THICKNESS At This Distance From the Fracture		
	6 mm	114 mm		6 mm	114 mm	
Location A at B-edge, center section.	18.2 mm	18.6 mm				
Location B at 30" from B-edge, center section.	15.3 mm	17.8 mm				
Location C at 62" from B-edge, center section.	13.4 mm	18.0 mm				
Location D at 78" from B-edge, center section.	15.2 mm	17.8 mm				
Location E at center girth weld, center section.	17.7 mm	18.5 mm				
Location F at 18" below long. weld, center section.	19.8 mm	19.4 mm				
Location at 3:15 of A-end fracture, A section.	18.0 mm	19.2 mm				
Location at 4:15 of A-end fracture, A section.	18.2 mm	19.2 mm				
Location at 9:00 of A-end fracture, A section.	18.2 mm	19.2 mm				
Location at 2:00 of B-end fracture, B section.	18.8 mm	19.4 mm				
Location at 4:00 of B-end fracture, B section.	19.2 mm	19.6 mm				
Location at 10:00 of B-end fracture, B section.	18.9 mm	19.8 mm				



Photo 1-37: North side tub (B-end) of tank-car
IMCX 2513.



Photo C4-9: North side tub (B-end) of tank-car
IMCX 2513 being carried in a gondola
car.

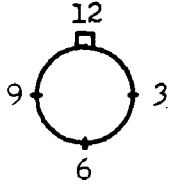

Photo C4-10: North side tub (B-end) of tank-car IMCX 2513 being carried with other debris in a gondola car.



Photo C2-12: Dent in head plate of the north side tub (B-end) of tank-car IMCX 2513.



Photo C2-11: Dent in head plate of the north side tub (B-end) of tank-car IMCX 2513.



Photo 2-13: Distant view of the south side tub (A-end) of tank-car IMCX 2513.



Photo 1-12: South side tub (A-end) of tank car
IMCX 2513.



Photo 1-15: South side tub (A-end) of tank-car
IMCX 2513.



Photo C4-8: South side tub (A-end) of tank-car
IMCX 2513 showing sample NBS 2.



Photo C1-16: South side tub (A-end) of tank-car
IMCX 2513.



Photo 1-14: Head plate of the south side tub (A-end) of tank-car IMCX 2513 showing sample NBS 1.



Photo 1-13: Close-up of the head plate of the south side tub (A-end) of tank-car IMCX 2513.



Photo C1-19: Close-up of a dent in the head plate of the south side tub (A-end) of tank-car IMCX 2513.



Photo C3-9: Center section of tank-car IMCX 2513 on the south side of the tracks.



Photo C4-11: Center section of tank-car IMCX 2513 showing sample NBS 16A.

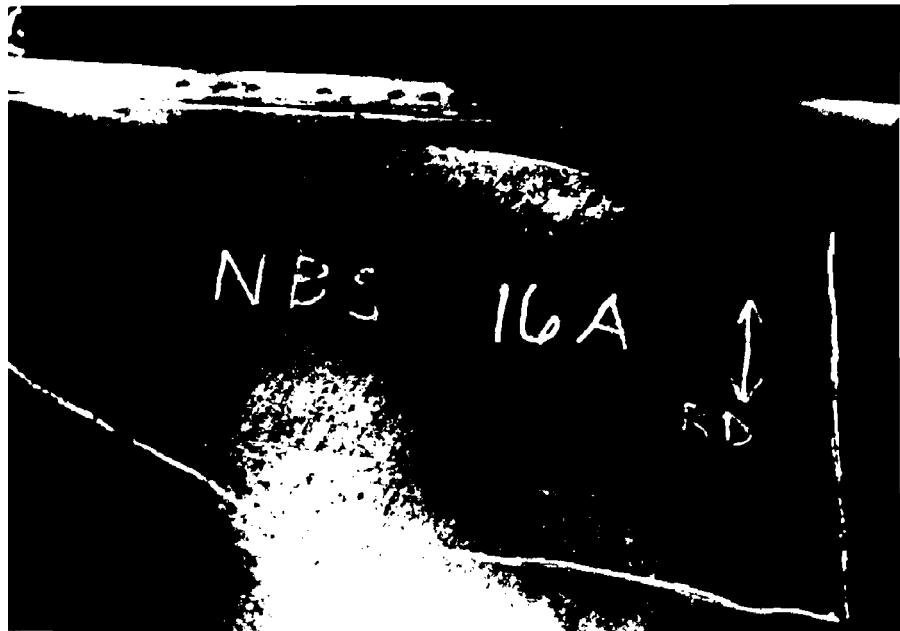

Photo C4-12: Close-up of sample NBS 16A marked on the center section of tank-car IMCX 2513.

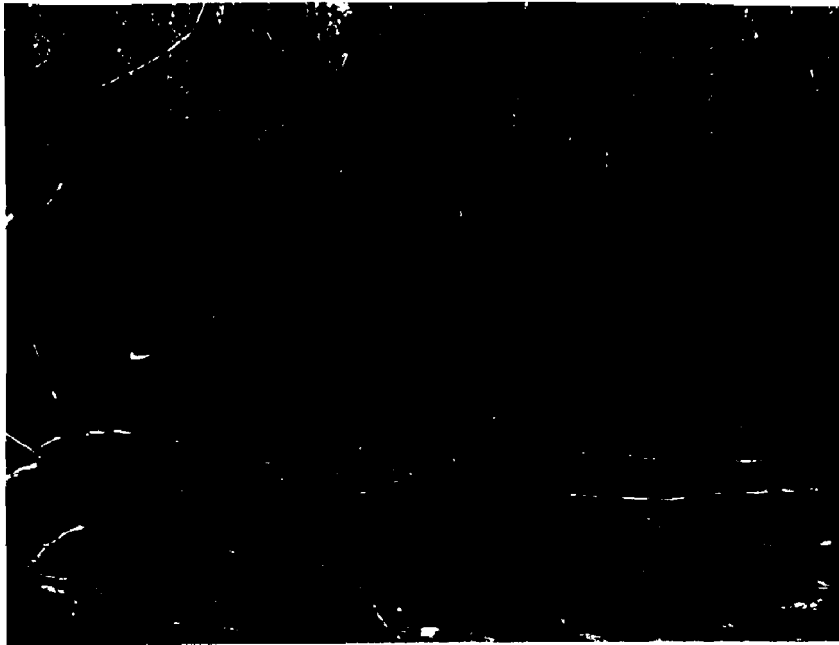

Photo 1-33: Burned out section of woods on the North side of tracks and beyond the North side tube of ICMX 2513.



Photo 1-34: Same as 1-33 But in a section of woods a bit closer to the track and West of photo 1-33.



Photo 1-3: Photo taken looking West along track.
South side cars are on the left.

Inspection Report of a Tank Car Involved in an Accident

Tank Car Number IMCX 2923 and DOT Class 105A 300W
Identification of Samples Taken From This Car _____
Inspection Date 4/19/79 and Location Milligan, Fla.
Accident Date 4/8/79 and Location Milligan, Fla.
Location in Train 62 Starting with Locomotive

Commodity Information: Loaded Empty _____
Commodity Anhydrous NH₃
Classification Flammable gas

Mechanical Information: Continuous- _____ or Stub- _____ Sill
Type of Coupler F Type
Head Shield: Yes _____ No
Insulation: Yes No _____

Identification of Photographs:

Black & White 2-12, 2-14
Color C3-10

Exposure to Fire: None _____ or Describe: Yes (see photo), it appears to have been engulfed.

Observations:

Jacket: No Jacket _____ or Describe: One or two small fractures and some wrinkles in the jacket (see photos).

Valves: _____

Shell and Head Plates: _____

(cont. on Attachment _____)

Sill, Coupler, Wheel, other parts (in that order) _____

(cont. on Attachment _____)



Photo C3-10: Tank-car IMCX 2923.



Photo 2-12: Tank-car IMCX 2923.



Photo 2-14: Close-up of tank-car IMCX 2923.

Inspection Report of a Tank Car Involved in an Accident

Tank Car Number IMCX 2917 and DOT Class 105A 300W

Identification of Samples Taken From This Car _____

Inspection Date 4/19/79 and Location Milligan, Fla.

Accident Date 4/8/79 and Location Milligan, Fla.

Location in Train 63 Starting with Locomotive

Commodity Information: Loaded Empty _____

Commodity Anhydrous NH₃

Classification Non-Flammable gas

Mechanical Information: Continuous- _____ or Stub- Sill

Type of Coupler F Type

Head Shield: Yes _____ No

Insulation: Yes No _____

Identification of Photographs:

Black & White 2-34, 2-33

Color _____

Exposure to Fire: None _____ or Describe: _____

Observations:

Jacket: No Jacket _____ or Describe: _____

Valves: _____

Shell and Head Plates: _____

(cont. on Attachment _____)

Sill, Coupler, Wheel, other parts (in that order) This car was rolled over to empty it of the remaining anhydrous ammonia. Photo 2-33 shows underside and 2-34 shows top side of car.

(cont. on Attachment _____)



Photo 2-33: Tank-car IMCX 2917 showing the bottom area of the car.



Photo 2-34: Tank-car IMCX 2917 showing the top area of the car.

Inspection Report of a Tank Car Involved in an Accident

Tank Car Number IMCX 2827 and DOT Class 105A 300W
Identification of Samples Taken From This Car 11, 12, 17 (valve)
Inspection Date 4/19/79 and Location Milligan, Fla.
Accident Date 4/8/79 and Location Milligan, Fla.
Location in Train 64 Starting with Locomotive

Commodity Information: Loaded Empty _____
Commodity Anhydrous NH₃
Classification Non-Flammable gas

Mechanical Information: Continuous- _____ or Stub- Sill
Type of Coupler F Type
Head Shield: Yes _____ No
Insulation: Yes No _____

Identification of Photographs:

Black & White 2-7, 2-8 (North side); and 2-23, 2-24, 2-25 (South side tub)
Color N. side - C2-18, C4-1 to C4-5, S. Side - C3-12, C4-6, C4-7

Exposure to Fire: None _____ or Describe: Some visual evidence that middle of car was heated where rupture occurred. Jacket away from this region appears to have seen very little fire exposure.

Observations:

Jacket: No Jacket _____ or Describe: Jacket intact except over shell courses containing fracture.

Valves: 225 lb. safety release setting; valve is NBS 11.

Shell and Head Plates: Rocketed and landed >1000 ft. south of tracks. NBS 12 is sample on north side tube (see photo 2-8) A portion of the shell course (1-2 ft.) at the fracture is missing. (cont. on Attachment A)

Sill, Coupler, Wheel, other parts (in that order) _____

(cont. on Attachment _____)

A ICMX 2827

and was not found during clean-up of accident site. Chevron marks were recorded on this, a largely brittle, fracture. See photo 2-8. Sample NBS 12 does not contain this characteristic fracture, except on NBS 12 extended.

NBS 17 is taken from the South side tub in the course containing the fracture, but the sample contains none of the fracture. This course is one shell removed from the head.

Photo 2-24 shows the fracture as it appears on the south side tub. NBS 12 extended cannot be removed as it has been used to lash this tub to a flat car for removal from the accident site.

TANK-CAR ACCIDENT DOCUMENTATION
(DAMAGE AND SAMPLES)

Tank-Car Number IMCX 2827
 Documented by S. Low / J. Early
 Date 5/8/79 and Location Railroad Siding, Pensacola Bay, Fla.

LOCATIONS OF SHELL COURSES, FRACTURES AND SAMPLES

(All views are from the outside of the tank car and fracture paths are indicated by dashed lines.)

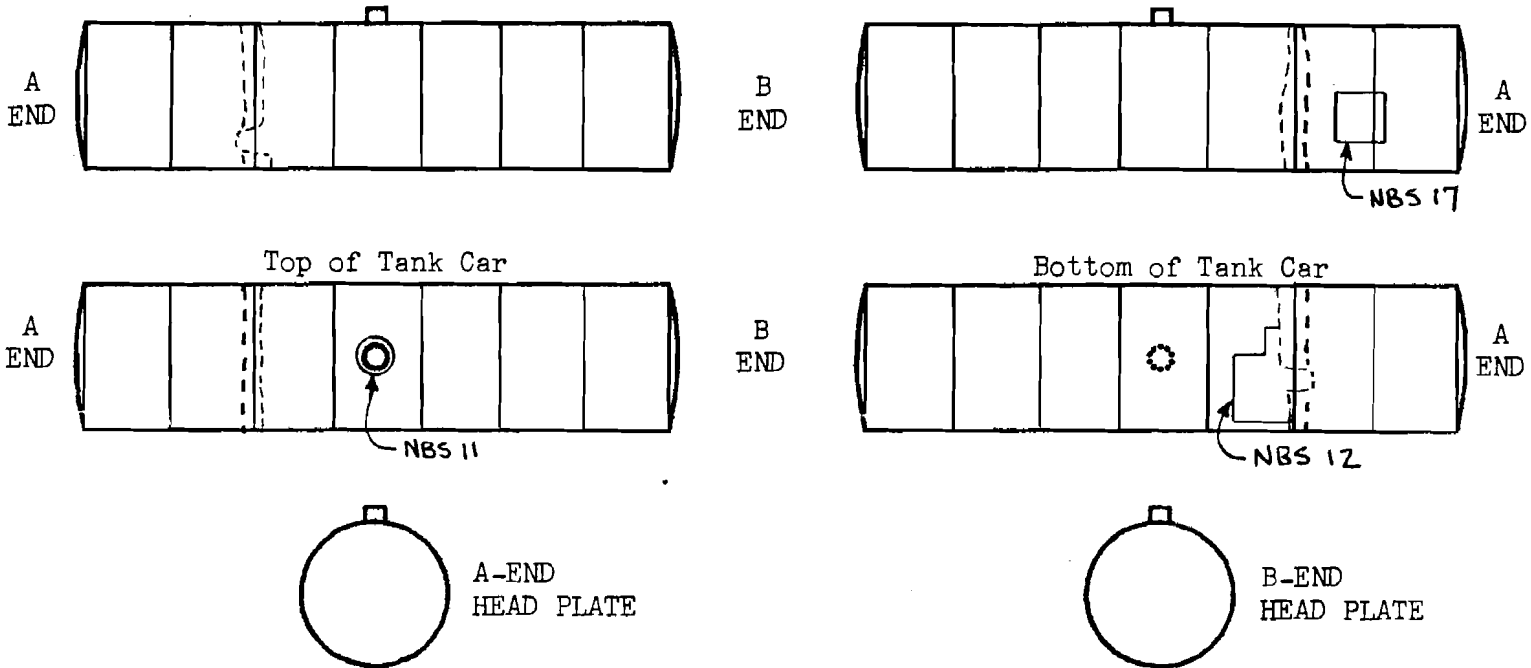

SAMPLE IDENTIFICATION NUMBER	OTHER SAMPLE IDENTIFICATION MARKINGS	LOCATION OF SAMPLE ON CAR
NBS 11		Valve.
NBS 12		Shell courses 2 & 3, along fracture.
NBS 17		Shell courses 1 & 2.

TANK-CAR ACCIDENT DOCUMENTATION

(FRACTURE PATH)

Tank-Car Number IMCX 2827

Documented by S. Low / J. Early

Date 5/8/79 and Location Railroad Siding, Pensacola Bay, Fla.

SHELL COURSES AND THIS FRACTURE LOCATION

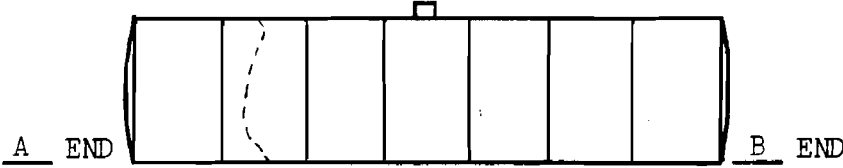



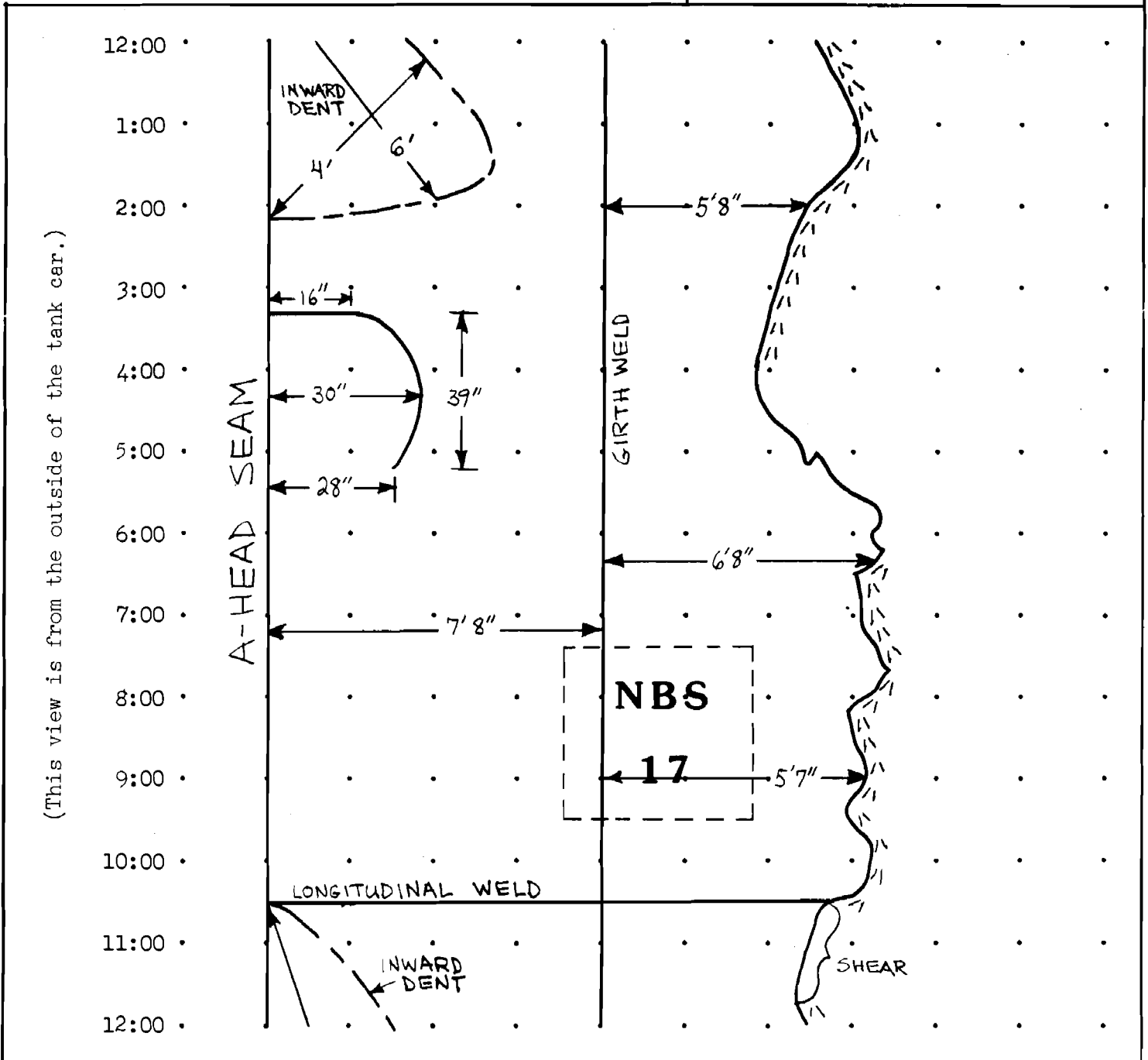
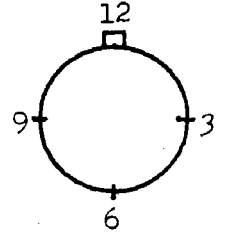

All time references are made for viewing from the A-End to the B-End of the tank car.



(This view is from the outside of the tank car.)

TANK-CAR ACCIDENT DOCUMENTATION
(FRACTURE MODE)

Tank-Car Number IMCX 2827
 Documented by S. Low / J. Early
 Date 5/8/79 and Location Railroad Siding, Pensacola Bay, Fla.

FRACTURE LOCATION (All time references are made for viewing from the A-End to the B-End of tank car.)	CROSS-SECTIONIAL VIEW OF THE FRACTURE
Fracture on B-end 7:00 - 9:30	 Brittle
Fracture on B-end 9:30 - 4:00	 Brittle
Fracture on A-end 12:30 - 1:30	 Ductile
Fracture on A-end 8:00 - 12:30 1:30 - 5:30	 Brittle

CIRCUMFERENTIAL FRACTURE DIRECTION

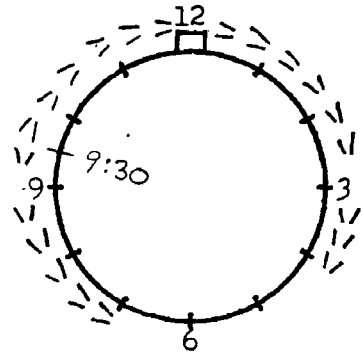

Location Fracture on B-end.
Shell course 2.

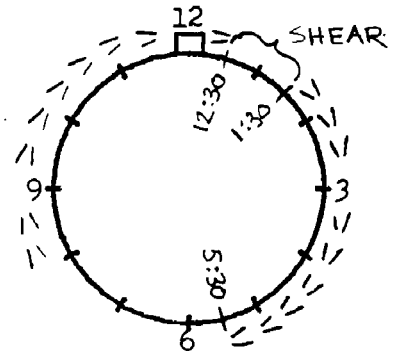

Location Fracture on A-end.
Shell course 2.

LONGITUDINAL FRACTURE DIRECTION

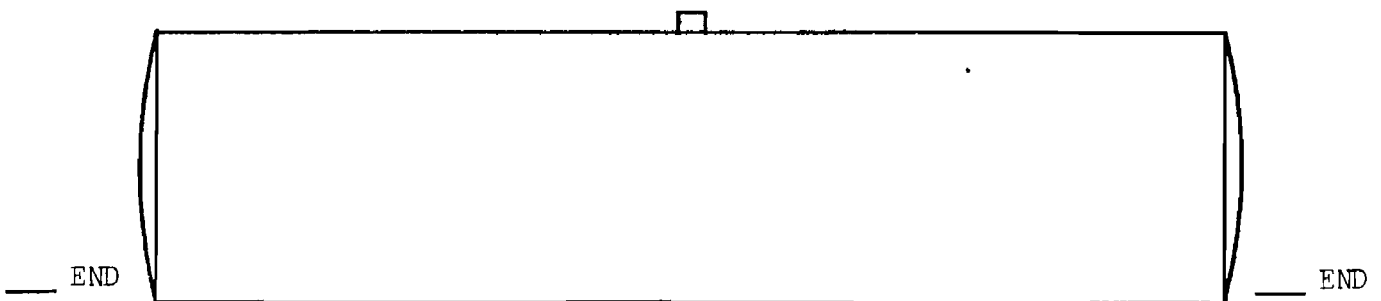



Photo 2-7: North side tub (B-end) of tank-car
IMCX 2827 showing sample NBS 11 (valve).



Photo C2-18: North side tub (B-end) of tank-car
IMCX 2827.



Photo C4-5: B head of the north side tub of tank-car
IMCX 2827.



Photo C4-1: North side tub (B-end) of tank-car
IMCX 2827 being carried on a flat car.



Photo C4-2: North side tub (B-end) of tank-car
IMCX 2827.



Photo 2-8: North side tub (B-end) of tank-car
IMCX 2827 showing sample NBS 12.

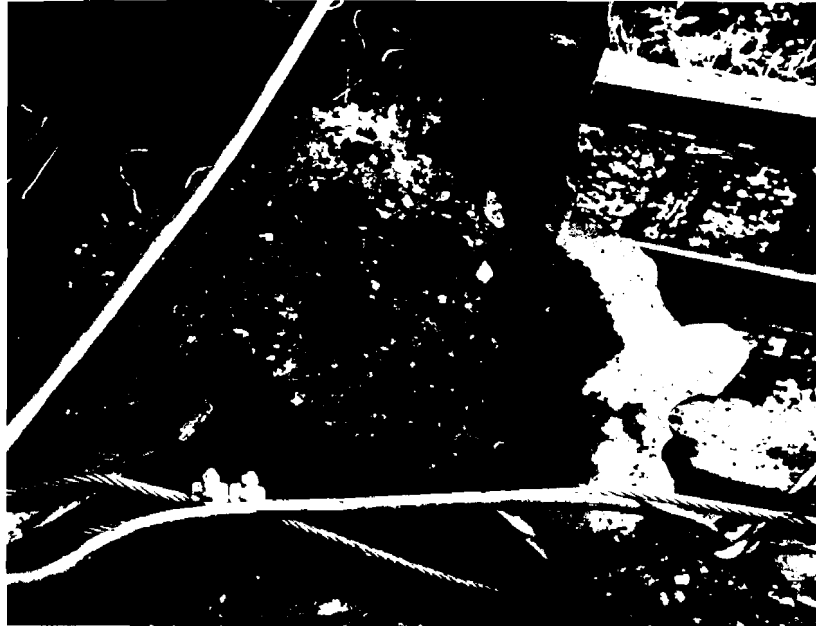

Photo C4-4: North side tub (B-end) of tank-car
IMCX 2827 showing the area of sample
NBS 12, the probable fracture origin.

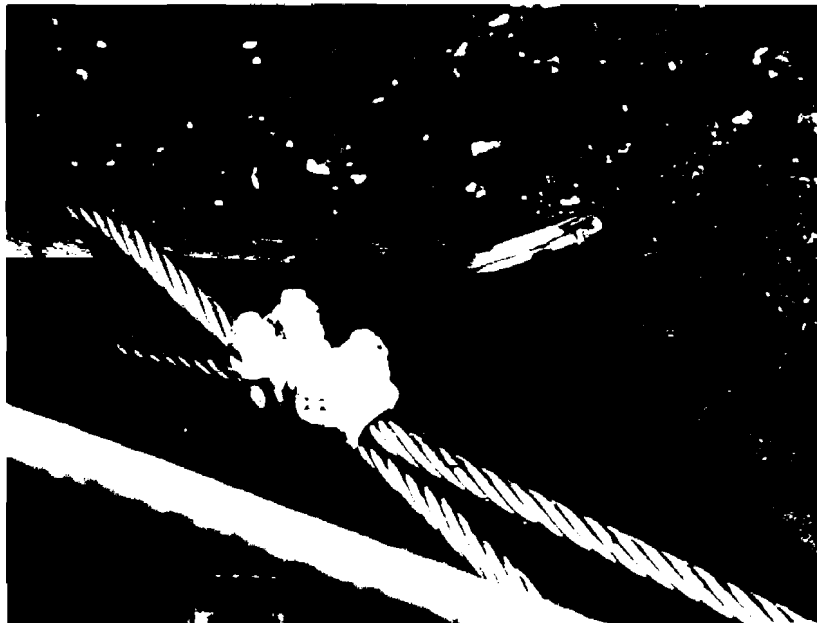

Photo C4-3: Close-up of the probable fracture origin
of the north side tub (8-end) of tank-
car ICX 2827.



Photo C3-12: South side tub (A-end) of tank-car IMCX 2827 (right) and tank car ACFX 82959 (left).



Photo C4-6: South side tub (A-end) of tank-car IMCX 2827 being carried in a gondola car.



Photo C4-7: South side tub (A-end) of tank-car IMCX 2827 being carried in a gondola car showing sample NBS 17.



Photo 2-23: South side tub (A-end) of tank-car IMCX 2827.



Photo 2-25: South side tub (A-end) of tank-car IMCX 2827 showing sample NBS 17.



Photo 2-24: Fracture face on the south side tub (A-end) of tank-car IMCX 2827.

Inspection Report of a Tank Car Involved in an Accident

Tank Car Number ICMX 2586 and DOT Class 112S 400W
Identification of Samples Taken From This Car _____
Inspection Date 4/19/79 and Location Milligan, Fla.
Accident Date 4/8/79 and Location Milligan, Fla.
Location in Train 65 Starting with Locomotive

Commodity Information: Loaded X Empty _____
Commodity Anhydrous NH₃
Classification Non-Flammable gas

Mechanical Information: Continuous- _____ or Stub- _____ Sill _____
Type of Coupler Shelf F Type
Head Shield: Yes X No _____
Insulation: Yes _____ No X

Identification of Photographs:
Black & White 2-11
Color C3-8

Exposure to Fire: None _____ or Describe: _____

Observations:

Jacket: No Jacket _____ or Describe: _____

Valves: _____

Shell and Head Plates: Not badly damaged. See photo.

(cont. on Attachment _____)

Sill, Coupler, Wheel, other parts (in that order) This car apparently had head shields that were ripped off in the accident, possibly pulled away from the car. Each head plate had a small dent at the 5 o'clock position. The B head was found and it looked (cont. on Attachment A)

A ICMX 2586

relatively unchanged from its original shape, but it was partly buried and could not be properly examined.

The A-head shield was partially ripped off the head. Some gouging observed on head plate. The 5 o'clock dent in the head was located behind where the head shield should have been located. This strongly suggests that the dent in the A-head occurred after the head shield had been displaced by the accident. The head shield on the B-head was completely missing from the tank car.



Photo 2-11: A-end of tank-car IMCX 2586.



Photo C3-8: Close-up of the A-head and head shield of tank-car IMCX 2586.

Inspection Report of a Tank Car Involved in an Accident

Tank Car Number ACFX 18636 and DOT Class 112A 340W
Identification of Samples Taken From This Car NBS 5 deleted for safety.
Inspection Date 4/19/79 and Location Milligan, Fla.
Accident Date 4/8/79 and Location Milligan, Fla.
Location in Train 66 Starting with Locomotive

Commodity Information: Loaded Empty _____
Commodity Anhydrous NH₃
Classification Non-Flammable gas

Mechanical Information: Continuous- _____ or Stub- _____ Sill _____
Type of Coupler Shelf E Type
Head Shield: Yes _____ No
Insulation: Yes _____ No

Identification of Photographs:
Black & White _____
Color C3-2

Exposure to Fire: None or Describe: _____

Observations:
Jacket: No Jacket or Describe: _____

Valves: _____

Shell and Head Plates: Head plate (unshielded) was badly scraped and had large dent. NBS 5 is sample of this. No significant damage observed on B-head. The A-head contained a large dent near the sill. (cont. on Attachment _____)

Sill, Coupler, Wheel, other parts (in that order) _____

(cont. on Attachment _____)

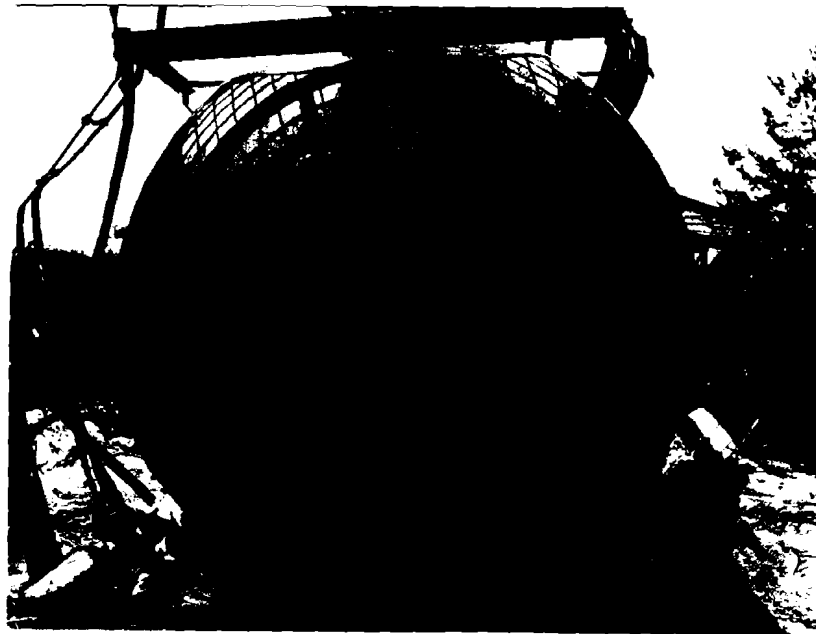

Photo C3-2: A-head of tank-car ACFX 18636 showing a large dent near the sill.

Inspection Report of a Tank Car Involved in an Accident

Tank Car Number UTLX 77528 and DOT Class 111A 100W

Identification of Samples Taken From This Car _____

Inspection Date 4/19/79 and Location Milligan, Fla.

Accident Date 4/8/79 and Location Milligan, Fla.

Location in Train 67 Starting with Locomotive

Commodity Information: Loaded Empty _____

Commodity Carbolic Acid

Classification Poison B

Mechanical Information: Continuous- _____ or Stub- _____ Sill

Type of Coupler _____

Head Shield: Yes _____ No

Insulation: Yes _____ No _____

Identification of Photographs:

Black & White _____

Color _____

Exposure to Fire: None _____ or Describe: _____

Observations:

Jacket: No Jacket _____ or Describe: _____

Valves: _____

Shell and Head Plates: _____

(cont. on Attachment _____)

Sill, Coupler, Wheel, other parts (in that order) _____

(cont. on Attachment _____)

Inspection Report of a Tank Car Involved in an Accident

Tank Car Number UTLX 40907 and DOT Class 111A 100W1

Identification of Samples Taken From This Car _____

Inspection Date 4/19/79 and Location Milligan, Fla.

Accident Date 4/8/79 and Location Milligan, Fla.

Location in Train 68 Starting with Locomotive _____

Commodity Information: Loaded Empty _____

Commodity Methanol

Classification Flammable liquid

Mechanical Information: Continuous- _____ or Stub- _____ Sill _____

Type of Coupler F Type

Head Shield: Yes _____ No

Insulation: Yes _____ No _____

Identification of Photographs:

Black & White _____

Color _____

Exposure to Fire: None _____ or Describe: _____

Observations:

Jacket: No Jacket _____ or Describe: _____

Valves: _____

Shell and Head Plates: _____

(cont. on Attachment _____)

Sill, Coupler, Wheel, other parts (in that order) _____

(cont. on Attachment _____)

Inspection Report of a Tank Car Involved in an Accident

Tank Car Number ACFX 89345 and DOT Class 111A 100W1

Identification of Samples Taken From This Car _____

Inspection Date 4/19/79 and Location Milligan, Fla.

Accident Date 4/8/79 and Location Milligan, Fla.

Location in Train 69 Starting with Locomotive

Commodity Information: Loaded Empty _____

Commodity Methanol

Classification Flammable liquid

Mechanical Information: Continuous- _____ or Stub- _____ Sill

Type of Coupler BE 60 BHT

Head Shield: Yes _____ No

Insulation: Yes _____ No _____

Identification of Photographs:

Black & White _____

Color _____

Exposure to Fire: None _____ or Describe: _____

Observations:

Jacket: No Jacket _____ or Describe: _____

Valves: _____

Shell and Head Plates: _____

(cont. on Attachment _____)

Sill, Coupler, Wheel, other parts (in that order) _____

(cont. on Attachment _____)

APPENDIX

TANK-CAR ACCIDENT DOCUMENTATION FORMS

Damage and Samples

Fracture Path

Fracture Mode

Plate Thinning

U.S. DEPT. OF COMM. BIBLIOGRAPHIC DATA SHEET <i>(See instructions)</i>	1. PUBLICATION OR REPORT NO.	2. Performing Organ. Report No.	3. Publication Date
4. TITLE AND SUBTITLE Observations of the April 8, 1979 Railroad Accident at Crestview, Florida			
5. AUTHOR(S) Dr. Charles G. Interrante, Mr. Samuel R. Low, Dr. James G. Early and Mr. David Dancer			
6. PERFORMING ORGANIZATION <i>(If joint or other than NBS, see instructions)</i> NATIONAL BUREAU OF STANDARDS DEPARTMENT OF COMMERCE WASHINGTON, D.C. 20234			7. Contract/Grant No. 8. Type of Report & Period Covered Final Report
9. SPONSORING ORGANIZATION NAME AND COMPLETE ADDRESS <i>(Street, City, State, ZIP)</i> Office of Rail Safety Research Federal Railroad Administration Washington, D.C.			
10. SUPPLEMENTARY NOTES <input type="checkbox"/> Document describes a computer program; SF-185, FIPS Software Summary, is attached.			
11. ABSTRACT <i>(A 200-word or less factual summary of most significant information. If document includes a significant bibliography or literature survey, mention it here)</i> This report contains the results of field investigation of the behavior and response of 28 tank cars which derailed on April 8, 1979 near Crestview, Florida. The pictorial representation of the damage to the cars as well as the field measurements and other data necessary for any subsequent metallurgical evaluation of the materials of construction are reported on a series of prepared forms developed for field accident investigation.			
12. KEY WORDS <i>(Six to twelve entries; alphabetical order; capitalize only proper names; and separate key words by semicolons)</i> accident investigation; accident investigation forms; Crestview, Florida railroad accident; failure analysis; impact failure; pressure vessel; railroad accident; tank car accident			
13. AVAILABILITY <input type="checkbox"/> Unlimited <input checked="" type="checkbox"/> For Official Distribution. Do Not Release to NTIS <input type="checkbox"/> Order From Superintendent of Documents, U.S. Government Printing Office, Washington, D.C. 20402. <input type="checkbox"/> Order From National Technical Information Service (NTIS), Springfield, VA. 22161			14. NO. OF PRINTED PAGES 15. Price