

# PHASE I

02-Track-Train Dynamics

2-180



An International Government-Industry Research Program on Track-Train Dynamics

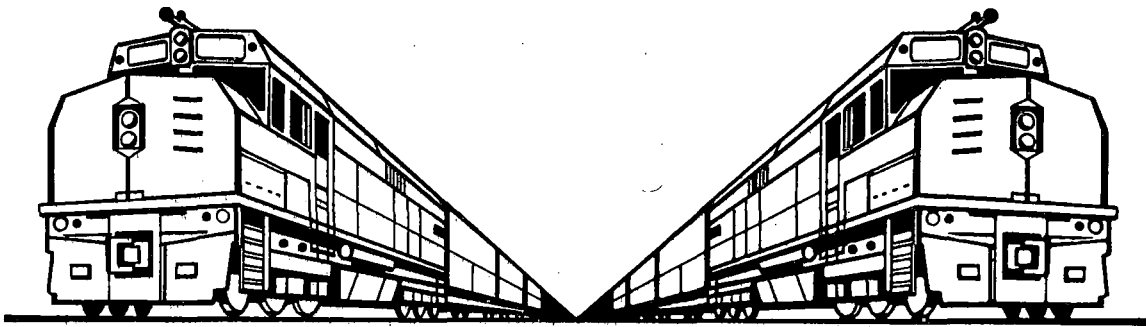

# TRACK TRAIN DYNAMICS

Copyright © 1975  
Association of American Railroads

## ACKNOWLEDGEMENTS

More than 15000 man days of effort have gone into the completion of the Phase I activities. It would be a monumental task to acknowledge in detail the contributions of all who were involved. Many of the documents that have been published, or will be published in the near future, contain a section which credits the principal contributors of that particular effort.

I feel however, that special credit should be given to those principals and organizations who played key roles in the Phase I effort.

One of the prime visionaries of the coordinated government-industry-AAR 10-year research concept was Dr. W. J. Harris, Jr. His background of research in the private and federal sector, his recognition of the large effort necessary, his articulate presentations of essential facts to those who later became important elements of the coordinated effort, and expert guidance throughout the tenure of Phase I, led to a successful effort.

It was mainly through Dr. Harris and the Association of American Railroads that the 10-year Program was conceived as a result of a contract with the Southern Pacific Transportation Company back in the early 1970's. The conceptual plan presented by the Southern Pacific has thus far proven to be a sound one. But the implementation of that plan required all-out cooperation from many individuals and organizations.

The multi-faceted Steering Committee, as listed in the preface of this publication, provided guidance for each of the tasks undertaken. The Steering Committee was chaired by Mr. R. D. (Dick) Spence, Vice

President-Operations of the Southern Pacific Transportation Company. His broad background in the science of railroading and insistence upon detailed explanation of scientific outputs in terms that all railroaders could understand, did much to guide the program and insure that its recommendations would be placed into practice by those concerned.

It was also Mr. Spence, as a member of the AAR Operations-Transportation General Committee, who served as liaison between that governing body and the Program. And it was the O-T General Committee who aided in resolving many of the problems that arose in Phase I.

Certainly, Dr. Greg Martin must be recognized as a major factor contributing to and responsible for the program's success. He was the principal architect in the development of a family of mathematical models that is considered by many to be the most comprehensive ever developed in the industry for the purpose of examining all aspects of dynamic behavior in freight cars. Dr. Martin directed the many people who aided in the development of these models and several of his assistants completed their master's thesis in the process.

Substantial contributions were made by the Railway Progress Institute, the national association of the railway supply industry. These contributions include a cash payment from RPI Reserve Funds accrued from all the some 200 member companies of RPI. They also include company contributions from RPI members, including ACF Industries, American Steel Foundries, Brenco, Inc., Cardwell-Westinghouse, Dresser Transportation Equipment Division, Electro-Motive Division of General Motors, FreightMaster, General Electric, Keystone Railway Equipment Company, Miner Enterprises, Inc., National Castings Division of Midland-Ross Corporation, New York Air Brake Company, Pullman-Standard, and Westinghouse Air Brake Company".

A sizeable proportion of the contributed effort came from the railroads. These included the Atchison Topeka and Santa Fe, Burlington Northern, Canadian National, Canadian Pacific, Chicago Milwaukee St. Paul and Pacific (Milwaukee), Chessie System, Chicago and North Western, Denver & Rio Grande Western, Grand Trunk, Illinois Central Gulf, Louisville & Nashville, Missouri Pacific Lines, Norfolk & Western, Penn Central, St. Louis & San Francisco (Frisco), Seaboard Coast Line, Southern Railway, Southern Pacific Transportation Company, and the Union Pacific.

The Federal Railroad Administration played a major role in Phase I by way of their direct financial aid to the program, by use of their contractors, equipment, personnel, and facilities at the Transportation Test Center in Pueblo, Colorado.

The Transportation Development Agency in Canada contributed to Phase I by underwriting some of the computer time required for developing the Interim Guidelines and which was performed by the Canadian Institute of Guided Ground Transport at Queens University located at Kingston, Ontario.

And finally, we must acknowledge the assistance furnished by Mr. Howard L. Dwyer, Director, and Mr. J. G. Britton, Deputy Director of the AAR Tech Center, for their tremendous efforts in providing facilities for temporary personnel who worked at

different periods at the Tech Center during Phase I,  
in addition to supplying AAR personnel for many hours of  
assistance.

Submitted July 1, 1975, By:

A handwritten signature in black ink, appearing to read "E. F. Lind". The signature is written in a cursive style with a large, prominent loop at the beginning.

E. F. LIND  
PROJECT DIRECTOR  
TRACK TRAIN DYNAMICS RESEARCH  
PROGRAM - PHASE I

INTERNATIONAL RESEARCH PROGRAM

ON

TRACK/TRAIN DYNAMICS

PHASE ONE REPORT

Prepared for the Federal Railroad Administration, Railway Progress Institute, Transportation Development Agency of Canada and Association of American Railroads as a summary of the first phase of a ten-year program.

Detailed in this report are the plans and progress of a joint government/industry program which seeks to identify and solve the dynamic problems confronting railroads in North America.

## TABLE OF CONTENTS

General Background Discussion	1
Steering Committee	6
Program Objectives	9
Phase One Approach	13
Phase One Achievements	27
Bibliography Study	31
Operating Policies	39
Engineer Performance Criteria	61
Reporting System	75
Acceptable Dynamic Train Performance Criteria	93
Interactions and Modelling Studies	99
Mathematical Modelling	101
Component Performance	119
Engineering Test Requirements	127
Train Handling Techniques	133
Special Problems	141
Phase Two Planning	159
Phase One Progress and Conclusions	165
Other Research Program Documents	169



TABLE OF ILLUSTRATIONS

Fig. 1	Administration organization chart	14
Fig. 2	Bibliography organization chart	15
Fig. 3	Operating Policies organization chart	16
Fig. 4	Engineer Performance Criteria organization chart	17
Fig. 5	Reporting System organization chart	18
Fig. 6	Acceptable Dynamic Train Performance Criteria organization chart	19
Fig. 7	Mathematical Modelling organization chart	20
Fig. 8	Component Performance organization chart	21
Fig. 9	Engineering Test Requirements organization chart	22
Fig. 10	Validation organization chart	23
Fig. 11	Train Handling Techniques organization chart	24
Fig. 12	Phase Two Planning organization chart	25
Fig. 13	Special Problems organization chart	26
Fig. 14	Study relationships	29
Fig. 15	Train make-up	45
Fig. 16	Train make-up	45
Fig. 17	Destination blocking	47
Fig. 18	Destination blocking	47
Fig. 19	Lateral forces	49
Fig. 20	Long car/short car combination	51
Fig. 21	Freight car truck components	77
Fig. 22	Curve-worn rail	80
Fig. 23	Accident investigations	84
Fig. 24	Accident investigations	85
Fig. 25	Post processor	113
Fig. 26	Train handling matrix table	139
Fig. 27	Wide gage	142
Fig. 28	Harmonic roll	144
Fig. 29	Superelevation and wheel lift	148
Fig. 30	Truck spacing in harmonic roll situations	150
Fig. 31	Angle of attack	155
Fig. 32	Phase Two organization chart	163

## GENERAL BACKGROUND DISCUSSION

Occasional accidents which disrupt railroad traffic temporarily receive a great deal of attention, from within the industry, from the press, and also from government agencies.

But it is the constant stream of unpublicized, small-scale breakdowns and maintenance problems that create the greater problems over the long term.

And these small-scale problems, if left unattended too long, could develop into the major accidents that command so much attention.

The jolt the conductor notices each time his train reaches a certain speed, the freight that shifts as the train enters a curve, the increasing rail wear that leads to slow orders and lost time and money--all are easily ignored.

But the dynamic problems that plague certain sections of track or combinations of cars, like a chronic illness, wear away at every piece of equipment and each employee on the line. The wear is slight for each wheel, each worker, each rail and tie, but it mounts over time, adding up to heavy losses in productivity, freight damage, equipment breakdown and delays.

Unlike automobiles which develop defects, track and roadbed cannot be recalled to a central point, or several points, for detailed study. Nor has it been the practice or possible to predict through study how a particular railroad car or other piece of equip-

ment will respond under the pressure of constant use.

But industry and government officials concerned with the smooth operation of railroads, both present and future, have determined that such responses and dangers must be studied and analyzed until they become predictable and, hence, avoidable.

The wider variations in soil and terrain conditions within the nations track system, the weight and speeds of the trains that roll over that track and dozens of other factors involved in track/train dynamics are meshed into a seemingly limitless combination of forces and counter-forces that would appear to defy analysis.

Predicting these forces and learning how to avoid, or mitigate, their harmful effects requires a study project of such magnitude as to be beyond the scope of any individual railroad or government agency.

Several studies conducted in the past can be noted, but all covered much narrower areas of difficulty and more specific and immediate problems.

Here, for the first time, a large-scale, systems approach was being proposed. No longer, it was reasoned, could an individual railroad afford to study and solve its own problems.

No single railroad or agency could fulfill the manpower and economic requirements, provide all the expertise or furnish enough test equipment to undertake the project.

Without a joint effort covering all major problem areas on all railroads, cost considerations and the sheer magnitude of data to be

collected and studied would place success far beyond reach.

In July, 1971, the Association of American Railroads (AAR) awarded a contract to the Southern Pacific Transportation Company, commissioning a study of the planning effort required for a track/train dynamics research program.

The Southern Pacific study, completed in early 1972, showed what had been suspected--that the problem was larger than any individual railroad would be able to solve.

The AAR determined then to undertake the research program under its own auspices with the aid of member railroads, the railroad supply industry, and the FRA.

The Federal Railroad Administration (FRA) had indicated an interest in the development of a major test facility, complete with a track loop for dynamic testing. This interest was paramount to the goals of the AAR program and therefore the FRA and AAR determined that it would be best to pool the technical and financial resources of government with the expertise and manpower of the AAR's member railroads in an extensive research effort to solve these problems.

Provision of funds and manpower from the railroad supply industry was conducted by the Railway Progress Institute, through its effective staff and committed membership.

The Railway Progress Institute, representing the nation's railway suppliers, established an ad-hoc committee to explore the possibility of RPI participation in the summer of 1972 under the leadership of then RPI Chairman Donald Y. Clem, President of McConway & Torley Corporation of Pittsburgh. This was followed by unanimous approval of the 40-man Governing Board of RPI on October 12 that the RPI should join the Track/Train Dynamics

Project. The RPI agreed to allocate \$80,000 from its reserve funds to the project with the understanding that the balance of the supply industry's support, both dollars and contributed man hours, would be on a voluntary, company-by-company basis. This has resulted in substantial contributions from the companies listed on Page ii and iii in the "Acknowledgements" section of this report. This RPI entry into the Project was reported by RPI President Nils A. Lennartson in a letter to AAR President Stephen Ailes on October 18 in which RPI was reported "delighted" to join the TTD Project which "We know can be a major step in improving the operations, and, therefore, the service of our nation's railroads".

It quickly became apparent that the problems of track/train dynamics were not unique to the United States. The Transportation Development Agency of Canada also offered assistance and cooperation in the program.

The International Research Program on Track/Train Dynamics was organized in July, 1972, under the management of the Research and Test Department of the AAR. A select steering committee was chosen from the government and industry organizations involved in the project. The AAR, FRA, RPI and TDA all appointed members to the steering committee.

The steering committee was responsible for the establishment of individual studies and the staffing of study groups and for the general operation of the program.

The 16-member panel chose its staff and study group members from AAR and railroad employees, members of the supply industry, staff members of the FRA and TDA and several universities.

If the resources being mustered for this project appear to be immense, it is only because the tasks being undertaken here are equally formidable.

It had to be recognized in this project that railroad freight volume is expected to increase by one-third before 1980, surpassing in yearly volume one trillion ton miles. Also railroads will be required in the next several years to invest substantially in new equipment to handle this increased cargo.

It was expected that as a result of this project, railroads will be able to avoid in their new equipment many of the failings the present equipment is heir to, and to operate all equipment more safely.

The need to avoid breakdowns of equipment was even more acute than usual at a time railroads face a period of increasing demand or decreasing revenues.

To direct the first segment of that research, the steering committee appointed Edward F. Lind, Southern Pacific's project leader in the research program planning study.

Dr. G. C. Martin was appointed deputy project director for this phase.

Under the direction of the steering committee, and with the assistance of the government and industry organizations, the complexities of the track/train dynamic system were addressed.

**THE STEERING COMMITTEE**

Appointed as members of the steering committee for the National  
Research Program on Track/Train Dynamics were:

**CHAIRMAN**

R. D. Spence  
Vice President - Operations  
Southern Pacific Transportation Company

**VICE-CHAIRMAN**

W. J. Harris, Jr.  
Vice President - Research and Development  
Association of American Railroads

M. D. Armstrong  
Chairman  
Transportation Development Agency  
Canadian Ministry of Transport

W. S. Autrey  
Chief Engineer  
Atchison, Topeka and Santa Fe Railway

D. Y. Clem  
President  
McConway & Torley Corporation

L. S. Crane  
Executive Vice President - Operations  
Southern Railway System

J. G. German  
Assistant Vice President - Engineering  
Missouri Pacific Railroad Company

W. S. Hansen  
President  
A. Stucki Company

R. A. Matthews  
Vice President  
Railway Progress Institute

R. G. Maughan  
Chairman  
RAC/TDA Rail Advisory Committee

Leavitt Peterson  
Chief - Rail Systems Division Office of Research and Development  
Federal Railroad Administration

D. V. Sartore  
Chief Engineer - Design  
Burlington Northern, Incorporated

Paul Settle  
President  
Railway Maintenance Corporation

J. B. Stauffer  
Director - Transportation Test Center  
United States Department of Transportation

C. Bruce Ward  
President  
Gunderson, Incorporated

Edward J. Ward  
Acting Associate Administrator - Research and Development  
Federal Railroad Administration



## PROGRAM OBJECTIVES

The study of track/train dynamics is a formidable task, but it can be divided into several sections. In a system approach to the study, each of these sections is a sub-system of the whole.

The system can be divided immediately into two sub-systems--the physical and the operational. The physical sub-system includes the interactions and dynamic capacities of track, cars, locomotives, train consists, and all associated equipment. The operational includes train handling techniques, personnel training, planning and train make-up. All decisions regarding train make-up, handling techniques or other operational practices, however, interact with the physical system.

Through studies of these sub-systems, the relationships between their parts and to each other, the study groups sought to develop improved train handling and make-up techniques, produce new equipment designs and concepts, and develop models through which equipment behavior can be accurately predicted and analyzed.

The project was divided into three phases, lasting two, three and five years, respectively, and began in July, 1972.

Thirteen major study efforts, staffed by personnel from railroads, suppliers, government agencies and universities, were assigned to consider the problems of track/train dynamics in Phase One.

This phase dealt with existing situations. With present equip-

ment, how can trains be handled most efficiently? most quickly? with least deterioration? With present equipment, how do cars and track respond on curves? with heavy loads? with different train make-ups?

If present practices are faulty, they can be corrected. If present equipment needs modification, it can be repaired. If the costs preclude modifications, needed changes can be effected through purchase of improved equipment as the less adequate components are replaced.

Obviously, it would be hazardous to invest in new designs and practices before an understanding of the present situation is obtained, just as it is unproductive to purchase new equipment that suffers the same deficiencies as the old stock.

Therefore, the 13 activities were designed to analyze the dynamic and economic relationships of the sub-systems as a first step toward improving the system as a whole

Phase One included an intense data gathering effort, laying the foundation for the work which will follow. Through laboratory and field tests and thorough information gathering, the Phase One study groups sought to build mathematical models of train and track behavior, increase understanding of the dynamic environment of trains, generate interim train handling and make-up guidelines and define the areas to be studied in later phases.

Phase Two will take the system study a step further, into the area of application. Information and concepts developed in Phase

One will be utilized in the development of new designs and specifications for track, rolling stock and other equipment.

It is here that the mathematical models developed in Phase One become crucial. In the past, equipment criteria were based on relatively simple analyses and static load tests. But a train is effectively a complex series of springs, bars, levers and joints that push, pull, and twist against each other and against the rails on which they roll. More complex criteria, based on more intricate tests, were needed.

An experimental proving ground for new equipment was not available, but production and use of relatively untested equipment introduced problems. These problems could be anticipated through the development of accurate mathematical representations of the forces, counter-forces and dynamic environment of train behavior, which provide a computerized basis for analysis to substitute for a proving ground.

The intended result is the development of equipment that will operate with high reliability and low maintenance costs and to make it possible to design fatigue and flaws out of the system. This becomes possible when we are able to predict where these problems would otherwise occur and establish a basis for improved designs.

When Phase Two is completed, the efforts of the participating organizations will be turned to quantum improvements to the track and train systems.

Phase Three will cover a five-year period in which advanced technology will be utilized in improving these systems. The Phase Three effort is also viewed as a basis for a continuing research program in which technological advances are adapted for railroad use.

## PHASE ONE APPROACH

Preparation and organization are cornerstones to a successful program of study and the track/train dynamics project is no exception to this rule. The mechanism through which such an intricate system will be studied must, by nature, be complex. And its internal workings must mesh as smoothly as the dynamic sub-systems are hoped to do, if the study is to be successful.

The Phase One study was divided into 13 activities, each of which was concerned with a separate aspect of operations or dynamics, and each of which maintained, was related to, or supported one or more other groups.

The 13 tasks can be classified in three basic groups: administration and planning; information gathering; and analysis.

The following is a brief breakdown of the areas covered by the individual task groups:

FIGURE 1.

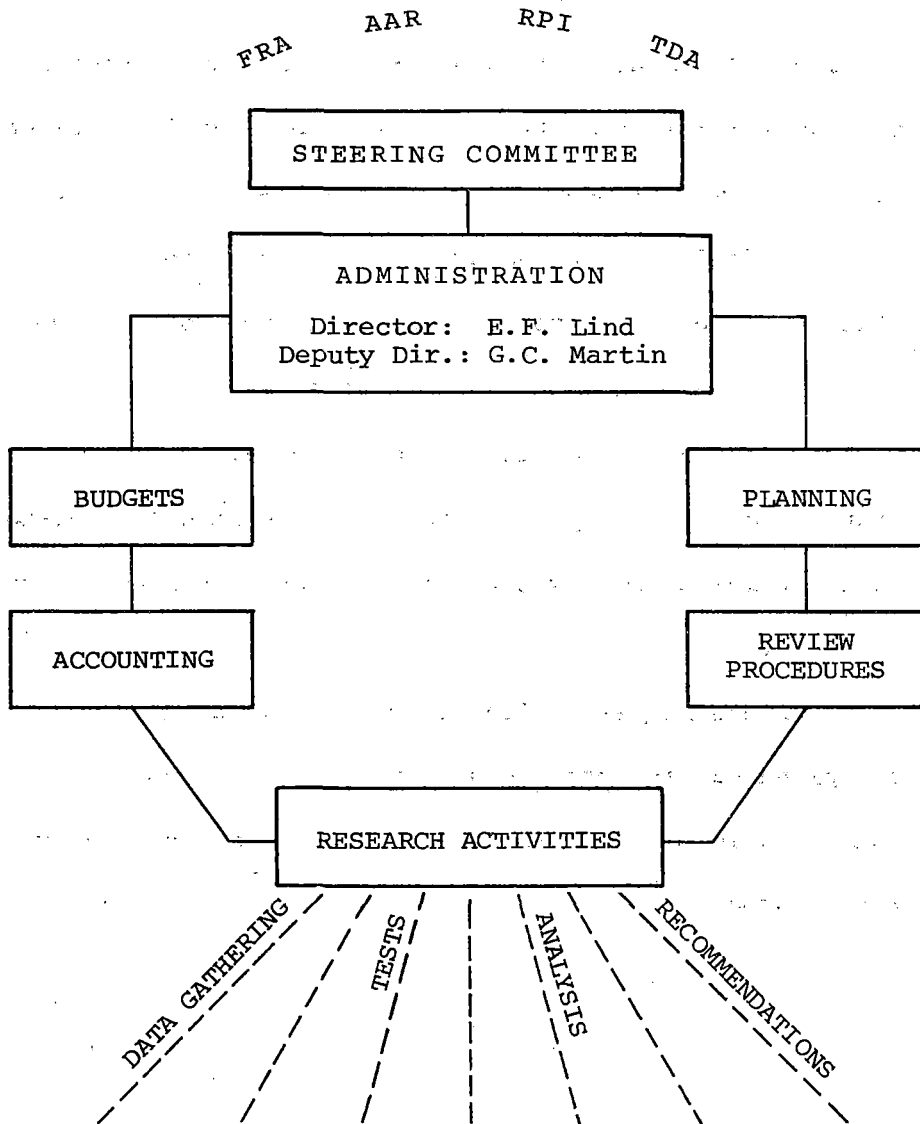

I. Administration

The Administration group developed much of the preliminary plans established accounting procedures, assumed responsibility for economic needs, developed review procedures and maintained a flow of communication among the study groups. The overall responsibility for the program rested with the director.

FIGURE 2.

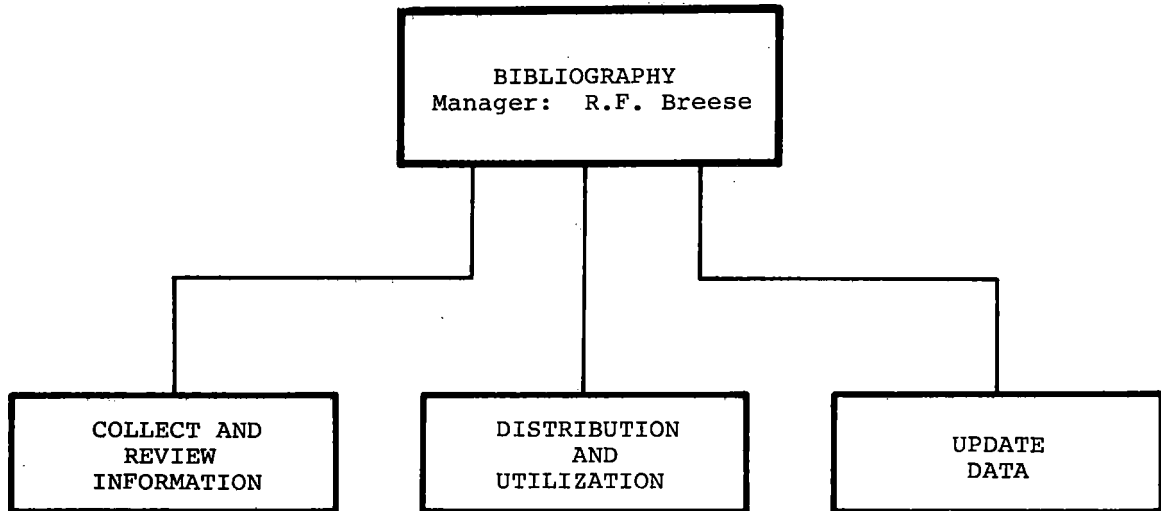

## II. Bibliography

In order to move forward, it is necessary to determine the location of one's starting point. The Bibliography study group was assigned to undertake a continuing effort to locate and disseminate information already available on track/train dynamics.

FIGURE 3.

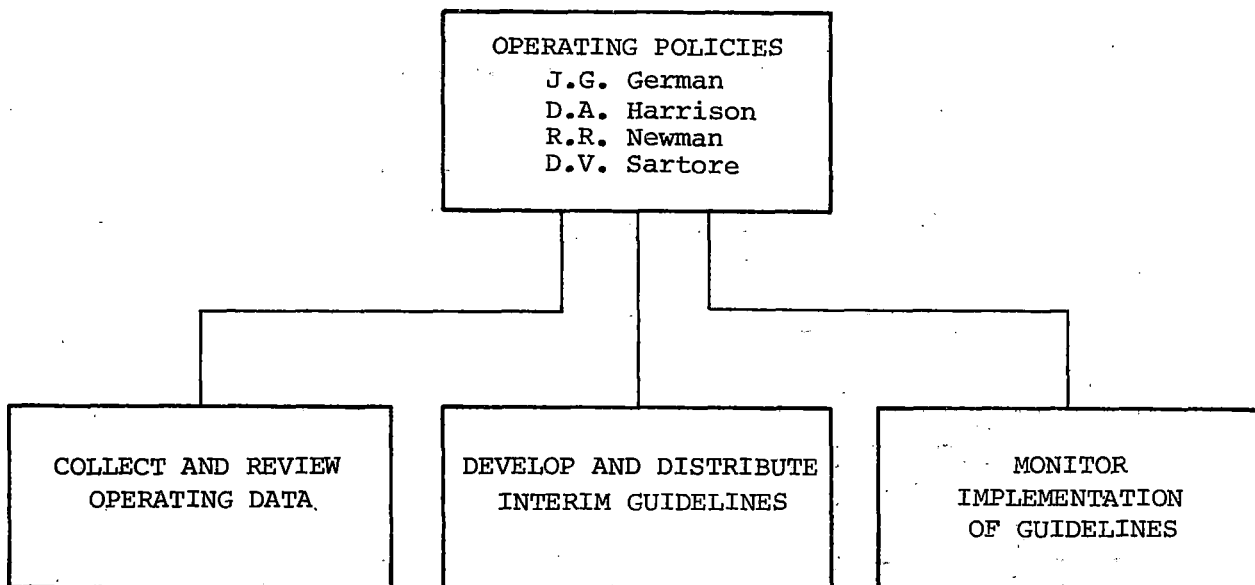

### III. Operating Policies

On the theory that present operations can be made safer by changes in the operation of existing equipment, the Operating Policies group sought to locate and distribute information concerning experience-proven practices already utilized on individual railroads.

The group was also assigned to use this information to develop interim operating guidelines which would serve to mitigate adverse dynamic interactions in the track/train system.

These interim practices were to be based on policies which have proven effective in the past and would continue in use until other studies indicate why the practices are effective and allow the development of even better operating policies.

FIGURE 4.

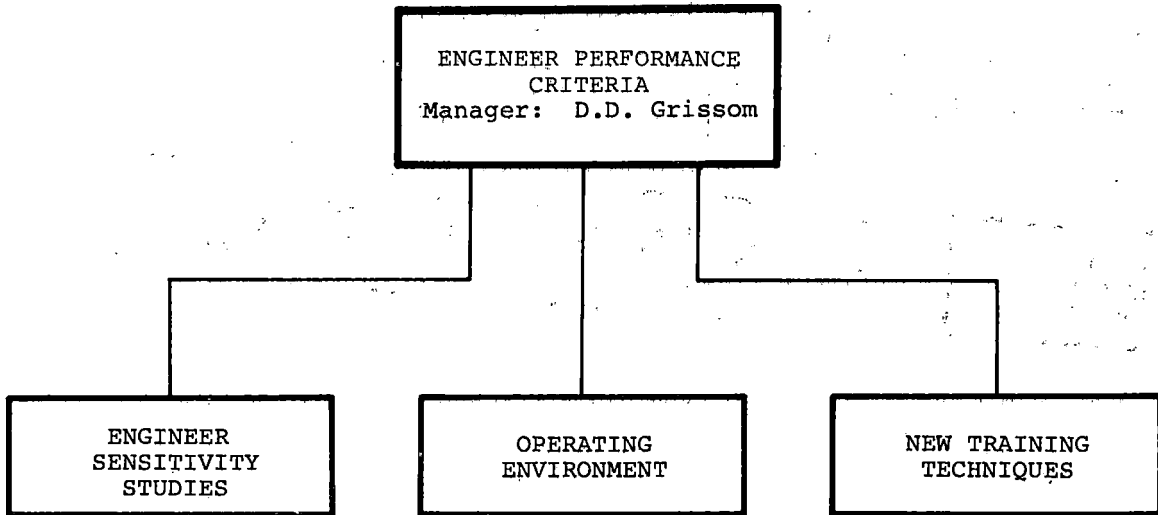

#### IV. Engineer Performance Criteria

The human aspect of train behavior came under scrutiny by the Engineer Performance Criteria group. The group was assigned to study the sensitivity of engineers to changes in speed, shocks, vibrations and other dynamic interactions that occur as the train moves. The engineer's sensitivity to dynamic interactions are related to his ability to handle the train smoothly and respond quickly to dangerous situations.

The group also was assigned to consider the use of new training techniques, engineer qualifications, training tools, including simulators, and increased instrumentation in the cab as methods of improving train handling.



FIGURE 5.

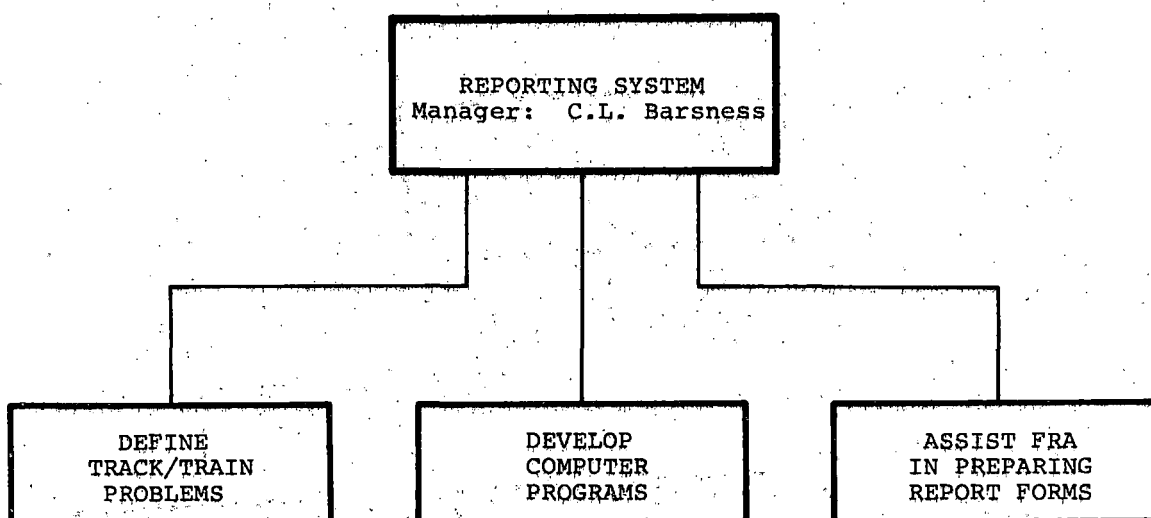

#### V. Reporting System

Just as other agencies utilize coding and classification techniques to aid in pinpointing problem areas, Reporting System personnel assumed the duties of gathering and reporting dynamic track/train problems across the nation. Reporting System personnel developed computer programs to store and classify the data collected and assisted the Federal Railroad Administration in preparing new forms for accident and other reports.

FIGURE 6.

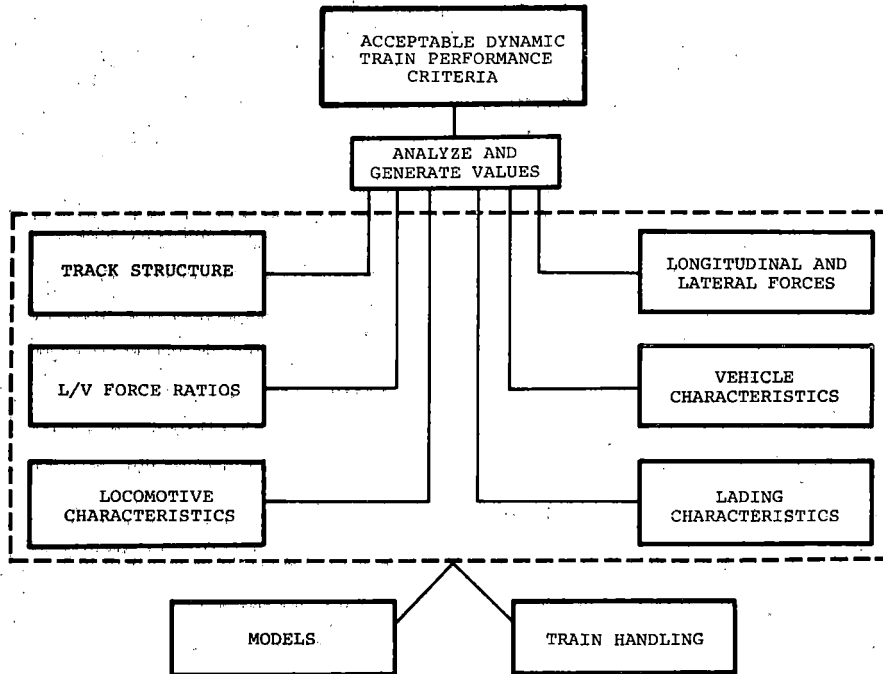

#### VI. Acceptable Dynamic Train Performance Criteria

Acceptable train performance is potentially a vague term, the meaning of which can vary considerably among different railroads. But, if a standard guide to proper train handling is to be developed, a definition of proper train performance is needed.

The Acceptable Dynamic Train Performance Criteria group investigated the train handling techniques which produce a minimum of adverse effects. The risk associated with train operations must also be kept at a minimum in order for performance to be considered acceptable.

The criteria were to be quantified in terms of lateral/vertical force ratios, longitudinal forces, acceleration, and other parameters. These values would then be incorporated into the mathematical models.

FIGURE 7.

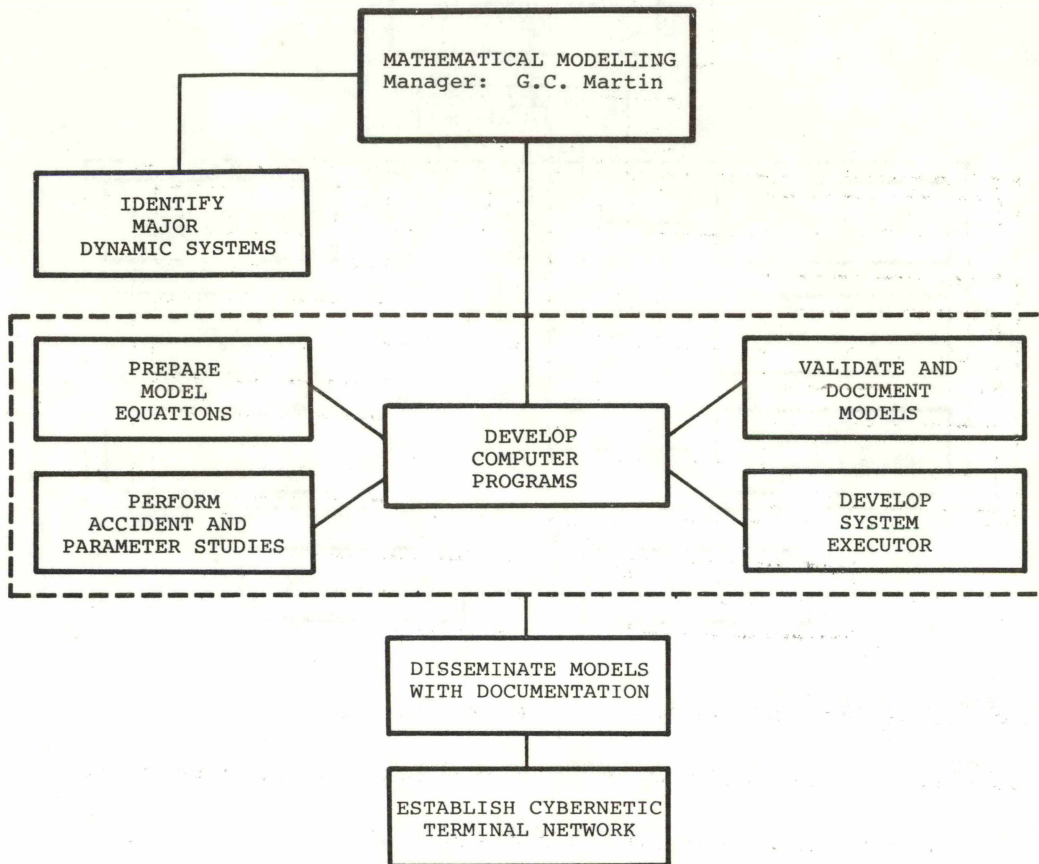

## VII. Mathematical Modelling

As the amount of data obtained from other task groups increased, much of the information entered the domain of the Mathematical Modelling group. To this group went the responsibility for interpretation and study of the dynamic systems and for creation of computer programs which could accurately predict track/train behavior. For this end, the Mathematical Modelling group designed formulae to describe the dynamic behavior of track and train, predict the reliability of track/train systems and to predict the economic impact of alternative systems and solutions.

FIGURE 8.

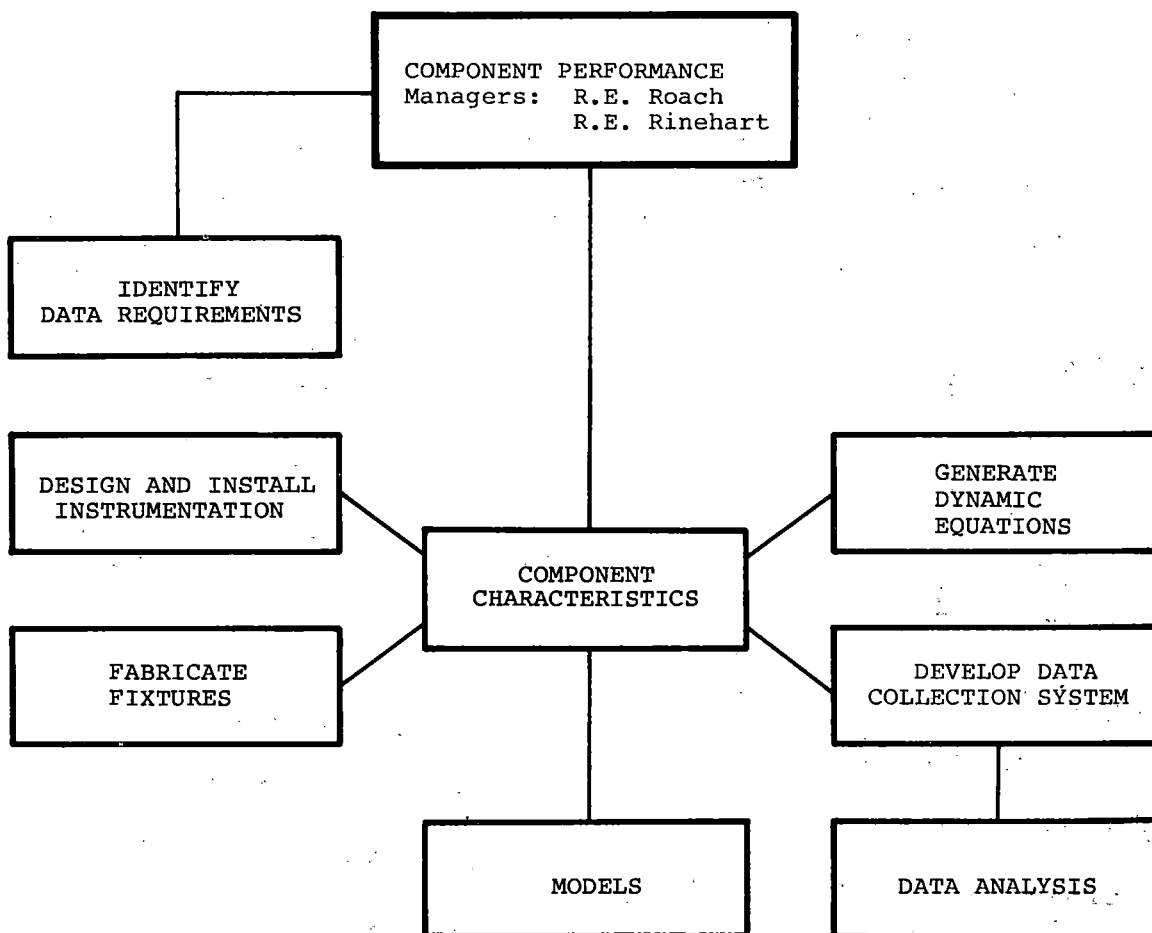

### VIII. Component Performance

The Component Performance study group was assigned to collect experimental data in order to derive an analytical model of a freight truck system and car body combination. The group also was to collect information on vertical and lateral stiffness of track, coupler forces, braking systems and other components.

The information obtained would then be used in the models to analyze curve entry forces, truck hunting, responses to track irregularities and wheel/rail interactions, and other interactions.

FIGURE 9.

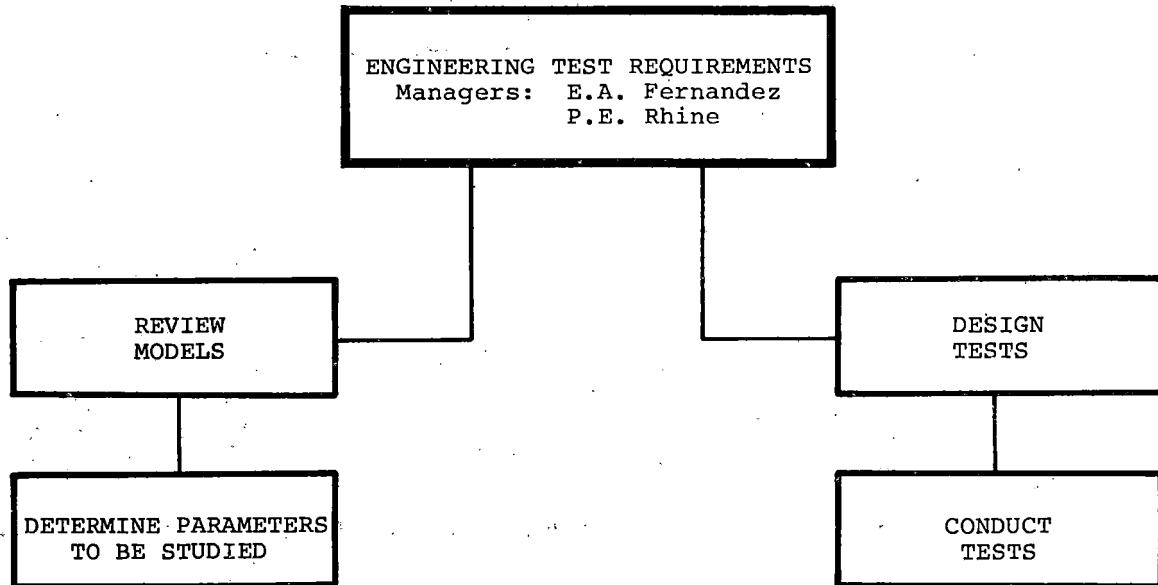

IX. Engineering Test Requirements

Once computerized models of train behavior are developed, they must be validated through the use of accurate data. The Engineering Test Requirements group was assigned to obtain reliable data on the dynamic behavior of track, trains and other components.

The responsibility included both the gathering of data obtained by other study groups and the development of new tests to obtain further information.

This engineering panel determined the parameters to be studied, developed its own study methods and was responsible for the breakdown and analysis of the data collected.

FIGURE 10.

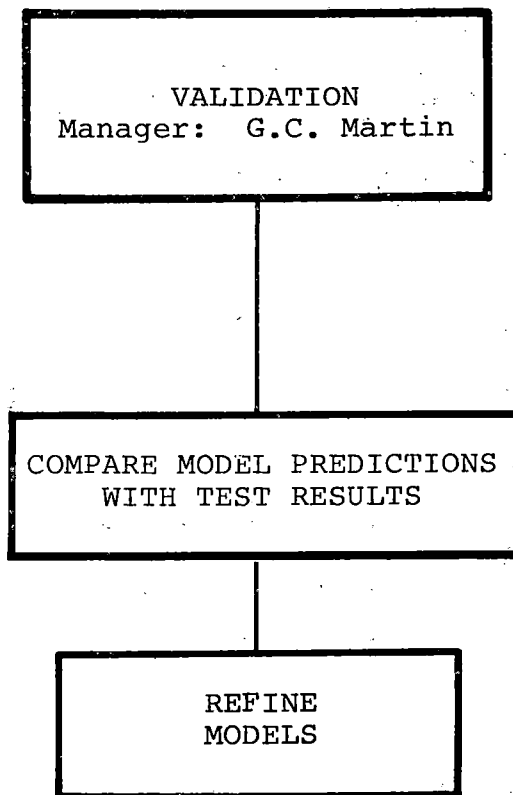

X. Validation

The Validation study, an extension of the Math Modelling and Engineering Test Requirements studies, was to check the formulae developed by the Mathematical Modelling group, in an effort to determine if the models accurately predict the responses of equipment in the real world. The Validation efforts also sought to add refinements to the models to allow them to more accurately reflect and predict real world responses.

This study effort was merged with the Mathematical Modelling and Engineering Test Group.

FIGURE 11.

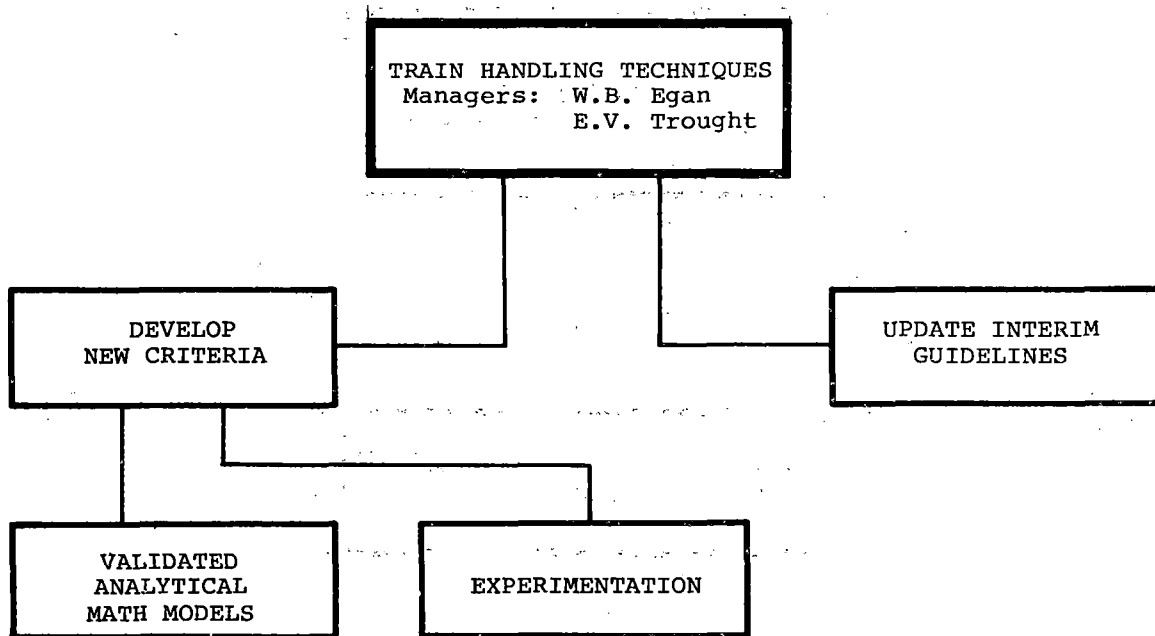

#### XI. Train Handling Techniques

Using the mathematical models and expanding upon the Interim Train Handling Guidelines developed in other sections of the study, the Train Handling Techniques group was assigned to develop a matrix of conditions and proper train handling techniques, for use as a computer input.

The information developed by the Operating Policies group and that group's recommended procedures were to be modified and enlarged upon by the Train Handling Techniques group.

The Train Handling Techniques group was also assigned to study the economic factors involved in train handling techniques and recommend the most effective (economically) methods of operating trains safely.

FIGURE 12.

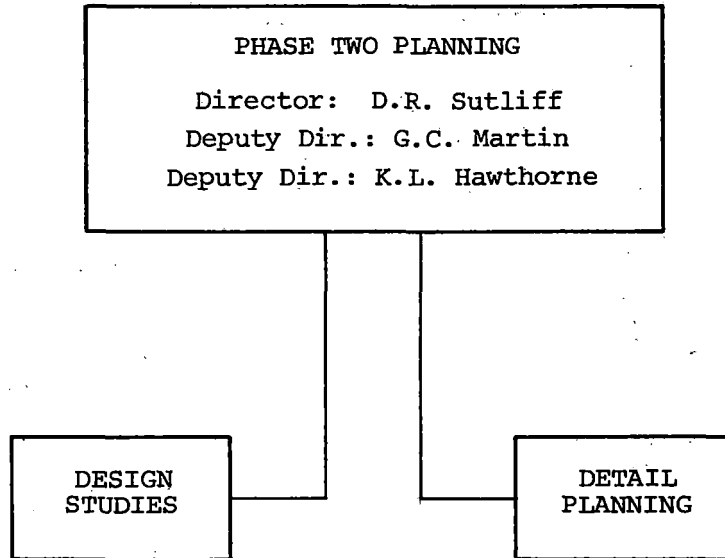

XII. Phase Two Planning

As Phase One projects progressed and information began to be analyzed, the Phase Two Planning group was to begin its determination of the areas and methods of study for the next three years of the project.



FIGURE 13.

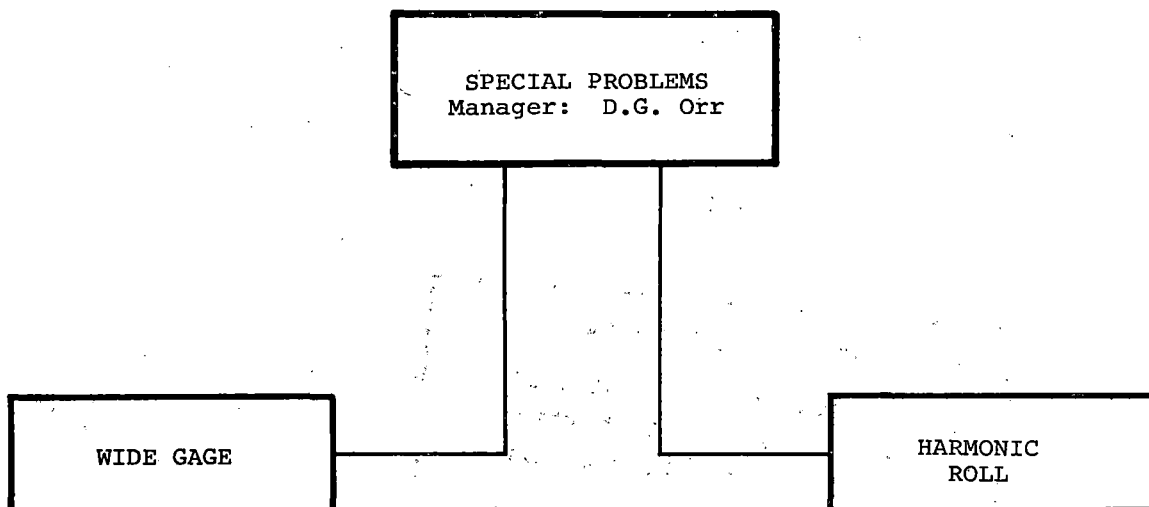

### XIII. Special Problems

The majority of the study groups examined general areas of train performance and dynamic interactions, developing plans for solving and predicting problem situations generally.

But two specific problems were given priority for special studies. Special Problems personnel were assigned to study incidences of wide gage and harmonic roll.

Harmonic roll, the periodic rocking of high-center-of-gravity cars, is responsible for severe cargo shifting and can lead to wheel lift and derailment.

Wide gage, the spreading apart of rails, also leads to derailment.

The Special Problems group sought to determine the dynamic conditions that lead to incidents of harmonic roll and wide gage and to study the locations at which such incidents occur.

## PHASE ONE ACHIEVEMENTS

As shown in Figure 14, the Phase One effort was a group endeavor, depending for its success on the many studies which comprised the total effort.

As shown in the figure, each of the groups fed information or analysis to another group--or several groups--and received information in a similar manner. This pictorial description indicates a portion of the complexities involved in the gathering, circulation and analysis of information in this project.

The achievements of each group were shared by all and were to the credit of each individual involved.

But in discussing these achievements, the volume of material to be digested can become unwieldy. The achievements must be explored one at a time, or in small groups, in order for an understanding to be developed of the whole.

A somewhat arbitrary, but also logical, means of classifying these achievements is to simply discuss them in terms of the study in which they were developed.

The progress of all groups, added together, will be the sum of the progress of the project thus far.

The following, then, is a group-by-group description of the progress of Phase One.

FIGURE 14: STUDY RELATIONSHIPS

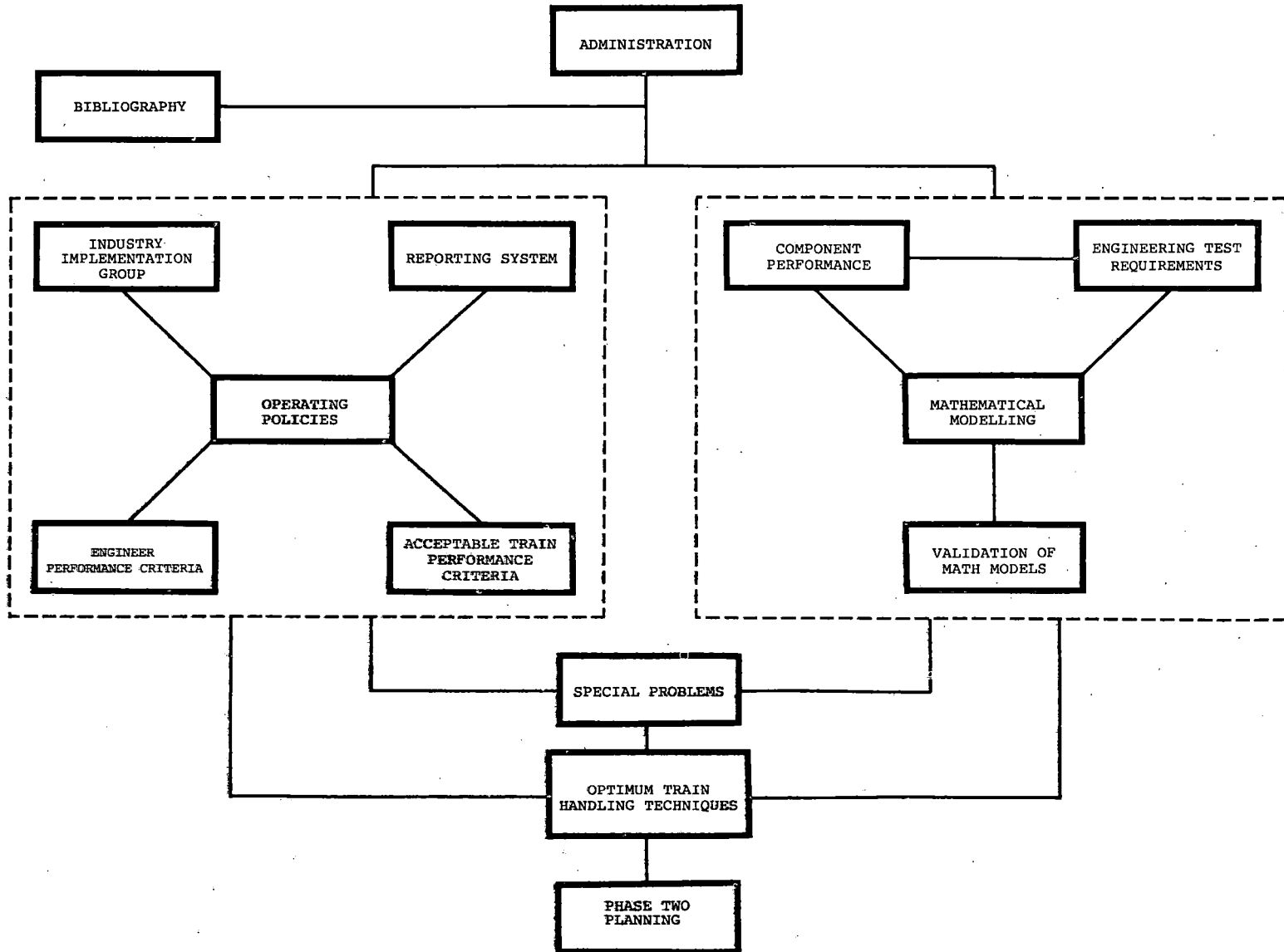

## BIBLIOGRAPHY STUDY

Progress is a vector. It must have direction, not merely magnitude. And it is hoped that progress will take a straight path, that it does not retreat, re-organize and take off in a separate direction.

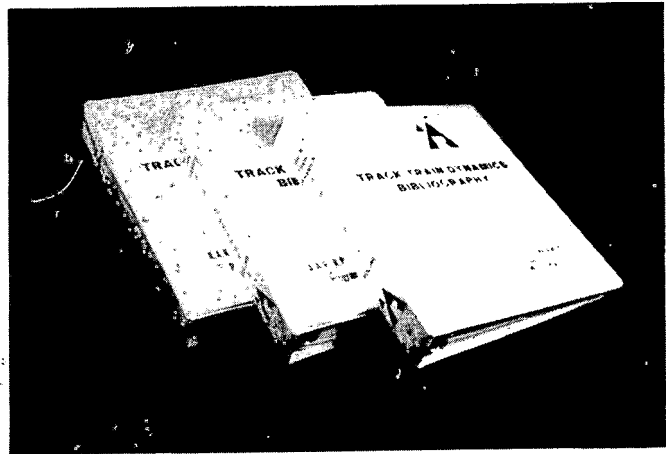

But to begin with direction is to assume a starting point and it is just as necessary to ask what point we are progressing from as it is to ask the direction that efforts will take.

Because of this need, the Bibliography Study was to lay an indispensable foundation for the entire track/train dynamics study effort.

That the group was successful in providing that foundation is evidenced by the Federal Railroad Administration's decision to incorporate the group's findings into its permanent Railroad Research Information System (RRIS).

As mentioned earlier, other studies had been conducted concerning track/train dynamics. These studies were generally more narrow in scope, more limited in time and less widespread in application than the present study was intended to be.

The results of these studies were also less widely circulated,

and known, in the industry at large and by the members of the national research program's study groups, than was considered optimal.

To the Bibliography group fell the task of enlightening and directing other personnel to that section of the foundation already waiting.

Under the direction of Dr. Robert F. Breese, the group analyzed, logged and cross-referenced 600 articles and reference materials at the Association of American Railroads' Research and Test Department Research Center in Chicago.

Beginning in November, 1971, and working through February, 1973, the Bibliography group developed a three-volume bibliography now incorporated into the FRA's Railroad Research Information System (RRIS).

The majority of the research efforts in track/train dynamics, prior to the present effort, had been conducted in England, the European continent, Japan and the United States, Dr. Breese noted.

Within the 763 pages of the original bibliography, the articles are summarized, their publication dates and forms noted, and cross-references supplied.

A thesaurus included in the first volume catalogs and divides categories or refers researchers to key words under which desired information might be found.

The Key Word Index section refers researchers to the articles themselves. Car body aerodynamics, for example, are covered in articles 8006, 8015, and 8018.

Each article carries references to other key words and related studies. The articles are listed in numerical order and cataloged in order in the bibliography section. Numbers assigned to the articles were based on the agency or magazine which developed or printed the study.

The Bibliography will be updated and expanded periodically as part of the FRA's information system.

FROM THE BIBLIOGRAPHY  
(excerpts)

TRACK-TRAIN DYNAMICS BIBLIOGRAPHY

THESAURUS

ACCELERATION(S)

Accelerations, Car Body  
Accelerations, Car Body, Locomotive  
Accelerations, Lateral  
Accelerations, Train  
Accelerations, Vehicle  
Accelerations, Vertical

(ACCELERATION RESISTANCE - SEE RESISTANCE, ACCELERATION)

ACCIDENT(S)

Accidents, Grade Crossing

ACOUSTIC(S)

ACOUSTIC RANGING

(ACTIVE SUSPENSION(S) - SEE SUSPENSION(S), ACTIVE)

ADHESION

Adhesion, Limits (of)

(ADHESION COEFFICIENT - SEE COEFFICIENT OF ADHESION)

AERODYNAMICS

Aerodynamics, Car Body  
Aerodynamics, Tunnel

(AERODYNAMIC BRAKING - SEE BRAKING SYSTEMS, AERODYNAMIC)

(AGE OF EQUIPMENT - SEE EQUIPMENT, AGE)

AIR BRAKE(S) - SEE ALSO BRAKE(S)

AIR FLOW, VEHICLE - INDUCED

(AIR RETARDER - SEE BRAKING SYSTEMS, AERODYNAMIC)

(AIR SPRING(S) - SEE SPRING(S), PNEUMATIC (AIR))

(ALUMINUM FREIGHT CAR(S) - SEE FREIGHT CAR(S), ALUMINUM)

(ANALOG COMPUTER(S) - SEE COMPUTER(S), ANALOG)

(ANALOG SIMULATION - SEE SIMULATION, ANALOG)



TRACK-TRAIN DYNAMICS BIBLIOGRAPHY

KEY WORD INDEX

ACCELERATION(S)

905

Accelerations, Car Body

84

1010, 1046, 1056, 1061

2030, 2051

3001, 3047, 3054

4026

5015

6015, 6018, 6023, 6028

7088

8001, 8004, 8016, 8024, 8037

Accelerations, Car Body, Locomotive

3044

4063

Accelerations, Lateral

1010, 1035, 1055

Accelerations, Train

7083, 7084

Accelerations, Vehicle

1094

8003, 8028

Accelerations, Vertical

1010, 1057

3071

ACCIDENT(S)

Accidents, Grade Crossing

2001, 2023

ACOUSTIC(S)

3061, 3063

5034

8004, 8008

ACOUSTIC RANGING

72

"FREIGHT TRANSPORTATION VIBRATION ENVIRONMENT"

Joint American Society of Civil Engineers -  
American Society of Mechanical Engineers,  
Preprint 1500, Transportation Engineering  
Meeting, July 1971

SUMMARY: The vibration environment to which products are subjected is an important product design element. Usually minor changes in the design of a product or its package will eliminate in-transit damage and hence increase the profits of both the manufacturers and carriers. One major problem to date has been a lack of quantitative data describing this environment in terms usable by the design and packaging engineer.

The major environments to which products are subjected are those created by highway trailers, rail cars, and by trailer-on-flat car movements. The details of each of these environments are presented.

KEY WORDS:

Acceleration  
Environment, Freight Car  
Environment, Highway Truck  
Environment, Vibration  
Lading Dynamics  
Lading Protection  
Package Design  
Suspension Systems

Brissman, D. R.

"RANDOM VIBRATIONS OF A MULTI-WHEELED VEHICLE"

American Society of Mechanical Engineers,  
Paper No. 67-VIBR-60

Anthology of Rail Vehicle Dynamics,  
Volume II, "EFFECTS OF TRAIN ACTION AND RAIL  
CAR VIBRATION," Edited by Guins, S.G. and  
Tack, C.E., Rail Transportation Division,  
American Society of Mechanical Engineers,  
New York, 1972, pp. 167-175

SUMMARY: The vehicle considered is a three-dimensional, N-wheeled vehicle. The speed of the vehicle is assumed constant, and it is also assumed that the wheels maintain ground contact at all times. The suspension system is assumed to be a simple spring-viscous damper system connected in parallel. The spring and damping constants can be varied from wheel to wheel or can be held constant. Power spectral densities are derived for the vertical acceleration of the mass center and for the pitch and roll accelerations of the vehicle. The power spectral density is also determined for the vertical acceleration of any point not at the mass center of the vehicle. The input for the aforementioned equations is the power spectral density of the traversed terrain.

KEY WORDS:

Accelerations, Car Body  
Analysis, Mathematical  
Analysis, Spectral  
Damping Parameters  
Suspension Design  
Suspension Parameters  
Terrain Characteristics  
Track Geometry  
Vibrations, Vehicle  
Vibration Parameters

## OPERATING POLICIES

The National Research Program on Track/Train Dynamics was originally envisioned as a 10-year program of study and development. But normal operating delays could easily extend the end of the program.

And even if the program were completed exactly on schedule, implementation of the study's findings and plans would be a far distance away.

Given that equipment is designed to last several years and that it would be economically impossible for any railroad to summarily dump its stock in favor of improved designs, the changeover to new systems and equipment would be a slow process.

But the dynamic problems facing railroad equipment have been accelerating as quickly as slow orders so the Phase One effort included a study of the means available to use the present equipment more effectively and with less wear and damage.

The Operating Policies study group was assigned to this task. Dozens of railroads operate under hundreds of different procedures, some more efficient than others. Some railroads might have cornered the market on a particular problem, while another group would suffer

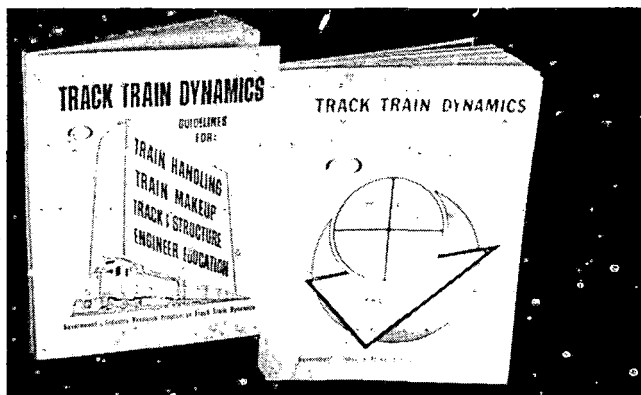

no such effects.

If some railroads suffered fewer dynamic problems than others, or suffered the same problems to a lesser extent, then it must be possible to improve efficiency with present equipment.

Operating Policies group members visited several railroads late in 1972, observing procedures and discussing methods of operation that decreased dynamic problems.

Train handling and train make-up were the key factors considered in the study, although personnel also discussed other problem areas and passed on some of this information to other groups, to help in the refinement of research priorities in other areas of the Phase One effort.

Operating documents and questionnaires and forms were sent to all Class One and Canadian and Mexican railroads and to selected Class Two railroads.

The questionnaires covered handling and make-up problems and response was good. Operating data from more than 120 railroads was received and analyzed. The New York Air Brake Company supplied air brake racks for brake application tests. And graphs were developed from the results of these tests.

Responses were almost too good. The volume of responses and the complexity of operating problems and procedures listed caused several delays in the first six months of the project.

But by the end of April, 1973, the first final draft of the train

handling guidelines had been prepared.

Groups were assigned to write up the Interim Guidelines Manual, which was divided into five sections.

The book of guidelines was sent to the printer in the summer of 1973, organized into five sections, as follows:

1. definitions and functions of equipment
2. train handling
3. train make-up
4. track and structure
5. engineer education

A series of meetings was held in the early months of 1974 to allow railroad officials to discuss and become familiar with the guidelines.

Many of the officials at the meetings indicated they had not previously been aware of much of the material involved and an almost universal comment was that this emphasized the necessity of considering derailments as the responsibility of all departments within a railroad company.

It was noted before the meetings that the guidelines were not a compilation of all procedures currently used in the industry, but summarized the best available train handling techniques presently in use.

Cost-benefit considerations and technical proficiency would naturally be factors in any decision to implement these guidelines

on any individual railroad.

The group was assigned after these meetings to ascertain how many railroads utilized the guidelines and at what costs the guidelines were implemented.

Many of the train handling guidelines are basic--items that are standard operating procedure for experienced engineers.

Section 2.1.2.2 of the guidelines, for example, instructs us that brakes should normally be applied early, so that slowdown and stops do not require a reduction of more than 15 pounds per square inch in air brake lines. These stops tend to develop lower coupler forces than fast stops.

The section advises also that normal freight train stops should be made with as light a brake application as possible, consistent with conditions.

But not all handling techniques, or situations, are that simple and the handling guidelines cover some of the more complex operations.

Section 2.2.1, for example, describes the best way to start a train when heavy cars are located in the rear and lighter cars in the front, or on an ascending grade.

The use of controlled slack and buff in train starts and stops is emphasized in the handling guidelines.

The authors of the guidelines note that the cost of instituting the guidelines would be high, but that the benefits were considered to be greater.

But benefits, such as decreased derailments and equipment and

freight damage, are more difficult to assess than the costs of extra switching and improved train make-up.

Improved train make-up is described in the third section of the guidelines and includes the warning that the best train make-up, that which produces the most stable trains, is also likely to be inconsistent with destination blocking.

In destination blocking, cars are grouped according to their respective terminals. This process facilitates direct delivery to customers, shortened yard time and high car utilization.

But the ideal train make-up requires that heavy cars be placed closest to the motive power and lighter cars farthest from the motive power. This rule holds true no matter where locomotives are located in a train.

The rule appears obvious when considered in light of these facts:

- drawbar forces should not exceed 250,000 pounds,  
in draft or buff.
- drawbar forces are transmitted throughout the  
train and are absorbed by each car.
- heavier cars tend to absorb a greater amount  
of the force than do the light cars.
- light cars tend to decelerate faster than heavy  
cars.
- light cars subject to high drawbar forces are less  
likely than heavy cars to negotiate tight curves.



--drawbar forces are usually lower at cars located furthest from the motive power in heavy grade areas.

Taking all this into consideration, it becomes clear that placing heavy cars near the motive force and light cars far from the motive force will reduce drawbar forces on lighter cars, improve stopping time and provide a more stable train. Figures 15 & 16 illustrate this point by comparing two train consists.

These figures consider the case of a 100-car train climbing a one per cent tangent grade at a constant speed of 40 miles per hour. The average weight per car is 80.5 tons with a range from 31 tons to 130 tons.

FIGURE 15: TRAIN MAKEUP WITH HEAVIEST CARS CLOSEST TO MOTIVE FORCE.

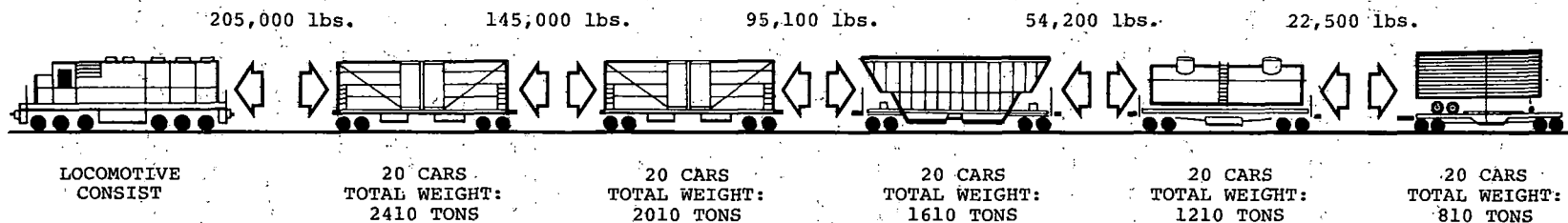

IN THIS EXAMPLE, ONLY 20 CARS EXPERIENCED DRAWBAR FORCES GREATER THAN 145,000 POUNDS.

FIGURE 16: TRAIN MAKEUP WITH LIGHTEST CARS CLOSEST TO MOTIVE FORCE

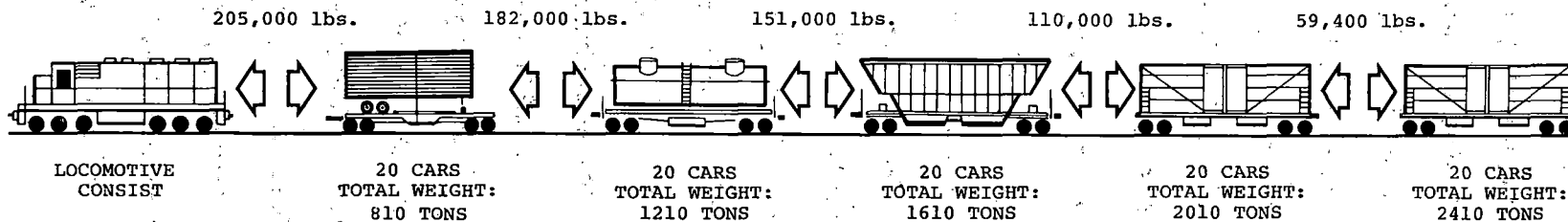

IN THIS EXAMPLE, 43 CARS EXPERIENCED DRAWBAR FORCES GREATER THAN 145,000 POUNDS.

Figure 15 illustrates one of the advantages of making up trains with the heaviest cars closest to the motive power. As shown, with that makeup, the 20th car will transmit 145,000 lbs. of draft drawbar force to the 21st car. But when the lightest cars are closest to the motive power, as in Figure 16, the 43rd car will transmit 145,000 lbs. of draft drawbar force to the 44th car. This means that drawbar forces greater than 145,000 lbs. must be transmitted through an additional 23 couplers to increase by more than 100 per cent the chance for breaking a weak coupler.

As has been mentioned, however, location of individual cars on the basis of their weight is not always economical. So an alternative was explored. This approach, which attempts to reflect engineering as well as economic considerations, will not generally provide the full benefits of optimum mass distribution. But, it represents an improvement over destination blocking, which doesn't take into consideration car weight.

The compromise accepts cars blocked according to destinations. However, the average car weight in each block is then calculated and destination blocks having the highest average weight per car are placed closest to the motive power. Despite such a practice, there may be light cars near-motive power blocks that will experience high drawbar forces. High drawbar forces within a car block can cause problems in case of long car/short car combinations, the short cars usually being lighter.

These figures consider the case of a locomotive consist of four SD-45's with an output of 14,400 horsepower and hauling 114 cars and 5409 trailing tons. The train is travelling at 15 miles per hour constant speed on a 2.5 per cent ascending grade.

FIGURE 17: AVERAGE-WEIGHT DESTINATION BLOCKING

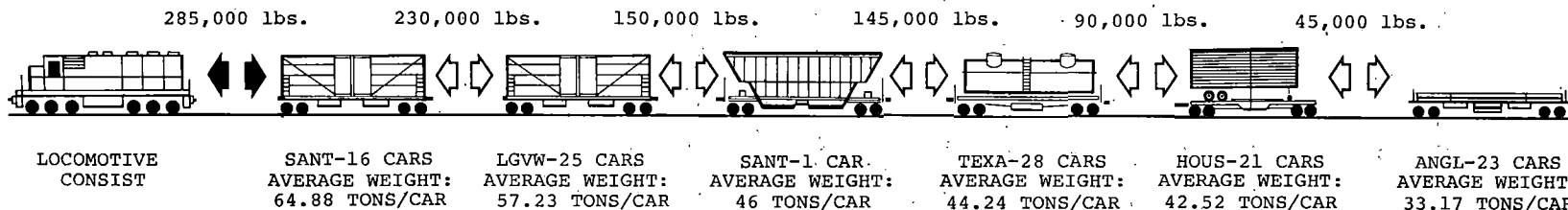

IN THIS EXAMPLE, 16 CARS EXPERIENCE DRAWBAR FORCES GREATER THAN 230,000 POUNDS AND 41 CARS EXPERIENCE DRAWBAR FORCES GREATER THAN 150,000 POUNDS.

FIGURE 18: SIMPLE DESTINATION BLOCKING

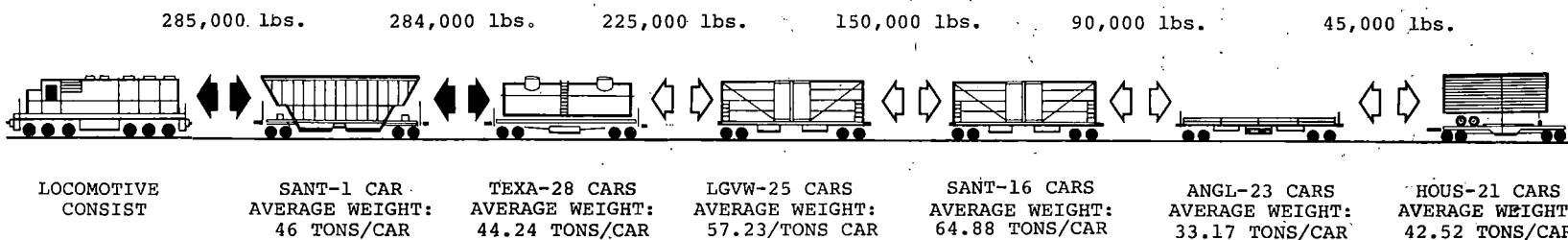

IN THIS EXAMPLE, 27 CARS EXPERIENCE DRAWBAR FORCES GREATER THAN 230,000 POUNDS AND 54 CARS EXPERIENCE DRAWBAR FORCES GREATER THAN 150,000 POUNDS.

Figures 17 & 18 compare drawbar force profiles of a 5,279 ton train powered with four SD-45 locomotives and climbing a 2.5 per cent grade at 15 mph when the train is blocked using destination blocking as opposed to heaviest destination blocks closest to the motive power.

As shown in Figure 18, destination blocking techniques allow 27 cars to experience drawbar forces exceeding 230,000 lbs. But Figure 17 shows that with the heaviest destination blocks closest to motive power, only 16 cars experienced such forces. The compromise approach clearly does not have the full dynamic advantages displayed by single car placement, but it does significantly reduce the number of couplers experiencing excessive drawbar forces.

Another crucial force to be taken into consideration in train handling is the lateral forces between wheel and rail. As shown in Figure 19, the wheel exerts both a lateral and vertical force against the rail and, in cases of sufficiently high lateral forces, a rail can be forced over onto its side.

FIGURE 19: LATERAL FORCES IN CURVES

# LATERAL FORCES

T = THRUST LOAD

f = FRICTION FORCES

K = FLANGE LOAD

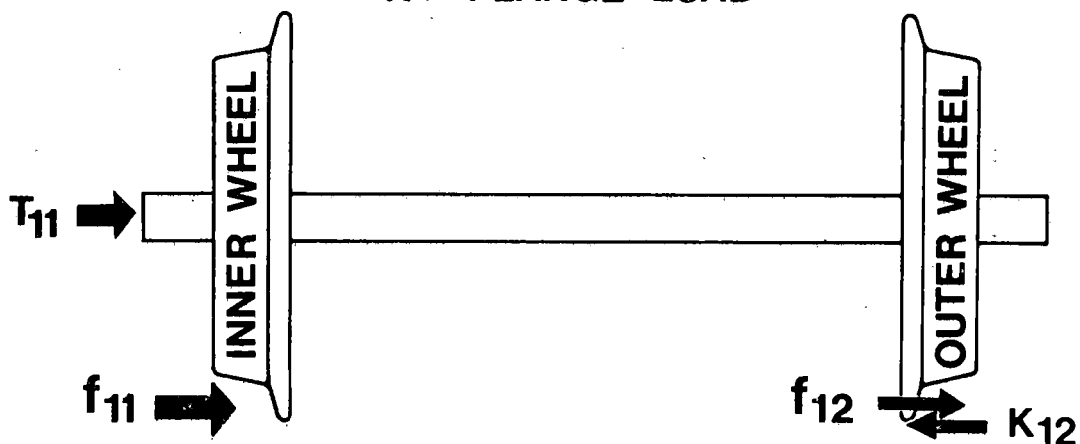

$$\text{NET LATERAL LOAD} = k_{12} = K_{12} - f_{12}$$

These lateral forces can become high on curves with certain combinations of long and short cars. When cars more than 85 feet long, are coupled with cars of less than 50 feet in length, the angular forces on the couplers increase, increasing lateral forces on the rails.

Lateral forces are most critical when negotiating curves. Their magnitude depends directly on degree of the curvature (sharpness) and the geometric configuration of coupled cars. Also lateral forces increase frictional forces, which markedly detract from train performance.

Figure 20 illustrates the geometric configuration of a short car/long car combination and its effect in increasing lateral forces.

As Figure 20 shows, the coupler angle is much greater for the long car than the short car. The resultant lever arm action causes the longer car to experience a much greater lateral force; in the situation illustrated, this force is 23,150 lbs. compared with 12,190 lbs. for the shorter car, and is proportionate to the coupler angle.

FIGURE 20: SHORT CAR/LONG CAR GEOMETRY AND RESULTING LATERAL FORCES

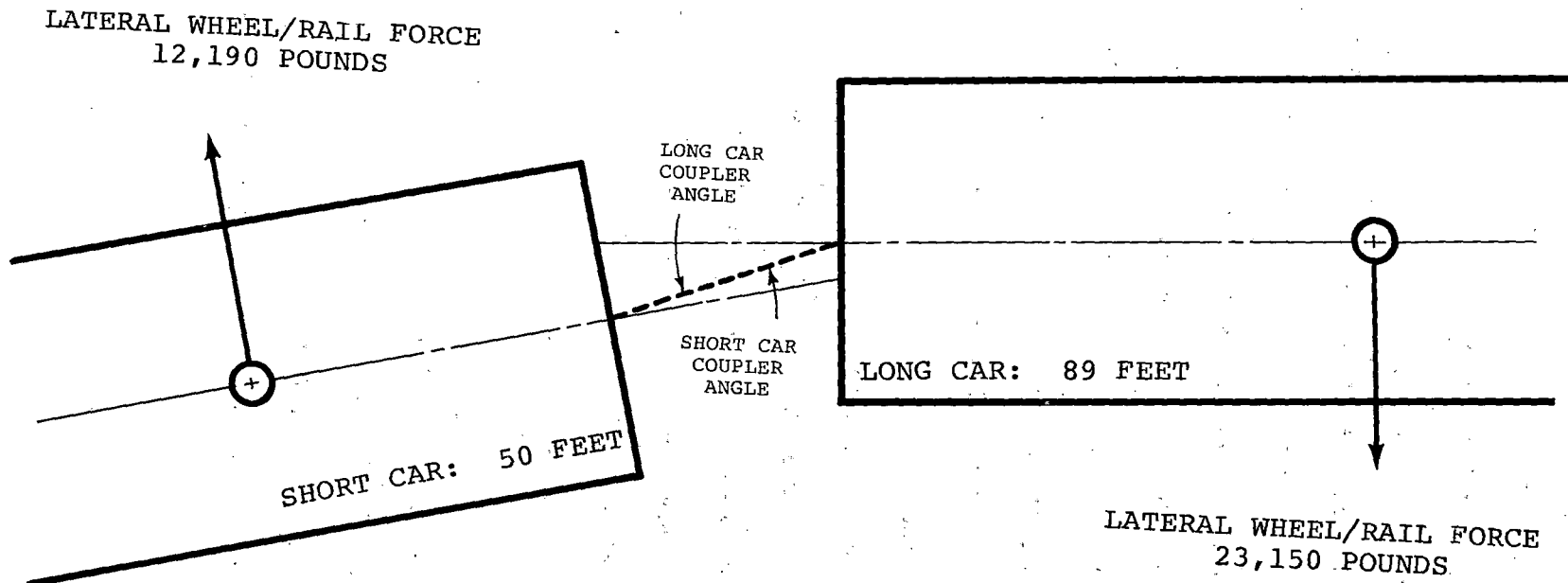



In the situation illustrated, the L/V (lateral/vertical) force ratio for the long car, if empty and weighing 40,000 lbs., would be 0.58, which is close to that which would overturn an unrestrained rail (0.64).

Of course, rail turnover results from several other factors as well, but the increased lateral forces associated with long car/short car combinations is an important consideration.

To offset this effect, the guidelines advise that long car/short car combinations should be placed ahead of helper units.

Special problems, such as dynamically unstable cars and temperature considerations are also discussed briefly in the operating guidelines book.

Basic track structure considerations and engineer training are also discussed in the last two sections.

The authors of the guidelines noted that the economic factors discussed earlier will result in few new applications of the guidelines. But they also noted that many of the guidelines are already in force, in one form or other, on several railroads.

They concluded that the guidelines cover the major areas of operations and will serve as a base from which future operating practices can be developed and judged.

"As these guidelines become more generally understood throughout

the industry and their economic consequences more completely established, a gradual approach toward more stable consists can be expected," the authors state in a special note.

FROM THE INTERIM GUIDELINES  
(an excerpt)

2.1.2.2. USE OF THE AUTOMATIC AIR BRAKE

UNDER NORMAL OPERATION CONDITIONS, A BRAKE APPLICATION SHOULD BEGIN AT A SUFFICIENT DISTANCE SO THAT DESIRED RETARDATION MAY BE OBTAINED BY USING AN INITIAL MINIMUM SERVICE REDUCTION. NORMALLY, SLOWDOWNS OR STOPS SHOULD BE COMPLETED WITH NOT MORE THAN A 15 PSI TOTAL BRAKE PIPE REDUCTION.

THE CONTROL OF SLACK IS ESSENTIAL TO PROPER TRAIN OPERATION AND ANY CHANGES IN SPEED WITHIN THE TRAIN MUST BE MADE SLOWLY TO ALLOW SUFFICIENT TIME TO LET THE TRAIN SLACK ADJUST TO BRAKE APPLICATIONS AND RELEASES UNLESS AN EMERGENCY ARISES.

A. SERVICE BRAKE APPLICATIONS

"SUPER LIGHT" MINIMUM REDUCTIONS SHOULD DEFINITELY BE AVOIDED TO PREVENT "KICK OFF" OF BRAKES. INITIAL BRAKE PIPE REDUCTION SHOULD BE BETWEEN 6 and 8 PSI.

UNDER NORMAL CONDITIONS, THE USE OF A SPLIT SERVICE REDUCTION OR GRADUATED APPLICATION IS THE DESIRABLE METHOD TO BE USED FOR APPLYING TRAIN BRAKES. THIS TYPE OF APPLICATION IS MADE BY MAKING A 6 TO 8 PSI INITIAL REDUCTION, WAITING FOR AT LEAST 20 SECONDS FOLLOWING WHICH FURTHER REDUCTIONS MAY BE MADE AS REQUIRED TO THE POINT OF EQUALIZATION, BEARING IN MIND, HOWEVER, THAT A TOTAL REDUCTION TO EQUALIZATION IF MADE TOO RAPIDLY CAN RESULT IN A HEAVY UNDESIRABLE SLACK SURGE DEPENDENT ON TRAIN MAKE-UP AND GRADE.

WHILE BRAKING, NO FURTHER REDUCTIONS BEYOND FULL SERVICE SHOULD BE ATTEMPTED, EXCEPT EMERGENCY APPLICATION, SINCE THIS WOULD ONLY SERVE TO WASTE AIR AND DEplete THE BRAKE PIPE.

I. THE FOLLOWING PROCEDURES ARE RECOMMENDED FOR STOPPING FREIGHT TRAINS UNDER NORMAL CONDITIONS ON LEVEL TERRAIN:

- a. STOPPING FROM SPEED BELOW 15 MPH WITH "SLACK BUNCHED" METHOD. TO STOP A FREIGHT TRAIN WITH THE AUTOMATIC BRAKE VALVE AT SUCH SPEEDS:

- (1) GRADUALLY REDUCE THE THROTTLE TO IDLE POSITION EARLY ENOUGH TO GENTLY BUNCH THE SLACK INTO THE LOCOMOTIVE, USING THE INDEPENDENT BRAKE TO ACCOMPLISH THIS, IF NECESSARY.
  - (2) COMPLETE THE STOP BY MAKING A LIGHT TRAIN BRAKE APPLICATION OF 6 OR 8 POUNDS HAVING THE LOCOMOTIVE BRAKES APPLIED WHEN THE TRAIN STOPS.
  - (3) USE SAND AS NECESSARY FOR THE LAST 8 OR 10 CAR LENGTHS.
- \* FOR GRADE STOPPING SEE SPECIFIC PROCEDURES SEC. 2.2.1 THRU 2.2.6

b. STOPPING FREIGHT TRAINS OF ALL MAKE-UP EXCEPT THOSE HAVING HEAVY LOADS BEHIND EMPTIES FROM A SPEED ABOVE 15 MPH USING THE "SLACK STRETCHED" METHOD. TO STOP WITH THE AUTOMATIC BRAKE VALVE WHILE WORKING POWER FROM A SPEED OF 15 MPH OR HIGHER, AND BEGINNING AT A POINT FAR ENOUGH IN ADVANCE TO ASSURE THAT THE LOCOMOTIVE WILL NOT PASS THE OBJECTIVE POINT, USE THE FOLLOWING PROCEDURE:

- (1) INCREASE THE THROTTLE ONE OR TWO NOTCHES UNLESS ALREADY WORKING FULL POWER.
- (2) MAKE AN INITIAL BRAKE PIPE REDUCTION OF 6-8 PSI WITH THE AUTOMATIC BRAKE VALVE.
- (3) KEEP THE LOCOMOTIVE BRAKE FROM APPLYING DURING THE INITIAL REDUCTION BY DEPRESSING THE INDEPENDENT BRAKE VALVE HANDLE IN RELEASE POSITION.
- (4) AS THE SPEED BEGINS TO DECREASE, GRADUALLY REDUCE THE THROTTLE ONE NOTCH AT A TIME TO PREVENT THE AMPERAGE FROM INCREASING. IT IS VERY IMPORTANT THAT THE LOAD METER BE OBSERVED AS THE STOP IS BEING MADE TO INDICATE THE CURRENT OR AMPERAGE TO THE TRACTION MOTORS IS NOT EXCESSIVE. THE THROTTLE SHOULD BE IN IDLE POSITION PRIOR TO STOP.
- (5) FOLLOWING PLACEMENT OF THE THROTTLE IN IDLE,

BEGIN LIGHT APPLICATION OF THE INDEPENDENT BRAKE. THE LOCOMOTIVE BRAKES SHOULD BE APPLIED DURING FINAL STAGES OF THE STOP.

- (6) SAND SHOULD BE USED AS NECESSARY FOR THE LAST 8 OR 10 CAR LENGTHS.

\* FOR GRADE STOPPING SEE PROCEDURES SEC. 2.2.1 THRU 2.2.6.

STOPPING FREIGHT TRAINS FROM A SPEED ABOVE 15 MPH USING THE "SLACK BUNCHED" METHOD, ESPECIALLY FOR TRAINS CONSISTING OF LOADS BEHIND EMPTIES OR TRAINS WITH ALL LOADS WHERE THE HEAVIER LOADS ARE CONCENTRATED TOWARD THE REAR. TO STOP A FREIGHT TRAIN WITH THE AUTOMATIC BRAKE VALVE UNDER NORMAL CONDITIONS AND ON LEVEL TERRAIN, WHILE WORKING POWER FROM SUCH SPEEDS:

- (1) GRADUALLY REDUCE THE THROTTLE TO IDLE POSITION TO ALLOW THE SLACK OF THE TRAIN TO GENTLY BUNCH AGAINST THE LOCOMOTIVE. (ALLOW A REASONABLE TIME FOR THE SLACK TO ADJUST.)
- (2) MAKE AN INITIAL REDUCTION OF 6-8 PSI AT A POINT FAR ENOUGH IN ADVANCE TO PREVENT PASSING THE OBJECTIVE POINT.
- (3) IF SPEED PERMITS, ALLOW THE LOCOMOTIVE BRAKES TO APPLY WITH THE TRAIN BRAKES.
- (4) LEAVE THE AUTOMATIC BRAKE VALVE IN THIS POSITION UNTIL WITHIN 200 FEET OF STOPPING AND THEN MAKE A FINAL 6 to 8 PSI BRAKE PIPE REDUCTION, HAVING THE BRAKE PIPE EXHAUST DISCHARGING WHEN THE TRAIN STOPS.
- (5) USE SAND AS NECESSARY FOR THE LAST 8 to 10 CAR LENGTHS.

\* FOR GRADE STOPPING SEE SPECIFIC PROCEDURES SEC. 2.2.1 THRU 2.2.6.

CAUTION: IF THERE ARE INDICATIONS THAT A PARTICULAR TRAIN HAS POTENTIAL FOR AN

EMERGENCY APPLICATION WHEN SLOWING OR STOPPING (DYNAMITER HAS PREVIOUSLY GONE TO EMERGENCY, BRAKE VALVE PROBLEMS, ETC.), THE ABOVE LISTED PROCEDURE "SLACK BUNCHED" METHOD WOULD NOT BE DESIRABLE FOR STOPPING BUT WOULD ADD TO THE PROBABILITY OF TRAIN SEPARATION IF AN EMERGENCY DID OCCUR.

NORMAL FREIGHT TRAIN STOPS SHOULD ALWAYS BE MADE WITH AS LIGHT A BRAKE APPLICATION AS IS CONSISTENT WITH CONDITIONS.

EITHER METHOD OF "STRETCH" OR "BUNCH" BRAKING IS FULLY ACCEPTABLE FOR STOPPING UNDER NORMAL CONDITIONS ON LEVEL TERRAIN AT SPEEDS ABOVE 15 MPH: HOWEVER, JUDGMENT AS TO WHICH METHOD SHOULD BE UTILIZED SHOULD BE BASED UPON THE STATE OF THE SLACK PRIOR TO INITIATING STOP PROCEDURES.

IF HEAVY LOADS ARE LOCATED AT THE REAR OF A TRAIN WITH LIGHT CARS ON THE HEAD END, "BUNCH" BRAKING, UNDER NORMAL CONDITIONS ON LEVEL TERRAIN, APPEARS TO BE THE MOST DESIRABLE METHOD FOR STOPPING.

2. THE FOLLOWING PROCEDURES ARE RECOMMENDED FOR SLOWING FREIGHT TRAINS WITH THE AUTOMATIC BRAKE VALVE UNDER NORMAL CONDITIONS ON LEVEL TERRAIN:

- a. SLOWING USING THE "SLACK STRETCHED" METHOD FOR FREIGHT TRAINS OF ALL MAKE-UPS EXCEPT THOSE HAVING LOADS BEHIND EMPTIES OR TRAINS WITH ALL LOADS WHERE THE HEAVIER LOADS ARE CONCENTRATED TOWARD THE REAR.

- (1) WHILE WORKING POWER, MAKE AN INITIAL REDUCTION OF 6-8 PSI. IF THE INITIAL BRAKE PIPE REDUCTION DOES NOT PROPERLY CONTROL THE SPEED, THEN ADDITIONAL LIGHT REDUCTIONS MAY BE MADE WITH THE AUTOMATIC BRAKE VALVE.
- (2) KEEP THE LOCOMOTIVE BRAKE FROM APPLYING.
- (3) WHILE THE BRAKE PIPE SERVICE EXHAUST IS

DISCHARGING FROM THE INITIAL REDUCTION, LEAVE THROTTLE WHERE IT IS WHILE THE REDUCTION IS BEING MADE. AS THE SPEED REDUCES, GRADUALLY REDUCE THE THROTTLE ONE NOTCH AT A TIME.

- (4) AFTER THE DESIRED BRAKING HAS BEEN ACCOMPLISHED, RELEASE THE TRAIN BRAKES IN ACCORDANCE WITH SEC. B.2. PGS. 2-27 AND 2-28 AND REDUCE THE THROTTLE UNTIL SLACK BECOMES ADJUSTED. REDUCE THE THROTTLE ONE STEP AT A TIME TO PREVENT AMPERAGE FROM INCREASING.
- (5) AFTER THE BRAKES HAVE HAD TIME TO RELEASE, THE SLACK TO BECOME ADJUSTED, AND THE TRAIN HAS PASSED THROUGH THE ENTIRE RESTRICTED ZONE, CAREFULLY ADVANCE THE THROTTLE AND INCREASE SPEED.

b. SLOWING FREIGHT TRAINS OF ALL MAKE-UPS WITH AUTOMATIC BRAKE VALVE; ESPECIALLY THOSE CONSISTING OF LOADS BEHIND EMPTIES OR TRAINS HAVING ALL LOADS WITH HEAVIER LOADS CONCENTRATED AT THE REAR USING THE "SLACK BUNCHED" METHOD.

- (1) GRADUALLY REDUCE THE THROTTLE TO IDLE POSITION TO ALLOW THE SLACK OF THE TRAIN TO GENTLY BUNCH AGAINST THE LOCOMOTIVE.
- (2) MAKE AN INITIAL REDUCTION OF 6-8 PSI WITH THE AUTOMATIC BRAKE VALVE ALLOWING THE INDEPENDENT BRAKE TO APPLY. IF THIS BRAKE PIPE REDUCTION DOES NOT PROPERLY CONTROL THE SPEED THEN ADDITIONAL LIGHT REDUCTIONS MAY BE MADE WITH THE AUTOMATIC BRAKE VALVE.
- (3) AFTER THE DESIRED BRAKING HAS BEEN ACCOMPLISHED, RELEASE THE TRAIN BRAKES IN ACCORDANCE WITH SEC. B.2 PGS. 2-27 AND 2-28.
- (4) AFTER THE BRAKES HAVE HAD TIME TO RELEASE, THE SLACK TO BECOME ADJUSTED, AND THE TRAIN HAS PASSED THROUGH THE ENTIRE RESTRICTED ZONE, CAREFULLY ADVANCE THE THROTTLE AND INCREASE SPEED.

EITHER METHOD OF "STRETCH" OR "BUNCH" BRAKING IS FULLY ACCEPTABLE FOR SLOWING UNDER NORMAL CONDITIONS AND LEVEL TERRAIN. HOWEVER, JUDGMENT AS TO WHICH METHOD SHOULD BE UTILIZED SHOULD BE BASED UPON THE STATE OF THE SLACK PRIOR TO INITIATING SLOWDOWN PROCEDURES. ANY UNNECESSARY CHANGING OF SLACK CONDITIONS TO CONFORM TO EITHER "STRETCH" OR "BUNCH" BRAKING WOULD ONLY SERVE TO INCREASE SLACK ACTION AND COUPLER FORCES.

IF HEAVY LOADS ARE LOCATED AT THE REAR OF A TRAIN WITH LIGHTER CARS ON THE HEAD END, "BUNCH" BRAKING, UNDER NORMAL CONDITIONS ON LEVEL TERRAIN APPEARS TO BE THE MOST DESIRABLE METHOD OF SLOWING SINCE THE NATURAL TENDENCY OF A BLOCK OF HEAVY LOADS WHEN SLOWING WOULD BE TO RUN-IN OR TO BUNCH INTO THE LIGHTER LOADS OR EMPTIES.

A DISTINCT ADVANTAGE OF "STRETCH" BRAKING IS THE FACT THAT, IF EXECUTED CORRECTLY, IT WILL ALLOW AN ENGINEER TO NEGOTIATE MUCH MORE RAPIDLY THE ENTERING AND EXITING OF A PARTICULAR SLOWDOWN OPERATION.

ADDITIONAL TIME MUST BE ALLOWED TO OBTAIN A RELEASE OF TRAIN BRAKES AND RECHARGING OF THE TRAIN BRAKE SYSTEM IF AN OVERREDUCTION HAS BEEN MADE. THIS IS PARTICULARLY EVIDENT WITH LONG TRAINS.

- a. WHEN DESIRING TO MAKE RUNNING RELEASE OF TRAIN BRAKES THE RELEASE OPERATION SHOULD NOT BE STARTED UNTIL THE LAST REDUCTION OF A BRAKE APPLICATION HAS BECOME EFFECTIVE ON THE REAR CAR OF THE TRAIN. A RUNNING RELEASE SHOULD NOT BE ATTEMPTED UNLESS THE BRAKES ON ALL CARS CAN BE FULLY RELEASED BEFORE THE SPEED HAS REDUCED TO NOT LESS THAN 15 MILES PER HOUR FOR TRAINS OF 40-60 CARS, 20 MPH ON TRAINS OF 60-100 CARS, AND 25 MPH ON TRAINS OVER 100 CARS IN LENGTH. HOWEVER, IF THE SPEED OF THE TRAIN CONTINUES TO REDUCE AND IT IS EVIDENT THE TRAIN IS GOING TO COME TO A STOP, A SERVICE BRAKE APPLICATION MUST BE MADE. THE INDEPENDENT BRAKE MAY ALSO BE APPLIED.
- b. UNDER NO CONDITION, AFTER A SLOWDOWN HAS BEEN MADE, SHOULD A RUNNING RELEASE OF BRAKES BE ATTEMPTED UNLESS A TOTAL REDUCTION OF NOT LESS



THAN 10 POUNDS HAS BEEN MADE.

- c. A RUNNING RELEASE SHOULD NOT BE MADE IF THE BRAKE PIPE REDUCTION INDICATES EXCESSIVE LEAKAGE AND SLACK ACTION IS SEVERE.
- d. A RUNNING RELEASE MUST NOT BE MADE ON TRAINS AFTER AN EMERGENCY APPLICATION, NO MATTER HOW HIGH THE SPEED MAY BE.

WHEN MAKING RUNNING RELEASES OF SERVICE APPLICATIONS, IT IS IMPORTANT TO ALLOW SUFFICIENT TIME FOR THE RELEASE OF THE BRAKES THROUGH THE TRAIN BEFORE INCREASING POWER.

## ENGINEER PERFORMANCE CRITERIA

As the Operating Policies group indicated in its report, there are many ways to improve train performance without purchasing new equipment.

The Operating Policies group concerned itself with the specific procedures that work to produce a smooth ride, even wear of equipment and a decrease in freight damage.

But those procedures require, in most cases, a human hand on the throttle or brake. And before any engineer can choose the appropriate response to a dynamics problem, he must first be able to recognize the problem.

The Engineer Performance Criteria study was a two-pronged attack. First, the group sought to determine the effects of experience, familiarity with territory, engineer sensitivity to the effects of dynamic problems and other factors on his ability to handle the train smoothly and respond in emergencies.

Second, the group studied various displays and equipment improvements that could contribute to the engineer's awareness of track/train interactions and therefore improve his responses to these stimuli.

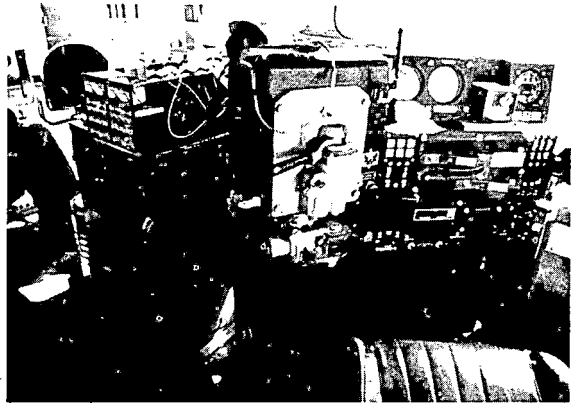

The short term objectives of the Engineer Performance Criteria group involved the development of train handling aids, such as displays and other equipment, which would permit the engineer to know the dynamics of the moving train with a reasonable degree of precision.

The group determined that a set of train handling aids would be installed in a locomotive to determine the extent to which these aids would help an inexperienced engineer to become aware of the response of the train to his actions.

This equipment was to be used in training engineers. Among the training aids considered were:

- an instrumented coupler located behind the locomotive consist, to indicate the forces created by locomotive interaction with cars.
- brake cylinder monitors that show the new engineer the effect of his braking actions in various parts of the train.
- a unit to indicate interactions between wheel and rail, to show the new engineer the effect of incorrect braking and the lateral forces which can lead to derailment.

But first the group needed to know how an experienced engineer functions and the types of forces to expect on a scheduled run.

Southern Railway offered a locomotive and the group began tests in the spring of 1973 on an instrumented train in normal service.

All pertinent information was recorded on magnetic tape for later study. The tape registered nine parameters:

1. acceleration
2. traction motor current (load meter)
3. independent brake line pressure
4. train brake line pressure
5. dynamic configuration
6. throttle position
7. speed
8. events (speed changes, brake applications, etc.)
9. the engineman's voice

The Southern Railway tests were completed before the end of April, 1973, and provided solid baseline information for comparison in other tests.

Another test was not long in coming. During the late spring, the Southern Pacific's Steel Coil Train Test was undertaken. (This test was conducted as part of the Engineering Test Requirements study, but was also utilized to develop data for this one.)

After the data were collected, the group began to formulate the structure of a program directed toward its long-term objective of improving engineer performance.

The Engineer Performance Criteria group settled on four prototype train handling aids, as follows:

1. The train mass distribution graph -- As was noted in the Operating Procedures study, the make-up of a train is an important

factor in determining the dynamic interactions between cars and track. An engineer who has this knowledge can make better decisions in the use of effective train handling procedures.

The group arranged to obtain a Hewlett Packard Company unit that produces a bar graph showing the mass distribution on a train. Each car on the graph is represented as a bar and the height of each bar is proportional to the square of the gross car weight.

2. Draft-Buffer Indicator -- This device is designed to tell the engineer where draft and buff action have developed. The device contains five sensors, mounted after the train is made up. Each sensor transmits either a draft or a buff signal to the cab, where the coupler position is displayed. The DBI was tested in the Steel Coil Train Test and produced good results. In fact, the device indicated some previously unrecognized phenomena. Several times researchers found that sections of the consist were in a draft condition while going downhill. A buff condition would usually be assumed to prevail in such a situation.

The original DBI was developed by TSC and worked with a simple switching device. But a second, more advanced unit, has been developed. The new unit will indicate both the coupler position and the magnitude of the draft or buff forces and will be evaluated when it becomes available.

3. Power consist force display -- This unit displays to the engineer the forces generated by the entire power consist; that is, the equivalent of the draw bar force of the trailing power unit. At present, the engineer has only a loadmeter to establish the load being applied to the consist. A force display unit, however, provides more accurate information from which to estimate dynamic forces occurring within the train.

Production was slowed by a shortage of parts for the display unit, but the wait proved worthwhile. Tests showed the device to be accurate and effective. It has generated a great deal of enthusiasm within the industry. An extensive test program is in progress.

When the unit was first tested, the General Motors test car was placed directly behind the power consist. The power force indicator proved to be nearly as accurate as an instrumented coupler in measuring the drawbar forces at the rear units of the power consist.

In fact, the original device was a bit too accurate. One complaint about the unit was that it contained too much information that was difficult to grasp quickly. So a new unit was designed, with a smoothing function that was more effective than the original as a train handling tool.

4. Single Point Slack Telemetry System -- This unit was connected to the coupler at the caboose to tell the engineer the coupler compression state at the rear of the train and the magnitude of the last shock wave produced through run-in or run-out. The unit also tabulated run-in and run-out incidents and this total could be used as a measure of train handling ability.

The test system performed well, but it was felt that there are other areas of the train at which this type of information is more needed, so the unit was shelved for the remainder of the study.

A fifth unit was developed -- the independent brake monitor. The monitor was designed to provide feedback on the engineer's performance.

The unit was designed to record the amount of time that an engineer spends applying the independent brakes at high speeds. Applications

at high speeds can lead to thermal cracks in wheels.

The group developed an evaluation form for locomotive engineers. The forms seek to quantify information on the skills and abilities of engineers. The forms were designed to help road foremen of engines discover the specific areas in which an individual engineer may need more training.

A special locomotive performance report form was also developed. The form is more comprehensive than earlier forms and an engineer who follows its steps in his inspection process will have a good chance of discovering problems before they become dangerous.

Both of these forms are reprinted at the close of this section.

In early 1974, data runs were conducted to test the accuracy of the engineer evaluation form and indications are that use of the form can lead to a better understanding of the steps required to be taken to improve engineer performance.

It is believed that the results of this study can lead to savings for carriers, although the savings will be hard to quantify because they will be reflected in repairs not required, cargo not damaged, and trains not derailed.

Just as the goal in the Operating Policies study, the goal in this program was to find a way to operate a train safely and efficiently, thus reducing forces in the train and reducing damage to equipment, track, and lading.

By altering operating policies to provide improved responses to various aspects of train behavior and then improving the engineer's sensitivity to those critical modes of behavior, the industry can take a long stride toward better train handling.

As improved operating practices are more widely adopted, train handling aids are installed (in locomotives) to increase sensitivity to undesired train behavior, and these issues are emphasized in training and evaluation of engineers, the benefits of these devices to the industry will mount.



# Locomotive Performance Report

\_\_\_\_\_ Railroad

Location \_\_\_\_\_

Date \_\_\_\_\_ Time \_\_\_\_\_

Weather:  Hot  Warm  Cold  
 Dry  Rain  Snow

## Locomotive Units Initials and Numbers

- Lead \_\_\_\_\_
- 2nd \_\_\_\_\_
- 3rd \_\_\_\_\_
- 4th \_\_\_\_\_
- 5th \_\_\_\_\_
- 6th \_\_\_\_\_
- 7th \_\_\_\_\_
- 8th \_\_\_\_\_
- 9th \_\_\_\_\_
- 10th \_\_\_\_\_

### Mark and complete following applicable items:

#### I. General

Unit \_\_\_\_\_

##### Brakes:

- \_\_\_\_\_ Piston Travel
- \_\_\_\_\_ Misaligned Shoes
- \_\_\_\_\_ Worn Shoes
- \_\_\_\_\_ Hand Brakes
- \_\_\_\_\_ Prescribed Brake Cylinder Pressure

##### Trucks:

- \_\_\_\_\_ Wheels
- \_\_\_\_\_ Flat Spots
- \_\_\_\_\_ Shelled or Cracked
- \_\_\_\_\_ Sharp Flanges
- \_\_\_\_\_ Trucks—Gear Cases
- \_\_\_\_\_ Traction Motor Covers
- \_\_\_\_\_ Loose or Broken Equipment
- \_\_\_\_\_ Missing Equipment
- \_\_\_\_\_ Speed Recorder Equipment
- \_\_\_\_\_ Signs of Overheated Bearings
- \_\_\_\_\_ Unusual Odors

##### Hoses and Cables:

- \_\_\_\_\_ Improperly Connected
- \_\_\_\_\_ Worn or Frayed
- \_\_\_\_\_ Glad Hands

##### Leaks:

- \_\_\_\_\_ Air
- \_\_\_\_\_ MU Connections
- \_\_\_\_\_ Reservoir Blowdowns
- \_\_\_\_\_ Air Leaks in Carbody

##### Liquid

- \_\_\_\_\_ Fuel Oil or Water on underbody or walkways
- \_\_\_\_\_ Couplers and Draft Gear

##### Sanders:

- \_\_\_\_\_ Proper Delivery to Rail

##### Cab and Safety Appliances:

- \_\_\_\_\_ Glass
- \_\_\_\_\_ Hand Rails
- \_\_\_\_\_ Steps
- \_\_\_\_\_ Ramps and Safety Chains
- \_\_\_\_\_ Pilots
- \_\_\_\_\_ Open Hood Doors

- \_\_\_\_\_ Walkway Lights
- \_\_\_\_\_ Fuel Caps
- \_\_\_\_\_ Headlights and Other Lights

##### Cab and Engine Room Inspection:

- \_\_\_\_\_ Coolant
- \_\_\_\_\_ Water Level in Sight Glass
- \_\_\_\_\_ Water Added En Route

##### Supplies

- \_\_\_\_\_ Flagging Equipment
- \_\_\_\_\_ First Aid Supplies
- \_\_\_\_\_ Chains, Knuckles, Hoses and Tools
- \_\_\_\_\_ Fuses and Light Bulbs
- \_\_\_\_\_ Drinking Water
- \_\_\_\_\_ Toilets

##### Radio

##### Safety Controls

#### II. In Power

##### Unit Not Loading

- \_\_\_\_\_ load meter reading \_\_\_\_\_
- \_\_\_\_\_ M.P.H. \_\_\_\_\_
- \_\_\_\_\_ Governor Rack \_\_\_\_\_



Load Regulator (Mark Position of Arm)

##### Engine Speed:

- Idle  Partial  Full

##### Partial Loading Only

- \_\_\_\_\_ load meter reading \_\_\_\_\_
- \_\_\_\_\_ M.P.H. \_\_\_\_\_
- \_\_\_\_\_ Governor Rack \_\_\_\_\_



Load Regulator (Mark Position of Arm)

##### Turbo Pressure Reading

##### Engine Speed:

- Idle  Partial  Full

Over what speed range is unloading experienced? \_\_\_\_\_

##### Not Making Transition

- \_\_\_\_\_ M.P.H. \_\_\_\_\_
- \_\_\_\_\_ Turbo Pressure \_\_\_\_\_
- \_\_\_\_\_ Throttle Position \_\_\_\_\_



Load Regulator (Mark Position of Arm)

##### Wheel Slip Light

- \_\_\_\_\_ Continuous  Intermittent
- \_\_\_\_\_ M.P.H. \_\_\_\_\_

##### Engine Hunting

- \_\_\_\_\_ Throttle Position \_\_\_\_\_
- \_\_\_\_\_ Oil Level in Governor \_\_\_\_\_

##### Engine Overspeed Trips

- \_\_\_\_\_ Unit Overspeed Trips
- \_\_\_\_\_ M.P.H. \_\_\_\_\_

##### Ground Relay

- \_\_\_\_\_ M.P.H. \_\_\_\_\_
- \_\_\_\_\_ Reset \_\_\_\_\_ Times
- \_\_\_\_\_ Throttle Position \_\_\_\_\_
- \_\_\_\_\_ Location \_\_\_\_\_

#### III. In Dynamic Braking

##### No Dynamic Brake

- \_\_\_\_\_ Partial Dynamic Brake
- \_\_\_\_\_ Maximum Amps \_\_\_\_\_
- \_\_\_\_\_ Throttle Position \_\_\_\_\_
- \_\_\_\_\_ M.P.H. \_\_\_\_\_

##### Brake Warning

- \_\_\_\_\_ At \_\_\_\_\_ Amps
- \_\_\_\_\_ Continuous Wheel Slip Light
- \_\_\_\_\_ M.P.H. \_\_\_\_\_

##### Ground Relay

- \_\_\_\_\_ M.P.H. \_\_\_\_\_
- \_\_\_\_\_ Reset \_\_\_\_\_ Times
- \_\_\_\_\_ Throttle Position \_\_\_\_\_
- \_\_\_\_\_ Location \_\_\_\_\_

Continued:



# Locomotive Engineer Evaluation pg.1

Length of Service      Division

Engine Consist	Train	Loads	Empties	Tons
From				

Signature of Examining Officer

Weather

<input type="checkbox"/> Hot	<input type="checkbox"/> Cold	<input type="checkbox"/> Rain
<input type="checkbox"/> Warm	<input type="checkbox"/> Dry	<input type="checkbox"/> Snow

Legend: Y=Yes N=No NR=Not Required

Terminal Preparation	Comments		
1. Punctuality	_____		
2. Bulletin Book Observance	_____		
3. Timetable and Standard Watch	_____		
4. Walk-Around Inspection	_____		
5. Cab Control Check	_____		
6. Locomotive Supply Check	_____		
7. Locomotive Brake Check (Prior to Coupling)	_____		
8. Safe Coupling Speed	_____		
9. Train Brake Test Performance	_____		
10. Communication for Departure Clearance	_____		
11. Performance in Operating Light Engine and Tests	Above Std.	Std.	Below Std.
	<input type="checkbox"/>	<input type="checkbox"/>	<input type="checkbox"/>
12. Knowledge of Brake Test (Conventional)	<input type="checkbox"/>	<input type="checkbox"/>	<input type="checkbox"/>
13. Knowledge of Brake Test (Radio-Train)	<input type="checkbox"/>	<input type="checkbox"/>	<input type="checkbox"/>
14. Summary (Terminal Preparation)	<input type="checkbox"/>	<input type="checkbox"/>	<input type="checkbox"/>

Comments

\_\_\_\_\_

\_\_\_\_\_

Name of Locomotive Engineer

Date

Train Number

<b>Starting</b>	<b>Comments</b>
1. Bell Sounded	_____
2. Whistle Sounded	_____
3. Headlight Burning	_____
4. Monitoring Load Meter	_____
5. Monitoring Air Gauges	_____
6. Speed Observation	_____
7. Concentration of Starting	_____
8. Throttle Handling	_____
9. Use of Independent Brake	_____
10. Use of Sand	_____

**Comments**  
\_\_\_\_\_  
\_\_\_\_\_

---

<b>En Route</b>	<b>Comments</b>
1. Familiarity with Train Orders	_____
2. Relaxed at Controls	_____
3. Observation of Train (Rule 1014)	_____
4. Signal Communication by Name	_____
5. Signal Compliance	_____
6. Proper Use of Whistle	_____
7. Handling of Headlight	_____
8. Use of Radio	_____
9. Reporting Defects (Track, Bridges, Signals, etc.)	_____
10. Knowledge and Compliance with Form Y Train Order	_____

# Locomotive Engineer Evaluation pg.3

Name of Locomotive Engineer

En Route (Continued)	Comments
11. Handling Throttle at Crest of Hill	_____
12. Avoids Applying Brakes While Passing Over Bridges and Trestles	_____
13. Handling of Air Brakes with Dynamic Brakes Operative	_____
14. Handling of Air Brakes with Dynamic Brakes Inoperative	_____
15. Knowledge and Handling of Brake Valves During Train Separation	_____
16. Applying Dynamic Brakes at Proper Location and Proper Time Delay	_____
17. Releasing Dynamic Brakes at Proper Locations	_____
18. Knowledge and Handling of Dynamic Brakes Entering Sidings and Crossovers	_____
19. Dynamic Brake Handling Prior to Stop	_____
20. Compliance with Authorized Speeds	_____
21. Knowledge of Authorized Speeds	_____

	Above Std.	Std.	Below Std.
22. Acceleration of Train	<input type="checkbox"/>	<input type="checkbox"/>	<input type="checkbox"/>
23. Observation of Track Conditions	<input type="checkbox"/>	<input type="checkbox"/>	<input type="checkbox"/>
24. Familiarity with Terrain	<input type="checkbox"/>	<input type="checkbox"/>	<input type="checkbox"/>
25. Judgement of Location of Rear of Train	<input type="checkbox"/>	<input type="checkbox"/>	<input type="checkbox"/>
26. Consideration of Slack and Terrain	<input type="checkbox"/>	<input type="checkbox"/>	<input type="checkbox"/>
27. Ability to Control Slack	<input type="checkbox"/>	<input type="checkbox"/>	<input type="checkbox"/>
28. Ability to Plan Ahead	<input type="checkbox"/>	<input type="checkbox"/>	<input type="checkbox"/>
29. Knowledge of Changing Operating Ends	<input type="checkbox"/>	<input type="checkbox"/>	<input type="checkbox"/>

Date

<b>En Route (Continued)</b>	<b>Above Std.</b>	<b>Std.</b>	<b>Below Std.</b>
30. Knowledge and Handling of Picking Up and Setting out Locomotives and Required Air Tests	<input type="checkbox"/>	<input type="checkbox"/>	<input type="checkbox"/>
31. Monitoring of Gauges and Controls	<input type="checkbox"/>	<input type="checkbox"/>	<input type="checkbox"/>
32. Independent Air Brake Use	<input type="checkbox"/>	<input type="checkbox"/>	<input type="checkbox"/>
33. Handling of Train Air Brakes	<input type="checkbox"/>	<input type="checkbox"/>	<input type="checkbox"/>
34. Handling of Throttle when Braking under Power.	<input type="checkbox"/>	<input type="checkbox"/>	<input type="checkbox"/>
35. Ability to Control Slack when Using Air Brakes	<input type="checkbox"/>	<input type="checkbox"/>	<input type="checkbox"/>
36. Knowledge and Handling of Air Brakes when Picking Up, Setting Out, and Air Brakes	<input type="checkbox"/>	<input type="checkbox"/>	<input type="checkbox"/>
37. Handling Dynamic Brake Application	<input type="checkbox"/>	<input type="checkbox"/>	<input type="checkbox"/>
38. Summary (En Route)	<input type="checkbox"/>	<input type="checkbox"/>	<input type="checkbox"/>

**Comments**

---



---



---



---

<b>Stopping</b>	<b>Comments</b>
1. Immediately Complies with Instructions and Stops His Train when Notified of Hot Journal or Other Defects	<hr/>
2. Complies with Rules When Pusher Engine Couples to Train	<hr/>
3. Yards Train Efficiently	<hr/>
4. Secures Unattended Locomotives	<hr/>
5. Walk-Around Inspection	<hr/>
6. Properly Fills Out Work Report	<hr/>
7. Registers Promptly	<hr/>

# Locomotive Engineer Evaluation pg.5

Name of Locomotive Engineer

<b>Stopping (Continued)</b>	Above Std.	Std.	Below Std.
8. Judgement in Stopping	<input type="checkbox"/>	<input type="checkbox"/>	<input type="checkbox"/>
9. Summary (Stopping)	<input type="checkbox"/>	<input type="checkbox"/>	<input type="checkbox"/>

**Comments**

---



---

<b>Attitude Summary</b>	Above Std.	Std.	Below Std.
1. Safety	<input type="checkbox"/>	<input type="checkbox"/>	<input type="checkbox"/>
2. Teamwork with Crew and Others	<input type="checkbox"/>	<input type="checkbox"/>	<input type="checkbox"/>
3. Reaction to Instruction	<input type="checkbox"/>	<input type="checkbox"/>	<input type="checkbox"/>
4. Reaction to Criticism	<input type="checkbox"/>	<input type="checkbox"/>	<input type="checkbox"/>
5. Knowledge of Locomotive	<input type="checkbox"/>	<input type="checkbox"/>	<input type="checkbox"/>
6. Knowledge of Special Instructions	<input type="checkbox"/>	<input type="checkbox"/>	<input type="checkbox"/>
7. Knowledge of Normal Procedures	<input type="checkbox"/>	<input type="checkbox"/>	<input type="checkbox"/>
8. Knowledge of Emergency Procedures	<input type="checkbox"/>	<input type="checkbox"/>	<input type="checkbox"/>

**Comments**

- 9. Physical Condition 

---
- 10. Reaction Time 

---
- 11. Coordination 

---
- 12. Mental Processes 

---
- 13. Medication 

---

Date

**Overall performance on this run.** Consider his overall competence in handling the train and equipment. Consider his ability to perform without your help, his knowledge of the job, his skill in train handling. Place an x in the box which indicates your overall judgment.

Above Std.       Std.       Below Std.

**Comments**

---



---

## REPORTING SYSTEM

As we have seen from the findings of the Operating Policies and Engineer Performance Criteria studies, there are many ways to operate trains, some more desirable than others, and there are many dynamic situations to which an engineer must respond.

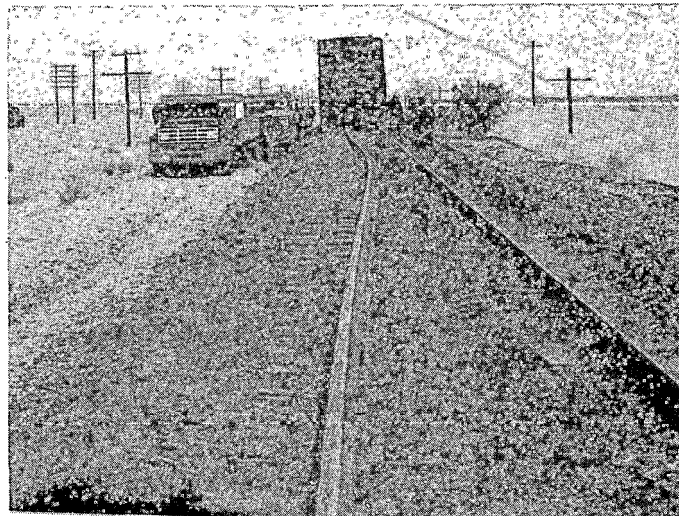

The choice of operating procedures does not depend solely on the make-up of a train, or the level of the track, or the coupler compression state. Rather, the proper procedures can be chosen only after consideration of all these factors, and not from consideration of a single condition.

But if selection of proper operating techniques requires attention to several interacting factors, then an improper choice can have adverse effects on train response.

A derailment is generally caused by a combination of factors--speed, rail wear, weather and track conditions, etc.--interacting to produce enough force to lift a wheel from the rail or cause a rail to rollover.

In understanding these relationships lies the key to preventive action in regard to derailments. The Reporting System group was assigned to develop sufficient understanding of the derailment phenomenon so that a proper reporting system could be developed.

The study has yielded many results, including an 83-page manual



titled "Accident Investigation."

The manual is based on the assumption that many derailments are a complex form of track/train dynamics and states that most previous derailment investigation policies have under emphasized interactive effects by insistence on the search for a single accident cause. The manual states on page vi of the introduction:

"This type of accident is defined as one caused by the interaction of two or more factors which, had they occurred independently, would not have resulted in the accident. The recognition that derailment may be combination-caused--rather than mandating the investigators to report a single cause--is necessary if the information reported from the accident situation is to more accurately reflect the true situation."

Many combinations of dynamic factors exist;--some are inconsequential and some extremely dangerous.

As an illustration of the number and complexities of these combinations, the manual discusses the major components of a freight car truck. Five components are listed: the front and rear wheel sets (wheels and axle), the left and right side frames and the truck bolster. Each of these can move independently along vertical or horizontal axes or rotate about either of these axes.

These components are illustrated in Figure 21.

FIGURE 21: FREIGHT CAR TRUCK COMPONENTS AS FACTORS  
IN FREIGHT CAR DYNAMICS

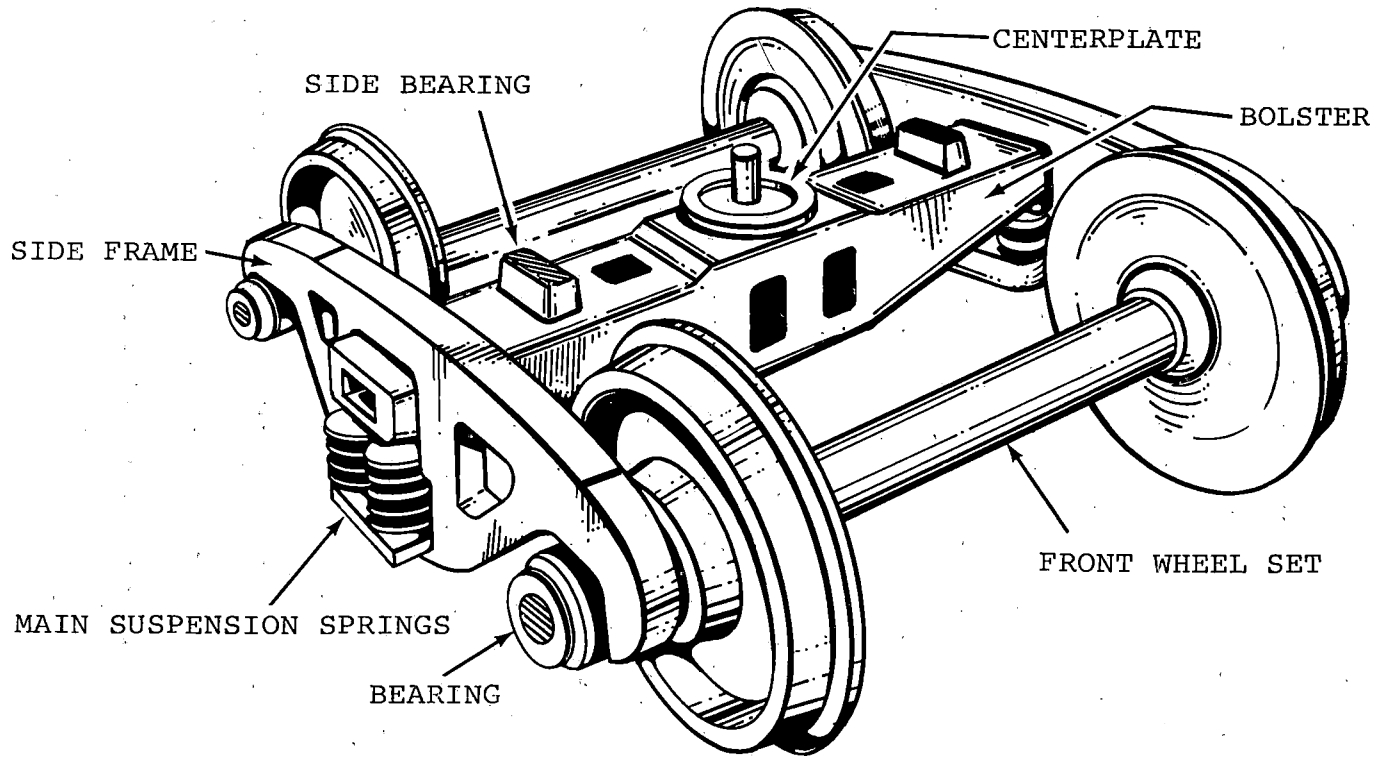

Those five components, multiplied by four degrees of freedom yield 20 degrees of freedom for a truck. Add another 20 degrees of freedom for the second freight car truck.

Then consider the car body. The body can move along three axes (longitudinal, lateral and vertical), in relation to the motion of the wheels and train as a whole, and it can rotate about any or all of these axes at the same time.

Adding these degrees of freedom brings the total number of possible motions to 46. Consider that several of these actions will occur simultaneously and the number of combinations of motions can be seen to be very large.

The addition of wheel/rail interactions adds even more factors. But if these interactions give rise to conditions that lead to derailments, they must be understood. Derailments may occur in the absence of improper train handling. In these cases, the causes may be sought in the complexities of dynamic interactions.

Accident Investigations is a manual, a how-to book for accident crews and trouble-shooters. It provides an informative look at the causes of derailments and the means by which these causes can be identified in the aftermath of the accident.

The book discusses key factors affecting train behavior, such as adhesion, wheel/rail interactions, curve-worn rail, etc.

Adhesion is simply the longitudinal friction force between wheel and rail and is the means through which the turning of the wheel is translated into the motion of the train.

The greater the adhesion between the wheel and rail, the more control the engineer has over the speed, acceleration and braking of the train.

Water, oil or other foreign materials on the rail surface reduce adhesion and adhesion always decreases on curved track. Rail profile, speed and weight shifting in cars can also affect adhesion.

The lateral/vertical force ratio, as will be discussed further in later sections, is a key in wide gage derailments, wheel climb, and rail rollover.

Lateral/vertical force ratios are affected by speed, weight and geometry of car, and its components, track curvatures, draft and buff forces and train make-up, among other factors.

Curve-worn rail is not a force of any type, but it is a consistent factor observed in many train derailments. Curve-worn rail has rarely been found to be the single cause of a derailment. A broken rail or high L/V force ratio can cause derailments in the absence of other forces (although it should be noted that L/V ratios are the result of complex factors). But curve-worn rail is a significant incremental factor which can permit a derailment to occur that would not occur on new rail.

The manual recommends that field officers develop an increased awareness of curve-worn rail as an influencing factor in derailment. The manual also concludes that the optimum wheel/rail configuration is not yet known, as evidenced by a study of curve-worn rail, and that a better configuration, one that is prone to less wear, may be developed through further study.

FIGURE 22: CURVE-WORN RAIL

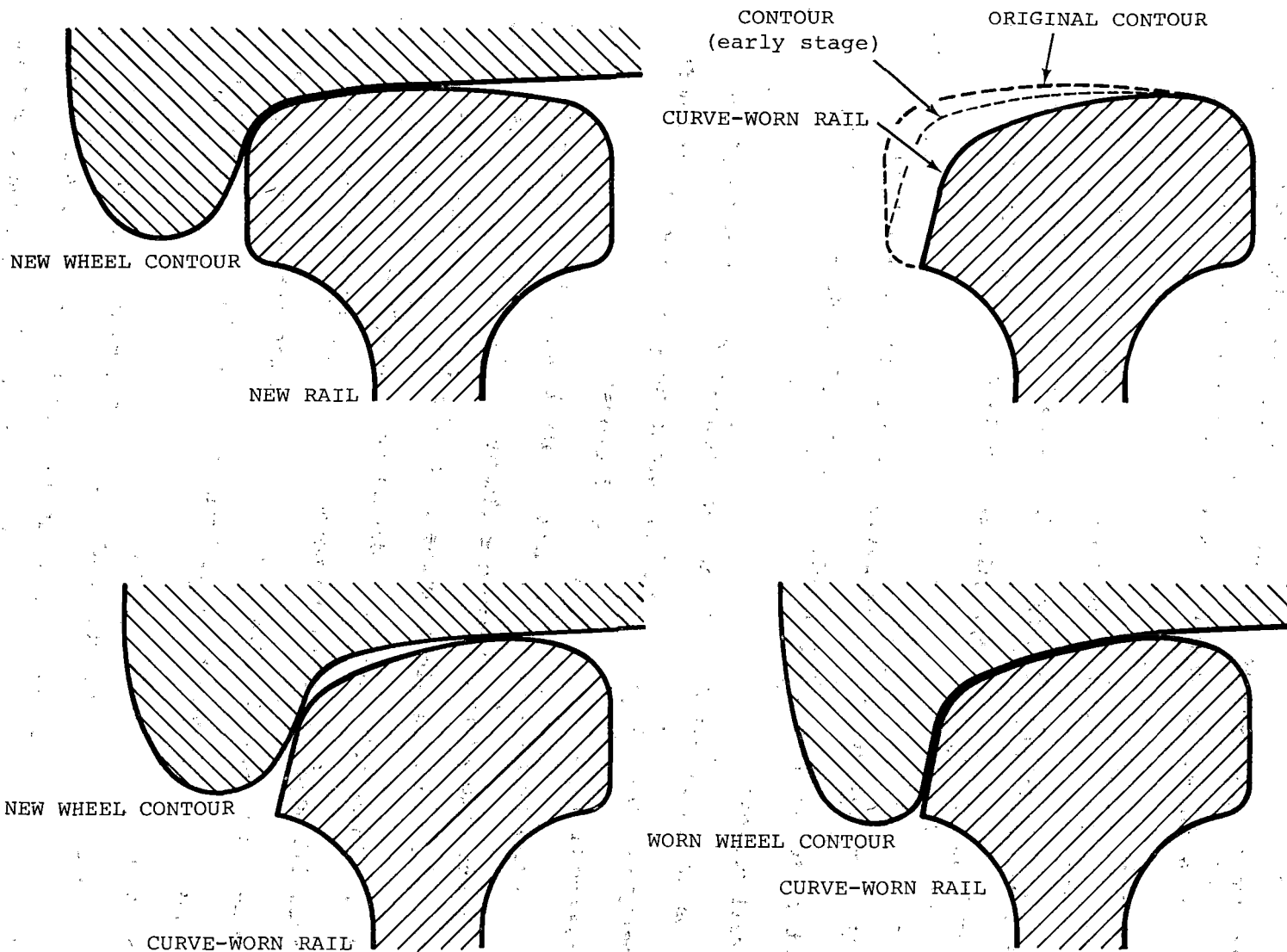

Figure 22 indicates the common appearances of curve-worn rail.

The manual notes that extra maintenance consideration is needed on curves and in areas where traffic or tonnage have increased significantly. These are areas particularly susceptible to increased serious rail wear.

As was recommended by the Operating Policies group, the manual suggests operating policies be adopted that will reduce high draft and buff forces on curves as a means of reducing high L/V ratios.

And last, the manual provides advice on how to organize a derailment investigating team and how to conduct these investigations.

The Reporting System group was assigned both to study train accidents and to report on trends in accident causes and occurrences.

Reporting System researchers familiarized themselves with the reporting requirements of the FRA and AAR and then visited several railroads that utilized more detailed accident reporting techniques.

They set up a series of definitions of the types of accidents that should be investigated, developed new codes for identifying and classifying the causes of train derailments and devised a process for collecting and analyzing their information.

This collection process contributed to the development of the short form for reporting train accidents now in use by the FRA.

The form requires information concerning the specific location of the accident, the first car derailed, the number of loaded and empty cars, and many other facts of interest to the national track/train dynamics research effort.

The Reporting System group then developed a long form report

to be used in addition to the short form on selected accidents. This long form provides a basis for collecting more detailed information. It is designed to be used in studies of selected incidents or types of incidents in a way that can facilitate future studies of the causes of train derailments.

The Reporting System group made several recommendations for the railroad industry in the Accident Investigations manual. These are:

1. Individual railroads should develop training programs, possibly of a day's duration, in which personnel are trained in the accident investigation procedure.
2. Railroads should consider the creating of accident investigation teams. These teams would have authorities that cross department lines and would be assigned the sole responsibility of accident investigation.
3. Railroads should devise their own standard reporting forms, in addition to those already required, to improve accident reporting and investigation techniques.
4. Accident investigation forms and procedures should be designed with an eye toward computerized processing and analysis of accident data.
5. Railroads should be aware that the benefit of proper investigation procedures will appear in decreased accidents in the future--if the investigations are developed into analyses by which accident prevention practices can be developed.

6. Railroads should be aware that derailments are caused by a combination of factors and investigations should be geared toward discovery of the several factors that led to an individual accident.

It is believed that railroads that follow these recommendations will be in a favorable position to combat the most acute symptom of the dynamics problems facing North American railroads at present--derailments.



From ACCIDENT INVESTIGATIONS

(an excerpt)

FIGURE 23.

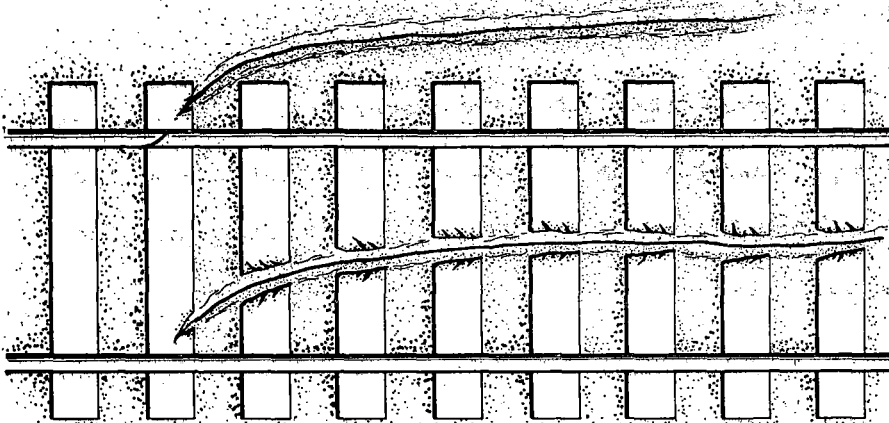

Short Marks Perpendicular to Ball of Rail

Possible Causes: These marks are usually caused by a flange of the wheel as it is forced off the rail. The shortness of the mark is an indication that the forces causing the car to derail were severe enough to suddenly force the wheel over the rail. Within a short distance following the mark, evidence will usually be found indicating the spot where the car wheel(s) contacted the ground. This evidence would include disturbed ballast; marked ties, tie plates, rail anchors, and joint bar; and marks on grade crossings and set-offs.

Factors that may have contributed to derailments of this nature include:

- Sudden load shift
- Improperly loaded car
- Excessive speed around curves

- Harmonic rocking initiated by low joints or crosslevel irregularity
- Slack action induced by a possible Train Handling error
- Broken wheels
- Component failure

It should be noted that these factors can work in combination with one another.

FIGURE 24.

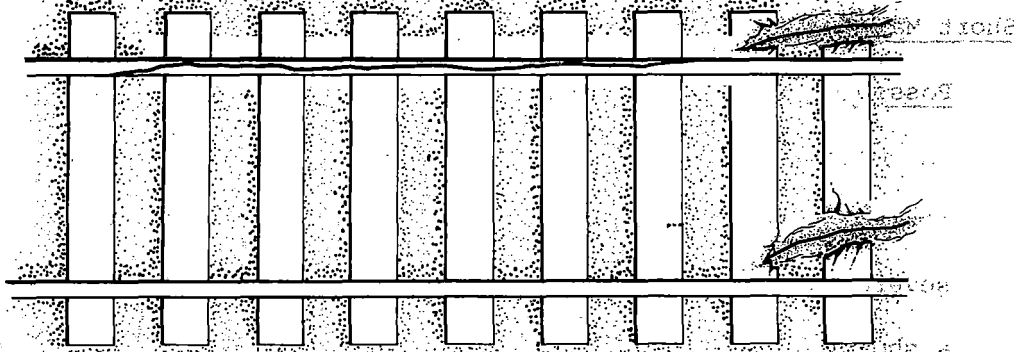

Long Marks on Ball of Rail

Possible Causes: When marks of this nature are found, it denotes that the derailing forces were powerful enough to overcome the normal tracking ability of the car, yet not sufficient to cause a sudden derailment. In this situation, the flange climbs the rail, rides the ball, then usually slips off the field side of the ball. Flange marks up to 40 feet in length are not uncommon in these cases. Where the car contacted the ground will be indicated by the disturbance of ballast

and/or the track base structure.

Such derailments have been caused by:

- Irregularities in cross elevation
- Irregularities in track alignment
- Wide gage
- Improper train handling
- Excessive or free lateral in trucks
- Sharp flanges
- Shifted loads
- Loss of truck spring
- Slack action
- Binding of truck slew action

From ACCIDENT INVESTIGATIONS

(a case study)

Subject: Derailment of No. 49 at Arlington, on February 2, 1973

SYNOPSIS:

No. 49 derailed 18 cars at Arlington, at 1:50 p.m. on February 2, 1973. Damages are estimated at \$81,000. Cause was excessive lateral force on the rear trucks of an empty tri-level which caused the outside rail of a nine degree curve to roll outward, resulting in the derailment of rear wheels of the empty tri-level.

PERTINENT FACTS:

Train No. 49: 76 loads, 44 empties, 20 mph.

Position of Derailed Cars: 25th through 42nd, except 28th and 69th; 14 loads, 4 empties.

Grade/Alignment: Various grades and curvature on approaches to bridge over the Rapid River--see attached sketch. Derailment occurred at MP 18.6.

Track: Good (115# curvemaster rail, rolled in 1968 and laid in 1969, on the high side).

Speed Restrictions (Timetable): MP 15.4 to MP 18.4 - around curves between 3.3 miles east of Lake City and Craig - 30 mph; MP 18.5 to MP 19.0 - over Rapid River Bridge No. 414 and around curves at each end including turnout at end of double track - 20 mph.

DAMAGES:

Damages assessed and/or estimated are as follows:

Equipment	\$41,000
Lading	30,000
Track	5,500
Clearing	4,500
	<hr/>
TOTAL	\$81,000

CAUSE:

At approximately MP 15 the track begins a  $3\frac{1}{2}$  mile descent to the bridge crossing the Rapid River. At MP 18.4, just west of the East & West RR crossing, the track goes from tangent to a compound curve (maximum 10 degrees, 00') with 3 inches of superelevation (equilibrium speed 21-22 mph). The curve ends without a spiral approximately 30 feet west of the Conley joints of the bridge.

No. 49 was made up of five blocks. KTTX902806, an empty tri-level destined for the East & West RR at Centerville, was the head car of the second block. It was behind eleven loads of the first block (24 cars total) and ahead of 14 loads of the second block (35 cars total).

The usual operating practice is for the engineer to apply the brakes on the descending grade, and apply power to keep the train stretched, while slowing from 30 mph on the descending grade to 20 mph on the bridge.

The engineer on the day of this derailment (considered a good engineer by Division officers) stated he was operating the train as he normally operates a train of this or similar consist. About MP 15.5 he made a six pound reduction with the throttle in third notch, about MP 17 he increased

the reduction an additional six pounds, at the signal at MP 18.4 he made an additional five pound reduction (total of 16 pounds). He released the brakes just before moving onto the bridge, which he crossed at 12-13 mph, then made another application with a six pound reduction.

If the brakes were released from the locomotive at one end of the bridge and applied at the other end of the bridge, the lead unit would have travelled the 559 feet at 12 mph in approximately 30 seconds. During this time the brakes would have begun to release in various degrees throughout the train. Thus the brakes would have released more on the head end and probably a little slack ran in. When this happened KTTX902806 was moving through the compound curve between MP 18.4 and MP 18.6. Because of its long coupler shank and the weight of the train behind it, the rear coupler swung through its maximum arc toward the outside of the curve. The high lateral forces exerted on the wheels caused the outer rail to roll and the rear truck dropped between the rails, leaving scrape marks on the gauge side of the ball of the rails. When a flange struck the joint bar, the wheel climbed the rail and the outer wheels were derailed to the outside of the curve. The truck continued off the rail until it struck the turnout of the branch which goes from Arlington to Coldwater. The general derailment then occurred.

The bridgetender, noting the vibration and noise of the derailed car, did not have a radio and, therefore, attempted to contact the Agent at the depot by telephone, but was unable to do so because the Agent was outside giving the train a roll-by inspection. (The bridgetender's shack has been equipped with a radio since the derailment.) When the derailed car came

into the Agent's view, he promptly notified the engineer by radio. Just then the air went into emergency.

The engineer stated, as did the conductor, that he felt no slack. The conductor also stated the brakes never fully released on the rear end when the train went into emergency. The bridgetender stated that the train came to an even stop when the brakes applied in emergency; i.e., there was no slack run-in or run-out. However, as noted in a previous report, impact occurs within the train that is not felt by the crew at either end. In this case there was probably only a slight slack run-in which was enough to force the long shank coupler to swing to the outside of the curve.

#### DISCUSSION:

Three problems exist in this derailment: the make-up of the train, slack action, and the alignment resulting in the ten degree curve.

We believe this derailment would not have occurred if a car with short shank couplers (a plain 40 or 50 foot box car) had been in place of the tri-level equipped with long shank couplers. Had this been the case, the swing of the coupler would have been considerably less and the weight forces of the train would have acted longitudinally in line with the train rather than laterally on the wheels toward the outside of the curve.

However, to block a train so all loads are in front of the empties or to keep all short shank couplers ahead of the long shank couplers would require a train to be run from yard to yard where it would be switched. This would have a disastrous effect on operations. It would require considerable additional switching and a corresponding increase in time and, therefore, must be considered impractical.

The control of slack is a perennial problem. If a train is stretched, there is danger that slack can run-in, either on certain terrain or when brakes are released as occurred in this derailment. If slack is bunched, there is danger that slack run-out will cause coupler failure when the locomotives are accelerated. Thus, it is apparent that slack must be handled properly to prevent these undesirable results.

The problem of the ten degree curve is also present. The alignment is restricted by the bluffs around the river, the location of the East & West RR crossing, and the bridge. Unless the location of the crossing can be moved or changed so it becomes a junction and the East & West RR uses our line as has been discussed, we will continue to operate through this ten degree curve.

Since the derailment the Engineering Department has placed all new ties from the switch at Craig to the bridge, replaced all tie plates with 7 3/4" x 13" double shoulder plates, spiked each plate with two hold down and two anchor spikes plus one hairpin spoke on the high side, and placed double jaw gauge rods every fourth tie. In addition, "O" gauge plates with adjustable braces will be placed when they are received. When this is complete, the track through this area will be very rigid. However, if excessive lateral forces exist, it is possible that a wheel will climb the rail rather than roll it as occurred in this derailment.

RECOMMENDATION:

It is recommended that the consequences of slack run-in be made known



to all engineers. These consequences are particularly important on curves, especially severe ones. It is recommended that our procedures for braking with power applied be monitored frequently so that slack run-in will be minimized. We suggest impact tests similar to those conducted on the Southern Division be conducted on this hill.

## ACCEPTABLE DYNAMIC TRAIN

### PERFORMANCE CRITERIA

As has been mentioned earlier, train handling procedures are designed to improve train performance and reduce the incidence of adverse dynamic effects.



Operating techniques are judged in terms of the results they produce, or by the problems they avoid.

Safety considerations, resultant damages to cargo and components and efficiency evaluations enter into the decision to adopt a certain technique in a given situation.

Train handling techniques used by the engineer create certain actions and forces within the train and track structures. These constitute inputs to the dynamic system that are reflected by dynamic responses of the system.

The same inputs can create a range of outputs depending on the condition of the track, the speed (of the train), the power consist, the lading, and other elements of the system. It is the consequences of a particular train handling technique that has been the focal point of many aspects of the track/train dynamics study.

In the Operating Policies and Train Handling Techniques studies, the techniques selected as best for a particular situation were chosen on the basis of their favorable impact on track/train interactions.

The procedures recommended were the best known to be available. These procedures produce a minimum of adverse dynamic effects, or the lowest magnitude of undesirable forces.

However, to determine how good these best procedures are, it is necessary to determine how bad the procedures can be.

Just as the Bibliography group determined the starting point from which the study would progress, the Dynamic Train Performance Criteria study sought to identify train behavior that handling procedures should attempt to ameliorate.

The criteria are designed to be used in comparative studies that will identify the limits of acceptable train action.

A technique that leads to outputs that exceed these limits is unacceptable. One that produces outputs less than the established limits is considered to be acceptable. And these criteria make possible quantitative comparisons of techniques and, thus, the selection of the one generating the least adverse effects, providing that levels are acceptable.

The group compiled information on nine adverse dynamic conditions that may result from improper train handling procedures or train make-up. These conditions are:

- centerplate separation
- wheel lift
- train separation

- loss and damage to car contents
- fatigue damage to components
- widening of gage
- rail rollover
- track shift
- wheel climb

The Acceptable Dynamic Train Performance Criteria group derived inputs from studies already underway within the AAR and other groups that related to the problems being considered.

Similar problems that fell within the scope of other studies within the Phase One effort were appropriately reassigned.

Centerplate separation, the condition at which vertical centerplate forces diminish to zero or assume a negative (upward) value; and wheel lift, the situation in which vertical wheel/rail forces reach zero or a negative value, can be studied through mathematical models.

The speeds at which these conditions will develop will vary with the make-up and handling procedures of individual trains, as well as with the conditions of track and roadbed.

Train separation was studied in terms of the strength of draft riggings and the forces on them. For example, the Operating Policies group recommended that coupler forces never be allowed to exceed 250,000 pounds.

But one train handling procedure might produce a 260,000 pound force, under certain conditions, and only lead to 225,000 pounds of pressure, under other circumstances. Different handling procedures, under the same conditions, could also yield different coupler forces, some of which might lead to train separation.

Train separation criteria, or rather the criteria to be applied in avoiding train separation, were reported in terms of a probability curve. The curve relates the strength of draft riggings to the probability of separation, under various drawbar forces.

The AAR had already initiated a study of loss and damage to lading when Phase One began. It became a simple matter, then, to bring this study under the general research umbrella of the TTD research program.

Similarly, several segments of the railroad industry were conducting studies of fatigue damage to components. The studies sought to define the dynamic conditions which lead to fatigue damage on several components. The question of fatigue was not of major importance to Phase One, but will become a central issue in Phase Two.

Widening of gage and rail rollover were considerations included in the Special Problems study.

Wheel climb was included in another area of Phase One, that is being developed on a mathematical model to accurately predict the lateral/vertical (L/V) force ratios occurring at the wheel-rail interface.

The last factor, track shift, was also the subject of an ongoing study--this an AAR effort on lateral track stability. The results were incorporated in the Acceptable Dynamic Train Performance Criteria study.

The criteria are being used in conjunction with mathematical models to evaluate the train handling procedures developed by the Operating Policies and Train Handling Techniques groups.

The criteria are basic to the determination of the effectiveness of any train handling method, or in comparison of the advantages of one method versus another.

## INTERACTIONS AND MODELLING STUDIES

The following three sections summarize the Interactions and Modelling Studies undertaken in Phase One. The studies include Mathematical Modelling, Component Performance, and Engineering Test Requirements, and were designed to provide a data base and a computational structure for studying and predicting track/train dynamics problems. A fourth study, the Validation study, was originally a part of this section, but was absorbed into the other three as the investigations progressed.

These three studies were conducted simultaneously, each contributing to the others progress.

## MATHEMATICAL MODELLING

The Track/Train Dynamics Program is concerned with a large number of complex problems--problems for which there exist even larger numbers of possible solutions.

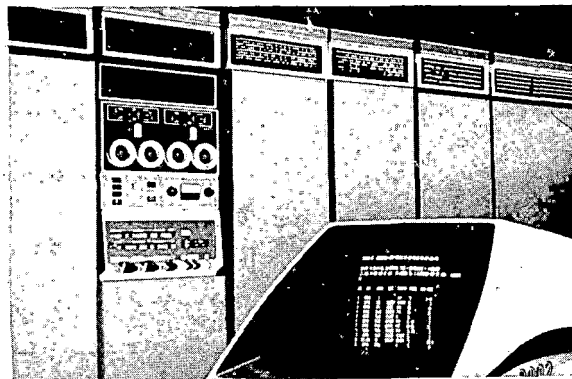

Some of these solutions have been found to exist in the adoption of improved methods of train handling, while others relate to modifications of equipment design.

But these solutions must be tested. Modifications of equipment design require massive expenditures for development, production and implementation. Similarly, revisions of operating procedures require retraining of personnel and, possibly, the introduction of new equipment or instrumentation.

Because of the expense and effort of implementing these solutions, testing before use is desirable.

Testing can show the advantages and disadvantages of any solution and help railroads to make better choices in determining the equipment they will purchase and the operating techniques they will employ.

But testing is a complex task, especially on a full scale basis and in real-world conditions. For a real-world test of equipment and operations, the equipment must be installed on a



revenue train, or engineers must be retrained to perform the new procedures, and the train must be instrumented to determine the effects of the new equipment or techniques.

Before the new equipment is installed or the new procedure utilized, however, the train must make an instrumented, control run, which will provide information about the effects of present methods and equipment.

Then, after the test runs are made, preferably in revenue service, the railroad can determine whether the new equipment or procedure is cost effective in comparison with the old.

But this type of testing contains inherent flaws. One factor is the condition of the revenue equipment. With track that is in constant use, the time changes in geometry can occur between control runs. Rain may soften the roadbed enough to add a variable that was not intended in the testing.

New designs of equipment installed on a working train cannot be tested easily in a worn condition. Its behavior could be more desirable than the response of the worn equipment on a revenue train, but less desirable than the older design when new.

Real-world tests are also expensive. The costs of instrumentation, retraining of personnel, analysis of data and implementation of results can make it seem prohibitively expensive even to try a new system.

But experience indicates that procedures and equipment must be improved in order to facilitate growth and provide for safer, more

effective operations in the future.

On paper, many ideas seem to represent improvements. But the expensive and complex testing process often proves to the contrary. One of the most important projects in the Phase One effort was to find a way to determine, without real-world testing, whether an idea that looks good on paper is really as beneficial as it seems.

This was the job of the Mathematical Modelling group.

A math model can be a very simple equation such as  $F = ma$ .  $F$  is the force,  $m$  is the mass, and  $a$  is acceleration. Of course a simple model such as this does not take into account the effects of frictional forces. To introduce these, a new factor,  $f$  for friction, is used. The model now becomes  $F = ma + f$ , because the force applied must overcome both inertia and friction.

The force required to start up a train is equal to  $ma + f$ , but the real world operation of a train involves hundreds of force interactions within and between individual cars, between wheel and rail, and between locomotives and cars. The force to maintain or change train speed is affected by these interactions which increase and decrease at varying speeds and accelerations, on different track and according to train make-up and handling methods.

The Mathematical Modelling group determined that the train could be treated as a long line of springs, shock absorbers, pivot points and bars and could be analyzed in both detailed and general forms, through computerized models.

By developing models for individual phenomena, it is possible

to study certain facets of track/train dynamics in detail. By developing general models, it becomes possible to study many facets, or groups of systems, simultaneously.

And computer technology makes the task simpler. The storage capacities, the speed of computation and compilation of results and the flexibility provided by proper programming make computerized models a good method of testing equipment and procedures. The models can be used to calculate the effects of an untested practice as long as the new practice does not introduce input variables not taken into consideration by the models. The advantages over real-world testing are threefold. First, the models make possible the calculation of the effects of many parameters, in a short period of time. Second, the models permit studies of situations, such as wheel climb, that are too dangerous for real-world study. And third, a model can provide an indication of the benefits of a system not presently in existence and available for testing.

The Mathematical Modelling group gave first attention to dynamic train action models, but also developed models to evaluate the behavior of equipment and the effects of changes in operating procedures as well as the advantages of different operating procedures.

The Mathematical Modelling group also developed a processor to combine the models within the computer, making many combinations of studies possible.

For the purpose of the following discussion, the models have

been divided into three groups; equipment models, stability models, and combination models.

#### EQUIPMENT MODELS

Locomotive model. The locomotive provides the force output that is an input for all other units in the train, and it is the greatest power source at the engineer's command. General Electric Company was assigned to develop a general dynamic model for the locomotive, describing its effects on train, track and itself. The locomotive model takes into consideration track irregularities and variations such as superelevation, as well as coupler force changes. The output of the locomotive is predicted in terms of locomotive truck platform motions and forces. The complexity of the model may be varied between 0 to 102 degrees of freedom, depending on the detail required by the problem being studied. The model has been completed and is currently being validated.

Vehicle model. This model has been of great importance in the study of harmonic roll by the Special Problems group. The equipment model describes the dynamic behavior of a vehicle under stated track conditions and coupler forces. Included in the vehicle modelling effort are separate models for both rigid and flexible body cars. Both of these models have been completed and validated.

Locomotive truck model. Just as the locomotive model concentrated on the input and output forces acting on the locomotive and train, the locomotive truck study concentrated on the forces into

and out of the locomotive truck. The modelling efforts included two models, with modifications in each to accommodate different numbers of axles per truck. Electro-Motive Division developed a model for a rigid-frame locomotive truck in steady state curving, with modifications to include two, three and four-axle trucks. The company also developed a locomotive truck hunting model which predicts the speeds at which hunting will occur. Both of these models have been completed and validated.

Three-Piece Standard Freight Car model. Clemson University and Arizona State University under an FRA contract, were assigned to develop mathematical equations that could be used to understand truck performance. They utilized laboratory data generated by NASA & ASF to develop portions of their equations which defined the motion relationships between truck components.

Brake model. The Westinghouse Air Brake Company had previously developed a model to determine the effects of braking before the TTD program began. This model was made available to the TTD program and has been incorporated into several of the other models in the Mathematical modelling effort. The WABCO brake model considers friction, velocity, brake pressure, and also makes allowances for air leakage throughout the train. The model is designed to simulate the response of a train of freight cars to the application of the brakes. The weight and position of the car, length of the car, and type of brake, are parameters considered in the program. The program also takes into account information concerning the locomotive consist and the make-up of the train.

Cushioning characteristics model. This model, as the brake model, was designed for use within other model computations. The cushioning characteristics model describes the behavior of cushioning devices between adjacent vehicles. Several subroutines were built to fit into the main model, to facilitate study of products of different manufacturers. The program also includes a routine for incorporating several types of cushioning devices into a single train. The model is in its final stages of development, with some segments already incorporated into other models and completion and validation not yet finished on others.

Curve entry model. The curve entry model is very much like the locomotive and freight car truck models, but this model investigates the behavior of an entire vehicle as it enters a curve. The truck models assumed a steady state of curving. The curve entry model was prepared by EMD. The model is now partially validated.

#### STABILITY MODELS

Lateral/Vertical ratio model. The lateral/vertical (L/V) ratio of wheel to rail forces is a crucial factor in rail rollover and wide gage derailments. A light car could cause a high L/V ratio simply because its vertical force (weight) coefficient is insufficient to balance the lateral force. In other situations, a heavy car which experiences violent hunting can cause this rollover. The lateral/vertical ratio model provides a basis for calculating the relationships between lateral and vertical wheel loads. The effects of these

forces vary according to the time duration of a high L/V ratio, the angle of attack of the wheel on a rail, the wheel and rail profile, and the condition of the wheel and rail. The lateral/vertical ratio is also a factor in wheel climb. Wheel climb occurs when a high L/V ratio is accompanied by a sharp angle of attack of the wheel on a rail--which can lead the wheel flange to climb the rail. The lateral/vertical ratio model also predicts the forces and situations under which this wheel climb will develop. This model has been completed and is in the process of validation.

Quasi-static lateral train stability model. The quasi-static lateral stability model is devised along much the same lines as the lateral/vertical ratio model. This model determines lateral forces generated at the bolster centers of cars negotiating track of any geometry. The lateral/vertical ratio model determined what L/V ratios are undesirable--the quasi-static lateral stability model makes it possible to predict when high lateral forces will occur at the bolster center. Inputs to this model are vehicle geometry, track curvature, lateral clearance and any arbitrary curvature that might occur. The lateral forces at the center of the bolster are calculated from the model inputs. This model has been completed and validated.

Detailed lateral train stability model. The detailed lateral stability model is a third mechanism for predicting lateral forces. The detailed dynamic model determines lateral forces at the wheel/rail contact for any arbitrary train make-up, operating procedure or territory. The detailed model incorporates more input factors than the quasi-static model, and also establishes wheel/rail forces rather

than bolster forces. The detailed lateral train stability model was prepared under an earlier AAR research project and has been completed and partially validated.

Detailed vertical train stability model. Track irregularities and rail profile deviations can lead to vertical bounce problems, especially at high speeds. Severe vertical bounce can lead to coupler buckling between cars. The detailed vertical stability model, designed by Pullman-Standard, predicts whether such vertical buckling will occur during varying instances of severe train action. The model has been completed and validation tests are in their final stages.

Detailed lateral track stability model. This project is designed to study the track parameters and loading conditions that lead to lateral track instability. The detailed lateral track stability model was prepared as an AAR in-house effort and validation of the model is in progress.

#### COMBINATION MODELS

Detailed train action model. The several models discussed above predict either specific forces or force levels, or concern themselves with individual segments of train or track. The detailed train action model is one of three combination models that incorporate several specific models into a more complete picture of the total



train consist and the forces within it. This model was adapted from one developed at the University of Illinois. The U of I model was written for the former New York Central System and required modification and augmentation. With brake and cushioning models incorporated and other improvements made, the finished model can predict the longitudinal forces throughout a 150-car train. Inputs into the model are track and train structures, operating procedures and make-up, and power consist data. Even this detailed model is simplified to some extent, however. The train is represented as a system of masses, springs, and dampers with non-linear responses, with each car given only one or two degrees of freedom. By simplifying many specific parts of the train, the model makes it possible to obtain a very detailed picture of the behavior of the train as a whole. The model has been completed and validation tests are in progress.

Train operations simulator model. This is the most flexible of the mathematical models. The train operations simulator, as its name implies, can be used as a training simulator, and it can serve in several other purposes. The simulator, once referred to as the train performance calculator, simulates the behavior of a train comprised of diesel-electric locomotives and conventional freight cars. The user can simulate the response of a train--to a series of inputs--by introducing throttle and brake handle settings. This allows the engineer to make a test run of a known track, with a known or unknown train, to determine braking problems, longitudinal and L/V forces, and to establish the effects of his train handling procedure.

Using the simulator in this manner, correct and incorrect train handling methods can be evaluated. The T.O.S. model can also be programmed for automatic operation.

The program prepares status reports as the simulated run continues, recording many aspects of the train's condition for later study.

The program requires more computer running time than many other T.O.S. model, but it is very flexible and has many applications.

This model can be used as a training device or as a method of analyzing train make-up and handling procedures to determine hazards before real-world runs are attempted.

It can also be used to analyze the effects of different train consists and brake pipe pressures on necessary signal spacing.

The simulator can be applied to accident investigation. By using as input such information as track, vehicle and train characteristics as well as the train handling procedures prior to the accident, it is possible to determine the types and magnitudes of forces that existed at the time of derailment.

This model has been completed and validated.

Detailed simplified train action model. The detailed simplified model is an attempt to achieve the comprehensive output of the detailed train action model with the computational speed of the T.O.S. model. The model development was undertaken by Purdue University and included three basic efforts. The first effort involved the modelling of a draft gear as a true mass-spring-damper system, permitting the

linearization of the computer model. The second effort was directed toward decreased computer running time through improved model and factor integration techniques. The third entailed the reformulation of the draft gear model itself, to aid in decreasing computer running time.

This model has not been completed.

Pre and post processor. Also known as the Integrated System for Studying Track/Train Dynamics, this program is not a model at all, but rather a computer program that makes it possible to run several related models consecutively. The processor increases the flexibility of using the individual models, by facilitating the flow of information from one model to another. Individual problems that require the use of several models become easier to study with the processor. The pre and post processor has been completed, and its operation is illustrated in Figure 25.

FIGURE 25: POST PROCESSOR

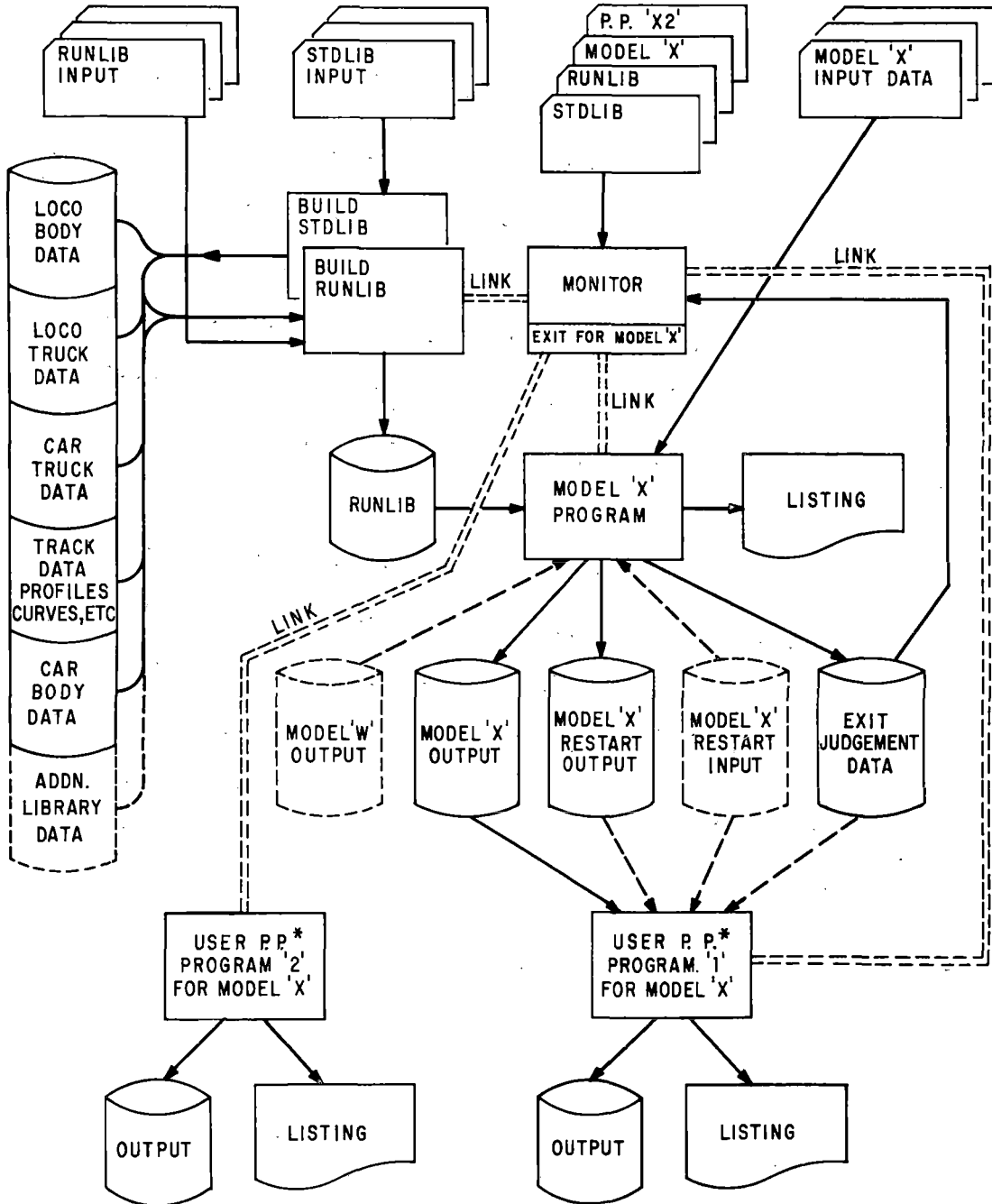

\* POST PROCESSOR

The several models described briefly above will form a core for railroad research that is yet to come. For the first time, it will be possible to study problems of entire train consists, operating procedures and equipment designs with full use of the speed and accuracy of computer technology. The models make it possible to study issues previously based on best estimates and experience and to make parametric studies and quantitative comparisons between alternative practices. The effective use of these models and the application of the results of the model studies can lead to improvements of far-reaching importance in the railroad industry.

In further illustration of modelling, one effort, neither the least nor the most important, serves as an example of the procedures and parameters involved in the development of a mathematical model.

The work described is the study of a detailed simplified train action model carried out by the School of Mechanical Engineering at Purdue University.

Train make-up, operations and geography can vary greatly, as can studies of track/train dynamics problems. These studies can be detailed or basic, depending on the information being sought. Real-world testing requires large capital outlays and tends not to be as flexible as particular studies require. But computer models, requiring less capital investment and offering greater flexibility, provide a basis for simulation and study of these problems.

To provide added flexibility, and to conserve valuable computer core time, the Mathematical Modelling group determined that a few longitudinal train models be developed. These models were to vary according to the quantity and values of inputs and the detail of outputs, as well as by capacity.

The train operations simulator represents individual cars as single degree of freedom systems, coupled by quasi-static draft gear relationships.

The train operations simulator, may be sufficient for predicting actions of a unit train with a small number of low-center-of-gravity-cars. A more detailed model would be used for longer trains of more diverse loads and car types.

The Purdue University research group was requested to work toward increased efficiency of digital computer simulations, using the AAR's simplified train action model, the forerunner of the T.O.S.

The Purdue group tested four integration techniques, feeding

forces into the model and periodically extracting data on the resultant forces.

But the limits of the model revealed themselves in this testing. The force-displacement responses of the draft gear-coupler combination were represented as a linear, quasi-static system.

But the draft gear alone is highly non-linear in its response and when two couplers are joined, the non-linearity increases substantially, especially considering the clearance between couplers.

Force transfers and responses occurred more quickly than the train operations simulator could compensate for, unless extremely small periods were used between measurements of output forces. But these shortened periods increased computer running time substantially and lessened the utility of this approach.

The Purdue group determined that its task would require the development of a new model, rather than improvements in integration techniques.

The Purdue research group then entered into research to determine the dynamic, non-linear relationship between input forces and draft gear response. The dynamic model could then be used in simulation of complete trains.

The first step in the modelling effort was the choice of physical phenomena to be represented. The problem suggested a requirement for a study of the individual components of the coupler system, but it quickly became apparent that the model could not isolate the individual

components of the draft gear, and the equation chosen grouped the response of all components.

The first model equated force with the linear and non-linear responses of the draft gear and the dry friction energy dissipation of the system. By identifying coefficients for these variables and their precise interrelationships, the model was expected to predict the output response to any input force.

Controlled impact tests were conducted with key forces measured to determine the coefficients of the major factors. Extensive impact testing revealed that the model formula predicts peak coupler forces within seven per cent of the actual value measured in tests, a very close approximation for a simplified longitudinal model.

The next step was to incorporate this model of a single draft gear displacement system into an equation of motion for the longitudinal action of an entire train.

The equation takes into account, for each car, the external forces acting on the car (wind, braking, etc.) and the coupler forces on either side of the car.

Then the force transferred from car  $N$  to car  $N + 1$  is equal to the force into car  $N$  (from car  $N - 1$ ) plus or minus the effect of the external forces on car  $N$ .

In this lengthy formula, the linear responses of the coupler system were assumed to be negligible.

As written, the formula was accurate, but took a great deal of



computer time. To reduce computer running time, without significantly affecting accuracy, modal expansion techniques were applied to the equation.

After identifying the normal, linearly independent modes of a linear analog equation to the lengthy non-linear differential equations, the Purdue group began to rewrite the equation in terms of these independent analog forms.

Through the expansion techniques adopted, the group was able to cut computer time considerably. Using this technique, the correlation between predicted and actual displacements has proved thus far to be satisfactory.

## COMPONENT PERFORMANCE

The creation of mathematical models permits the testing on paper of track/train systems, train make-up and handling techniques.

But the development and validation of these computerized models also necessitated real-world testing. The Component Performance study was designed to study dynamic relationships and provide inputs into the modelling efforts, permitting the Mathematical Modelling group to utilize real-world data in the writing of model equations.

Several models involved the prediction of coupler forces in cars and entire trains, necessitating the study by the Component Characteristics group of draft gears and coupler interactions.

A second key area for study was the car/truck system, the determination of the internal interactions of car and truck components.

Several individual studies are included in these major sections, covering either individual components or the interactions between two or three parts of a larger system.

The following is a brief description of the major areas of study included in the Component Performance study:

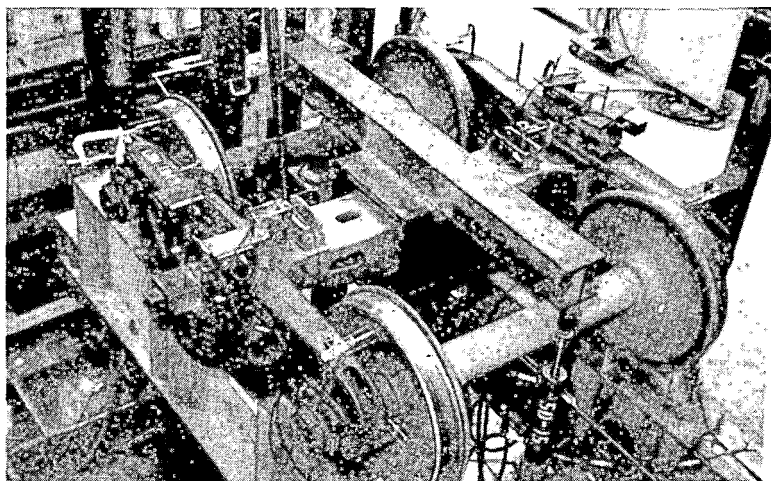

Draft gear characteristics study. The study of longitudinal forces, as noted in the Operating Policies and Reporting System studies, is a key investigation in determining proper train handling techniques. One of the two major sections of the Component Performance study includes the detailed study of the dynamic characteristics of the draft gear.

A contract was awarded to the National Castings Division of Midland-Ross Corporation to study the lateral angling characteristics of draft gear systems. The tests were designed to determine the shift of the moments on which draft gears are centered and about which they rotate in angling situations. The displacement of the coupler shank will alter the moment.

Midland-Ross investigated the minimum and maximum moments of angled couplers and the characteristics of these moments under various loads and the influences of other coupler components.

The Southern Railway system also undertook several studies of specific car and coupler components and cushioning devices.

Southern Railway's study included the use of two instrumented couplers on a car that became part of a test train. The components were tested under conditions that yielded coupler forces up to 300,000 pounds.

Truck, car and wheel characteristics study. This study, undertaken by several organizations, was designed to develop test data describing truck and car interactions and truck component interactions.

This information was used in the development of analytical models and eventually to be used in parametric studies of truck curving, truck hunting, truck responses to track irregularities and wheel/rail interactions.

Many of the parameters studied had not been studied in detail before and it was determined that the complexity of the interactions would require a highly detailed study. Because the majority of testing experience in linear and non-linear system of great complexity had been accomplished through the aero-space industry, the Component Performance group sought out the expertise available through the National Aeronautics and Space Administration with funding from FRA.

Through NASA, a contract was awarded to Martin-Marietta Corporation in Denver to perform static tests to determine preliminary values and ranges of motions to be studied; establish estimates of the force and motion magnitudes that would likely be encountered in dynamic tests; develop analytical models; determine car/truck force transfer functions; and assist in planning detailed field tests to verify their laboratory results.

Another effort was undertaken by American Steel Foundries, at their Test Department in Granite City, Illinois. The ASF contribution to the program was a seven part study designed to determine the damping characteristics of several car stability control devices, and to determine several characteristics of a ride control truck.

In addition, Brenco, Incorporated, of Petersburg, Virginia, accepted the task of performing an analytical and experimental evaluation of the truck's primary suspension system.

National Castings Division of Midland-Ross Corporation was contracted to determine the lateral force characteristics of the drawgear system during coupler angling under various buff and pull train loads. Components involved in the drawgear include coupler, yoke, draft gear and related parts. Characteristics of a coupling system with a simple spherical shank bearing surface under buffing loads were estimated without test.

Specific tests were conducted on both the Standard AAR rigid shank E coupler connection and on the Standard AAR F coupler with alignment shoulder connection. Conventional 24-5/8" pocket draft gears were varied throughout test and include common high capacity (AAR Specification M-901E) friction, rubber friction and rubber types, as well as three common older (AAR Specification M-901) friction gears. Results proved to be basically independent of draft gear type.

The study of components and their interactions in the several sub-systems of track/train dynamics yielded necessary data for further modelling and component study efforts.

The following is a more detailed description of one of the specific studies conducted as part of the Component Performance study. Again, the example is not the most important or difficult of the Component Performance studies, but serves to illustrate the efforts involved in this activity.

Above certain operating speeds, trucks susceptible to hunting will experience violent actions. Their wheels will oscillate, impact first one and then the other rail, restrained only by the wheel flanges. Primary and secondary suspension systems do not always provide the damping needed to forestall or mitigate violent hunting.

The Primary Suspension System study was designed to provide input data for later modelling attempts, in an effort to determine the causes of this hunting and the reasons why primary suspension systems are now unable to eliminate the problem.

Brenco, Inc., of Petersburg, Virginia undertook an assignment to study the truck's journal bearings. The primary suspension system includes the truck's journal bearing, bearing adapter and the associated side frame region. The primary suspension works with the wheel set, absorbing the first effects of wheel/rail interactions.

The secondary system consists of spring coil groups in the truck assembly make-up.

Principal investigator G. J. Moyar and other members of the

study group used both instrumented load and motion imposition tests and a computer analysis.

Although the instrumented testing set-ups did not fully duplicate in-service conditions, the method was sufficient to focus on the effect of bearing stiffness and clearances between the journal assembly and the side frame. Load test situations provided both lateral and vertical loads which acted directly on the bearings.

Bearing stiffness and free clearance measurements were obtained in several types of truck motion--lateral, forward and reverse, yaw and vertical. Data obtained were also related to component age and wear.

Additional distortion data were obtained under controlled loads to study in-service forces that might cause such distortion in pertinent parts of the primary suspension system.

Brenco investigators concluded that linear elastic models of the primary suspension system might be satisfactory for representation of primary suspension stiffness under moderate to heavy loads. The group advised, however, that proper account must be taken of free clearances and threshold friction resistance.

The group recognized that a load interaction effect exists, noting that the vertical journal load has a measurable effect on lateral frictional and elastic resistance. The Brenco group advised, however, that load interaction characteristics be ignored in the initial truck models.

Reliable prediction of bearing/adaptor deflections seem

possible through the use of elastic, finite element computer models. The group based this conclusion on a good correlation between theoretical and experimental findings in simple lateral loading tests. Another application of such models was made to illustrate the detrimental effect of adapter wear on internal bearing reactions.

The group's findings were transmitted to the modelling group for use in its study of the truck sub-system.



## ENGINEERING TEST REQUIREMENTS

The study of a complex problem requires that all factors be considered and accounted for in the conclusions that are reached through research.

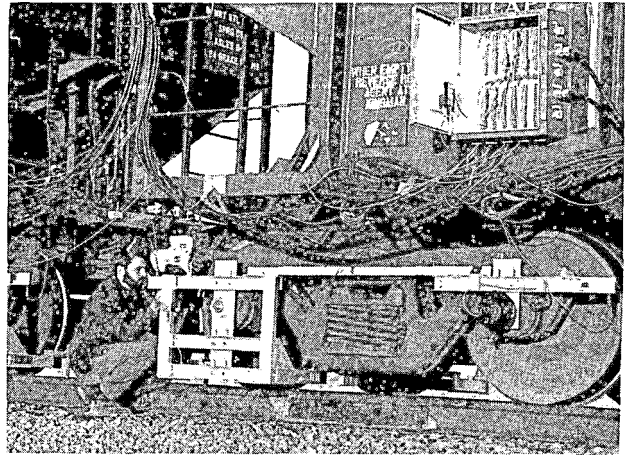

Such is the case in the track/train dynamics research program, where the development or mathematical representations of track, train and component behavior required the development of models for several forces and subsystems of the whole.

But validation of these models--the process in which the mathematical bugs are worked out of the equations--requires a detailed study of all the factors considered in the models by comparing behavior predicted by the models and with behavior measured in tests.

In order to make certain that the models are properly validated, it is necessary to ensure that the validation process is as complete and accurate a reflection of the real world as is technologically possible.

To develop equipment and tests by which the models would be tested was the function of the Engineering Test Requirements group.

The group undertook three basic efforts. First, the group had to design new forms of instrumentation to measure forces

displacement, velocities, accelerations, etc. never before required for an in-depth study on train behavior. Second, the group was expected to modify and improve the equipment to adapt it to specific problems encountered in the tests. Third, the installation of the instrumentation and the conduct of revenue train tests. The results of the tests would become part of the validation effort for the mathematical models.

Early in the planning stages of the math modelling effort, the Engineering Test group was already undertaking an effort to find methods and equipment to validate the models.

The group contacted dozens of suppliers, railroads and experts in the industry as they formulated the testing and instrumentation requirements needed to make the effort a success.

In the early spring of 1973, shakedown tests were made. The first tests were designed to determine many of the dynamic conditions that would be experienced in the train action studies and to determine the advantages and limitations of the instrumentation packages.

The tests proved beneficial and the group focused its attention on two major testing efforts: the unit train test and the high speed train test.

It was determined that the unit train test, also referred to as the SP steel coil train test, would be conducted on a Southern Pacific revenue run in the spring of 1973.

The run of the train, filled with steel coils in identical cars, was set for three days over the 1,400 mile route from Fontana, California to Tucumcari, New Mexico.

Lateral and vertical coupler forces, coupler angles, relative speeds and positions of adjacent cars and draft gears, and various other train characteristics were measured by the instrument packages on the unit train.

Acceleration, speed, brake pressure, and other factors, were also included for study.

After a brief setback when it was discovered that test equipment on all six instrumented cars had broken, the first test began, two weeks late.

But further setbacks awaited the group. It was learned that factors unknown at the time of the test had contributed to invalidate the entire study, forcing a redesign of many test components and a rescheduling of a new test.

The unit train was ready for a second test in the late fall, after several more shakedown runs of test equipment. The test run from Fontana to Tucumcari was successfully completed.

The second major area of testing activity was encompassed in the 1973 testing efforts at the Transportation Test Center in Pueblo, Colorado and on the Santa Fe Railroad. Because some of the equipment required for the high speed tests was being used in the unit train tests, the high speed tests were also delayed.

One of the major results of these tests was the validation of the G. E. locomotive model.

As these two efforts neared completion, several other testing efforts were begun.

The L/V and lateral train stability tests. This was one of several efforts involving development of tests and measurements to determine the accuracy and weaknesses of mathematical models. Test requirements were established in 1973 and equipment shakedown runs were undertaken on the Southern Railway. The tests were later conducted at the Transportation Test Center in Pueblo, on the track/train dynamics loop.

The factors studied to establish the derailment tendencies of different types of freight cars included:

- the effects of longitudinal forces between 50,000 and 300,000 pounds
- the effects of random forces superimposed on steady-state forces
- the effects of hunting and the speeds at which hunting occurs

The method employed to prevent derailments in these high-force level tests interfered with the truck hunting study but did not introduce a major setback.

Tests to validate the L/V model included monitoring of derailment indicators in order that dangerous force ranges were not exceeded.

Similarly, the other models were validated based on testing techniques developed and refined in the unit-train and high-speed tests.

Because the testing of models required collection of voluminous information and close cooperation was maintained between modelling and testing groups, it became a simple matter to absorb validation efforts into the modelling effort.

The three efforts just discussed--Component Performance study, Mathematical Modelling effort, and Engineering Test Requirements study--form a scientific base of test data, test procedures, and analytical techniques for studying the dynamics of track/train systems--systems as complex as those studied by NASA in its space exploration efforts.

The value of this effort will be measured in the long term improvements and refinements made possible by application of findings of these studies.

## TRAIN HANDLING TECHNIQUES

One of the key goals of the National Research Program on Track/Train Dynamics has been the development of methods through which present equipment could be used most efficiently and safely. The



need to move equipment quickly, with a minimum of breakdown, risk and wear, has been the driving force behind the research effort.

The Operating Policies study group achieved that goal, in part, through its development of the Interim Guidelines on train handling and make-up techniques.

These guidelines were the result of surveys and study of the best operating methods employed at railroads throughout the country.

But these guidelines, extracted from hundreds of present operating techniques, are based almost entirely on trial and error approaches. The risk of experimentation is great, and a railroad might adopt a method based on its experience with several operating techniques, but other, better methods could have existed beyond the range of experience of the railroad.

It was also possible that the optimum train handling methods had not been arrived at through the trial and error experi-

ence of any of the railroads and that each interim guideline was the reflection of best known methods from a necessarily limited experience.

Continued trial and error studies would be extremely time-consuming, costly, and possibly inconclusive--in the real world.

But the development of accurate mathematical models of train forces and actions has made it possible to study the best known train handling techniques and to determine if the best known methods are in fact the most desirable from the standpoint of train action.

The interim guidelines, detailed though they are, must be considered to be relatively untested in light of the complexity of force combinations discovered in the Mathematical Modelling, Component Performance and Engineering Test Requirements studies.

But through the use of the mathematical models, most notably the train operations simulator, the quantitative differences between operating techniques can be determined.

The Train Handling Techniques group was assigned to utilize the computer models to validate, and modify or reject individual items in the interim guidelines by determining mathematically which train handling techniques are the most desirable in any given situation.

The variations in terrain, consist, coupler state, speed, acceleration, braking, power and other factors that could be used as inputs in testing train handling techniques are literally endless.

In fact, a railroad could feed test data into its models to find the best operating practice for each run--but even with the speed of modern computers, the number of runs necessary might require more time than the actual train run.

For this reason, the Train Handling Techniques group chose representative train consists and handling techniques for study and established a basis for quantitative representation to establish the best techniques.

The result of the Train Handling Techniques efforts was a 295 page matrix of train runs, including a variety of input factors, other techniques with which the suggested technique should be compared, and references to the areas of the Interim Guidelines in which the technique or operation is discussed.

The result of this activity will be to find the most desirable train handling techniques and to have confidence that the techniques chosen for use are, in fact, the best available.

The following pages will provide an example of the testing procedure involved in the use of the train handling matrix.



The train handling matrix includes a few selected examples, believed to be representative of real world conditions regarding train make-up, operations, etc. These selections do not represent all possible combinations, but they are considered sufficiently representative to permit the comparison of operating procedures so that the best practices can be determined.

Train lengths. Three representative train lengths are included in the matrix. Obviously, this is only a fraction of the number of possible lengths, but the examples are considered to be representative of the basic classes of train lengths.

1. The 86-car train is representative of a train operating over heavy grade territory under conventional power.  
(Conventional power is the use of power at the head end of the train with no helper units or radio controlled equipment locomotives.)
2. The 115-car train is representative of a train operating in light grades under conventional power or over heavy grades with RCE-1 equipment or helper units.
3. The 150-car train is representative of a long train operated under conventional power in flat territory, or increased power on light grades. This train would also require RCE-1 power for heavy grades.

Train consists. Earlier studies have indicated train make-up

is an important factor in the generation of in-train forces.

1. Weight--

--Two-thirds of the cars will be loaded in any of the train lengths mentioned.

--All locomotive and car weights are applied to the rails.

--The average loaded car weighs 80 tons; the average empty car weighs 27 tons.

--In unit trains, all cars are loaded and weigh 131 tons.

2. Weight distribution--

--uniform, with loaded and empty cars distributed throughout train.

--tail end, with loaded cars at the tail end of the train.

--head end, with loaded cars at the head end of the train.

3. Basic consist--

--The basic train consist is a combination of 43 different cars. Each of the three train lengths studied is built from sections of this basic consist.

Power consist. As important as the make-up of the resisting force structure (the train) is the make-up of the motive force structure.

Other assumptions are made in the matrix format, yielding 31 combinations of train lengths, power and consist. These 31 representative examples provide a description of the trains presently in operation.

With the large number of combinations of other factors involved, it was not feasible to run computer simulations of all 31 combinations on all terrains with all operating procedures.

Because of this situation, a technique was borrowed from other sciences as described below.

Assume an engineer wants to start a train on an incline. By applying the same starting technique to three train lengths in the matrix, the effect of train length for incline-starting can be established. Then a slightly different starting procedure is used for one train length. If the second procedure is preferable for one length, it is assumed to be preferable for the other two.

Thus, by altering one factor at a time and keeping the rest constant, it is possible to determine trends and tendencies without running all possible combinations.

If any runs show disproportionate results between any two techniques, more detailed investigation is always possible.

The matrix lists several test runs under varying conditions, make-ups and operating procedures. As an example of the procedure and factors involved in these tests, consider Run 8a, which appears in Figure 26 as it is shown in the matrix.

FIGURE 26: TRAIN HANDLING MATRIX TABLE

Run No.	Terrain	Operating Requirement	Initial State of Slack	Operating Philosophy	Consists	Train Handling Techniques			Additional Train Handling Methods Used With Technique	Run and Technique Comparison	Remarks
						Brief Description of Train Handling Technique	Track/Train Dynamics Manual Reference	Temporary Matrix Table Reference			
R8a	Level	Stopping (from a speed less than or equal to 15 mph.)	Bunched	Stop with slack bunched, using automatic brake	115UC2 115HC2 115TC2 115UR2	Gradually reduce the throttle to idle, allowing the train to bunch against the lead locomotives; using the lead locomotive consist independent brake to aid in accomplishing this, if necessary. Complete the stop by making a minimum reduction with the automatic brake and having the lead locomotive brakes applied when the train stops. Use sand for the last eight car lengths.	Outline 2.L.2.2.A.1a Page 2-21 G.N. 2-20	1,2,3,4, 5,6,7,8,9	M1, M2, M4, M21, M31	Compare 115UC3, 115HC3, 115TC3 and 115UR3 with their counterparts in R7a to evaluate what effects different initial states of slack (stretched or bunched) have on in-train forces for this type of handling technique.	1. Initial speed of 15 mph.  2. When making a run with an RCE-1 consist, have remote units in MU.

Run 8a appears as R8a in the matrix. The R signifies that the designation is a run number, the 8 denotes the eighth type of run (the run number changes with a change in terrain, operating requirement and philosophy, coupler state and operating technique). The "a" signifies the first attempt at this run.

The terrain is assumed to be level for Run 8a. The engineer must initiate some action while running at a speed of 15 mph or has to stop his train. His operating philosophy is to utilize the automatic brake to stop with his couplers in a buff state. In this run, his couplers are in buff at the beginning of the test.

The process is lengthy and comparison of techniques requires a great deal of skill, but the matrix tests allow railroads to determine scientifically with computer speed the desirability of different techniques.

The use of the matrix to validate and improve train handling methods can lead to improved engineer training, lessened wear of track and equipment, reduced accidents, and improved speed and efficiency of operation.

In addition, the Train Handling Techniques group was also requested to create a method for continued study and validation of train handling methods. Tables of runs for various coupled pairs of cars, and other efforts, also have been completed by the group.

## SPECIAL PROBLEMS

Much of the national research program effort has been designed toward the elimination or lessening of adverse dynamic conditions generally, throughout the train and track systems.

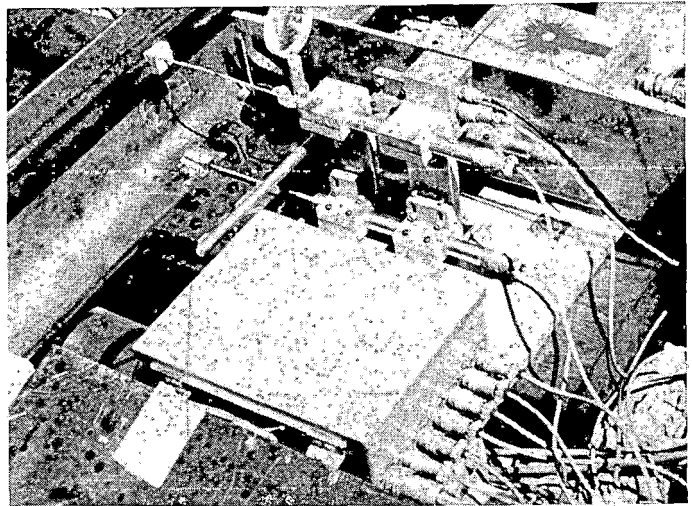

Wear, damage and loss of all types can be eliminated through the general lowering of lateral and longitudinal force levels and much of the operations and modelling efforts thus far have had as a major thrust the overall mitigation of adverse forces.

But two problems caused by dynamic interaction of train and track have been of such prominence as to require separate study.

In the planning of the International Research Program on Track/Train Dynamics, the Southern Pacific sent questionnaires to selected railroads to determine the problems creating the greatest concern. It was learned that harmonic roll and gage widening were of significant concern to the industry.

Wide gage is a track irregularity in which the distance between parallel rails increases, as shown in Figure 27. When the rail gage increases, the wheels ride lower on the rail, causing wheel damage,

FIGURE 27: WIDE GAGE

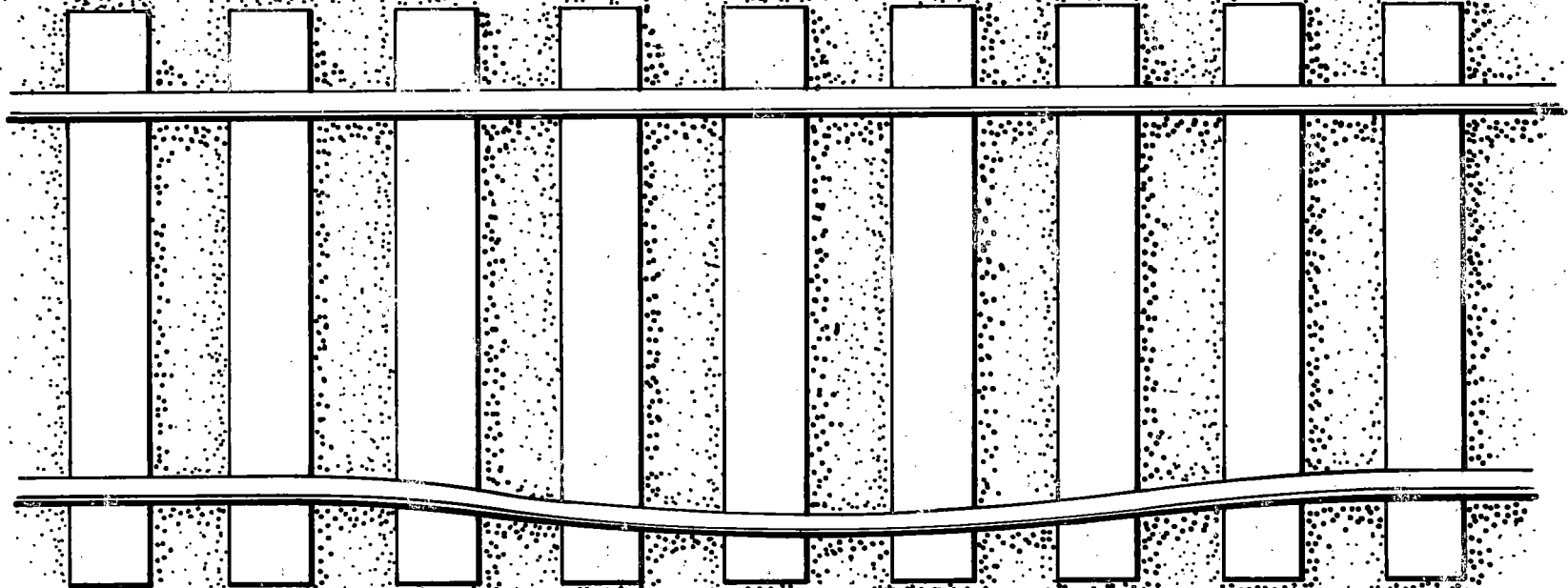

extreme rail wear, and possible derailment.

Harmonic roll is another situation that can lead to derailment. As shown in Figure 28, it is the periodic shifting of the car weight from one rail to the other. This shifting leads the car body to rotate about its longitudinal axis, sometimes resulting in wheel lift and derailment.

The problems posed by harmonic roll and wide gage are both serious and dangerous, and the studies of these phenomena borrowed from the progress of the other study groups within the Phase One effort, as well as from individual tests.

Many of the mathematical models were utilized in these studies as they were completed, as were operating techniques which led to decreased incidence of harmonic roll and wide gage.

A more detailed description of each of these studies follows.

HARMONIC ROLL. As demands on the railroad industry has increased in recent years, several innovations have been introduced in the form of new equipment. One of these innovations has been the heavy, high-volume, freight car that is more prone to harmonic roll.

Harmonic roll, also called rock and roll, results during the operation of certain freight cars over jointed track, at speeds between 15 and 25 miles per hour.

The Special Problems group was assigned to develop guidelines for minimizing harmonic roll, to create models and study component



FIGURE 28: HARMONIC ROLL

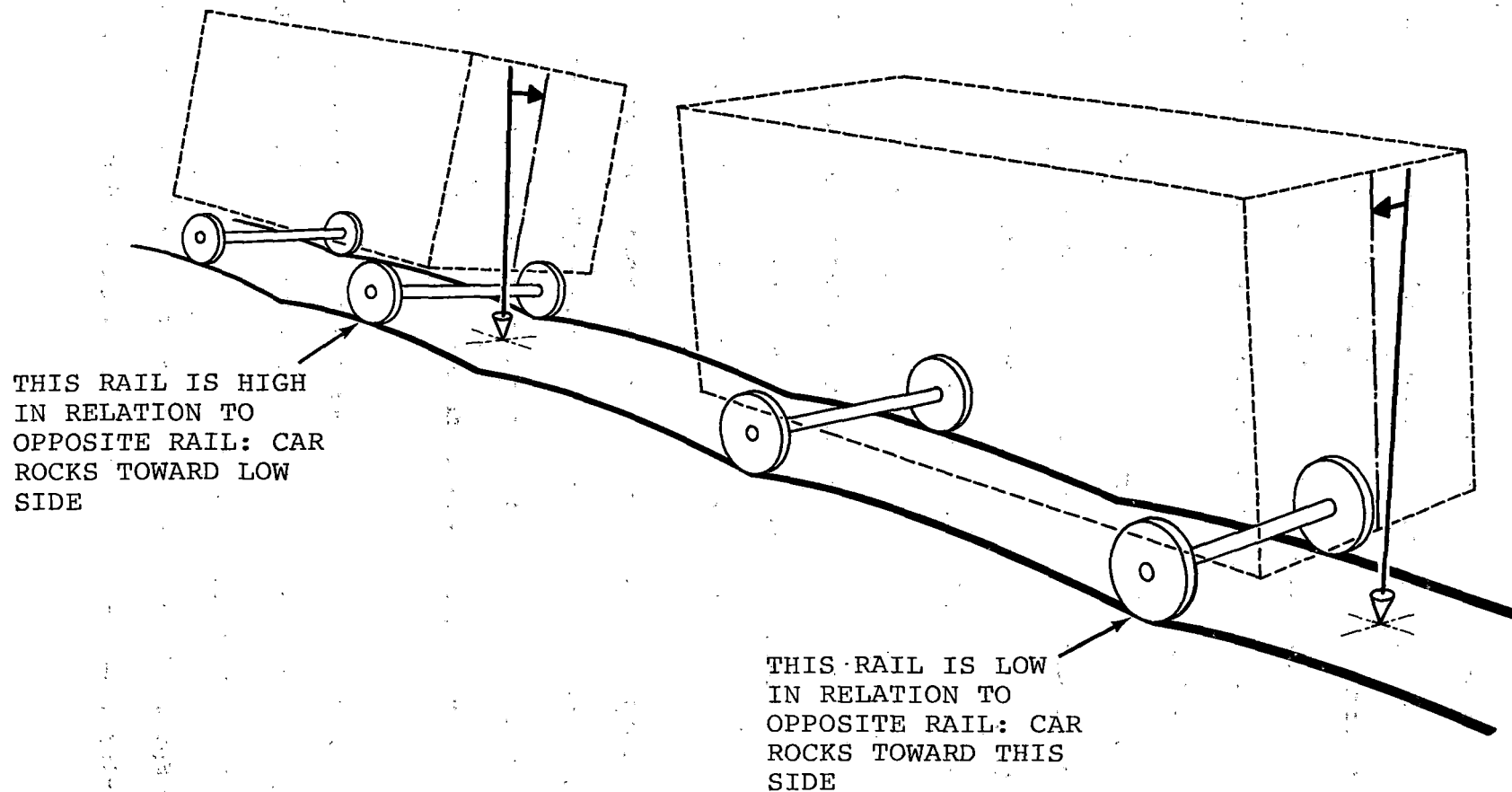

characteristics related to the phenomenon, and to attempt to determine the means by which the problem could be eliminated.

The group has developed material discussing the causes, solutions and other references to harmonic roll. Three volumes of information have been completed thus far.

The first volume states the causes and recommended solutions for harmonic roll. Its symptoms are listed in order that railroad employees can more easily identify rock and roll and take action to remedy this adverse dynamic occurrence.

#### THE ROCK AND ROLL DIAGNOSIS CHECKLIST

##### A. Derailments

1. First car off was heavy, high-center-of-gravity car.
2. Derailment occurred on curve.
3. Track prior to point of derailment had several low joints or soft spots.
4. Train was travelling between 15 and 25 miles per hour.
5. First car derailed to outside of curve.

##### B. Equipment

1. Broken body center plates.
2. Evidence of springs going solid.
3. Broken springs.
4. Side bearing damage.
5. Excessive side bearing clearance.
6. Shifted lading in lateral direction.

### C. Track

1. Low joints.
2. Difficulty with maintenance of track surface.
3. Broken track components.
4. Corrugated rail in curves.

Of course, one broken spring does not indicate that severe rock and roll exists, but combinations of several of the above symptoms point to a need to consider the possibility of rock and roll.

The problem is particularly prevalent on jointed track, because a sequence of low joints may develop. In areas with several, staggered, low joints, the problem can be serious.

The extent of low joint deviation from cross level will have an effect on the magnitude of rocking induced in the cars. Cross level deviations under  $5/8$  of an inch will induce rocking, but will not cause wheel lift. Between  $5/8$  and  $3/4$  inch, wheel lift becomes likely. And with deviations over  $3/4$  inch, derailment is probable.

Such slight deviations from cross level can have such great impact because the slight deviations are added to several other factors, each of which plays a small, but critical part in harmonic roll.

Superelevation, the banking of track on curves, plays such a

role. Trains coming into curves will tend to lean toward the inside of the curve, the low side, unless the train is traveling at a high enough speed for centrifugal force to properly push it against the outside rail. The speed at which the centrifugal force outward is equal to the gravitational force inward is known as the balance speed.

As shown in Figure 29, the effect of unbalanced superelevation is to increase the wheel load on the inside rail and decrease it on the outside, possibly leading to wheel lift.

FIGURE 29: THE EFFECTS OF UNBALANCED SUPERELEVATION  
IN THE CREATION OF WHEEL LIFT

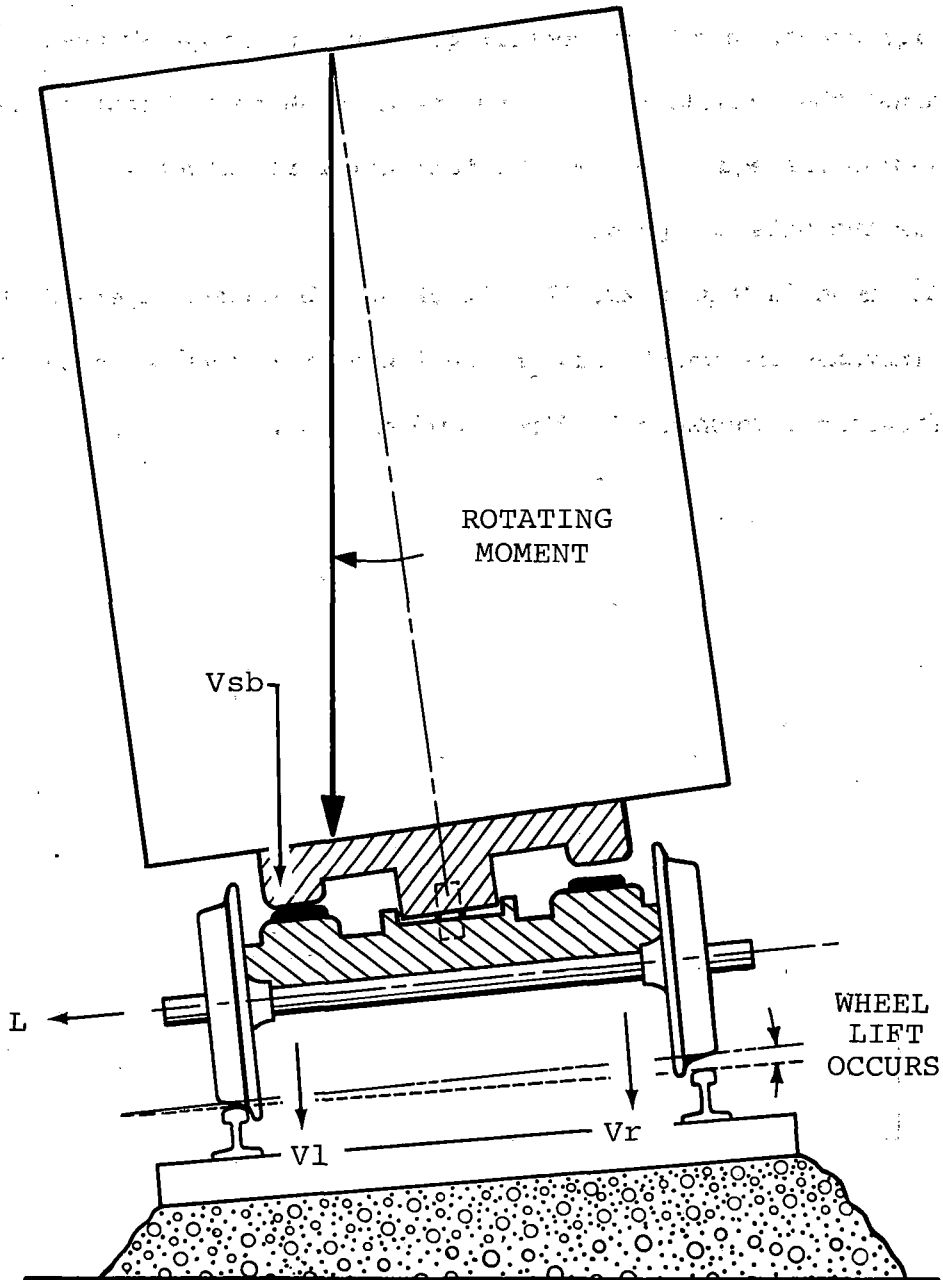

$L$  = Resulting lateral force from rolling car body applied to truck

$V_l$  = Vertical force on journal from weight of car and vertical force due to rolling motion

$V_{sb}$  = Vertical force acting on side bearing due to rolling car body

$V_r$  = Vertical force reduced by car body rolling toward opposite side

The problem is aggravated by the fact that many railroads set their superelevation for the balance speed of faster, lighter passenger cars. This cross level difference is too great for the heavy, lower speed, freight trains. Many railroads have begun decreasing the superelevation on curves to accommodate increased freight traffic.

Another track structure problem in harmonic roll is the staggering of track joints. On track with joints staggered at  $\frac{1}{2}$  rail lengths from one side to the other, low joints become a crucial factor.

The problem is aggravated by the tendency of high-center-of-gravity cars to have truck spacing about equal to the length of a rail. Rail lengths of 39 feet combine with cars with 37 to 44 foot truck spacing, creating harmonic roll.

When the distance between trucks is about the same as the distance between joints, both front and rear wheels, on the same side of the truck, will be in low joints at the same time. When the left wheels of the front truck are rolling over a low joint, the left wheels of the rear truck are also on a low joint. On rail with joints staggered at half rail lengths, the right wheel sets will experience the same situation  $\frac{1}{2}$  rail length further down the line.

As shown in Figure 30, harmonic roll is intensified on track with rail length approximately equal to truck spacing, and mitigated when the trucks and joints do not match.

FIGURE 30: TRUCK SPACING AND RAIL JOINT SPACING  
IN HARMONIC ROLL SITUATIONS

150

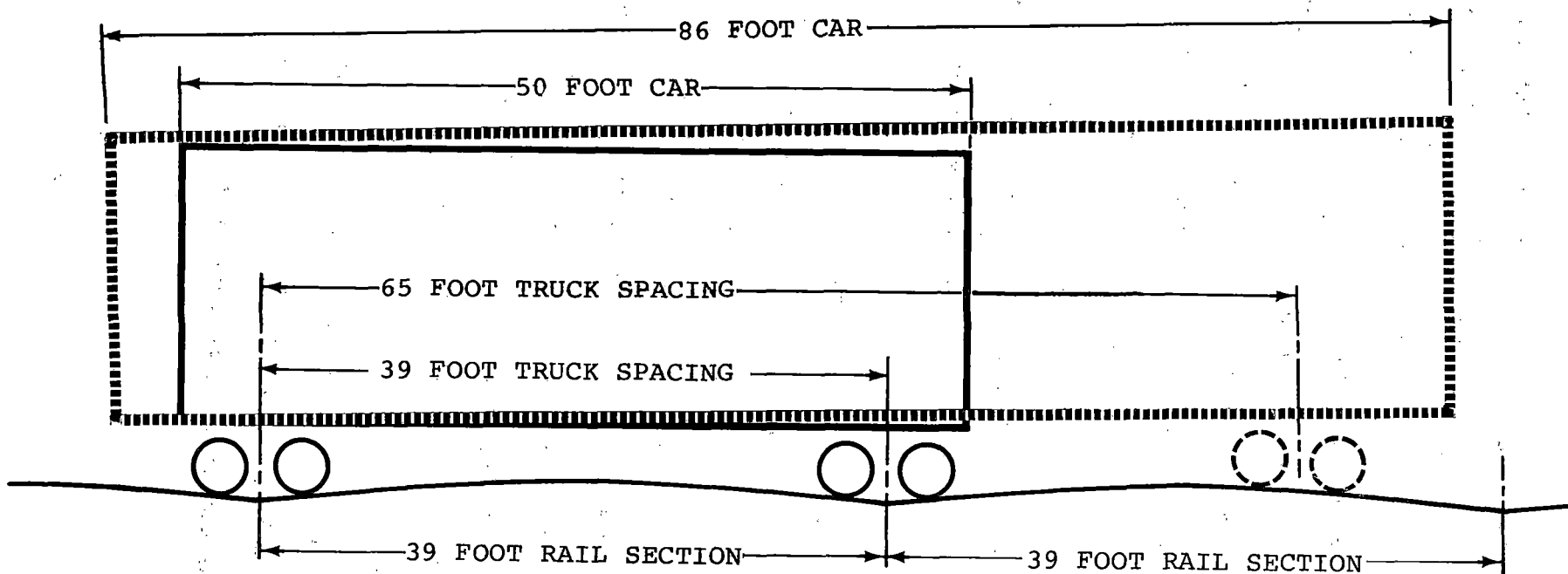

Laying welded rail will help eliminate rock and roll problems. But care must be taken to space the welds away from the areas of the old joints. Rail profile studies indicate the roadbed will retain the memory of the low joints and welds at the joint locations can also develop into low points.

Another solution, one not as expensive as laying welded rail, is to field weld jointed rail. Again it is necessary to move the rail so that welds do not appear at the location of previous joints. A third method is to restagger the rail joints at  $\frac{1}{4}$  rail lengths. The  $\frac{1}{4}$  rail length deviation vastly reduces harmonic roll tendencies, because the new staggering changes the time cycle. This change lessens the cumulative effect of the low joints and lateral motion.

Another possible solution to the harmonic roll problem would be to use longer cars, cars with truck spacing different from rail joint spacing. It has been learned that 86-foot, high-center-of-gravity cars do not experience rock and roll derailments, because their 65-foot track spacing does not permit the harmonic effects to accumulate on jointed track.

If truck spacing and rail length must be similar, rock and roll can be mitigated by lowering the center of gravity of a car. Cars with high centers of gravity experience more severe rock and roll than low-center-of-gravity cars. As severe harmonic roll develops at the wheel/rail interface, the damping



systems of truck and car are not able to mitigate all forces and some lateral rotation is begun in the car. Cars with high-centers-of-gravity have a longer effort arm (from center of gravity to floor of car) to pry against the fulcrum created when car and side bearing come in direct contact.

This effort arm can be decreased by lowering the center of gravity--either through packing techniques or through a reduction in the car load.

As harmonic roll increases the lateral rotation of the car body, the car pulls at the wheel sets. If rock and roll becomes severe enough, the car body will pull the wheel set off a rail, causing derailment.

To mitigate these problems, the Special Problems group suggests that improved damping systems and more flexible car body designs be developed to absorb harmonic roll forces, to design lower-center-of-gravity cars, and load these cars so that the center of gravity remains low, and to operate trains outside the critical speed range of 15 to 25 miles per hour.

Volumes II and III of the Harmonic Roll study concern themselves with specific equipment designs. Borrowing from the Component Performance studies and Mathematical Modelling efforts, the Special Problems group developed a two-volume reference on damping systems, car and truck models and other sub-systems in the train consist, as a means of describing the relative ability of these systems to aid

in resisting rock and roll. Volume II describes truck component characteristics and Volume III details car design parameters.

Soon to be completed is Volume IV, concerned with work done by ACF Industries and Pullman Standard in generating vehicle characteristics.

Through the conclusions reached in the harmonic roll study and the data accumulated concerning equipment, railroads can direct their future maintenance and equipment design specifications in such a way that harmonic roll, and its subsequent derailments, can be eliminated.

WIDE GAGE. The second special area investigated during Phase One was the wide gage and sudden rail rollover phenomenon,

Wide gage is the result of a track's inability to maintain the original distance between rails. It is the result of severe lateral forces on the rail. These forces can also result in the second track phenomenon--rail rollover.

Wide gage can be detected by the cutting or crushing of ties at the field side of tie plates, permanent lateral deformation of spikes, and tie damage at the spike holes.

Wide gage is a chronic occurrence. The continual imposition of high lateral forces on the rail will slowly push the rail outward. But rail rollover is an acute phenomenon. Rollover is the result of the sudden failure of a rail section to maintain proper vertical orientation under lateral strain.

Investigations into the wide gage and rail rollover phenomena have pointed, predictably, to heavy cars, sharp curves and track ballast that does not give under pressure.

More specifically, the problem was traced to heavier, 6-axle locomotives, unit trains of 100-ton cars, curves greater than 4 degrees and frozen track ballast in winter.

In some cases, wide gage has also developed on tangent, high-speed track.

Battelle Laboratories of Columbus, Ohio, received a contract to identify the factors that cause the wide gage and rail rollover.

Battelle conducted instrumented train tests on a high-speed section of tangent, Union Pacific track in Idaho. The tests were conducted both in winter and in spring, to study further the effect of frozen ballast on rail rollover.

From the data collected in its studies, Battelle concluded that wide gage is caused primarily by secondary truck hunting--a situation in which high lateral forces will cause the wheels of a truck to slam from one rail to the other. In such hunting, the wheels are at an angle to the track and no longer parallel. This angle is known as the angle of attack, as shown in Figure 31.

FIGURE 31: ANGLE OF ATTACK

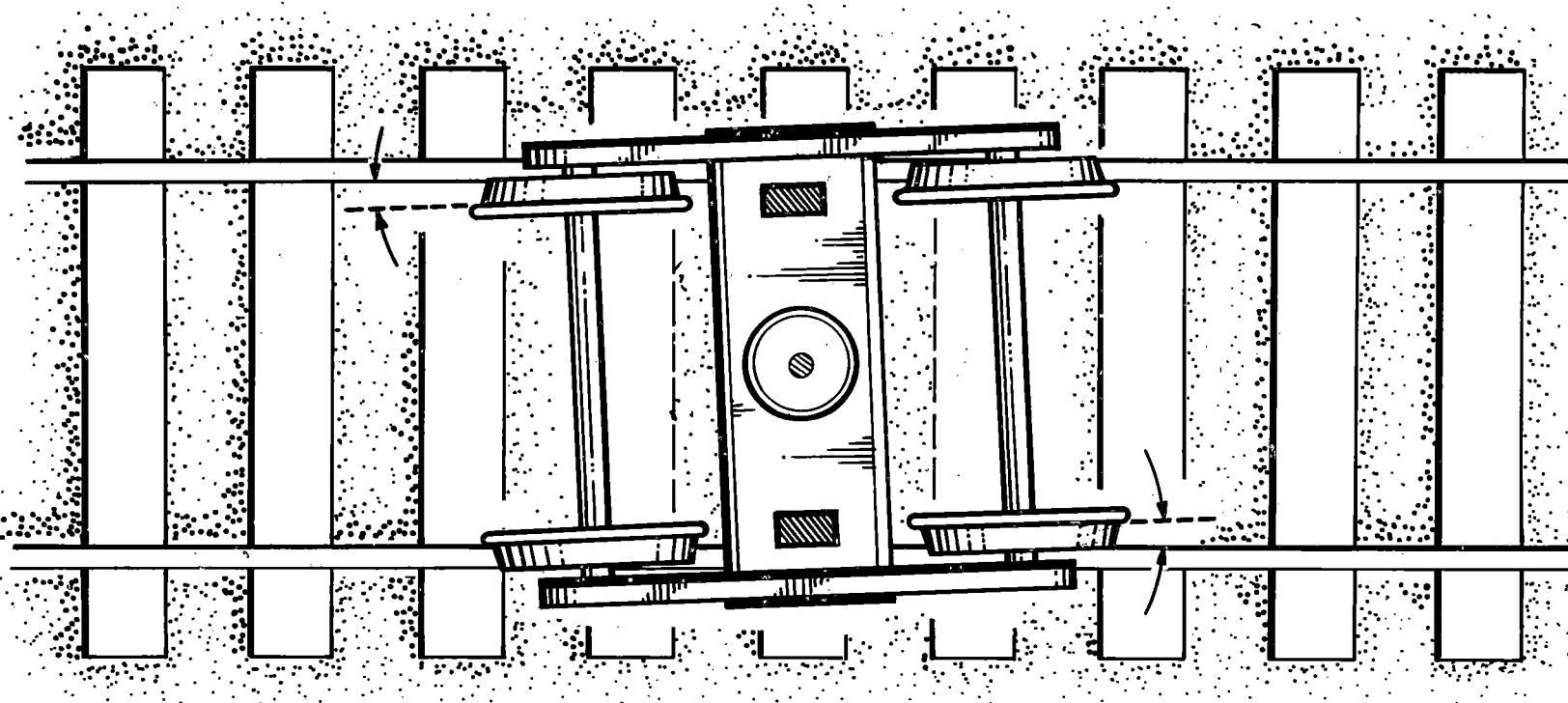

Two types of hunting were noted. In one, the action of the truck was associated with substantial lateral motion of the car body--yaw, high-center roll, nosing or fishtailing. The second type occurred in the absence of such motion, or at least amid negligible car motions. In these instances, the truck itself experienced the yaw or lateral movement.

Both types of hunting produced hard contact between wheel and rail, however, causing short duration increases of gage up to 3/8 inch. Gage increases greater than 1/10 inch beyond the unloaded, rest-position gage are considered prima facie evidence of hunting.

With that criterion for hunting established, the Battelle group reported that about five per cent of the freight cars traveling between 55 and 80 miles per hour experience hunting.

The greater the speed, the more common the hunting and the more severe the gage amplitudes developed. Because of their effect on lateral/vertical force ratios, however, it was noted that high axle loads tended to decrease the likelihood of hunting.

Locomotives, for example, were rarely found to produce gage differences that could be defined as hunting, despite their perceived effect on track instability.

Truck hunting was found not to contribute significantly to the torque that causes rail rollover. But lower frequency car dynamics such as car roll or yaw will contribute heavily to transverse torque. These factors are common to heavy, high-center-of-gravity cars.

A more significant factor in the frequent occurrence of high torque levels is frozen ballast. As trains roll over track, the track, ties and roadbed all give a little, absorbing some of the forces transmitted by the wheels. But when the ballast is frozen, the ties cannot give and the rail must absorb the full force of the train.

Study has indicated that the lateral forces transmitted through the spikes are not sufficient to rip the spike from the tie, because some of that force can be absorbed into the tie itself. But the torque effect in winter, when the tie could not give with the transmitted forces, was about 40 per cent higher than in the summer.

The Battelle group concluded that additional spikes cannot mitigate the torque problem, although they would help hold gage more precisely.

The wide gage study has been followed up with spot checks which will determine the long-range effects of track/train interactions on the wide gage phenomenon.

The group also recommended that further studies be conducted on curved track.

## PHASE TWO PLANNING

Before the end of the first phase of the national research program, the Phase Two Planning effort was begun. The Phase Two effort has been outlined in a 71-page program plan submitted by Dr. David

Sutliff, the program director for Phase Two. Dr. G. C. Martin, who has served as deputy director of the Phase One effort under director E. F. Lind, will continue as deputy director of the Phase Two effort. Keith Hawthorne, the AAR's manager of safety research, has also been named a deputy director of Phase Two.

This phase will deal with the development of performance specifications for track and equipment, relying on the modelling and testing efforts of Phase One for input information.

The Phase Two effort will be divided into several major effort areas, which are described below.

Track structures. Two classes of specifications will be developed in this effort. The first are specs that ensure structural integrity of track components and the entire track structure. Such specifications might include fatigue levels for ties, ballast and joint bars. These would also include material specifications, such

**PHASE II  
ESTABLISHMENT OF  
PERFORMANCE SPECIFICATIONS  
FOR THE DESIGN OF TRACK,  
ROLLING STOCK AND COMPONENTS**

as standards for the electrical resistance of rails.

The second class of specs will assure adequate track/vehicle behavior. These will define the line and surface of rail, degree of curvatures and limits for superelevation. They will also define the ranges in which these factors can vary from the ideal values.

Wheel/rail system. The wheel/rail contact is the transmission point for all the forces, adverse and desirable, that shift between train and track. Adverse dynamic interactions lead to increased wheel/rail wear and to premature failure of both components. Many studies of wheel and rail structure are already underway and the wheel/rail study will glean information from these. In addition, an examination of contact loads and stresses will be conducted by the groups.

Trucks and suspension. Performance specifications for trucks also fall into two categories. The first deals with the truck as a system. Ride quality, stability, damping and curving abilities are included in the specifications for the system. The second category includes the individual components within the truck. Fatigue specifications and performance requirements for these components will be designed with the entire system in view.



Car and locomotive body structures. Specifications to avoid fatigue failures will be a major thrust of this effort, which will also rely on in-house standards already in existence at AAR. Analyses of loading and the environment of operation will also be entered into the formulation of these final specifications.

Couplers, yokes, draft gears and cushion units. Coupler and yoke specifications will make up the first area of study in this effort. Increased locomotive power and high capacity cars presently have increased the strains on the coupler mechanisms. The coupler study will rely somewhat on the ongoing AAR Coupler Safety Project, but additional tests will be added and specifications designed as needed.

The second area of study will include standards of performance for draft gears and cushioning units. These will be designed to protect the lading and car body structure during yard and over-the-road operations.

Brake systems. Again, specifications are divided into two categories. The first deals with the effects of brake system parameters on train performance. The second deals with performance of the brake components themselves.

The first effort will involve the setting up of a priority system for brake/train response. For example, the standards will require a system that is durable, does not lead to excessive longitudinal forces, does not cause excessive wheel wear, and provides

reliable service, among other things.

The second will include standards for valves, pressure lines, leakage, brake shoe coefficients and other factors.

As in the Phase One effort, the Phase Two studies will require some testing of equipment. These tests will be handled by a Test Management group, charged with responsibility for the tests only and which will be directly responsible to the project director.

Another group within the Phase Two study will be the Program Analysis group. This group will analyze and report on the advantages and disadvantages of proposed specifications. This analysis will include life cycle costs of new designs, cost-benefit analyses, risk studies and failure analyses. The Program Analysis group will also recommend priorities for the implementation of the specifications developed.

The last group in the list is the Advanced Analytical Techniques group. This group will seek out new stress testing methods and attempt to design more economical stress and failure study methods.

The several studies in the Phase Two effort will pick up where the Phase One effort ended, continuing the research program for another three years. The effort is designed to take the knowledge developed in Phase One and use the knowledge to improve equipment design and standards, at a cost both feasible and attractive to the industry. The organization of the Phase Two effort is displayed in Figure 32.

FIGURE 32: PHASE TWO ORGANIZATION AND ACTIVITIES CHART

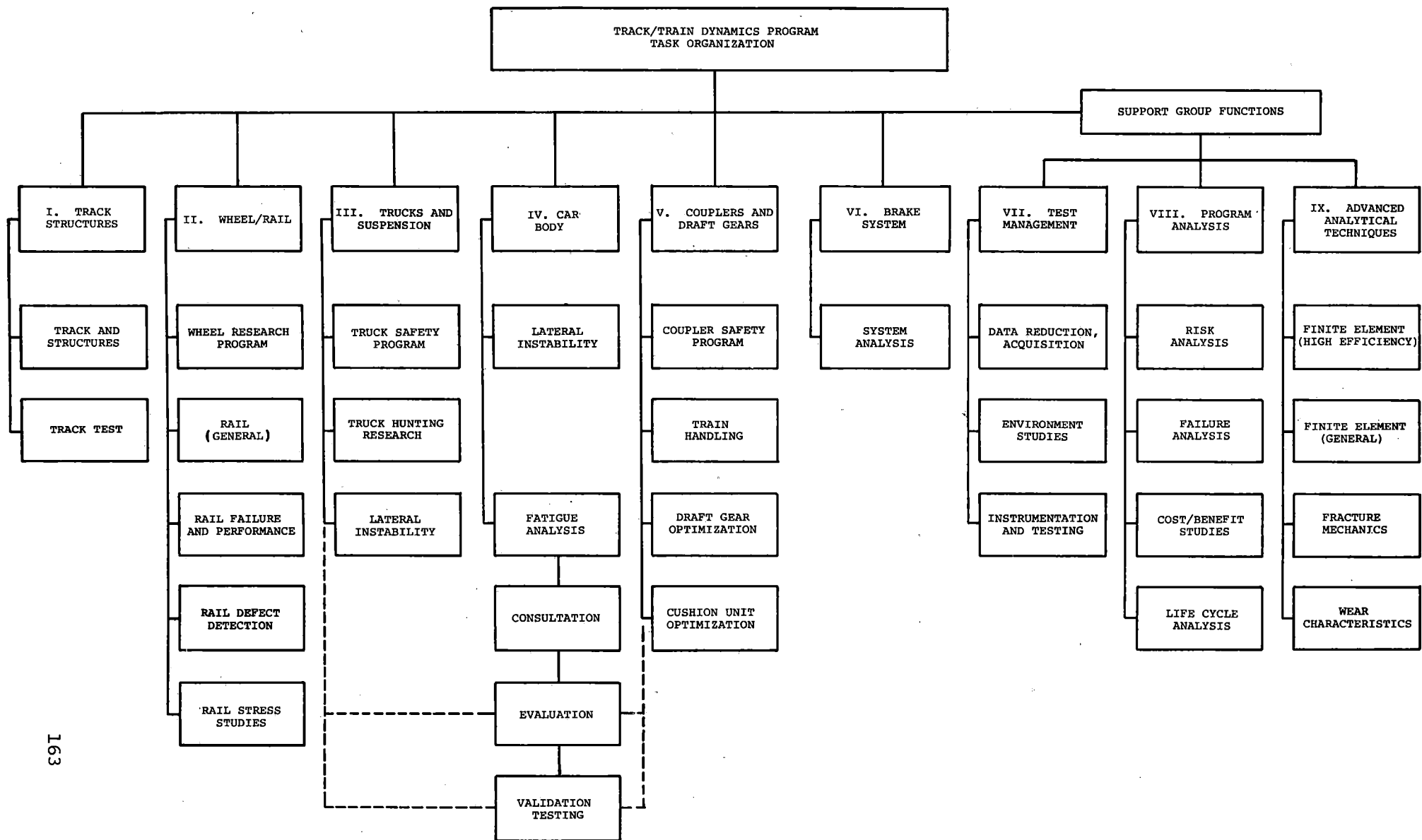

## PHASE ONE PROGRESS AND CONCLUSIONS

As the several Phase One studies reach completion and the first segment of the International Research Program on Track/Train Dynamics nears its close, it is incumbent upon those involved and those interested in the railroad industry to review the achievements and progress obtained during the past three years.

The achievements have been substantial. Beginning with a small foundation and without even a system of detailed references to fall back on, the people involved in the Phase One studies have built a strong base from which future endeavors can be launched.

At the start of this study, and when it was first suggested to the AAR, the subject of track/train dynamics was looked upon as fertile--and for the most part virgin--territory.

Several individual studies had been conducted by individual railroads and supply companies, but dynamic problems that confronted the industry as a whole had not been tackled by all those adversely affected.

The effort required the same type of teamwork that resulted a few years ago in the first lunar landing. At the beginning of the space program, several individual studies had been conducted also, and many of the obstacles to space exploration were already known. But in that case, as in this, it took a concerted effort by government, industry and academia to bring the desired results to fruition.

The space program was perhaps more dramatic than the study of track/train dynamics, but the practical applications of the information obtained in this program will reap dramatic financial, safety, and operational improvements.

As has been mentioned elsewhere in this document, the first attack launched against the problems of track/train dynamics was three-pronged.

First, the people involved in the effort undertook the assignment of making present railroad equipment and operations more efficient, safer and less prone to damage and accidents.

Second, they amassed complete reference and reporting systems through laboratory and field testing, for future studies of track/train interactions.

And third, they developed mathematical models of track/train behavior, for use in testing operating procedures and in future studies.

The accomplishments made in these areas have been notable and a most satisfactory start for the project as a whole. Although some delays occurred which pushed completion dates back for several studies, the program was completed--only slightly behind the original schedule.

The accomplishments of the Phase One effort, briefly, are as follows:

A complete reference system has been developed, containing written data on the dynamics of track and train systems. The ma-

materials have been referenced into the AAR Bibliography, a three-volume work, and have also been incorporated into the FRA's Railroad Research Information Service.

Detailed Guidelines for train handling have been devised and distributed. As a result of this achievement, railroads can now improve their operating efficiency, safety and finances with present equipment.

Railroad accident investigation procedures have been improved and codified in light of new understandings of track/train interactions.

Railroad officials and suppliers can now have a more complete understanding of the forces present in train action. This understanding can lead to new improvements in equipment design and usage.

Mathematical models of train actions are now available for general use. These versatile models can be used in a number of ways to predict force levels in moving trains, to determine safe and risky train make-up, to test equipment in areas considered unsafe for real equipment and personnel, to test out proposed equipment on paper before subjecting the components to costly and time-consuming real-world tests, and to study and improve train-handling techniques.

The input of engineers into track/train dynamics has come under study, with consideration of several train-handling aids and new training programs underway.

And a solid foundation has been laid for future studies,

studies which will build upon the base developed by the people involved in the Phase One effort.

In mid 1975, all the documents listed in the next few pages will be distributed. Many are already available.

Railroad and industry and government officials interested in the detailed Phase One studies can obtain copies of these documents, as well as other materials available through the AAR.

This document, and the balance of the output from Phase One provides a detailed and comprehensive view of the state of the railroad understanding of dynamic interactions, and a demonstration of the progress that has been made in that art over a few short years.

## OTHER RESEARCH PROGRAM DOCUMENTS

Outline of a National Research Program prepared by Southern Pacific Transportation Company for AAR - 2 volumes - March 1972

Track Train Dynamics "Bibliography" - a 3 volume publication outlining in abstract form the contents of over 600 articles relating to TTD, including an extensive thesaurus and key word index - March 1973

TTD "Interim Guidelines" for optimum Train Handling, Train Make-up, Track Considerations, etc., based on the best present state-of-the art practices. To be continually updated as research progresses - 2 volumes - November 1973

Track Train Dynamics Guidelines updated for Optimum Train Handling, Train Makeup, Track Considerations, etc. These results are based on a parametric study using our analytical model.

Accident Investigation - recommended procedures to accurately determine causes of dynamically-related derailments and corrective action to be taken.

User & Technical Documentation for our Mathematical Models - a series of documents outlining how the various programs can be used - the advantages and disadvantages associated with each program and the engineering details contained in each of the models.

Volume I - Harmonic Roll Series - a comprehensive review of the problem, relationship of track and car design to the problem, recommended guidelines, based on best of the present knowledge, etc., November 1974

Volume II - Harmonic Roll Series - a documentation of the American Steel Foundries work in developing characteristics of the 70 ton truck components, physical restraints, mechanical properties, etc., February 1975.

Volume III - Harmonic Roll Series - a document dealing with work done by the Track Train Dynamics Program to develop comprehensive vehicle models to predict dynamic behavior and perform parametric studies. Also included in this document is work done by A. Stucki Co., to evaluate the effect of eccentric loading on the roll tendencies of various vehicles.

Volume IV - Harmonic Roll Series - a document dealing with work



done by ACF Industries & Pullman-Standard to generate torsional and flexural stiffness characteristics of various car types. These are to be incorporated into our vehicle models.

Truck & Car Body Characterization - This document covers work done by NASA & Martin Marrietta in characterizing the non-linearities of a particular assembled truck type, the development of information on car body characteristics and the establishment of transfer function data between car body and truck.

Volumes I (summer test) and II (winter test) - Wide Gage - a document dealing with work done by Track Train Dynamics, Battelle Memorial Institute and the Union Pacific Railroad to determine the effects of such phenomena as axle loadings, speed, truck characteristics, etc., on the deterioration of gage on various track sections at Pocatello, Idaho.

Instrumentation & Testing Activities - This document describes all the activities associated with the SP Steel Coil Train test, the L/V and Lateral Train Stability test and the Vertical Train Stability test. It also demonstrates the use of the data in validating our mathematical models.

Engineman Sensitivity Studies - detailing the effort which examined the perception and response of enginemen to track/train and car/car interactions.

Midland-Ross Studies - a document concerning the study by National Castings Division of Midland-Ross Corp. into lateral angling characteristics of draft gear systems.

Proceedings from the first TTD Seminar - 2 volumes - December 1971.

The Proceedings from the Second Track Train Dynamics Seminar held in Chicago in December, 1974.

International Research Program on  
**Track/Train Dynamics, Phase I Report, 1975**  
Association of American Railroads

6N035 00V5395

PROPERTY OF FRA  
RESEARCH & DEVELOPMENT  
LIBRARY