

# MEASUREMENT AND CORRELATION ANALYSIS PLAN FOR CONCRETE TIE AND FASTENER PERFORMANCE ANALYSIS



**NOVEMBER 1979**

**INTERIM REPORT**

Document is available to the public through the  
National Technical Information Service,  
Springfield, Virginia 22161.

Prepared for  
**U.S. DEPARTMENT OF TRANSPORTATION**  
**FEDERAL RAILROAD ADMINISTRATION**  
**Office of Research and Development**  
**Washington, D.C. 20590**

01-Track & Structures

#### NOTICE

This document is disseminated under the sponsorship of the Department of Transportation in the interest of information exchange. The United States Government assumes no liability for its contents or use thereof.

#### NOTICE

The United States Government does not endorse products or manufacturers. Trade or manufacturers' names appear herein solely because they are considered essential to the object of this report.

|  |  |  |   |  |           |
|--|--|--|---|--|-----------|
| 1. Report No.<br>FRA/ORD-79/51   |  | 2. Government Accession No.                          |   | 3. Recipient's Catalog No.   |           |
| 4. Title and Subtitle<br>MEASUREMENT AND CORRELATION ANALYSIS PLAN<br>FOR CONCRETE TIE AND FASTENER PERFORMANCE<br>EVALUATION  |  |  |   | 5. Report Date<br>November 1979  |           |
|  |  |  |   | 6. Performing Organization Code  |           |
| 7. Author(s)<br>F.E. Dean* H.D. Harrison* R.H. Prause,*<br>E.T. Selig** and D. McMahon**   |  |  |   | 8. Performing Organization Report No.  |           |
| 9. Performing Organization Name and Address<br>*Battelle Columbus      **Dept. of Civil Engineering<br>Laboratories              University of Massachusetts<br>505 King Avenue           Amherst, Mass. 01003<br>Columbus, OH 43201   |  |  |   | 10. Work Unit No. (TRAVIS)   |           |
|  |  |  |   | 11. Contract or Grant No.<br>DOT-FR-8164   |           |
| 12. Sponsoring Agency Name and Address<br>U.S. Department of Transportation<br>Federal Railroad Administration<br>Office of Research and Development<br>Washington DC 20590  |  |  |   | 13. Type of Report and Period Covered<br>Interim Report<br>October - December 1979 |           |
|  |  |  |   | 14. Sponsoring Agency Code<br>RRD-32   |           |
| 15. Supplementary Notes  |  |  |   |  |           |
| 16. Abstract<br><br>This report was prepared as part of the Improved Track Structures Research Program sponsored by the Office of Rail Safety Research of the Federal Railroad Administration. The report presents an experiment plan and a correlation methodology through which the long-term performance of concrete tie track will be evaluated.<br><br>The experiment plan defines test segments, instrumentation and measurement procedures for a comprehensive evaluation, over a two-year period, of three concrete tie test sections and one wood tie control section, all of which are installed on revenue service track. This evaluation is to be correlated with similar track performance data from the Facility for Accelerated Service Testing (FAST). Formats for FAST data to be requested from the Transportation Test Center are summarized. Finally, the methods of direct comparison, regression and analytical simulation, by which track performance at FAST and on the revenue service will be compared, are defined. |  |  |   |  |           |
| 17. Key Words<br>Concrete Cross Ties, Track Performance,<br>Ties and Fasteners, Track Testing  |  |  | 18. Distribution Statement<br>Document is available to the U.S. public<br>through the National Technical<br>Information Service, Springfield,<br>VA 22161 |  |           |
| 19. Security Classif. (of this report)<br>Unclassified   |  | 20. Security Classif. (of this page)<br>Unclassified |   | 21. No. of Pages   | 22. Price |

## PREFACE

This interim technical report presents an experiment plan and a correlation methodology through which the long-term performance of concrete tie track will be evaluated. The report was prepared by Battelle's Columbus Laboratories and the University of Massachusetts in fulfillment of the first major requirement of the performance study, which is called the Concrete Tie and Fastener Performance and Correlation Analysis. The study is sponsored by the Federal Railroad Administration, Office of Rail Safety Research, as part of a larger program to improve the economics and safety of track structures in U.S. service, called the Improved Track Structures Research Program.

The prime contractor for this work is Battelle's Columbus Laboratories. Mr. Robert Prause of Battelle is the project manager. The University of Massachusetts is a subcontractor for investigations of ballast and subgrade, and this work is under the direction of Dr. Ernest Selig. Mr. John Weber, a private consultant, will assist in conducting inspections of the concrete ties at the various test segments.

Mr. Howard Moody of the FRA is the Contracting Officer's Technical Representative. His support and suggestions in the preparation of this plan are gratefully acknowledged. This work was performed under Letter Contract No. DOT-FR-8164.

### Approximate Conversions to Metric Measures

| Symbol                     | When You Know             | Multiply by                      | To Find                | Symbol          |
|----------------------------|---------------------------|----------------------------------|------------------------|-----------------|
| <b>LENGTH</b>              |                           |                                  |                        |                 |
| m                          | inches                    | 2.5                              | centimeters            | cm              |
| ft                         | feet                      | 30                               | centimeters            | cm              |
| yd                         | yards                     | 0.9                              | meters                 | m               |
| mi                         | miles                     | 1.6                              | kilometers             | km              |
| <b>AREA</b>                |                           |                                  |                        |                 |
| in <sup>2</sup>            | square inches             | 6.5                              | square centimeters     | cm <sup>2</sup> |
| ft <sup>2</sup>            | square feet               | 0.09                             | square meters          | m <sup>2</sup>  |
| yd <sup>2</sup>            | square yards              | 0.8                              | square meters          | m <sup>2</sup>  |
| mi <sup>2</sup>            | square miles              | 2.6                              | square kilometers      | km <sup>2</sup> |
|                            | acres                     | 0.4                              | hectares               | ha              |
| <b>MASS (weight)</b>       |                           |                                  |                        |                 |
| oz                         | ounces                    | 28                               | grams                  | g               |
| lb                         | pounds                    | 0.45                             | kilograms              | kg              |
|                            | short tons<br>(2000 lb)   | 0.9                              | tonnes                 | t               |
| <b>VOLUME</b>              |                           |                                  |                        |                 |
| tsp                        | teaspoons                 | 5                                | milliliters            | ml              |
| Tbsp                       | tablespoons               | .15                              | milliliters            | ml              |
| fl oz                      | fluid ounces              | 30                               | milliliters            | ml              |
| c                          | cups                      | 0.24                             | liters                 | l               |
| pt                         | pints                     | 0.47                             | liters                 | l               |
| qt                         | quarts                    | 0.95                             | liters                 | l               |
| gal                        | gallons                   | 3.8                              | liters                 | l               |
| ft <sup>3</sup>            | cubic feet                | 0.03                             | cubic meters           | m <sup>3</sup>  |
| yd <sup>3</sup>            | cubic yards               | 0.76                             | cubic meters           | m <sup>3</sup>  |
| <b>TEMPERATURE (exact)</b> |                           |                                  |                        |                 |
| °F                         | Fahrenheit<br>temperature | 5/9 (after<br>subtracting<br>32) | Celsius<br>temperature | °C              |

AE

# METRIC CONVERSION FACTORS

## Approximate Conversions from Metric Measures

| Symbol                     | When You Know                     | Multiply by       | To Find                | Symbol          |
|----------------------------|-----------------------------------|-------------------|------------------------|-----------------|
| <b>LENGTH</b>              |                                   |                   |                        |                 |
| mm                         | millimeters                       | 0.04              | inches                 | in              |
| cm                         | centimeters                       | 0.4               | inches                 | in              |
| m                          | meters                            | 3.3               | feet                   | ft              |
| m                          | meters                            | 1.1               | yards                  | yd              |
| km                         | kilometers                        | 0.6               | miles                  | mi              |
| <b>AREA</b>                |                                   |                   |                        |                 |
| cm <sup>2</sup>            | square centimeters                | 0.16              | square inches          | in <sup>2</sup> |
| m <sup>2</sup>             | square meters                     | 1.2               | square yards           | yd <sup>2</sup> |
| km <sup>2</sup>            | square kilometers                 | 0.4               | square miles           | mi <sup>2</sup> |
| ha                         | hectares (10,000 m <sup>2</sup> ) | 2.5               | acres                  |                 |
| <b>MASS (weight)</b>       |                                   |                   |                        |                 |
| g                          | grams                             | 0.035             | ounces                 | oz              |
| kg                         | kilograms                         | 2.2               | pounds                 | lb              |
| t                          | tonnes (1000 kg)                  | 1.1               | short tons             |                 |
| <b>VOLUME</b>              |                                   |                   |                        |                 |
| ml                         | milliliters                       | 0.03              | fluid ounces           | fl oz           |
| l                          | liters                            | 2.1               | pints                  | pt              |
| l                          | liters                            | 1.06              | quarts                 | qt              |
| l                          | liters                            | 0.26              | gallons                | gal             |
| m <sup>3</sup>             | cubic meters                      | 36                | cubic feet             | ft <sup>3</sup> |
| m <sup>3</sup>             | cubic meters                      | 1.3               | cubic yards            | yd <sup>3</sup> |
| <b>TEMPERATURE (exact)</b> |                                   |                   |                        |                 |
| °C                         | Celsius temperature               | 9/5 (then add 32) | Fahrenheit temperature | °F              |

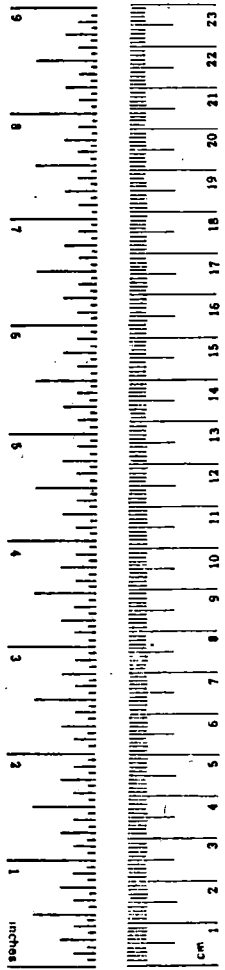
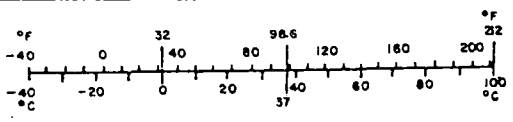

CONTENTS

|  | <u>Page</u> |
|--|-------------|
| 1. INTRODUCTION . . . . .  | 1           |
| 2. CORRELATION ANALYSIS METHODOLOGY AND PERFORMANCE<br>EVALUATION CRITERIA . . . . .           | 3           |
| 2.1 Correlation of Component Degradation . . . . .   | 6           |
| 2.1.1 Data Reductions . . . . .  | 6           |
| 2.2 Correlation of Geometry Retention . . . . .  | 9           |
| 3. MEASUREMENT AND DATA REQUIREMENTS . . . . .   | 16          |
| 3.1 Maintenance and Traffic Data . . . . .   | 16          |
| 3.2 Track Response . . . . .   | 17          |
| 3.2.1 Wheel/Rail Loads . . . . .   | 17          |
| 3.2.2 Tie Strain . . . . .   | 19          |
| 3.2.3 Rail/Tie Accelerations . . . . .   | 19          |
| 3.2.4 Rail Fastener Strain . . . . .   | 19          |
| 3.2.5 Wheel Detection and Train Speed . . . . .  | 20          |
| 3.3 Track Parameters . . . . .   | 20          |
| 3.3.1 Vertical Track Modulus . . . . .   | 20          |
| 3.3.2 Ballast Characterization . . . . .   | 21          |
| 3.3.3 Subgrade Characterization . . . . .  | 22          |
| 3.3.4 Track Lateral Restraint . . . . .  | 24          |
| 3.4 Geometry . . . . .   | 25          |
| 3.4.1 Track Geometry Car Measurements . . . . .  | 25          |
| 3.4.2 Survey-to-Benchmark . . . . .  | 26          |
| 3.4.3 Average Tie Spacing . . . . .  | 28          |
| 3.4.4 Tie Movement and Rail Creep . . . . .  | 28          |
| 3.5 Component Inspections . . . . .  | 29          |
| 3.5.1 Tie/Fastener/Pad/Insulator Inspections . . . . .   | 29          |
| 3.5.2 Gage Face Wear . . . . .   | 30          |
| 3.6 Summary of Measurement and Data Requirements . . . . .                                     | 30          |
| 4. TEST SITE DESCRIPTION AND INSTRUMENTATION PLAN . . . . .                                    | 36          |
| 4.1 Test Sites . . . . .   | 36          |
| 4.1.1 Chessie Site at Lorraine, Virginia . . . . .   | 36          |
| 4.1.2 Norfolk & Western Site at Roanoke, Virginia . . . . .                                    | 36          |
| 4.1.3 Sante Fe Site at Streator, Illinois . . . . .  | 39          |
| 4.1.4 Northeast Corridor Site at Aberdeen, Maryland . . . . .                                  | 39          |
| 4.2 Collection of Dynamic Data . . . . .   | 42          |
| 5. INSTRUMENTATION SELECTION, EVALUATION, CALIBRATION,<br>INSTALLATION AND OPERATION . . . . . | 45          |
| 5.1 Wheel/Rail Loads . . . . .   | 45          |
| 5.2 Tie Bending Strains . . . . .  | 48          |
| 5.3 Rail and Tie Accelerations . . . . .   | 54          |
| 5.4 Fastener Strain . . . . .  | 55          |
| 5.5 Wheel Detection and Train Speed . . . . .  | 56          |
| 5.6 Vertical Track Modulus . . . . .   | 59          |

CONTENTS (Continued)

|   | <u>Page</u> |
|---|-------------|
| 5.7 Field Inspection of Ballast and Subgrade Conditions . . . . .     | 60          |
| 5.7.1 Introduction . . . . .  | 60          |
| 5.7.2 Scope . . . . .   | 60          |
| 5.7.3 Information Needed . . . . .                                    | 60          |
| 5.8 Ballast Physical State Tests . . . . .                            | 62          |
| 5.8.1 Introduction . . . . .  | 62          |
| 5.8.2 Scope of Tests . . . . .  | 63          |
| 5.8.3 Test Layout . . . . .   | 69          |
| 5.8.4 Test Procedures and Apparatus . . . . .                         | 69          |
| 5.8.5 Test Schedule . . . . .   | 72          |
| 5.8.6 Additional Sampling . . . . .                                   | 72          |
| 5.8.7 Railroad Assistance . . . . .                                   | 73          |
| 5.9 Ballast Index Property Tests . . . . .                            | 73          |
| 5.9.1 Introduction . . . . .  | 73          |
| 5.9.2 Scope of Tests . . . . .  | 75          |
| 5.9.3 Test Procedures . . . . .                                       | 75          |
| 5.9.4 RR Assistance . . . . .   | 77          |
| 5.10 Subsurface Investigations . . . . .                              | 77          |
| 5.10.1 Objectives and Scope . . . . .                                 | 77          |
| 5.10.2 Test Equipment . . . . .                                       | 79          |
| 5.10.3 Test Schedule . . . . .  | 80          |
| 5.10.4 Undisturbed Sampling . . . . .                                 | 81          |
| 5.10.5 Laboratory Tests (Disturbed Samples) . . . . .                 | 82          |
| 5.10.6 Expected Results (Disturbed and Undisturbed Samples) . . . . . | 82          |
| 5.10.7 Railroad Assistance . . . . .                                  | 82          |
| 5.11 Laboratory Stress-Strain and Strength Testing . . . . .          | 83          |
| 5.11.1 Purpose . . . . .  | 83          |
| 5.11.2 Methods and Scope . . . . .                                    | 83          |
| 5.12 Moisture Monitoring and Sampling . . . . .                       | 84          |
| 5.12.1 Introduction . . . . .   | 84          |
| 5.12.2 Oven Samples . . . . .   | 84          |
| 5.12.3 Moisture Sensor Instrumentation . . . . .                      | 84          |
| 5.12.4 Moisture Sensor Installation . . . . .                         | 87          |
| 5.12.5 Moisture Sensor Calibration . . . . .                          | 87          |
| 5.12.6 Railroad Assistance . . . . .                                  | 90          |
| 5.13 Weather Information . . . . .                                    | 90          |
| 5.14 Survey-to-Benchmark Measurements . . . . .                       | 91          |
| 5.14.1 Initial Installation . . . . .                                 | 91          |
| 5.14.2 Vertical Elevation Measurements . . . . .                      | 91          |
| 5.14.3 Horizontal Distance Measurements . . . . .                     | 91          |
| 5.14.4 Longitudinal Rail Movement Measurements . . . . .              | 95          |
| 5.15 Tie Movement Measurements . . . . .                              | 96          |
| 5.15.1 Equipment . . . . .  | 96          |
| 5.15.2 Measurement Procedure . . . . .                                | 96          |
| 5.16 Rail Creep Measurements . . . . .                                | 96          |
| 5.16.1 Markings . . . . .   | 96          |
| 5.16.2 Measurements . . . . .   | 97          |
| 5.17 Tie/Fastener/Pad/Insulator Inspection . . . . .                  | 97          |
| 5.17.1 General . . . . .  | 97          |
| 5.17.2 Inspection Procedure . . . . .                                 | 99          |



CONTENTS (Continued)

|  | <u>Page</u> |
|--|-------------|
| 5.18 Gage Face Wear . . . . .                | 100         |
| 5.18.1 Measurement Locations . . . . .       | 100         |
| 5.18.2 Equipment . . . . .                   | 100         |
| 5.18.3 Measurement Procedure . . . . .       | 101         |
| 6. RAILROAD SUPPORT REQUIREMENTS . . . . .   | 102         |
| 6.1 Surface-and-Line Maintenance . . . . .   | 102         |
| 6.2 Track Geometry Measurements . . . . .    | 102         |
| 6.3 Locomotive and Car . . . . .             | 103         |
| 6.4 Maintenance and Traffic Data . . . . .   | 103         |
| 6.5 General Assistance . . . . .             | 104         |
| 6.6 Track Time . . . . .                     | 105         |
| 7. DATA ACQUISITION AND RECORDING . . . . .  | 106         |
| 8. DATA ANALYSIS PROCEDURES . . . . .        | 108         |
| 8.1 Data Formats . . . . .                   | 108         |
| 8.2 Acceleration Data Requirements . . . . . | 111         |
| 9. FAST TRACK PERFORMANCE DATA . . . . .     | 115         |
| REFERENCES . . . . .                         | 120         |

ILLUSTRATIONS

Figure

|  |    |
|--|----|
| 2-1. Track Model . . . . .   | 11 |
| 2-2. Procedure for Exercise of Vertical Response Models . . . . .                                  | 14 |
| 2-3. Measurements to Establish Substructure Definition for<br>Vertical Response Analysis . . . . . | 15 |
| 4-1. Layout of Measurements on Concrete Tie Test Section<br>at Lorraine, Virginia . . . . .        | 37 |
| 4-2. Layout of Measurements on Concrete Tie Test Section<br>at Roanoke, Virginia . . . . .         | 38 |
| 4-3. Layout of Measurements on Concrete Tie Test Section<br>at Streator, Illinois . . . . .        | 40 |
| 4-4. Layout of Measurements on Wood Tie Control Section<br>at Streator, Illinois . . . . .         | 41 |
| 4-5. Distribution of Data Channels to Multiplex Units<br>and Tape Recorder . . . . .               | 43 |

ILLUSTRATIONS (Continued)

| <u>Figure</u>   | <u>Page</u> |
|---|-------------|
| 5.1-1. Strain Gage Circuits to Measure Lateral and Vertical Wheel/Rail Loads, for Long-Term Installation on Concrete Ties. . . . .        | 46          |
| 5.2-1. Fixture for In-Situ Calibration of Tie Bending Strain . . . . .  | 49          |
| 5.2-2. Strain Gage Coupon for Installation on Concrete Ties . . . . .   | 51          |
| 5.2-3. Strain Coupon Installation . . . . .   | 52          |
| 5.5-1. Example of Use of Wheel Detector Transducer to Provide Wayside Data Peak Detection and A/D Conversion in Data Processing . . . . . | 57          |
| 5.5-2. Wheel Detector Transducer Signal Conditioning . . . . .  | 58          |
| 5.8-1. Schematic Illustration of In-Situ Ballast Density Apparatus . . . . .  | 64          |
| 5.8-2. Schematic Illustration of Plate Load Test Apparatus . . . . .  | 65          |
| 5.8-3. Schematic Illustration of Lateral Tie Push Test Apparatus. . . . .   | 66          |
| 5.8-4. Typical Layout of Physical State Tests in Ballast . . . . .  | 70          |
| 5.8-5. Typical Cross Section of Ballast Physical State Tests . . . . .  | 74          |
| 5.8-6. Sample Processing Flow Chart for Ballast and Subballast Index Tests . . . . .  | 76          |
| 5.12-1. Cylindrical Sensor . . . . .  | 86          |
| 5.12-2. Typical Calibration Curves (Type A Sensor) . . . . .  | 89          |
| 5.14-1. Typical Benchmark Construction . . . . .  | 92          |
| 5.14-2. Placement of Benchmarks in a Typical 400-Foot Test Section . . . . .  | 93          |
| 5.14-3. Survey-to-Benchmark Measurement Schemes . . . . .   | 94          |
| 5.17-1. Tie/Fastener/Pad/Insulator Inspection Form . . . . .  | 98          |
| 7-1. Block Diagram of BCL Field Data Acquisition System . . . . .   | 107         |
| 8-1. Peak Lateral W/R Load Statistics for All Traffic, All Speeds, All Measurement Sites (0.6 Kip Load interval). . . . .                 | 110         |

LIST OF TABLES

| <u>Table</u> |   | <u>Page</u> |
|--------------|---|-------------|
| 2-1.         | Summary of Performance Measures and Track Characteristics . . .                                   | 5           |
| 3-1.         | Assumed Axle Population Statistics for Each Test Site<br>Involving Dynamic Measurements . . . . . | 18          |
| 3-2.         | Predicted Duration of Tests to Achieve Specified Statistical<br>Limits (Days) . . . . .           | 18          |
| 3-3.         | Summary of Required Data and Data Reductions . . . . .  | 31          |
| 4-1.         | Dynamic Track Response Measurements . . . . .   | 44          |
| 5.8-2.       | Required Test Apparatus and Equipment . . . . .   | 71          |
| 8-1.         | Statistical Data Processing Range and Increment<br>Requirements . . . . .                         | 109         |
| 8-2.         | Summary of Track Dynamic Response Measurement Data Format<br>Requirements . . . . .               | 112         |
| 8-3.         | Data Processing and Formats for Track Vertical Accelerations .                                    | 114         |
| 9-1.         | Summary of Fast Track Performance Data Requirements . . . . .                                     | 116         |

## 1. INTRODUCTION

The study for which this plan was developed will compare the long-term performance of selected concrete tie segments in U.S. revenue service, and of one wood tie control section, with similar performance data from the Facility for Accelerated Service Testing (FAST). A knowledge of long-term track performance is critically important in the development of new track systems. FAST was designed to accumulate long-term performance data by acceleration of the service life of both the 5-mile track loop and its 76-car test train. For more than two years, tonnage has been accumulated on a variety of track systems, including many combinations of concrete ties and fasteners, at rates 7 to 10 times higher than average revenue service.

However, FAST represents only one among many service environments, which fall in broad ranges of traffic and climatic conditions and track structure configurations. This raises the question of: "How can FAST data be extrapolated to represent the 'real world' of revenue service?" The Tie/Fastener Performance and Correlation Analysis was designed to answer this question by using data for a limited number of concrete tie test segments in revenue service and thereby to develop a methodology by which track performance can be related between track segments of dissimilar construction, contour, service loads and climate. This report describes the methodology to be applied to the task of correlation, and provides a detailed experiment plan for completion of the measurement program.

The data required for this correlation analysis will be collected through the following activities:

a. Revenue Service Performance Measurements. Three concrete tie test segments and one wood tie control segment, all on revenue service track, will be subjected to periodic assessments of track performance by measurements on the rails, fasteners, ties, ballast and subgrade. A total of 5 data sets will be collected during 4 visits to each site over a period of approximately 2 years. During the first site visit, instrumentation will be installed and data will be collected both before and after surface-and-line maintenance.

The locations of the test sites are:

- (1) Lorraine, Va. (Chessie System) - concrete ties
- (2) Kumis, Va. (Norfolk & Western) - concrete ties

(3) Streator, Illinois (Santa Fe) - concrete and wood ties. An Additional program of visual inspection and track geometry measurements will be conducted on a segment of the newly installed concrete tie track of the Northeast Corridor near Aberdeen, Maryland.

b. FAST Data. A request for performance data from selected concrete and wood tie segments at FAST will be submitted through the Federal Railroad Administration to the Transportation Test Center or the AAR.

Following the acquisition and reduction of the required track performance data, a correlation analysis will be conducted. Two basic approaches will be applied:

a. Correlation by Comparison and Regression. Direct comparisons of performance indices will be meaningful to indicate the effect of differences in traffic, construction and environment. Regression analysis will be applied to identify correlation coefficients which, when calculated from the results of two or more track segments, can be verified by correlation with results from an additional track segment.

b. Correlation by Analytical Simulation. Vertical track response analytical models, plus input data collected from laboratory measurements of ballast and subgrade materials, will be used to correlate both short-term and long-term measured performance.

## 2. CORRELATION ANALYSIS METHODOLOGY AND PERFORMANCE EVALUATION CRITERIA

The purpose of the correlation analysis is to determine the dependence of track degradation on the characteristics of track structure, traffic and climate. An ultimate objective is to develop the ability to analytically predict long-term performance. However, the current state-of-the-art in analytical prediction is limited, even for simulation of very short-term phenomena, and can be applied to long-term performance only in relative terms for a few performance measures.

The correlation effort is required if data from FAST are to be extrapolated to the conditions of typical revenue service. For some or all of the selected revenue service test segments, differences with FAST conditions include:

- a. Rail size
- b. Types of fasteners and pads
- c. Track contour
- d. Track class
- e. Maintenance frequency for vehicles and track
- f. Traffic - average axle load, speed and unbalance in curves
- g. Subgrade material
- h. Environmental factors - subgrade moisture content, temperature range, freeze-thaw cycles.

The dissimilarities in construction, traffic and environment make it imperative that the fundamental causes or governing factors of long-term track performance be identified.

To achieve this correlation, or understanding of cause and effect, the following general plan will be followed:

a. The track performance data from the revenue service test segments and from FAST will be collected and reduced. The data reductions will be generally classified into three groups:

1. Primary performance measures - measures of geometry retention and component degradation. Representative values will be plotted vs. accumulated tonnage (MGT).
2. Governing structural characteristics - vertical and lateral stiffness, fastener stiffness and toe load,

transfer function of tie pads, subgrade moisture content, subgrade elastic and plastic limits, ballast gradation and general ballast condition

3. Loading and load response - wheel/rail loads, tie and fastener strains, rail deflection.

b. A search for the dependence of performance measures on governing structural characteristics and loads will be undertaken by the simple approaches of comparison and regression.

c. Analytical simulation of vertical elastic track response and of a relative measure of vertical track settlement will be performed. The simulation of elastic response will provide confidence that the track characteristics are understood and have been adequately measured. A correlation of measured vertical settlement with an analytical **estimation based on the** predicted elastic response represents a major advance in the understanding of this important track performance measure.

Table 2-1 lists the planned measurements which fall under each of the three previously discussed categories. The objective of the correlation analysis is to define the dependence of the variables in the first category (performance measures) on the remaining two (structural characteristics and traffic/climate conditions). The following sections describe the correlation methods planned for analysis of each of the two major subdivisions of performance measures: component degradation and geometry retention.

TABLE 2-1. SUMMARY OF PERFORMANCE MEASURES AND TRACK CHARACTERISTICS

| <u>PERFORMANCE MEASURES</u>            | <u>TRACK CHARACTERISTICS</u>                               |
|--|--|
| <b>A. <u>Component Degradation</u></b> | 1. Tie Strain  |
| 1. Rail Creep                          | 2. Rail/Tie Accelerations                                  |
| 2. Gage Face Wear                      | 3. Fastener Characteristics<br>(Measurements only at FAST) |
| 3. Tie Skew and Spacing Deviations     | a. Toe Load  |
| 4. Tie Cracks and Damage               | b. Stiffness   |
| 5. Fastener/Pad Insulator:             | 4. Vertical Track Modulus                                  |
| a. Movement                            | 5. Ballast Density   |
| b. Wear and Damage                     | 6. Plate Load Resistance                                   |
| <b>B. <u>Geometry Retention</u></b>    | 7. Lateral Tie Push Resistance                             |
| 1. Deviations from Average Contour     | 8. Ballast Gradation                                       |
| a. Profile                             | 9. Ballast Material Properties                             |
| b. Alinement                           | a. Liquid & Plastic Limits                                 |
| c. Crosslevel                          | b. Specific Gravity  |
| d. Gage                                | c. Chemical Composition                                    |
| 2. Track Shift from Fixed Reference    | d. Angularity, Sphericity,                                 |
| a. Vertical settlement                 | e. Hardness  |
| b. Lateral                             | 10. Subgrade Penetration<br>Resistance                     |
| c. Longitudinal                        | a. Dutch Cone  |
|  | b. Standard  |
| <u>TRAFFIC/CLIMATE CONDITIONS</u>      | 11. Subgrade Material Properties                           |
| 1. Wheel/Rail Loads                    | a. Shear Strength  |
| a. Vertical                            | b. Resilient Modulus                                       |
| b. Lateral                             | c. Permanent Strain  |
| 2. Tonnage Accumulation                | 12. Subgrade Classification                                |
| 3. Consist Definitions                 | a. Material Identification                                 |
| 4. Train Speed                         | b. Stratification  |
| 5. Moisture History                    | c. Moisture  |
| 6. Weather Conditions                  | d. Density   |



## 2.1 Correlation of Component Degradation

### 2.1.1 Data Reductions

Results of the component inspections will be reduced to a set of comparable performance indicators, plotted vs. MGT. In some cases several alternatives are listed. The final selection of formats will depend on the range and variability found in the data. The formats selected will be those which show, with greatest statistical reliability, performance changes leading to maintenance requirements. In each case, a curve fit of the basic data reduction will yield an average rate of change of the measurement over the test period. The measurements and data reductions are:

| <u>MEASUREMENT</u>        | <u>DATA REDUCTION (PLOT VS. MGT)</u>   |
|---------------------------|--|
| 1. Rail Creep             | Mean creep<br>Percent of ties with creep exceeding selected threshold<br>Creep value exceeded by 5% of ties      |
| 2. Gage Face Wear         | Mean and standard deviation of wear  |
| 3. Tie cracks             | Percent of ties in test section with cracks exceeding 2 inches   |
| 4. Tie chips              | Percent of ties in test section with chips exceeding 1 inch in depth (Sufficient to cause further deterioration) |
| 5. Fastener Clip Movement | Percent of clips in test section with displacement greater than half way to fall-out<br>Percent of fall-outs     |
| 6. Pad Movement           | Percent with movement above 2 inches   |
| 7. Pad Deterioration      | Percent of pads in test section which are torn, cracked or delaminated   |
| 8. Insulators             | Percent seriously displaced or missing<br>Percent cracked or broken  |

It must be anticipated that many of the component inspections will yield very little variation over the period of the test. For example, the past several six-month inspections at the Chessie site have shown little or

no change in such indicators as fastener component movement or tie cracking. Although the lack of degradation is itself a meaningful performance measure, it will provide little opportunity to examine the sensitivities of component degradation to track structural and climate conditions. It will be possible to document the characteristics of structure, traffic and climate for which the components in question appear to provide a "successful" design.

For those performance indicators which display variation with respect to MGT as well as variation among test sections, a search for dependence of performance on the conditions of structure, traffic and climate will be carried out. The indicators of track condition will include the following list, as well as any additional indicators whose utility is revealed by examination of the data:

1. Traffic: mean or 5% exceedance level of vertical and lateral wheel/rail load, 5% exceedance level of tie strain
2. Track geometry
  - a. Curvature
  - b. Indices of vertical and lateral roughness - 5% exceedance values of profile and alignment
3. Ballast
  - a. Average gradation
  - b. Average density
  - c. Average lateral tie push loads
  - d. Average vertical track modulus
4. Subgrade
  - a. Stress defining elastic limit
  - b. Moisture content
5. Fasteners (Measurements only at FAST)
  - a. Toe load
  - b. Stiffness

The correlation analysis by comparison and regression will then be carried out on the following three levels:

a. Direct Comparison. Either of the following two situations would constitute a significant addition to the data bank on concrete ties:

1. Consistent performance among all test segments, indicating the independence of performance from the governing factors which differ among the test segments.
2. Consistently different performance between comparable segments of concrete and wood tie track. At Streator and at FAST, such segments can be obtained with the same contour, traffic and ballast/subgrade support conditions.

b. Plots of Performance Indices. (Rates of track roughness variation) vs. indices of the governing characteristics (load, stiffness, subgrade plastic limit, subgrade moisture content, etc). Performance differences may be explainable in these simple terms.

c. Multiple Linear Regression Analysis. This procedure will attempt to establish the possible dependence of performance indices on two or more governing characteristics. For example, the rate of increase in the 5-percent exceedance level of profile roughness error (PE) might be assumed to be a function of average axle load (V) and vertical track modulus ( $k_V$ ). Then an estimate of PE would be postulated in the form

$$PE = C_1 V^{n_1} + C_2 K_V^{n_2}.$$

From data gathered at the three track segments, the constants  $C_1$ ,  $C_2$ ,  $n_1$  and  $n_2$  could be estimated by regression analysis. The validity of the procedure (the selection of parameters and the assumed linear relationship) would be checked by using the derived coefficients to verify the measured degradation rates of other track segments.

## 2.2 Correlation of Geometry Retention

The correlation of the track geometry performance measures listed in Table 2-1 with the characteristics of track structure, traffic and climate will begin in a manner similar to the effort for correlation of component degradation rates. Indicators of performance and of track conditions will be compiled and, as a first step, will be examined for obvious connections between performance and track conditions. Where possible dependencies are identified, the methods of comparison and regression described in the previous section will be carried out for the geometry retention performance measures.

In the case of vertical track settlement, an analysis will be carried out which uses a combination of field measurements, laboratory measurements and analytical simulation of elastic response to produce a relative measure of vertical track response, or a track settlement index. The current state of the art regarding track settlement indicates that only a relatively simplified performance index is justified. However, this index should include the fundamental ballast and subgrade parameters needed for evaluating the effects of variations in track design parameters. This requires identifying the relative contributions from the ballast and subgrade to the total settlement. One possible format for a Track Settlement Index (TSI) is based on total vertical settlement per MGT of a defined traffic. This could be represented as

$$TSI = \frac{\sum_i \beta_i N_i}{\sum_i N_i P_i},$$

where  $N_i P_i$  gives the tonnage for  $N_i$  number of axles at mean axle load  $P_i$ , and  $\beta_i$  is the track settlement rate for those  $N_i$  axles.

The track settlement rate is a result of the cumulative settlement in each of  $j$  layers representing the ballast and subgrade,

$$\beta_i = \sum_j C_j \sigma_{d_{ij}}^{\alpha_j} h_j.$$

The settlement in each layer depends on the permanent strain per cycle given by  $C_j \sigma_{d_{ij}}^{\alpha_j}$  and the layer thickness  $h_j$ , where

$\sigma_{d_{ij}}$  = deviatoric stress in the  $j$  layer for the traffic of  $P_i, N_i$

$C_j$  and  $\alpha_j$  = empirical parameters for the particular material and stress condition of layer  $j$ .

The critical parameters which a track analysis model must provide are the average deviatoric stress in a layered representation of the roadbed for the statistical loading description of the railroad traffic. Other operating parameters which affect dynamic wheel loads, such as train speed, track roughness, etc., would be included by using a probability density description for wheel/rail loads to calculate the resulting roadbed stresses.

The TSI representing the rate of uniform vertical settlement can be used as the basis for estimating differential vertical settlement as a function of wavelength by using available soil settlement data and empirical results from the track tests. A separate relationship for rail profile and track cross level would permit a prediction of surface deterioration to be compared with the maximum allowable deviations under a 62-ft chord that are currently the basis for track safety standards and maintenance decisions.

In the initial stage of implementing a track surface deterioration model of this type, the traffic response is obtained using the track analysing model MULTA for static wheel/rail loads to evaluate a range of track design configurations. These track response parameters in terms of stresses and strains at any point in the layered roadbed can then be used as input to a set of transfer functions for ballast and subgrade settlement.

The Battelle-developed model of vertical elastic behavior of the track structure (MULTA) has been refined by UMASS into a program which includes an iterative procedure to handle stress-dependent properties of the subgrade material and improves computational efficiency. The result is a 3-dimensional model for which the basic components and input data are illustrated in Figure 2-1. This refinement of the MULTA model is called GEOTRACK. A detailed description of the solution process accomplished by the track analysis appears in Appendix G.

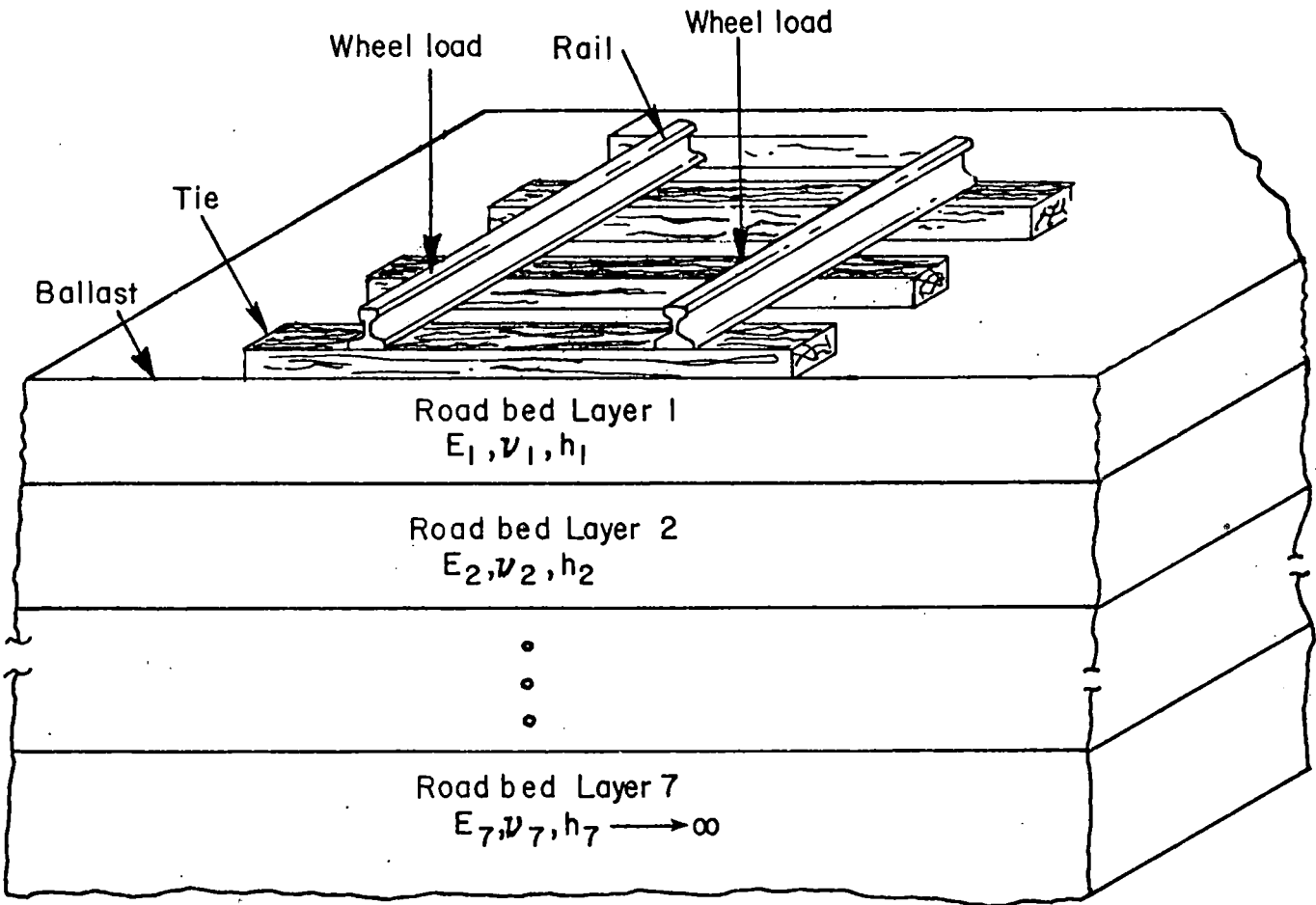

FIGURE 2-1. TRACK MODEL

This model predicts resilient behavior in terms of a complete set of stresses, strains and deformations in the track substructure, as well as rail and tie response. The results have been checked with FAST data in the ballast, subballast and subgrade on both wood and concrete tie sections. The agreement is considered good. The stress-state dependency of the elastic modulus was found to be an important feature of the model. With this feature, the model correctly predicted the nonlinear relationship between the track response parameters and the wheel load.

The present approach to permanent deformation prediction is to use the stresses from the MULTA model together with repeated load triaxial data representing the inelastic behavior of the ballast, subballast and subgrade materials. This approach predicts uniform settlement, which is in turn assumed to be a relative measure of differential settlement.

The loading data for this analysis of settlement will be an approximation of the cumulative probability distribution of vertical load for some increment of tonnage, such as 1 MGT. That is, from the measured probability distribution and the total number of load cycles involved in the tonnage increment, a set of force levels  $V_i$  and associated numbers of cycles  $N_i$  will be supplied as input to the routine. It is probable that a relatively small number of high-load cycles will account for most of the settlement.

The MULTA model permits consideration of the magnitude and frequency of train load, the type and spacing of ties, the rail stiffness, the ballast thickness and properties, the subballast thickness and properties, and the subgrade properties. However, the model assumes that each layer of material is homogeneous. Therefore, it is intended that the model predictions will be supplemented by selected analysis with the PSA model to determine the influence of variation in properties along the length of the tie.

The PSA model is a three-dimensional finite-element roadbed model that analyzes a prismatic solid which is loaded by vertical forces spaced periodically along the longitudinal track direction. The PSA model assumes the prismatic body is infinite in length with constant cross sectional and material properties in the longitudinal direction. Material properties can vary from point to point in the cross section and the geometry of the ballast section can be represented accurately. This model would be applied to represent elastic vertical force-deflection behavior in cases where measured plate-load bearing tests showed substantial variation along the length of the tie.

The planned simulation procedure is further illustrated in Figure 2-2. Figure 2-3 shows the relationship of all the information required to properly characterize the ballast, subballast and subgrade layers.



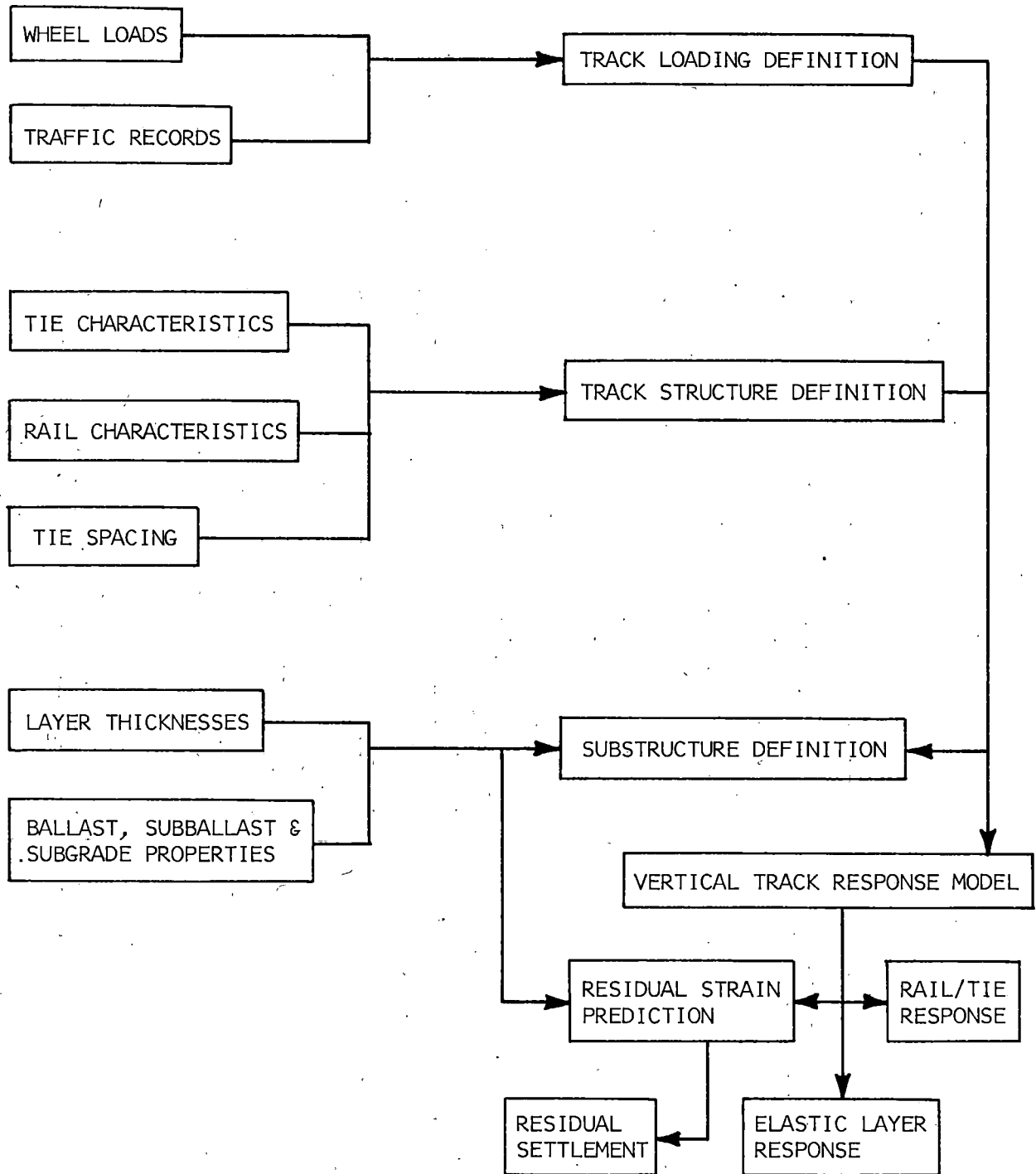

FIGURE 2-2. PROCEDURE FOR EXERCISE OF VERTICAL RESPONSE MODELS

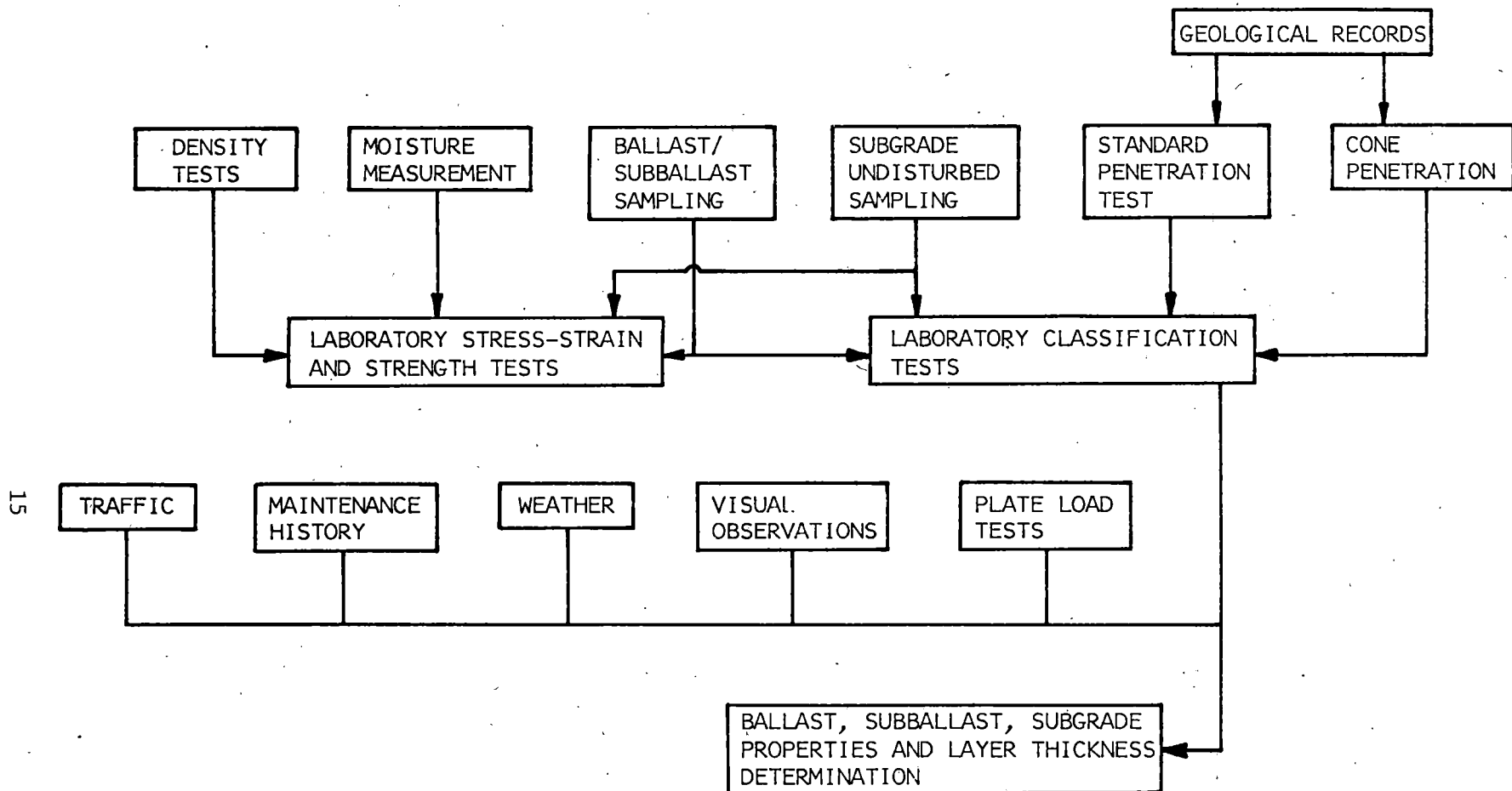

FIGURE 2-3. MEASUREMENTS TO ESTABLISH SUBSTRUCTURE DEFINITION FOR VERTICAL RESPONSE ANALYSIS

### 3. MEASUREMENT AND DATA REQUIREMENTS

#### 3.1 Maintenance and Traffic Data

Descriptions of all maintenance performed on the test section are needed for the available history of the test section. Maintenance records should include:

- a. Type of work performed
- b. Crew size
- c. Machines used
- d. Man-hours required
- e. Components replaced.

These records will be used to compile plots of maintenance activity as a function of tonnage in million gross tons (MGT) and to record rates of component replacements.

The following descriptions of traffic over the test site should be provided by the railroads to Battelle within one month after each site visit:

a. Consist Descriptions. Detailed consist descriptions for a two-week period of traffic spanning each site visit should include:

1. date and time of train passage
2. the type of each car
3. the gross weight of each car
4. the overall gross weight of the train
5. direction of travel over the test site.

b. Cumulative Tonnage. Overall train tonnage should be accumulated, beginning with the first test interval and continuing for all traffic over the test section through the full 18-month to two-year period of the tests. Data "points" should be provided in the form of the date and total accumulated tonnage at intervals no greater than one month.

In addition, any available record of tonnage accumulation since the installation of the concrete ties is desired. This long-range record should be defined at intervals no greater than three months.

At the double-track sites, care should be taken that the data provided includes only the traffic passing over the test section and not over the adjacent track.

### 3.2 Track Response

The primary requirement for dynamic track response is to determine the characteristic loads and stresses within the track structure without disturbing the tie/ballast consolidation. An evaluation of the statistics from the field tests performed under DOT-TSC-1051 provide a basis for estimating the population which can be expected at the three dynamic test sites. Listed in Table 3-1 are some of the assumed values using the statistics from the Union Pacific data and adjusting these where different traffic mixes are anticipated. From Table 3-2 it can be seen that the Lorraine and Streator sites may require five days to achieve the minimum required population while the Roanoke site may need less than three days to obtain comparable statistics. It should be noted that these figures are based on annual average tonnage and do not account for seasonal or weekly variations. The one week cycle reflects the reduced work force making up trains on the weekends. At any point on the railroad the lull in traffic will depend on the travel time from main yards and the lull in traffic in opposite directions may or may not coincide. This tends to make the timing of the specific days of dynamic data collection critical. If delays are encountered in setting up the test site for dynamic runs, one or two additional days of data collection may be necessary.

#### 3.2.1 Wheel/Rail Loads

Documenting the wheel/rail loads at each of the test sites provides a direct means of characterizing the load environment (traffic mix) for comparisons between test sites. It has been shown in previous test programs that spatial variations in wheel/rail loads on Class 5 or better track are on the same order as changes in traffic mix, so minimum gains would be made in measuring wheel/rail loads in more than one location at each test site. In other words, the scatter in loads (say  $\pm 10$  percent) measured under a certain percentile vehicle (say 20th percentile) due to spatial variations in the track will be comparable to the load variations caused by a fluctuation in traffic mix from one week to the next that will change the characteristics of that 20th percentile vehicle.

TABLE 3-1. ASSUMED AXLE POPULATION STATISTICS FOR EACH TEST SITE INVOLVING DYNAMIC MEASUREMENTS

|                           | <u>Chessie<br/>Lorraine</u> | <u>N&amp;W<br/>Roanoke</u> | <u>Sante Fe<br/>Streator</u> |
|---------------------------|-----------------------------|----------------------------|------------------------------|
| Annual Tonnage - MGT      | 35                          | 45                         | 20                           |
| Total Axles/Day           | 5200                        | 6700                       | 3000                         |
| Locomotive Axles/Day      | 200                         | 500                        | 240                          |
| Cars > 110T GVW Axles/Day | 1000                        | 1200                       | 550                          |
| Flat Wheels/Day*          | 100                         | 130                        | 60                           |

\* Measured at a 10 inch zone.

TABLE 3-2. PREDICTED DURATION OF TESTS TO ACHIEVE SPECIFIED STATISTICAL LIMITS (DAYS)

|   | <u>Chessie<br/>Lorraine</u> | <u>N&amp;W<br/>Roanoke</u> | <u>Sante Fe<br/>Streator</u> |
|---|-----------------------------|----------------------------|------------------------------|
| Load Exceedance = .01 percent<br>(All Cars, All Speeds - One Count)       | 1.9                         | 1.5                        | 3.3                          |
| Locomotive + 3 $\sigma$ Load Limits<br>(2400 lb Load Interval - 5 Counts) | 5.5                         | 2.2                        | 4.6                          |

### 3.2.2 Tie Strain

Tie strains and the corresponding bending moments induced by the wheel/rail loads vary widely due to variations in the support conditions. Therefore, tie strains must be measured in several locations to provide a statistically significant description of the tie loading environment. Five randomly selected tie locations including one location with three adjacent ties (a total of 7 ties) should be instrumented to provide documentation of short and long wavelength variations in tie support conditions.

### 3.2.3 Rail/Tie Accelerations

Time histories of rail and tie accelerations can provide a description of several dynamic properties of the track structure and the dynamic loading during train passage. Transfer functions of the fastener/pad assembly can be made from simultaneous measurement of acceleration on the rail base and the top of the tie adjacent to the rail. Spectrum analysis of these accelerations will help define the tie vibration environment, thereby improving the understanding of possible fatigue related failures. The effects of rail corrugations on the track loading is of particular interest.

### 3.2.4 Rail Fastener Strain

The failure experience of rail fasteners at FAST demonstrate the importance of further investigations of fastener performance. Statistical samplings of insertion and dynamic strain levels, including the effects of dimensional tolerances and stiffness properties of the fastener assemblies, are needed to characterize the fastener load environment. This information will be determined at FAST under a test program planned for April 1979. However, the results will be of direct value to the revenue service tests since the rail fastener being instrumented is used at all sites.

### 3.2.5 Wheel Detection and Train Speed

It will be necessary to provide wheel detectors adjacent to each instrumented tie to assist in the data reduction process. The wheel detector must provide a non ambiguous pulse for each wheel passing an instrumented location so that a discrete sample from each data channel at that location will be processed for each wheel. By measuring the distance between two wheel detectors, train speed can be determined. Speed must be calculated and logged for the beginning and end of each train.

## 3.3 Track Parameters

### 3.3.1 Vertical Track Modulus

Vertical track modulus is required to help characterize each test site. This parameter will be used to compare the characteristics of different track and is a primary input to many track models. Because track modulus can vary widely due to local support conditions under individual ties, a statistical sampling of the force/deflection measurements used to determine modulus will be required. As a minimum, static defection measurements should be made under known loads at a random sampling of tie locations throughout the entire test site on the first field trip to identify both long and short wavelength variations in modulus. This would include the five instrumented tie locations in that section of the track and a minimum of three locations in each additional section of track where tie type or spacing is varied. Spot measurements at three or four load levels will also help determine the variation between tangent and secant modulus due to local slack or free play within the track structure.

After the initial site visit a minimum of seven locations in one section of track will be measured on each successive trip to monitor variations due to commulative tonnage and seasonal variations. This number of measurements was used for recent tests in Nevada [3-1], which produced standard deviations of approximately 40 percent of the mean in each test section. This level of consistency is considered the minimum necessary to characterize differences between test sites. The wood tie section at Streator will also be measured at seven random locations on each site visit.

### 3.3.2 Ballast Characterization

Ballast and subballast are key components of the track structure. The characterization of these materials is grouped into two categories. The first category is the classification or index properties identifying the composition and properties of the components making up these materials. The second category is the physical state or structure of the material in-situ. Both categories are essential to document in order to completely define the ballast and subballast material and conditions.

The index properties will be determined in the laboratory from samples gathered on the first site visit. At present, knowledge is lacking on which index properties best identify the influence of these materials on track performance. Therefore, it is planned that all of the commonly measured index properties will be determined. The specific tests required in each case will depend upon the samples obtained, but they will include gradation, Los Angeles abrasion, particle shape, composition, specific gravity, and liquid and plastic limits of the fines. The number and type of tests in each case can remain flexible because this decision does not affect the field costs or require railroad assistance, except for providing information which might be available from their suppliers.

The physical state of the ballast in-situ will be determined directly during the site visit by field ballast density tests, plate load tests, moisture content determination, and visual observations. The physical state, particularly changes, is also affected by maintenance, weather and traffic history. Important weather information includes precipitation and temperature. The physical state information is needed to define the conditions for the laboratory stress-strain and strength tests. The information is also needed to estimate the range of property values to be considered in the analytical models. In the case of the GEOTRACK model, the variations with horizontal position and with time as a result of traffic and weather, must be considered in determining the proper average properties for each layer. The physical state information from the field will also be used to estimate variations along the tie for use with PSA model.



Maintenance and traffic are primary factors influencing ballast physical state. Information on maintenance and traffic will help to establish the initial conditions and the number of cycles of what stress levels to apply to ballast samples in the laboratory tests which measure the resilient modulus and the permanent strain development. However, maintenance and traffic history will also be used as a measure of track performance for evaluating the permanent deformation predictions.

### 3.3.3 Subgrade Characterization

The layers beneath the ballast and subballast, designated the subgrade, are usually the existing natural ground at the site. Hence, the properties of the subgrade can vary widely with depth and with distance along the track. The subgrade plays an important role in track performance because it affects such behavior as drainage, pumping, settlement under repeated traffic load, settlement from subgrade penetration into ballast, and dynamic track displacement.

A combination of field and laboratory investigations is needed to characterize the subgrade for use in the methodology. Available geological information will be obtained first to determine the expected materials and strata.

Field subsurface penetration tests to a depth of 10 to 25 ft are required to give a measure of the soil conditions at enough points along the track section to determine the variation of subgrade properties. The cone test has been selected for this purpose because it is rapid, it is not expected to disturb the roadbed significantly, and it is the simplest test that has the potential for correlation with values of soil properties required by the methodology.

Based on the results of the geological evaluation and the cone penetration tests, several representative locations will be selected for soil borings to get visual samples for identification. The Standard Penetration Test has been selected for this purpose because it is an efficient means to get suitable visual samples, and at the same time it provides values of blow count which are commonly used as a rough index of soil properties.

If the subgrade is cohesive enough, additional borings will be done to obtain undisturbed tube samples which will be taken to the laboratory for repeated load tests. If the soil cannot be obtained without disturbance, the samples will be taken anyway, and then reconstituted in the laboratory as close as possible to the field conditions before disturbance. Results from tests using reconstituted samples are much less certain, but they are better than estimations from the field investigations.

The results from the three types of field investigation will be used to define the layers for the analytical track model. As done for the ballast and subballast, repeated load triaxial tests will be performed on the subgrade samples to determine the resilient modulus and permanent strain characteristics of these materials. The results will be correlated with the field cone data to provide an assessment of the range and average of values for the entire test section. A successful correlation between the repeated load tests in the laboratory and the cone soundings in the field will have an important benefit to the railroads, because the cone method provides a rapid and economical means of obtaining property data from other sites.

Samples obtained from the Standard Penetration Test and unused portions of the tube samples will be used in the laboratory to obtain index properties on the subgrade materials which will identify the material composition. Moisture and density measurements on portions of these samples will also be used to define the physical state. Additional physical state information will be obtained in the field at the top of the subgrade using the plate load test and density test, and by obtaining samples for moisture content measurement. Moisture sensors will be implanted in the subgrade during the first site visit to provide a means of indicating changes in properties during the period of field observations.

### 3.3.4 Track Lateral Restraint

Track lateral restraint is of interest for both the loaded and the unloaded states. The first provides a measure of resistance to lateral train forces while the track is loaded by the train weight. The second is a measure of resistance to buckling from thermally-induced rail stresses. Experimental determination of lateral restraint under train load is difficult and will not be done in this program. Lateral restraint on vertically unloaded track will be measured using lateral tie push or pull tests (LTPT).

There are two types of LTPT's. One measures the resistance of an individual tie, while the other measures the resistance of panel sections connecting more than one tie. In the single tie test, the rail fasteners or spikes and tie plates are removed from the test tie, and force is applied in the lateral direction. Load levels are measured by pressure gages or load cells, while deformations are recorded by displacement transducers.

In the panel tests the ties remain attached to one or both rails. The displacement of each tie is usually measured, as is load applied to the entire panel through the rail. The panel test requires a much greater reaction force and a much more elaborate instrumentation package than does a single tie push test. The panel test also causes some disruption of train traffic, in part because of the necessity for cutting the rails. However, the panel test is more representative, because it tests the integrated system of ballast, ties, fasteners and rails. Details of the test procedures and apparatus for both types of LTPT's are discussed in reports prepared in the State University of New York at Buffalo (SUNYAB) ballast compaction study. Almost all previous experience has been on wood tie track.

Only the LTPT on the single, unfastened tie is proposed for this concrete tie correlation study. At present, little information exists to establish a correlation between these test results and lateral track restraint, particularly on a train-loaded track. More information is available to correlate the single tie LTPT to the panel test on vertically-unloaded track. Compared to the development of track structure models for vertically-loaded track, little work has been done on laterally-loaded track. Thus suitable methodology for predicting lateral track restraint still needs to be established.

The approach planned in this study is to use available information to empirically relate the single tie LTPT results measured at the test sites to lateral track stability. The single tie LTPT will be performed in accordance with procedures developed at SUNYAB for the ballast compaction study.

### 3.4 Geometry

#### 3.4.1 Track Geometry Car Measurements

Track geometry measurements of gage, alinement, profile and cross-level are to be made with the track geometry cars belonging to the railroads. The measurements should coincide as nearly as possible with the site visits. However, it is recognized that the scheduling of the track geometry cars for a specific place and time is difficult. Therefore, the only requirement for this measurement is that the runs should correspond in frequency with the interval of approximately six months planned between site visits. To the extent possible, the railroad should adhere to the following target:

- a. measurements within two weeks before and after the first site visit
- b. measurements within two weeks before or after all remaining site visits.

The major requirements for track geometry car measurements and data are as follows:

- a. Automatic location detectors should identify the beginning and end of each test segment.
- b. The data reductions normally performed by the railroads should be submitted to Battelle within 2 weeks after the completion of a run.
- c. Strip chart records of each track geometry run should be supplied to Battelle immediately after the completion of each run. The data should clearly indicate the scales of each measurement and the point of passage over each automatic location detector.

In addition to using the track geometry cars owned by the railroads, it is planned that the DOT/FRA T-6 geometry car will be operated over each of the concrete tie test sites one or more times. This will provide track geometry data which are directly comparable for the different sites and eliminate differences in track geometry measurement systems.

### 3.4.2 Survey-to-Benchmark

The track geometry measurements made by survey to benchmark (STB) will be used as a track performance indicator. The required measurements are vertical, longitudinal, and transverse movements of the rails and ties relative to fixed references. All of these measurements will be made on an unloaded track. The first set of measurements will be made before maintenance on the first visit as a basis for evaluating the maintenance operation. The second set of measurements will be made immediately after track maintenance prior to traffic. The measurements will again be repeated at the end of the first site visit and once on each subsequent site visit. Permanent ballast strain data from FAST will give an indication of the rate at which track adjustments take place after maintenance operations, and thus this FAST data can provide a guideline for the frequency of STB measurements.

The vertical track measurements will give an average and range of track settlement to compare with the permanent deformation prediction. The measurement of vertical movement is relatively easy and is the most important of the three geometry measurements.

The longitudinal measurement will indicate the movement of ties and rails resulting from such effects as thermal stress, and braking and acceleration train forces. Of interest are movements of one inch or longer, and these can be easily determined by taping from a fixed reference. However, the establishment of a stable horizontal reference is more difficult than a vertical reference.

The transverse deformation is a measure of the average and range of lateral movement from lateral track forces and from rail stresses. This measurement is the most difficult to do with sufficient accuracy, but it is of particular interest for the curve site.

Survey-to-benchmark measurements will be made at a sufficient number of sites in each test section to permit an adequate statistical description of movement trends as functions of tonnage. Ties at extreme ends of the sections will be avoided because movement in this case could be affected by the tie transition. The remaining section length will be sampled at the following rates:

- a. Chessie site (curved site) - every tenth tie
- b. All other sites - every twentieth tie.

These rates will provide about 22 measurement locations at the Chessie site and about 40 at the remaining sites. Independent surveys will be made on each side of the grade crossing at the N & W site. This sampling rate will be sufficient to identify any long-wavelength trends or variations within the test sections.

The planned measurements are summarized as follows:

a. Vertical. Elevations of the rail base and the tie surface on both sides of the track

b. Lateral. The lateral position of the rail base, relative to the fixed lines established by the benchmarks, for the rail nearest the benchmarks

c. Longitudinal. The longitudinal positions of both rails, relative to fixed transverse lines established by the benchmarks. There will be three such lines in each test section.

The major requirements of these measurements are:

a. Benchmarks. It is planned to install three benchmarks adjacent to each test section. For this purpose, the N & W site will be divided into two sections on either side of the grade crossing. Thus, for the three concrete tie sites and the one wood tie control section, a total of fifteen benchmarks will be required. This number of benchmarks is required to limit the maximum sight distance between benchmarks to 300 feet, which is about the upper limit for the establishment of sight lines and for shooting elevations.

The benchmark installation will involve drilling and casing of a hole approximately 10 inches in diameter and five feet deep. The hole beneath the casing will then be cleaned, concrete will be poured and a steel tube approximately four inches in diameter will be inserted into the concrete base and partially grouted with concrete. UMASS will assume responsibility for benchmark installation, which will be done during the preliminary site visit to obtain subsurface characterization samples. This installation will take place several weeks in advance of the "first" site visit, during which instrumentation will be installed and initial performance measurements will be taken.

b. Equipment. All lines and levels will be established with a theodolite, to be provided by Battelle. In addition, a surveyor's chain, temporary markers and other normal surveying accessories will be required.

c. Skills. An engineer with surveying experience will supervise the first survey and train selected staff, who will complete all subsequent measurements.

In Section 5.14, the construction and placement of benchmarks are illustrated and detailed procedures for the completion of vertical, lateral and longitudinal survey-to-benchmark measurements are provided.

### 3.4.3 Average Tie Spacing

As a check on the nominal design spacing of each test section, the length of the section centerline will be chained and the number of ties will be counted. Average tie spacing will be calculated from these measurements for each subsection where tie type changes.

### 3.4.4 Tie Movement and Rail Creep

All occurrences of significant spacing deviation and skew will be identified by the following procedure. A spacing bar will be prepared to indicate deviations in spacing in increments of 4 inches. A similar protractor-type device will indicate skew in the angular increments, which are equivalent to a difference in spacing, between the two ends of the tie, of 4 inches (2.25 degrees for an 8.5-foot tie). The observer will count all exceedances of the designated movement levels which fall in each section of the same tie/fastener combination.

The relative longitudinal movement between rails and ties (rail creep) will be measured at all ties where vertical and lateral STB measurements are to be made. Rail creep measurements will assess the capability of the tie/fastener/ballast system to restrain the rails. Creep markings will be painted on each field side rail base and on the adjacent tie surface. Tie movement and rail creep measurement procedures are provided in Sections 5.15 and 5.16.

### 3.5 Component Inspections

#### 3.5.1 Tie/Fastener/Pad/Insulator Inspections

Visual inspection of ties and fastener components will be made to determine the extent of tie cracking and chipping and of damage and dislocation of fastener clips, insulators and pads. The inspections will combine FAST inspection codes with the procedures used in semiannual inspections of the concrete ties at the Chessie site in Lorraine, Virginia.

It is planned to inspect the top surfaces of at least 50 ties in each concrete tie subsection of the same tie/fastener combination. The one exception to this plan will be made at the Chessie site, where top inspections of all 224 ties have been made at six-month intervals for several years. This inspection will be continued. For the remaining sites, the selection of ties within each segment of the same tie/fastener combination will be made randomly.

Tie face inspections, which require opening of cribs, will be made for at least twenty ties of each type in each test section, but only at the first and last site visits. The selection of crib locations will be made randomly except at the Chessie site, where the present scheme of crib migration will be continued. For the remaining test sections, the sites should be separated by at least three cribs. In addition, any previously identified major cracks will be inspected on each successive visit to monitor crack growth. A major crack is defined as a crack which is visible on at least two surfaces.

The major support requirement of the inspections will be for railroad labor to open and then restore the designated tie cribs. No interruption of traffic is required, since trains can operate over isolated open cribs without danger.

The top surfaces will be inspected for tie cracking, tie chipping, and damage or dislocation of the fastener clips, insulators, fastener shoulders and tie pads. Tie face cracking and damage will be recorded for the faces adjacent to the opened cribs. The inspection form and procedures are described in Section 5.17.



### 3.5.2 Gage Face Wear

Gage face wear, or the lateral position of the gage face relative to the rail web, will be measured with a snap gage of the type planned for use in the Phase II experiments at FAST. Measurement locations will be the same as for vertical and lateral STB measurements, but gage face wear will be measured only on the first and last visits.

Battelle will investigate the purchase or construction of a snap gage device. Measurement procedures are provided in Section 5.19.

### 3.6 Summary of Measurement and Data Requirements

A summary of required data and data reductions, for each experiment to be conducted or set of records to be obtained during this program, is provided in Table 3-3.

Table 3-3. SUMMARY OF REQUIRED DATA AND DATA REDUCTIONS

MEASUREMENT CYCLES <sup>(1)</sup> ↓

| MEASUREMENT                     | REQUIRED DATA  | DATA REDUCTIONS   |  |
|---------------------------------|--|---|--|
| 1. MAINTENANCE RECORDS          | <p>Descriptions of all maintenance performed on the test section, starting with the installation of concrete ties and running through the test program period. Should include:</p> <ul style="list-style-type: none"> <li>• Type of work</li> <li>• Crew size</li> <li>• Machines</li> <li>• Man-hours</li> <li>• Component replacements</li> </ul>                            | <p>Plots of MGT vs. man-hours and/or machine hours</p> <p>Cumulative length of section worked for each type of work performed</p> <p>Component replacements vs. MGT</p>   | <p>1</p> <p>2</p> <p>3</p> <p>4</p>    |
| 2. TRAFFIC DATA                 |  |   |  |
| a. Consist Definitions          | <p>For one month of traffic spanning each site visit:</p> <ol style="list-style-type: none"> <li>(1) Date &amp; time of each train passage</li> <li>(2) Type of each car</li> <li>(3) Gross weight of each car</li> <li>(4) Gross weight of train</li> <li>(5) Direction of travel and TRACK if multiple-track line.</li> </ol>  | <p>Classification of traffic:</p> <ol style="list-style-type: none"> <li>(1) in several ranges of tonnage</li> <li>(2) percent empties vs. fulls</li> <li>(3) unit trains</li> <li>(4) those travelling in each direction.</li> </ol> | <p>1</p> <p>2</p> <p>3</p> <p>4</p>    |
| b. Tonnage Accumulation         | <p>For period of time starting with earliest maintenance records and extending through completion of test program: date vs. accumulated tonnage. Record intervals should be:</p> <ol style="list-style-type: none"> <li>(1) No greater than three months for period before start of test program</li> <li>(2) No greater than one month for period of test program.</li> </ol> | <p>Tonnage accumulation is the basic independent variable for most performance plots.</p>   | <p>1</p> <p>2</p> <p>3</p> <p>4</p>    |
| 3. WHEEL/RAIL LOADS             |  |   |  |
| a. Vertical                     | <p>Vertical and lateral wheel/rail loads on both rails at one site in each test section, for all axles passing over site during the test period defined in Table 3-2</p>   | <p>Cumulative probability distributions and probability densities of traffic in several weight categories.</p> <p>Wheel/rail force vs. tie strain response and fastener clip response.</p>  | <p>1a,b</p> <p>2</p> <p>3</p> <p>4</p> |
| b. Lateral                      |  |   |  |
| 4. TIE STRAIN (BENDING MOMENTS) | <p>Calibrated tie strain at one rail seat and at tie center for seven ties, 3 consecutive and 4 isolated (randomly located) in the test section</p>  | <p>Cumulative probability distributions</p> <p>1/2-percent exceedance levels vs. MGT</p> <p>Wheel/rail force-vs.-bending moment plots</p>   | <p>1a,b</p> <p>2</p> <p>3</p> <p>4</p> |

(CONTINUED NEXT PAGE)

TABLE 3-3. (CONT.) SUMMARY OF REQUIRED DATA AND DATA REDUCTIONS

MEASUREMENT CYCLES <sup>(1)</sup>

| MEASUREMENT                  | REQUIRED DATA   | DATA REDUCTIONS  |                     |
|------------------------------|---|--|---------------------|
| 5. RAIL/TIE ACCELERATIONS    | Simultaneous measurement of acceleration on the tie and adjacent rail, for a minimum of two ties per site   | Rail/tie acceleration transfer functions   | 1a,b<br>2<br>3<br>4 |
| 6. FASTENER STRAIN           | Strains at critical points on selected fasteners, recorded simultaneously with wheel/rail load<br><br>(Data from concurrent tests at FAST may preclude further detailed studies of fastener strain)   | Dynamic strain and Fastener stiffness<br><br>Load histogram for each combination of site and pad type  | 1a<br><br>4         |
| 7. WHEEL DETECTOR & SPEED    | Six channels for wheel detection<br>Measured distances between detectors  | Train speed, wheel identification  | 1a,b<br>2,3,4       |
| 8. VERTICAL TRACK MODULUS    | Vertical load, applied simultaneously to both rails, and corresponding vertical deflection measured from fixed reference, at a minimum of seven locations in each test section  | Load-deflection plots<br>Mean and variability of track stiffness and modulus   | 1a,b<br>2<br>3<br>4 |
| 9. BALLAST DENSITY (IN-SITU) | Volume of displaced ballast (of water to fill hole) and weight of ballast sample for up to 18 tests:<br><br><ul style="list-style-type: none"> <li>• 6 in ballast crib</li> <li>• 6 under tie at ballast surface</li> <li>• 6 at top of subballast layer</li> </ul> (See Table 5.8-1 for more detailed breakdown) | Variation in density over width and depth of track, to compare with other ballast characteristics  | 1a,b<br>4           |
| 10. PLATE LOAD RESISTANCE    | Applied vertical plate bearing load and corresponding deflection for up to 22 tests:<br><ul style="list-style-type: none"> <li>• 6 in ballast crib</li> <li>• 10 under tie at ballast surface</li> <li>• 6 at top of subballast layer</li> </ul> (See Table 5.8-1 for more detailed breakdown)                    | Variation in ballast stiffness over width and depth of track, to compare with other ballast characteristics                                    | 1a,b<br>4           |
| 11. BALLAST GRADATION        | Weight of ballast sample passing through each of 14 sieves, for 3 to 6 samples per test section   | Cumulative "percent finer than" plots, for ballast classification  | 1<br>4              |
| 12. LATERAL TIE PUSH TEST    | Load vs. deflection of six individual ties in each test section.  | Evelopes of force vs. deflection for all measurements in each section on each visit, range of small deflection stiffness for each test section | 1a<br>1b<br>4       |

(CONTINUED NEXT PAGE)

TABLE 3-3. (CONT.) SUMMARY OF REQUIRED DATA AND DATA REDUCTIONS

MEASUREMENT CYCLES <sup>(1)</sup>

| MEASUREMENT   | REQUIRED DATA   | DATA REDUCTIONS  |  |
|---|---|--|--|
| <p>13. BALLAST &amp; SUBBALLAST MATERIAL PROPERTIES</p> <ul style="list-style-type: none"> <li>a. Liquid &amp; Plastic Limits</li> <li>b. Specific Gravity</li> <li>c. Water Absorption</li> <li>d. Chemical Composition</li> <li>e. Angularity, Sphericity</li> <li>f. Hardness</li> <li>g. Chemical Soundness</li> <li>h. Abrasion</li> </ul> | <p>One complete test series per test section</p>  | <p>Complete tabulated data set</p>   | <p>1</p>   |
| <p>14. SUBGRADE PENETRATION TESTS</p> <ul style="list-style-type: none"> <li>a. Dutch Cone Test</li> <li>b. Standard Penetration Tests (SPT) (Disturbed Samples)</li> <li>c. Material Identification/Stratification</li> </ul>  | <p>(Penetration resistance vs. depth)</p> <p>Tests at intervals of 50 - 100 feet through test section, to depths of 20 - 25 feet</p> <p>Two tests in each section to depths of 20 - 25 feet</p> <p>Visual identification of soil material and strata</p>  | <p>Depth-vs.-penetration force plots, showing mean and range within test section</p> <p>Depth-vs.-penetration force plots, showing mean and range within test section</p> <p>Charts showing stratification vs. depth</p> | <p>P</p>   |
| <p>15. MATERIAL STRESS-STRAIN PROPERTIES</p> <ul style="list-style-type: none"> <li>a. Shear Strength</li> <li>b. Resilient Modulus</li> <li>c. Permanent Strain</li> <li>d. Moisture</li> <li>e. Density</li> </ul>  | <p>Two 4" - 6" diameter borings to depth of 5 - 10 feet, starting at top of subballast layer</p> <p>45 test per track section:</p> <ul style="list-style-type: none"> <li>• 3 test sites</li> <li>• 3 materials (ballast, subballast, subgrade)</li> <li>• 5 samples per material</li> </ul>  | <p>Measured properties tabulated by test site, material and depth. Mean and standard deviation within each material.</p>   | <p>P</p>   |
| <p>16. SUBGRADE PROPERTIES</p> <ul style="list-style-type: none"> <li>a. Water Content</li> <li>b. Unit Weight</li> <li>c. Classification</li> <li>d. Gradation</li> </ul>  | <p>Determined from SPT and tube samples</p>   | <p>Continuous log of property values</p>   | <p>P</p>   |
| <p>17. MOISTURE MONITORING &amp; SAMPLING</p> <ul style="list-style-type: none"> <li>a. Oven samples - Ballast, Subballast and Subgrade</li> <li>b. Moisture Sensors</li> </ul>   | <p>Moisture content of ballast, subballast &amp; subgrade</p> <p>Variety of samples to come from penetration tests, plate load and density tests, ballast gradation tests and samples taken during installation of moisture sensors.</p> <p>Readings of "apparent capacitance" due to moisture variations at intervals of one week for seven sensors per test section: 3 in ballast, 3 in subgrade, 1 extra</p> | <p>Tabulations by depth, material and time of measurement</p> <p>Mean and range of moisture content plotted continuously through test period</p>   | <p>P<br/>1<br/>4<br/><br/>Contin-<br/>uous<br/>P - 4</p> |

(CONTINUED NEXT PAGE)

33

TABLE 3-3. (CONT.) SUMMARY OF REQUIRED DATA AND DATA REDUCTIONS

MEASUREMENT CYCLES <sup>(1)</sup>

| MEASUREMENT   | REQUIRED DATA  | DATA REDUCTIONS  |                     |
|---|--|--|---------------------|
| 18. TRACK GEOMETRY CAR MEASUREMENTS<br>a. Gage<br>b. Alinement<br>c. Profile<br>d. Crosslevel | Standard runs of railroad track geometry car at the same frequency as site visits, with positive identification of beginning and end of test section. It is especially important to have runs before and after maintenance.  | All data reductions normally produced by railroad<br>Strip charts showing all deviations vs. time<br>5-percent level of exceedance of all deviations, plotted vs. MGT                | 1<br>2<br>3<br>4    |
| 19. SURVEY-TO-BENCHMARK<br>a. Vertical<br>b. Lateral<br>c. Longitudinal                       | No. of ties for vertical and lateral measurements: 10 percent at Chessie, 5 percent at other sites<br>Elevation relative to benchmarks, on each field side rail base and adjacent tie surface<br>Lateral position, relative to line established by benchmarks, of near side rail base<br>Longitudinal position of marks on each rail, relative to transverse lines established by benchmarks at three stations | Mean and standard deviation of settlement (change in elevation) vs. MGT.<br>Mean and standard deviation of lateral tie shift vs. MGT<br>Mean and range of longitudinal rail movement | 1a,b<br>2<br>3<br>4 |
| 20. TIE MOVEMENT (SKEW AND SPACING)   | All occurrences of tie skew and spacing deviations exceeding the following levels:<br>a. spacing - $\pm 4''$ and $\pm 8''$<br>b. skew - $\pm 2.25$ degrees and $\pm 4.5$ degrees   | Mean, standard deviation and range of tie skew and tie spacing deviation, plotted vs. MGT  | 1a,b<br>2<br>3<br>4 |
| 21. RAIL CREEP  | Relative longitudinal rail-to-tie movement for both rails in three 20-tie zones  | Mean, standard deviation and range of rail creep, plotted separately for each rail vs. MGT   | 1b<br>2<br>3<br>4   |
| 22. AVERAGE TIE SPACING   | Centerline length of test section and number of ties, for each tie type  | True average tie spacing   | 1b<br>2<br>3,4      |

34

(CONTINUED NEXT PAGE)

TABLE 3-3. (CONT.) SUMMARY OF REQUIRED DATA AND DATA REDUCTIONS

MEASUREMENT CYCLES<sup>(1)</sup>

| MEASUREMENT                                | REQUIRED DATA   | DATA REDUCTIONS   |                  |
|--|---|---|------------------|
| 23. TIE/FASTENER/PAD/INSULATOR INSPECTIONS | Records of tie cracks, tie damage, fastener, pad and insulator movement and fastener, pad and insulator damage<br><br>All tie tops inspected.<br>5 to 10 percent of cribs opened on first and last visits only. | Rates of cracking, damage, movement, fall-out and failure of components plotted cumulatively vs. MGT and vs. distance through test section. | 1<br>2<br>3<br>4 |
| 24. GAGE FACE WEAR                         | Gage face lateral position, relative to the rail web, for both rails at all STB measurement locations   | Mean and standard deviation of gage face wear, plotted separately for each rail vs. MGT   | 1<br>4           |

NOTE (1): DEFINITION OF MEASUREMENT CYCLES

- P = Preliminary site visits to collect subgrade samples
- 1a = First site visit before maintenance
- 1b = First site visit after maintenance
- 2 = Second site visit
- 3 = Third site visit
- 4 = Fourth site visit

#### 4. TEST SITE DESCRIPTION AND INSTRUMENTATION PLAN

##### 4.1 Test Sites

Layouts of the four revenue service test sites are provided in Figures 4-1 through 4-4. Each layout shows the track segments selected for installation of instrumentation and for measurements of track geometry, component condition and ballast/subballast/subgrade properties. In the three concrete tie sites, the instrumentation will be placed either on CC244 ties (Lorraine) or on CC224C ties (Roanoke and Streater). This is required to insure the greatest possible uniformity among the test sections and the best correlation of laboratory and field measurements. Further discussion of each test section, including the Northeast Corridor site, follows.

##### 4.1.1 Chessie Site at Lorraine, Virginia

This is the shortest of the test sections, containing 224 ties at 25-inch spacing on a curve of approximately 3 degrees (Figure 4-1). The instrumentation will be installed on a 100-tie segment of CC244 ties. All other measurements will generally span the entire section, which includes 118 RT-7S ties.

##### 4.1.2 Norfolk & Western Site at Roanoke, Virginia

This tangent site contains 1666 feet of CC244C and RT-72 concrete ties at 24-inch and 26-inch spacings. The site is bisected by a grade crossing which exerts a considerable effect on track geometry. Long-wavelength undulations in surface have been observed emanating from the crossing in the eastbound direction of predominant traffic flow. It would be desirable to isolate the instrumentation from the crossing to the extent possible. But since the CC244C ties are located next to the crossing, the only alternative is to concentrate the instrumentation in the eastern end of the section, perhaps within the last 50 ties. Surfacing maintenance would reduce the effect of surface irregularities initially, but N&W is not planning to perform any maintenance during the test program. Ballast and

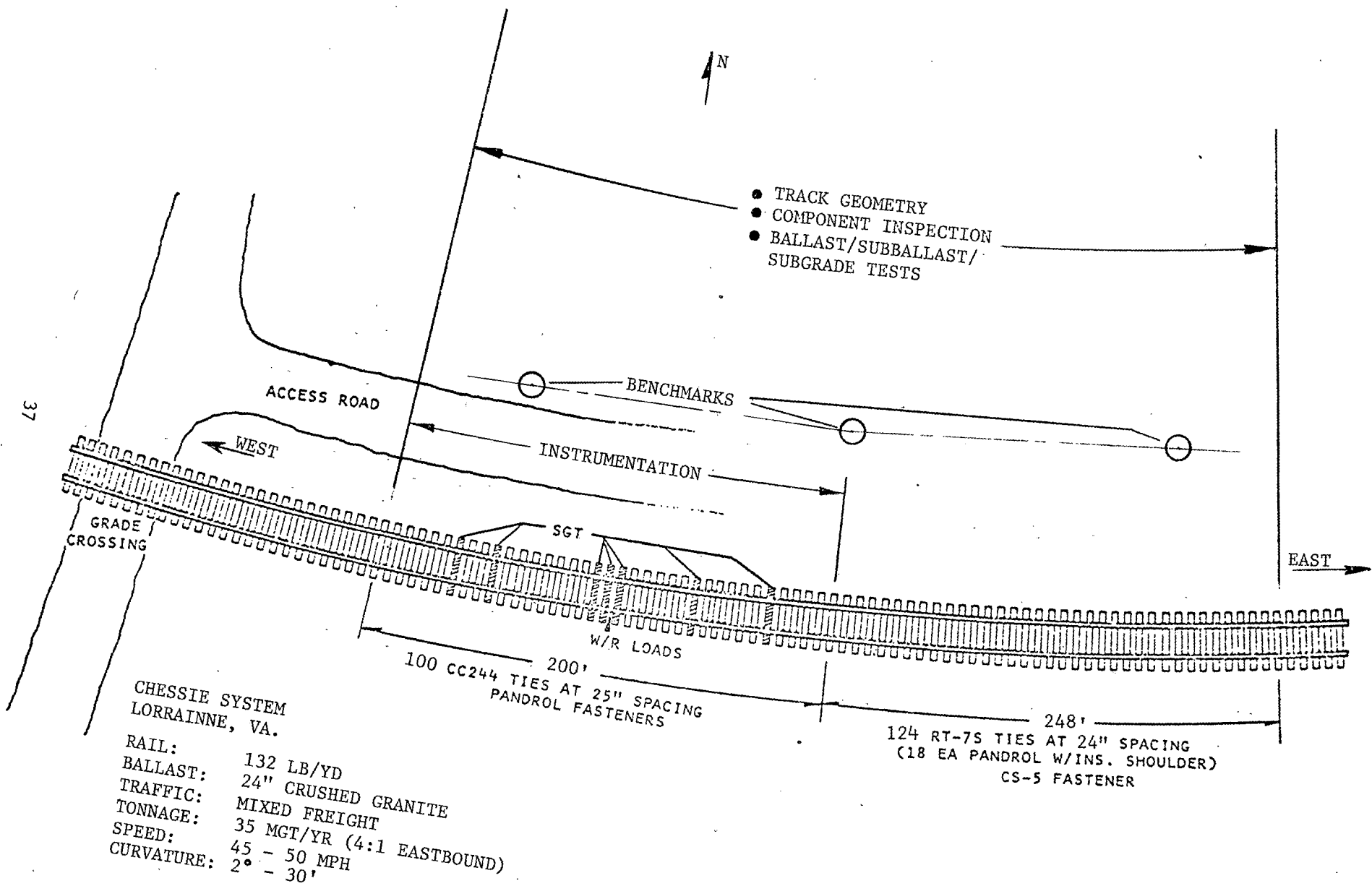
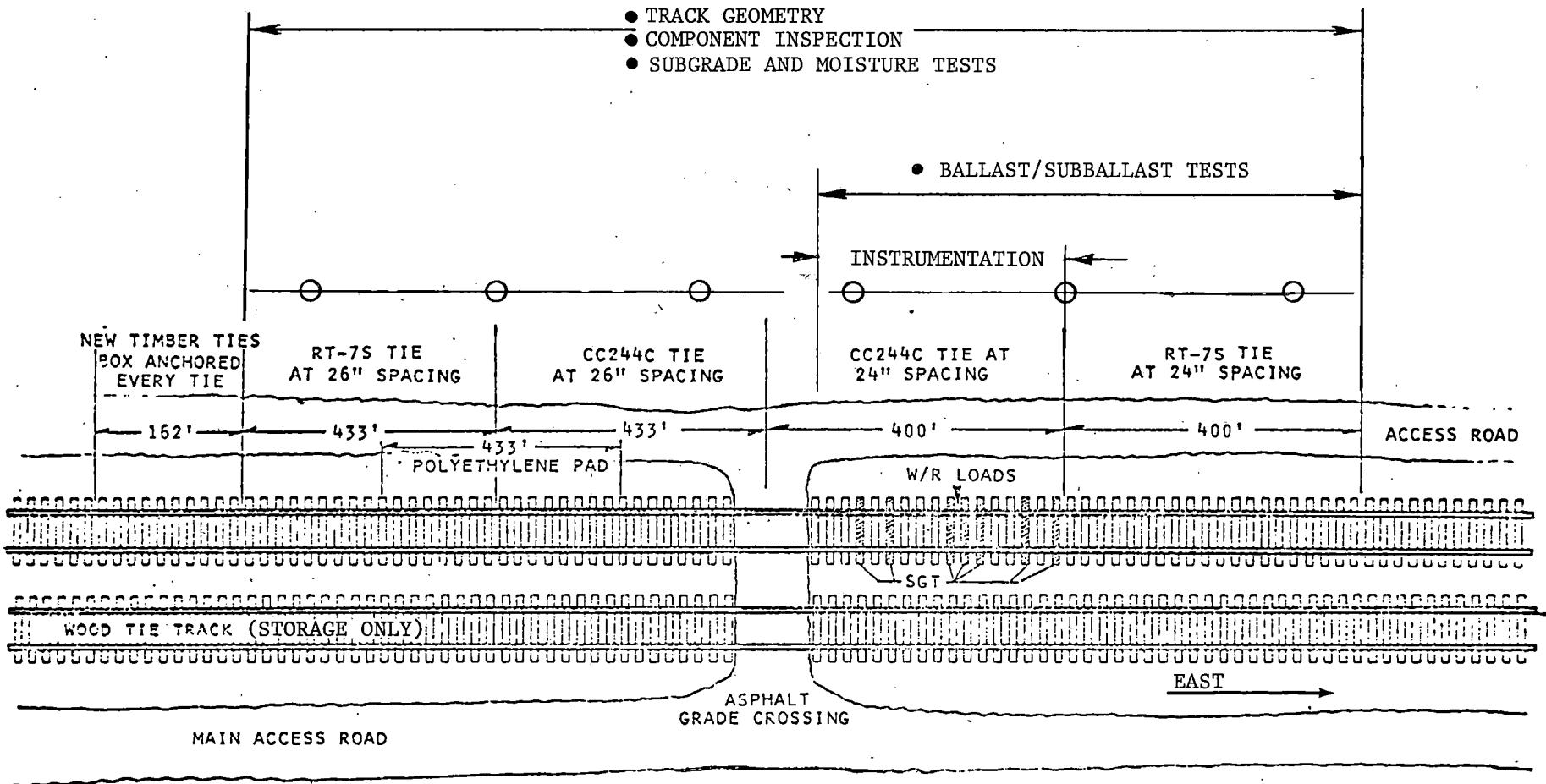

FIGURE 4-1. LAYOUT OF MEASUREMENTS ON CONCRETE TIE TEST SECTION AT LORRAINE, VIRGINIA





|                   |            |   |
|-------------------|------------|---|
| NORFOLK & WESTERN | BALLAST:   | 18" CRUSHED GRANITE                         |
| ROANOKE, VIRGINIA | RAIL SIZE: | 136   |
|                   | TRAFFIC:   | MIXED FREIGHT & UNIT COAL (HEAVY EASTBOUND) |
|                   | TONNAGE:   | 40 - 50 MGT/YR                              |
|                   | FASTENER:  | PANDROL                                     |
|                   | PAD:       | KONVEX (EXCEPT AS NOTED)                    |

FIGURE 4-2. LAYOUT OF MEASUREMENTS ON CONCRETE TIE TEST SECTION AT ROANOKE, VIRGINIA

subballast tests will be carried out in the 800-foot region of 24-inch tie spacing, since most of the ties in the test sections and at FAST have this spacing. However, the track geometry and component condition measurements, subgrade characterization and moisture monitoring will be spread uniformly over the entire section.

#### 4.1.3 Sante Fe Site at Streator, Illinois

This tangent, double-track site contains both the concrete tie section and the wood tie control section (Figures 4-3 and 4-4). The test sections are located on the north track adjacent to the access road. Within the 800-foot concrete tie section, instrumentation will be placed in the 400-foot segment of CC244C ties. All ties are on 24-inch spacing. All other measurements will be distributed uniformly over the entire test section. Comparisons will be made with data collected by PCA over this same test section.

The wood tie control section will be located east of the concrete tie section, separated by at least 100 ties to eliminate the effects of the transition. No instrumentation will be installed on the wood ties except for accelerometers at the rail/tie interface. In addition, one complete set of subgrade characterization and moisture monitoring measurements will be spread evenly over the two test sections. These measurements are expected to remain relatively uniform for the immediate area. Separate and complete sets of track geometry and ballast/subballast tests will be performed in each test section.

#### 4.1.4 Northeast Corridor Site at Aberdeen, Maryland

Aberdeen. The site provides the only significant curvature in the 8-mile segment of concrete ties. The ties are installed on Track 4, the westernmost of 3 tracks at the site. The design speed of the track is 87 mph. For the relatively short period of this test series, a curved site is preferable because it provides a more demanding loading environment than a

N

SANTE FE  
STREATOR, ILLINOIS

RAIL SIZE: 136 CWR  
BALLAST: 24" CRUSHED GRANITE  
TRAFFIC: MIXED FREIGHT & PASSENGER  
TONNAGE: 18 -20 MGT/YR  
SPEED: 79 MPH MAX

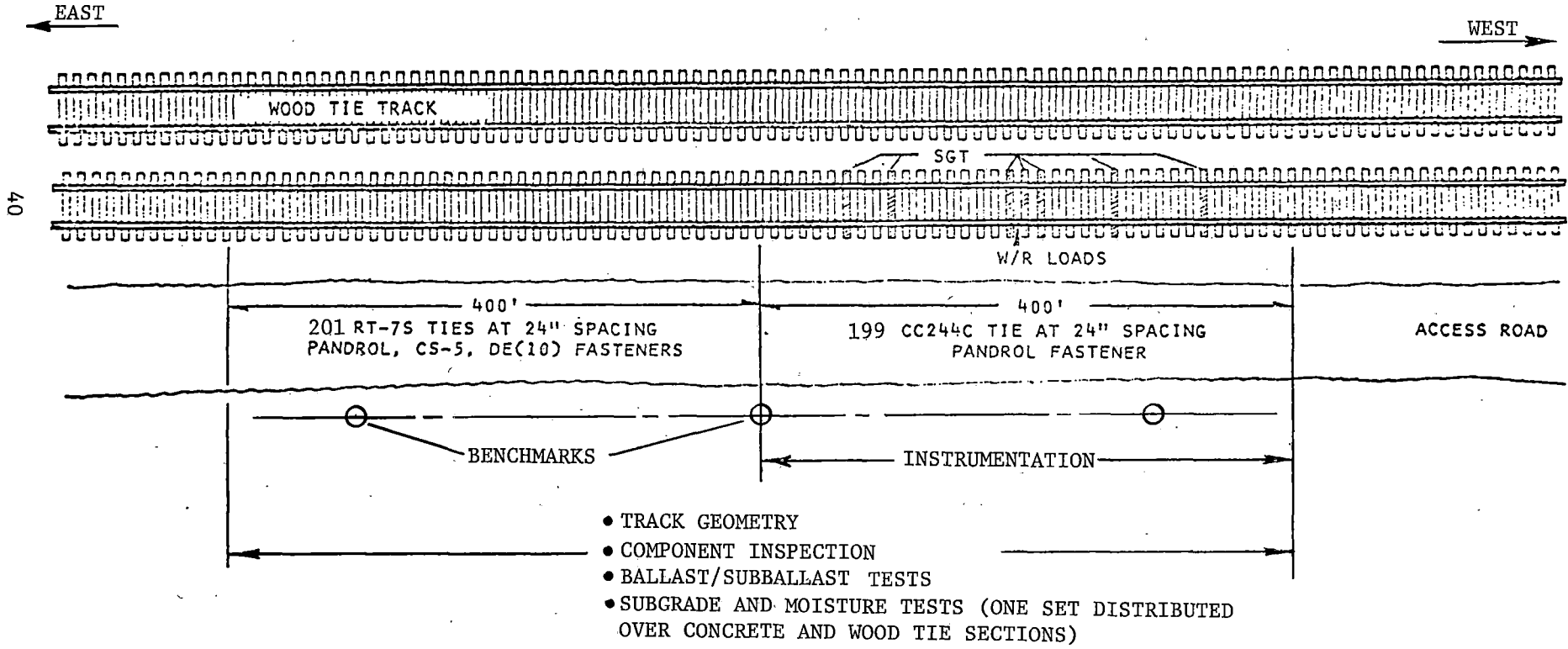

FIGURE 4-3. LAYOUT OF MEASUREMENTS ON CONCRETE TIE TEST SECTION AT STREATOR, ILLINOIS

SANTE FE  
STREATOR, ILLINOIS

BALLAST: 24" CRUSHED GRANITE  
TRAFFIC: MIXED FREIGHT & PASSENGER  
TONNAGE: 18 - 20 MGT/YR  
SPEED: 79 MPH MAX

N

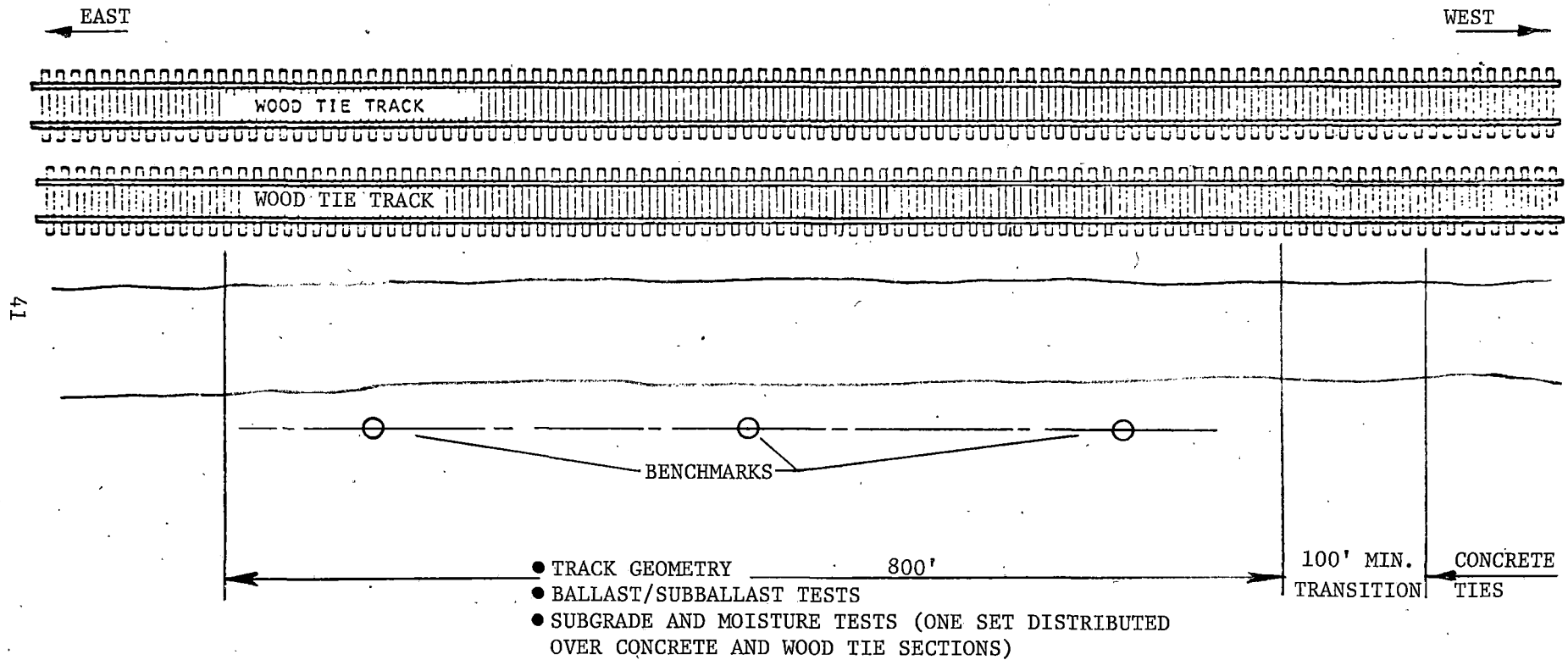

FIGURE 4-4. LAYOUT OF MEASUREMENTS ON WOOD TIE CONTROL SECTION AT STREATOR, ILLINOIS

tangent site. An adjacent section of tangent track will be identified for comparison of failure rates and geometry degradation.

It is planned to define an 800-foot section of the curve as a control section. Component inspections will be made on this segment at the same frequency as the site visits to the revenue service test sections. If possible, the FRA track geometry car should make passes over the track section at the planned measurement frequency.

#### 4.2 Collection of Dynamic Data

Figure 4-5 shows the distribution of wheel detectors, instrumented ties and vertical and lateral load circuits in a typical instrumented section. Additional channels are allotted to clip strain (4) and rail/tie acceleration (2). Six wheel detector sensors will be used independently for each direction of traffic ( $W_1$  or  $W_2$ ), but the recording of wheel detection is the same for either direction. The figure shows the distribution of channels to each of the two multiplex units and to the tape recorder directly. Table 4-1 summarizes the transducer characteristics and required data channels for the dynamic data set.

- ▽<sub>1</sub> = Wheel Detectors, Direction 1
- ▽<sub>2</sub> = Wheel Detectors, Direction 2
- L = Lateral Load Circuit
- V = Vertical Load Circuit
- = Tie Strain
- ▲ = Accelerometer

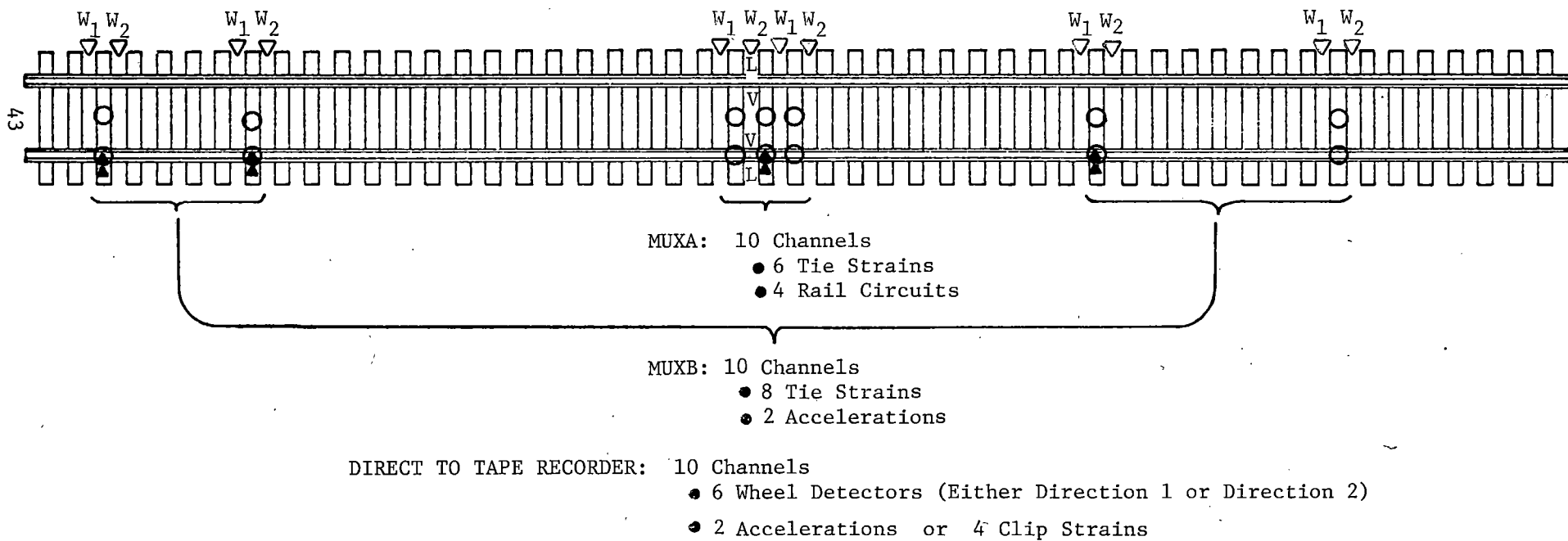

FIGURE 4-5. DISTRIBUTION OF DATA CHANNELS TO MULTIPLEX UNITS AND TAPE RECORDER

TABLE 4-1. DYNAMIC TRACK RESPONSE MEASUREMENTS

| Measurand                   | Transducer                       | Range                | Data<br>Bandwidth, Hz | Locations/Site | Channels |
|-----------------------------|----------------------------------|----------------------|-----------------------|----------------|----------|
| Vertical Wheel/Rail<br>Load | Rail web strain gage<br>pattern  | 75 kips              | 300                   | 2              | 2        |
| Lateral Wheel/Rail<br>Load  | Rail base strain gage<br>pattern | 25 kips              | 300                   | 2              | 2        |
| Tie Strain-Rail Seat        | Strain gage                      | 500 $\mu\epsilon$    | 300                   | 7              | 7        |
| Tie Strain-Tie Center       | Strain gage                      | 500 $\mu\epsilon$    | 300                   | 7              | 7        |
| Rail Acceleration           | Accelerometer                    | 600 g                | 2000                  | 2              | 1        |
| Tie Acceleration            | Accelerometer                    | 60 g                 | 2000                  | 2              | 1        |
| Pandrol Strains             | Strain gage                      | 10,000 $\mu\epsilon$ | 2000                  | *              | 4        |
| Wheel Position              | Wheel detector                   | -                    | -                     | 6              | 6        |
| Time                        | IRIG-B Time Code<br>Generator    | -                    | -                     | 1              | 1        |

\* To be determined

5. INSTRUMENTATION SELECTION, EVALUATION, CALIBRATION,  
INSTALLATION AND OPERATION

Dynamic track response will be determined by measuring the input wheel/rail loads and those track response parameters which can be measured with minimum influence on track performance: tie strain, rail/tie accelerations, and fastener strain.

5.1 Wheel/Rail Loads

(a) Purpose. Vertical and lateral wheel/rail loads will characterize the dynamic loading environment generated by revenue traffic through the test site.

(b) Principle. Strain gage patterns measuring the principal strains in the rail web and rail base will be used to measure vertical and lateral W/R loads, respectively. These gage patterns have been verified from laboratory and field experimental results under Contract No. DOT-TSC-1051. Appropriate gage patterns are illustrated in Figure 5-1.

(c) Accuracy. The desired measurement accuracy is  $\pm 1.5$  kips lateral,  $\pm 2.0$  kips vertical, including system noise, linearity, hysteresis, and cross talk contributions to error.

(d) Equipment. Weldable strain gages, 1-inch length (Ailtech Type SG-129/30 or equivalent) will be used in a quantity of 12 per vertical/lateral measurement site. Due to the required 2 year circuit life, the survival of the Ailtech gage is in question and alternate gages including the Micro-Measurements and Hitec weldables are being considered. The known performance history of the Ailtech gage may still provide a better approach even at the extreme case of replacing all gages prior to each new field data collection period. Equipment for installation includes a capacitive-discharge welder (30 to 100 watt-second range), a rough grinder, a small die grainder, a gage layout marking fixture, a wire stripper, and a terminal crimping tool.

(e) Measurement Locations. See Section 4.

(f) Preparation. Weldable strain gages will be applied according to the manufacturer's recommendations in the User's Manual supplied with the



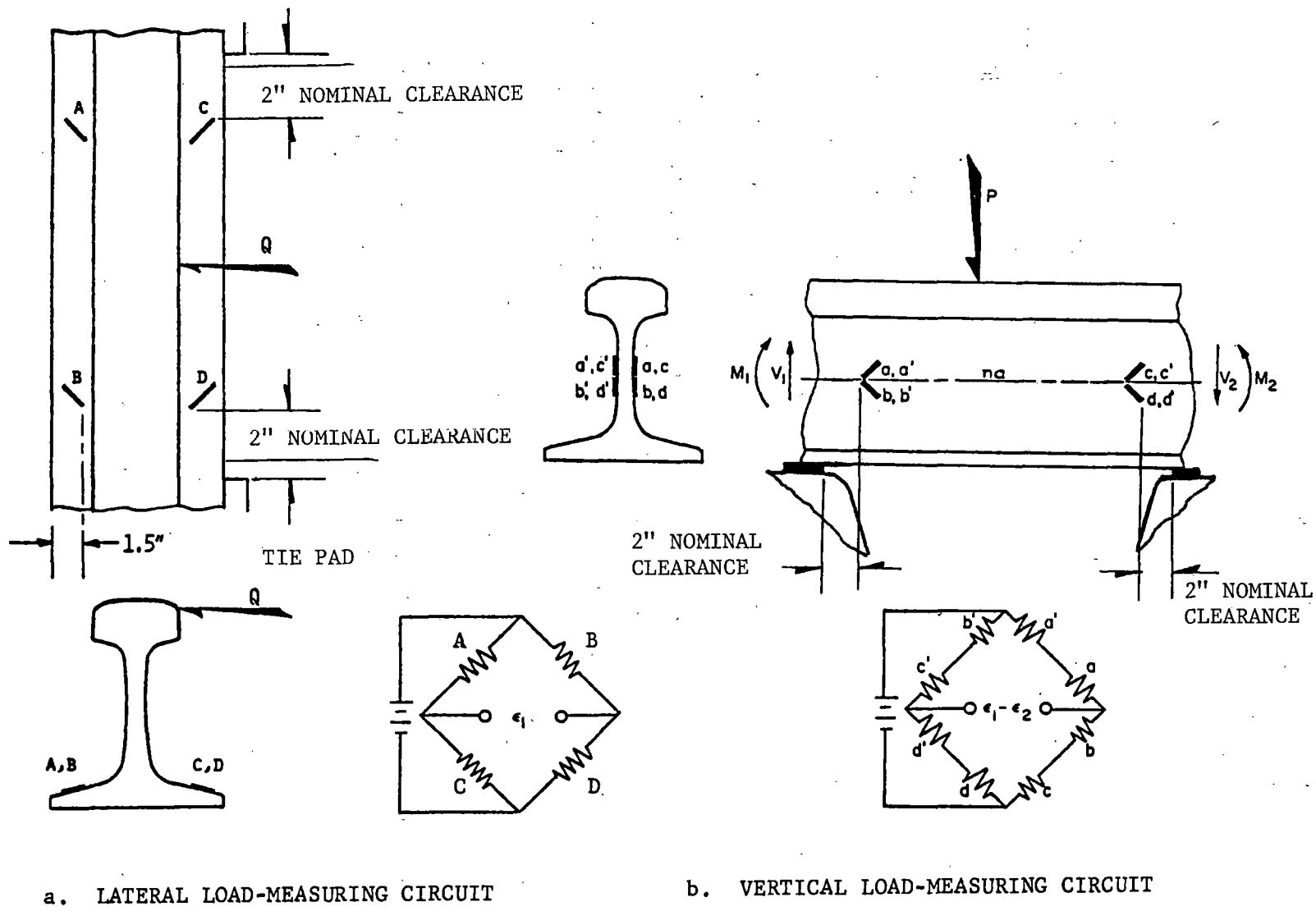

FIGURE 5.1-1. STRAIN GAGE CIRCUITS TO MEASURE LATERAL AND VERTICAL WHEEL/RAIL LOADS, FOR LONG-TERM INSTALLATION ON CONCRETE TIES

gages. A rough grinder will be used to remove all mill scale and pits from the gaged areas of the rail; and following this, the small die grinder will be used to finish the areas directly under and surrounding the gages and strain relief straps. Care must be exercised to maintain the dimensional correspondence of one gage with its counterpart on the opposite side of the rail. Following attachment, each gage will be checked with an ohmmeter for continuity (120 ohm resistance) and isolation from the rail (> 5 megohm from shield to rail) before they are terminated in the bridges of Figure 5.1-1. Two strain relief straps will be used to secure the integral lead strain relief structure. After completion of the gage checkout, a heavy bead of clear, bathtub seal (RTV rubber) will be run over the length of the gage and the strain relief to reduce the effects of rail vibration and to provide some mechanical protection. Gage leads will be terminated within the rail web region or routed through a protective housing to the end of the tie to prevent damage from tampers and dragging equipment.

(g) Instrumentation. Signal conditioning amplifiers will provide a 5-volt excitation to each strain gage bridge. Appropriate cabling and connectors and/or terminal strips will be provided for rapid connection of the instrumentation and recording system for each site visit.

(h) Calibration. A physical, end-to-end calibration is required from each wheel/rail load transducer to the output of the signal conditioning amplifier (SCA). A physical calibration is necessary at the time of installation, at the beginning of each subsequent site visit, and after any repairs are made to the transducer. The calibration is done by applying known lateral and vertical loads to the rail head using laboratory-calibrated load cells, cycling these loads through some reasonable range (0 to 20 kips minimum, lateral, 0 to 30 kips minimum, vertical) while reading the outputs of both the load cell and the gage pattern on an X-Y plotter. Lateral load calibration cycles will be run while under vertical load (15 to 25 kips), with care taken to avoid transverse load paths through the vertical load fixture. After the calibration X-Y plot is run, a bridge shunt calibration (precision resistors across the opposite, active arms of the bridge) will be recorded. The slope of the X-Y plot then provides a determination of SCA output (lb/volt), and the equivalent

value of the shunt calibration. Suggested resistor sizes to achieve a double shunt step approximately 50 percent of the desired full range are as follows:

| <u>W/R Load</u> | <u>Resistor</u> | <u>Full Range</u> |
|-----------------|-----------------|-------------------|
| Vertical        | 301K ohm        | 75,000 lb         |
| Lateral         | 200K ohm        | 25,000 lb         |

SCA gain will then be adjusted so that full-scale output voltage is roughly twice the shunt calibration step voltage, set to some convenient value of volts per kips, or lb per volt.

## 5.2 Tie Bending Strains

(a) Purpose. Strains along the tie longitudinal axis will be used to determine tie bending moments and stresses in response to vertical and lateral wheel/rail loading.

(b) Principle. Longitudinal strain gage coupons will be bonded to one side of the tie at two locations: beneath the rail seat, and at the tie center. From an analytical evaluation of the CC244 tie and from practical considerations of tie damage on the bottom edges, the rail seat gage coupons will be located directly beneath the rail centerline and centered 1.5 inch up from the lower edge of the tie. This will leave about one inch of space to accommodate broken edges. This also coincides with the height of the bottom strands of prestress wire. Resulting strain measurements will be related to tie bending moments by in-situ calibration using the fixture shown in Figure 5.2-1. A series of laboratory tests will be performed to determine the difference in sensitivity indicated using the rail as the center load path and the sensitivity using the AREA recommended loading fixture. Variations in material properties from one batch to another preclude the use of a single sample of ties to determine Young's Modulus. Different amounts of air entrainment from one installation to another is especially significant.

The webbing straps will produce minimal disturbance to the tie support but as an additional precaution, the calibration will be performed just prior to the surface and lining on the Chessie and Sante Fe sites.

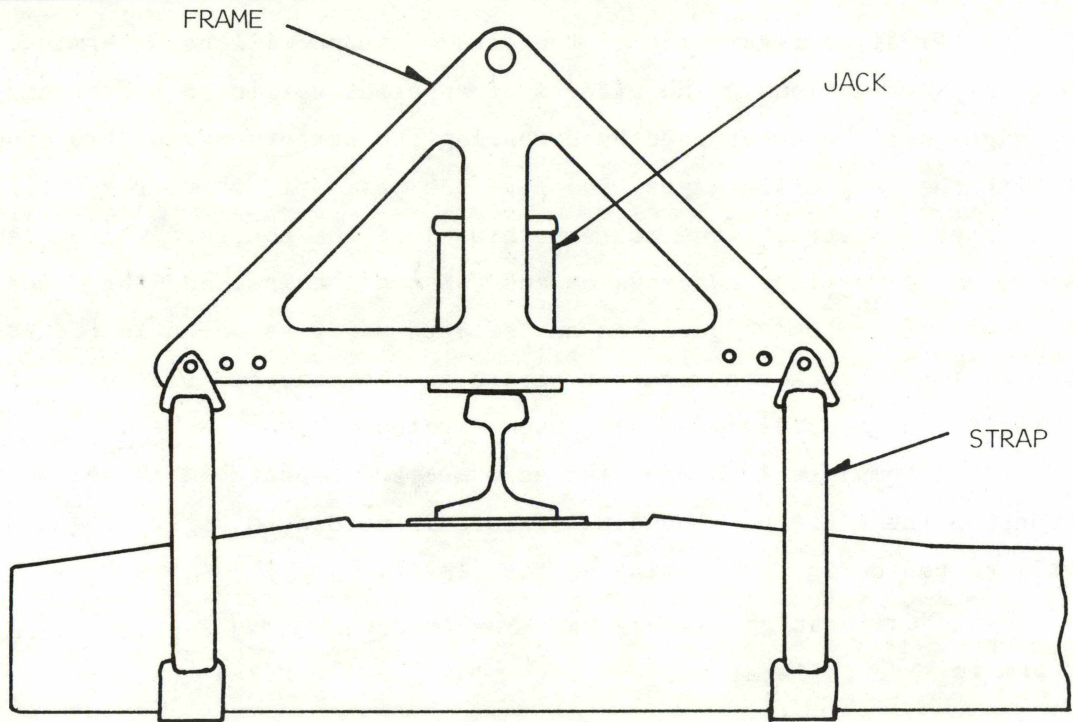

FIGURE 5.2-1. FIXTURE FOR IN-SITU CALIBRATION OF TIE BENDING STRAIN

(c) Accuracy. The desired measurement accuracy is  $\pm 10$  micro-strain ( $\mu\epsilon$ ) due to contributions from circuit noise, gage placement dimensional tolerances, etc.

(d) Equipment. Preassembled, hermetically-sealed strain gage coupons will be used on the concrete ties. These strain coupons, as sketched in Figure 5.2-2, consist of a 4-arm bridge with integral leads, with two parallel 2-inch active gages wired into opposite arms of the bridge, and two shorter temperature-compensating gages completing the bridge.

Final configuration of the strain coupon will be determined during laboratory evaluations. The effects of apparent strain on the bridge completion gages will be determined by comparing the performance of two coupons—one with the completion gages bonded to the base shim where they will respond to the apparent strain (due to temperature) of the concrete while also responding to vertical compression and Poisson strains, and the other coupon will contain completion gages on an isolated wafer as shown in Figure 5.2-2 which will not track the apparent strain in the concrete tie but will also not respond to the compression and Poisson strains.

A template is needed for accurate and repeatable location of strain coupons on the tie, and a bonding fixture is needed to apply adequate pressure to the coupon during the curing of the cement.

A calibration fixture as shown in Figure 5.2-1 will be required to perform in-site calibrations.

(e) Measurement Locations. See Section 4.0.

(f) Preparation. The pressembled strain coupons will be installed on the tie in situ to avoid disturbing the tie seating in the ballast. The surface of the concrete will first be prepared by tapping away any obviously loose or protruding materials, and a careful examination then made for hairline cracks in the concrete greater than about 1/2 inch in length (if such cracks are present, an alternate tie location will be chosen for the site). Strain gage coupons will be applied at the locations sketched below in Figure 5.2-3: An application of AE-10 strain gage epoxy will be made as a preliminary seal to fill all voids. After curing and sanding the epoxied surface flat, a second application of AE-10 will be made to bond the coupon to the tie. A bonding fixture will be used to assure sufficient bonding pressure during the

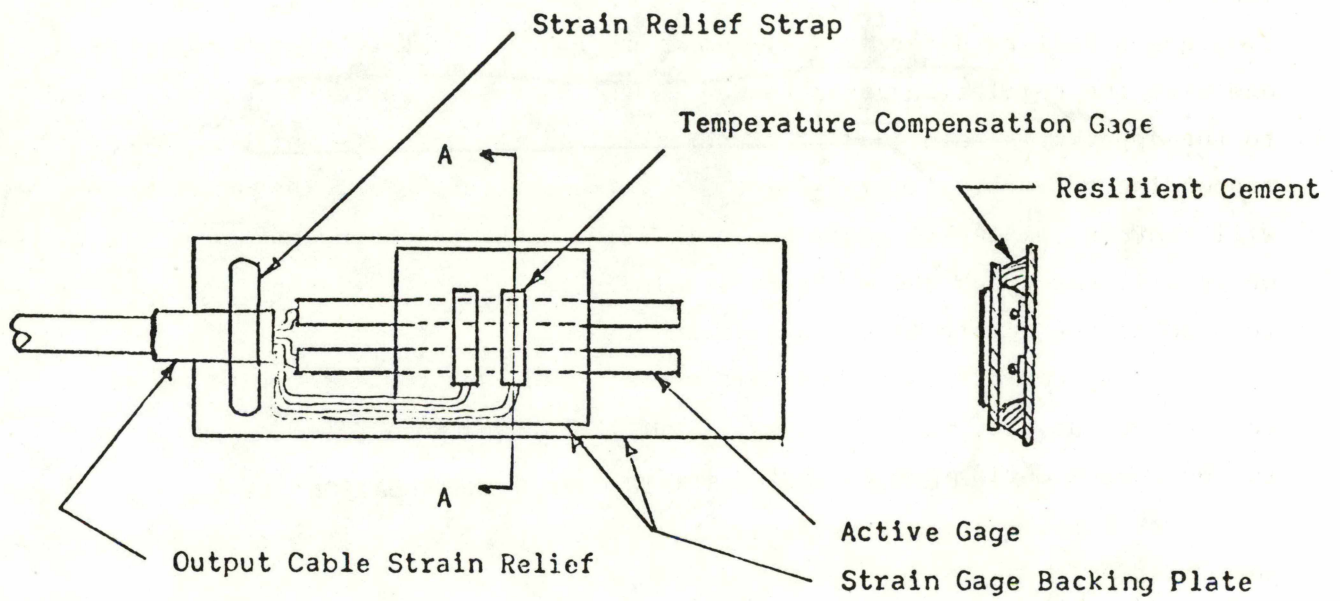

FIGURE 5.2-2. STRAIN GAGE COUPON FOR INSTALLATION ON CONCRETE TIES

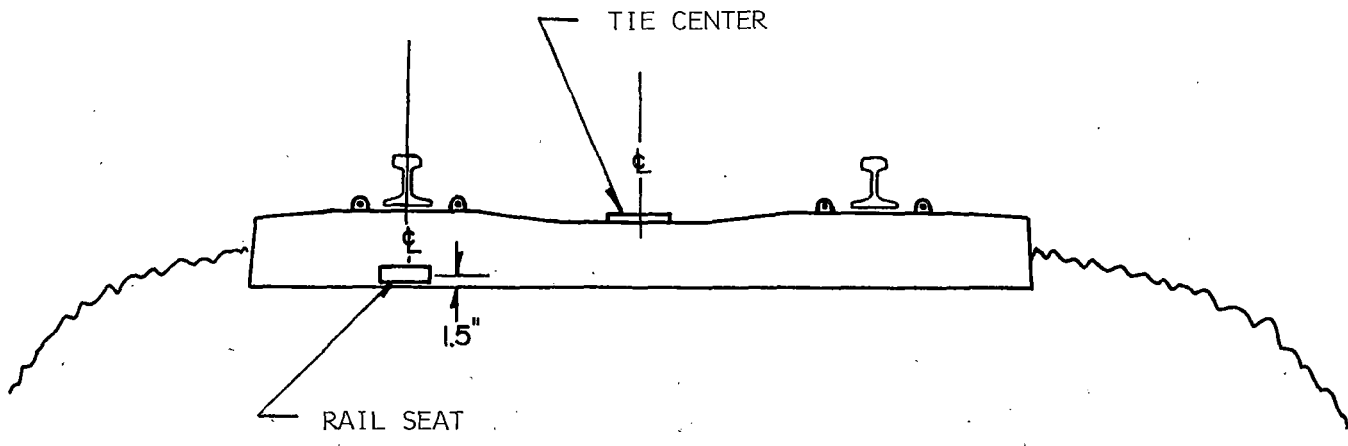

FIGURE 5.2-3. STRAIN COUPON INSTALLATION

cure, and heat lamps will be used to speed the curing if ambient temperatures are below 70°F. Protection of the strain coupon from ballast will be provided by a suitable cover bonded to the tie with a resilient adhesive, such as a bead of RTV rubber. Gage leads will be routed so that track and ballast movement will not cause damage, and additional protection will be provided as necessary to avoid damage from traffic and track maintenance operations.

Durability of this installation technique will be verified by installing two gage coupons at FAST so that they can be subjected to a substantial amount of traffic. The installation at FAST should verify its abrasion resistance as well as any fatigue problems.

(g) Instrumentation. Signal conditioning amplifiers will provide a 5 volt excitation to each strain gage bridge. Appropriate cabling and connectors and/or terminal strips will be provided for rapid connection of the instrumentation and recording system.

(h) Calibration. Resistor shunt calibration across the two active arms of the bridge will be used in the field to determine strain gage output in microstrain per volt at the signal conditioning amplifier. Precision resistor sizes will be determined for the strain coupons based on laboratory tests to provide a step change in output roughly 50 percent of full scale. The strain gage bridge output is based on the relationship:

$$e/V = (\text{gage factor}) \times \frac{(\text{active arms})}{4} (\epsilon)$$

where:

e = voltage out

V = excitation voltage

$\epsilon$  = strain (in/in)

so that:

$$\epsilon = \frac{2 \times \Delta e}{(\text{SCA Gain}) \times (\text{gage factor}) \times V}, \text{ calibration step equivalent strain}$$

where  $\Delta e$  = change in output voltage by shunt calibration,

(SCA Gain) = amplifier gain setting.

The effects of long cable lengths between the gages and the SCA (greater than about 50 ft) will be determined by means of a precision calibrator, and the strain equivalent of the shunt calibration step adjusted accordingly.



### 5.3 Rail and Tie Accelerations

(a) Purpose. Measurements of vertical accelerations of the rail and the tie in the vicinity of the rail seat will characterize the transfer function between rail and tie through the pad/fastener combination, as well as define the vibrational environment of these two track components under revenue traffic. The effect of rail corrugations, if present, is of particular interest.

(b) Principle. Accelerometers for measuring vertical accelerations will be mounted to the rail base and to the tie top surface as close as possible to the rail seat area. These two simultaneous signals will be analyzed by Fast Fourier Transform (FFT) techniques to determine the transfer function between rail and tie, as well as the power spectral density, amplitude and phase spectra of the individual signals.

(c) Accuracy. The desired measurement accuracy is  $\pm 5$  g on the rail acceleration, and  $\pm 1$  g on the tie accelerations, based on the following range and bandwidth:

| <u>Measurement</u>         | <u>Full-Scale Range</u> | <u>Minimum Data Bandwidth, Hz</u> | <u>Channels Per Site</u> |
|----------------------------|-------------------------|-----------------------------------|--------------------------|
| Rail Vertical Acceleration | $\pm 500$ g             | 2000                              | 1                        |
| Tie Vertical               | $\pm 50$ g              | 2000                              | 3                        |

(d) Equipment. Accelerometers with the required amplitude and frequency range given above will be required, plus appropriate signal conditioning amplifiers and special leads or cabling as required. As a minimum, a 4-channel FM magnetic tape recorder is recommended for permanent recording, and an oscilloscope and/or light-beam oscillograph for on-site data quality control.

(e) Measurement Locations. See Section 4.0. However, in addition to general location requirements, specific tie locations will be chosen to be as near as possible to any kind of rail running surface anomaly (rail joint, dipped weld, wheel burn, corrugation, etc.) to provide the highest W/R load input for a good "signal to noise" ratio. Locations will be marked and logged by tie number.

(f) Preparation. Small phenolic blocks (about 1" square) will be used for mounting the particular accelerometers to the tie or rail. A number of these can be made up in the shop and mounted at the chosen tie locations. Blocks for the rail base will be tapered on the bottom surface to the angle of the base so that the accelerometer, when mounted, will be perpendicular to the plane of the track. On the rail base, a patch will be ground to remove dirt and mill scale, as close as practical on the gage side to the centerline intersections of rail and tie. The block will be mounted with quick-setting epoxy cement and held by c-clamp until cured. For installation on the top of the tie, a patch will be cleaned as close as practical to the tie centerline and the edge of the rail base on the gage side, and a layer of epoxy cement laid down as a surface filler. After this has cured, the block will be mounted with additional quick-setting epoxy cement and held under pressure until cured.

(g) Calibration. Accelerometers and associated amplifiers will be calibrated prior to each day of measurements using a standard laboratory calibrator, such as the General Radio Model 1557A calibrator, which provides an excitation of 1 g rms at 100 Hz.

#### 5.4 Fastener Strain

Fastener strain will be evaluated in depth at FAST under contract DOT-TSC-1595. It is anticipated that little or no additional information will be required during the field testing for this program. However, strain gaged clips may be available from the other test program to provide correlation with FAST results with a minimum of additional effort on this program. Data system capacity will not be affected by this measurement because it can be used alternately ("time shared") with the acceleration measurements. It is likely that the major interest will be in comparison of dynamic clip strains when installed on pads with different stiffnesses.

## 5.5 Wheel Detection and Train Speed

(a) Purpose. Wheel detector pulses from each independent measurement location will be required for statistical processing of data and determination of train speed. An example of the wheel detector pulse with relation to typical W/R load measurements is shown in Figure 5.5-1.

(b) Principle. Standard electromagnetic wheel detector transducers positioned at the measurement locations will provide an electrical pulse that will be used in the data processing sequence. Each wheel passing the transducer will generate the raw pulse which is then conditioned for recording by the circuit of Figure 5.5-2. The recorded pulse will later be used to generate a timed pulse to enclose the data generated by that wheel through the measurement zone.

(c) Accuracy. The pulse accuracy desired is defined by a zero crossing (change in polarity) within  $\pm 1$  inch of the center-line of the transducer body.

(d) Equipment. Twelve wheel detector transducers (Servo Corporation Model 400022-16) and wheel detector clamps (Model 200114-01), or equivalent are required, along with six conditioning circuits (Figure 5.5-2) and associated cabling, in each of the two test sections.

(e) Measurement Locations. The transducers will be placed on the rail in the crib area on either side of each single instrumented tie and in all 4 cribs at the 3-tie primary location as shown in Figure 4-5.

(f) Preparation. Wheel detector transducers will be attached at the locations noted in (e) using the associated clamps. No preparation of the rail is required, other than cleaning off excess dirt and grease.

(h) Calibration. Transducers will be checked out at the conditioning circuit output by passing a hammer or spike maul over the transducer to determine if a sufficiently high voltage pulse for recording purposes is generated.

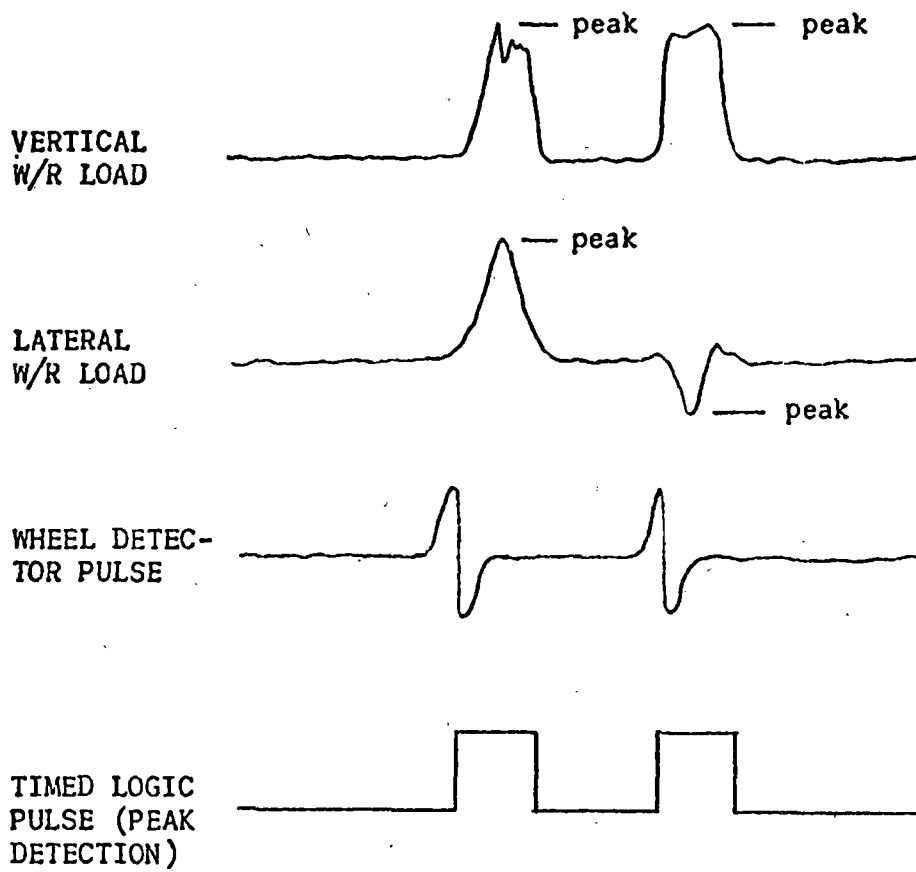

FIGURE 5.5-1. EXAMPLE OF USE OF WHEEL DETECTOR TRANSDUCER TO PROVIDE WAYSIDE DATA PEAK DETECTION AND A/D CONVERSION IN DATA PROCESSING

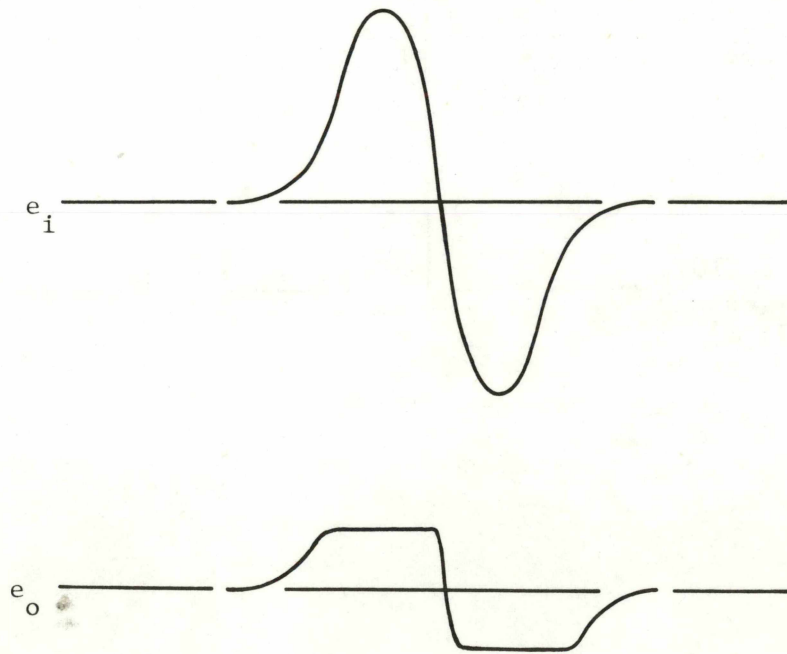
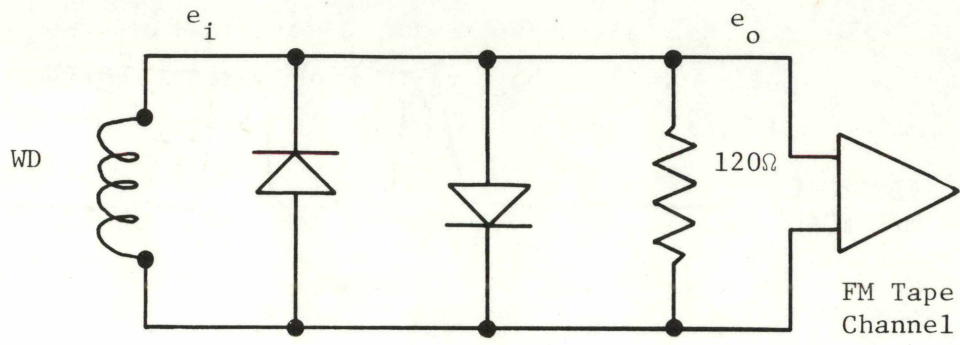

FIGURE 5.5-2. WHEEL DETECTOR TRANSDUCER SIGNAL CONDITIONING

## 5.6 Vertical Track Modulus

Because concrete tie track has a relatively high modulus, it is recommended that an optical instrument such as a surveyor's theodolite be mounted at least twenty feet from the rail to resolve the relatively small vertical deflection of the rail under load. A point load of known magnitude will be applied simultaneously to both rails using vertical hydraulic jacks reacting against a loaded freight car. Deflection readings will be made at a minimum of three loads (e.g., 10, 20, 30 kips) at each of the tie locations discussed in Section 3.3.1. Track modulus will be calculated using the expression:

$$u = \frac{1}{4} \left( \frac{k_r}{EI} \right)^{1/3}$$

where

$u$  = track modulus - lb/in/in,  $k_r$  =  $\Delta P/\Delta Y$  from the measurements.

## 5.7 Field Inspection of Ballast and Subgrade Conditions

### 5.7.1 Introduction

As a part of the overall field inspection of track conditions, ballast and subgrade conditions will be inspected visually during each site visit. The objectives of this visual inspection are to document the general condition of the ballast and subgrade layers and their changes with track history, and to identify any significant problems in the ballast and subgrade layers that may influence behavior of other track components and track performance. Carefully executed visual inspection will aid in accurate characterization of in-situ ballast and subgrade conditions, in proper interpretation of various proposed measurements, and in meaningful correlation between the measurements and track performance.

### 5.7.2 Scope

A total of 4 series of visual inspections will be made at each test site, at an interval of approximately six months. The first and fourth inspections will be made simultaneously with the ballast physical state tests.

These visual field inspections will be performed by an experienced University of Massachusetts geotechnical staff member. Emphasis will be given to the description of the ballast profile, ballast degradation and fouling, drainage, and subgrade conditions. However, general information on the site conditions, the relevant area geology, and seasonal variation of climate conditions will also be gathered. Photographic documentation of ballast conditions will be made during each site visit, so that a continuous and systematic comparison of the ballast condition changes can be made with track history.

The results from the field site inspection will be compiled into a series of field inspection reports.

### 5.7.3 Information Needed

The following lists the information to be gathered during the visual inspection of ballast conditions:

1. Ballast Conditions.

- a. Profile: mean and variation of ballast depth and shoulder dimension over the test section.
- b. Displacement and/or dislocation: caused by traffic induced loads, track maintenance work, and lateral, longitudinal, and/or vertical dislocation of tie.
- c. Degradation of ballast particles: caused by wear, abrasion, or crushing.
- d. Ballast fouling:
  - 1) Infiltration of fines from outside the track
  - 2) Pumping from subgrade
  - 3) Abraded fines
  - 4) Spillage
  - 5) Coal dust
  - 6) Vegetation.
- e. Drainage conditions: presence of moisture and/or water pockets.
- f. Degree of ballast densification.

2. Subgrade Conditions

- a. Drainage
- b. Pumping
- c. Instability
- d. Ballast intermingling.

The following information will be provided by the subcontracting railroad.

- 1. General Site Conditions. This information will be gathered prior to or during the first site visit. Items a, b, c and d are needed for correlation with ballast and subgrade conditions and will be the responsibility of BCL.
  - (a) Name of subcontracting railroad
  - (b) Geographical site location including mile post or appropriate test section number
  - (c) Track description including track type, FRA classification, type and magnitude of traffic, and train speed



- (d) Track super structure: rail weight and type, joints, fastener type, rail anchorage, tie type, and dimension, including manufacturer's name and model number .

2. Track History.

- (a) Maintenance work: type and scope of maintenance done prior to and/or between site visits, type of machine used, maintenance procedures used
- (b) Traffic history: type, tonnage, etc.
- (c) Climate record: weather, precipitation, temperature, etc.
- (d) Other significant events that have occurred at the test site prior to and/or between site visits
- (e) Ballast and subballast: type, specified characteristics including gradation, shape, relative hardness, origin and supplier, specified ballast depth and shoulder width
- (f) Subgrade: soil type and conditions .

5.8 Ballast Physical State Tests

5.8.1 Introduction

The objectives of this series of tests are to determine the ballast physical states at the beginning of the testing program, and to evaluate subsequent changes from maintenance operations and traffic. Determination of in-situ ballast physical states with track history, along with visual inspection of field track conditions, will provide basic information needed for identifying important track parameters influencing track responses and their correlation to track performance.

The measurements planned for the ballast physical state determination include (a) in-situ ballast density, (b) plate load resistance, and (c) lateral tie push resistance. In-situ ballast density is measured by determining the volume and weight of ballast samples, carefully excavated without disturbing in-place structure of ballast and subgrade layers. A special method for measuring in-situ ballast density has recently been developed,

and this is described schematically in Figure 5.8-1 (Reference 1). The basic concept is that of the water replacement method, which has been widely used in the highway and embankment constructions.

The plate load test measures vertical ballast and/or subgrade stiffness under applied load. The test will be accomplished by applying static loads to a small size (5-inch diameter) plate and measuring the resulting deflection. Often, the measurements are also taken during subsequent unloading to determine the rebound characteristics. The test is a direct measure of ballast physical state and load-deformation characteristics. Figure 5.8-2 shows a schematic illustration of the plate load test apparatus.

The lateral tie push test is a common field method of measurement related to track performance used in the railroad industry. It measures lateral tie resistance to displacement under unloaded rail conditions. The test is only an indirect measure of ballast physical state, but it is directly relevant to the lateral track restraint. Figure 5.8-3 describes a device for measuring the resistance of a single tie to lateral force.

Detailed description of these tests can be found in Reference 1.

### 5.8.2 Scope of Tests

The ballast physical state tests will consist of three series of measurements at four test sections, including the wood tie control section. The first and second series will be conducted before and after tamping during the first site visit. The third series will be done during the last (fourth) visit after the accumulation of about 2 years of traffic.

During each series, each test section will be subjected to 18 ballast density tests (BDT), 22 plate load tests (PLT), and 6 lateral tie push tests (LTPT). Six or more ties per test section are needed to be unfastened for the lateral tie push tests. Among the 6 randomly selected, nonconsecutive ties used for the LTPT's, 4 ties will be completely removed for the under-tie ballast density and plate load tests, i.e., two ties each. Two cribs near the removed ties will also be involved in each of the tests.

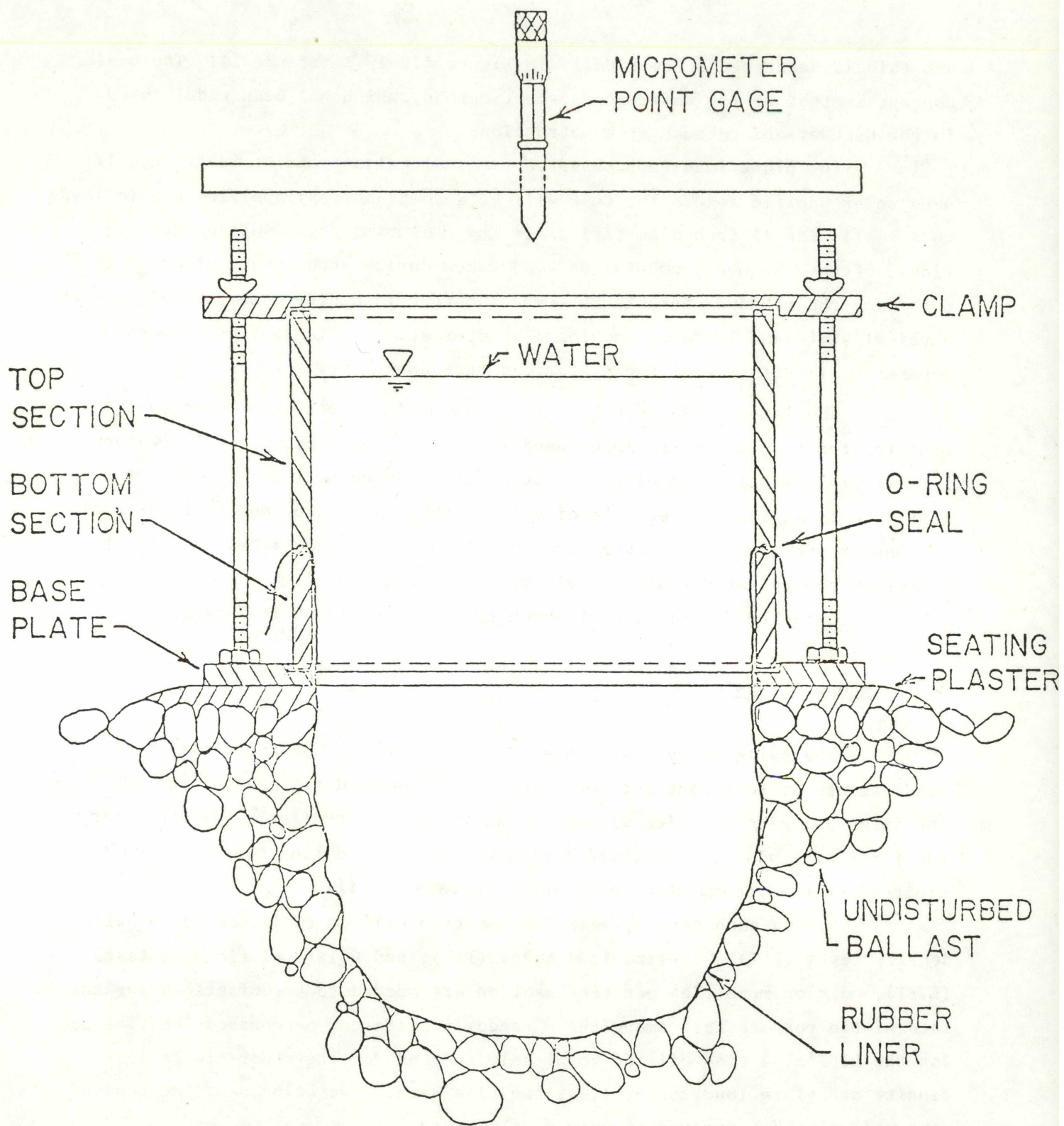

FIGURE 5.8-1. SCHEMATIC ILLUSTRATION OF IN-SITU BALLAST DENSITY APPARATUS

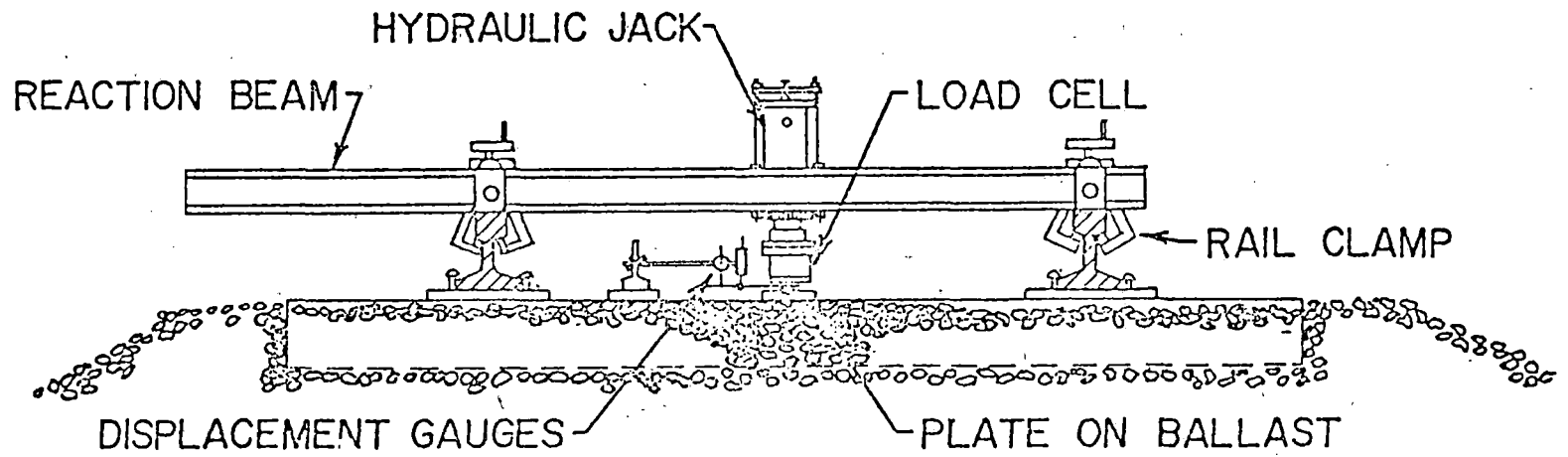

FIGURE 5.8-2. SCHEMATIC ILLUSTRATION OF PLATE LOAD TEST APPARATUS

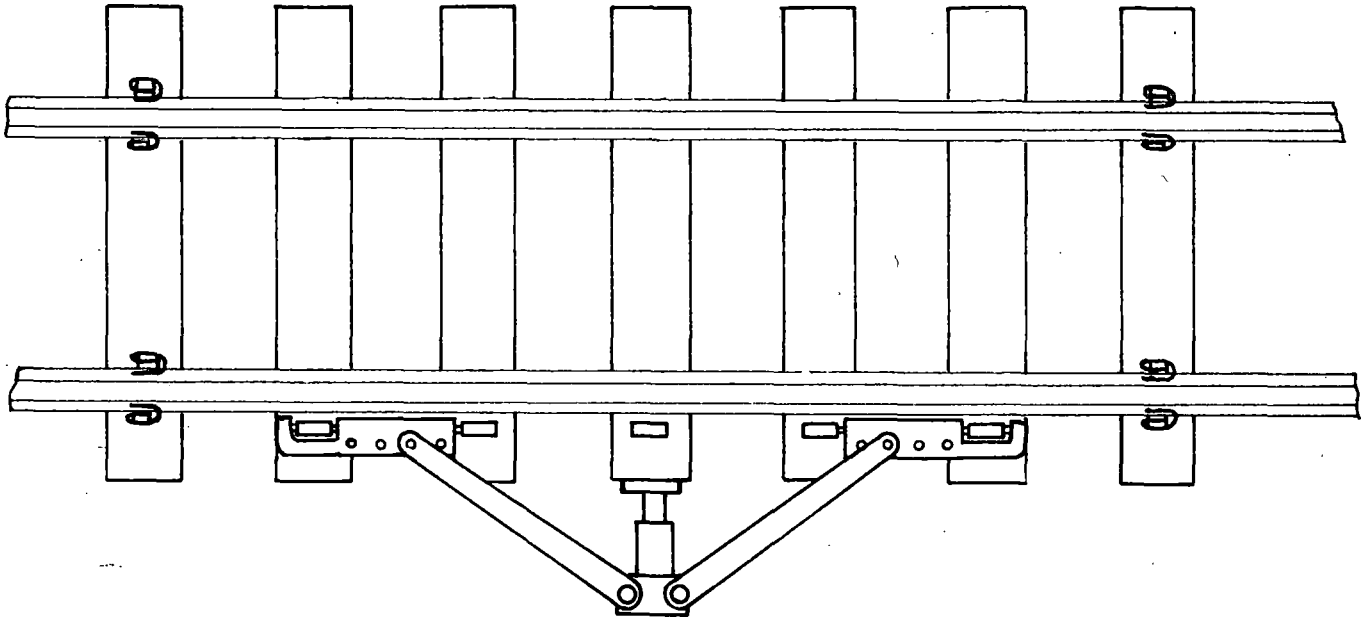

FIGURE 5.8-3. SCHEMATIC ILLUSTRATION OF LATERAL TIE PUSH TEST APPARATUS

The ballast density tests and the plate load tests will be conducted in a group at nearby ties so that comparison of results from the two tests can be made under similar conditions. First, 6 BDT's and 6 PLT's will be conducted on the crib surface. Next, under the 4 ties, at the tie/ballast interface, 6 locations will be randomly selected for BDT's. From past experience with data variability, it is estimated that at least 6 tests with similar conditions are needed to make any valid statistical inferences. The BDT locations will be directly adjacent to the rail on either the inside or outside because these locations are most comparable. There will be no BDT's done in the center of the track under the tie in order to increase the number of replicate measurements to 6 under the rail. Six locations under these 4 ties will also be selected randomly for PLT's. These PLT's will also be performed under the inside and outside of the rail. In order to check for any center-binding effects, 4 additional PLT's will be performed in the center of the track under the 4 removed ties.

Another set of PLT's and BDT's are designated for a lower depth in the ballast layer. Unless the cone penetrometer tests show that the ballast/subgrade interface is less than 18 inches below the tie, this second set of tests will be performed at 12 inches below the tie. A 12-inch depth represents a practical limit for excavation due to size of the excavation required. If all sites have a ballast depth of more than 18 inches, this will provide a consistent set of data which can be directly compared.

Table 5.8-1 summarizes the type and number of the above described tests to be performed during each series at each site. The proposed number of each test represents the minimum needed to ensure a reasonable level of statistical confidence of the results. The total number of tests will be 192 BDT's, 240 PLT's, and 72 LTPT's. However, if time will not permit completion of all of these tests, then some will be eliminated in the order of: (1) BDT's in the crib, (2) BDT's at the lower depth, and (3) PLT's at the lower depth.

TABLE 5.8-1. REQUIRED PHYSICAL STATE TESTS

---



---

Series I (before maintenance):

LTPT - 6 total  
 PLT - 6 in crib  
     10 under tie ( 6 under rail, 4 in track center)  
     6 at 12 inch depth (6 under rail)  
     22 total

BDT - 6 in crib  
     6 under tie (under rails)  
     6 at 12 inch depth (under rails)  
     18 total

Series II (after maintenance)

LTPT - 6 total  
 PLT - 6 in crib  
     10 under tie (6 under rail, 4 in track center)  
     0 at 12 inch depth  
     16 total

BDT - 6 in crib  
     6 under tie  
     0 at 12 inch depth  
     12 total

Series III (after traffic)

LTPT - 6 total  
 PLT - 6 in crib  
     10 under tie (6 under rail, 4 in track center)  
     6 at 12 inch depth (6 under rail)  
     22 total

BDT - 6 in crib  
     6 under tie (under rails)  
     6 at 12 inch depth (under rails)  
     18 total

Total Tests

LTPT: 6 tests/series x 3 series/site x 4 sites = 72 tests

PLT: (22 + 16 + 22) test/site x 4 sites = 240 tests

BDT: (18 + 12 + 18) tests/site x 4 sites = 192 tests

---



---

In addition to these tests, gradation tests and moisture content tests will be conducted based on material collected at 18 ballast density sampling locations, and also at 3 moisture sensor locations. A series of reference density tests will also be performed at each test section.

### 5.8.3 Test Layout

Figure 5.8-4 shows a typical layout of the proposed ballast physical state tests. It also indicates locations for moisture sensor installation. The layout represents only one series of the three test series. All of the ties to be used for the LTPT's will be selected at random within a given section of the test site. The test locations for BDT's and PLT's will be selected at random for the locations under the 4 ties used for the LTPT. A similar layout will be used for each of the test series. Since disturbance to the instrumented ties is not desirable, the ties to be selected for the tests will be at least 20 ties away from those instrumented ties. Also, test layouts should be isolated from the extreme ends by at least 20 ties.

In the proposed layout, the distribution of each test for each different track condition (i.e., different series) is made in such a way that representative testing and/or sampling locations can be obtained, and possible effects of ballast disturbance during successive series of tests can be avoided. Slight modification from the above described general layout will, of course, be made when any designated ties or crib areas are not suitable for testing. For example, a very narrow or only partially filled crib may not be suitable for the BDT and PLT, and skewed or damaged ties are unacceptable for the LTPT.

It is desirable to inspect all the ties and cribs to be involved in the tests at the beginning and to make any possible adjustments in advance. Once ties have been selected for the entire series of tests, they should be marked appropriately, and should be reserved for the specified tests. These ties should not be subjected to any tests accompanying track disturbance.

### 5.8.4 Test Procedures and Apparatus

Table 5.8-2 lists test apparatus and equipment required for the ballast physical state tests. Further detailed descriptions of the test apparatus and



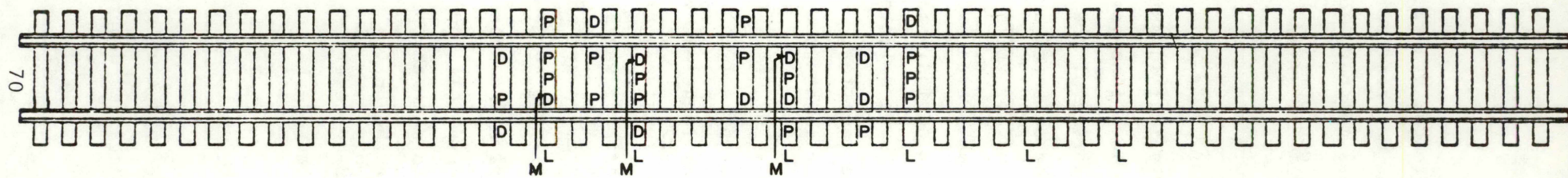

NOTE: ● 6 RANDOMLY SELECTED TIES

● BDT & PLT LOCATIONS RANDOMLY  
SELECTED WITH EQUAL NUMBER  
UNDER EACH RAIL

L - LTPT LOCATION

P - PLT LOCATION

D - BDT LOCATION

M - MOISTURE SENSOR LOCATION

FIGURE 5.8-4. TYPICAL LAYOUT OF PHYSICAL STATE TESTS IN BALLAST

TABLE 5.8-2. REQUIRED TEST APPARATUS AND EQUIPMENT

- 
- 
1. Ballast density devices and accessories.
  2. Reference density test device and accessories.
  3. Plate load test apparatus and accessories.
  4. Lateral tie push test apparatus and accessories.
  5. X-Y recorder for items 3 and 4.
  6. Power generator.
  7. Track carts.
  8. One set of heavy-duty balance with weights, 20 kg. capacity, 1 gm. sensitivity.
  9. One set of 12-in.-diameter sieves: 2 in., 1-1/2 in., 1-in., 3/4-in., 1/2 in., 3/8 in., #4, #10, #20, #40, #60 (or #70), #100, #200, pan and #200 washing sieve.
  10. Sieve shaker for item 9.
  11. Drying oven.
  12. Two to four mixing pans, 2 ft x 2 ft size.
  13. Two to three water containers, at least 5 gal. capacity.
  14. 200 to 400 lb plaster of Paris.
  15. Sample bags, plastic lined cloth, medium size.
  16. Miscellaneous soils lab tools.
  17. Tools to remove and replace ties and ballast.
  18. Sand cone density apparatus.
- 
-

test procedures are contained in Appendices A to D. Data reduction procedures are also briefly described in the test procedures in the appendices. For general description of test site conditions to be obtained during the tests, general guidelines for visual inspection should be followed.

#### 5.8.5 Test Schedule

Field crew for the ballast physical tests will consist of 1 supervisor, 2 persons for BDT, and 2 persons for LTPT/PLT. With this level of staffing, the track time required to perform the tests is about 3 days for each track condition, assuming that the track would be accessible and closed to train traffic for two separate five hour intervals. One to two additional days are also needed for on-site preparation, sample collection, and other related activities.

Since so many activities are scheduled during the first site visit, careful scheduling and coordination are mandatory among various groups of persons involved. The sequence of various tests is also important because of usually limited track time and space. A detailed schedule will be arranged in advance, with consultation among BCL, the subcontracting railroads, and the University of Massachusetts.

#### 5.8.6 Additional Sampling

In addition to sampling for gradation and moisture content at the BDT locations and moisture sensor locations, a quantity of ballast samples is needed for ballast reference density test, index property tests, and repeated load triaxial tests. Sampling for these tests will be done after the first series of ballast physical state tests and prior to the track maintenance during the first site visit.

To minimize disturbance to the track, the additional material sampling will be done as much as possible at those ties assigned for the ballast physical state tests.

Additional samples will be taken under the plate load tests at both elevations to insure an adequate supply to perform the laboratory tests. When excavating for the subballast tests, a continuous log will be kept and samples will be taken down to the depth where the sampling from the subsurface investigation began. This will provide a continuous characterization of the supporting soil.

Figure 5.8-5 shows a representative cross section of track with typical measurements and samples to be taken.

A total of 4 ties and 2 cribs is involved in the sampling. The sampling plan will provide 36 ballast and 12 subgrade samples. About 20 lb of samples will be taken at each sampling location, totaling about 720 lb ballast and 240 lb subgrade materials per test section. The ballast samples will be used for the index property tests and the triaxial tests. The subgrade samples will mainly be used for the index property tests, and classification tests including moisture content and gradation, supplementing to the boring samples.

Care will be exercised to ensure representative and quality sampling throughout the test sections. All the samples will be carefully bagged in plastic-lined cloth sample bags with proper identification, and will be shipped to the University of Massachusetts for required tests. They will be weighed at the site and upon arrival in the laboratory as well.

#### 5.8.7 Railroad Assistance

The following assistance from the subcontracting railroads will be needed for the ballast physical state tests:

- (1) Shut down the test section during test period.
- (2) Ensure safety of test crews at the site.
- (3) Provide 2 to 3 man track gang to unfasten, remove, and replace ties as needed, and to replace ballast removed for various tests.
- (4) Restore track to original conditions existing prior to tests.
- (5) Provide track maintenance and traffic history prior to tests, and information on any significant environmental changes which have occurred.

### 5.9 Ballast Index Property Tests

#### 5.9.1 Introduction

The objective of the proposed ballast index property tests are to provide fundamental information needed for classification of ballast materials and for

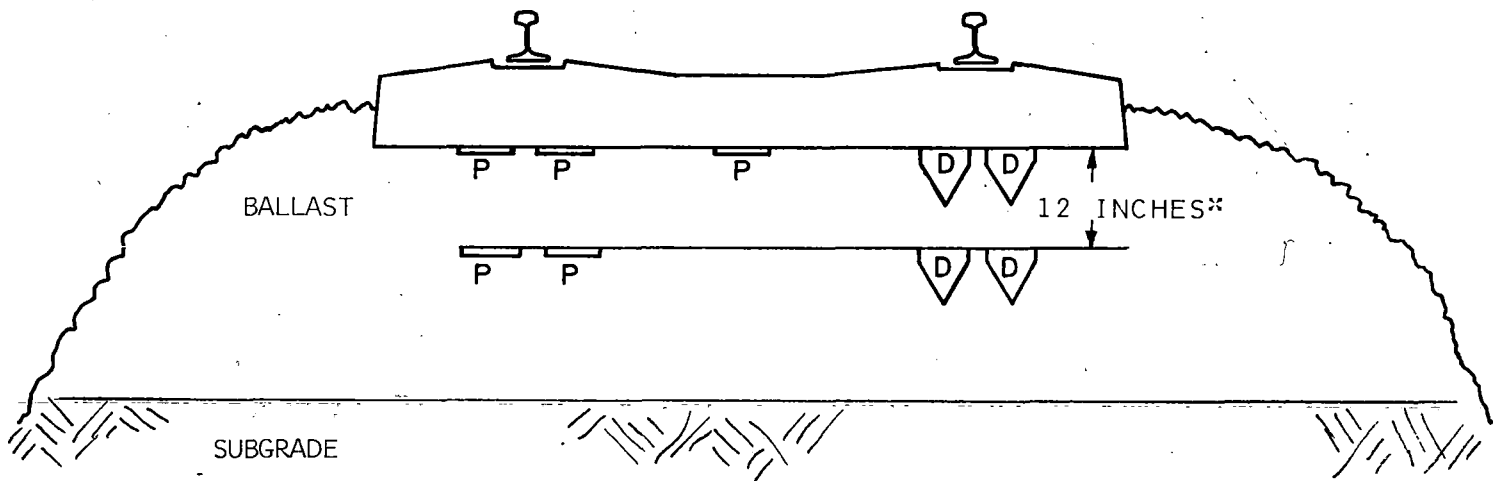

BALLAST

12 INCHES\*

SUBGRADE

P= PLATE LOAD TEST

D= BALLAST DENSITY TEST

\*UNLESS SUBGRADE IS WITHIN 18 INCHES OF TIE BOTTOM

FIGURE 5.8-5. TYPICAL CROSS SECTION OF BALLAST PHYSICAL STATE TESTS

relating ballast properties to observed track performance. Many index property tests have been developed for characterizing both physical and chemical properties of ballasts. However, they serve as only indirect indicators of potential in-service behavior. At present, no acceptable method of relating the index properties to suitability of ballast exists, simply because the index property tests quite often evaluate characteristics of the individual particles making up the ballast materials, and proven methods or criteria for rating ballast in terms of its effects on track performance are not available. Rather, the index properties are currently used as a basis for establishing some minimum specifications or guidelines for selecting ballast.

### 5.9.2 Scope of Tests

Since this study concerns existing ballasts, only important and significant tests should be included in the testing program. Based on the literature review (References 2, and 3), the following tests have been selected on the ballast materials:

- (1) Gradation test.
- (2) Liquid and plastic limit tests on material finer than No. 40 sieve.
- (3) Specific gravity tests on material both coarser and finer than No. 4 sieve.
- (4) Water absorption test on material coarser than #4 sieve.
- (5) Chemical soundness on material coarser than #4 sieve.
- (6) Los Angeles abrasion test on material coarser than #4 sieve.
- (7) Composition analysis on three separate fractions, such as material larger than #4 sieve, between No. 4 and No. 40 sieves, and smaller than No. 40 sieve.
- (8) Descriptive tests on material coarser than #4 sieve, such as visual estimation of angularity and sphericity, and hardness.

### 5.9.3 Test Procedures

Figure 5.8-6 illustrates the proposed sample preparation and test sequences for the index property tests. Detailed procedures for the sample processing and tests are described in Appendix E.

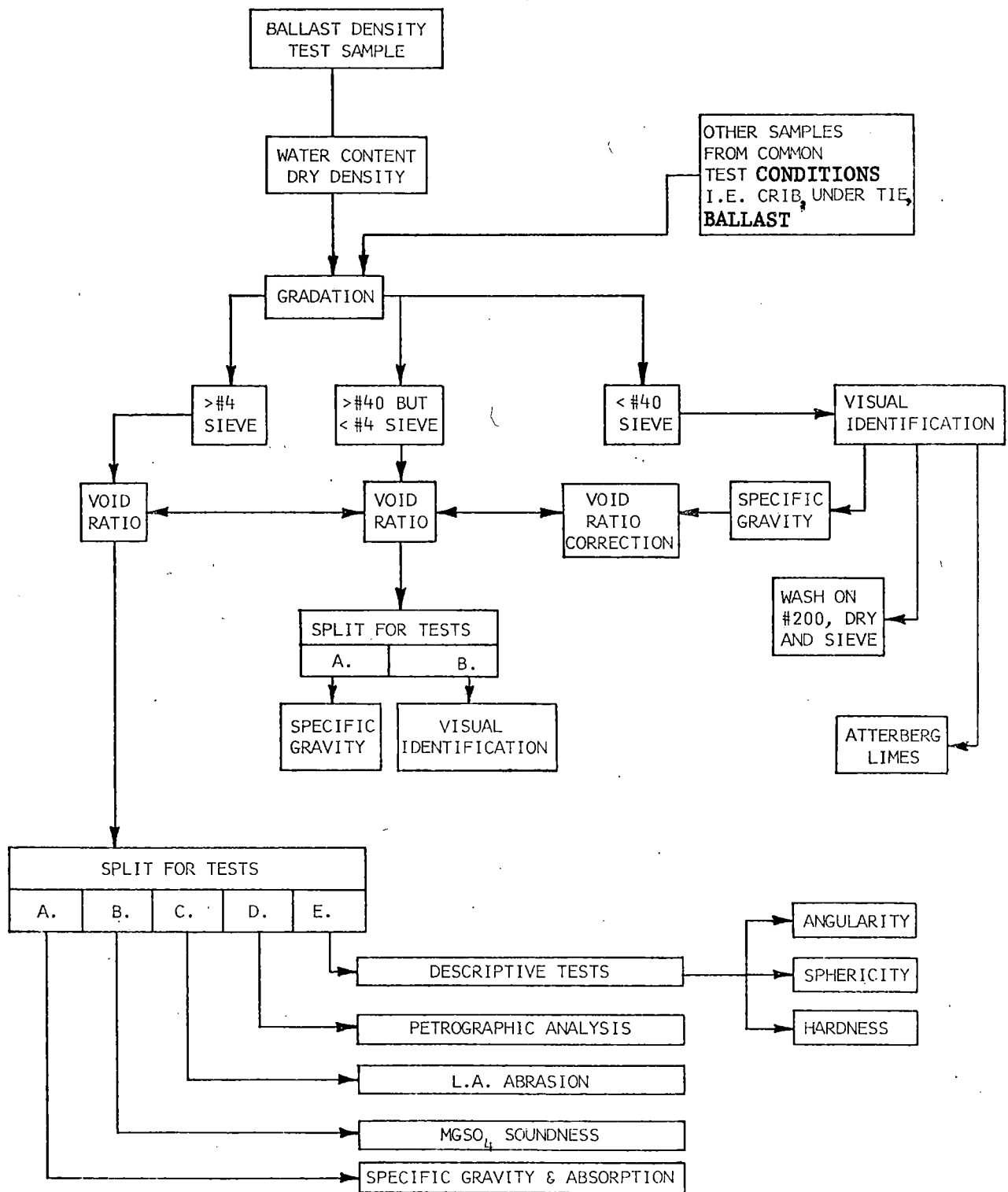

FIGURE 5.8-6. SAMPLE PROCESSING FLOW CHART FOR BALLAST AND SUBBALLAST INDEX TESTS

One complete series of tests defined in the flow chart will be performed on each representative ballast material type.

The number of series of the index property tests to be performed on each material type will be determined after initial evaluation of material variation between different sampling locations. Some evaluations will include visual inspection of all the samples, and gradation analysis on randomly selected, representative samples from each different sampling location such as shoulder, rail area, and center. If the initial sample evaluation indicates significant difference between the samples from different sampling locations, one complete series of the index property tests will be performed separately all the representative sample groups.

#### 5.9.4 RR Assistance

1. Track Time - two separate periods of 5 hours each.
2. Safety - flag man and communications with dispatcher.
3. Track maintenance and traffic history.
4. Flat car for drilling.
5. Labor to remove and replace ties and fasteners, open and restore cribs.
6. Work train reaction vehicle. (loaded hopper car)
7. Liaison official to communicate with BCL & UMASS and coordinate RR assistance.

### 5.10 Subsurface Investigations

#### 5.10.1 Objectives and Scope

The objectives of the proposed subsurface investigations are to characterize the subsoil conditions under the test track, and to obtain needed soil properties for defining the subgrade characteristics in the correlation analyses and methodology development.



The proposed subgrade investigations include: (a) Dutch cone penetration tests, (b) standard penetration tests, and (c) borings for undisturbed sampling. These tests will be conducted in one or two trips to each site. If two trips, the first trip will involve the Dutch cone sounding for initial evaluation of subsoil identification and stratification. The second trip will involve the standard penetration tests for obtaining visual samples, and borings for obtaining undisturbed tube samples. The two trips may be combined, but the core work must precede the drilling.

The prime objectives of the Dutch cone penetration tests are to evaluate the subsoil stratification and degree of uniformity within a stratum along the track in a relatively short period of time and to obtain values to use in estimating soil properties. The results from the Dutch cone probing will provide the advance information on the subsurface conditions for determining the scope and locations of the subsequent subsurface investigations, i.e., standard penetration tests and undisturbed sampling. The locations of other geotechnical investigations such as ballast physical state tests may also be influenced by the observed subgrade conditions.

At the very beginning of the geotechnical investigation, the Dutch cone penetration tests will be conducted at intervals of 50 to 100 ft throughout the test section along the centerline of the track. Planned depth of the probing will be to about 20 to 25 ft down from the top of the tie for 4 or 5 of the soundings. The remaining 8 or 9 soundings will be to a depth of 10 ft below the top of the tie. All of the soundings will be done in the crib area between the rails. However, this range may be reduced or extended depending on the existing conditions of the subsurface layers.

The standard penetration test (SPT) will supplement the Dutch cone probing in determining the penetration resistance of subgrade layers. However, more importantly, it will provide soil samples (disturbed) for direct visual identification of soil strata under the track, and for index property and classification tests.

At each site, two SPT will be conducted down to a depth of 20 to 25 ft from the top of the tie. Representative locations for the SPT will be determined based on the results from the Dutch cone probing. However,

it is important that these samples be taken between the rails, or at least between the ballast shoulders in order to properly represent the conditions influencing track performance.

An important phase of the proposed subsurface investigation is conducting borings to obtain undisturbed samples. Two borings requiring a 4 to 6-in. diameter cased hole will be drilled into the subgrade layers to obtain high quality undisturbed soil samples, for the laboratory repeated load triaxial tests for material property characterization. Exact locations of these two borings will be determined again based on the results from the Dutch cone sounding to obtain representative soil samples throughout the test section. However, these samples must be taken below the area supporting the track. The sampling will be continuous from the top of the subballast layer down to a depth of about 5 ft, which is the zone of subgrade that has the greatest influence on track performance. The top of the subgrade will be examined closely to identify local rutting under the ties, potential pumping, ballast penetration and drainage problems. Properties for the portion of subgrade below the undisturbed sampling will be estimated by correlation with the cone and SPT soundings. However, the depth of undisturbed sampling will be extended if subgrade problem zones are encountered below a 5 to 10 ft depth.

#### 5.10.2 Test Equipment

A typical Dutch cone penetrometer consists of a 1.4-in.-diameter cone tip with a short pipe sleeve for side friction measurement. This pipe sleeve has the same diameter as the cone and is located immediately above the cone. No casing is required so the disturbance in sounding is limited to approximately a 1.5-in.-diameter hole, unless ballast must be removed to permit the cone to reach the subgrade. Tests are being conducted now to see if removing and shoring crib ballast will be needed. If it is, then the ballast will be replaced by hand after a sounding is completed. No other track maintenance is expected to be needed after the cone tests.

Standard penetration test requires a drilling rig equipped with specified size sample and driving hammer. ASTM specification D-1586 provides the detailed procedures and equipment required for the SPT. The standard penetration resistance is the number of blows required to drive a sampler of 2-in. OD

by 1.375-in. ID into the ground for 12 in. with a 140-lb weight falling 30 in. A 6 to 8-in. diameter hollow-stem auger will be used to advance the drill hole and laterally support the soil and ballast bed. The SPT sampler will be inserted into the auger stem for the test.

The ballast bed in the center of the crib will be disturbed considerably by this operation. Therefore, this must be done before the track is tamped. The cribs will be refilled after the drilling, and consideration also will be given to filling the drill holes during casing or auger removal.

The drilling method for undisturbed sampling will be of a rotary wash type. Heavy-drilling mud and/or a casing will be needed for high quality sampling. Ballast will have to be removed and the ballast bed laterally supported during the drilling. The type of sampler will be selected based on the initial identification of soil type and conditions from the Dutch cone probing. The required sampler hole will be at least 6-in. diameter.

For the Dutch cone probing the use of a commercially available, electronic cone penetrometer, mounted on a self-propelled truck is proposed. A separate truck-mounted drilling rig will be required for the SPT and undisturbed sampling. The trucks preferably will be fitted with rail wheels, but if this is not feasible, a flat car will be needed for mobility on the rail at the test site. The use of rail wheels is believed to be a much more economical and versatile approach. Thus potential drilling firms are being consulted to determine the feasibility of providing rail wheels on their vehicles.

### 5.10.3 Test Schedule

Dutch Cone Penetration Tests. As discussed earlier, the Dutch cone penetration tests should be performed in advance of the first site visit for other field measurements such as the ballast physical state tests. Preferably, all of the field sites should be tested on one continuous trip by the same crew. This will ensure consistency and minimize cost. At the present time, hiring of a commercial firm is proposed to perform the cone probing. Only supervisory personnel will be needed from UMass for coordination of these tests. The Dutch cone penetration test will require approximately 8 hours of track time per test section. This track time must be scheduled within a 40-hour period of the arrival of the test crew at the site, but it does not have to be consecutive hours. The cone test can be performed at night. No less than

two-hour blocks of time on the track should be scheduled, and one-hour notice is required to permit preparing the track again for train operation.

Standard Penetration Tests. After initial evaluation of results from the Dutch cone probing, the test site will be revisited with drilling crews on a separate trip for the subsequent standard penetration tests and undisturbed sampling together. It may be possible to coordinate the schedules of the drill work and the cone work so that only one trip will be necessary. In which case, the drilling work will directly follow the cone work. Preferably this work will be performed before the first site visit for the physical state tests. Because of disturbance to the ballast during this sampling, the drilling must be completed before the scheduled track maintenance. Staffing for this drilling crew will be determined later after further assessment of available equipment. Hiring of a commercial firm is anticipated, however. The same crew will be used at all of the east coast sites if possible. A separate crew will probably be used in Illinois to reduce mobilization cost.

Approximately 8 hours of track time is needed for this phase of the subsurface investigations. This track time must be scheduled within a 40-hour period of the arrival of the test crew at the site, but it does not have to be consecutive hours. No less than 4-hour blocks of time should be scheduled and at least 2 hours notice given to prepare the track for train service. The drilling work can be done at night with lights.

#### 5.10.4 Undisturbed Sampling

Detailed procedures for undisturbed sampling will be specified for the drilling crews, based on the preliminary information indicated by the Dutch cone probing. These procedures will describe:

- (1) drilling procedures, including use of drilling mud and/or casing, cleaning of hole, and measurement of boring depth and water table;
- (2) sampling procedures, including techniques for tube penetration and sample withdrawal;
- (3) sample handling procedures during sampling, transportation, storage, and extrusion; and
- (4) field and laboratory logging procedures.

#### 5.10.5 Laboratory Tests (Disturbed Samples)

The disturbed samples obtained during the standard penetration tests will be subjected to visual inspection for soil identifications, and index property and classification tests. Careful logging of soil identification and stratification will be made during the visual inspection which will supplement the Dutch cone probing. The basic index property and classification tests will supplement the Dutch cone probing. The basic index property and classification tests will include moisture content, liquid limit, plastic limit, and gradation tests. If the subgrade material contains a significant amount of granular materials, maximum and minimum density tests will be done for determining relative density.

In-situ moisture content and density state will be determined from the undisturbed samples for the static and dynamic triaxial tests. The type and test conditions of the laboratory triaxial tests will be determined after careful inspection of soil type and field conditions. Further details of the laboratory testing program for the undisturbed sampling are discussed separately in Section 5.11 and 5.12.

#### 5.10.6 Expected Results (Disturbed and Undisturbed Samples)

- (1) Complete identification of soil stratification.
- (2) Soil classification and index properties.
- (3) In-situ moisture and density state.
- (4) Penetration resistances from both the Dutch cone probing and SPT.
- (5) In-situ shear strength of soil layer.
- (6) Stress-strain properties, both estimated from in-situ tests and determined from laboratory tests.
- (7) Correlation of soil properties determined from laboratory triaxial tests with SPT and Dutch cone in-situ results.

#### 5.10.7 Railroad Assistance

- (1) Scheduling for track time. (Four 2-hour segments, two 4-hour segments.)
- (2) Safety of field crews during track work.
- (3) One laborer for removing and replacing ballast as needed.

## 5.11 Laboratory Stress-Strain and Strength Testing

### 5.11.1 Purpose

The purpose of the stress-strain and strength testing is to provide properties needed for the correlation methodology. Primarily these properties are the resilient modulus and the permanent strain accumulation with repeated loading. Both are functions of material physical state and stress state. Thus a number of tests are needed on each ballast, subballast and subgrade material. Most of the tests will be repeated load triaxial tests, but the number of tests can be minimized by a few static triaxial tests to define limiting stress-strain and strength conditions.

### 5.11.2 Methods and Scope

The test methods and apparatus are described in detail in Appendix F, based on work from the first year of the SUNYAB DOT study [5-4]. This work is continuing, so that further improvements in apparatus and procedures that are achieved will be incorporated in this concrete tie study.

The minimum number of tests required is estimated as 45. This is based on 3 sites, 3 materials, and 5 samples or test conditions per material. The physical states to be used will be determined from the field conditions, and the stress levels will be determined from preliminary computer analysis. It is anticipated that the 5 ballast tests will include at least 2 density states and 2 stress levels. The subballast and subgrade tests will be done at 2 moisture contents and 2 stress levels. However, it is important that the test format remain flexible until the nature of the material is determined.

## 5.12 Moisture Monitoring and Sampling

### 5.12.1 Introduction

Moisture content of the ballast, subballast and subgrade layers will be obtained by two methods. First, appropriate samples returned to the laboratory will be oven dried. These samples will be available only during the 4 site visits spaced at about 6-month intervals. Second, to observe moisture changes between site visits, sensors will be installed for remote readout, and these will be monitored on approximately weekly intervals.

### 5.12.2 Oven Samples

Oven drying to obtain moisture content will be accomplished from several sources:

1. From the SPT samples and from the tube samples during subsurface investigations. This will occur only during the first site visit.
2. From samples of ballast and subballast taken in connection with the plate load tests and the density tests. These will be available on the first and last visits.
3. From hand augering near the moisture sensor location for the intermediate visits.
4. From samples of subballast and subgrade taken during installation of the moisture sensors on the first site visit.

The procedures for oven drying are well-established and commonly used in practice. The minimum sample size in each case will be based on particle size of the material, larger samples being required for the ballast.

### 5.12.3 Moisture Sensor Instrumentation

The method planned for monitoring moisture changes over the period of the test is patterned after the prototypes developed by Selig and Wobschall at the State University of New York at Buffalo. Most alternative measurement techniques operate by measuring resistance or capacitance of a sensor

constructed of material such as gypsum, nylon or fiberglass blocks which absorb moisture from the surrounding soil. These sensors are very sensitive to placement, soil structure, and soil composition and they exhibit large hysteresis during moisture fluctuations. As a result they are not accurate or precise enough for most engineering applications. These problems can be minimized by incorporating the moist soil itself as part of the electrical circuit.

The recommended moisture sensor responds with an electrical frequency of oscillation based on the electrical capacitance properties of the soil, which can then be directly correlated to the moisture content of the soil. The system works best in partially saturated soils and at low moisture contents. At high moisture contents, depending on the material, the soil electrical conductivity may become so high as to cause the circuit to become insensitive to further moisture increase. The working upper limit will diminish as the pore fluid conductivity increases, such as from dissolved salts. Soil composition effects on sensor response can be taken into account by proper calibration as long as composition does not change excessively during monitoring at a particular location. Unsatisfactory results may occur in applications in which the pore fluid composition changes in an unknown way with time so that calibration cannot correct for the errors in predicted moisture content.

The moisture sensor (Figure 5.12-1) is cylindrical, measuring 4 in.-long by 2 in.-diameter. Inside of each sensor is a circuit board with the required electronics. Each sensor is environmentally sealed for long term stability. Placement is done using either a 2-inch borehole or by compacting soil around the sensor.

The remainder of the system is a portable readout unit housed in a sturdy, sealed case, which utilizes a digital display and is powered by either a built-in, rechargeable battery or by 110V AC current. The sensor is attached to the readout unit by a single shielded coaxial cable of any desired length.

In operation the readout instrument provides power to the circuit in the sensor and triggers a sequence of four electrical oscillations. The frequency differences are determined automatically and displayed.



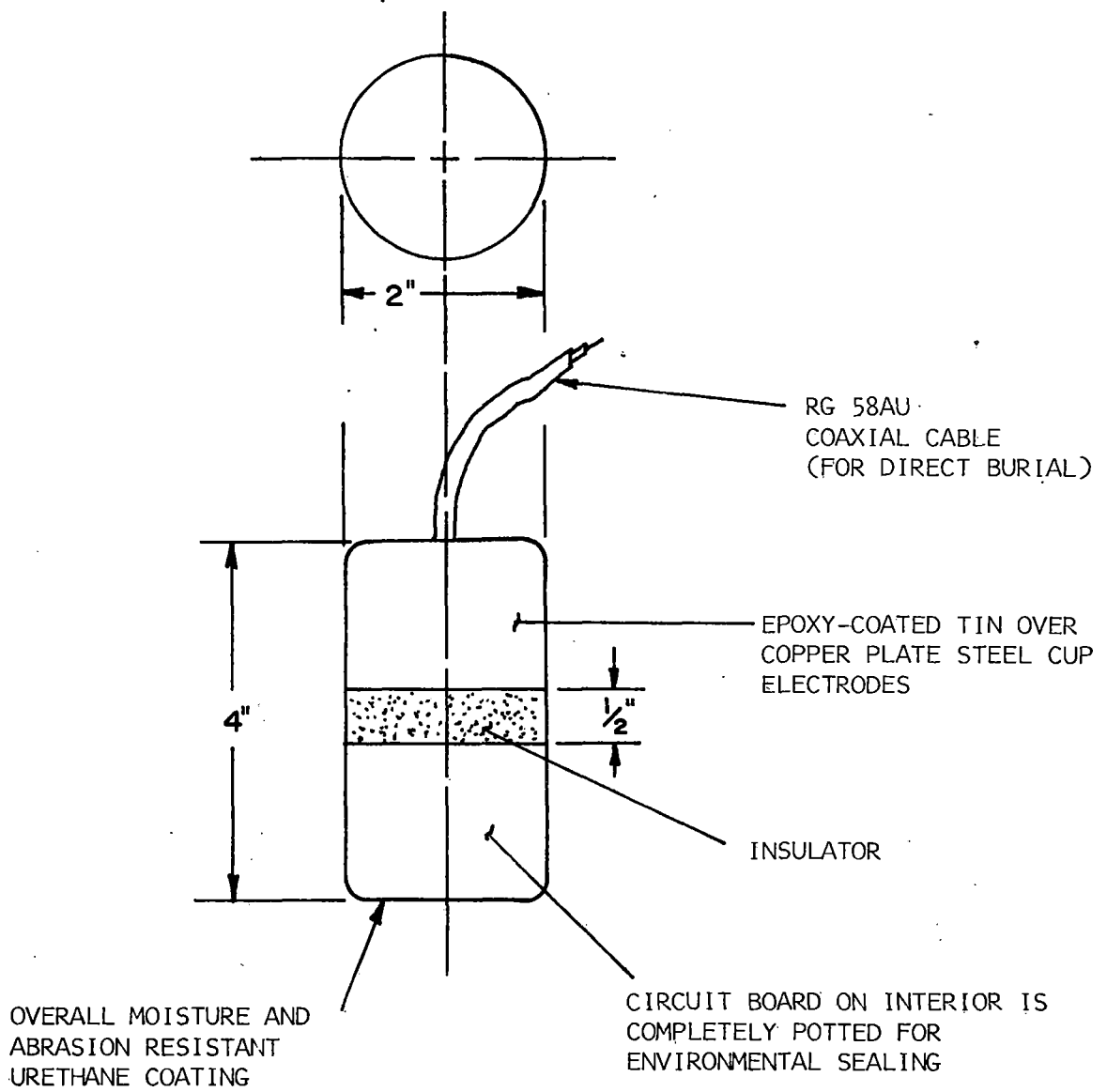

FIGURE 5.12-1. CYLINDRICAL SENSOR

#### 5.12.4 Moisture Sensor Installation

Seven sensors will be installed in each site. Three will be placed in the subballast and three in the subgrade. The seventh will be located where needed most based on the existing subsurface conditions.

Placement in the subgrade is done in a 2-in.-diameter hole made by a thin-wall tube cutter. The sensor will thus be in contact with undisturbed soil. In the subballast the material will be recompacted around the sensor to represent as closely as possible the undisturbed conditions. To avoid extra track disturbance, the tie locations for these sensors will be those assigned to the density and plate tests conducted prior to track maintenance.

The electrical cables will be brought out past the shoulder of the ballast section at a depth below the tamping zone to avoid disturbance during track maintenance. A junction box will be installed away from the track to provide a secure location for the ends of the cables. The readings will be obtained by carrying the readout instrument to the junction box and manually connecting each sensor in sequence. It is anticipated that a local resident can be selected to take the readings at least once each week throughout the test period.

#### 5.12.5 Moisture Sensor Calibration

The readings of "Apparent Capacitance" from the readout unit are related to moisture through the use of calibration curves (illustrated in Figure 5.12-2) established with a sample for, and of, each soil condition. These calibration curves may be established by either a laboratory method (for greatest accuracy) or by a field installation method. All of the sensors will be laboratory calibrated in advance using standard liquids and in representative soil materials. This will permit correlation between sensors. One sensor, like those installed, will be calibrated again after installation using recovered soil samples from each site.

In establishing and using these calibration curves, it is necessary to realize that the "Apparent Capacitance" readings are related to "Volumetric Moisture Content ( $M_v$ )," which is the ratio of the volume of water to a

unit volume of soil. When only relative changes in moisture are being considered, relative changes in "Volumetric Moisture Content" may be utilized. When the more common "Moisture Content (w)" - which is the ratio, expressed as a percentage, of the weight of water to the weight of dry soil in a unit volume - is desired, it may be derived from the "Volumetric Moisture Content" by the formula:

$$w = 100 M_v / d_d$$

where

$d_d$  is the dry density of the soil.

To provide a calibration curve by laboratory methods, the sensor is placed in the middle of a plastic container at least 6 inches in diameter and at least 6 inches deep, and moist soil is compacted around it. The level of compactive effort is not important. However, the density must be uniform throughout the container. As an alternative, the container may be compacted full of soil and a hole bored for the sensor just as done in field installation. After the container is filled and the soil surface leveled, a reading is taken of "Apparent Capacitance" and is plotted as the Y-axis reading. The corresponding X-axis reading is obtained by determining "Volumetric Moisture Content" by measuring the soil volume in the calibration container and determining the amount of water by drying the soil in the oven. The rest is repeated with soil samples at different moisture contents to provide sufficient points to construct a calibration curve such as is shown in Figure 5.12-2.

The simplest calibration procedure consists of taking an "Apparent Capacitance" reading with the sensor in the air before installation and plotting the reading on the Y-axis as the origin of the calibration curve. After installation, a reading of "Apparent Capacitance" is taken and plotted as the Y-axis location of the point. The X-axis location is determined by taking a sample of the soil where the sensor is installed and determining its "Moisture Content" (percentage ratio of weight of water to dry weight of soil). If the soil dry density does not change significantly with the moisture changes after installation, then the calibration can be expressed directly in terms of moisture content (w), rather than in terms of volumetric moisture content ( $M_v$ ). This avoids the need to make a field density determination to use the moisture sensor. This field calibration procedure will be used for each sensor to check the laboratory calibration.

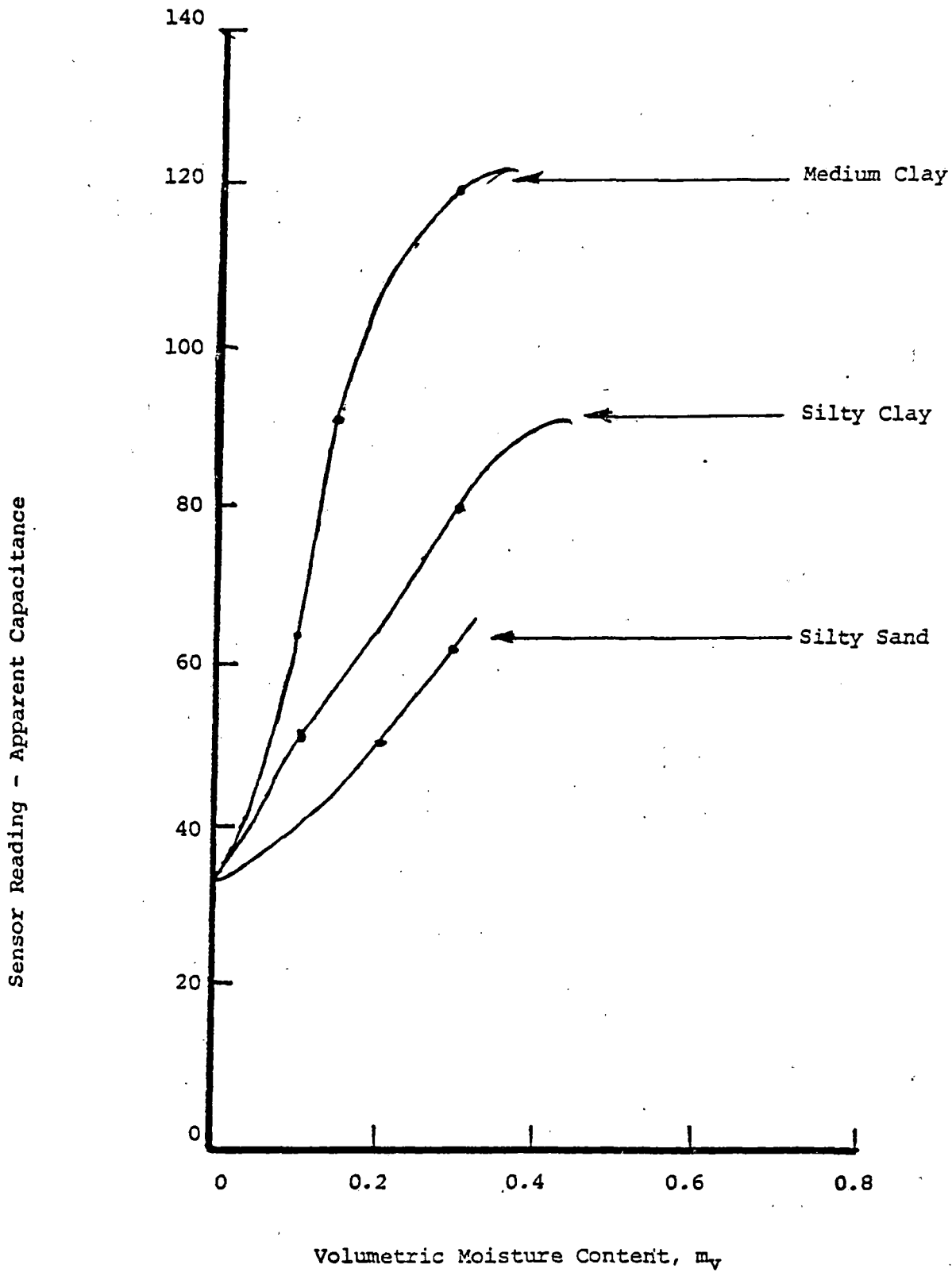

FIGURE 5.12-2. TYPICAL CALIBRATION CURVES (TYPE A SENSOR)

#### 5.12.6 Railroad Assistance

1. Labor to assist in sensor cable installation and in setting up readout box next to track.
2. Authorization for a local resident to enter the property and take readings 1 or 2 times per week.

#### 5.13 Weather Information

The U.S. Weather Bureau will be contacted to locate the weather stations closest to the test sites. Information on daily precipitation and average daily temperature will be collected. Although variance between the site and the local station may occur on any day, over a period of weeks the averages are expected to be suitable for use in establishing environmental differences between sites.

## 5.14 Survey-to-Benchmark Measurements

### 5.14.1 Initial Installation

- (1) Establish three benchmarks in each designated test section as illustrated in Figures 5.14-1 and 5.14-2. See the definitions of test sections in Figures 4-1 through 4-4.
- (2) Use a random method to select the ties for STB sites in each test section. Select 10 percent of ties at the Chessie site and 5 percent of ties in all other sites. Mark each selected tie.
- (3) At each designated tie, polish an area on each rail base to permit the scribing of a clearly visible "X" approximately one inch from the edge of the rail base. Spray a clear protective coating on the area to protect the mark.
- (4) Mark an appropriate location on the adjacent top surface of the tie, on each side of the track.

### 5.14.2 Vertical Elevation Measurements

- (1) Set up the theodolite near the center of the test section and approximately 50 feet from the track, as shown in Figure 5.14-3(a). Reading elevations to the nearest 0.001 ft., shoot the following locations:
  - (a) each benchmark
  - (b) each designated tie and rail location
  - (c) each benchmark for a second time.
- (2) For a small number of measurements, calculate rail-to-benchmark and tie-to-benchmark elevations and compare with previous measurements, to insure the elimination of any gross errors.

### 5.14.3 Horizontal Distance Measurements

- (1) Establish the sight lines illustrated in Figure 5.14-3(b) by alternately setting up the transit over each of the benchmarks. Accurate placement of the theodolite is very important

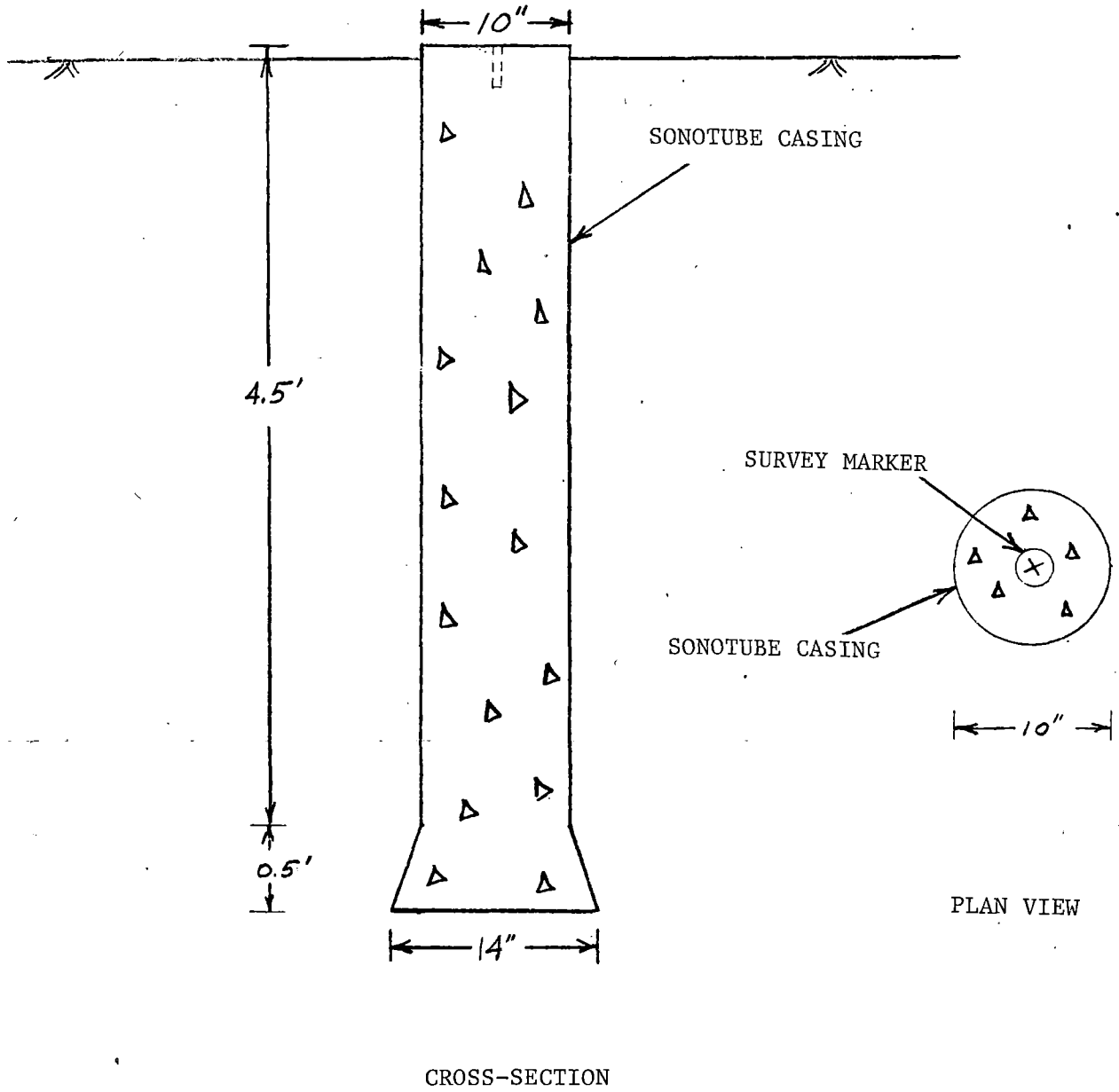
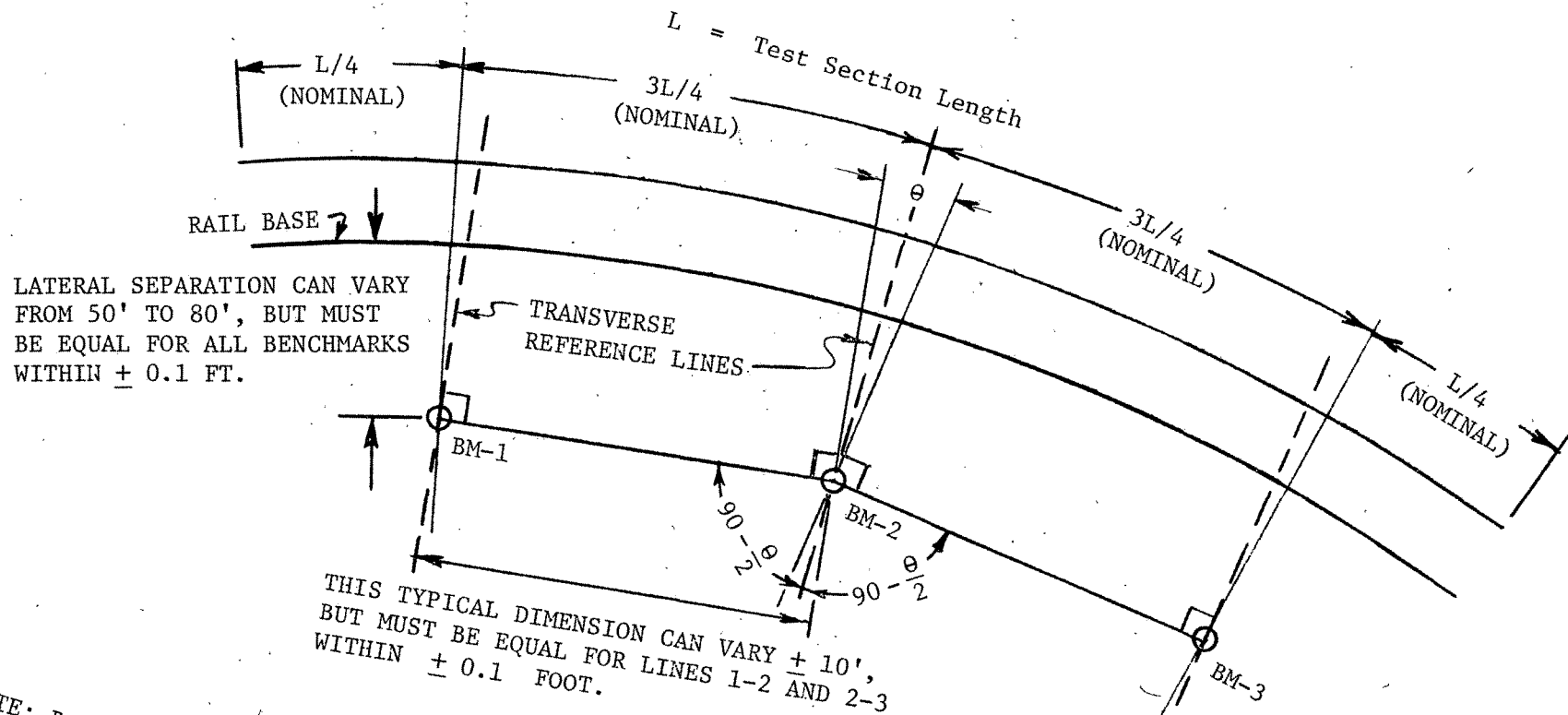

FIGURE 5.14-1. TYPICAL BENCHMARK CONSTRUCTION



NOTE: Benchmark arrangement for tangent track is a special case for which  $\theta = 0$ .

FIGURE 5.14-2. PLACEMENT OF BENCHMARKS IN A TYPICAL 400-FOOT TEST SECTION



MEASUREMENTS EVERY TENTH TIE,  
ON TIE AND RAIL BASE

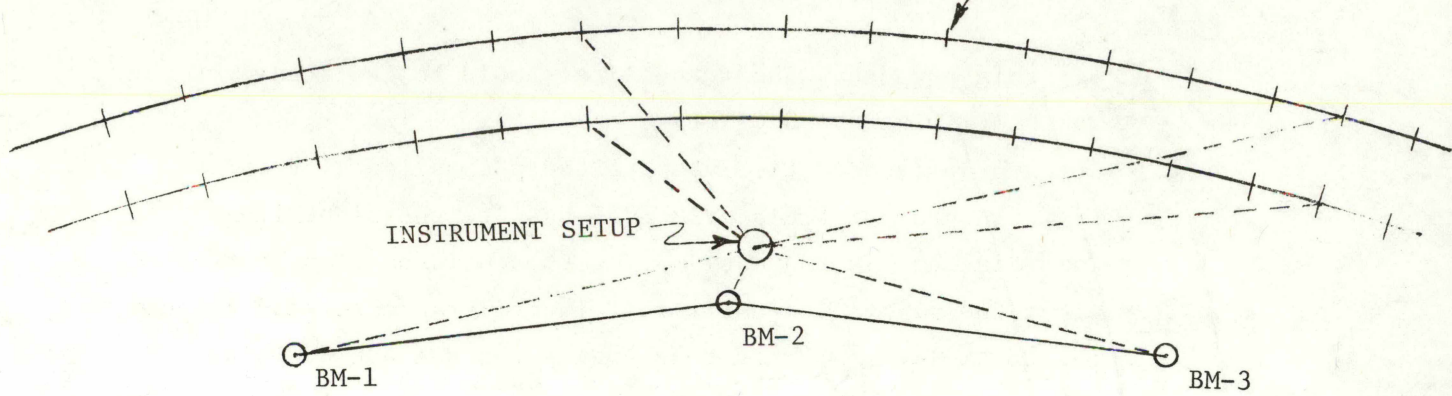

(a) Vertical Measurements

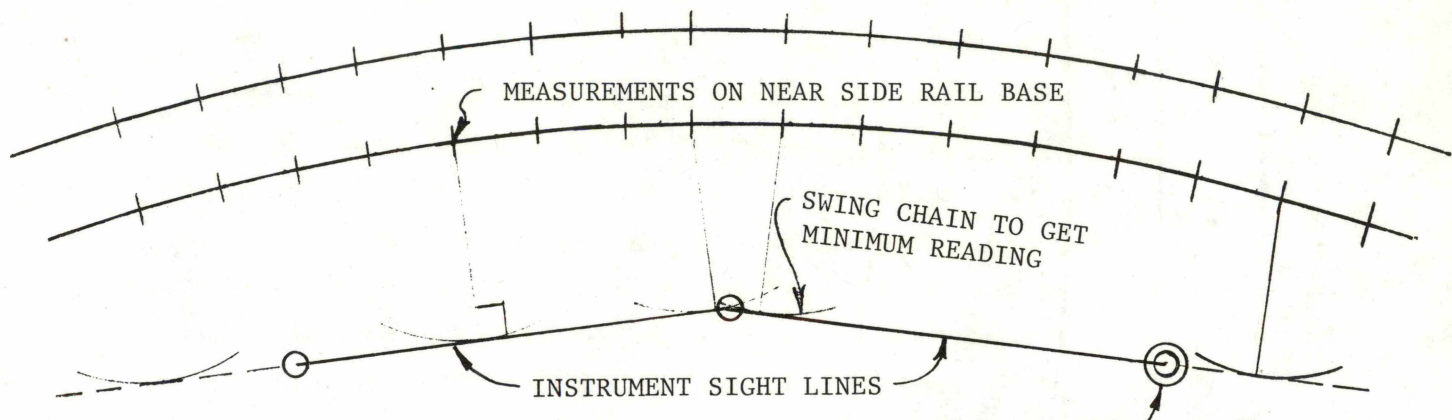

(b) Lateral Measurements

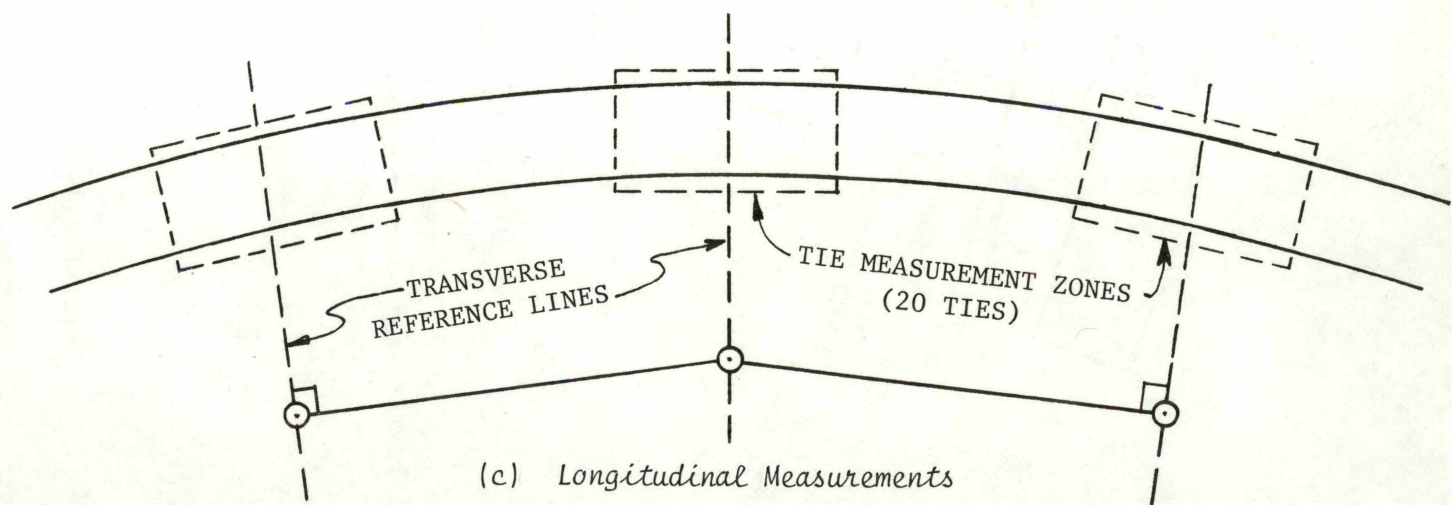

(c) Longitudinal Measurements

FIGURE 5.14-3. SURVEY-TO-BENCHMARK MEASUREMENT SCHEMES

for this purpose. The theodolite should be centered over the benchmark within  $\pm 0.01$  ft.

- (2) At each designated tie, measure the perpendicular distance from the nearest field side rail base to the sight line. This distance is found by moving the chain back and forth along the sight line until a minimum distance is read through the theodolite. Record readings to the nearest 0.01 ft.

#### 5.14.4 Longitudinal Rail Movement Measurements

- (1) Use the theodolite to establish the locations of the transverse reference lines illustrated in Figures 5-14-2 and 5.14-3(c). read angles to the limit of accuracy of the instrument, which should be  $\pm 1$  second of arc.
- (2) For the first measurement, place permanent markings on the base of each rail to define the original position of the rail under the transverse reference line at each STB site.
- (3) For all subsequent measurements, place a temporary mark on each rail base to define the current position of the rail under the transverse line. Measure the distance from the current mark to the original mark, to the nearest 0.01 inch. Record movement as positive if the original mark has moved in the direction of increasing tie numbers relative to the transverse reference line.

## 5.15 Tie Movement Measurements

### 5.15.1 Equipment

- (1) A spacer bar is required to indicate deviations in longitudinal tie spacing of  $\pm 4''$ .
- (2) A large protractor should be constructed of clear plastic to indicate tie skew deviations of  $\pm 2.25$  degrees. This skewing angle would be caused by a difference in longitudinal position of opposite ends of the tie of  $4''$ .

### 5.15.2 Measurement Procedure

- (1) Record data separately for each section of track where the tie/fastener combination remains the same. The data will consist simply of numbers of exceedances.
- (2) Walk the track and inspect all ties for spacing deviations ( $> \pm 4''$ ) and skew ( $> \pm 2.25$  degrees). Where exceedances are suspected, measure:
  - a. longitudinal spacing along the centerline of the track
  - b. skew of the ties with respect to one rail base.

Use the following signs:

- a. Spacing deviation is positive for spacing greater than nominal
- b. Skew is positive counterclockwise looking down on the track.

Thus, the exceedances will fall in one of the following categories:

| <u>TIE SPACING (INCHES)</u> | <u>TIE SKEW (DEGREES)</u> |
|-----------------------------|---------------------------|
| + 4"      - 4"              | + 2.25 deg.   -2.25 deg.  |

## 5.16 Rail Creep Measurements

### 5.16.1 Markings

Rail creep will be measured at all ties where vertical and lateral Survey-to-Benchmark measurements are made. Place creep markings during the first site visit, after the surface-and-line maintenance. Paint lateral

strips, in-line with each other, on each field side rail base and on the adjacent top tie surface.

#### 5.16.2 Measurements

Measure creep at the end of the first site visit and once during each subsequent site visit. Sign convention: if the rail has moved relative to the tie in the direction of increasing tie numbers, this is positive creep.

### 5.17 Tie/Fastener/Pad/Insulator Inspection

#### 5.17.1 General

The inspection form is illustrated in Figure 5.17-1. All ties in the designated test section (all concrete ties) should be inspected for all items on the form except tie face cracking. Center cracking visible from the top of the tie will be inspected on all ties.

Tie face cracking will be inspected for ten percent of the ties at the Chessie site and for five percent of the ties at all other sites, during the first and last site visits only. The first inspection should be made before surface-and-line maintenance. The crib locations should be selected randomly, except that they should be separated by at least three cribs. If locations are selected with less separation, make additional selections. Inspect the faces of the two ties adjacent to each crib. In addition, all previously identified major face cracks (those appearing on two or more surfaces) should be examined on all inspections.

There is ONE EXCEPTION to this plan for opening cribs: avoid the locations of ballast density and plate bearing tests. Do not open a crib if it is either the location of one of these tests or is adjacent to a test location. Lateral tie push tests must be performed before opening cribs.

Only one inspection will be made during the first site visit. This should be completed before the surface-and-line maintenance.

TEST SECTION \_\_\_\_\_ DATE \_\_\_\_\_ INSPECTOR \_\_\_\_\_ RAIL I.D.: A \_\_\_\_\_ B \_\_\_\_\_

| TIE NUMBER | TIES      |    |    |    |              |     |     |     |     |     | FASTENER CLIPS |    |    |             |    |    | FASTENER SHOULDERS |    |    | INSULATORS  |    |    |             |    |    | PADS        |   |        |   |   |
|------------|-----------|----|----|----|--------------|-----|-----|-----|-----|-----|----------------|----|----|-------------|----|----|--------------------|----|----|-------------|----|----|-------------|----|----|-------------|---|--------|---|---|
|            | CRACKS    |    |    |    | CHIPS/DAMAGE |     |     |     |     |     | CRACK/BREAK    |    |    | DISLOCATION |    |    | LOOSE/BENT         |    |    | CRACK/BREAK |    |    | DISLOCATION |    |    | DISLOCATION |   | DAMAGE |   |   |
|            | RAIL SEAT |    |    |    |              |     |     |     |     |     | CRACK/BREAK    |    |    | DISLOCATION |    |    | LOOSE/BENT         |    |    | CRACK/BREAK |    |    | DISLOCATION |    |    | DISLOCATION |   | DAMAGE |   |   |
|            | CENTER    | AF | AG | BG | BF           | FSA | RSA | CEN | RSE | FSE | AF             | AG | BG | BF          | AF | AG | BG                 | BF | AF | AG          | BG | BF | AF          | AG | BG | BF          | A | B      | A | B |
| 1          |           |    |    |    |              |     |     |     |     |     |                |    |    |             |    |    |                    |    |    |             |    |    |             |    |    |             |   |        |   |   |
| 2          |           |    |    |    |              |     |     |     |     |     |                |    |    |             |    |    |                    |    |    |             |    |    |             |    |    |             |   |        |   |   |
| 3          |           |    |    |    |              |     |     |     |     |     |                |    |    |             |    |    |                    |    |    |             |    |    |             |    |    |             |   |        |   |   |
| 4          |           |    |    |    |              |     |     |     |     |     |                |    |    |             |    |    |                    |    |    |             |    |    |             |    |    |             |   |        |   |   |
| 5          |           |    |    |    |              |     |     |     |     |     |                |    |    |             |    |    |                    |    |    |             |    |    |             |    |    |             |   |        |   |   |
| 6          |           |    |    |    |              |     |     |     |     |     |                |    |    |             |    |    |                    |    |    |             |    |    |             |    |    |             |   |        |   |   |
| 7          |           |    |    |    |              |     |     |     |     |     |                |    |    |             |    |    |                    |    |    |             |    |    |             |    |    |             |   |        |   |   |
| 8          |           |    |    |    |              |     |     |     |     |     |                |    |    |             |    |    |                    |    |    |             |    |    |             |    |    |             |   |        |   |   |
| 9          |           |    |    |    |              |     |     |     |     |     |                |    |    |             |    |    |                    |    |    |             |    |    |             |    |    |             |   |        |   |   |
| 10         |           |    |    |    |              |     |     |     |     |     |                |    |    |             |    |    |                    |    |    |             |    |    |             |    |    |             |   |        |   |   |
| 11         |           |    |    |    |              |     |     |     |     |     |                |    |    |             |    |    |                    |    |    |             |    |    |             |    |    |             |   |        |   |   |
| 12         |           |    |    |    |              |     |     |     |     |     |                |    |    |             |    |    |                    |    |    |             |    |    |             |    |    |             |   |        |   |   |
| 13         |           |    |    |    |              |     |     |     |     |     |                |    |    |             |    |    |                    |    |    |             |    |    |             |    |    |             |   |        |   |   |
| 14         |           |    |    |    |              |     |     |     |     |     |                |    |    |             |    |    |                    |    |    |             |    |    |             |    |    |             |   |        |   |   |
| 15         |           |    |    |    |              |     |     |     |     |     |                |    |    |             |    |    |                    |    |    |             |    |    |             |    |    |             |   |        |   |   |
| 16         |           |    |    |    |              |     |     |     |     |     |                |    |    |             |    |    |                    |    |    |             |    |    |             |    |    |             |   |        |   |   |
| 17         |           |    |    |    |              |     |     |     |     |     |                |    |    |             |    |    |                    |    |    |             |    |    |             |    |    |             |   |        |   |   |
| 18         |           |    |    |    |              |     |     |     |     |     |                |    |    |             |    |    |                    |    |    |             |    |    |             |    |    |             |   |        |   |   |
| 19         |           |    |    |    |              |     |     |     |     |     |                |    |    |             |    |    |                    |    |    |             |    |    |             |    |    |             |   |        |   |   |
| 20         |           |    |    |    |              |     |     |     |     |     |                |    |    |             |    |    |                    |    |    |             |    |    |             |    |    |             |   |        |   |   |
| 21         |           |    |    |    |              |     |     |     |     |     |                |    |    |             |    |    |                    |    |    |             |    |    |             |    |    |             |   |        |   |   |
| 22         |           |    |    |    |              |     |     |     |     |     |                |    |    |             |    |    |                    |    |    |             |    |    |             |    |    |             |   |        |   |   |
| 23         |           |    |    |    |              |     |     |     |     |     |                |    |    |             |    |    |                    |    |    |             |    |    |             |    |    |             |   |        |   |   |
| 24         |           |    |    |    |              |     |     |     |     |     |                |    |    |             |    |    |                    |    |    |             |    |    |             |    |    |             |   |        |   |   |
| 25         |           |    |    |    |              |     |     |     |     |     |                |    |    |             |    |    |                    |    |    |             |    |    |             |    |    |             |   |        |   |   |

86

FIGURE 5.17-1. TIE/FASTENER/PAD/INSULATOR INSPECTION FORM

## 5.17.2 Inspection Procedure

### a. Ties

- (1) Cracks. The lengths of all cracks should be entered to the nearest inch.
- (2) Chips/Damage. Enter the largest dimension of any chips or mechanical damage, to the nearest inch. For this purpose the following designations will define sections across the length of the tie:

FSA Field Side of Rail A

RSA Rail Seat of Rail A

CENTER Between the two rail seats

RSB Rail Seat of Rail B

FSB Field Side of Rail B

- b. Clips. The number and location of clips that are flush with the face of the shoulder (at the hole) or are within the shoulder hole shall be recorded. Location consists of inside rail field (IG), inside rail gage (IG), outside rail field (OF) and outside rail gage (OG).

### c. Fastener Shoulders

Enter: C if concrete around base of shoulder is cracked

L if shoulder is loose in concrete

B if shoulder is bent, twisted or broken.

- d. Insulators. The insulators shall be classified in accordance with condition codes.

A - Insulator in good condition

B - Broken or cracked corners

C - Cracked plastic

D - Badly damaged

F - Insulator has fallen out

G - Insulator has moved more than 1/2 inch.

The number and location of insulators meeting each code will be recorded. Locations consists of inside rail field (IF), inside rail gage (IG), outside rail field (OF) and outside rail gage (OG).

f. Pads. The number and cloation of pads that have move 1/2 inch or more in any direction shall be recorded. Location shall consist of tie number and inside or outside rail. If pad burned--so indicate.

e. Photographs

(1) Photograph all visible cracks and major cases of tie chips and damage.

(2) Photograph all major cases of damaged or dislocated pads, clips and insulators.

## 5.18 Gage Face Wear

### 5.18.1 Measurement Locations

Gage face wear will be measured at all ties designated for vertical and lateral survey-to-benchmark measurements.

### 5.18.2 Equipment

Gage face wear will be measured with a snap gage of the type planned for the Phase II experiments at FAST. These measurements will be made at 3/8" below the top surface of the railhead for direct comparison with FAST data.

### 5.18.3 Measurement Procedure

- (1) Define "zero" (no wear), for the snap gage by making 10 measurements on a control section of new rail for each rail section to be measured.
- (2) Measure lateral position of each gage face, relative to the previously established "zero", at all designated ties.



## 6. RAILROAD SUPPORT REQUIREMENTS

Railroad support requirements are needed in all phases of the measurement program. Required services include track maintenance, the collection of track geometry data, the provision of a work train to assist in the calibration of instrumentation and in the conduct of certain experiments, and the provision of personnel to insure the safety of the test crew, to communicate with the dispatcher and work train, to remove and replace designated ties and ballast and to provide other general assistance. The specific work items are defined below. On the Northeast Corridor, no work train or tie/ballast work will be required, but the remaining requirements will exist for about one day per site visit.

### 6.1 Surface-and-Line Maintenance

During the first site visit, after the installation of instrumentation and the conduct of an initial set of experiments, the railroad shall provide surface-and-line maintenance on the designated test sections. The test sections will consist of concrete tie track on the Chessie and N & W and of both concrete and wood tie track on the Santa Fe.

### 6.2 Track Geometry Measurements

Gage, crosslevel, surface and alinement data will be collected by the track geometry car operated by the railroad. It is recognized that scheduling of track geometry cars for a specific site and time is difficult, but it is expected that track geometry car runs will, at least, correspond in frequency with the interval of approximately six months planned between measurement cycles. To the extent possible, the railroad should adhere to the following target:

a. measurements within two weeks before and after the first site visit to document the effects of surface and line maintenance.

b. measurements within two weeks before or after the remaining three site visits.

In addition, the railroad shall provide access to the test section for the Department of Transportation T-6 track geometry car for track geometry measurements to be made at up to 4 selected times during the measurement program.

### 6.3 Locomotive and Car

To calibrate instrumentation and to perform measurements of vertical ballast modulus, a work train will be required containing one locomotive and one loaded hopper car. The train will be required for about four days on the first visit and for about one day on each of the three remaining visits. A work train with a flat car may also be required for the drilling operation prior to the first site visit.

### 6.4 Maintenance and Traffic Data

a. Consist Descriptions. Detailed consist descriptions for one month of traffic spanning each site visit should include:

1. date and time of train passage
2. the type of each car
3. the gross weight of each car
4. the overall gross weight of the train
5. direction of travel over the test site.

b. Tonnage Accumulation. Overall train tonnage should be accumulated, beginning with the first consist description and continuing for all traffic over the test section through the full period of the tests. Record intervals of data and accumulated tonnage should be no greater than one month. At double-track sites, the track must be designated.

In addition, any available records of tonnage accumulation from the installation of the test section should be provided to Battelle-Columbus. This information is desired for record intervals no greater than 3 months.

c. Maintenance Data. A record of all maintenance required for the test section should be maintained by the railroad and submitted to Battelle-Columbus at 6-month intervals starting from the initial site visit. Also,

any available data on the history of tonnage and maintenance since the installation of the test section should be submitted to Battelle-Columbus no later than April 1, 1979.

The Battelle-Columbus project manager should be notified at least 2 weeks prior to carrying out any track maintenance which disturbs the ballast section after the lining and surfacing to be conducted during the initial site visit. Emergency maintenance required to maintain normal train operations is excepted from this requirement, but Battelle-Columbus should be informed about this as soon as possible.

Names of suppliers of ballast for each test section including-- gradation, type, origin, approximate date of deposition. This includes any ballast deposited during the maintenance operation.

#### 6.5 General Assistance

The following approximate lengths of time have been estimated for each of the site visits:

- a. Preliminary site visits (one or two) to collect geotechnical data and install benchmarks: 5 days total
- b. First measurement site visit, which includes installation of instrumentation and two measurement sets: 15 days
- c. All subsequent site visits: 9 days.

During each of the site visits, unless otherwise noted, the railroad shall provide:

- a. A liaison official to whom all specific requests concerning all railroad services can be directed. The liaison official would not be expected to be on site on a full-time basis. Telephone contact will be adequate.
- b. Telephone or radio communication from the BATTELLE-COLUMBUS instrumentation van to the dispatcher to provide information about train schedules.
- c. A warning signal, by lights and sound, of trains approaching within two to five miles of the instrumentation van.
- d. A watchman for safety purposes whenever installation of instrumentation or other track work is in progress and during drilling.
- e. Coordination between the work train and the BATTELLE-COLUMBUS test crew while calibration of tests requiring the train are in progress, and for physical state tests and perhaps the drilling tests.

- f. 115-volt, 5 KVA, AC electrical power for the instrumentation van.
- g. Copies of train consists (conductor's tonnage reports) for all traffic through the test site during each site visit.
- h. Track crew to assist in the following activities:
  - 1. Removal and replacement of 4 ties and crib ballast.  
This must be done with minimal disturbance to the ballast under the ties. (Before and after tamping on first visit and once during last visit only.)
  - 2. Remove and replace rail fasteners on approximately 7 ties at each of 6 different locations for lateral tie push tests (before and after tamping on first visit and once during last visit).
  - 3. Removal of ballast before drilling and shaping of ballast section after drilling during the preliminary subsurface investigation work.
  - 4. Removal and replacement of ballast to permit application of strain gages to the ties (first time only plus some repair, as needed).
  - 5. General assistance for ballast density, tie push and plate bearing tests (before and after tamping on first visit and once during last visit).
  - 6. Removal and replacement of crib ballast (10 percent of cribs at Chessie, 5 percent at N & W and Santa Fe) in the concrete tie sections, once during each of the 4 regular measurement visits.

#### 6.6 Track Time

On the first and last visits to the three instrumented test locations (Chessie, N & W, Santa Fe), two separate segments of five continuous hours of track time will be required, as part of 2 days with a minimum of 8 hours each total track time. The segments can be scheduled at night if necessary to minimize interruption of traffic. During each time segment, one tie will be removed and the plate load bearing and ballast density tests will be performed. The subgrade characterization tests, to be performed on one or two preliminary site visits, will require 4 two-hour segments and 2 four-hour segments of track time. It is expected that the remaining measurements and installation/calibration activities can be scheduled around normal traffic.

## 7. DATA ACQUISITION AND RECORDING

Acquisition and recording of dynamic track response data will be accomplished with a FM multiplex system with a capacity for 42 data channels. Figure 7-1 is a block diagram of the data system. The signal conditioning modules will each contain fourteen signal conditioning amplifiers with individual, isolated strain gage power supplies and zero suppression balancing networks. Each amplifier drives the input of an IRIG constant bandwidth, voltage controlled oscillator (VCO). The fourteen VCO's in one module will be summed into a mixing amplifier/line driver which can drive up to 2000 feet of coaxial cable. This single coaxial cable plus a calibration control cable and a power cable will be required to connect each signal conditioning module to the mobile instrumentation laboratory. The FM multiplexes will be recorded on a wide band-I, Fourteen track magnetic tape recorder. Direct record bandwidth will be 300 Hz - 150KHz at 30 inches-per-second (ips). In addition to the multiplexes, a 100 KHz tape speed compensation signal and IRIG-B time code will be recorded. Wheel detectors and wide band dynamic data ( $\geq 2000$  Hz) will be recorded on remaining FM record tracks at DC-20 KHz bandwidth. Data quality will be verified by monitoring on a fibre optic oscillograph at the same bandwidth as the data will be reduced.

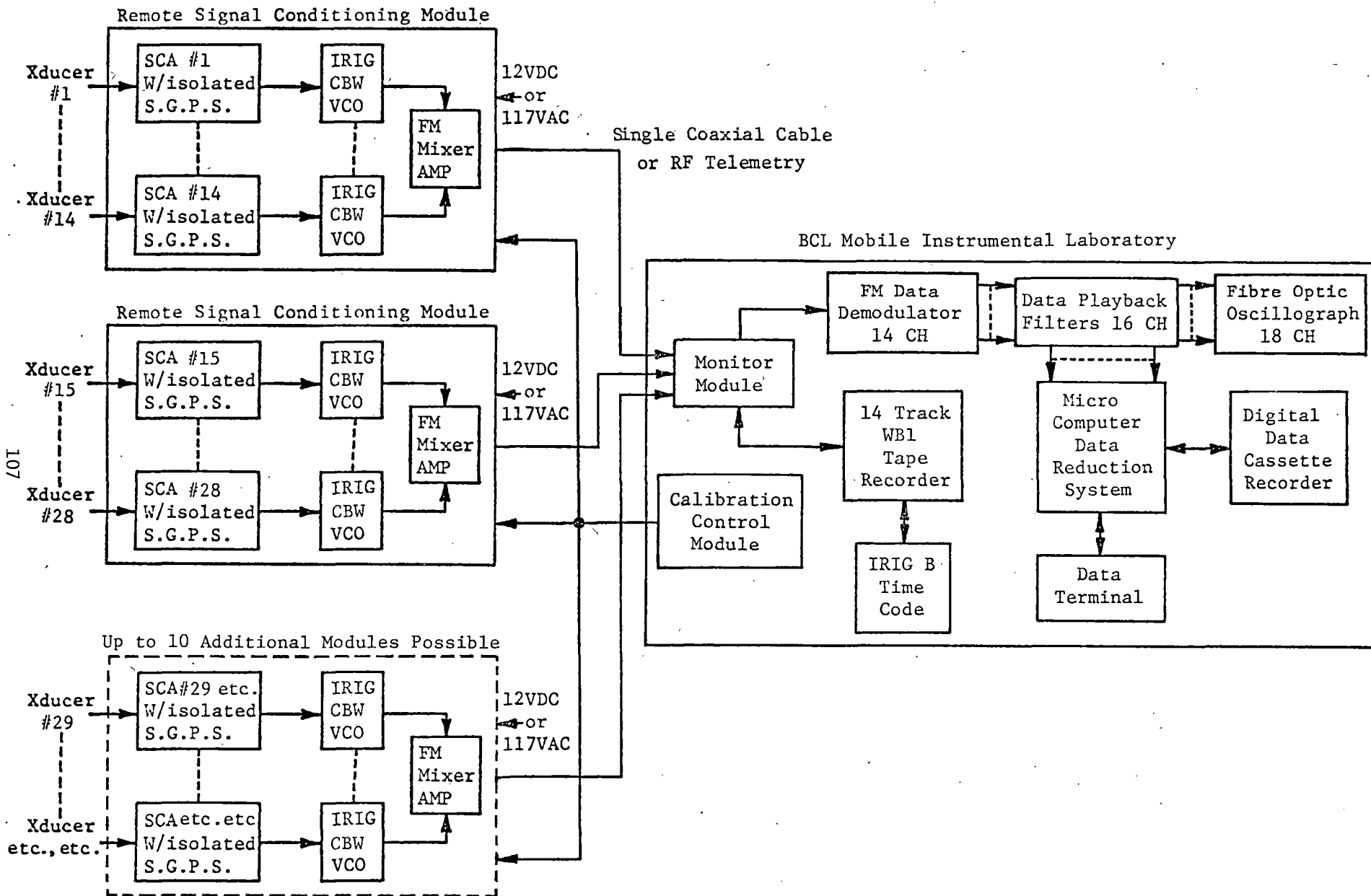

FIGURE 7-1. BLOCK DIAGRAM OF BCL FIELD DATA ACQUISITION SYSTEM

## 8. DATA ANALYSIS PROCEDURES

Initial data reduction of dynamic data will occur in the field using a microcomputer data reduction system. This operation will use a high speed (125 KHz) analog-to-digital convertor (A/D) which when driven by a micro-processor will convert up to 1500 samples per second per channel for a fourteen channel input. At a particular moment in time determined by the wheel detector pulse and a computed time delay based on train speed, all associated channels will be sampled, and those samples will be stored in a shared memory location. A second micro processor within the same system will correct for zero offsets and multiply each sampled value by the appropriate engineering scale factor. A table of values will be accumulated for each train and recorded on a digital cassette tape. After returning from each field trip the digital cassettes will be entered into a master data base along with the appropriate key identifiers for further analyses.

Track Response Data. The following values are required from each wheel pass for further processing in digital format:

| <u>Measurement</u>     | <u>Data per Wheel Pass</u>   |
|------------------------|------------------------------|
| Vertical W/R Load      | Peak Value                   |
| Lateral W/R Load       | Plus or minus peak           |
| Tie Strain (Rail Seat) | Tensile or Compressive Peaks |
| Tie Strain (Center)    | Tensile or Compressive Peaks |
| Rail Clip Strain       | Tensile or Compressive Peaks |

Lateral and vertical loads must be retained as number sets (per wheel) for further processing of L vs. V, and L/V.

### 8.1 Data Formats

- (a) Mean Value. Mean values of peaks for each measurement shall be computed from the relationship

$$\bar{X} = \frac{1}{n} \sum_{i=1}^n D_i$$

where...  $x_i$  = peak data value under  $i_{th}$  wheel,

$n$  = total number of wheels in data set.

Mean value shall be tabulated along with standard deviation, number of wheels in the data set, run number and any other identifying information.

- (b) Standard Deviation. The standard deviation for each measurement shall be computed from the relationship

$$s = \sqrt{\sum_{i=1}^n (X_i - \bar{X})^2 / (n-1)}$$

- (c) Frequency-of-Occurrence Histogram. An example of a frequency-of-occurrence histogram is shown in Figure 8-1. These histograms shall be developed over the range and increments listed below in Table 8-1, with the vertical scale adjusted to provide convenience and good resolution:

TABLE 8-1. STATISTICAL DATA PROCESSING RANGE AND INCREMENT REQUIREMENTS

| Measurement         | Range           | Increments #     |
|---------------------|-----------------|------------------|
| Vertical W/R Load   | 0 to 60 kips    | 1.2 kips         |
| Lateral W/R Load    | -10 to +20 kips | 0.6 kips         |
| Tie Strain (Seat)   |                 |                  |
| Tensile Maximum     | *               | 10 $\mu\epsilon$ |
| Compressive Maximum | *               | 10 $\mu\epsilon$ |
| Tie Strain (Center) |                 |                  |
| Tensile Maximum     | *               | 10 $\mu\epsilon$ |
| Compressive Maximum | *               | 10 $\mu\epsilon$ |
| Rail Clip Strain    |                 |                  |
| Tensile Peak        | *               | 60 $\mu\epsilon$ |
| Tensile Minimum     | *               | 60 $\mu\epsilon$ |

\*To be determined from initial examination of data.

#Increments may be adjusted if necessary for specific data processing system.



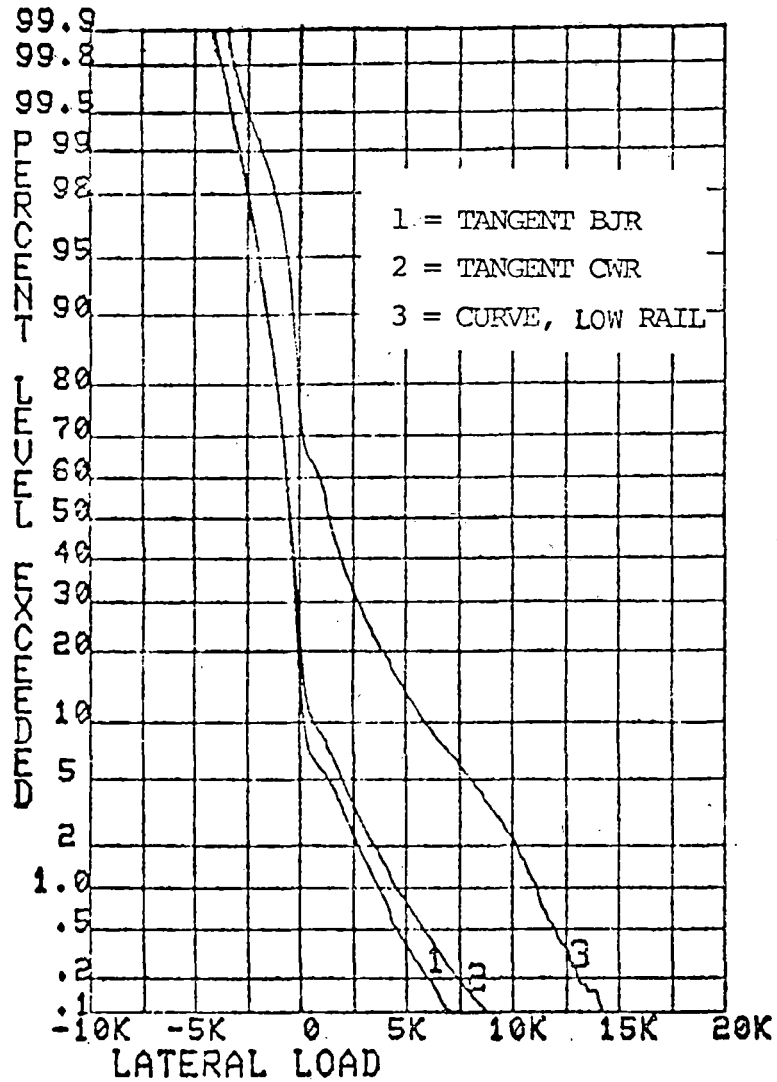

118651 128651 138651

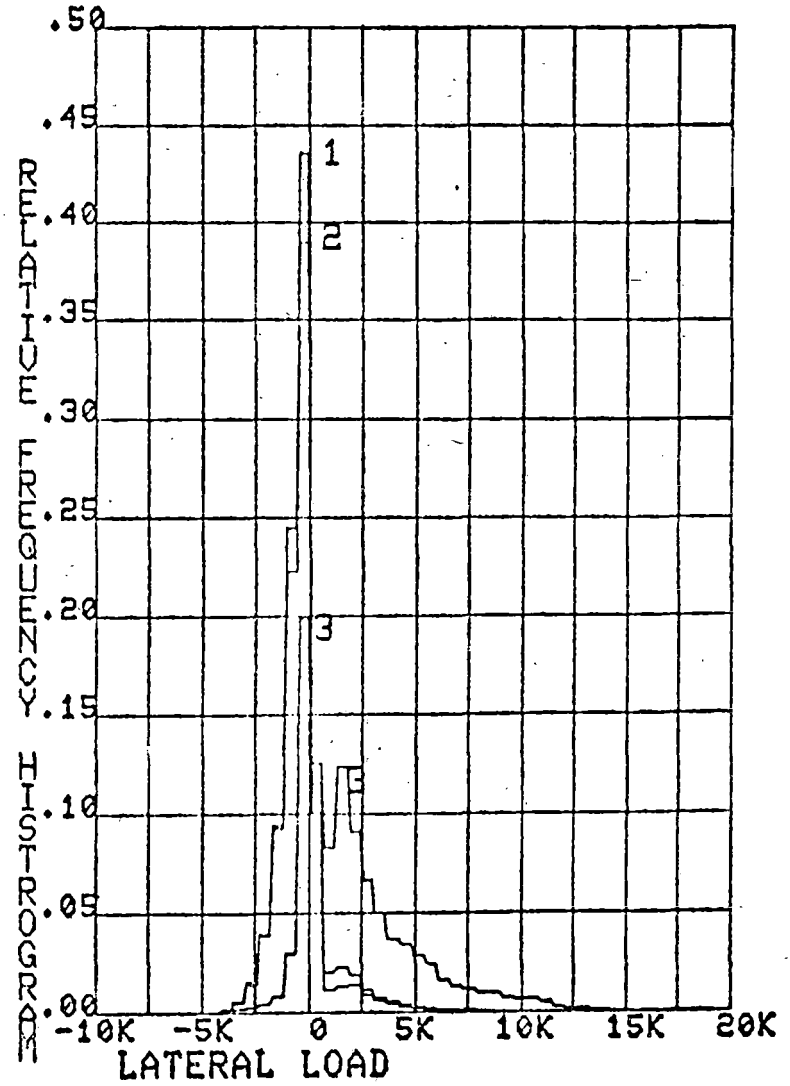

FIGURE 8-1. PEAK LATERAL W/R LOAD STATISTICS FOR ALL TRAFFIC, ALL SPEEDS, ALL MEASUREMENT SITES (0.6 KIP LOAD INTERVAL)

- (d) Cumulative Frequency-of-Exceedance Plot. An example of a frequency-of-exceedance plot, which is on the standard probability format, is shown in Figure 8-1. These plots are simply one minus the integration of the histogram over the given range.
- (e) Lateral vs. Vertical W/R Load Matrix. Frequency-of-occurrence numbers shall be developed in a two-dimensional matrix of lateral load vs. vertical load by 1.2-kip lateral increments and a 4.8-kip vertical increments, over the ranges given in (c) above.
- (f) Time-History Plots. Representative samples of each measurement set (configuration) shall be run out on oscillograph charts at the appropriate band-width (see Table 8-1) under several locomotive and heavy freight car wheels. Samples shall provide sufficient resolution on the time base to determine response frequencies (a chart speed from 4 to 10 inches per second is recommended), and sufficient resolution on the vertical scale for data analysis. Traces must be fully identified as to run number, channel, scale, etc.

Data analysis and format requirements are summarized in Table 8-2.

## 8.2 Acceleration Data Requirements

Rail and tie acceleration measurements are handled separately from the other track response measurements, and have distinct data reduction and formatting requirements. The recommended method for handling the acceleration data is to process it directly from the analog tape recordings, using a digital signal analyzer such as the Hewlett Packard Model 5420A, which provides a dual-channel capability.

TABLE 8-2. SUMMARY OF TRACK DYNAMIC RESPONSE MEASUREMENT  
DATA FORMAT REQUIREMENTS

| Measurement            | Data               | Analysis Formats             |
|------------------------|--------------------|------------------------------|
| Vertical W/R Load      | + Peak             | M, S, H, E, T <sup>(a)</sup> |
| Lateral W/R Load       | Max. (+ or -) Peak | M, S, H, E, L vs. V, T       |
| Tie Strain (Rail Seat) |                    | T                            |
|                        | Compression Peak   | M, S, H, E                   |
|                        | or Tension Peak    | M, S, H, E                   |
| Tie Strain (Center)    |                    | T                            |
|                        | Compression Peak   | M, S, H, E                   |
|                        | or Tension Peak    |                              |
| Rail Clip Strain       |                    | T                            |
|                        | Tension Maximum    | M, S, H, E                   |
|                        | or Tension Minimum | M, S, H, E                   |

- (a) M = mean value  
S = standard deviation  
H = frequency-of-occurrence histogram  
E = frequency of exceedance plot  
T = representative time history  
L vs. V = lateral versus vertical W/R load matrix.

The following specific data formats are required:

- (a) Auto Power Spectrum. Power spectral density plots shall be developed for each of the vertical acceleration measurements, averaging a sufficient number of wheels of the train to provide a good sample (50 to 100 wheels). Analysis bandwidth shall include 0-400 Hz and 0-1600 Hz for the rail, and 0-100 Hz, 0-400 Hz for the tie accelerations. Plots of both linear and log magnitude versus linear frequency shall be produced in hard copy.
- (b) Cross Power Spectrum. Cross power spectral plots shall be developed between rail and tie rail seat accelerations, and between each combination of pairs of tie vertical accelerations given in Table 8-3. Analysis bandwidths shall include 0-400 Hz and 0-1600 Hz for the rail/tie CPSD, 0-100 Hz and 0-400 Hz for tie/tie CPSD. Plots of log magnitude and phase shall be produced in hard copy.
- (c) Transfer Function. Transfer function plots shall be developed between rail and tie rail seat vertical accelerations. Analysis bandwidths shall include 0-400 Hz and 0-1600 Hz. Plots of log magnitude and phase shall be produced in hard copy.

Plots shall be produced on standard graph paper at least 8-1/2 x 11 inches in size for good resolution during analysis of plots. Acceleration data processing and formal requirements are summarized in Table 8-3.

TABLE 8-3. DATA PROCESSING AND FORMATS FOR TRACK VERTICAL ACCELERATIONS

| Vertical Acceleration<br>Measurement | Processing | Analysis<br>Bandwidth, HZ <sup>(1)</sup> | Required Plot Formats |        |             |
|--------------------------------------|------------|--|-----------------------|--------|-------------|
|                                      |            |  | Amplitude             | Phase  | Frequencies |
| (1) Rail Base                        | PSD        | 0-400, 0-1600                            | Linear, Log           |        | Linear      |
| (2) Tie (Rail Seat)                  | PSD        | 0-100, 0-400                             | Linear, Log           |        | Linear      |
| (3) Tie End                          | PSD        | 0-100, 0-400                             | Linear, Log           |        | Linear      |
| (4) Tie Center                       | PSD        | 0-100, 0-400                             | Linear, Log           |        | Linear      |
| (5) Rail/Tie (Rail Seat)             | CPSD, TF   | 0-400, 0-1600                            | Log                   | Linear | Linear      |
| (6) Tie (Rail Seat)/Tie Center       | CPSD       | 0-100, 0-400                             | Log                   | Linear | Linear      |
| (7) Tie End/Tie Center               | CPSD       | 0-100, 0-400                             | Log                   | Linear | Linear      |

(1) Analysis bandwidth may be adjusted as necessary for specific data processing system.

## 9. FAST TRACK PERFORMANCE DATA

Track performance data from FAST will be needed to compare with all of the measurements to be made at the revenue service test segments. Most of the data will be collected during the Phase II set of tests for which track construction is planned to start in the period from April to June of 1979. New ballast, concrete ties, fasteners and rail will be installed in portions of Sections 3, 17 and 22 of the FAST track. Section 22 will include both wood and concrete tie segments with construction identical to the new Northeast Corridor installations. New sets of experiments in the tie/fastener and ballast areas have been planned and are described in References [9-1] and [9-2].

Detailed descriptions of required data reductions appear in the previously mentioned test plans [9-1 and 9-2]. A specific request for data from these experiments will be directed to the Transportation Test Center with the concurrence of the contract monitor. Table 9-1 summarizes the required data.

TABLE 9-1. SUMMARY OF FAST TRACK PERFORMANCE DATA REQUIREMENTS

- (1) Data are to be requested for Sections 3, 17 and 22, beginning with the installation of new concrete and wood ties for the Phase II Tie/Fastener and Ballast Experiments.
- (2) Data should be reduced for all measurements at the frequencies requested in the Phase II measurement plans (References [9-1 and 9-2]).

| MEASUREMENT                       | DESCRIPTION   |
|-----------------------------------|---|
| 1. MAINTENANCE RECORDS            | <p>Two compilations of the FAST Track Inventory and Maintenance Data Listing, arranged in the following order:</p> <ul style="list-style-type: none"> <li>a. By track section (largest grouping)</li> <li>b. Within each track section, by maintenance subcode</li> <li>c. Within each maintenance subcode, arrange the two listings separately as follows: <ul style="list-style-type: none"> <li>Listing 1 - chronologically</li> <li>Listing 2 - by starting tie number</li> </ul> </li> </ul> |
| 2. TRAFFIC DATA                   | Begin with Phase II installation.   |
| a. Consist Definitions            | <p>The train consist for all runs, identified by car number</p> <p>Current A-end and B-end weights of all cars in the fleet</p>   |
| b. Tonnage accumulation           | Complete listing of tonnage accumulation in MGT vs. date  |
| 3. WHEEL/RAIL LOADS               | Probability densities, cumulative probability distributions, peak averages and extreme loads for all measurements   |
| a. Vertical                       |   |
| b. Lateral                        |   |
| 4. TIE STRAIN<br>(BENDING MOMENT) | <p>Cumulative probability distributions, probability densities, peak averages and extreme values</p> <p>Simultaneous load and tie strain time histories</p>   |

TABLE 9-1. (Continued)

| MEASUREMENT                      | DESCRIPTION  |
|----------------------------------|--|
| 5. RAIL/TIE ACCELERATIONS        | Analog tape records of simultaneously recorded accelerations on rail and tie                                     |
| 6. FASTENER STRAIN/LOAD          |  |
| a. Dynamic Strain                | Time histories of simultaneously recorded fastener strain and wheel/rail loads                                   |
|                                  | Load deflection plots - fastener stiffness   |
|                                  | Cumulative probability distributions for selected train passes   |
| b. Fastener Toe Load             | All toe load measurements  |
| 7. VERTICAL TRACK MODULUS        | Time histories of wheel/rail loads and track deflection for slow roll-by   |
|                                  | Results of any static measurements   |
| 8. BALLAST DENSITY               | Variation in density over width and depth of track, to the extent that this is measured.                         |
| 9. PLATE LOAD RESISTANCE         | Variation in ballast stiffness over width and depth of track   |
|                                  | All recorded load-deflection plots   |
| 10. BALLAST GRADATION            | Cumulative "percent finer than" plots  |
| 11. BALLAST MATERIAL PROPERTIES  | Complete tabulated data set for all measured properties  |
| 12. SUBGRADE PENETRATION TESTS   | Depth-vs.-penetration force plots, showing mean and range within test section                                    |
| 13. SUBGRADE MATERIAL PROPERTIES | Measured properties tabulated by test site, material and depth. Mean and standard deviation within each material |



TABLE 9-1. (Continued)

| MEASUREMENT                         | DESCRIPTION  |
|-------------------------------------|--|
| 14. MOISTURE READINGS               | Tabulations of all measurements by depth, material and data of measurement   |
| 15. TRACK GEOMETRY CAR MEASUREMENTS | Strip charts showing all deviations vs. track distance<br><br>Probability densities, cumulative probability distributions, and extreme values of measurements for selected runs at intervals of approximately 10 MGT |
| 16. SURVEY-TO-BENCHMARK             | Tabulated values of all <u>changes</u> in position within the designated test segments   |
| a. Vertical                         | Mean and standard deviation of STB movements within designated subsections   |
| b. Lateral                          | No. of exceedances of 4-in. spacing and 2.25° skew deviations, plotted for each test segment vs MGT  |
| c. Longitudinal                     |  |
| 17. TIE MOVEMENT                    | Tabulated values of all skew and spacing values calculated from measured data  |
| 18. RAIL CREEP                      | Tabulated values, mean and standard deviation, for each rail creep measurement zone  |
| 19. STATIC GAGE                     | Tabulated values, mean and standard deviation, within designated test subsections  |
| 20. GAGE FACE WEAR                  | Tabulated values, mean and standard deviation, within designated test subsections  |
| 21. TIE/FASTENER/INSULATOR/         | Complete summary listing of all measurement results, by tie number within the designated subsections   |

TABLE 9-1. (Continued)

| MEASUREMENT                      | DESCRIPTION   |
|----------------------------------|---|
| 22. TIE FACE AND TOP INSPECTIONS | Complete tabulated summary listing of all measurement results, by tie number within the designated test subsections                           |
| 23. RAIL CORRUGATION             | Compilation of results within each test subsection, showing tie number, wavelength and depth, and mean and standard deviation of measurements |

## REFERENCES

- [5-1] Selig, E. T., Yoo, T. S., and Panuccio, C. M., "Mechanics of Ballast Compaction, Vol I, Field Methods for Ballast Physical State Measurement," Interim Report to USDOT TSC, Cambridge, Massachusetts, DOT/TSC/1115. November, 1977.
- [5-2] Gaskin, P. N., and Raymond, G., "Contribution to Selection of Railroad Ballast," ASCE, Transportation Engineering Journal, Vol. 102, No. TE2, May, 1976.
- [5-3] Raymond, G., et al., "Characteristics of Acceptable Railroad Ballast," paper presented at the TRB meeting, Washington, D.C., January, 1977.
- [5-4] Selig, E. T., Chang, C. S., Adegoke, C. W. and Alva-Hurtado, J. E., "A Theory for Track Maintenance Life Prediction," final report to U.S. DOT Office of University Research, July 1978.
- [9-1] Dean, F. E., Ahlbeck, D. R., Kish, A., and Weber, J., "Concrete Tie and Fastener Performance Evaluation, Phase II (425 - 625 MGT)", Battelle Columbus Laboratories and Transportation Systems Center, December 1978.
- [9-2] Rixner, J. J. and Sluz, A., "FAST Experiment Plan for Ballast Replacement in Sections 17, 3 and 22", Haley & Aldrich and Transportation Systems Center, December 1978.

APPENDICES

APPENDIX A. APPARATUS AND RECOMMENDED PROCEDURES FOR  
IN-SITU BALLAST DENSITY MEASUREMENT (Ref. 1)

A.1 Apparatus

1. Surface Ring

The surface ring is the major constituent of the ballast density apparatus. It serves both as a guide for excavating the hole in the ballast and as lateral support for the upper portion of the membrane when water is placed in the lined hole.

The surface ring has either a circular shape with a 7 1/2-in. (19.1 cm) inside diameter (Fig. A-1) or an oval shape with a 7 1/2-in. (19.1 cm) width and a 13 1/2-in. (34.3 cm) length (Fig. A-2). Each has an upper section with a height of 4 in. (10.2 cm) and a lower section with a height of 2 in. (5.1 cm). A 1/8-in. (0.3 cm)-diameter O-ring is placed in the slot along the bottom surface of the upper section in order to prevent leakage of the water. The two sections are fastened firmly together by wing nuts on studs attached to the base plate and extending to the top plate.

2. Point Gauge

A point gauge provides an accurate measurement of the water surface depth below the top of the surface ring.

The point gauge consists of a 1-in. (2.54 cm)-long conical tip connected to a micrometer. The micrometer is fastened to an aluminum cross bar, which rests on top of the ring device (Fig. A-3).

3. Flexible Rubber Membrane

A thin membrane lining the hole in the ballast to contain the water for volume determination is clamped between the two ring sections. The degree of expandability of the membrane should be sufficient to conform to the ballast surface in the sampling hole. A very thin, 0.007-in. (0.018 cm) thick, high quality latex rubber sheet (dental dam) is recommended. For the circular ring, the sheet must be at least 30 in. (76 cm) by 30 in. (76 cm) in size; for the oval ring the sheet must be at least 30 in. (76 cm) by 42 in. (107 cm).

4. Water Volume Measuring Device

An electrically operated water volume measuring device very accurately meters water placed into the hole and then pumps it out again. It also serves as an immersion container for laboratory measurement of the displaced volume of

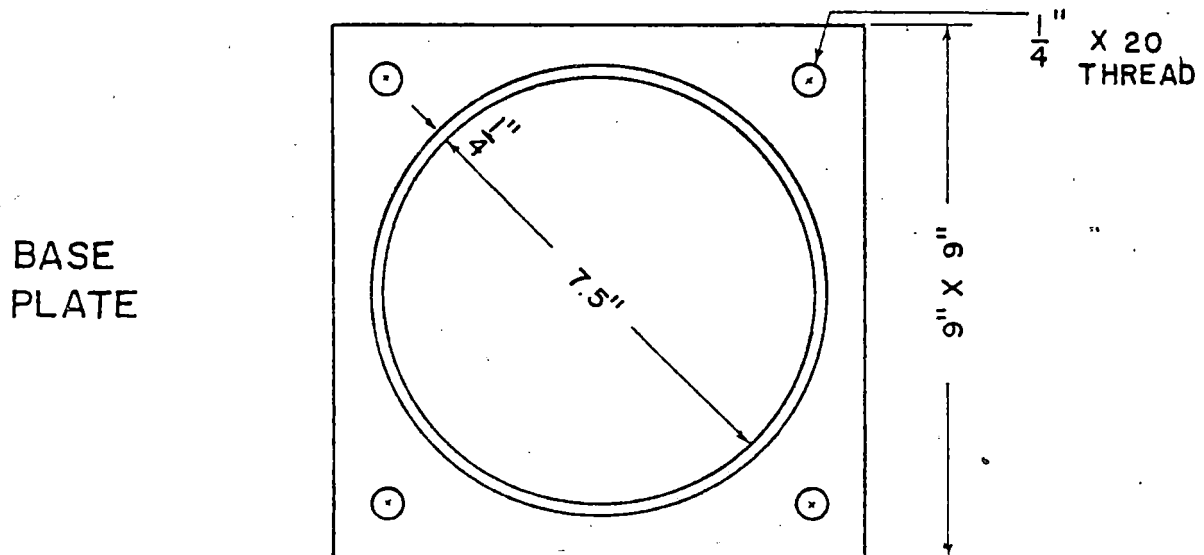
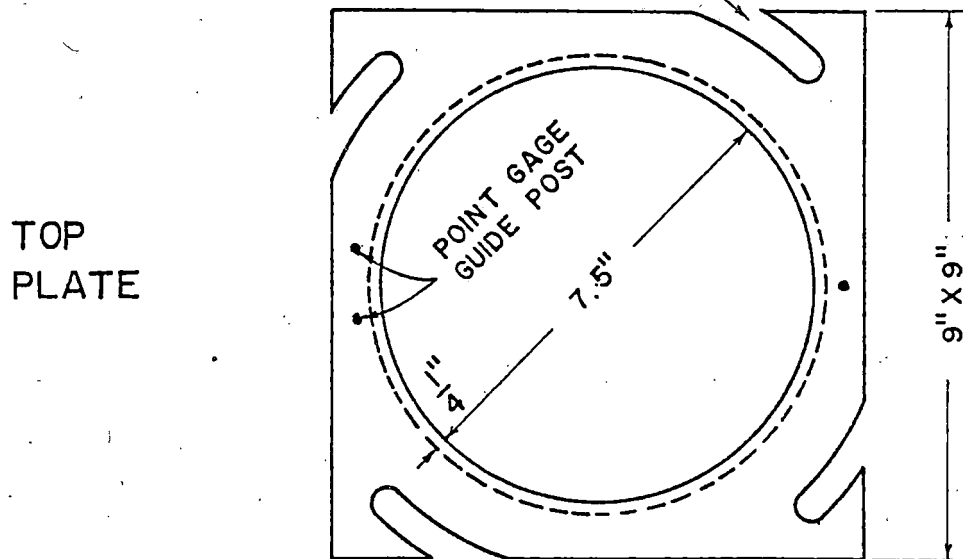
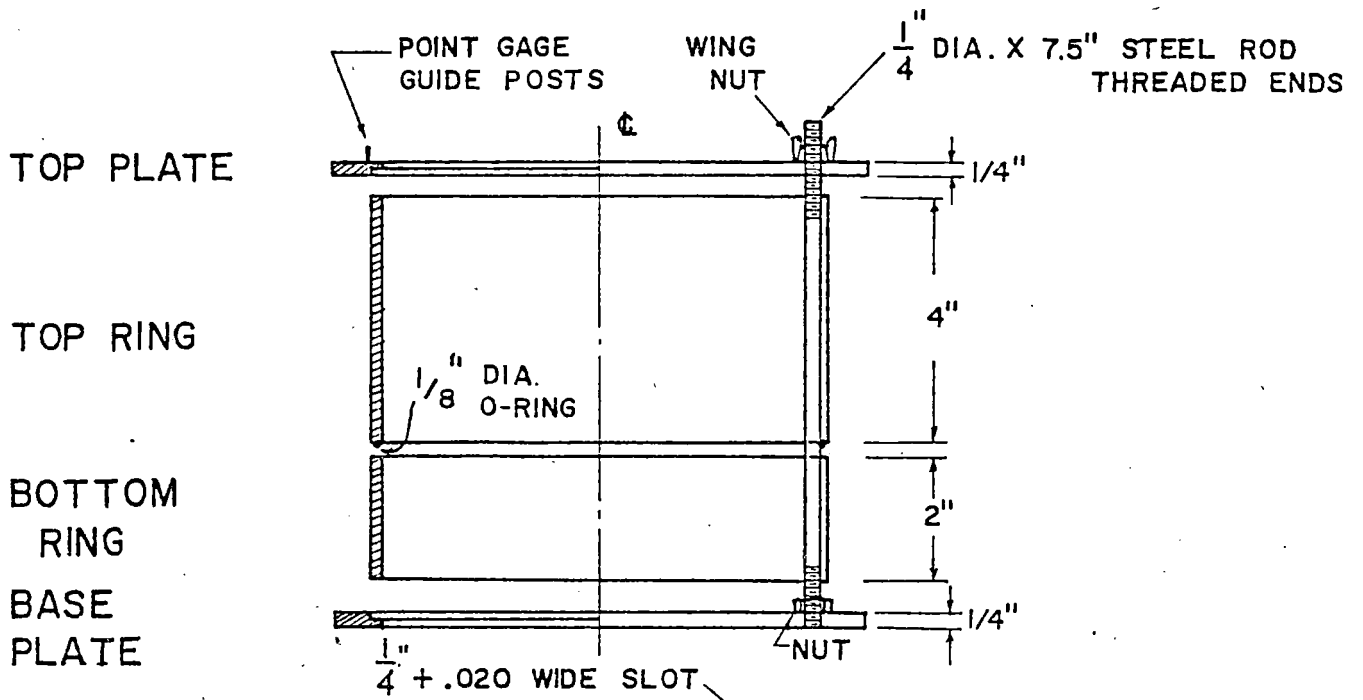

FIGURE A-1. CIRCULAR SHAPE SURFACE RING DEVICE

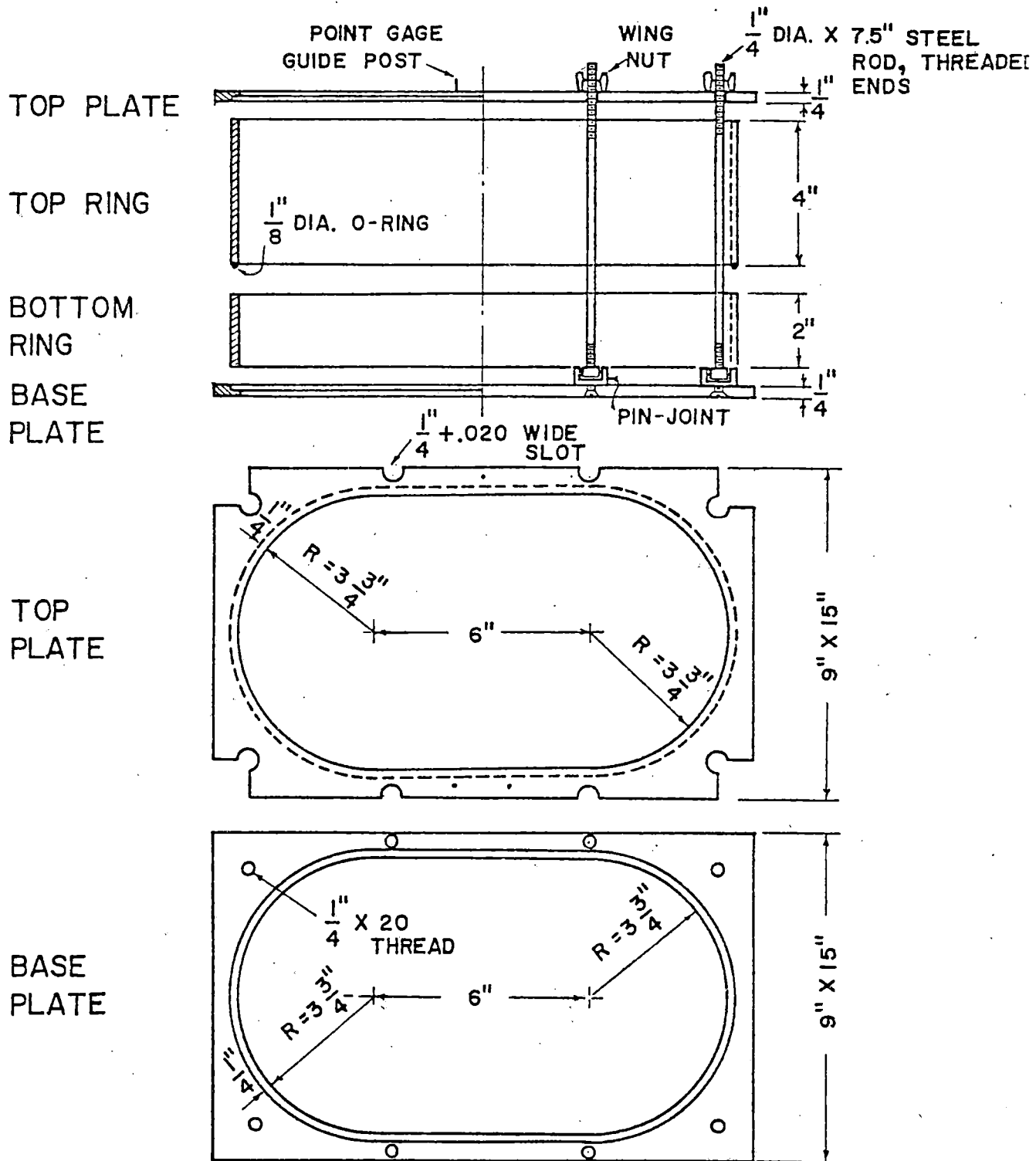

FIGURE A-2. OVAL SHAPE SURFACE RING DEVICE

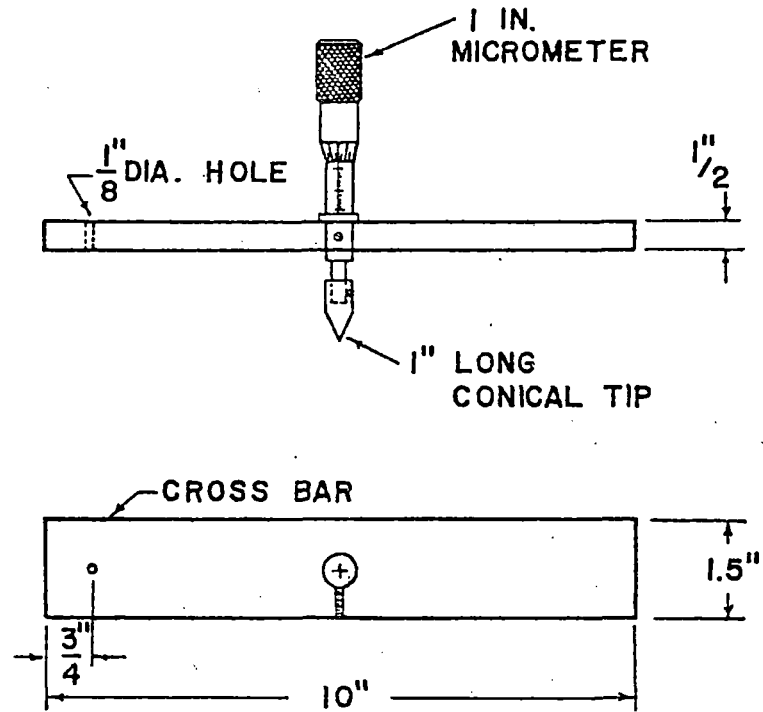

FIGURE A-3. POINT GAGE ASSEMBLY



solid ballast particles used in void ratio determination. This device is not essential to the test, but rather it makes the test easier and faster. Alternative methods of measuring water volume, such as the use of calibrated measuring containers, are acceptable.

The volume measuring device is basically a 7 1/2-in. (19.1 cm)-inside-diameter, 28-in. (71.1 cm)-high, water tank equipped with electrically operated pumps for mechanical water supply and return (Fig. A-4). The volume of water pumped into the sampling hole is monitored with a 24-in. (61 cm)-long satin chrome scale with 0.01-in. (0.025 cm) divisions, vertically mounted on an acrylic plastic float. A cross bar on the top of the water tank guides the floating scale and provides a reference point for differential reading of water depth in the tank.

#### 5. Hole Template

A template is used to apply a plaster of paris layer on the ballast surface to stabilize loose ballast particles around the hole and to provide smooth and flat base for the ring device. The plastic template has either a circular or an oval shape to fit the shape of the ring to be used (Fig. A-5). It has extended tips around the circumference to form locking slots for the base plate of the ring device. These locking slots prevent any accidental movement of the ring device during testing.

#### 6. Ballast Sample Basket

An acrylic container, with a #40 mesh screen bottom, is used to place ballast particles in the volume measuring device and retrieve them again when the volume of the ballast particles is measured for void ratio determination (Fig. A-6).

#### 7. Other Equipment

- a. A weighing scale accurate to 1 gm and with a capacity of 10 kg.
- b. One or two suitable water containers with a 5-gal (4.5 liter) capacity each.
- c. Sample bags.
- d. Plaster of paris and appropriate mixing pans and tools.

### A.2 Procedures

The following steps are followed to measure the in-situ ballast density using apparatus described in section A.1:

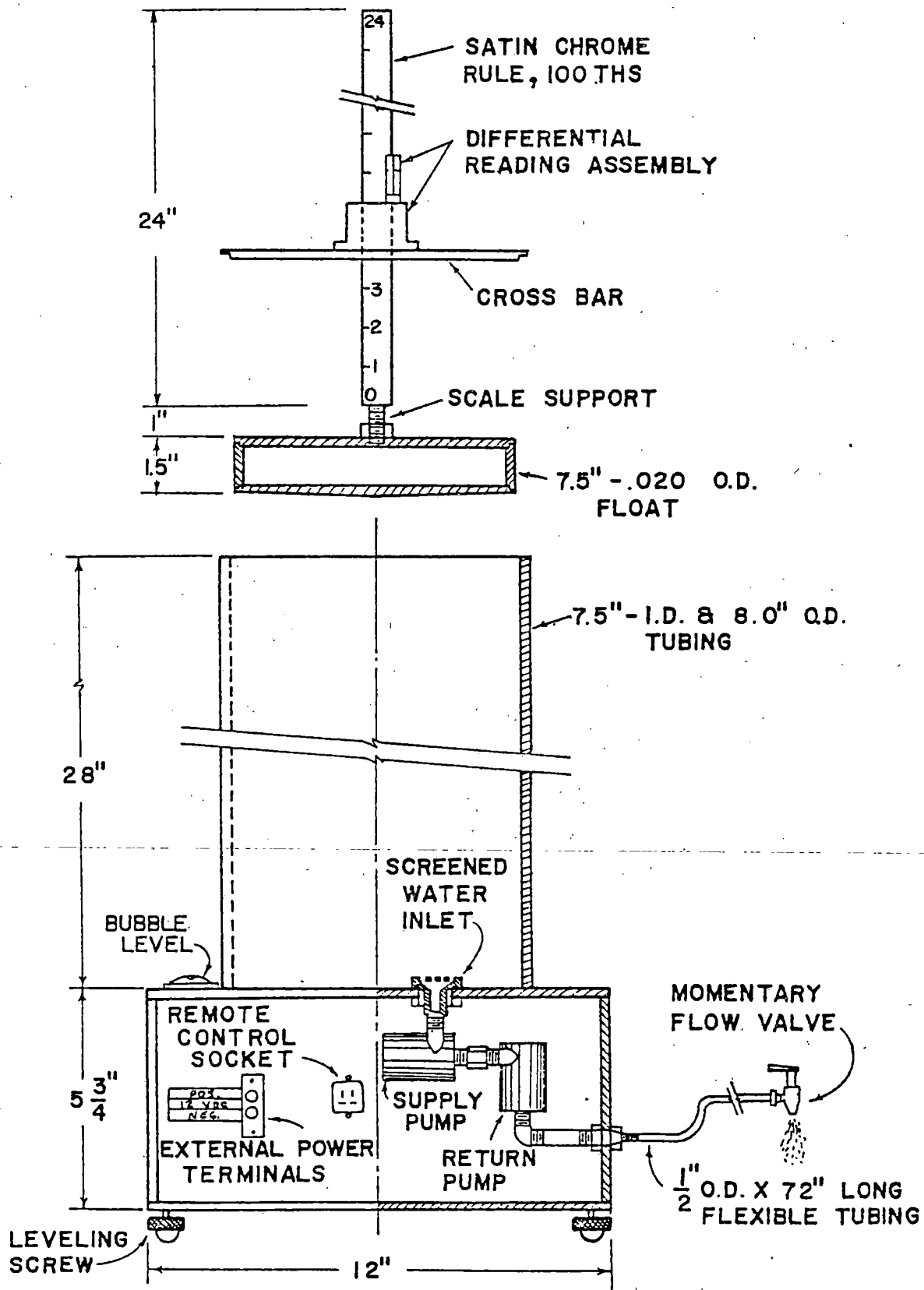
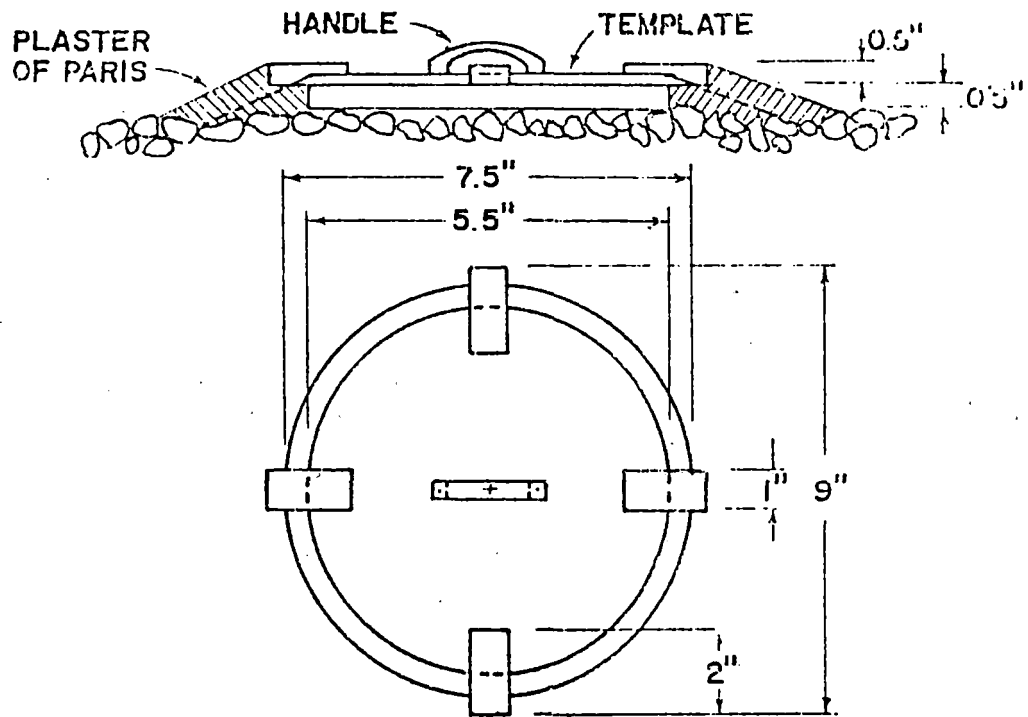
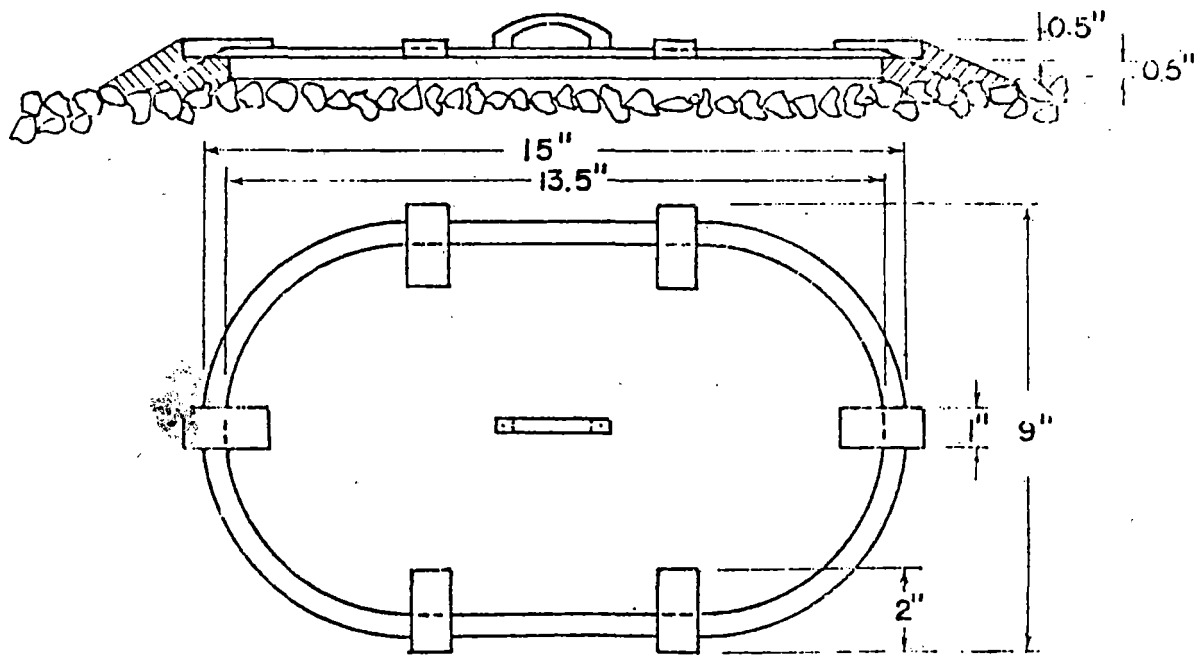

FIGURE A-4. WATER VOLUME MEASURING DEVICE



a) CIRCULAR SHAPE



b) OVAL SHAPE

FIGURE A-5. TEMPLATES FOR FORMING PLASTER OF PARIS BASE

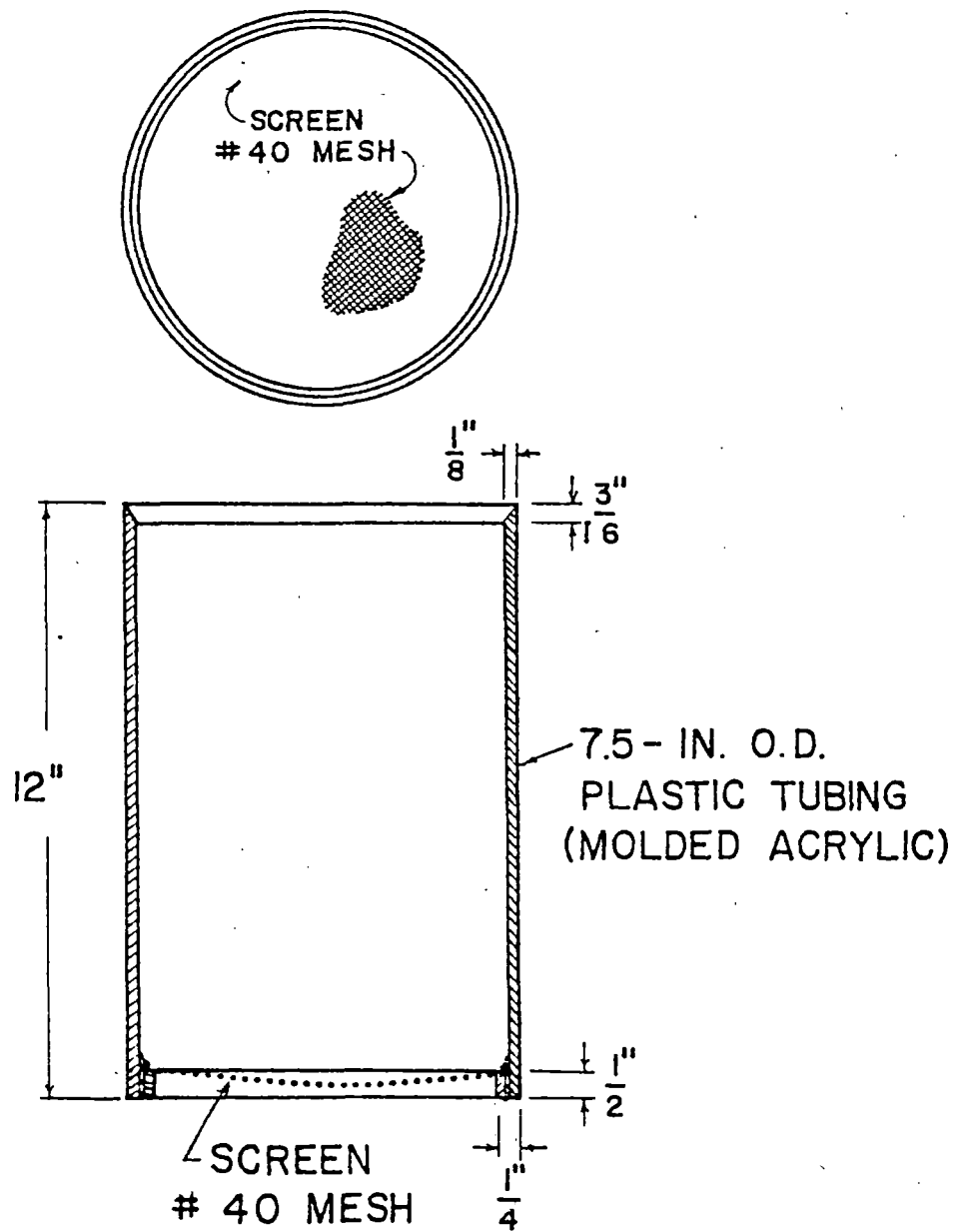

FIGURE A-6. BALLAST SAMPLE BASKET

1. Select the location to be tested, and remove ballast particles down to the top of the layer to be measured. Level off the exposed surface outside the test hole location by rearranging individual ballast particles without disturbing the ballast bed.
2. Seat the hole template on the prepared surface covering the ballast to be removed, and apply the plaster of paris mix around the circumference of the template (Fig. A-7a). Remove the template when the plaster of paris has hardened.
3. Seat the base plate of the ring device and the lower ring section on the prepared plaster surface. Be sure the base plate is properly seated in the locking slots.
4. Lay the rubber membrane over the bottom ring section. Allow enough slack so that the membrane can conform to the voids in the ballast surface within the ring when water pressure is applied (Fig. A-7b).
5. Place the upper ring section on top of the bottom section and securely tighten the fastening wing nuts (Fig. A-7c).
6. Fill the volume measuring tank with water, and check for any trapped air in the system by just pumping water back and forth. Record water temperature to check the effect of temperature changes on water volume during the testing period. Record the initial water depth after the floating scale is stabilized.
7. Supply water from the volume measuring device to fill the ring to 1 to 2 in. (2.5 to 5.1 cm) from the top edge of the upper ring section. Check for leaks through the membrane and through the seam between the lower and upper ring sections. Record the final water depth in the tank. The difference between this depth and the depth measured in Step 6 when multiplied by the cross sectional area of the tank gives the volume of water placed in the ring device.
8. Record the depth to the water surface in the ring device using the point gauge (Fig. A-7d).
9. Pump water out of the ring device. Then remove the upper ring and rubber membrane, taking care not to displace the measuring mold and not to damage the membrane.
10. Remove the ballast particles inside the ring by hand, being careful not to lose any fine particles in the sample and not to leave any particles that are moved during the excavation (Fig. A-7e). Extreme care should also be exercised not to disturb the remaining ballast particles.
11. Repeat Steps 4 through 8 (Fig. A-7f, g).

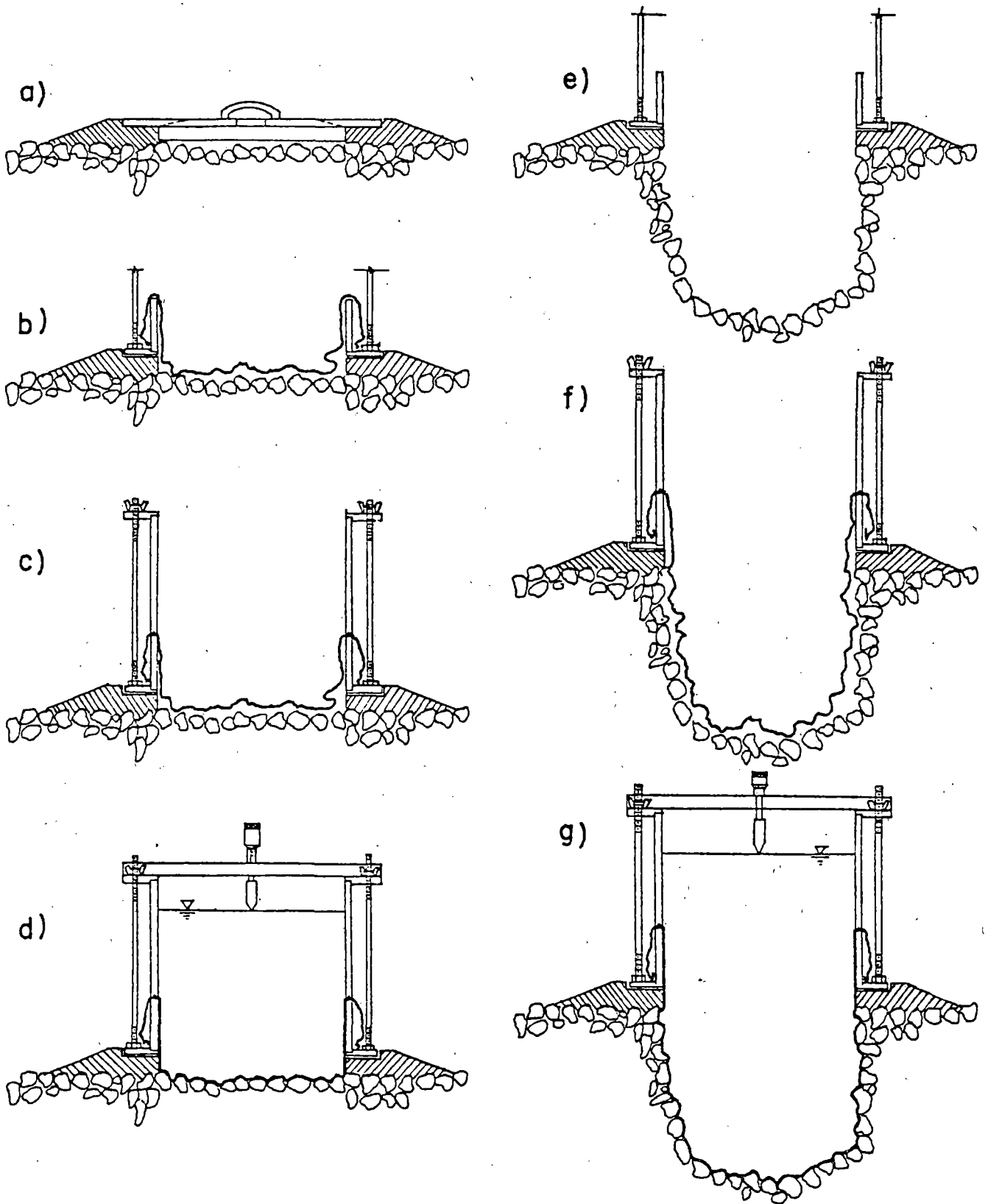

FIGURE A-7. STEPS IN MEASURING IN-SITU BALLAST DENSITY

12. Weigh the excavated ballast and record the weight. If the ballast is wet, seal the sample immediately until it can be oven dried to determine the moisture content.

13. Calculate the volume of the hole ( $V_h$ ) from which the ballast particles were removed as follows:

$$V_h = (V_2 + D_2 A_t) - (V_1 + D_1 A_t) ,$$

where  $V_1$  = volume of water in ring device before hole is excavated,

$V_2$  = volume of water in ring device after hole is excavated,

$D_1$  = depth from top of ring device to water surface before hole is excavated,

$D_2$  = depth from top of ring device to water surface after hole is excavated, and

$A_t$  = cross-sectional area of water in ring.

14. Calculate the in-situ ballast density ( $\gamma_n$ ) by dividing the ballast weight by the sample hole volume.

### A.3 Void Ratio and Sieve Procedures

The following procedures are used to determine in-situ void ratio and ballast particle size distribution:

1. Fill the water volume measuring tank up to about mid-height, and check for any trapped air.

2. Immerse the ballast basket into the water, and record the initial water depth after the floating scale has stabilized.

3. Re-weigh the entire ballast sample removed in forming the hole.

4. Place the ballast samples into the basket while keeping the basket inside the tank. Be careful not to lose any ballast particles.

5. Fully immerse the basket with ballast particles and stir up the water several times to extract any air bubbles trapped between ballast particles.

6. Record the final water depth when the floating scale has stabilized.

The change in water depth multiplied by the tank cross-sectional area is the apparent volume of ballast particles. This volume will be in error by the amount of water absorbed by the ballast particles after immersion. The absorption depends on the material composition as well as the amount of water already in the particles. In many cases, even if the ballast is dry, the water absorption by the particles will be small enough to neglect.

7. With the sample still inside, drain the water out of the device through

a #200 washing sieve to collect the minus #40 particles.

8. Flush the tank by adding more water and pumping it out at a fast rate to remove any fine particles in the system, including those adhering to the coarse particles. Continue until the draining water is clean. Occasional stirring up of the ballast particles will help.

9. Remove the ballast particles, both in the basket and in the #200 washing sieve, and oven dry.

10. Measure the oven-dry weight of the samples, and perform the sieve analysis by conventional procedures.

11. Calculate the in-situ void ratio ( $e$ ) by

$$e = \frac{V_h - V_s}{V_s}$$

where  $V_h$  = volume of sample hole, and

$V_s$  = volume of ballast particles.

12. Estimate the particle specific gravity ( $G_s$ ) by

$$G_s = \frac{(1 + e)\gamma_d}{\gamma_{wet}}$$

where  $e$  = measured void ratio,

$\gamma_d$  = measured dry ballast density, and

$\gamma_{wet}$  = unit weight of water.

Compare the above calculated specific gravity with the specific gravity measured according to ASTM C-127.



APPENDIX B. APPARATUS AND RECOMMENDED REFERENCE DENSITY TEST  
FOR BALLAST MATERIALS (Ref. 1)

B.1 Apparatus

1. Compaction Mold

The compaction mold has an internal diameter of 12 in., and a height of 12 in. (Fig. B-1b). The volume is 0.785 cu ft.

2. Compaction Hammer

Compaction is accomplished with a manually-operated impact hammer (Fig. B-1a) having a 2 3/4-in.-diameter circular face, tipped with a rubber cylinder and weighing 7.8 lb. The rammer is equipped with a suitable guide sleeve to control the height of drop to a free fall of 17 in. above the elevation of the surface of the ballast sample. The guide sleeve has at least four vent holes not smaller than a 3/8-in. diameter, spaced 90 degrees apart and 3/4 in. from each end and provides sufficient clearance that free fall of the rammer shaft and head will not be restricted.

3. Volume Measuring Devices

a. Probe

The probe method for ballast volume measurement (Fig. B-2b) uses a metal rod of 3/4-in. diameter and 8-in. length, graduated in 1 mm divisions. A 12-in.-diameter plate with 33 probe holes uniformly distributed over the entire section area is used to locate the position of probe measurement.

b. Cover Plate

A rigid, 12-in.-diameter plate fitting into the compaction mold with a slight clearance is used in an alternative method of volume determination (Fig. B-2a). On the top of the plate, a handle and at least four vent holes having 3/8-in. diameter and spaced 90 deg. apart have to be provided.

c. Rubber Membrane

A membrane is used for the volume determination by water replacement (Fig. B-2c). The membrane should be very thin and have satisfactory expandability. A 0.007-in.-thick rubber sheet is recommended.

4. Supporting Equipment

- a. A balance or scale of at least 20 kg capacity, sensitive to 0.1 gm.
- b. A container of 1 cu ft capacity for water.
- c. Ruler, sample pan, scoop, and graduated cylinder.

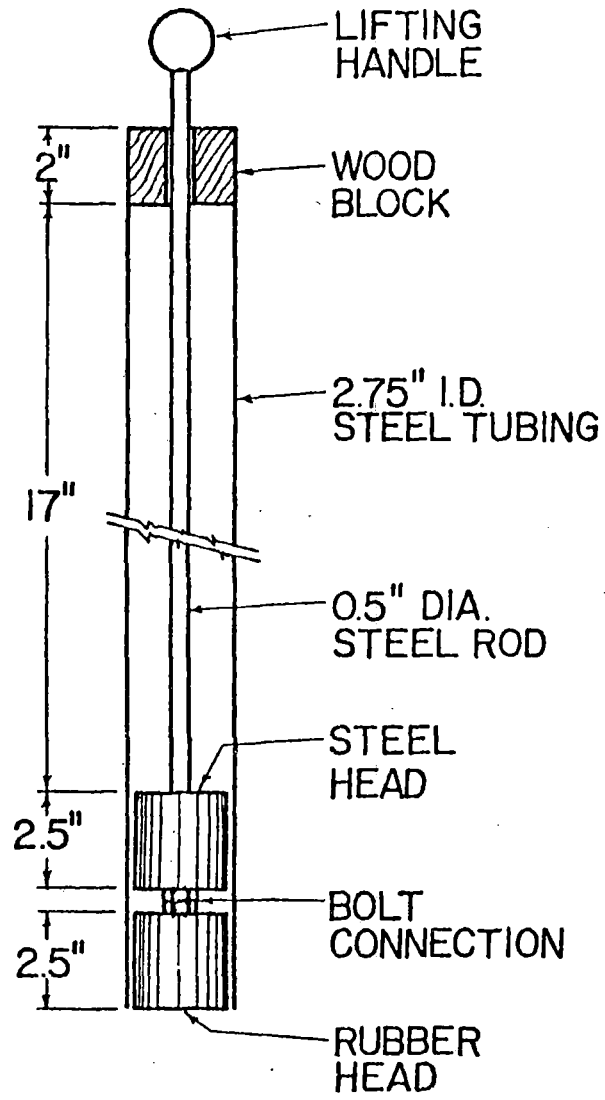

a) COMPACTION HAMMER

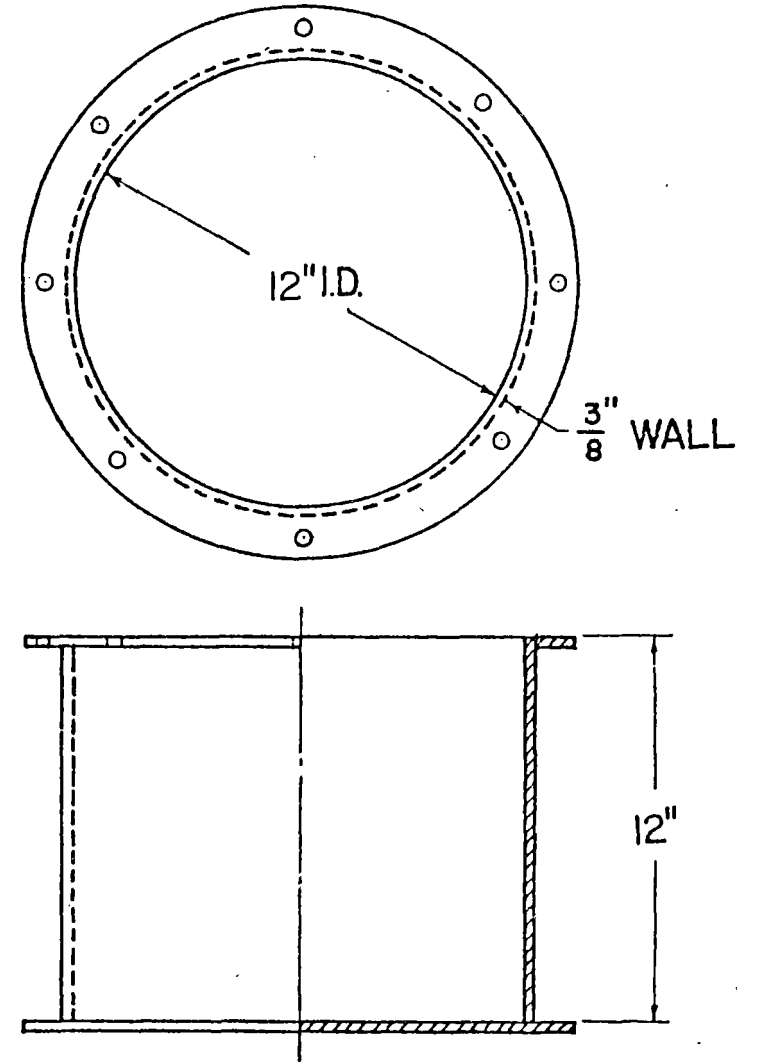

b) COMPACTION MOLD

FIGURE B-1. REFERENCE DENSITY APPARATUS

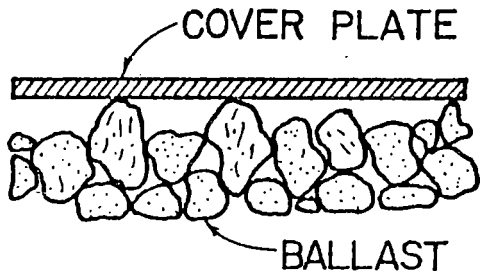

a) PLATE COVER METHOD

FIGURE B-2.

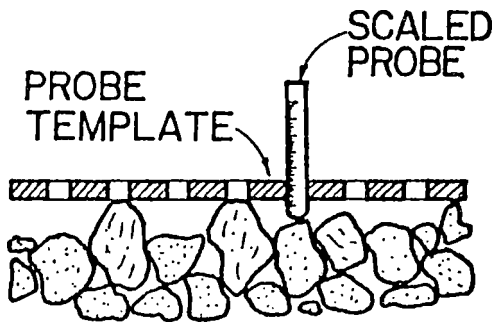

b) PROBE METHOD

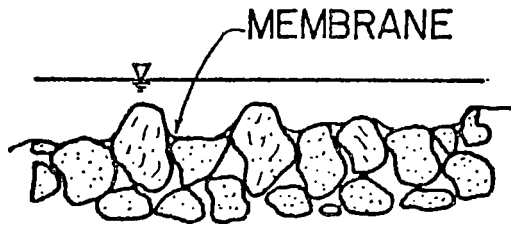

c) WATER REPLACEMENT METHOD

METHODS OF SAMPLE VOLUME DETERMINATION

## B.2 Test Procedures for Uncompacted Samples

1. Select a representative sample of about 1 cu ft. Then oven-dry the sample and let it cool.
2. Thoroughly mix the prepared sample, using a scoop.
3. Loosely place the ballast into the sample container in a uniform manner by gently pouring the ballast from the scoop with a minimum height of fall. Move the scoop in a spiral motion from the outside of the container toward the center to form a uniform density without particle segregation. Continue this process until the container is approximately 80% full.
4. Level the surface of the ballast in the container by filling any large voids and by removing any particles which project out too much.
5. Measure the volume of the ballast sample in the container, using the volume determination procedures described in part B.4 of this appendix.
6. Remove and weigh the ballast in the container.
7. Repeat this test at least once more. The average of all of the tests run is used as the bulk density of the uncompacted sample.

## B.3 Test Procedures for Compacted Samples

1. Re-use the sample from part B.2. Thoroughly mix the sample, using a scoop.
2. Loosely place the ballast into the sample container in a uniform layer of approximately 4 in. thick, by gently pouring the ballast from a scoop with a minimum drop height. Move the scoop in a spiral motion from the outside of the container toward the center to form a uniform layer without particle segregation.
3. Compact the loose layer of ballast by delivering a specified number of blows from the impact hammer. For each blow, allow the rammer to fall freely from a height of 17 in., and evenly distribute the blows over the surface of the sample. The suggested number of compaction blows are either 10, 20, or 40 per layer.
4. Repeat steps 2 and 3 for the next two layers. When completed, the sample should fill about 80% of the container depth.
5. Level the surface of the ballast in the container by filling any large voids and by removing any large particles which project out too much.
6. Measure the volume of the ballast sample in the container, using

volume determination procedures described in part B.4.

7. Remove and weigh the ballast sample in the container.

8. At least two tests should be made for each compactive effort. The average of the tests performed is taken as the bulk density of the compacted ballast for the particular compactive effort.

#### B.4 Sample Volume Determination

Three alternative methods are provided to measure the volume of the ballast sample in the container when the container is filled to about 80% of its volume. These are designated the plate cover method, the probe method, and the water replacement method (Fig. B-2).

##### 1. Plate Cover Method

a. A cover plate is placed on the top surface of the sample in the mold, and the distance from the top edge to the plate cover is measured in at least four positions equally spaced apart along the circumference of the mold.

b. The average height of the ballast sample in the mold is obtained by subtracting the average distance measured in step a. plus the plate thickness from the inside depth of the mold.

c. The volume of the ballast sample is calculated as the average height of the sample times the inside cross-sectional area of the mold.

##### 2. Probe Method

a. A probe plate with guide holes is firmly set on the top of the mold.

b. The distance from the bottom surface of the plate to the ballast particle surface directly beneath the hole location is measured by inserting the probe through each probe hole.

c. The average height of the sample in the mold is obtained by subtracting the average distance determined in step b. from the inside depth of the mold.

d. The volume of the sample is equal to the average height of the sample times the cross-sectional area of the mold.

##### 3. Water Replacement Method

a. A plastic membrane is laid loosely over the top surface of the ballast sample so that it is in as close contact as possible with the inside of the mold and the ballast surface.

b. The depression in the membrane is filled with water to within 1 or 2 in. from the top of the mold.

c. The volume of water added and the distance from the top edge of the mold to the water surface are measured in at least four positions equally spaced apart along the circumference of the mold.

d. The unfilled volume between the top edge of the container and the ballast surface is determined from step c., and then the volume of the ballast sample in the container is obtained by subtracting this volume from the container volume.

## B.5 Calculations

### 1. Compactive Effort and Density

Calculate the compaction effort and bulk density of the compacted ballast sample for each trial as follows:

$$E = \frac{3W_r DN}{V_c} \quad , \quad (B-1)$$

and

$$\gamma_{pr} = \frac{W_s}{V_{cpr}} \quad , \quad (B-2a)$$

$$\gamma_{pc} = \frac{W_s}{V_{cpc}} \quad , \quad (B-2b)$$

$$\gamma_{wr} = \frac{W_s}{V_{cwr}} \quad , \quad (B-2c)$$

where

$E$  = compacting effort (ft-lb/cu ft),

$\gamma_{pr}$ ,  $\gamma_{pc}$ ,  $\gamma_{wr}$  = bulk density of a ballast sample obtained from using the probe method, the plate cover method, or the water replacement method, respectively (lb/cu ft),

$V_{cpr}$ ,  $V_{cpc}$ ,  $V_{cwr}$  = Volume of a ballast sample determined from using the probe method, the plate cover method, or the water replacement method, respectively (cu ft),

$W_s$  = weight of sample (lb),

$W_r$  = weight of hammer (lb),

D = free fall distance of hammer (ft),  
N = number of blows per layer,  
 $V_c$  = ballast sample volume in container corrected for  
container boundary effects (cu ft).

## 2. Ultimate Density

The sets of values of bulk density and compactive effort from the reference density test are plotted in the form given by Fig. B-3. The data are assumed to fit the hyperbolic form of Fig. B-3a which may be plotted in linear form using the coordinates of Fig. B-3b. A straight line is fit through the points in Fig. B-3b, either by eye or least squares curve-fitting methods. The ultimate density is calculated by the relationship

$$\gamma_{ult} = \frac{1}{b_1} + \gamma_0 \quad , \quad (B-3)$$

where

$b_1$  = slope of the line in Fig. B-3b,

$\gamma_0$  = uncompacted density when  $E = 0$ .



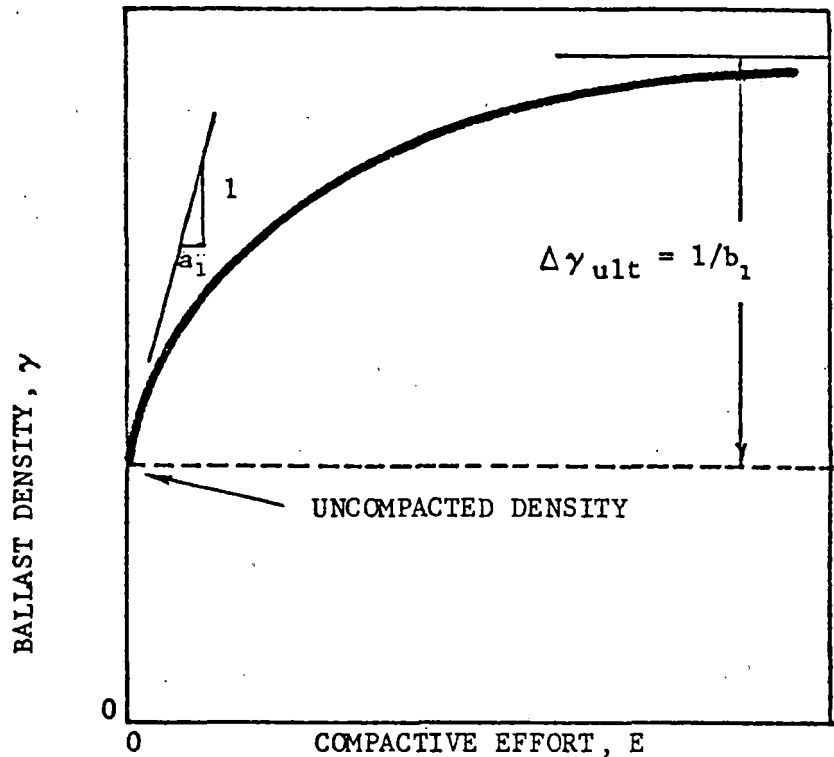

a) Hyperbolic Plot

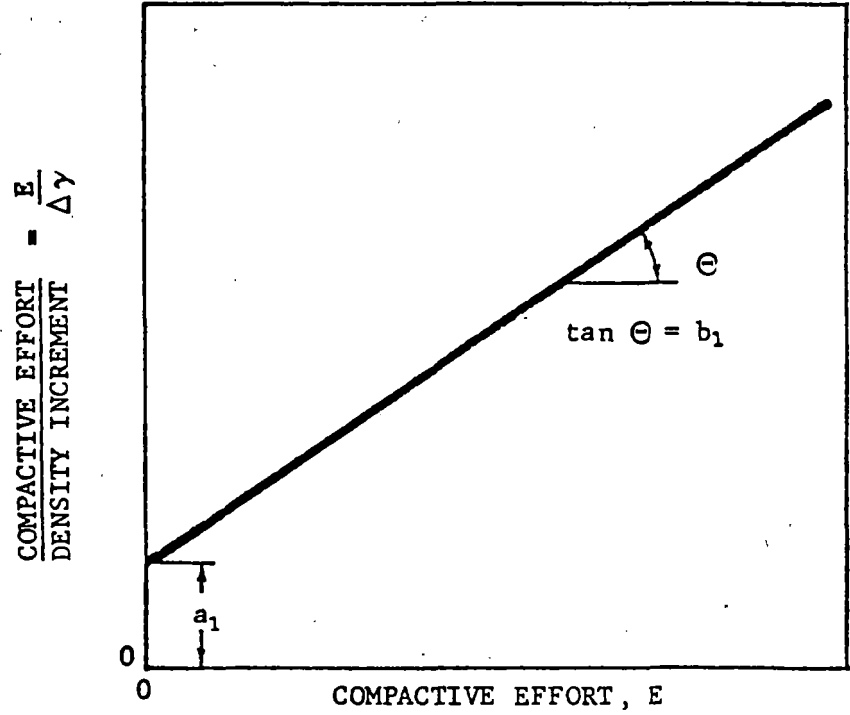

b) Transformed Plot

FIGURE 3.5. REPRESENTATION OF RELATIONSHIP BETWEEN DENSITY AND COMPACTIVE EFFORT

APPENDIX C. APPARATUS AND RECOMMENDED PROCEDURES  
FOR FIELD PLATE LOAD TEST (Ref. 1)

C.1 Apparatus

1. Load System

The assembled apparatus for the plate load test is shown in Fig. C-1. Each component will be described in detail and its function will be explained in this appendix. The presentation is subdivided into the two categories representing the two main components: 1) the load system including the reaction frame, hydraulic jack and electrical load cell, and 2) the deformation system including a mechanical dial gage, electronic displacement transducer and supporting apparatus.

a. Load Bearing Plate

A circular steel bearing plate (Fig. C-2) having a 1-in. (2.54 cm) thickness and a 5-in. (12.7 cm) diameter is used to apply the load to the ballast. The plate is seated on a thin layer of plaster of paris covering the ballast surface at the test spot. The plaster ensures a level plate and distributes the load more uniformly over the ballast surface. The bearing plate has a hole recessed in the center that is 1-9/16 in. (4.0 cm) in diameter and 3/16 in. (0.48 cm) deep to receive the displacement reference block.

b. Displacement Reference Block

A displacement reference block, seated in the recessed hole on the load bearing plate, establishes a reference point for measuring the average plate vertical displacement.

The displacement reference block is a partially slotted steel cylinder of 1-1/2-in. (3.8 cm) diameter and 2-3/8-in. (6.0 cm) height (Fig. C-3). The lower section which is 1-1/2-in. (3.8 cm) high, contains a 5/16-in. (0.8 cm) wide slot 1 in. (2.54 cm) deep. At midheight of this section, a 1/8 in. (0.32 cm) diameter and 1-1/2-in. (3.8 cm) long brass rod is press fit through a hole, which is perpendicular to the slot and traverses through the exact center point of this lower section. The brass rod is called the deformation reference pivot. The upper section, which is 7/8 in. (2.2 cm) high, is firmly fastened to the lower section by four 1/8-in. (9.32 cm) diameter countersunk flat head screws. The top surface of the upper section is

machined to a concave shape for seating the load cell.

c. Load Cell

An electrical load cell gives a continuous reading of the load applied to the ballast during cycles of loading and unloading. The load cell must have sufficient capacity for measuring the maximum expected applied load (10,000 lb or 4500 kg). Input voltage to the load cell is supplied by an appropriate power source and the output signals are recorded on the Y-axis of a compatible X-Y recorder.

The load cell is rigidly fixed to the moving piston of the hydraulic load jack in coaxial alignment. The length and diameter of the load cell must be such that the unit will not interfere with free movement within the load jack assembly support frame. The load cell used with this apparatus is shown in Fig. C-4.

d. Hydraulic Load Jack

The hydraulic load jack is used to apply a vertical load to the bearing plate. The piston and moving head may be advanced or retracted at the proper deformation rate by either a manually or an electrically operated hydraulic pump. The hydraulic pump is equipped with a calibrated fluid pressure gage to visually indicate the magnitude of the applied load and also to serve as a check on the load response of the load cell. The load jack, hydraulic pump and the attached hoses and connections must have sufficient capacity for applying the maximum desired load to the ballast. The load jack used with this apparatus is shown in Fig. C-5.

The upper fixed end of the load jack is fitted with an appropriately sized steel base plate with a hemispherically shaped bearing tip protruding from the free end of the base plate and located at the center of this plate. This bearing tip allows small rotations of the hydraulic load jack during testing or small misalignments during the assembly of the components. The bearing tip is fastened by a screw and set into a counter sunk hole in the bottom of a thrust plate (Fig. C-7) which is a portion of the load instrumentation support and reaction frame.

e. Spacer Cylinder

A spacer cylinder (Fig. C-6) is inserted between the load cell and the moving head of the hydraulic jack in order to lengthen the assembly to reach the ballast at the bottom of a tie. The spacer is composed of a 6-in.

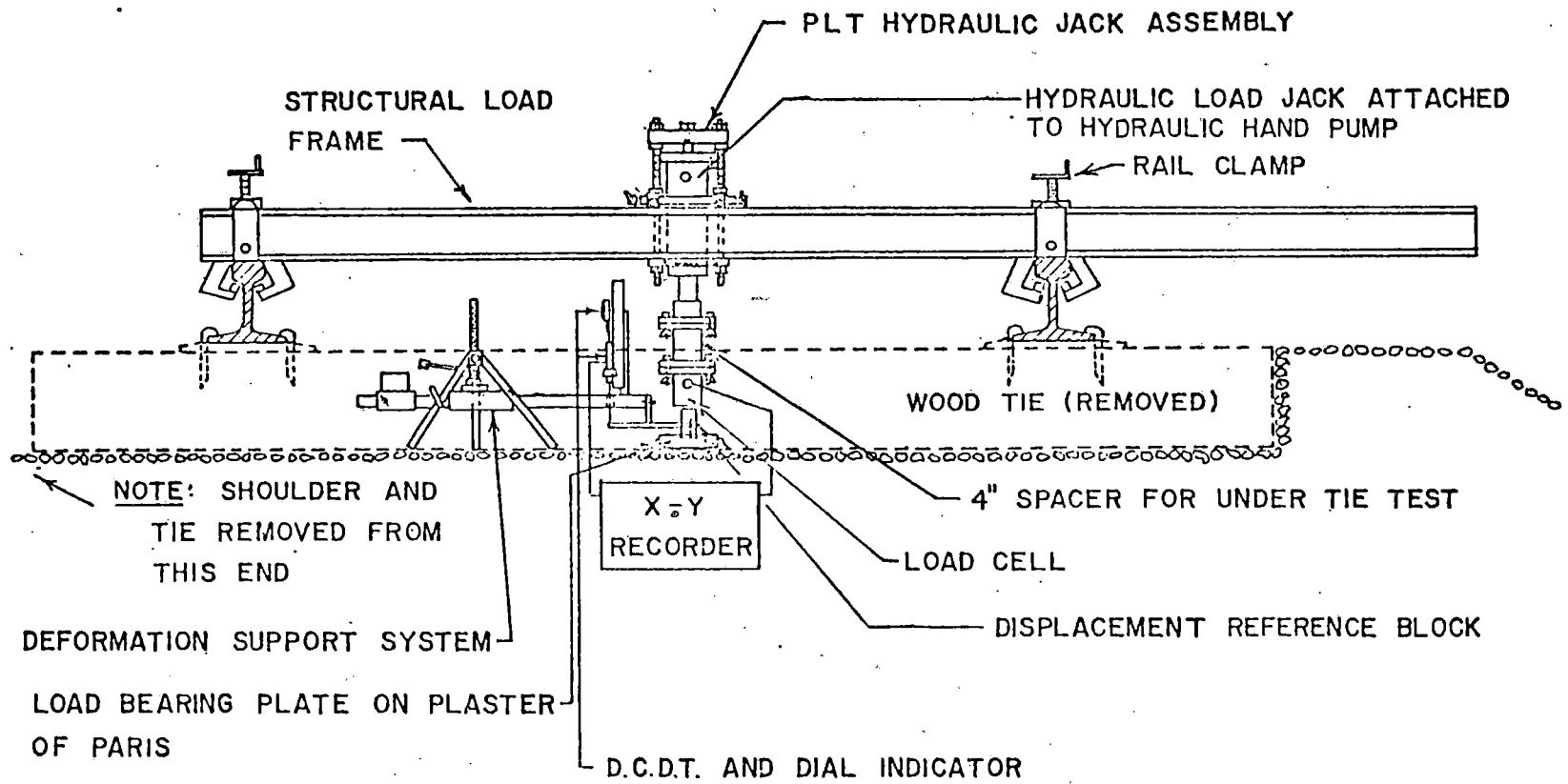
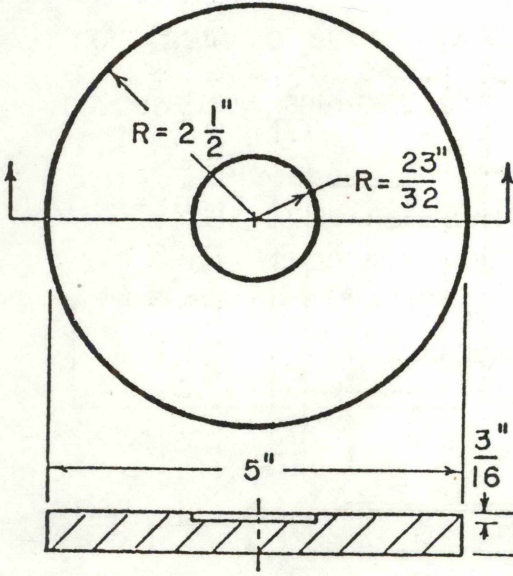

FIGURE C-1. ASSEMBLED PLATE LOAD TEST APPARATUS

C-4



TOP VIEW

SIDE VIEW

FIGURE C-2. LOAD BEARING PLATE

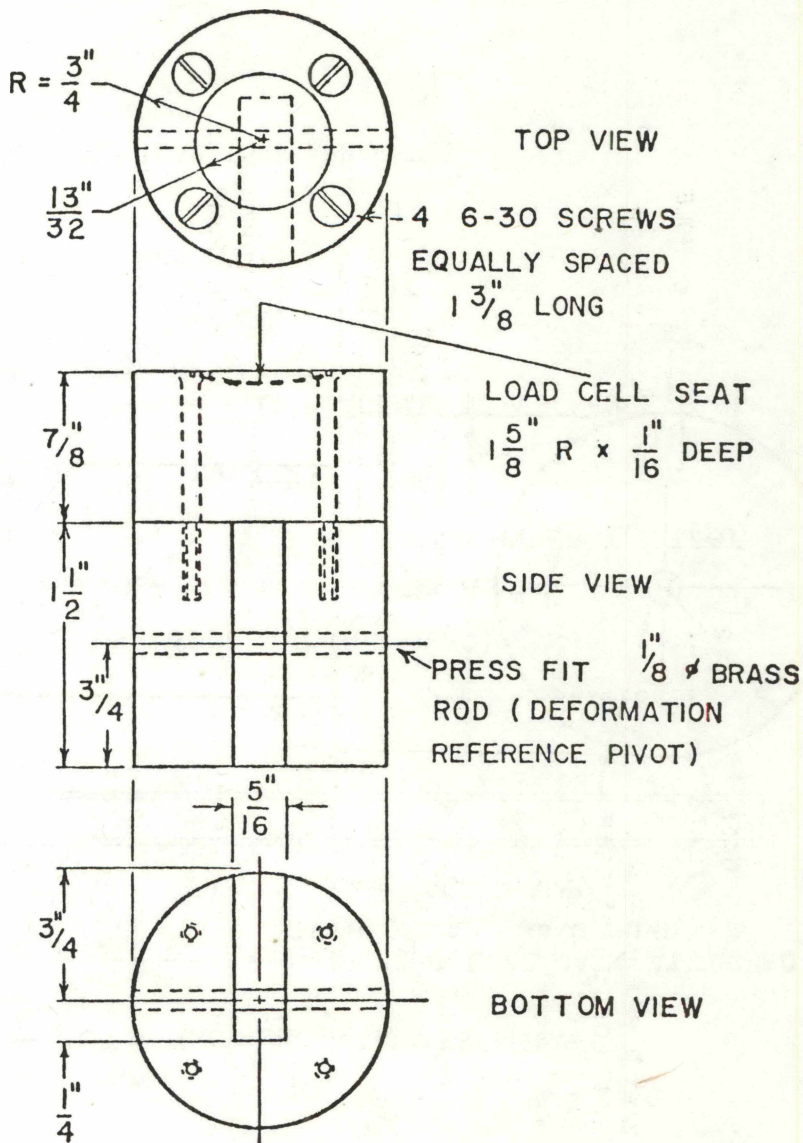

FIGURE C-3. DISPLACEMENT REFERENCE BLOCK

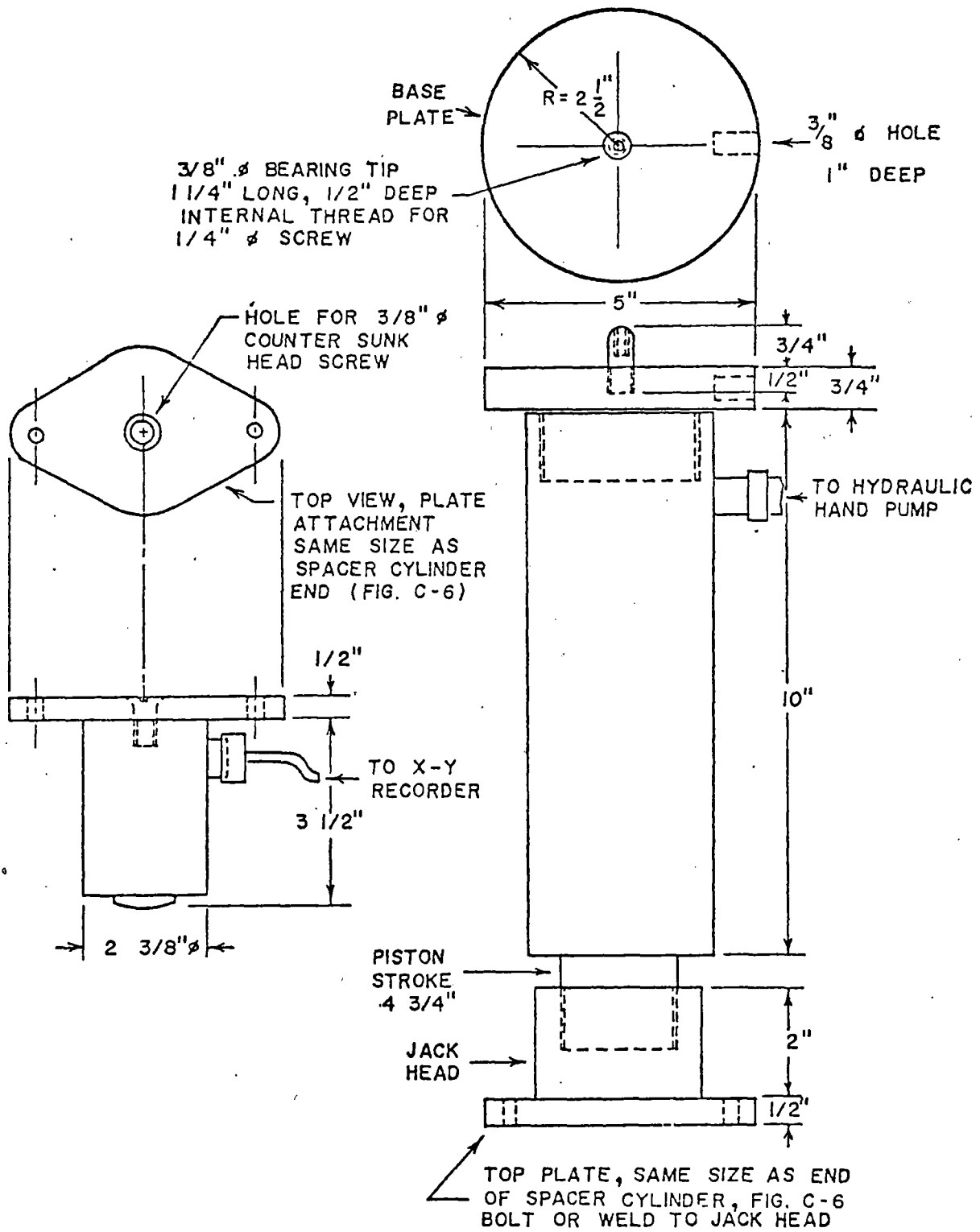

FIGURE C-4. LOAD CELL

FIGURE C-5. HYDRAULIC LOAD JACK

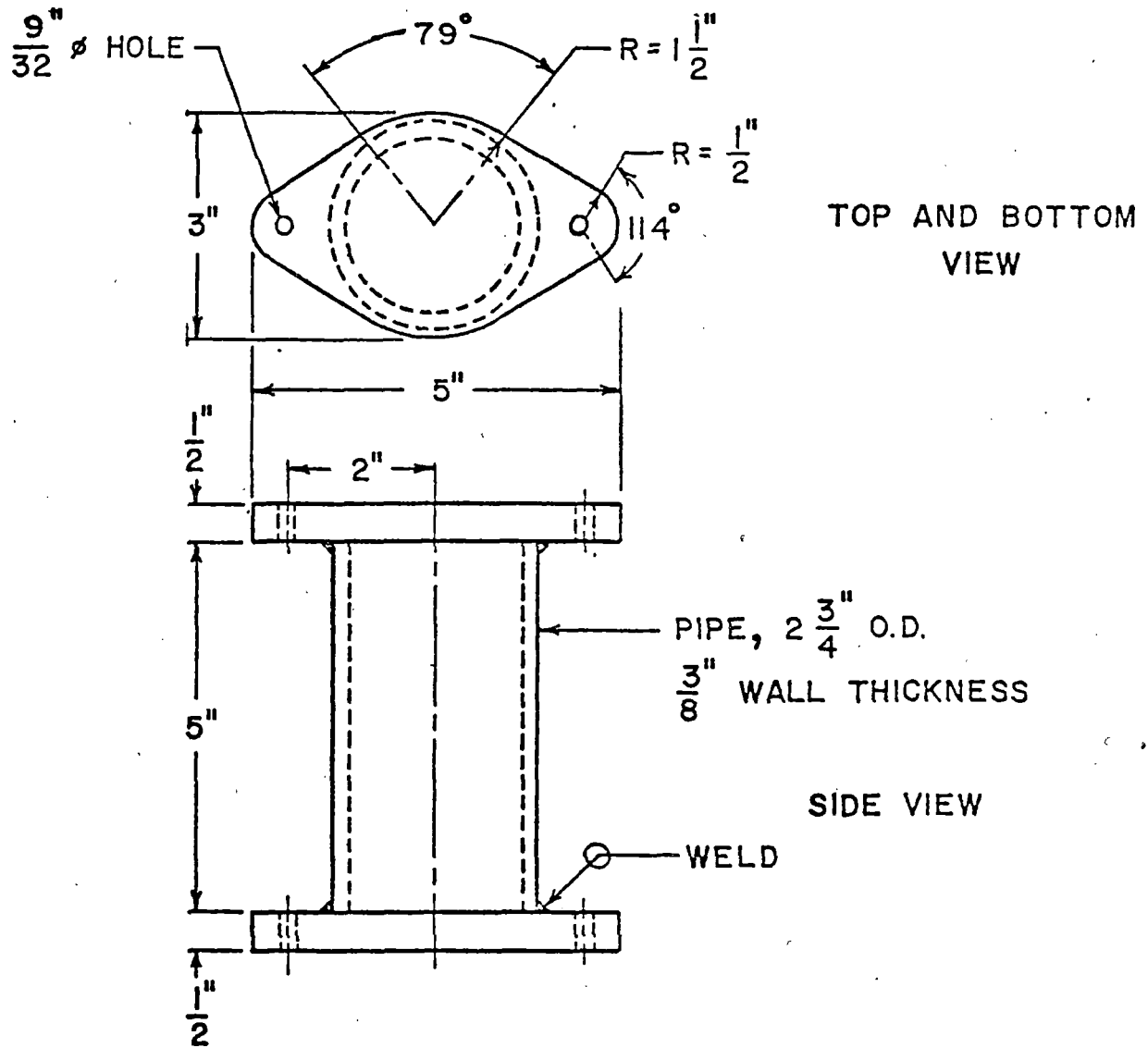

FIGURE C-6. SPACER CYLINDER



C-7

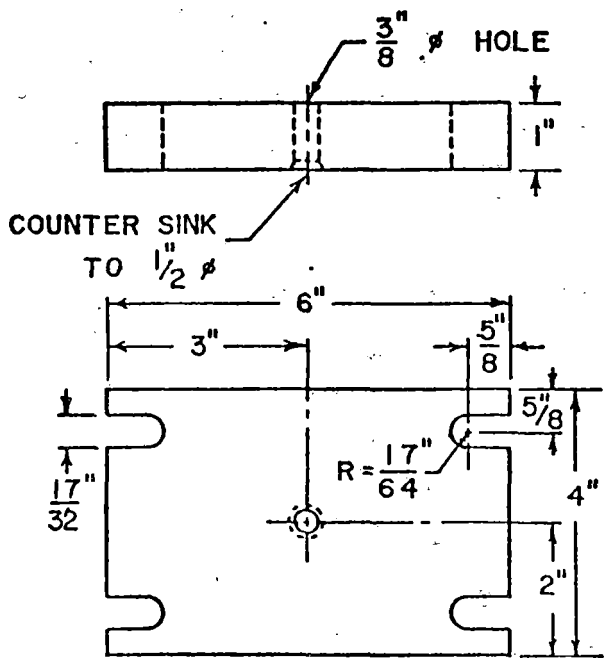

FIGURE C-7. THRUST PLATE

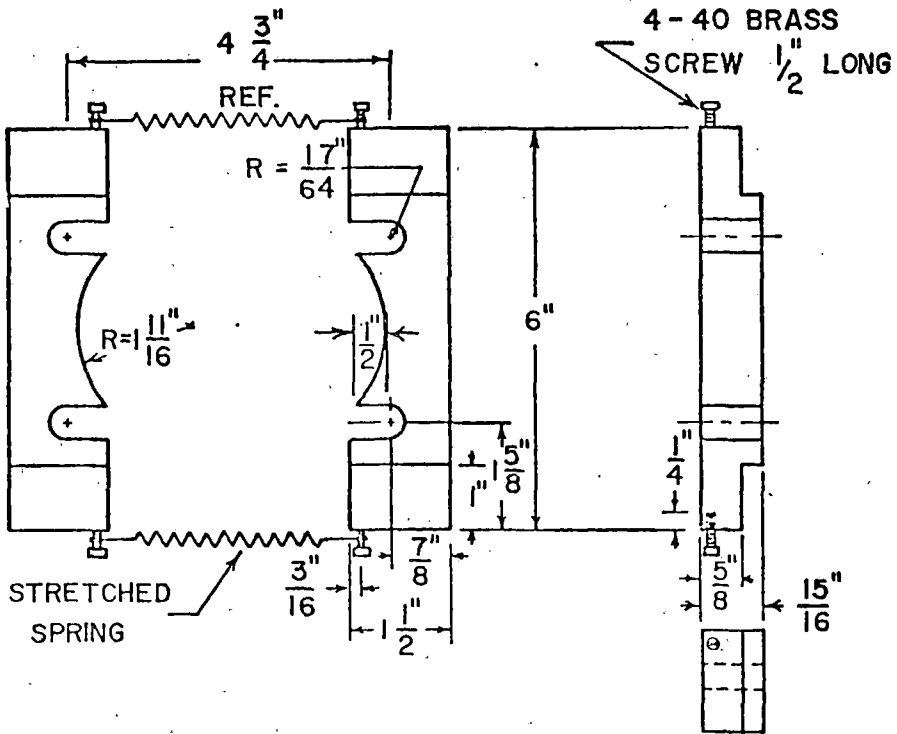

FIGURE C-8. REACTION PLATES

(15.2 cm)-long steel pipe section with a 2-3/4-in. (7.0 cm) diameter and 3/8-in. (0.95 cm) wall thickness. At each end is welded a 1/2-in. (1.7 cm)-thick steel bearing plate having a shape compatible with the connection between the load cell and the moving head of the hydraulic jack. The spacer cylinder is rigidly fastened to both units. The end bearing plates also must be parallel with each other and perpendicular to the load jack piston axis. The length of the pipe section depends upon the stroke of the load jack, the lengths of the load jack and load cell and the needed vertical spacing.

f. Load Jack Support Frame

The load jack support frame (Fig. C-9) serves the dual purpose both of holding the hydraulic load jack and load cell assembly and also of transferring the applied load from the bearing plate to the structural load frame. This support frame must have a structural capacity equivalent to the maximum loads expected for the load jack and load cell.

Four 1/2-in. (1.27 cm)-diameter threaded steel rods in a rectangular array, connect the thrust plate (Fig. C-7) and a jack support plate (Fig. C-10). The rods must have a minimum length of 6 in. (15.2 cm) plus the depth of the structural section of the structural load frame. In this apparatus the rods were 13-1/2 in. (34.3 cm)-long. The thrust plate is secured by 8 nuts at one end of the four rods. Slotted holes in this plate make the frame assembly easier. A 1/4-in. (0.64 cm)-diameter bolt through the center of the thrust plate into the bearing tip supports the weight of the hydraulic jack when the jack is not loaded.

g. Reaction Plates

The reaction plates (Fig. C-8) are held together by a pair of springs to prevent slippage from the rods in the frame. The location of the reaction plates is set so that the distance to the roller bearings on the support plate is equal to the depth of the structural load frame. The reaction plates are completely adjustable in the field once the entire hydraulic load jack assembly is inserted between the structural sections of the structural load frame.

h. Jack Support Plate

The jack support plate (Fig. C-10), located immediately below the thrust plate, performs the following functions: a) for vertical adjustment of the hydraulic load jack assembly to the proper height above the displacement

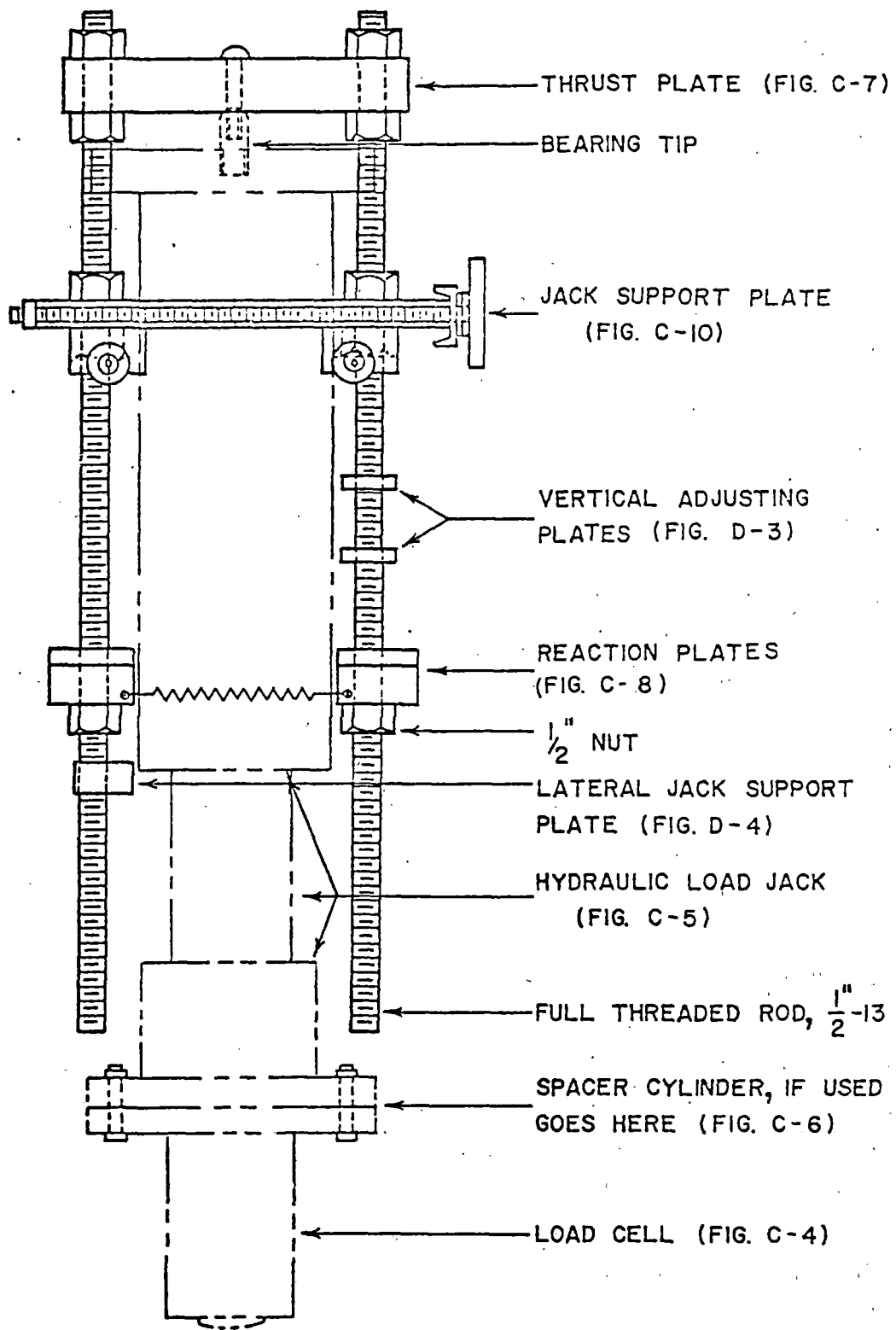

FIGURE C-9. LOAD JACK SUPPORT FRAME

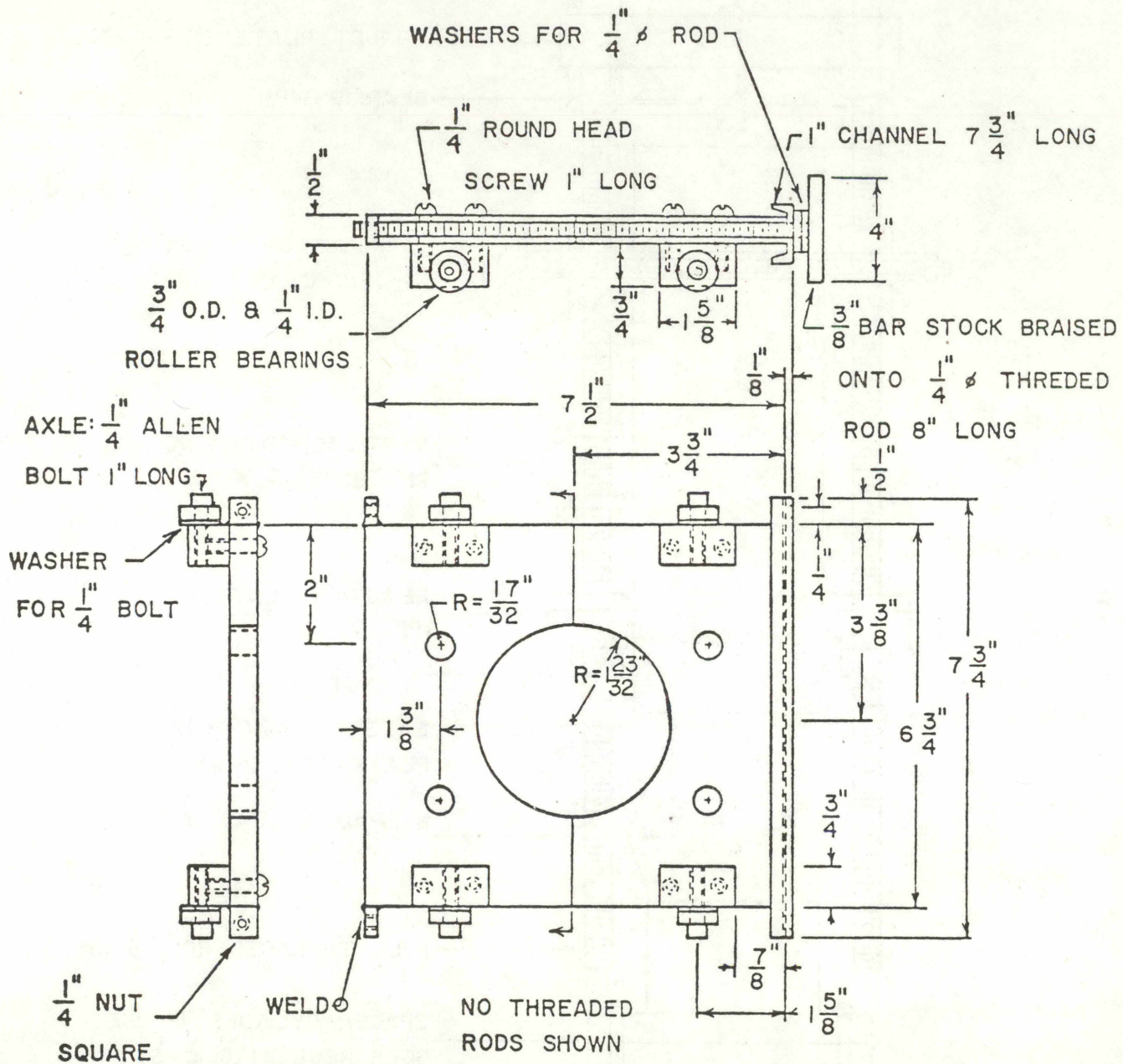

FIGURE C-10. JACK SUPPORT PLATE

reference block, b) as a partial lateral brace for the load jack, c) to make the load instrumentation support and reaction frame a rigid unit, and d) with the four roller bearings, the entire assembly can easily be moved along the length of the structural load frame to allow for proper positioning of the load cell over the displacement reference block (Fig. C-3). The support plate is all steel construction and essentially consists of two halves of a square plate 1/2-in. (1.27 cm) thick connected by two 3/8-in. (0.95 cm)-diameter and 7-in. (17.0 cm) long bolts. When the two halves are joined, the plate has a hole in the center 1/16 in. (0.16 cm) larger than the outside diameter of the load jack and four holes set to the proper spacing for the threaded rods of the load support frame. Also mounted at the edges and near the corners of the plate are four 3/4-in. (1.9 cm)-diameter roller bearings, with a track width equal to the center-to-center distance between the two structural members of the structural load frame.

#### i. Structural Load Frame

The structural load frame provides the mechanism through which a sufficient dead weight will produce the desired reaction for the plate load applied to the ballast surface. The dead weight reaction is supplied by the weight of the track structure in the vicinity of the test zone. However, in addition, a track vehicle should be located as close as possible to the test location to provide additional dead weight reaction to the track. High upward forces applied to the track by the PLT apparatus might otherwise cause track buckling. The frame must have sufficient capacity to resist the expected applied maximum loads.

The two basic components which comprise the frame are steel structural sections (Fig. C-11) and rail clamps (Fig. C-12).

The two structural sections should have a length of 8 ft (244 cm) and be spaced apart at a distance of 3/4 to 1 in. (1.91 to 2.54 cm) greater than the distance to the outsides of two threaded rods in the jack support frame. This latter feature allows for proper positioning of the load cell over the displacement reference block in the direction parallel to the rails.

Two rail clamps are attached to the structural sections by 1/2-in. (1.27 cm)-diameter threaded steel rods passing through the rail clamp pressure plates. The separation of the rail clamps is equal to the distance between the centerlines of the two rails. The threaded rods are fastened to the structural sections. The length of the pressure plate is equal to the

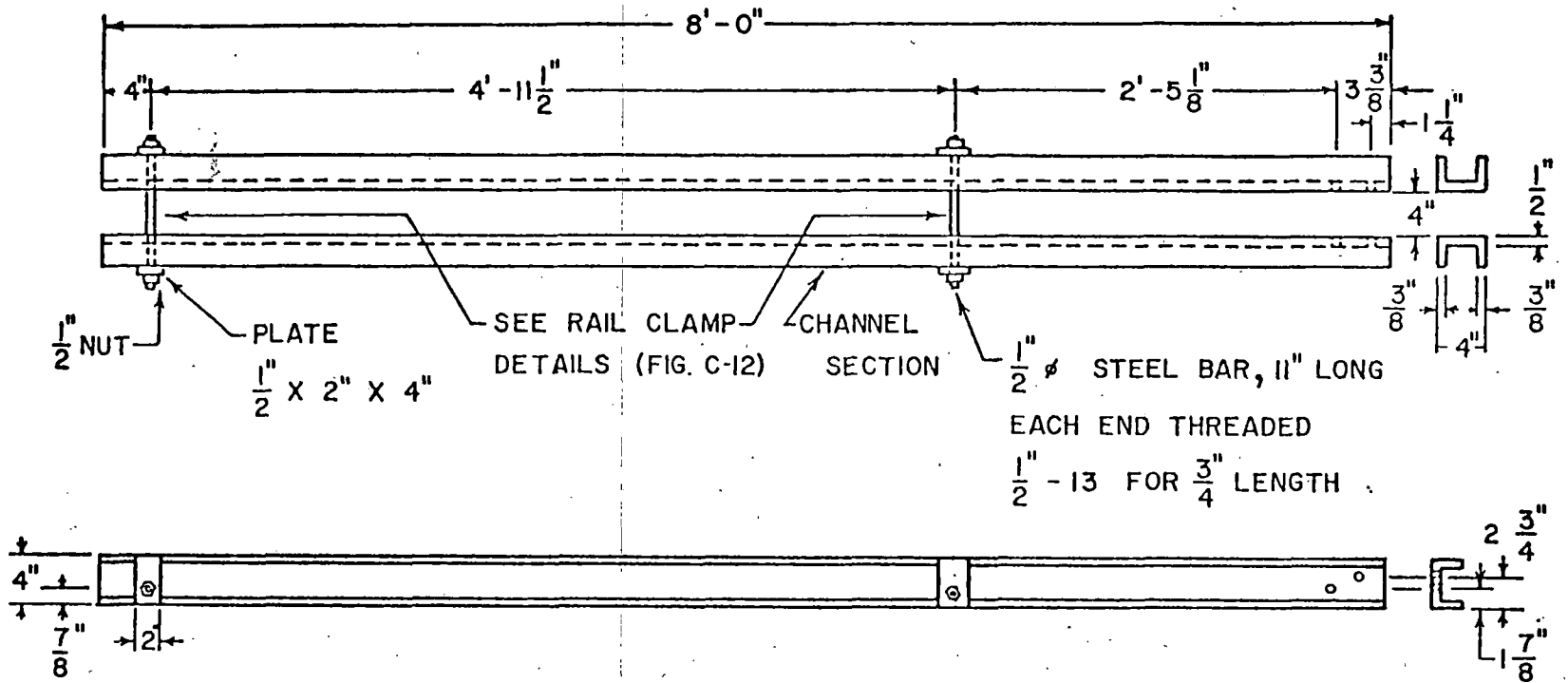
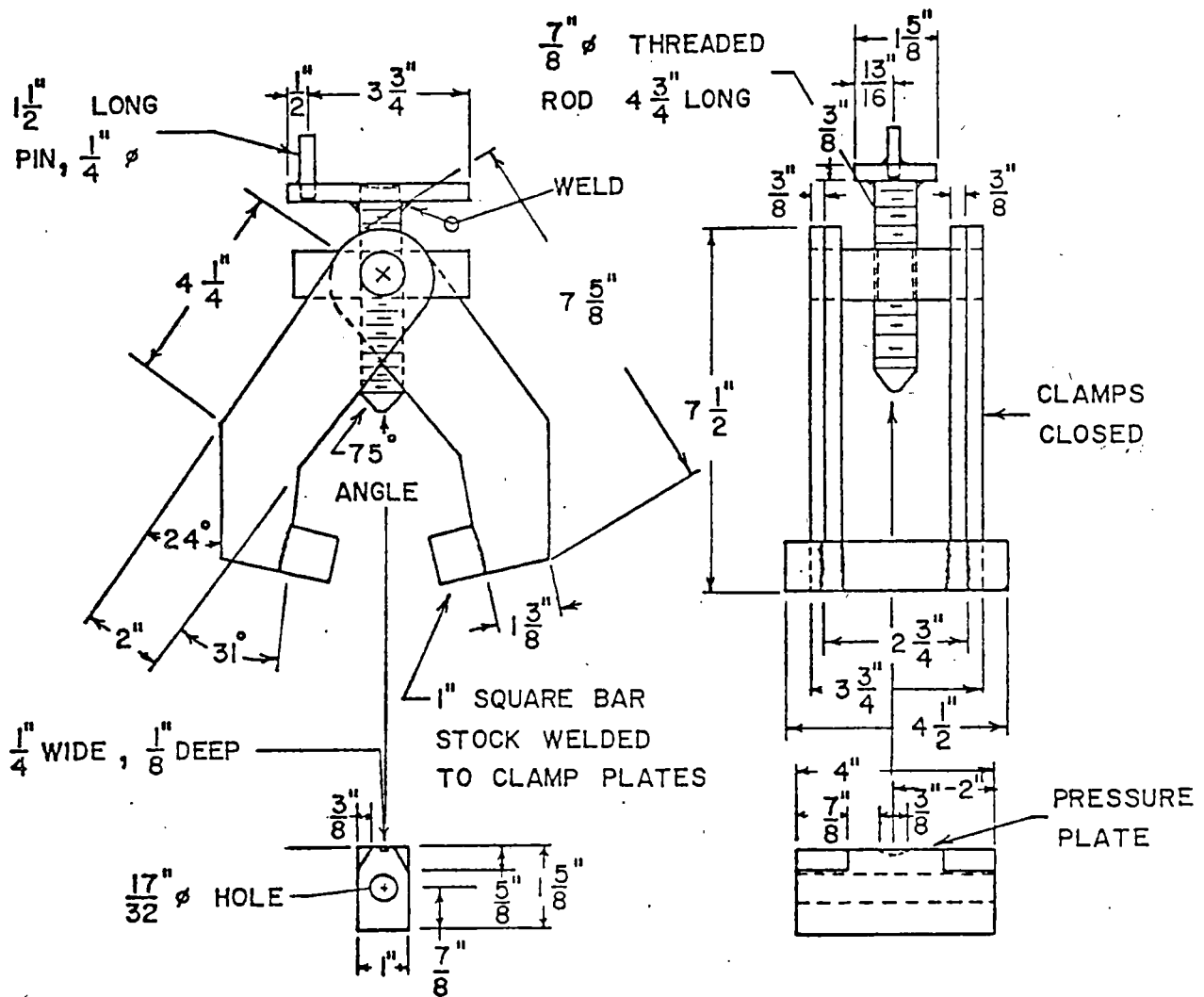
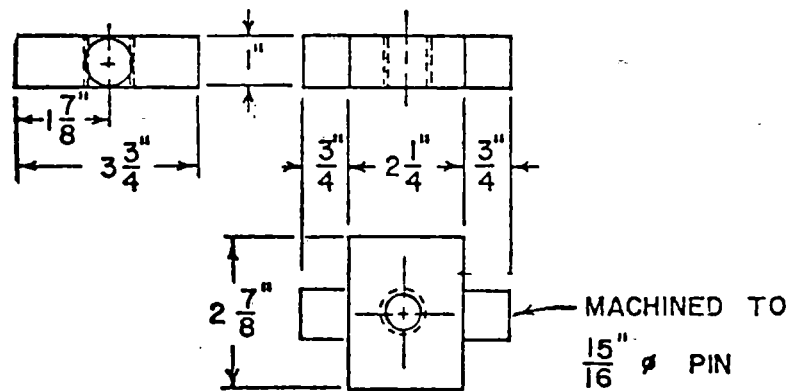

FIGURE C-11. STRUCTURAL LOAD FRAME SECTIONS



a) Clamp



b) Thrust Plate

FIGURE C-12. RAIL CLAMPS



distance between the structural sections, while the rail clamps are 1/8-in. (0.32 cm) smaller in total width. A rail clamp is forced against the underside of the rail heads by tightening the pivotal adjusting screw. This will restrict vertical and horizontal movements of the frame relative to the rails. The frame is designed for standard track gage and can be used on standard rails. Difficulty will arise in using these rail clamps at joints in bolted track.

## 2. Deformation System

The deformation support system ensures proper support and alignment of the displacement instrumentation with the deformation reference pivot in the displacement reference block. The following are the components of the deformation support system.

### a. Deformation Reference Beam

The deformation reference beam and support pivot arm are the key elements of this system (Fig. C-13). The 7-5/8-in. (19.4 cm)-long, 3/8-in. (0.95 cm)-deep and 1/4-in. (0.64 cm)-wide aluminum reference beam is notched at one end. This notch is inserted the full distance of the slot underneath the deformation reference pivot in the displacement reference block. Thus, the center point of the reference pivot is located 1/4-in. (0.64 cm) from this end of the beam. Fastened at the other end of the reference beam is an aluminum reference plate with a recessed seating hole to accommodate the piston of the displacement gage. In the center of the beam is a 1/8-in. (0.32 cm) diameter pivot pin, which is press fit into a notched magnesium (option aluminum) pivot arm. The beam rotates freely about the pivot pin, but is restricted from movement in any other direction. The exact distance from the center of the pivot pin to the center of the seating hole is 3-1/2-in. (8.89 cm) and equal to the distance from the center of the pivot pin to the center of the deformation reference pivot in the reference displacement block. Thus, a direct measurement of displacement is obtained. The length of the reference beam was determined to be the minimum acceptable length such that the deformation system would not interfere with the load system. The notch in this beam always maintains contact with the reference pivot since added weight is applied at the other end by the seating plate and force from the spring in the displacement gage. Measured displacement readings are acceptable if the load bearing plate does not rotate more than 5 deg during testing.

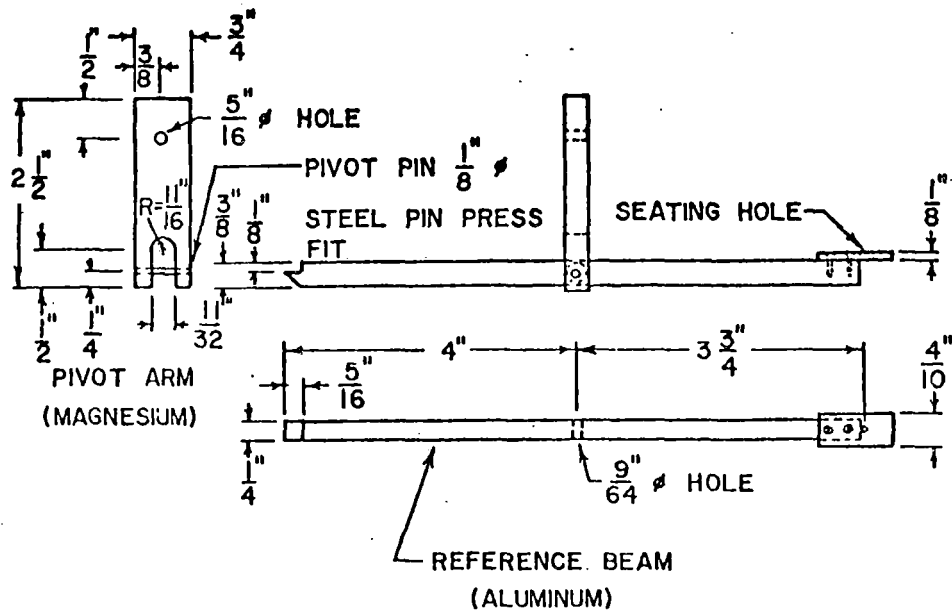

FIGURE C-13. DEFORMATION REFERENCE BEAM

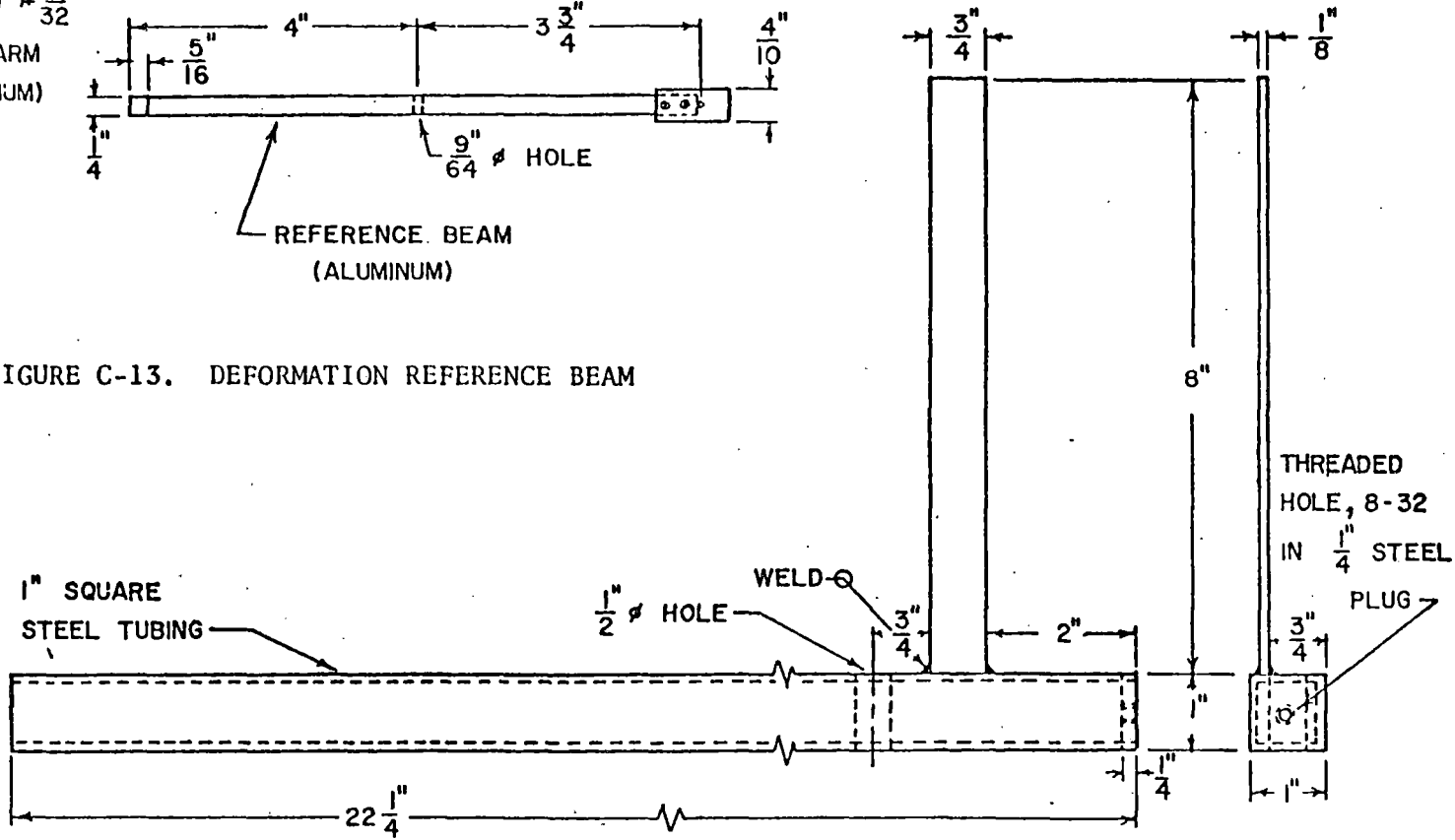

FIGURE C-14. DEFORMATION SUPPORT BEAM

#### b. Deformation Support Beam

The deformation support beam (Fig. C-14) both supports and correctly aligns the displacement gages with the deformation reference beam. The pivot arm must be perpendicular to the support beam. The support beam consists of 1-in. (2.54 cm) square steel telescopic tubing 22-1/4-in. (56.5 cm) long with a 1/4-in. (0.64 cm) steel plug at one end, which has a threaded hole for the support pivot arm bolt. On the top of the tube section at 3-1/2-in. (8.89 cm) from the plugged end is a 1/2-in. (1.27 cm)-diameter hole for the displacement gage piston to pass through. A steel slide plate, which is 1/8-in. (0.32 cm) thick by 3/4-in. (1.91 cm) wide and 8-in. (20.3 cm) long, is welded 1/16-in. (0.16 cm) from the edge and perpendicular to the top of the tubing. The plate is mounted 2-in. (5.1 cm) from the plugged end and is used to adjust the displacement gages on the support track for the proper vertical height.

#### c) Support Beam Slide and Level

The support beam slide and level (Fig. C-15a) is fastened to the bottom of a camera tripod by a single bolt and is used for lateral adjustment of the deformation support beam with respect to the displacement reference block. The slide is a steel tube 1-in. (2.54 cm) square on the inside. This permits free movement of the support beam, which has the same dimensions. Once the support beam is in position, a thumb screw lock secures the beam to the beam slide. A 2-in. (5.1 cm) by 3-in. (7.6 cm) steel plate is welded to the top of the beam slide to hold bubble level in order to insure that the deformation system is level. The distance from the camera tripod connecting bolt to the load area of the plate is roughly 8 to 10-in. (20.3 to 25.4 cm). The lateral or vertical movements of the ballast particles at this distance during loading of the bearing plate are not expected to be significant.

#### d. Support Beam Counter Weight

The support beam counter weight (Fig. C-15b) is used to keep the center of gravity of the deformation system near the camera tripod connecting bolt. A piece of solid steel bar stock is welded to a 3-in. (7.6 cm)-long piece of steel tube the same as the bar slide. This 2.6 lb (1.18 kg) weight slides on the support beam on the opposite side of the support pivot arm and displacement gage. Once equilibrium is reached, the weight is secured in place by a thumb screw.

#### e. Camera Tripod

A camera tripod used to support the entire deformation system is equipped

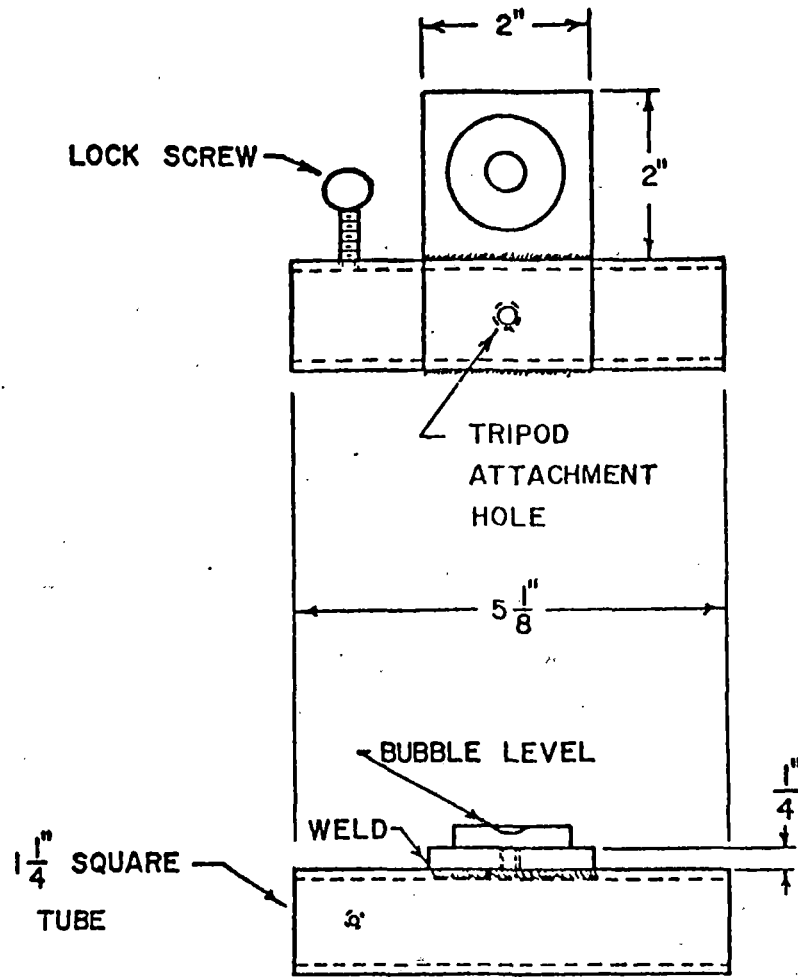

a) SLIDE AND LEVEL

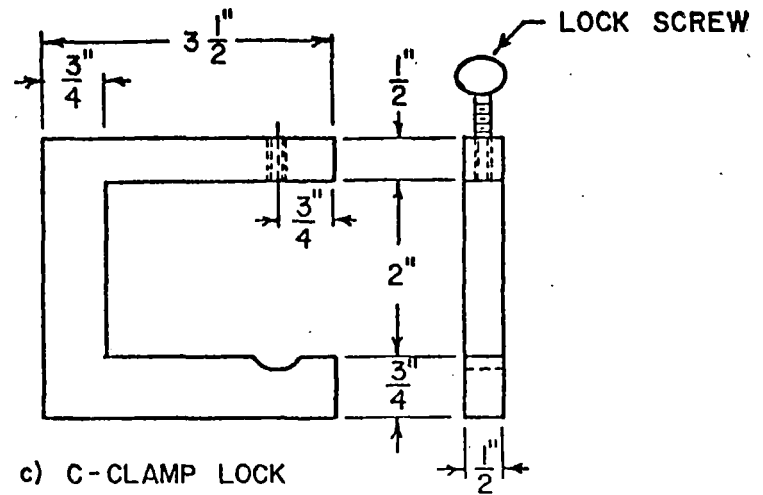

c) C-CLAMP LOCK

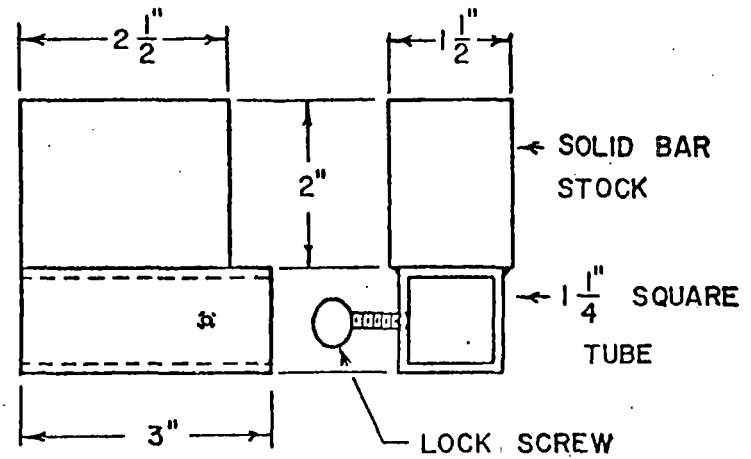

b) COUNTERWEIGHT

FIGURE C-15. SUPPORT BEAM COMPONENTS

with adjustments for aligning and leveling the system. The tripod stands approximately 8-in. (20.3 cm) high when the three legs are fully opened. In the center of the tripod is a notched rod 8-in. (20.3 cm) long, which is connected to the support beam slide. A small hand crank moves the rod vertically. The camera tripod must be of the type that the camera mount pivot may be remounted at the bottom of the vertical adjustment rod for attachment to the support beam slide. When the proper height is reached, i.e., when reference beam is at the same elevation as the bottom of the reference pivot, the rod can be secured by a lock screw. At the bottom of the rod and fastened directly to the beam slide is a ball bearing connected to another lock screw. This feature allows for small rotations of the deformation system in the plane nearly perpendicular to the vertical adjusting rod such that the system can be leveled. The vertical and rotational adjustments should be performed together in order to position the reference beam nearly level, but preferably 0.15 in. (0.38 cm) downward from horizontal at the seating plate. This condition is desirable since it will optimize the rotation of the reference arm by allowing the minimum horizontal displacement at either end of the reference beam due to rotation.

f. Support Beam C-Clamp Lock

The support beam c-clamp lock (Fig. C-15c) clamps the deformation support beam to one leg of the camera tripod. This provides for a more stable and rigid deformation system and prevents possible rotations due to fasteners or connections not tightened securely.

g. Displacement Transducers

An electronic displacement transducer provides a continuous displacement response of the plate during loading and unloading. The transducer must have sufficient travel (preferably 1-in. (2.54 cm)). Input voltage to the transducer is supplied by an appropriate power source and the output signals are recorded by a compatible X-Y recorder. The proper attachments should be fabricated to suitably connect and align the displacement transducer with the dial indicator piston.

A dial indicator is used to provide a means of calibrating the electronic transducer and also provide a visual check on the displacement during the plate loading. The indicator is graduated in units of 0.001 in. (0.00254 cm) and is capable of recording a maximum deflection of 1-in. (2.54 cm). The mechanical spring loaded piston should move freely and be

suitably connected to the electronic displacement transducer. The piston should also have attached a brass displacement calibration lever (Fig. C-16), which has a lever length of 3/4-in. (1.91 cm).

#### h. Displacement Gage Support Track

The displacement gage support track rigidly attaches and aligns the displacement gages such that their pistons freely move (Fig. C-16). The dial indicator is bolted and the displacement transducer is securely fitted with a retainer clamp conforming to the shape of the transducer. The track is a 1-in. (2.54 cm) magnesium angle section with one leg notched 1/8-in. (0.32 cm)-wide and 1/2-in. (1.27 cm)-deep for the full length of the section. The length should be sufficient to accommodate the sizes of displacement gages used. The dial indicator should be positioned on the gage support track such that reading can easily be recorded. The deformation system is placed between the structural sections of the structural load frame, which may interfere with obtaining the readings. The notched leg fits tightly to the slide plate of the deformation support beam and the track can be vertically positioned to align and set the gage piston within the seating hole in the reference beam. Lock screws secure the track to the slide plate once positioning is completed.

### 3. Other Equipment

The following other essential material and equipment is needed:

- a. Plaster of paris and appropriate mixing pans and tools.
- b. Bubble level to adjust plate orientation.
- c. X-Y recorder for load and displacement.
- d. Suitable power supply for instrumentation.
- e. Track car to carry apparatus and instrumentation box.

### C.2 Field Test Procedures

The following steps are involved to measure the in-situ ballast plate load resistance using apparatus described in section C.1:

1. For tests on the tie bearing area, carefully remove all the ballast in both adjacent cribs for the full depth and length of the tie. Carefully remove the spikes, tie plates and rail anchors such that minimal disturbance to the tie occurs. Rail jacks may be placed in the next adjacent full crib

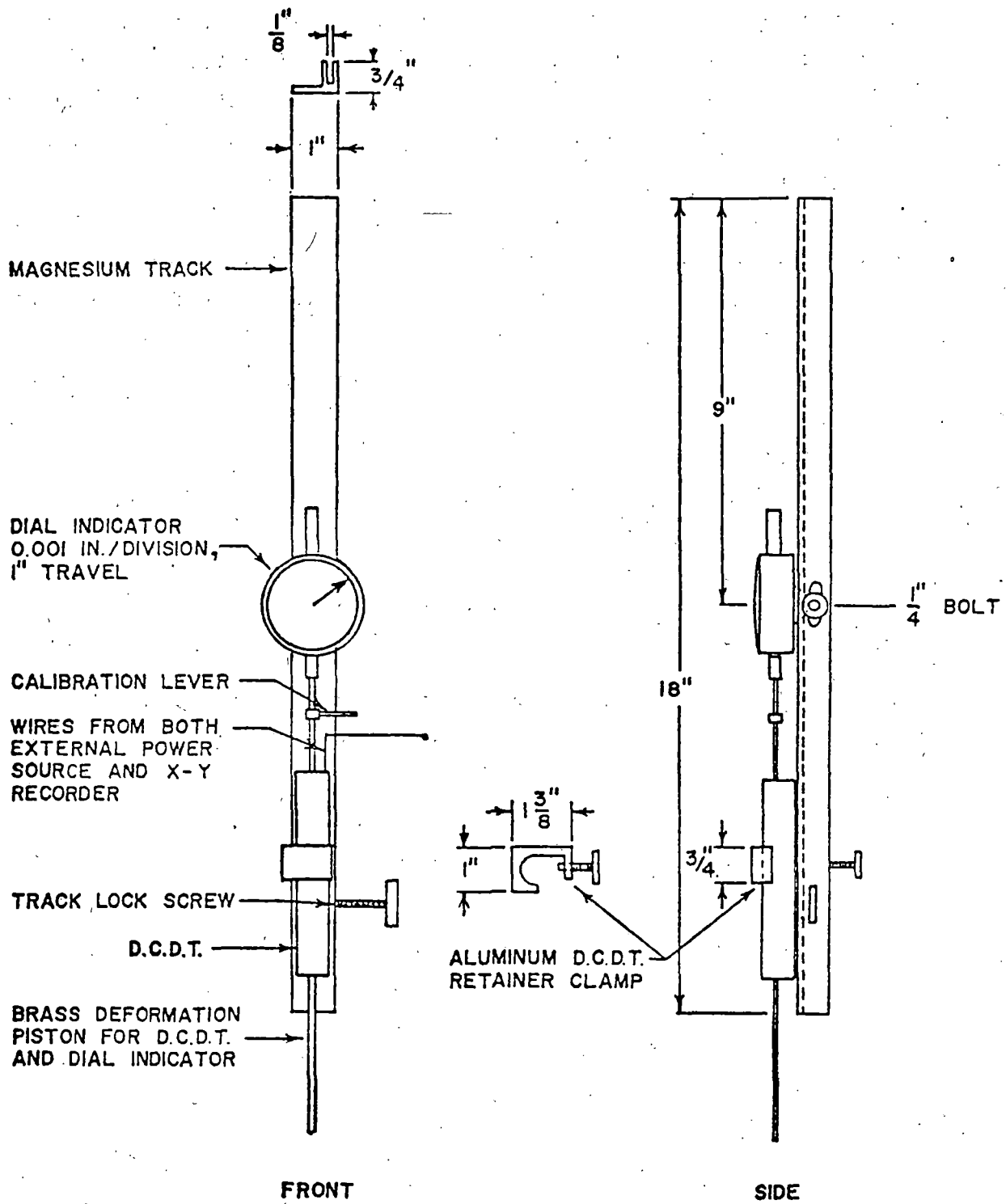

FIGURE C-16. DISPLACEMENT INSTRUMENTATION MOUNTED ON DISPLACEMENT GAGE SUPPORT TRACK

not to be tested to raise the rail. Carefully remove the test tie with tongs such that minimal disturbance occurs to the ballast bed under the tie and to the crib selected for testing. No removal of track components is necessary for tests in the crib providing that the deformation system is positioned in the crib. If the deformation system is position on an adjacent tie, then the rail spikes must be removed from both ties adjacent to the crib designated for testing.

2. Select the center of spots to be tested in the crib and under the tie. These might be the center of the track and 5 to 8-in. from the rail base on the inside and outside of the rail. Mark the location on a drawing. Identify each test plate with a number from the data sheet.

3. In the crib remove any high ballast particles in the plate seating area in order to achieve as level a surface as possible. Under the tie, removal of particles is not necessary.

4. Mix one pound of plaster of paris with two pounds of water and spread thinly over the plate seating area.

5. Place the 5-in.-diameter load bearing plate on the plaster of paris and level the plate with a bubble level. Trim and remove the excess plaster of paris from around the circumference of the plate. Wait 15 to 20 minutes for the plaster to set. The resulting thickness of the plaster of paris between plate and ballast particles should be approximately 1/8-in.

6. Place PLT structural load frame on the rails in a position straddling the plate.

7. Record the position coordinates of the test plate with reference to the rails and adjacent ties. All measurements should be made within 1/8-in. (0.32 cm). The load frame may be used as a reference datum for elevation measurements.

8. Insert the hydraulic load jack assembly in the PLT frame over the test plate. In the case of PLT tests under the tie, a 7-in. spacer disc is first inserted between the load jack and load cell.

9. Place the displacement reference block on the load bearing plate.

10. Use the hand pump to move the load cell such that contact is nearly made with the concave seat in the displacement reference block.

11. Adjust the structural load frame and the hydraulic load jack frame so the loading piston is above the center of the reference block. Tighten the nuts for the reaction plates; also, the rail clamps on the structural load frame.



12. Set up the camera tripod with the deformation system on level ballast or on a tie plate placed on the ballast to give a firm foundation.

13. The displacement instrumentation mounted on the gage support track can then be aligned and attached to the slide plate on the deformation support beam. Temporarily seat the piston in the hole on the reference plate. Level the deformation system by using the adjusting lock screws on the camera tripod. Adjust the deformation system until the reference beam can be inserted properly in the slot and under the deformation reference pivot in the displacement reference block. The displacement gages should be positioned such that there is approximately 3/4-in. (1.91 cm) of travel available.

14. Attach the related cables for the load and deformation systems to the appropriate input lines on the recorder and to the appropriate external power sources.

15. Inscribe X and Y reference axes on the graph paper, when it is properly positioned and attached to the recorder. Record the date, air temperature and test number on the graph paper and on the data sheet.

16. Record several calibration traces for each load and displacement on the X-Y plotter. For displacement calibration, first set the dial indicator on a zero reading. Use the displacement calibration lever on the dial indicator piston and move the lever upward to the full displacement calibration distance. A value of 0.2-in. (0.51 cm) is suggested. Record the calibration displacement value on the graph paper. Load calibration can best be done electrically.

17. The recorder pen may now be conveniently positioned on the graph paper to record the load-displacement curve. Mark the origin point on the graph paper.

18. Use the hydraulic hand pump to move the load jack and also the load cell until the loading piston is nearly in contact with the seating hole in the displacement reference block.

19. Record initial hydraulic jack system pressure, initial deformation dial reading, and the cycle number.

20. With the hydraulic hand pump, displace the piston at a constant deformation rate of about 0.25 in./min. until 0.3-in. of displacement is reached. At this point, simultaneously record peak hydraulic jack pressure, and displacement reading from the dial indicator.

21. At the instant peak displacement is reached, unload the plate at approximately the same rate as in loading. When the plate is completely unloaded, but with the loading piston nearly in contact with the plate, record the dial indicator reading.

22. Perform additional cycles of plate loading to the same peak pressure as in the 1st cycle. Use the same test procedure and record the same load and deformation values. The rebound displacement point of the previous cycle on the graph paper may be used as the origin point for the next loading cycle plot.

23. Record any unusual test condition such as excessive plate rotation, particle degradation, amount of fine ballast material, degree of saturation of the ballast, or problems encountered during testing.

24. Use the load and displacement calibration signals to properly scale the axes of the recorded load-displacement curve. Then compute all desired strength indices for the first cycle of loading only, such as: Ballast Bearing Index (BBI), Modified Ballast Bearing Index (BBI<sub>k</sub>), Modified Resilient Modulus (E<sub>rm</sub>), Modified Modulus of Deformation (E<sub>m</sub>), and the percent Elastic Recovery (E<sub>r</sub>) as

$$E_r = \left( \frac{\Delta_L}{\Delta_C} \right) 100 \quad , \quad (C-1)$$

where  $\Delta_L$  and  $\Delta_C$  are recoverable and total deformation, respectively, per cycle (in.). For each additional cycle, compute only E<sub>rm</sub>, E<sub>m</sub> and E<sub>r</sub>.

APPENDIX D. APPARATUS AND RECOMMENDED PROCEDURES  
FOR FIELD LATERAL TIE PUSH TEST (Ref. 1)

D.1 Apparatus

The assembled apparatus for the lateral tie push test is shown in Fig. D-1. Each component will be described in detail and its function will be explained in this appendix. The presentation is subdivided into two categories: 1) the load system, and 2) the deformation system.

1. Load System

a. Serrated Seating Plate Assembly

The serrated seating plate assembly (Fig. D-2) insures good seating, uniform load distribution and prevention of load cell slippage during testing at the tie end. The assembly fits over the load cell and is fastened to the load cell attachments on the moving head of the hydraulic load jack. The plate also serves as a vertical adjusting guide for centering the hydraulic load jack assembly at the tie end.

The key component is a 1/2-in. (1.27 cm)-thick aluminum serrated seating plate 5 in. (12.7 cm) square. The plate area covers a sufficient portion of the end area of most standard ties. The non-serrated side of the plate has a centered seating hole of the same shape as that of the PLT displacement reference block to fit the load bearing piston of the load cell.

The serrated plate is connected at the edges by four springs, which are fastened to 1-1/2-in. (3.21 cm)-long eyebolts in a 1/4-in. (0.635 cm)-thick aluminum annulus 6 in. (15.24 cm) in diameter. The annulus has an internal radius to fit the load cell radius and the mating connector. The springs should have a low stiffness and the length is a function of the load cell height. This length is flexible since the eyebolts are used for adjustment to provide a 10-lb (4.54 Kg) force necessary to maintain contact between the serrated plate and the load cell bearing piston.

b. Load Cell

The load cell is the same as described for the PLT in Appendix C.

c. Hydraulic Load Jack Assembly

The hydraulic load jack assembly is the same as described for the PLT in

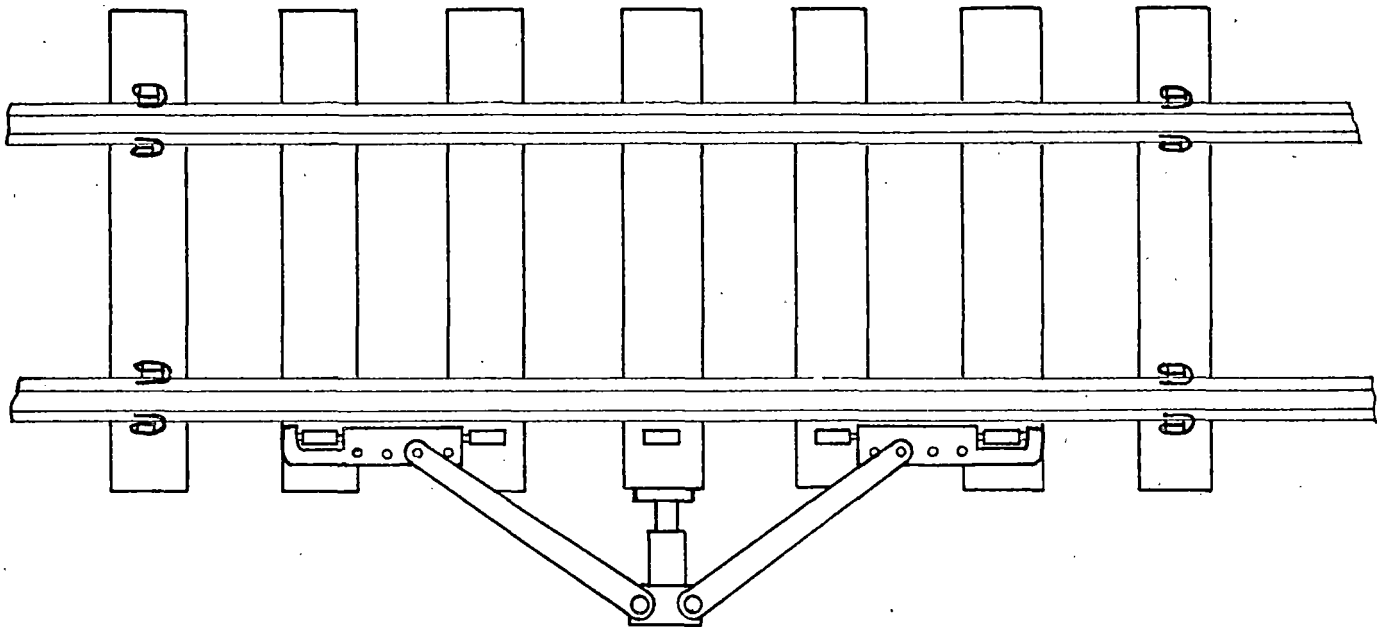

FIGURE D-2. SCHEMATIC ILLUSTRATION OF LATERAL TIE PUSH TEST APPARATUS

Appendix C. However, the lateral jack support plate and the vertical adjusting plates in Fig. C-6 are described below rather than in Appendix C because they are used just for the LTPT.

The lateral jack support plate (Fig. D-4) ensures that the hydraulic load jack assembly maintains a horizontal position parallel with the structural load frame. This plate is necessary, since the load instrumentation is fully supported at one end by thrust and pressure plates and partially supported by the reaction plates near the midpoint of the load jack. The lateral jack support plate is placed on the two bottom threaded rods of the hydraulic load jack assembly and positioned under the outer load jack cylinder nearest to the moving head. This plate consists of a 1-in. (2.54 cm)-wide aluminum bar stock with length and thickness dependent upon the dimensions of the load jack and the load instrumentation support and reaction frame. The top of the plate is inscribed with a seat having a radius equal to the outer load jack cylinder radius. On the opposite face are two seating grooves spaced to fit onto the threaded rods.

The vertical adjusting plates provide the means for raising or lowering the hydraulic load jack assembly so that this unit may be aligned parallel with the tie centerline. These plates are located midway between the pressure and reaction plates and opposite the two threaded rods with the lateral jack support plate. Two 3/8-in. (0.95 cm)-thick steel plates are required (Fig. D-3). The length and width of the plates are again dependent upon the size and spacing of the threaded rods. Allen set screws secure the adjusting plates to the threaded rods at a 1/2-in. (1.27 cm) spacing. The center of each plate has a 1/2-in. (1.27 cm) diameter hole in order to accommodate the connecting bolt for the vertical adjusting screw mounted in the L-frame.

#### d. Structural Load Frame

The structural load frame is the same as described for the PLT in Appendix C, except for the L-frame attachment (Fig. D-5). The L-frame provides support and reaction for the hydraulic load jack assembly, utilizing the track structure as an anchor. The L-frame consists of two 15-in. (38.1 cm)-long structural steel sections similar to those of the structural load frame and spaced at the same distance. The load jack assembly is as mobile in the L-frame as in the structural load frame. Transfer of the assembly is easily accomplished by removing the two steel reaction plates.

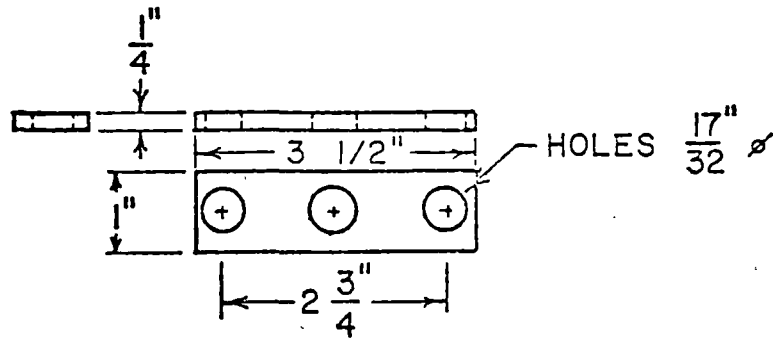

FIGURE D-3. VERTICAL ADJUSTING PLATE

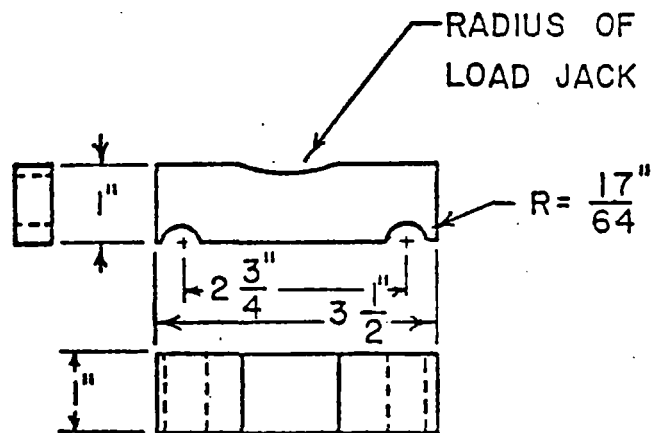

FIGURE D-4. LATERAL JACK SUPPORT PLATE

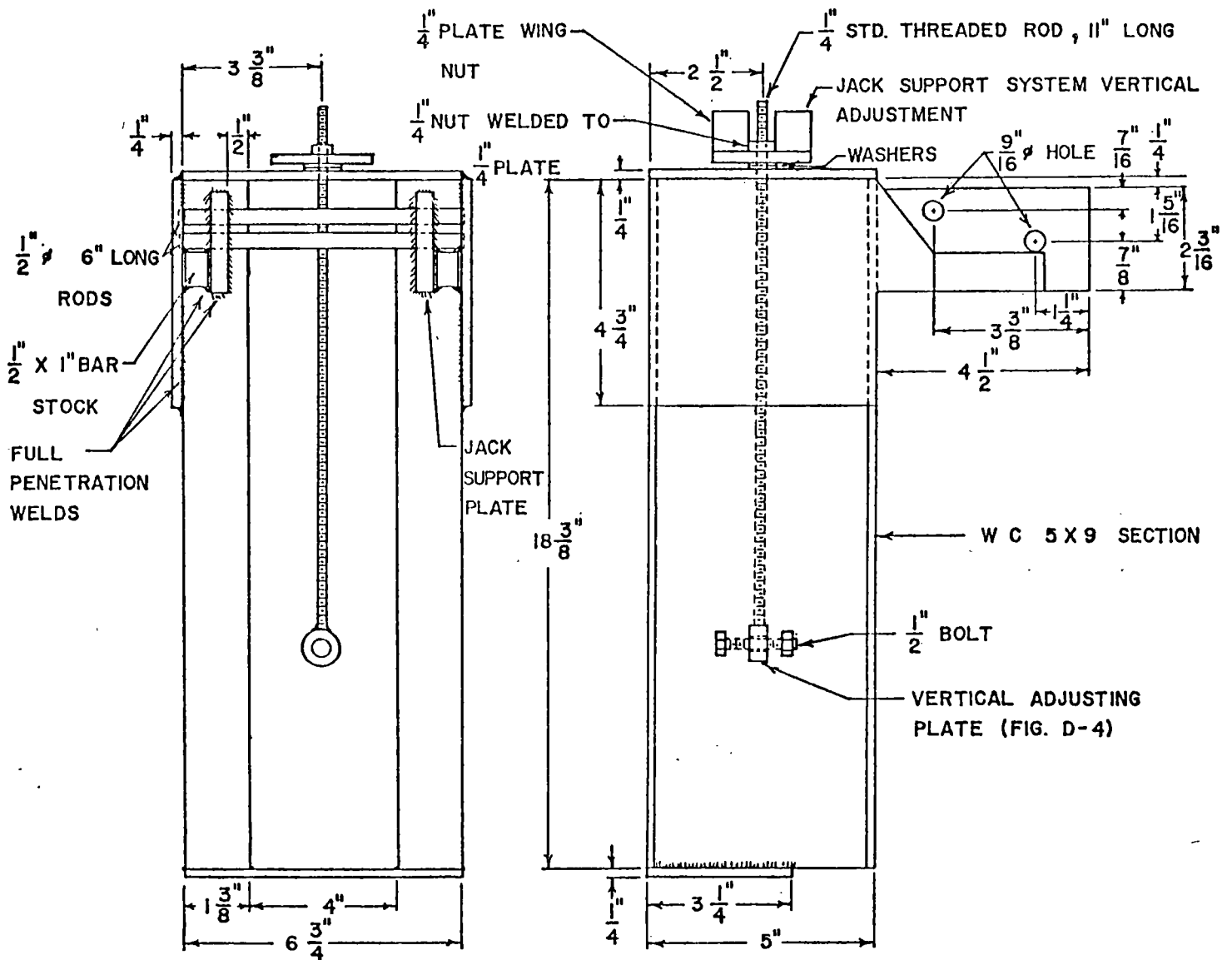

FIGURE D-5. L-FRAME ATTACHMENT TO STRUCTURAL LOAD FRAME

The steel sections are welded at the top and bottom to 1/4-in. (0.635 cm)-thick steel plates. In order to securely fix this attachment with the load frame, steel support plates welded to the top of the structural sections are located and dimensioned so that the L-frame may be snugly inserted between the flanges and perpendicular to one end of the structural load frame. Also, two 1/2-in. (1.27 cm)-diameter steel rods with a length equal to the width of the load frame are inserted through closely fitting holes bored in the same locations in the support plates at the end of the load frame. These rods provide the shear and bending resistance for the anticipated lateral tie loads so that the hydraulic load jack remains parallel to the tie center line under load.

The L-frame should adequately accommodate the hydraulic load jack assembly with adjustments so that the system can easily be adapted to track systems having various rail heights, tie plate thicknesses, and tie depths. The frame is also designed for standard 8-1/2-ft (259 cm)-long ties, but the load jack assembly is flexible enough so that tie lengths from 8 ft to 9 ft (244 cm to 274 cm) can be handled easily.

A 12-in. (30.5 cm)-long and 1/4-in. (0.635)-diameter threaded steel rod with a wingnut adjusting screw is inserted through the top plate of the L-frame and fastened to the vertical adjusting plates of the load jack assembly. This provides a reliable method to vertically adjust the load jack parallel to the centerline of the tie.

## 2. Deformation System

### a. Deformation Support System

The deformation support system is attached to the top of the tie at the end. It supports the displacement gages in order to accurately monitor tie displacement during loading (Fig. D-6). A 37-in. (94 cm)-long, 1-in. (2.54 cm) by 1-in. (2.54 cm) magnesium T-section is bolted to plates holding the horizontal and vertical adjusting screws. The displacement gage support track is capable of sliding into the correct position with respect to the reference stand on any of the legs of this deformation reference arm. This arm has the same thickness as the slide plate in the PLT deformation support system. Therefore, the two deformation systems can be interchanged easily.

Also, the reference arm length just extends beyond the L-frame attachment. This setup provides for the most accurate measurement of displacement



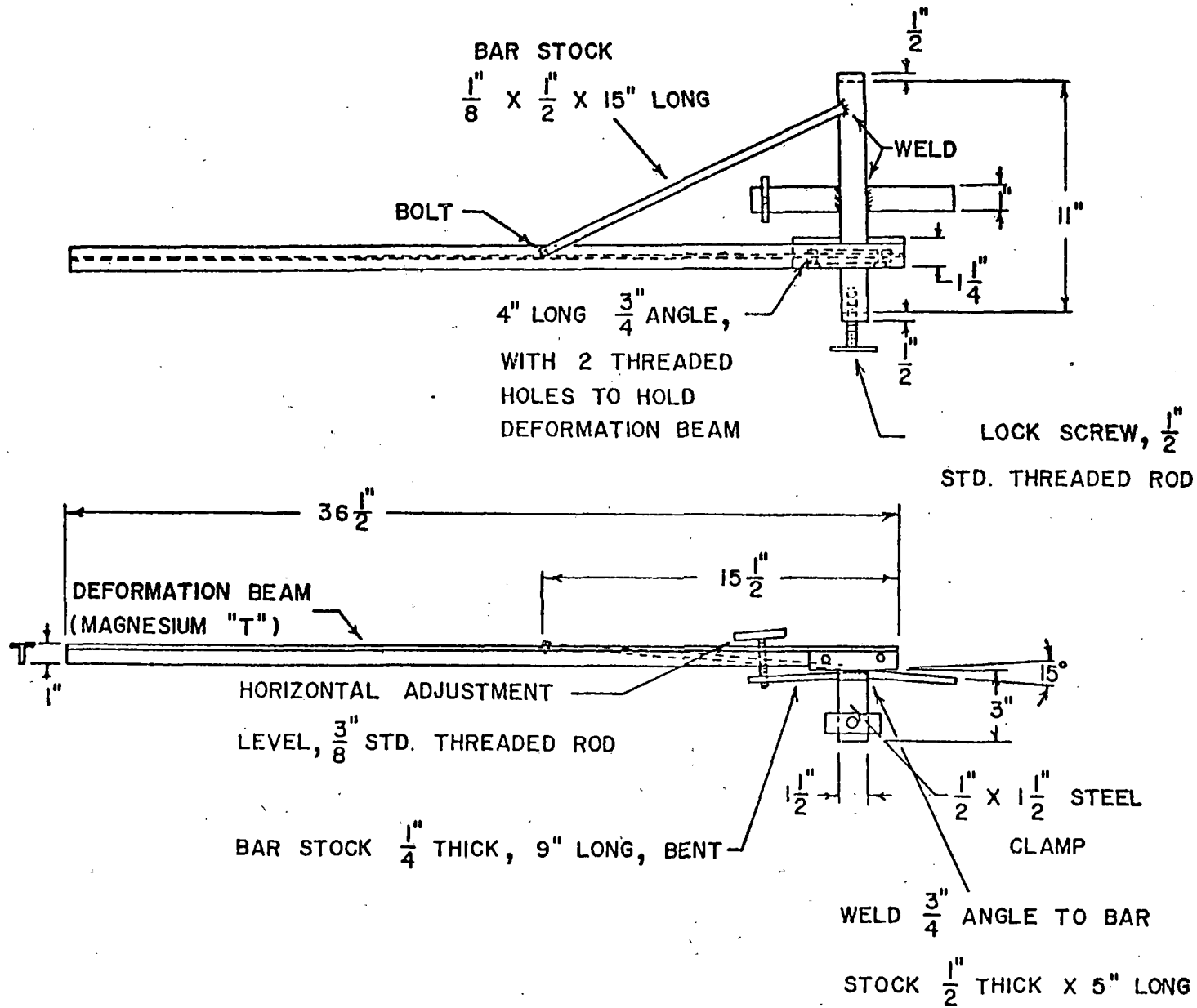

FIGURE D-6. DEFORMATION SUPPORT SYSTEM

readings since 1) the deformation reference stand and displacement gage instrumentation would interfere with the structural load frame at any closer distance; and 2) the tie displacement reference point is far enough away from the loaded tie to be stable.

The deformation reference arm can be visually aligned parallel to the centerline of the tie by the steel vertical and horizontal adjusting screws. The horizontal adjusting screw aligns the reference arm parallel with the side of the tie and is capable of adjusting to different tie widths. The vertical screw aligns the reference arm parallel to the top of the tie, and is used to support the weight of the displacement gage support track and instrumentation at the end of the reference arm.

b. Displacement Transducers

The displacement transducers are the same as described for the PLT in Appendix C.

c. Displacement Gage Support Track

The displacement gage support track is the same as described for the PLT in Appendix C.

d. Displacement Reference Stand

The displacement reference stand (tripod) is firmly seated on the ballast shoulder and away from the test area to provide a reference datum by which the tie horizontal displacement can be recorded accurately. The stand essentially consists of a steel base with three telescopic aluminum legs, adjustable by wingnuts to any angle, and a vertical telescopic tube with an attached 6-in. (15.2 cm)-square steel deformation reference plate 1/4-in. (0.635 cm)-thick (Fig. D-7). The base and reference plate have telescopic structural tubing the same as the PLT deformation guide support and reference beam, respectively, with lengths of 7-in. (17.8 cm) and 10-in. (25.4 cm). The reference plate is secured at a fixed elevation by a vertical adjusting screw mounted on the steel base. Each telescopic leg is a 1-in. (2.54 cm) channel section 6-1/2-in. (16.5 cm)-long fastened to a semi-slotted 5-in. (12.7 cm)-long by 1/4-in. (0.635 cm)-thick aluminum bar stock. The stand can be adjusted for heights of 15 to 22-in. (38.1 to 55.9 cm).

The reference plate is positioned such that the displacement instrumentation mounted on the displacement gage track support is perpendicular to the plate. The reference plate is heavy and stable enough such that mild winds do not affect the displacement reference.

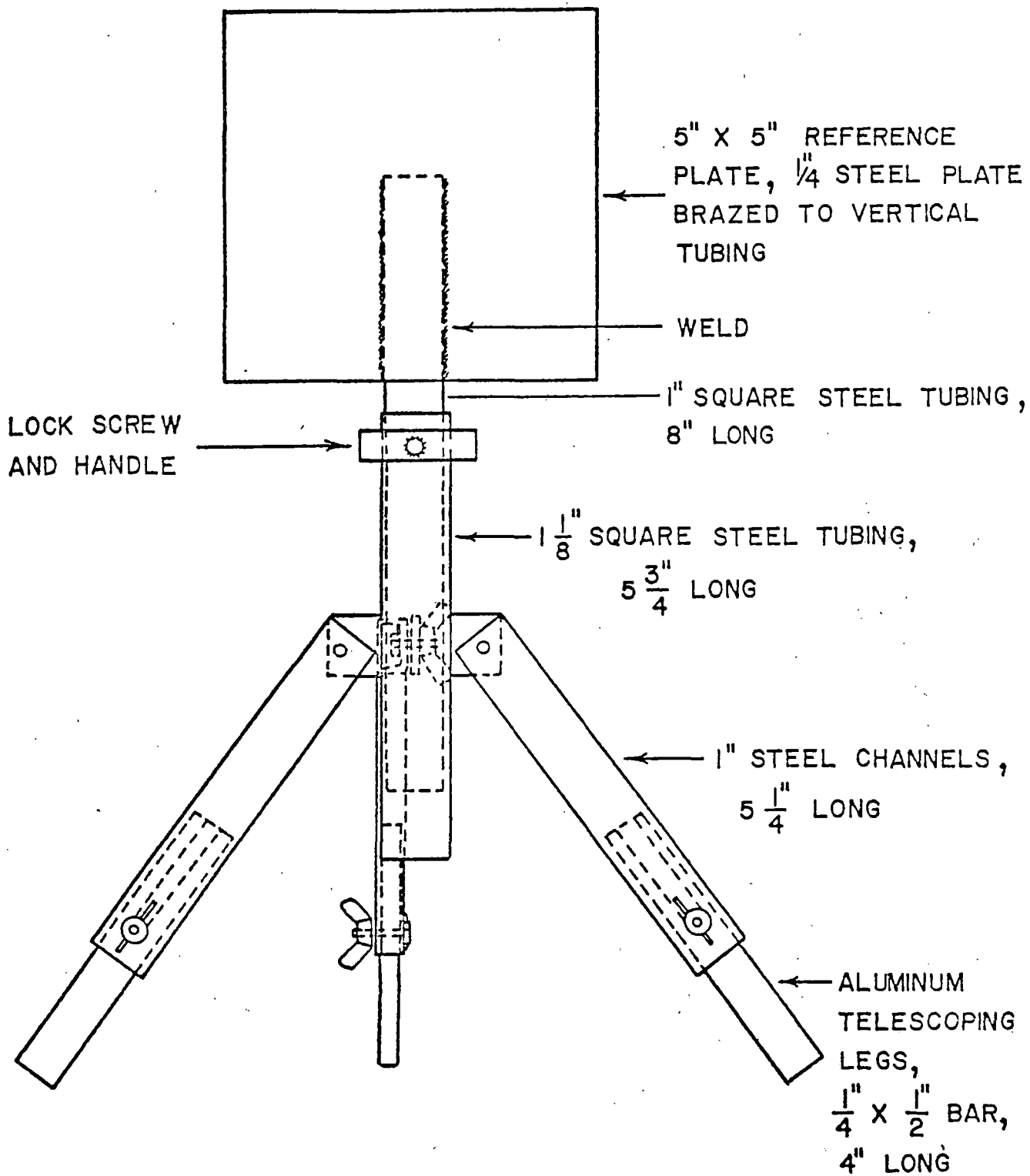

FIGURE D-7. DISPLACEMENT REFERENCE STAND (TRIPOD)

### 3. Other equipment

The following other essential equipment is needed:

- a. X-Y recorder for load and displacement.
- b. Suitable power supply for instrumentation.
- c. Track car to carry apparatus and instrumentation box.

#### D.2 Field Test Procedure

The following steps are followed to measure the lateral tie resistance using the apparatus described in Section D.1:

1. Carefully remove the ballast at the end of the selected tie from the shoulder for the full depth of the tie and the entire width of the shoulder to accommodate the structural load frame with L-frame attachment and the hydraulic load jack assembly.

2. Carefully remove the rail fasteners on five adjacent ties and the pads on the middle selected tie. The use of rail jacks should be avoided.

3. Note and record tie condition and dimensions.

4. Place the structural load frame on the adjacent ties as shown in Figure D-1.

5. Attach the serrated seating plate assembly to the hydraulic load jack assembly and insert the entire unit into the L-frame. Bolt the vertical adjusting screw to the vertical adjusting plates connected to the threaded rods of the hydraulic load jack assembly. Adjust the horizontal position of the load jack assembly to provide for at least 1/2 to 1-in. (1.27 to 2.54 cm) clearance between the serrated plate and the tie end. This is accomplished by adjusting the relative position of the load jack reaction and pressure plates on the load jack assembly. An option to accomplish this would be to insert and fasten a 4-in. (10.2 cm)-long spacer cylinder between the load cell and load jack.

6. Insert the lateral jack support plate on the two bottom threaded rods of the hydraulic load jack assembly and under the load jack.

7. The load frame with the entire hydraulic load jack assembly should be positioned over and parallel to the centerline of the tie. Both rail clamps then should be tightened to secure the frame to the track and

subsequently restrict horizontal and vertical movement of the frame during testing.

8. Use the vertical adjusting screw, mounted on the top of the L-frame, to adjust the vertical position of the hydraulic load jack assembly such that the point of load application is at the center of the tie end and the jack is parallel to the centerline of the tie. The square serrated seating plate may be used as a guide for centering the assembly. At this point the serrated plate should not be in contact with the tie.

9. Remove a small quantity of ballast from the crib near the loaded end of the tie to accommodate the horizontal clamp of the deformation support system. Clamp the support system to the top of the tie end. Adjust the horizontal and vertical clamps to ensure the deformation reference arm is parallel to the centerline of the tie. The reference arm should extend past the end of the structural load frame.

10. The deformation system reference stand (a tripod) is firmly seated on the ballast shoulder. The stand is about three inches (7.6 cm) from the reference arm and also has the reference plate perpendicular to this arm. Use the vertical height adjustment screw to position the reference plate, such that the reference arm is near the center point of the plate.

11. The gage support track which contains the displacement gages, is attached to the reference arm. This track is moved on the reference arm to the reference plate until the dial indicator stem is depressed for approximately 3/4-in. (1.90 cm) travel and is then tightened. The dial stem should be depressed and released to insure free movement of the stem.

12. Attach the related cables for the load and deformation systems to the appropriate input lines on the recorder and to the appropriate external power sources.

13. Inscribe X and Y reference axes on the graph paper, when it is properly positioned and attached to the recorder. Record the date, air temperature and test number on the graph paper and on the data sheet.

14. Record several calibration traces for each load and displacement on the X-Y plotter. For displacement calibration, first set the dial indicator on a zero reading. Use the displacement calibration lever on the dial indicator piston and move the lever upward to the full displacement calibration distance. A value of 0.2-in. (0.51 cm) is suggested. Record the calibration displacement value on the graph paper. Load

calibration can best be done electrically.

15. The recorder pen may now be conveniently positioned on the graph paper to record the load-displacement curve. Mark the origin point on the graph paper.

16. Use the hydraulic hand pump to move the hydraulic load jack assembly until the serrated plate is nearly in contact with the tie end. Record the initial hydraulic jack system pressure and the initial dial indicator readings.

17. The test may commence by displacing the hydraulic load jack piston with the hydraulic hand pump at a constant deformation rate of 0.25-in./min. (0.635 cm/min.) until a maximum deformation of 0.25-in. (0.635 cm) is reached. Simultaneously record the peak hydraulic jack pressure and the peak displacement reading.

18. At the instant peak displacement is reached, unload the tie at approximately the same rate as for loading. When the tie is completely unloaded, i.e., when the serrated plate is not in contact with the tie end, record the tie horizontal rebound displacement reading from the dial indicator.

19. Record any unusual test conditions, i.e., deficient crib ballast and amount, different shoulder width or slope, non-square tie end, skewed ties, degree of saturation of ballast, tie popping, or problems encountered during testing.

20. A second cycle of loading may be performed using steps 16 to 18.

21. The structural load frame and hydraulic jack assembly can be moved to the next test tie and the same test procedure can then be utilized.

22. Use the load and displacement calibration signals to properly scale the axes for each of the recorded load-displacement curve.

23. Compute the load at the following displacement levels for all cycles: 0.0-in. (0.0 cm), 0.039-in. (1 mm), 0.079-in. (2 mm), 0.157-in. (4 mm), and 0.25-in. (6.35 mm).

24. Compute the percent elastic recovery ( $E_r$ ) as

$$E_r = \left( \frac{\Delta_L}{\Delta_C} \right) 100 \quad (D-1)$$

## APPENDIX E. PROCEDURES FOR BALLAST INDEX TEST

1. Oven dry and then sieve the sample on sieves used for coarse aggregate. Use the entire sample if 50 lb or less. If the sample is heavier than 50 lb, then reduce it down to 44 lb (20,000 g) using a sample splitter, and save and label the portion in excess of 44 lb. The maximum sieve size must be 2 1/2 inch and the minimum must be #4. The choice of intermediate sieves should be made to provide approximately equal distribution of the sample among the sieves.

2. Reduce to 500 g by sample splitting or quartering the quantity of material from Step 1 that passes the #4 sieve. Carefully break up lumps with rubber hammer or with rubber rollers in ball mill. Weigh the sample, wash through #200 sieve, and then oven dry and weigh the material remaining on #200 sieve to determine the percent finer than #200. Dry sieve the sample larger than #200 size using the following suggested sieve sizes: 4, 8, 16, 40, 60, 100, 140 and 200.

3. Take the portion of the sample passing the #4 sieve remaining from Step 2 after removing the 500 g sample. Carefully break up lumps as in Step 2 and dry sieve through #40 sieve. Perform liquid limit and plastic limit tests on the material passing the #40 sieve. Save all portions of sample that are required for chemical tests.

4. Perform petrographic analysis to determine the mineral composition of the portion of the sample from Step 3 smaller than the #40 sieve, and the portion larger than the #40 sieve. The method of selection and preparation of the samples for the analysis is quite important and must be specified with the test results. For example, at least the sample larger than #40 should be crushed to pulverize it before conducting the petrographic analysis. Procedures must be employed to ensure that the sample tested is representative of the entire portion.

5. Split the sample > #4 from Step 1 as required to perform the following tests: specific gravity, water absorption, magnesium sulfate soundness, Los Angeles abrasion, petrographic analysis, and descriptive tests such as visual inspection of angularity and sphericity, and hardness. If total sample is not enough to use separate portions for all of these tests, the specific gravity and absorption test portion may be recombined with the remainder of > #4 before conducting the other tests.

6. Determine bulk specific gravity and percent absorption on a portion of sample prepared in Step 5 according to ASTM Procedure C127.

7. Perform the petrographic analysis to determine the mineral composition of the portion of the sample from Step 5 that was larger than #4 size. Pulverize a representative portion of this sample for the analysis and specify the procedures used for preparation and test. Save the unused portion of this sample.

8. Conduct a Los Angeles abrasion test on a portion of material larger than #4 sieve from Step 5. To permit a comparison between samples, the same sample weight, grading, number of spheres and number of revolutions must be used for all samples. The requested procedure will use a 5000 g sample, Grading A, 12 spheres and 500 revolutions (ASTM C131).

9. Conduct a test on aggregate soundness using a portion of material larger than the #4 sieve from Step 5 (ASTM C88). Use 5 cycles with magnesium sulfate solution.

10. Conduct descriptive tests on a portion of material larger than #4 sieve from Step 5. For visual inspection of angularity and sphericity, take at least 50 particles of a range of sizes. For hardness, follow ASTM-C235.

11. Tabulate test results with appropriate comments. Indicate any necessary deviations from the specified procedures. If these deviations are expected to change the results substantially they must be approved in advance. The samples should be saved until all results have been evaluated so that any required additional tests can be performed if needed.



## APPENDIX F

### METHODS AND APPARATUS FOR CYCLIC TRIAXIAL TESTING

The main requirement of the triaxial equipment is to subject cylindrical samples of ballast, subballast or subgrade, or composites of these materials, to cyclic or repeated stresses imposed by the passing trains in the field. These stresses are predicted by a multi-layer computer model that takes into consideration the effect of the ties and rails in distributing the wheel loads.

The complete state of strain, volume change and pore pressure as a function of time resulting from the applied stresses is to be measured.

An extensive amount of time was devoted to a literature review and discussions with experienced persons concerning the requirements of the cyclic triaxial system. The design of the system was specified based on the results of this effort. Because a suitable triaxial cell was not available commercially, a special cell was fabricated. The cell control system and the instrumentation were also designed and assembled.

Because it is necessary to characterize the behavior of the roadbed materials under time varying load, an important requirement of the cyclic system is a testing machine to produce and maintain the applied cyclic stress or strain over a large number of load applications. A summary of different systems for applying the load in stress controlled tests has

been presented by Brown (Ref. F-1). The principal systems are pneumatic (Ref. F-2), mechanical (Refs. F-3, F-4 and F-5), electrical (Ref. F-6), and hydraulic (Ref. F-7). These systems have been used for the testing of soils under repeated loading conditions and are usually purpose-built machines. Many of the existing systems have an uncertainty of loading over long duration tests and a lack of flexibility in application. The drawbacks of these systems are overcome by adopting servo-controlled hydraulic type of machines for soil testing. The most important feature is that programmed stress changes with time can be applied without being affected by changes in sample behavior during the test. In addition to this, any type of complex wave form of loading can be readily applied.

Among the important requirements selected for the triaxial cell were:

- 1) Sample size of at least 6 in. diameter.
- 2) Loading in extension and compression.
- 3) Controlled cell pressure and back pressure.
- 4) Pore pressure, volume change, lateral strain, axial strain and axial load monitoring.
- 5) Pore water flow for saturating samples.
- 6) Low friction resistance between oscillating load piston and cell chamber.
- 7) Provision for accurate alignment of specimen with top cap and actuator piston.

The resulting cyclic triaxial cell (Fig. F-1) consists of a 12-in. OD, 1/2-in. thick and 24-in. long cylindrical acrylic chamber which is sealed to 2-in. thick anodized aluminum cell top and base plates by means of rubber O-rings. The cell was designed for a maximum internal pressure of 160 psi and for 6-in. and 8-in. diameter soil samples with a H/D ratio of 2 to 2.5. Six 3/4-in. diameter stainless steel tension rods are used to compress the O-rings between the acrylic chamber and the plates. The tension rods are built inside the acrylic chamber to facilitate top cap alignment during sample preparation. The top of the cell is divided into two parts: 1) a top plate connected to the tension rods, and 2) a top collar for the acrylic chamber that is fixed to the top plate by means of screws. The specimen base pedestal and top cap are made of stainless steel.

The cell pressure and back pressure applied to the sample during testing are obtained from an air compressor by means of air-water interfaces created in reservoirs specifically designed and built for this purpose. The reservoirs have been designed for a maximum pressure of 160 psi. The air pressure cannot be applied directly to the sample because the rubber membranes in which the samples are enclosed are about ten thousand times more permeable to gases than to water.

With the use of reservoirs it is possible to pressurize the cell very quickly with water. The pressure may be maintained accurately for any desired period of time using air pressure regulators that maintain the desired pressures regardless of fluctuations in line pressure, provided that this does not fall too low. The air pressure regulators used have a maximum value of 160 psi and will maintain the pressure constant to within 0.01 psi.

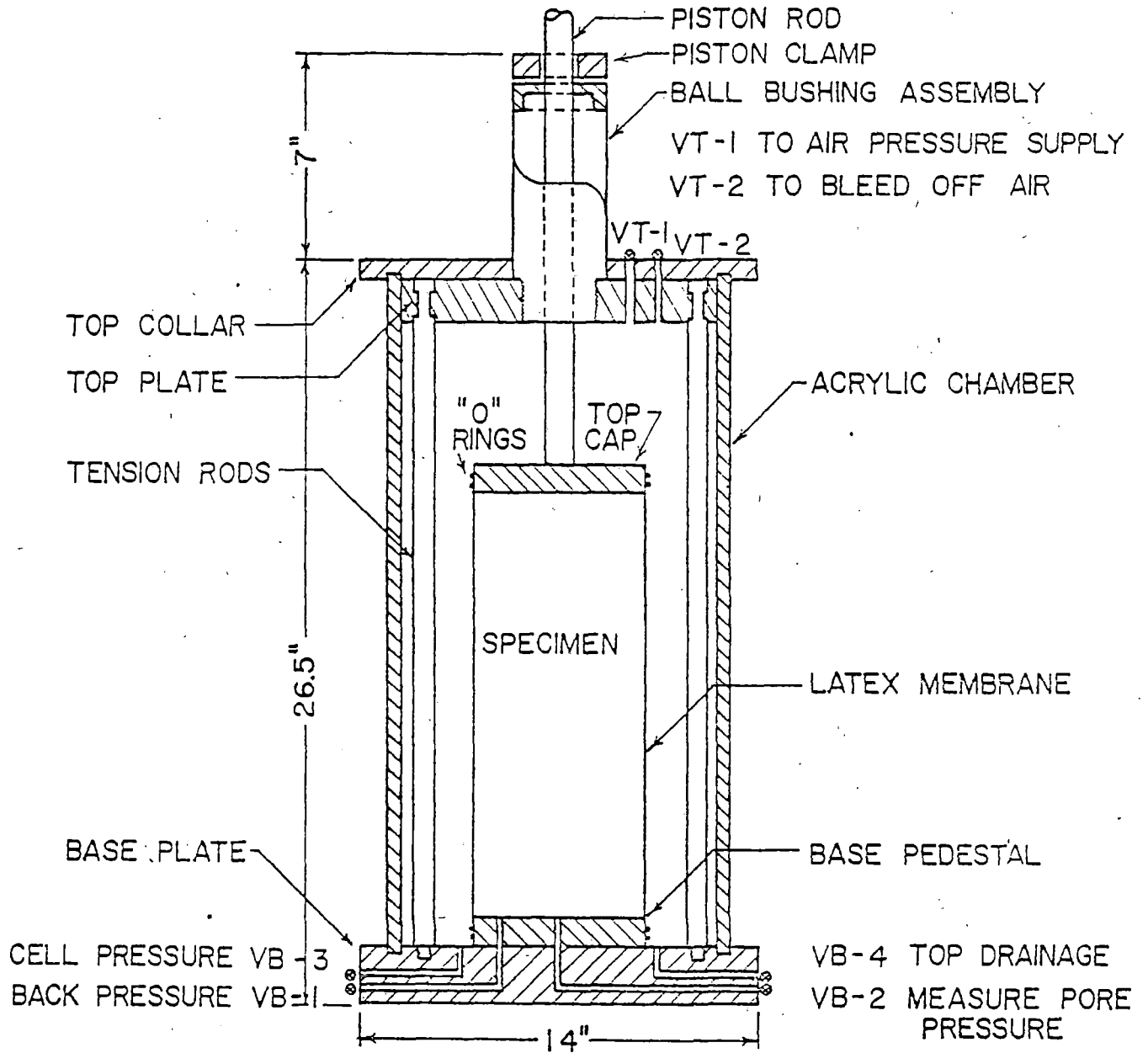

Fig. F-1. Ballast Cyclic Triaxial Cell

At the present time the UMASS cyclic testing facility is equipped with a static volume change device. An investigation has been made into the possibilities in the future of adding an automatic volume change device to the facility for cyclic loading (Ref. F-8).

The present volume change device is intended to be used in the consolidation stage of saturated samples of ballast, subballast or subgrade. During the cyclic or repeated loading stage it will not be possible to automatically record volume change in a drained test. For this purpose a different system is sought (Ref. F-8). At the present moment, a decision has not been made in relation to the fabrication or acquisition of an automatic volume change device for the purpose of cyclic testing of materials in a drained condition. Meanwhile, during the drained cyclic tests, it is planned to measure volume change by means of measuring the axial deformation with an LVDT and the lateral deformation either with soil strain gauges, (Ref. F-9), or by constructing a circumferential measuring device. There is also the alternative of using the static volume change device as a back-up system by stopping the test periodically and measuring the cumulative volume change.

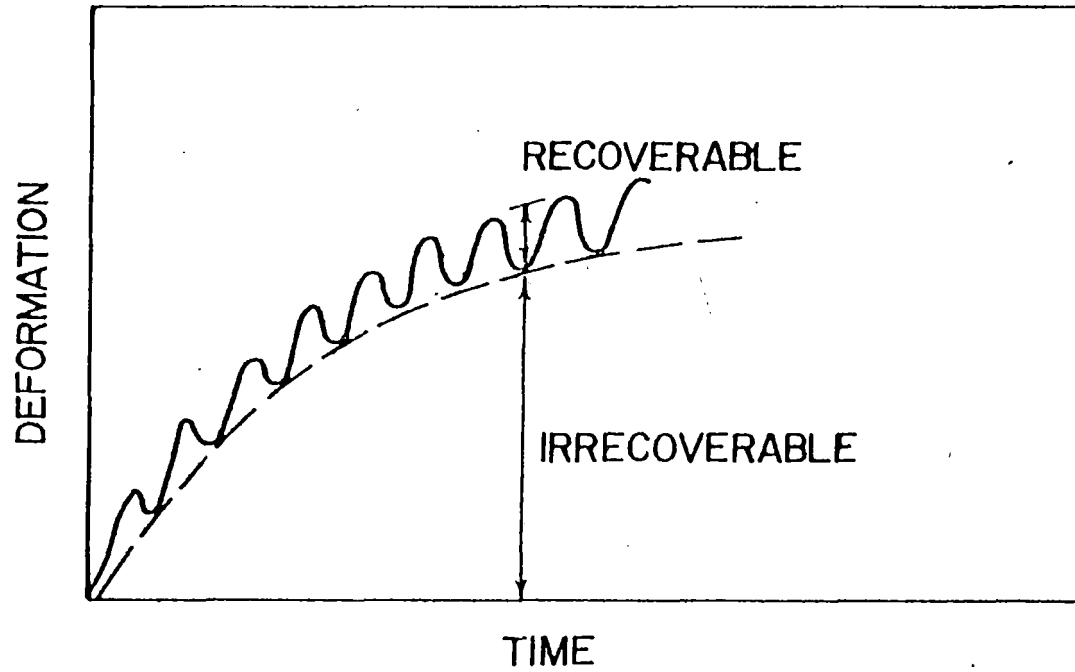

Fig. F-2. Variation of Deformation During A Repeated Load Test (Ref. 2-24)

The sample deformations will have two components: one irrecoverable or permanent, and the other of much smaller magnitude which is recoverable. This situation is depicted in Fig. 2-9 from Brown and Snaith(Ref. 2-24). The expected test duration is long (up to 100,000 cycles) and for this reason, together with the need to determine the dynamic, recoverable deformation component, measurements must be capable of automatic recording. The simplest method of obtaining a measurement of the vertical sample deformation is by an external displacement transducer or dial gauge monitoring the movement of the piston relative to the triaxial cell. The hydraulic actuator provides an LVDT signal that can be recorded for this purpose. In addition to the LVDT, a dial gauge is attached between the piston and top plate to monitor the axial deformation during sample setup and during consolidation, and permanent deformation at the end of the test. The LVDT system of measurement is subjected to error due to deformation in the loading frame that may be of the same order of magnitude as a typical resilient sample deformation. The dial gauge will help to indicate when these errors become significant.

The main purpose of the recording system is to have time plots of the outputs from the actuator load cell and LVDT through the servo-control panel, and also the time plots of the lateral strain and either the pore pressure or volume change depending upon whether the test is undrained or drained. A schematic of the instrumentation and recording system is presented in Figure F-3.

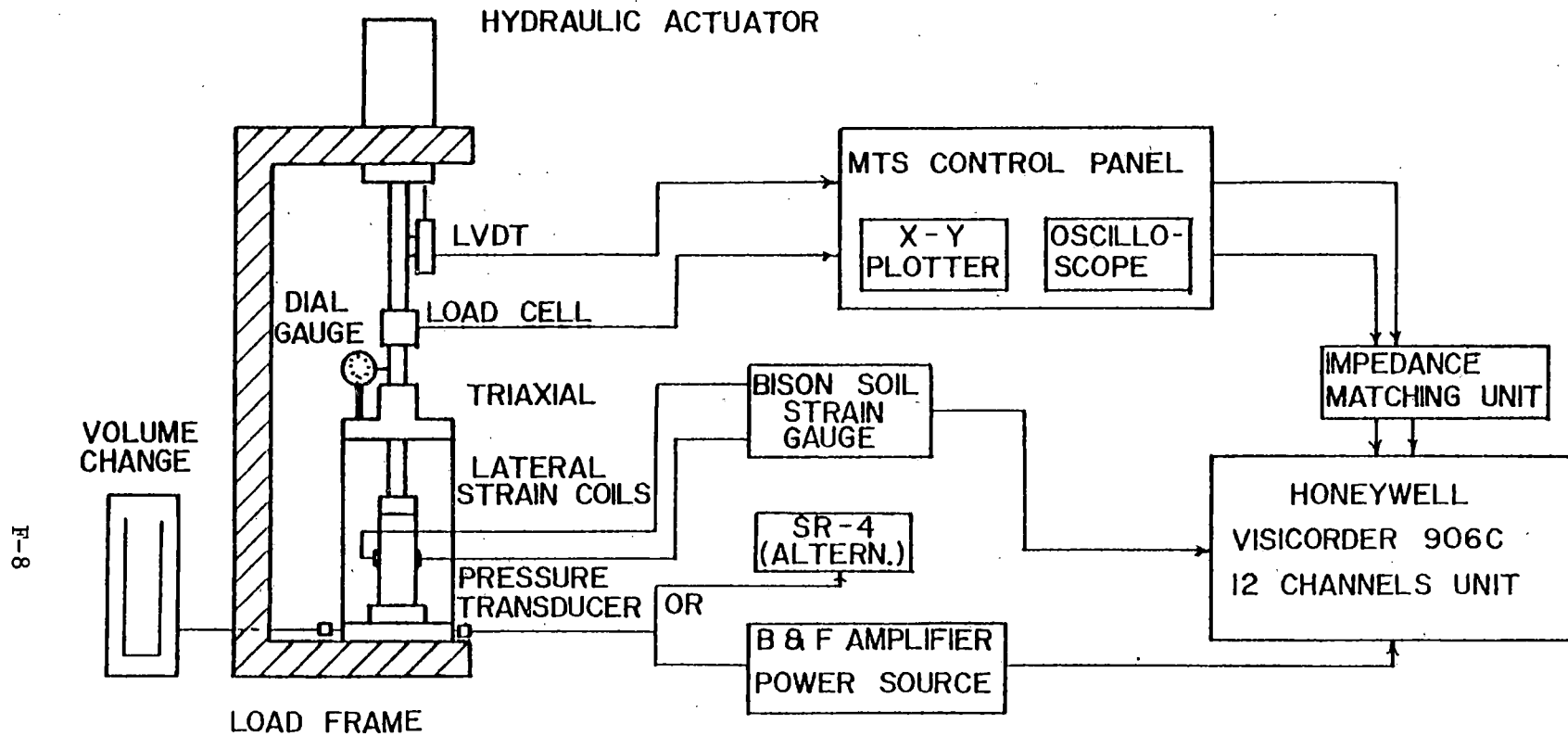

Fig. F-3. Schematic of Instrumentation and Recording System



## REFERENCES

- (F-1) Brown, S. F., "Laboratory Testing for Use in the Prediction of Rutting in Asphalt Pavements," Transportation Research Record, 616, TRB, National Academy of Sciences, 1976.
- (F-2) Seed, H. G., and McNeill, R., "Soil Deformations Under Repeated Stress Applications," ASTM, STP No. 232, pp. 177-196, 1958.
- (F-3) Grainger, G. D., and Lister, N. W., "A Laboratory Apparatus for Studying the Behavior of Soils Under Repeated Loading," Geotechnique, 12, 1, pp. 3-14, 1962.
- (F-4) Castro, Gonalo, "Liquefaction of Sands," Ph.D. Thesis, Harvard University, Cambridge, Mass., 1969.
- (F-5) Silva-Tulla, Francisco, "Predicting Settlement of Clay Foundations Subjected to Cyclic Loading," D. Sc. Thesis, MIT, Cambridge, Mass., 1977.
- (F-6) Weissmann, G. R., and Hart, R. R., "The Damping Capacity of Some Granular Soils," ASTM, STP No. 305, pp. 45-54, 1961.
- (F-7) Dunlap, Wayne A., "Deformation Characteristics of Granular Materials Subjected to Rapid, Repetitive Loading," Texas Transportation Institute, Texas A & M University, College Station, Texas, 1967.
- (F-8) Alva-Hurtado, Jorge E., "Automatic Volume Change Devices for SUNYAB Cyclic Triaxial Cell," SUNY at Buffalo, January, 1978.
- (F-9) Selig, E. T., "Soil Compaction Evaluation With Strain Measurement," Civil Engineering Department, SUNY at Buffalo, December, 1971.
- (F-10) Brown, S. F., and Snaith, M. S., "The Measurement of Recoverable and Irrecoverable Deformations in the Repeated Load Triaxial Test," Technical Notes, Geotechnique 24, pp. 255-259, 1974.

## APPENDIX G

### DESCRIPTION OF MULTA/GEOTRACK

Based on an evaluation of PSA, ILLITRACK and MULTA, a new model, GEOTRACK, which accounts for the stress-dependent nature of roadbed materials, has been developed. The model emphasizes the geotechnical aspects of track behavior. In addition to the more fundamental question of material modelling, certain other deficiencies were eliminated from the MULTA model. In order to obtain a more efficient and practical model, the following additional modifications were made:

1. The MULTA model presently repeats calculations of influence coefficients generated by loading on the 2nd to 5th tie segment. A study of the axisymmetric nature of the multilayer roadbed model shows that the same influence coefficients are generated for similar axisymmetric locations relative to each loaded segment. This repetition is eliminated in GEOTRACK by generating the influence coefficients for the 2nd to 5th segment loading from those of the 1st segment loading. This modification has reduced the input data by four-fifths.
2. The MULTA model computes parameters for only three depth locations with linear layers. GEOTRACK can compute results for six depth locations with five non-linear layers.
3. Truck loading (i.e., a pair of axles) constitutes the dominant cyclic frequency. Therefore, automatic superposition of adjacent axle loads is incorporated into the GEOTRACK model. The combined stress state is employed in the determination of the magnitude and directions of the principal stresses of the roadbed elements.

4. The BURMISTER and LAC codes are combined in GEOTRACK to form a single model, thus eliminating the need for two separate runs which for MULTA required an external computer tape.
5. Based on the track geometry information which is specified by the length of tie, tie spacing and number of ties, the radii locations of the points of interest where stress and displacement information are desired are computed automatically in GEOTRACK, thus eliminating the need for manual computation and reducing the input data requirements appreciably.

The resilient modulus of roadbed materials has been related to the stress state as follows:

$$E_r = f(\sigma_3, \sigma_d, \Theta) ,$$

where

$\sigma_3$  = the confining pressure,

$\sigma_d$  = the deviator stress,  $\sigma_1 - \sigma_3$  ,

$\Theta = \sigma_1 + \sigma_2 + \sigma_3$  = sum of the principal stresses.

Due to the different effects of  $\Theta$  and  $\sigma_d$  the resilient modulus of soils may increase or decrease with stresses depending on the type of soil. It has been found experimentally that for granular materials,  $\Theta$  has a greater effect than  $\sigma_d$ , and the modulus increases with  $\Theta$  according to:

$$E_r = K_1 \Theta^{K_2} ,$$

where  $E_r$  = resilient modulus,

$\Theta$  = the bulk stress =  $\sigma_1 + \sigma_2 + \sigma_3$  ,

$\sigma_1, \sigma_2, \sigma_3$  = the major, intermediate and minor principal stress, respectively,

$K_1, K_2$  = experimentally determined constants.

On the other hand, for fine-grained materials,  $\sigma_d$  has a greater effect than  $\Theta$  and the modulus generally decreases with increase in  $\sigma_d$ .

The GEOTRACK model incorporates realistic non-linear characteristics of the roadbed materials. The general logic of modelling is the same as for MULTA.

Figure 1 shows the geometrical representation of the track structure in the GEOTRACK model. The roadbed is represented as a number of layers of finite thickness, the last layer being semi-infinite. The rails are assumed to be supported over a finite number of ties, say, eleven. If the track section is symmetric about the center tie and symmetry of loading on both rails is assumed, only one-quarter of the total track section, as shown in Fig. 1, need be specified.

The BURMISTER Code based on Burmister's three-dimensional elasticity solution of multilayer system is employed in determining the influence coefficients for the desired points of interest in the roadbed. Usually points along the ties at the centers of each tie segment, and midway between ties (forming a grid as shown in Fig. 2) and at some depth locations directly under the surface points are taken as the desired points of interest. Each point of interest is identified by coordinate  $(r, \theta, Z)$ .

The influence coefficients are obtained by loading each of the tie segment equivalent circular areas with a unit load, with no load on the other segment areas. A study of Fig. 2 reveals the axisymmetric nature of the problem--at a particular depth level in the roadbed, all points which are at the same relative radii locations to the loaded segment would have the same stress and displacement influence coefficients. Therefore, in the GEOTRACK model, the influence coefficients for loading on the 2nd to 5th segment are generated from those of the first.

The influence coefficients are first calculated in cylindrical coordinates and then transformed into Cartesian coordinates for use with the LOAD and COMBINATION code. Figure 3 shows the transformation from cylindrical  $(R, \theta, Z)$ , to the Cartesian  $(X, Y, Z)$  system.

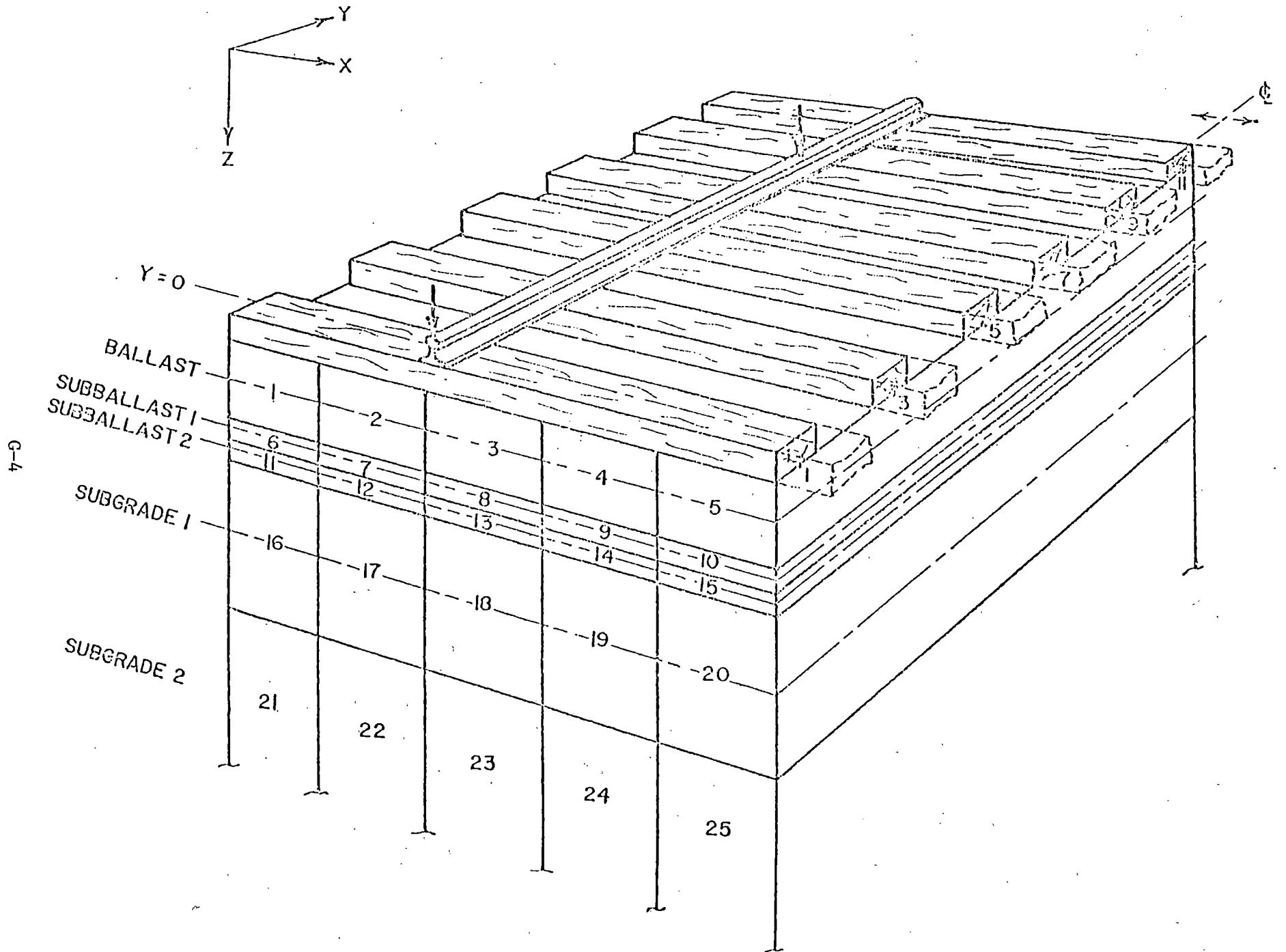

Fig. 1. Geometrical Representation of GEOTRACK Model.

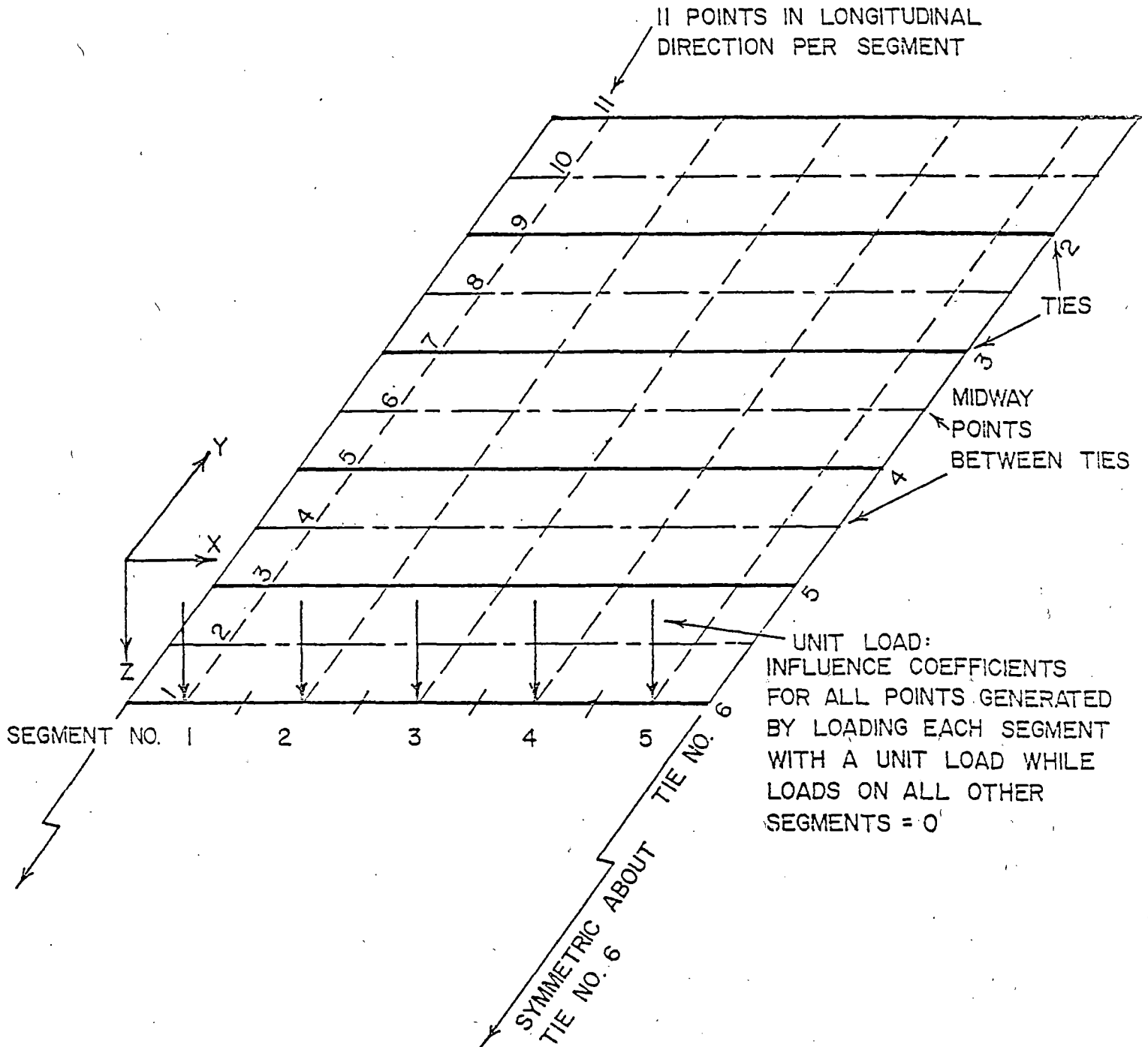
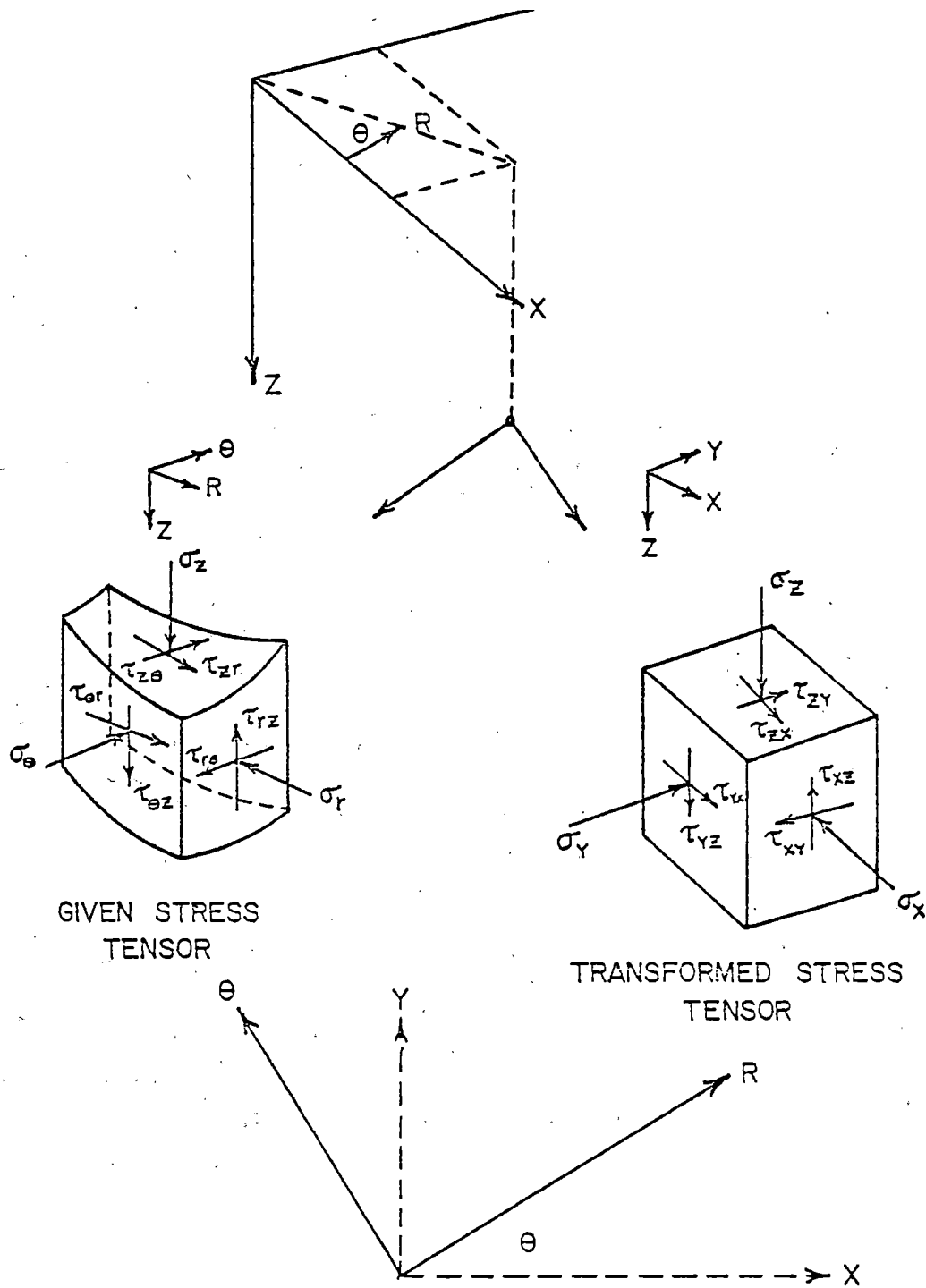

Fig. 2. Illustration of Supporting Ties, Loaded Segments, and Points of Interest



|   | R        | $\theta$ | Z        |
|---|----------|----------|----------|
| X | $a_{11}$ | $a_{12}$ | $a_{13}$ |
| Y | $a_{21}$ | $a_{22}$ | $a_{23}$ |
| Z | $a_{31}$ | $a_{32}$ | $a_{33}$ |

⇒

|   | R            | $\theta$      | Z |
|---|--------------|---------------|---|
| X | $\cos\theta$ | $-\sin\theta$ | 0 |
| Y | $\sin\theta$ | $\cos\theta$  | 0 |
| Z | 0            | 0             | 1 |

Fig. 3. Transformation of Stress Tensor From Cylindrical to Cartesian System

The components of the stress tensor are input into an eigen vector routine to determine the magnitude and directions of the principal stresses.

Since, as established earlier, the resilient moduli of roadbed materials are stress dependent and the stresses themselves are functions of the moduli, a compatible solution requires successive iterations.

The iterative procedure, which is one of the methods of approximating nonlinear material properties, is employed in the GEOTRACK model. It consists of solving the same problem repeatedly under the full load, choosing for successive solutions a value of resilient modulus for each layer corresponding to an average effective state of stress calculated for the layer in the preceding cycle. Thus in each iteration,

$$(E_r)_{i+1} = E_r (\sigma_{ij})_i ,$$

where  $(E_r)_{i+1}$  = new  $E_r$  for the  $(i+1)^{th}$  iteration,

$(\sigma_{ij})_i$  = stress state in the  $i^{th}$  iteration.

The iteration is continued until  $(E_r)_{i+1} - (E_r)_i \leq \epsilon$  where  $\epsilon$  is the tolerance of convergence. The final stresses and displacements are those obtained in the  $(i+1)^{th}$  iteration. In each iteration, the materials are treated as linearly elastic with  $E$  and  $\nu$  replaced with the values consistent with the current state of stress in accordance with the nonlinear relation between modulus and stress state.

Because of the problems associated with measuring accurate values of  $\nu$ , as well as the fact that the response of the pavement and track systems is relatively insensitive to reasonable variations of  $\nu$ , estimated and constant values of  $\nu$  are often used as engineering approximation.

The following procedures are carried out in the iterative scheme employed in the GEOTRACK model:

1. Previous study has shown that the incremental bulk stress,  $\Delta\theta$ , due to train loads does not vary appreciably across the tie. But there is a significant variation of  $\Delta\theta$  in the vertical direction.



In order to account for variation of  $\Delta\theta$  with depth more realistically, the roadbed system is divided into five layers; ballast layer, subballast 1, subballast 2, subgrade 1 and subgrade 2 as shown in Fig. 1.

2. Stress states are computed at 55 locations (Figs. 1 & 2) at the center of each layer. Each layer is considered to be composed of 5 "elements"--one element under each tie segment extending in length along the longitudinal rail direction (Y-axis). Thus for each element, stress states are computed at 11 locations along its length.

3. Geostatic bulk stress is computed at the center of each layer as

$$\theta_o = \bar{\sigma}_{vo} + 2K_o \bar{\sigma}_{vo} = (1+2K_o) \bar{\sigma}_{vo} ,$$

where  $\theta_o$  = geostatic bulk stress,

$\bar{\sigma}_{vo}$  = geostatic vertical effective stress,

$K_o$  = coefficient of lateral stress at rest.

4. The final bulk stress at each of the 11 longitudinal locations on each element is computed as

$$\theta_f = \theta_o + \Delta\theta ,$$

where  $\theta_f$  = final bulk stress,

$\Delta\theta$  = incremental bulk stress due to train loads =  $\Delta\sigma_1 + \Delta\sigma_2 + \Delta\sigma_3 =$

$$\Delta\sigma_x + \Delta\sigma_y + \Delta\sigma_z .$$

5. In order to take into account the stress states in each element at locations other than the loaded tie ( $Y = 0$ ), i.e. the longitudinal variation of  $\theta$ , a weighted average using the rail-seat load under each tie as the weighting factor is employed.
6. The average  $\theta$  for a layer is then obtained as a straight average of the  $\theta$ 's for the five elements.
7. The representative modulus for each layer is obtained by using  $E_r = K_1 \theta^{K_2}$ ,  $K_1, K_2$  being the parameters for each particular layer.

8. For the track sections analyzed in this study, the resilient moduli have converged substantially at the end of three iterations, as will be shown later.

In the fourth iteration, the stress and displacement values are obtained at the interface locations or any other depth location rather than at the middle of the layers; the resilient moduli obtained in the third iteration being employed in the 4th and final iteration.

\* U.S.G.P.O. 620-941/1302-822

REPORT OF NEW TECHNOLOGY

This report presents an experiment plan and a correlation analysis methodology through the long-term performance of concrete tie track will be evaluated. The report includes descriptions of measurements devices, instrumentation and data acquisition systems which represent the state of the art in the evaluation of dynamic loads, strains and accelerations, and the physical and chemical states of ballast, subballast and subgrade. However, a careful review of the work presented here indicates that no new inventions, discoveries or improvements of inventions were made.

Measurement and Correlation Analysis Plan  
**Measurement and Correlation Analysis Plan  
for Concrete Tie and Fastener Performance  
Analysis (Interim Report), 1979**  
US DOT, FRA

PROPERTY OF FEA  
RESEARCH & DEVELOPMENT  
LIBRARY