

REPORT NO. UMTA-MA-06-0025-79-3,I

SLRV ENGINEERING TESTS AT DEPARTMENT OF TRANSPORTATION
TRANSPORTATION TEST CENTER
FINAL TEST REPORT
Volume 1 - Introduction

Prepared by
Boeing Vertol Company
Surface Transportation Systems
Philadelphia, PA 19142



JUNE 1979

FINAL REPORT

DOCUMENT IS AVAILABLE TO THE PUBLIC
THROUGH THE NATIONAL TECHNICAL
INFORMATION SERVICE, SPRINGFIELD,
VIRGINIA 22161

Prepared for
U.S. DEPARTMENT OF TRANSPORTATION
URBAN MASS TRANSPORTATION ADMINISTRATION
Office of Technology Development and Deployment
Office of Rail and Construction Technology
Washington, D.C. 20590

NOTICE

This document is disseminated under the sponsorship of the Department of Transportation in the interest of information exchange. The United States Government assumes no liability for its contents or use thereof.

NOTICE

The United States Government does not endorse products or manufacturers. Trade or manufacturers' names appear herein solely because they are considered essential to the object of this report.

1. Report No. UMTA-MA-06-0025-79-3, I		2. Government Accession No.		3. Recipient's Catalog No.	
4. Title and Subtitle SLRV Engineering Tests at Department of Transportation Transportation Test Center Volume I--Introduction				5. Report Date February 1979	
				6. Performing Organization Code 8-2700	
7. Author(s)				8. Performing Organization Report No. DOT-TSC-UMTA-79-27, I	
9. Performing Organization Name and Address The Boeing Vertol Company* Surface Transportation Systems Branch P.O. Box 16858 Philadelphia PA 19142				10. Work Unit No. (TRAIS) UM904/R9731	
				11. Contract or Grant No. DOT-TSC-1062	
12. Sponsoring Agency Name and Address Department of Transportation Urban Mass Transportation Administration Office of Technology Development and Deployment, Office of Rail and Construction Technology, Washington DC 20590				13. Type of Report and Period Covered Final Report Jan--June 1976	
				14. Sponsoring Agency Code UTD-30	
15. Supplementary Notes U.S. Department of Transportation *Under contract to: Research and Special Programs Administration Transportation Systems Center Kendall Square, Cambridge, MA 02142					
16. Abstract In May 1973, Boeing Vertol Company was awarded a contract to build Light Rail Vehicles to a specification sponsored by Department of Transportation's Urban Mass Transportation Administration, and identified a Standard Light Rail Vehicle (SLRV). Engineering testing on the SLRV was conducted by Boeing Vertol Company in accordance with the General Vehicle Test Plan GSP-064 at the Transportation Test Center, Pueblo, Colorado. The tests were conducted in conjunction with the Qualification Testing of three SLRV Production Pilot Cars (SF-0002, SF-0003, and MB-0002). This report presents the results of the series of tests conducted in accordance with GSP-064. Volume I contains a description of the SLRV Test Program and the vehicle, and a summary of the test results; Volume II, Performance and Power Consumption Test Data; Volume III, Ride Quality, Noise, and Radio Frequency Interference Test Data; and Volume IV, a log of all tests collated by test objective and test vehicle.					
17. Key Words General Vehicle Tests Light Rail Vehicle Transportation Test Center			18. Distribution Statement DOCUMENT IS AVAILABLE TO THE U.S. PUBLIC THROUGH THE NATIONAL TECHNICAL INFORMATION SERVICE, SPRINGFIELD, VIRGINIA 22161		
19. Security Classif. (of this report) Unclassified		20. Security Classif. (of this page) Unclassified		21. No. of Pages 72	22. Price

BACKGROUND AND SUMMARY

In 1972 the U.S. Department of Transportation's Urban Mass Transportation Administration (UMTA), through its Office of Technology Development and Deployment, Office of Rail and Construction Technology, sponsored a program to develop specifications for a new Standard Light Rail Vehicle (SLRV). The objective was to prepare coordinated specifications for an optimum Light Rail Vehicle based on available technology to replace the President's Conference Committee (PCC) cars and provide a vehicle for new Light Rail Transit systems.

The following groups joined with UMTA in developing the SLRV specification.

Massachusetts Bay Transportation Authority
San Francisco Municipal Railway
Southeastern Pennsylvania Transportation Authority
Shaker Heights Rapid Transit
Port Authority of Allegheny County
Transport of New Jersey
El Paso City Lines
Toronto Transit Commission
Parsons Brinckerhoff – Tudor – Bechtel
Louis T. Klauder and Associates

In May 1973 the Boeing Vertol Company was awarded a contract to design and manufacture SLRVs for the Massachusetts Bay Transportation Authority (MBTA) and the San Francisco Municipal Railway (SFMR). Qualification testing of the production cars was carried out at the Boeing Vertol Company facility, and at the UMTA Transportation Test Center, Pueblo, Colorado and at the operating properties in Boston and San Francisco. Three production pilot cars (2 SFMR and 1 MBTA) were shipped to Pueblo in 1976 for run testing on the Rail Transit Track (RTT) in accordance with Boeing Vertol specification D334-10059-1.¹ At this time a requirement was established within the DOT Transportation Systems Center (TSC) for a data base on the SLRV for quantitative comparison purposes in the Urban Rail Test and Evaluation Program. Comparison of the requirements of the Boeing Vertol specification D334-10059-1 and the TSC General Vehicle Test Plan (GSP-064) disclosed that common data requirements existed, particularly in the sections dealing with single car testing.

In June 1976, therefore, the DOT Transportation Systems Center awarded a contract (DOT-TSC-1062) to the Boeing Vertol Company to perform engineering testing on the SLRV in accordance with GSP-064. Testing was carried out on the production pilot cars being operated at Pueblo for production qualification testing. In cases where common data requirements existed, the GSP-064 testing was conducted in conjunction with the appropriate sections of the qualification test program, thus minimizing the cost of the GSP-064 testing.

This report presents the result of these tests conducted in accordance with GSP-064 on the SLRV at the Transportation Test Center, Pueblo, Colorado by Boeing Vertol Company under contract to the DOT Transportation System Center.

1. Standard Light Rail Vehicle Test Procedures, Boeing Vertol Company, D334-10059-1.

Approximate Conversions to Metric Measures

Symbol	When You Know	Multiply by	To Find	Symbol
<u>LENGTH</u>				
in	inches	* 2.5	centimeters	cm
ft	feet	30	centimeters	cm
yd	yards	0.9	meters	m
mi	miles	1.6	kilometers	km
<u>AREA</u>				
in ²	square inches	6.5	square centimeters	cm ²
ft ²	square feet	0.09	square meters	m ²
yd ²	square yards	0.8	square meters	m ²
mi ²	square miles	2.6	square kilometers	km ²
	acres	0.4	hectares	ha
<u>MASS (weight)</u>				
oz	ounces	28	grams	g
lb	pounds	0.45	kilograms	kg
	short tons (2000 lb)	0.9	tonnes	t
<u>VOLUME</u>				
tsp	teaspoons	5	milliliters	ml
Tbsp	tablespoons	15	milliliters	ml
fl oz	fluid ounces	30	milliliters	ml
c	cups	0.24	liters	l
pt	pints	0.47	liters	l
qt	quarts	0.95	liters	l
gal	gallons	3.8	liters	l
ft ³	cubic feet	0.03	cubic meters	m ³
yd ³	cubic yards	0.76	cubic meters	m ³
<u>TEMPERATURE (exact)</u>				
°F	Fahrenheit temperature	5/9 (after subtracting 32)	Celsius temperature	°C

* 1 in = 2.54 cm (exactly). For other exact conversions and more detailed tables, see NBS Misc. Pub. 286, Units of Weights and Measures, Price \$2.25, SD Catalog No. C13.10:286.

METRIC CONVERSION FACTORS

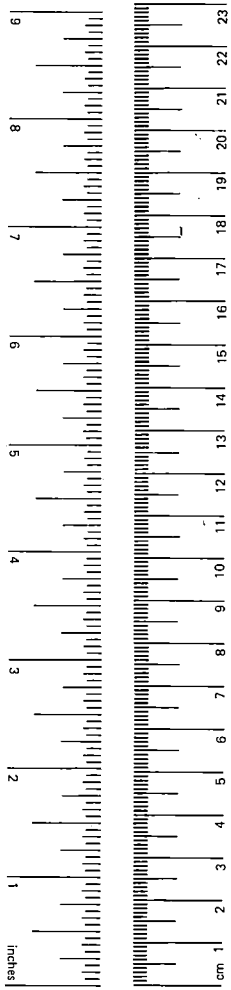

Approximate Conversions from Metric Measures

Symbol	When You Know	Multiply by	To Find	Symbol
<u>LENGTH</u>				
mm	millimeters	0.04	inches	in
cm	centimeters	0.4	inches	in
m	meters	3.3	feet	ft
m	meters	1.1	yards	yd
km	kilometers	0.6	miles	mi
<u>AREA</u>				
cm ²	square centimeters	0.16	square inches	in ²
m ²	square meters	1.2	square yards	yd ²
km ²	square kilometers	0.4	square miles	mi ²
ha	hectares (10,000 m ²)	2.5	acres	
<u>MASS (weight)</u>				
g	grams	0.035	ounces	oz
kg	kilograms	2.2	pounds	lb
t	tonnes (1000 kg)	1.1	short tons	
<u>VOLUME</u>				
ml	milliliters	0.03	fluid ounces	fl oz
l	liters	2.1	pints	pt
l	liters	1.06	quarts	qt
l	liters	0.26	gallons	gal
m ³	cubic meters	35	cubic feet	ft ³
m ³	cubic meters	1.3	cubic yards	yd ³
<u>TEMPERATURE (exact)</u>				
°C	Celsius temperature	9/5 (then add 32)	Fahrenheit	°F

TABLE OF CONTENTS

<u>Section</u>	<u>Page</u>
1. INTRODUCTION	1-1
1.1 SLRV Engineering Test Program	1-1
1.2 The U.S. Standard Light Rail Vehicle (SLRV)	1-1
1.3 Test Site	1-11
1.4 General Vehicle Test Plans	1-19
1.5 Test Operations	1-19
2. TEST DESCRIPTION	2-1
2.1 Objectives and Summary Description	2-1
2.2 Test Sets	2-1
2.3 Instrumentation	2-4
3. TEST RESULTS	3-1
3.1 Summary	3-1
3.2 Results	3-1
APPENDIX A – TEST SET COVER SHEETS SHOWING TEST STATUS	A-1
APPENDIX B – PATENTS DISCLAIMER	B-1

LIST OF ILLUSTRATIONS

<u>Figure</u>	<u>Page</u>
1-1 U.S. Standard Light Rail Vehicle	1-2
1-2 View of Passenger Area – SFMR Car	1-4
1-3 MBTA Car on Track	1-6
1-4 SFMR Car on Track	1-7
1-5 SLRV Design and Performance Characteristics	1-8
1-6 SLRV Operating Profile	1-9
1-7 SLRV Test Cars in Maintenance Building	1-12
1-8 UMTA Rail Transit Test Track	1-13
1-9 Rail Transit Test Track Profile Showing Grades	1-14

<u>Figure</u>		<u>Page</u>
1–10	SLRV on Test Track Showing Catenary, Support and Jumper Wiring	1–16
1–11	View of Catenary From SLRV Cab	1–17
1–12	Alternator Characteristics of Locomotive Used for Power Source	1–18
1–13	General Vehicle Test Set – Example	1–20
1–14	SLRV Test Cards	1–22
2–1	Instrumentation Installation on SF-0002	2–5
2–2	Instrumentation Block Diagram	2–7
3–1	Effect of Line Voltage on Acceleration	3–2
3–2	Effect of Car Weight on Acceleration	3–2
3–3	Effect of Control Setting on Acceleration	3–3
3–4	Control Linearity	3–4
3–5	Traction Resistance	3–5
3–6	Power Consumption on Simulated N-Line Operation	3–7
3–7	Ride Quality Baseline Comparison – Effect of Speed	3–8
3–8	Effect of Speed on End Car Centerline Lateral Ride Roughness	3–10
3–9	Effect of Speed on End Car Centerline Vertical Ride Roughness	3–10
3–10	Ride Quality Baseline Comparison – Effect of Car Weight	3–11
3–11	Effect of Speed on Wayside Noise	3–12
3–12	Effect of Vehicle Speed on Wayside Noise	3–12
3–13	Noise Levels Versus Speed – Non-Air-Conditioned Car	3–13
3–14	Noise Levels Versus Speed – Air-Conditioned Car	3–13

LIST OF TABLES

<u>Table</u>		<u>Page</u>
1-1	Configuration Comparison	1-5
1-2	RTTT Catenary Profile for SLRV Testing	1-15
2-1	Summary of SLRV Engineering Tests	2-2
2-2	SLRV Instrumentation Legend	2-6
2-3	Data Conditioning and Acquisition Equipment	2-8
2-4	Performance Test Instrumentation	2-9
2-5	Ride Quality Instrumentation	2-10
2-6	Instrumentation for RFI Tests	2-11
3-1	Summary of Wheel Spin/Slide Efficiencies	3-6

1. INTRODUCTION

The United States Standard Light Rail Vehicle (SLRV) is currently in production at the Boeing Vertol Company for the Massachusetts Bay Transportation Authority and the San Francisco Municipal Railway. In order to develop a data base for quantitative comparison of the SLRV with other railcars and systems, testing was performed at the Rail Transit Test Track at Pueblo to the requirements of the TSC General Vehicle Test Plans (GSP-064).²

This report, together with the additional available data stored in the TSC magnetic tape records, provides a baseline of data for light rail vehicles against which later modifications to these vehicles or other new vehicles may be compared.

1.1 SLRV ENGINEERING TEST PROGRAM

The general objective of the SLRV engineering test program was to:

Establish a data baseline for the SLRV obtained in accordance with the General Vehicle Test Plans.

Provide further experience in the use of the General Vehicle Test Plans in testing Urban Rail Vehicles.

This report of the SLRV Engineering Tests is contained in four volumes:

- Volume I Introduction
- Volume II Performance and Power Consumption Tests
- Volume III Ride Quality, Noise, and Radio Frequency Interference Tests
- Volume IV Data Logs

1.2 THE U.S. STANDARD LIGHT RAIL VEHICLE (SLRV)

The SLRV (Figure 1-1) is a 71 foot vehicle, articulated to negotiate curves down to 32-foot radius and designed to operate at speeds up to 50 mph. Although the basic configuration and performance is standardized, the current operating properties (Massachusetts Bay Transportation Authority and San Francisco Municipal Railway) have specified individual requirements for auxiliary equipment and passenger accommodation.

A brief description of the vehicle and subsystems is given below. A detailed description may be found in the Standard Light Rail Vehicle Specification, Technical Section.³

-
2. General Vehicle Test Plans for Urban Rapid Transit Cars, UMTA-MA-06-0025-75-14, NTIS Report PB-251-086.
 3. Standard Light Rail Vehicle Specification, UMTA-MA-06-0015-72-4, NTIS Report PB-220-748, 1972.

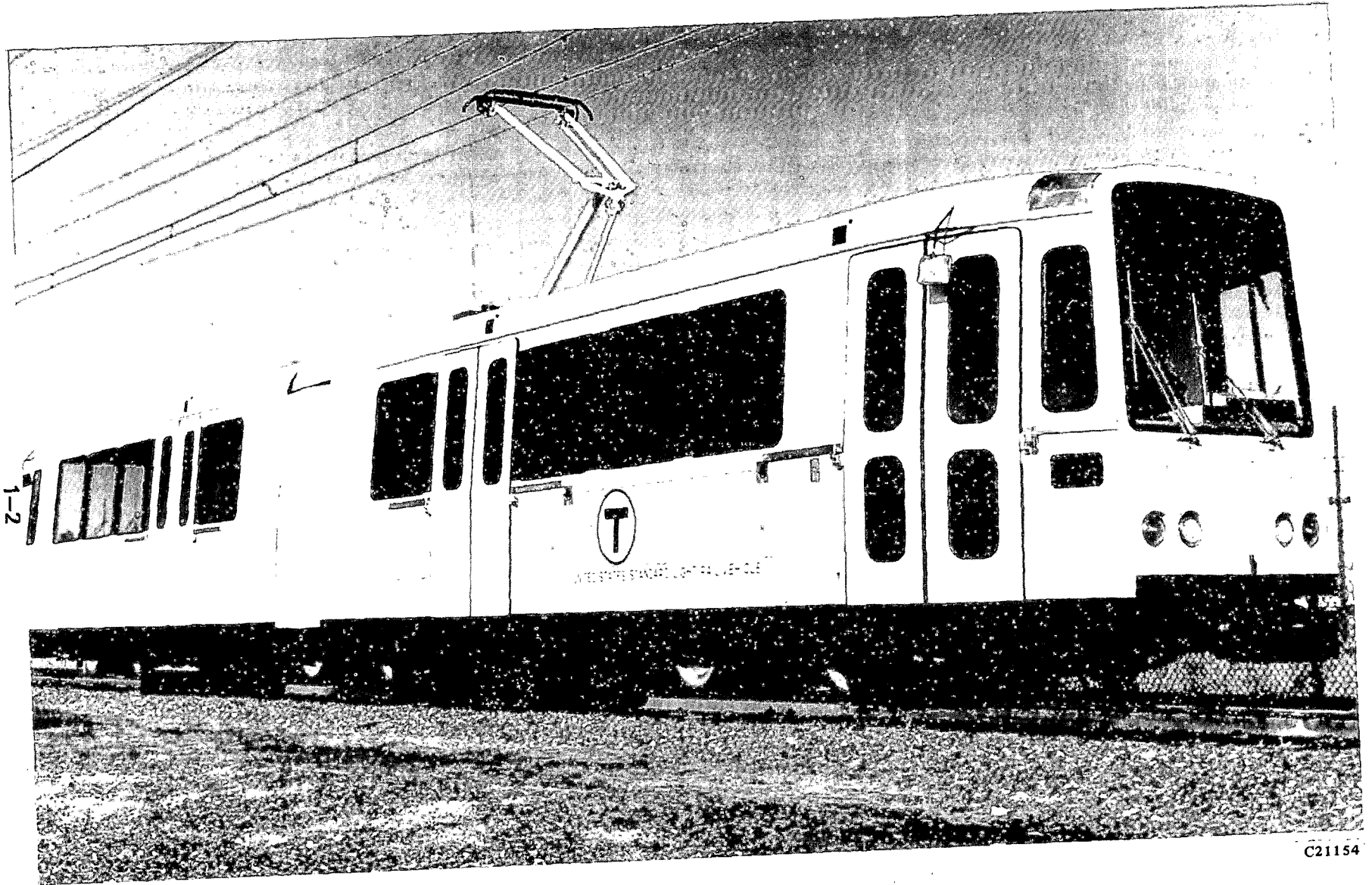

C21154

Figure 1-1. U.S. Standard Light Rail Vehicle

General

Each car consists of three sections, an "A" section, a "B" section and an articulation section. In general, each car is an all-welded, low alloy high tensile steel structure with the central roof skin of stainless steel. The shell of the articulation section is primarily of fiberglass. There are three trucks, two being located 13-1/2 feet from each end with the third one positioned under the centerline of the articulation section. The car is 71 feet long and 8 feet 10-1/4 inches wide, with three 53-inch passenger doors along each side. The MBTA cars contain 52 molded seats with a total capacity of 219 passengers while the SFMR cars contain 68 seats for the same total capacity (see Figure 1-2). The MBTA cars have fixed, low level steps for street loading at each passenger door; however, the SFMR cars are equipped with moveable steps at four door locations, to accommodate street or platform loading (see Table 1-1, Configuration Comparison). MBTA and SFMR cars on the TTC track are shown in Figures 1-3 and 1-4 respectively. Figure 1-5 shows salient design and performance characteristics.

Propulsion System

The propulsion system is of the monomotor truck configuration, with each end truck having a resiliently mounted DC motor. The center truck is unpowered. The two 285 VDC monomotors are rated at 210 horsepower, 168 kw at 1135 rpm (continuous), they are fully compensated for optimum commutation and are electrically connected in series. The drive to the axle is through right angle single hypoid gear sets with an overall gear ratio of 5.571:1.

Power modulation in both propulsion and braking modes is accomplished by a solid state (thyristor) DC chopper control.

The armature voltage is controlled by a single 600 VDC to DC force commutated chopper with fixed or variable frequency and fixed or variable pulse width depending on the power demand. The field voltage is controlled by a separate 600 VDC to DC chopper with variable frequency and fixed pulse width. Power to the vehicle is supplied by a pantograph through an inrush limiter and line filter. Auxiliary (37.5 VDC) power is supplied by a solid state converter with a backup 120 amp-hour nickel cadmium battery. Control subsystems provide for load weight, jerk rate, wheel spin/slide control and dynamic-friction brake blending. The SLRV operating profile is shown in Figure 1-6.

Braking System

The major braking effort of the SLRV is provided by the dynamic braking capability of the propulsion system under normal service operating conditions. Two brake resistor grids provide the electrical load for the traction motors acting as generators during dynamic braking efforts, a friction brake system is available for blending with the dynamic braking. The friction brake also provides a parking brake capability which will hold an AW3 loaded car on a 9° slope. (See Test Vehicle Configuration on 1-10).

The friction brake system is a pneumatic-hydraulic system employing one inboard disc and caliper unit per axle (a total of six per car), a pneumatic-hydraulic boost assembly mounted on the underframe adjacent to each truck, and one control unit per car to accomplish service

1-4

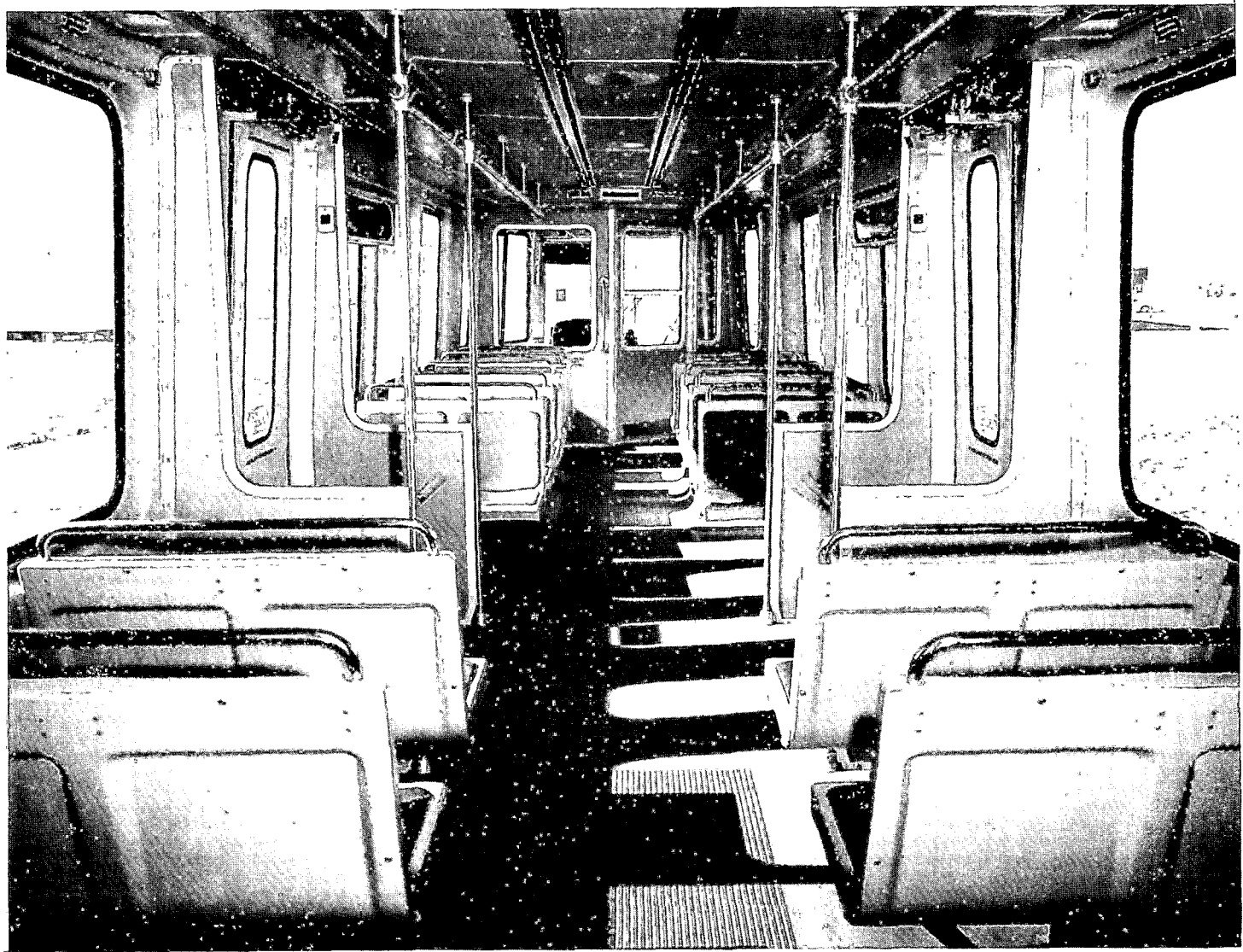

C25152

Figure 1-2. View of Passenger Area – SFMR Car

TABLE 1-1: CONFIGURATION COMPARISON

Item	MBTA	SFMR
Passenger Seating	52	68
Cab Signalling	No	Yes
Steps	Fixed, low level	Convertible high-low on four center doors
Overspeed Control	Yes (52 mph limit)	No
Destination Signs	Manual	Automatic
Air Conditioning	Yes – Single blower speed	No – Three speed air comfort blower
Full Service Blended Braking with Track Brake	Yes	No
Wheels	1:40 Tread contour	1:20 Tread contour

1-6

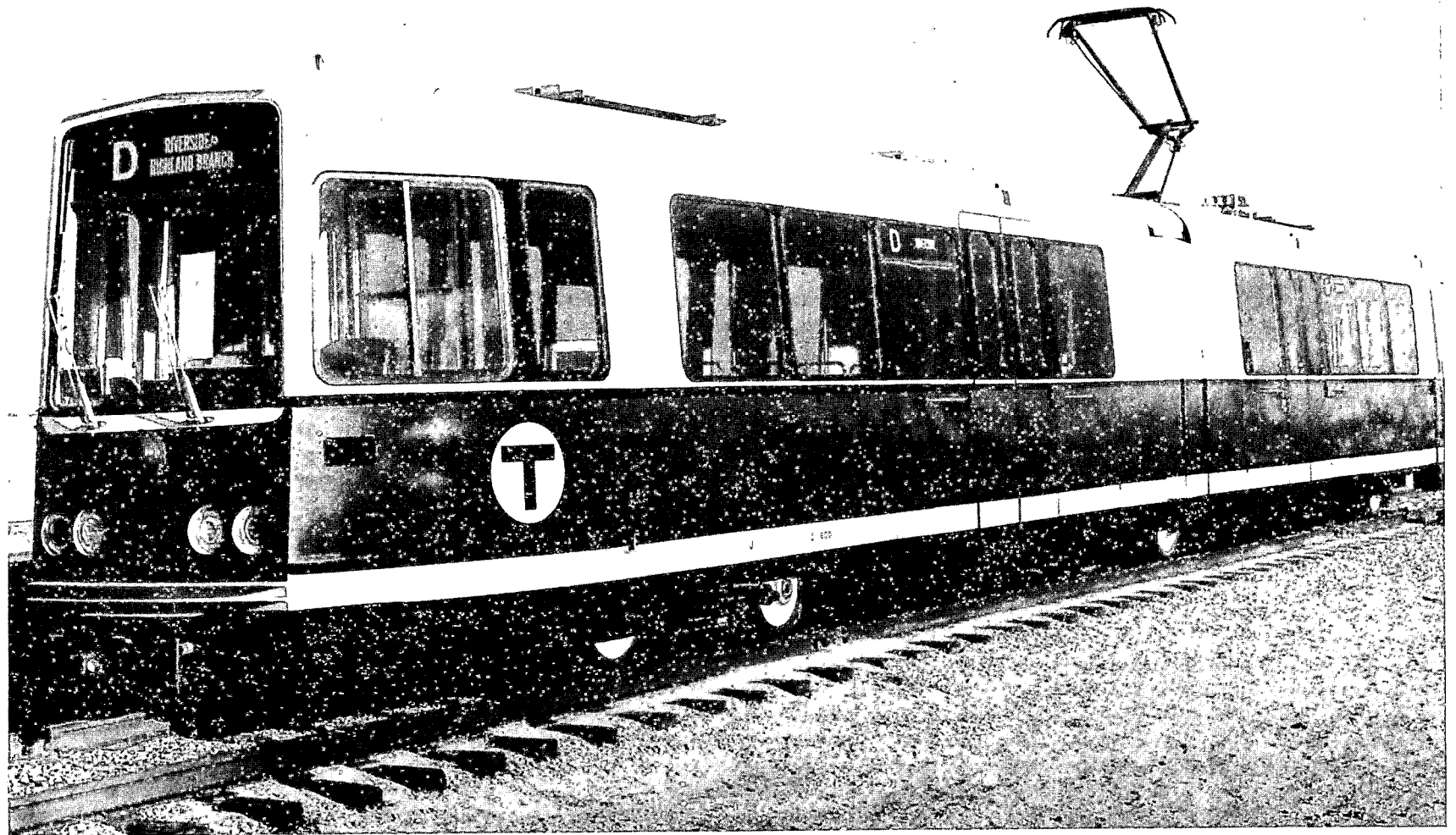
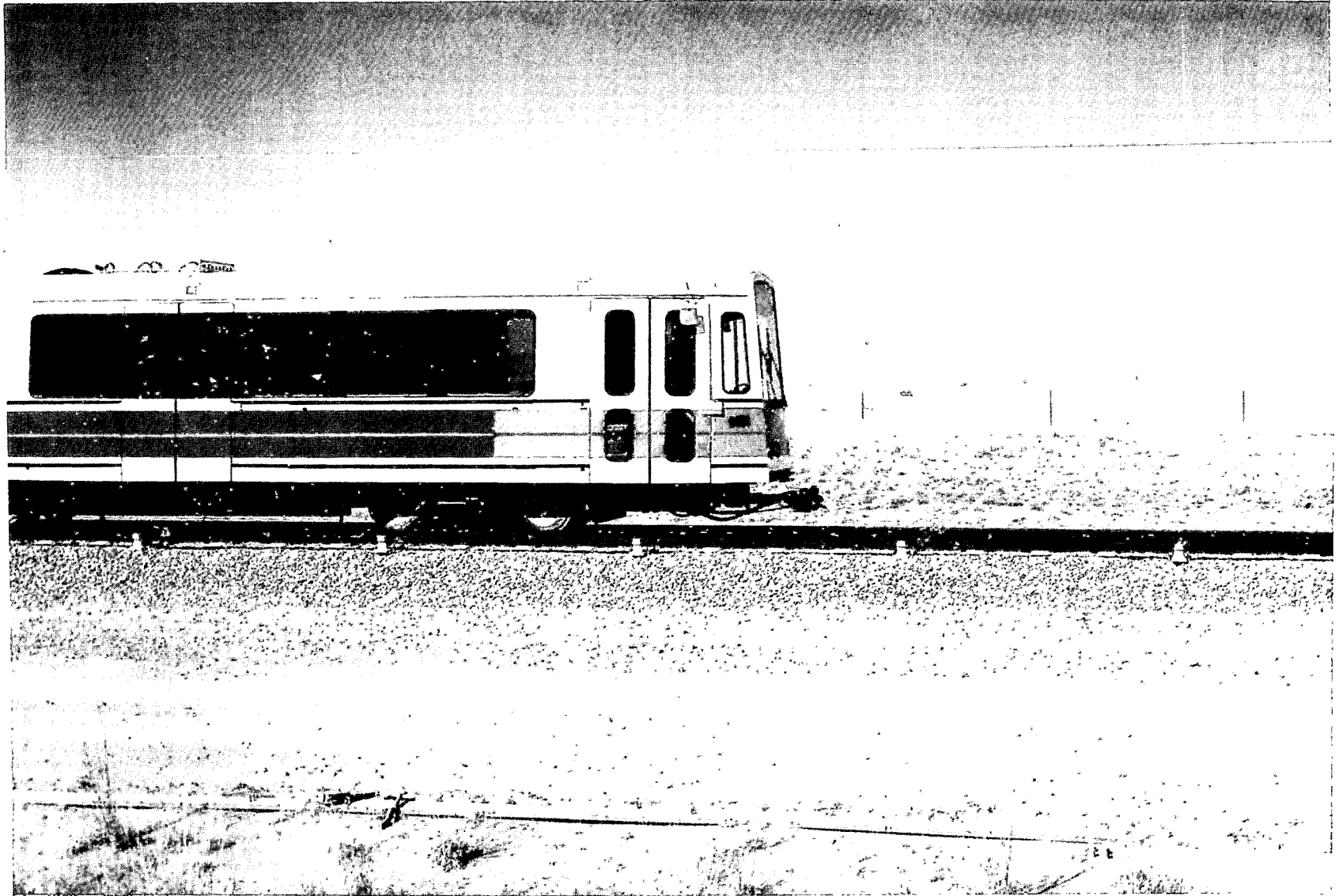

Figure 1-3. MBTA Car on Track

1-7



C25164

Figure 1-4. SFMR Car on Track

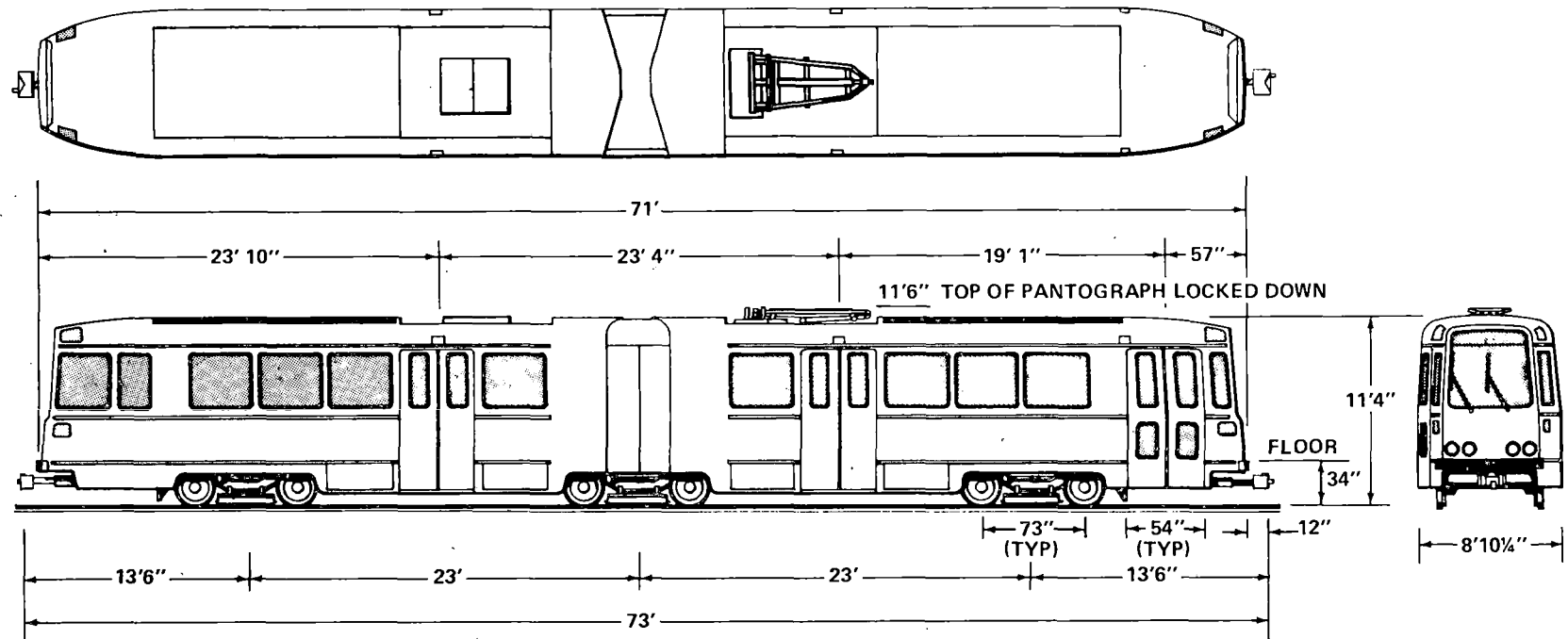

Length, over anticlimbers	71 ft	Acceleration, maximum	3.1 mph/sec
Height, from top of rail	11 ft 4 in.	Brake rate	
Width, maximum	8 ft 10 1/4 in.	Service, nominal	3.5 mph/sec
Weight empty	67,000 lb	Emergency, minimum	6.0 mph/sec (below 30 mph)
Passenger capacity			4.0 mph/sec (above 30 mph)
Seats — MBTA	52	Jerk rate, nominal	2.5 mph/sec/sec
Seats — San Francisco	68	Wheel diameter	26 in.
Maximum capacity	219	Power, nominal	600 volts D.C.
Track gauge	4 ft 8 1/2 in. (Std)	Noise levels	
Track radius, minimum, horiz	32 ft	Interior, all systems operating	65 dBa
Speed, maximum operating	50 mph*	Wayside 50 ft at 40 mph	80 dBa

*Higher speed capabilities are available

Figure 1-5. SLRV Design and Performance Characteristics

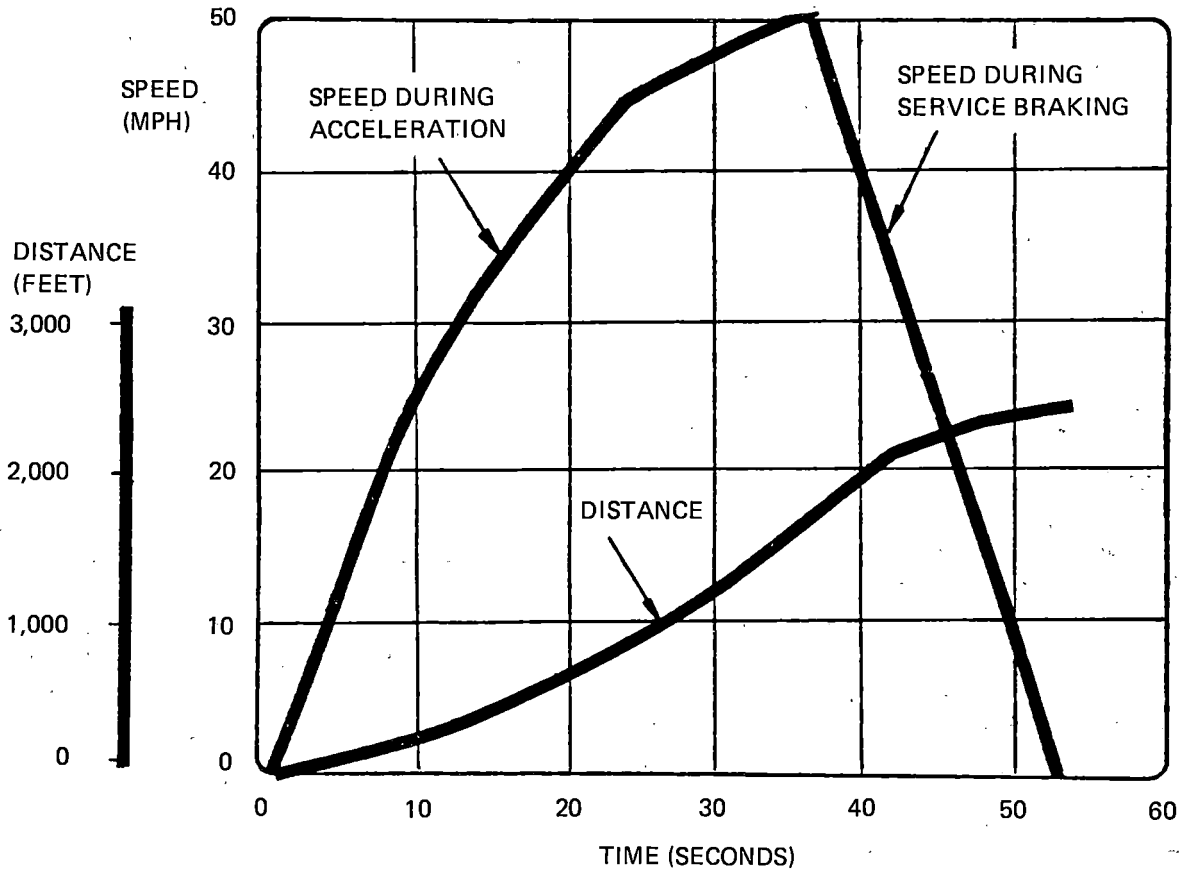

Figure 1-6. SLRV Operating Profile (Base LRV Plus 100 Passengers)

and emergency braking functions and load weight-compensation. Each friction brake caliper contains a spring actuator for emergency braking in the absence of hydraulic power.

Each vehicle is equipped also with six magnetic track brake assemblies operating from the low voltage power supply. On SFMR cars the track brakes can be controlled separately to avoid roll-back when starting vehicles on steep slopes.

Trucks and Suspension

Each vehicle is equipped with three, two-axle trucks: a non-motorized truck under the articulation section and two end trucks of a mono-motor configuration. The truck wheelbase is 6.5 feet (maximum) for standard gauge track. The truck design features all-welded steel construction; primary suspension is by means of elastomeric Chevron springs at each journal bearing and secondary suspension is provided by two air springs per truck. The air spring pressure is controlled by leveling valves which maintain the car floor at a constant height above the rail, thereby compensating for passenger loading.

The air pressure in the air springs is used as a feedback to the propulsion and braking control logic to provide a proportionate response in tractive effort and braking. It is adjusted for passenger load and braking effort on a per-truck basis.

Hydraulic shock absorbers of the rotary type are provided for lateral damping, and vertical damping is accomplished with secondary air spring orifice damping.

Wheels

All vehicles were operated throughout the test program with resilient, Acoustaflex wheels. These wheels are composite construction with aluminum hubs and steel rims and tires. There is a silicone rubber cushion pressure molded between the rim and hub sections with a multi-point shunt for electrical continuity. The wheels are 26 inches in diameter with a 1:40 tread contour on the MBTA cars and a 1:20 tread contour on the SFMR cars. The resilient wheels effect a significant reduction in wheel squeal when cars are negotiating low radius curves. In addition some reduction in wayside noise levels is achieved.

Test Vehicle Configuration

The three test cars (2 SFMR and 1 MBTA) were manufactured to the SLRV specification as modified by each operating authority, with no configuration deviations prior to shipment to Pueblo. The primary instrumented test cars were in the San Francisco configuration; i.e., SF0002 and SF0003. All performance and ride quality data obtained are applicable to both SFMR and MBTA vehicles. Where configuration differences dictated, tests were repeated on the MBTA car. During the program trainline operations were conducted with two SFMR cars, one SFMR with one MBTA car and two SFMR with one MBTA car.

Certain specific vehicle weight configurations are taken as standard references. They are:

- AW0 — Empty Operational Vehicle
- AW1 — Seated Load

- AW2 — Normal Load (100 Passengers)
- AW3 — Crush Loaded Vehicle (219 Passengers)

The AW0 weight, including 1,770 lb of instrumentation, was 69,130 lb. For AW2 and AW3 conditions the cars were ballasted to gross weights of 82,500 lb and 104,495 lb respectively.

An Inspection Log Book and a Test Configuration Log Book were maintained for each car, recording the maintenance work accomplished and configuration changes resulting from component removal, replacement and adjustment.

1.3 TEST SITE

The SLRV testing was conducted at the Department of Transportation, Transportation Test Center, Pueblo, Colorado, over a level section of the Rail Transit Test Track (RTTT).⁴

Car storage, maintenance repair and static testing were accomplished in the Transit Maintenance Building (TMB) at the TTC base. This building is capable of accommodating two SLRV cars on a single track and is equipped with an inspection pit and 600 VDC 200 amp power supply (see Figure 1-7).

Test Track

The RTTT is a 9.1 mile loop, approximately oval and incorporating six different track construction methods, as shown in the plan in Figure 1-8. A 2.0 mile section of this track from rail station 279 to rail station 385, including 4,000 feet of level tangent track, was used for SLRV test purposes. The RTTT profile is shown in Figure 1-9.

The 2.0 mile SLRV test track was provided with a simple overhead (catenary shaped) wire. The wire profile varied up to 2 feet in height per 100 foot run, with a stitch of ± 5 inches every 200 feet. Vertical profile and stitch are shown tabulated in Table 1-2. Power was supplied to the wire from the third (contact) rail by means of jumper wires located at each support pole, spaced 100 feet apart. The third rail was moved 6.25 inches to provide clearance for the SLRV carbody. Figure 1-10 shows the catenary shaped wire and support. Figure 1-11 is a view from the cab.

Power Sources

The primary power source for the SLRV testing was DOT 0001, a GE U30C diesel-electric locomotive rated at 3,400 amps. Alternator characteristics of the locomotive are shown in Figure 1-12. Auxiliary power was supplied by the "West Generator", a Caterpillar 500 kw DC diesel generating set. Nominal no-load voltage from DOT 0001 was set at 660 VDC, which reduced to 575 VDC under single car maximum acceleration load. For trainline operations, the West Generator was used with DOT 001 to prevent excessive line voltage drop.

-
4. Requirements for Design of Balance of UMTA Rail Transit Test Track, TSC, GSP-007, November 1971.

1-12



C25158

Figure 1-7. SLRV Test Cars in Transit Maintenance Building

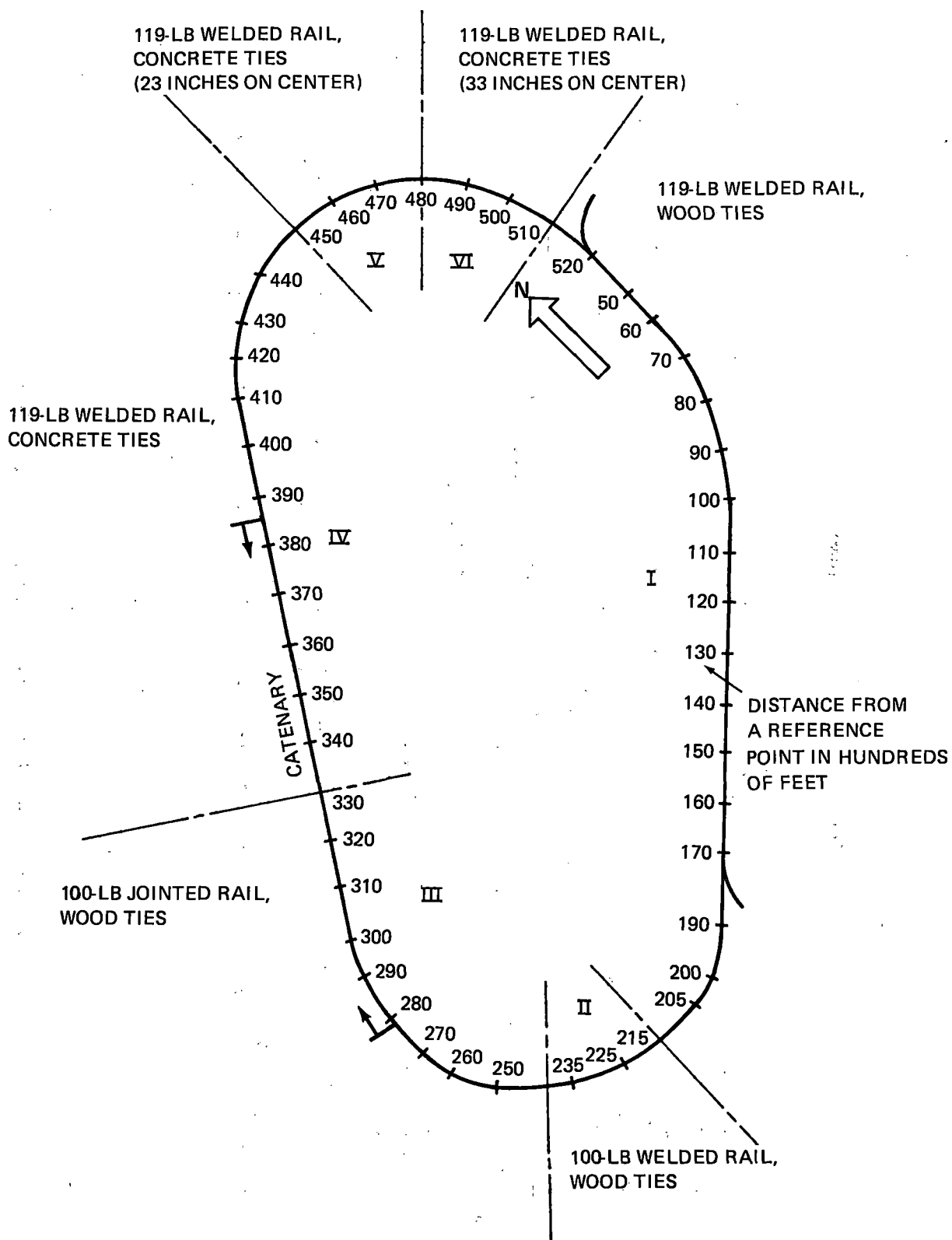

Figure 1-8. UMTA Rail Transit Test Track

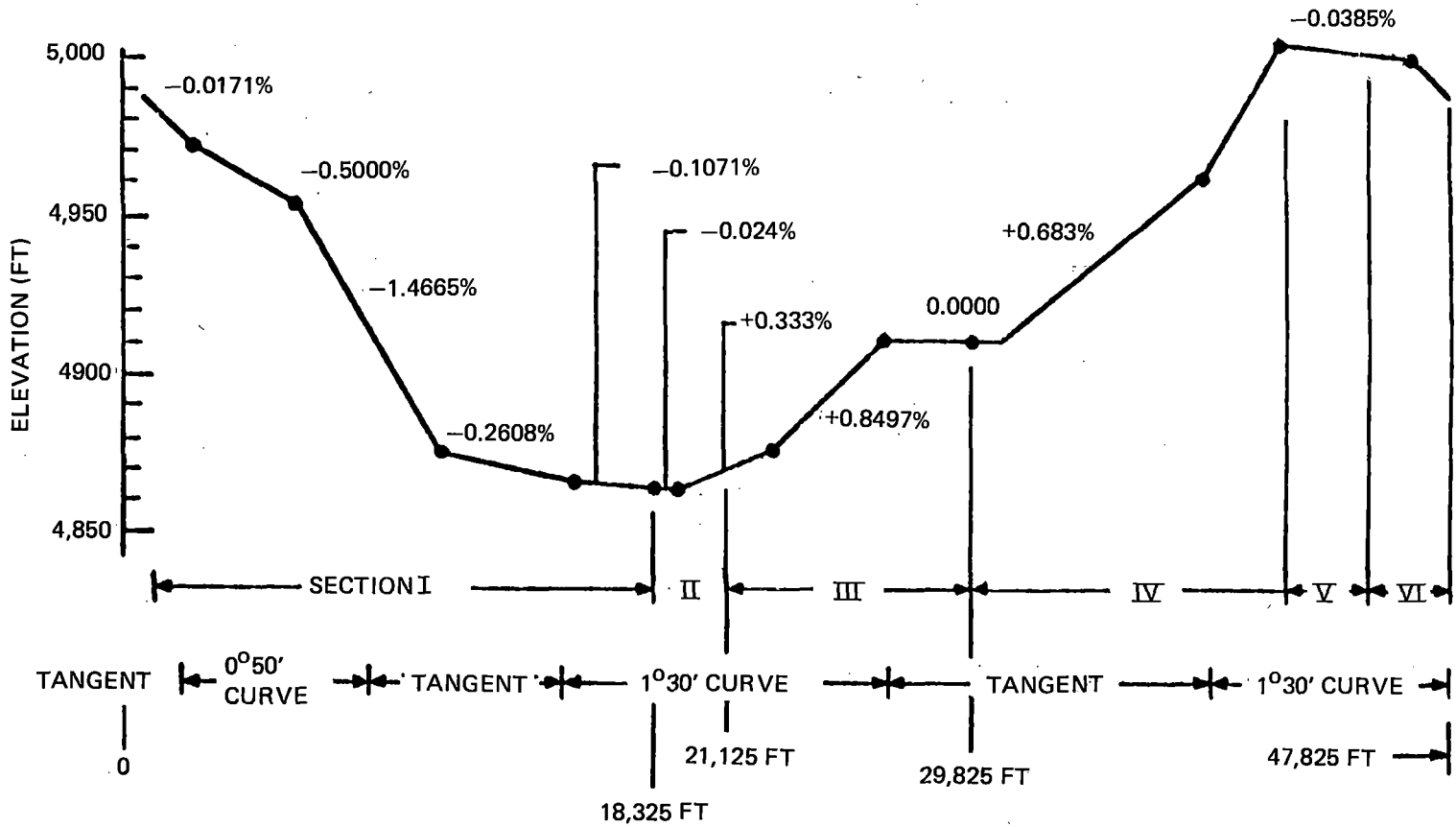

Figure 1-9. Rail Transit Test Track Profile Showing Grades

TABLE 1-2. RTTT CATENARY PROFILE FOR SLRV TESTING

Sta 100 Ft	Height Ft	Stitch In.	Sta 100 Ft	Height Ft	Stitch In.	Sta 100 Ft	Height Ft	Stitch In.
279	18.0	0	315	12.5	0	351	13.5	0
280	18.0	0	316	12.5	-5	352	14.0	-5
281	18.0	-5	317	13.0	0	353	14.0	0
282	16.0	0	318	13.5	+5	354	15.0	+5
283	16.0	+5	319	14.0	0	355	16.0	0
284	14.0	0	320	14.5	0	356	18.0	-5
285	14.0	0	321	15.0	0	357	18.0	0
286	12.5	-5	322	15.5	-5	358	19.0	+5
287	12.5	0	323	16.0	0	359	19.0	0
288	12.5	+5	324	16.5	+5	360	19.0	0
289	12.5	0	325	17.0	0	361		
290			326	17.5	-5	362	19.0	-5
291			327	18.0	0	363	19.0	0
292	12.5	-5	328	18.5	+5	364	19.0	+5
293	12.5	0	329	19.0	0	365	19.0	0
294	12.5	+5	330	19.0	0	366	19.0	-5
295	12.5	0	331	19.0	0	367	19.0	0
296	14.0	-5	332	19.0	-5	368	19.0	+5
297	16.0	0	333	18.5	0	369	19.0	0
298	18.0	+5	334	18.0	+5	370	18.0	-5
299	19.0	0	335	17.5	0	371	18.0	0
300			336	17.0	-5	372	18.0	+5
301	18.5	0	337	16.5	0	373	16.0	0
302	18.0	-5	338	16.0	+5	374	16.0	-5
303	17.5	0	339	15.5	0	375	16.0	0
304	17.0	+5	340	15.0	0	376	16.0	+5
305	16.5	0	341	14.5	0	377	16.0	0
306	16.0	-5	342	14.0	-5	378	16.0	-5
307	16.5	0	343	13.5	0	379	14.0	0
308	16.0	+5	344	13.0	+5	380		
309	14.5	0	345	12.5	0	381	16.0	0
310	14.0	0	346	12.5	-5	382		
311	13.5	0	347	12.5	0	383	18.0	0
312	13.0	-5	348	12.5	+5	384		
313	12.5	0	349	12.5	0	385		
314	12.5	+5	350	13.0	0			

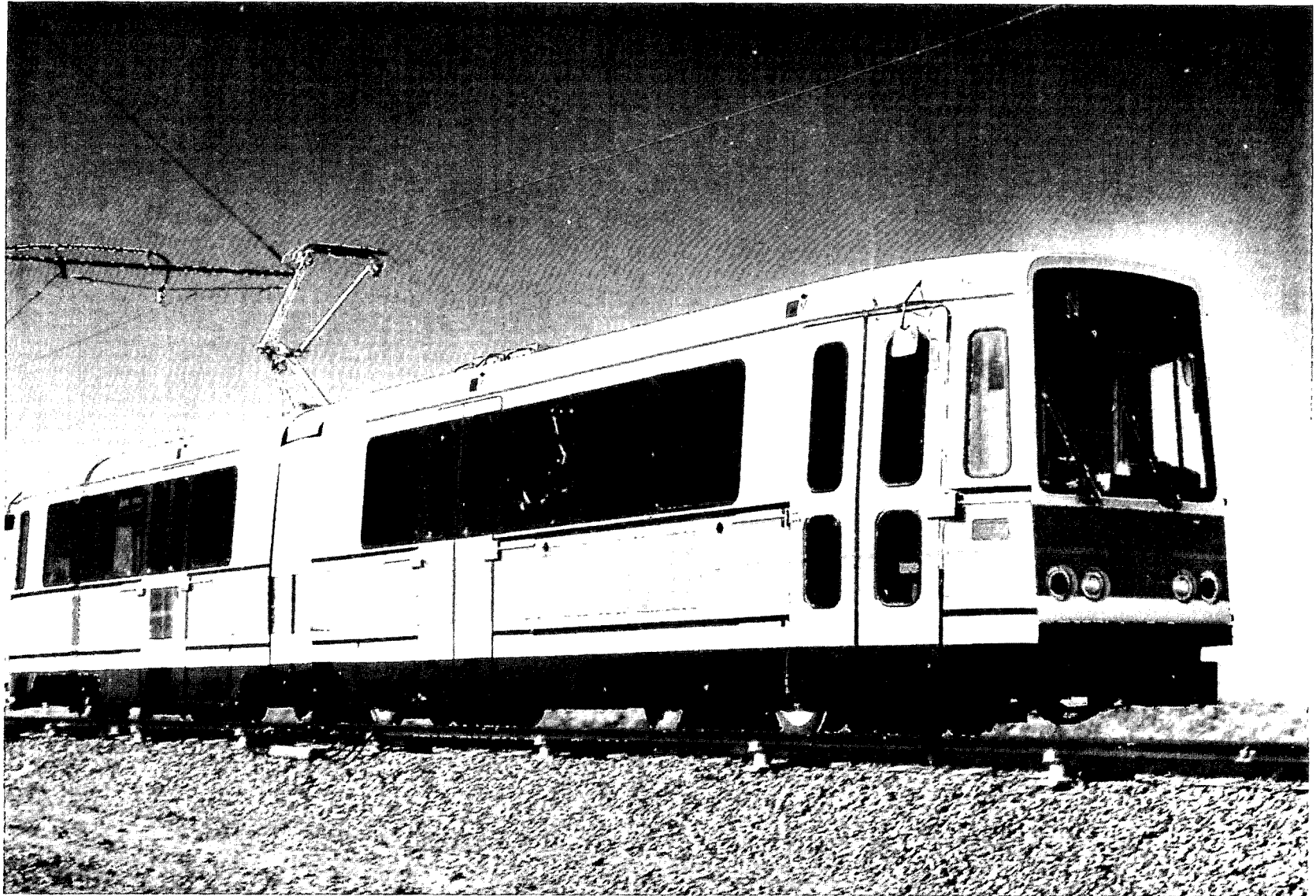

Figure 1-10. SLRV on Test Track Showing Catenary, Support, and Jumper Wiring

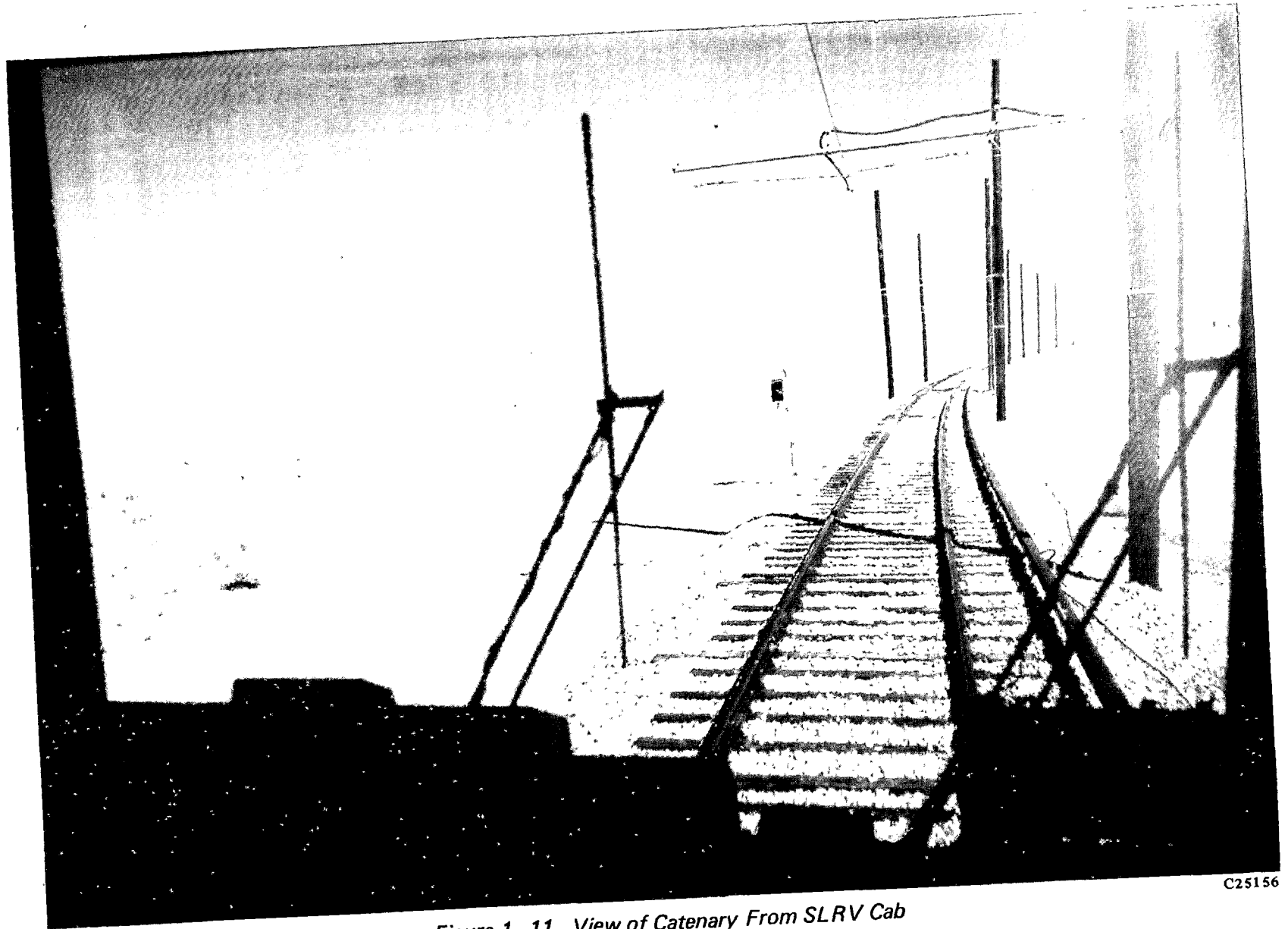

Figure 1-11. View of Catenary From SLRV Cab

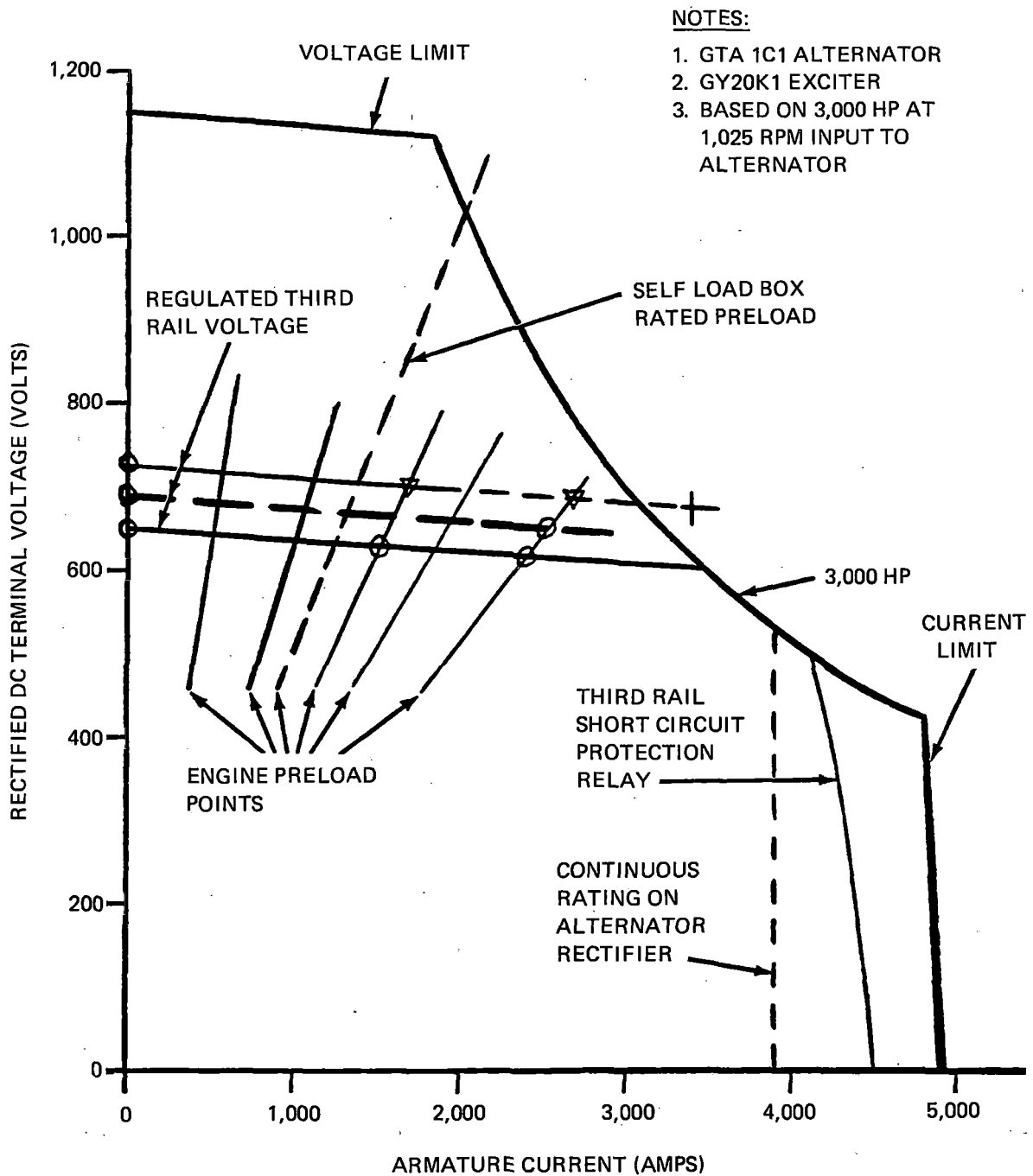

Figure 1-12. Alternator Characteristics of Locomotive Used for Power Source (DOT-001; GE U30C)

1.4 GENERAL VEHICLE TEST PLANS

The format used in the SLRV engineering tests was based on the DOT-TSC General Vehicle Test Plans (GSP-064), which are designed to provide the data necessary for the quantitative comparison of different transit cars, in the case of the SLRV for the Urban Rail Test and Evaluation Program. Characteristics evaluated during the tests include the following:

- Performance (Acceleration, Deceleration, Spin/Slide, etc.)
- Power Consumption
- Ride Quality
- Noise
- Radio Frequency Interference

Previous testing using GSP-064 Methodology (e.g., UMTA State-of-the-Art Car (SOAC)) was directed, at least in part, to the improvement of the General Vehicle Test Plan and was conducted on developmental vehicles. As a result of this testing an expanded and improved document was released in September 1975.⁵

The SLRV engineering test program is the first practical application of the GVTP to a production vehicle to generate data for purely comparative purposes.

General Vehicle Test Set

The basic unit of the GVTP is the test set. Each test set is related to one of the test categories and is identified by a unique number. Figure 1-13 shows a typical test set, number SLRV-P-2011-TT. The identifying number is generated as shown below:

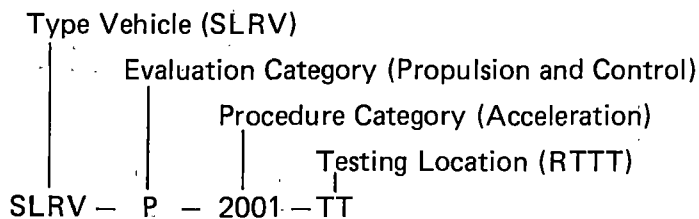

The test set includes a title, number, test description and procedure, instrumentation and data requirements.

Details of standard test sets (including code numbers), baseline test plans, standard outputs and preliminary analysis are included in Reference 5.

1.5 TEST OPERATIONS

The SLRV testing was conducted under the overall surveillance of a Technical Monitor furnished by the Transportation Systems Center. The testing was carried out by a team of Systems Test

5. General Vehicle Test Plan (GVTP) for Urban Rail Transit Cars, UMTA, MA-06-0025-75-14, September 1975.

PRELIMINARY ANALYSIS TEST SET NO. P-2011-TT		⑤	
Standard Output	Cross Plot or Summarize		
STANDARD OUTPUTS TEST SET NO. P-2011-TT			
Item	Standard Output	Output Format	
INSTRUMENTATION TEST SET NO. P-2011-TT			
Item	Sensor Location	Priority	Monitor
PROCEDURE TEST SET NO. P-2011-TT			②
<u>PRELIMINARY</u> (pre-test)			
1. Attach instrumentation or patch-in desired parameters at			
TEST SET	TEST TITLE: Acceleration	①	
	TEST SET NO.: P-2011-TT		
TEST OBJECTIVE: To determine the overall acceleration characteristics of the test vehicle as affected by controller input level, line voltage, car weight (load weighing), car direction and train consist.			
TEST DESCRIPTION: The test vehicle will be accelerated at the required controller command on level tangent track. The following combinations will be tested:			
<u>Prime Variable</u>		<u>Test Conditions</u>	
Controller Level		1/2 and Full Power	
Line Voltage		Minimum, Nominal and Maximum Voltage	
Car Weights		AW0; AW2; AW3	
Car Direction		Forward and Reverse	
Train Consists		Single Car & Four-Car Train	
STATUS:			

Figure 1-13. General Vehicle Test Set - Example

engineers from the Boeing Vertol Company, supported by additional Boeing Vertol design engineers, technical staff and/or instrumentation engineers as required for specific tasks. For each test an SLRV Test Cover Card and Data Card was prepared, defining the specific test, car configuration, crew, passengers and listing the test runs and resulting data (see Figure 1-14).

An engineering test log book was maintained by the test engineer, containing a record of all the test runs performed during the program.

Upon completion of testing, the data tapes and records were forwarded to Boeing-Vertol where data was reduced, analyzed and plotted in the GSP 064 format for inclusion in this final test report.

LRV DATA CARD

TEST NO. 18
 CAR NO. SF0002
 CAR WT. AW2

SHEET 1 OF
 DATE: 12.11.75

TEST RUN NO.	TEST RUN								REC. NO.
	MODE	HAF TRF	SPEED	Cont. Lev.	TIME 600'	TIME 50MPH	DIST.	DIRECT.	
1	SPEED CALIB.		30		32.9	SPEED REC. 31.08	1500'	N	1
2	1500'		30		33.1	20.90		S	2
3			40		24.8	41.23		N	3

LRV TEST COVER CARD

TEST NO.: 18
 CAR NO.: SF0002

DATE: 12.11.75
 TIME - START:
 STOP:

PURPOSE: SINGLE CAR PERFORMANCE.

CONFIGURATION: AW2

CHANGES SINCE LAST TEST: GARRETT FITTED. CURRENT SHUNT & OSCILLOGRAPH TO MONITOR ARMATURE CURRENT DURING ACCELERATIONS (VERIFICATION OF HALL SENSOR.

CREW:

TEST ENGR. K. SIMMONDS MOTORMAN M. DUW
 DATA CONTROLLER T. DEMOSTROLOS YARD MASTER N. MYERS
 ADDITIONAL PERSONNEL #

COMMENTS: HERBY
 COMFORT
 SANDERS
 LENTIS
 GITTEN

Figure 1-14. SLRV Test Cards

2. TEST DESCRIPTION

2.1 OBJECTIVES AND SUMMARY DESCRIPTION

The test program was divided into five categories, in accordance with the concept of the General Vehicle Test Plans, GSP-064. These five categories, or test areas, were Performance, Power Consumption, Ride Roughness, Noise and Radio Frequency Interference. A brief description of each test area is given below.

Performance

The SLRV was tested throughout its operating range to record data establishing the vehicle capability in normal and emergency conditions.

Power Consumption

The SLRV's efficiency was established by measuring power consumption when operating the vehicle in a simulated revenue service configuration and balasted to represent the AW2 load condition.

Ride Roughness

Sufficient car body vibration data were recorded to define worst car body motions during normal operations.

Noise

Internal and external (wayside) noise levels were established by recording data at passenger and wayside locations. The effect of equipment noise, car speed, accelerations and decelerations was investigated.

Radio Frequency Interference

Broadband electromagnetic emissions radiated from the SLRV were measured. Wayside emission data was obtained for comparison with the RFI allowable limits specified for the vehicle.

2.2 TEST SETS

Within each category of testing, the discrete tests required were identified by individual test sets. These test sets are described below and are summarized in Table 2-1.

Performance Test Sets

Acceleration – SLRV-P-2001-TT

To determine the overall acceleration characteristics of the SLRV as affected by controller input, line voltage, car weight, and train consist.

TABLE 2-1. SUMMARY OF SLRV ENGINEERING TESTS

Test Area	Test Name	Test Set No.	Main Parameters	
Performance	Acceleration	SLRV-P-2001-TT	Time, distance/speed stopping distance/ time vs speed/weight	
	Deceleration			
	Blended braking	SLRV-P-3001-TT		
	Service friction	SLRV-P-3002-TT		
		Dynamic braking	SLRV-P-3003-TT	Drift resistance vs speed/weight Effy at 10-50 mph
		Emergency braking	SLRV-P-3004-TT	
		Traction resistance (drift)	SLRV-P-4001-TT	
		Spin/slide control		
	Acceleration	SLRV-P-2011-TT		
	Deceleration	SLRV-P-3011-TT		
Power Consumption	Power consumption	SLRV-PC-5011-TT	Line volts/amps/time	
Ride Quality	Ride roughness — worst speed	SLRV-R-1101-TT	Vibration	
Noise	Wayside noise		Sound pressure	
	Equip. noise-wayside	SLRV-CN-0001-TT		
	Effect of car speed-wayside	SLRV-CN-1001-TT		
	Interior noise		Sound pressure	
	Effect of car speed	SLRV-PN-1001-TT		
	Interior noise survey	SLRV-PN-1301-TT		
Acceleration effect	SLRV-PN-2001-TT			
Deceleration effect	SLRV-PN-3001-TT			
Radio Frequency Interference	Radio frequency interference	SLRV-PSI-6001-TT	Field intensity	

Deceleration – Including Blended Braking, SLRV-P-3001-TT, Service Friction Braking, SLRV-P-3002-TT, Dynamic Braking, SLRV-P-3003-TT and Emergency Braking, SLRV-P-3004-TT

To determine the deceleration characteristics of the SLRV in four modes of braking as affected by car weight and train consist.

Drift Test (Traction Resistance) – SLRV-P-4001-TT

To determine the traction (train) resistance of the SLRV for use in the analysis of adhesion test data, to check the coefficients used to calculate the design performance of the vehicle and as a baseline for analysis of the vehicle tractive and braking effort values.

Friction Brake Duty Cycles – SLRV-P-5001-TT

To determine the thermal capacity of the SLRV friction braking system during sample service runs with the dynamic brake system inoperative.

Spin/Slide Control – Acceleration, SLRV-P-2011-TT and Deceleration, SLRV-P-3011-TT

To determine the efficiency of the SLRV spin/slide protective system during acceleration and deceleration for various rail conditions.

Power Consumption Test Set

Power Consumption – SLRV-PC-5011-TT

To determine the power consumption of the SLRV operating on a simulated service route (N-Line Duty Cycle).

Ride Quality Test Set

Ride Roughness – SLRV-R-1101-TT

To determine the most severe vibration levels within the operational speed range.

Noise Test Sets

Wayside Noise Levels - Including Equipment Noise SLRV-CN-0001-TT and Effect of Car Speed, SLRV-CN-1001-TT.

To determine the contribution of equipment noise to total SLRV noise and the noise levels during passbys at constant speed conditions.

Interior Noise Levels – Including Effect of Car Speed, SLRV-PN-1001-TT, Interior Noise Survey, SLRV-PN-1301-TT, Acceleration Effect, SLRV-PN-2001-TT and Deceleration Effect, SLRV-PN-3001-TT.

To determine the noise levels existing inside the SLRV at various locations, over a range of speeds, accelerations and decelerations.

Radio Frequency Interference Test Set

Radio Frequency Interference — SLRV-PSI-6001-TT

To determine the levels of broadband radiated electromagnetic emission from SLRV to wayside.

Coversheets of the Test Sets used for the SLRV test program, showing the test status, form Appendix A to this report.

2.3 INSTRUMENTATION

The prime data acquisition system for the SLRV test program was built up utilizing a combination of Boeing Vertol equipment and TTC equipment and was installed in test vehicle SF 0002. The signal conditioning and recording equipment was located between the center doors of the "B" section of the car. A view of this installation is shown in Figure 2-1. Power was provided by a 5 kw portable diesel operator set carried between doors of the "A" section of the car with the exhaust vented between the doors. The codes for the parameters recorded are shown in the Instrumentation Legend, Table 2-2 and a block diagram of the overall system is shown in Figure 2-2, while Table 2-3 lists the individual items of equipment by type and serial number.

The system was capable of recording dynamic data simultaneously on three CEC oscillographs and/or two magnetic tape recorders. An IRIG time code generator was used to correlate the records.

Performance Tests

Performance test instrumentation is listed in Table 2-4. The first sixteen parameters are signals taken from the vehicle feedback control system and from diagnostic connectors in the Garrett Electronic Control Unit (ECU). To isolate the ECU from any influence by the instrumentation system the sensors were connected through high impedance Burr Brown Buffer amplifiers.

Ride Quality Tests

Ride quality instrumentation is listed in Table 2-5, including accelerometer locations.

Noise Tests

Noise data was hand recorded, using a B&K Noise Meter, Type 2203, S/N 359555 with attached windscreen and two Nagra recorders, Type III, S/N 10290 and Type IV, S/N 1353. Calibrator was Type 4230, S/N 378273. All readings were A-weighted, slow.

Radio Frequency Interference Tests

A survey was made of radiations in the car interior, on the outside surface, and at wayside distances of 50 feet and 100 feet. Instrumentation used is shown in Table 2-6.

Sampling ranges of the antennas are shown in Table 2-7.

Records were taken photographically using a Polaroid camera and attachment to the Spectrum Analyzer.

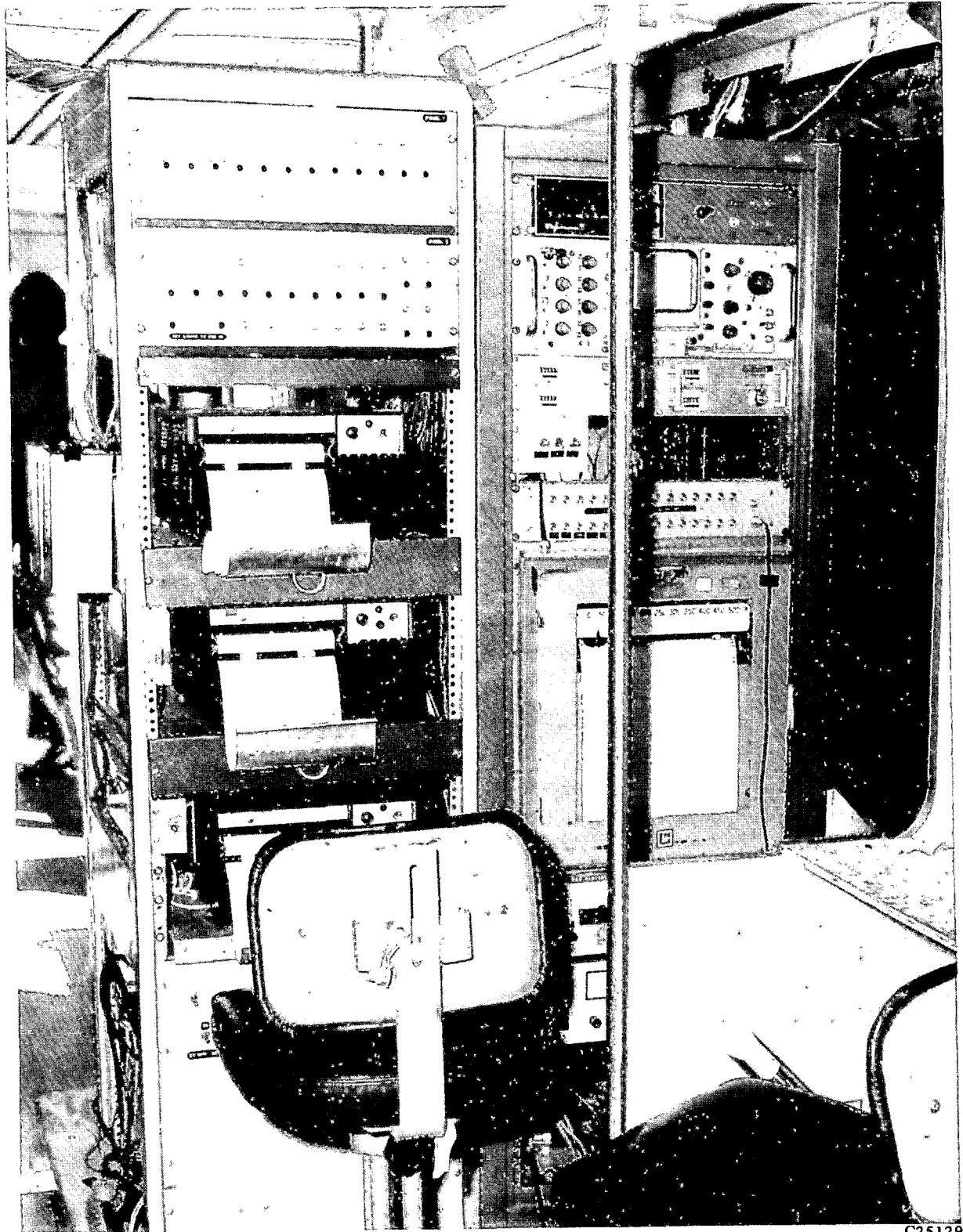

C25129

Figure 2-1. Instrumentation Installation on SF-0002

TABLE 2-2. SLRV INSTRUMENTATION LEGEND

Number	Code and Parameter
1.	LVD – DC Line Voltage
2.	MAVD – Motor Armature Voltage
3.	MACD – Motor Armature Current
4.	MFCD – Motor Field Current
5.	VS-1 – No. 1 Truck Speed
6.	VS-2 – No. 2 Truck Speed
7.	VS-3 – No. 3 Truck Speed
8.	VS-4 – No. 4 Truck Speed
9.	C/S-A – Master Controller Position
10.	DBFB – Dynamic Brake Feedback
11.	FBCS-A – Friction Brake – Total Brake Command
12.	FBCS-B – Friction Brake – Blended Brake Comman
13.	Diagnostic – Uncommitted Test Point
14.	ET-1 – Slip-Slide Signal A Truck
15.	ET-2 – Slip-Slide Signal Center Truck
16.	ET-3 – Slip-Slide Signal B Truck
17.	1 ₁ – Line Current – AAC Sensor 1000 Amp
18.	1 ₂ – Line Current – AAC Sensor 750 Amp
19.	AP/A – Longitudinal Accel Range ± 1 g, CRD Model SA-100
20.	BCP-1 – Brake Pressure A Truck – Dynisco
21.	BCP-2 – Brake Pressure Center Truck – Dynisco
22.	BCP-3 – Brake Pressure B Truck – Dynisco
23.	Temp – Type J Thermocouples – Various Locations
<p>Note: Items 1 through 16 taken from Garrett Diagnostic Connectors</p>	

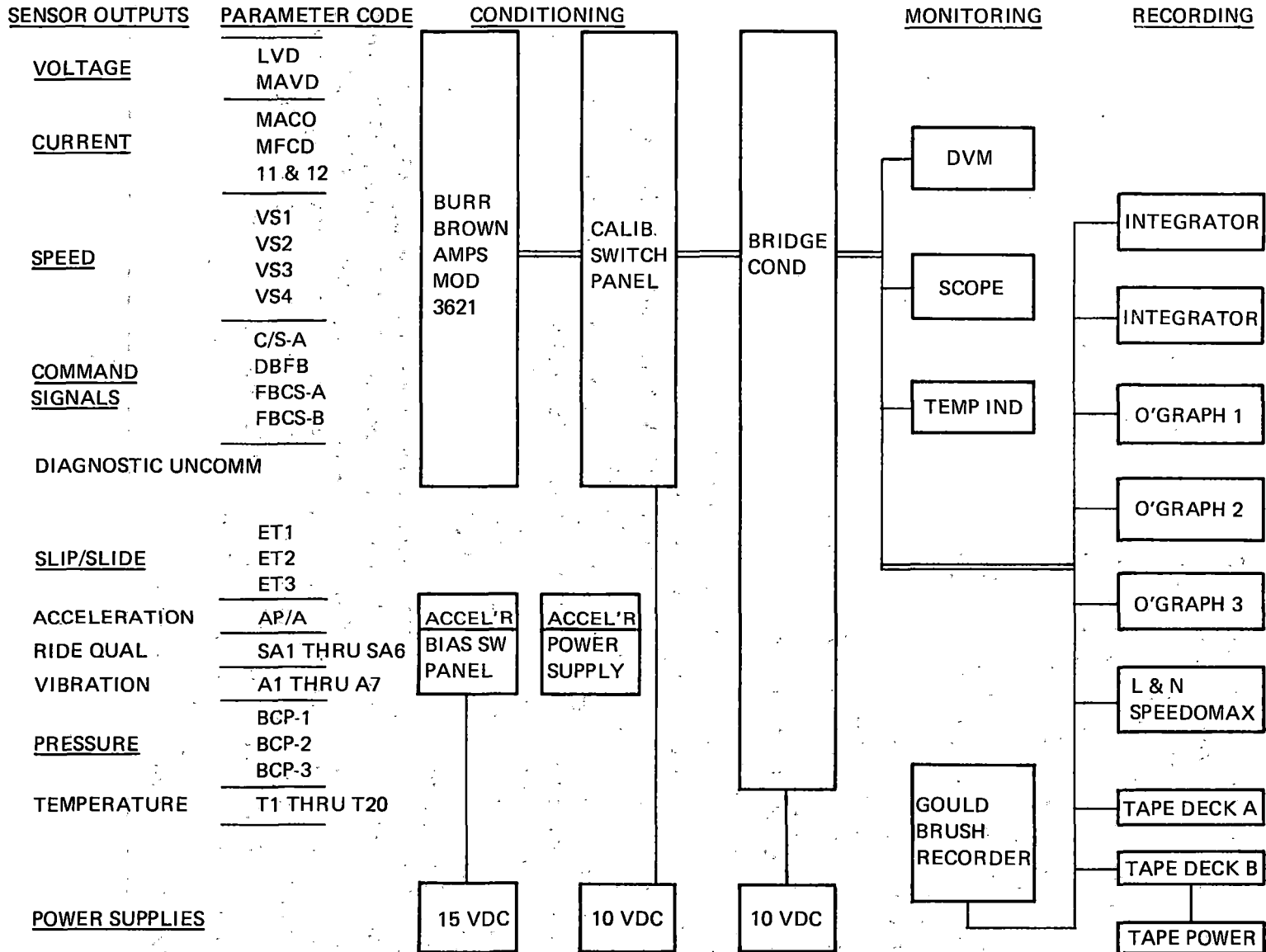

Figure 2-2. Instrumentation Block Diagram

TABLE 2-3. DATA CONDITIONING AND ACQUISITION EQUIPMENT

Burr Brown Amplifier Rack BCC 25775
 Burr Brown Amplifier Rack BCC 25776
 Calibration Switch Panels 1, 2, 3
 L&N Speedomax Temp Recorder B-65-37601-1-5 Seq 338400
 CEC Oscillograph (1) S/N 7322 BAC 317704
 CEC Oscillograph (2) S/N 2202 BCC 24275
 CEC Oscillograph (3) S/N 2096, Seq 263175
 CEC Oscillograph (4) S/N 2190
 Nova Inverter
 Data Precision DVM S/N 001, Mod SM-1
 Tektronix Oscilloscope R564B, S/N 08964
 Integrator (1) S/N 037
 Integrator (2) S/N 038
 Lewis Temperature Indicator
 (2) Accelerometer Power Supply Acopian B32G730
 (2) Trygon Power Supply S/N 11442
 Power Supply H-P 6112A, S/N 12560
 Power Supply H-P 721A, S/N 0831
 Statham Accelerometers CA-10-600, S/N 510, 493
 Statham Accelerometer C-10-500-A3, S/N 2348
 Statham Accelerometers A5-5-350, S/N 14103, 14104, 14105, 14128, 14130, 14244
 Columbia Accelerometers SA-100, S/N 1507, 1508
 Gulton Accelerometers LA010265, S/N 106A, 109A, 166A, 103A, 167A, 115A, 171A
 Dynisco Pressure Transducers S/N 41187, 41182, 41185, 41184
 Current Sensor AAC 750 Amp, Seq 351130
 Current Sensor AAC 1500 Amp, Seq 351132
 Current Sensor AAC 1000 Amp, Seq 351131
 Ammeters Seq 025699, 025700
 Ithaco Filters 14681, 14682, 14683, 14684, 14685, 14686, 14687, 14688, 14689, 14690,
 14692, 14693, 14694, 14695, 14696, 14697, 14699, 14700, 14701, 14702, 14703, 14704
 Endevco Signal Conditioners CC08 (LVD), CA04 (MACD), CF02 (VS1), CF07 (I1), CF09 (I2),
 CF05 (VS1), CC14 (V52), CF03 (VS3), CC10 (VS4), CC01 (CS/A), CC11 (DBFB), CF06
 (FBCS-A), CA13 (FBCS-B), CA09 (UNCOM), CE85 (ET-1), CC61 (ET-2), CC63 (ET-3),
 CA05 (AP/A), CF20 (BCP-1), CG03 (BCP-2), CC56 (BCP-3), CF10 (EVENT)
 Honeywell Tape Recorders 5600, S/N 10719
 Gould Brush Recorder S/N 10866
 Hilger & Watts Inclinator Seq 125104

TABLE 2-4. PERFORMANCE TEST INSTRUMENTATION

Parameter	Burr Brown Channel	Oscill Channel	Galvo S/N	Endevco Cond Chan	Ithaco Filter Chan	Tape Track
Time code		1-2, 2-6	8333			A-1
Flutter comp		3-4	10765			B-1
			92731			A-2
						B-2
VS-1	1	2-2	4652	0	1	A-3
VS-2	2	2-3	2951	1	2	A-3
VS-3	3	2-4	4656	2	3	A-4
VS-4	4	2-5	4045	3	4	B-4
C/S	5	3-15	27276	4	5	A-5
		1-12, 2-11	402CY			B-5
			260DA			
LVD	6	2-12	7563	5	6	A-7
MACD	7	2-13	16214	6	7	A-13
MFCD	8	2-14	5641	7	8	A-9
DBFB	9	1-4	18348	8	9	B-10
FBCS-A	10	1-5	17627	9	10	B-8
FBCS-B	11	1-6	10349	10	11	B-12
ET-1	12	1-9	943CX	13	14	B-7
ET-2	13	1-10	883CX	14	15	B-11
ET-3	14	1-11	27272	15	16	B-9
I-1	15	1-14	19396	16	17	A-10
I-2	16	1-15	356CD	17	18	A-14
AP/A		3-9	2869	18	19	A-6
						B-6
BCP-1		2-7	27263	19	20	A-12
BCP-2		2-9	20922	20	21	B-14
BCP-3		2-10	778CX	21	22	A-8
Event		1-17	11567	22	23	B-13
		2-17	10064			A-11
		3-18	265BT			

TABLE 2-5. RIDE QUALITY INSTRUMENTATION

Parameter	Burr Brown Channel	Oscill Channel	Galvo S/N	Endevco Cond Chan	Ithaco Filter Chan	Tape Track
Time code		2-6, 3-14	10765			A-1
Flutter comp			9273			B-1
						A-2
						A-2
VS-2	2	2-3	2951	1	2	A-4
VS-3	3	2-4	4656	2	3	B-3
C/S-A	5	2-11, 3-15	402CY	4	5	A-5
			260DA			B-5
LVD	6	2-12	7563	5	6	A-7
MACD	7	2-13	16214	6	7	A-13
MFCD	8	2-14	5641	7	8	A-9
Event						
		2-17	10064			A-11
		3-18	265BT	22	23	B-13
SA1 Carbody, Vert, Over B Truck		3-8	1850	0	1	A-3
SA2 Carbody, Lat, Over B Truck		3-9	2869	18	19	A-6
SA3 Carbody, Long., Over B Truck		3-10	4458	21	22	A-8
SA4 Carbody, Vert, Over Center Truck	FLOOR Q	3-11	5417	16	17	A-10
SA5 Carbody, Lat, Over Center Truck		3-12	5448	19	20	A-12
SA6 Carbody, Long., Over Center Truck		3-13	1044	17	18	A-14
A-1 B Truck Transom Vert		3-2	21779	3	4	B-4
A-2 B Truck Transom Lat		3-3	8965	13	14	B-7
A-3 Cent. Truck Ped Vert		3-4	16005	9	10	B-8
A-4 Cent. Truck Bel Brg Vert		3-5	984CX	8	9	B-10
A-5 B Truck Ped Vert		3-6	134CO	14	15	B-11
Tests 54-56, Runs 53, 54, and 55 were Motor Vertical and Lateral						

2-10

TABLE 2-6. INSTRUMENTATION FOR RFI TESTS

Hewlett-Packard Spectrum Analyzer 141T with Polaroid Attachment
Hewlett-Packard Analyzer RF Section 8553B
Hewlett-Packard Analyzer IF Section 8552B
Hewlett-Packard Analyzer RF Section 8854L
Hewlett-Packard Analyzer LF Section 8556A
Nova Inverter 5060-12 S/N 864-10
Conical Log Spiral Antenna Model 3101 S/N 2613
ENCO Biconical Antenna Model 3104
Empire Devices VR 105 Antenna (2)

TABLE 2-7. ANTENNA RANGES

VR 105	14 kHz	15 kHz
VA 105	150 kHz	360 kHz
	360 kHz	870 kHz
	870 kHz	2.1 MHz
	2.1 MHz	5.2 MHz
	5.2 MHz	12.7 MHz
	12.7 MHz	30.0 MHz
Biconical 3104	20.0 MHz	200.0 MHz
Conical Log Spiral 3101	200.0 MHz	1.0 GHz

3. TEST RESULTS

3.1 SUMMARY

The major objective of the SLRV Engineering Test Program was to obtain baseline engineering data on the Light Rail Vehicles for quantitative comparison purposes in the Urban Rail Test and Evaluation Program.¹ Some of the data utilized in this report was recorded in conjunction with the SLRV Qualification Test Program, and reported in Reference 6.

3.2 RESULTS

Volumes II and III of this report contain detailed descriptions and discussions of the engineering tests performed on samples of the Standard Light Rail Vehicle at the Transportation Test Center at Pueblo, Colorado. A summary of each of the categories of tests is presented in the following paragraphs of this section.

3.2.1 Performance Tests

The SLRV test cars were tested through the design operating range of weight, line voltage, controller level and brake subsystem as well as in sample service tests to define power consumption. Adhesion levels and performance of spin/slide control systems were also tested. Summaries of the performance testing follow.

Acceleration and Blended Braking Control Characteristics

Figures 3-1 through 3-3 show a synopsis of the acceleration performance of the SLRV as a function of line voltage, car weight and control setting. Full details of these characteristics together with the deceleration characteristics are included in Vol. II of this report.

Figure 3-4 illustrates the results of control linearity tests for acceleration and blended braking at car weights of 69,130 lb (AW0) through 100,945 lb (AW3).

Traction Resistance

Drift tests were performed to determine the traction resistance (force versus speed) characteristic for use in the analysis of wheel-rail adhesion test data and to develop the traction forces associated with measured acceleration and deceleration rates.

Figure 3-5 presents the final faired curves of single car and two-car test data. The single car data is the primary requirement for adhesion and performance data analysis. The 920 pounds of resistance at 50 mph represents a coasting deceleration rate of 0.24 mphps for the 82,500-pound car.

6. Final Test Report for the Standard Light Rail Vehicle (SLRV), Boeing Vertol Company, D334-10098-1.

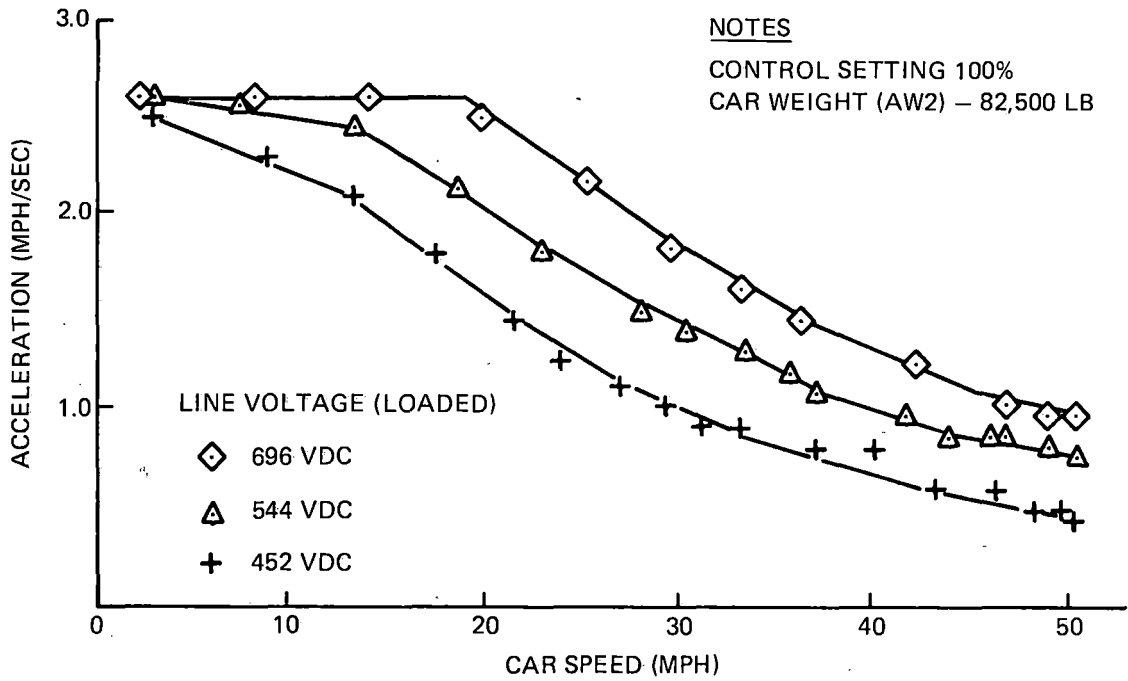

Figure 3-1. Effect of Line Voltage on Acceleration

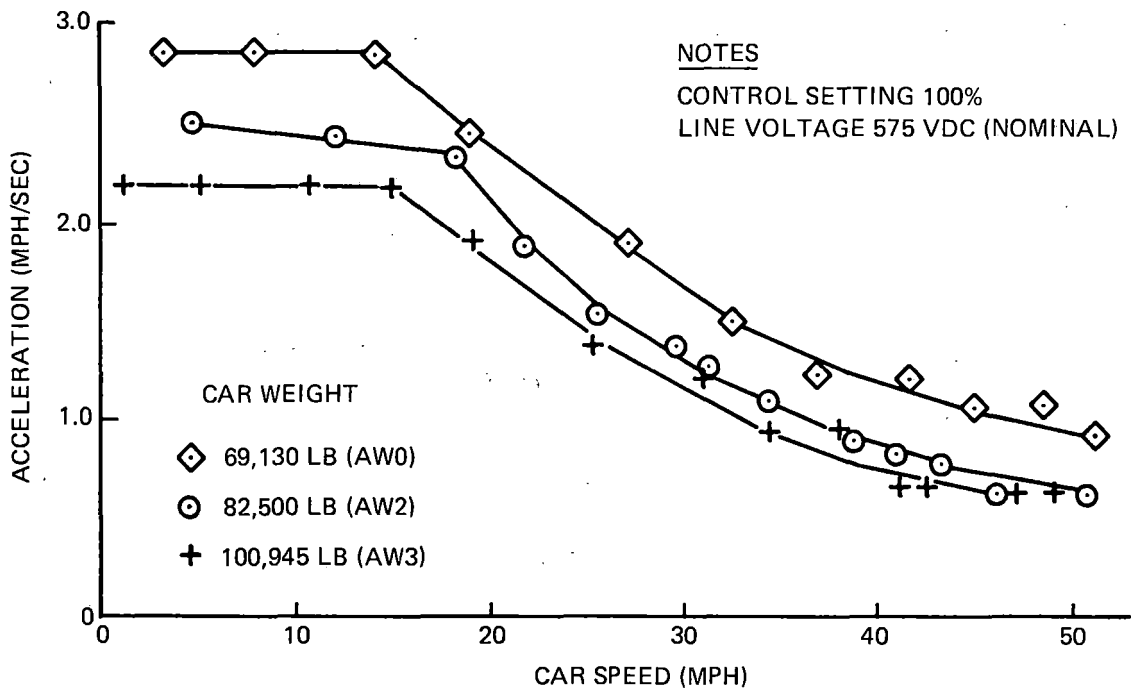
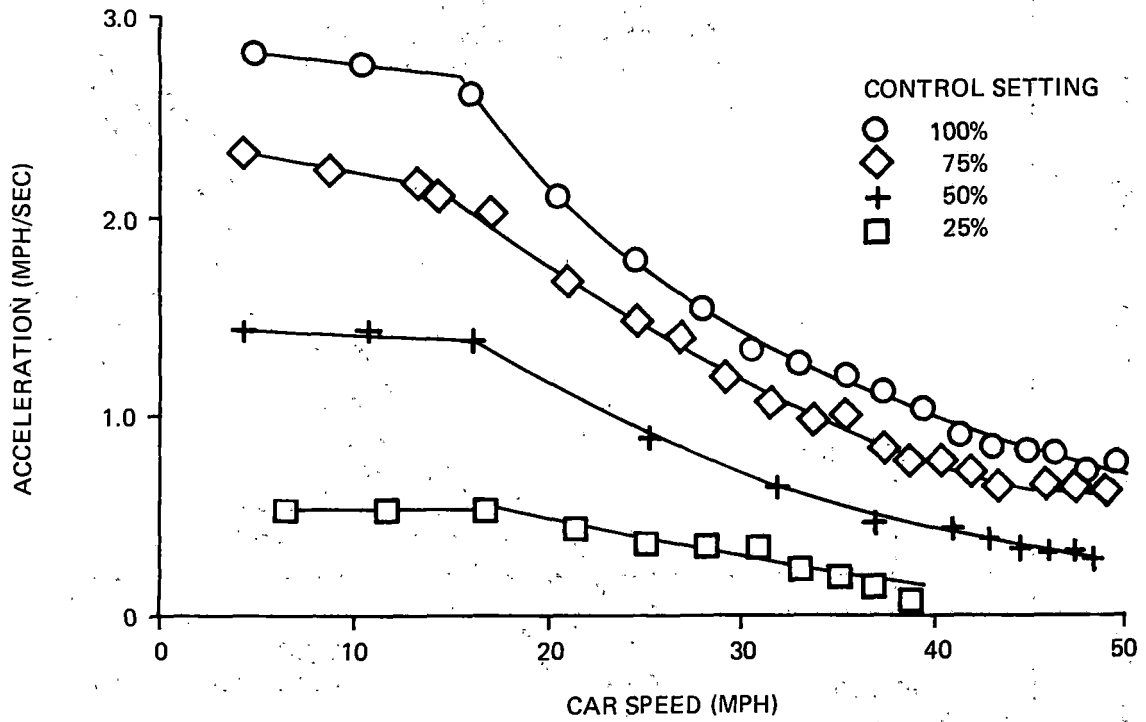

Figure 3-2. Effect of Car Weight on Acceleration



NOTES

CAR WEIGHT 82,500 LB (AW2)
 LINE VOLTAGE 575 VDC (NOMINAL)

Figure 3-3. Effect of Control Setting on Acceleration

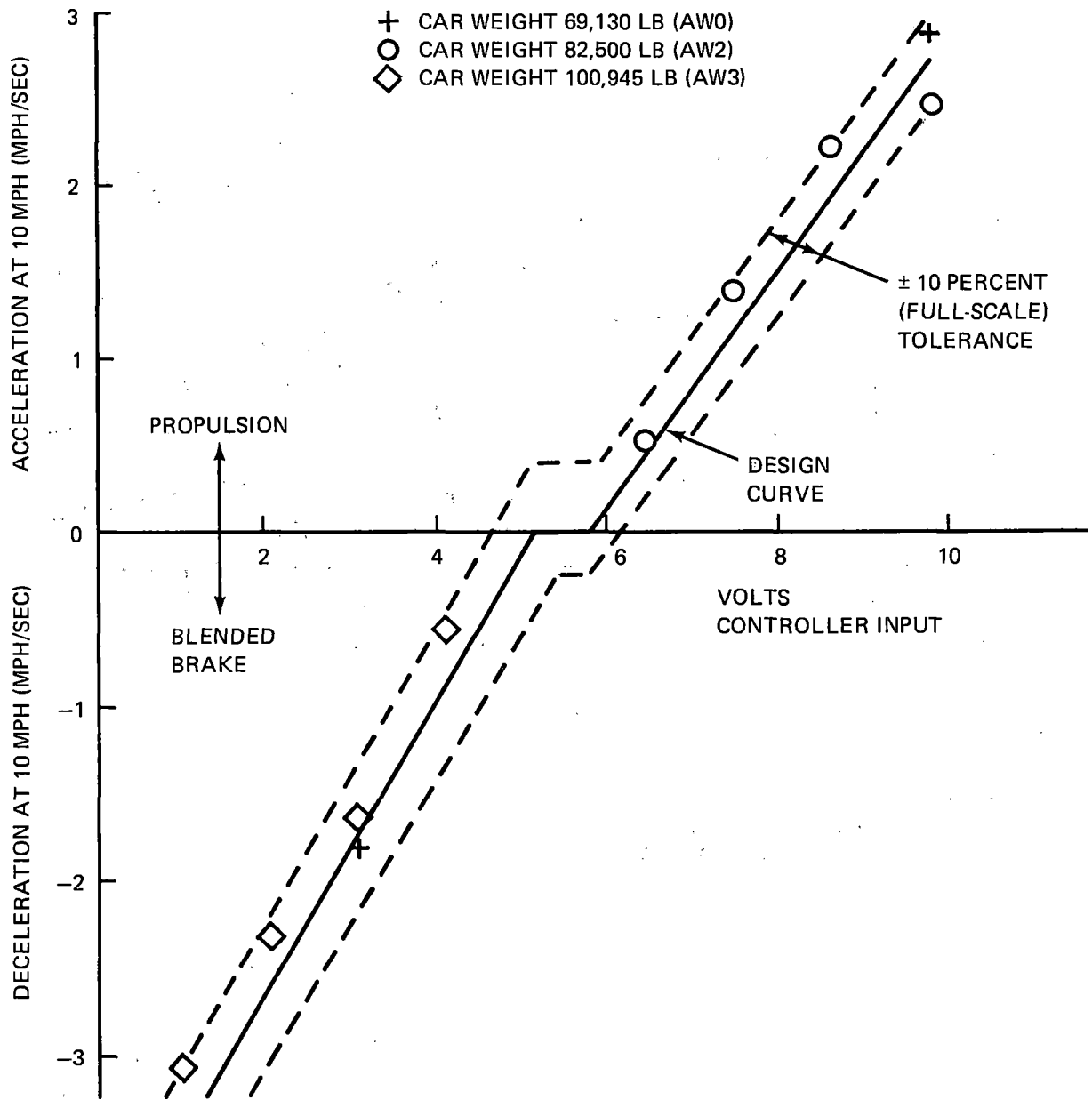

Figure 3-4. Control Linearity

NOTES

1. CAR WEIGHT 82,500 LB
2. AVERAGE OF BIDIRECTIONAL RUNS
3. LEVEL TANGENT TRACK
4. ZERO WIND
5. INCLUDES GEARBOX, MOTOR BRUSH FRICTION AND WINDAGE

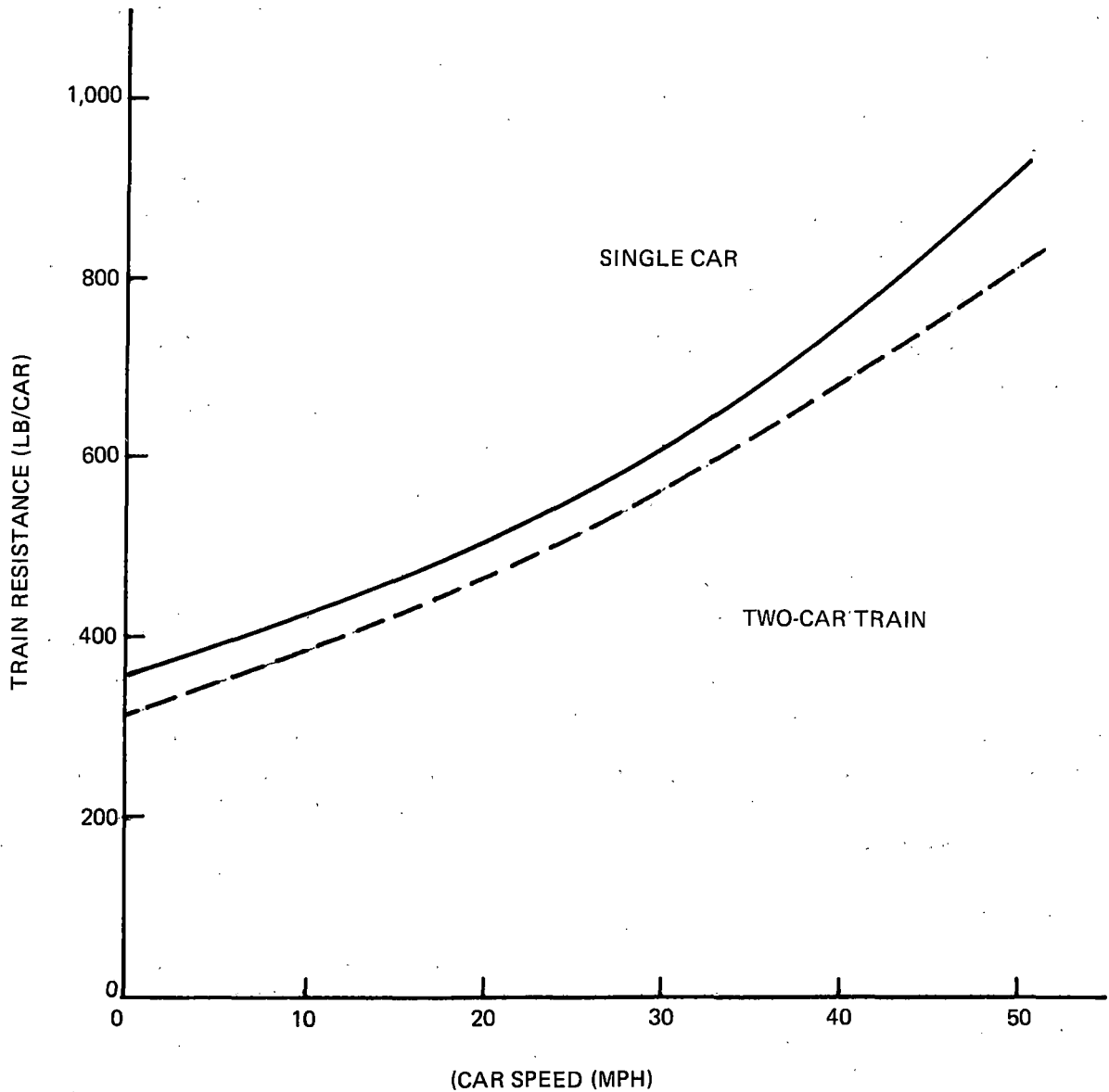

Figure 3-5. Traction Resistance

Spin-Slide Protection System Performance

Tests of spin/slide system characteristics were conducted in drive and brake modes on dry and wetted rail using full power acceleration and full service blended and friction only braking.

Several tests were conducted using partial blended braking modes (75, 50, and 25 percent of full service blended braking), but wheel slides did not occur. Similarly, due to the difficulties encountered in generating wheel spins at full acceleration, testing at partial acceleration condition was not conducted.

Table 3-1 summarizes the minimum efficiencies of the spin/slide systems identified during braking in the different modes in test runs initiated at speeds from 50 to 20 mph. In the acceleration mode although testing was conducted up to 45 mph, wheel spin did not occur much beyond base speed.

TABLE 3-1. SUMMARY OF WHEEL SPIN/SLIDE SYSTEM EFFICIENCIES (69,230 LB CAR)

Braking Mode (Speed Range 50 to 20 mph)	—	Goal 75%
Blended Braking	76.3%	
Service Friction Braking	78.0%	
Accelerating Mode (Speed Range 0 to 45 mph)	—	Goal 40%
Full Power Acceleration	45.9%	

$$\text{Efficiency} = \frac{\text{Actual Rate}}{\text{Max Average Rate for the Available Adhesion}}$$

3.2.2 Power Consumption

Schedule service performance in terms of power consumption, schedule speed and undercar temperatures were evaluated during sample service runs on a 14.49-mile, 93-station transit route simulating an N line duty cycle. The route simulates combined surface/subway route operation with maximum speeds of 26 mph surface and 50 mph subway. Running was done on the 2-mile section of the rail transit test track equipped with overhead power, namely from station 279 to station 385 alternating northbound and southbound operation. Energy consumption data obtained from the tests indicate an almost linear relationship between consumption rate and line voltage as seen in Figure 3-6.

3.2.3 Ride Roughness Tests

The ride quality vibration data were recorded on analog tapes and later digitized to obtain spectrum analysis and ride roughness numbers. The purpose of this series of tests was to provide an understanding of the car body motions during operations. Narrow band spectrum analysis permits identification of vibration contributions from known modal characteristics of the car body structure. The spectrum analysis curves for the end car centerline vertical locations are shown in Figure 3-7. Results of the SLRV testing show that for the TTC test track

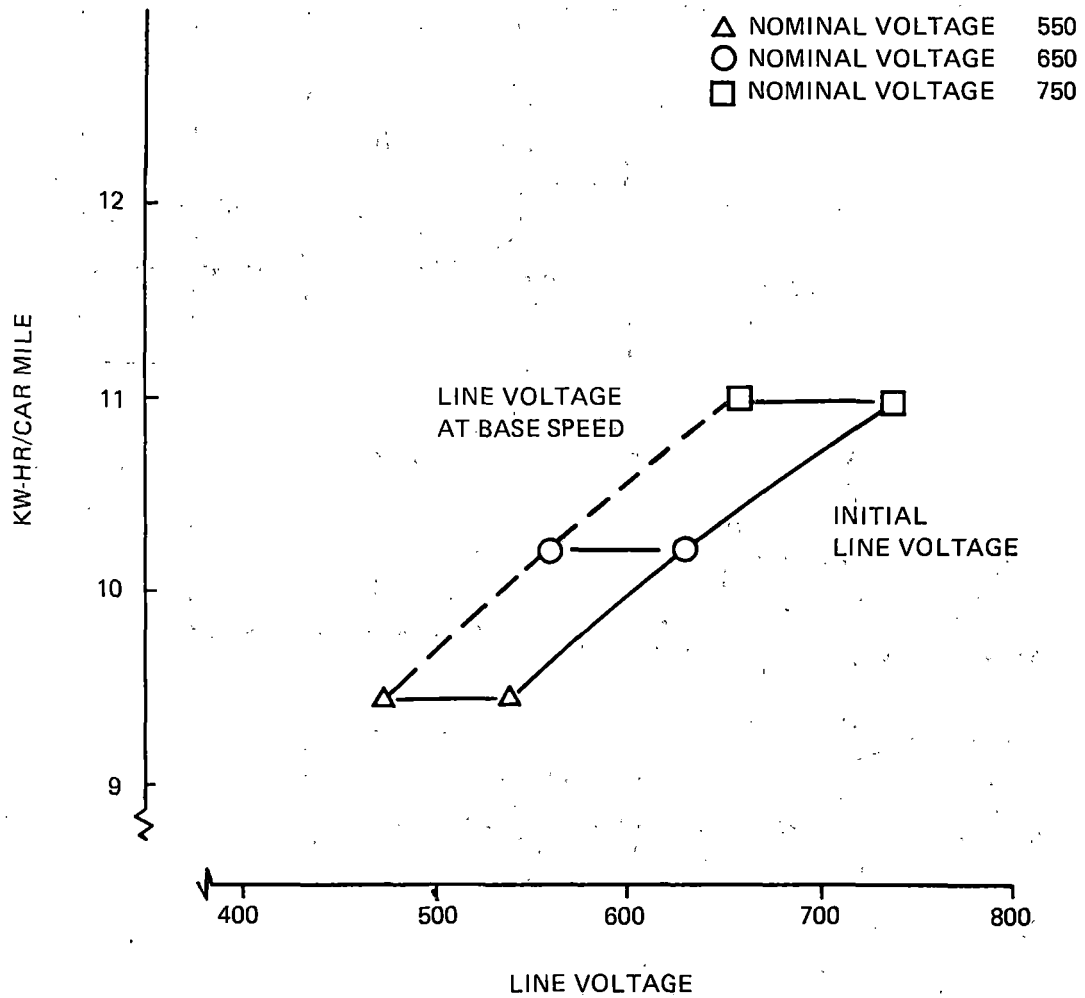

Figure 3-6. Power Consumption on Simulated N Line Operation (93 Station Stops, 14.49 Miles)

NOTES

CAR WEIGHT, AW3 (100,945 LB)
END CAR VERTICAL ACCELERATIONS

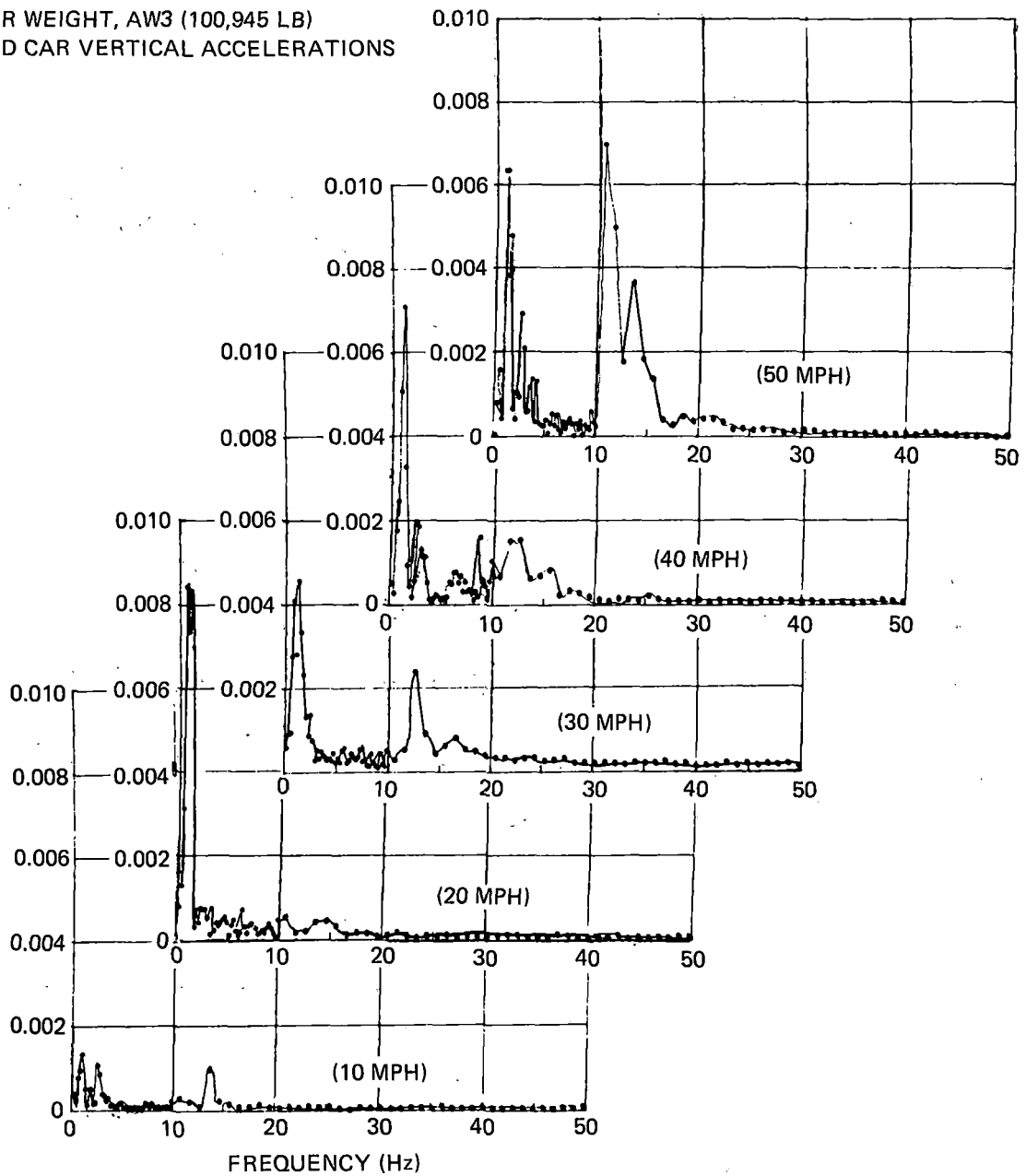

Figure 3-7. Ride Quality Baseline Comparison: Effect of Speed

the vibration levels provide acceleration indicators for evaluating the effect of speed, weight, and other variables on passenger ride quality.

Speed Effects

The General Vehicle Test Plans (GSP-064) define a ride roughness parameter in order to quantify the ride experienced by a typical passenger on a transit vehicle. Figures 3-8 and 3-9 show typical SLRV ride roughness values as a function of speed and car weight.

Figure 3-7 shows the vertical ride vibrations experienced on the centerline of the car over the location of the powered truck for the complete range of test speeds from 10 to 50 mph.

Weight Effects

In the SLRV, vertical accelerations increase with car weight in both of the predominant frequency ranges in the end car location (over powered trucks).

Figure 3-10 shows the change in vertical vibrations experienced in the same end car locations for two car weights (77,540 lb and 100,945 lb).

More in-depth evaluations of each of the six modes of vibration monitored are included in Volume III of this report. They cover vertical, lateral, and longitudinal vibration at car centerline for two longitudinal locations. The first location is over the end powered truck and the second location is in the articulation section over the unpowered truck.

3.2.4 Noise Tests

Wayside Noise Levels

The wayside noise measurements were made to determine the acoustic characteristics of the SLRV and to identify the primary noise contributions. Each major undercar equipment component was isolated and its contribution recorded. Additional test runs covered the speed range from 0 to 50 mph for cars representing all loading conditions from empty (AWO) to full crush loading. Also included in the test program was the effect of running the cars trained in pairs.

Figures 3-11 through 3-14 give a synopsis of the data acquired during this test sequence.

Interior Noise Levels

Interior noise level measurements were also made on the SLRV to determine the characteristics of the vehicle from the occupant viewpoint. Data was surveyed at locations representative of both seated and standing passengers as well as at the operator's seated ear level.

Care was taken to assure that no flats were discernable on the wheels and a clear dry atmosphere existed for all testing. Data was acquired from both a San Francisco series car and a Boston series car, the former having two-speed air circulation blowers, but no air conditioning whereas the latter car was air conditioned.

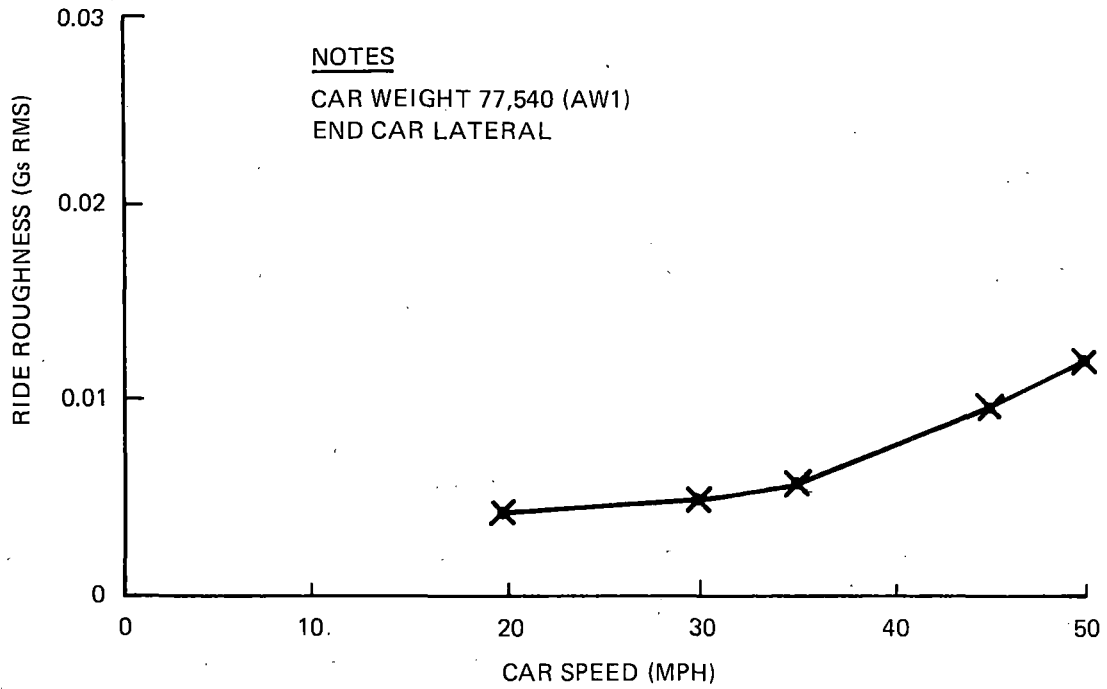

Figure 3-8. Effect of Speed on End Car Centerline Lateral Ride Roughness

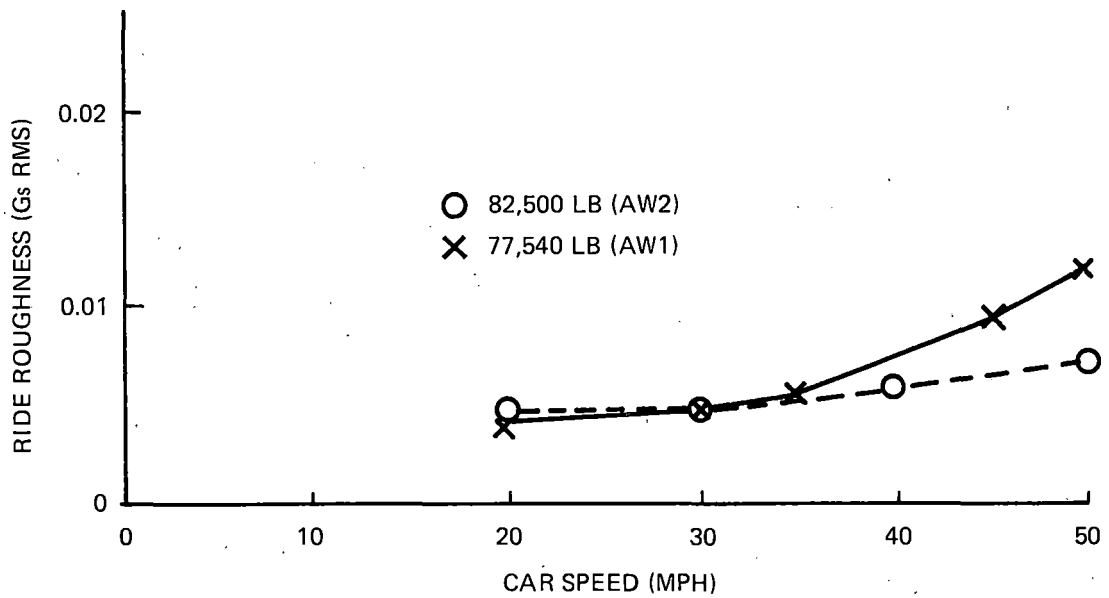

Figure 3-9. Effect of Speed on End Car Centerline Vertical Ride Roughness

NOTES

SPEED 50 MPH

END CAR VERTICAL ACCELERATIONS

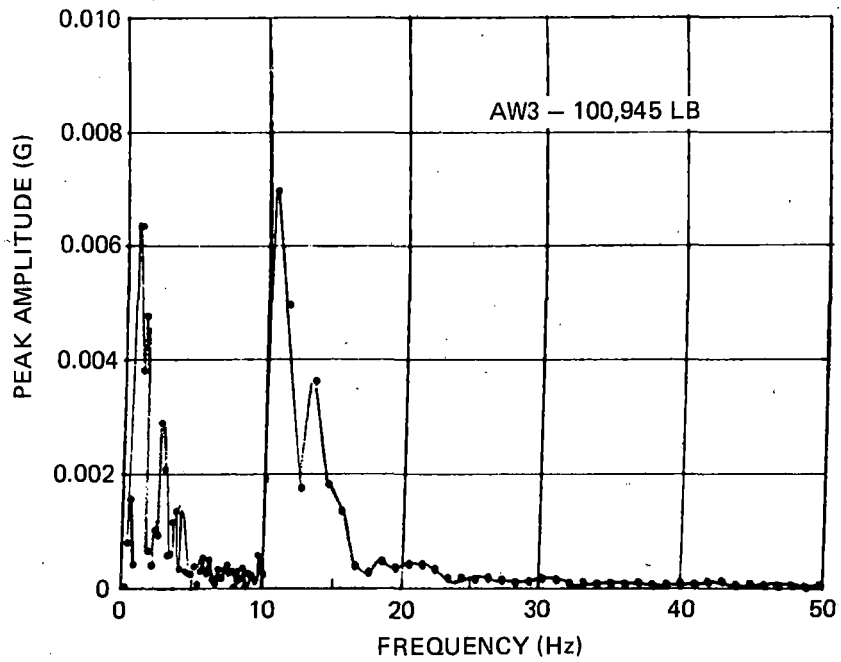
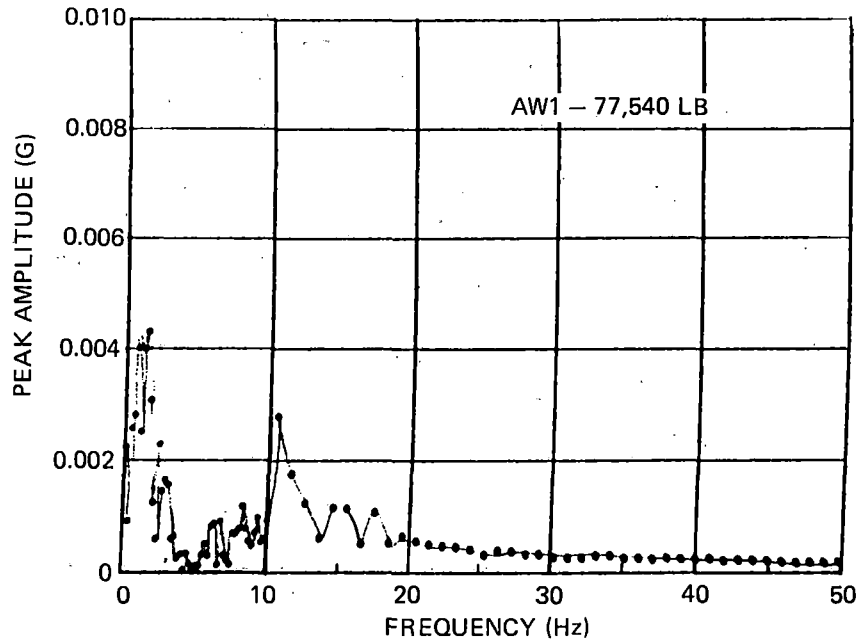

Figure 3-10. Ride Quality Baseline Comparison - Effect of Car Weight

NOTES

- 1. 50 FT FROM TRACK CENTERLINE
- 2. GROSS WEIGHT 69,130 LB
- 3. TRACK SECTION IV
(WELDED RAIL, CONCRETE TIES)

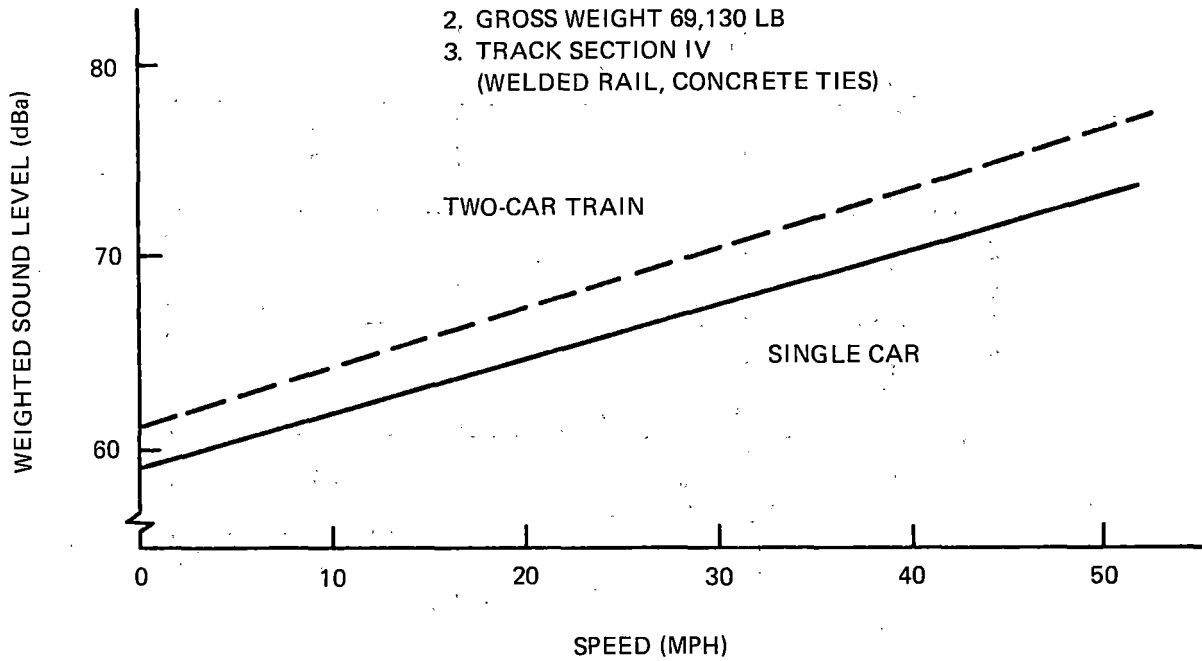

Figure 3-11. Effect of Speed on Wayside Noise

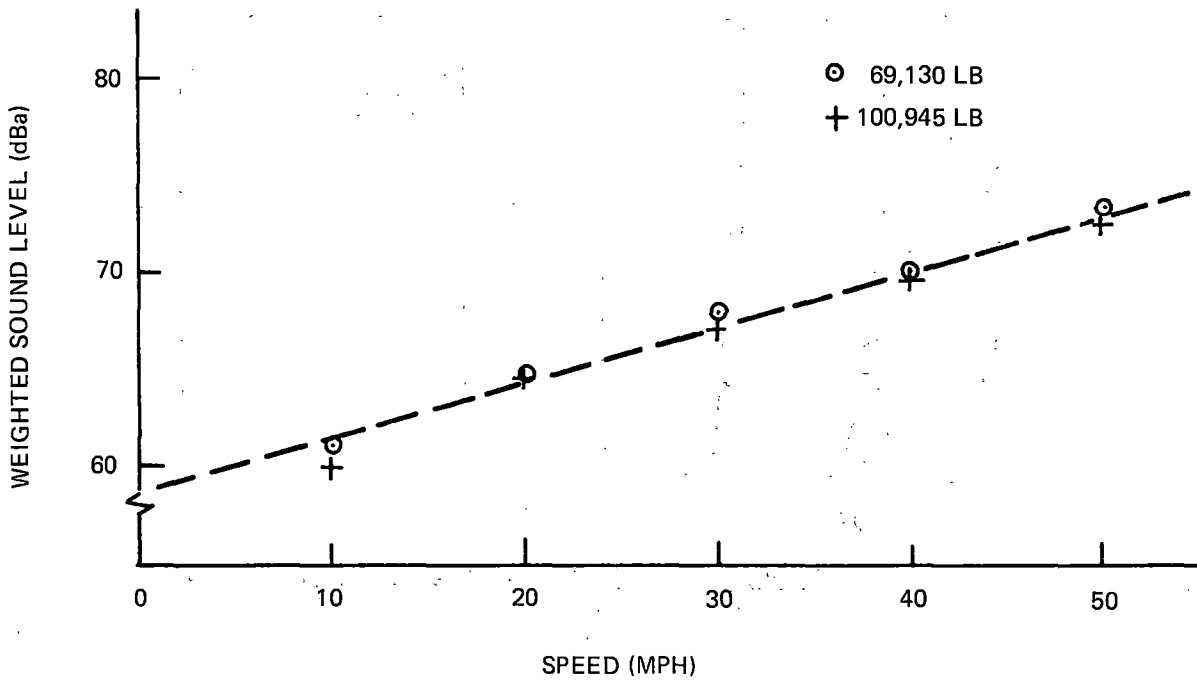

Figure 3-12. Effect of Vehicle Speed on Wayside Noise

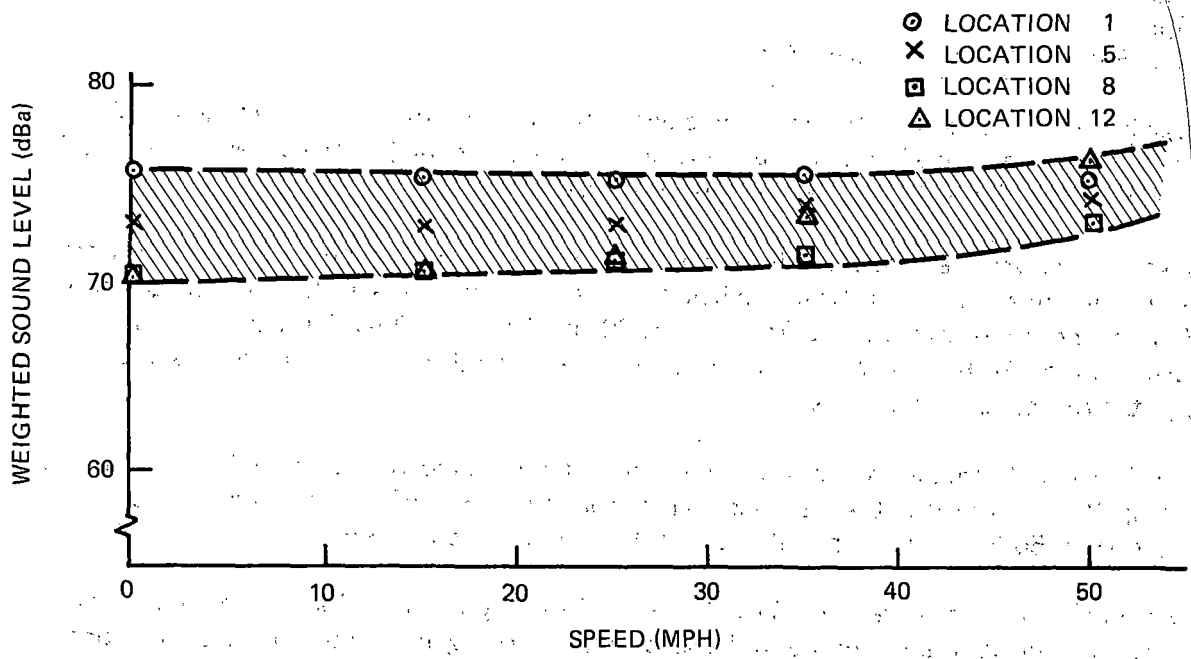

Figure 3-13. Noise Levels Versus Speed - Non-Air-Conditioned Car

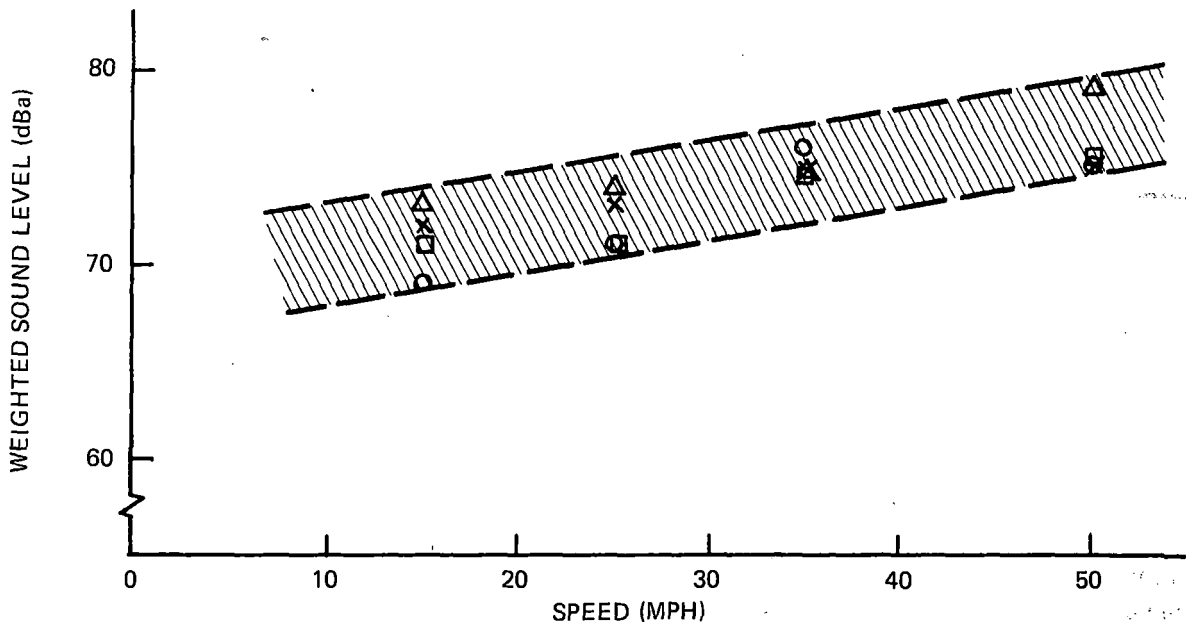

Figure 3-14. Noise Levels Versus Speed - Air Conditioned Car

A minimum of 15 seconds of data was recorded at each location for each of the selected speed conditions and continuous records were also taken during accelerations and decelerations in the 0 to 20 and 0 to 50 mph ranges.

3.2.5 Radio Frequency Interference

Broadband radiated electromagnetic emissions were measured from an MBTA and an SFMR car. Fifty-foot and one-hundred-foot wayside data were obtained. The converted data were compared with the RFI limits established for the SLRV.

Wayside tests were performed under ambient conditions and for various car operating states, i.e., maximum acceleration above and below base speed, constant speeds of 10, 20, 35, and 50 mph, and full service braking from 50, 35, 20 and 10 mph. The MBTA car was tested at AWO and the SFMR car at AW3. There was no substantial difference in the results obtained with the two car configurations.

The electric field emissions at a wayside distance of 100 feet were within the limits established for the SLRV over the entire frequency range from 14 KHz to 600 MHz. The emissions measured at 50 feet were even within the 100 ft limits above 200 KHz.

Corrected noise data is presented in Volume III of this report in the form of log frequency plots. This format is appropriate to the spectrum analyzer which records E-field emissions across a given frequency band on a continuous basis. The log frequency plot also provides a more comprehensive picture of the noise spectrum than is available with tabular listings.

APPENDIX A

TEST SET COVER SHEETS SHOWING TEST STATUS

TEST TITLE: ACCELERATION

TEST SET NUMBER: SLRV-P-2001-TT

TEST OBJECTIVE: To determine the overall acceleration characteristics of the SLRV as affected by master controller input, car weight, line voltage

TEST DESCRIPTION: The SLRV will be accelerated, at the AW0 car weight, to 20 mph using 575 line volts. The following combinations will be tested:

<u>PROCEDURE OPTIONS</u>	<u>PRIME VARIABLE</u>	<u>TEST CONDITIONS</u>
1	Master Controller	100%, 75%, 50%, 25% Acceleration
2	Car Weights	AW0, AW2, AW3
3	Line Voltage	575 (nominal), 475 (min.) and -700 volts (max)
4	Consist	Single & 2-Car Train

STATUS: The SLRV acceleration test was successfully completed during January 1976 (Runs 23, 25, 35, & 37) at the DOT-TTC facility in Pueblo, Colorado; on car SF-0002.

The acceleration rates for AW2 are as follows:

	<u>REQUIREMENT</u>	<u>TEST AW2</u>
Acceleration (mphps)	2.8 ± 10%	2.78
Time to 600 ft	20 sec	19.0-19.5 sec
Time to 50 mph	37 sec	33.9-34.2 sec

TEST TITLE: DECELERATION – BLENDED BRAKING

TEST SET NUMBER: SLRV-P-3001-TT

TEST OBJECTIVE: To determine the overall deceleration characteristics of the SLRV utilizing the blended braking system as affected by the master controller input, car weight and line voltage

TEST DESCRIPTION: The SLRV will be decelerated at the AW0 car weight, from 20 mph using 575 line volts. The following combination will be tested:

<u>PROCEDURE OPTION</u>	<u>PRIME VARIABLE</u>	<u>TEST CONDITIONS</u>
1	Car Speed	20, 30, 40 and 50 mph
2	Master Controller	100%, 75%, 50%, 25% Braking
3	Car Weight	AW0, AW2, AW3
4	Line Voltage	575 & 475 Volt (nominal)

STATUS: The SLRV blended braking tests were performed during January through March 1976 at DOT-TTC, Pueblo, Colorado, on Car No. SF0002. The following table presents the extremes of performance that were measured and the requirements for nominal braking rate on level tangent track.

	<u>SLRV SPEC</u>	<u>AW0</u>	<u>CAR WEIGHT</u>	
			<u>AW2</u>	<u>AW3</u>
Full-Service Blended Braking, Nominal Braking Rate (mphps)	3.5 ± 10% Average 3.0 Min 4.0 Max	3.57–3.85	3.59–3.72	3.35–3.62

TEST TITLE: DECELERATION – DYNAMIC BRAKING

TEST SET NUMBER: SLRV-P-3003-TT

TEST OBJECTIVE: To determine the overall deceleration characteristics of the SLRV utilizing the dynamic braking system as affected by the master controller input and car weight

TEST DESCRIPTION: The SLRV was decelerated at the AW0 car weight, from 20 mph using 575 line volts. The following combinations were tested:

<u>PROCEDURE OPTION</u>	<u>PRIME VARIABLE</u>	<u>TEST CONDITIONS</u>
1	Car Speed	20, 30, 40, 50 mph
2	Master Controller	100%, 75%, 50%, 25% Braking
3	Car Weight	AW0, AW2, AW3

STATUS: The SLRV dynamic braking tests were successfully completed during January & March 1976, Runs 38, 24, and 72. The tests were performed at the DOT-TTC test facility, Pueblo, Colorado, on car SF0002.

The summary table below displays the extremes of dynamic braking performance measured in the tests at car weights of AW0, AW2, and AW3.

	SPECIFICATION REQUIREMENT (REFERENCE B)	CAR WEIGHT		
		AW0	AW2	AW3
Dynamic Braking, Nominal Braking Rate (mphs)	2.8 ± 10%	2.74–2.85	2.84–2.95	2.80–2.87

TEST TITLE: DECELERATION – SERVICE FRICTION

TEST SET NUMBER: SLRV-P-3002-TT

TEST OBJECTIVE: To determine the overall deceleration characteristics of the SLRV utilizing the friction braking only system as affected by the master controller input and car weight

TEST DESCRIPTION: The SLRV will be decelerated at the AW0 car weight, from 20 mph using 575 line volts. The following combinations will be tested:

<u>PROCEDURE OPTION</u>	<u>PRIME VARIABLE</u>	<u>TEST CONDITIONS</u>
1	Car Speed	20, 30, 40, & 50 mph
2	Master Controller	100%, 75%, 50%, 25% Braking
3	Car Weight	AW0, AW2, AW3

STATUS: These SLRV performance test data, which consist of deceleration performance with friction only braking, were obtained from tests performed at DOT TTC, Pueblo, Colorado, during January 1976 on Car No. SF0002.

Deceleration tests with friction only braking (Runs 23, 35, 37, and 38) have been accomplished pursuant to GSP 064 procedures, to determine the performance characteristics of the SLRV under controlled conditions.

TEST TITLE: DECELERATION – EMERGENCY BRAKING

TEST SET NUMBER: SLRV-P-3004-TT

TEST OBJECTIVE: To determine the overall deceleration characteristics of the SLRV utilizing the emergency braking system as affected by car weight

TEST DESCRIPTION: The SLRV will be decelerated, at the AW0 car weight, from 20 mph using 575 line volts. The following combinations will be tested:

<u>PROCEDURE OPTION</u>	<u>PRIME VARIABLE</u>	<u>TEST CONDITIONS</u>
1	Car Speed	10, 20, 30, 40, and 50 mph
2	Car Weight	AW0, AW2, AW3

STATUS: SLRV performance tests for deceleration with emergency braking have been successfully performed at DOT-TTC Facility, Pueblo, Colorado, during January 1976 on Car SF0002.

Test runs 39, 24, and 35 were performed to satisfy the requirements.

TEST TITLE: DRIFT TEST

TEST SET NUMBER: SLRV-P-4001

TEST OBJECTIVE: To determine the traction (train) resistance of the SLRV for use in checking the Davis equation coefficients used to calculate the design performance of the vehicle, and as a baseline for analysis of the vehicle tractive and braking effort values

TEST DESCRIPTION: During the drift tests the SLRV train consist was allowed to coast from the initial speed on level tangent track. Both propulsion and friction brake systems were disabled to attain a true coast. The speed-time distance data is the source of the final resistance values. Testing was accomplished at AW2 car weight

<u>PROCEDURE OPTION</u>	<u>PRIME VARIABLE</u>	<u>TEST CONDITIONS</u>
1	Car Speed	Initial entry speed
2	Car Direction	Forward and reverse
3	Train Consist	Single and 2-car train

STATUS: Drift tests were successfully completed for a single car and two-car train on the DOT-TTC facility at Pueblo, Colorado, in June 1976 with cars SF0003 and MB0002.

AW2 - Single Car	Test 89 on 5/24/76	SF0002
AW2 - Single Car	Test 26 on 1/5/76	SF0002
AW2 - Single Car	Test 25 on 6/8/76	SF0003
AW2 - 2-car train	Test 30 on 6/15/76	SF0003/MB0002

TEST TITLE: SPIN/SLIDE ACCELERATION

TEST SET NUMBER: SLRV-P-2011-TT

TEST OBJECTIVE: To determine the efficiency of the test vehicles spin/slide protective system during acceleration for various rail conditions

TEST DESCRIPTION: The test was conducted on level tangent track at the desired rail condition. The SLRV was accelerated at full service rate beyond base speed allowing the spin/slide system to function.

PRIME VARIABLE

TEST CONDITION

Rail Condition

Clean, wet, dry

STATUS: Spin/slide tests were conducted with full acceleration starting from zero car speed and attaining up to 45 mph car speed. Spin conditions above base speed were not encountered on wet track and spin conditions were not apparent at any speed with dry track. Car weight was set at AWO for these tests.

Test No. 65 – Record 17 & 18

Dry track

Record 21 & 22

Clean wet

TEST TITLE: WHEEL SLIP/SLIDE (DECELERATION)

TEST SET NUMBER: SLRV-P-3011-TT

TEST OBJECTIVE: To determine the efficiency of the test vehicles spin/slide protection system during blended and friction only braking throughout the speed range of the vehicle for various rail conditions

TEST DESCRIPTION: The SLRV was decelerated at AWO car weight over a range of initial velocities using either full service blended braking or full service friction only braking. The tests were conducted on wetted rails allowing the slip/slide system to function. The following combinations were tested:

<u>PROCEDURE OPTION</u>	<u>PRIME VARIABLE</u>	<u>TEST CONDITIONS</u>
1	Car Speed	20, 30, 40, 50 mph
2	Brake Mode	Full Service Blended; Friction only

STATUS: Tests were conducted with full service friction and full service blended braking. Continuous slides were achieved at entry speeds over the range 20 to 50 mph.

The slip/slide efficiency measured during deceleration tests exceeded the minimum requirement (75%) relative to the vehicle specification.

TEST TITLE: POWER CONSUMPTION (DUTY-CYCLE)

TEST SET NUMBER: SLRV-PC-5011-TT

TEST OBJECTIVE: To determine the power consumption of the test vehicle while operating on a sample service route at a defined level of schedule performance. The test will provide a measure of car schedule performance, power consumption, and overall traction system efficiency.

TEST DESCRIPTION: The SLRV, at AW2 car weight, was operated on a simulated N-line duty cycle consisting of 93 station stops. The equivalent N-line round trip distance was completed in less than 58 minutes utilizing speeds of 26 mph and 50 mph and using blended braking only.

<u>PROCEDURE OPTION</u>	<u>PRIME VARIABLE</u>	<u>TEST CONDITIONS</u>
1	Braking	Full service blended, friction
2	Line Voltage	Min, Max, Nominal (575V)

STATUS: Testing was successfully completed for the simulated N-line duty cycle at the DOT-TTC facility in Pueblo, Colorado, with the results agreeing closely with the values predicted for the simulated route.

Test 36 – Record 16 Line Voltage (Nominal) 474

Test 37 – Record 4 Line Voltage (Nominal) 750

Test 38 – Record 3 Line Voltage (Nominal) 575

TEST TITLE: EQUIPMENT NOISE SURVEY

TEST SET NUMBER: SLRV-CN-0001-TT

TEST OBJECTIVE: To determine the contribution of equipment noise to total test vehicle signature

TEST DESCRIPTION: Noise measurements were made with the various items of undercar equipment operating individually and in combination. Measurements were taken at a range of distances from the vehicle.

STATUS: Surveys were conducted on:

1. Traction Motor Blowers
2. Equipment Cooling Blower
3. Low Voltage Power Supply
4. Air Brake Compressor
5. Air Conditioning Compressor

For each equipment item a complete lateral survey was conducted. Item 5 was taken on MB0001, all other data was recorded from cars SF0002 and SF0003.

TEST TITLE: EFFECT OF CAR SPEED – WAYSIDE

TEST SET NUMBER: SLRV-CN-1001-TT

TEST OBJECTIVE: Determine wayside noise levels during vehicle passbys during constant speed conditions

TEST DESCRIPTION: Measurements were taken at a wayside location 50 feet from smooth welded track on concrete ties for the following conditions:

<u>PROCEDURE OPTION</u>	<u>PRIME VARIABLE</u>	<u>TEST CONDITIONS</u>
1	Car Speed	Speeds from 10 to 50 mph
2	Car Weight	AW0, AW3
3	Train Consist	Single Car, two-car train

STATUS: The SLRV noise survey was conducted utilizing car SF0002 for single car runs and adding MB0002 for the multiple car data.

The data indicated a linear relationship between vehicle speed and measured noise. The maxima measured at 50 mph were below the specifications set for this vehicle design (80 dBa and 40 mph).

AW0, Single Car, SF2, Test 49

AW0, Two Car, SF2 and MB2, Test 59

AW3, Single Car, SF2, Test 52

TEST TITLE: EFFECT OF SPEED — "ON CAR" NOISE

TEST SET NUMBER: SLRV-PN-1001-TT

TEST OBJECTIVE: To determine noise levels inside the test vehicle while operating over a range of velocities

TEST DESCRIPTION: Measurements were taken in the test SLRV at several interior locations and at a range of operating velocities as indicated in the following conditions:

<u>PROCEDURE OPTION</u>	<u>PRIME VARIABLE</u>	<u>TEST CONDITIONS</u>
1	Car Velocity	15, 25, 35, and 50 mph
2	Car Weight	AW0, AW3
3	Recording Location	Four-car interior locations

STATUS: Testing was successfully completed on car SF0002 at the DOT-TTC facility in Pueblo, Colorado, in February 1976. Data was recorded with all car systems operating and at seat locations 5, 8, and 12 as well as at the operator's location.

Test 50, 51 AW0, $V_S = 15, 25, 35, 50$ SF0002 Single Car

Test 52, AW3, $V_S = 15, 25, 35, 50$ SF0002 Single Car

TEST TITLE: INTERIOR NOISE-SURVEY – CONSTANT VELOCITY

TEST SET NUMBER: SLRV-PN-1301-TT

TEST OBJECTIVE: To determine the noise characteristics of the test vehicle by a survey of various passenger locations

TEST DESCRIPTION: This test was performed at a single test vehicle weight (AW0) while operating at a constant speed.

STATUS: Testing was successfully completed on Car SF0002 at the DOT-TTC facility in Pueblo, Colorado, in February 1976. A systematic interior noise level survey was conducted at locations representative of the typical distribution of passengers in the test vehicle.

A test speed of 40 mph was selected as representative of high normal operating speed.

Test 51 – AW0 $V_S = 40$ mph, SF0002, Single Car

TEST TITLE: ACCELERATION EFFECT – "ON CAR" NOISE

TEST SET NUMBER: SLRV-PN-2001-TT

TEST OBJECTIVE: To determine noise levels inside the test vehicle while accelerating

TEST DESCRIPTION: This test was performed under the following conditions:

<u>PROCEDURE OPTION</u>	<u>PRIME VARIABLE</u>	<u>TEST CONDITION</u>
1	Car Weight	AW0, AW3
2	Interior Location	2 Positions

STATUS: Testing was successfully completed on Car SF0002 at the DOT-TTC facility at Pueblo, Colorado in February 1976. The vehicle was accelerated from 0 to 50 mph and data was accumulated from two locations within the vehicle (Seats 8 and 12). Two tests were made at car weights of AW0 and AW3.

Test 51 – AW0, $V_S = 0$ to 50 mph, SF0002, Single Car

Test 52 – AW3, $V_S = 0$ to 50 mph, SF0002, Single Car

TEST TITLE: DECELERATION EFFECT – "ON CAR" NOISE

TEST SET NO.: SLRV-PN-3001-TT

TEST OBJECTIVE: To determine noise levels inside the test vehicle while decelerating

TEST DESCRIPTION: This test was performed under the following conditions:

<u>PROCEDURE OPTION</u>	<u>PRIME VARIABLE</u>	<u>TEST CONDITION</u>
1	Car Weight	AW0, AW3
2	Interior Location	2 Positions
3	Braking Mode	100%, 50% Full Service Braking

STATUS: Testing was successfully completed on Car SF0002 at the DOT-TTC facility at Pueblo, Colorado, in February 1976. The vehicle was decelerated from 50 mph with 100% brakes and from 20 mph with 50% full service braking. Data was collected at two locations within the vehicle (Seats 8 and 12) for runs at car weights of AW0 and AW3.

Test 51 – AW0, $V_S = 50$ to 0 and 20 to 0 mph, SF0002, Single Car

Test 52 – AW3, $V_S = 50$ to 0 and 20 to 0 mph, SF0002, Single Car

TEST TITLE: RIDE ROUGHNESS – WORST SPEEDS

TEST SET NUMBER: SLRV-R-1101-TT

TEST OBJECTIVE: To determine worst steady vibration levels of the SLRV on the rail transit test track

TEST DESCRIPTION: The SLRV was operated at three car weights over a range of vehicle speeds up to a maximum of 50 mph.

The following combinations were tests:

<u>PROCEDURE OPTION</u>	<u>PRIME VARIABLE</u>	<u>TEST CONDITIONS</u>
1	Car Weight	AW1, AW2, AW3
2	Car Speed	10, 20, 30, 35, 45, 50 mph

STATUS: The SLRV ride roughness tests were successfully completed during February 1976 – Runs 53, 54, 55, and 56. The tests were performed at the DOT-TTC, Pueblo, Colorado, on Car SF0002.

Testing was conducted on both jointed and welded rail sections of track.

TEST TITLE: RADIO FREQUENCY INTERFERENCE

TEST SET NUMBER: SLRV-PSI-6001-TT

TEST OBJECTIVE: To measure the broadband radiated electromagnetic emissions from the Standard Light Rail Vehicle. Wayside emissions data shall be obtained for comparison with the radio frequency interference limits established for SLRV.

TEST DESCRIPTION: Test data shall be obtained with the test vehicle passing by a wayside station under each of the following conditions:

1. Acceleration above and below base speed
2. Constant speed
3. Braking

In addition, a supplemental EMI test program will be conducted to provide data in the low-frequency range (30 hz to 30 KHz) and will be directed at the measurement of magnetic fields. The entire test program shall be conducted on one SFMR car and one MBTA car.

STATUS: The SLRV radio frequency interference tests were successfully completed during the period April 7 through May 6, 1976, at the DOT-TTC facility in Pueblo, Colorado. The SFMR car was tested at AW2; the MBTA car at AW0. There was substantially no difference in the test results between the two vehicle configurations. The electric field emissions at a distance of 100 feet from the vehicle were within the limits established for the SLRV over the entire test frequency range of 0.014 to 600 MHz. In addition, the emissions at 50 feet were within the limits from 0.200 to 600 MHz. The maximum magnetic flux density is localized in the articulation section. Correlation with the magnetic field profile at the pantograph indicates that the source of this is the 600V wiring from the pantograph to the undercar components. Propulsion control components in the B unit, particularly those located in the chopper locker, cause a 10 dB higher ambient magnetic field inside the B unit as compared with the A unit. Emissions from nonpropulsion components were minimal and had no impact on the internal magnetic field profile of the SLRV.

APPENDIX B
PATENTS DISCLAIMER

Although no patentable items are claimed, this research and development study has produced baseline information against which future vehicles may be compared.