

UMTA-MA-06-0153-85-8  
DOT-TSC-UMTA-86-6



U.S. Department  
of Transportation

**Urban Mass  
Transportation  
Administration**

# **Inductive Interference in Rapid Transit Signaling Systems**

## **Volume II: Suggested Test Procedures**

---

Transportation Systems Center  
Cambridge, MA 02142

March 1987  
Final Report

This document is available to the public  
through the National Technical Information  
Service, Springfield, Virginia 22161.

**UMTA Technical Assistance Program**

**NOTICE**

**This document is disseminated under the sponsorship of the Department of Transportation in the interest of information exchange. The United States Government assumes no liability for its contents or use thereof.**

**NOTICE**

**The United States Government does not endorse products of manufacturers. Trade or manufacturers' names appear herein solely because they are considered essential to the object of this report.**

1. Report No. UMTA-MA-06-0153-85-8		2. Government Accession No.		3. Recipient's Catalog No.	
4. Title and Subtitle Inductive Interference in Rapid Transit Signaling Systems Volume II: Suggested Test Procedures				5. Report Date March 1987	
				6. Performing Organization Code DTS-77	
7. Author(s)				8. Performing Organization Report No. DOT-TSC-UMTA-86-6	
9. Performing Organization Name and Address U.S. Department of Transportation Research and Special Programs Administration Transportation Systems Center Cambridge, MA 02142				10. Work Unit No. (TRIS) UM564/R5633	
				11. Contract or Grant No.	
				13. Type of Report and Period Covered Final Report July 1979 - June 1986	
12. Sponsoring Agency Name and Address U.S. Department of Transportation Urban Mass Transportation Administration Office of Technical Assistance Office of Systems Engineering Washington, DC 20590				14. Sponsoring Agency Code URT-10	
				15. Supplementary Notes	
16. Abstract  <p>Methods for detecting and quantifying the levels of inductive electromagnetic interference produced by solid state rapid transit propulsion equipment and for determining the susceptibility of signaling systems to these emissions are presented. These methods include procedures for taking measurements in the field, in the laboratory and on track circuits.</p> <p>As background, the mechanisms of inductive electromagnetic interference are described, as are audio-frequency track circuits and solid-state propulsion control. Recording and documentation procedures for applying these suggested test procedures are provided.</p> <p>Appendix A contains definitions of terms and systems of units. Appendix B contains sample outputs of tests using inductive recommended practices.</p>					
17. Key Words Inductive EMI Rail System EMI EMI Measurements			18. Distribution Statement  DOCUMENT IS AVAILABLE TO THE PUBLIC THROUGH THE NATIONAL TECHNICAL INFORMATION SERVICE, SPRINGFIELD VIRGINIA 22161		
19. Security Classif. (of this report) <b>UNCLASSIFIED</b>		20. Security Classif (of this page) <b>UNCLASSIFIED</b>		21. No. of Pages 76	22. Price

# METRIC CONVERSION FACTORS

## Approximate Conversions to Metric Measures

Symbol	When You Know	Multiply by	To Find	Symbol
<b>LENGTH</b>				
in	inches	2.5	centimeters	cm
ft	feet	30	centimeters	cm
yd	yards	0.9	meters	m
mi	miles	1.6	kilometers	km
<b>AREA</b>				
in <sup>2</sup>	square inches	6.5	square centimeters	cm <sup>2</sup>
ft <sup>2</sup>	square feet	0.09	square meters	m <sup>2</sup>
yd <sup>2</sup>	square yards	0.8	square meters	m <sup>2</sup>
mi <sup>2</sup>	square miles	2.6	square kilometers	km <sup>2</sup>
	acres	0.4	hectares	ha
<b>MASS (weight)</b>				
oz	ounces	28	grams	g
lb	pounds	0.45	kilograms	kg
	short tons (2000 lb)	0.9	tonnes	t
<b>VOLUME</b>				
tsp	teaspoons	5	milliliters	ml
Tbsp	tablespoons	15	milliliters	ml
fl oz	fluid ounces	30	milliliters	ml
c	cups	0.24	liters	l
pt	pints	0.47	liters	l
qt	quarts	0.95	liters	l
gal	gallons	3.8	liters	l
ft <sup>3</sup>	cubic feet	0.03	cubic meters	m <sup>3</sup>
yd <sup>3</sup>	cubic yards	0.76	cubic meters	m <sup>3</sup>
<b>TEMPERATURE (exact)</b>				
°F	Fahrenheit temperature	5/9 (after subtracting 32)	Celsius temperature	°C

## Approximate Conversions from Metric Measures

Symbol	When You Know	Multiply by	To Find	Symbol
<b>LENGTH</b>				
mm	millimeters	0.04	inches	in
cm	centimeters	0.4	inches	in
m	meters	3.3	feet	ft
m	meters	1.1	yards	yd
km	kilometers	0.6	miles	mi
<b>AREA</b>				
cm <sup>2</sup>	square centimeters	0.16	square inches	in <sup>2</sup>
m <sup>2</sup>	square meters	1.2	square yards	yd <sup>2</sup>
km <sup>2</sup>	square kilometers	0.4	square miles	mi <sup>2</sup>
ha	hectares (10,000 m <sup>2</sup> )	2.5	acres	
<b>MASS (weight)</b>				
g	grams	0.035	ounces	oz
kg	kilograms	2.2	pounds	lb
t	tonnes (1000 kg)	1.1	short tons	
<b>VOLUME</b>				
ml	milliliters	0.03	fluid ounces	fl oz
l	liters	2.1	pints	pt
l	liters	1.06	quarts	qt
l	liters	0.26	gallons	gal
m <sup>3</sup>	cubic meters	36	cubic feet	ft <sup>3</sup>
m <sup>3</sup>	cubic meters	1.3	cubic yards	yd <sup>3</sup>
<b>TEMPERATURE (exact)</b>				
°C	Celsius temperature	9/5 (then add 32)	Fahrenheit temperature	°F

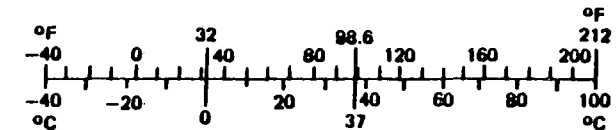
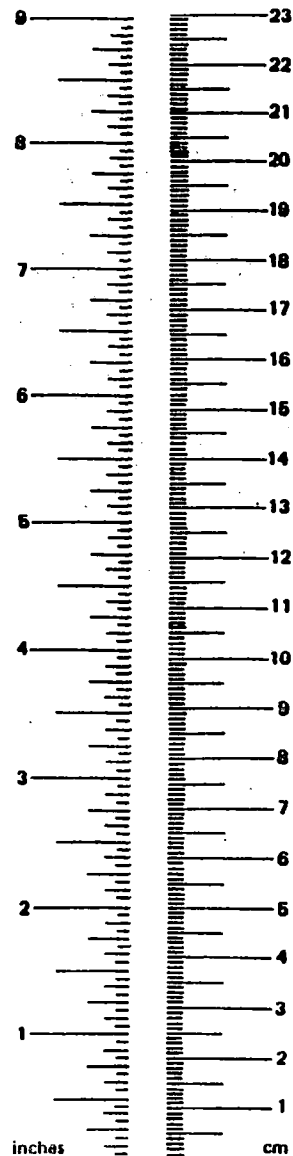

\* 1 in. = 2.54 cm (exactly). For other exact conversions and more detail tables see NBS Misc. Publ. 288, Units of Weight and Measures. Price \$2.26 SD Catalog No. C13 10 286.

## PREFACE

These suggested test procedures have been prepared by the Rail Transit Electromagnetic Interference and Compatibility (EMI/EMC) Technical Working Group (TWG) as part of a cooperative effort between the Federal Government -- the Urban Mass Transportation Administration (UMTA) and the Transportation Systems Center (TSC) of the U.S. Department of Transportation -- and the transit industry to develop standard methods of analysis and testing to quantify and resolve issues of electromagnetic compatibility (EMC) in rail transit operation.

This activity, over the past 7 years, has kept pace with the development of new propulsion and signaling techniques. To date, a number of suggested test procedures have been tested extensively and applied in the process of assuring compatibility between propulsion and signaling for a number of new and upgraded U.S. rail transit systems. The experience thus gained has been incorporated, along with suggestions and comments received from the rail transit operator and supply industries and their consultants, in preparing the finished versions of these suggested test procedures.

The suggested test procedures that have reached this final form address compatibility between rail transit propulsion systems and auxiliary power systems employing solid-state control of dc power, and signaling system track circuits. Solid-state control of propulsive and auxiliary power is characteristic of the types of equipment currently or soon to be available in new and upgraded U.S. rail transit systems.

The test procedures presented herein initially were developed to address compatibility of dc chopper propulsion control systems and audio-frequency (300 Hz-20 kHz) signaling systems. Since choppers operate at frequencies of 200 to 400 Hz, their harmonics cannot interfere with power-frequency (25-100 Hz) track circuits. However, since ac inverters sweep through frequencies used in both power-frequency and audio-frequency signaling, the test procedures have been extended to address compatibility of solid-state propulsion control systems with power-frequency signaling systems, and they have been applied successfully for this purpose.

Three salient types of electrical interference are dealt with in suggested test procedures developed by the TWG - conductive, inductive, and radiated. Radiated EMI has not been found to impact either power-frequency or audio-frequency signaling, but it poses a potential problem with radio and TV reception near surface rapid transit lines, and therefore warrants assessment.

These procedures are subject to change as improved methods and techniques are developed, and as more advanced equipment becomes available. The Standards and Foreign Practices Subcommittee of the Institute of Electrical and Electronic Engineers (IEEE) Land Transportation Committee has agreed to augment and update them periodically as required. The IEEE should be contacted in the future for up-to-date information on test procedures.

The Rail Transit EMI/EMC Technical Working Group includes representatives from the following manufacturers of rail transit equipment and industry consultants:

Brown Boveri Canada, Inc.

Garrett Corporation

General Electric Company

General Railway Signal Company

Union Switch & Signal Division, American Standard, Inc.

Westinghouse Electric Corporation

Comstock Engineering, Inc.

Ohio Brass, Inc.

Siemens-Allis, Inc.

Frasco & Associates, Inc.

## TABLE OF CONTENTS

<u>PART</u>	<u>Page</u>
1. INTRODUCTION TO INDUCTIVE INTERFERENCE MECHANISMS IN RAIL TRANSIT SYSTEMS USING SOLID-STATE PROPULSION CONTROL.....	1-1
1. Introduction.....	1-1
2. Track Circuits.....	1-1
3. Solid-State Propulsion Control.....	1-5
4. Inductive Interference.....	1-9
5. Conclusions.....	1-17
6. References.....	1-17
2. REPORT FORMATS, RECORDING AND DOCUMENTATION PROCEDURES....	2-1
1. Scope.....	2-1
2. Format.....	2-1
3. Test Reporting Requirements.....	2-2
3. INDUCTIVE SUGGESTED TEST PROCEDURES.....	3-1
Method RT/IS01A Inductive Susceptibility of Audio-Frequency Rate-Coded Signaling Systems from 300 Hz to 10 kHz.....	3-1
Method RT/IE01A Inductive Emissions of Vehicular Electrical Power Subsystem, Rail-to-Rail Voltage from 20 Hz to 20 kHz.....	3-7
Method RT/IE04A Inductive Emissions of Vehicular Electrical Power Subsystem, Emulated Track Circuit.....	3-16
Method RT/IE04A Exhibit A - Simulation of Rail-Wheel-Axle Impedance.....	3-24
APPENDIX A - DEFINITIONS AND SYSTEMS OF UNITS.....	A-1
APPENDIX B - SAMPLE TEST OUTPUTS USING INDUCTIVE SUGGESTED TEST PROCEDURES.....	B-1

## LIST OF FIGURES

<u>Figure</u>		<u>Page</u>
1-1	JOINTLESS AUDIO-FREQUENCY TRACK CIRCUIT	1-2
1-2	AUDIO-FREQUENCY TRACK CIRCUITRY	1-3
1-3	A SINGLE-RAIL POWER-FREQUENCY TRACK CIRCUIT	1-4
1-4	TYPICAL CHOPPER PROPULSION CONTROLLER	1-6
1-5	THREE-PHASE AC INVERTER PROPULSION SYSTEM	1-8
1-6	GENERATION OF INDUCTIVE INTERFERENCE	1-9
1-7	EQUIVALENT ELECTRICAL CIRCUIT-INDUCTIVE EMISSION	1-11
1-8	TRACK MONITORING CIRCUIT	1-13
1-9	PLOT OF SOURCE INDUCTANCE VERSUS $d$	1-13
1-10	RAIL-TO-RAIL VOLTAGE AT THREE DIFFERENT TIMES DURING PASSAGE OF MARTA CAR	1-14
1-11	SPECTRUM OF RAIL-TO-RAIL VOLTAGE $V_R$	1-15
1-12	MARTA RUN NO. 58 FULL POWER	1-16
RT/IS01A-1	ARRANGEMENT OF TEST APPARATUS FOR PERFORMING MEASUREMENT OF INDUCTIVE SUSCEPTIBILITY OF SIGNALING SYSTEMS	3-3
RT/IS01A-2	SAMPLE DATA SHEET	3-6
RT/IE01A-1	TEST SETUP FOR DATA COLLECTION	3-9
RT/IE01A-2	TEST SETUP FOR LAB REDUCTION OF DATA	3-12
RT/IE04A-1	TEST SETUP	3-18
RT/IE04A-A1	INDUCTANCE OF LONG RETURN CIRCUIT	3-26
RT/IE04A-A2	EQUIVALENT CIRCUIT OF UNDERCAR NETWORK	3-28



## EXECUTIVE SUMMARY

Electromagnetic interference, generated by rail transit propulsion equipment, can cause a transit system's signaling system to malfunction, resulting in potential reliability and safety problems. These problems have been complicated and increased by the introduction and growing use of new types of solid state propulsion control.

Two types of electromagnetic interference -- inductive and conductive -- have been found to be the major sources of electromagnetic incompatibility between propulsion and signaling subsystems in rail transit operations. The mechanism of inductive interference is described in Part 1 of this volume, as are audio-frequency track circuits and solid-state propulsion control.

In response to the electromagnetic interference and compatibility problem, the Urban Mass Transportation Administration (UMTA), the transit supply industry and its consultants, and the transit operators themselves have developed, tested, applied, and refined a number of suggested test procedures to ensure compatibility between propulsion and signaling equipment in U.S. transit systems.

Note that these are only suggested test procedures designed to acquire valid data. In-depth knowledge of instrumentation procedures and techniques is required to assemble and operate the equipment configurations described herein. The analysis, evaluation and interpretation of data collected will require detailed knowledge of the systems being examined as well as of various data reduction techniques. It is recommended that only experienced personnel conduct these tests and that all safety precautions be observed during test conduct.

These procedures are tested methods for determining the susceptibility of signaling systems to electromagnetic interference, and for measuring the electromagnetic emissions of electrical power subsystems in the field, in the laboratory, and in track circuits.

Appendices to this report include definitions of terms and systems of units, and sample outputs of tests using the suggested test procedures.

PART 1.  
INTRODUCTION TO INDUCTIVE INTERFERENCE MECHANISMS IN  
RAIL TRANSIT SYSTEMS USING SOLID-STATE PROPULSION CONTROL

## 1. INTRODUCTION

This presentation is a brief review of the mechanisms that produce inductive interference in the track circuits of rail transit systems employing solid-state propulsion control. A more detailed account is presented in other reports. (Refs. 1-1 and 1-2.)

## 2. TRACK CIRCUITS

### 2.1 Audio-Frequency Track Circuits

Figure 1-1 shows a typical jointless audio-frequency track circuit of the type employed at MARTA, WMATA, and portions of the MBTA, CTA, and Cleveland, as well as the new Baltimore and Miami systems. In this type of system, rate-coded bursts of audio-frequency current are injected by means of resonant impedance bonds at the transmitting ends of track blocks, and are received at the receiving ends of the blocks. A number of audio carrier frequencies are used cyclically down the track. Figure 1-2 shows typical track circuitry in detail.

### 2.2 Power-Frequency Track Circuits

Power frequency track circuits, which are used on some older systems, operate at frequencies from 25 to 300 Hz. Figure 1-3 shows one track circuit in a power-frequency signaling system. Power-frequency track circuits operate similarly to audio frequency circuits in that the track circuit signal path is completed through the transmitter, running rails and the receiver relay. The major difference is that power frequency circuits employ insulated joints instead of impedance bonds to electrically isolate and define adjacent blocks so that only the current associated with a block signal circuit flows in that signal block. Block occupancy by a train's wheel-axle assembly shunts the signal path, de-energizing the relay and activating a block occupied signal. When a block is unoccupied the relay is energized and a block unoccupied signal is activated. Reference 1-3 provides detailed information on the operation of power-frequency track circuits.

1-2

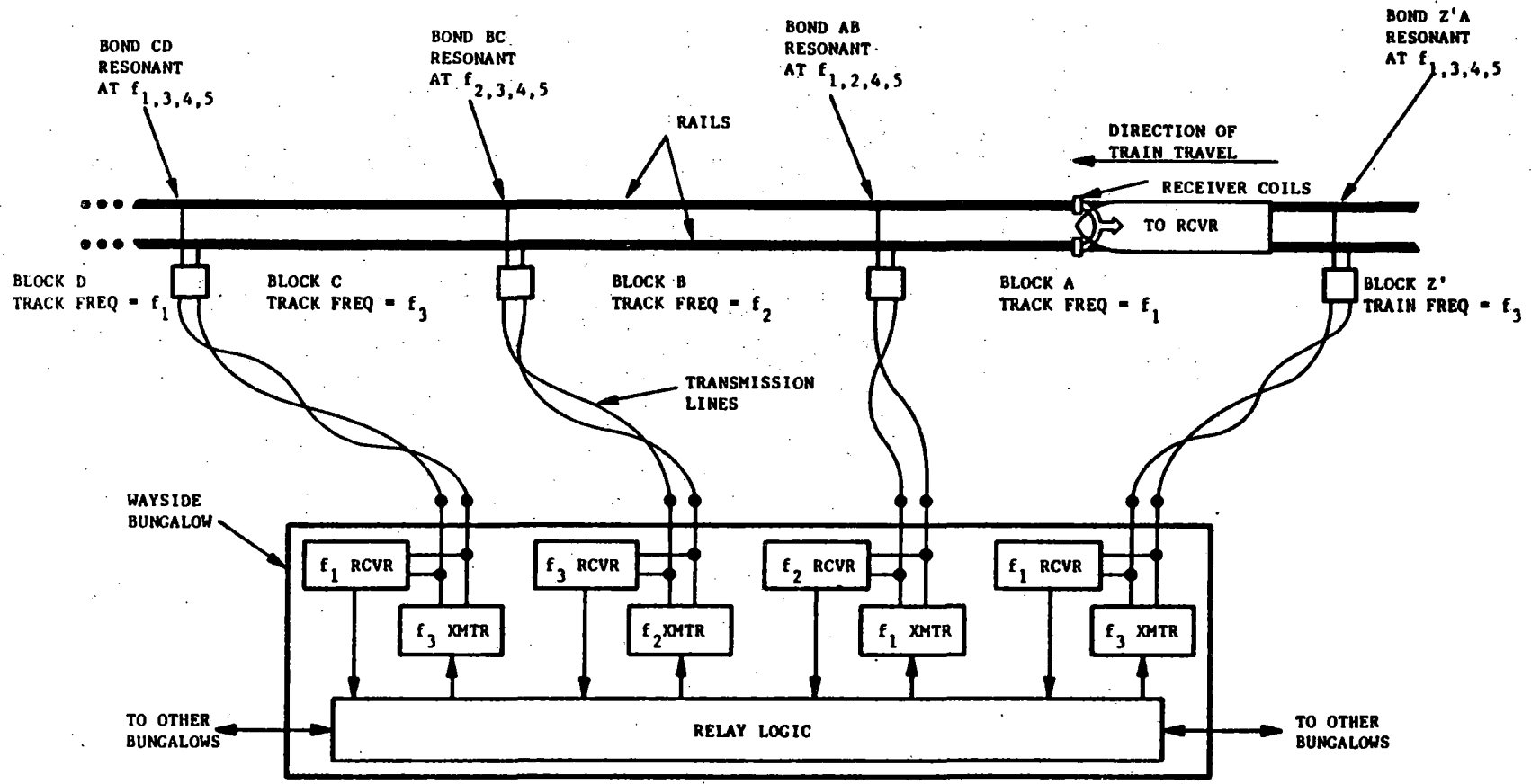

FIGURE 1-1. JOINTLESS AUDIO-FREQUENCY TRACK CIRCUIT

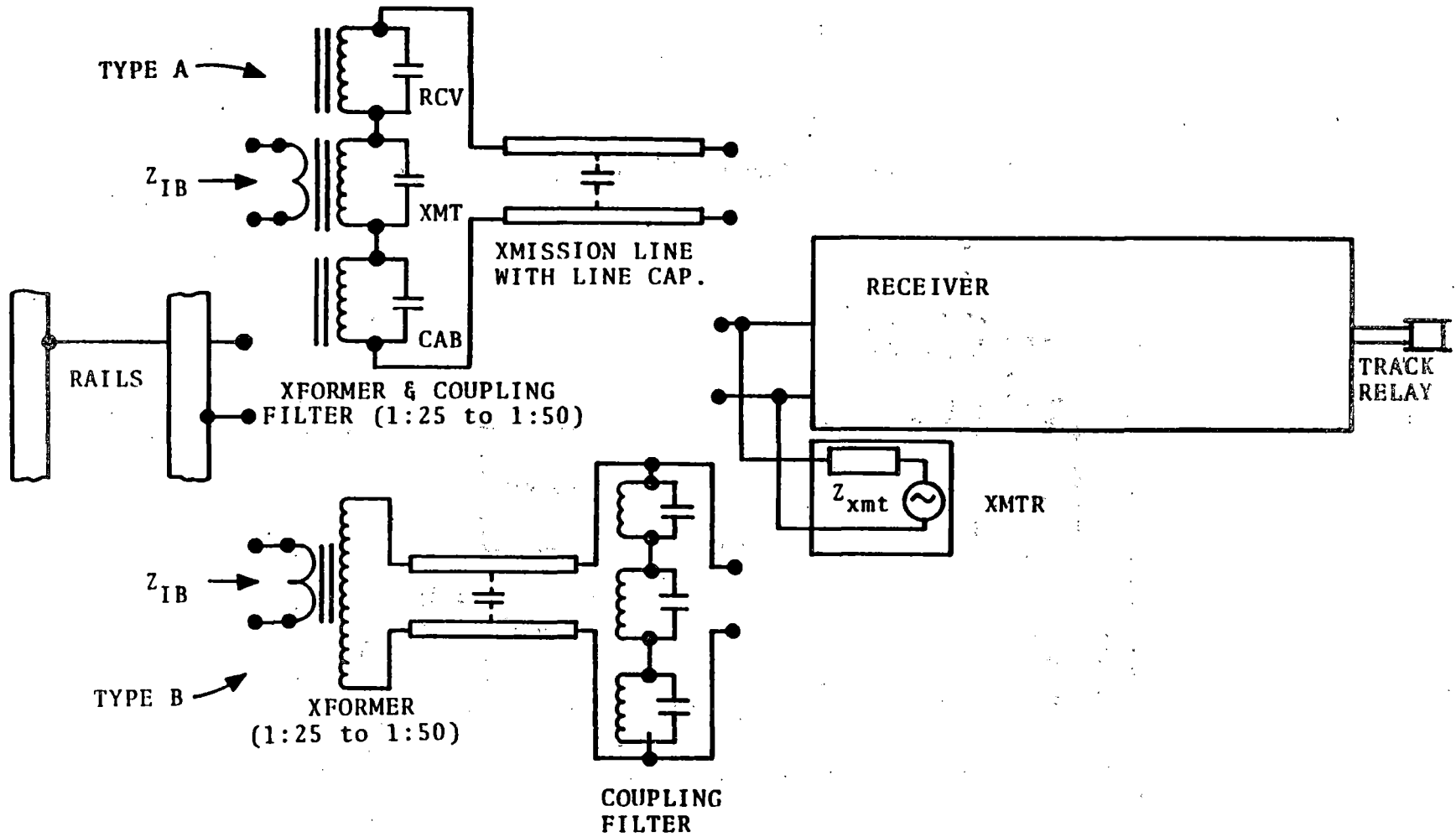
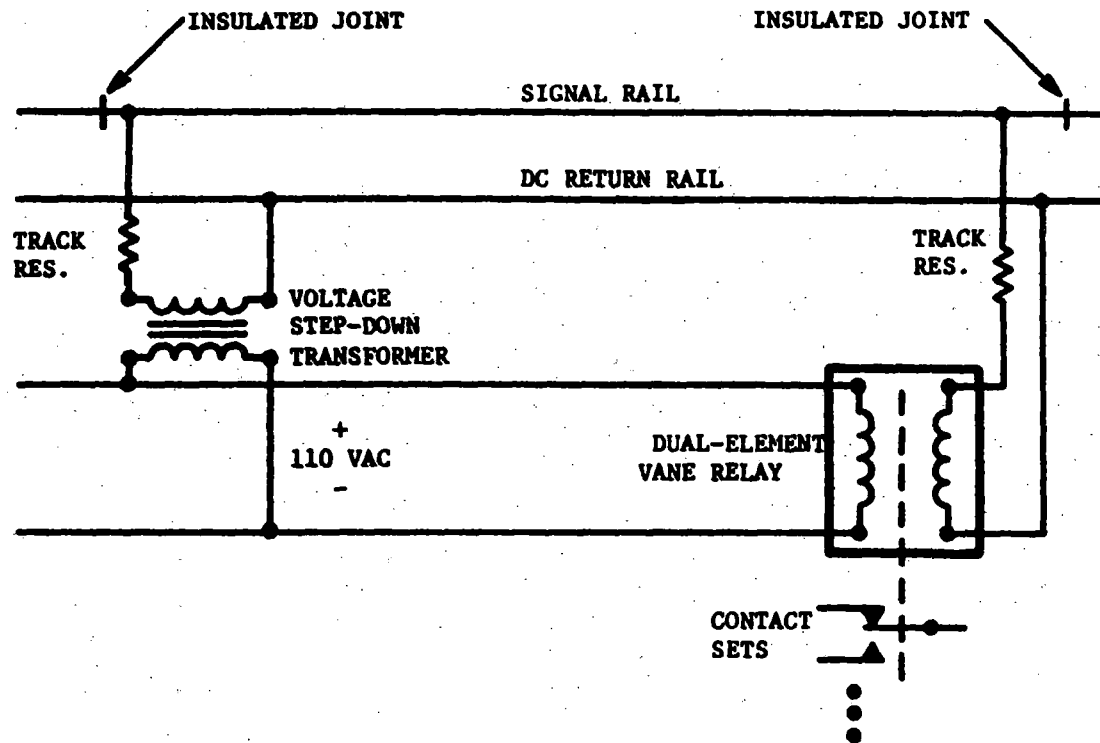

FIGURE 1-2. AUDIO-FREQUENCY TRACK CIRCUITRY



1-4

FIGURE 1-3. A SINGLE-RAIL POWER-FREQUENCY TRACK CIRCUIT

### 3. SOLID-STATE PROPULSION CONTROL

#### 3.1 Description

Two types of solid-state propulsion control currently are in use in rapid transit systems. These are dc chopper propulsion control, and ac inverter propulsion control. In both types of solid-state control, high-power solid-state circuits are used to control the flow of electrical power to traction motors, in place of control circuits employing rheostats or switched resistors.

DC chopper propulsion control systems are used to control the flow of dc electrical power from the third rail or overhead catenary to dc traction motors. AC inverter propulsion control systems are used to control the flow of dc electrical power from the third rail or catenary, and to transform the electrical power into polyphase ac power for delivery to polyphase ac motors used for traction. Three-phase ac induction motors are the current standard for ac propulsion.

Of the two types of solid-state control, dc control was developed first, and its use today is more widespread. A growing number of transit systems currently use ac propulsion, and development of ac propulsion control techniques is still continuing. Descriptions of both types of control circuitry, and their interference characteristics, are given below.

#### 3.2 DC Chopper Propulsion Control

Figure 1-4 shows a typical chopper circuit that might be used for dc propulsion control. In operation, propulsive power is controlled by varying the fraction of time that the main thyristor  $T_M$  stays on.  $T_M$  is gated on to initiate application of the line voltage to the motor. Some time later,  $T_C$ , the commutation thyristor, is gated on to trigger an oscillatory loop current around the  $T_M$ ,  $T_C$ ,  $L_C$ ,  $C_C$  loop. At some point during the first cycle of this oscillatory loop current, the algebraic sum of motor current and oscillatory loop current through  $T_M$  will go to zero, allowing  $T_M$  to turn off. Repetition frequency for gating  $T_M$  on is typically in the 200-400 Hz range, and the oscillatory frequency provided by  $L_C$  and  $C_C$  is typically ten times as high.

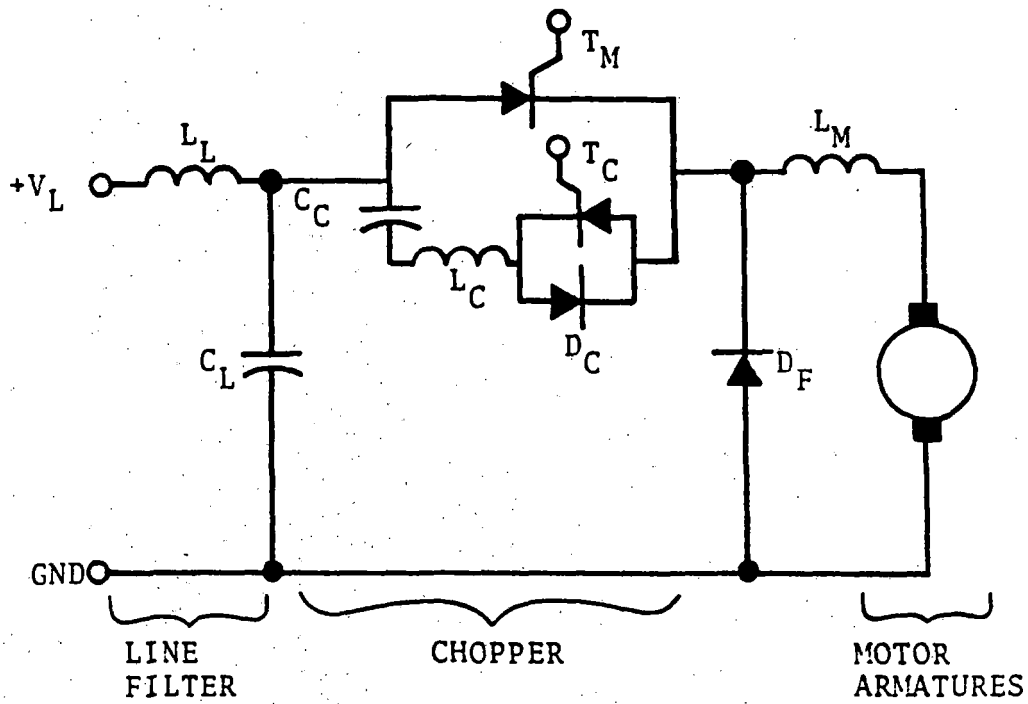

FIGURE 1-4. TYPICAL CHOPPER PROPULSION CONTROLLER

### 3.3 AC Inverter Propulsion Control

One type of ac propulsion system, developed by Oy Strömberg AB of Finland, and under further development for the U.S. market by the Garrett Corporation, is discussed here. As shown in Figure 1-5, this type of system employs a dc chopper much like that shown in Figure 1-4 to step dc voltage from the third rail up or down for supply to the inverter. The inverter consists of a bank of additional thyristor switch circuits that provide pulsating current at variable frequency to the three phases of the traction motors. Each phase of the inverter employs a thyristor switch to provide positive current and another one to provide negative current. As in the dc chopper circuit shown in Figure 1-3, for every thyristor that conducts power, there is a commutation circuit consisting of an LC circuit and another thyristor, to turn off the power thyristor.

Other ac propulsion systems dispense with the dc chopper and use inverter circuits by themselves. In these systems, pulse width modulation of current pulses to the three phases is used to control power.

### 3.4 Gate-Turnoff Thyristors

Semiconductor manufacturers have developed a type of thyristor, called the gate-turnoff (GTO) thyristor, that can be turned off by application of an electrical pulse to the thyristor's control gate. GTO power thyristors obviate the need for commutation circuits. Their use in both dc choppers and ac inverters is under development. As is seen in the discussion below, elimination of commutation circuit inductors will ease the job of assuring electromagnetic compatibility between rapid transit propulsion and signaling systems.

### 3.5 Interference Generation

Two possible modes of audio-frequency interference immediately are evident. The first, called the inductive mode, can arise because of high levels of stray magnetic flux rich in audio-frequency transients emanating from the inductive circuit components. The second, called the conductive mode (Refs. 1-4 and 1-5), can arise due to harmonics of the audio-frequency transient current waveforms present in propulsion control circuits getting past the line filter ( $L_L$ ,  $C_L$ ).



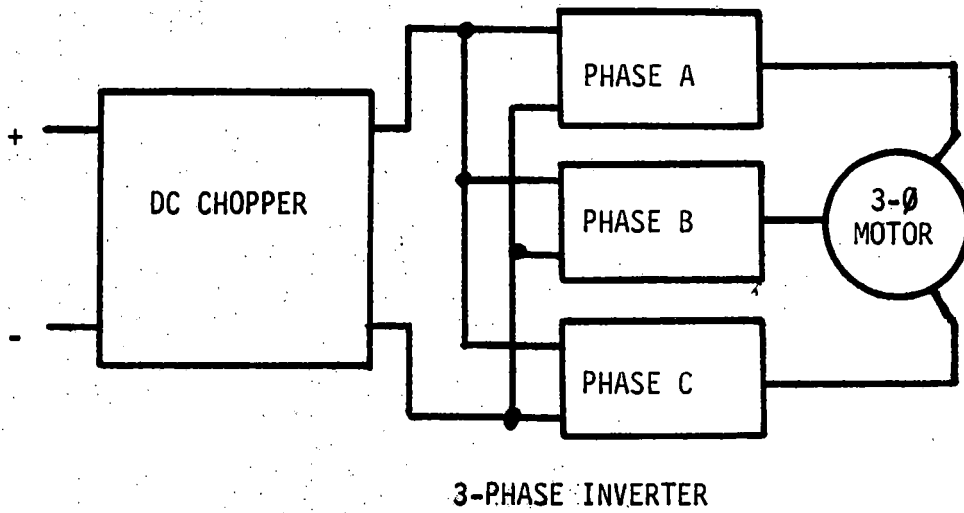

FIGURE 1-5. THREE-PHASE AC INVERTER PROPULSION SYSTEM

In both of these modes, interfering signals can be produced at harmonics of the fundamental chopper frequency, throughout the portion of the audio spectrum used for signaling.

#### 4. INDUCTIVE INTERFERENCE

##### 4.1 Inductive Interference Production

Figure 1-6 depicts the mechanism whereby magnetic flux from the magnetic components of the propulsion control system induces interference voltage in the signaling system. When the rapid transit car is immediately over an impedance bond as shown in Figure 1-6, the signal current that would be received at that bond is shunted by the axles of the vehicle, thus normally causing the track relay to drop. However, magnetic flux lines from the propulsion control box, normally slung under the vehicle, can pass through the loops formed by rail, axle, and bond leads, and cause a transient-induced voltage across the track terminals of the impedance bond. Inductive interference is evidenced by the observation of abnormally high levels of rail-to-rail voltage observed at locations under the vehicle. This induced voltage has a harmonic spectrum that spans the frequency range typically used for audio-frequency signaling.

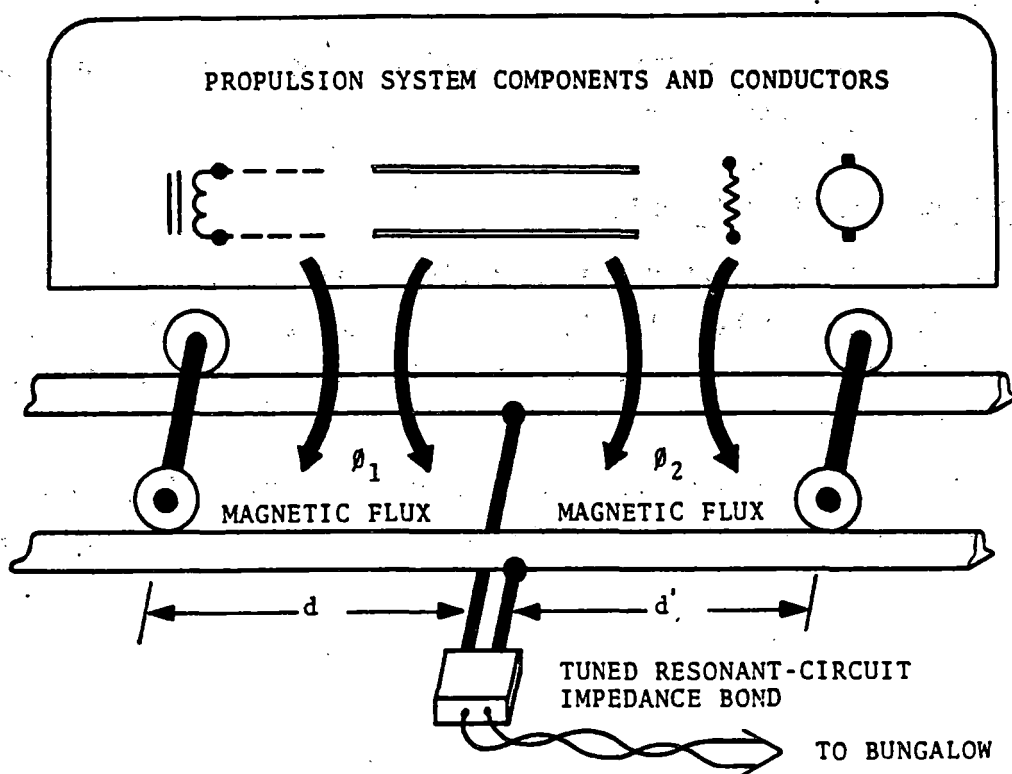

FIGURE 1-6. GENERATION OF INDUCTIVE INTERFERENCE

Different operational modes and speeds of the train, in acceleration, steady running, coasting, and braking, result in different amounts of observed interference. Such interference has been observed in actual transit operation in the U.S. and has been anticipated in future systems.

Inductors such as commutation reactors and motor current smoothing reactors, propulsion and braking current buses, and dynamic braking resistor banks are sources of pulsed magnetic flux which passes through the closed loop formed by the rails and axles of the car. Other electrical equipment on the car can produce stray flux as well. The induced rail-to-rail voltage  $V_R$  depends on the following factors:

- a. Position of car over the interconnection point and the position of various components underneath the car relative to that point;
- b. Mode of operation of the car;
- c. Specific spectral characteristics of the time-varying fluxes  $\phi_1(t)$  and  $\phi_2(t)$  due to the mode of propulsion control system operation, car speed, and train consist;
- d. Impedance characteristics of the two loops on opposite sides of the interconnection point;
- e. Frequency-dependent impedance characteristics of track circuit receiver input at the rail connection points.

#### 4.2 Equivalent Electrical Circuit

Figure 1-7(a&b) shows the equivalent electrical circuit which serves as the source of interfering signals. The impedances  $Z_1$  and  $Z_2$  account for the self-inductance of the rail-axle loops, series resistance of the axles, and rail-wheel contact resistances.

When a car axle is near the bond, the corresponding values of  $Z_1$  and  $Z_2$  approach the shunting impedance -- a very small value, typically. As can be seen from

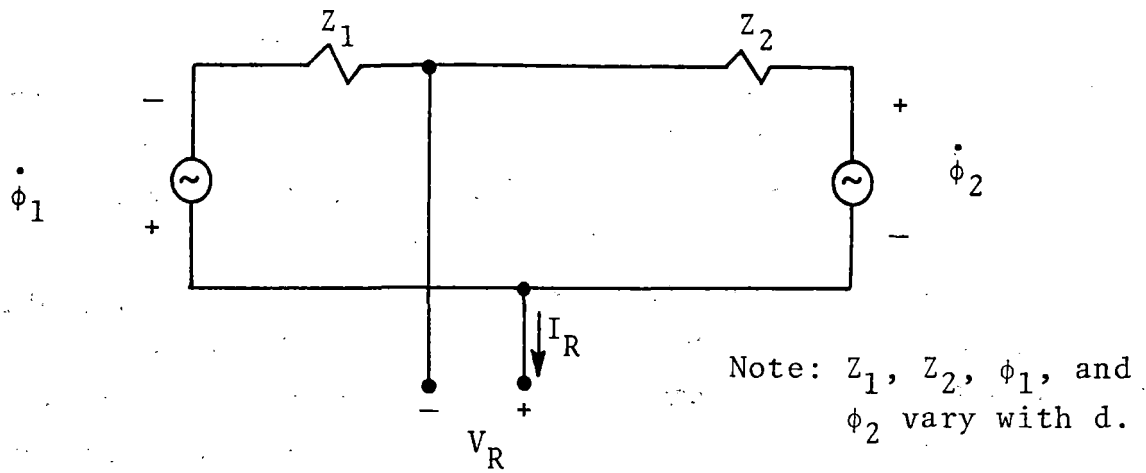

a) Loop equivalent

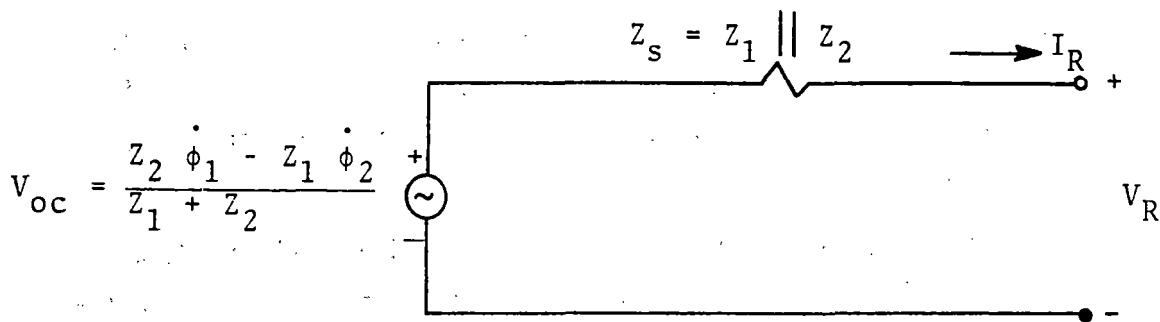

b) Thevenin Equivalent

FIGURE 1-7. EQUIVALENT ELECTRICAL CIRCUIT - INDUCTIVE EMISSION

Figure 1-7(b), the equivalent source voltage  $V_{OC}$  then becomes very small, since either  $\phi_1$  and  $Z_2$  are small, or vice versa. Since both fluxes  $\phi_1$  and  $\phi_2$  enter the expression for induced voltage, the peak-to-peak voltage swing will depend specifically upon the positioning, phase, direction, and polarity of various flux sources relative to the rail interconnection point at that time. A measurement of the voltage induced into the impedance bond under these conditions can be acquired using the monitoring circuit shown in Figure 1-8. Figure 1-9 shows a representative plot of the equivalent source impedance  $Z_s$  as a function of  $d$ , location of rail interconnection point under the vehicle.

Figure 1-10 shows typical waveforms of the rail-to-rail voltage recorded during the passage of a car using dc chopper control over a measurement site at one particular rapid transit system. The voltage waveform has a rather complex shape, arising as the sum of contributions from a number of magnetic components. Different portions of the waveform change polarity at different times, as the components causing them cross the bond position.

#### 4.3 Representative Observations of Inductive Interference

Figure 1-11 shows a complete spectral plot of the harmonic components of rail-to-rail voltage, obtained using an FFT analyzer. As a car passes an observation point, the rail-to-rail voltage changes in shape and amplitude, and thus spectral plots taken at different times show different characteristics. Note in Figure 1-11, however, that strong contributions only exist at the harmonics of the fundamental chopper frequency.

Figure 1-12(a&b) shows an accurately calibrated plot of rail-to-rail voltage at its maximum amplitude, as well as a plot of the time variation of the amplitude of a particular harmonic as a function of time during the passage of a four-car train. The rapid time variation of harmonic amplitude level is due to variation of chopper pulse width as the train accelerates, and the corresponding change in magnitude of the harmonic coefficients. Note that if the audio-frequency signaling system had a track frequency that was the same as or sufficiently close in value to a chopper harmonic frequency, and if the chopper harmonic in question reached sufficient amplitude, the track receiver could interpret a signal such as is pictured in Figure 1-12(b) as being a burst of coded track signal and could pick up the relay. This set of circumstances has been observed in fact in a number of instances.

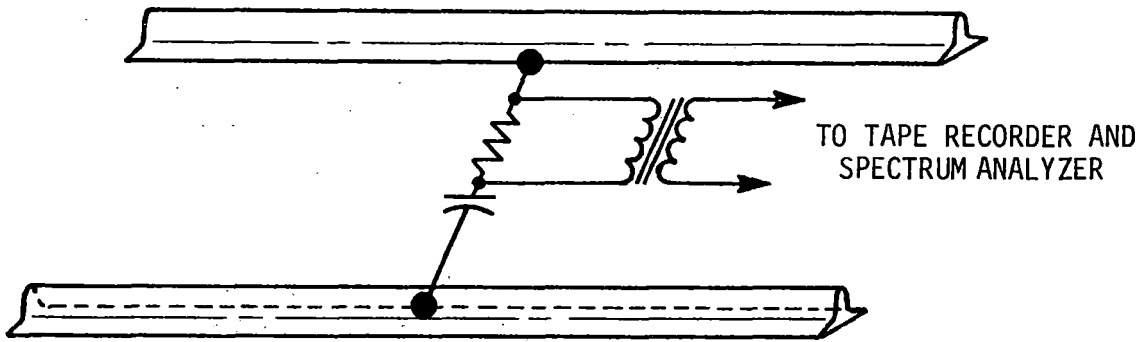

FIGURE 1-8. TRACK MONITORING CIRCUIT

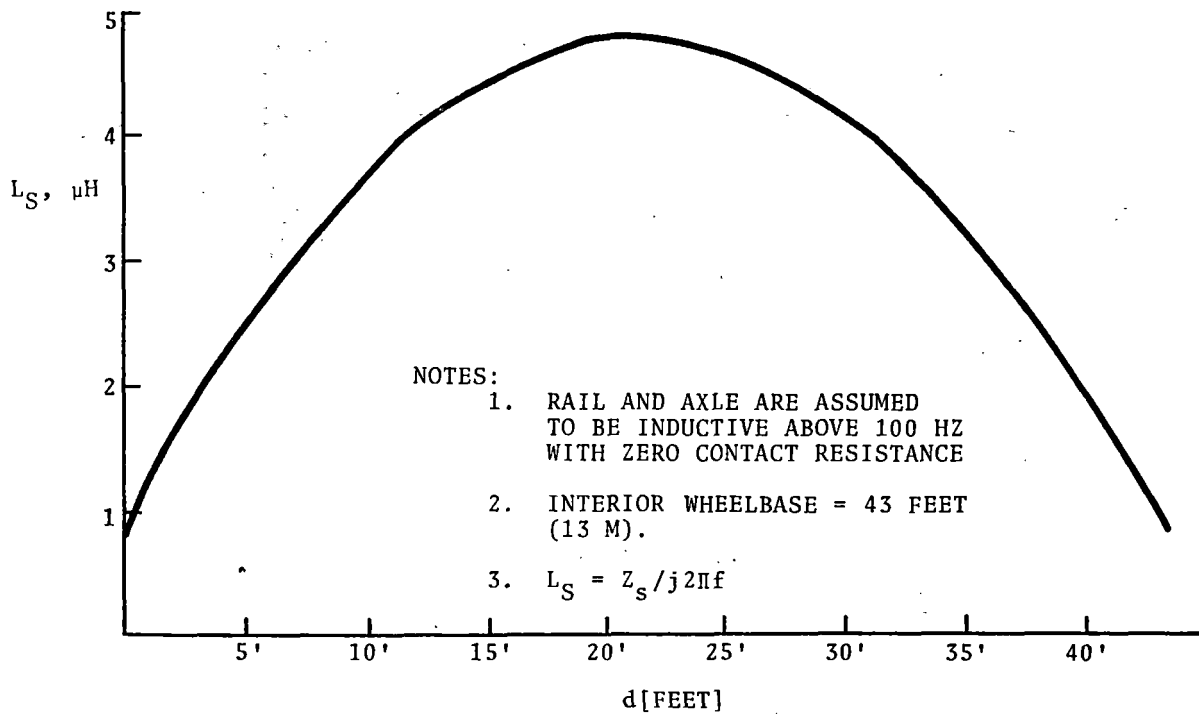
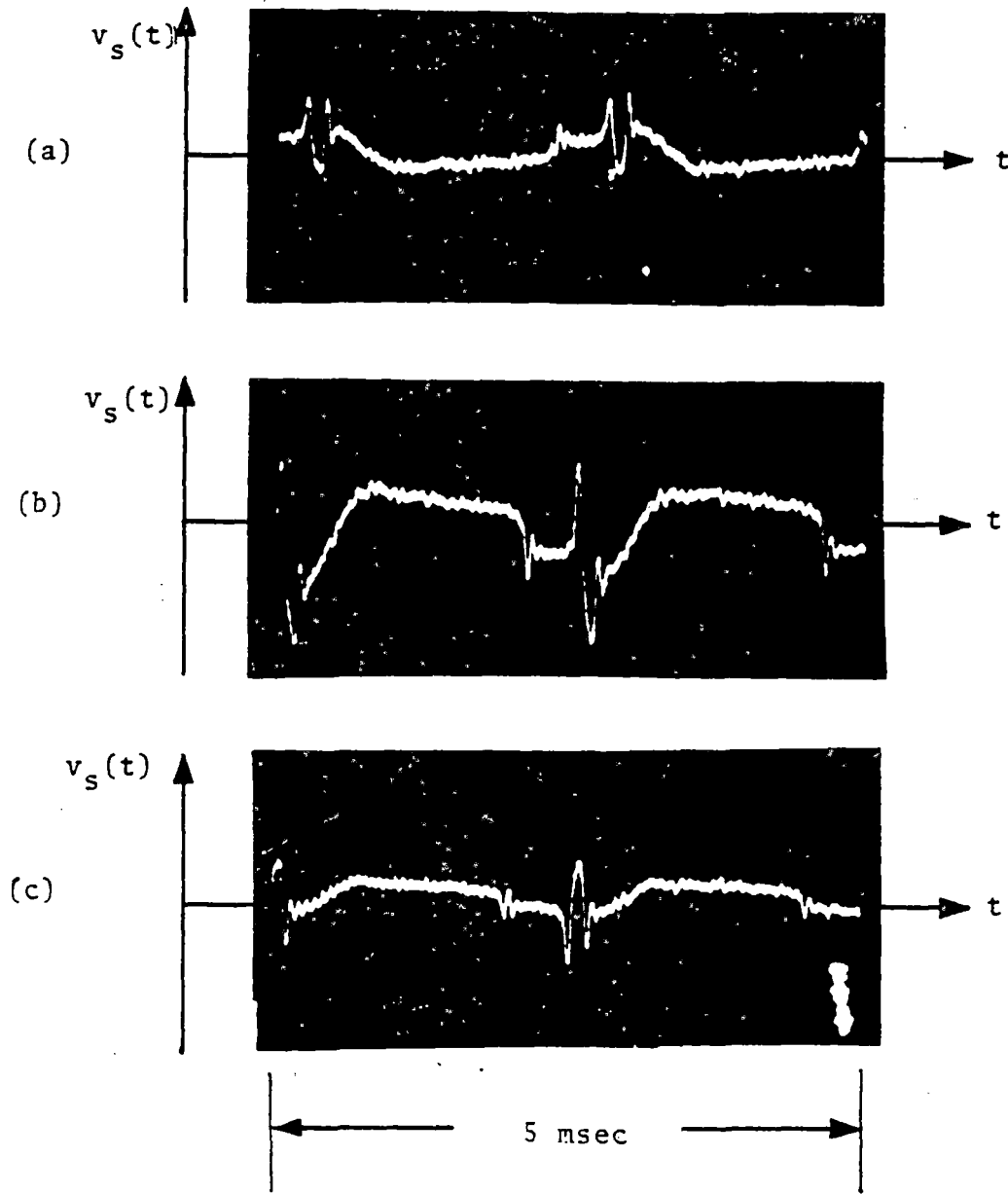

FIGURE 1-9. PLOT OF SOURCE INDUCTANCE VERSUS d



( $v_s(t)$ ) IS IN ARBITRARY UNITS.  
 UNITS ARE SAME FOR (a)-(c).)

FIGURE 1-10. RAIL-TO-RAIL VOLTAGE AT THREE DIFFERENT TIMES DURING PASSAGE OF MARTA CAR

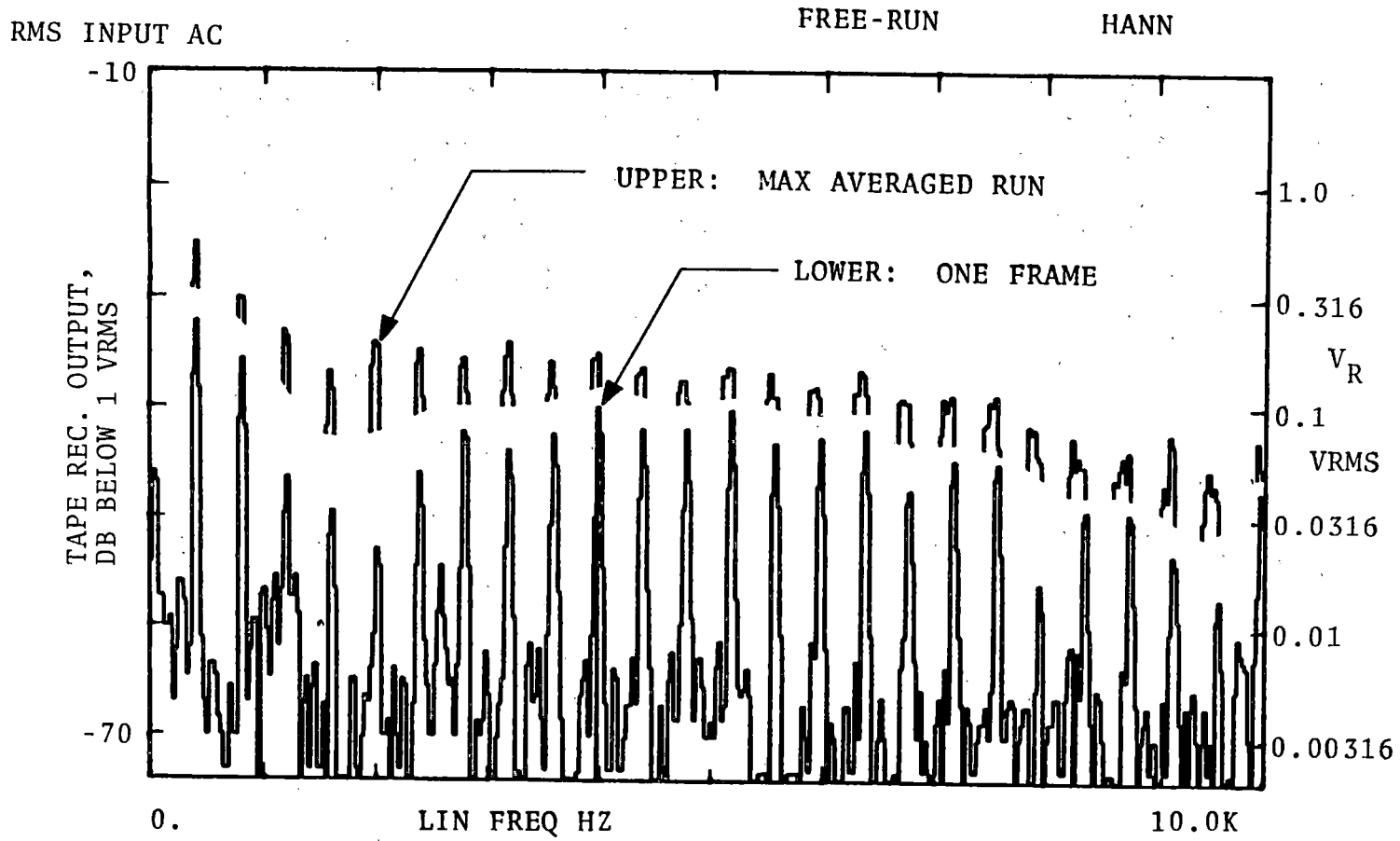
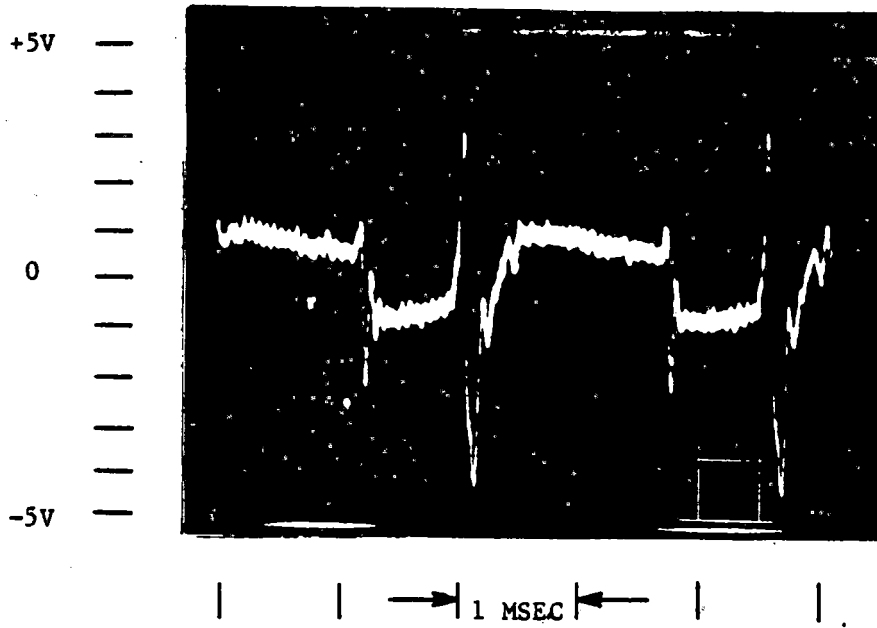
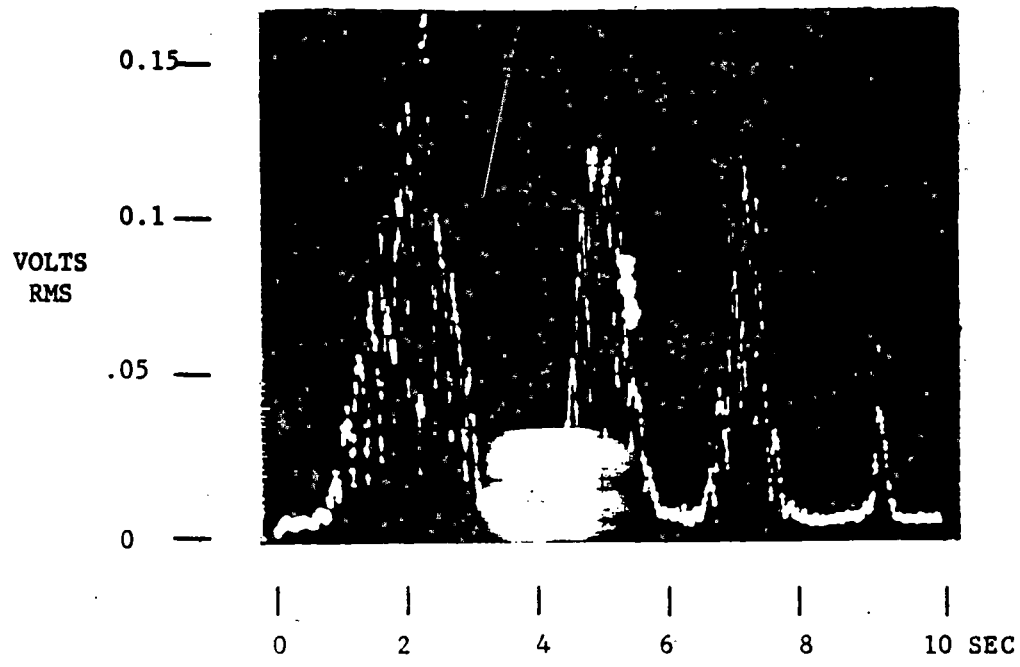

FIGURE 1-11. SPECTRUM OF RAIL-TO-RAIL VOLTAGE  $V_R$





a. RAIL-TO-RAIL VOLTAGE NEAR PEAK OF 1ST CAR



b. STRENGTH OF 9TH HARMONIC (3600 HZ) OF RAIL-TO-RAIL VOLTAGE AS TRAIN PASSES

FIGURE 1-12. MARTA RUN NO. 58 FULL POWER

## 5. CONCLUSIONS

At this time, inductive interference mechanisms are well understood. In addition to the extensive observations that have been made in the field under actual operating conditions, procedures now exist for observing interference levels in the laboratory for choppers and track circuits that are still in the engineering stage of development. Use of these procedures has proven beneficial in assuring compatibility of propulsion and signaling equipment for rapid transit systems currently under development.

## 6. REFERENCES

- 1-1 Holmstrom, F. Ross, "Inductive Interference in Rapid Transit Signaling Systems - Volume I: Theory and Background," U.S. Department of Transportation, Urban Mass Transportation Administration, Washington DC, May 1986, UMTA-MA-06-0153-85-7.
- 1-2 Holmstrom, F. Ross, "Inductive Interference in Rapid Transit Signaling Signaling Systems - Volume III: Data and Test Results," U.S. Department of Transportation, Urban Mass Transportation Administration, Washington DC, January 1986, UMTA-MA-06-0153-85-9.
- 1-3 West, Michael D., & F. Ross Holmstrom, "Laboratory and Field Testing of NYCTA Power Frequency Track Circuits," U.S. Department of Transportation, Urban Mass Transportation Administration, Washington, DC, February 1986, UMTA-MA-06-0153-85-12.
- 1-4 Holmstrom, F. Ross, "Conductive Interference in Rapid Transit Signaling Systems - Volume I: Theory and Data," U.S. Department of Transportation, Urban Mass Transportation Administration, Washington DC, November 1985 UMTA-MA-06-0153-85-6.
- 1-5 "Conductive Interference in Rapid Transit Signaling Systems - Volume II: Suggested Test Procedures," U.S. Department of Transportation, Urban Mass Transportation Administration, Washington DC, UMTA-MA-06-0153-85-6, to be published.

PART 2  
REPORT FORMATS, RECORDING AND  
DOCUMENTATION PROCEDURES

1. SCOPE

This section documents the formats and procedures used in formulating and applying these suggested test procedures.

2. FORMAT

The test method format shall be as specified in Table 2-1.

TABLE 2-1. TEST METHOD FORMAT

Title Format: TEST METHOD NO. DESCRIPTION/TITLE FREQUENCY RANGE

Sections:

1. PURPOSE
2. APPLICATION
3. TEST MEASUREMENT APPARATUS
4. TEST PROCEDURE
5. TABULATION OF RESULTS
6. NOTES

Test Method Numbering System

The test method numbering system shall be of the form RT/XXYYZ. The prefix RT denotes RAIL TRANSIT. Letters XX denote abbreviations for test method classifications as listed in Table 2-2 below. Numbers YY (01 to 99) indicate the number of a test of a particular classification. Suffix letter Z is a letter issued sequentially (i.e., A, B, C, ...) to denote a test of a specific number and classification, that has been adapted to an application involving specific equipment or requirements.

TABLE 2-2. TEST METHOD CLASSIFICATION

<u>METHOD XX</u>	<u>DESCRIPTION</u>
IS	Inductive Susceptibility
IE	Inductive Emissions
CS	Conductive Susceptibility
CE	Conductive Emissions
OC	Operating Characteristics

### 3. TEST REPORTING REQUIREMENTS

Integral to the performance of each test method is the documentation of testing scenarios and test results. Table 2-3 contains a sample test report format outlining report requirements.

TABLE 2-3. TEST REPORT REQUIREMENTS

1. Photo or Diagram of Test Configuration

2. Test Scenario

Significant Details Concerning the specific Tests to be conducted and Test Methods applied.

3. Measurement Equipment

a. Description, including manufacturer, model name and number, operating voltage and current, and frequency and voltage ranges used.

b. Serial number

c. Last Calibration Date

d. Transfer Characteristics and Calibration Factors for Measurement Sensors (i.e., probes, loops, antennas, etc.)

4. Measured Levels of Emission and/or Susceptibility for each Required Test Parameter and Condition

5. Graphs of Measured Data

6. Susceptibility Criteria

a. Circuits, Outputs, Displays to be monitored

b. Criteria for normal and degraded performance, and malfunction.

PART 3  
INDUCTIVE SUGGESTED TEST PROCEDURES

METHOD RT/ISO1A  
INDUCTIVE SUSCEPTIBILITY OF AUDIO-FREQUENCY RATE-CODED  
SIGNALING SYSTEMS FROM 300 Hz TO 10 kHz

1. PURPOSE

The purpose of this test is to determine the susceptibility of audio-frequency rate-coded track circuits to inductive interference voltage induced from rail-to-rail by the passage of a rail transit vehicle.

2. APPLICATION

This method is applicable to all audio-frequency track circuit equipment operating at frequencies between 300 Hz and 10 kHz in which the operating signal waveform consists of amplitude-modulated audio-frequency tones, modulated at a selectable discrete rate (i.e., code-rate). This test method has been applied, and an example of the results is presented in Appendix B.

3. APPARATUS

The test apparatus shall consist of the following:

- a. Amplitude-modulated audio-frequency signal generator, Wavetek Model 146 or equal.
- b. Audio-frequency power amplifier, Phase Linear Model 400 or equal, (See Note 6.2)
- c. Oscilloscope
- d. True RMS audio-frequency voltmeter.

#### 4. TEST PROCEDURE

The test shall be performed as specified herein. For inductive interference to be present the vehicle must pass over the point at which the track circuit receiver is electrically connected to the rails. Therefore, the test assumes that the track circuit is occupied (i.e., track circuit shunted between its transmitting end and receiving end).

##### 4.1 Verification of Nominal Track Circuit Operation

Verify that the track circuit receiver is working according to manufacturer's specifications, with the transmitter output impedance included in the circuit as required for proper impedance matching and with the transmitted track signal and/or reference signals supplied to receiver when required. Then set up the equipment as shown in Figure RT/IS01A-1. If the receiver has adjustable sensitivity, adjust the receiver to its most sensitive operating threshold.

##### 4.2 Inductive Susceptibility Test

###### 4.2.1 Testing at Initial Amplitude and Code Rate

Adjust the signal generator to sine wave output, 100 percent square-wave modulation, 0.1-Hz modulation rate (hereafter referred to as code rate), and carrier frequency equal to the nominal operating frequency  $f_0$  of the receiver under test. Adjust the signal level at the track terminals of the impedance bond to 0.5 Vrms during the on-portion of the signal (1.4 vp-p). (CAUTION - See Note 6.1.) Note which of the following response modes occurs:

- a. track relay remains down
- b. track relay momentarily picks up one or more times during each code rate cycle, and then drops
- c. track relay picks up and stays up continuously

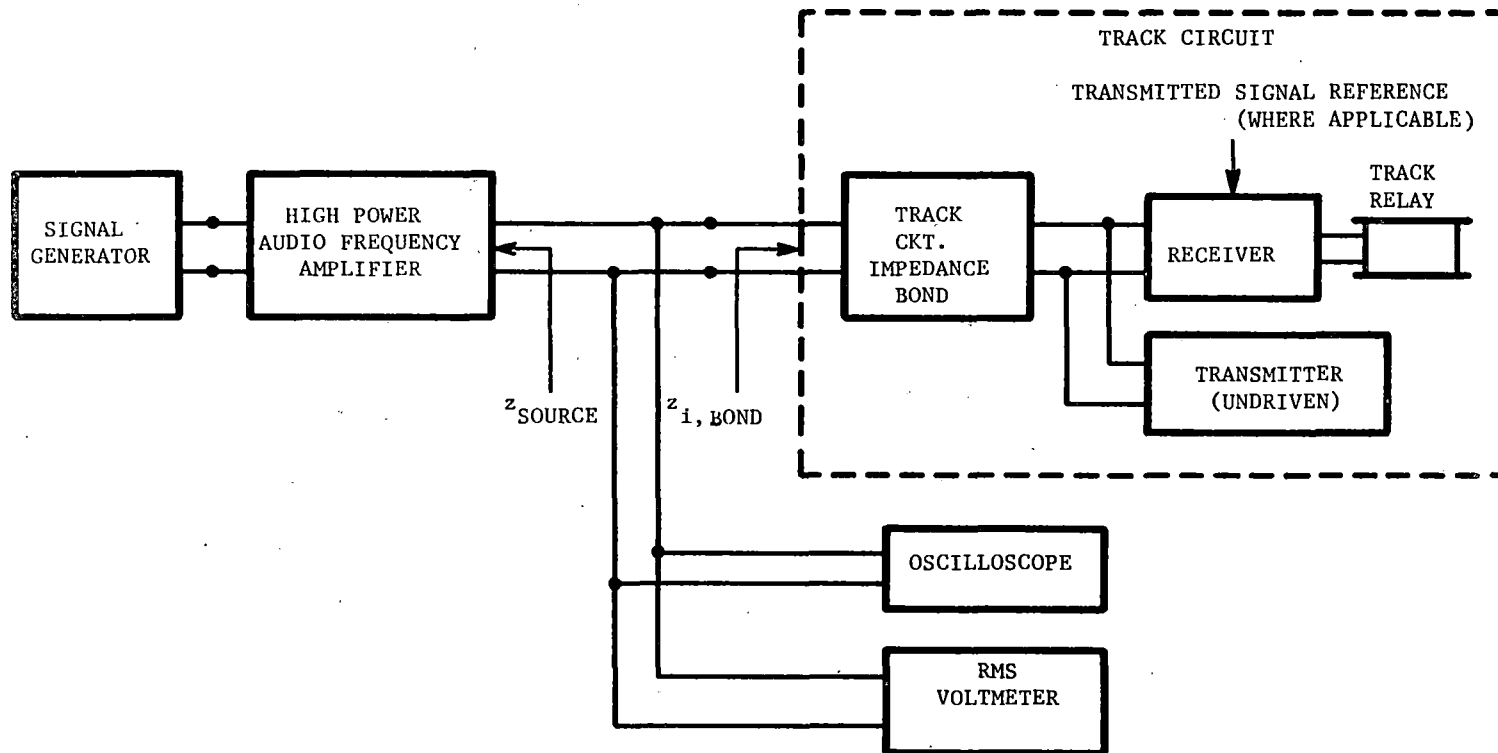

FIGURE RT/ISO1A-1. ARRANGEMENT OF TEST APPARATUS FOR PERFORMING MEASUREMENT OF INDUCTIVE SUSCEPTIBILITY OF SIGNALING SYSTEMS

Slowly increase the carrier frequency from  $f_0$  to 10 kHz, and then slowly decrease the carrier frequency from  $f_0$  to 300 Hz. Determine to the nearest 5 Hz the frequencies at which response mode changes. Tabulate the various frequency intervals between 300 Hz and 10 kHz in which the different response modes occur. Care must be taken to maintain constant bond input amplitude as frequency is detuned from  $f_0$ .

#### 4.2.2 Testing at Other Signal Amplitudes

Change the signal amplitude at track terminals of the impedance bond to 0.25 Vrms (half of 0.5 Vrms), and repeat 4.2.1. Repeat 4.2.1 at each of the following signal levels given in Vrms: 0.125, 0.0625, 0.0313, 0.0156. If response mode (b) or (c) occurs for any frequency in the 300 Hz to 10 kHz range at the 0.0156 vrms signal level, continue by repeating 4.2.1 at successive signal levels that are half the previous level, until a level is reached at which response mode (a) is observed for all frequencies in the 300 Hz to 10 kHz range. (The signal levels used above correspond to -6 dBV, -12 dBV, -18 dBV, etc.)

#### 4.2.3 Testing at Other Code Rates

Change the code rate to 0.2 Hz, and repeat 4.2.1 to 4.2.2. Repeat 4.2.1 to 4.2.2 again at each of the following code rates given in Hz: 0.5, 1.0, 2.0, 5.0, 10, 20, 50. If, after having increased the code rate to 50 Hz, response modes other than (a) are occurring for any frequency between 300 Hz and 10 kHz and any of the specified signal levels, continue increasing the code rates using decade multiples until only response mode (a) occurs. When a code rate is reached at which only response (a) occurs, note the previously used code rate. Repeat 4.2.1 to 4.2.2 at code rates that are 1.25, 1.5, 1.75, etc., times the previously used code rate. Stop when a code rate is reached at which only response (a) occurs.



## 5. TABULATION OF RESULTS

Tabulate data on a data sheet or sheets as shown in Figure RT/IS01A-2.

## 6. NOTES

### 6.1 Maximum Allowable Signal Levels

When performing the tests in 4.2, do not exceed manufacturer's stated maximum allowable signal level in any frequency range. Modify test procedures as required to stay within allowable signal levels.

### 6.2 AM Test Duty Cycle

The test procedure described in 4.2 -- Amplitude Modulation Test -- has been specified with square-wave modulation (50 percent duty cycle). This test does not include measurement of receiver sensitivity as a function of duty cycle. If duty cycle is believed to be an important parameter, the entire test procedure may be performed using duty cycles other than 50 percent as well.

### 6.3 Audio Amplifier Output Impedance

Ordinarily, when driving the track circuit impedance bond with a signal that has the prescribed voltage waveform, a signal source with very low output impedance should be used. However, the tests specified in 4.2 use signals of sufficiently narrow bandwidth that acceptable results can be obtained using a signal source with higher output impedance, such as the 4-ohm output taps of an audio power amplifier. The narrow bandwidth of the applied signal assures that the gain reduction factor due to impedance match,  $(Z_{i,bond}/Z_{source})$ , is approximately constant over the entire signal bandwidth, for any fixed carrier frequency. Furthermore, since the receiver filter bandwidth typically is much narrower than the impedance peak of the impedance bond near the nominal receiver frequency, there generally will not be an appreciable variation in  $V_I$  across the bandwidth of the receiver filter.

SYSTEM TESTED: \_\_\_\_\_ FIELD LOCATION: \_\_\_\_\_  
 TEST PERFORMED: \_\_\_\_\_ BY WHOM: \_\_\_\_\_  
 DATE: \_\_\_\_\_ OPERATING FREQUENCY:  $f_o =$  \_\_\_\_\_  
 $V_I =$  INTERFERENCE LEVEL IN mV RMS

$V_I$	CODE RATE - HZ														
500															
250															
125															
62.5															
31.3															
15.6															

FREQUENCY - HZ

—: NO-PICK OF RELAY  
 \*: MOMENTARY PICK OF RELAY  
 N: RELAY PICKS IN NARROW RANGE OF FREQUENCIES NEAR THIS VALUE

FIGURE RT/IS01A-2. SAMPLE DATA SHEET

3-6

METHOD RT/IE01A  
INDUCTIVE EMISSIONS OF VEHICULAR ELECTRICAL POWER SUBSYSTEM,  
RAIL-TO-RAIL VOLTAGE FROM 20 Hz TO 20 kHz

### 1. PURPOSE

This method is used for measuring amplitudes of the harmonic components of interference voltage from 20 Hz to 20 kHz, measured from rail to rail during the passage of a rail transit vehicle.

### 2. APPLICABILITY

The test is intended primarily for rail transit vehicles equipped with solid-state propulsion control systems (e.g., choppers or ac drives), but may be performed for other types of rail transit vehicles as well, where applicable. Inductive interference is caused by the time-varying magnetic flux lines emanating from propulsion equipment and other electrical equipment on the vehicle passing through the rail-axle loop under the vehicle. Its presence is evidenced by the observation of abnormally high levels of rail-to-rail voltage observed at locations under the vehicle. The passage of a vehicle over a fixed location induces a transient interference voltage from rail to rail, the harmonics of which can have measurable amplitude throughout the audio-frequency spectrum. The induced voltages can be coupled into track circuit apparatus and disrupt the normal operation of such equipment. The procedure described below has been applied successfully and an example of the results is presented in Appendix B.

### 3. APPARATUS

Test apparatus shall consist of the following:

- a. GenRad Model 2512 Spectrum Analyzer, or equal (FFT spectrum analyzer capable of real-time spectral analysis at 20 kHz, with 400 evenly spaced frequency increments from 0 Hz to maximum of range used).
- b. Oscilloscope camera for spectrum analyzer (optional).

- c. Tape recorder, Brüel and Kjær Model 7005 with Direct Record Unit ZE-0299, or equivalent (IRIG Intermediate Band, Direct Record, 15 in/sec, with at least two channels).
- d. X-Y plotter, Esterline - Angus Model XY575, or equal, compatible with FFT analyzer.
- e. Audio-frequency signal generator.
- f. True RMS voltmeter.
- g. Track coupling network consisting of 1:1 isolation transformer (UTC Model LS-33 200 ohm/200 ohm, or equal); 4  $\mu$ f-1500 v capacitor; and 220 ohm, 2 watt resistor; or other suitable means for assuring dc isolation.
- h. Rail clamps.

#### 4. TEST SETUP AND PROCEDURE

##### 4.1 Test Setup for Data Collection

The test set-up for data collection shall be as shown in Figure RT/IE01A-1.

##### 4.2 Procedure for Data Collection

This procedure shall be performed for each different operating mode of the rail transit vehicle, e.g., each different propulsion setting, and each different brake rate that the vehicle can be operated in, with the objective of obtaining worst-case data.

##### 4.2.1 Initial Preparation of the Spectrum Analyzer

Select the "max. Hold" averaging mode, the Hann windowing mode, 10 db/division display, 0 dbv sensitivity, and linear frequency scale. Select the appropriate frequency range.

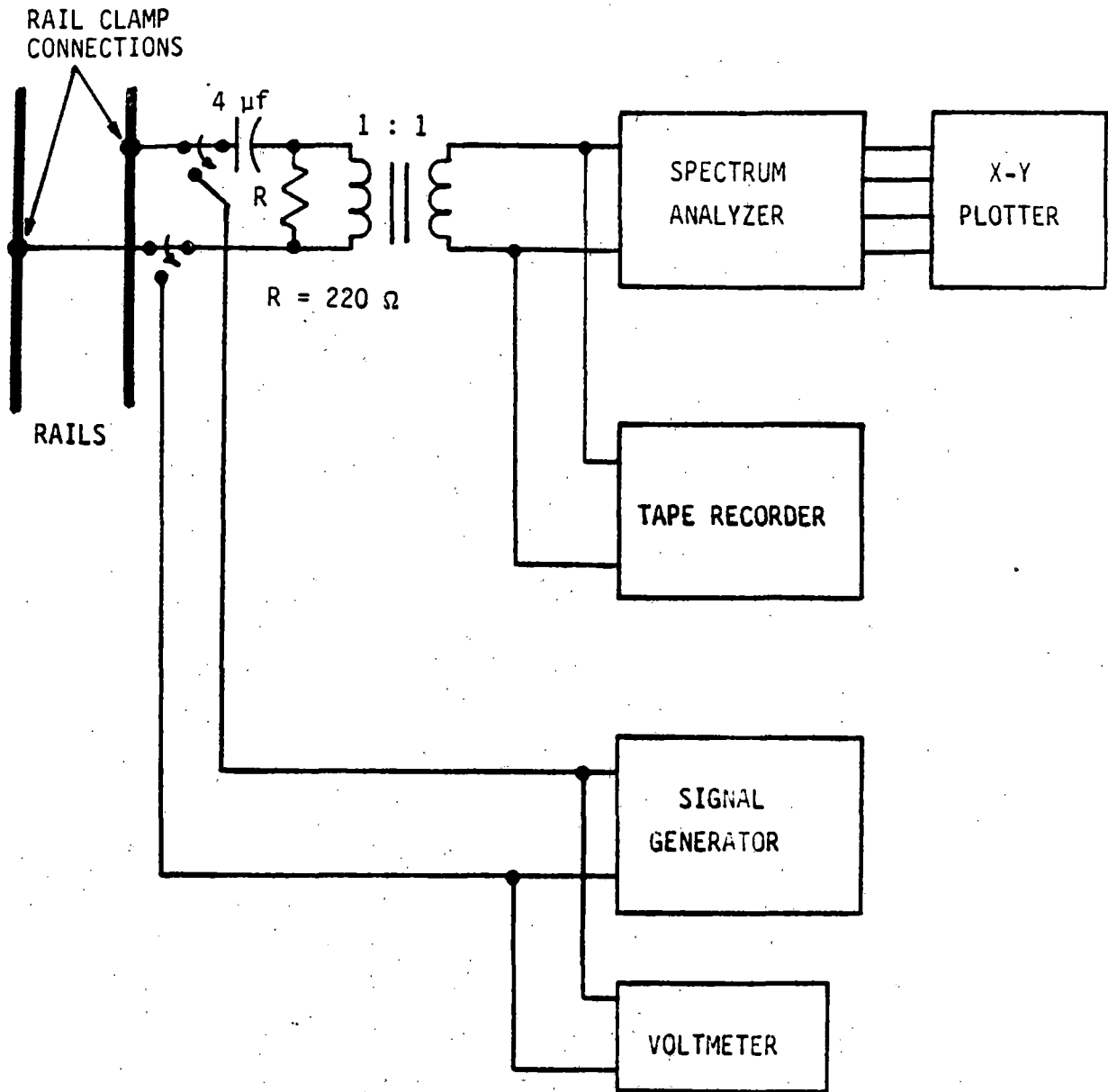

FIGURE RT/IE01A-1. TEST SETUP FOR DATA COLLECTION

#### 4.2.2 Calibration

Perform a calibration sweep covering the frequency range of interest as follows: Set up the equipment as shown in Figure RT/IE01A-1, but attach the rail clamp connections to the output of the audio-frequency signal generator rather than to the rails. Adjust the spectrum analyzer as noted in 4.2.1. Tape-record the signal into the spectrum analyzer. Using a fixed signal amplitude in the range of expected signal levels, step the frequency across the entire frequency range of interest. Each step must be of sufficient duration for the corresponding amplitude displayed on the spectrum analyzer to reach a steady final value. Make an X-Y plot of the final spectrum analyzer display. Note on the plot the signal amplitude, expressed in dbv, displayed on the spectrum analyzer at each frequency step. This amplitude is defined as  $X_{0db}(f)$ . Calculate the dbv value of the audio-frequency signal generator output, defined as  $X_{1db}$ . Then calculate, tabulate, and graph the instrumentation transfer function  $H_{db}(f) = X_{0db}(f) - X_{1db}$ . Values of  $H_{db}(f)$  may be either greater than or less than 0. This transfer function characterizes the behavior of the system comprised of the track coupling circuit and spectrum analyzer.

Some spectrum analyzers, including the one specified herein (Item 3.0-a), do not correct automatically for the reduction in displayed amplitude occurring from use of the Hann window. In that event, the values of  $H_{db}(f)$  determined above will include a term of -1.8 db amplitude due to Hann windowing. For other spectrum analyzers, refer to the value of Hann window correction factor stated by the manufacturer.

#### 4.2.3 Performance of Test

With rail clamps attached to the rails, turn on the tape recorder, activate the spectrum analyzer, and have the vehicle run past the observation point. When the vehicle is clear of the observation point, store the spectrum analyzer display.

NOTE: If the spectrum analyzer's input signal overdrive indicator remained off during the passage of the vehicle, the data are valid. If the input signal overdrive indicator flashed or remained on during the vehicle's passage, change the sensitivity setting to +10 dbv and repeat 4.2.3. If overdrive indicator fails to remain off, change sensitivity setting to +20 dbv and repeat 4.2.3. If further densensitization is required, change transformer taps to achieve the required voltage reduction, and repeat 4.2.1-4.2.3. Use the voice channel of the tape recorder to record salient operating characteristics of the run, e.g., starting point or stopping point of train, propulsion or braking mode, and speed when the front of train reaches observation point.

#### 4.2.4 Field Reduction of Data

With the display stored in the spectrum analyzer, move the frequency cursor across the spectrum analyzer screen and record the displayed dbv amplitudes of the peak values of harmonic components. If convenient, plot the spectrum analyzer display using the X-Y plotter. (It is recommended that X-Y plots be made in the field of some if not all runs, for later use in the lab in validating tape-recorded data.) Optionally, photograph the spectrum analyzer display. Using data from the graph of  $H_{db}(f)$  from 4.2.2, subtract the corresponding values of  $H_{db}(f)$  from displayed amplitude at each harmonic, to obtain the actual rail-to-rail dbv amplitude of each harmonic.

#### 4.2.5 Test Repetition

Repeat 4.2.3 and 4.2.4 for each acceleration and braking mode. If a one-car train is used, multiple runs in each mode will be required to obtain data for the train passing the measuring point at a variety of speeds.

### 4.3 Laboratory Reduction of Data

4.3.1 Test Setup - The test setup shall be as shown in Figure RT/IE01A-2.

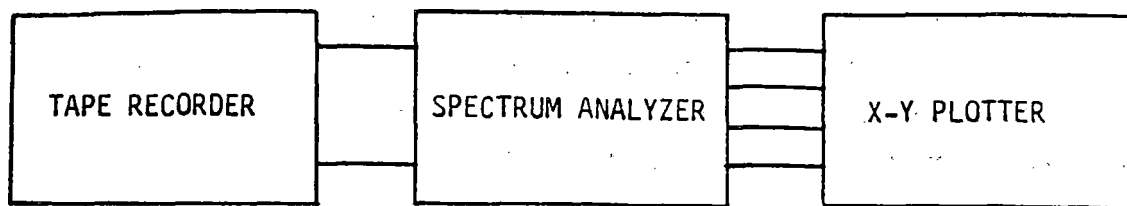

FIGURE RT/IE01A-2. TEST SETUP FOR LAB REDUCTION OF DATA

#### 4.3.2 Calibration

Adjust the spectrum analyzer as noted in 4.2.1. Play back the calibration signals recorded in 4.2.2 into the spectrum analyzer. Using the tape recorder output as the stepped frequency source, repeat the remaining steps of 4.2.2, to obtain data for the overall instrumentation transfer function in both graphical and tabulated form, defined as  $H'_{db}(f)$ . This overall instrumentation transfer function will include characteristics of the track coupling network and spectrum analyzer as did  $H_{db}(f)$ , and in addition those of the tape recorder.

#### 4.3.3 Data Reduction

Adjust the spectrum analyzer as described in 4.2.1. Play back the recorded interference signals into the spectrum analyzer, following procedures outlined in 4.2.3. Generate X-Y plots of displayed data as outlined in 4.2.4. To calculate the actual rail-to-rail dbv amplitude of each harmonic, subtract the corresponding value of  $H'_{db}(F)$  from each displayed harmonic amplitude. Compare the results of field data reduction and laboratory data reduction to verify the validity of the tape recorded data.



## 5. TABULATION OF RESULTS

### 5.1 Index of Runs

An index shall be prepared, giving pertinent information of each run, with runs numbered consecutively.

### 5.2 Tape Recordings

The tape recording shall be stored for future use and analysis, along with a written index of its contents, in the form of tape distance indications for various runs. The tape recorder used to make recordings shall be noted by make, model, and serial number.

### 5.3 Spectrum Analyzer X-Y Plots

X-Y plots of spectrum analyzer displays generated in the field according to 4.2.4 and in the lab according to 4.3.3 shall be numbered by run and stored in a permanent manner.

### 5.4 Spectrum Analyzer Photographs

Spectrum analyzer photographs taken in the field as noted in 4.2.4 shall be numbered by run and stored in a permanent manner.

## 6. NOTES

### 6.1 Recorded Rail-to-Rail Voltage

The recorded rail-to-rail voltage is equivalent to an open-circuit source voltage, and is the Thevenin equivalent source voltage of the rail-axle loop. The Thevenin equivalent source impedance of this loop is formed by the impedances of the rails, wheels, and axles. Observation of this voltage does not account for a voltage drop that would occur if actual track circuitry were connected between the rails. Such connection would allow current to flow through the source impedance and track circuit impedance in series, resulting in voltage division. The resulting voltage drop can be significant, depending on the relative values of track circuit impedance and source impedance.

## 6.2 Alternate Track Coupling Circuits

The track coupling circuit shown in Figure RT/IE01A-1, consisting of a  $4\ \mu\text{f}$  capacitor, 220 ohm resistor, and transformer, acts as a high-pass filter with a lower cutoff frequency of approximately 180 Hz, with response below that frequency falling off at a rate of 6 db per octave. To achieve better response at lower frequencies, the value of capacitance may be increased. As an alternative to the R-C-transformer circuit, other active or passive coupling circuits may be used if: a) they possess adequate frequency response characteristics in the frequency ranges of interest, and b) they provide an acceptable level of dc isolation of the electronic instrumentation from the running rails.

## 6.3 Alternate Tape Recorder Operation

Direct-record tape recording is a band-pass process, with both lower and upper cutoff frequencies. Many tape recorders do not possess a low enough lower cutoff frequency to accurately record signals at the lower power frequencies used in signaling. When interfering signals must be recorded at such frequencies, and direct-record tape recording does not provide adequate low-frequency response, fm recording may be employed.

## 6.4 Rail Clamp Connection Points

When assessing levels of inductive emissions that would be coupled into audio-frequency track receivers connected to continuously welded rail with no insulated joints, the rail clamps must be connected rail-to-rail at a point at least one interior wheelbase away from the nearest rail joint. When assessing levels of inductive emissions that would be coupled into power-frequency track receivers connected to rails using insulated joints for block-to-block isolation, the rail clamps must be connected rail-to-rail at a point directly adjacent to a single insulated joint or pair of insulated joints. In this case, the next insulated joint must be at least one interior wheelbase away.

## 6.5 Applicability to Measurement of Conductive Emissions

The measurement procedures outlined herein also may be applied to measure amplitudes of open-circuit rail-to-rail voltage due to conductive interference. For this purpose, instead of operating the train over the measuring point as stated in paragraph 4.2.3, the train must be operated away from the measuring point, either in the same track circuit for the track circuit occupied case, or in an adjacent track circuit for the track circuit unoccupied case. Due to the nature of impedances of the circuit comprised of third rail, running rails, and track circuit components, extreme caution must be exercised in extrapolating the results of such measurements to predict worst-case conductive interference levels.

## METHOD RT/IE04A

### INDUCTIVE EMISSIONS OF VEHICULAR ELECTRICAL POWER SUBSYSTEM, EMULATED TRACK CIRCUIT

#### 1. PURPOSE

The purpose of this test is to reproduce inductive emissions of transit vehicle electrical power equipment in the laboratory under emulated track circuit conditions.

#### 2. APPLICABILITY

This test is applicable to all electric power equipment used on transit vehicles which utilize steel wheels and steel rails for guidance, signaling, and train control. The passage of a vehicle over a fixed location may induce a transient rail-to-rail interference voltage, the harmonics of which can have measurable amplitude throughout the audio-frequency spectrum. The induced voltages can be coupled into the track circuit signaling apparatus and disrupt the normal operation of such equipment. Three test conditions are possible:

TEST CONDITION A - with simulated in-band resistance of the track circuit impedance bond

TEST CONDITION B - with actual signaling equipment

TEST CONDITION C - recorded open-circuit voltage of the rail-axle loop, i.e., the Thevenin equivalent source voltage as per Figure 1-7

Unless otherwise specified, TEST CONDITION A shall apply, and this procedure details that test condition. Test conditions A, B and C have been applied and an example of the test results for TEST CONDITION A is presented in Appendix B.

#### 3. APPARATUS

The following equipment is required:

- a. A complete operating set of vehicular electrical equipment suspected of producing inductive emissions.
- b. Aluminum tubing, grade 6061-T6 or similar, 95 mm (3.75 inches) outside diameter and 0.89 mm (0.35 inch) minimum wall thickness (see Note 6.4 for modifications), and length equal to the interior wheelbase of the car (see Note 6.5 for modification). The tubing is used to simulate running rail.
- c. Aluminum tubing, grade 6061-T6 or similar, 15.9 mm (0.625 inch) outside diameter and 0.89 mm (0.035 inch) wall thickness, or equivalent conductor. This conductor is used to simulate the vehicle axle reactance.
- d. A specified resistor  $R_B$  to simulate the in-band resistance of the track circuit impedance bond.
- e. Copper wire, AWG No. 6 or heavier, to connect the resistor  $R_B$  (item 3.0. d) to the test apparatus.
- f. FFT real time spectrum analyzer, GEN RAD model 2512 or equivalent.
- g. X-Y plotter compatible with spectrum analyzer (Esterline-Angus Model XY575, or equivalent).
- h. A specified resistor  $R_A$  to simulate rolling axle resistance. The resistance shall not be greater than is specified for track signal shunting. If unspecified, the  $R_A$  shall be 0.12 ohms (noninductive), 2 watts.
- i. Strip-chart recorder and adjunct instrumentation as required to record essential operating parameters of propulsion equipment.
- j. Tape recorder (optional), Brüel and Kjær Model 7005 with Direct Record Unit ZE-0299; or equivalent (IRIG, intermediate band, direct-record, 15 in/sec).
- k. Wayside Track Circuit Signalling Equipment (TEST CONDITION B).

## 4. TEST PROCEDURE

### 4.1 Test Setup

The apparatus shall be set up in accordance with Figure RT/IE04A-1. The arrangement of vehicle equipment shall conform as closely as possible to the undercar configuration. Traction motors may be located remotely (see Note 6.5). The tubes used to emulate the running rails shall be marked in equal increments 0.4 meters apart, and the increment boundaries marked in numerical sequence 0, 1, 2, 3, etc., starting at one axle. These are called bond positions.

### 4.2 Calibration

A calibration sweep covering the frequency range of interest should be performed. Using a fixed signal amplitude in the range of expected signal levels, the frequency sweep should be recorded on tape for use in later data reduction and analysis. Additionally,

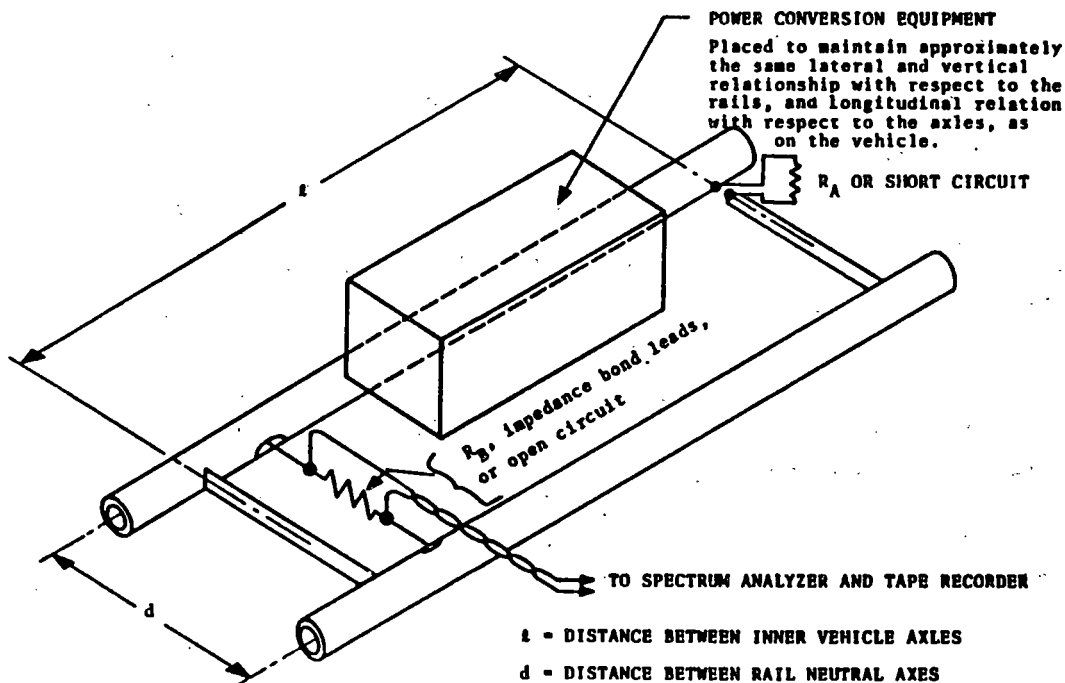

FIGURE RT/IE04A-1. TEST SETUP

the sweep should be captured on the spectrum analyzer, plotted and fully annotated. This provides characterization of instrumentation throughput for the entire measurement configuration.

Some spectrum analyzers, including the one specified herein (Item 3.0 f), do not automatically correct for the amplitude reduction associated with Hann windowing. In that event, the data as displayed by the spectrum analyzer shall be adjusted by adding +1.8 dB, to obtain actual levels. This correction must be made especially to correlate level of injected reference signal with its amplitude measured with spectrum analyzer.

#### 4.3 Testing with Zero Added Axle Resistance

Starting with resistor  $R_B$  in position 1, and resistor  $R_A$  replaced by a short circuit, the propulsion equipment shall be exercised through all its operating modes (e.g., acceleration, dynamic, and regenerative braking), under predetermined worst case conditions (usually maximum dc propulsion line voltage and maximum propulsion current). Nonpropulsion equipment shall also be operated under worst case conditions, if possible. The spectrum analyzer shall be operated in peak holding (maximum) and hanning timewindowing modes. The spectrum analyzer shall acquire data throughout each operating cycle, and the cumulative spectrum shall be photographed and plotted (see Note 6.3). This sequence shall be repeated at alternate (odd numbered) bond positions, except in the neighborhood of response maxima, where data shall be obtained at all bond positions as well as at intermediate positions if needed. As the test progresses, a graph of the greatest amplitude of any spectral line in the signaling band versus bond position shall be generated.

At maximum response, and last bond position, the following system parameters shall be recorded on the strip chart:

- input filter capacitor bank voltage
- propulsion system input current
- traction motor current

- field supply current (if separately excited)
- vehicle speed
- pertinent parameters of the auxiliaries (if included)

#### 4.4 Testing With Added Axle Resistance

The test shall be repeated with the specified axle resistance  $R_A$  inserted first at one axle and then at the other axle.

#### 4.5 Testing Auxiliaries Only

If applicable, the procedure shall be repeated with auxiliaries only (propulsion off) to obtain emission signature of a stationary vehicle.

### 5. TABULATION OF RESULTS

The tabulation of results for these tests shall include the following:

- a. all spectral plots fully annotated
- b. tabulated harmonic amplitudes (where spectral plots are not made)
- c. annotated strip charts of the propulsion system parameters
- d. test equipment identification, serial numbers, and certification information

### 6. NOTES

#### 6.1 Tape Recorder

In the event that a tape recorder is used for recording data for later analysis, the tape recorder initially shall be set up according to the procedures outlined in METHOD RT/IE01A, Sections 4.2.1, 4.2.2, and 6.3. Recorded tapes shall be documented as set forth in METHOD RT/IE01A, Section 5.2.



## 6.2 Spectral Plotting

Spectral plotting is time-consuming and usually is not required at each position because the character of the spectrum changes only as the bond comes under the influence of different major flux sources. Experience has shown that all the needed information can be obtained by making spectral plots at a few representative positions, and by reading and recording the following data directly with the aid of the cursor at each position:

- a. frequency and amplitude of the spectral line nearest the low-frequency end of the signaling band
- b. frequency and amplitude of the spectral line nearest the high-frequency end of the signaling band
- c. frequency and amplitude of the maximum-amplitude spectral line in the signaling band

## 6.3 Tubing

Although 3.75 inch diameter tubing allows a formally correct simulation of the running rails, experience has shown that tubing as small as 1 inch OD can be used under appropriate circumstances. The rationale for this approach, together with an example, are given in RT/IE04A-Exhibit A.

## 6.4 Reduced Loop Length

A loop of tubing whose length is equal to the interior wheel-base of the car may be unwieldy under cramped laboratory conditions. It has been found that a shorter loop provides essentially unchanged results, provided the loop is sufficiently long to capture essentially all of the magnetic flux that would be captured by a full-length loop. Since a shorter loop has lower inductance than a longer loop, at times it may be desirable to compensate for this lower inductance by adding lumped series inductances to the ends of the loop. A few turns of heavy copper wire wound on a nonconducting mandrel of approximately 1.5 inch diameter generally are sufficient.

## 6.5 Traction Motors

To date, traction motors have not been observed to produce inductive interference in track circuits. However, if they are suspected of being a significant source of induction into the rails, they must be tested separately under conditions that appropriately emulate the motor-truck-track circuit relationship.

## 6.6 Track Circuit Impedance

The recorded results of TEST CONDITION A serve as an indication of interference voltage levels that occur within the passband of a track receiver filter. Track circuit impedance bonds generally are tuned to resonance at or very near receiver frequencies. The bandwidth of the resonance peak in bond input impedance is typically greater than the bandwidth of the receiver filter. Therefore, across the passband of the track receiver filter, the input impedance to the track terminals of the impedance bond typically will be approximately constant and resistive. The value of this resistance is typically a few tenths of an ohm.

## 6.7 Test Condition B

TEST CONDITION B provides the most accurate modeling possible in the lab of the effects of inductive interference on track circuitry. During the conduct of tests using TEST CONDITION B, the actual response of track circuit receivers can be observed and recorded. The dynamic response of the track circuit receiver can be observed as the carborne power equipment is cycled through various operational modes.

## 6.8 Test Condition C

TEST CONDITION C provides the most general measure of inductive interference voltage, since it directly measures  $V_{OC}$ , the Thevenin-equivalent open-circuit

voltage of the circuit that serves as the source of inductive interference to the track circuitry. This knowledge can be used in conjunction with wheel-axle, rail, and bond input impedances to calculate levels of inductive interference in track circuits under arbitrary conditions.

#### 6.9 Emulation of Jointless Track Circuits vs. Track Circuits Employing Insulated Joints

To emulate circuit conditions prevailing when insulated joints are used to delineate track circuits, resistor  $R_A$  in Figure RT/IE04A-1 must be replaced by an open circuit. To emulate circuit conditions prevailing when track circuit receiver leads are attached to continuously welded rail and insulated joints are not used to delineate track circuits, resistor  $R_A$  should be replaced by a short circuit; or a resistance value should be used that simulates rolling axle resistance as noted in paragraph 3h.

#### 6.10 Static Test Conditions

Note that this test method is a static laboratory test insofar as the effects of car motion on observed rail-to-rail voltages as a function of time cannot be observed.

## METHOD RT/IE04A

### EXHIBIT A - SIMULATION OF RAIL-WHEEL-AXLE IMPEDANCE

1. The electrical characteristics of the rail-wheel-axle loop under a rail car can be simulated accurately by use of aluminum tubing, since at audio-frequencies the loop impedance is largely inductive. Furthermore, the inductance is approximately constant across the range of track circuit signaling frequencies due to the fact that skin effect prevents fields from penetrating into the interior of conductors, yielding essentially equal inductive characteristics for solid steel and tubular aluminum conductors. This exhibit outlines the electrical characteristics of actual and simulated rail-wheel-axle loops.

#### 2. AXLE IMPEDANCE

Axle impedance is nearly all inductive, with inductance lying in the range of 1.2 to 1.8  $\mu\text{h}$  at audio-frequencies. Skin effect causes inductance to decrease as frequency increases. Aluminum tubing can be used to simulate this inductance.

The inductance of a straight nonmagnetic tubular conductor is given by the relation:

$$L_A = 0.2 \left[ \log_e(2\ell/r) - 1 + \alpha \right] \mu\text{h/meter}$$

where  $\ell$  is length,  $r$  is outer radius, and  $\alpha$  is a function of ID/OD ratio and skin depth. The parameter  $\alpha$  is approximately zero for a thin shell or for zero skin depth, and approximately 0.25 for a solid conductor whose radius is much less than skin depth.

An aluminum tube with 1.59 cm (0.625 inch) OD, 0.09 cm (0.035 inch) wall thickness, length of 1.4 m, and with  $\alpha = 0$ , has an inductance of 1.4  $\mu\text{H}$ . Because of the slowly varying nature of the log function in the above equation, a tube of 2.54 cm (1 inch) diameter, for example, has an inductance of 1.2  $\mu\text{h}$  -- a figure which provides sufficient accuracy in most instances.

The resistance of a conductor at dc and 20° C is given by the relation:

$$R = (0.17254/\sigma' A) \text{ milliohms/meter}$$

where  $\sigma'$  is the conductivity relative to copper at 20° C, and A is the cross-section in cm<sup>2</sup>. For 6061-T6 aluminum,  $\sigma' = 0.43$ . A 6061-T6 aluminum tube having 1.59 cm OD, 0.09 cm wall thickness and 1.4 m length has a dc resistance of 1.3 milliohms. Since the wall thickness is small with respect to the skin depth, resistance would only increase by 6 percent at 10 kHz.<sup>1</sup> Since inductive reactance is approximately 9 milliohms at 1 kHz and even greater at higher frequencies, this resistance is negligible. The resistance of a rolling wheel-axle set is a complex function of wheel and track condition, of frequency, and of current through the wheel. Since for frequencies above 500 Hz the value of actual axle resistance measured tread to tread is always larger than the 1.3 milliohm figure given above, the effects of actual axle resistance and wheel-rail contact resistance both can be accounted for by addition of series lumped resistance, as shown in Figure RT/IE04A-A1.

### 3. RAIL IMPEDANCE

At audio-frequencies, rail impedance is essentially inductive, with a value of X/R typically greater than 9 at a frequency as low as 1 kHz. Running rails behave electrically at audio-frequencies as if they were cylinders with effective radius of 4.7 cm, or diameter of 9.4 cm (3.7 inches).

The inductance of a return circuit of identical straight parallel cylindrical conductors is given by the relation

$$L_R = 0.4 \ell \left[ \log_e(d/r) - (d/\ell) + (1/4)(d/\ell)^2 - \dots \right] \mu\text{h}$$

<sup>1</sup>Dwight, Electrical Coils and Conductors, McGraw-Hill, 1945

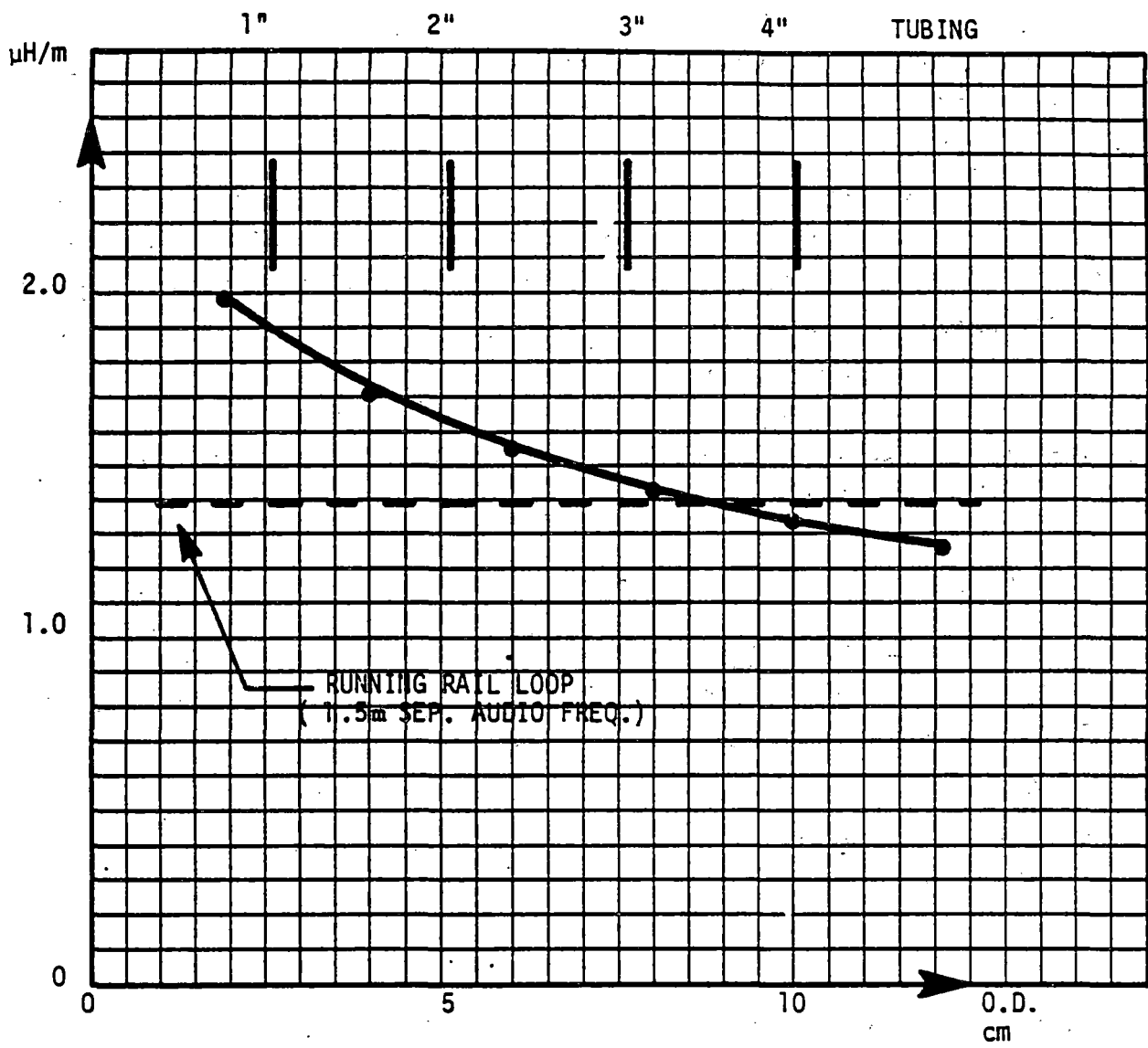

FIGURE RT/IE04A-A1. INDUCTANCE OF LONG RETURN CIRCUIT

where  $\ell$  is the length of the conductors,  $d$  the distance between their axes, and  $r$  their outer radius.<sup>1</sup> Because of the log function, inductance is only weakly dependent on radius, and frequently tubes with a diameter less than 9.4 cm can be used to simulate running rails. (See Figure RT/IE04A-A1.) At times, tubes as small as 2.54 cm (1 inch) in diameter have been used successfully.

The minimum diameter of a tube used to simulate the electrical characteristics of the rails depends directly upon the input impedance to the track circuit impedance bond at frequencies within the passband of track circuit receiver filters. That input impedance is typically in the range of 0.2 ohm to 0.5 ohm, and is resistive. If a tube with too small a diameter is chosen, results from Method RT/IE04A under TEST CONDITIONS A or B will predict erroneously low values of inductive interference. The error results from an unrealistically high ratio of simulated rail-wheel-axle impedance to bond input impedance.

The actual source inductance  $L_S$  seen by an impedance bond in Figure RT/IE04A-1 is maximum when the bond is attached to the rails midway between the interior axles of the car. For a car with an interior wheelbase of 16 meters, resting on standard-gage track with  $d = 1.5$  meters, the bond sees a source inductance due to two parallel loops of length 8 meters each terminated by an axle, plus the series inductance of the bond leads. Bond lead inductance  $L_B$  is typically approximately  $1.5 \mu\text{h}$ . Assuming then that each axle has inductance  $L_A = 1.4 \mu\text{h}$ , each loop has rail inductance  $L_R$  ( $d=1.5\text{m}$ ,  $r=4.7 \text{ cm}$ ,  $\ell = 8 \text{ m}$ ) =  $10.5 \mu\text{h}$ , and the impedance bond has lead inductance  $L_B = 1.5 \mu\text{h}$ , then the total series circuit inductance is  $L_S = L_B + (L_A + L_R)/2 = 7.45 \mu\text{h}$

---

<sup>1</sup>Trueblood & Wascheck, "Investigation of Rail Impedances," Electrical Engineering, December 1933.

This value of inductance, taken with an in-band bond input resistance  $R_B = 0.5$  ohm yields an upper half-power frequency for attenuation of interference signals of  $f_H = R_B / 2\pi L_S = 10.7$  kHz. (See Figure RT/IE04A-A2.) As long as this frequency is sufficiently higher than any signaling frequency of interest, tube diameter can be reduced without producing erroneously optimistic results, provided  $R_B$  is in the range of 0.5 ohm. However, in the case of much smaller  $R_B$ , for instance 0.15 ohm, the corresponding value of  $f_H$  becomes 3.2 kHz -- directly in the middle of the audio-frequency signaling range, and tube diameter cannot be reduced.

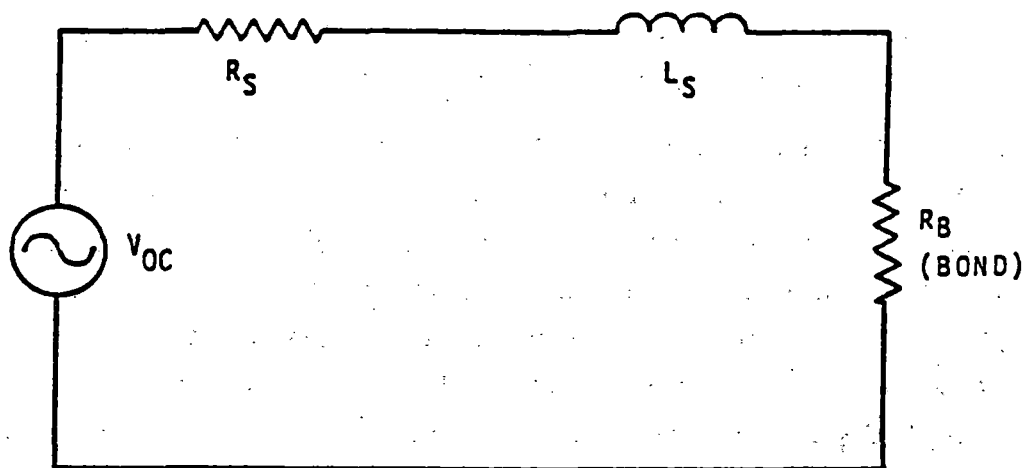

FIGURE RT/IE04A-A2. EQUIVALENT CIRCUIT OF UNDERCAR NETWORK



## APPENDIX A

### DEFINITIONS AND SYSTEMS OF UNITS

1. SCOPE - This section provides standard definitions and a system of units for the suggested test procedures.

#### 2. GENERAL INFORMATION

2.1 Definitions - Definition of terms used in these test procedures shall be determined by using the references in the order specified below:

- a. Section 3.0 (next section)
- b. MIL-STD-463A
- c. IEEE Standard Dictionary (Second Edition, 1977)

2.2 System of Units - System of units shall conform to IEEE standards.

#### 3. DEFINITIONS

CODE RATE - The frequency at which the track circuit signal is modulated.

EMMISSION, CONDUCTIVE - Desired or undesired current flowing from a source along an ohmic path.

EMISSION, INDUCTIVE - Desired or undesired magnetic flux which is propagated through space.

FLUX MAPPING - The process of determining the spatial distribution of a magnetic field emanating from a source.

FREQUENCY, TRACK CIRCUIT - The frequency of a sinusoidal audio-frequency signal occurring during the on-portion of the code-rate cycle.

INTERFERENCE, CONDUCTIVE - Interference caused by current flowing through a common ohmic path between the emission source and the susceptible circuit.

INTERFERENCE, INDUCTIVE - Interference caused by inductive emissions.

RAIL-TO-RAIL VOLTAGE - The voltage occurring at a point on one rail with respect to the opposing point on the adjacent rail.

SUSCEPTIBILITY, CONDUCTIVE - The degree to which equipment, together with all conductors associated with its intended function, evidences undesired end responses caused by conductive emissions to which it is exposed.

SUSCEPTIBILITY, INDUCTIVE - The degree to which equipment, together with all conductors associated with its intended function, evidences undesired end responses caused by inductive emissions to which it is exposed.

SUSCEPTIBILITY THRESHOLD - Limiting characteristics of an interfering signal which caused an undesired response under defined operating conditions.

TRACK CIRCUIT, AUDIO-FREQUENCY - A train detection and communication scheme generally operating above 300 Hz using the rails as the transmission link. These track circuits do not require, but may use insulated joints to establish their boundaries, and are, in rail transit applications, generally less than 2000 feet in length. Also, they generally operate at receiving-end current levels of less than 1.0 amperes.

TRACK CIRCUIT, POWER FREQUENCY - A train detection and communications scheme operating in the 0 to 300 Hz range using the rails as the transmission link. These track circuits require the use of insulated joints to provide the track circuit boundaries, and generally are used where long track circuits are required. Also, they generally operate at current levels in the ampere range.

TRACK CIRCUIT SIGNALING, AUDIO-FREQUENCY - The system employed to vitally control safe train movement, using audio-frequency track circuits. The functions of train detection and train separation control are involved. Cab signaling, overspeed detection, and other ATP related parameters may also be involved.

TRACK CIRCUIT SIGNALING, POWER FREQUENCY - The system employed to vitally control safe train movement, using power frequency track circuits. The functions of train detection and train separation are involved. Cab signaling, overspeed, and other ATP related parameters may also be involved.

VEHICULAR ELECTRICAL POWER SUBSYSTEM - Those transit vehicle devices involved in converting the prime power into forms for utilization by the car, viz., inverters, converters, propulsion controllers, etc.

APPENDIX B

SAMPLE TEST OUTPUTS USING INDUCTIVE  
SUGGESTED TEST PROCEDURES

<u>METHOD</u>	<u>EXAMPLE</u>	<u>PAGES</u>
RT/IS01A	GRS	B-2 - B-3
RT/IS01A	US & S	B-4 - B-5
RT/IE01A	MARTA	B-6 - B-7
RT/IE01A	BART	B-8 - B-9
RT/IE04A	GARRETT LAB	B-10

**SYSTEM TESTED:** GRS (BRAINTREE EXTENSION)      **FIELD LOCATION:** MBTA CABOT SIGNAL BLDG.  
**TEST PERFORMED:** RT/ISO1A      **BY WHOM:** R. GAGNON & J. CADIGAN (DOT/TSC)  
**COMMENTS:** TRACK CIRCUIT DRAWING / 58521-7 (MAINTENACE TEST UNIT)      **DATE:** 3/31/80

RUN #	INSTRUMENT SETTINGS	SCENARIO
28	SELECT PROPER CODE RATE AND FREQUENCY CARRIER	SEE PROCEDURE RT/ISO1A PARAGRAPH 4

**APPARATUS USED:** SIGNAL GENERATOR (NOTE 3). AMPLIFIER (HEINTOSH-HC 240)  
 FREQUENCY COUNTER (H/P 3403A). OSCILLOSCOPE (H/P 1701B)

**DIAGRAM: TEST MEASUREMENT**  
  
 SEE FIGURE RT/ISO1A-1 (NOTE 1 AND NOTE 2)

**NOTE 1 UNMODULATED TRANSMITTER REPLACED BY 14 mh COIL AND 400 Ω RESISTOR IN PARALLEL.**  
**NOTE 2 0.1 μ fd CAPACITOR PLACED ACROSS RECEIVED TERMINALS FOR LINE COMPENSATION**  
**NOTE 3 A ROCKLAND SYNTHESIZER MODEL 5100 MODULATED AT THE CODE RATES USED IN PLACE OF SPECIFIED SIGNAL GENERATOR**

B-2

SYSTEM TESTED: GRS (BRAINTREE EXTENSION)

FIELD

LOCATION: MBTA CABOT SIGNAL BLD

TEST PERFORMED: RT/ISOIA

BY WHOM: R. GAGNON + J. CADYGAN

DATE: 4/22/80

OPERATING FREQUENCY:  $f_s = 3060\text{Hz}$

$V_I$  = INTERFERENCE LEVEL IN  $\text{mV RMS}$

$V_I$	CODE RATE - HZ														
	0.1	0.2	0.5	1.0	2.0	5.0	10	20	50	100	100	200	200	500	275
500	-	-	-	2895	2895	2860	2705	2600	2395	N	N	N	N	-	-
	-	-	-	3220	3220	3285	3450	3575	3705	N	N	N	N	-	-
250	-	-	-	2920	2920	2910	2880	2840	2785	N		N		-	-
	-	-	-	3200	3200	3215	3270	3350	3420	N		N		-	-
125	-	-	-	2935	2935	2925	2920	2915	2895	-		N		-	-
	-	-	-	3195	3195	3200	3210	3220	3240	-		N		-	-
62.5	-	-	-	2955	2955	2955	2955	2955	2950	2960		-		-	-
	-	-	-	3170	3170	3170	3170	3175	3200	3170		-		-	-
31.3	-	-	-	-	-	-	-	-	-	-		-		-	-
	-	-	-	-	-	-	-	-	-	-		-		-	-
15.6	-	-	-	-	-	-	-	-	-	-		-		-	-
	-	-	-	-	-	-	-	-	-	-		-		-	-

FREQUENCY - HZ

—: NO-PICK OF RELAY

°: MOMENTARY PICK OF RELAY

N: RELAY PICKS IN NARROW RANGE OF FREQUENCIES NEAR THIS VALUE

SYSTEM TESTED: U S & S (HAYMARKET NORTH)

FIELD

LOCATION: MBTA CABOT SIGNAL BLD

TEST PERFORMED: RT/ISO1A

BY WHOM: R. GAGNON & J. CADIGAN (DOT/TSC)

COMMENTS: TRACK CIRCUIT AF-200

DATE: 3/28/80

RUN #	INSTRUMENT SETTINGS	SCENARIO
33	SELECT PROPER CODE RATE AND CARRIER FREQUENCY	SEE PROCEDURE RT/ISO1A PARAGRAPH 4

APPARATUS USED: SIGNAL GENERATOR (NOTE 1), AMPLIFIER (McINTOSH - Mc240)

FREQUENCY COUNTER (H/P 5327B), RMS VOLTMETER (H/P 3403A), OSCILLOSCOPE (H/P 1701B)

DIAGRAM: TEST MEASUREMENT

SEE FIGURE RT/ISO1A - 1

NOTE 1 ROCKLAND SYNTHESIZER MODEL 5100, MODULATED AT THE CODE RATES, WAS  
USED IN PLACE OF SPECIFIED SIGNAL GENERATOR

NOTE 2

NOTE 3

**FIELD**  
**SYSTEM TESTED:** US & B (HAYMARKET NORTH) **LOCATION:** MBTA CABOT SIGNAL BLD  
**TEST PERFORMED:** RT/ISO1A **BY WHOM:** R. GAGNON & J. CADIGAN (DOT/TBC)  
**DATE:** 4/17/80 **OPERATING FREQUENCY:  $f_o$  =**  
 **$V_I$  = INTERFERENCE LEVEL IN mV RMS**

$V_I$	CODE RATE - HZ											
	0.1	0.2	0.5	1.0	2.0	5.0	10	20	50	100	62.5	75
500	★ 1530	★ 1530	★ 1530	—	—	1495	1485	1490	1520	—	1595	—
	★ 1645	★ 1640	★ 1640	—	—	1675	1700	1700	1590	—	1660	—
250	★ 1540	★ 1540	★ 1540	—	—	1530	1525	1525	1525	—	1570	—
	★ 1630	★ 1630	★ 1630	—	—	1630	1650	1650	1605	—	1645	—
125	★ 1540	★ 1550	★ 1550	—	—	1550	1545	1545	1550	—	—	—
	★ 1625	★ 1625	★ 1620	—	—	1630	1625	1625	1570	—	—	—
62.5	—	—	—	—	—	—	—	N 1580	—	—	—	—
	—	—	—	—	—	—	—	N 1590	—	—	—	—
31.3	—	—	—	—	—	—	—	—	—	—	—	—
	—	—	—	—	—	—	—	—	—	—	—	—
15.6	—	—	—	—	—	—	—	—	—	—	—	—
	—	—	—	—	—	—	—	—	—	—	—	—

B-5

— : NO-PICK OF RELAY  
 ★ : MOMENTARY PICK OF RELAY  
 N : RELAY PICKS IN NARROW RANGE OF FREQUENCIES NEAR THIS VALUE

FREQUENCY - HZ



**SYSTEM TESTED:** MARTA **FIELD LOCATION:** EASTLAKE STATION  
**TEST PERFORMED:** RT/IE01A **BY WHOM:** R. GAGNON (DOT/TSC)  
**CARS IN CONSIST:** 4 CAR CONSIST **WEATHER:** FAIR  
**COMMENTS:** RAIL TO RAIL CONNECTION MADE IN TRACK CIRCUIT ER-261  
**NO FLAT WHEELS** **DATE:** 8/22/79

RUN #	START FOOTAGE	STOP FOOTAGE	CAR SPEED	DIRECTION	SCENARIO
58	969'	978'	210MPH	WEST BOUND	P4 TRAIN STARTED JUST AT ENTRANCE TO BLOCK. SEE RT/IE01A PARA 4 NOTE 1

**APPARATUS USED:** AS SPECIFIED IN RT/IE01A

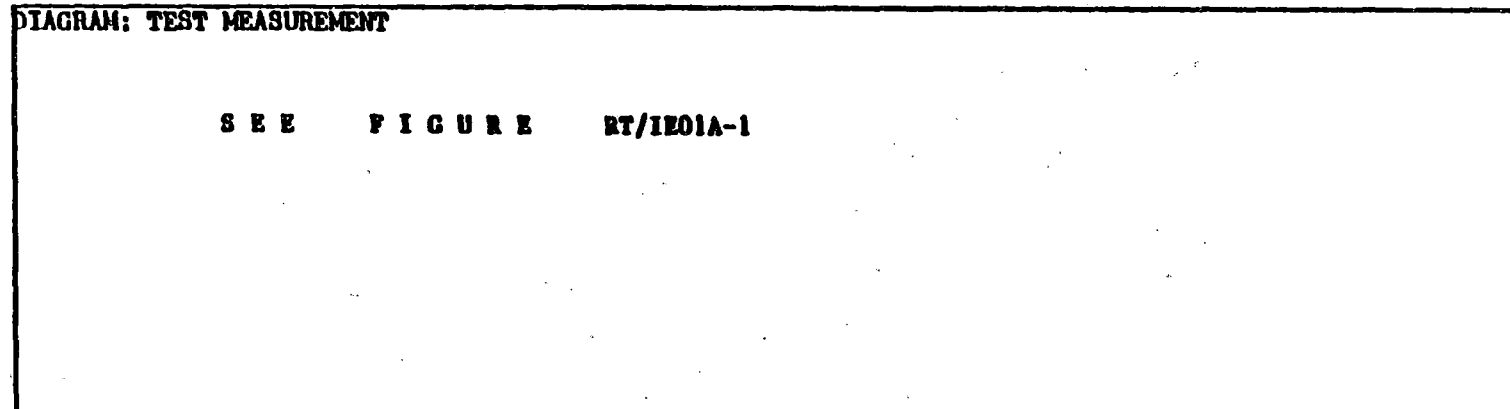

- NOTE 1 MARTA TAPE #1
- NOTE 2
- NOTE 3
- NOTE 4

B-6

NOTE: DISREGARD SPURIOUS MEASUREMENT RESPONSE AT ZERO HZ

RMS INPUT AC  
0 DBV 1.00V

AVG (M)

FREE-RUN

HANN

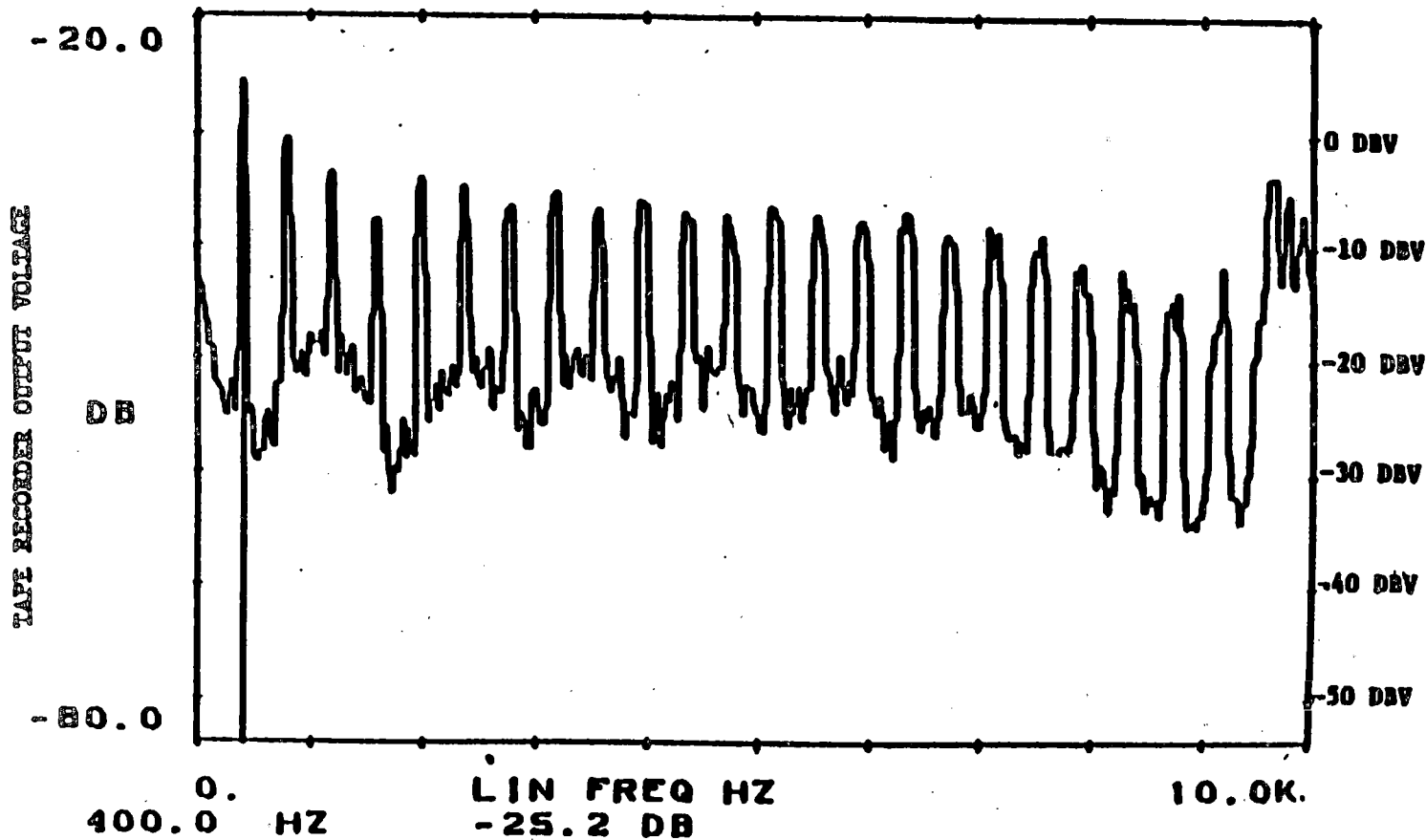

HZ	DB
400	-25.2
800	-30.0
1.2K	-32.9
1.6K	-37.3
2.0K	-33.9
2.4K	-37.1
2.8K	-35.4
3.2K	-34.6
3.6K	-38.7
4.0K	-35.5
4.4K	-37.0
4.8K	-39.7
5.2K	-36.6
5.6K	-38.7

SYSTEM TESTED: BART

FIELD

LOCATION: HAYWARD TEST TRACK

TEST PERFORMED: RT/IE01A

BY WHOM: R. GAGNON

CARS IN CONSIST: 4 CAR CONSIST

WEATHER: DAMP MISTY

COMMENTS: NO FLAT WHEELS

DATE: 1/16/80

RUN#	START FOOTAGE	STOP FOOTAGE	CAR SPEED	DIRECTION	SCENARIO
21	674'	705'	24 MPH	SOUTHBOUND	FULL POWER MANUAL RUN STARTED 120' FROM MEASUREMENT POINT. NOTE 1 SEE RT/IE01A PARA 4

APPARATUS USED: AS SPECIFIED IN RT/IE01A

DIAGRAM: TEST MEASUREMENT

SEE FIGURE RT/IE01A.

NOTE 1 BART TAPE #1

NOTE 2

NOTE 3

NOTE 4

NOTE: DISREGARD SPURIOUS MEASUREMENT RESPONSE AT ZERO HZ  
MEASUREMENT SYSTEM THROUGHPUT FACTOR = -13.2 DB

RMS INPUT AC  
+10 DBV 3.16V

AVG (M)

FREE-RUN

HANN

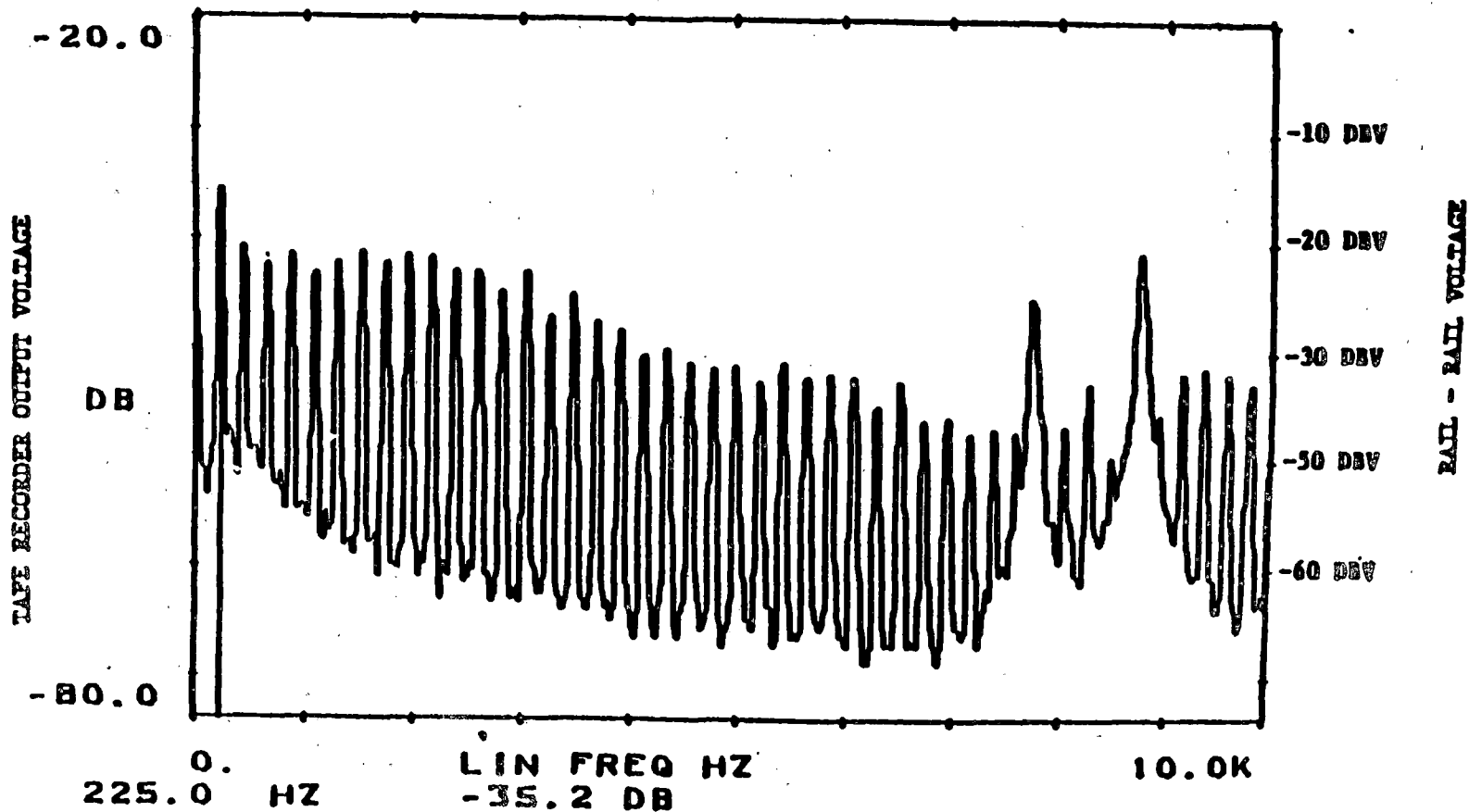

RAIL - RAIL VOLTAGE FOR BART RUN NO. 21. FULL POWER 24 M.P.H.

SYSTEM TESTED: EXPERIMENTAL CHOPPER  
TEST PERFORMED: RT/IE04A TEST CONDITION A  
COMMENTS: ZERO ADDED AXLP DISTANCE

FIELD LOCATION: GARRETT TORRANCE CALIF.  
BY WHOM: R. RUDICH (GARRETT)

DATE: 3/13/80

RUN #	INSTRUMENT SETTINGS	SCENARIO
10		RT/IE04A PARA 4.0 TEST CONDITION "A"

APPARATUS USED: AS SPECIFIED IN PARA. 3.0 OF RT/IE04A

DIAGRAM: TEST MEASUREMENT

SEE FIGURE RT/IE04A-1

NOTE 1  
NOTE 2  
NOTE 3  
NOTE 4

NOTE: DISREGARD SPURIOUS MEASUREMENT RESPONSE AT ZERO Hz

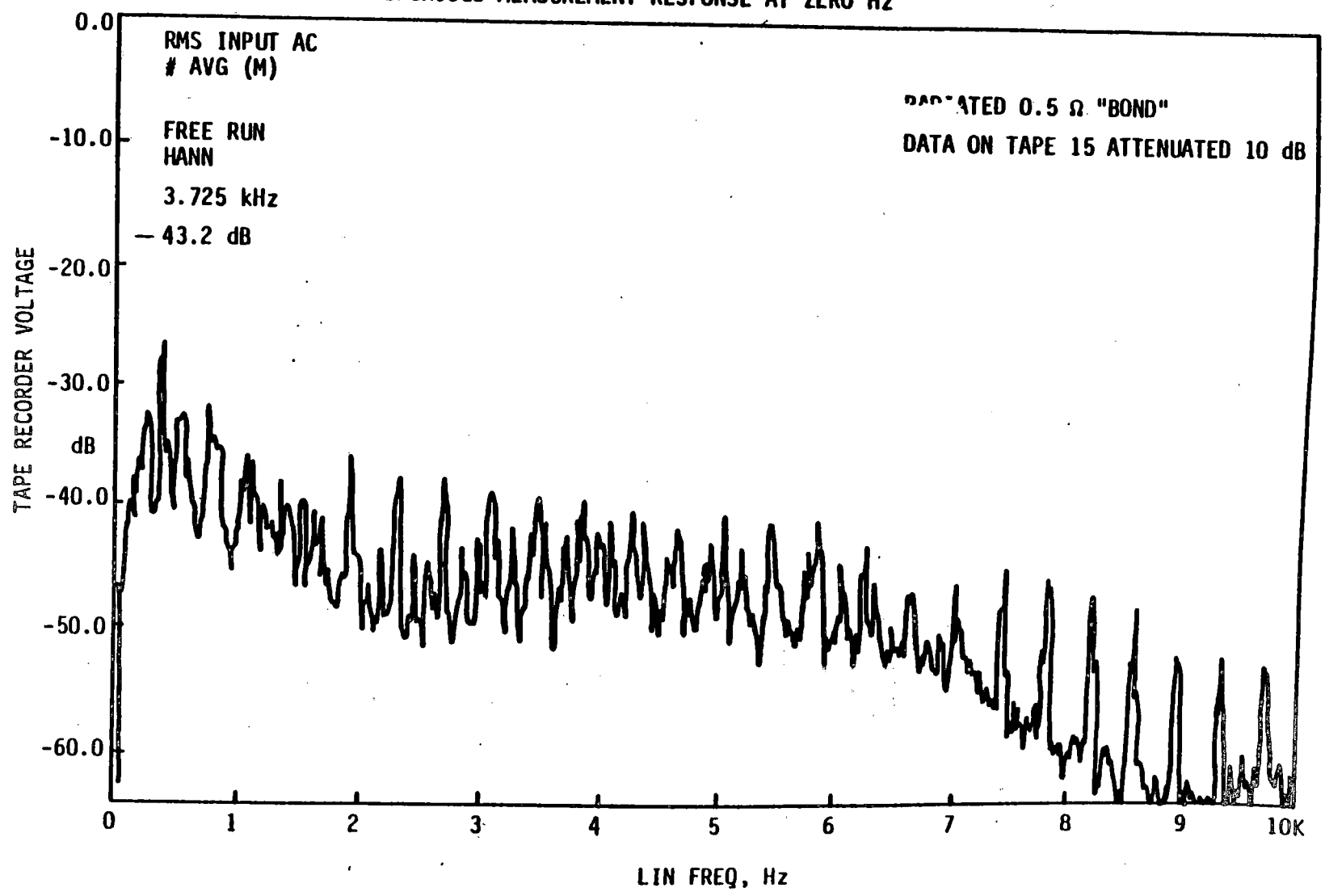

B-11

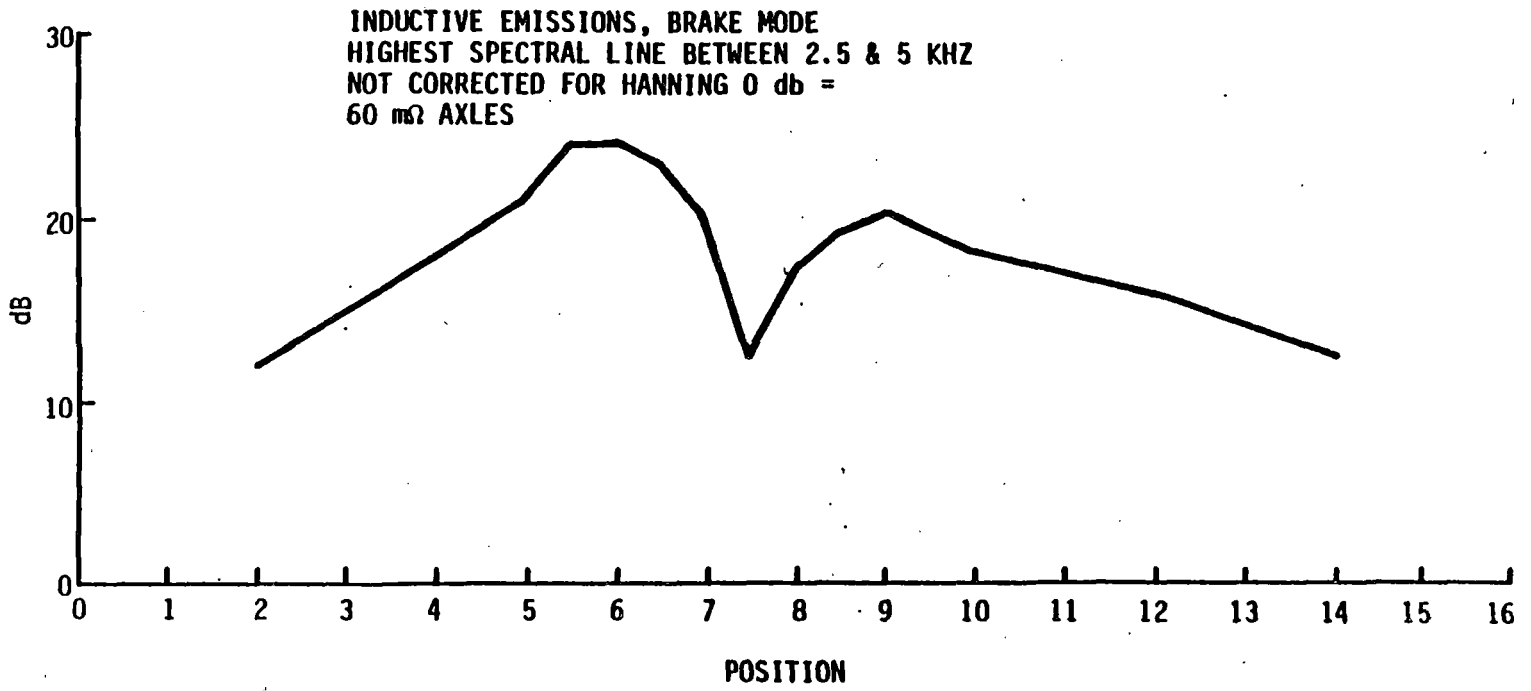

U.S. Department  
of Transportation

**Research and  
Special Programs  
Administration**

Kendall Square  
Cambridge, Massachusetts 02142

Official Business  
Penalty for Private Use \$300



Postage and Fees Paid  
Research and Special  
Programs Administration  
DOT 513

