



U.S. Department
of Transportation

Federal Railroad
Administration

Assessment of the Potential for Magnetic Levitation Transportation Systems in the United States

A Report to Congress

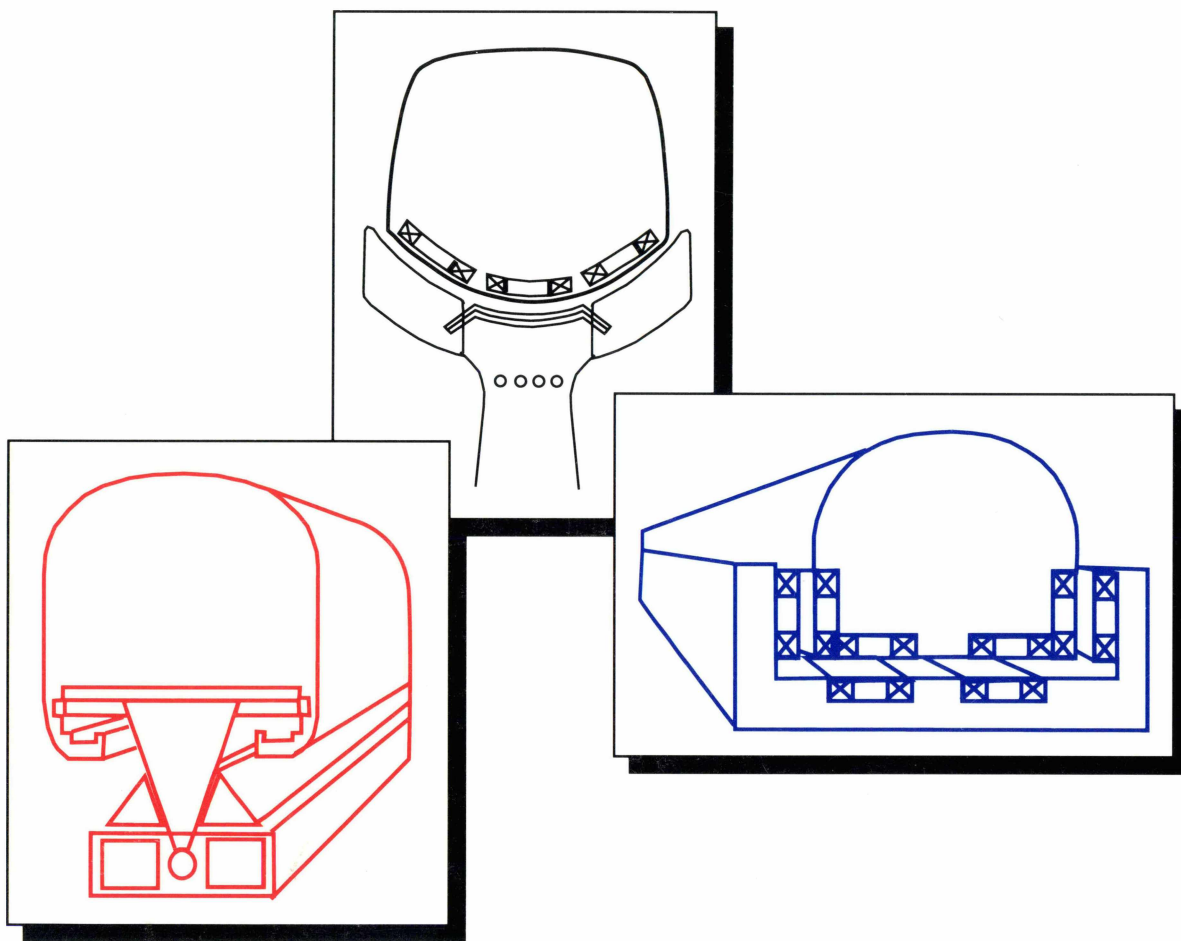

Moving America
New Directions, New Opportunities



June 1990

Table of Contents

Foreword.....	v
Preface.....	vii
Executive Summary.....	E-1
Chapter One: Introduction.....	1
Chapter Two: The Current State of Magnetic Levitation Technology.....	5
Chapter Three: Technical Feasibility.....	9
U.S. Maglev Technology Development Opportunities.....	9
Development Strategies.....	11
Technical Issues Requiring Further Investigation.....	12
Chapter Four: Economic Feasibility.....	13
Previous U.S. Studies.....	13
Economic Analysis of U.S. Maglev Potential.....	14
Conclusions of the Economic Feasibility Assessment.....	17
Economic Issues Requiring Further Investigation.....	19
Chapter Five: Measures to Promote U.S. Leadership in Maglev.....	21
Stimulating Maglev Research and Development.....	21
Facilitating Implementation of Specific Maglev Projects—Institutional and Regulatory Issues.....	23
Financing Implementation of Maglev Projects.....	24
Future Action.....	25

Foreword

Most major industrialized nations are engaged in a race for leadership in high-speed ground transportation technology. Conspicuous by its absence from this race is the United States. A major transportation policy issue facing us today is whether we should join this race or be content with being a customer for transportation technology developed and manufactured overseas.

There is no doubt that the United States can benefit from safe high-speed ground transportation. Across our Nation, there is increasing concern about transportation congestion and its adverse impact on air quality, personal mobility, and commerce. Delays caused by congestion alone are costing consumers and U.S. industries billions of dollars of taxable income annually. Projections by the Department of Transportation indicate steadily worsening conditions in the future.

No single form of transportation will be able to meet the full range of the Nation's future transportation requirements. However, magnetically levitated transportation systems (maglev), an emerging technology with maximum speeds in excess of 300 miles per hour, offers the potential for safely and efficiently meeting part of these requirements. At such high speeds, maglev could be particularly competitive for large numbers of trips of between 100 and 500 miles in length.

Looking to the last decade of this century and the beginning of the 21st century, our Nation has the prospect of obtaining substantial benefits from this exciting new technology. The United States has a long and rich history of scientific and technological breakthroughs in transportation. That tradition will be put to test, as we explore the various possibilities for maglev in the United States.

The National Transportation Policy, announced by President Bush and Secretary Skinner on March 8, supports Federal research to advance the implementation of emerging transportation technologies such as maglev. This preliminary report is the first step in the Administration's examination of the possibilities of maglev systems in the United States. The President's Fiscal Year 1991 budget requests that Congress fund the next step: research to evaluate the potential of an American-made maglev technology and the role that the Federal Government should play in its development. In light of the race to develop high-speed ground technology, we must move aggressively to explore the full range of options for developing and implementing this exciting new transportation technology.

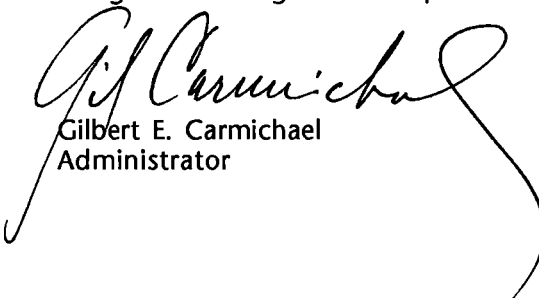

Gilbert E. Carmichael
Administrator

Preface

The Fiscal Year 1989 Appropriations Committee Conference Report (100-957) directed the Federal Railroad Administration (FRA) to undertake an analysis of the feasibility of magnetic levitation, or maglev, transportation systems in the United States. Specifically, the Conference Report directed FRA to conduct:

“An assessment of the current state of magnetic levitation technology, including an analysis of the economic and technical feasibility of constructing commercial magnetic levitation transportation systems in the United States over the next 20 years and the identification of legislative or other measures that could be undertaken to promote U.S. industry leadership in the production of such equipment.”

This report and its supplement address in detail the questions posed by the Congress.

The report is divided into the following sections:

- Introduction and Background
- Current state of maglev technology
- Preliminary analysis of the technical feasibility of maglev systems

- Preliminary analysis of the economic feasibility of maglev systems
- Measures to promote U.S. leadership in maglev development.

The Report Supplement presents a more detailed exposition of these issues. The detailed views of U.S. industry on maglev technology development in the United States will be published in a separate report.

Moving America, A Statement of National Transportation Policy, issued in March 1990, identifies strategies and actions to prepare the Nation for the transportation challenges of the 21st century. Embedded in this statement is the recognition that innovation and technology are vital to achieving the goals and objectives of our future transportation needs. Advancing U.S. transportation technology and expertise in new forms of transportation will contribute to that end. *Assessment of the Potential for Magnetic Levitation Transportation Systems in the United States* evidences that maglev is one of several technological advances that has received a substantial initial impetus from U.S. research and development.

Executive Summary

Surface and air travel are projected to double from 1988 levels early in the 21st century. Magnetic levitation (maglev) is a relatively new transportation technology, which has the potential to alleviate growing highway and airway congestion, particularly in high-density intercity corridors. Maglev vehicles can travel safely and at relatively high speeds while suspended above a guideway by magnetic fields. Operating at maximum speeds of over 300 miles per hour (mph), maglev could be very competitive with short-haul air service and highway trips, attracting large numbers of business and other time-sensitive travelers. Maglev systems can be designed to provide efficient intermodal connection for travelers at multimodal terminals in city centers, airports, and other key locations.

Current Maglev Technology

The three primary functions basic to maglev technology (Figure ES-1) are: (1) levitation or suspension; (2) propulsion; and (3) guidance.

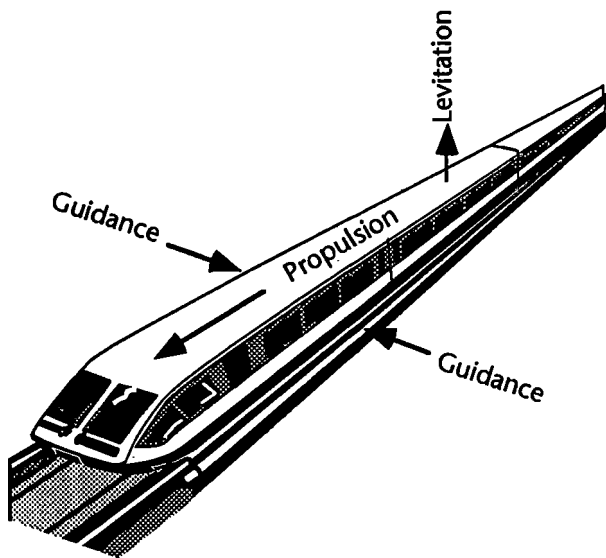

Figure ES-1. The Three Primary Functions Basic to Maglev Technology

In most current designs magnetic forces are used to perform all three functions although a non-magnetic source of propulsion could be used. No consensus exists on an optimum design to perform each of the primary functions.

Suspension Systems

The two principal means of levitation are illustrated in Figures ES-2 and ES-3. *Electromagnetic suspension (EMS)* is an attractive force maglev levitation system whereby electromagnets on the vehicle interact with and are attracted to ferromagnetic rails on the guideway. EMS was made practical by advances in electronic control systems that maintain the air gap between vehicle and guideway, thus preventing contact. Variations in payload weight, dynamic loads,

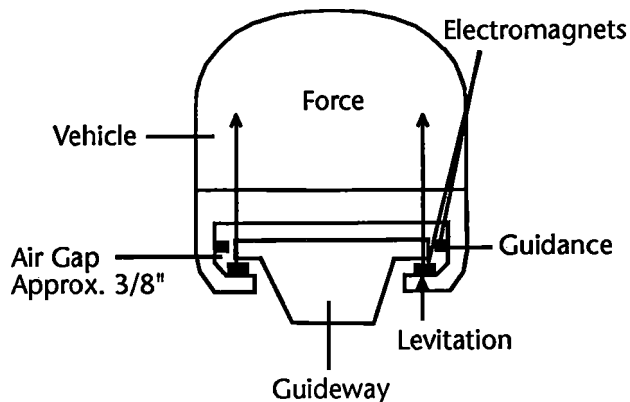

Figure ES-2. Electromagnetic Maglev

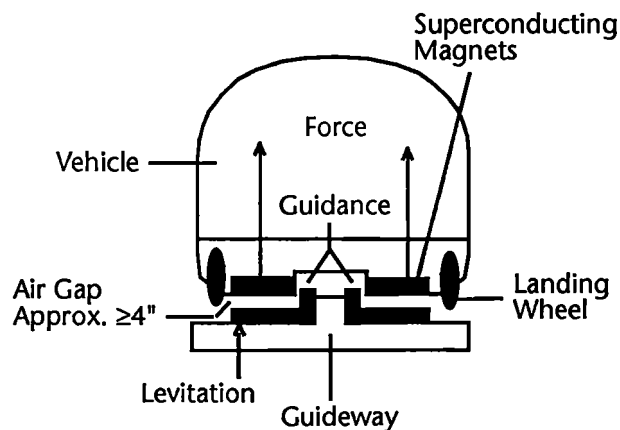

Figure ES-3. Electrodynamic Maglev

and guideway irregularities are compensated for by changing the magnetic field in response to vehicle/guideway air gap measurements.

Electrodynamic suspension (EDS) employs magnets on the moving vehicle to induce currents in the guideway. This resulting repulsive force produces inherently stable vehicle support and guidance because the magnetic repulsion increases as the vehicle/guideway gap decreases. However, the vehicle must be equipped with wheels for "takeoff" and "landing" because the EDS will not levitate at speeds below 25 mph. EDS has progressed with advances in cryogenics and superconducting magnet technology.

Propulsion Systems

"Long-stator" propulsion using an electrically powered linear motor winding in the guideway appears to be the favored option for high-speed maglev. It is also the most expensive because of higher guideway construction costs.

"Short-stator" propulsion uses a linear induction motor (LIM) winding on board and a passive guideway. While short-stator propulsion reduces guideway costs, the LIM is heavy and reduces vehicle payload capacity resulting in higher operating costs and lower revenue potential compared to long-stator propulsion. A third alternative is a non-magnetic energy source (gas turbine or turbo-prop) but this, too, results in a heavy vehicle and reduced operating efficiency.

Guidance Systems

Guidance or steering refers to the sideward forces that are required to make the vehicle follow the curves and straightaways of the guideway. The necessary forces are supplied in an exactly analogous fashion to the suspension forces, either attractive or repulsive. The same magnets on board the vehicle which supply lift can be used concurrently for guidance, or separate guidance magnets can be used.

Technical Feasibility

Both EMS and EDS systems appear suitable for U.S. deployment. EMS advantages include a high-speed prototype demonstrating good ride quality, off-line switching capability, and very low ambient magnetic field levels. The EDS is lighter and requires less power per

seat-mile. Also, its larger allowable gap between vehicle and guideway requires less precise guideway construction and vehicle control. Current designs of both systems use the long stator, requiring an actively powered guideway which accounts for a large percentage of system capital costs.

Another system design, the Magneplane, while only in the conceptual stage, merits further study. It uses an EDS suspension system, but a cylindrical geometry, which permits the vehicle to roll about its axis. This design feature, which includes a stabilizing magnetic "keel," reportedly allows the Magneplane to negotiate curves effectively.

A number of continuing research and development opportunities still exist, many common to both EMS and EDS:

- **Guideway Structure**—Fixed facilities account for about 90 percent of overall maglev capital costs. Seventy percent of this stems from the guideway structure. Any technological improvements in this area could have a substantial impact on system economics.
- **Right-of-Way**—Interstate Highway and railroad rights-of-way represent potentially valuable resources for accommodating maglev routes. Use of these resources needs further investigation because highways and railroads were originally designed for speeds well below 100 mph. Many have curves and clearances that may constrain higher maglev speeds.
- **Propulsion System Innovation**—Long-stator windings, which run the length of the guideway, are a major element of capital cost. Breakthroughs in design or in use of alternative propulsion concepts could reduce capital cost and hasten implementation.
- **Operational Considerations**—High-speed switching is a major operating challenge for a U.S. maglev system, because switches are among the least developed components.

Another important operating consideration that needs further study is whether to use multicar trains with a limited number of intermediate stops or single-car trains serving individual pairs of stations, some of which are located on branch lines.

- Other Development Opportunities—High-temperature superconducting magnets, limiting exposure to magnetic fields, improved stabilization, and better cryogenic systems are also areas where development opportunities exist.

Economic Feasibility

The economic feasibility analysis is focused on high-speed travel networks connecting center cities from 100 to more than 500 miles apart and serving selected airports. Revenues and costs are in 1988 dollars.

The preliminary economic feasibility finding is that a number of transportation markets, comprising from less than 500 to 2,600 miles of maglev routes, could generate sufficient revenues from fares to cover operating and capital costs, excluding right-of-way costs and assuming access to tax-free bond financing. The analysis supporting this finding assumes continued growth in travel markets and modal service characteristics that result in an overall market share of 27 percent for maglev.

A larger number of markets could generate sufficient revenues from fares to cover operating costs, and at least half of capital costs. In such cases, non-transportation revenues, such as revenues derived from the capture of part of the increased real estate values near stations, could offset portions of the capital-needs shortfall. Table ES-1 summarizes these findings.

Table ES-1. Estimated Maglev Route-Miles Covering Operating Costs Plus Different Percentages of Capital Costs

<i>Recovery of Capital Cost*</i>	<i>Unfavorable Scenario</i>	<i>Base Scenario</i>	<i>Favorable Scenario</i>
100 percent	<500	850	2,600
50 percent	1,500	3,000	5,000

* Excludes right-of-way costs

Future transportation demand and preferences in transportation mode are dependent on numerous variables that make accurate projections extremely difficult. Therefore, this analysis considered a range of assumptions about these variables. There is a

base scenario which reflects the assumptions that are detailed in Chapter Four. Altering some of these underlying assumptions, such as reducing the assumed cost of guideway construction (the single greatest cost involved in building a maglev system), would increase the number of transportation markets where maglev would appear to be viable. On the other hand, increasing the assumed capital and/or operating costs or decreasing the number of projected maglev passengers would increase the number of maglev markets that would require support from non-transportation revenues. For that reason a favorable and an unfavorable scenario were also analyzed.

The favorable scenario reflects assumptions favorable to maglev development, such as increased highway and airport congestion and lower guideway costs. The unfavorable scenario represents assumptions including a 25 percent increase in assumed fixed capital costs and a 100 percent increase in assumed operating costs.

Still another, more pessimistic scenario can be constructed using these same unfavorable conditions and assuming that ridership is 25 percent below base projections. In this case, no maglev system would cover its capital costs.

A basic assumption embedded in all scenarios is that rights-of-way would be available at low cost or no cost, that is, rights-of-way would be either provided at State or local expense or would be available on public property adjacent to existing highways or other transport facilities. Several states have already announced plans to provide access to highway and railroad rights-of-way.

These findings suggest that there is a role for maglev in the future U.S. transportation system. However, the market for maglev facilities and equipment may not be large enough and certain enough to induce U.S. industry to make a significant commitment of its own resources to a maglev technology development program at this time.

If, however, the installed cost to private developers could be reduced significantly, a much expanded network of self-sufficient maglev systems might be financed and operated. Two ways that this could be accomplished are: (1) through an innovative research and development effort to drive

down construction costs or (2) through interested States and local governments cooperating with developers in programs to supplement maglev transportation revenues.

While maglev appears technically and economically feasible in a limited number of regions, much remains to be done to reduce installed costs to the private sector before a similar conclusion can be drawn about a national maglev network.

This report does not contain an analysis of maglev versus high-speed rail or other solutions for intercity transportation. This will be left to later studies.

Measures to Promote U.S. Industry Leadership

A number of institutional issues present obstacles that deter U.S. industry from assuming a leadership role in maglev. Perhaps no issue or group of issues will be more important to a successful maglev development program than the public-private partnership necessary to carry out that development. FRA has met with a broad range of companies that might be expected to participate in maglev technology development and applications. Highlighting the shortage of private funds for research and development, the companies expressed the view that before an effective public-private partnership could be created, the Federal Government must make a long-term commitment to maglev. The primary focus of this commitment must be financial support for maglev technology research and for new high-speed ground transportation applications. Furthermore, industry believes that to reinforce this commitment, the following actions should be considered by the Federal Government:

- A clear and realistic definition of the future role and market for maglev
- Significant R&D funding, initially perhaps as much as a 90% share
- A National policy toward high-speed ground transportation
- Legislation to support maglev research, development, and implementation
- A Government organization to champion the maglev program and a structured Government-industry team

- Standards for maglev design and construction
- Capital, rights-of-way, and/or operating cost subsidies, as required
- A detailed assessment of environmental and safety issues.

In effect, industry is saying that the Federal Government must assume the risks for development and initial implementation of an American-made maglev system in the United States.

Action on these industry views would imply a substantial allocation of Federal managerial and financial resources. Evaluation of these suggestions is beyond the scope of this report, but FRA believes that if a major development program were to proceed, it should be a joint undertaking involving significant private investment. FRA believes that it is premature to decide on the specifics of such a program at this time.

Preliminary Assessment and Conclusions

This preliminary assessment indicates that development of commercial maglev systems in the United States within the next 20 years, and indeed, perhaps within the next 10 years, is both economically and technically feasible. Furthermore, there is potential for U.S. industry to establish a lead role in the commercial applications of maglev. This will depend largely on the creation of effective public-private partnerships to advance the technology and to remove certain institutional barriers.

These conclusions are preliminary because of the limited scope of the studies on which the findings are based. Further studies to accelerate understanding of the potential role of maglev in the Nation's transportation future are included in the President's Budget for Fiscal Year 1991. Many technical and economic feasibility issues identified during this investigation require further research and evaluation. The five priority issues are:

- the cost of assembling an adequate right-of-way, the feasibility of using existing transportation and utility rights-of-way, and related design and system-speed tradeoffs;

- the improvement of design and construction methods and other means of reducing guideway costs;
- the configuration of a maglev system for the United States that would address such issues as vehicle size, network configuration, and service frequency;
- the safety, environmental and health impacts of maglev systems and the means of minimizing magnetic field effects; and
- the financing of maglev research and development.

The Departments of Transportation and Energy, the U.S. Army Corps of Engineers, EPA, and other Federal agencies with interests or

expertise in maglev-related areas are coordinating their activities in an effort called the National Maglev Initiative. Building on the preliminary results of this study and other research, the Initiative will review the safety, engineering, economic, and environmental aspects of maglev and assess its possible role in the Nation's transportation system. Among the analyses to be undertaken will be a study of the role of maglev versus other modes of transportation, including high-speed rail. Information from this effort will form the basis for recommendations on the future development of an American made maglev in the United States and on the appropriate role for the Federal Government in this development.

Chapter One

Introduction

Background

As the 21st century approaches, it is increasingly apparent that today's transportation systems cannot accommodate the travel needs anticipated over the next several decades. By 2020, surface travel in the United States is expected to double from 1988 levels and average surface speeds are expected to continue to decrease. In addition, the number of airline passengers is expected to increase by about two thirds by 2000 and double again by the year 2020. Meanwhile, it may not be feasible to expand the highway and air travel systems to serve this additional demand because of financial, environmental and community costs associated with such expansion.

Therefore, new transportation technology may provide a way to alleviate the highway and airport/airway congestion experienced today and the capacity problems expected tomorrow—particularly in high-density intercity corridors. Transportation alternatives must be evaluated now to meet the transportation needs of the next decade.

Maglev is one of these alternatives. Maglev vehicles are suspended above the guideway by magnetic fields and can travel safely and at relatively high speeds. These systems are flexible enough to be developed with efficient intermodal connections for travelers at city center multimodal terminals, airports, and other key locations. This technology offers a promising and potentially cost-effective alternative that could dramatically improve the quality of the Nation's transportation system.

The Cost of Intercity Congestion

The Nation pays a large price for traffic delay. For example, passengers at Chicago's O'Hare International Airport, one of 21 congested airports in the United States today, currently are delayed by more than 12 million hours annually. The cost of this delay to American businesses and the aviation industry at the 21 airports is estimated at \$5 billion annually. By 1997, 34 airports are projected to experience congestion at an estimated cost of \$8 billion, even with planned capacity improvements in place.

Congestion on the Nation's highways, including the Interstate system in urban areas, has reached alarming levels. A report prepared in October 1989 estimated that the economic impact of traffic congestion for 39 urban areas studied was \$41 billion per year in 1987 dollars. Inflation alone raised the amount to \$44 billion by 1989. Today, more than 2 billion production hours are lost annually because of highway congestion, costing the Nation approximately \$80 billion per year. By the year 2000, 70 percent of peak-hour travelers will experience highway congestion delays, while the cost will exceed \$100 billion annually. Furthermore, urban congestion will continue to spread to intercity highway segments.

The Role of Maglev in Intercity Transportation

Investments in maglev have the potential to lower airport and, to some extent, highway congestion levels and, thus, reduce overall transport costs. Maglev, which has the potential for safe speeds above 300 mph, could be very competitive with short-haul air service and many highway trips in this country, attracting large numbers of business and other time-sensitive travelers. Maglev systems could be especially effective in relieving pressure for expanded airport capacity by substantially reducing the need for short to medium-distance air trips and freeing available airport capacity for more efficient long-haul air service.

FRA's discussions with industry leaders have confirmed a widely held belief that an American maglev system must be carefully designed to fit into the Nation's total transportation system. The systems must be intermodal and flexible enough to provide safe, high-speed service between major markets while providing service for intermediate stops. To the extent practical, and to the extent that speed is not compromised by curvature restrictions, maglev systems should be designed using existing transportation rights-of-way and along existing highway, railroad, or utility rights-of-way to minimize cost and adverse environmental impacts.

Development Programs in Other Countries

A number of countries have conducted research and development programs in maglev, including Great Britain, Canada, the Federal Republic of (West) Germany, and Japan. In Great Britain, efforts have been limited to low-speed maglev; the Birmingham maglev provides low-speed shuttle service between the Birmingham airport and the Birmingham rail station.

Major programs have been underway in Japan and West Germany over the last two decades to develop and demonstrate maglev technology for high-speed ground transportation. No high-speed maglev system is yet in revenue service, although West Germany has spent more than \$1 billion dollars developing prototypes that have carried passengers on test runs, and the Japanese may have spent nearly as much on maglev research, development, tests, and demonstrations.

The Transrapid TR-07, developed by West Germany's Transrapid International, Inc., is being certified at present for high-speed service with prospects for deployment in West Germany and abroad. The TR-07 has a design peak-speed of 500 km/h (310 mph) and has operated at speeds as high as 432 km/h (270 mph) at the Emsland, West Germany, test facility. The West German government is in the final stages of approving construction of a revenue-service line to connect the Bonn/Cologne and Duesseldorf airports, a distance of approximately 80 km (50 miles). The line will eventually continue from Duesseldorf Airport to Essen Central Station.

Japan's EMS HSST-05, originally developed by Japan Airlines and now under the direction of the High-Speed Surface Transport (HSST) Corporation, was the first maglev system, worldwide, to be certified for revenue service. Between March and October 1989, it operated over a 568-meter (621 yard) track in revenue service at the Yokohama Exposition Site at speeds up to 80 km/h.

Japan has been the only country with a consistent, long-term commitment to the development of an EDS-type superconducting maglev system. Japan's current EDS program is the result of two decades of continuous research and development. An unmanned superconducting maglev test vehicle achieved a top speed of

517 km/h (321 mph) in test runs. Plans under consideration include revenue service by the year 2001 between Tokyo and Osaka; a new 40- to 45-km (25- to 28-mile) test facility on that line is expected to be completed by mid-1994. Several other routes in Japan are also under consideration.

U.S. Maglev Initiatives

Past U.S. Maglev Efforts

Under the High Speed Ground Transportation Act of 1965, FRA funded a wide range of research into all forms of high-speed ground transportation through the early 1970s. In 1971, FRA awarded contracts to the Ford Motor Company and the Stanford Research Institute for analytical and experimental development of EMS and EDS levitation systems. Rohr Industries advanced an urban low-speed combined propulsion and levitation system (ROMAG) for which Boeing and, later, Carnegie-Mellon University acquired the rights. The Urban Mass Transportation Administration also funded follow-on research by Boeing into the development of this system.

Research sponsored by FRA led to the development of the linear electric motor, the motive power used by all current maglev prototypes. In 1974, a prototype LIM research vehicle set a world speed record of 255.4 mph at DOT's Transportation Test Center in Pueblo, Colorado.

Research sponsored by the National Science Foundation, with MIT, Avco, and Raytheon, produced a scale-model demonstration of a maglev concept called Magneplane. The Magneplane concept led to new possibilities for maglev, featuring enhanced maneuverability around curved guideways. The Magneplane approach is currently being revived under the auspices of Magneplane International, Inc. Other entrepreneurs have proposed maglev concepts for consideration as high-speed ground transportation systems, including new designs for the suspension and guidance/stabilization magnets.

In 1975, after Federal funding for high-speed maglev research in the United States was suspended, industry virtually abandoned its interest in maglev; however, research in low-speed maglev continued in the United States until 1986.

Current U.S. Interest in Maglev

The United States was among the world leaders in maglev research and development, sponsored in part by FRA through the mid-1970s; however, limited maglev technological research is underway in the United States at this time. While recent advances in superconducting technology have generated new interest in maglev systems, FRA discussions with industry representatives reveal that most believe high-temperature superconductivity is not a prerequisite for maglev feasibility. Industry representatives recognize that if U.S. companies were to develop the technology and manufacture advanced U.S. maglev systems for world markets, the benefits to the Nation could be substantial. On the other hand, industry is uncertain about future world markets and would benefit from more market research in this area.

During the 1980s, in response to growing interest by several States and large cities, the FRA funded several market feasibility studies of high-speed ground transportation. The studies, which considered both maglev and conventional high-speed rail, became the basis for current proposals to build and operate maglev systems.

In 1989, two reports on the benefits of developing maglev systems were issued; both have stirred interest in maglev. One, an Executive Report prepared by the Maglev Technical Advisory Committee to the Committee on Environment and Public Works of the U.S. Senate, stated that maglev technology using superconductors offers a uniquely attractive solution for U.S. domestic and worldwide needs, and that the United States should play a major role in its further development.³

The other report, written by Argonne National Laboratory and sponsored by the Department of Energy (DOE), suggested that if maglev systems were integrated into major airline hub operations, maglev systems could become economical in many high-density U.S. corridors.⁴ This would be particularly true if maglev systems also served city-center multimodal terminals and shopping complexes.

The U.S. private sector, including companies with potential roles in maglev development and manufacturing, recently has expressed interest in maglev technology. In particular, two separate organizations are promoting the idea of a development program for a U.S. maglev system. One group is "Maglev 2000," a coal-

ition formed in 1989 whose goal is to build and demonstrate a full-scale working prototype of a superconducting maglev system in the United States by the year 2000. Maglev 2000 is part of the broader based Council on Superconductivity for American Competitiveness, a group consisting of U.S. companies with an interest in superconductivity technology. Its membership includes large companies such as General Dynamics, Texas Instruments, Alcoa, Dupont, and Lockheed, and some smaller firms such as Intermagnetics General.

The second group is "Maglev USA," whose objective is to promote the development of U.S. maglev technology. This organization includes among its members General Electric, Grumman, and CSX Corporation.

At least one major construction company, Bechtel, is committed to maglev-related construction activity, and has formed a partnership with other companies in a bid to construct a maglev system between Las Vegas, Nevada and Anaheim, California. The interest of construction firms is understandable since the basic steel and concrete guideway structure comprises around 70 percent of maglev system capital costs.

At least one aviation executive, the president of U.S. Air Group, Inc., has suggested publicly that air carriers might be well-advised to get into the intercity ground transportation business as Lufthansa has done in Europe with rail service between airports and proximate cities. Finally, Amtrak has expressed an interest in becoming a contract operator of high-speed rail or maglev service, particularly if it interconnects existing city centers, Amtrak, or multimodal terminals.

U.S. Projects under Construction or Advanced Development

There are no maglev systems now operating in the United States. However, Maglev Transit Inc. proposes a project near Orlando that is most significant for the purpose of this report, because it involves a high-speed system capable of reaching at least 250 mph and would represent the first application worldwide of high-speed maglev technology in revenue passenger service. This system, based on West German technology produced by the Transrapid consortium, has undergone extensive testing at an experimental facility in Emsland, West Germany. The project, known as the Florida

Maglev Demonstration Project, is a privately funded proposed line connecting Orlando Airport with a terminal at a nearby resort area. It is expected to cost over \$450 million to build and would provide non-stop service on a single track between two terminals approximately 14 miles apart. Construction is scheduled to start in 1990 or 1991, and operations as early as 1994. The Florida project is viewed by many, including the developers of the technology, as a first step toward the implementation of a full-scale intercity corridor project and as a demonstration that high-speed maglev technology can operate on a daily basis with a high degree of reliability. The Transrapid technology is the same as that proposed for service between Las Vegas and Southern California.

There are also two low-speed maglev projects under development in Las Vegas; one project is under construction and another is in the proposal stage. The first is a people-mover now under construction in downtown Las Vegas by Magnetic Transit Corporation of America, a subsidiary of AEG, a West German firm involved with maglev technology. That project, privately funded, would result in a 1.3-mile system as its first phase. The Japanese HSST Corporation has proposed another 3.8-mile line in Las Vegas.

Current DOT Maglev-Related Activities

The Department's *Statement of National Transportation Policy*, issued in March 1990, identified six major themes to guide U.S. national transportation policy and to establish the agenda to meet the nation's long-term needs. The FRA initiatives described in this section are in consonance with these themes, particularly that of advancing "U.S. transportation technology and expertise for the 21st century."

FRA has broad authority over most aspects of maglev. The High-Speed Ground Transportation Act gives FRA authority to conduct research, development, and demonstration of all forms of high-speed ground transportation, including maglev. The Rail Safety Improvement Act gives FRA responsibility to regulate maglev safety.

As the agency responsible for the safety of maglev systems, FRA is involved in several maglev activities. FRA has initiated a major safety research and evaluation effort. Safety-related research on the West German Transrapid system, the system proposed for demonstration in Florida in the near future, is underway and is being accelerated so that work on safety standards does not impede implementation of the system. This work will evaluate the adequacy of the existing West German safety standards for the maglev system, the compliance of the system with these standards, and the need for additional standards for operation in the United States.

This initial safety research focuses on Transrapid and attractive maglev technology because it has been formally proposed for use in the United States. Repulsive levitation technology will also be covered by the FRA research. The FRA will work with the developers of maglev systems to ensure that FRA safety standards are clear and timely and that they are incorporated into the system design.

DOT is also assisting the Florida High-Speed Rail Transportation Commission officials and the developers to explore the environmental issues related to the proposed Florida maglev project. The FRA will serve as the lead agency for preparation of any Federally required environmental documentation. This type of assistance will be provided to other project sponsors and other State commissions as needed or requested.

Chapter Two

The Current State of Magnetic Levitation Technology

Overview of Current Technology

The possibility of using magnetic forces to levitate vehicles has fascinated inventors for nearly a century, but only recently has the technology become practical for high-speed ground transportation. The original concept, proposed in the early 1900s, was based on the attraction of permanent magnets on a vehicle to ferromagnetic plates on a guideway. The concept was determined impractical without some way to control the magnetic fields for stabilization. In 1933, Hermann Kemper, in Germany, mastered the control problem with the use of electromagnets so that a constant air gap could be maintained between the electromagnet and the ferromagnetic plate.

Maglev technology is used to accomplish three primary functions, as illustrated in Figure 1: (1) levitation or suspension; (2) propulsion; and (3) guidance. Magnetic forces can perform each of these functions, although a non-magnetic prime mover could be used for propulsion. Over the years, researchers have explored not only alternatives in the three functional areas but also various combinations of options in each functional area. There is no consensus within the engineering community, today, on an optimum design to perform each of the primary functions.

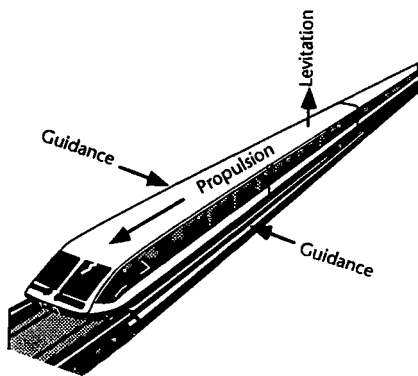

Figure 1. The Three Primary Functions Basic to Maglev Technology

Suspension Systems

Current maglev research and development efforts have concluded that three types of systems can provide magnetic forces suitable for vehicle levitation: electromagnetic suspension (EMS), electrodynamic suspension (EDS), and permanent magnet suspension (PMS). The EMS and EDS systems are generally regarded as the most advanced for high-speed ground transportation. With advances in permanent magnet materials, however, PMS may become a viable candidate for high-speed maglev applications.

Electromagnetic Suspension (EMS)

In the EMS, or attractive force maglev suspension system, electromagnets on the vehicle interact with ferromagnetic guideway rails. In the current application of the EMS concept, as shown in Figure 2, the vehicle underframe, which wraps around the guideway, draws the vehicle up (i.e., "attracts") to approximately 8 millimeters (3/8 inch) from the rails. Electromagnets located along the sides of the vehicle provide guidance.

The electromagnetic current must be controlled to keep the system stable. Otherwise, as the gap between the vehicle and the rail diminishes, the force of attraction between the vehicle electromagnets and the ferromagnetic guideway increases until the vehicle and the rail come

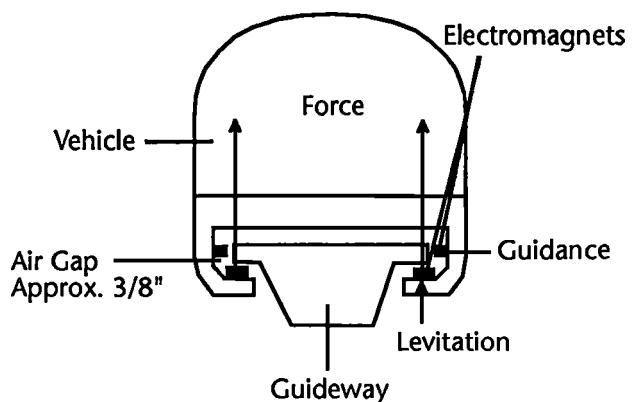

Figure 2. Electromagnetic Maglev

together. An active gap-control system that incorporates an air-gap sensor is required to adjust the current through the electromagnets to maintain a constant air-gap distance between the guideway and the vehicle.

EMS was made practical by advances in electronic control systems, which control the air gap rapidly, and make higher speeds possible. Variations in payload weight, dynamic loads, and guideway irregularities are compensated for by adjusting the magnetic field according to vehicle/guideway gap measurements. With EMS, vehicles are able to levitate at zero speed. The current EMS design also includes a secondary suspension to ensure good ride quality.

EMS systems have been investigated in a number of countries, including Great Britain, West Germany, Japan, Romania, and the United States. In most cases, these research programs terminated long ago. However, West Germany and Japan have continued developing EMS systems over the past two decades.

The West German and Japanese EMS systems are now nearing commercial application. Only the West German system, Transrapid, however, is a high-speed system, capable of speeds of more than 250 mph. Transrapid has been developed by a consortium of West German companies with a combination of private funds and grants from the West German Ministry of Research and Technology.

Electrodynamic Suspension (EDS)

When a magnet moves relative to a surface or material that conducts electricity (a "conductor"), it generates an electric current in the conductor. EDS systems use this electromagnetic phenomenon with superconducting magnets (SCMs) on the vehicle interacting with guideway conductive sheets or coils. The current induced in the guideway reacts with the original field to repel the magnet (i.e. the vehicle). EDS is usually referred to as repulsive force maglev. This technique has progressed as a practical concept with advances in superconducting magnet technology along with cryogenic (cooling system) technology needed to keep the materials at a temperature low enough to permit the superconducting effect. Two Americans, Dr. Gordon Danby and Dr. James Powell, both of the Brookhaven National Laboratory, proposed and designed the first EDS system concept in 1966.

In the current application of the EDS concept, the induced current in the conducting guideway suspends the vehicle 10 centimeters (4 inches) or more above the guideway, as shown in Figure 3. With EDS, as distance between vehicle and guideway decreases, the magnetic repelling force increases, making the system inherently stable. However, since the superconducting magnets must move with respect to the conducting plane to generate the repelling force, the EDS will not levitate at speeds below 40 km/h per hour (25 mph). Therefore, the vehicle must be equipped with wheels for "takeoff" and "landing." Its low stiffness, or soft suspension, may make it necessary to provide an active damping control system for stabilization to meet ride-quality standards.

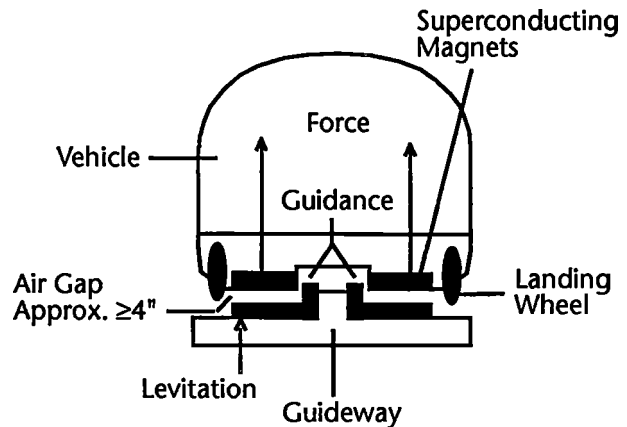

Figure 3. Electrodynamic Maglev

As noted above, the EDS system uses SCMs. A superconductor is a material that offers no resistance to the flow of electricity, thus permitting transmission of strong, constant current, without loss of energy in the form of heat. In the past, materials used as superconductors had to be cooled to the vicinity of absolute zero (-459.7 degrees Fahrenheit or -273.2 degrees Centigrade) to achieve superconductivity, requiring the use of liquid helium as a cooling medium. Recently, scientists have found materials in which superconductivity can be achieved at higher temperatures, allowing the use of liquid nitrogen, a far cheaper and easier substance to handle. While not yet perfected for use in maglev systems, the availability of higher temperature superconducting materials would enhance the economics of EDS technology and may find applications in EMS-type systems as well.

Under the direction of the Japanese Railway Technical Research Institute (RTRI), which took over design responsibility from Japanese National Railways (JNR) in 1987, Japan has used the EDS approach in developing designs for its superconducting trains. The initial Japanese efforts were funded by the national government. National and local governments, as well as the newly privatized railroads, are funding the current efforts.

Permanent Magnet Suspension (PMS)

PMS may be configured as either attractive or repulsive maglev, using permanent magnets instead of electromagnets or superconducting magnets. In a PMS system, magnets on the vehicle interact with either guideway permanent magnets, guideway ferromagnetic rails, or induced current in guideway conductive sheets or coils. Recent improvements in permanent magnet materials and progress in developing superconducting permanent magnets have increased the potential for their use. The use of PMS for low- to medium-speed revenue-service maglev has been developed by West Germany's Magnetbahn GmbH (M-Bahn), a subsidiary of AEG, Frankfurt. Additional PMS systems have been proposed that would extend the upper speed range of PMS maglev. At this time, however, PMS systems do not offer the potential for the relatively high speeds being achieved with the EMS and EDS suspension systems.

Propulsion System Options

Maglev propulsion schemes fall into three classes: (1) the on-board prime mover; (2) the "short-stator" (vehicle-mounted) linear motor powered by wayside electric power rails or lines; and (3) the "long-stator" (guideway-mounted) linear motor powered by an electrical guideway. The on-board prime mover (motor and energy source onboard the vehicle) offers the most straightforward solution to propulsion but results in heavy vehicles and reduced operating efficiency because of the weight of the on-board energy source. Prime movers, such as gas turbine or turbo-prop engines, might be noisy and, in most cases, would require on-board fuel, which could present safety and emission control problems. Prime movers also could entail substantially higher maintenance costs because of engine complexities.

Propulsion using short-stator design and either a single-sided or double-sided linear-induction motor (LIM) in the vehicle, on-board electro-magnetics, and a passive guideway, compared with systems using propulsion mounted on the guideway, has greater promise because of its comparatively lower guideway cost. Presently, this saving is offset by the need for wayside power pickup, higher vehicle weight, greater energy consumption, and higher operating costs compared with the long-stator system. The HSST Corporation of Japan operated a short-stator maglev in Yokohama at speeds from 0-80 km/h (0-50 mph). A German-French consortium, formed to develop the STARLIM, a maglev system combining EMS suspension with LIM propulsion, illustrates the continued interest in the short-stator system.

Long-stator propulsion with an active (powered) guideway appears to be the most favored option for high-speed maglev today. It is also the most expensive because of its higher guideway construction costs. However, it has the advantage of reduced vehicle weight and increased vehicle payload efficiency. West Germany and Japan use the long-stator motor for their high-speed maglev propulsion systems.

Guidance Systems

Guidance or steering refers to the sideward forces that are required to make the vehicle follow the curves and straightaways of the guideway. The necessary forces are supplied in an analogous fashion to the suspension forces, either attractive or repulsive. The same magnets on board the vehicle which supply lift can be used concurrently for guidance, or separate guidance magnets can be used.

Drs. Danby and Powell developed the "null-flux" concept, which has important implications for vertical and lateral vehicle stabilization. In its present application, the null-flux system uses figure-eight coils attached to the guideway, which interact with magnetic fields produced by the vehicle's superconducting magnets to support the vehicle, maintain its alignment, and ensure its stability. This concept has been incorporated into the design of the Japanese high-speed maglev system.

Chapter Three

Technical Feasibility

The preliminary analysis conducted to date suggests that the use of maglev in the United States is technically feasible. However, no firm conclusions can be drawn regarding the appropriate U.S. role in future maglev development until further detailed analysis can be conducted. This chapter addresses the opportunities for U.S. maglev technology development and the technical issues requiring further study that influence these U.S. development opportunities.

Both the EMS and EDS systems appear suitable for U.S. application. At the current level of development, EMS appears to have several advantages, including a high-speed prototype demonstrating good ride quality, off-line switching capability, and very low magnetic field levels. It has operated safely during a long prototype testing program and appears ready to be implemented. There is more experience with ride quality and switching capability on the EMS system. However, EMS vehicles are heavier than EDS vehicles and appear to require more power per seat-mile. Also the smaller maximum separation between vehicle and guideway of the EMS requires more precise guideway alignment and vehicle control, potentially leading to higher cost. The current designs of both systems use long-stator motors, which employ an actively powered guideway. Both systems are very promising, but more research is required to determine which, if either, would offer the better basis for development of a U.S. system.

Magneplane should also be considered for further study. It uses an EDS system, but based on cylindrical geometry, it is designed to roll about its main axis, stabilized by a magnetic keel which, its proponents say, will allow it to negotiate curves effectively. With Magneplane, the superconductor could be a hollow tube with coolant in the middle which, in turn, could lead to a more efficient cooling/conducting system.

Among the maglev system concepts already developed, the German Transrapid system is the closest to commercial implementation. It is possible, however, that a less developed system, or even one that is yet to be proposed, will turn out to possess the best combination of performance and economics for use in the United

States. Even if a demonstration Transrapid system is built, it does not preclude the possibility that a second- or third-generation maglev design would become the predominant system in the United States and elsewhere. The use of common intermodal terminals would make the use of one system design less critical.

U.S. Maglev Technology Development Opportunities

Many opportunities exist for further development of maglev technology that could result in significant increases in technical effectiveness. Unless otherwise indicated, these opportunities are common to both EMS (e.g., German Transrapid) and EDS (e.g., Japanese Railway Technical Research Institute) systems.

Guideway Structure

Fixed facilities account for about 90 percent of total maglev capital costs (exclusive of land). The guideway structure represents, by far, the largest single element, perhaps 70 percent, of these fixed-facility costs. In a recent maglev forum of Government and industry officials (May 2-3), several ideas were presented for improved materials and designs for the beams and foundations that comprise an elevated guideway. Additionally, new, stronger, and lighter space-age construction materials, new computer-aided design and manufacturing procedures, and new ideas for lighter weight vehicles versus those built in Germany and Japan could have a major influence in reducing guideway costs. Any significant reduction in these costs would have a proportional effect on maglev economics.

Right-of-Way

Because the United States has already invested in an extensive network of Interstate and other highways and the railroads have developed privately financed railroad lines linking major population centers, there are many routes between major points that potentially could be served by maglev systems. The opportunity exists for employing these existing rights-of-way and air rights for a dual purpose without interfering unduly with their original function.

The potential for using existing rights-of-way, however, requires further investigation. Interstate highways were designed for maximum speeds of 70 mph and have curves and clearances that may not be suitable for higher maglev speeds. Similar issues confront the use of railroad rights-of-way.

An evaluation of the practicality of using existing rights-of-way should be conducted. The study should assess not only the engineering but also the practical implications of constructing and operating maglev alternatives on existing rights-of-way to evaluate which systems are best suited for such applications. This assessment must consider the speed limitations related to alignment; the financial and aesthetic effects of locating an elevated maglev on the existing rights-of-way; and the compatibility of maglev systems with their existing users, in particular, compatibility with motor-vehicle operations or conventional railroads.

Propulsion System Innovations

The windings of the long-stator motor employed by the German Transrapid and Japanese EDS maglev systems run the length of the guideway and are a major element of system cost. Significant opportunities may exist for reducing this cost through improved magnetic design of both the vehicle magnets and the guideway windings.

Alternative propulsion concepts using on-board prime movers such as the ducted turbofan engine or short-stator LIM might reduce capital cost. Ways must be found to mitigate the environmental effects and safety issues of the fan, to reduce LIM weight problems and to control vehicle operating and maintenance costs.

High-Temperature Superconducting Magnets

Although low-temperature superconductors do not pose the feasibility problems that were expected before the Japanese made significant strides in cryogenic systems, high-temperature superconductors would likely be used in EDS systems when they become available. Hence, maglev technology represents a very important potential commercial market for these materials. Economic feasibility of maglev systems could be enhanced by the availability of high-temperature superconductors.

Magnetic Field Exposure

EDS maglev systems employ large magnetic fields to suspend the vehicle. Although static magnetic fields have not been shown to pose any health hazard, the issue is not closed and could affect the feasibility of certain maglev designs. Magnetic fields can be reduced to inconsequential levels by magnetic shields, but the shields are complex and add weight. At the Government/industry maglev forum, a design concept was presented for efficient magnets that confine the magnetic field to the suspension region with minimal shielding.

Improved Stabilization

Passenger comfort is essential for consumer acceptance and to assure that maglev systems win and keep a sizable share of the transportation market. Further study should be devoted to identifying efficient systems for reducing vertical and lateral accelerations experienced by passengers. Consumer reactions to these forces also need to be better understood. EDS systems present the opportunity for substantial improvements in this area.

Better Cryogenic Systems

An efficient cryogenic system is one of the key elements in advancing the EDS technology. Lack of a suitable low-temperature lubricant causes excessive component wear in current compressors, and compressor life is regarded as unacceptably short. There appears to be an opportunity to improve the reliability and/or to reduce the cost of the existing helium compressors used in these systems.

Maglev Technology Spinoff

Maglev appears to offer significant opportunities to advance other high-technology industries in this country. Although quantifying the external investment benefits of a new technology is elusive and estimates of these benefits are beyond the scope of this report, maglev technology spinoffs will influence other U.S. industries. Improvements in semiconductors for maglev power delivery could find applications in power plants and other transportation systems. Advances in computer-integrated design, fabrication, and assembly of maglev vehicles and guideways could be translated to other industries. If an EDS system is favored, significant advances in superconductivity and its commercial applications can be expected—in computers, advanced electronics, medical

diagnosis, electric motors, and magnetic separators.

Operational Considerations

The ability to switch vehicles safely at high speeds and the related possibility of serving intermediate stations without impeding traffic on the main line can greatly increase the attractiveness of maglev systems, compared to air service. For U.S. maglev systems, high-speed switching appears to be one of the most important operating challenges, but switches are also among the least developed components, particularly for EDS.

Some argue that a U.S. maglev system should depart from traditional high-capacity, multicar trains used in conventional high-speed rail systems that serve a limited number of intermediate points. The alternative is a system that has frequent—to a large extent—non-stop service by single cars to many more origins and destinations. Such a change would have major implications for system design. The high-capacity design would require a guideway capable of supporting heavier car loads but would have a limited network of these guideways. The guideway for the single-car concept may not need to be as strong (and expensive) because of its lighter loadings, but additional miles of guideway would be required to serve a greater number of points off the main line. Further study is needed to establish the relative desirability and effectiveness of these approaches.

Its high surface speeds, system capacity and competitive trip times are the major attractions of maglev. The sensitivity of maglev ridership to different speeds and the door-to-door trip-time capability of different maglev designs must be analyzed. Similarly, the implications of high speed on concerns such as energy consumption and aerodynamic noise must also be examined.

Safety and Reliability

Safety and reliability are not so much opportunities as they are absolute requirements in any new system that hopes to compete with other forms of transportation. The Transrapid developers, for example, have taken elaborate steps to assure safety. The zero fatality records of the 25-year-old Japanese bullet train and the nine-year-old French TGV-train on exclusively high-speed tracks are testimony to the care given to

safety of high-speed ground transportation systems. The U.S. effort must be able to demonstrate to the public that safety and reliability are inherent features and that safety is an overriding requirement in the design process.

To this end, the FRA is already taking steps to assure the safety of existing maglev systems through research and test monitoring that will lead to the development of regulations. In addition, as part of any future research and development on a U.S.-maglev system, particular attention will be given to the safety of control systems; emergency egress; fire and other hazard detection; vehicle and guideway maintenance standards; and other safety-related issues. In other words, safety will be designed into the system from the start.

Development Strategies

Several options and approaches regarding development strategies are already evident. The maglev industry is in its late infancy and many opportunities exist to participate in its further development. The potential also exists for U.S. industry to play a leadership role in that development.

Two principal options must be considered in deciding how the United States might exploit maglev-development opportunities. The first is for the United States to proceed rapidly on its own with a new design attempting to leapfrog existing technology. The second involves a commercial arrangement or joint venture with the overseas developers of an existing maglev system that would permit incremental improvements. A significant sector of industry believes that improving on existing maglev technology and focusing on the aspects that most affect mass production cost—the guideway and associated construction technologies—is more prudent than “re-inventing the wheel.” Other opportunities may become apparent as research in advanced American maglev systems progresses.

A third approach is to import systems from Germany or Japan. This approach has certain advantages, including earlier implementation and low financial risks. The downside is that U.S. participation would be as a contractor and customer with few of the advantages of a partner/owner. Moreover, the U.S. could miss out on many of the technical spinoffs and benefits from the continuing development of maglev vehicles and high-technology guideway

equipment such as linear motors and power supplies. However, the U.S. construction industry would still benefit from increased construction activity.

While an evaluation of these alternative development strategies is clearly required, they must also be viewed in the contextual framework of U.S. industry capabilities, availability of industry resources, and industry willingness to participate in maglev technology development. U.S. industry believes that the market is too uncertain to warrant spending its very scarce research and development funds or to commit significant resources to cost sharing. Measures to support U.S. leadership in maglev technology and to stimulate industry involvement are the subject of Chapter Five.

Technical Issues Requiring Further Investigation

The President's Fiscal Year 1991 budget request identified a need for further studies on maglev technical feasibility. Of the many areas highlighted, seven issues warranting further investigation are listed below:

- Whichever approach is ultimately selected, an aggressive effort is needed to evaluate and develop options for reducing guideway costs. A reduction in guideway structure costs would have a proportionate impact on the financial viability of maglev systems since such costs represent a large percentage of capital costs. This research effort should consider improved, lighter materials, and designs for beams and foundations. Innovative design, fabrication, and construction methods should also be considered.
- A comprehensive study is needed of the design and construction of maglev systems using existing rights-of-way. The study should examine physical compatibility as well as human factors related to the limits of such usage.
- Alternative propulsion options should be studied. The pros and cons of using the short-stator motor should be included as an important aspect of this analysis.
- Operational considerations should be analyzed to determine which configurations of maglev systems are suitable for the United States, addressing such issues as vehicle configuration and service frequency. The impact of on-line versus off-line stations should be one focus of the analysis.
- Operating speeds should be examined to assess trade-offs between achieving shorter trip time versus higher costs. Other pertinent factors such as energy consumption, the environment, and the ultimate transportation advantages to be gained by an investment in maglev should also be examined.
- Magnetic fields produced by superconducting EDS systems decline rapidly with distance, but fringing fields can reach the passenger compartment. These fields can be reduced with shields, but shields are complex and add weight. Both the techniques for designing efficient magnet configurations, which confine the fields to the suspension compartments and do not reach passenger areas, and materials for shielding passenger-carrying areas should be studied.
- A detailed study is needed on the approach to the development program and the development of the technology itself. Alternative approaches to a maglev development program should be evaluated on the basis of the potential costs and benefits to the United States. There is much to be said for a program leap-frogging existing technologies, but leap-frogging is only one of three options that should be evaluated. The second option would involve an arrangement with the developers of existing prototypes that would permit incremental improvements. The third option is to import existing maglev systems from Germany or Japan for implementation.

Chapter Four

Economic Feasibility

Maglev can find a variety of applications for moving people and packages in the United States, using one or more of the potential technologies and a variety of configurations to serve different markets. Cost and performance characteristics combined with demand and financing considerations will be critical elements in determining the course of maglev development.

Maglev technology could be used for specialized low-speed people movers, urban rapid transit systems, or high-speed intercity ground transportation. At the high-speed end of the spectrum, with speeds that can exceed 300 mph, maglev could be used to serve markets where commercial travel is dominated by airline service.

High-speed maglev systems can be used in the following configurations:

- *Intercity corridor* services of 100 to more than 500 miles between end points serving metropolitan areas along a single route with stations at selected points in downtown multimodal terminal or suburban activity center locations.
- *Intercity corridor/airport* services, similar to intercity corridor, but with stations or branches serving selected airports.
- *Intercity networks*. Combinations of intercity corridors serving downtown locations, suburban locations, and selected airports, with service provided between any two stations in the network.
- *Short-distance connections*. Connections between a downtown terminal and a major suburban center, between a downtown multimodal terminal and an airport, or connecting airports in the same metropolitan area. (This concept is not analyzed in this report, but has been proposed in several U.S. locations including Orlando and Pittsburgh.)

Since the emphasis in this report is on high-speed maglev systems, the analysis of economic feasibility concentrates on intercity and airport network applications, where longer distances between most stations permit maglev to take

advantage of its higher speeds. Such systems offer the potential to improve dramatically intercity mobility in certain markets.

Previous U.S. Studies

One indication of potential economic feasibility in the United States comes from previous studies. These studies have focused almost entirely on intercity corridor systems. Examples of intercity corridors for which maglev has been considered include:

- Las Vegas/Southern California
- Miami/Orlando/Tampa
- Fort Worth/Dallas/Houston
- Cleveland/Columbus/Cincinnati
- Philadelphia/Pittsburgh
- Chicago/Detroit
- Vancouver/Seattle/Portland

In these studies, conducted between 1982 and 1988, maglev systems and high-speed rail systems were evaluated in terms of performance, net operating revenues, and capital-cost coverage. Generally, all these studies concluded that both maglev and high-speed rail revenues can cover operating costs and contribute to capital-cost amortization in varying degrees, although they may not necessarily achieve complete capital-cost coverage. Until recently, maglev technology had not been considered ready for implementation. Consequently, most of the studies factored this view into the recommendations.

Among the U.S. corridor applications, the Las Vegas/Southern California corridor has given the most detailed and lengthy consideration to maglev. The final report on this corridor, published in 1986, included consideration of both maglev and high-speed rail, using the German Transrapid and the French TGV technologies, respectively, as specific examples. The report concluded that, in both cases, revenues would be sufficient to cover operating and capital costs. Since that time, a bistate commission was established to conduct

a franchise competition process involving potential applications based on maglev technology or high-speed rail. Three consortia have expressed major interest. The Bechtel Corporation has publicly stated that it considers Transrapid a finished product and that it will bid for the franchise on the basis of Transrapid maglev technology.

The final report of the feasibility study for the Philadelphia/Pittsburgh corridor, prepared by a State commission, recommended a maglev system linking Pittsburgh and Harrisburg, with transfers to an improved rail-line connecting with Philadelphia.

More recently, Maglev, Inc., an organization led by Carnegie Mellon University and a group of Pittsburgh-area industries and organizations, conducted a feasibility study on starting a maglev supply industry in the area and building a regional maglev system, beginning with a demonstration project connecting the airport with a downtown multimodal terminal. The group determined that although the demonstration project would not pay all capital and operating expenses from farebox revenues, the group would pursue the overall project because of the U.S. potential for maglev and its potential contribution to economic growth in the Pittsburgh area.

Economic Analysis of U.S. Maglev Potential

This analysis includes a broad look at the potential economic feasibility of maglev systems, including the broad economic implications as well as the financial feasibility of development, construction, and operation of maglev systems. The analysis considers whether it is likely that project revenues from users over the long term will cover projected costs. Some projects may also be considered feasible if initial development and capital costs are offset in part by public-sector contributions which may be shown to be justified by public benefits. Both types of results are discussed—projects estimated to cover all their costs and those needing public-sector support.

External benefits considered in this report include anticipated environmental advantages of maglev, reduced dependence on petroleum-based fuel, and avoidance of the cost and disruption of expanding the facilities of other transportation modes. Other benefits of investment in maglev technology include technological spinoff into other industries

benefiting from maglev research and development.

The principal questions addressed by the analysis were:

- What is the extent of possible maglev routes where net passenger revenues (i.e., net of operating costs) are likely to be sufficient to finance total capital costs?
- Where capital costs cannot be financed by net passenger revenues, are there external benefits on some routes that may justify public financing of capital costs?

To answer these questions, city-pair markets generally less than 500 miles apart and with heavy air travel were identified, hypothetical maglev networks were assumed to serve these markets, and the future travel between these cities and the future maglev market share were estimated based on the service characteristics of maglev versus competing transportation modes. Costs, revenues, and public benefits associated with each portion of the network were calculated and compared. Revenues and costs are in 1988 dollars.

The analysis did not attempt to quantify non-user revenues such as from value-capture of adjacent land development or from impact fees levied on nearby property owners to finance a maglev project. For example, in Florida, financing the proposed 325-mile high-speed rail system linking Miami, Orlando, and Tampa will depend largely on revenues from real estate development related to the rail project. Revenues derived from commercial development near multimodal terminals could make a project profitable, even if the project could not generate sufficient revenues from the project fares to cover the capital and operating costs.

This report does not contain an analysis of maglev versus high-speed rail or other solutions for intercity transportation. This will be left to later studies.

The factors considered and the assumptions used in the analysis are summarized briefly in the following sections.

Maglev Markets Considered

Primary consideration was given to earlier described city pairs. Additional city pairs were considered for hypothetical maglev service, including certain markets recently studied for

the feasibility of high-speed rail service, and several other important regional air travel markets. This initial list formed the basis for constructing routes or networks permitting maglev travel between hypothetical station pairs, including major hub airports. The networks analyzed in this process are shown in Figure 4 as solid lines.

The projections in the report cover only regional systems, since maglev systems are most likely to evolve on a corridor or regional basis. In the longer term, it may be desirable to link these regional networks. Both the Interstate Highway system and the Nation's airport system are examples of infrastructures built largely by the public sector, but effectively financed by fees raised from users—essentially private companies and their customers (passengers and shippers) and automobile and truck owners, with some Federal general-fund contributions.

In the long term, an even more extensive system of national scope might be possible. A more careful study would be needed to determine routings and priorities.

Future passenger travel in each market was projected on the basis of population and income growth forecasts. Maglev's market share was estimated using a technique based on relating the market share of each mode to the relative attractiveness of the service provided. A detailed discussion of passenger forecasts is provided in Chapter IV and Appendix IV-A of the Report Supplement.

Future Maglev Revenues and Costs

It was assumed that average maglev fare in any given city pair would be the same as the 1988 average airline fare, that is, the average fare

EXAMPLES OF MAGLEV NETWORKS

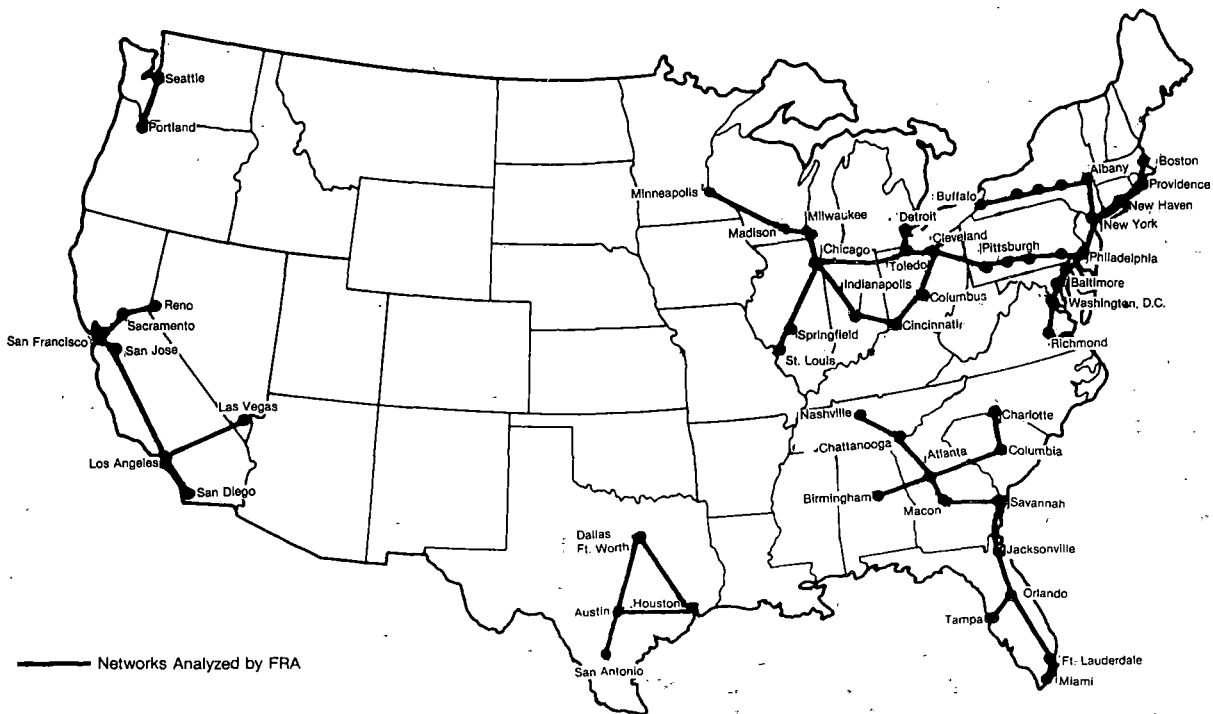

Figure 4. Examples of Maglev Networks

taking into account all the discount fares used by air travelers. To estimate revenue, the fare in each market (average 1988 airline fare) was multiplied by the number of estimated maglev passengers in that market.

Operating and Maintenance Costs

The assumptions used in this report on maglev operation and maintenance cost were taken from reports prepared by the Canadian Institute of Guided Ground Transport (CIGGT), under contract to the Department of Super-Speed Train Development, City of Las Vegas, Nevada. An assumption of 5 cents per passenger-mile was used. A detailed discussion of these costs is included in the Report Supplement.

Capital Costs

High-speed ground transportation systems are very capital-intensive, particularly in terms of the cost of fixed facilities. It is extremely difficult to project the capital costs of a technology that has not yet been developed, such as a maglev system based on a U.S.-designed and built product. As a starting point, cost estimates furnished by West Germany's Transrapid International and independently derived estimates of the cost of certain guideway components were used to estimate capital costs. Two points must be emphasized:

- Capital costs—especially guideway costs—are highly dependent on the location of particular projects, the nature of the terrain and soil conditions, and the degree of urbanization.
- The cost of a U.S.-designed system could be significantly different from the cost based on the existing technology. Specifically, a major emphasis is likely to be placed on ways of reducing the guideway costs in any U.S. development program, and this could reduce the capital costs significantly.

Fixed Facilities Costs

For most potential maglev corridors, a fixed-facility cost of \$16.5 million per mile was used, assuming a single-track guideway and including passing sidings sufficient to accommodate headways of one-half hour between vehicles in each direction. In maglev routes of about 850 miles in length—primarily in the Northeast Corridor and on the West Coast—a double-guideway would be needed if departures were scheduled at less than half-hour intervals in the first year of operation. On these routes,

fixed facilities would cost an estimated \$30 million per route-mile, reflecting the cost of a double guideway. Along another 780 miles of route, a double guideway would probably be required during a 30-year period after the first year of operation. This cost was taken into account in the calculation by adding the incremental cost of the second guideway at a future point and calculating the net present value of that cost.

Vehicle Costs

Information provided by Transrapid shows the cost of an 80-seat vehicle would be approximately \$3.6 million. The report's calculations (described in the Report Supplement) estimate that with a 63 percent load-factor (typical of Metroliners and domestic air carriers), such a vehicle could produce about 26.4 million passenger-miles per year. The report calculates vehicle cost by dividing passenger-miles by 26.4 million, then multiplying by \$3.6 million, and adding a factor to reflect the net present value of future vehicle capacity over a 30-year project life. For most highly used routes, the vehicle capital cost represents only about 11 percent of total capital cost. For less heavily used routes, the percentage of capital cost is less.

Land Costs

Land costs have not been explicitly included in the analysis because, more so than guideway costs, land costs are highly dependent on the particular routing, including the extent to which it is possible to use existing rights-of-way at little or no cost. Use of Interstate and other highway rights-of-way for maglev systems has been advocated as a way to minimize the amount of new rights-of-way and the cost required to construct a maglev system, and to avoid environmental disruption that could result from the creation of a new transportation corridor. Many Interstate highways were built on rights-of-way that included margins of land between the edge of the roadway and the right-of-way boundary sufficient to accommodate a maglev system. In some locations, however, such as rapidly growing urban areas, any originally unused rights-of-way have been committed to highway expansion or other transportation uses.

An analysis of the nature of Interstate rights-of-way in transportation corridors considered in this report showed that maglev systems confined exclusively to Interstate Highway alignments would in many cases suffer serious

speed penalties because of the presence of curves.

A hypothetical 60-foot-wide double track maglev corridor equals approximately 7.5 acres per mile. A cost of \$10,000 per acre (a very high figure for strictly agricultural property) equates to only \$75,000 per mile, very low compared to fixed-facility and vehicle costs. Exurban/suburban values of \$100,000 per acre for raw land would still equate to only \$750,000 per mile, or less than 5 percent of fixed facility costs. Estimating the cost of acquiring improved property in an urban setting is a case-by-case matter. In general, the dominant force regarding right-of-way costs in urban areas will be the presence or proximity of buildings, not the land area to be acquired.

Where the alignment is appropriate, existing rights-of-way could limit the need for new right-of-way acquisition. However, the analysis emphasizes that decisions on right-of-way use can be made only on a case-by-case basis.

Public Benefits and Costs

The current reliance on highway and air travel results in substantial external costs: in the form of high energy consumption, land taken from other uses to provide air and highway facilities, air pollution, and, in the case of highways, a relatively high rate of fatal accidents. Maglev service would also involve some external costs, such as new rights-of-way for guideways but, compared to air and highway transportation, the noise effects, air pollution (sulfur dioxide emissions at electricity generating facilities), and energy consumption would be minimal.

Taking into account traffic diverted from the air and highways, a passenger-mile of maglev use represents savings of about 2,100 British Thermal Units (BTUs) of energy. A maglev system comprised of routes whose estimated revenues would cover their estimated costs would save between 17.5 and 33.6 trillion BTUs of energy per year, depending on whether unfavorable or favorable assumptions were made in projecting revenues and costs. Since maglev energy is derived from electricity, which is principally generated using non-petroleum fuels, the savings in *petroleum* energy from diversions of highway and air travel would be 45 to 86 trillion BTUs, or 7.7 to 14.8 million barrels of petroleum per year. Although this is a substantial amount, it represents only a very small fraction of U.S. petroleum consumption.

For the same routes, a total of 58,000 to 109,000 tons of carbon monoxide (CO) emissions per year would be eliminated. For nitrogen oxides and volatile organic compounds, the reductions from transportation sources would be from 14,300 to 27,500 and from 9,800 to 18,800 tons, respectively. These represent very small percentages of pollution from transportation sources. Regional or corridor impacts on fuel consumption and pollution are likely to be greater in percentage terms. Further research is needed to evaluate these issues.

Maglev links can reduce the need for some public spending for additional airport and highway capacity. Assuming that 15 percent of maglev passenger-miles are new, non-diverted trips and half of the remainder come from auto and the rest from air, this would represent a diversion of 3.5 to 6.8 billion passenger-miles from highways, and 20 to 38 million airport passengers. These auto diversions are estimated in this report to equate to the need to provide fewer highway lane miles, while the air diversions could save money spent on airports. For the routes estimated to cover all capital and operating costs from fares, a one-time savings in capital investment costs (substantiated in the Report Supplement) were calculated at \$3.5 to \$7 billion.

The foregoing discussion pertains to public benefits associated with routes where revenues are estimated to be sufficient to cover operating costs and at least 100 percent of capital costs. Public benefits would be significantly greater if more extensive systems were built, such as all systems which covered operating costs and at least 50 percent of capital costs. Maglev passenger-miles on those routes would be about double the passenger-miles on routes that cover 100 percent of costs from fares and public benefits would also be about twice as great.

Conclusions of the Economic Feasibility Assessment

The results of the economic and financial analysis need refinement, based on more precise answers to questions about markets, market share, future travel growth, costs, and technology. This caveat notwithstanding, the conclusion derived from this preliminary analysis is that it will be economically feasible to construct a limited number of commercial maglev systems in the United States, starting in

this decade. The specific findings of the analysis are:

- Relying solely on net user revenues, and assuming the availability of adequate rights-of-way at little or no cost, it appears possible to finance from 500 to 2,600 route-miles of maglev lines in the United States (with a total of 1,000 to 3,500 miles of single-track guideway and passing tracks) on a project-by-project basis, without recourse to public finance, but assuming access to tax-free bond financing for a substantial portion of the capital. (See Chapter Five on the availability of tax-free bonds under current law.)
- The construction of these lines would represent \$15.2 to \$54.7 billion in fixed-facilities expenditures, including basic structures and the sophisticated support equipment needed to power and control the trains.
- About \$1.2 to \$3.2 billion in vehicles would be needed to carry passengers on these lines at the start of service. This amount would increase to \$1.8 to \$5.2 billion over the initial 20-year period of operation, if only those lines estimated to cover 100 percent of capital and operating costs from fares were built.
- Some form of external revenue generation, such as enhanced real estate value-capture or public financing, is needed for projects beyond this initial mileage. Based on the assumptions described earlier in this chapter, it is estimated that about 1,500 to 5,000 route miles (2,300 to 6,300 miles of single guideway) would yield enough net revenues to cover all operating costs and repay at least 50 percent of capital costs. These projects would represent from \$35 to \$97 billion in fixed-facility expenditures and \$2.3 to \$4.2 billion in vehicles (\$3.7 to \$6.8 billion over 20 years).
- Substantial savings in public-sector infrastructure costs (reduced highway and airport capacity to serve increased travel demand) could be used to justify public investment in maglev projects.
- Other significant public benefits accrue from reduced dependence on petroleum energy sources and reduced air pollution.

A sensitivity analysis of the findings to varying assumptions suggested the need to consider

a number of alternative future scenarios regarding cost and maglev service. The top and bottom ranges of route mileage estimated to cover all their costs from fares and of public benefits in the preceding discussion represent favorable and unfavorable assumptions—or scenarios—about costs and maglev traffic.

On the capital cost side, the results were not significantly sensitive to variations in vehicle costs. This is understandable since vehicle costs represent only about 10 percent of capital costs. As to fixed-facility costs, it is expected that improved construction methods will result in reduced construction costs. The estimates of capital costs did not include any cost for right-of-way acquisition or extraordinary structures such as tunnels. Such costs could more than offset the expected reduced cost attributed to improved construction methods, thus resulting in a significant increase in capital costs. If it is assumed that fixed facility costs are 25 percent higher, total route-miles of maglev systems where estimated revenues cover at least 100 percent of estimated capital and operating costs would fall from 850 (base scenario) to 700 miles, and route-miles covering operating cost and 50 percent or greater of capital cost would be reduced from 3,000 miles to 2,500 miles.

If the *operating cost* per passenger-mile were doubled, the total number of maglev system route-miles where revenues cover 100 percent of estimated capital and operating cost would be reduced to about 700 miles, or about the same as from increasing fixed costs by 25 percent.

By contrast, if land acquisition costs are held to an absolute minimum through the use of existing rights-of-way and improvements in construction methods permit fixed-facility capital costs to be reduced by 25 percent, total route-miles where estimated revenues cover 100 percent total estimated costs would rise from 850 to 1,300 miles. Route-mileage at 50 percent coverage would increase from 3,000 to 3,700 miles.

For air and highway travel, it was assumed that short-distance travel times would be about the same in the future as they are today. Actual levels of congestion and future travel times are difficult to predict because of uncertainty about whether capacity can keep up with growth, either through new construction, better management of existing capacity, or technological improvements. However, if 15 minutes were added at each end of an air trip to reflect

increased congestion in the air and/or increased congestion for ground access, and average highway speed were to be reduced from an assumed 50 mph to 45 mph for automobile trips, projects that cover 100 percent of capital costs would again increase to 1,300 miles.

As has been seen above, the amount of maglev service that would be considered commercially feasible varies depending on the assumptions used for future scenarios. The results are summarized in Table 1. In the unfavorable scenario (a 25 percent increase in fixed facility costs and doubled operating costs), the amount of service projected to cover all operating and maintenance costs decreases substantially, to less than 500 miles. Still another, more pessimistic, scenario can be constructed using the unfavorable assumptions *and* assuming that ridership is 25 percent below expectations. In that case even the best route segment would fall just short of covering costs.

On the favorable side, improved construction methods resulting in a 25 percent reduction in fixed-facility costs and increased air and highway congestion would result in a much larger self-sufficient network with dramatic increase in service coverage where estimated revenues cover either 50 percent or 100 percent of estimated capital costs. These results serve to underline the need for further technical and economic investigation to narrow the range of uncertainty.

**Table 1.
Estimated Maglev Route-Miles
Covering Operating Costs Plus
Different Percentages of Capital Costs**

<i>Recovery of Capital Cost*</i>	<i>Unfavorable Scenario</i>	<i>Base Scenario</i>	<i>Favorable Scenario</i>
100 percent	<500	850	2,600
50 percent	1,500	3,000	5,000

* Excludes right-of-way costs

Economic Issues Requiring Further Investigation

During the course of this study, it has become evident that there are numerous uncertainties involved in estimating costs, revenues, and other benefits. Before definitive conclusions can be drawn regarding maglev's economic feasibility, these uncertainties must be investigated. Areas for further research are described below.

- More precise information is needed on travel patterns in high-volume markets and on traveler behavior. Of particular importance is improved data on automobile use. Better data are also needed on how consumers are expected to respond to a maglev system, including how responses differ according to socio-economic status and business versus non-business travel and how response to maglev would differ from response to high-speed rail.
- Further analysis is needed on the maglev network concept, including the possibility of a more extensive network, attracting trips between city pairs as much as 800 miles apart. Study is also needed of the dynamics of building a network over time and of how a maglev network can be incrementally connected to the existing air and surface transportation systems.
- Further analysis is needed on the cost of building and operating a more advanced maglev system and of how costs vary with specific design and performance criteria. Because of the importance of fixed-facility costs, a more detailed site-specific analysis should be undertaken with particular attention to the availability and suitability of Interstate Highway and other rights-of-way for maglev use in light of performance criteria and the likely cost of acquiring and building on alternative rights-of-way.

Chapter Five

Measures to Promote U.S. Leadership in Maglev

Today, the leadership in maglev technological development belongs to West Germany and Japan. Building, in part, on technological advances funded by the FRA in the late 1960s and early 1970s and on concepts published by American scientists during the same period, the maglev development programs in both countries have advanced to the point of commercial application. West Germany is actively marketing its Transrapid system in the United States and ground may be broken later this year on a Transrapid maglev system near Orlando, Florida. Japan is in the final stages of its maglev system, committing over \$2 billion (U.S.) to construct a segment that will later become part of a commercial maglev link between Tokyo and Osaka early in the 21st century.

It will be a great challenge for the United States to move to a position of world leadership in maglev technology and its commercial applications. This is not to say the task is impossible, because, as Chapter Three of this report shows, there are opportunities to develop a better maglev system than those currently available. This Nation's long history of scientific and technological breakthroughs is evidence that U.S. industry is capable of that development, but it will not be an easy challenge to meet.

The FRA has held extensive discussions with companies that might be expected to participate in a maglev development program. In addition, FRA, together with the U.S. Army Corps of Engineers and the Department of Energy, held a Government/industry forum in May 1990, to discuss maglev development with a cross-section of the private sector interested in maglev development. In these discussions, the companies, representatives of the academic community, and potential developers of maglev systems expressed their opinions on what will be required if the United States is to assume a leadership role in maglev. A consistent, underlying theme of the suggestions that came from industry was that the Federal Government must make a major long-term commitment to maglev development. Suggestions as to how this commitment might manifest itself are the subject of this chapter. These suggestions can

generally be viewed as either issues involved in the research and development of a U.S.-based maglev technology or issues involved in the implementation of specific maglev systems.

Stimulating Maglev Research and Development

The American private sector has indicated its view that an extensive research and development program is necessary if the United States is to assume a leadership role in maglev technology. They indicated two efforts as important to a maglev development program: (1) removing barriers to carrying out a comprehensive public-private maglev research program; and (2) providing adequate funding for maglev research and development.

Removing Barriers to Maglev Research and Development

The American private sector believes that there are significant legal and financial impediments to a program to develop a domestic maglev technology. These impediments are part of the "traditional" American way of doing business. It will be up to Congress and the President to determine whether the potential for development of maglev justifies the legislative changes needed to eliminate them.

Antitrust

Significant questions have arisen over whether traditional antitrust considerations of domestic market dominance and assurance of adequate competition have been stressed to the detriment of other issues relating to the United States' competitiveness in world markets. Of particular concern are the foreign industrial consortia that are encouraged—even subsidized—by their national governments to develop and market advanced products such as maglev. The magnitude of the maglev challenge is such that it is unlikely that one company, acting alone, will be successful. However, under current law, industry consortia such as those engaged in the development of maglev overseas, would not be permitted in the United States.

The Department is exploring options under the National Cooperative Research Act for promotion of joint research and development ventures consistent with Administration policy.

Patents

Maglev development can benefit from public-private partnerships, with the public sector providing a long-term vision of a common goal and with the private sector supplying the creative energy. A primary concern in such arrangements is the ownership of intellectual property rights that might result from maglev research and the ability to profit from these rights. The Congress attempted to address this issue in the Stevenson-Wydler Technology Innovation Act of 1980; however, companies likely to become involved in a U.S.-maglev development program expressed serious reservations on this issue. They see the current arrangements concerning the ownership and exploitation of intellectual property as a disincentive to their involvement in a Federally sponsored maglev development program.

Financing Maglev Research and Development

Many people interested in the development of maglev systems in the United States look for the development of an American maglev technology or, at the very least, an American improvement of the existing foreign designs. While there are no firm cost estimates, such a development program will be expensive. The Maglev Technology Advisory Committee's report to the Senate Committee on Environment and Public Works contained an estimate that it would take \$750 million and six or seven years to develop a U.S.-based maglev technology.

Funding the development of maglev technology in the private sector will be a challenge. Private investors must be confident that the market for products of research and development efforts will be sufficiently large and profitable to amortize the research and development costs, as well as recover carrying charges and provide a reasonable profit on the research and development investment in a reasonable period of time. However, the private sector does not have sufficient confidence in the potential size and timing of the maglev market to commit funds to maglev research and development efforts and will look to the Federal Government for both leadership and funding.

Some States may contribute to the funding to ensure that technological spinoffs from the research would benefit those States in the form of a clean, technologically sophisticated industry and relatively high-paying skilled employment. As an example, Illinois has committed approximately \$300,000 to the Argonne National Laboratory's efforts to develop a maglev research facility near Chicago. But the sums needed to develop and test a maglev system are so vast that it is unlikely that such efforts will make significant progress without major involvement by the Federal Government.

The FRA's earlier maglev research activities were funded primarily through grants that covered most, if not all, costs. Such an arrangement may not be appropriate for a major maglev effort today. This is not just because Federal funds are limited. There are real advantages to private sector involvement, primarily those associated with crafting a system that can meet the unique requirements of the American marketplace. If the United States is to become fully committed to the development of maglev technologies and systems, one mechanism that should be considered is the formation of a Federally sponsored consortium of manufacturers and suppliers directed at common research and development goals.

Another possible way to undertake this development is demonstrated by DOT's Intelligent Vehicle Highway Systems (IVHS). In this effort, the Department is supporting cooperative ventures. One component of the effort is development of a state-of-the-art driving simulator. It is DOT's intention to encourage private industry, primarily the "big three" automakers, to contribute one-third of the approximately \$30 million cost of producing the simulator. The arrangement under consideration would be a cooperative agreement with a research facility (probably a university) and a contractor to manage the simulator.

Several pieces of legislation have been introduced that attempt to address some of the issues associated with Federal financial support for public-private partnerships undertaking maglev research and development. Under several of these measures, including the Administration's Water Resources Development Act of 1990, Federal agencies would be authorized to undertake collaborative research and development with non-Federal entities, including

universities and industry organizations. Government funding may be 50 percent of the cost of each project.

As part of the advanced maglev analysis proposed by FRA and the Corps of Engineers, the Federal agencies will determine the conditions and commitments that must exist to induce the private sector to undertake maglev research and development. From discussions held with corporations that would be expected to play a major role in maglev development, one thing is clear: industry believes that the Federal Government must make a major long-term commitment to maglev development before the corporations will commit substantial amounts of their own resources. Several corporations have questioned the strength of the Federal commitment to maglev and pointed to other instances, such as Federally funded maglev research prior to 1975, when the Federal Government did not pursue ongoing research and development to a conclusion, but instead abruptly shut down an ongoing effort.

Facilitating Implementation of Specific Maglev Projects—Institutional and Regulatory Issues

A key to U.S. industry's leadership in the commercial application of maglev technology is the presence of a domestic market for this technology. Specifically, U.S. industry leadership requires a market that will purchase this technology in sufficient quantity, and over a sufficiently short time, to justify the investment of resources in the development of a U.S. maglev technology.

Essential to the development of a significant maglev market is the ability to address institutional and regulatory issues that can delay or increase project costs, and the likely availability of project financing.

The FRA has had a long and close relationship with States and localities interested in promoting high-speed ground transportation, as well with as private entrepreneurs interested in developing systems such as maglev. These States, localities, and entrepreneurs have expressed their beliefs that certain institutional and regulatory issues must be clarified before the transportation and commercial potential of maglev can be realized. The most important of these are summarized below.

Use of Interstate Highway Rights-of-Way

It has been suggested that capital needs for a maglev system could be reduced by using a portion of the rights-of-way of Interstate and other highways. Aside from the technical issue of whether this is feasible and the economic issue of whether this is cost-effective, there are important legal issues.

The most pressing legal concern is related to the cost of using the rights-of-way. Interstate and other Federal-aid highways are owned by the States in which they are located; however, the FHWA must approve any non-highway use of this property. Under existing law, the FHWA requires the States to obtain fair market value for any commercial use of the rights-of-way, such as private maglev systems, even if the State wishes to encourage its use by making the right-of-way available at little or no cost.

Legislation has been introduced in both houses of Congress which, if enacted into law, would require DOT to issue regulations covering requests by states to permit maglev systems to use Interstate Highway rights-of-way. DOT has not taken a formal position on these bills at the time of this report (June 1990). It should be noted, however, that the bills did not address all the issues concerning maglev use of highway rights-of-way, such as the ability of States to offer use of the rights-of-way at little or no cost to commercial maglev systems as an inducement to the development of maglev.

Use of Railroad Rights-of-Way

Almost all railroad rights-of-way are privately owned. Use of such rights-of-way is, therefore, strictly a matter of negotiation between the maglev entity and the transportation entity owning the particular railroad right-of-way being considered.

Eminent Domain

Assembling transportation corridors often requires the use of the eminent domain powers of the State. (Federal eminent domain powers are almost never used for transportation purposes.) In some States, the State constitution or State law provides eminent domain powers to railroads (which might also be conferred upon maglev systems). In other States, this power must be exercised directly by the State. In such cases, it could be possible for States to assist in the assembly of the maglev corridor right-of-way, but this might require special State

legislation. This is an issue that FRA believes is best left to the specific States involved in encouraging high-speed ground transportation projects.

Economic Regulation

Section 306 of the Rail Passenger Service Act exempts the National Railroad Passenger Corporation (Amtrak) from most provisions of Subtitle IV of 49 U.S.C., formerly known as the Interstate Commerce Act. Except for this specific exemption, the Interstate Commerce Commission (ICC) continues to have authority to regulate the interstate transportation of passengers by rail.

How this latent authority would affect maglev development in the United States is unclear. DOT's recent National Transportation Policy Statement advocates eliminating all remaining ICC regulation of rail passenger service. This would include any ICC authority over maglev. The ICC could address this issue by granting an exemption from ICC regulation of passenger service. Alternatively, this elimination of authority could be accomplished legislatively.

Financing Implementation of Maglev Projects

The FRA expects that specific maglev projects will be funded largely in the private sector with, perhaps, some assistance or financial inducements from State and local governments. High-speed rail projects proposed for Florida, Texas, California, and Nevada are planning this type of funding. The FRA does not foresee a major role for the Federal Government in providing direct financial support to specific maglev projects. Such a role would negate one of the important benefits of private-sector participation, the ability to assess profit potential successfully and balance profit potential against risks and uncertainties.

Two points must be emphasized concerning financing strategies. First, no single financing mechanism, in isolation, will meet all the financial needs to implement maglev systems; these are large-scale projects requiring multiple financing tools. Second, hybrid financial mechanisms may be necessary. Large maglev development projects, particularly if public/private partnerships are involved, are likely to be "atypical." Creativity and careful planning are required.

Private Sector Financing

Chapter Four indicates that a number of maglev projects could potentially fund not only all capital and operating costs but also could generate a profit from fare revenues. Such projects could find financing through the traditional private-sector financing tools of equity investment and debt. Other projects would not be able to generate sufficient funds from farebox revenues to cover all costs and provide an adequate profit but these projects could still attract private sector financing by the addition of other incentives to private investment.

One way to improve the financial performance of a maglev project is to incorporate revenues from sources other than the operation of the transportation facility. These non-transportation revenues either can be a direct source of funds or can serve as security to raise financing through the issuance of debt instruments. Perhaps the greatest potential revenue source in this regard is real estate development near stations on a maglev system.

Another way to increase the effective yield and, therefore, the relative attractiveness of an investment, is the use of tax-exempt financing. Depending on their availability, the use of tax-exempt financing tools could be part of the financing package for many maglev projects. These tools may include issuing what used to be referred to as industrial development bonds (IDBs), that is, bonds issued by a governmental unit and used to finance operations employed in the trade or business of a private entity to produce public benefits. Because of changes in Federal tax laws, not all IDBs may be considered tax exempt.

The tax code was amended in 1988 to include as facilities eligible for tax-exempt bond financing "high-speed intercity rail facilities," which are defined to include "any facility (not including rolling stock) for the fixed guideway rail transportation of passengers and their baggage between metropolitan statistical areas . . . using vehicles that are reasonably expected to operate at speeds in excess of 150 miles per hour between scheduled stops, but only if such facility will be available to the general public."

There remain aspects of the tax code that would hinder the use of tax-exempt financing to support maglev implementation. First, although the high-speed intercity rail facilities financed with the proceeds of such bonds need

not be governmentally owned, a private owner must make an irrevocable election not to claim depreciation or other tax credits with respect to such property. Second, 25 percent of each issue must receive an allocation from the state's private activity bond volume which has a dollar ceiling based upon state population. Third, any proceeds of an issue not spent within three years of the date of issue must be used to redeem outstanding bonds.

Public Financing

The results of the preliminary analysis in Chapter Four show that there are potential transportation markets that could cover the operating costs and a portion of the capital costs of a maglev system. Public entities may choose to provide support for proposed private sector maglev systems that are unable to generate sufficient capital in the private sector to avoid more costly infrastructure investments elsewhere or for other public purposes.

Federal financial assistance, in FRA's view, will not play the dominant role in any public financial support for realizing specific maglev systems. States and local governments will be the primary focus of any public assistance for implementing specific maglev systems. These governmental entities may choose to provide direct financial assistance raised through taxes,

assessments, or other revenue sources available to state and local governments. Direct financial assistance to private entrepreneurs may be undesirable or impossible due to State or local statute, governmental policy, or public opinion. In these cases, the entities may consider an offer of incentives to maglev-system developers such as various forms of tax incentives or the enhanced real estate development rights that will be part of the franchise granted for a high-speed rail-line in Florida.

Future Action

The study conducted by FRA and summarized in this report must be considered preliminary. As a consequence, this report does not contain any specific recommendations by the Administration for legislative action. The President's fiscal year 1991 budget request would fund a detailed examination of the issues that FRA has identified in its discussions with companies, academia, and entrepreneurs who would be expected to participate in maglev development and implementation. In a report on that effort, scheduled for the spring of 1992, FRA expects to be able to offer the results of that detailed examination and formal recommendations for any legislative action needed to promote U.S. leadership in the commercial applications of maglev.

**PROPERTY OF FRA
RESEARCH & DEVELOPMENT
LIBRARY**

Assessment of the Potential for Magnetic Levitation
Transportation Systems in the United States, A
Report to Congress, Moving America, New
Directions, New Opportunities, US DOT, FRA,
1990-11-Advanced Systems