



P
1-5
1-6
1-8
1-24
1-29
1-20
7-4
8-4
9-5
9-11

11 - Advanced Systems

ELECTRIC RESEARCH
& MANAGEMENT, INC.

**FINAL REPORT ON
MAGNETIC AND ELECTRIC FIELD TESTING
OF THE WASHINGTON METROPOLITAN AREA
TRANSIT AUTHORITY METRORAIL SYSTEM**

VOLUME I - ANALYSIS

DRAFT

prepared for:

**U.S. DEPARTMENT OF TRANSPORTATION
FEDERAL RAILROAD ADMINISTRATION**

CONTRACT NO. DTFR53-91-C-00047

prepared by:

**ELECTRIC RESEARCH AND MANAGEMENT, INC.
P.O. BOX 165
STATE COLLEGE, PA 16804**

JANUARY 1993

**SYSTÈME INTERNATIONAL (SI) UNIT DEFINITIONS AND
CONVERSIONS USED IN THIS REPORT**

DISTANCE (ENGLISH-TO-SI CONVERSION):

1 inch (in)	= 2.54 centimeters (cm)	= 0.025 meters (m)
1 foot (ft)	= 30.5 centimeters (cm)	= 0.305 meters (m)
1 yard (yd)	= 91.4 centimeters (cm)	= 0.914 meters (m)
1 mile (mi)	= 1.61 kilometers (km)	= 1,610 meters (m)

ELECTRICAL QUANTITIES:

Electric Fields

1 Volt/meter (V/m)	= 0.01 Volts/centimeter (V/cm)
1 kiloVolt/meter (kV/m)	= 1000 Volts/meter (V/m)
1 kiloVolt/meter (kV/m)	= 10 Volts/centimeter (V/cm)

Magnetic Flux Densities (English-to-SI Conversion)

10,000 Gauss (G)	= 1 Tesla (T)
10 milliGauss (mG)	= 1 microTesla (μ T)
1 milliGauss (mG)	= .1 microTesla (μ T)
0.01 milliGauss (mG)	= 1 nanoTesla (nT)

Electromagnetic Frequency Bands

1 cycle per second	= 1 Hertz (Hz)
1,000 cycles per second	= 1 kiloHertz (kHz)
Ultra Low Frequency (ULF) Band	= 0 Hz to 3 Hz
Extreme Low Frequency (ELF) Band	= 3 Hz to 3 kHz
Very Low Frequency (VLF) Band	= 3 kHz to 30 kHz
Low Frequency (LF) Band	= 30 kHz to 300 kHz

TABLE OF CONTENTS

<u>VOLUME I - ANALYSIS</u>	<u>PAGE</u>
1.0 EXECUTIVE SUMMARY	1-1
1.1 Background	1-1
1.2 Measurement Approach	1-2
1.3 Summary of Metrorail Field Levels	1-4
1.3.1 Cars	1-4
1.3.2 Engineer's Compartment	1-4
1.3.3 Metrorail Waysides	1-5
1.3.4 Passenger Station Platforms	1-6
1.3.5 Traction Power Supply Stations	1-7
1.3.6 Control Facilities	1-7
1.4 Comparison of Metrorail Fields to Other Electro-technologies	1-7
1.4.1 Static Fields	1-8
1.4.2 Frequency Spectrum	1-8
1.4.3 Time Characteristics	1-8
1.4.4 Amplitude Characteristics	1-8
1.4.4.1 Cars	1-9
1.4.4.2 Engineer's Compartment	1-9
1.4.4.3 Along the Wayside	1-9
1.4.4.4 Passenger Stations	1-14
1.4.4.5 Power Supply System Measurements	1-14
1.4.4.6 Control Areas	1-14
1.5 Conclusions	1-14
2.0 OVERVIEW	2-1
2.1 Report Organization	2-1
2.2 Background	2-2
2.3 The WMATA Metrorail System	2-4
2.4 An Approach to Organizing Electromagnetic Data ...	2-6
2.5 Instrumentation	2-7
2.6 Repetitive Waveform Data	2-9
2.7 DAT Waveform Data	2-10
2.8 EMDEX-II Data	2-11
3.0 ONBOARD CAR MEASUREMENTS	3-1
3.1 Measurement Locations	3-1
3.2 Repetitive Waveform Datasets	3-3
3.3 Magnetic Field Characteristics	3-5

TABLE OF CONTENTS (CONT'D)

<u>VOLUME I - ANALYSIS</u>	<u>PAGE</u>
3.4 DAT Waveform Data	3-23
3.5 EMDEX-II Data	3-27
3.6 Summary of Magnetic Field Levels	3-27
3.7 Summary of Electric Field Sources and Levels	3-38
 4.0 ENGINEER'S COMPARTMENT MEASUREMENTS	 4-1
4.1 Measurement Locations	4-1
4.2 Repetitive Waveform Datasets	4-1
4.3 Magnetic Field Characteristics	4-2
4.4 DAT Waveform Data	4-2
4.5 EMDEX-II Data	4-2
4.6 Summary of Magnetic Field Levels	4-2
4.7 Summary of Electric Field Sources and Levels	4-8
 5.0 MEASUREMENTS ALONG THE WAYSIDE	 5-1
5.1 Measurement Locations	5-1
5.2 Repetitive Waveform Datasets	5-1
5.3 Magnetic Field Characteristics	5-4
5.3.1 At Underpass	5-4
5.3.2 At An Open Space	5-7
5.4 DAT Waveform Data	5-9
5.5 Summary of Magnetic Field Levels	5-9
5.6 Summary of Electric Field Levels	5-11
 6.0 PASSENGER STATION MEASUREMENTS	 6-1
6.1 Measurement Locations	6-1
6.2 Repetitive Waveform Datasets	6-4
6.3 Magnetic Field Characteristics	6-4
6.4 DAT Waveform Data	6-13
6.5 EMDEX-II Data	6-14
6.6 Summary of Magnetic Field Levels	6-18
6.7 Summary of Electric Field Levels	6-25
 7.0 POWER SUPPLY SYSTEM MEASUREMENTS	 7-1
7.1 Measurement Locations	7-1
7.2 Repetitive Waveform Datasets	7-4
7.3 Magnetic Field Characteristics	7-4
7.4 DAT Waveform Data	7-9
7.5 EMDEX-II Data	7-9
7.6 Summary of Magnetic Field Levels	7-12
7.7 Summary of Electric Field Levels	7-19

TABLE OF CONTENTS (CONT'D)

<u>VOLUME I - ANALYSIS</u>	<u>PAGE</u>
8.0 MEASUREMENTS IN CONTROL FACILITIES	8-1
8.1 Measurement Locations	8-1
8.2 Repetitive Waveform Datasets	8-1
8.3 Magnetic Field Characteristics	8-1
8.4 DAT Waveform Data	8-8
8.5 EMDEX-II Data	8-8
8.6 Summary of Magnetic Field Levels	8-8
8.7 Summary of Electric Field Levels	8-10
9.0 CONCLUSIONS	9-1
9.1 Summary of Metrorail Field Levels	9-2
9.1.1 Cars	9-2
9.1.2 Engineer's Compartment	9-3
9.1.3 Metrorail Waysides	9-3
9.1.4 Passenger Station Platforms	9-4
9.1.5 Traction Power Supply Stations	9-5
9.1.6 Control Facilities	9-5
9.2 Environmental Magnetic Field Levels	9-5
9.3 Comparison of Metrorail Fields to Other Electro-technologies	9-8
9.3.1 Static Fields	9-11
9.3.2 Frequency Spectrum	9-11
9.3.3 Time Characteristics	9-11
9.3.4 Amplitude Characteristics	9-11
9.3.4.1 Cars	9-12
9.3.4.2 Engineer's Compartment	9-12
9.3.4.3 Along the Wayside	9-12
9.3.4.4 Passenger Stations	9-17
9.3.4.5 Power Supply System Measurements	9-17
9.3.4.6 Control Areas	9-17
9.4 Comparison of Metrorail Fields to Existing Standards	9-17
9.4.1 World Health Organization	9-21
9.4.2 International Radiation Protection Association	9-23
9.4.3 American Conference of Governmental Industrial Hygienists	9-23
9.4.4 State Power Line Limits	9-24

TABLE OF CONTENTS (CONT'D)

<u>VOLUME I - ANALYSIS</u>	<u>PAGE</u>
10.0 REFERENCES	10-1

VOLUME II - APPENDICES

<u>APPENDIX</u>	<u>TITLE</u>
A	Description of Appended Data
B	Dataset MET001 - Center of Aisle, Center of Car #1173
C	Dataset MET002 - Center of Aisle, Rear of Car #1173
D	Dataset MET003 - In Front of Operator's Seat, Car #1173
E	Dataset MET004 - Center of Aisle, Center of Car #3012
F	Dataset MET006 - Center of Aisle, Center of Car #3012
G	Dataset MET007 - Center of Aisle, Center of Car #3012
H	Dataset MET008 - Center of Aisle, Rear of Car #3012
I	Dataset MET009 - In Front of Operator's Seat, Car #3012
J	Dataset MET010 - Axial Profile at Rear of Car #3012
K	Dataset MET011 - Transverse Profile at Rear of Car #3012
L	Dataset MET012 - Transverse Profile in Center of Car #3090
M	Dataset MET013 - Axial Profile in Center of Car #3090
N	Dataset MET014 - Near Left Center Door of Car #3090
O	Dataset MET015 - Grosvenor Station, North Bound Side of Platform

TABLE OF CONTENTS (CONT'D)

VOLUME II - APPENDICES

<u>APPENDIX</u>	<u>TITLE</u>
P	Dataset MET017 - Grosvenor Station, South Bound Side of Platform
Q	Dataset MET018 - Grosvenor Station, South Bound Side of Platform
R	Dataset MET019 - Grosvenor Station, Bottom of Escalator
S	Dataset MET021 - Grosvenor Station, On the Escalator
T	Dataset MET022 - Grosvenor Station, North Bound Side of Platform
U	Dataset MET024 - Grosvenor Station, North Bound Side of Platform
V	Dataset MET025 - Grosvenor Station, North Bound Side of Platform
W	Dataset MET026 - In Front of Operator's Seat in a 2000 Series Car
X	Dataset MET027 - Center of Aisle, Rear of a 2000 Series Car
Y	Dataset MET028 - Center of Aisle, Center of a 2000 Series Car
Z	Dataset MET029 - Axial Profile in Center of a 2000 Series Car
AA	Dataset MET030 - Transverse Profile in Center of a 2000 Series Car
AB	Dataset MET031 - Gallery Place Platform, South Bound Side
AC	Dataset MET032 - Gallery Place Platform, South Bound Side
AD	Dataset MET033 - Gallery Place Platform, North Bound Side

TABLE OF CONTENTS (CONT'D)

VOLUME II - APPENDICES

<u>APPENDIX</u>	<u>TITLE</u>
AE	Dataset MET034 - Gallery Place Platform, North Bound Side
AF	Dataset MET035 - On Mezzanine at Gallery Place Station
AG	Dataset MET037 - On Mezzanine at Gallery Place Station
AH	Dataset MET038 - At Traction Power Supply Station South of Shady Grove
AI	Dataset MET039 - At Traction Power Supply Station South of Shady Grove
AJ	Dataset MET040 - At Traction Power Supply Station South of Shady Grove
AK	Dataset MET041 - At Traction Power Supply Station South of Shady Grove
AL	Dataset MET042 - At Traction Power Supply Station South of Shady Grove
AM	Dataset MET043 - At Shady Grove Traction Power Supply Station
AN	Dataset MET044 - At Shady Grove Traction Power Supply Station
AO	Dataset MET045 - At Shady Grove Traction Power Supply Station
AP	Dataset MET046 - Shady Grove Dispatcher's Room, At Dispatcher's Chair
AQ	Dataset MET047 - Shady Grove Dispatcher's Room, From Monitors
AR	Dataset MET048 - Shady Grove Dispatcher's Room, From Mock-Up Panel
AS	Dataset MET049 - Center of Aisle, Center of a 3000 Series Car

TABLE OF CONTENTS (CONT'D)

VOLUME II - APPENDICES

<u>APPENDIX</u>	<u>TITLE</u>
AT	Dataset MET050 - Axial Profile in Center of a 3000 Series Car, Floor Level
AU	Dataset MET051 - Transverse Profile in Center of a 3000 Series Car, Floor Level
AV	Dataset MET052 - Transverse Profile in Center of a 3000 Series Car, 1 Meter Above Floor
AW	Dataset MET053 - Axial Profile in Center of a 3000 Series Car, 1 Meter Above Floor
AX	Dataset MET054 - Beneath Metrorail at Highway Underpass
AY	Dataset MET055 - Beneath Metrorail at Highway Underpass
AZ	Dataset MET056 - Along Wayside South of Shady Grove

LIST OF FIGURES

	<u>PAGE</u>
Figure 1-1	Metrorail System map showing the lines traveled and locations of measurements 1-3
Figure 1-2	The range of total time varying magnetic field levels in the Metrорail cars compared to typical levels of power frequency magnetic fields produced by common sources 1-10
Figure 1-3	The range of total time varying magnetic field levels in the center of the 3000 series Metrорail cars compared to typical levels of power frequency magnetic fields produced by common sources 1-11
Figure 1-4	The range of total time varying magnetic field levels in the engineer's compartment of the Metrорail cars compared to typical levels of power frequency magnetic fields produced by common sources 1-12
Figure 1-5	The range of total time varying magnetic field levels at a wayside and a highway underpass, at various distances from the nearest fence or track, compared to typical levels of power frequency magnetic fields produced by common sources 1-13
Figure 1-6	The range of total time varying magnetic field levels on the platforms, at various distances from the track, compared to typical levels of power frequency magnetic fields produced by common sources 1-15
Figure 1-7	The range of total time varying magnetic field levels outside traction power supply stations, at various distances from the fence or wall, compared to typical levels of power frequency magnetic fields produced by common sources 1-16

LIST OF FIGURES (CONT'D)

		<u>PAGE</u>
Figure 1-8	The range of total time varying magnetic field levels in front of a dispatcher's video display terminal compared to typical levels of power frequency magnetic fields produced by common sources	1-17
Figure 2-1	Magnetic field flux densities grouped by frequency partitions within the ELF band and ELF band	2-1
Figure 3-1	Repetitive waveform measurement locations within the cars and engineer's compartment ..	3-2
Figure 3-2	Magnetic field 10 cm above the floor in the center of a 1000 series car as a function of frequency and time. The static field component is suppressed in the lower frame to show the time varying components	3-6
Figure 3-3	Magnetic field 160 cm above the floor in the center of a 1000 series car as a function of frequency and time. The static field component is suppressed in the lower frame to show the time varying components	3-8
Figure 3-4	Static (top frame) and low frequency time varying (bottom frame) magnetic field in the center of a 1000 series car as a function of height above the floor and time	3-9
Figure 3-5	Magnetic field 10 cm above the floor in the rear of a 1000 series car as a function of frequency and time. The static field component is suppressed in the lower frame to show the time varying components	3-11
Figure 3-6	Magnetic field 160 cm above the floor in the rear of a 1000 series car as a function of frequency and time. The static field component is suppressed in the lower frame to show the time varying components	3-12

LIST OF FIGURES (CONT'D)

	<u>PAGE</u>
Figure 3-7	Static (top frame) and low frequency time varying (bottom frame) magnetic field in the rear of a 1000 series car as a function of height above the floor and time 3-13
Figure 3-8	Graphical comparison of static magnetic field levels 100 cm above the floor at the center of a 1000 series car based on statistical descriptors 3-14
Figure 3-9	Time varying magnetic field 10 cm and 160 cm above the floor at the center of a 2000 series car as a function of frequency and time 3-16
Figure 3-10	Magnetic field 10 cm above the floor in the center of a 3000 series car as a function of frequency and time. The static field component is suppressed in the lower frame to show the time varying components. Data at the 6 second data point are invalid 3-18
Figure 3-11	Magnetic field 160 cm above the floor in the center of a 3000 series car as a function of frequency and time. The static field component is suppressed in the lower frame to show the time varying components 3-19
Figure 3-12	Static (top frame) time varying (bottom frame) magnetic field in the center of a 3000 series car as a function of height above the floor. Data at 10 and 60 cm above the floor are invalid at the 6 second time point 3-20
Figure 3-13	Time varying magnetic field 10 cm above the floor at the center of a 3000 series car measured with coil-type sensors 3-22
Figure 3-14	Time domain plot of the changing static field level in a 1000 series car showing time-rates-of-change of static field up to 4 gauss per second 3-25

LIST OF FIGURES (CONT'D)

	<u>PAGE</u>
Figure 3-15	Time domain plot of the changing static field level near the center of a 3000 series car showing average rates of change, chopper ripple and an apparent transient field episode 3-26
Figure 5-1	Repetitive waveform measurement location at highway underpass at Rockville 5-2
Figure 5-2	Repetitive waveform measurement location at wayside, south of Shady Grove 5-3
Figure 5-3	Magnetic field level, with and without the static component, at 110 cm height above ground at the underpass as a function of frequency and time 5-5
Figure 5-4	Magnetic field level, with and without the static component, at 10 cm distance from the fence at the wayside, south of Shady Grove, as a function of frequency and time 5-8
Figure 5-5	Electric time varying field level 1.0 meter above ground, at 20 feet distance from the fence at the wayside, south of Shady Grove, as a function of frequency and time 5-13
Figure 6-1	Repetitive waveform measurement locations on the passenger platform at Grosvenor 6-2
Figure 6-2	Repetitive waveform measurement locations at the Gallery passenger transfer station platform and mezzanine 6-3
Figure 6-3	Magnetic field 10 cm above the floor at the edge of the Grosvenor station platform as a train enters, stops, and departs. The static field is suppressed in the lower frame to show the time varying components 6-5

LIST OF FIGURES (CONT'D)

	<u>PAGE</u>
Figure 6-4	Magnetic field 160 cm above the floor at the edge of the Grosvenor station platform as a train enters, stops and departs. The static field is suppressed in the lower frame to show the time varying components 6-7
Figure 6-5	Continuous magnetic field recording at the edge of the Grosvenor station platform at the arriving end as a train enters, stops, and departs 6-8
Figure 6-6	Continuous magnetic field recording at the edge of the Grosvenor station platform at the departing end as a train enters, stops, and departs 6-10
Figure 6-7	Continuous magnetic field recording at the edge of the Grosvenor station platform midway along the platform as a train enters, stops, and departs 6-12
Figure 6-8	Magnetic field level recorded on the passenger platform at Grosvenor using the EMDEX-II recorders, as a function of time 6-17
Figure 7-1	Repetitive waveform measurement locations at the Shady Grove power supply station 7-1
Figure 7-2	Repetitive waveform measurement locations at the traction power supply station south of Shady Grove 7-3
Figure 7-3	Magnetic field level, with and without the static component, at 110 cm distance from the wall at the Shady Grove traction power supply station, as a function of frequency and time 7-5

LIST OF FIGURES (CONT'D)

		<u>PAGE</u>
Figure 7-4	Magnetic field level versus distance from station wall at 1 meter height, for the power frequency (50-60 Hz) and the power frequency harmonics (65-300 Hz) components, at the traction power supply station south of Shady Grove, as a function of time	7-6
Figure 7-5	Magnetic field level, with and without the static component, at 110 cm distance from fence and 1 meter height, at the Shady Grove traction power supply station, as a function of frequency and time	7-8
Figure 7-6	Magnetic field levels recorded outside the traction power supply station 2.5 miles south of Shady Grove using the EMDEX-II recorders, as a function of time	7-10
Figure 7-7	Magnetic field levels recorded outside the Shady Grove traction power supply station using the EMDEX-II recorders, as a function of time	7-11
Figure 7-8	Electric time varying field level 1.0 meter above the ground, 1.70 meters from the west wall at the traction power supply station south of Shady Grove, as a function of frequency and time	7-20
Figure 8-1	Repetitive waveform measurement locations inside the dispatcher's room at Shady Grove	8-2
Figure 8-2	Magnetic field level, with and without the static component, at 10 cm height above the floor by the dispatcher's seat inside the dispatcher's room at Shady Grove, as a function of frequency and time	8-3

LIST OF FIGURES (CONT'D)

	<u>PAGE</u>
Figure 8-3	Magnetic field level versus height above the floor for the static and time varying (5-2560 Hz) components, at the dispatcher's seat inside the dispatcher's room at Shady Grove, as a function of time 8-5
Figure 8-4	Magnetic field level, with and without the static component, at 10 cm distance from the dispatcher's video display monitor and 1.25 meters height, inside the dispatcher's room at Shady Grove, as a function of frequency and time 8-6
Figure 8-5	Magnetic field level versus distance from the dispatcher's video display monitor and 1.25 meters height for the static and time varying (5-2560 Hz) components, inside the dispatcher's room at Shady Grove, as a function of time 8-7
Figure 8-6	Magnetic field levels recorded inside the Shady Grove dispatcher's room using the EMDEX-II recorders, as a function of time 8-6
Figure 8-7	Electric time varying field level 1.80 meters above the floor, at the dispatcher's seat at Shady Grove, as a function of frequency and time 8-12
Figure 9-1	Illustration of how the magnetic field intensity at ground level changes with horizontal distance from three common sources of power-frequency magnetic fields. The bands represent variation across individual sources in each group. Adapted from Nair, et al ⁵ 9-7
Figure 9-2	Magnetic field 30 cm from a shop vac 9-9

LIST OF FIGURES (CONT'D)

PAGE

Figure 9-3 Illustration of how electric field intensity near ground level will change with horizontal distance from three common sources of power-frequency electric fields. The bands represent variation across individual sources in each group. Adapted from Nair, et al⁵ ...9-10

Figure 9-4 The range of total time varying magnetic field levels in the Metrorail cars compared to typical levels of power frequency magnetic fields produced by common sources 9-13

Figure 9-5 The range of total time varying magnetic field levels in the center of the 3000 series Metrorail cars compared to typical levels of power frequency magnetic fields produced by common sources 9-14

Figure 9-6 The range of total time varying magnetic field levels in the engineer's compartment of the Metrorail cars compared to typical levels of power frequency magnetic fields produced by common sources 9-15

Figure 9-7 The range of total time varying magnetic field levels at a wayside and a highway underpass, at various distances from the nearest fence or track, compared to typical levels of power frequency magnetic fields produced by common sources 9-16

Figure 9-8 The range of total time varying magnetic field levels on the platforms, at various distances from the track, compared to typical levels of power frequency magnetic fields produced by common sources 9-18

LIST OF FIGURES (CONT'D)

	<u>PAGE</u>
Figure 9-9	The range of total time varying magnetic field levels outside traction power supply stations, at various distances from the fence or wall, compared to typical levels of power frequency magnetic fields produced by common sources 9-19
Figure 9-10	The range of total time varying magnetic field levels in front of a dispatcher's video display terminal compared to typical levels of power frequency magnetic fields produced by common sources 9-20
Figure 9-11	Comparison of maximum and average magnetic field levels measured 60 cm above the floor in the center of a Metrorail 3000 series car to existing standards 9-22

LIST OF TABLES

		<u>PAGE</u>
Table 3-1	Repetitive magnetic field waveform datasets measured onboard Metro cars classified by type and staff location	3-4
Table 3-2	Summary of static magnetic field levels recorded in a passenger seat of a Metrorail car recorded with the digital audio tape recorder (DAT)	3-24
Table 3-3	Statistical summary of magnetic field levels recorded in 3000 series cars using EMDEX-II recorders	3-28
Table 3-4	Summary statistics for magnetic field levels measured in the center of a 1000 series car	3-30
Table 3-5	Summary statistics for magnetic field levels measured in the rear of a 1000 series car	3-31
Table 3-6	Summary statistics for magnetic field levels measured in the center of a 2000 series car	3-32
Table 3-7	Summary statistics for magnetic field levels measured in the rear of a 2000 series car	3-33
Table 3-8	Summary statistics for magnetic field levels in the rear of a 3000 series car	3-34
Table 3-9	Summary statistics for magnetic field levels in the center and rear of all cars except center of the 3000 series car ..	3-35
Table 3-10	Summary statistics for static magnetic field levels measured in the center of a 3000 series car (corrected for sensor saturation as discussed in text)	3-36
Table 3-11	Summary statistics for time varying magnetic field levels measured in the center of a 3000 series car	3-37

LIST OF TABLES (CONT'D)

		<u>PAGE</u>
Table 4-1	Summary of static magnetic field levels recorded in the engineer's seat of a Metrorail car recorded with the digital audio tape recorder (DAT)	4-3
Table 4-2	Summary statistics for magnetic field levels measured in the engineer's compartment of a 1000 series car	4-4
Table 4-3	Summary statistics for magnetic field levels measured in the engineer's compartment of a 2000 series car	4-5
Table 4-4	Summary statistics for magnetic field levels measured in the engineer's compartment of a 3000 series car	4-6
Table 4-5	Summary statistics for magnetic field levels measured in the engineer's compartment of all types of cars	4-7
Table 5-1	Repetitive magnetic field waveform datasets measured along the wayside	5-4
Table 5-2	Statistical summary of the magnetic field level at various heights above the road surface beneath the Metrorail at the highway underpass at Rockville (Datasets MET054 and MET055)	5-10
Table 5-3	Statistical summary of the magnetic field level at various distances from the train track fence, along the wayside south of Shady Grove (Dataset MET056)	5-12
Table 6-1	Summary of static magnetic field recorded at the edge of station platforms with the digital audio tape recorder (DAT) as trains pass	6-15
Table 6-2	Summary of static magnetic field levels recorded on a station mezzanine with the digital audio tape recorder (DAT) as trains pass below	6-16

LIST OF TABLES (CONT'D)

	<u>PAGE</u>
Table 6-3	Summary of magnetic field levels recorded on the Grosvenor passenger platform using EMDEX-II data recorders 6-16
Table 6-4	Statistical summary of the magnetic field level of combined vertical datasets at the safety line at the Grosvenor passenger station platform (datasets MET015, 017, 022 and MET024) 6-19
Table 6-5	Statistical summary of the magnetic field level at various heights above the floor at the bottom of escalator at the Grosvenor passenger station platform (Dataset MET019) 6-21
Table 6-6	Statistical summary of the magnetic field level at various heights above the moving steps while riding up and down on the escalator at the Grosvenor passenger station platform (Dataset MET021) 6-22
Table 6-7	Statistical summary of the magnetic field level of combined vertical datasets at the safety line of the lower platform at the Gallery passenger transfer station (datasets MET031 and MET033) 6-23
Table 6-8	Statistical summary of the magnetic field level of combined vertical datasets at the mezzanine of the Gallery passenger transfer station (datasets MET035 and MET037) 6-24
Table 7-1	Statistical summary of magnetic fields in mG recorded at traction power supply stations using EMDEX-II data recorders 7-12
Table 7-2	Statistical summary of the magnetic field level at various distances from the north wall, outside the traction power supply station 2.5 miles south of Shady Grove (Dataset MET038) 7-13

LIST OF TABLES (CONT'D)

	<u>PAGE</u>
Table 7-3	Statistical summary of the magnetic field level at various distances from the walls, of combined datasets outside the traction power supply station of Shady Grove (Datasets MET038 through MET042) 7-14
Table 7-4	Statistical summary of the magnetic field level at various distances from the south fence, outside the Shady Grove traction power supply station (Dataset MET043) 7-15
Table 7-5	Statistical summary of the magnetic field level at various distances from the south wall, outside the Shady Grove traction power supply station (Dataset MET044) 7-16
Table 7-6	Statistical summary of the magnetic field level at various distances from the west wall, outside the Shady Grove traction power supply station (Dataset MET045) 7-17
Table 8-1	Statistical summary of magnetic fields in mG recorded inside the dispatcher's room using EMDEX-II data recorders 8-8
Table 8-2	Statistical summary of the magnetic field level at various heights above the floor inside the dispatcher's room at Shady Grove (Dataset MET046) 8-11

1.0 EXECUTIVE SUMMARY

This report documents the low frequency electric and magnetic fields associated with the operation of the Washington, DC Metropolitan Area Transit Authority (WMATA) Metrorail (MET) Urban Transit System. With excellent cooperation and assistance of WMATA personnel, comprehensive measurements were made on, at and along the Metrorail lines and facilities.

1.1 Background

Extensive measurements have previously made and reported for three other electrified transportation systems^{1,2,3,4}. These include the Transrapid TR07 Maglev System at the test track in Emsland, Germany, AMTRAK and New Jersey Transit trains operating on the Northeast Corridor (NEC) and the North Jersey Coast Line respectively, and on the Train à Grande Vitesse (TGV) System in France. Measurements have been made but not yet reported on the numerous electrified systems which make up the Massachusetts Bay Transit Authority's (MBTA) mass transit system in the Boston area.

All of these measurements have been made using the *MultiWave*™ System instrumentation package developed under sponsorship of the Electric Power Research Institute (EPRI). This system quantifies both the spatial and temporal characteristics of the magnetic field. By recording the actual waveform of the magnetic field with sensors having frequency responses from 0 to 3 kHz, *MultiWave*™ makes it possible to examine the frequency characteristic as well throughout the ULF and ELF bands. (The reader who is unfamiliar with terms like "Hz" and "ELF" is encouraged to review the conversion table in the front of this report.) The *MultiWave*™ also recorded the electric field at head height. The *MultiWave*™ data was complemented by continuous field recordings at one sensor location made on a digital audio tape (DAT) recorder to capture transient events and with data from two EMDEX personal exposure meters which recorded the root mean square (rms) value of the magnetic field encountered by the wearers throughout the day.

The motivation for these extensive measurements was the creation of a database of the electric and magnetic field characteristics of conventional existing electrified rail transportation systems against which the field characteristics of new systems such as the Maglev can be evaluated. While Maglev magnetic field magnitudes were within the range of fields produced by other well documented field sources such as electric power lines and substations, the frequency and temporal characteristics differed from those relatively constant sources of single frequency fields. Magnitude comparisons alone for such temporally different sources are not appropriate for the multi-frequency and complex time characteristics associated with the Maglev.

To have the necessary data to fairly assess the electric and magnetic fields from any new electrified transportation system to be installed in the United States, the FRA research program sponsored a measurement program to fully characterize the ULF and ELF fields of four existing electrified rail systems. These include the AMTRAK Northeast Corridor, the French TGV, the Washington, DC Metrorail (MET), and data yet to be reported on the Boston Metro. With such a dataset, more appropriate comparisons can be made since the service functions are comparable.

1.2 Measurement Approach

The magnetic field and electric field measurements made on or near the WMATA Metrorail facilities were grouped into six areas:

- * within onboard passenger compartments;
- * within the engineer's compartment;
- * in the passenger stations;
- * along the track rights-of-way (wayside);
- * near the traction power supply stations; and
- * in a dispatcher's control room.

The results from measurements in each of these areas are presented in detail in a separate section of this report.

Measurements onboard the train were made in each of the three different types of cars operating on the WMATA system. The fields in each type of car were characterized in the center and rear of the passenger compartment and in the engineer's compartment.

At the stations, electric and magnetic field measurements were made at the center and ends of the platforms at points nearest the track where a person could reasonably stand, on mezzanines crossing over the tracks, and on escalators.

Wayside measurements were made to quantify the field environment in areas along the line route accessible to the general public. Measurements were taken at both a highway underpass and an open space along the wayside.

Traction power supply station measurements were made outside two different stations at various distances from the wall or fence enclosing the facility. Measurements were made at several locations around the periphery of each station.

Finally, field measurements were in the vicinity of a dispatcher's work-area to characterize fields within control facilities.

Figure 1-1 is a map of all the Metrorail lines. The onboard magnetic and electric field measurements were made on the Red Line between Shady Grove and Van Ness or on the Green Line between Gallery Place and U Street. The passenger station measurements

T.P.S.S. Gaithersburg

Figure 1-1

Metrorail System map showing the lines traveled and locations of measurements.

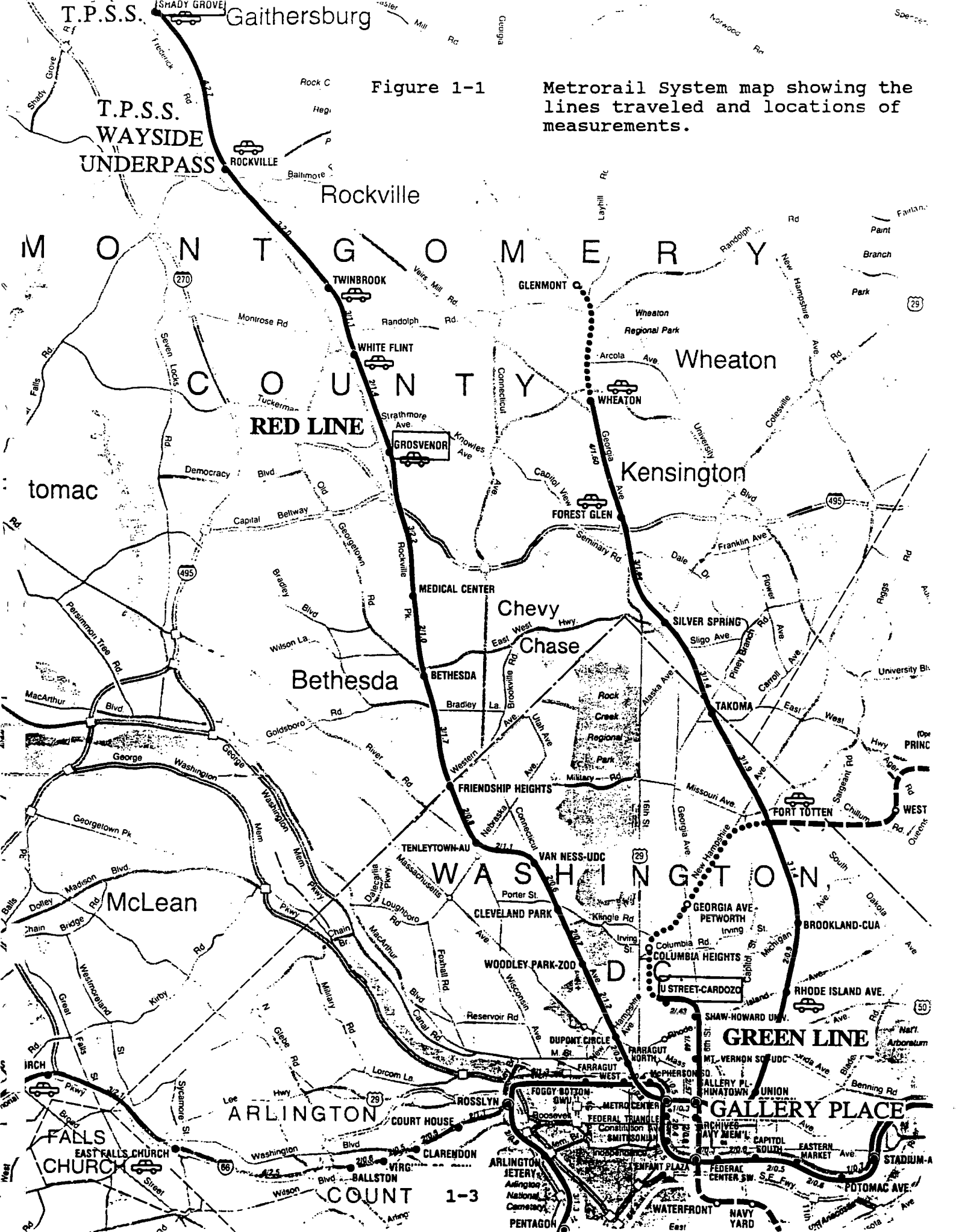

were taken at the Grosvenor outdoor platform and the Gallery Place underground transfer station. The wayside, dispatcher's room, and traction power supply station measurements were taken at sites along the northern end of the Red Line between Shady Grove and Rockville, as indicated on the map.

1.3 Summary of Metrorail Field Levels

The following is a concise description of the magnetic field characteristics at each of the areas examined. It should be noted that all measured electric fields were less than ten volts per meter (10 V/m) and did not appear to originate from the Metrorail transportation system or equipment.

1.3.1 Cars

The magnetic fields in the passenger areas of the Metrorail cars arise mainly from the traction power control equipment beneath the floor of the cars and also possibly the current in the loop created by the third rail and track return circuit. These fields are predominantly static with low frequency time varying components resulting from fluctuations in the static field level. However, large time varying magnetic fields are found near the center of the 3000 series cars which use 273 Hz semiconductor choppers to control the amount of electric power supplied to the traction motors. This central area of the 3000 series cars has a unique magnetic field environment in that both the static and time varying fields are much larger, especially near the floor, than the rest of the cars. The source is probably the large filter (smoothing) reactor coil under the center of the 3000 series car.

The static magnetic field at seat level (60 cm above the floor) in these dc powered Metrorail cars, excluding the central area of the 3000 series cars, averaged 1026 mG. The maximum static field encountered at seat height for the same samples was 4539 mG. The corresponding average and maximum dc fields 60 cm above the floor in the center of the 3000 cars are 2685 mG and 23,732 mG, respectively.

Correspondingly, the total time varying magnetic field levels averaged 12 mG over all samples and all sensor locations, except the center of the 3000 cars. The maximum time varying field encountered during the same periods was 65 mG. However, on the center of the 3000 series cars, the corresponding average and maximum time varying magnetic fields are 317 mG and 2987 mG, respectively.

1.3.2 Engineer's Compartment

The principal sources of magnetic field in the engineer's compartment are the same as in the passenger areas, that is,

the traction power equipment beneath the floor and possibly the current in the loop created by the third rail and the track return circuit. There appeared to be no additional sources unique to the engineer's compartment. As described in Section 1.3.1, these fields are predominantly static with low frequency time varying components resulting from fluctuations in the static field level. The measurements made onboard the three different types of cars are comparable to one another. Thus, an overall set of statistics is possible. The following summary values were obtained close to the engineer's seat.

The static magnetic field, as measured by the *MultiWave™* System, averaged 761 mG at seat level (60 cm height). The maximum static field encountered for the same 60 cm height was 3148 mG.

Correspondingly, the total time varying magnetic field levels averaged 11 mG at the 60 cm height level and the maximum field encountered was 24 mG.

1.3.3 Metrorail Waysides

The static magnetic field at the wayside of the Metrorail line arises from a combination of the earth's magnetic field and the static magnetic field due to the dc traction current in the rails. At locations outside the right-of-way exclusion fence, the static field from traction current in the third rail and tracks does not add appreciably to the natural static field environment. The time varying field at the wayside has components from three sources: changes in the dc traction current produce low frequency components whose magnitude depends on the rate of change of the dc current; second from the rectifier ripple currents in the rails and third from the 60 Hz current in any nearby commercial power lines. Since the magnetic field at the railroad wayside due to the current in the rails attenuates (becomes weaker) rapidly with distance from the tracks, at distances comparable to the exclusion fence location, the time varying field from common sources such as distribution lines equal of exceed the components from the Metrorail System.

The average value of the dc field measured at the wayside was 559 mG, which compares with the published value of 543 mG for Washington, DC. The largest dc value measured at the wayside was 733 mG. The average and maximum ac magnetic fields measured at the right-of-way exclusion fence were 7.01 mG and 7.45 mG, respectively, but those values are dominated by fields from nearby power lines. The average and maximum fields actually arising from the Metrorail System are estimated to be 0.8 mG and 1.3 mG, respectively.

Measurements beneath a Metrorail overpass found the average and maximum static field levels to be 485 mG and 566 mG with trains passing overhead. The measured average and maximum time varying field levels were 1.0 mG and 1.8 mG but those values included fields apparently arising from nearby power lines. The estimated average field from the Metrorail System was 0.4 mG with a maximum value of 1.6 mG.

The electric fields measured at the open space along the wayside were under 5 V/m.

1.3.4 Passenger Station Platforms

The magnetic field environment on a passenger station platform is similar to the wayside, except that the rider is closer to the rails. Static fields from traction power current in the third rail and track return circuit add to the naturally occurring geomagnetic field. The time varying magnetic field at the platforms arises from changes in the static (dc) component due to changing dc traction power in the rails, the rectifier harmonics in the rails and fields from the passing cars themselves. Moreover, there are 60 Hz fields from nearby electric equipment, such as station wiring, lights, and escalator motors.

The average values of the static field measured at body torso height (110 cm above the floor) near the edge of the outdoor and underground station platforms were 433 mG and 400 mG, respectively. The maximum value measured on the outdoor platform where 3000 series cars were operating was 1218 mG at torso height but near floor level, a maximum static field level of 3270 mG was recorded for a brief instant as a 3000 series car passed eighteen inches from the sensor. The maximum static field levels were substantially lower on the platform of the underground station. That difference is perhaps because 2000 series cars were passing the station rather than the 3000 series cars which produced the large maximum fields at the outdoor station.

The average and maximum time varying magnetic fields measured 110 cm above the edge of the outdoor platform were 2.3 mG and 22.7 mG, respectively. The corresponding values for the indoor platform were 1.2 mG and 10.0 mG. The difference in maximum field levels was in this case clearly due to the difference in types of cars operating at the two stations.

The electric fields measured on any of the platforms were under 5.2 V/m.

1.3.5 Traction Power Supply Stations

Only modest strength magnetic fields were observed outside the traction power supply stations. The largest measured static value was 1676 mG at a distance of 10 cm from the station wall. That static field was very localized and it decreased by 35% at a point 50 cm farther from the wall.

The average time varying magnetic field measured 10 cm from the fence or wall at eight locations around two stations was 4.7 mG however there was considerable variation in field levels from one location to another. The average and maximum field 10 cm from the wall at the six locations with the lowest fields (apparently near the ac portion of the station) were 2.7 mG and 8.3 mG, respectively. The two locations where the time varying fields were higher were presumably near the dc output portion of the station from the field frequency spectra. The average and maximum time varying magnetic fields at those locations were 6.4 mG and 21.1 mG, respectively.

The highest electric field measured at any of the stations was under 7 V/m and that field apparently came from a nearby distribution line rather than the traction power supply station.

1.3.6 Control Facilities

The major sources of magnetic fields in the dispatcher's area are the current in the building wiring which supplies power to the equipment and lights, and the equipment itself, such as video display terminals (VDT). The measured average and maximum ac magnetic fields in the dispatcher's room were 1.2 mG and 1.5 mG, respectively. Higher values were found close to equipment. The static field in the dispatcher's room was constant over time but varied from 1210 mG near the floor to 660 mG at 160 cm above the floor.

The electric fields measured at inside the dispatcher's room were under 1 V/m.

1.4 Comparison of Metrorail Fields to Other Electro-technologies

Much of the concern about ELF magnetic field levels is driven by uncertainty as to whether such fields exert an adverse effect on human health. Existing scientific knowledge provides no sound insight as to what aspects of ELF magnetic exposure, if any, are of biological concern. Consequently, public acceptance of magnetic field exposures is presently based more on equity and comparability to other exposures than it is to quantifiable characteristics of the field itself. Therefore, this section compares and contrasts the magnetic fields produced by the Metrorail operation to other sources of magnetic fields.

1.4.1 Static Fields

Static magnetic fields beyond normal range normally due to passive perturbation of the earth's geomagnetic field exist inside the cars, the engineer's compartment, at the wayside, on the platforms and outside the traction power supply stations because of the nature of the Metrorail electrification. The largest measured static fields were encountered at the center of the 3000 cars, near the floor. The maximum magnetic field reading 10 cm above the floor was 131.5 gauss at that point and the average was 14.3 gauss. That is an extreme example but total static fields in excess of 1 gauss occasionally existed at many measurement locations.

1.4.2 Frequency Spectrum

The frequency characteristics of the magnetic fields onboard or near the Metrorail cars is substantially different than those near many electrical appliances. The dc electrification gives rise to low frequency components which are the result of temporal changes in the dc traction current drawn by operating cars. Also, there are even harmonics of 60 Hz present that arise from the rectification ripple currents in the traction current. Moreover, the 3000 series cars contain semiconductor choppers and a filtering reactor coil, located beneath the middle of the car, which produce significant fields in the higher end of the ELF band.

1.4.3 Time Characteristics

The magnetic fields onboard the Metrorail cars or near the rails have pronounced temporal variability similar to the variability of magnetic fields near appliances with varying load or intermittent use. These fields have much greater variability than the fields found near most commercial electric power lines.

1.4.4 Amplitude Characteristics

This subsection compares the measured field levels onboard the Metrorail cars or near the Metrorail line and its facilities to the reported environmental field levels from various power frequency sources. This comparison is based on total ELF magnetic field and does not take into consideration the significant differences in frequency spectra. For considerations where frequency is an important factor, this comparison is invalid because Metrorail System fields which contain little or no 60 Hz component are compared to fields which are essentially entirely 60 Hz.

1.4.4.1 Cars

Figure 1-2 (Figure 9-4 in the Conclusions) shows the general range of total time varying magnetic fields measured in the cars on the Metrorail train as a function of distance from the source which for purposes of this graph is presumed to be the car floor. The range is plotted over the graph of a typical distribution line and appliance field levels. The intensity of the ELF magnetic field inside the cars diminishes away from the floor, but exhibits an increase towards the ceiling. The range of magnetic field intensities spans more than three orders of magnitude, including the range of magnetic fields found under all distribution lines and some transmission lines.

Figure 1-3 (Figure 9-5 in the Conclusions) shows the range of total time varying magnetic fields measured in the center of the 3000 series car on the Metrorail train as a function of distance from the source (car floor). The central area of the 3000 series cars exhibits much larger static and time varying fields, especially near the floor.

1.4.4.2 Engineer's Compartment

Figure 1-4 (Figure 9-6 in the Conclusions) shows the range of total time varying magnetic fields recorded in the Metrorail engineer's compartment as a function of distance from the catenary. The data are plotted over the same typical power frequency magnetic field levels. The magnetic field levels in the engineer's compartment are similar to those found in other parts of the cars and are within the range of field levels found beneath electric distribution lines or near appliances.

1.4.4.3 Along the Wayside

Figure 1-5 (Figure 9-7 in the Conclusions) shows the plot of the ranges corresponding to the two measurement locations, namely the underpass and the open space along the wayside. The distance to the source for the underpass is measured to the rails above. The distance for the open space is measured to the nearest set of tracks. These measured field levels included fields from both the Metrorail System and background fields from other sources. Consequently, the measured values overstate the magnitude of the field actually produced by the Metrorail System. The figure shows that these conservative measures of magnetic field levels at both locations are within the general range of magnetic fields near distribution lines.

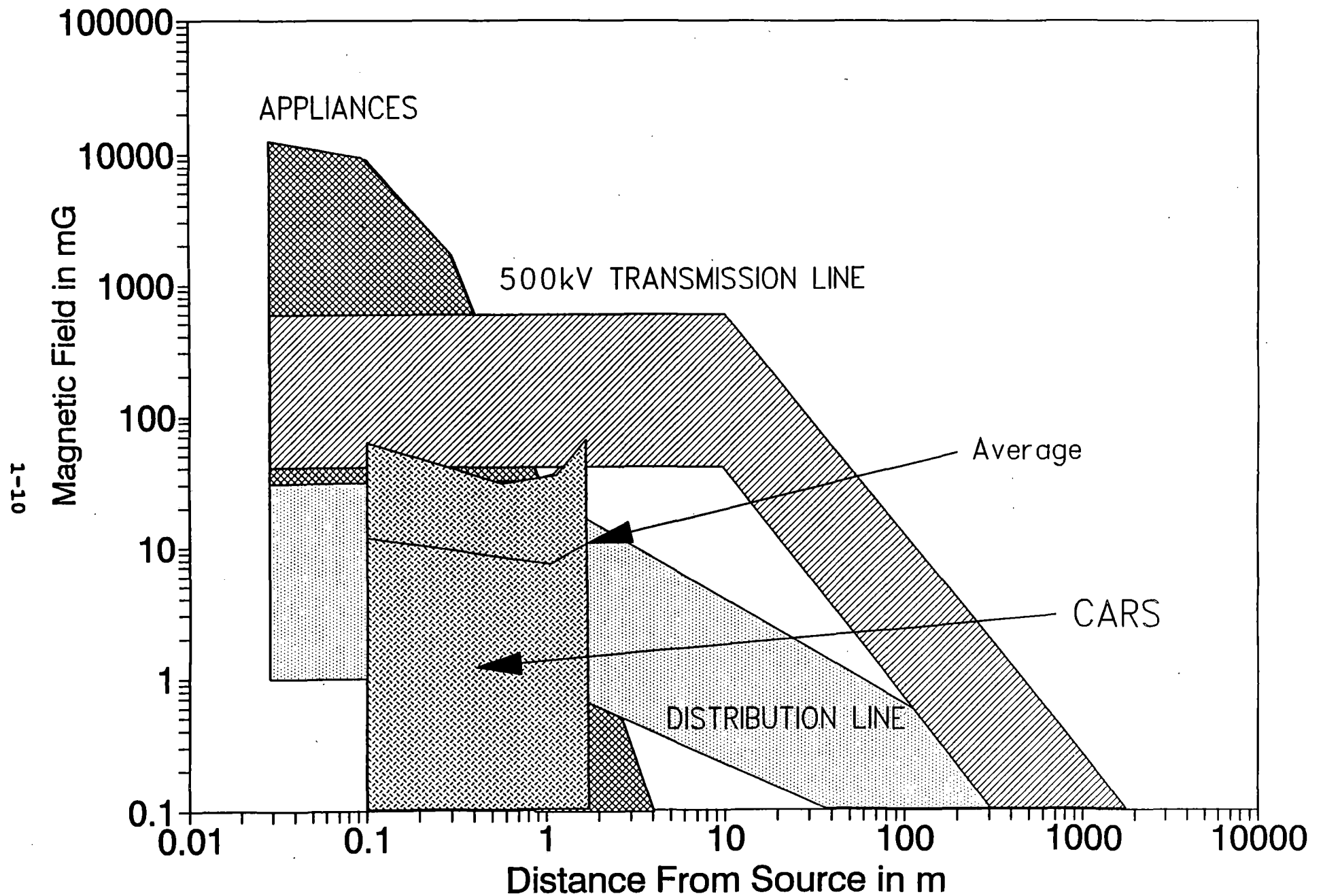

Figure 1-2 The range of total time varying magnetic field levels in the Metrorail cars compared to typical levels of power frequency magnetic fields produced by common sources.

11-1

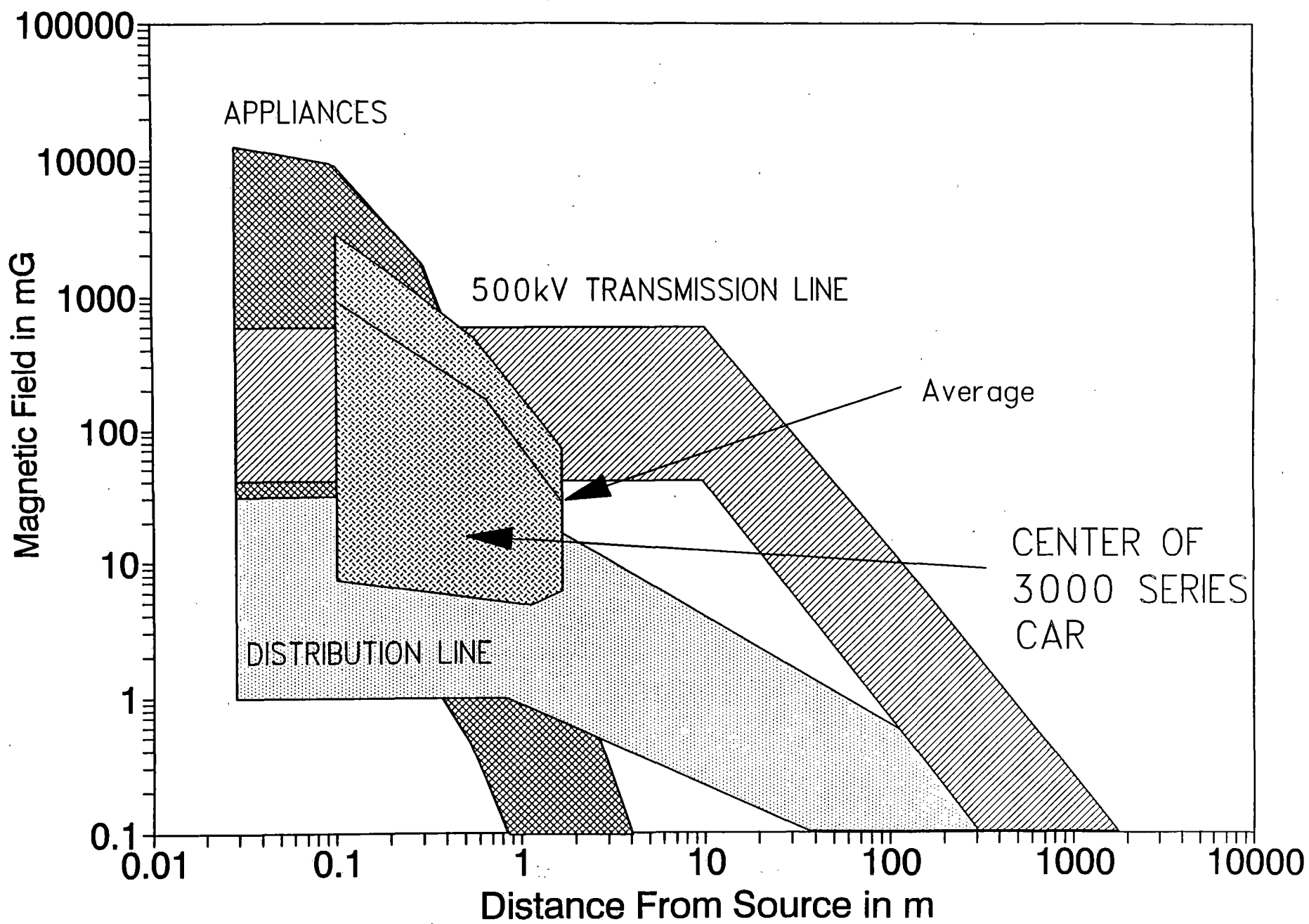

Figure 1-3 The range of total time varying magnetic field levels in the center of the 3000 series Metrorail cars compared to typical levels of power frequency magnetic fields produced by common sources.

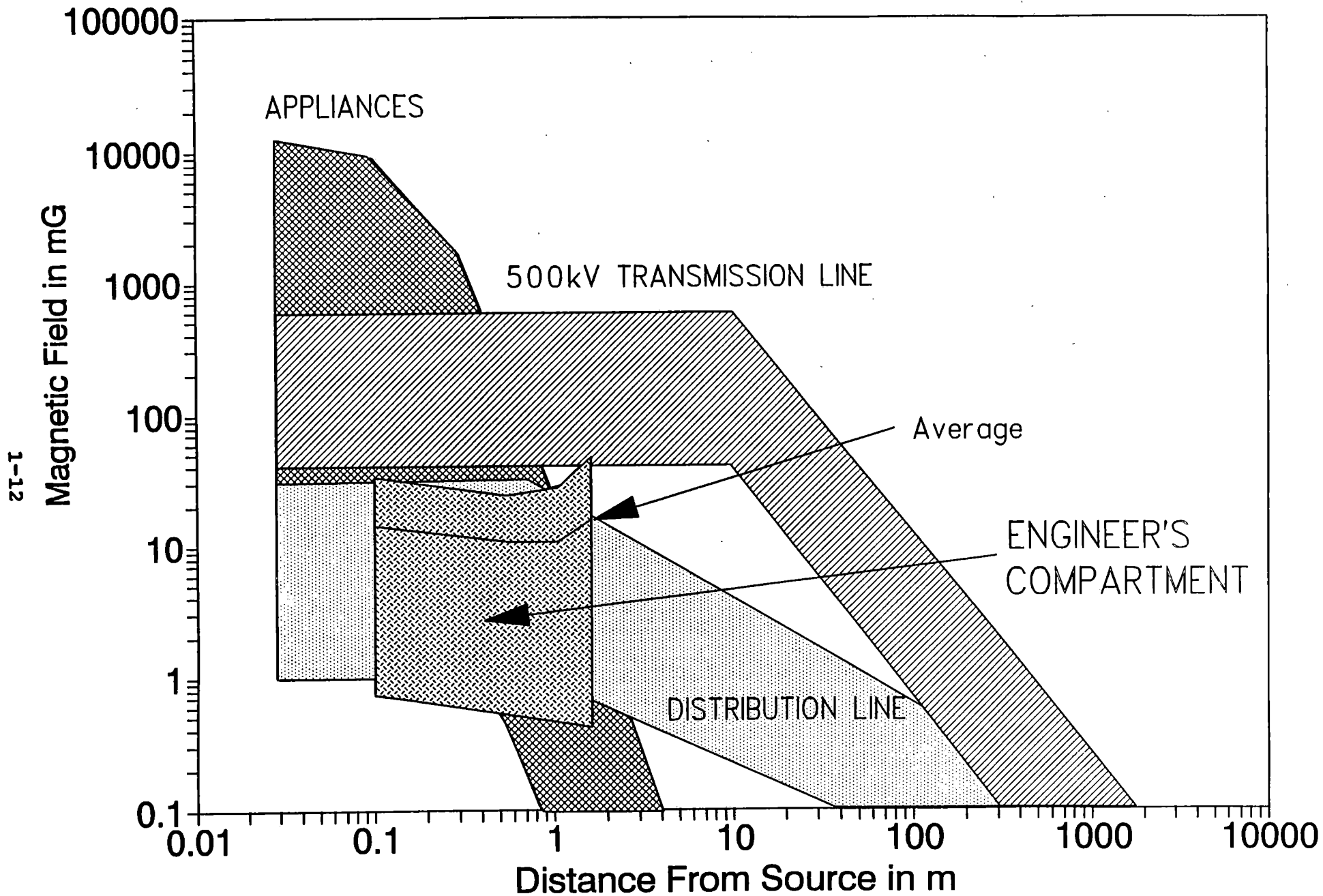

Figure 1-4

The range of total time varying magnetic field levels in the engineer's compartment of the Metrorail cars compared to typical levels of power frequency magnetic fields produced by common sources.

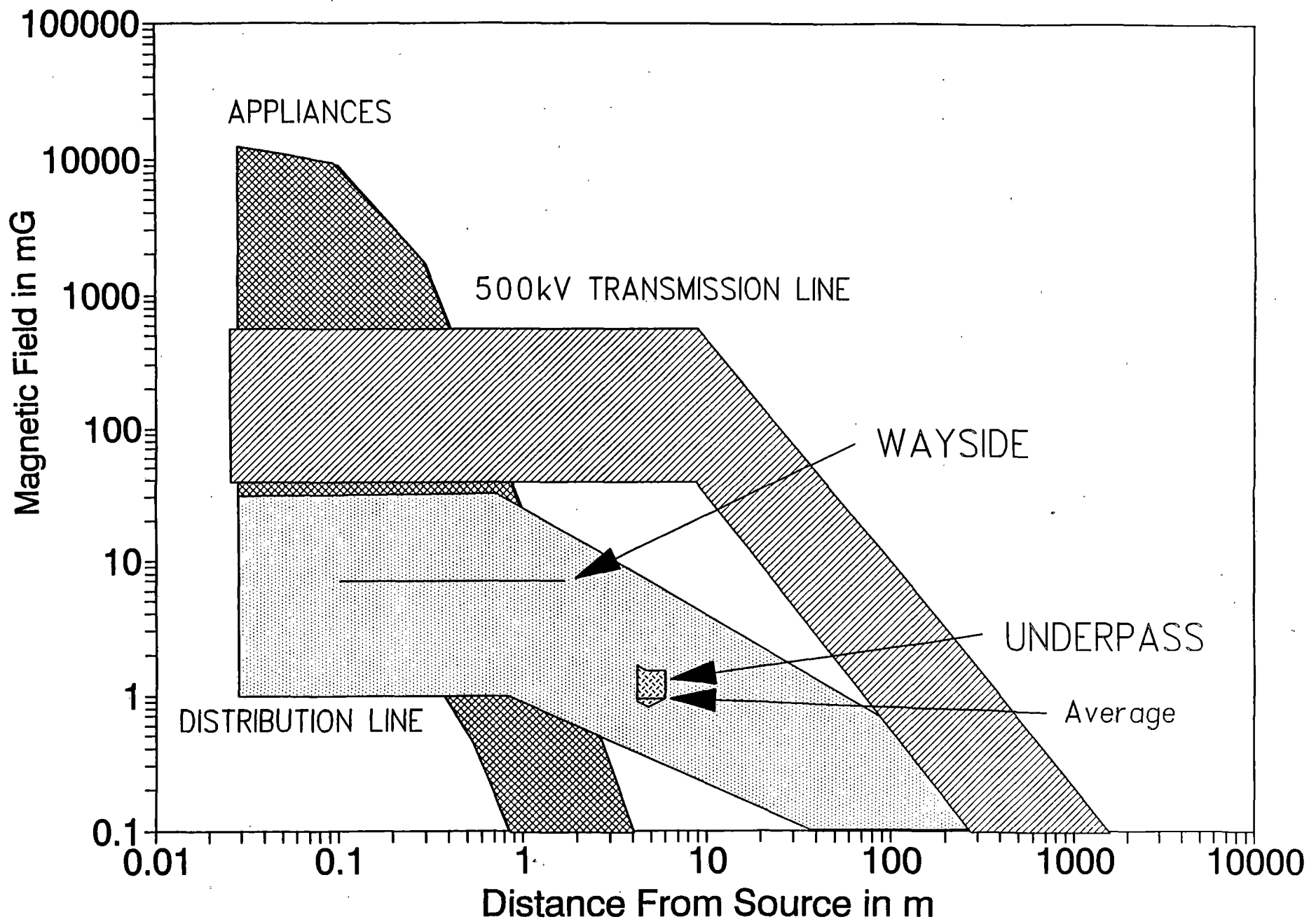

Figure 1-5 The range of total time varying magnetic field levels at a wayside and a highway underpass, at various distances from the nearest fence or track, compared to typical levels of power frequency magnetic fields produced by common sources.

1.4.4.4 Passenger Stations

The ranges of time varying magnetic fields measured on the Grosvenor outdoor and Gallery Place underground transfer passenger stations are shown in relation to other sources in Figure 1-6 (Figure 9-8 in the Conclusions). The distance to the source is the distance to the edge of the platform. The range of magnetic field levels at the platforms are slightly less than the general range of magnetic fields near distribution lines.

1.4.4.5 Power Supply System Measurements

The range of total time varying magnetic fields recorded at eight locations outside two different electric traction power supply stations is shown in Figure 1-7 (Figure 9-9 in the Conclusions). It can be seen that these field levels are in the range of fields found under distribution lines. The distance to the source is the distance to the fence or wall of the installation.

1.4.4.6 Control Areas

Figure 1-8 (Figure 9-10 in the Conclusions) shows the plot of the range of time varying magnetic fields in front of the dispatcher's VDT in the dispatcher's room. The distance to the source is the distance to the VDT screen. As one would expect, the figure shows that the range of magnetic field levels from the VDT is well within the range of magnetic fields near appliances. The flat part of the VDT field curve beyond 1 meter from the source represents the general background field level within the dispatcher's room. That background level is very modest compared to the range of field levels found near the three common field sources depicted in the figure.

1.5 Conclusions

The magnetic fields associated with the Metrorail System contain both static and time varying components. The dc traction current in the third rail, in the track return, in the power control equipment beneath the cars, and in the traction power supply station creates static fields in the vicinity of those facilities. The time varying magnetic fields associated with the Metrorail System are of two distinct types. First, changes in the "static" field level brought about by changes in the dc traction current in the aforesaid circuits produces low frequency time varying components that vary in intensity depending on the time rate of change of the static field. Secondly, there are periodic time varying components of the field arising from ripple in the dc traction current and from chopper current in the 3000 series cars.

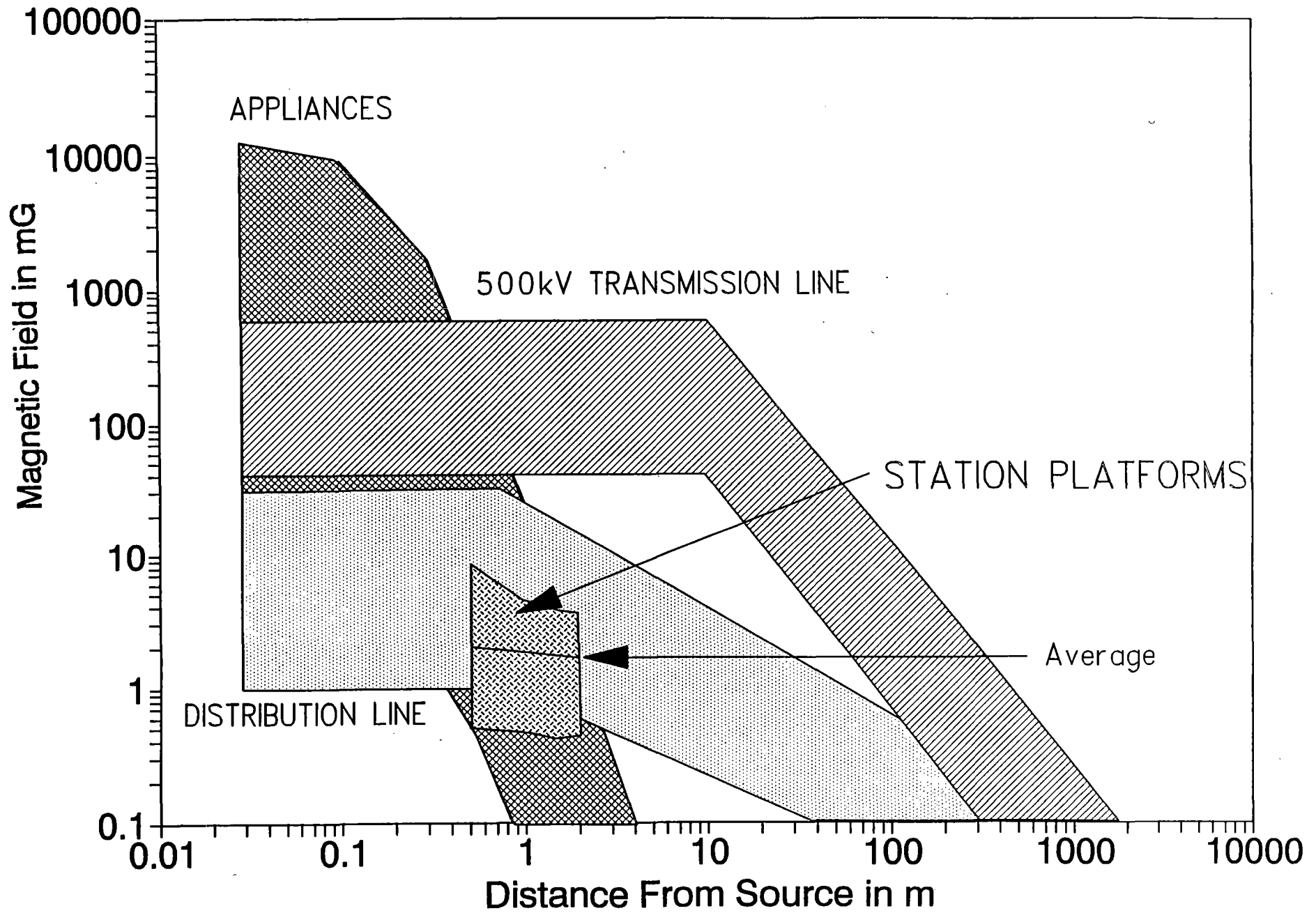

Figure 1-6 The range of total time varying magnetic field levels on the platforms, at various distances from the track, compared to typical levels of power frequency magnetic fields produced by common sources.

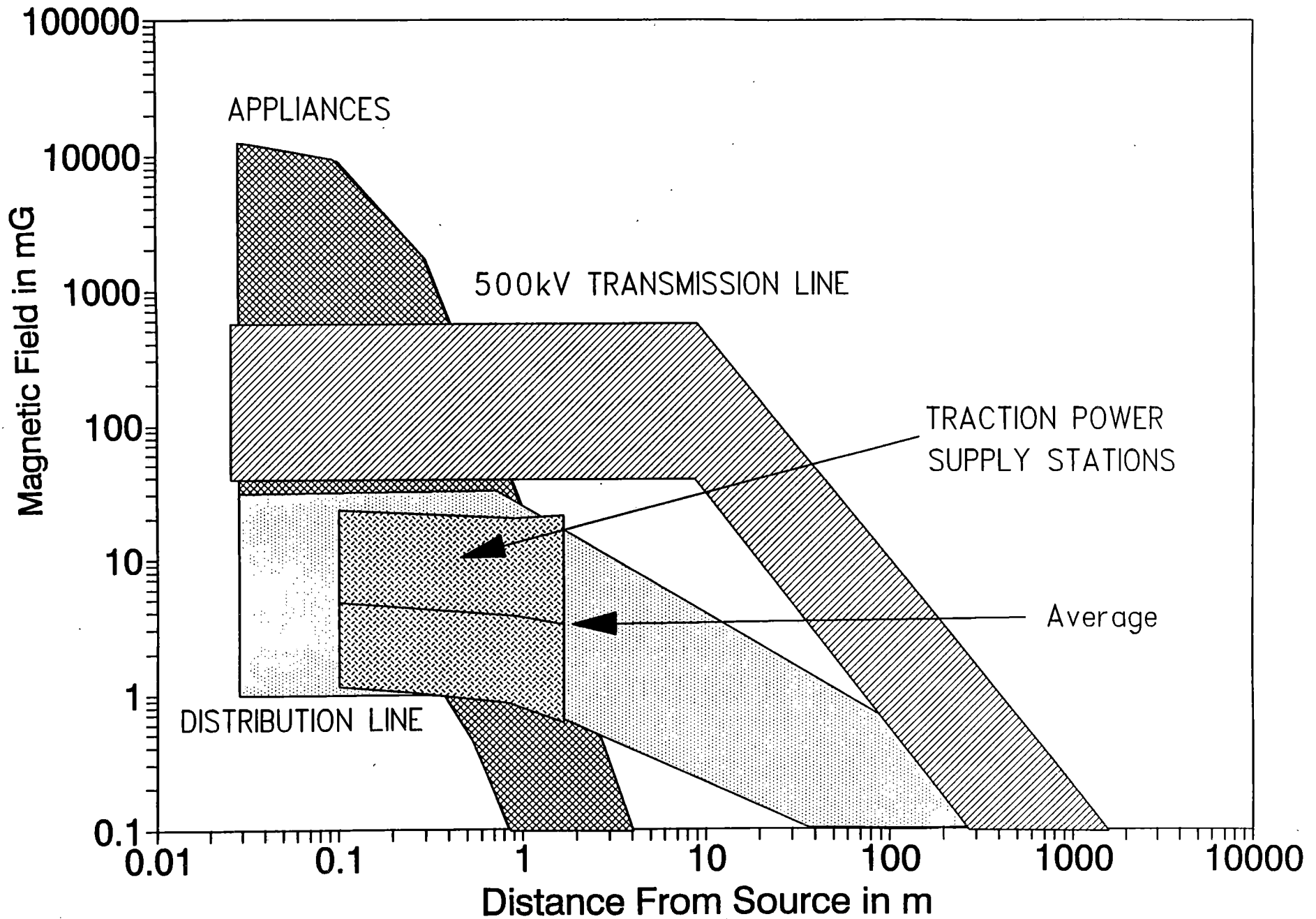

Figure 1-7

The range of total time varying magnetic field levels outside traction power supply stations, at various distances from the fence or wall, compared to typical levels of power frequency magnetic fields produced by common sources.

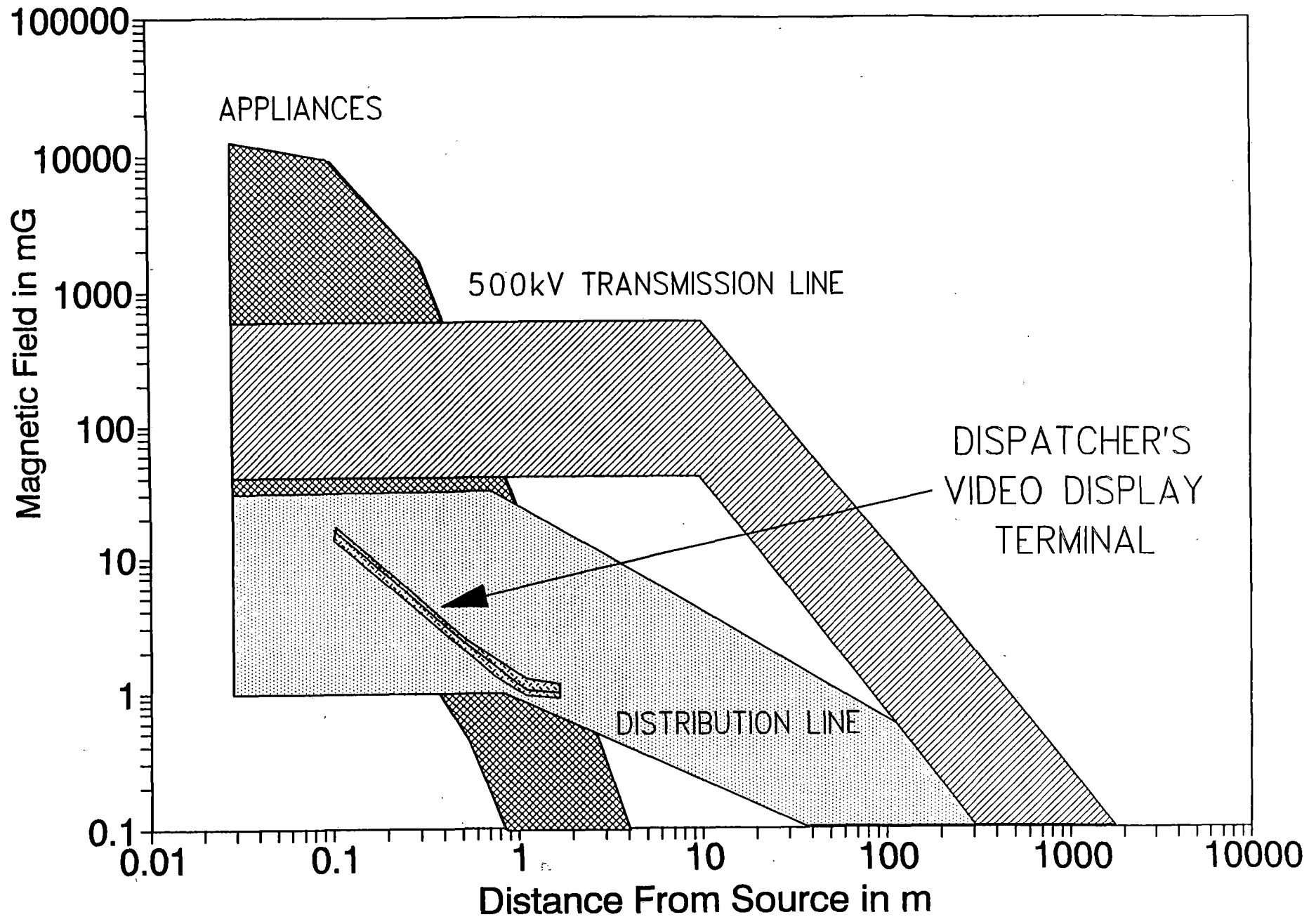

Figure 1-8

The range of total time varying magnetic field levels in front of a dispatcher's video display terminal compared to typical levels of power frequency magnetic fields produced by common sources.

Both static and time varying magnetic fields onboard the cars arise predominantly from the traction power control equipment beneath the floor and secondarily from the current loop formed by the third rail and the tracks. Because power needs of the cars are set by terrain and speed control, these fields are highly variable over time.

On station platforms, especially near the edge of the platform close to the rails, static and time varying magnetic fields arise both from the traction power (dc and rectification harmonics) and equipment onboard the passing trains. At the wayside locations the time varying magnetic fields also arise from rectification harmonics on the traction power however they were smaller than 60 Hz and harmonic fields from nearby power lines. Static field attributable to the Metrorail System could not be detected because they were smaller than the natural static field of the earth. Magnetic fields from equipment onboard the passing train were not found at the wayside location.

At traction power supply stations, measurements at the sides close to the ac electric equipment such as transformers and switchgear, yield 60 Hz and odd harmonic (mainly third harmonic) fields. At the dc, or output, side of the station, magnetic fields have the combined characteristics seen at the ac side of the station plus the static field and ripple-frequency fields seen at other places near the Metrorail tracks.

No significant electric fields were detected anywhere in the system. The largest fields, of the order of 7 V/m were found outside one electric traction power supply stations but appeared to arise from a nearby distribution line rather than the station. Along the wayside the fields measured approximately 5 V/m and in the passenger stations 2 V/m. As expected, electric fields of less than 1 V/m were detected inside the cars and the dispatcher's office, because of the shielding by the cars and the building structures. The predominant frequency of these fields was 60 Hz which indicates that the source was either nearby electric equipment or nearby electric distribution lines.

2.0 OVERVIEW

This report presents a quantification of the electric and magnetic fields associated with the Washington Metropolitan Area Transit Authority (WMATA) Metrorail System. It is one of a series of reports by Electric Research & Management, Inc. (ERM) for the Federal Railroad Administration (FRA) on the general characteristics of magnetic and electric fields associated with railroad systems. The previous reports have covered a number of different technologies. Specifically, measurements have been made and reported onboard the German Transrapid (TR07) Maglev System, AMTRAK diesel and electrified trains on the Northeast Corridor, electrified trains on the New Jersey Transit's North Jersey Coast Line from Matawan to Long Branch, and the French Train à Grande Vitesse (TGV). Electric and magnetic fields have also been measured and reported at the stations, along the wayside, at power supply facilities, and in control facilities for each of these transportation systems.

2.1 Report Organization

This report is organized into two volumes. The body of the report contained in Volume I focuses on the representative data and summarizes statistical data for the reader who is interested in overall system characteristics. The representative data demonstrate the general characteristics of the magnetic fields on or in the vicinity of the WMATA Metrorail System. The extensive appendices of Volume II detail the magnetic fields at specific locations on or near the Metrorail System for the reader looking for specific details of field characteristics.

The first section of this report is an executive summary intended for the less technically inclined reader. It describes the magnetic fields produced by the Washington Metrorail System and the conclusions reached by these measurements in language which avoids engineering jargon to the greatest extent practical. In spite of its non-technical nature, it is recommended to all readers as an orientation to the report contents and will assist the technical reader in critically examining the contents of the report.

This section is an overview which seeks to describe the report structure in more detail and direct the reader to other sources of relevant information not contained herein. It also seeks to provide some background information about the measurement program, describe instrumentation, explain the significance of the repetitive waveform data, the method of analysis, the format of presentation, and certain other items relevant to the report as a whole.

Sections 3 through 8 focus on the characteristics of the magnetic fields measured onboard the cars, within the engineer's

compartment, along the wayside, at passenger stations, near power supply facilities, and inside control facilities, respectively.

Section 9 of the report attempts to both summarize the magnetic field characteristics of the WMATA Metrorail System and compare these characteristics to magnetic fields produced by other common sources.

2.2 Background

The increasing public awareness of the controversy over possible health implications due to exposure to magnetic fields makes it desirable to quantify the magnetic fields associated with use or operation of all electrical apparatus. Previous measurements have characterized the magnetic fields associated with state-of-the-art transportation systems like the Transrapid TR07 magnetically levitated vehicle and the French TGV (Train à Grande Vitesse) electrified railroad system which holds the world's rail speed record of 515.3 kph (300 mph). Similar measurements have been made onboard AMTRAK electrified trains and near the facilities of the Northeast Corridor (NEC) to provide baseline magnetic field data on a conventional, historically well accepted transportation technology against which the magnetic field environment of emerging technologies may be compared. Additional magnetic field measurements have been made onboard trains and adjacent to facilities of the New Jersey Transit's North Jersey Coast Line from Matawan to Long Branch. That section of the railroad is electrified using somewhat newer technology. This report is on the WMATA Metrorail System which is characteristic of a modern urban mass transit system using 750 volts dc third rail technology.

To achieve the goal of fully quantifying the electromagnetic environment of the Metrorail System, an exhaustive set of measurements was made onboard trains, in the engineer's compartment, at passenger stations, along the wayside, in control facilities, and near power supply facilities. These measurements were made for a sampling of operating conditions. However, before the amplitude, time, and frequency characteristics of the fields are analyzed and presented, it is necessary to discuss some general background information on magnetic fields.

Natural Magnetic Field Characteristics. The earth's naturally-occurring geomagnetic field is generally considered to be static, i.e., not variable over time (in some literature, static fields are referred to as dc fields). The earth's field is normally static at levels between 240 milligauss in Southern Brazil to 670 milligauss at the magnetic South Pole. In any region of the earth's surface, fluctuations will occur during solar magnetic disturbances. These fluctuations normally have frequencies that are less than one hundredth of a cycle per second to as high as 1000 cycles per second. The magnitude of these fluctuations is normally largest at the lowest frequencies and in the polar regions. Mid-latitude

variations of 2 to 4 milligauss are common during strong solar storms. In polar regions, solar magnetic disturbances can cause greater than ± 20 milligauss fluctuations. Therefore, the natural environment is made up of magnetic fields with both spatial and temporal characteristics.

Technological Magnetic Field Perturbations. Man-made ferromagnetic structures and electro-technologies perturb these natural fields. In close proximity to building and vehicle steel, increases or decreases to the earth's unperturbed geomagnetic field of 2:1 are readily observed. Any electrical device that draws significant current for operation or uses magnetic material will create magnetic field intensities close to the device that are on the order of the naturally occurring magnetic fields. Most electrical devices in common usage are powered by alternating current (ac) sources. The magnetic fields produced have the frequency of the power source and tiny harmonics (sub or super) which result from the device's operating characteristics. On the North American continent, the dominant power source frequency is 60 cycles per second (the engineering and scientific communities have agreed to refer to cycles per second as hertz and to further shorten the reference by using the abbreviation Hz). In Europe most power systems are 50 Hz. Therefore, most electro-technology magnetic fields produced are primarily at these power frequencies. The magnitudes of the magnetic fields at the power frequencies range from fractions of milligauss in rural residences to tens of gauss near high current carrying conductors found in many commercial and industrial facilities. Many commonly used household appliances, such as high speed hair dryers and handheld drills, exhibit power frequency magnetic fields well above one gauss (one thousand mG) in close proximity to the appliance.

Electric and Magnetic Fields and Biological Effects. Since the late 1800s, electro-technologies have been perturbing the natural electromagnetic environment. In the early 1970s, the subject of electric fields surfaced as a possible health concern when electric utilities tried to gain rights-of-way for power transmission lines. Transmission lines were one of a small number of electro-technologies that produced strong power frequency electric fields where there was public access. The transmission lines at the center of the controversy were a new technology in that the operating voltage was 60% higher than previous design. The frequency characteristics were unchanged. While magnetic fields were raised as a biological issue in the 1970s because of a Navy submarine communications project, it was not until 1979 that magnetic fields appeared as a possible health concern. It was suggested that there was a weak correlation with an increased risk of childhood leukemia for populations living near distribution lines. While the first such study was considered to be technically flawed, two subsequent, improved epidemiological studies continued to find a consistent pattern when a surrogate for magnetic fields, power lines with large conductors and proximity to the cases, were

documented. In 1992 Swedish researchers reported on finding a somewhat stronger association for childhood leukemia among children living in close proximity to transmission lines in Sweden. Starting with the assertion of biological effects from electric fields and redoubled with emergence of the magnetic field effect hypothesis, laboratory scientists have reported many electric and magnetic field effects found by *in vitro* (tissue culture preparations) and *in vivo* (whole animal studies) experiments.

Many of the laboratory studies and a concurrent body of clinical studies have reported effects which appear to result from exposure to fields with a wide range of magnitudes and frequencies. To explain these observations, hypotheses such as "cyclotron resonance" which links the co-existence of static (dc) and ac fields have been offered. Because much of the political controversy has been focused on determining if transmission lines can be cited, most of the laboratory effort has been directed at the very selective power frequencies, 50 and 60 Hz. Yet many reported results have little to do with the power frequencies. Many studies report findings in the few hertz to tens of hertz frequency band. There are reports of findings when the exposure repetition rate was above the power frequencies. Some studies suggest the duration of exposure is important. Some studies suggest that both intensity (magnitude) and frequency windows exist, i.e., above or below a certain region no effect is observed. Some studies suggest that the transition from one field level to another is important, others debate whether magnetic fields act directly on the body or via induced currents. Few of these studies have been replicated and no accepted mechanism of interaction of environmentally relevant electric or magnetic field exists.

In the absence of an accepted mechanism, many have chosen to relegate the reported effect of electric and magnetic fields to the category of "pathological science" (a term coined by the late Irving Langmuir). However, the persistence of public concern necessitates that any serious attempt at magnetic field quantification which claims to serve as a basis for evaluating possible health effects must not be an inadvertently selective measure of magnitude at a single or narrow band of frequencies. In the extreme, if health effects are found, the continuum of electromagnetic exposure may be required to establish relative risk. Practically, it has only recently become possible to record and store all of the discrete segments of frequency bands which biological reports suggest may be important. Based on the biological studies reported to 1992, the electrified railroad measurements focused on the 0 to 2500 Hz portion of the electromagnetic spectrum.

2.3 The WMATA Metrorail System

This study concentrates on the characteristics of the Washington Metropolitan Area Transit Authority (WMATA) Metrorail System that

provides urban mass transit to the greater Washington, DC metropolitan area. The measurements were taken on portions of the Red Line between Shady Grove and Van Ness-UDC Stations and the Green Line between Gallery Place-Chinatown and U Street-Cardozo Stations.

There are three types (generations) of cars in service on the WMATA Metrorail System: the 1000, 2000 and 3000 series. They are of different manufacture. Two different traction power control technologies are employed.

1000 Series	Rohr Industries, Inc	DC "CAM" Control
2000 Series	Breda Transportation, Inc	DC "CAM" Control
3000 Series	Breda Transportation, Inc	DC Semiconductor Chopper Control

Each car is self propelled by a Westinghouse propulsion system and has two sets of dc traction motors that are connected to each axle. Load sensors in each car control the power of each car so that they do not try to pull or push one another. The cars come in two varieties, the A and the B, which always operate in "married" pairs. The A car carries the air compressor unit, whereas the B car carries the battery and the converter units. Since the cars are always paired, the train sets always contain an even number of cars.

Although all three series of cars on the Metrorail System have Westinghouse propulsion systems, two different traction power control technologies are used to regulate the amount of electrical power provided to the traction motors. CAM control, used on the 1000 and 2000 series cars, means that resistors are switched in and out of either the armature or field of the motors in order to control their speed and torque. Similarly, resistors are switched in to provide dynamic braking. All of the resistors and associated switches are located beneath the cars between the two trucks. On the other hand, the 3000 series cars use chopper control to accomplish the same goals via voltage control. These semiconductor choppers operate at a fixed frequency of 273 Hz and control the power applied to the traction motors by varying the on duty cycle (the percentage of time that the semiconductor is turned on during each 3.7 ms chopper cycle). Reactors are provided before and after the chopper to filter or "smooth out" some of the chopper ripple in the line and motor currents, respectively. This type of control allows regenerative braking capability which reverses power flow back into the supply system in addition to normal dynamic braking. Again, all of this traction power control equipment is located beneath the cars in the central area between the trucks. Of particular note, from a magnetic field point of view, is the large line smoothing reactor directly under the floor in the center of each 3000 series chopper controlled car. All of the current drawn by the traction motors of the car must pass through that large

multi-turn coil. Since the reactor has only a short iron core in the center of the coil, all of the magnetic flux passing through the center of the reactor coil must pass through the air and other non-ferromagnetic material around the outside of the reactor in order to close the flux path from one end of the core to the other. Consequently, an appreciable portion of that magnetic flux will pass through the central portion of the passenger area of the 3000 series car.

The electrical power supply system of the train is 750 volts dc through the third rail. This supply is produced by converting 60 Hz ac power from commercial utility sources to dc power through rectification at a series of traction power supply stations distributed every few miles along the Metrorail lines. These traction power supply stations contain transformers, rectifiers, switchgear, and filter capacitors which convert the incoming three-phase 60 Hz power supplied at distribution voltages (typically 13.8 kV) into the 750 volts dc that is applied to the third rail to supply power to the train. The dc current is then collected from the third rail through contactor shoes on the front and back trucks of the cars. The dc current flows through under-car wiring to the under-car power control equipment (either CAM or electronic chopper) and to the dc traction motors on the trucks before returning to traction power station ground via the wheels and track.

2.4 An Approach to Organizing Electromagnetic Data

The magnetic field environment over the desired frequency range from 0 to 2500 Hz can be efficiently recorded with excellent resolution using the *MultiWave*™ Recording System described in the following subsection. Unlike most systems which merely report the total magnetic field over their frequency range, the *MultiWave*™ System was operated during the railroad tests in a manner which detects the magnetic field in very narrow frequency bands across the spectrum from 0 to 2500 Hz. The effective frequency resolution of these data is 1 Hz increments from 0 to 100 Hz and 5 Hz increments from 5 to 2500 Hz.

The data collected in this manner brackets most of the frequency bandwidth implicated by the biological findings discussed briefly above. Both temporal and spatial quantification of the magnetic field in and around the Metrorail System are available. Because each of these measurements was repeated every few seconds to gain a measure of the long term temporal characteristics of the magnetic fields, a large, as well as comprehensive, dataset exists. The challenge of this report, as in the other reports of the series, has been to reduce this data without losing the uniqueness of the information. Also to maximize the utility of the data, it must be presented so that it can be compared to data collected on the magnetic field characteristics of other electro-technologies.

To this end, the following aggregation was chosen for this evaluation. It is also being followed in an ongoing project to establish a rigorous protocol for quantifying the magnetic fields associated with appliances. Shown in pictorial form in Figure 2-1, this system allows for the grouping of data into frequency bands where effects have been reported and/or other datasets have been collected. The two large boxes depict the frequency regions defined by IEEE Std 100-1988⁷ as Ultra Low Frequency (ULF), which covers the frequency range from 3 Hz down to static, and Extreme Low Frequency (ELF), which covers the frequency band from 3 Hz to 3000 Hz. Other organizations and agencies sometimes define these bands differently, but the IEEE definitions will be used throughout this report. The boxes within the large boxes depict the partitioning which was chosen to present clearly, but succinctly, the findings of these WMATA Metrorail System measurements.

The partitioning in Figure 2-1 also allows for comparison with data collected by less sophisticated instruments. In particular, the EMDEX-II which has come into wide use in the utility industry has a 3 dB bandwidth between 40 Hz and 800 Hz, mainly the power frequency and some harmonics. Other survey meters only respond to the power frequency band.

2.5 Instrumentation

The principal instrumentation system used for magnetic field measurements on the electrified railroads was a portable version of the *MultiWave*[™] recorder. The *MultiWave*[™] System was augmented with a digital audio tape (DAT) recorder to obtain a continuous record of magnetic field levels at one location. EMDEX-II personal exposure monitors were also used to document the significance of personnel movement throughout the train. Additionally, an electric field meter was used for some of the tests.

Portable *MultiWave*[™] System

The portable *MultiWave*[™] Recording System used in the tests reported herein is a version of the *MultiWave*[™] recorder used for the Transrapid TR07 measurements, as optimized for measurements on transportation systems. The magnetic field waveform recording approach utilized by the *MultiWave*[™] System has already been reported¹. The portable version configured for transportation system measurements employs the same measurement philosophy and uses software nearly identical to the standard *MultiWave*[™] software but has a number of enhancements³.

The portable *MultiWave*[™] System was operated throughout the Washington Metro System tests in modes which produce data directly comparable to the data obtained on the Transrapid TR07 Maglev System, the NEC and the French TGV. Hence the results reported previously for the

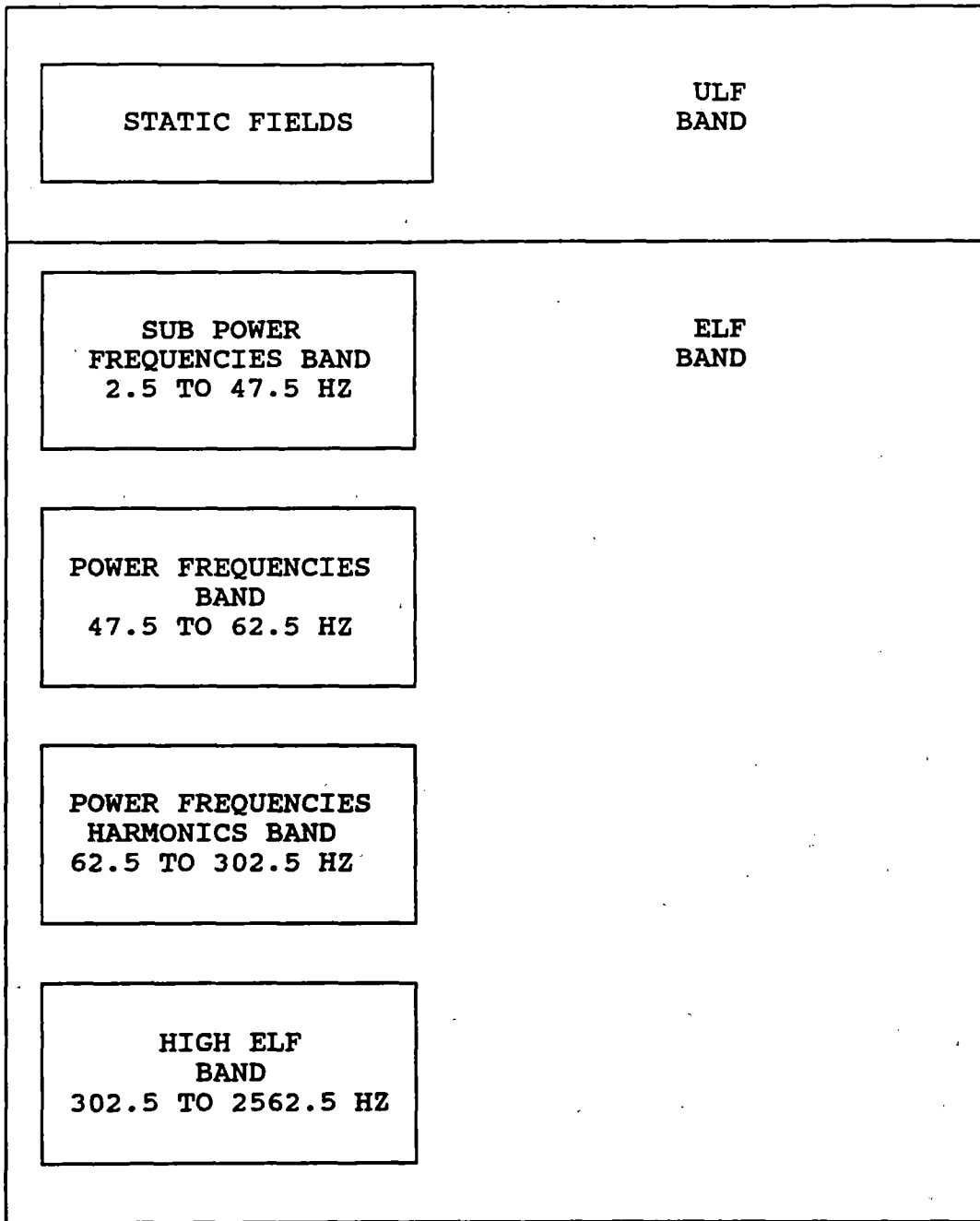

Figure 2-1 Magnetic field flux densities grouped by frequency partitions within the ELF band and ULF band.

TR07 System^{1,2}, the NEC³ and the TGV⁴ can be compared directly to the results reported herein for the WMATA Metrorail System.

Digital Audio Tape Recorder

The *MultiWave*[™] Recording System is a sampling-type recording system in the sense that it records the magnetic field environment in great detail for a brief period of time (0.2 to 1.0 seconds) then pauses for a period of time (5 to 60 seconds) before initiating another detailed sample. Hence, there is a possibility that the *MultiWave*[™] System could miss capturing brief events such as rapid field transients if they are very rare. In order to determine whether the sampling recording system was failing to capture rare short-term events, a TEAC Model RD 130T digital audio tape recorder (DAT) was connected to the analog output port of the *MultiWave*[™] System's reference probe. This permitted the DAT to make continuous recordings of the three-axis field (0-2500 Hz, 6 gauss full scale) at the reference probe. Three additional channels of the DAT made continuous recordings of the ac field (3-2500 Hz) amplified by a factor of ten or more to ensure enough resolution for accurate recording of the higher frequency components.

EMDEX-II Recorders

The Electric and Magnetic Digital Exposure (EMDEX) meters developed for the Electric Power Research Institute (EPRI) are convenient and useful instruments for monitoring personal exposure to ELF magnetic fields from power systems. Their broadband response is nominally 40 to 800 Hz, which is adequate to capture the fundamental and low order harmonic components of the magnetic fields from 50 Hz or 60 Hz power systems. Unfortunately, the pass band of the EMDEX-II meter is not sufficient to capture either the static or the low frequency time varying fields found near dc-powered transportation systems. Furthermore, the upper frequency limit of the EMDEX-II is not sufficient to capture many of the harmonics of the chopper frequency encountered in the WMATA Metrorail System. Nevertheless, the EMDEX-II recorders have been used throughout the measurement programs as personal exposure monitors to determine the extent to which stationary field measurements correlate with exposure of a passenger moving throughout the train or in a surrounding area.

2.6 Repetitive Waveform Data

As described in the preceding reports^{2,3,4}, the *MultiWave*[™] Magnetic Field Recording System records the actual waveform of the three orthogonal components of the magnetic field at multiple measurement locations by sampling those waveforms at a high rate and storing the values digitally on computer disk or computer tape. These digital waveform recordings are saved one after another in rapid succession. Any one of these waveform recordings can be viewed individually in either the time or frequency domain to get a

"snapshot view" of the waveform or frequency spectrum of the magnetic field at the particular instant in time when the waveform sample was recorded. These "snapshots", when viewed individually, have little statistical validity and tell nothing about the evolution of magnetic field characteristics over time as the train speeds up, slows down, makes use of its dynamic braking, passes the station, and so on. In order to examine these questions of statistical and temporal variability of the magnetic field, many of these "snapshots" must be played back in rapid succession to produce a "moving picture" of the magnetic field at each measurement location.

As described in later sections of the report, the measurement protocol applied for the electrified railroad measurements generally involved the use of five fluxgate magnetic field (B) sensors arrayed in such a way that spatial variability of the magnetic field could be characterized. Since magnetic fields onboard or near the train can arise from numerous sources, each with different temporal characteristics, the spatial pattern of the magnetic field is a dynamic characteristic which must be assessed from the "moving picture" of the magnetic field obtained from analysis of the repetitive waveform samples.

A list of the repetitive waveform datasets collected during the measurements on the WMATA Metrorail System is given in Table 2-1. The table also identifies the nature of the measurement, the measurement time, and the sample time for each of the 52 datasets. Table 2-1 also gives numerical codes for sensor locations (indicating also the figure which illustrates staff and reference probe locations) which are described in more detail later in the report. The analysis method applied to these repetitive waveform datasets is described in detail in a previous report. The information contained in each of the 52 datasets has been processed using that procedure and is presented in detail in Appendices B through AZ in Volume II of this report.

2.7 DAT Waveform Data

Three-axis magnetic field waveforms from the *MultiWave*™ reference sensor were recorded using the digital audio tape recorder. Two recordings were made of each orthogonal component (axis) of the field: one of the signal directly from the magnetometer; and a second of the signal with the static component filtered out and the time varying components amplified (usually by a factor of ten) to provide better resolution of higher frequency components. Approximately 2.5 hours of recordings were produced for the test conditions reported in Table 2-2.

The continuous recordings of magnetic field waveform were reviewed for any transient magnetic field conditions which might exist. The type of analysis conducted on the DAT data was to construct time

course plots of the magnetic field over the time of the recordings. These results were compared to the corresponding data from the portable *MultiWave*™ System to determine whether the data sampling procedure of the *MultiWave*™ lost any significant data which is obtainable by continuous monitoring.

2.8 EMDEX-II Data

Several EMDEX-II recordings were made by members of the measurement crew while traveling on the Metro Line or working at the stations, wayside, or power supply facilities. These data are compared and contrasted with the *MultiWave*™ System and DAT data.

TABLE 2-1

INDEX OF REPETITIVE WAVEFORM DATA
 WMATA METRORAIL
 MAY 19 - MAY 20, 1992

DATA FILE NUMBER	APPENDIX CONTAINING DATA	DATE/TIME	PROBE LOCATION FIG. STAFF REF.			SAMPLE INTERVAL, SECONDS	NUMBER OF SAMPLES	LOCATION AND TYPE OF MEASUREMENT
		MAY 19						
MET001	B	08:25-08:29	3-1	1	-	5	18	CENTER OF AISLE IN CENTER OF CAR #1173 ON RED LINE. STAFF IN VERTICAL POSITION.
MET002	C	08:32-08:35	3-1	5	10	5	14	CENTER OF AISLE AT REAR OF CAR #1173 ON RED LINE. STAFF IN VERTICAL POSITION.
MET003	D	08:36-08:40	3-1	8	10,11	5	27	IN FRONT OF OPERATOR'S SEAT AT REAR OF CAR #1173 ON RED LINE. STAFF IN VERTICAL POSITION.
MET004	E	10:00-10:00	3-1	1	-	5	2	CENTER OF AISLE IN CENTER OF CAR #3012 ON RED LINE. STAFF IN VERTICAL POSITION.
MET006	F	10:04-10:05	3-1	1	9	5	10	SAME POSITION AS MET004.
MET007	G	10:07-10:09	3-1	1	9	5	12	SAME POSITION AS MET004.
MET008	H	10:12-10:15	3-1	5	11	5	16	CENTER OF AISLE AT REAR OF CAR #3012 ON RED LINE. STAFF IN VERTICAL POSITION.

TABLE 2-1 (CONT.)

DATA FILE NUMBER	APPENDIX CONTAINING DATA	DATE/ TIME	PROBE LOCATION			SAMPLE INTERVAL, SECONDS	NUMBER OF SAMPLES	LOCATION AND TYPE OF MEASUREMENT
			FIG.	STAFF	REF.			
MET009	I	10:16- 10:18	3-1	8	11	5	10	IN FRONT OF OPERATOR'S SEAT AT REAR OF CAR #3012 ON RED LINE. STAFF IN VERTICAL POSITION.
MET010	J	10:18- 10:20	3-1	6	10	5	13	REAR OF CAR #3012 ON RED LINE. STAFF IN HORIZONTAL POSITION ALONG THE AXIS OF THE CAR WITH THE REAR DOOR AS THE REFERENCE.
MET011	K	10:21- 10:22	3-1	7	10	5	10	REAR OF CAR #3012 ON RED LINE. STAFF IN HORIZONTAL POSITION TRANSVERSE TO THE AXIS OF THE CAR WITH CENTER OF AISLE AS THE REFERENCE.
MET012	L	10:34- 10:35	3-1	3	-	5	9	CENTER OF CAR #3090 ON RED LINE. STAFF IN HORIZONTAL POSITION TRANSVERSE TO THE AXIS OF THE CAR WITH CENTER OF AISLE AS THE REFERENCE.
MET013	M	10:35- 10:38	3-1	2	-	5	18	CENTER OF CAR #3090 ON RED LINE. STAFF IN HORIZONTAL POSITION ALONG THE AXIS OF THE CAR WITH THE CENTER OF THE CAR AS THE REFERENCE.
MET014	N	10:39- 10:40	3-1	4	-	5	6	NEAR DOORS AT LEFT CENTER OF CAR #3090 ON RED LINE. STAFF IN VERTICAL POSITION.

TABLE 2-1 (CONT.)

DATA FILE NUMBER	APPENDIX CONTAINING DATA	DATE/TIME	PROBE LOCATION			SAMPLE INTERVAL, SECONDS	NUMBER OF SAMPLES	LOCATION AND TYPE OF MEASUREMENT
			FIG.	STAFF	REF.			
MET015	O	10:56-10:57	6-1	16	17	5	11	ON DEPARTING END OF NORTH BOUND SIDE OF GROSVENOR STATION PLATFORM AT SAFETY LINE. STAFF IN VERTICAL POSITION.
MET017	P	11:00-11:02	6-1	18	19	5	23	ON ARRIVING END OF SOUTH BOUND SIDE OF GROSVENOR STATION PLATFORM AT SAFETY LINE. STAFF IN VERTICAL POSITION.
MET018	Q	11:05-11:08	6-1	20	17	5	34	ON ARRIVING END OF GROSVENOR STATION PLATFORM AT SAFETY LINE. STAFF IN HORIZONTAL POSITION 1 METER ABOVE PLATFORM WITH SAFETY LINE AS REFERENCE.
MET019	R	11:10-11:11	6-1	21	-	5	6	AT GROSVENOR STATION, BOTTOM OF ESCALATOR. STAFF IN VERTICAL POSITION.
MET021	S	11:16-11:17	6-1	22, 23	-	5	13	AT GROSVENOR STATION, UP AND DOWN THE ESCALATOR. STAFF IN VERTICAL POSITION WITH ESCALATOR STEP AS REFERENCE.
MET022	T	11:20-11:21	6-1	24	25	5	11	CENTER OF GROSVENOR STATION PLATFORM AT SAFETY LINE. STAFF IN VERTICAL POSITION.
MET024	U	11:24-11:25	6-1	24	25	5	10	SAME AS MET022.

TABLE 2-1 (CONT.)

DATA FILE NUMBER	APPENDIX CONTAINING DATA	DATE/TIME	PROBE LOCATION			SAMPLE INTERVAL, SECONDS	NUMBER OF SAMPLES	LOCATION AND TYPE OF MEASUREMENT
			FIG.	STAFF	REF.			
MET025	V	11:27-11:31	6-1	26	27	5	41	CENTER OF GROSVENOR STATION PLATFORM. STAFF IN HORIZONTAL POSITION WITH SAFETY LINE AS REFERENCE.
MET026	W	15:31-15:33	3-1	8	-	5	9	IN FRONT OF OPERATOR'S SEAT AT REAR OF A 2000 SERIES CAR ON GREEN LINE. STAFF IN VERTICAL POSITION.
MET027	X	15:34-15:35	3-1	5	-	5	11	CENTER OF AISLE AT REAR OF A 2000 SERIES CAR ON GREEN LINE. STAFF IN VERTICAL POSITION.
MET028	Y	15:38-15:41	3-1	1	-	5	24	CENTER OF AISLE IN CENTER OF A 2000 SERIES CAR ON GREEN LINE. STAFF IN VERTICAL POSITION.
MET029	Z	15:41-15:42	3-1	2	-	5	7	CENTER OF A 2000 SERIES CAR ON GREEN LINE. STAFF IN HORIZONTAL POSITION ALONG THE AXIS OF THE CAR WITH THE CENTER OF THE CAR AS THE REFERENCE.
MET030	AA	15:43-15:43	3-1	3	-	5	4	CENTER OF A 2000 SERIES CAR ON GREEN LINE. STAFF IN HORIZONTAL POSITION TRANSVERSE TO AXIS OF THE CAR WITH CENTER OF AISLE AS THE REFERENCE.
MET031	AB	15:49-15:51	6-2	28	-	5	26	ON SOUTH BOUND SIDE OF GALLERY PLACE GREEN/YELLOW LINE PLATFORM. STAFF IN VERTICAL POSITION AT PLATFORM EDGE.

TABLE 2-1 (CONT.)

DATA FILE NUMBER	APPENDIX CONTAINING DATA	DATE/TIME	PROBE LOCATION			SAMPLE INTERVAL, SECONDS	NUMBER OF SAMPLES	LOCATION AND TYPE OF MEASUREMENT
			FIG.	STAFF	REF.			
MET032	AC	15:52-15:53	6-2	30	-	5	15	ON SOUTH BOUND SIDE OF GALLERY PLACE GREEN/YELLOW LINE PLATFORM. STAFF IN HORIZONTAL POSITION WITH EDGE OF PLATFORM AS THE REFERENCE.
MET033	AD	15:56-15:58	6-2	31	-	5	11	ON NORTH BOUND SIDE OF GALLERY PLACE GREEN/YELLOW LINE PLATFORM. STAFF IN VERTICAL POSITION AT PLATFORM EDGE.
MET034	AE	15:59-16:01	6-2	33	-	5	16	ON NORTH BOUND SIDE OF GALLERY PLACE GREEN/YELLOW LINE PLATFORM. STAFF IN HORIZONTAL POSITION WITH EDGE OF PLATFORM AS THE REFERENCE.
MET035	AF	16:05-16:05	6-2	34	-	5	4	ON MEZZANINE AT GALLERY PLACE STATION. STAFF IN VERTICAL POSITION DIRECTLY OVER CENTER GREEN/YELLOW LINE TRACK.
MET037	AG	16:11-16:13	6-2	35	-	5	18	SAME AS MET035.
		MAY 20						
MET038	AH	08:39-08:42	7-1	36	-	5	38	TRACTION POWER SUPPLY STATION SOUTH OF SHADY GROVE. STAFF IN HORIZONTAL POSITION 1 METER ABOVE GROUND WITH NORTH WALL AS THE REFERENCE.

TABLE 2-1 (CONT.)

DATA FILE NUMBER	APPENDIX CONTAINING DATA	DATE/TIME	PROBE LOCATION FIG. STAFF REF.			SAMPLE INTERVAL, SECONDS	NUMBER OF SAMPLES	LOCATION AND TYPE OF MEASUREMENT
MET039	AI	08:44-08:48	7-1	38	-	5	38	TRACTION POWER SUPPLY STATION SOUTH OF SHADY GROVE. STAFF IN HORIZONTAL POSITION 1 METER ABOVE GROUND WITH WEST WALL AS THE REFERENCE.
MET040	AJ	08:50-08:56	7-1	40	-	5	62	SAME AS MET039.
MET041	AK	08:59-09:02	7-1	42	-	5	39	SAME AS MET039.
MET042	AL	09:05-09:09	7-1	44	-	5	37	TRACTION POWER SUPPLY STATION SOUTH OF SHADY GROVE. STAFF IN HORIZONTAL POSITION 1 METER ABOVE GROUND WITH SOUTH WALL AS THE REFERENCE.
MET043	AM	09:42-09:45	7-2	46	-	5	38	SHADY GROVE TRACTION POWER SUPPLY STATION. STAFF IN HORIZONTAL POSITION WITH SOUTH EDGE OF FENCE AS THE REFERENCE.
MET044	AN	09:53-09:57	7-2	48	-	5	38	SHADY GROVE TRACTION POWER SUPPLY STATION. STAFF IN HORIZONTAL POSITION WITH SOUTH WALL OF BRICK BUILDING AS THE REFERENCE.
MET045	AO	10:01-10:05	7-2	50	-	5	43	SHADY GROVE TRACTION POWER SUPPLY STATION. STAFF IN HORIZONTAL POSITION WITH WEST WALL OF BRICK BUILDING AS THE REFERENCE.

TABLE 2-1 (CONT.)

DATA FILE NUMBER	APPENDIX CONTAINING DATA	DATE/ TIME	PROBE LOCATION			SAMPLE INTERVAL, SECONDS	NUMBER OF SAMPLES	LOCATION AND TYPE OF MEASUREMENT
			FIG.	STAFF	REF.			
MET046	AP	11:11- 11:12	8-1	52	-	5	19	IN THE DISPATCHER'S ROOM AT SHADY GROVE. STAFF IN VERTICAL POSITION AT DISPATCHER'S CHAIR.
MET047	AQ	11:13- 11:15	8-1	53	-	5	19	IN THE DISPATCHER'S ROOM AT SHADY GROVE. STAFF IN HORIZONTAL POSITION 1.25 METERS ABOVE FLOOR WITH MONITORS AS THE REFERENCE.
MET048	AR	11:15- 11:17	8-1	54	-	5	18	IN THE DISPATCHER'S ROOM AT SHADY GROVE. STAFF IN HORIZONTAL POSITION 1.25 METERS ABOVE FLOOR WITH MOCK-UP PANEL AS THE REFERENCE.
MET049	AS	12:05- 12:07	3-1	1	-	5	34	CENTER OF AISLE IN CENTER OF A 3000 SERIES CAR ON RED LINE FROM ROCKVILLE. STAFF IN VERTICAL POSITION.
MET050	AT	12:08- 12:08	3-1	2	-	5	11	CENTER OF A 3000 SERIES CAR. STAFF IN HORIZONTAL POSITION AT FLOOR LEVEL ALONG THE AXIS OF THE CAR.
MET051	AU	12:10- 12:10	3-1	3	-	5	9	CENTER OF A 3000 SERIES CAR ON RED LINE. STAFF IN HORIZONTAL POSITION AT FLOOR LEVEL TRANSVERSE TO THE AXIS OF THE CAR.
MET052	AV	12:11- 12:11	3-1	3	-	5	3	CENTER OF A 3000 SERIES CAR ON RED LINE. STAFF IN HORIZONTAL POSITION 1 METER ABOVE THE FLOOR, TRANSVERSE TO THE AXIS OF THE CAR.

TABLE 2-1 (CONT.)

DATA FILE NUMBER	APPENDIX CONTAINING DATA	DATE/ TIME	PROBE LOCATION			SAMPLE INTERVAL, SECONDS	NUMBER OF SAMPLES	LOCATION AND TYPE OF MEASUREMENT
			FIG.	STAFF	REF.			
MET053	AW	12:11- 12:14	3-1	2	-	5	28	CENTER OF A 3000 SERIES CAR. STAFF IN HORIZONTAL POSITION 1 METER ABOVE THE FLOOR, ALONG THE AXIS OF THE CAR.
MET054	AX	14:17- 14:28	5-1	12	-	5	133	BENEATH METRORAIL AT HIGHWAY UNDERPASS NEAR ROCKVILLE. STAFF IN VERTICAL POSITION.
MET055	AY	14:33- 14:33	5-1	12	-	5	6	SAME AS MET054.
MET056	AZ	14:53- 14:57	5-2	14	-	5	15	ALONG WAYSIDE 2 3/4 MILES SOUTH OF ROCKVILLE. STAFF IN A HORIZONTAL POSITION 1 METER ABOVE GROUND WITH FENCE AS THE REFERENCE.

TABLE 2-2

INDEX OF CONTINUOUS WAVEFORM (DAT) DATA
 WMATA METRORAIL MEASUREMENTS
 MAY 19 & 20, 1992

TAPE/ RECORD #	DATE/TIME	PROBE LOCATION	FIGURE LOCATION	RECORD LENGTH MIN:SEC	LOCATION AND TYPE OF MEASUREMENT
	MAY 19				
1/1	8:24:37 - 8:31:11	3-1	9	6:34	PASSENGER SEAT NEAR CENTER OF CAR #1173, INBOUND ON RED LINE
1/2	8:34:40- 8:40:52	3-1	10,11	6:12	REAR SEAT OPPOSITE ENGINEER'S COMPARTMENT AND ENGINEER'S SEAT OF CAR #1173 INBOUND ON RED LINE
1/3	8:48:21 - 8:56:50	--	--	8:29	PASSENGER SEAT RIGHT HAND SIDE NEAR FRONT DOOR OF 3000 SERIES CAR, OUTBOUND ON RED LINE
1/4	9:54:31 - 10:10:42	3-1	9	16:11	PASSENGER SEAT NEAR CENTER OF CAR #3012, INBOUND ON RED LINE
1/5	10:12:21 - 10:22:22	3-1	11	10:01	ENGINEER'S SEAT IN REAR OF CAR #3012, INBOUND ON RED LINE
1/6	10:51:49 - 10:56:57	6-1	17	5:09	NORTH END OF GROSVENOR STATION AT SAFETY LINE NEAR NORTHBOUND TRACKS
1/7	10:58:44 - 11:02:52	6-1	19	4:08	NORTH END OF GROSVENOR STATION AT SAFETY LINE NEAR SOUTHBOUND TRACKS
	MAY 19				
1/8	11:19:32 - 11:25:19	6-1	25	5:47	CENTER OF GROSVENOR STATION AT SAFETY LINE NEAR NORTHBOUND TRACKS
1/9	11:26:56 - 11:30:46	6-1	27	3:50	CENTER OF GROSVENOR STATION AT SAFETY LINE NEAR SOUTHBOUND TRACKS

TABLE 2-2 (CONTINUED)

TAPE/ RECORD #	DATE/TIME	PROBE LOCATION	FIGURE LOCATION	RECORD LENGTH MIN:SEC	LOCATION AND TYPE OF MEASUREMENT
1/10	15:31:11 - 15:35:14	3-1	11	4:03	ENGINEER'S SEAT NEAR CENTER OF A 2000 SERIES CAR NORTHBOUND ON THE GREEN LINE
1/11	15:37:34 - 15:43:39	3-1	9	6:05	PASSENGER SEAT NEAR CENTER OF A 2000 SERIES CAR SOUTHBOUND ON THE GREEN LINE
1/12	15:46:48 - 15:51:28	6-2	29	4:40	SOUTH END OF GALLERY PLACE GREEN/YELLOW LINE PLATFORM AT SAFETY LINE NEAR THE SOUTHBOUND TRACKS
1/13	15:51:51 - 15:57:49	6-2	32	5:58	SOUTH END OF GALLERY PLACE GREEN/YELLOW LINE PLATFORM AT SAFETY LINE NEAR NORTHBOUND TRACKS
1/14	15:59:14 - 16:01:14	6-2	32	2:00	SAME AS 1/12
1/14A	16:04:24 - 16:05:28	6-2	34	1:04	MEZZANINE OF GALLERY PLACE ABOVE SOUTHBOUND GREEN/YELLOW LINE TRACK SOUTH
1/15	16:07:07 - 16:09:52	6-1	35	2:45	MEZZANINE OF GALLERY PLACE ABOVE SOUTHBOUND GREEN/YELLOW LINE TRACK
1/16	16:11:09 - 16:21:48	6/1	35	1:39	SAME AS 1/15
	MAY 20				
1/17	8:39:48 - 8:56:19	7-1	37,39,41	16:31	15 FEET OUTSIDE A TRACTION POWER SUPPLY STATION 2.5 MI SOUTH OF SHADY GROVE

TABLE 2-2 (CONTINUED)

TAPE/ RECORD #	DATE/TIME	PROBE LOCATION	FIGURE LOCATION	RECORD LENGTH MIN:SEC	LOCATION AND TYPE OF MEASUREMENT
1/18	8:58:33 - 9:02:35	7-1	43	4:02	SAME AS 1/17
1/19	9:05:17 - 9:08:55	7-1	45	3:38	SAME AS 1/17
1/20	9:41:40 - 9:44:38	7-2	47	2:59	15 FT OUTSIDE TRANSFORMER YARD FENCE AT THE SHADY GROVE TRACTION POWER SUPPLY STATION
2/1	9:54:34 - 9:57:16	7-2	49	2:42	15 FT OUTSIDE THE SHADY GROVE TRACTION POWER SUPPLY STATION
2/2	10:03:00 - 10:05:20	7-2	51	2:20	SAME AS 2/1
2/3	11:12:25 - 11:17:00	8-1	55	4:35	10 CM ABOVE TABLE BEHIND DISPATCHER'S CHAIR AT THE SHADY GROVE STATION
2/4	14:07:22 - 14:33:09	5-1	13	25:48	10 CM ABOVE GROUND UNDER METRORAIL BRIDGE NORTH OF ROCKVILLE STATION ON THE RED LINE

3.0 ONBOARD CAR MEASUREMENTS

When developing the measurement plan for these tests, it was apparent that magnetic fields within the car could arise from various sources:

- Track/third rail power circuit;
- Traction motors on the trucks;
- Traction power control equipment (switches, resistors, choppers, and reactors) and the associated wiring beneath the cars;
- Heating, lighting, air conditioning and other equipment on or beneath the cars; and
- External sources, such as other trains and nearby transmission lines.

Consideration was also given to the fact that three types of cars are in service on the line. In order to best evaluate the significance of the above-mentioned sources, variabilities and power supply arrangements, field measurements were made at two general locations inside each of the three types of cars: at the center of the car above traction power control equipment; and near the rear of the car above the truck mounted traction motors, third-rail contact shoes and associated wiring. At both locations in each of the three series of cars, measurements were made with the sensor staff oriented vertically so that the measurements obtained by the four sensors distributed along the staff characterized the spatial variation in magnetic field conditions in a vertical direction. This type of measurement is referred to as a vertical profile measurement. In most cases, magnetic field measurements were also made with the probe in a horizontal position, either aligned with the long axis of the car (longitudinal) or perpendicular to the long axis of the car (lateral), to quantify the spatial variability of the field in the horizontal plane. These horizontal profiles were usually measured at a height of 1 meter above the floor but were occasionally made at other heights to avoid obstructions or gain additional information. Measurements were also made in the engineer's compartment of each series of car, and they are described in Section 4.

3.1 Measurement Locations

The general layout of a WMATA Metrorail car is shown in Figure 3-1. The numbered measurement locations are keyed to datasets in Tables 2-1, 2-2, and 3-1 and to the data in the corresponding appendices. Measurements are seen to be clustered in three major locations:

- 1) Center of car - This is above the traction power control equipment which is installed beneath the car floor between the two trucks. For the 3000 series cars, this is directly above the line smoothing filter reactor mentioned as a magnetic field source in Section 2.3

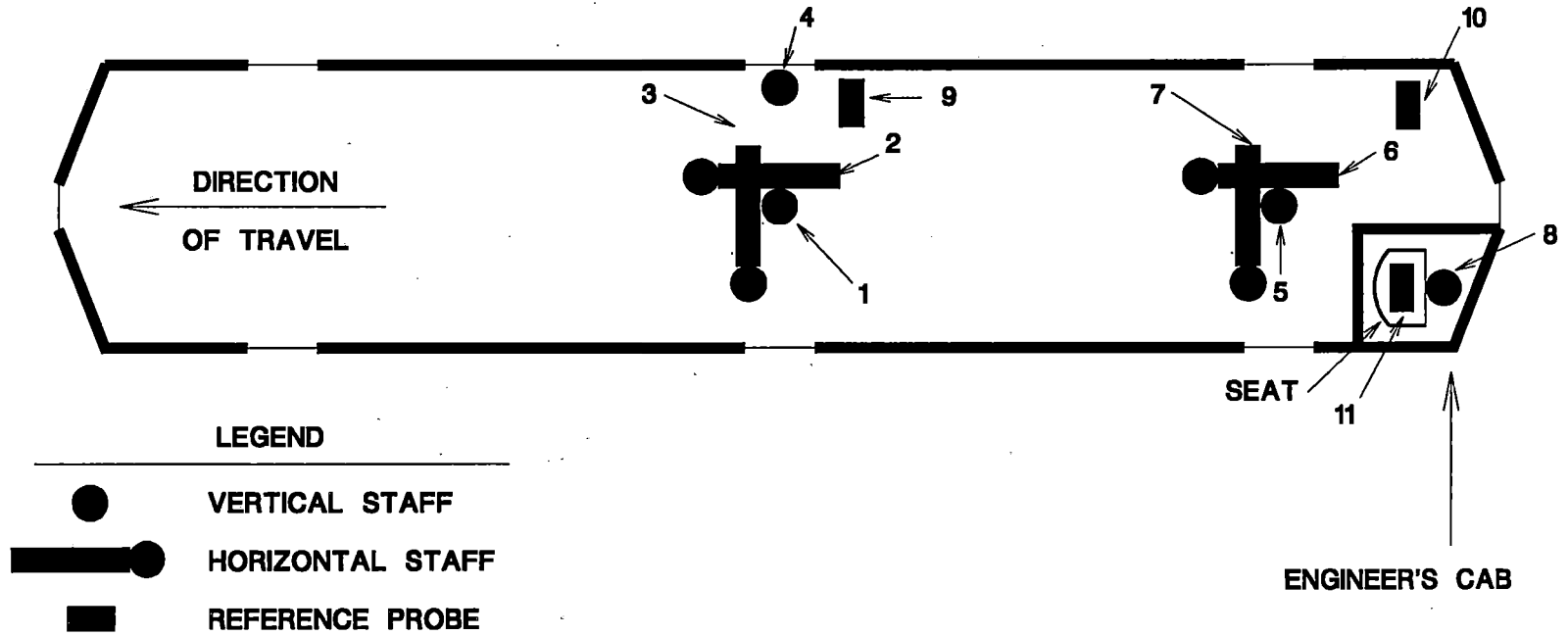

CAR LAYOUT

Figure 3-1 Repetitive waveform measurement locations within the cars and engineer's compartment.

- above. Measurements were made between the center doors at the center of the aisle.
- 2) End of car, between the rear doors - This point is above the traction motors and other truck-mounted equipment and is easily identifiable from car to car.
 - 3) Engineer's compartment - These measurements are described in Section 4.

Whenever possible, measurements were made at the same locations for all three types of cars. Onboard measurements were taken during both days of the tests (May 19 and 20, 1992). Most were on the portion of the Red Line between the Shady Grove and Van Ness-UDC stations. However, measurements on the 2000 series car had to be made on the Green Line between the Gallery Place and U Street-Cardozo stations because there were no cars of that type operating on the Red Line. All Metrorail cars were in normal revenue service during the tests.

Measurements were made mostly in the rear car of the train set where the passenger load was lighter and the engineer's compartment was unoccupied. This allowed the measurement team to move between measurement locations with the greatest likelihood of finding the locations unoccupied by revenue passengers. As illustrated in Figure 3-1, measurements were made in the middle of the car (Locations 1 through 4), at the end of the car between the doors (Locations 5, 6 and 7) and in the engineer's compartment (Location 8), for all three types of cars. Measurements were made in three different positions: vertical (Locations 1, 4, 5 and 8), horizontal-axial or parallel to the tracks (Locations 2 and 6), and horizontal-transverse, or perpendicular to the cars (Locations 3 and 7).

3.2 Repetitive Waveform Datasets

There are twenty four repetitive waveform datasets quantifying magnetic field characteristics within the Metro cars, as recorded with the *MultiWave*™ System. Table 3-1 is a summary of these datasets classified by location, position and type of car. All of these datasets represent profile measurements, either vertical or horizontal, at distances of 10, 60, 110, and 160 cm along the staff. When the staff is used in a vertical position, these dimensions represent measurement height from the floor. Figure 3-1 shows the direction of the staff when used in a horizontal orientation.

As can be seen in Table 3-1, datasets MET001, 002 and 003 are associated with Series 1000 cars. Similarly, datasets MET026 through MET030 are associated with Series 2000 cars, etc. Table 3-1 also shows the location and position orientation of the staff that is associated with each dataset. For example, dataset MET001

TABLE 3-1

REPETITIVE MAGNETIC FIELD WAVEFORM
 DATASETS MEASURED ONBOARD METRO CARS
 CLASSIFIED BY TYPE AND STAFF LOCATION

LOCATION/ POSITION	POS. #	SERIES 1000	SERIES 2000	SERIES 3000
CENTER OF CAR VERTICAL	1	MET001	MET028	MET004, MET006, MET007, MET049
CENTER OF CAR HORIZONTAL -AXIAL	2		MET029	MET013, MET050, MET053
CENTER OF CAR HORIZONTAL -TRANSVERSE	3		MET030	MET012, MET051, MET052
CENTER OF CAR AT SIDE DOOR VERTICAL	4			MET014
REAR OF CAR VERTICAL	5	MET002	MET027	MET008
REAR OF CAR BETWEEN DOORS HORIZONTAL -AXIAL	6			MET010
REAR OF CAR HORIZONTAL -TRANSVERSE	7			MET011
REAR OF CAR ENGINEER'S SEAT VERTICAL	8	MET003	MET026	MET009

was recorded with the staff in a vertical position in the center of the car and the middle of the aisle, whereas dataset MET010 was recorded with the staff in a horizontal position, in the direction of travel, at the rear of the car, and dataset MET009 was recorded with the staff in a vertical position up against the front of the engineer's seat. The horizontal profiles were measured at a height of approximately 1 m above the floor.

Complete plots of field versus frequency over time, and field versus distance over time are found in the appendices as indicated in Table 2-1. The appendices also contain notes about train operating conditions, locations and, where pertinent, the presence of external field sources such as power lines or substations.

3.3 Magnetic Field Characteristics

Magnetic field measurements onboard the coaches provided the opportunity to measure the extent to which various operating conditions contribute to the total magnetic field environment. That information, together with other temporal, frequency and spatial characteristics of the magnetic field, offers insight to the probable sources of the magnetic field within the passenger compartment of the Metrorail cars.

The top frame of Figure 3-2 shows a plot of magnetic field strength near the floor in the center of a 1000 series car as a function of frequency and time. Two significant characteristics of the magnetic field are immediately obvious. First, the magnitude of the field is highly variable over the time of the recording. This measurement started shortly after the car left the Shady Grove station and ended after the car stopped at the Twinbrook station. There was an intermediate stop at the Rockville station at about 120 seconds into the record. It appears from the temporal characteristics of Figure 3-2 that the static (zero frequency) magnetic field at the measurement location is elevated well above the normal geomagnetic field level of 500 mG when the train is accelerating out of a station or decelerating as it approaches a station. However, when the train is stopped at a station (as at the 120 second point) or coasting prior to braking in order to decelerate into a station (as at the 40 second and the 175 second points), the static magnetic field at the measurement point is principally the naturally occurring geomagnetic field of the earth. The temporal correlation between field level and vehicle acceleration or deceleration indicates that the source of the field involves the propulsion system. Current in the third-rail and track circuit is not a likely source because the elevated field exists during both acceleration and deceleration. Since the 1000 series cars do not have regenerative braking, there is no increase in third-rail current during deceleration, but since these cars have dynamic braking, there is elevated current in the resistors, contactor switches, and other components and associated wiring of the traction power control circuitry beneath the floor of the car

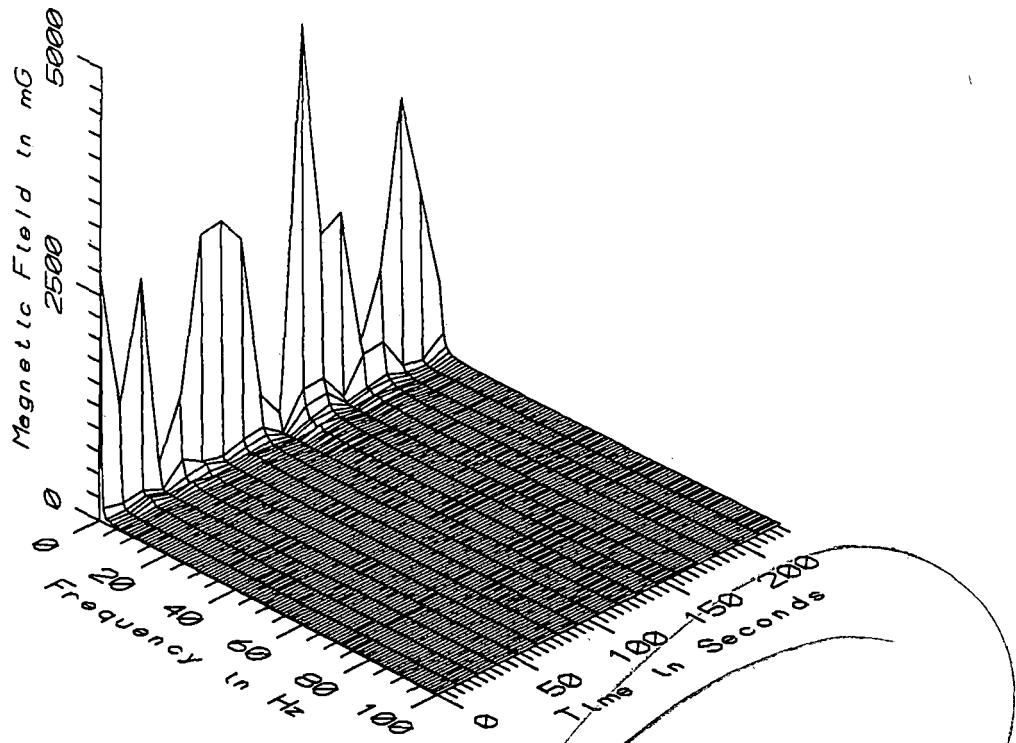

MET001 - 10cm ABOVE FLOOR, CENTER OF AISLE, CENTER OF CAR 1173

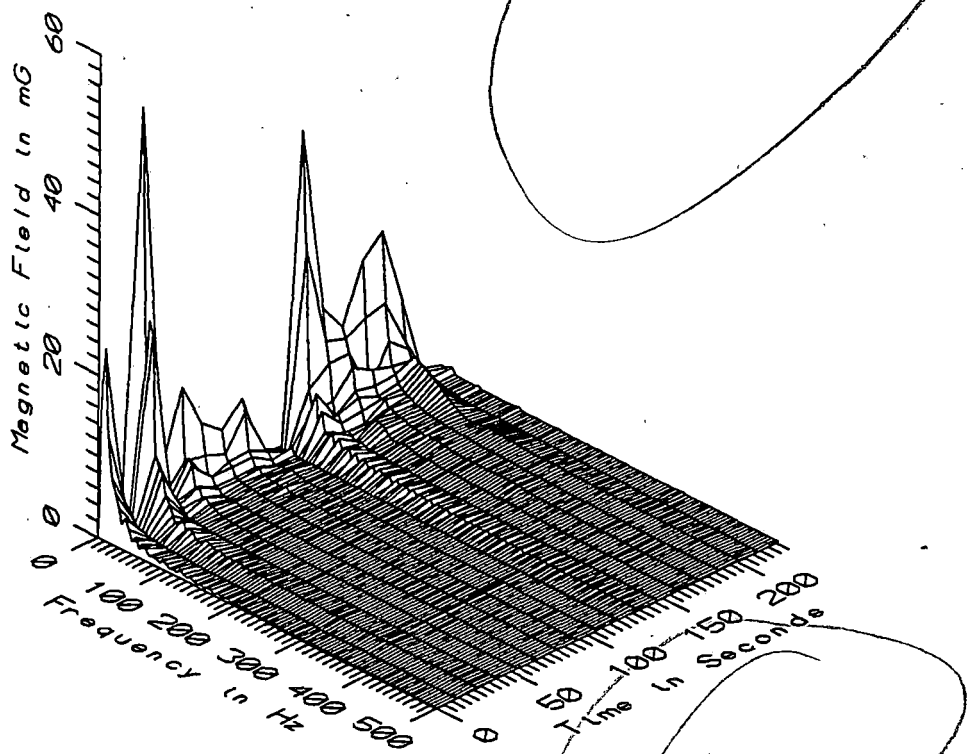

MET001 - 10cm ABOVE FLOOR, CENTER OF AISLE, CENTER OF CAR 1173

Figure 3-2 Magnetic field 10 cm above the floor in the center of a 1000 series car as a function of frequency and time. The static field component is suppressed in the lower frame to show the time varying components.

during both acceleration and braking. Therefore, that system appears to be a likely field source based on the temporal characteristics of the magnetic field near the floor in the center of the 1000 series car.

The second important characteristic of the magnetic field in the center of the 1000 series car as depicted in Figure 3-2 is that the only time varying components of the magnetic field are those related to changes in the static field level. This point is most clearly illustrated by the bottom frame of the figure, in which the static component of the magnetic field has been removed and the time varying components are replotted on a more appropriate scale of magnetic field intensity. The pattern of field intensity decreasing exponentially with increasing frequency seen in these data is indicative of shifts in static field level which have no stable periodic frequency. This absence of discrete-frequency time varying components in the magnetic field frequency spectrum is consistent with the suggestion that, from the characteristics of the field, the primary source is the traction power control equipment installed beneath the floor of the car.

Figure 3-3 is similar to Figure 3-2 except that it shows the magnetic field levels measured 160 cm above the floor at the center of the 1000 series car. Since the data in these two figures were measured simultaneously, they can be compared point-by-point. Although the temporal characteristics of the static fields are similar at both measurement locations, the intensity levels are quite different. The magnitude of the static field during periods of train acceleration and deceleration are much smaller at the point 160 cm above the floor (Figure 3-3) than at the point much nearer the floor (Figure 3-2), but during periods when the train is stopped or coasting, the field levels are comparable. Similar data for intermediate measurement heights above the floor, provided in Appendix B, fall in between the extremes illustrated here. By comparing the static magnetic field levels measured at the four heights above the floor for each time point throughout the measurement record, the vertical profile of field attenuation over time shown in the top frame of Figure 3-4 is obtained. The orderly attenuation of magnetic field level with increasing height above the floor during periods of train acceleration and deceleration further supports the other indications that the principal static field source in the 1000 series car at this location is the traction power control system beneath the floor. When the train is coasting or stopped, such as at the 120 second point, the static magnetic field no longer shows attenuation with increasing height above the floor, but a relatively constant field strength at all heights. Of course, that is the situation one would expect if the principal static field source at those times is the natural geomagnetic field.

The time varying magnetic fields at the measurement point 160 cm above the floor (lower frame of Figure 3-3) show the same

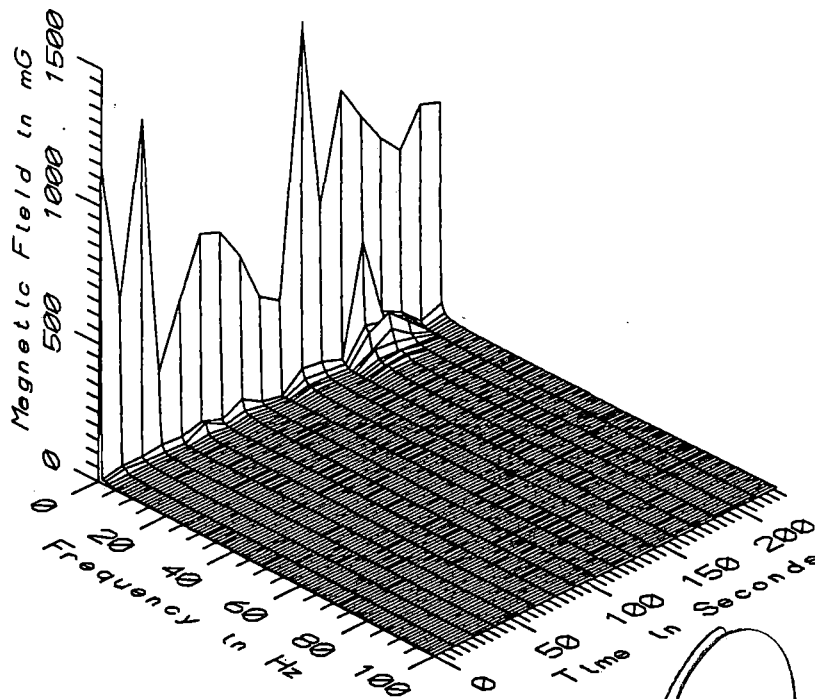

MET001 - 160cm ABOVE FLOOR, CENTER OF AISLE, CENTER OF CAR 1173

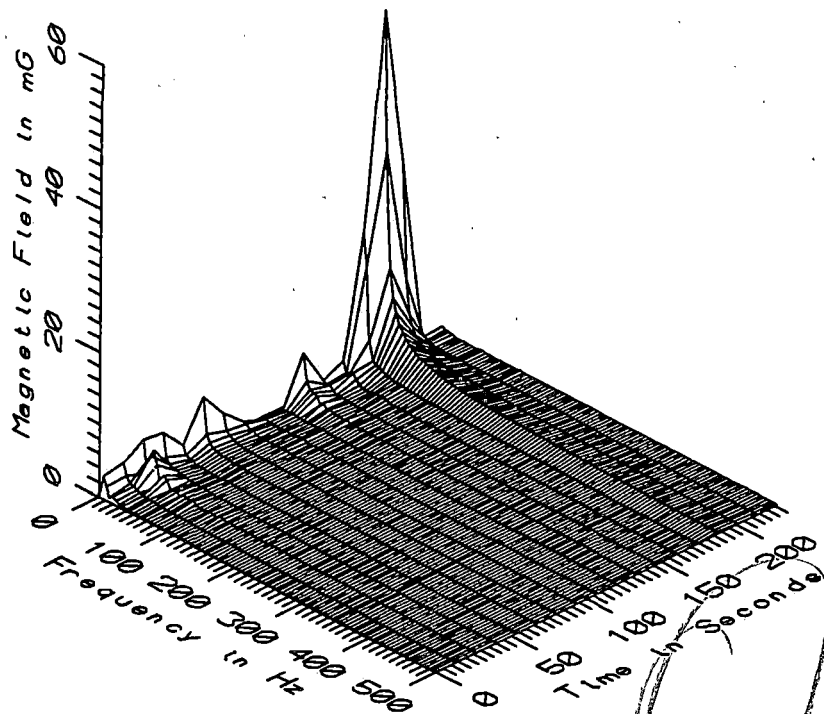

MET001 - 160cm ABOVE FLOOR, CENTER OF AISLE, CENTER OF CAR 1173

Figure 3-3 Magnetic field 160 cm above the floor in the center of a 1000 series car as a function of frequency and time. The static field component is suppressed in the lower frame to show the time varying components.

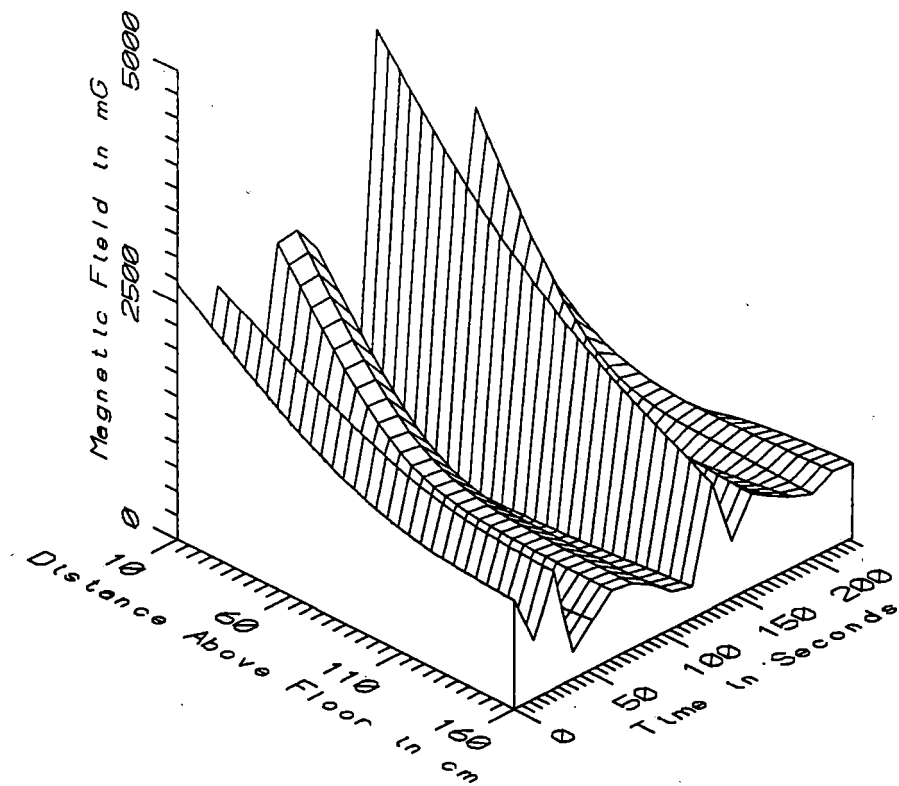

MET001 - CENTER OF AISLE, CENTER OF CAR 1173 - STATIC

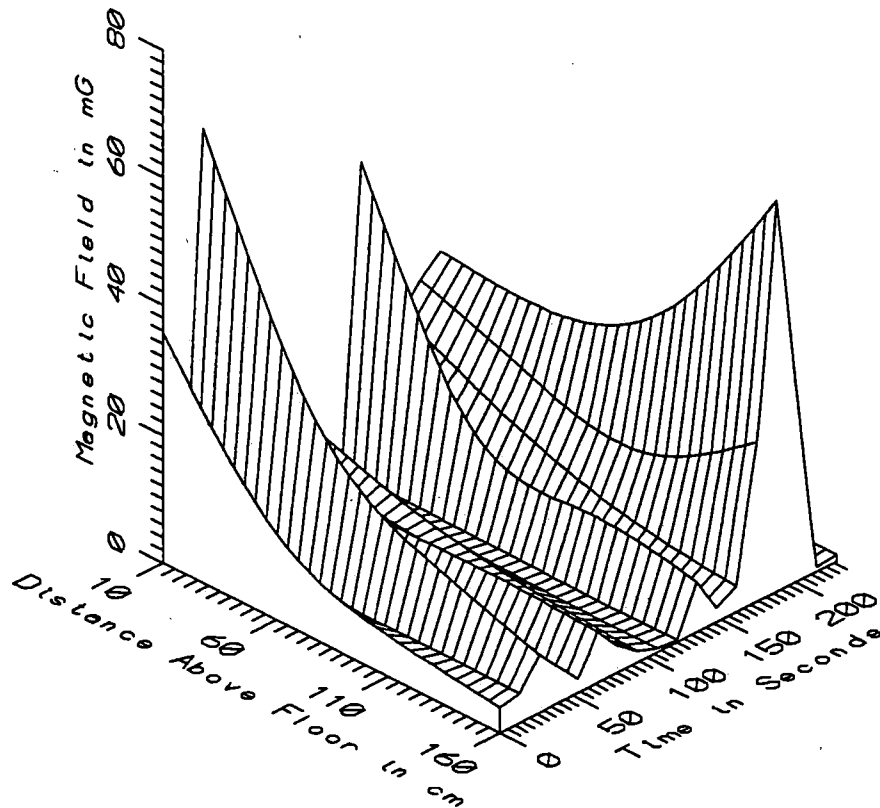

MET001 - CENTER OF AISLE, CENTER OF CAR 1173 - LOW FREQ, 5-45Hz

Figure 3-4 Static (top frame) and low frequency time varying (bottom frame) magnetic field in the center of a 1000 series car as a function of height above the floor and time.

exponential decay with increasing frequency seen at the lower measurement point but, at most time points, the fields are smaller at the higher location. There is one clear contradiction to that trend at the 185 second point in the data record, where the time varying field is larger at the higher measurement location. Those attenuation features are shown more graphically in the lower frame of Figure 3-4, where the magnitude of the low frequency components of the time varying magnetic fields at the four measurement heights are plotted to produce vertical attenuation profiles over the time period of the record. These data suggest the presence of an overhead source of small but rapidly changing non-periodic magnetic field. The only electromagnetic device known to be above the measurement staff at the center of the car is the public address loudspeaker.

Dataset MET002 consists of magnetic field data similar to those just discussed from dataset MET001 except that they were measured in the rear of the same 1000 series car, in the middle of the aisle at the centerline of the rear doors. The complete data are provided in Appendix C, but graphs of the magnetic field as a function of frequency and time at the low sensor location (10 cm above the floor) and the high sensor location (160 cm above the floor) are included here as Figures 3-5 and 3-6, respectively. Visual comparison of those graphs to the corresponding graphs of data measured at the center of the car (Figures 3-2 and 3-3) shows that the magnetic fields at the rear of the car are similar in character to those at the center of the car except that they are lower in intensity. Figure 3-7 shows the vertical attenuation profiles of the static and low frequency time varying magnetic field levels at the rear of the car. The static component shows a clear attenuation with height above the floor, confirming that the principal source (other than the uniform geomagnetic field) is again below the floor. The time varying magnetic field in general shows less attenuation with height at the rear of the car than either the static field at that location or the time varying magnetic field at the center of the car. This would suggest that the time varying magnetic field at the rear of the car originates from a source different from the under-floor source producing the elevated static field at the rear of the car and that the source of the time varying field is not directly beneath the measurement point. The time varying magnetic fields at the rear of the 1000 series car also show evidence of an overhead magnetic field source in at least one time sample (75 seconds). Perhaps coincidentally, this measurement was also made directly beneath a public address loudspeaker.

The magnetic field levels at the center of the 1000 series car contained in dataset MET001 cannot be compared to magnetic field levels at the rear of the same car (dataset MET002) on a point-by-point basis because they were not measured simultaneously. Instead, they must be compared statistically. Figure 3-8 provides a graphical comparison of the static magnetic field levels 110 cm

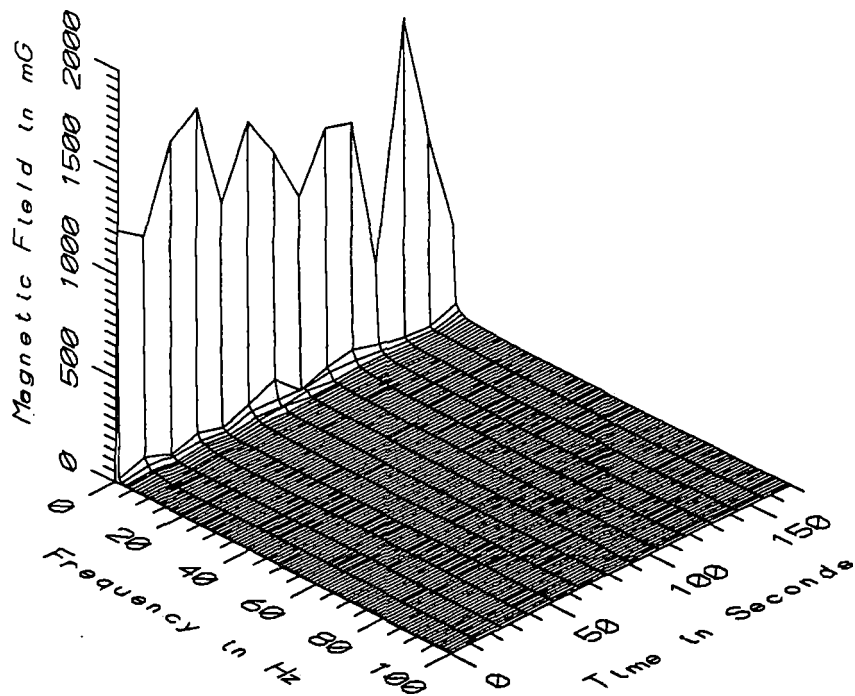

MET002 - 10cm ABOVE FLOOR, CENTER OF AISLE, REAR OF CAR 1173

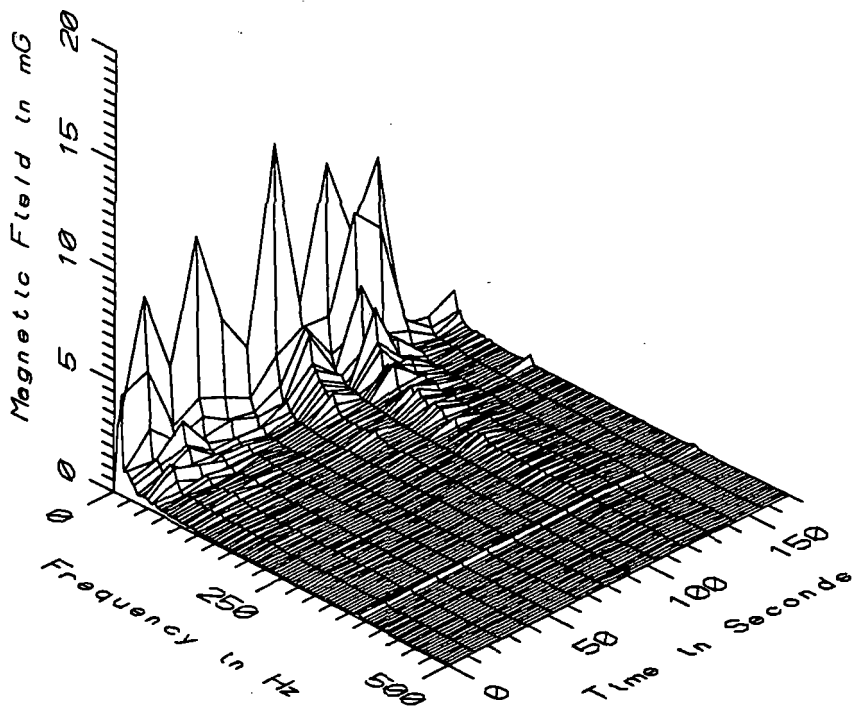

MET002 - 10cm ABOVE FLOOR, CENTER OF AISLE, REAR OF CAR 1173

Figure 3-5 Magnetic field 10 cm above the floor in the rear of a 1000 series car as a function of frequency and time. The static field component is suppressed in the lower frame to show the time varying components.

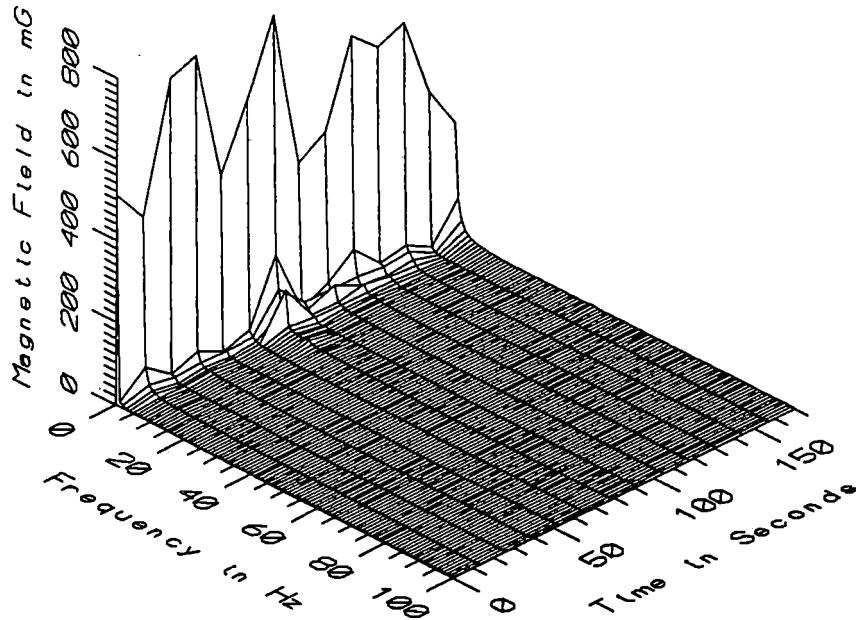

MET002 - 160cm ABOVE FLOOR, CENTER OF AISLE, REAR OF CAR 1173

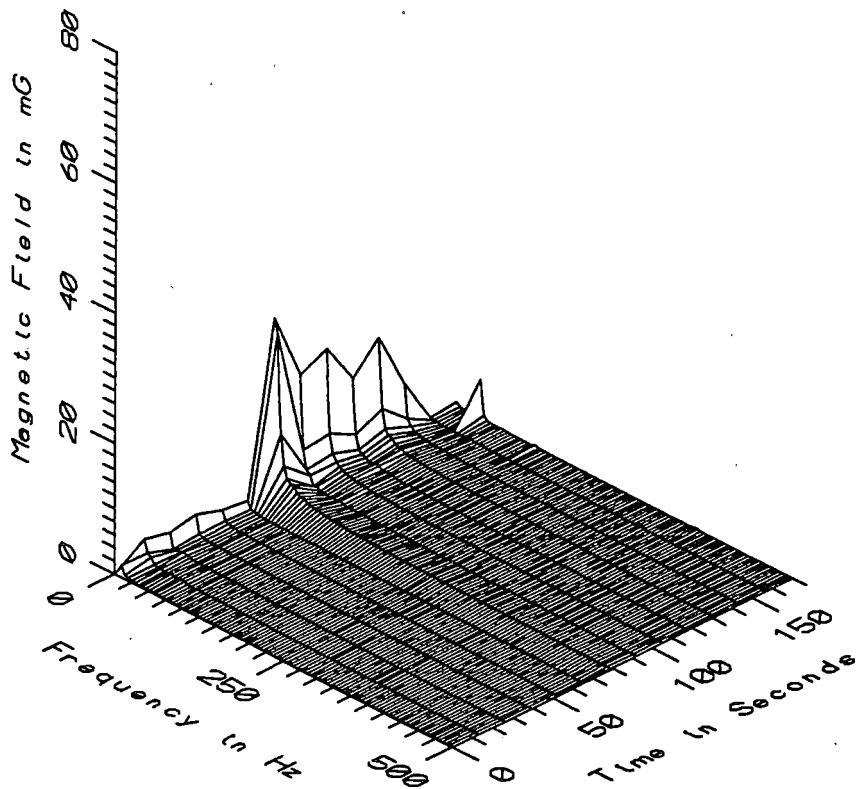

MET002 - 160cm ABOVE FLOOR, CENTER OF AISLE, REAR OF CAR 1173

Figure 3-6 Magnetic field 160 cm above the floor in the rear of a 1000 series car as a function of frequency and time. The static field component is suppressed in the lower frame to show the time varying components.

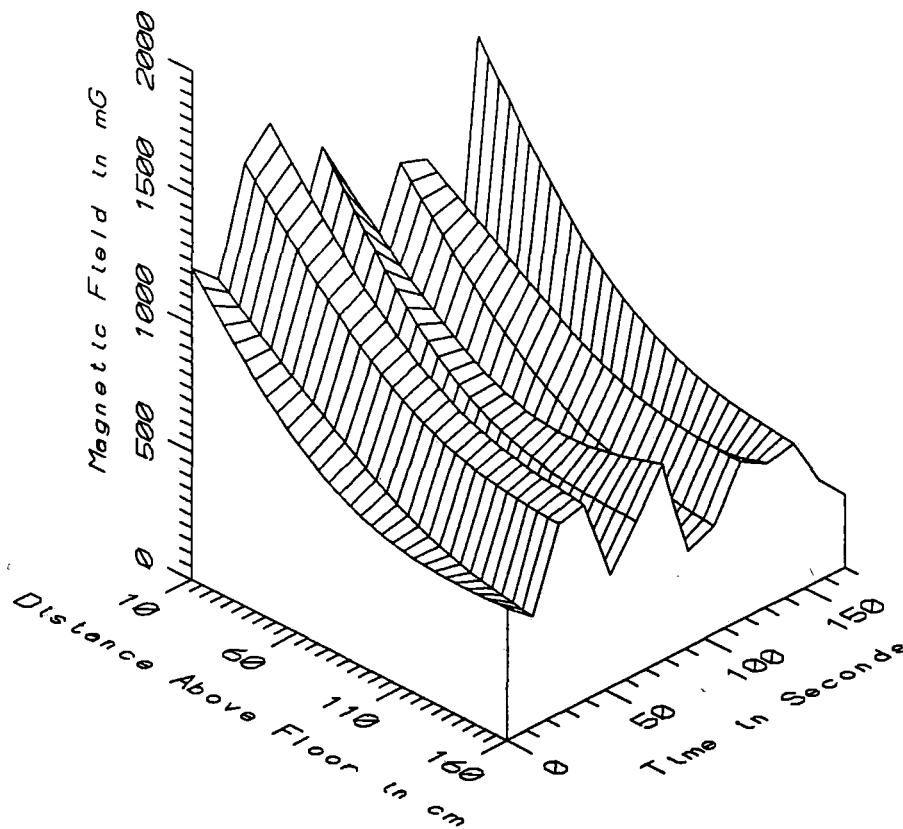

MET002 - CENTER OF AISLE, REAR OF CAR 1173 - STATIC

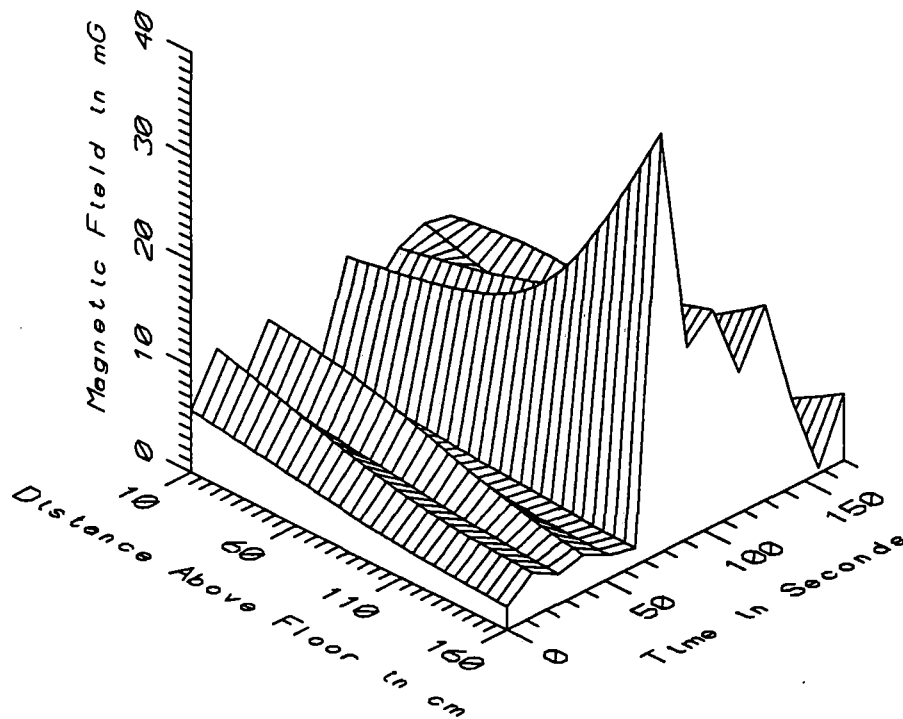

MET002 - CENTER OF AISLE, REAR OF CAR 1173 - LOW FREQ, 5-45Hz

Figure 3-7 Static (top frame) and low frequency time varying (bottom frame) magnetic field in the rear of a 1000 series car as a function of height above the floor and time.

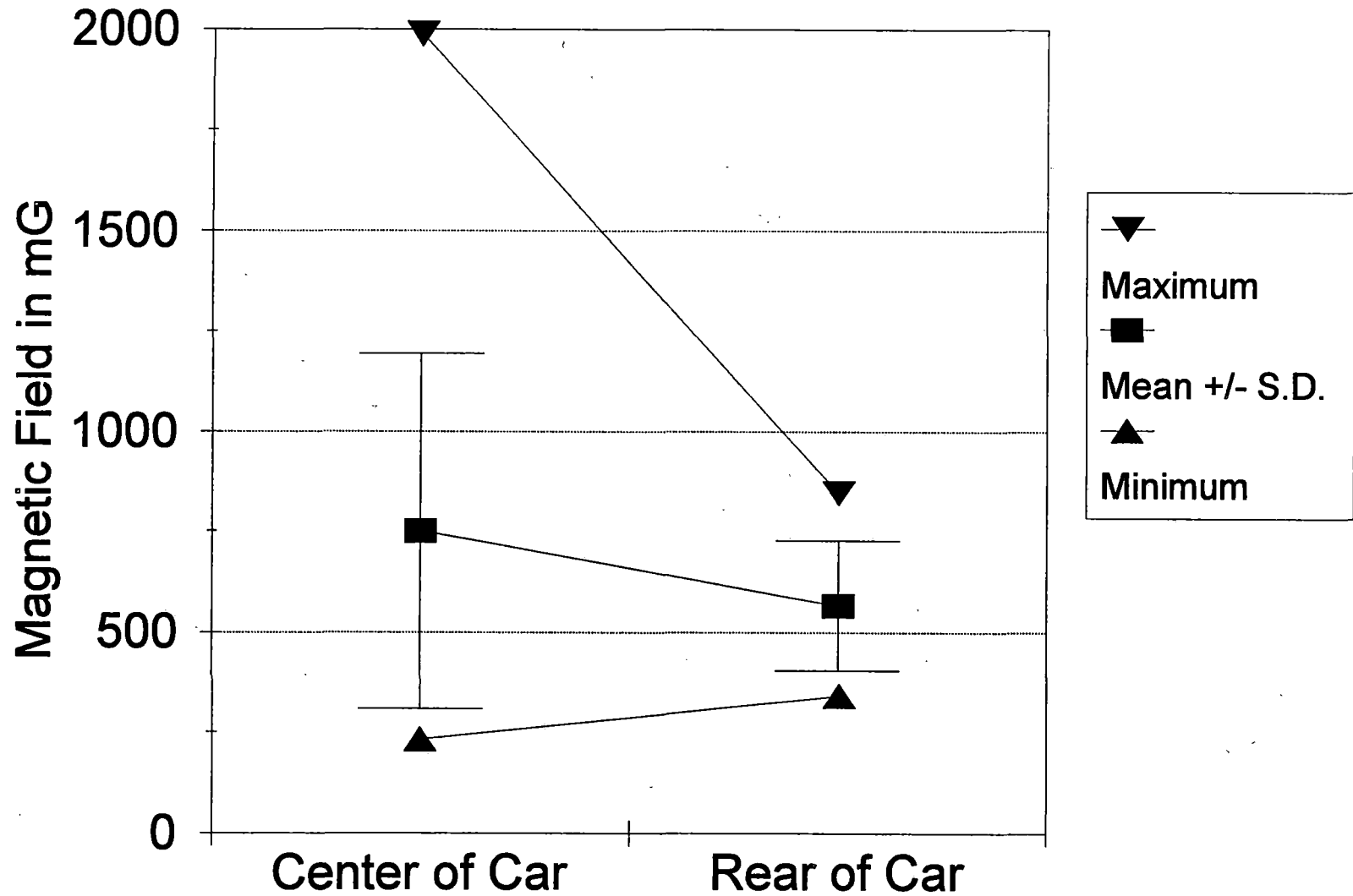
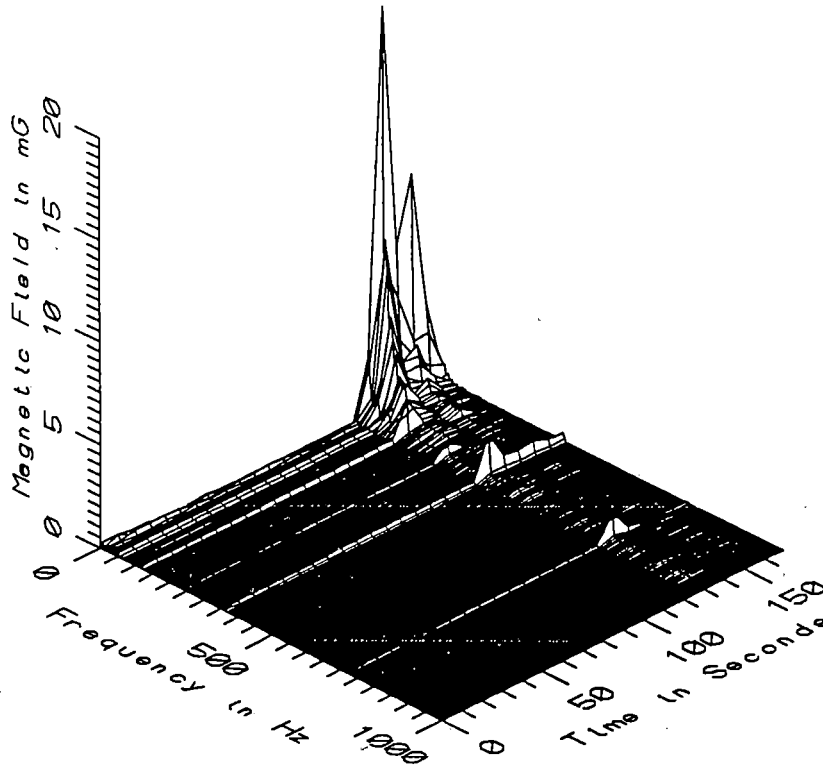

Figure 3-8 Graphical comparison of static magnetic field levels 100 cm above the floor at the center of a 1000 series car based on statistical descriptors.

above the floor at those two locations based on maximum, minimum and average field levels. Additional statistical comparisons of field levels are provided below in Section 3.6. Statistical summaries of most of the datasets are also contained in the appendices to permit the reader to make whatever comparisons are required.

As indicated in Table 3-1, measurements similar to those reported for the 1000 series car were conducted on a 2000 series car operating on the Green Line. The results of the measurements in the passenger compartment of the 2000 series cars are contained in Appendices X through AA in Volume II of this report. The magnetic fields found in the 2000 series cars were similar in intensity, temporal variability, and spatial variability to the fields in the 1000 series cars described above. The frequency characteristics of the magnetic field are also similar with the exception that in the 2000 series cars, periodic magnetic fields with discrete frequencies (even harmonics of the 60 Hz power frequency) are present in the magnetic field frequency spectrum. Figure 3-9 shows the magnetic field as a function of frequency and time with the static field suppressed at two heights above the floor in the center of a 2000 series car. The car was stationary at the U Street-Cardozo station for the first 120 seconds of the record. Of these fixed-frequency field components, the second (120 Hz), sixth (360 Hz) and twelfth (720 Hz) harmonics of 60 Hz are the most apparent and are typical of rectifier ripple on dc power systems derived from rectification of 60 Hz ac power. Although those components of the magnetic field are present at low amplitudes when the train is stationary, their magnitudes increase substantially when the train begins to accelerate at the 130 second time point. The 360 Hz component remains elevated to the end of the record as the train continues to draw power from the dc third rail. The magnitudes of the ripple components decrease with increasing height above the floor, indicating that the source of these fields is below the floor of the car. All indications suggest that these time varying field components come from an ac ripple component on the dc current in the traction power control equipment beneath the floor or ripple current in the third-rail and track return circuit, or both. From the available data, it cannot be determined with certainty whether this increased intensity of ripple frequency ac magnetic field components measured in the 2000 series relative to those in the 1000 series cars represents a difference in the under-car propulsion systems or differences in the extent of dc power filtering in traction power supply stations on the two lines. Magnetic field measurements at station platforms on the Red and Green Lines showed similar levels of ripple current, as discussed in Section 6 of this report. That fact suggests that the differences in ripple frequency components in the magnetic fields of 1000 series cars versus 2000 series cars results from differences in the propulsion systems, or perhaps from more extensive filtering on the 1000 series cars.



MET028 - 10cm ABOVE FLOOR, CENTER OF AISLE, CENTER OF CAR 2xxx

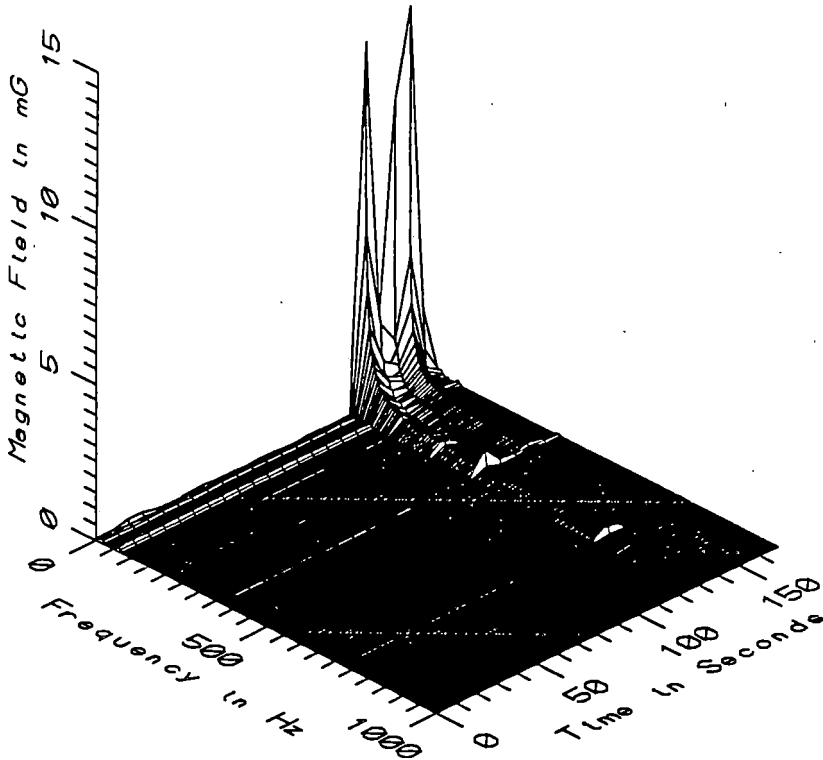

MET028 - 160cm ABOVE FLOOR, CENTER OF AISLE, CENTER OF CAR 2xxx

Figure 3-9 Time varying magnetic field 10 cm and 160 cm above the floor at the center of a 2000 series car as a function of frequency and time.

As mentioned earlier, the 3000 series cars use semiconductor choppers to control the amount of power supplied to the traction motors. Therefore, the magnetic fields produced by the traction power control system are different from those produced by CAM controlled systems such as those in the 1000 and 2000 series cars. Figures 3-10 and 3-11 show the magnetic field characteristics at two heights above the floor at the center of a 3000 series car as it departs Rockville station. Unfortunately, the total magnetic field at a measurement point 10 cm above the floor shown in Figure 3-10 exceeded the five gauss range of the fluxgate magnetometer at the 6 second sample point, thereby producing invalid data at that measurement time point. The magnetic field levels were lower at sensor locations higher above the floor, as in Figure 3-11, thereby allowing valid measurements at all time points. Alternative measurements and analysis conducted to characterize magnetic fields near the floor at this point are discussed later in this section. At this point, however, the discussion will remain focused on the characteristics of the magnetic field in the 3000 series cars.

The upper frame of Figure 3-11 showing the static and low frequency time varying magnetic fields 160 cm above the floor in the 3000 series car looks very similar in character to those discussed earlier for 1000 series cars (e.g., Figure 3-6) except that the peak fields tend to be larger. The principal characteristics of increased static fields during acceleration and low frequency time varying fields due to changes in static field levels which decrease in intensity with increasing frequency are present in both systems. Neglecting the invalid data at the six second point of the data in Figure 3-10, it can be seen that there is also strong attenuation of the static field with increasing height above the floor. The upper frame of Figure 3-12 shows the vertical attenuation profile over time for the simultaneous static field measurements at the four sensor heights at the center of the 3000 series car. As previously mentioned, the data at the 6 second point for both the 10 cm and the 60 cm sensors are invalid. The remaining points demonstrate a consistent attenuation characteristic except at time zero when the train was standing at the station. The field attenuation rate depicted here is much more rapid than that seen in the center of the 1000 and 2000 series cars.

The lower frames of Figures 3-10 and 3-11 show the time varying components of the magnetic field at the center of the 3000 series car. As before, the static component of the field has been suppressed and the data plotted over a wider frequency range. Time varying frequency components of the magnetic field at the chopper frequency (273 Hz) and harmonics thereof are clearly evident. Most of the energy is in the 273 and 546 Hz components.

The attenuation pattern of the time varying component of the magnetic field at the center of the 3000 series car is plotted in the lower frame of Figure 3-12 and, neglecting the invalid data at 10 and 60 cm above the floor at the 6 second point, shows an

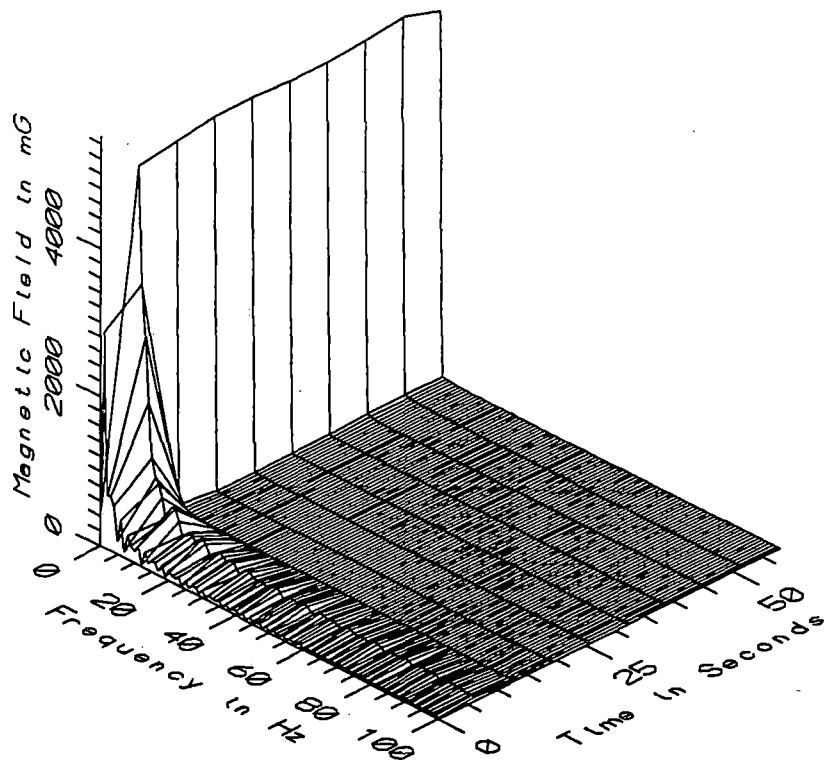

MET006 - 10cm ABOVE FLOOR, CENTER OF AISLE, CENTER OF CAR 3012

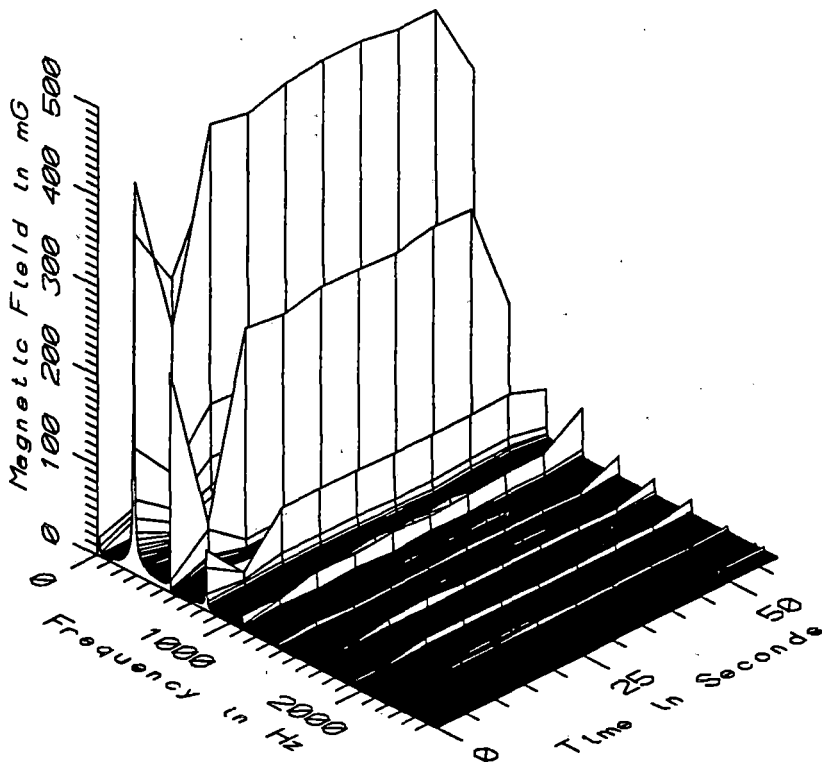

MET006 - 10cm ABOVE FLOOR, CENTER OF AISLE, CENTER OF CAR 3012

Figure 3-10 Magnetic field 10 cm above the floor in the center of a 3000 series car as a function of frequency and time. The static field component is suppressed in the lower frame to show the time varying components. Data at the 6 second data point are invalid.

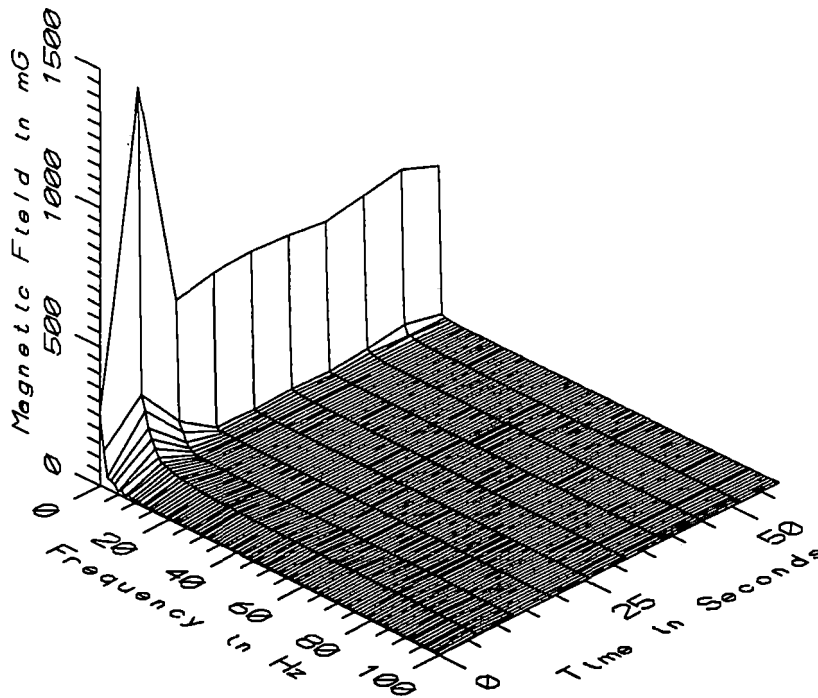

MET006 - 160cm ABOVE FLOOR, CENTER OF AISLE, CENTER OF CAR 3012

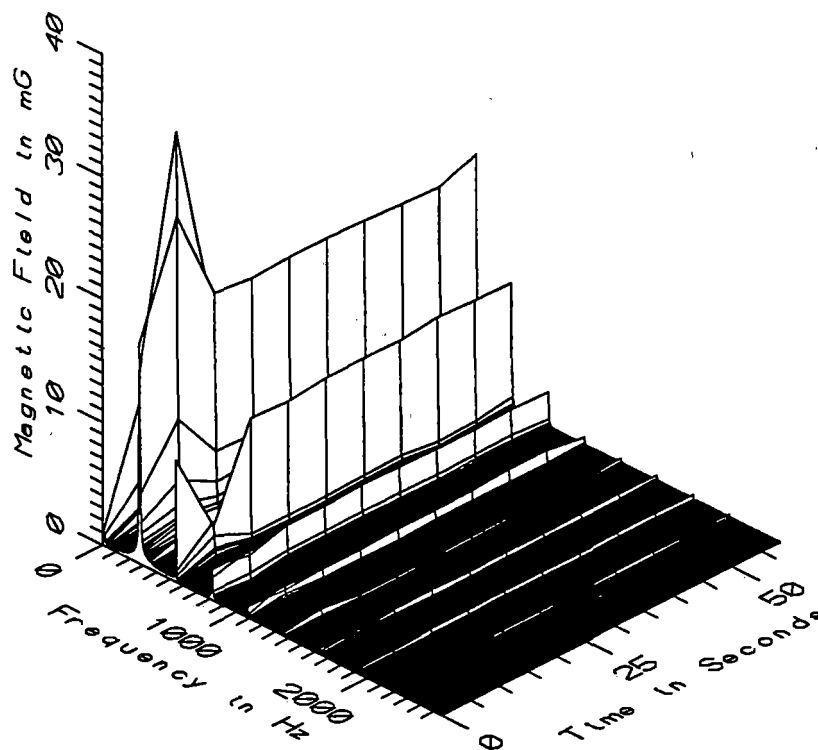

MET006 - 160cm ABOVE FLOOR, CENTER OF AISLE, CENTER OF CAR 3012

Figure 3-11 Magnetic field 160 cm above the floor in the center of a 3000 series car as a function of frequency and time. The static field component is suppressed in the lower frame to show the time varying components.

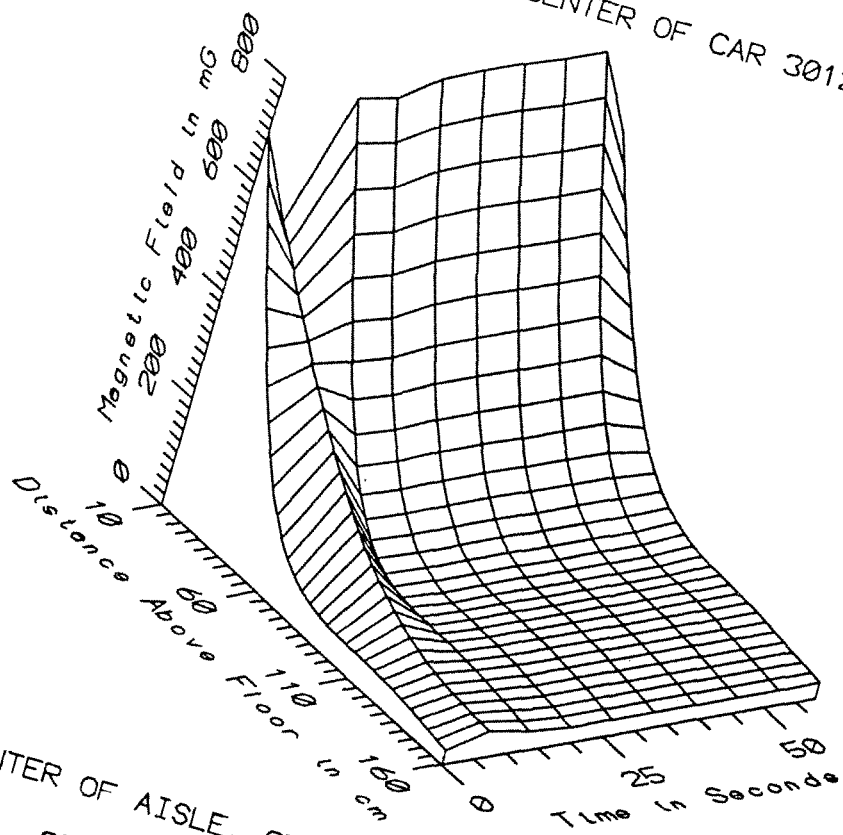
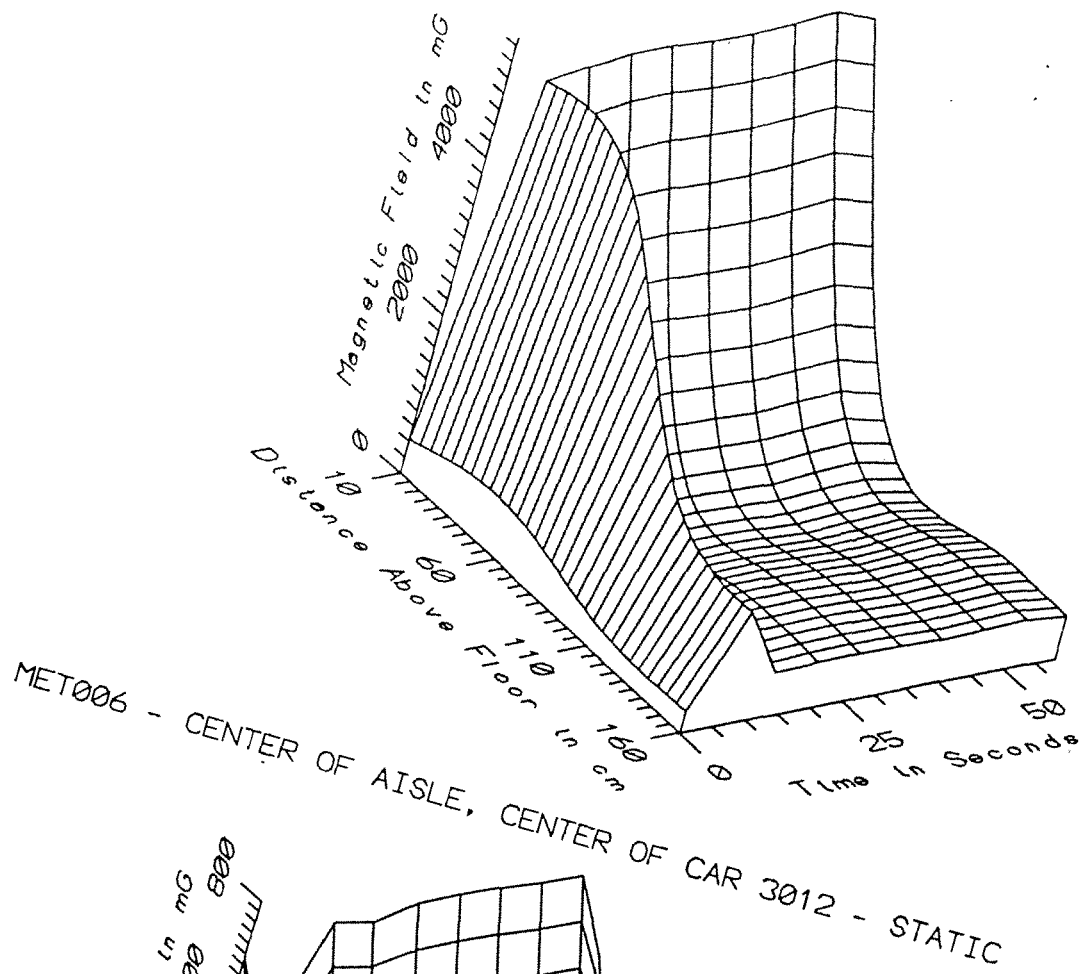

Figure 3-12

Static (top frame) time varying (bottom frame) magnetic field in the center of a 3000 series car as a function of height above the floor. Data at 10 and 60 cm above the floor are invalid at the 6 second time point.

attenuation rate identical to that of the static field shown in the frame above it. Regression analysis of the available data indicates that the attenuation pattern best fits the equation:

$$B = B_0 * (1/d^3)$$

where: B is the magnetic field;
B₀ is the magnetic field at unity distance; and
d is the distance from the source.

From the analysis, the apparent field source is centered 55 cm below the floor of the car. That is, in the above equation, the distance, d, is the height of the measurement above the floor plus 55 cm. Visual examination of the underside of a 3000 series car showed that the large line smoothing reactor beneath the car is nearly 55 cm below the top surface of the floor. By using the relationship in the above equation, data lost due to saturation of the sensor magnetometers near the floor can be estimated from valid data measured at greater heights above the floor if evidence exists that the field source is the one modeled by the above equation. For example, the static field value at 10 cm above the floor at the 6 second mark in dataset MET006 (Figure 3-10) is estimated to be 29 gauss (29,000 mG).

In order to obtain valid measurements of the time varying magnetic field without the need to extrapolate from measurements at other locations, several repeat measurements were made in the center of a 3000 series car using coil-type magnetometers which do not respond to static magnetic fields and thereby avoid the saturation problems encountered with the fluxgate sensors. Of the ten datasets identified in Table 3-1 as being measured in the center of a 3000 series car, five were measured using coil-type sensors with the *MultiWave*™ recording system. Those are datasets MET049 through MET053. There are no concurrent static field measurements in these datasets obtained with the coil-type sensors. Figure 3-13 shows a graph of time varying magnetic field levels measured 10 cm above the floor at the center of a 3000 series car using coil-type sensors. It shows the same characteristics as Figure 3-10 measured with the fluxgate magnetometers without any data lost to instrument saturation. In fact, the data from the 50 to 100 second time points of Figure 3-13 are virtually identical to the data in Figure 3-10.

Lateral (transverse horizontal) and longitudinal (axial horizontal) measurements of magnetic field at floor level (Appendices AT and AU) and at 1 meter above the floor (Appendices L, M, AV and AW) in the center of the 3000 series cars show that the predominant source for static and time varying magnetic fields in the center of the car is highly localized and most certainly the line smoothing reactor. However, the longitudinal profiles suggest that there are

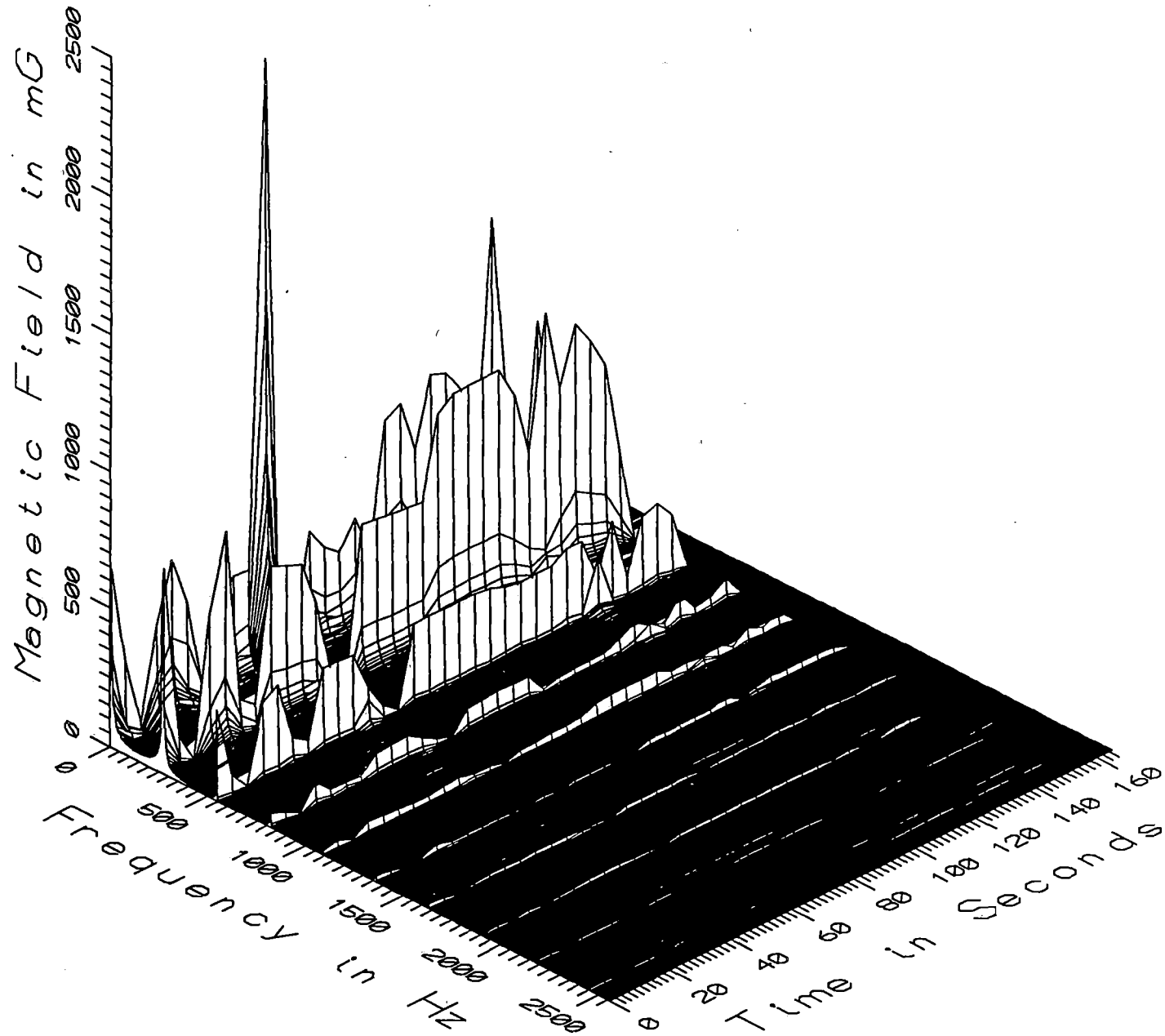

MET049 - 10cm ABOVE FLOOR, CENTER OF AISLE, CENTER OF CAR 3XXX

Figure 3-13 Time varying magnetic field 10 cm above the floor at the center of a 3000 series car measured with coil-type sensors.

other sources below the floor both in back of and in front of the reactor.

Magnetic field measurements at the rear of the 3000 series cars show magnetic field characteristics similar to those seen in the rear of the 1000 and 2000 series cars. Although time varying field components are still present at the chopper frequency and its harmonics, they are much smaller (less than 2 mG) and generally less than the time varying components of the field believed to arise from ripple on the dc power fed to the car.

3.4 DAT Waveform Data

Magnetic field data from the reference probe of the *MultiWave*™ System was recorded continuously with a DAT recorder, as described in Section 2.5. Continuous field data were measured at a window seat near the center of each of the three types of cars and on the engineer's seat in the cars. Additional measurements were made at different locations in some cars as identified in Table 2-2. Those recordings provide better detail of the temporal characteristics of the static fields than do the repetitive waveform data because there are no interruptions necessary to store the incoming data from the single sensor. Those recordings were scanned for transient fields or sudden, brief excursions in field level which were fundamentally different from those recorded by the periodic sampling of the *MultiWave*™ System. Occasional magnetic field transients found near the center of the 3000 series cars appeared to result from the traction power control system switching between operational modes. They were not observed during periods of time when the static field component was not changing and the time varying magnetic field from the chopper ripple was constant. Comparisons between the DAT static field data and the *MultiWave*™ static field data measured on the reference probe confirmed the good correlation between the two which was previously reported³. However, since the DAT recorder system does not have automatic gain control, the occasionally large time varying magnetic fields produced by changes in the large static field necessitated recording the time varying fields on a very insensitive range and much of the detail of the low-level components of the time varying magnetic fields was lost.

A statistical summary of static magnetic field levels measured by the DAT recorder system in the passenger compartments of the Metrorail cars is presented in Table 3-2.

Another valuable application of the DAT data is to characterize the time-rate-of-change of the magnetic field within the passenger section of a Metrorail car. Figures 3-14 and 3-15 show the fine time characteristics' typical changes in static field measured in the 1000 and 3000 series cars, respectively. The time-rate-of-change of the field shown in Figure 3-14 for the 1000 series car is

approximately two to four gauss per second. Typical rates of change measured in the 2000 series car were similar. Note the presence of the chopper ripple on the static field of the 3000 series car shown in Figure 3-15. The average time-rate-of-change for the magnetic field, in this case neglecting the chopper ripple, is about 1.5 G/s. This particular section of the DAT recording in the 3000 series car was selected because it also shows one of the occasional transient magnetic field episodes detected in the center of a 3000 series car. The maximum time-rate-of-change of the magnetic field at the transient was approximately 40 G/s, which is roughly comparable to the time-rate-of-change of the 273 Hz chopper ripple superimposed on the near-static field waveform.

TABLE 3-2

**SUMMARY OF STATIC MAGNETIC FIELD LEVELS RECORDED
IN A PASSENGER SEAT OF A METRORAIL CAR RECORDED WITH
THE DIGITAL AUDIO TAPE RECORDER (DAT)**

SERIES OF CAR (TAPE/REC.)	MEASUREMENT LOCATION		STATIC MAGNETIC FIELD MILLIGAUSS		
	FIGURE #	LOCATION	MINIMUM	AVERAGE	MAXIMUM
1000 CENTER (1/1)	3-2	9	198	816	1736 *
2000 CENTER (1/11)	3-2	9	95	634	2164
3000 CENTER (1/4)	3-2	9	434	1601	2936
3000 FRONT (1/3)	-	-	2	1012	2737

* Some portions of this record were saturated due to an insufficiently high range setting on the DAT. Therefore, the true maximum field is larger than indicated. The average value is not believed to be significantly affected due to the small portion of the total record where saturation occurred.

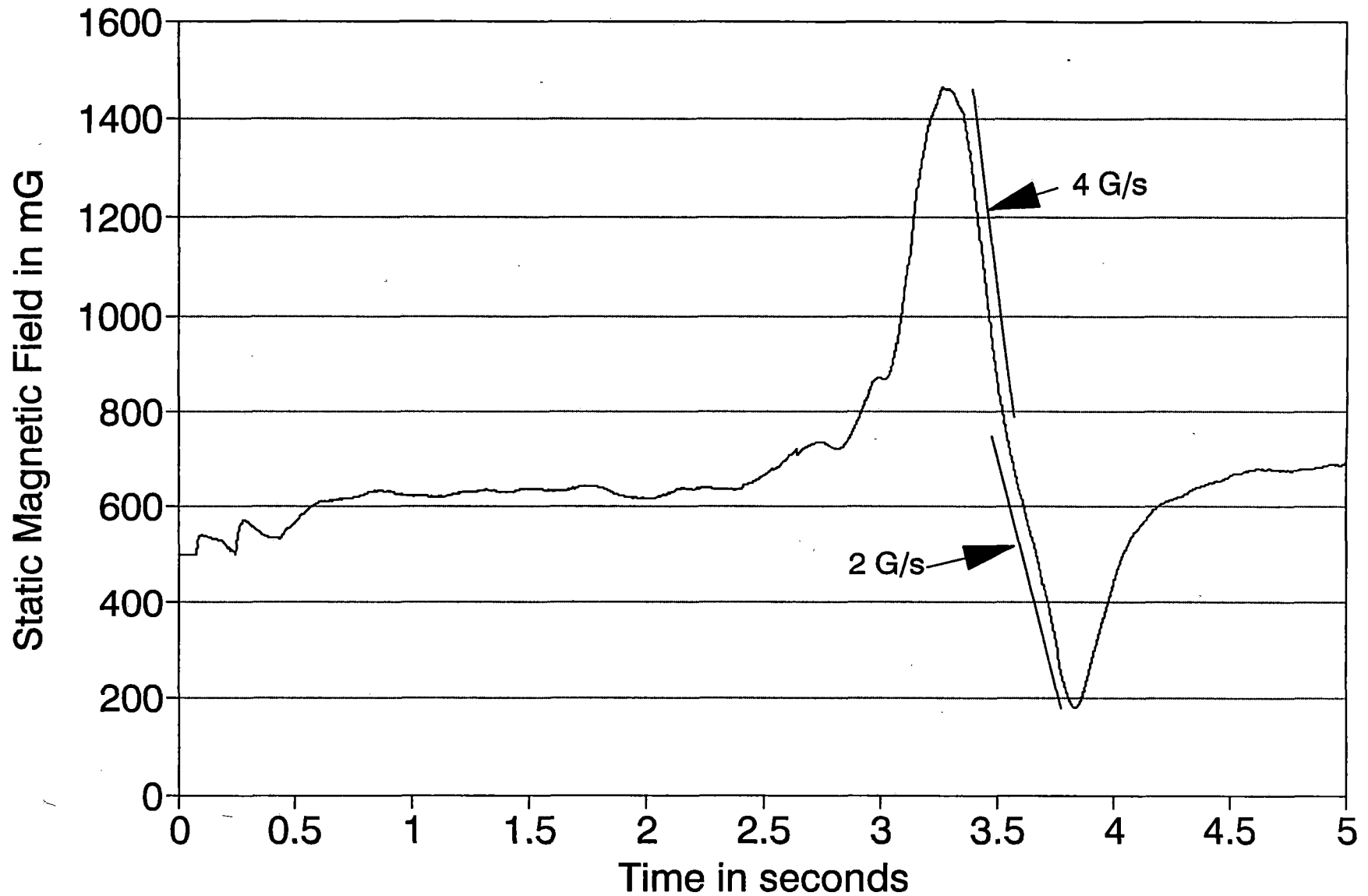

Figure 3-14 Time domain plot of the changing static field level in a 1000 series car showing time-rates-of-change of static field up to 4 gauss per second.

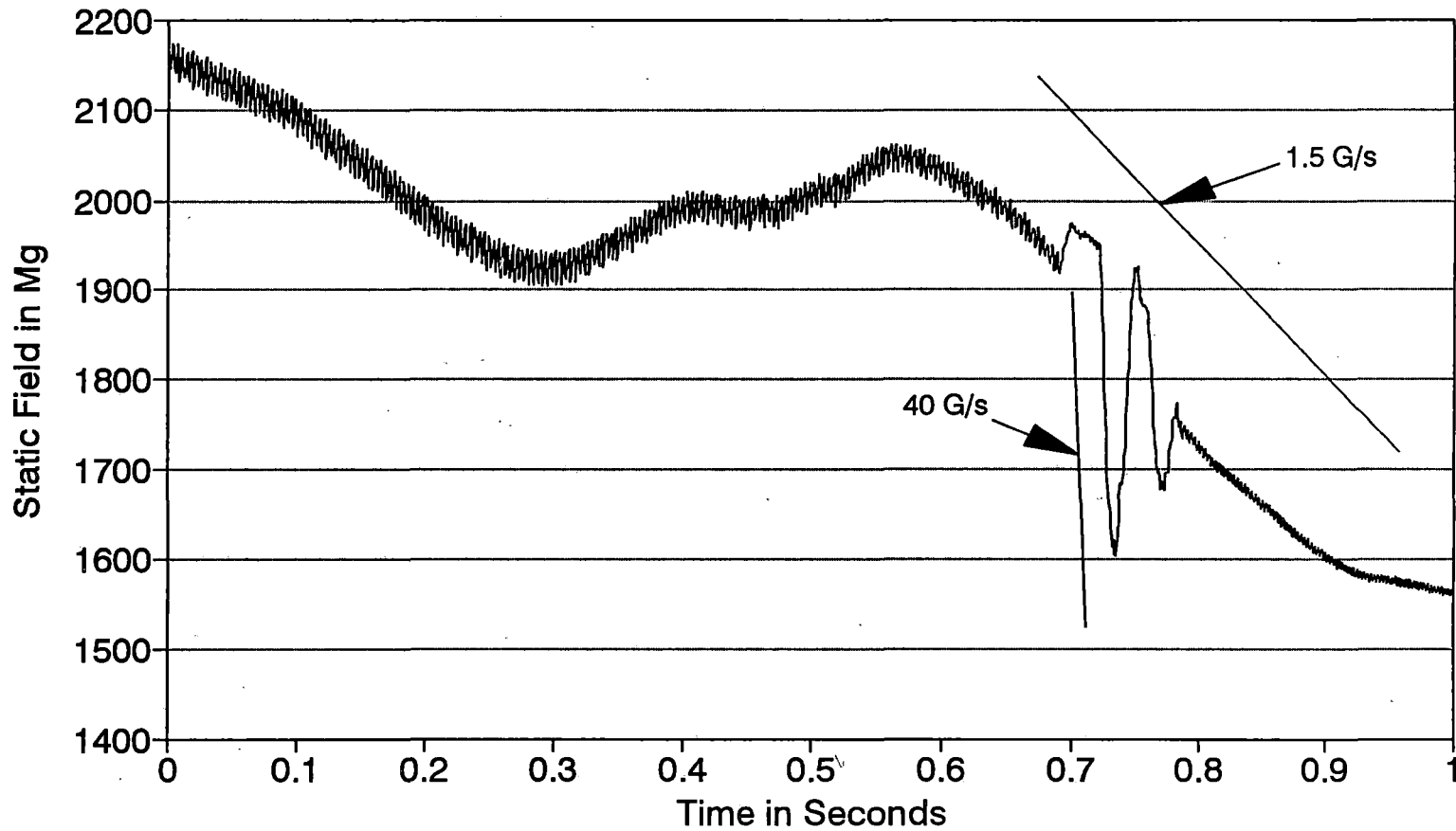

Figure 3-15

Time domain plot of the changing static field level near the center of a 3000 series car showing average rates of change, chopper ripple and an apparent transient field episode.

3.5 EMDEX-II Data

Magnetic field levels measured by the *MultiWave*™ System or DAT recorder provide detailed documentation of magnetic field levels at a few discrete locations within the coaches but do not factor in the possibility that passengers moving about the coaches may encounter high fields from specific, localized sources. To examine the extent to which spot measurements of magnetic fields can be generalized to passenger exposure, two members of the measurement team wore EMDEX-II personal magnetic field exposure monitors.

For these tests, the instruments were used in the "broadband" mode which yielded the widest frequency response (nominally a 3 db bandwidth between 40 Hz and 800 Hz) and therefore provided the instrument's most complete measurement of ELF magnetic fields. The EMDEX-II monitors lack the ability to measure static magnetic fields or the low frequency components produced by changes in the static field. Since the 1000 and 2000 series cars were found not to have time varying magnetic field components within the frequency passband of the EMDEX monitors, no data are presented for those cars.

The EMDEX-II units were mostly worn waist high, while wandering about the approximate vicinity of the car where the other measurements were being made or seated in a passenger seat while traveling between measurement sites. In one instance, while making measurements at the center of a 3000 series car, EMDEX number one was used as a survey meter to probe for areas of unusually high magnetic field strength. Consequently, those readings do not represent "typical" ELF magnetic field levels.

Table 3-3 shows the statistical minimum, average and maximum values obtained by the EMDEX-II recorders in the passenger area of 3000 series cars. Six sets of recordings are summarized, corresponding to different trips in different parts of the car. There is also a notation as to whether other measurements were in progress at the same time and where, because the EMDEX wearers are presumed to be in that vicinity.

3.6 Summary of Magnetic Field Levels

As discussed in the preceding subsections, the predominant magnetic field sources in the passenger areas of the Metrorail cars appear to be traction power control equipment beneath the floor of the cars and possible current in the loop created by the third rail and track return circuit. Consequently, tabulations of magnetic field level provided in this subsection give field values at various heights above the floor. These fields are predominantly static with low frequency time varying components resulting from fluctuations in the static field level. However, large time varying fields are found near the center of the 3000 series cars

TABLE 3-3

STATISTICAL SUMMARY OF MAGNETIC FIELD LEVELS
RECORDED IN 3000 SERIES CARS USING
EMDEX-II RECORDERS

LOCATION	EMDEX-II #	MINIMUM	AVERAGE	MAXIMUM
FRONT MEASUREMENT	PERSON 1	0.3 mG	2.3 mG	11.3 mG
	PERSON 2	0.3 mG	2.8 mG	13.9 mG
	COMBINED	0.3 mG	2.6 mG	13.9 mG
CENTER MEASUREMENT	PERSON 1	0.3 mG	81.2 mG	212 mG
	PERSON 2	0.2 mG	14.4 mG	68 mG
	COMBINED	0.2 mG	47.8 mG	212 mG
CENTER MEASUREMENT	PERSON 1	0.2 mG*	150.3 mG*	2138 mG*
	PERSON 2	0.2 mG	13.2 mG	103 mG
	COMBINED	0.2 mG*	81.8 mG*	2138 mG*
CENTER MEASUREMENT	PERSON 1	0.3 mG	53.7 mG	168 mG
	PERSON 2	0.2 mG	20.3 mG	157 mG
	COMBINED	0.2 mG	37.0 mG	168 mG
REAR MEASUREMENT	PERSON 1	0.3 mG	1.9 mG	7.4 mG
	PERSON 2	0.3 mG	1.9 mG	12.4 mG
	COMBINED	0.3 mG	1.9 mG	12.4 mG
PASSENGER SEAT	PERSON 1	0.2 mG	1.3 mG	7.8 mG
	PERSON 2	0.3 mG	2.1 mG	9.9 mG
	COMBINED	0.2 mG	1.7 mG	9.9 mG

* Note that there is a large difference between the two recordings. The reason for this is that Person 1 was intentionally experimenting in trying to find local high field areas.

which use 273 Hz semiconductor choppers to control the amount of electric power supplied to the traction motors.

Tables 3-4 through 3-8 summarize the magnetic field levels measured with the repetitive waveform technique in the center and rear of 1000 and 2000 series cars as well as in the rear of the 3000 series car. Each table shows the minimum, maximum and average field levels as well as the standard deviation and the coefficient of variation for the repetitive waveform datasets listed in the title heading. Each table provides the statistics at four heights above the floor for the static field, the total time varying field in the

frequency range from 5 Hz to 2560 Hz, and the time varying field in various smaller frequency bands. Because the magnetic field levels are similar in magnitude in all frequency bands at both locations in the 1000 series cars (Tables 3-4 and 3-5), both locations in the 2000 series cars (Tables 3-6 and 3-7), and in the rear of the 3000 series cars (Table 3-8), all of the data from the relevant datasets are pooled and summarized statistically in Table 3-9. The magnetic field values presented in this summary table are consistent with static field levels measured with the DAT (Table 3-2) and time varying field levels measured in the rear of the 3000 series cars with the EMDEX (Table 3-3 and allowing for the fact that the EMDEX does not respond to time-varying fields below 40 Hz). These field values represent the magnitude of magnetic fields generally encountered in WMATA Metrorail cars.

The central area of the 3000 series car has a unique magnetic field environment which is fundamentally different from the general field environment found in other cars or toward the front or rear of this car. Both the static and time varying magnetic fields are much larger in the center of the 3000 series cars, especially near the floor. Table 3-10 presents a summary of the static field levels at various heights above the floor at the center of the car. As mentioned earlier, the high static field levels near the floor occasionally exceeded the range of the magnetometers. When that occurred, the field values were estimated by extrapolation from simultaneous measurements at greater heights above the floor.

The statistical summary of the magnitude of the time varying magnetic fields in the center of the 3000 series car is presented in Table 3-11. These data were measured with the coil-type sensors so there are no saturation difficulties with which to contend. Since these sensors do not respond to static fields, there are no static field values reported in the table. It is difficult to make a quantitative comparison between field values reported in Table 3-11 and field values measured with the EMDEX-II recorders given in Table 3-3 because of the rapid attenuation of the magnetic field as one moves away the under-floor source, presumably the smoothing reactor. Nevertheless, the data are generally consistent. Average and maximum field values reported by the EMDEX are within the range that would be expected within a few meters of the source based on

TABLE 3-4

SUMMARY STATISTICS FOR MAGNETIC FIELD LEVELS
MEASURED IN THE CENTER OF A 1000 SERIES CAR

MET001 - CENTER OF CAR #1173		TOTAL OF 18 SAMPLES				
FREQUENCY BAND	HEIGHT ABOVE FLOOR (cm)	MINIMUM MAGNETIC FIELD (mG)	MAXIMUM MAGNETIC FIELD (mG)	AVERAGE MAGNETIC FIELD (mG)	STANDARD DEVIATION (mG)	COEFFICIENT OF VARIATION (%)
STATIC	10	205.11	4395.54	1779.76	1134.12	63.72
	60	172.01	2964.69	984.82	699.25	71.00
	110	233.17	1988.68	749.85	443.06	59.09
	160	290.89	1319.42	742.89	291.48	39.24
5-45Hz LOW FREQ	10	0.84	64.48	17.89	17.05	95.32
	60	0.53	28.06	9.23	8.01	86.80
	110	0.33	34.65	7.48	8.16	109.10
	160	0.39	60.79	9.54	15.09	158.29
50-60Hz PWR FREQ	10	0.25	5.59	1.89	1.50	79.04
	60	0.13	2.86	1.20	0.98	82.11
	110	0.27	3.77	0.90	0.85	94.87
	160	0.10	5.87	0.90	1.37	152.13
65-300Hz PWR HARM	10	0.22	5.58	2.53	2.04	80.48
	60	0.22	4.40	1.59	1.30	81.73
	110	0.20	6.13	1.27	1.39	109.52
	160	0.22	9.43	1.42	2.17	153.27
305-2560Hz HIGH FREQ	10	0.18	2.37	1.09	0.85	77.55
	60	0.12	2.24	0.71	0.61	85.96
	110	0.08	3.12	0.58	0.72	123.80
	160	0.07	4.79	0.70	1.11	159.58
5-2560Hz ALL FREQ	10	0.93	64.84	18.28	17.17	93.93
	60	0.60	28.46	9.51	8.16	85.84
	110	0.49	35.53	7.68	8.33	108.42
	160	0.47	61.98	9.73	15.34	157.69

TABLE 3-5

SUMMARY STATISTICS FOR MAGNETIC FIELD LEVELS
MEASURED IN THE REAR OF A 1000 SERIES CAR

MET002 - REAR OF CAR #1173		TOTAL OF 14 SAMPLES				
FREQUENCY BAND	HEIGHT ABOVE FLOOR (cm)	MINIMUM MAGNETIC FIELD (mG)	MAXIMUM MAGNETIC FIELD (mG)	AVERAGE MAGNETIC FIELD (mG)	STANDARD DEVIATION (mG)	COEFFICIENT OF VARIATION (%)
STATIC	10	428.08	1637.63	1147.56	371.76	32.40
	60	263.70	1133.03	762.76	241.95	31.72
	110	339.92	846.04	565.79	160.71	28.41
	160	286.04	765.78	533.94	152.66	28.59
5-45Hz LOW FREQ	10	1.22	12.82	7.50	4.05	53.94
	60	0.78	14.92	6.73	4.67	69.45
	110	0.64	21.33	7.12	6.33	88.89
	160	0.60	39.95	10.19	11.01	108.02
50-60Hz PWR FREQ	10	0.21	2.50	0.88	0.68	78.08
	60	0.14	1.68	0.67	0.51	76.83
	110	0.21	1.92	0.74	0.55	74.72
	160	0.10	3.34	0.82	0.88	108.43
65-300Hz PWR HARM	10	0.31	3.81	1.12	0.89	79.99
	60	0.29	2.75	0.99	0.76	77.18
	110	0.23	3.09	1.06	0.92	86.99
	160	0.22	5.29	1.25	1.42	113.15
305-2560Hz HIGH FREQ	10	0.16	1.22	0.51	0.28	53.97
	60	0.11	1.16	0.47	0.31	67.11
	110	0.08	1.55	0.49	0.46	93.11
	160	0.08	2.68	0.61	0.72	117.74
5-2560Hz ALL FREQ	10	1.30	13.09	7.69	4.14	53.87
	60	0.91	15.02	6.87	4.73	68.92
	110	0.75	21.69	7.26	6.42	88.39
	160	0.65	40.53	10.32	11.15	108.03

TABLE 3-6

SUMMARY STATISTICS FOR MAGNETIC FIELD LEVELS
MEASURED IN THE CENTER OF A 2000 SERIES CAR

MET028 - CENTER OF A 2000 SERIES CAR - IN MOTION			TOTAL OF 24 SAMPLES			
FREQUENCY BAND	HEIGHT ABOVE FLOOR (cm)	MINIMUM MAGNETIC FIELD (mG)	MAXIMUM MAGNETIC FIELD (mG)	AVERAGE MAGNETIC FIELD (mG)	STANDARD DEVIATION (mG)	COEFFICIENT OF VARIATION (%)
STATIC	10	415.08	4713.82	1458.56	1648.91	113.05
	60	370.75	3912.45	1157.03	1380.80	119.34
	110	357.05	2890.56	923.47	986.74	106.85
	160	382.52	2293.28	825.69	737.70	89.34
5-45Hz LOW FREQ	10	1.57	24.73	9.74	8.33	85.55
	60	1.02	10.45	5.24	3.31	63.13
	110	0.53	8.27	5.11	2.84	55.55
	160	0.40	14.50	7.64	5.94	77.75
50-60Hz PWR FREQ	10	0.19	3.09	1.14	1.08	95.07
	60	0.14	1.27	0.59	0.42	70.12
	110	0.17	1.02	0.65	0.35	53.73
	160	0.11	1.70	0.76	0.59	77.74
65-300Hz PWR HARM	10	0.38	3.29	1.83	1.11	60.92
	60	0.29	1.80	1.02	0.59	58.06
	110	0.33	1.42	0.99	0.50	50.47
	160	0.19	2.68	1.21	0.96	78.96
305-2560Hz HIGH FREQ	10	0.44	3.35	1.31	1.06	80.70
	60	0.18	1.11	0.63	0.35	56.04
	110	0.09	1.06	0.54	0.35	65.77
	160	0.08	1.59	0.65	0.56	86.41
5-2560Hz ALL FREQ	10	1.68	25.16	10.24	8.28	80.89
	60	1.09	10.71	5.43	3.36	61.81
	110	0.65	8.48	5.28	2.90	54.83
	160	0.46	14.93	7.81	6.06	77.57

TABLE 3-7

SUMMARY STATISTICS FOR MAGNETIC FIELD LEVELS
MEASURED IN THE REAR OF A 2000 SERIES CAR

MET027- REAR OF A 2000 SERIES CAR		TOTAL OF 11 SAMPLES				
FREQUENCY BAND	HEIGHT ABOVE FLOOR (cm)	MINIMUM MAGNETIC FIELD (mG)	MAXIMUM MAGNETIC FIELD (mG)	AVERAGE MAGNETIC FIELD (mG)	STANDARD DEVIATION (mG)	COEFFICIENT OF VARIATION (%)
STATIC	10	14.06	2249.66	1765.59	649.05	36.76
	60	18.57	1351.63	1023.53	361.22	35.29
	110	21.86	965.25	686.67	247.50	36.04
	160	19.92	873.61	557.55	207.87	37.28
5-45Hz LOW FREQ	10	0.01	18.95	4.93	5.23	105.98
	60	0.00	10.66	3.22	3.01	93.33
	110	0.02	5.91	2.53	1.59	62.94
	160	0.00	6.51	3.75	2.43	64.80
50-60Hz PWR FREQ	10	0.00	3.23	0.91	1.01	111.18
	60	0.00	2.22	0.63	0.72	113.85
	110	0.00	1.18	0.52	0.38	74.25
	160	0.00	1.22	0.52	0.37	69.92
65-300Hz PWR HARM	10	0.01	3.94	1.12	1.11	99.12
	60	0.00	2.56	0.81	0.75	92.01
	110	0.01	1.46	0.62	0.41	65.40
	160	0.05	1.16	0.74	0.37	49.81
305-2560Hz HIGH FREQ	10	0.04	5.00	1.74	1.28	73.15
	60	0.02	3.74	1.20	0.95	79.42
	110	0.03	2.31	0.84	0.59	70.14
	160	0.03	1.90	0.73	0.48	64.99
5-2560Hz ALL FREQ	10	0.04	20.25	5.54	5.47	98.65
	60	0.02	11.79	3.65	3.25	89.17
	110	0.04	6.62	2.81	1.74	62.14
	160	0.06	6.68	3.96	2.47	62.37

TABLE 3-8

SUMMARY STATISTICS FOR MAGNETIC FIELD LEVELS
IN THE REAR OF A 3000 SERIES CAR

MET008 - REAR OF CAR #3012		TOTAL OF 16 SAMPLES				
FREQUENCY BAND	HEIGHT ABOVE FLOOR (cm)	MINIMUM MAGNETIC FIELD (mG)	MAXIMUM MAGNETIC FIELD (mG)	AVERAGE MAGNETIC FIELD (mG)	STANDARD DEVIATION (mG)	COEFFICIENT OF VARIATION (%)
STATIC	10	1026.45	4708.21	1837.37	948.33	51.61
	60	543.36	4538.66	1254.32	1012.84	80.75
	110	355.19	3462.37	858.29	783.37	91.27
	160	262.81	2467.74	683.72	533.51	78.03
5-45Hz LOW FREQ	10	4.32	22.79	12.14	5.98	49.27
	60	2.67	21.84	10.53	6.35	60.37
	110	1.73	28.79	10.93	8.49	77.71
	160	1.29	55.66	16.64	17.46	104.93
50-60Hz PWR FREQ	10	0.57	2.79	1.40	0.70	49.74
	60	0.40	2.14	1.14	0.61	53.75
	110	0.30	2.60	1.09	0.68	62.39
	160	0.23	4.74	1.42	1.42	100.38
65-300Hz PWR HARM	10	1.06	5.94	3.38	1.38	40.77
	60	1.02	4.16	2.51	1.08	43.15
	110	0.82	4.28	2.05	1.05	51.43
	160	0.60	7.56	2.51	2.15	85.94
305-2560Hz HIGH FREQ	10	0.59	4.57	1.90	1.08	56.83
	60	0.56	2.91	1.45	0.77	52.84
	110	0.40	2.38	1.13	0.65	57.79
	160	0.33	3.98	1.34	1.14	85.26
5-2560Hz ALL FREQ	10	5.03	23.72	13.01	5.84	44.85
	60	3.06	22.36	11.10	6.29	56.60
	110	2.00	29.32	11.34	8.46	74.61
	160	1.97	56.50	17.04	17.58	103.16

TABLE 3-9

SUMMARY STATISTICS FOR MAGNETIC FIELD LEVELS
 IN THE CENTER AND REAR OF ALL CARS
 EXCEPT CENTER OF THE 3000 SERIES CAR

MET001, 002, 008, 027, 028 - ALL CARS, VERTICAL		TOTAL OF 65 SAMPLES				
FREQUENCY BAND	HEIGHT ABOVE FLOOR (cm)	MINIMUM MAGNETIC FIELD (mG)	MAXIMUM MAGNETIC FIELD (mG)	AVERAGE MAGNETIC FIELD (mG)	STANDARD DEVIATION (mG)	COEFFICIENT OF VARIATION (%)
STATIC	10	14.06	4713.82	1625.73	965.72	59.40
	60	18.57	4538.66	1025.77	762.77	74.36
	110	21.86	3462.37	742.23	548.33	73.88
	160	19.92	2467.74	659.60	391.42	59.34
5-45Hz LOW FREQ	10	0.01	64.48	11.29	11.02	97.56
	60	0.00	28.06	7.62	6.33	83.05
	110	0.02	34.65	7.19	7.17	99.67
	160	0.00	60.79	10.27	13.36	130.09
50-60Hz PWR FREQ	10	0.00	5.59	1.32	1.11	84.05
	60	0.00	2.86	0.92	0.75	81.85
	110	0.00	3.77	0.82	0.66	80.12
	160	0.00	5.87	0.93	1.13	120.92
65-300Hz PWR HARM	10	0.01	5.94	2.13	1.69	79.11
	60	0.00	4.40	1.50	1.17	77.98
	110	0.01	6.13	1.28	1.11	86.64
	160	0.05	9.43	1.52	1.79	118.31
305-2560Hz HIGH FREQ	10	0.04	5.00	1.30	1.05	80.68
	60	0.02	3.74	0.92	0.75	81.47
	110	0.03	3.12	0.74	0.64	86.69
	160	0.03	4.79	0.84	0.94	112.10
5-2560Hz ALL FREQ	10	0.04	64.84	11.80	11.08	93.82
	60	0.02	28.46	7.96	6.42	80.63
	110	0.04	35.53	7.44	7.26	97.46
	160	0.06	61.98	10.50	13.53	128.78

3-35

TABLE 3-10

**SUMMARY STATISTICS FOR STATIC MAGNETIC FIELD LEVELS
MEASURED IN THE CENTER OF A 3000 SERIES CAR
(CORRECTED FOR SENSOR SATURATION AS DISCUSSED IN TEXT)**

MET004, 006, 007 - CENTER OF AISLE, CENTER OF CAR 3012			TOTAL OF 24 SAMPLES			
FREQUENCY BAND	HEIGHT ABOVE FLOOR (cm)	MINIMUM MAGNETIC FIELD (mG)	MAXIMUM MAGNETIC FIELD (mG)	AVERAGE MAGNETIC FIELD (mG)	STANDARD DEVIATION (mG)	COEFFICIENT OF VARIATION (%)
STATIC	10	435.56	131469.00	14285.39	27537.01	192.76
	60	655.65	23732.00	2684.58	4927.35	183.54
	110	308.10	5029.44	1008.00	1074.44	106.59
	160	266.97	3666.61	841.46	685.17	81.43

TABLE 3-11

SUMMARY STATISTICS FOR TIME VARYING MAGNETIC FIELD LEVELS
MEASURED IN THE CENTER OF A 3000 SERIES CAR

MET049 - CENTER OF A 3000 SERIES CAR		TOTAL OF 34 SAMPLES				
FREQUENCY BAND	HEIGHT ABOVE FLOOR (cm)	MINIMUM MAGNETIC FIELD (mG)	MAXIMUM MAGNETIC FIELD (mG)	AVERAGE MAGNETIC FIELD (mG)	STANDARD DEVIATION (mG)	COEFFICIENT OF VARIATION (%)
5-45Hz LOW FREQ	10	6.10	2892.17	562.16	532.03	94.64
	60	4.76	423.92	98.53	80.03	81.23
	110	4.06	139.46	33.88	24.93	73.58
	160	5.70	71.44	18.56	12.52	67.47
50-60Hz PWR FREQ	10	1.23	309.21	70.29	56.62	80.54
	60	1.05	50.82	12.59	9.18	72.90
	110	0.91	16.27	4.37	2.93	66.96
	160	0.66	8.32	2.35	1.57	66.88
65-300Hz PWR HARM	10	1.36	1326.18	738.81	456.98	61.85
	60	1.53	248.63	133.47	81.88	61.35
	110	1.51	86.06	44.17	26.89	60.88
	160	1.21	43.11	22.03	13.28	60.30
305-2560Hz HIGH FREQ	10	1.11	355.32	230.90	121.29	52.53
	60	1.06	61.60	41.19	21.28	51.68
	110	0.99	19.92	13.65	6.82	49.96
	160	0.77	9.91	6.84	3.32	48.56
5-2560Hz ALL FREQ	10	7.13	2986.99	997.97	657.03	65.84
	60	5.31	443.59	177.78	106.55	59.94
	110	4.55	145.92	60.23	32.66	54.23
	160	6.00	74.62	31.32	15.64	49.94

the *MultiWave*™ data. Furthermore, the maximum values recorded by the EMDEX used as a survey meter near floor level in the near vicinity of the field source reported values nearly as large as those measured with the *MultiWave*™ System. Larger values are expected in the *MultiWave*™ measurements because of its wider bandwidth inclusion of low frequency and high frequency components of the field missed by the more limited bandwidth of the EMDEX meters.

3.7 Summary of Electric Field Sources and Levels

Electric field measurements within the Metrorail cars did not detect time varying electric fields greater than 1 V/m in any of the measuring positions in any of the cars. That is as expected, because ultra low frequency (ULF) and extreme low frequency (ELF) electric fields are effectively attenuated by conductive barriers such as the metallic bodies of the cars. Consequently, significant electric fields from external sources such as the commercial power system were not expected to be present inside the coaches.

The displacement current measurement approach employed for the electric field measurements within the cars does not respond to static fields such as those produced by the static voltage on the third rail. Nevertheless, electric fields produced by the voltage on the third rail will not penetrate the conductive car bodies. Therefore, even though static electric field levels could not be measured, it is highly unlikely that any exist within the cars aside from those produced by static charges on passengers and their clothing.

4.0 ENGINEER'S COMPARTMENT MEASUREMENTS

The engineer's compartment in the WMATA Metrorail cars is a small compartment at the end of each car. Consequently, all of the possible sources of magnetic field discussed in Section 3 for the passenger section of the car are also possible sources of field for the engineer's compartment. In addition, the various control equipment within the compartment represent a unique potential source applying to that compartment only. Therefore, magnetic field measurements were made in the engineer's compartment to determine if the field environment was different in that compartment and to quantify the field environment at the engineer's workplace.

4.1 Measurement Locations

The general layout of a WMATA Metrorail car is shown in Figure 3-1. The numbered measurement locations are keyed to datasets in Tables 2-1 and 2-2 and to the data in the corresponding appendices. Measurements in the passenger sections of the cars were reported in the preceding section. This section reports the results of measurements made in the engineer's compartment which is the location with key number 8 in Figure 3-1.

Magnetic fields were measured along a vertical profile at the engineer's workplace by positioning the sensor staff vertically at the center of the front edge of the engineer's seat. All measurements were made in the unoccupied rear engineer's compartment in order to avoid interruption of the engineer. This also permitted the reference probe to be placed on the engineer's seat for continuous field measurements with the DAT. Measurements were made at the same locations for all three types of cars while in revenue service on May 19, 1992. Measurements in the engineer's compartment of the 1000 and 3000 series cars were made on the portion of the Red Line between the Shady Grove and Van Ness-UDC Stations. Measurements in the rear cab of the 2000 series car had to be made on the Green Line between the Gallery Place and U Street-Cardozo Stations because there were no cars of that type operating on the Red Line.

4.2 Repetitive Waveform Datasets

There are three repetitive waveform datasets quantifying magnetic field characteristics within the rear engineer's compartments of the Metrorail cars. They are labeled MET003, MET026, and MET009 for the 1000, 2000, and 3000 series cars, respectively. All of these datasets represent vertical profile measurements at distances of 10, 60, 110, and 160 cm above the floor of the compartment. Complete plots of field versus frequency over time, and field versus distance over time, are found in the appendices as indicated in Table 2-1. The appendices also contain notes about train

operating conditions, locations and, where pertinent, the presence of external field sources such as power lines or substations.

4.3 Magnetic Field Characteristics

Magnetic field measurements in the engineer's compartments demonstrated that the fields within the compartment were similar in all characteristics to those measured at the rear of the passenger compartments of the cars. Neither the frequency, spatial, nor temporal characteristics of the measured fields suggested significant contributions from sources unique to the engineer's compartment. Therefore, the description of magnetic field characteristics at the rear of the cars, provided in Section 3 above, applies to the engineer's compartment as well. Graphs of magnetic field versus frequency and time, and graphs of magnetic field versus height above the floor and time for the engineer's compartment are found in Appendices D, I, and W.

4.4 DAT Waveform Data

Magnetic field data from the reference probe of the *MultiWave*™ System was recorded continuously with a digital audio tape recorder, as described in Section 2.5. Continuous field data were measured on the engineer's seat of each of the three types of cars. Pertinent information about the time and duration of these measurements is contained in Table 2-2. Those recordings were analyzed as described in Section 3.4 above.

A statistical summary of static magnetic field levels measured by the DAT recording system on the engineer's seats of the Metrorail cars is presented in Table 4-1.

4.5 EMDEX-II Data

Because of the small size of the engineer's compartment, it was impractical to have an EMDEX-wearer in the compartment with the other measurement sensors. Therefore, they stood in the general vicinity of the compartment door or sat in one of the last passenger seats. Data recorded with the EMDEX recorders at the rear of the passenger's compartment during the engineer's compartment tests are included with other passenger compartment data in Table 3-3.

4.6 Summary of Magnetic Field Levels

As discussed in the preceding subsections, the predominant magnetic field sources in the passenger areas of the Metrorail cars appear to be traction power control equipment beneath the floor of the cars and also possibly current in the loop created by the third rail and track return circuit. Consequently, tabulations of

TABLE 4-1

SUMMARY OF STATIC MAGNETIC FIELD LEVELS RECORDED
IN THE ENGINEER'S SEAT OF A METRORAIL CAR RECORDED WITH
THE DIGITAL AUDIO TAPE RECORDER (DAT)

SERIES OF CAR	MEASUREMENT LOCATION		STATIC MAGNETIC FIELD MILLIGAUSS		
	(TAPE/REC.)	FIGURE #	LOCATION	MINIMUM	AVERAGE
1000 (1/2)	3-2	11	129	682	1698 *
2000 (1/10)	3-2	11	116	816	2076
3000 (1/5)	3-2	11	457	1469	3623

* Some portions of this record were saturated due to an insufficiently high range setting on the DAT. Therefore, the true maximum field is larger than indicated. The average value is not believed to be significantly affected due to the small portion of the total record where saturation occurred.

magnetic field level provided in the engineer's compartment give field values at various heights above the floor. These fields are predominantly static with low frequency time varying components resulting from fluctuations in the static field level.

Tables 4-2 through 4-4 summarize the magnetic field levels measured with the repetitive waveform technique in the rear engineer's compartment of the 1000, 2000, and 3000 series cars, respectively. Each table shows the minimum, maximum and average field levels, as well as the standard deviation and the coefficient of variation for the repetitive waveform datasets listed in the title heading. Each table provides the statistics at four heights above the floor for the static field, the total time varying field in the frequency range from 5 Hz to 2560 Hz, and the time varying field in various smaller frequency bands. Because the magnetic field levels are similar in magnitude in each of the frequency bands for all three cars, the data from the relevant datasets are pooled and summarized statistically in Table 4-5. The magnetic field values presented in this summary table are consistent with field values measured at the rear of the cars (Table 3-10), with static field levels measured in the engineer's seat with the DAT (Table 4-1), and time varying field levels measured in the rear of the 3000 series cars with the EMDEX (Table 3-3 and allowing for the

TABLE 4-2

**SUMMARY STATISTICS FOR MAGNETIC FIELD LEVELS
MEASURED IN THE ENGINEER'S COMPARTMENT
OF A 1000 SERIES CAR**

MET003 - IN FRONT OF OPERATORS SEAT, CAR #1173		TOTAL OF 27 SAMPLES				
FREQUENCY BAND	HEIGHT ABOVE FLOOR (cm)	MINIMUM MAGNETIC FIELD (mG)	MAXIMUM MAGNETIC FIELD (mG)	AVERAGE MAGNETIC FIELD (mG)	STANDARD DEVIATION (mG)	COEFFICIENT OF VARIATION (%)
STATIC	10	274.28	3042.39	805.31	655.14	81.35
	60	169.70	3148.44	680.01	734.84	108.06
	110	114.25	2582.07	540.46	637.31	117.92
	160	249.88	2310.96	616.54	571.48	92.69
5-45Hz LOW FREQ	10	0.62	29.66	14.33	8.90	62.13
	60	0.45	23.60	11.78	7.32	62.19
	110	0.69	28.68	12.07	8.02	66.46
	160	2.44	46.79	18.53	12.88	69.52
50-60Hz PWR FREQ	10	0.19	2.58	1.06	0.71	67.36
	60	0.06	1.90	0.82	0.55	67.58
	110	0.17	1.93	0.87	0.57	66.32
	160	0.06	3.05	1.21	0.90	74.91
65-300Hz PWR HARM	10	0.16	3.68	1.55	1.09	70.12
	60	0.19	3.16	1.30	0.86	66.22
	110	0.16	3.22	1.32	0.94	71.32
	160	0.21	4.59	1.88	1.40	74.34
305-2560Hz HIGH FREQ	10	0.12	1.87	0.82	0.53	64.63
	60	0.11	1.57	0.69	0.42	61.05
	110	0.09	1.55	0.67	0.48	71.61
	160	0.12	2.32	0.98	0.69	70.54
5-2560Hz ALL FREQ	10	0.74	29.76	14.51	8.96	61.75
	60	0.53	23.85	11.92	7.37	61.85
	110	0.76	28.87	12.21	8.07	66.08
	160	2.46	46.91	18.71	12.97	69.36

TABLE 4-3

SUMMARY STATISTICS FOR MAGNETIC FIELD LEVELS
 MEASURED IN THE ENGINEER'S COMPARTMENT
 OF A 2000 SERIES CAR

MET026 - IN FRONT OF OPERATOR'S SEAT IN A 2000 SERIES CAR TOTAL OF 9 SAMPLES						
FREQUENCY BAND	HEIGHT ABOVE FLOOR (cm)	MINIMUM MAGNETIC FIELD (mG)	MAXIMUM MAGNETIC FIELD (mG)	AVERAGE MAGNETIC FIELD (mG)	STANDARD DEVIATION (mG)	COEFFICIENT OF VARIATION (%)
STATIC	10	1110.41	2585.42	1554.05	487.82	31.39
	60	748.75	1781.85	1017.48	385.09	37.85
	110	408.40	1542.02	708.69	421.52	59.48
	160	192.13	1437.13	611.32	408.53	66.83
5-45Hz LOW FREQ	10	0.45	30.01	9.47	10.12	106.94
	60	0.32	16.87	5.83	6.72	115.33
	110	0.15	24.51	6.75	9.49	140.59
	160	0.31	47.40	11.03	16.52	149.80
50-60Hz PWR FREQ	10	0.20	3.45	0.88	1.06	119.94
	60	0.10	1.78	0.55	0.66	118.99
	110	0.18	2.03	0.68	0.74	109.73
	160	0.08	3.57	0.86	1.21	141.49
65-300Hz PWR HARM	10	0.31	6.27	1.75	1.99	113.82
	60	0.20	2.90	0.90	1.05	116.87
	110	0.23	3.31	1.01	1.22	121.45
	160	0.22	5.60	1.35	1.88	139.51
305-2560Hz HIGH FREQ	10	0.90	9.17	2.58	2.54	98.47
	60	0.35	3.48	0.96	0.99	103.27
	110	0.18	2.59	0.72	0.84	117.03
	160	0.14	2.85	0.84	0.99	118.54
5-2560Hz ALL FREQ	10	1.07	32.19	10.18	10.49	103.12
	60	0.53	17.56	6.06	6.86	113.14
	110	0.45	24.87	6.97	9.58	137.35
	160	0.41	47.94	11.21	16.67	148.68

TABLE 4-4

SUMMARY STATISTICS FOR MAGNETIC FIELD LEVELS
MEASURED IN THE ENGINEER'S COMPARTMENT
OF A 3000 SERIES CAR

MET009 - IN FRONT OF OPERATOR'S SEAT, CAR #3012					TOTAL OF 10 SAMPLES	
FREQUENCY BAND	HEIGHT ABOVE FLOOR (cm)	MINIMUM MAGNETIC FIELD (mG)	MAXIMUM MAGNETIC FIELD (mG)	AVERAGE MAGNETIC FIELD (mG)	STANDARD DEVIATION (mG)	COEFFICIENT OF VARIATION (%)
STATIC	10	661.86	3589.36	1336.16	813.27	60.87
	60	380.00	2695.17	749.46	699.23	93.30
	110	170.14	2107.86	507.83	579.16	114.05
	160	85.30	1802.29	470.56	482.36	102.51
5-45Hz LOW FREQ	10	0.73	33.48	18.59	11.06	59.48
	60	0.54	22.48	10.38	7.44	71.66
	110	0.44	25.08	9.47	8.11	85.64
	160	0.79	31.74	12.05	11.21	92.98
50-60Hz PWR FREQ	10	0.18	2.43	1.32	0.69	52.35
	60	0.12	1.72	0.83	0.49	58.59
	110	0.17	2.35	0.86	0.62	71.63
	160	0.18	3.12	1.16	0.95	82.11
65-300Hz PWR HARM	10	0.28	7.04	3.40	1.82	53.54
	60	0.18	3.15	1.73	0.86	50.07
	110	0.35	3.61	1.51	0.94	62.44
	160	0.42	4.93	1.94	1.44	74.29
305-2560Hz HIGH FREQ	10	0.35	2.83	1.49	0.68	45.67
	60	0.11	1.37	0.79	0.39	48.53
	110	0.09	1.74	0.72	0.47	65.27
	160	0.12	2.47	0.96	0.73	76.54
5-2560Hz ALL FREQ	10	0.87	33.81	19.18	10.90	56.83
	60	0.59	22.81	10.66	7.40	69.46
	110	0.60	25.50	9.69	8.15	84.10
	160	0.92	32.37	12.33	11.34	91.97

TABLE 4-5

SUMMARY STATISTICS FOR MAGNETIC FIELD LEVELS
 MEASURED IN THE ENGINEER'S COMPARTMENT
 OF ALL TYPES OF CARS

MET003, 009, 026 - IN FRONT OF OPERATOR'S SEAT, ALL CARS		TOTAL OF 46 SAMPLES				
FREQUENCY BAND	HEIGHT ABOVE FLOOR (cm)	MINIMUM MAGNETIC FIELD (mG)	MAXIMUM MAGNETIC FIELD (mG)	AVERAGE MAGNETIC FIELD (mG)	STANDARD DEVIATION (mG)	COEFFICIENT OF VARIATION (%)
STATIC	10	274.28	3589.36	1067.20	726.09	68.04
	60	169.70	3148.44	761.13	673.25	88.45
	110	114.25	2582.07	566.28	581.86	102.75
	160	85.30	2310.96	583.79	518.21	88.77
5-45Hz LOW FREQ	10	0.45	33.48	14.30	9.86	68.93
	60	0.32	23.60	10.31	7.44	72.20
	110	0.15	28.68	10.46	8.42	80.45
	160	0.31	47.40	15.65	13.48	86.09
50-60Hz PWR FREQ	10	0.18	3.45	1.08	0.78	72.26
	60	0.06	1.90	0.77	0.56	72.69
	110	0.17	2.35	0.83	0.61	73.52
	160	0.06	3.57	1.13	0.97	85.66
65-300Hz PWR HARM	10	0.16	7.04	1.99	1.62	81.23
	60	0.18	3.16	1.31	0.92	70.01
	110	0.16	3.61	1.30	0.99	76.25
	160	0.21	5.60	1.79	1.49	83.29
305-2560Hz HIGH FREQ	10	0.12	9.17	1.31	1.37	104.85
	60	0.11	3.48	0.76	0.56	73.93
	110	0.09	2.59	0.69	0.55	79.86
	160	0.12	2.85	0.94	0.75	79.16
5-2560Hz ALL FREQ	10	0.74	33.81	14.67	9.91	67.55
	60	0.53	23.85	10.50	7.47	71.20
	110	0.45	28.87	10.64	8.46	79.53
	160	0.41	47.94	15.85	13.58	85.64

fact that the EMDEX does not respond to time varying fields below 40 Hz). Therefore, these field values appear to well represent the magnitude of magnetic fields encountered in the engineer's compartment of WMATA Metrorail cars even though the sample size is modest.

4.7 Summary of Electric Field Sources and Levels

Significant levels of time varying electric fields (greater than 1 V/m) were not present within the engineer's compartment of the Metrorail cars. That is expected because electric fields are effectively attenuated by conductive barriers such as the metallic bodies of the cars and the fact that all of the electrical apparatus on the compartment was housed in metal enclosures.

5.0 MEASUREMENTS ALONG THE WAYSIDE

Measurements along the wayside are conducted to determine the magnetic field in the vicinity of the WMATA Metrorail line. The data in this section shows the contribution to the environmental field made by the Metrorail System and the attenuation of the field with distance away from the tracks.

5.1 Measurement Locations

Measurements were made at two different locations, exemplifying two distinctly different situations. The two locations were a highway underpass at Rockville and an open space along the track south of Shady Grove. Both locations were situated along the Metrorail Red Line which starts at the Shady Grove Station. Data was collected using the *MultiWave*™ System sensor staff and reference probe, and the EMDEX-II and the DAT recordings. The DAT recorder used magnetic field data from the reference probe as input and was physically located near the probe. As previously mentioned, the *MultiWave*™ staff has four probes located at distances of 10, 60, 110 and 160 cm along its length.

Figure 5-1 is a top view of the highway underpass just north of the Rockville Station. Measurements were made at this point to determine if there were significant magnetic field levels beneath the third rail and tracks. The staff was in a vertical position at the edge of the sidewalk nearest the road directly under the northbound tracks. The reference probe was also located at the edge of the sidewalk, 10 cm above the pavement, but at a point half way between the two train track centerlines. The underside of the Metrorail bridge was approximately 17.5 feet above the sidewalk surface. Measurements were taken on May 20, 1992 from 14:17 to 14:33 hours.

Figure 5-2 is the schematic of the measurement location in the open space along the track between Shady Grove and Rockville. The track is at ground level and parallels Maryland Route 355. A steel chain link fence approximately 12 to 15 feet from the nearest track separates the tracks from the sidewalk and roadway. The staff was placed horizontally against the fence. The reference probe was located at a distance of approximately 8 feet from the fence at the curb of the road. Measurements were taken on May 20, 1992 from 14:53 to 14:57 hours.

5.2 Repetitive Waveform Datasets

The datasets that contain the information from the two locations described in Section 5.1 are MET054, MET055 and MET056. Table 5-1 repeats the pertinent summary information about these datasets, also shown in Table 2-1, including the number of samples and the appendix which contains the complete set of collected data. All

5-2

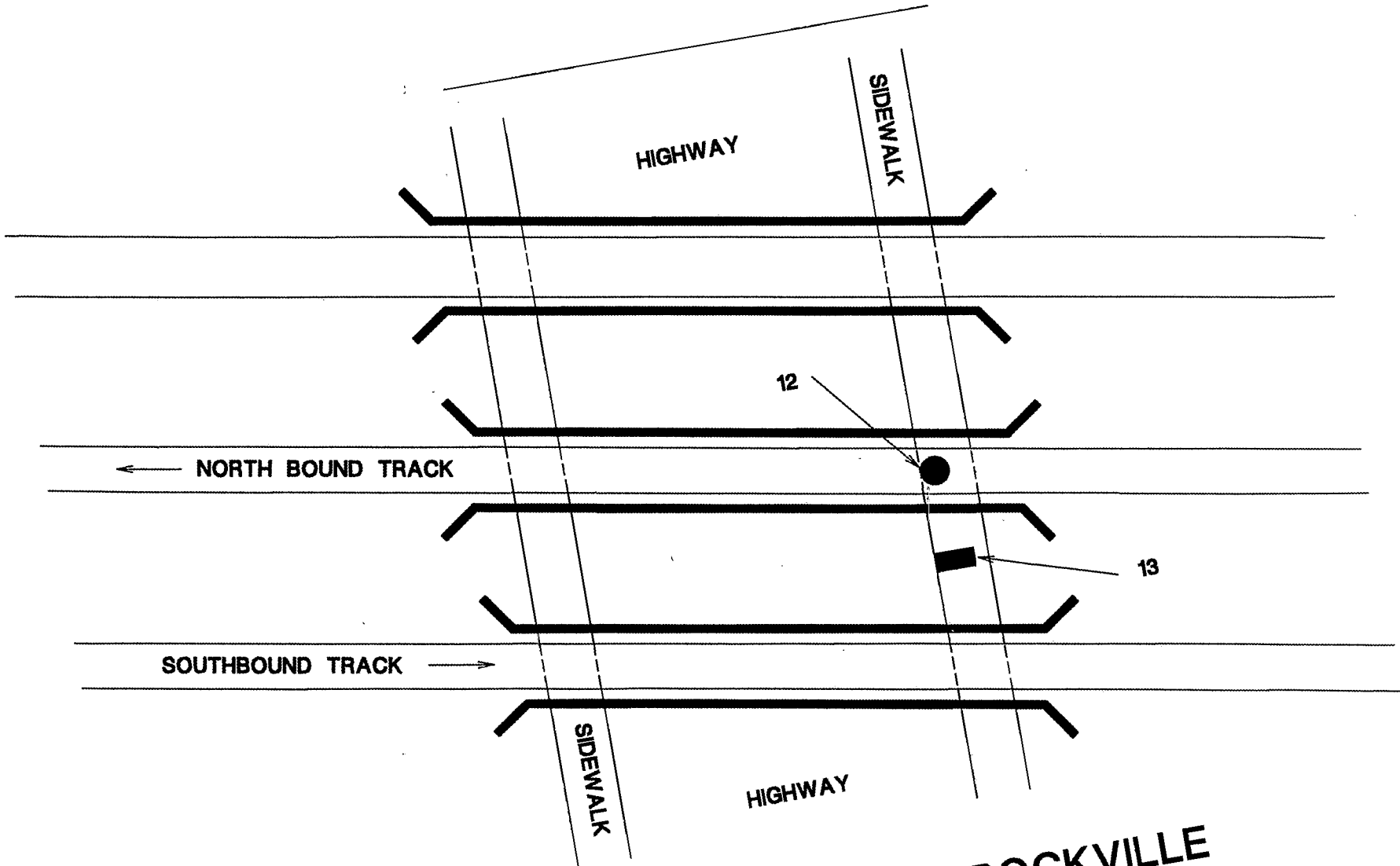

HIGHWAY UNDERPASS AT ROCKVILLE

Figure 5-1 Repetitive waveform measurement location at highway underpass at Rockville.

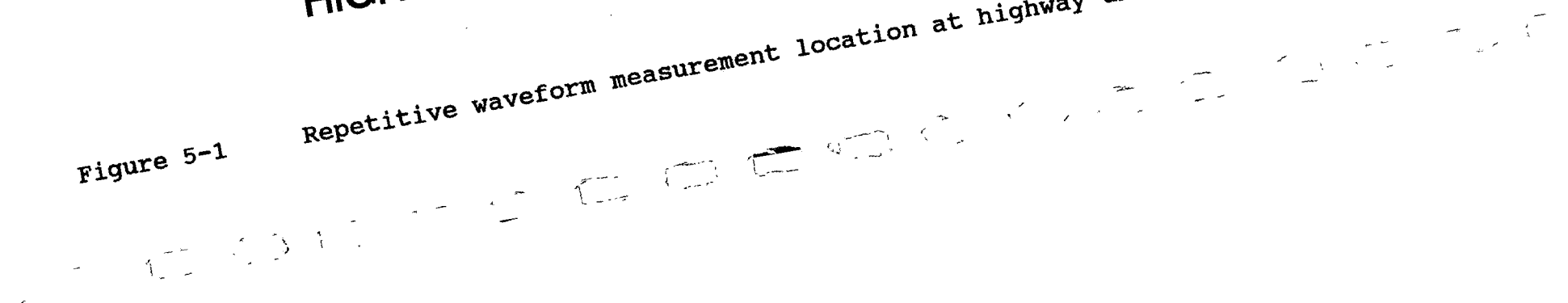

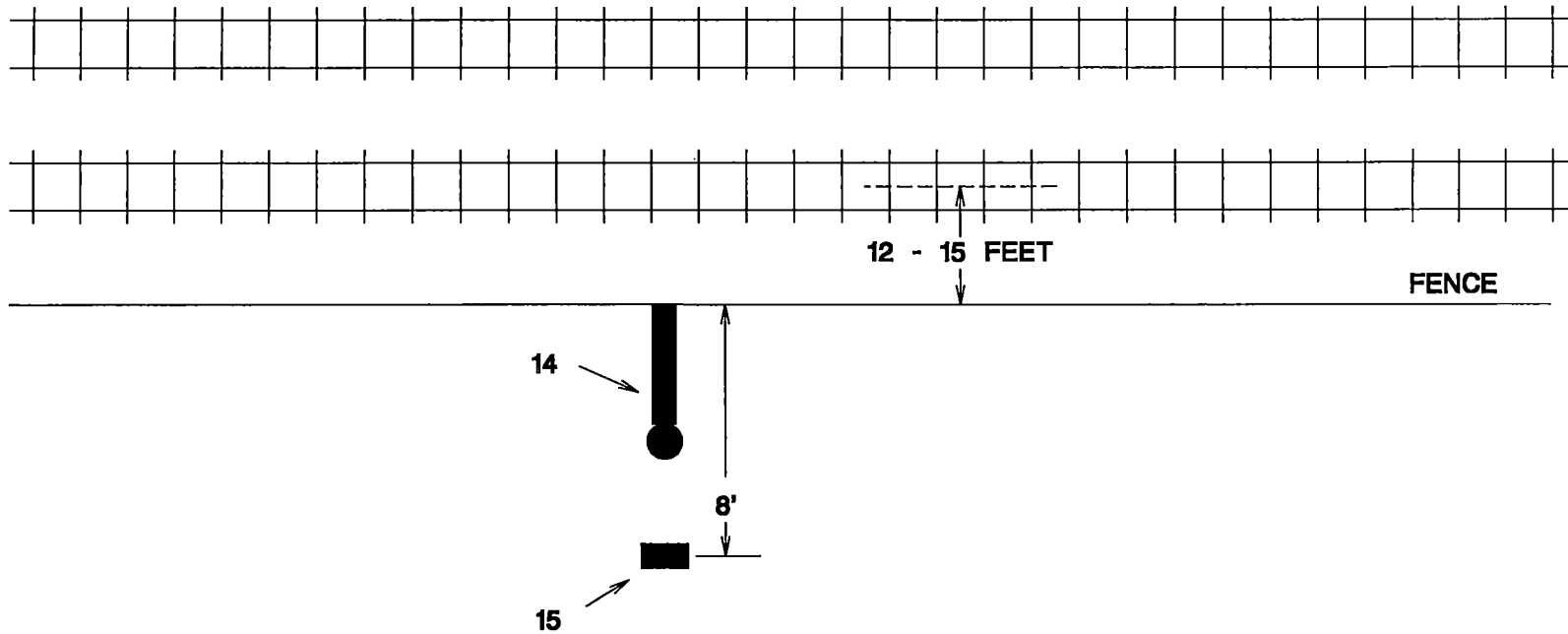

AT WAYSIDE, SOUTH OF SHADY GROVE

Figure 5-2 Repetitive waveform measurement location at wayside, south of Shady Grove.

datasets were taken at sample intervals of 5 seconds (12 per minute).

A train passed by during the recording of the first dataset at the highway underpass. The second dataset at the highway underpass began just as the train crossed the overhead bridge. Two 3000 series trains passed while recording along the wayside, dataset MET056.

TABLE 5-1

REPETITIVE MAGNETIC FIELD WAVEFORM DATASETS
MEASURED ALONG THE WAYSIDE

DATA FILE NUMBER	DATE/ TIME	FIG. # LOCAT'N	# OF SAMPLES & RATE	APPENDIX	REMARKS
MET054	MAY 20 14:17-14:28	5-1 12	133 5 SEC	AX	UNDERPASS TRAIN PASS
MET055	MAY 20 14:33-14:33	5-1 12	6 5 SEC	AY	UNDERPASS
MET056	MAY 20 14:53-14:57	5-2 14	15 5 SEC	AZ	OPEN SPACE TWO 3000 SERIES TRAINS

5.3 Magnetic Field Characteristics

The magnetic field at wayside locations includes contributions from natural sources (the geomagnetic field), the Metrorail System, and other man-made sources (primarily the power distribution system). The extent to which these sources contribute to the total field at the wayside is examined separately for the two measurement locations.

5.3.1 At Underpass

Figure 5-3 is the three dimensional field plot from dataset MET054 for the 110 cm height probe. The plot shows the rms magnetic flux density in mG versus frequency in Hz and also versus time, in seconds. The upper curve exhibits the static component and the lower plot suppresses it. The 60 Hz component and its odd harmonics are clearly distinguishable for the entire time period. There are also even harmonics present that have a temporal variation substantially different from the odd harmonics. Incidentally, the same 60 Hz component and its odd and even harmonics appear in the plots of dataset

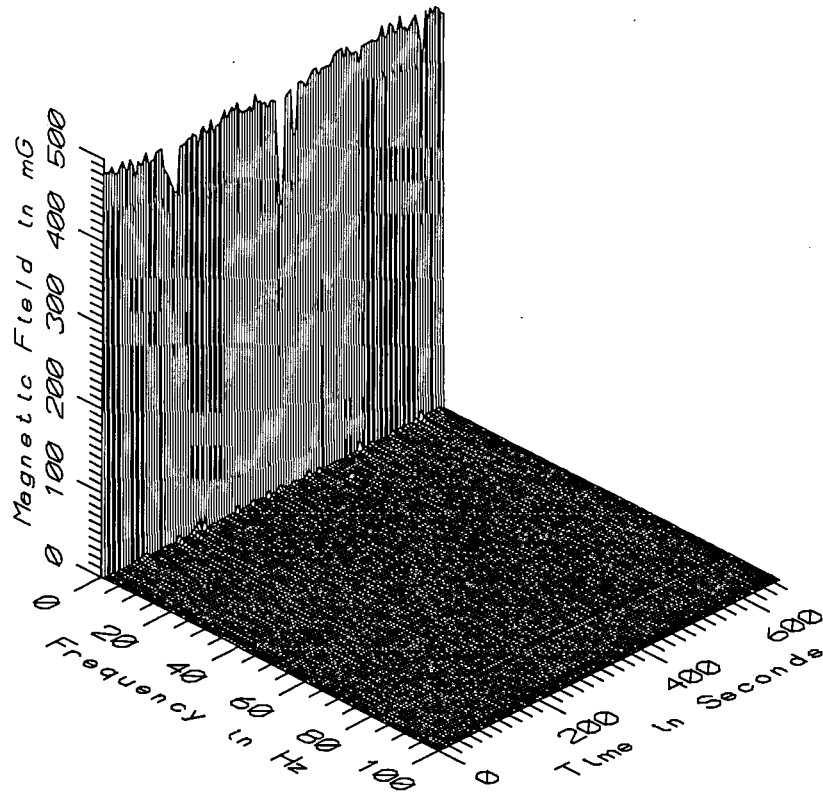

MET054 - 110cm ABOVE GROUND, BENEATH METRORAIL IN UNDERPASS

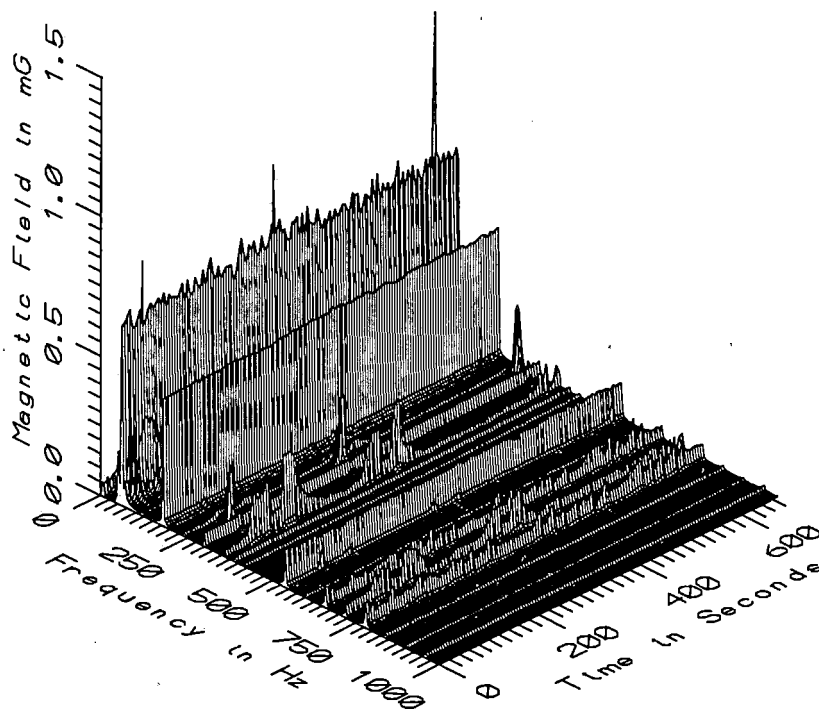

MET054 - 110cm ABOVE GROUND, BENEATH METRORAIL IN UNDERPASS

Figure 5-3 Magnetic field level, with and without the static component, at 110 cm height above ground at the underpass as a function of frequency and time.

MET055 (see Appendix AY), and are of approximately the same magnitude. These plots indicate that there are two principal sources of time varying magnetic field. Current in the third rail, tracks, and feeder cables (if present) of the Metrorail System give rise to time varying field components primarily at rectifier ripple frequencies, 120, 240, 360, 660, 720, and 780 Hz. These are clearly visible in the lower frame of Figure 5-3 and can be seen to vary in amplitude over time as the trains operating on the overhead system draw varying amounts of power. The second apparent field source is current in the nearby commercial electric power distribution system. Magnetic fields from power systems are predominantly 60 Hz and the odd harmonics of 60 Hz. Magnetic field components at 60 Hz and the odd harmonic frequencies of 180 Hz, 300 Hz, and 540 Hz are evident in Figure 5-3 and seen to have no temporal variability correlating with Metrorail operations.

The 60 Hz magnetic field component shows a weak attenuation pattern with increased height above the sidewalk suggesting that it and the other odd harmonic components come from a source beneath and to the side of the measurement staff. The source is possibly a three-phase distribution cable buried beneath the street. The attenuation pattern of the ripple frequency components of the magnetic field, which are apparently due to the Metrorail System, is difficult to evaluate because of the presence of larger field components from the presumed distribution line source. But, in the vertical profile curves for the power harmonic and high frequency bands of Appendix AX, there is an indication of increased field strength at the higher measurement locations at those time points when the ripple frequency components are the largest. That observation is consistent with the conclusion that those components of the magnetic field are produced by current in the overhead third rails and tracks.

The static field at this measurement location is primarily the natural geomagnetic field of the earth, nominally 500 mG in the Washington area. The top frame of Figure 5-3 shows a small perturbation in the total static field as the train passes. This perturbation is shown to follow the precise pattern in all height positions. This superimposed variation on the earth's magnetic field is probably due to both the current in the rails and the large ferromagnetic material mass (the train) passing overhead.

These observations and the field plots indicate that the main source of static magnetic field beneath the Metrorail overpass is the earth's magnetism. Small perturbations to the natural static field level occur due to the presence of the train overhead and also due to static magnetic fields created by dc current in the third rail, tracks, and possibly supply cables (if present at this location). The main source of the ac

field appears to be the nearby commercial electric power distribution system, but minor contributions from current in the third rail, track, and possibly feeder cables are detectable at the rectifier ripple frequencies.

5.3.2 At An Open Space

Figure 5-4 is the three dimensional plot of the magnetic field versus frequency and time for dataset MET056 at the probe location 10 cm outside the Metrorail right-of-way fence. The most prominent frequencies present are the 60 Hz component and its third (180 Hz) and ninth (540 Hz) harmonics. These three frequencies are in the same ratio to each other for all staff probe locations. There are also even harmonics which are part of the rectification process of the Metrorail power supply. The two sets of temporal variations (fundamental and odd harmonics versus even harmonics) are not identical, indicating the possibility that there are two sources: the rail currents that contain even harmonics from the rectification process; and a nearby electric power circuit. The portion of the total time varying field apparently attributable to a power line is at least an order of magnitude larger than the portion attributable to ripple currents in the Metrorail System. The presence of large third and ninth harmonics indicate that the nearby electric power circuit is a well balanced three-phase circuit, possibly a subtransmission line or circuit feeding the traction power station just north of this location. The 720 Hz frequency is the highest distinguishable harmonic frequency in the figure. It is the 12th harmonic, a component which often results from the rectification process. The low frequency and high frequency magnetic field bands exhibit a slight attenuation with increasing distance from the tracks over the short 1.5 meter distance of the staff, as shown in the horizontal profile graphs of Appendix AZ. The other frequency bands which are heavily dominated by magnetic fields from the apparent power line source show virtually no attenuation over the length of the profile. The data does not show any 273 Hz chopper frequency attributable to the 3000 series cars passing by.

The static field measurements at this location are similar to those at the highway underpass in that the principal field source is the earth's magnetism. The small temporal variability in the static field shown in the upper frame of Figure 7-4 is apparently due to a fluctuating static field produced by current in the third rail and tracks. The static field, caused by current in the traction power circuits, varies over time due to trains entering and exiting the traction power block and the fluctuating power needs of trains within the block. Hence, it is distinguishable from the geomagnetic field which is essentially constant over time. Since the fluctuating component of the static field seen in

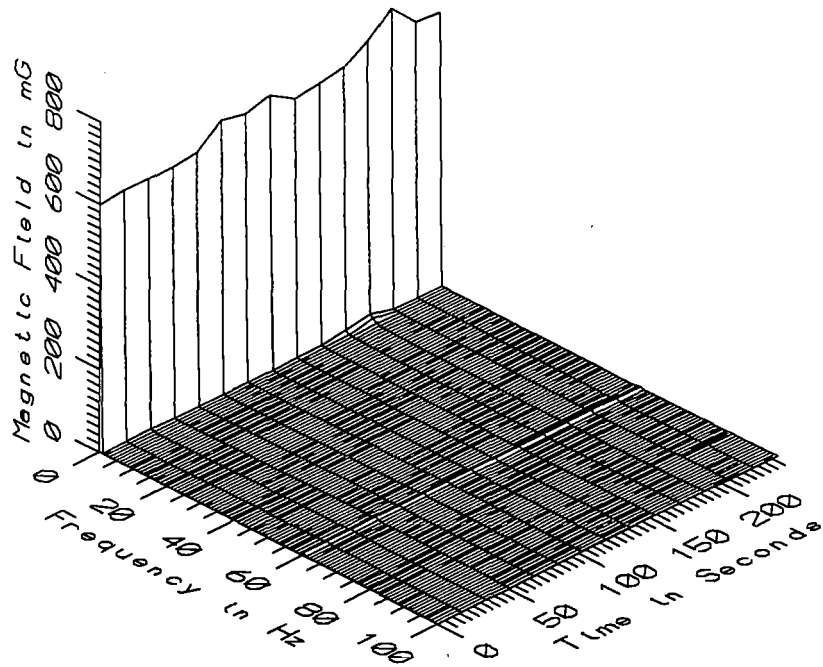

MET056 - 10cm FROM FENCE, WAYSIDE MEASUREMENT, 1M ABOVE GROUND

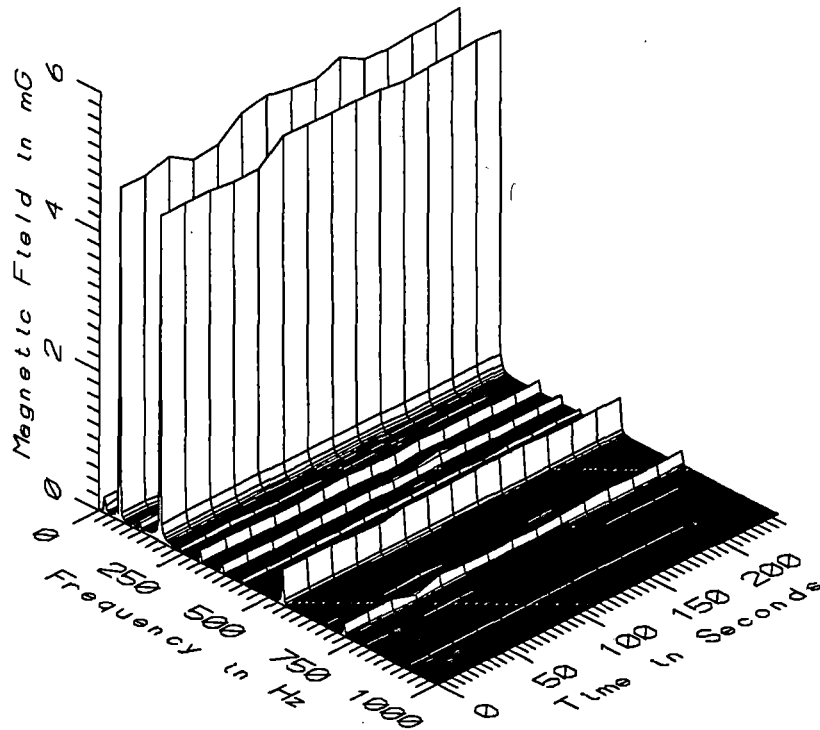

MET056 - 10cm FROM FENCE, WAYSIDE MEASUREMENT, 1M ABOVE GROUND

Figure 5-4 Magnetic field level, with and without the static component, at 10 cm distance from the fence at the wayside, south of Shady Grove, as a function of frequency and time.

the upper frame of Figure 5-4 is only a small portion of the overall static field, one would conclude that the static field produced by the Metrorail System is rather small compared to the geomagnetic field. However, the average static field measured 10 cm from the fence at this location is approximately 100 mG higher than the expected geomagnetic field for the Washington, DC vicinity. That increase in average static field does not appear attributable to static magnetic fields from the Metrorail System but is more likely due to local perturbation of the geomagnetic field by the steel fence or reinforcing steel in the concrete retaining wall beneath the fence. The return of the average static field level to the expected 500 mG level at sensor locations a meter or more from the fence seems to support this conclusion.

5.4 DAT Waveform Data

Magnetic field data from the reference probe of the *MultiWave*™ System was recorded continuously with a digital audio tape recorder as described in Section 2.5 at the highway underpass location. This recording is identified as Tape 2, Record 4 in Table 2-2. The static field recording showed the same temporal pattern as the repetitive waveform data of Figure 5-3 when the train passed overhead. The analysis of total rms time varying magnetic field in the DAT recording provided no useful information about time varying fields from the Metrorail System because background time varying field from apparent power systems sources obscured the weaker fields from the Metrorail System.

DAT recordings were not made at the open space location at the wayside.

5.5 Summary of Magnetic Field Levels

Appendices AX and AY contain the figures of the magnetic field plots for the highway underpass at Rockville. Appendix AZ contains the figures of the magnetic field plots for the open space along the track between Silver Spring and Rockville. The main sources of magnetic fields at these locations were apparently the nearby commercial electric power lines and the geomagnetic field of the earth. The Metrorail line produced detectable static and time varying magnetic fields but they were typically at least three times smaller and often ten times smaller than the fields which existed from other sources.

Table 5-2 summarizes the statistics of the vertical measurements beneath the Metrorail at the highway underpass. This table, like the others, shows the minimum, maximum and average field levels, as well as standard deviation and coefficient of variation. The results are summarized by the set of five frequency ranges

TABLE 5-2

STATISTICAL SUMMARY OF THE MAGNETIC FIELD LEVEL AT VARIOUS HEIGHTS ABOVE THE ROAD SURFACE BENEATH THE METRORAIL AT THE HIGHWAY UNDERPASS AT ROCKVILLE (DATASETS MET054 AND MET055)

MET054, 55 - BENEATH METRORAIL AT HIGHWAY UNDERPASS		TOTAL OF 139 SAMPLES				
FREQUENCY BAND	HEIGHT ABOVE FLOOR (cm)	MINIMUM MAGNETIC FIELD (mG)	MAXIMUM MAGNETIC FIELD (mG)	AVERAGE MAGNETIC FIELD (mG)	STANDARD DEVIATION (mG)	COEFFICIENT OF VARIATION (%)
STATIC	10	383.81	549.51	496.59	19.71	3.97
	60	353.78	548.08	486.09	22.93	4.72
	110	339.19	540.35	474.05	24.54	5.18
	160	335.90	565.60	484.50	27.81	5.74
5-45Hz LOW FREQ	10	0.19	1.19	0.31	0.14	46.26
	60	0.15	1.15	0.25	0.15	63.00
	110	0.04	1.24	0.16	0.18	113.73
	160	0.17	1.52	0.28	0.19	69.72
50-60Hz PWR FREQ	10	0.70	0.80	0.75	0.02	2.44
	60	0.66	0.83	0.74	0.04	5.02
	110	0.63	0.77	0.69	0.03	4.25
	160	0.60	0.71	0.65	0.02	3.12
65-300Hz PWR HARM	10	0.42	0.59	0.44	0.03	5.97
	60	0.46	0.64	0.49	0.03	5.64
	110	0.48	0.67	0.53	0.03	6.47
	160	0.56	0.77	0.60	0.03	5.46
305-2560Hz HIGH FREQ	10	0.17	0.36	0.22	0.04	18.74
	60	0.17	0.38	0.23	0.05	20.80
	110	0.16	0.38	0.22	0.05	22.53
	160	0.17	0.44	0.24	0.06	26.59
5-2560Hz ALL FREQ	10	0.89	1.52	0.96	0.08	8.60
	60	0.86	1.48	0.96	0.09	9.16
	110	0.83	1.54	0.93	0.10	10.37
	160	0.88	1.78	0.97	0.12	12.75

discussed in Section 2.4, Figure 2-1 and are used throughout this report. The maximum time varying field reading of 1.52 mG occurred in the low frequency range, at the 160 cm probe level. This is not surprising since the low harmonics reflect the static field perturbations as the cars travel over the underpass where the 160 cm probe is the nearest to the tracks. The magnetic field levels reported in the static band are dominated by the earth's field while values reported in the other time varying bands are dominated by background field levels from nearby power lines. The fields from the Metrorail System are considerably less than the background levels tabulated for those bands.

Table 5-3 summarizes the statistics of the horizontal measurements along the wayside, south of Shady Grove. The maximum reading of 5.36 mG occurred in the power frequency range at the probe 60 cm from the right-of-way fence. This field is believed to originate from a nearby power line for the reasons described above. This conclusion is further supported by the very low standard deviation, on the order of 0.1 mG, for the power frequency and the harmonic ranges indicating little variation during the recording even though two trains passed the measurement point. The time varying magnetic field levels produced by the Metrorail System are considerably smaller than the background levels from other sources reported in Table 5-3.

Reliable empirical estimates of the attenuation rate of magnetic fields away from the Metrorail System cannot be made from the available data because the weak fields from the transportation system are obscured by background fields from other sources.

5.6 Summary of Electric Field Levels

Time varying electric field levels were measured at both locations, the underpass and the wayside. The electric field was measured at 1.70 meters above ground at the highway underpass near the Rockville Station. The field measured less than 1 V/m. Appendix AX contains the plot of the results. The electric field was measured at 1 meter above ground, approximately 1.7 meters from the fence, at an open space along the tracks between Shady Grove and Rockville. Figure 5-5 shows the results of this measurement in V/m plotted versus frequency in Hz and time in seconds. It can be seen that the electric field is less than 5 V/m and mainly 60 Hz. This indicates that the electric field results from a nearby distribution line.

TABLE 5-3

STATISTICAL SUMMARY OF THE MAGNETIC FIELD LEVEL AT VARIOUS
DISTANCES FROM THE TRAIN TRACK FENCE, ALONG THE WAYSIDE SOUTH OF
SHADY GROVE (DATASET MET056)

MET056 - WAYSIDE SOUTH OF SHADY GROVE		TOTAL OF 15 SAMPLES				
FREQUENCY BAND	DIST FROM FENCE (cm)	MINIMUM MAGNETIC FIELD (mG)	MAXIMUM MAGNETIC FIELD (mG)	AVERAGE MAGNETIC FIELD (mG)	STANDARD DEVIATION (mG)	COEFFICIENT OF VARIATION (%)
STATIC	10	597.88	733.42	645.14	37.30	5.78
	60	535.13	618.28	556.34	21.25	3.82
	110	499.94	575.45	519.16	18.87	3.63
	160	490.08	560.47	514.22	16.44	3.20
5-45Hz LOW FREQ	10	0.22	1.00	0.48	0.28	58.73
	60	0.19	0.89	0.40	0.25	61.57
	110	0.11	0.87	0.36	0.26	74.35
	160	0.20	1.10	0.43	0.27	62.11
50-60Hz PWR FREQ	10	4.67	5.10	4.90	0.12	2.55
	60	4.99	5.36	5.17	0.11	2.21
	110	4.87	5.21	5.06	0.09	1.72
	160	4.86	5.11	4.99	0.08	1.51
65-300Hz PWR HARM	10	4.68	5.00	4.88	0.13	2.67
	60	4.86	5.10	5.00	0.10	1.92
	110	4.69	4.88	4.80	0.07	1.37
	160	4.48	4.64	4.57	0.05	1.10
305-2560Hz HIGH FREQ	10	0.55	0.67	0.63	0.03	4.84
	60	0.57	0.65	0.61	0.02	3.83
	110	0.54	0.61	0.59	0.02	3.58
	160	0.52	0.59	0.56	0.02	3.29
5-2560Hz ALL FREQ	10	6.64	7.21	6.96	0.18	2.62
	60	7.00	7.45	7.24	0.14	1.99
	110	6.79	7.16	7.02	0.10	1.44
	160	6.65	6.94	6.80	0.09	1.32

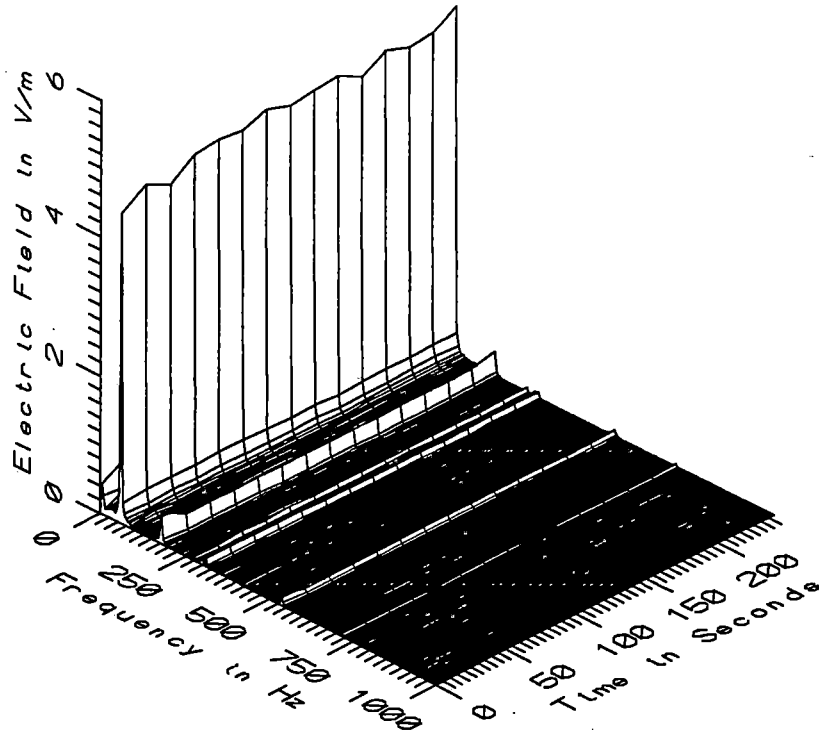

MET056 - ELECTRIC FIELD AT WAYSIDE SOUTH OF SHADY GROVE

Figure 5-5

Electric time varying field level 1.0 meter above ground, at 20 feet distance from the fence at the wayside, south of Shady Grove, as a function of frequency and time.

6.0 PASSENGER STATION MEASUREMENTS

Platform readings were taken at two locations: the outdoor platform at Grosvenor passenger station on the Red Line and the underground Gallery Station. The latter is a transfer station between the Red and the Green/Yellow Lines. It is in two levels. The lower is the Green/Yellow Line platform and the upper connects via a mezzanine over the lower platform to the Red Line platform.

6.1 Measurement Locations

Figure 6-1 shows the schematic layout of the platform at Grosvenor. Measurements were taken on both northbound and southbound sides of the platform near the edge. Some were taken at the end of the platform in order to record fields for trains leaving from and arriving at the station. Other readings were taken in the middle of the platform, in front of the escalator and while riding the escalator up and down. Many of these readings were taken with the sensor staff in both the vertical and horizontal-transverse positions. Datasets MET015 through MET025 were recorded on this platform on May 19, 1992 from 10:56 to 11:31 hours.

Figure 6-2 shows the schematic layout of the Gallery transfer station platform and mezzanine. The platform for the Green/Yellow Line is on the lower level. On the upper level, a mezzanine provides access to the Red Line. Three sets of escalators connect the two levels as well as providing access from the opposite side of the Red Line. The Red Line tracks are in the middle with the passenger access platforms on the outside, whereas the Green/Yellow Lines have the tracks on the outside of the center platform. Measurements were taken on both the northbound and southbound sides of the Green/Yellow Line platform near its south end. Both vertical and horizontal profiles were measured and recorded in datasets MET031 through MET034. Readings were also taken on the upper mezzanine level, over the northbound tracks, to quantify the magnetic field environment above a passing Metrorail train. Two vertical profiles were recorded at 100 and 50 feet from the Red Line tracks. These datasets are MET035 and MET037, respectively. The recordings in this underground transfer station were taken on May 19, 1992 from 15:49 to 16:13 hours.

The staff with the four probes, when set in a vertical position, was usually placed at the inside edge of the granite sill which forms the edge of the platform. That position, which is approximately 15 inches from the edge of the platform, was chosen because it represents an easily identifiable position as near the edge of the platform as a passenger could safely and reasonably stand while waiting for a train. The reference probe was also set on the inside edge of the granite sill but at a position approximately 25 to 30 feet from the staff in the direction of the end of the platform. When the staff was horizontal, it was held one meter above the platform and perpendicular to the tracks.

6-2

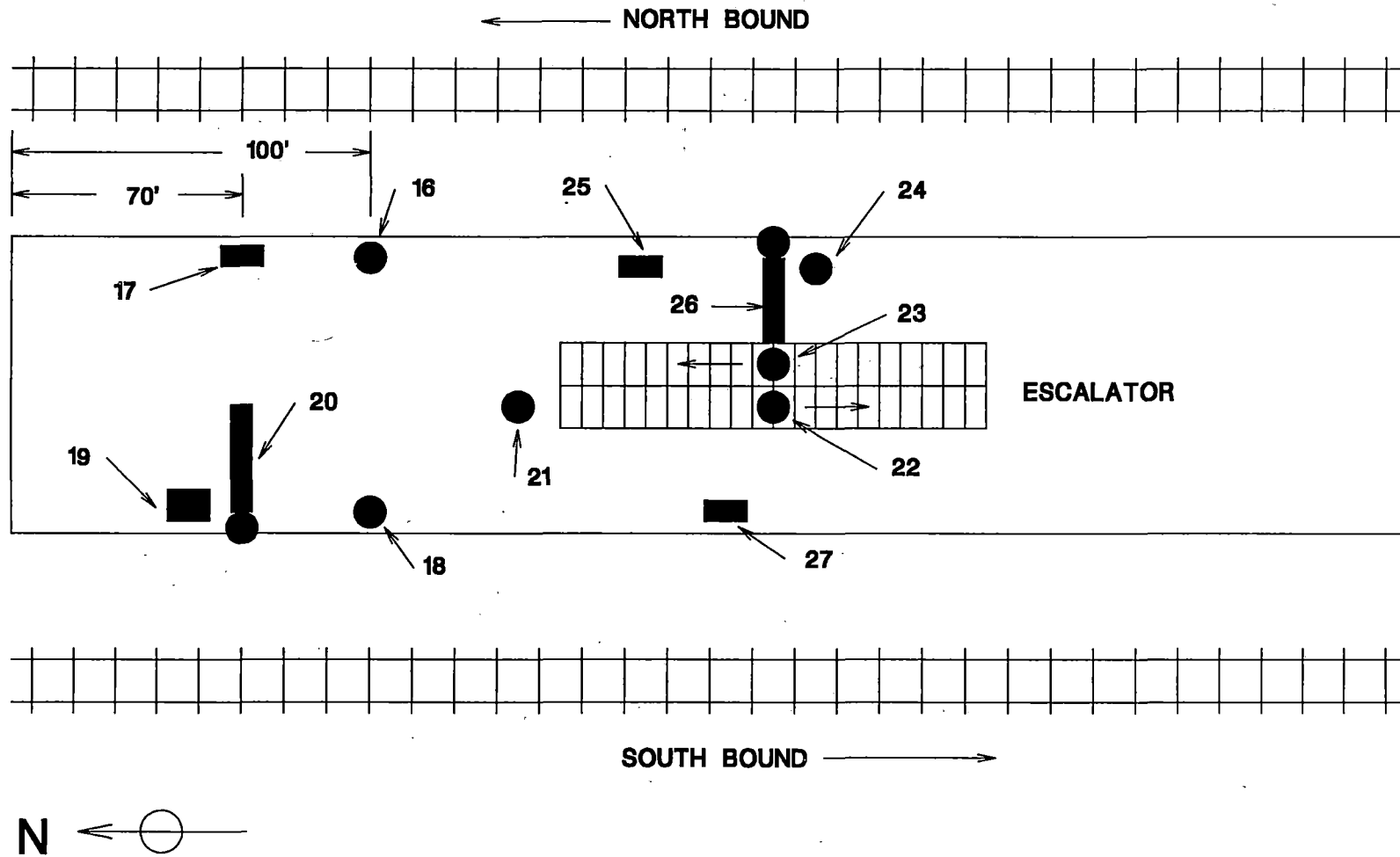

PLATFORM AT GROSVENOR

Figure 6-1 Repetitive waveform measurement locations on the passenger platform at Grosvenor.

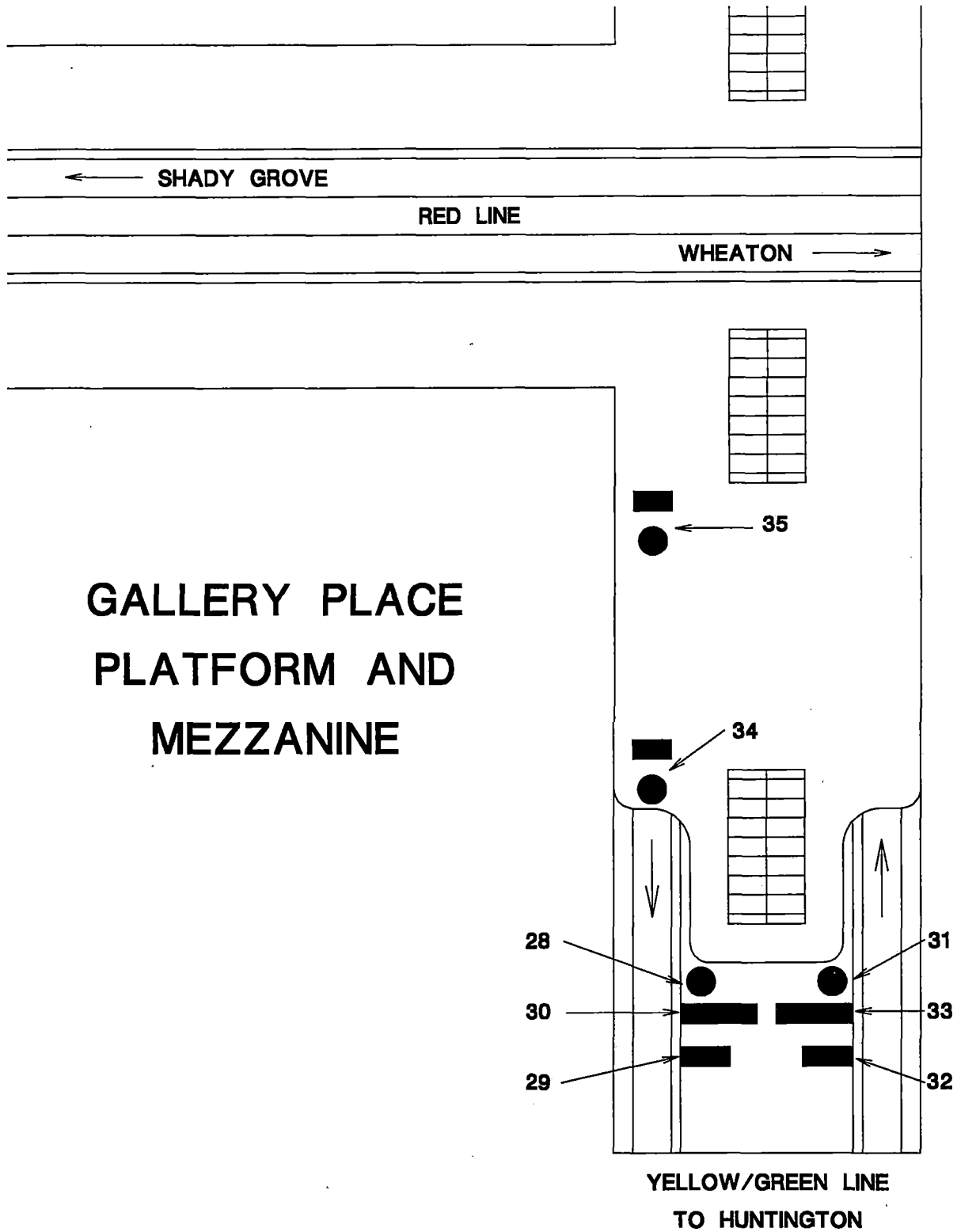

Figure 6-2

Repetitive waveform measurement locations at the Gallery passenger transfer station platform and mezzanine.

Unless indicated otherwise, the reference probe was placed on the opposite side of the platform at the inside edge of the granite sill during horizontal profile measurements.

Data was also collected using the DAT and EMDEX-II instruments. DAT recordings were made from the sensor in the reference probe, whose locations have already been described. The EMDEX-II recorders were worn by two members of the measurement team. While their exact locations during the recordings are not known, they were in the general area where the other measurements were in progress.

6.2 Repetitive Waveform Datasets

Eight datasets were recorded at the Grosvenor passenger station (MET015 through MET025) and six datasets were recorded at the Gallery Place transfer station (MET031 through MET037). Table 2-1 summarizes the pertinent information contained in these fourteen datasets, including the appendix where the corresponding data are located, the number of samples and the location of probes. The appendices contain figures that are three dimensional plots of magnetic field versus frequency over time and horizontal or vertical profile plots of field versus distance over time.

6.3 Magnetic Field Characteristics

The measurements discussed in this section of the report were intended to characterize the magnetic fields that a passenger might encounter at a station. Consequently, many measurements were made near the edge of the platform where the magnetic field from passing trains or from current in the third rail and tracks would likely be the largest. Additional measurements were made near the center of the platform and on the escalators in order to characterize magnetic fields from sources such as lighting and station electrical equipment, e.g., escalator motors. Finally, the measurements on the mezzanine of the Gallery Place Station above the Green/Yellow Line tracks are examined to characterize field levels above Metrorail trains such as those that might be encountered in stations or at highway and pedestrian overpasses.

Figures 6-3 and 6-4 are plots of the rms magnetic flux density in mG versus frequency in Hz and time in seconds measured 10 cm and 160 cm above the floor at the edge of the Grosvenor platform. These are part of dataset MET017 contained in Appendix P. These measurements are part of a vertical profile measurement taken at the north end of the station platform at the edge of the granite sill along the southbound track. The measurement location is identified as position 18 on Figure 6-1. This location was selected because arriving southbound trains pass on the way into the station. A train of four 3000 series cars is just pulling into the station and passing the measurement sensors at the 5 second

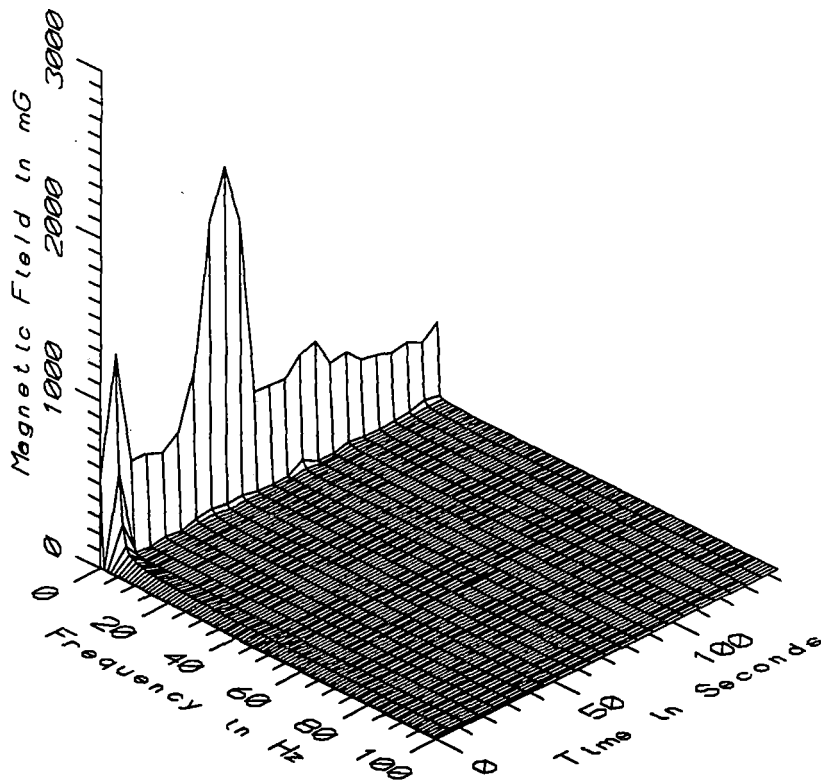

MET017 - 10cm ABOVE PLATFORM AT SAFETY LINE, ARRIVING END

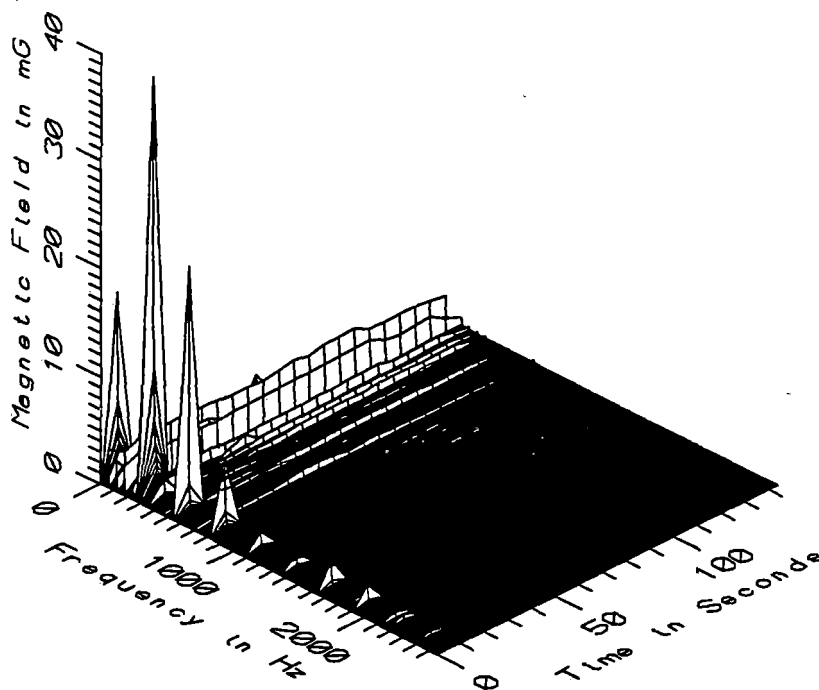

MET017 - 10cm ABOVE PLATFORM AT SAFETY LINE, ARRIVING END

Figure 6-3 Magnetic field 10 cm above the floor at the edge of the Grosvenor station platform as a train enters, stops, and departs. The static field is suppressed in the lower frame to show the time varying components.

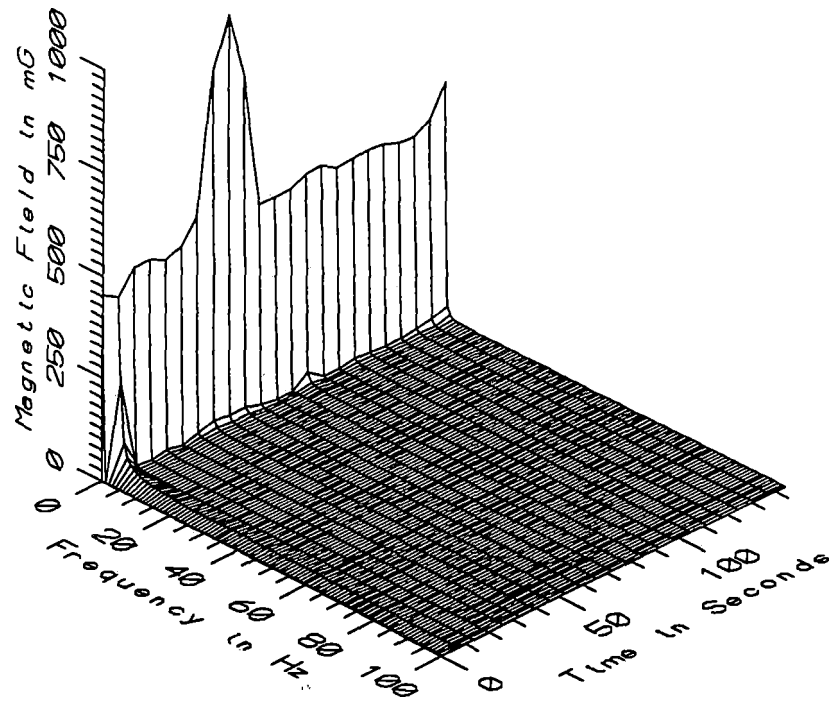

MET017 - 160cm ABOVE PLATFORM AT SAFETY LINE, ARRIVING END

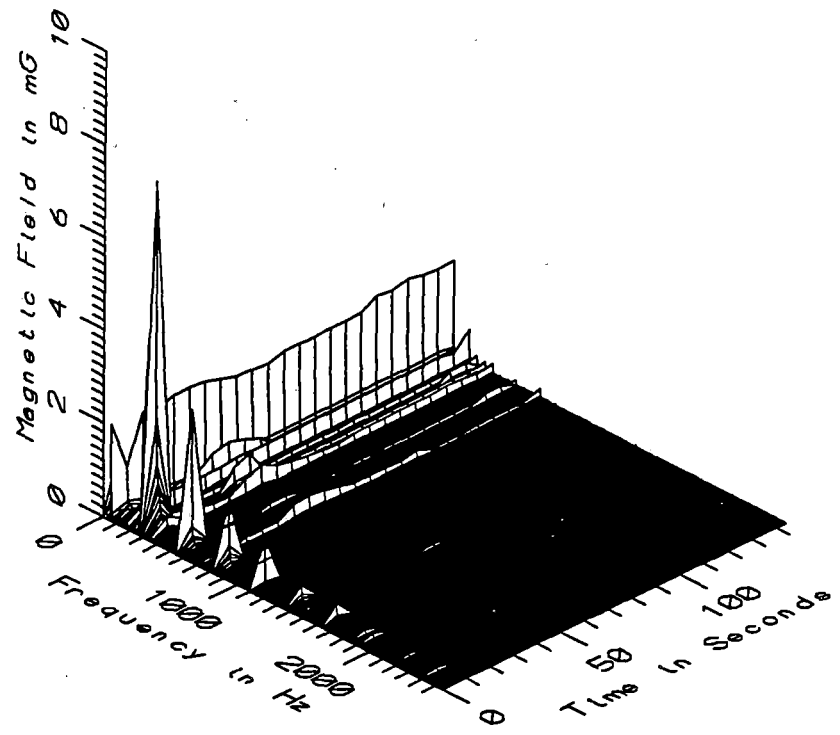

MET017 - 160cm ABOVE PLATFORM AT SAFETY LINE, ARRIVING END

Figure 6-4 Magnetic field 160 cm above the floor at the edge of the Grosvenor station platform as a train enters, stops, and departs. The static field is suppressed in the lower frame to show the time varying components.

sample point. After a brief station stop, the train starts moving again at the 40 second point.

Examination of the top frame of Figure 6-3 shows that the static field is elevated above the normal 500 mG ambient level as the train passes the sensors while entering the station and again as the train leaves the station. The top frame of Figure 6-4 shows a similar pattern except that the static field excursions from ambient levels are considerably smaller. The field attenuation with increased height confirms that the magnetic field source is below the platform level.

The repetitive waveform sampling technique of field characterization was not developed to reliably capture infrequent transient events such as passage of a train very close to the sensors. That is because those events can occur between the waveform samples which occur every 5 seconds. As described in Section 2.5 above, a continuous recording of the magnetic field was made with the digital audio tape (DAT) recorder at one location to "fill in" between repetitive waveform samples. Figure 6-5 shows a plot of total static magnetic field versus time for Record 7 of the first DAT tape (see Table 2-2 for pertinent information) which was recorded at the reference sensor location (Location #19 on Figure 6-1) at the edge of the platform. The portion of this record from approximately the 1 minute point to the 3.5 minute point was recorded concurrently with the repetitive waveform system and those data are in Figures 3-3 and 3-4. Since the reference sensor was only a few centimeters above the floor near the edge of the platform, the DAT data in Figure 6-5 are most comparable to the repetitive waveform data from the 10 cm high sensor contained in Figure 6-3 even though the two sensors are 25 to 30 feet apart along the edge of the platform. Comparison of the relevant portion of the continuous static field recording of Figure 6-5 to the static field recording in the top frame of Figure 6-3, which originated from successive 5 second samples, shows that in this case, the repetitive waveform samples captured the general time characteristic of the magnetic field but missed the fact that there were four discrete bursts of static field as the four 3000 series cars of the train passed the sensor while entering the station.

From the temporal and spatial characteristics of the static field and the position of the train over the time of the record, it appears that there are three principal sources of static magnetic field at the edge of the platform. The first is the earth's magnetism which produces the background level of nearly 500 mG. This is the dominant source when the train is away from the station or stopped at the station. Secondly, as the 3000 series cars pass, each produces a highly localized magnetic field, probably from the line smoothing reactor beneath the center of each car. These can be seen at the 5 second time point in Figure 6-3 and at the corresponding 1.2 minute time point in Figure 6-5. The third

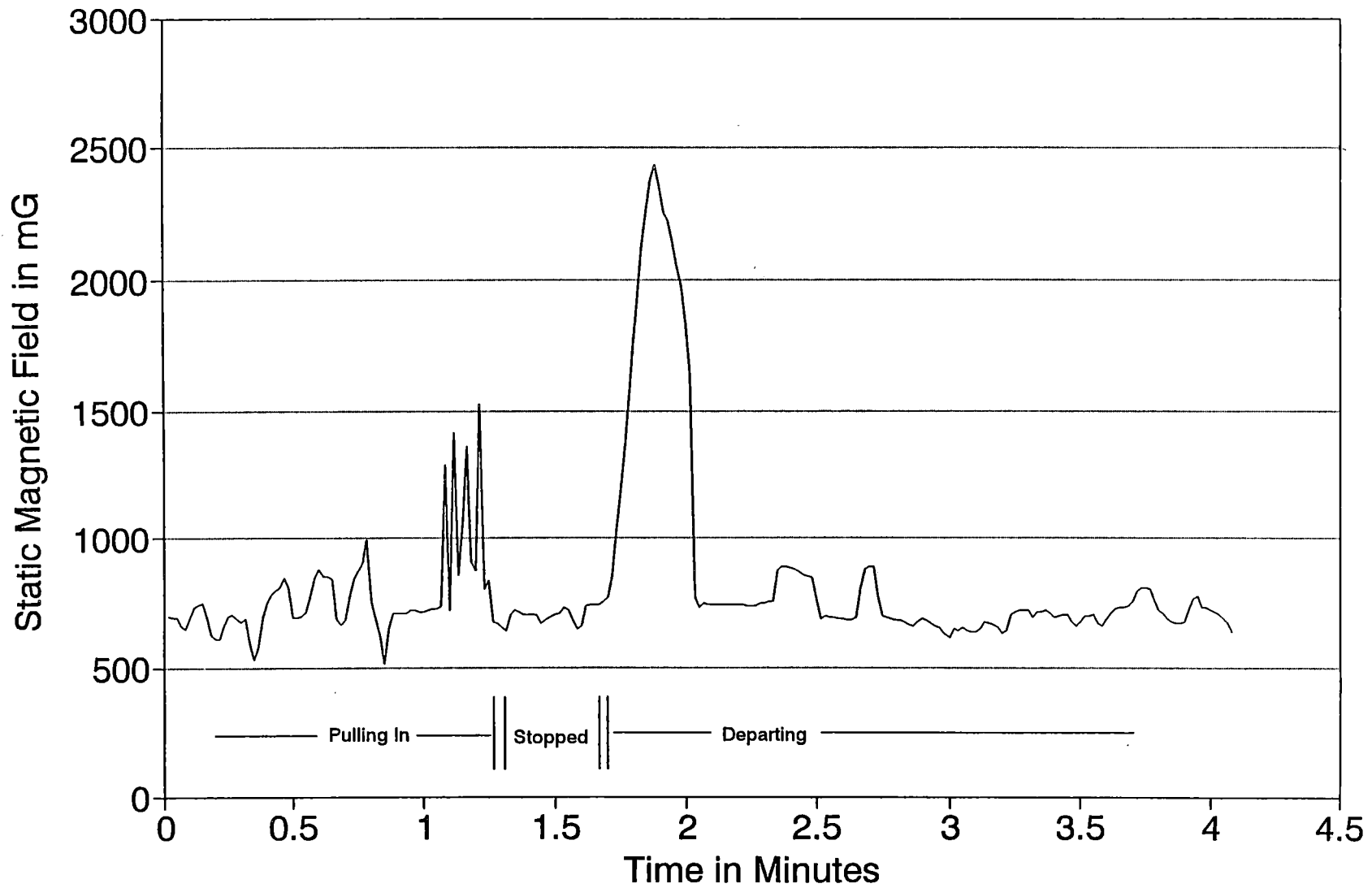

Figure 6-5 Continuous magnetic field recording at the edge of the Grosvenor station platform at the arriving end as a train enters, stops, and departs.

source is the dc current in the third rail and track return circuit which produces static fields with less spatial variability, but which are temporally correlated with train activities such as acceleration which require considerable electric current. An example of that condition is at the 50 second time point of Figure 6-3 or the corresponding 1.9 minute time point of Figure 6-5 when the train was accelerating out of the station.

The bottom frames of Figures 6-3 and 6-4 show the time varying components of the magnetic field at the edge of the platform. When the arriving train passes the sensor at the 5 second sample point, time varying fields at the train's chopper frequency (273 Hz) and harmonics thereof dominate the spectrum. However, those fields rapidly disappear as the train moves past the sensor. Low frequency components resulting from the rapidly changing static field level of the passing train can also be seen at the 5 second sample point. Comparison of the time varying field levels produced by the passing train at the 10 cm measurement height (Figure 6-3) and at the 160 cm height (Figure 6-4) shows an attenuation of at least eight fold with increasing measurement height. The frequency characteristics of the field at the 5 second point as well as the rapid attenuation rate suggest that the short duration bursts of magnetic field seen as the train passes the sensor arise from the smoothing reactor at the center of each 3000 series car.

The plots of time varying magnetic field in the lower frames of Figures 6-3 and 6-4 also reveal the presence of magnetic field components at 60 Hz and harmonics thereof. The 60 Hz component of the field appear to originate from electric power cables within or beneath the station platform because of the frequency, the lack of temporal correlation with the activity of Metrorail trains, and the attenuation with increased height above the platform. The third harmonic component, which frequently arises from 60 Hz electric power circuits, appears temporally correlated with the 60 Hz field, but has a much stronger vertical attenuation pattern than the 60 Hz field. That observation suggests that there are multiple electric power circuits around the measurement location which contribute to the magnetic field levels at 60 Hz and its odd harmonics. The magnetic field components at even harmonics of 60 Hz, especially at 120 Hz, 240 Hz, 360 Hz, and 720 Hz, are temporally correlated with the static field (and therefore third rail and track current). These are typical ripple frequencies from the rectification process, and show a strong attenuation with increased height indicating that they arise from ripple current in the third rail and track return circuit.

Measurements at other places along the edge of the Grosvenor Station platform identified in Figure 6-3 (repetitive waveform datasets MET015, MET018, MET022, MET024, and MET025 and DAT Records 6, 7, 8, and 9 of Tape 1) showed the magnetic field characteristics just described but in different sequence, depending on the position. For example, Figure 6-6 (DAT Record 6 of Tape 1) shows

6-10

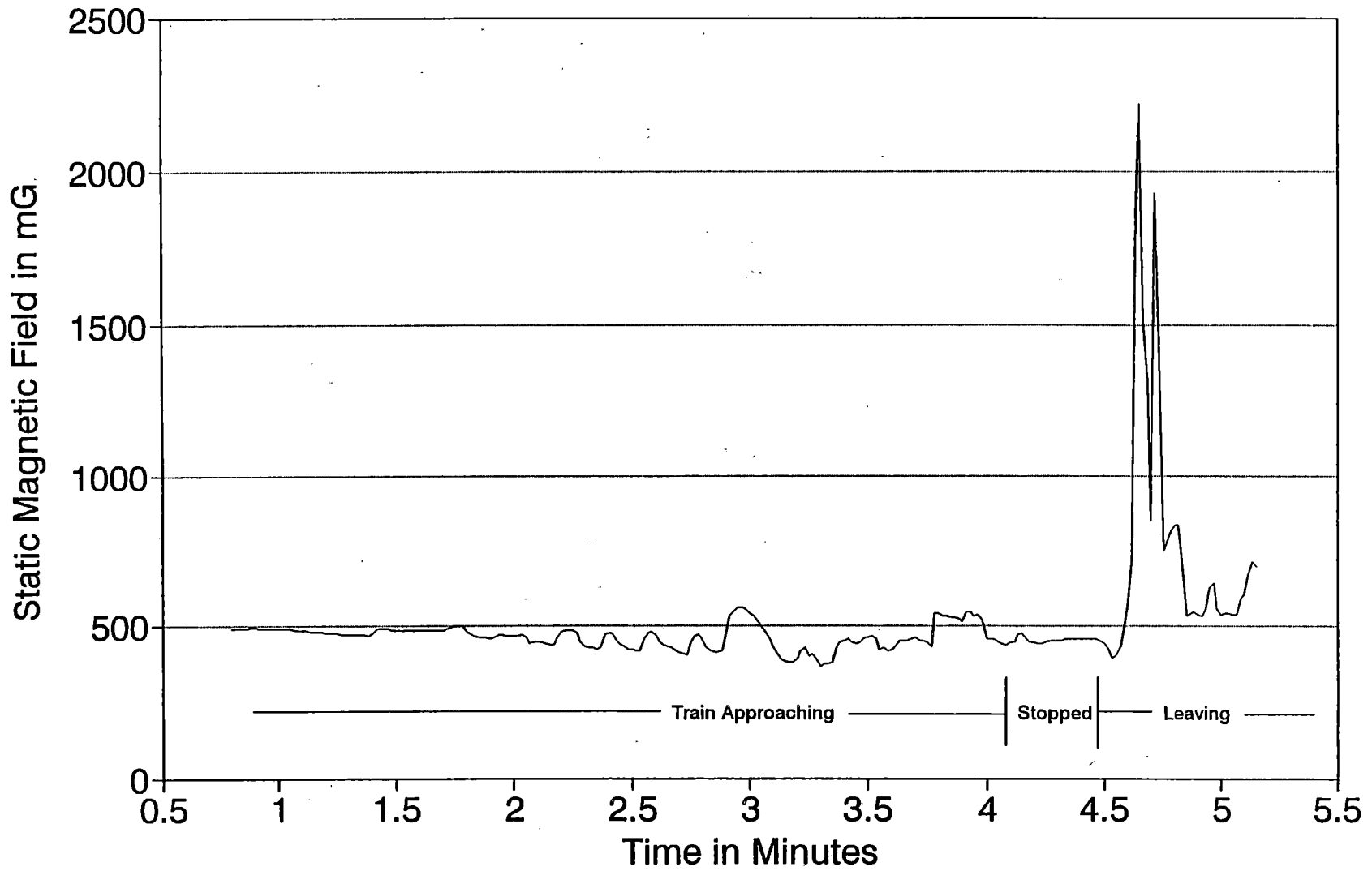

Figure 6-6 Continuous magnetic field recording at the edge of the Grosvenor station platform at the departing end as a train enters, stops, and departs.

the continuous recording of total field near the edge of the platform at the departing end (Location 17 on Figure 6-1). Since the train passes the measurement staff while departing the station, the short bursts of high field which occur when the cars pass the sensor are superimposed on the more general increase in static field resulting from elevated dc current in the third rail and track. However, if measurements are taken in the middle of the platform (Location 25 on Figure 6-1), a temporal field pattern as shown in Figure 6-7 (DAT Record 8, Tape 1) occurs. In this case, three of the 3000 series cars passed as the train was stopping and the fourth passed as the train started moving again.

Similar magnetic field measurements were made on the Green/Yellow Line platform at the Gallery Place Station (Locations 28 through 33 on Figure 6-1, repetitive waveform datasets MET031 through MET034, and DAT Records 12 to 14 of Tape 1). The magnetic field characteristics at the edge of the Gallery Place Station were similar to those described above for the Grosvenor Station with the following exceptions:

- * The background static field level varied from about 500 mG on one side of the Gallery Place platform to about 900 mG on the other. The background field level on the mezzanine was typically about 700 mG. The reason for these deviations from the normal geomagnetic field level of approximately 500 mG can not be determined with certainty from these data but could result from perturbation of the geomagnetic field by steel in the tunnel casings, platforms, and other underground station structures. Balanced traction current in the third rail and track return circuit is not usually an effective field generating source, because much of the field produced by current in the third rail is cancelled by the equal current flowing the opposite direction in the nearby tracks. However, in a transfer station such as Gallery Place, there may be multiple paths for the traction return current thereby unbalancing the flow of current in the third rail and nearby tracks. If that were the case, unbalanced electric currents flowing in the large loops made up of rails of interconnecting lines could lead to the atypical background static field levels in the Gallery Place Station. It would also account for the temporal variability of the background static field levels seen at Gallery Place.

- * The short duration burst of static and 273 Hz (and harmonics thereof) magnetic field does not occur as trains of 2000 series cars pass. This observation supports the earlier conclusions that those fields originate only from 3000 series cars.

Additional tests (MET035, MET037, and DAT Records 14A, 15, and 16 of Tape 1) were conducted on the mezzanine at Gallery Place (Locations 34 and 35 on Figure 6-1) to characterize the magnetic

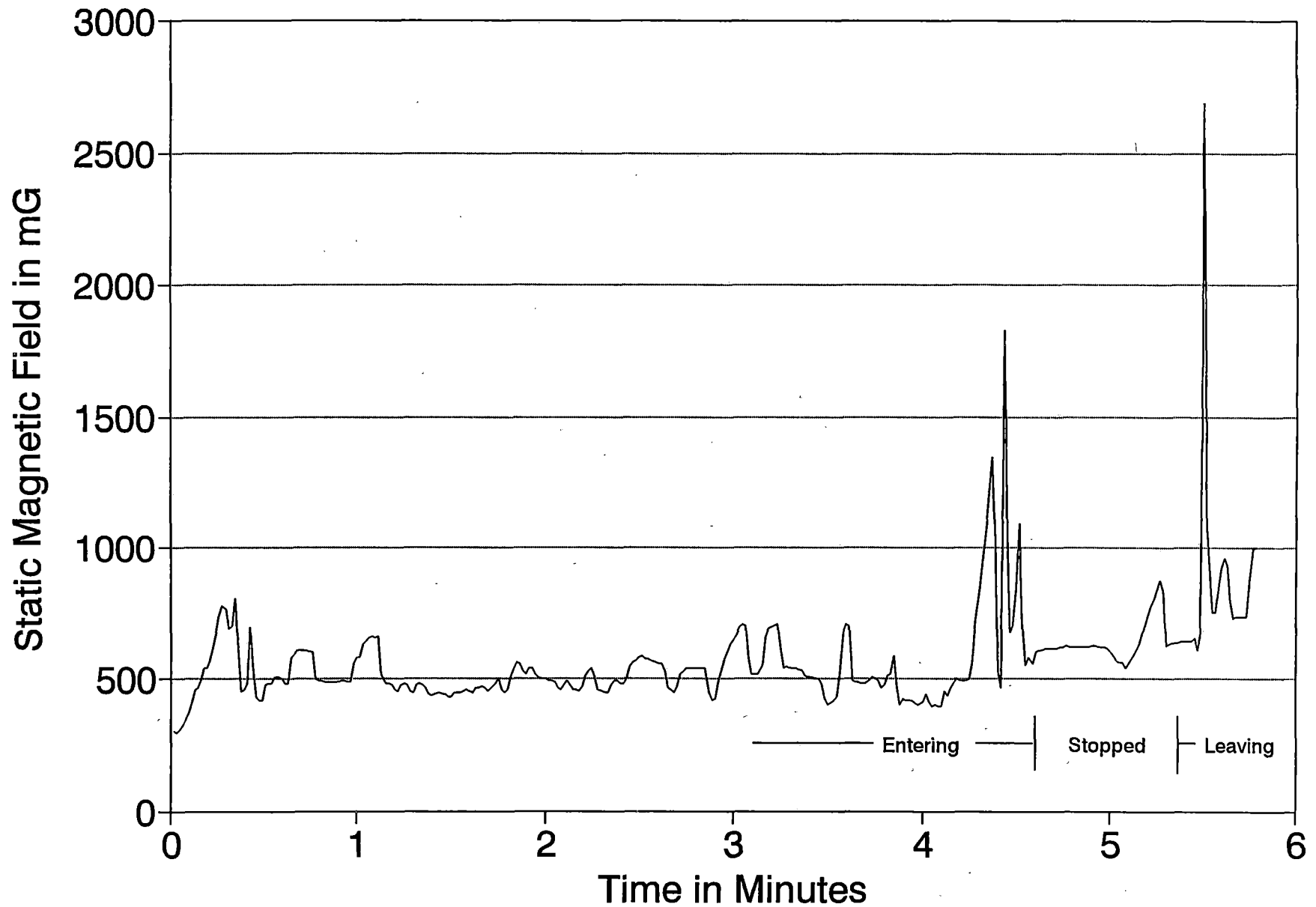

Figure 6-7 Continuous magnetic field recording at the edge of the Grosvenor station platform midway along the platform as a train enters, stops, and departs.

field above a passing train. Although there was some temporal variability in the static field at those locations and some components of the time varying magnetic field were present at the rectifier ripple frequencies, both of which are characteristics of fields from current in the third rail and track circuit, these field characteristics did not correlate in time with the passage of trains beneath the measurement point nor was there a reliable attenuation pattern suggesting that the fields originated from the train passing below (see Appendix AG).

Two additional measurements were conducted at the Grosvenor Station. One was to quantify the background field levels on the platform when no trains were in the area (dataset MET019, Appendix R) and the other was on the station escalator to quantify magnetic field levels near station equipment unrelated to the Metrorail vehicles (dataset MET021, Appendix S). The background field at the center of the platform consisted of the geomagnetic field of the earth and a time varying field of about 2 mG principally at 60 Hz. On the escalator, both the static and primarily 60 Hz time varying fields varied over time and position of the escalator apparently due to proximity to local sources such as the escalator motor and overhead lights.

In summary, the magnetic field data of the passenger platforms indicate temporal variations in both static and time varying field levels. The variability is due almost entirely to changing current in the third rail and track circuit depending on the power needs of the Metrorail cars. Both static and time varying fields are also produced for a short duration as trains, especially those made up of 3000 series cars, pass by. The fields from current in the rails and the passing trains have large spatial variability, especially at the edge of the platform. Moreover, there are background fields present from the earth's magnetism and from 60 Hz electric power circuits in and around the station.

6.4 DAT Waveform Data

Magnetic field data from the reference probe of the *MultiWave*™ System was recorded continuously with a DAT recorder, as described in Section 2.5. These measurements were made at various places along the edge of the platform at the Grosvenor and Gallery Place Stations as trains entered and departed the stations. The reference probe was placed on the platform floor at the inside edge of the granite sill which makes up the physical edge of the platform at the approximate locations designated with small rectangles in Figures 6-1 and 6-2. The continuous field recordings made at the platform edges are identified as Tape 1, Records 6 through 9 and 12 through 14 in Table 2-2. Pertinent data concerning the time and duration of these measurements and the key to the specific sensor location are found in that table.

Additional recordings (Records 14A, 15, and 16) were made at a few centimeters above the floor on the mezzanine at the Gallery Place Station. These recordings contain better detail of the temporal characteristics of the static fields than do the repetitive waveform data because there are no interruptions necessary to store the incoming data from the single sensor. These recordings were scanned for rapid transients then converted into total (resultant) magnetic field and plotted to show the fine temporal characteristics of the static field. Three of these time plots were presented in the preceding subsection (Figures 6-5 through 6-7).

Statistical summaries of static magnetic field levels measured by the DAT Recording System at the edge of the station platforms and on the station mezzanine are presented in Tables 6-1 and 6-2, respectively.

6.5 EMDEX-II Data

As stated previously, there are two major difficulties in analyzing and interpreting EMDEX-II data collected near the WMATA Metrorail System. First of all, researchers carrying the recorders neither follow a particular path nor keep an exact log of their location. In areas where there is a large spatial gradient in the field such as near the edge of the station platform, the field value recorded is highly dependent on the position of the wearer. The second difficulty arises because much of the time varying field near the dc-powered Metrorail System is in the low frequencies below the response band of the EMDEX recorders. However, the EMDEX recordings on the Grosvenor Station platform are appropriate because the 3000 series cars operating on the Red Line produce significant time varying magnetic fields within the frequency bandwidth of the EMDEX-II monitor. Figure 6-8 shows the time course records of the two EMDEX-II monitors for the time spent at the Grosvenor passenger station, namely 10:55 to 11:30 hours on May 19, 1992. This period spans the time of the recording of datasets MET015 through MET025. The two curves are fairly similar except at the times of the field peaks. That is because the general 60 Hz background field from normal electric power circuits in and around the station is relatively uniform over large areas of the station platform. However, when 3000 series trains pass by, higher levels of time varying fields are produced for short periods of time. These short duration fields produced by the Metrorail System account for the field "peaks" in the EMDEX recordings of Figure 6-7. The peaks of one curve usually match the peaks of the other in time but not in amplitude because the fields from the Metrorail System attenuate rapidly as one moves away from the platform edge. Therefore, field intensities recorded by the individual monitors during these peaks are highly dependent on the position of the EMDEX wearer. The data in the 11:24 to 11:25 time period on Figure 6-7 illustrate this point well.

TABLE 6-1

SUMMARY OF STATIC MAGNETIC FIELD LEVELS RECORDED
AT THE EDGE OF STATION PLATFORMS WITH THE DIGITAL
AUDIO TAPE RECORDER (DAT) AS TRAINS PASS

STATION/ LOCATION	MEASUREMENT LOCATION CODE		STATIC MAGNETIC FIELD MILLIGAUSS		
	(TAPE/REC.)	FIGURE #	LOCATION	MINIMUM	AVERAGE
GROSVENOR					
DEPARTING END (1/6)	6-1	17	366 mG	509 mG	2220 mG
ARRIVING END (1/7)	6-1	19	516 mG	823 mG	2434 mG
CENTER (1/8 & 9)	6-1	25,27	297 mG	754 mG	3271 mG
ALL (1/6 TO 9)	6-1	17,19,25, & 27	297 mG	1012 mG	3271 mG
GALLERY PL					
DEPARTING END (1/12 & 14)	6-2	29	558 mG	844 mG	2241 mG
ARRIVING END (1/13)	6-2	32	108 mG	1000 mG	2321 mG
ALL (1/12 - 14)	6-2	29 & 32	108 mG	918 mG	2321 mG
BOTH STATIONS					
ALL (1/6-9 & 12 - 14)	-	-	108 mG	796 mG	3271 mG

TABLE 6-2

**SUMMARY OF STATIC MAGNETIC FIELD LEVELS RECORDED
ON A STATION MEZZANINE WITH THE DIGITAL AUDIO TAPE
RECORDER (DAT) AS TRAINS PASS BELOW**

STATION/ LOCATION	MEASUREMENT LOCATION CODE		STATIC MAGNETIC FIELD MILLIGAUSS		
	(TAPE/REC.)	FIGURE #	LOCATION	MINIMUM	AVERAGE
GALLERY PL MEZZANINE					
SOUTH END (1/14A)	6-2	34	913 mG	1113 mG	1244 mG
CENTER (1/15 & 16)	6-2	35	676 mG	894 mG	952 mG
ALL (1/14A-16)	6-2	34 & 35	676 mG	938 mG	1244 mG

Table 6-3 shows the statistics for these EMDEX records at the Grosvenor Station. The average values are indicative of the background time varying field levels at the station from common 60 Hz electric power circuits unrelated to the transportation system. The maximum field values identify the maximum magnitude of the short bursts of time varying magnetic field produced by trains entering and leaving the station.

**TABLE 6-3
SUMMARY OF MAGNETIC FIELD LEVELS
RECORDED ON THE GROSVENOR PASSENGER PLATFORM
USING EMDEX-II DATA RECORDERS**

	AVERAGE	MAXIMUM
EMDEX #1	1.93 mG	8.3 mG
EMDEX #2	1.55 mG	10.6 mG
BOTH	1.67 mG	10.6 mG

GROSVENOR STATION PLATFORM

EmdexII Data From May 19, 1992

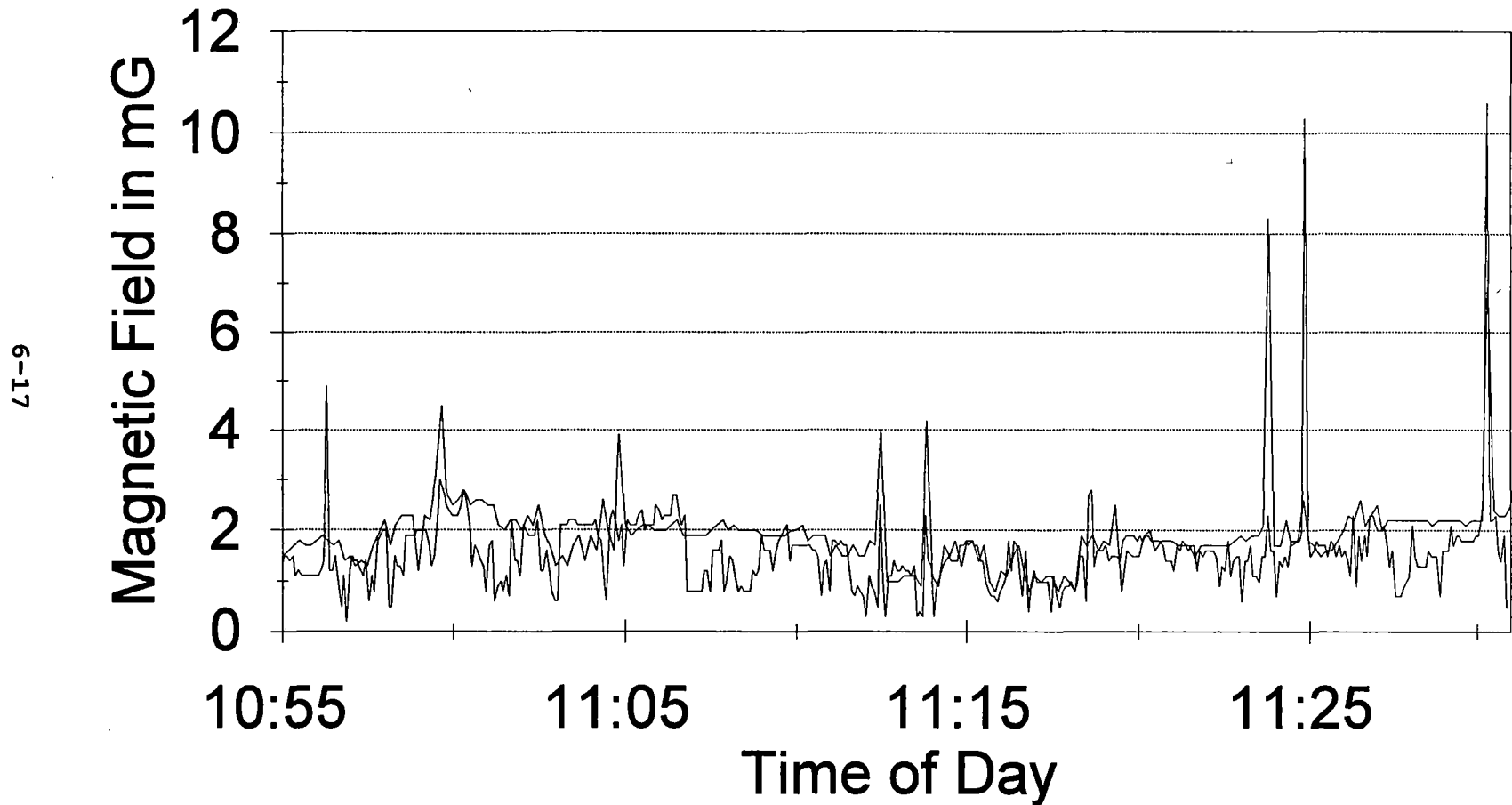

Figure 6-8

Magnetic field level recorded on the passenger platform at Grosvenor using the EMDEX-II recorders, as a function of time.

EMDEX data from the Gallery Place Station are not presented because they contain no useful data. The 2000 series cars operating on that line produced no magnetic field in the passband of the recorders above the 60 Hz background field levels of the station.

6.6 Summary of Magnetic Field Levels

The major sources of magnetic fields associated with the Metrorail System are the currents in the rails as Metrorail cars travel, brake or accelerate and the current in the traction power control circuits beneath the cars. These add to the background fields in the stations which arise primarily from the Earth's magnetism and 60 Hz electric power circuits in or near the stations to produce the total field environment of the stations. Appendices O through V contain the data from measurements of the total ULF and ELF magnetic field environment at the Grosvenor platform. Appendices AB through AG contain corresponding data for the Gallery Place transfer station platform. Due to the large temporal variability of the fields at the edge of the station platforms, they must be quantified statistically.

In order to produce general and reliable descriptions of field intensity, datasets found to have similar characteristics are pooled. Positions along the edge of the platform influenced the temporal characteristics of the field, but did not influence frequency, intensity, nor spatial variability to any large extent. Hence, all of the datasets at the platform edge at each station are pooled.

Table 6-4 has the overall statistics of the combined datasets MET015, MET017, MET022 and MET024. These are all vertical profile datasets taken at the safety line near the edge of the Grosvenor platform. Of the 55 sample points, 23 are on the southbound side and 32 on the northbound. Of the 32 on the northbound side, 21 are in the center of the platform and 11 at one end. Data were also taken at both arriving and departing ends of the platform. All data were taken while some train activity was present. The combined datasets give a good indication as to the field levels that can be expected at the safety line. The maximum readings presented in Table 6-4 are associated with train passes such as the one shown in Figure 6-3. Rapid attenuation of the maximum fields with increased heights is evident in all frequency bands except the power frequency band. That is because the Metrorail System does not produce significant fields in the power frequency band. The small coefficient of variation of the power frequency fields (which means that they are relatively constant over time) further indicates that they arise from sources other than the transportation system. Average field levels are to a large extent dominated by fields from sources other than the Metrorail System, therefore there is much less evidence of field attenuation with height in the average field strength data.

TABLE 6-4

**STATISTICAL SUMMARY OF THE MAGNETIC FIELD LEVEL OF COMBINED
VERTICAL DATASETS AT THE SAFETY LINE AT THE GROSVENOR PASSENGER
STATION PLATFORM (DATASETS MET015, 017, 022 AND MET024)**

MET015, 017, 022, 024 - GROSVENOR STATION PLATFORM				TOTAL OF 55 SAMPLES		
FREQUENCY BAND	HEIGHT ABOVE FLOOR (cm)	MINIMUM MAGNETIC FIELD (mG)	MAXIMUM MAGNETIC FIELD (mG)	AVERAGE MAGNETIC FIELD (mG)	STANDARD DEVIATION (mG)	COEFFICIENT OF VARIATION (%)
STATIC	10	110.95	2065.36	471.84	391.77	83.03
	60	226.00	1562.41	443.50	264.46	59.63
	110	234.84	1217.60	432.56	188.99	43.69
	160	328.16	983.98	469.69	119.58	25.46
5-45Hz LOW FREQ	10	0.21	20.41	1.27	2.76	218.21
	60	0.17	7.63	0.82	1.13	137.19
	110	0.07	2.25	0.56	0.56	99.99
	160	0.20	1.67	0.63	0.43	67.10
50-60Hz PWR FREQ	10	1.25	3.67	2.11	0.83	39.19
	60	0.89	2.56	1.62	0.48	29.67
	110	0.87	2.24	1.54	0.39	25.15
	160	0.96	2.08	1.51	0.36	23.60
65-300Hz PWR HARM	10	0.12	57.74	2.62	7.74	294.93
	60	0.17	31.96	1.29	4.26	330.00
	110	0.19	20.71	0.98	2.73	279.08
	160	0.20	11.22	0.73	1.48	203.85
305-2560Hz HIGH FREQ	10	0.33	25.97	1.32	3.41	257.85
	60	0.22	13.19	0.71	1.72	244.57
	110	0.20	9.00	0.53	1.18	223.61
	160	0.20	4.03	0.45	0.56	123.96
5-2560Hz ALL FREQ	10	1.55	66.62	4.31	8.71	202.24
	60	1.13	35.45	2.70	4.55	168.85
	110	1.00	22.73	2.26	2.85	126.50
	160	1.32	12.08	2.04	1.44	70.63

The average field levels at the Grosvenor Station for the power frequency and power harmonic bands reported in Table 6-2 can be combined to determine the field level which would be measured by an instrument having a bandwidth similar to the EMDEX-II recorders. The average field level of 1.83 mG at 110 cm above the platform obtained in that way from the data in Table 6-4 falls between the average field levels (1.55 mG and 1.93 mG, Table 6-3) measured by the EMDEX recorders over a similar frequency band. The average and maximum static field levels reported in Table 6-2 are somewhat lower than those obtained from DAT recordings at the Grosvenor Station and reported in Table 6-3. That is expected because the periodic waveform sampling misses some of the high-strength fields which existed only for very brief periods of time.

Table 6-5 has the overall statistics of dataset MET019. This is a vertical profile dataset taken in the middle of the Grosvenor platform, near the bottom of the escalator. It is indicative of the field levels that can be expected at times of no train activity and at a central location on the platform. The similarity between the average time varying background field levels when no trains are near the station, as shown in Table 6-5, to the average field levels given in Table 6-4 for the edge of the platform when trains are active demonstrates the small extent to which the Metrorail transportation system contributes to the average field levels on the station platform.

MET021 is a dataset containing vertical profile measurements made in the Grosvenor Station while riding up and down the escalator. Measurements were taken to determine whether significant fields were present from the motors or other parts of the escalator. The results are summarized in Table 6-6.

Table 6-7 has the overall statistics of the combined datasets MET031 and MET033. These are vertical profile datasets taken at the safety line at the edge of the Green Line platform at the Gallery Place transfer station, one on each side of the platform. The combination gives a good indication of the field levels that can be expected at the safety line. The maximum field readings which represent fields from the transportation system, are substantially less at this station than at Grosvenor Station (Table 6-4). Most of the difference in the time varying field levels is due to the absence of fields from chopper power control systems found at the Grosvenor Station. The maximum static field levels at Gallery Place Station are also substantially less than at Grosvenor Station. That, too, might be due to the absence of 3000 series cars on the Green Line.

Table 6-8 has the overall statistics of the combined datasets MET035 and MET037. These are both vertical profile datasets taken at two locations on the mezzanine of the Gallery transfer station. The maximum reading of 1.31 mG occurred in the high frequency range

*This is a
Repeat page*

The average field levels at the Grosvenor Station for the power frequency and power harmonic bands reported in Table 6-2 can be combined to determine the field level which would be measured by an instrument having a bandwidth similar to the EMDEX-II recorders. The average field level of 1.83 mG at 110 cm above the platform obtained in that way from the data in Table 6-4 falls between the average field levels (1.55 mG and 1.93 mG, Table 6-3) measured by the EMDEX recorders over a similar frequency band. The average and maximum static field levels reported in Table 6-2 are somewhat lower than those obtained from DAT recordings at the Grosvenor Station and reported in Table 6-3. That is expected because the periodic waveform sampling misses some of the high-strength fields which existed only for very brief periods of time.

Table 6-5 has the overall statistics of dataset MET019. This is a vertical profile dataset taken in the middle of the Grosvenor platform, near the bottom of the escalator. It is indicative of the field levels that can be expected at times of no train activity and at a central location on the platform. The similarity between the average time varying background field levels when no trains are near the station, as shown in Table 6-5, to the average field levels given in Table 6-4 for the edge of the platform when trains are active demonstrates the small extent to which the Metrorail transportation system contributes to the average field levels on the station platform.

MET021 is a dataset containing vertical profile measurements made in the Grosvenor Station while riding up and down the escalator. Measurements were taken to determine whether significant fields were present from the motors or other parts of the escalator. The results are summarized in Table 6-6.

Table 6-7 has the overall statistics of the combined datasets MET031 and MET032. These are vertical profile datasets taken at the safety line at the edge of the Green Line platform at the Gallery Place transfer station, one on each side of the platform. The combination gives a good indication of the field levels that can be expected at the safety line. The maximum field readings which represent fields from the transportation system, are substantially less at this station than at Grosvenor Station (Table 6-4). Most of the difference in the time varying field levels is due to the absence of fields from chopper power control systems found at the Grosvenor Station. The maximum static field levels at Gallery Place Station are also substantially less than at Grosvenor Station. That, too, might be due to the absence of 3000 series cars on the Green Line.

Table 6-8 has the overall statistics of the combined datasets MET035 and MET037. These are both vertical profile datasets taken at two locations on the mezzanine of the Gallery transfer station. The maximum reading of 1.31 mG occurred in the high frequency range

TABLE 6-5

STATISTICAL SUMMARY OF THE MAGNETIC FIELD LEVEL AT VARIOUS HEIGHTS ABOVE THE FLOOR AT THE BOTTOM OF ESCALATOR AT THE GROSVENOR PASSENGER STATION PLATFORM (DATASET MET019)

MET019 - BOTTOM OF ESCALATOR, GROSVENOR STATION		TOTAL OF 6 SAMPLES				
FREQUENCY BAND	HEIGHT ABOVE FLOOR (cm)	MINIMUM MAGNETIC FIELD (mG)	MAXIMUM MAGNETIC FIELD (mG)	AVERAGE MAGNETIC FIELD (mG)	STANDARD DEVIATION (mG)	COEFFICIENT OF VARIATION (%)
STATIC	10	641.79	658.72	649.99	6.42	0.99
	60	611.36	621.15	617.05	3.95	0.64
	110	588.16	601.82	592.08	4.99	0.84
	160	608.97	622.39	615.28	5.07	0.82
5-45Hz LOW FREQ	10	0.22	2.87	0.83	1.01	122.07
	60	0.20	2.69	0.74	0.96	129.68
	110	0.12	2.60	0.69	0.95	136.91
	160	0.20	2.94	0.80	1.06	132.53
50-60Hz PWR FREQ	10	1.69	1.75	1.72	0.02	1.37
	60	1.79	1.89	1.84	0.05	2.53
	110	1.82	1.88	1.84	0.02	1.34
	160	1.85	1.96	1.91	0.05	2.45
65-300Hz PWR HARM	10	0.27	0.35	0.29	0.03	10.47
	60	0.40	0.42	0.41	0.01	2.33
	110	0.53	0.65	0.60	0.05	8.09
	160	0.67	0.76	0.72	0.04	5.00
305-2560Hz HIGH FREQ	10	0.12	0.18	0.13	0.02	17.39
	60	0.16	0.20	0.17	0.02	9.64
	110	0.23	0.25	0.23	0.01	2.73
	160	0.28	0.32	0.30	0.01	4.86
5-2560Hz ALL FREQ	10	1.79	3.36	2.07	0.64	30.74
	60	1.92	3.26	2.16	0.54	24.85
	110	1.94	3.24	2.19	0.51	23.33
	160	2.08	3.55	2.36	0.58	24.75

TABLE 6-6

STATISTICAL SUMMARY OF THE MAGNETIC FIELD LEVEL AT VARIOUS HEIGHTS ABOVE THE MOVING STEPS WHILE RIDING UP AND DOWN ON THE ESCALATOR AT THE GROSVENOR PASSENGER STATION PLATFORM (DATASET MET021)

MET021 - ON ESCALATOR, GROSVENOR STATION				TOTAL OF 13 SAMPLES		
FREQUENCY BAND	HEIGHT ABOVE STEP (cm)	MINIMUM MAGNETIC FIELD (mG)	MAXIMUM MAGNETIC FIELD (mG)	AVERAGE MAGNETIC FIELD (mG)	STANDARD DEVIATION (mG)	COEFFICIENT OF VARIATION (%)
STATIC	10	148.19	996.22	356.64	262.65	73.65
	60	117.78	1009.35	398.03	298.68	75.04
	110	141.30	1089.70	455.26	350.49	76.99
	160	142.83	1006.46	484.23	308.10	63.63
5-45Hz LOW FREQ	10	0.25	2.36	0.64	0.55	86.54
	60	0.21	0.90	0.46	0.23	49.64
	110	0.14	1.00	0.41	0.25	59.09
	160	0.50	1.34	0.66	0.23	33.90
50-60Hz PWR FREQ	10	0.31	4.43	1.09	1.10	101.08
	60	0.48	1.82	0.98	0.41	41.97
	110	0.80	1.77	1.25	0.29	23.26
	160	0.88	2.15	1.51	0.35	23.54
65-300Hz PWR HARM	10	0.05	0.85	0.21	0.21	97.84
	60	0.16	0.68	0.23	0.14	58.77
	110	0.30	0.82	0.45	0.13	29.08
	160	0.45	0.91	0.52	0.13	25.00
305-2560Hz HIGH FREQ	10	0.06	0.26	0.11	0.06	57.58
	60	0.05	0.21	0.11	0.06	52.16
	110	0.11	0.60	0.27	0.16	56.93
	160	0.20	1.47	0.80	0.49	60.90
5-2560Hz ALL FREQ	10	0.51	5.09	1.32	1.22	92.45
	60	0.59	1.98	1.14	0.43	37.69
	110	1.11	1.91	1.46	0.24	16.47
	160	1.50	2.56	1.98	0.34	17.38

TABLE 6-7

**STATISTICAL SUMMARY OF THE MAGNETIC FIELD LEVEL OF COMBINED
VERTICAL DATASETS AT THE SAFETY LINE OF THE LOWER PLATFORM AT THE
GALLERY PASSENGER TRANSFER STATION (DATASETS MET031 AND MET033)**

MET031, 33 - GALLERY PLACE PLATFORM, VERTICAL		TOTAL OF 37 SAMPLES				
FREQUENCY BAND	HEIGHT ABOVE FLOOR (cm)	MINIMUM MAGNETIC FIELD (mG)	MAXIMUM MAGNETIC FIELD (mG)	AVERAGE MAGNETIC FIELD (mG)	STANDARD DEVIATION (mG)	COEFFICIENT OF VARIATION (%)
STATIC	10	93.73	874.66	316.14	176.35	55.78
	60	210.80	952.79	379.37	136.40	35.96
	110	306.48	833.28	399.80	86.73	21.69
	160	384.51	775.02	438.87	62.60	14.26
5-45Hz LOW FREQ	10	0.25	12.53	1.24	2.36	191.04
	60	0.18	12.74	1.13	2.52	223.41
	110	0.07	9.89	0.80	1.75	219.48
	160	0.18	6.52	0.65	1.08	164.97
50-60Hz PWR FREQ	10	0.26	1.77	0.37	0.29	78.12
	60	0.16	1.13	0.27	0.17	62.19
	110	0.20	0.68	0.30	0.08	28.11
	160	0.14	0.59	0.21	0.09	42.88
65-300Hz PWR HARM	10	0.12	8.41	0.68	1.36	199.29
	60	0.17	6.06	0.52	0.96	186.54
	110	0.17	4.80	0.46	0.75	161.38
	160	0.19	5.21	0.40	0.82	202.60
305-2560Hz HIGH FREQ	10	0.73	3.27	1.05	0.44	41.78
	60	0.52	2.21	0.73	0.30	40.70
	110	0.37	1.51	0.53	0.20	37.80
	160	0.31	1.45	0.43	0.19	45.63
5-2560Hz ALL FREQ	10	0.98	15.54	1.95	2.66	136.16
	60	0.73	12.90	1.61	2.63	163.45
	110	0.57	10.01	1.23	1.83	149.60
	160	0.50	6.64	0.98	1.31	133.17

TABLE 6-8

**STATISTICAL SUMMARY OF THE MAGNETIC FIELD LEVEL OF COMBINED
VERTICAL DATASETS AT THE MEZZANINE OF THE GALLERY PASSENGER
TRANSFER STATION (DATASETS MET035 AND MET037)**

MET035, 37 - GALLERY PLACE STATION MEZZANINE				TOTAL OF 22 SAMPLES		
FREQUENCY BAND	HEIGHT ABOVE FLOOR (cm)	MINIMUM MAGNETIC FIELD (mG)	MAXIMUM MAGNETIC FIELD (mG)	AVERAGE MAGNETIC FIELD (mG)	STANDARD DEVIATION (mG)	COEFFICIENT OF VARIATION (%)
STATIC	10	318.95	1003.71	438.45	236.54	53.95
	60	340.37	789.56	440.59	136.27	30.93
	110	341.50	685.80	433.19	95.58	22.06
	160	420.70	643.94	491.00	53.80	10.96
5-45Hz LOW FREQ	10	0.25	0.82	0.36	0.14	38.48
	60	0.17	0.55	0.27	0.12	45.65
	110	0.06	0.48	0.17	0.12	70.81
	160	0.19	0.68	0.30	0.15	49.90
50-60Hz PWR FREQ	10	0.21	0.46	0.40	0.08	19.69
	60	0.14	0.30	0.24	0.04	19.03
	110	0.25	0.44	0.29	0.04	15.28
	160	0.19	0.27	0.22	0.02	11.30
65-300Hz PWR HARM	10	0.06	0.18	0.09	0.04	41.90
	60	0.15	0.24	0.17	0.02	14.10
	110	0.17	0.52	0.31	0.10	30.71
	160	0.18	0.47	0.24	0.11	46.79
305-2560Hz HIGH FREQ	10	0.08	0.31	0.13	0.05	37.53
	60	0.07	0.24	0.12	0.04	35.05
	110	0.07	0.84	0.14	0.16	121.02
	160	0.08	1.31	0.26	0.40	155.61
5-2560Hz ALL FREQ	10	0.50	0.91	0.57	0.09	15.56
	60	0.34	0.66	0.42	0.10	22.50
	110	0.36	1.07	0.50	0.18	36.23
	160	0.34	1.53	0.55	0.39	71.19

at the 160 cm height. All other readings, in all ranges, were below 1.0 mG.

6.7 Summary of Electric Field Levels

No significant levels of time varying electric field were present on Metrorail station platforms or mezzanines. The average levels were typically well less than 1 V/m with peak levels of about 2 V/m. The plot of the electric field as a function of frequency and time for the electric field measurement on the mezzanine at the Gallery Place Station contained in Appendix AG is an example of the electric field data measured in the stations.

7.0 POWER SUPPLY SYSTEM MEASUREMENTS *the*

The power supply system for the Metrorail is comprised of small traction power supply stations spaced every few miles along each line. These stations are combined transformer and rectifier facilities which convert commercial three-phase 60 Hz ac electric power to 750 V dc to feed third rail. This section of the report covers the fields recorded in the vicinity of two different traction power stations.

7.1 Measurement Locations

Figure 7-1 shows a plan view of the traction power supply station (TPSS) located south of Shady Grove. This is a typical station of the system. It is a brick building which measures 45' by 18' and is located adjacent to the tracks. Power comes in at 13.8 kV, 60 Hz and is transformed into 750 V dc, which in turn is used to supply the third rail along the line.

As shown in the figure, fixed position extended time measurements were made at locations around the three sides of the station where unrestricted access is possible. A fence prevents public access to the side of the building along the tracks. The measurements were taken with the staff in a horizontal position at 1 meter height, perpendicular to the wall, so as to record any attenuation of the field produced by equipment within the building. The five profiles, denoted as A, B, B', C and D, correspond to datasets MET038 through MET042, respectively. The plots of the recorded data are given in Appendices AH through AL, respectively. The data was collected between 08:39 and 09:09 on May 20, 1992. The reference probe was placed, in all cases, at a distance of 15 feet from the wall, in line with the staff for that profile. No measurements were made within restricted areas such as the interior of the building or the fenced area between the tracks and the building.

Figure 7-2 shows the traction power supply station at the service facility at Shady Grove. This is part of a larger complex which reportedly supplies 60 Hz power to the service facility in addition to the 750 V dc traction power. The station consists of a brick building measuring approximately 86' by 48', with an attached 28' by 60' fenced transformer yard that contains two rectifier transformers and a distribution service transformer. The staff was placed horizontally, as was done at the other station, at three locations around the periphery. Profile A was taken on a line halfway between the two rectifier transformers. Profiles B and C were taken midway along the station walls indicated in the figure. The reference probe was located at a distance of 15 feet from the fence or wall, in line with the staff. Measurements were taken on May 20, 1992 from 09:42 to 10:05 and the records are datasets MET043 to MET045. Appendices AM through AO contain the plots of the data contained in these datasets.

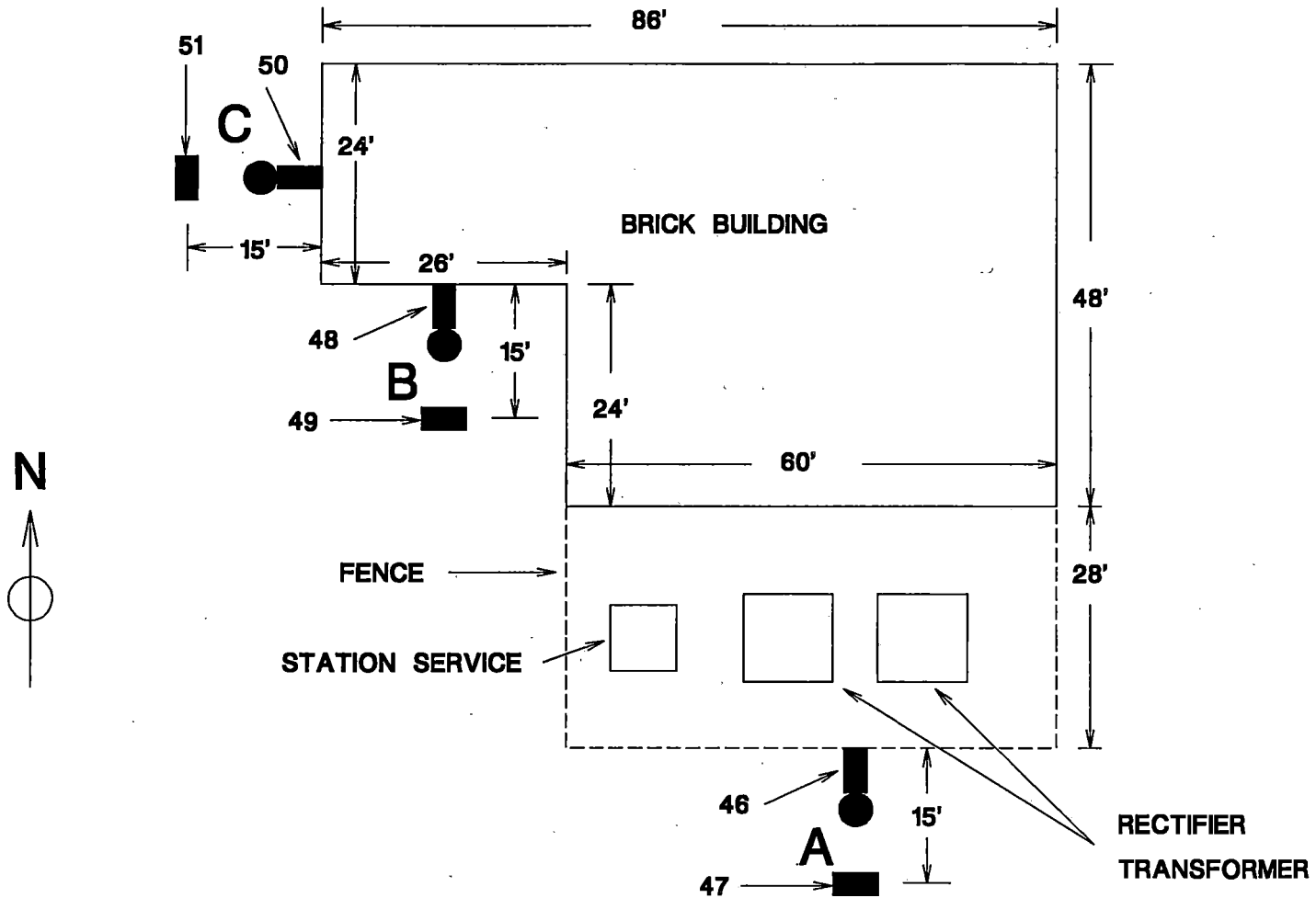

SHADY GROVE TRACTION POWER SUPPLY STATION

Figure 7-1 Repetitive waveform measurement locations at the Shady Grove power supply station.

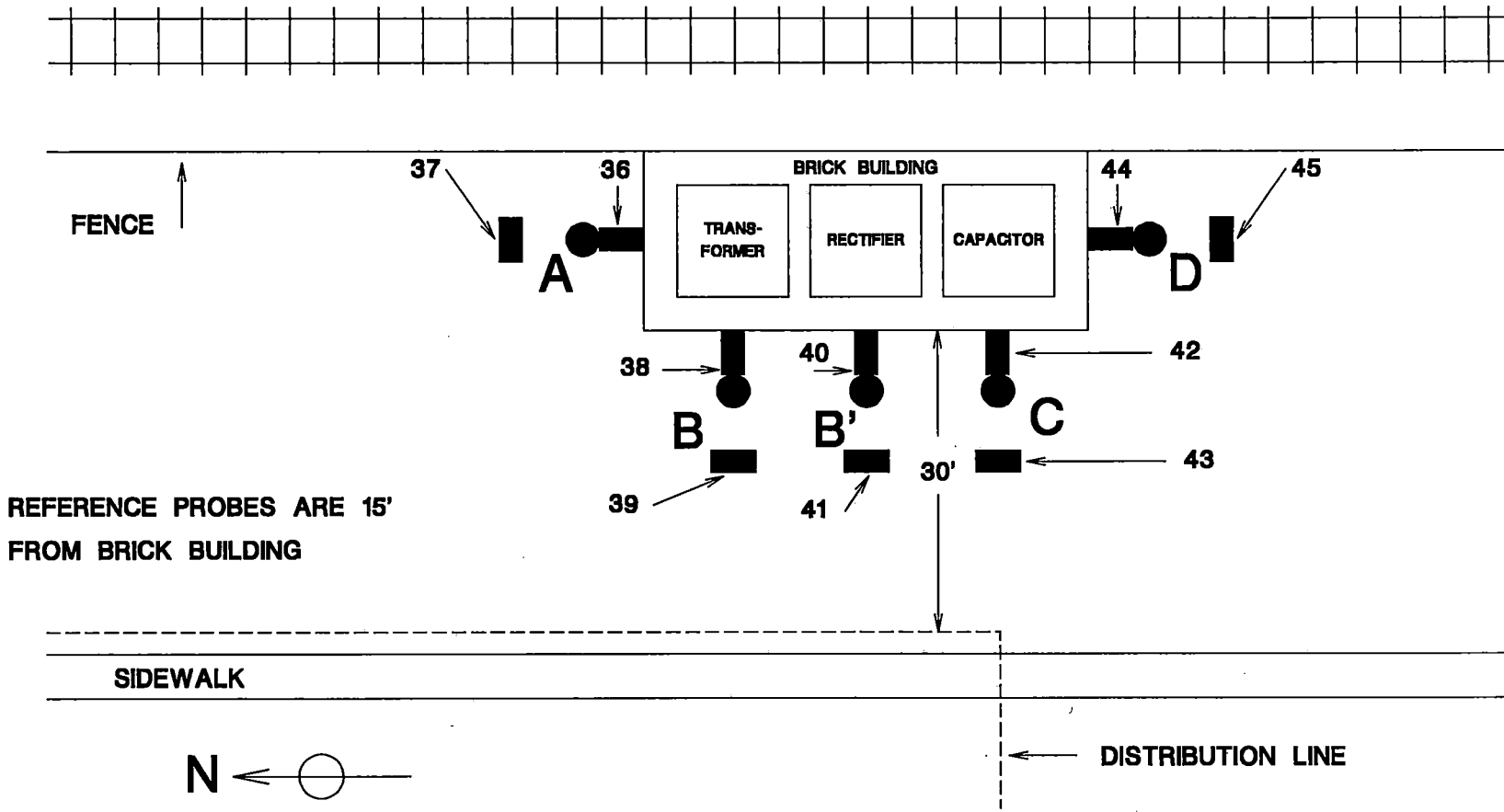

REFERENCE PROBES ARE 15'
FROM BRICK BUILDING

TRACTION POWER SUPPLY STATION SOUTH OF SHADY GROVE

Figure 7-2 Repetitive waveform measurement locations at the traction power supply station south of Shady Grove.

7.2 Repetitive Waveform Datasets

The eight repetitive waveform datasets that are associated with the traction power supply station measurements are shown in Table 2-1. The data was recorded with the *MultiWave*[™] field monitoring system. The table summarizes the pertinent information about these datasets, including the corresponding appendix number, number of samples, associated figure number and location of the probes. The appendices contain figures that are three-dimensional graphs of the magnetic field versus frequency over time, horizontal profiles of the magnetic field versus distance from the station over time, and electric field graphs where applicable.

7.3 Magnetic Field Characteristics

The magnetic fields outside traction power supply stations arise from several sources. These include equipment within the station, powerlines entering the station, traction power cables leaving the station, the nearby third rail and track circuit, and other nearby power lines or equipment unrelated to the Metrorail facilities.

The magnetic field data in all datasets, for both stations, exhibit two distinctly different temporal patterns. The first pattern is associated with the low frequency field components that are in reality the reflection of the temporal variation of the static field component produced by the dc output current of the station. The second pattern is associated with frequencies 360, 720, 1080, 1440 and 2160 Hz, which correspond to the ripple frequencies produced by the rectification process. In other words, the temporal pattern of the 720 Hz harmonic can be derived from the 360 Hz pattern by multiplying by a constant. Figure 7-3 is the 110 cm probe of dataset MET044 and is illustrative of these two patterns. Dataset MET044 is chosen because it is the one that exhibits the highest variability of the static field, thus emphasizing the distinction of these patterns. These patterns indicate that there are at least two sources of magnetic fields, namely the dc output current which fluctuates due to the power requirements of trains on the line and the circuits carrying rectifier currents.

Magnetic field measurements around the traction power supply station along the Red Line south of Shady Grove generally did not provide much evidence of an attenuation pattern away from the station except along Profile A at the north end of the building (dataset MET038). Figure 7-4 shows this attenuation for the power frequency and its harmonics, mainly the third. This MET038 dataset shows that near the building, the largest component of the magnetic field is the 180 Hz component, that is, the third harmonic. This harmonic is normally present in transformer currents because of the non-linear magnetization curve of the core material. These observations indicate that the main source of the field on

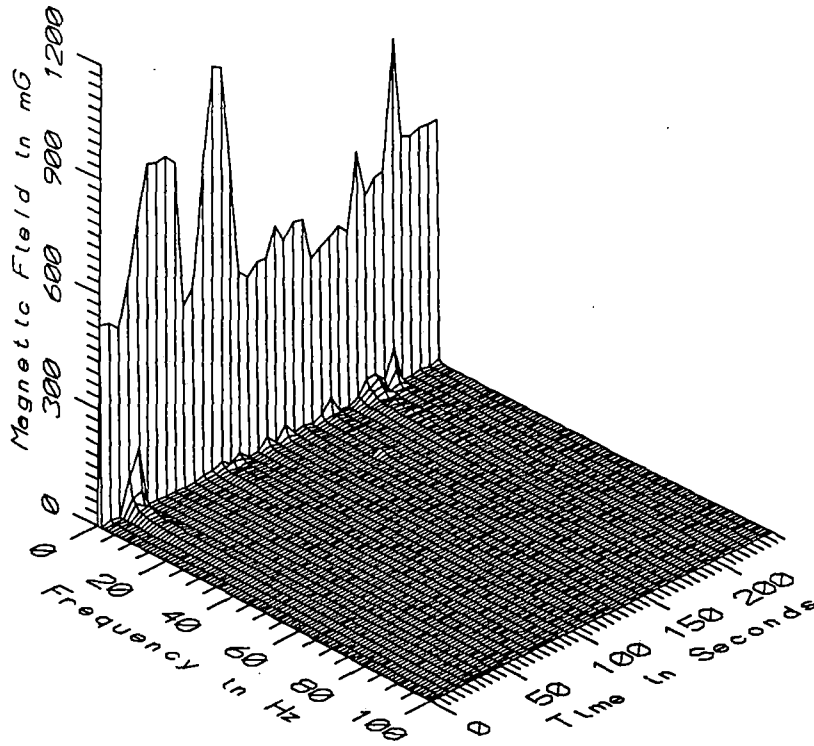

MET044 - 110cm FROM SOUTH WALL OF TRACTION POWER SUPPLY STATION

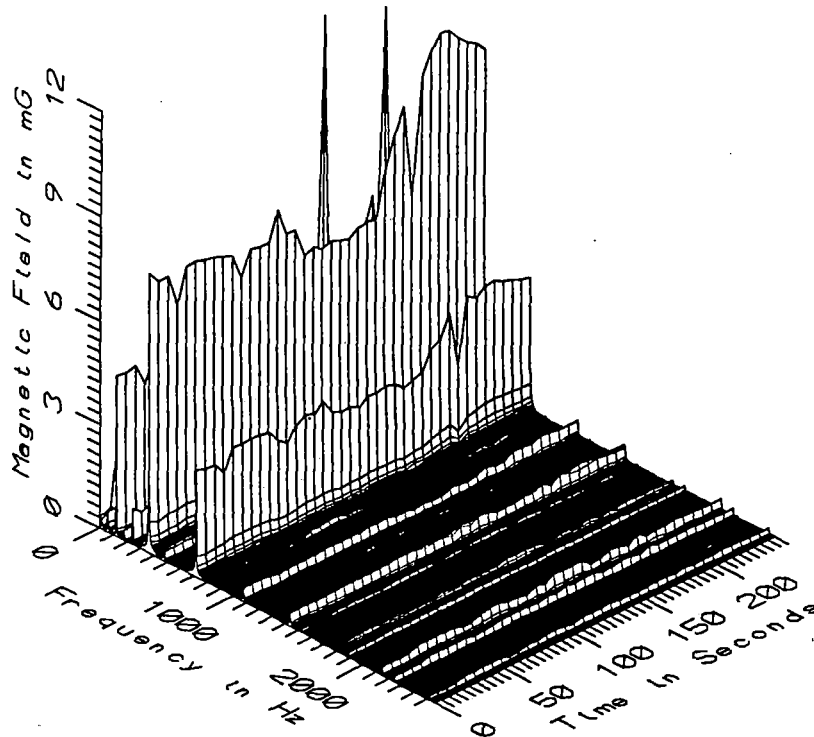

MET044 - 110cm FROM SOUTH WALL OF TRACTION POWER SUPPLY STATION

Figure 7-3 Magnetic field level, with and without the static component, at 110 cm distance from the wall at the Shady Grove traction power supply station, as a function of frequency and time.

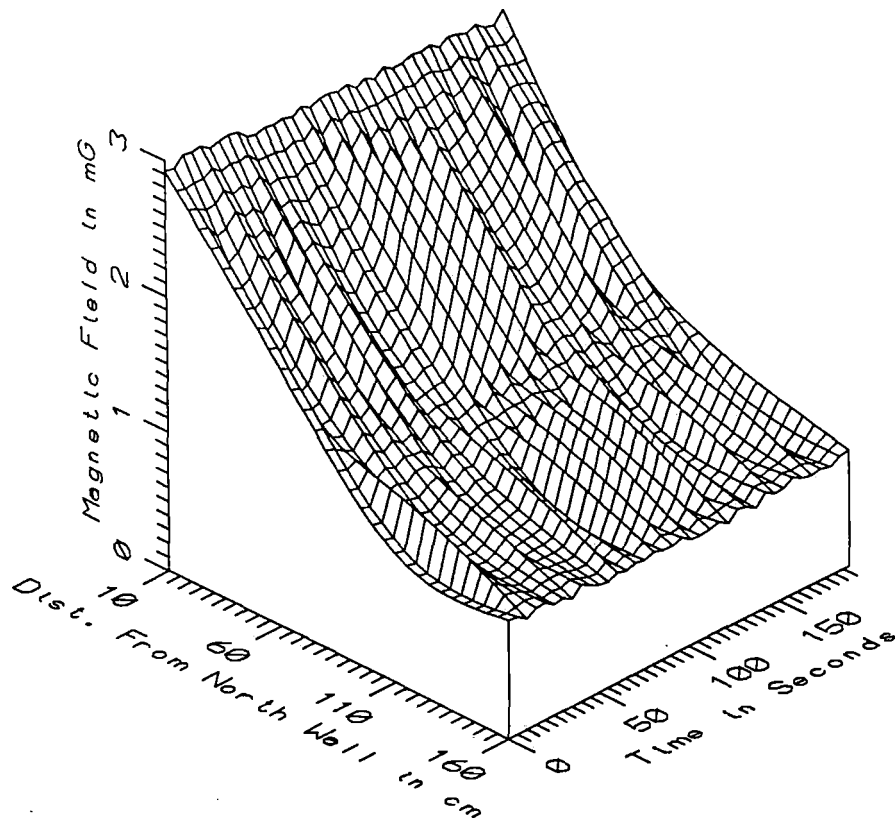

MET038 - TRACTION POWER SUPPLY STATION - POWER FREQ, 50-60Hz

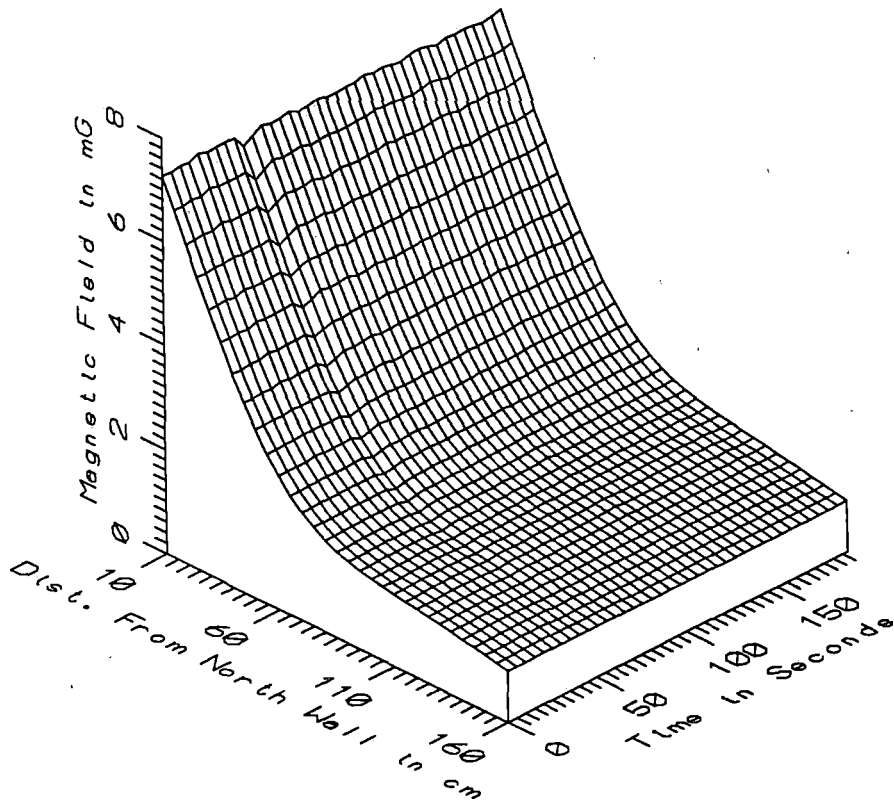

MET038 - TRACTION POWER SUPPLY STATION - POWER HARM, 65-300Hz

Figure 7-4 Magnetic field level versus distance from station wall at 1 meter height, for the power frequency (50-60 Hz) and the power frequency harmonics (65-300 Hz) components, at the traction power supply station south of Shady Grove, as a function of time.

the north side of this station is the transformer and its associated conductors, network or buswork.

Datasets MET039 through MET041, measured along Profiles B, B', and C on the west (street) side of this first station, did not exhibit any change in the 60 Hz component of the magnetic field with increased distance from the building. That result seems to suggest that the primarily 60 Hz magnetic fields measured at that side of the station originate about equally from the station and the commercial distribution line along the street.

Figure 7-5 shows a plot of the magnetic field 110 cm outside the transformer yard fence along Profile A at the traction power supply station in the Shady Grove service facility. It is part of dataset MET043 found in Appendix AM in Volume II of this report. As can be seen from the figure, there are three basic temporal patterns to the various time varying magnetic field components present at this location. The first is that of the 60 Hz field, the largest harmonic in the bottom frame. This appears to result from current in the cables and buswork on the primary side of the rectifier transformers because the intensity of this component appears to correlate with the dc output current of the station as evidenced by the small static field additions to the 500 mG geomagnetic field at the measurement location. The second pattern is that clearly evident in the sixth (360 Hz) and twelfth (720 Hz) harmonic components which are the rectification harmonics. Finally, there is another group of field components 60 Hz above and 60 Hz below the rectifier ripple harmonics, most notably the seventh harmonic at 420 Hz, that show little or no temporal variability. The field levels of this dataset are of the same order of magnitude as those measured around the other traction power supply station south of Shady Grove.

Datasets MET044 and MET045 exhibit larger levels of both ac and dc fields than any of the other profiles. Figure 7-3 from dataset MET044 is an example. These were measured along Profiles B and C outside the station in the Shady Grove service facility. Neither profile shows discernable attenuation with distance from the wall. The frequency components and their patterns are similar to those observed at other locations around both traction power supply stations, indicating that the same sources are contributing to these fields. However, these two datasets appear to be more representative of the fields to be encountered outside the dc side of a station or near cable circuits from the station to the tracks because they show greater evidence of static fields from dc output current, have small 60 Hz components, have large ripple frequency components, and have low frequency field components arising from changing static field levels. The datasets measured along the other profiles are more indicative of the fields to be encountered outside the ac side of a station where the 60 Hz component tends to be dominant.

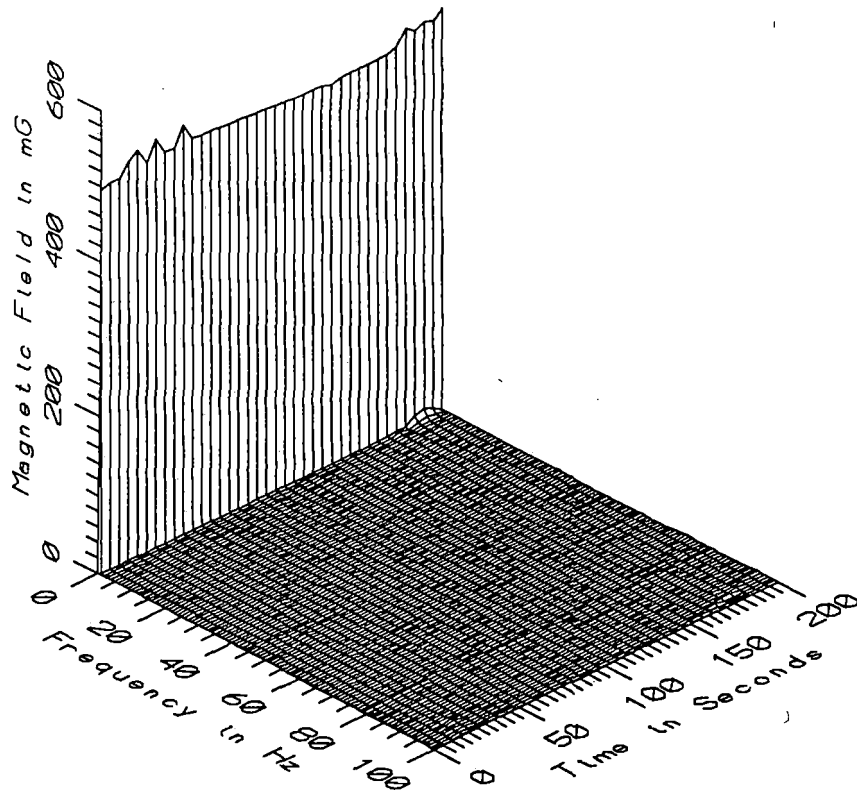

MET043 - 110cm FROM SOUTH FENCE OF TRACTION POWER SUPPLY STATION

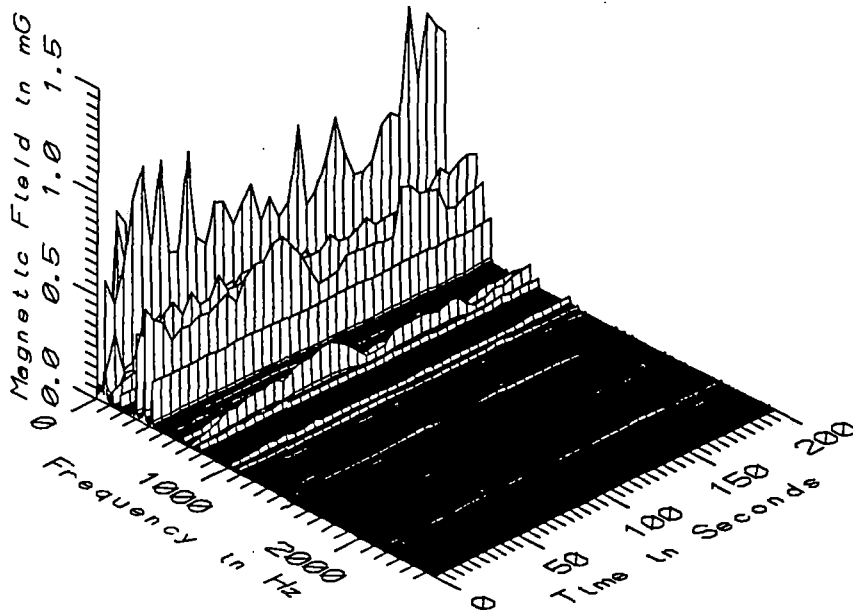

MET043 - 110cm FROM SOUTH FENCE OF TRACTION POWER SUPPLY STATION

Figure 7-5 Magnetic field level, with and without the static component, at 110 cm distance from fence and 1 meter height, at the Shady Grove traction power supply station, as a function of frequency and time.

In summary, the repetitive waveform data showing magnetic field characteristics around the traction power supply stations indicate the presence of multiple field sources within the station having unique frequency and temporal patterns. In some locations, there are wide spatial variations in field characteristics and strength, depending on the proximity to the different type of current carrying apparatus.

7.4 DAT Waveform Data

Magnetic field data from the reference probe of the *MultiWave*™ System was recorded continuously with a digital audio tape recorder during the measurements around the traction power supply stations. Those recordings were scanned for transient or rapidly changing field conditions not found in the repetitive waveform data. No such transient conditions were found.

7.5 EMDEX-II Data

The EMDEX-II recorders are carried on a person and thus reflect the history in time and space of that person. As mentioned previously, the researchers in this study did wander about outside the stations, not following any particular path. Moreover, the frequency response of the EMDEX-II instrument is such that it does not capture low frequencies (for discussion see section 2.8). Thus measurements with the EMDEX are difficult to correlate with other measurements. However, the time course and the summary statistics of both EMDEX-II recordings are included in this report.

Figure 7-6 shows the time course plots for the EMDEX-II recordings outside the TPSS along the Red Line south of Shady Grove. It spans the time period from 08:50 to 09:09 hours on May 20, 1992. The field levels recorded by the two EMDEX units differ from approximately 8:56 to 9:07 because the person wearing EMDEX 1 crossed the street to measure magnetic fields beneath a large distribution line and around some cable circuits descending a pole where the magnetic fields were larger. The person with EMDEX 2 remained in the vicinity of the traction power substation. Figure 7-7 shows the time course plots for the EMDEX-II recordings outside the TPSS at the Shady Grove service facility. It spans the time period from 09:40 to 10:05 hours on May 20, 1992. Table 7-1 shows the statistics for all of the recordings near the traction power supply stations.

T.P.S.S. SOUTH OF SHADY GROVE

EmdexII Data From May 20, 1992

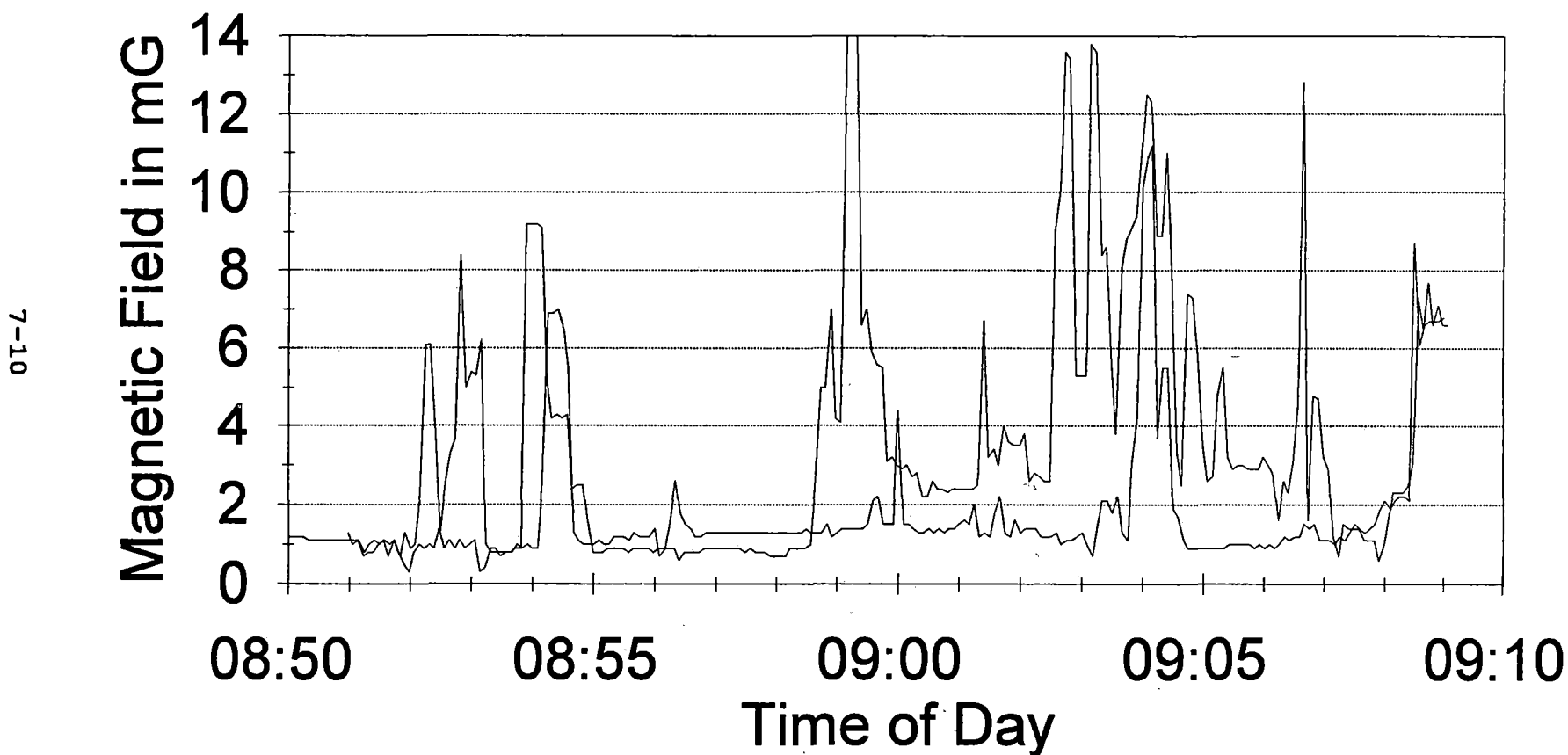

Figure 7-6

Magnetic field levels recorded outside the traction power supply station 2.5 miles south of Shady Grove using the EMDEX-II recorders, as a function of time.

T.P.S.S AT SHADY GROVE

EmdexII Data From May 20, 1992

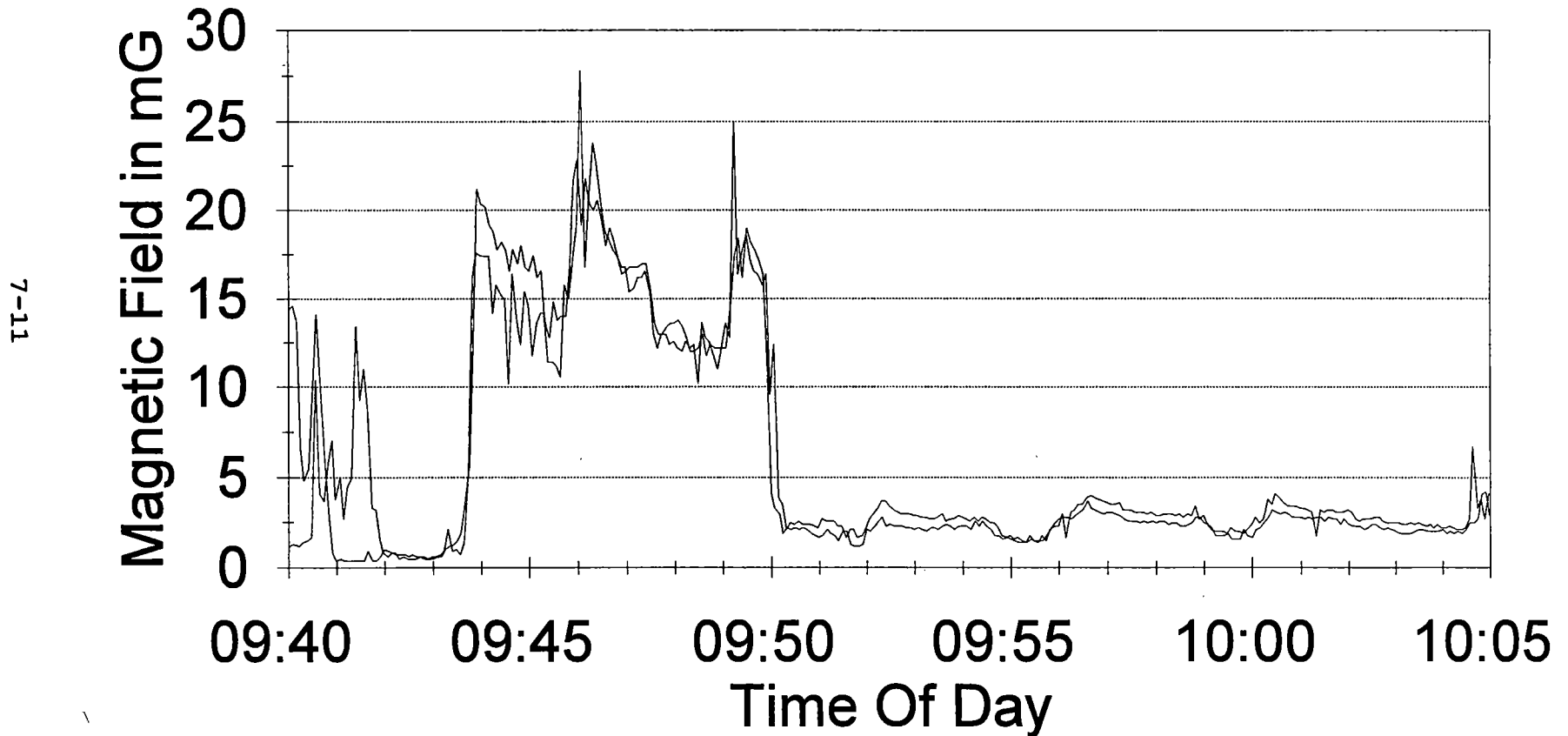

Figure 7-7

Magnetic field levels recorded outside the Shady Grove traction power supply station using the EMDEX-II recorders, as a function of time.

TABLE 7-1

**STATISTICAL SUMMARY OF MAGNETIC FIELDS IN MG
RECORDED AT TRACTION POWER SUPPLY STATIONS
USING EMDEX-II DATA RECORDERS**

	AVERAGE	MAXIMUM
TPSS SOUTH OF SHADY GROVE		
EMDEX #1	3.45	14.0
EMDEX #2	1.96	11.2
BOTH	2.70	14.0
TPSS AT SHADY GROVE		
EMDEX #1	5.91	27.8
EMDEX #2	5.83	22.8
BOTH	5.87	27.8

7.6 Summary of Magnetic Field Levels

Appendices AH through AO contain the figures of the magnetic field plots for the two traction power supply stations reported in this section. As previously mentioned, the major source of ac magnetic fields is the current carried by the equipment and structures inside the station. There are two sets of frequencies, one set associated with the main power supply and the other associated with the rectifiers. Also, there are low frequency components that are associated with the perturbation of the static field.

Tables 7-2 through 7-6 summarize the statistics of the pertinent data of the two sites. Each table shows the minimum, maximum and average field levels, as well as the standard deviation and coefficient of variation. The results are summarized by the same set of five frequency ranges used throughout this report, and by the distance from the wall or fence of the station, as given by the four sensor locations mounted on the staff.

Table 7-2 has the overall statistics of the MET038 dataset, taken at the north wall of the TPSS on the Red Line south of Shady Grove (Profile A on Figure 7-1). This measurement is presumed to be close to the transformer because of the prominent 180 Hz field component (7.2 mG average at 10 cm from the wall) and rapid field attenuation rate. The third order curve fit, (best suited for a point source or transformer) for either the maximum or the average readings, indicates that the virtual source is at a distance of

TABLE 7-2

STATISTICAL SUMMARY OF THE MAGNETIC FIELD LEVEL AT VARIOUS DISTANCES FROM THE NORTH WALL, OUTSIDE THE TRACTION POWER SUPPLY STATION 2.5 MILES SOUTH OF SHADY GROVE (DATASET MET038)

MET038 - T.P.S.S. SOUTH OF SHADY GROVE, FROM NORTH WALL TOTAL OF 38 SAMPLES						
FREQUENCY BAND	DIST FROM WALL (cm)	MINIMUM MAGNETIC FIELD (mG)	MAXIMUM MAGNETIC FIELD (mG)	AVERAGE MAGNETIC FIELD (mG)	STANDARD DEVIATION (mG)	COEFFICIENT OF VARIATION (%)
STATIC	10	572.41	614.11	579.22	10.41	1.80
	60	534.24	562.01	540.66	7.91	1.46
	110	526.56	572.97	538.86	13.13	2.44
	160	529.74	583.83	544.10	15.50	2.85
5-45Hz LOW FREQ	10	0.29	1.03	0.44	0.14	33.02
	60	0.18	0.73	0.30	0.11	36.43
	110	0.12	0.51	0.23	0.08	36.39
	160	0.22	0.49	0.30	0.07	22.65
50-60Hz PWR FREQ	10	2.79	2.97	2.87	0.04	1.52
	60	1.52	1.86	1.71	0.11	6.48
	110	0.89	1.20	1.02	0.09	8.58
	160	0.75	0.85	0.80	0.03	3.32
65-300Hz PWR HARM	10	7.04	7.34	7.22	0.05	0.73
	60	2.50	2.61	2.58	0.02	0.69
	110	1.38	1.42	1.40	0.01	0.78
	160	0.96	0.98	0.97	0.01	0.60
305-2560Hz HIGH FREQ	10	2.15	2.34	2.23	0.05	2.38
	60	0.70	0.91	0.80	0.06	7.39
	110	0.37	0.45	0.40	0.02	5.61
	160	0.23	0.31	0.24	0.02	8.26
5-2560Hz ALL FREQ	10	7.95	8.25	8.10	0.07	0.81
	60	3.10	3.31	3.21	0.06	1.96
	110	1.71	1.90	1.79	0.05	2.80
	160	1.28	1.39	1.32	0.03	2.02

TABLE 7-3

STATISTICAL SUMMARY OF THE MAGNETIC FIELD LEVEL AT VARIOUS DISTANCES FROM THE WALLS, OF COMBINED DATASETS OUTSIDE THE TRACTION POWER SUPPLY STATION OF SHADY GROVE (DATASETS MET038 THROUGH MET042)

MET038-042 - T.P.S.S SOUTH OF SHADY GROVE				TOTAL OF 214 SAMPLES		
FREQUENCY BAND	DIST FROM WALL (cm)	MINIMUM MAGNETIC FIELD (mG)	MAXIMUM MAGNETIC FIELD (mG)	AVERAGE MAGNETIC FIELD (mG)	STANDARD DEVIATION (mG)	COEFFICIENT OF VARIATION (%)
STATIC	10	42.32	614.11	422.58	102.13	24.17
	60	280.45	562.01	455.45	46.81	10.28
	110	380.67	572.97	483.31	32.37	6.70
	160	423.29	583.83	498.90	28.51	5.71
5-45Hz LOW FREQ	10	0.29	1.19	0.45	0.15	34.07
	60	0.18	1.19	0.32	0.15	45.43
	110	0.12	1.03	0.26	0.13	50.53
	160	0.21	1.07	0.33	0.11	34.51
50-60Hz PWR FREQ	10	0.76	2.97	1.56	0.70	44.86
	60	0.67	1.86	1.20	0.33	27.54
	110	0.69	1.32	0.98	0.15	15.81
	160	0.75	1.13	0.91	0.10	10.48
65-300Hz PWR HARM	10	0.51	7.34	1.98	2.45	123.49
	60	0.51	2.61	1.09	0.72	65.93
	110	0.53	1.42	0.85	0.28	33.53
	160	0.56	0.98	0.77	0.16	20.14
305-2560Hz HIGH FREQ	10	0.17	2.34	0.76	0.74	97.82
	60	0.12	0.91	0.37	0.22	61.06
	110	0.12	0.45	0.25	0.09	36.23
	160	0.12	0.43	0.22	0.06	26.14
5-2560Hz ALL FREQ	10	1.11	8.25	2.85	2.46	86.45
	60	0.91	3.31	1.74	0.72	41.56
	110	0.92	1.90	1.37	0.25	18.32
	160	1.04	1.76	1.27	0.12	9.29

TABLE 7-4

STATISTICAL SUMMARY OF THE MAGNETIC FIELD LEVEL AT VARIOUS DISTANCES FROM THE SOUTH FENCE, OUTSIDE THE SHADY GROVE TRACTION POWER SUPPLY STATION (DATASET MET043)

MET043 - SHADY GROVE T.P.S.S, FROM SOUTH EDGE OF FENCE		TOTAL OF 38 SAMPLES				
FREQUENCY BAND	DIST FROM FENCE (cm)	MINIMUM MAGNETIC FIELD (mG)	MAXIMUM MAGNETIC FIELD (mG)	AVERAGE MAGNETIC FIELD (mG)	STANDARD DEVIATION (mG)	COEFFICIENT OF VARIATION (%)
STATIC	10	454.21	488.25	465.31	8.95	1.92
	60	469.67	505.41	481.33	9.44	1.96
	110	492.07	529.30	504.21	9.59	1.90
	160	505.80	540.88	517.57	9.15	1.77
5-45Hz LOW FREQ	10	0.27	1.56	0.51	0.32	62.62
	60	0.20	1.45	0.43	0.32	74.00
	110	0.10	1.40	0.38	0.33	86.76
	160	0.22	1.33	0.45	0.28	62.57
50-60Hz PWR FREQ	10	0.87	1.83	1.18	0.30	25.47
	60	0.69	1.55	0.98	0.24	24.93
	110	0.48	1.22	0.74	0.20	27.38
	160	0.39	0.92	0.57	0.16	27.51
65-300Hz PWR HARM	10	0.85	1.18	0.97	0.09	9.63
	60	0.63	0.86	0.73	0.07	8.99
	110	0.45	0.65	0.54	0.05	10.12
	160	0.36	0.52	0.43	0.04	10.04
305-2560Hz HIGH FREQ	10	0.67	0.85	0.75	0.04	5.74
	60	0.47	0.76	0.62	0.07	11.55
	110	0.37	0.68	0.51	0.08	16.03
	160	0.31	0.66	0.46	0.09	19.85
5-2560Hz ALL FREQ	10	1.44	2.63	1.81	0.30	16.61
	60	1.11	2.25	1.47	0.26	17.76
	110	0.82	1.75	1.15	0.24	20.90
	160	0.68	1.62	0.99	0.22	22.14

TABLE 7-5

STATISTICAL SUMMARY OF THE MAGNETIC FIELD LEVEL AT VARIOUS DISTANCES FROM THE SOUTH WALL, OUTSIDE THE SHADY GROVE TRACTION POWER SUPPLY STATION (DATASET MET044)

MET044 - SHADY GROVE T.P.S.S., FROM SOUTH WALL				TOTAL OF 38 SAMPLES		
FREQUENCY BAND	DIST FROM WALL (cm)	MINIMUM MAGNETIC FIELD (mG)	MAXIMUM MAGNETIC FIELD (mG)	AVERAGE MAGNETIC FIELD (mG)	STANDARD DEVIATION (mG)	COEFFICIENT OF VARIATION (%)
STATIC	10	578.03	1270.14	780.40	201.12	25.77
	60	522.05	1213.19	728.07	200.85	27.59
	110	433.06	1062.49	626.71	174.35	27.82
	160	443.10	1000.07	617.99	150.22	24.31
5-45Hz LOW FREQ	10	0.56	14.65	3.11	3.61	116.27
	60	0.58	13.85	2.94	3.39	115.35
	110	0.48	12.48	2.65	3.08	116.54
	160	0.47	11.73	2.49	2.87	114.97
50-60Hz PWR FREQ	10	0.95	3.21	1.64	0.54	33.16
	60	0.62	2.82	1.13	0.44	39.23
	110	0.64	2.47	1.08	0.39	36.64
	160	0.70	2.34	1.19	0.41	34.80
65-300Hz PWR HARM	10	4.78	9.61	6.14	1.32	21.54
	60	4.40	8.87	5.66	1.22	21.54
	110	3.83	7.72	4.95	1.07	21.63
	160	3.50	7.08	4.52	0.98	21.66
305-2560Hz HIGH FREQ	10	8.92	15.52	11.19	2.05	18.30
	60	8.17	14.07	10.18	1.83	17.95
	110	7.14	12.26	8.88	1.61	18.18
	160	6.64	11.14	8.14	1.46	17.87
5-2560Hz ALL FREQ	10	10.53	22.46	13.60	3.06	22.48
	60	9.58	20.69	12.40	2.83	22.85
	110	8.38	18.42	10.88	2.54	23.33
	160	7.71	16.85	10.01	2.32	23.21

TABLE 7-6

STATISTICAL SUMMARY OF THE MAGNETIC FIELD LEVEL AT VARIOUS DISTANCES FROM THE WEST WALL, OUTSIDE THE SHADY GROVE TRACTION POWER SUPPLY STATION (DATASET MET045)

MET045 - SHADY GROVE T.P.S.S, FROM WEST WALL		TOTAL OF 43 SAMPLES				
FREQUENCY BAND	DIST FROM WALL (cm)	MINIMUM MAGNETIC FIELD (mG)	MAXIMUM MAGNETIC FIELD (mG)	AVERAGE MAGNETIC FIELD (mG)	STANDARD DEVIATION (mG)	COEFFICIENT OF VARIATION (%)
STATIC	10	1473.28	1675.71	1541.76	42.20	2.74
	60	973.29	1093.30	1005.66	27.55	2.74
	110	939.32	1054.16	971.62	25.26	2.60
	160	901.08	1012.87	931.88	24.09	2.58
5-45Hz LOW FREQ	10	0.34	17.90	2.16	3.47	160.82
	60	0.32	15.71	2.02	3.18	157.55
	110	0.25	16.10	1.99	3.11	156.71
	160	0.35	16.50	2.08	3.19	153.02
50-60Hz PWR FREQ	10	0.65	1.51	0.82	0.18	21.73
	60	0.42	1.42	0.62	0.20	32.80
	110	0.35	1.31	0.55	0.20	36.92
	160	0.28	1.32	0.47	0.22	46.54
65-300Hz PWR HARM	10	3.22	5.54	3.82	0.55	14.47
	60	3.39	5.75	4.11	0.60	14.50
	110	3.18	5.62	3.90	0.61	15.53
	160	3.27	5.80	4.07	0.65	16.04
305-2560Hz HIGH FREQ	10	6.21	9.65	7.13	0.85	11.90
	60	6.57	10.73	7.78	0.96	12.34
	110	6.20	10.15	7.39	0.98	13.32
	160	6.43	10.57	7.80	1.09	13.91
5-2560Hz ALL FREQ	10	7.16	21.07	8.79	2.56	29.11
	60	7.52	19.22	9.38	2.30	24.53
	110	7.07	19.73	8.91	2.35	26.36
	160	7.30	20.34	9.37	2.44	26.07

4.8 feet (147 cm) inside the wall, a reasonable location for a piece of equipment such as a transformer.

Table 7-3 has the overall statistics for all five datasets measured around the traction power supply station south of Shady Grove (MET038 to MET042). It provides a summary of the magnetic field levels that can be expected outside such a facility. The maximum time varying field which existed close to the building in any frequency band was the 7.34 mG at the north wall of the station mentioned in the last paragraph. At distances of 1 meter or more from the building, the principal field component is the 60 Hz component which averages about 1 mG at a distance of 1.1 meter from the wall. Harmonic fields are also significant totaling to an average of about 0.9 mG at 1.1 meter from the wall. Static fields around this traction power supply station on average deviate only modestly (about 16%) from the normal background geomagnetic field level.

Table 7-4 has the overall statistics of the dataset MET043 taken at the south edge of the transformer yard fence at the traction power supply facility within the Shady Grove service facility (Profile A in Figure 7-2). It shows levels comparable to the field values measured around the first traction power station shown in Table 7-3. The maximum field component is the 60 Hz component which reaches an average of 1.2 mG near the fence but attenuates rapidly to half that value 1.6 meters from the fence.

Tables 7-5 and 7-6 show the overall statistics of the datasets MET044 and MET045, respectively. These apply to Profiles B and C at the Shady Grove traction power station shown in Figure 7-2. The fields in both of these datasets are more indicative of the fields to be encountered outside the dc side of a station. The maximum reading on Profile B (Table 7-5, dataset MET044) was 15.52 mG which occurred in the high frequency range (which contains the 360 Hz and 720 Hz rectifier ripple components), at 10 cm from the wall. The maximum reading on Profile C (Table 7-6, dataset MET045) was 17.90 mG which occurred in the low frequency range, at 10 cm from the wall. This low frequency field results from temporal changes in the static field produced by the station in this area. Low frequency fields were also clearly present along Profile B. The static field levels along Profiles B and C shown in Tables 7-5 and 7-6 deviate substantially from the 500 mG background geomagnetic field level because of the static field caused by dc currents in the station or feed cables to the tracks.

For all the cases reported in this section, the largest coefficient of variation of 161% is in the low frequency range for the 10 cm probe for dataset MET045. That is because the low frequency fields are associated with the fluctuations of the dc (static) field which result from changes in the power demand of trains operating on the Metrorail System.

7.7 Summary of Electric Field Levels

The traction power supply stations are indoor facilities fed with underground cables. Any electric fields produced by energized apparatus within the buildings are effectively contained within the building due to the electric field shielding effectiveness of the buildings. The same situation applies for the transformer yard at the Shady Grove TPSS because the energized portions of the circuits and equipment are contained in metal housings and enclosures. No electric fields were detectable outside the traction power supply station in the Shady Grove service facility but small electric fields were measured outside the power supply station along the Red Line south of Shady Grove. Figure 7-8 shows a plot of the electric field as a function of frequency and time which was measured approximately 1.8 meters away from the station wall along Profile B in Figure 7-1. A constant 60 Hz electric field of about 7 V/m was found at that point. That electric field apparently comes from the powerline along the road rather than the traction power supply station because the field is smaller at other locations similar distance from the building but further from the distribution line.

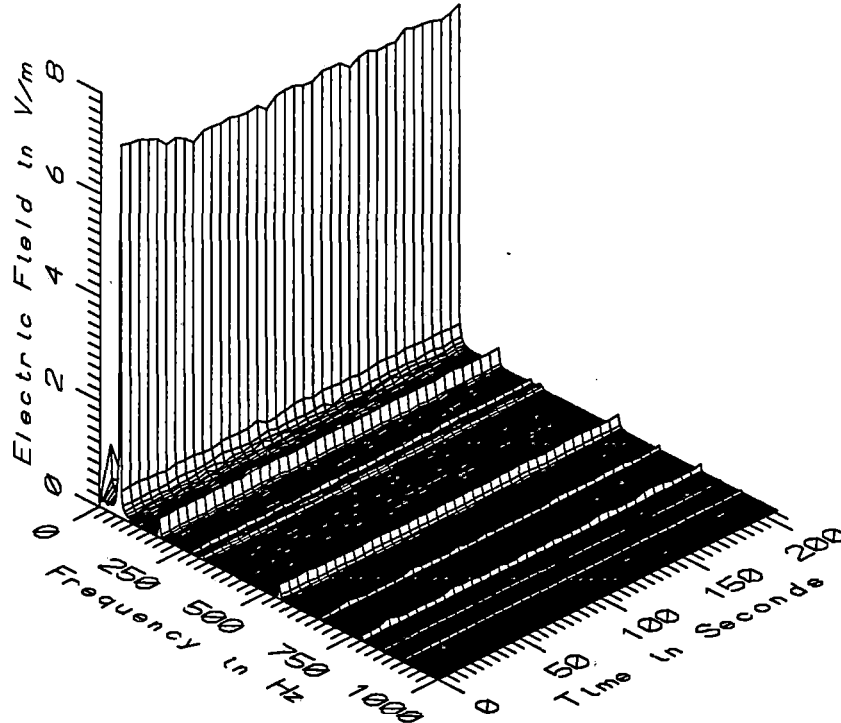

MET039 - ELECTRIC FIELD AT TRACTION POWER SUPPLY STATION

Figure 7-8 Electric time-varying field level 1.0 meter above the ground, 1.70 meters from the west wall at the traction power supply station south of Shady Grove, as a function of frequency and time.

8.0 MEASUREMENTS IN CONTROL FACILITIES

Electric and magnetic field measurements were taken in the Dispatcher's Room at the Shady Grove station as part of an effort to characterize the field environment in locations where railroad workers may encounter magnetic fields from sources other than the railroad electrical traction system.

8.1 Measurement Locations

Figure 8-1 shows the layout of the Dispatcher's Room at Shady Grove. As shown in the figure, there were three sets of fixed position, extended time measurements at the dispatcher's work station. One was a vertical profile measurement at the dispatcher's seat (Location #52 on the figure). Those data constitute dataset MET046. The second and third measurements in the dispatcher's area (Locations #53 and 54) were horizontal profiles 1.25 m from the floor at incremental distances from possible local sources of field in the dispatcher's immediate work area. Dataset MET047 was measured with one end of the staff placed against the screen of a video display monitor and dataset MET048 was measured with one end of the staff placed against the mock-up panel. All three sets of data were collected between 11:11 and 11:17 on May 20, 1992. The reference probe was placed on a table top behind the dispatcher's chair during both the horizontal and vertical profile measurements.

8.2 Repetitive Waveform Datasets

The three repetitive waveform datasets that are associated with the dispatcher's room measurements are MET046 through MET048. The data were recorded with the *MultiWave*™ field monitoring system. Table 2-1 summarizes the pertinent information about these datasets, including the number of samples, sampling interval and the appendix containing the data measured in each test. Each appendix contains plots of the magnetic field as a function of frequency and time as well as profiles showing field strength as a function of height above the floor or distance from a presumed field source over time.

8.3 Magnetic Field Characteristics

This study measured the magnetic fields inside the Dispatcher's Room at Shady Grove near the computer monitors. Control room ELF magnetic fields appear to arise mainly from two sources: the video display monitors on the dispatcher's console, and electrical wiring and equipment within the building.

Figure 8-2 shows the characteristics of the magnetic field near floor level at the dispatcher's seat. This is a plot from the vertical profile dataset MET046 contained in Appendix AP. The static field beneath the dispatcher's seat is seen to be elevated

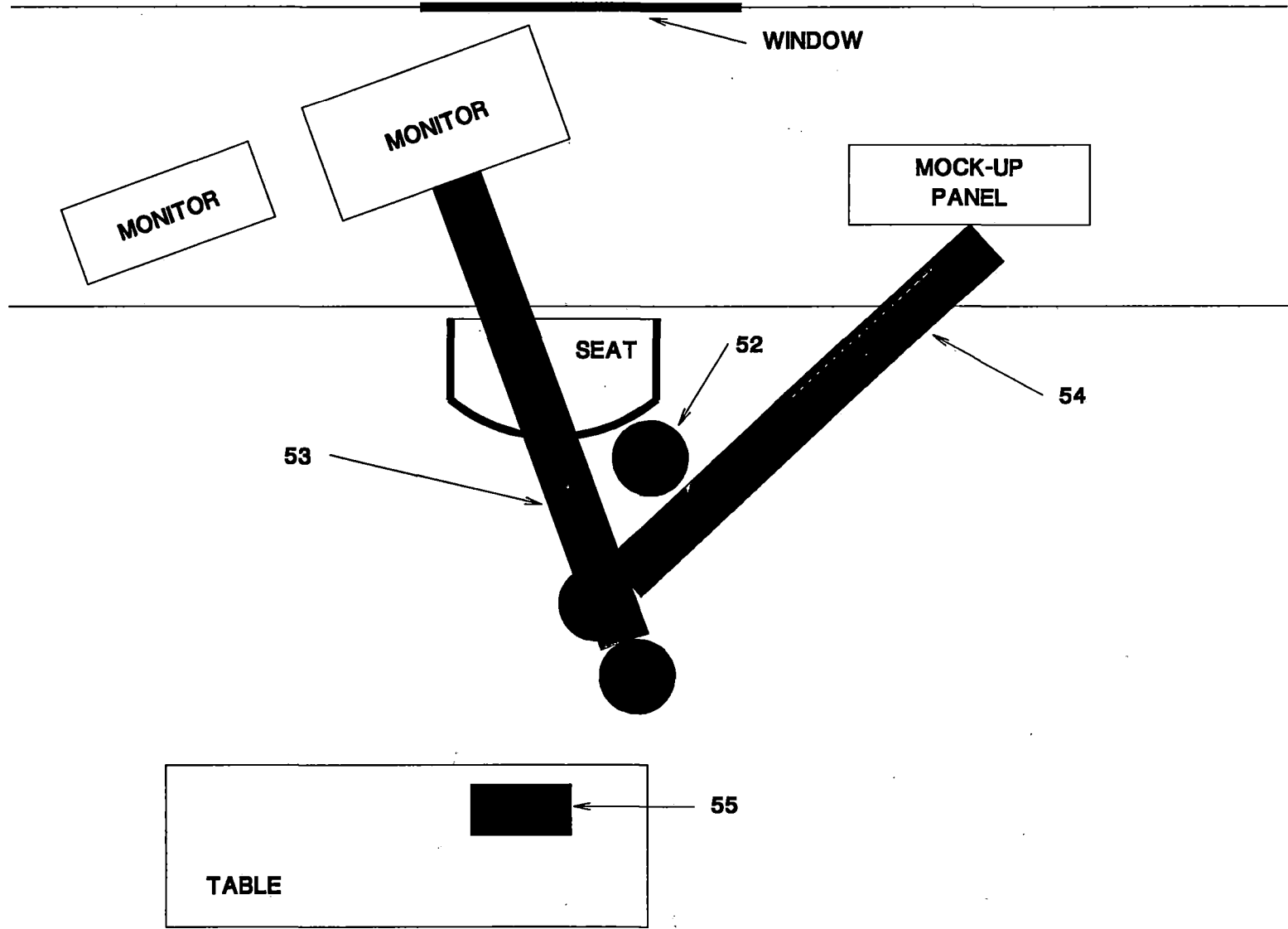

DISPATCHER'S ROOM AT SHADY GROVE

Figure 8-1 Repetitive waveform measurement locations inside the dispatcher's room at Shady Grove.

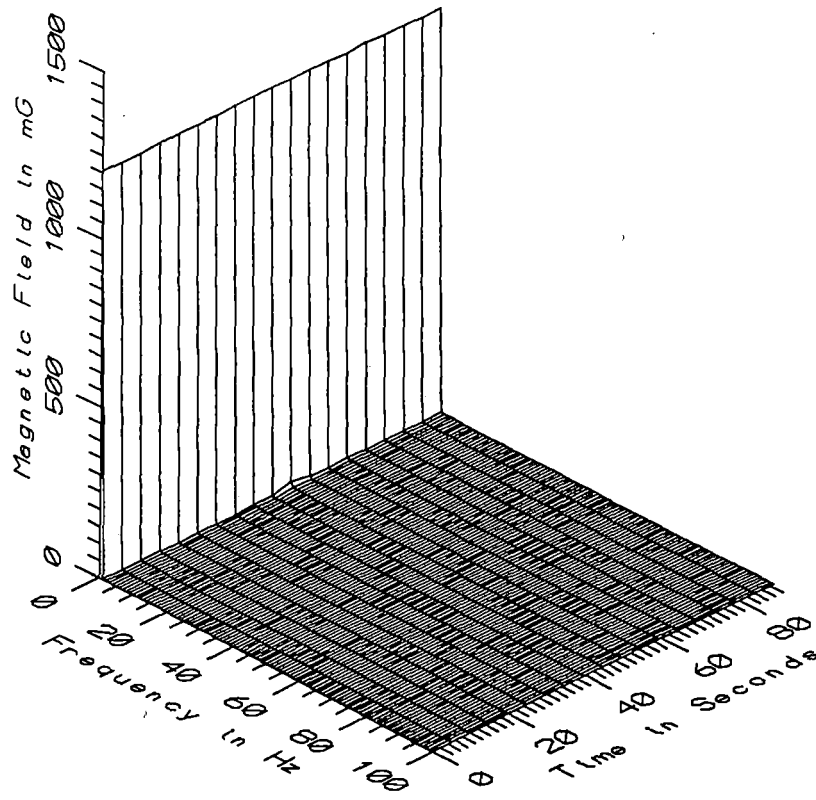

MET046 - 10cm ABOVE FLOOR AT SHADY GROVE DISPATCHER'S SEAT

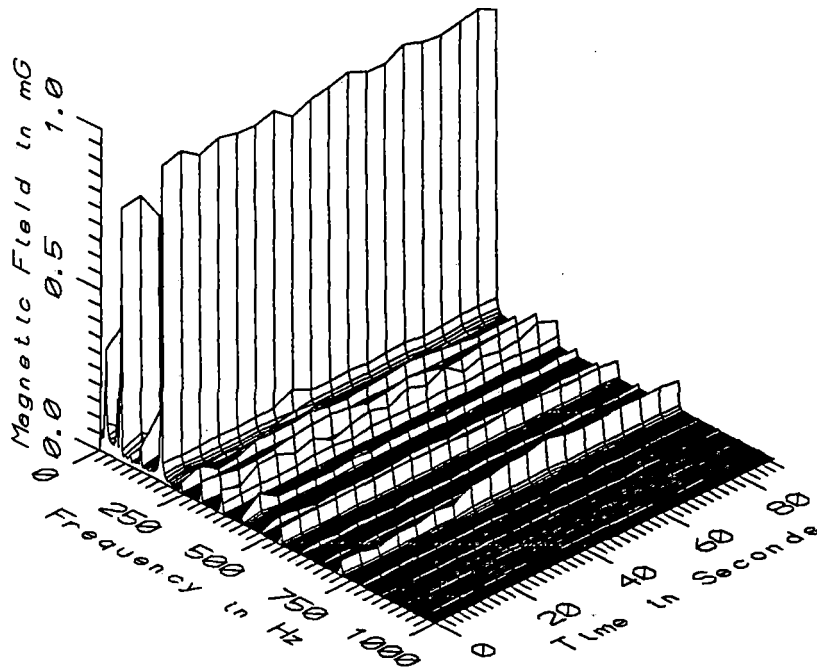

MET046 - 10cm ABOVE FLOOR AT SHADY GROVE DISPATCHER'S SEAT

Figure 8-2

Magnetic field level, with and without the static component, at 10 cm height above the floor by the dispatcher's seat inside the dispatcher's room at Shady Grove, as a function of frequency and time.

dc

well above the normal geomagnetic field level. The time varying field depicted in the lower frame of the figure is dominated by 60 and 180 Hz components, but every other harmonic of 60 Hz up to at least the twelfth is also present. The static and most time varying components are constant over time, but the sixth (360 Hz) and twelfth (720 Hz) harmonics vary over time in a correlated way. Those harmonics appear to arise from rectifier ripple in the third rail and track circuits which are present on both sides of the dispatcher's room. The static field at the dispatcher's seat decreases with increasing height above the floor as shown in the top frame of Figure 8-3 indicating that the field source is beneath the floor. Since the static field near the floor does not vary over time, it probably does not arise from dc traction current in the third rail or tracks. Possible sources include constant dc current in a circuit beneath the floor, residual permanent magnetism in a structural member beneath the floor, or perturbation of the geomagnetic field by a large ferromagnetic structure beneath the floor.

The bottom frame of Figure 8-3 shows that there is little variability of the intensity of the total time varying magnetic field in the vertical direction at the dispatcher's seat. That observation suggests that the principal magnetic field sources are either off to the side of the measurement staff or sufficiently far away that the field is essentially uniform over the length of the sensor staff. The video display monitor on the console in front of the dispatcher and the mockup panel to his front right are possible sources. Horizontal profiles of magnetic field at incremental distances from both devices were measured.

The characteristics of the magnetic field 10 cm in front of the video display monitor are shown in Figure 8-4 which comes from dataset MET047 in Appendix AQ. The top frame of the figure indicates an elevated static field level which is constant over time. The bottom frame shows the typical frequency spectrum of the vertical deflection field produced by the video display monitor. Attenuation profiles of the static and total ELF magnetic fields at increasing distances from the video display monitor are shown in Figure 8-5. The elevated static field attenuates rather slowly toward the natural ambient geomagnetic field level. The time varying magnetic field, on the other hand, decreases rapidly with distance away from the video display monitor. At 60 cm from the front of the monitor, the time varying field has decreased to a relatively uniform level of about 1 mG which persists for the remainder of the profile. A background field level of a milligauss or so is a typical value for the magnetic fields within buildings resulting from building wiring, lights, and other general equipment.

The mockup board was found not to be a significant source of magnetic fields.

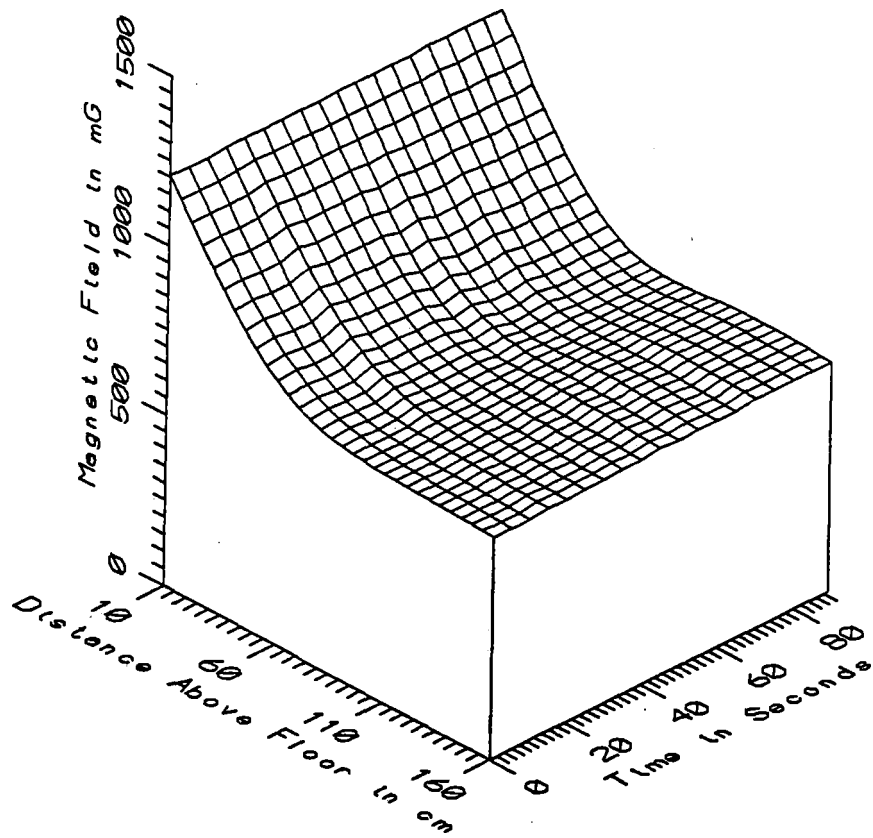

MET046 - SHADY GROVE DISPATCHER'S SEAT - STATIC

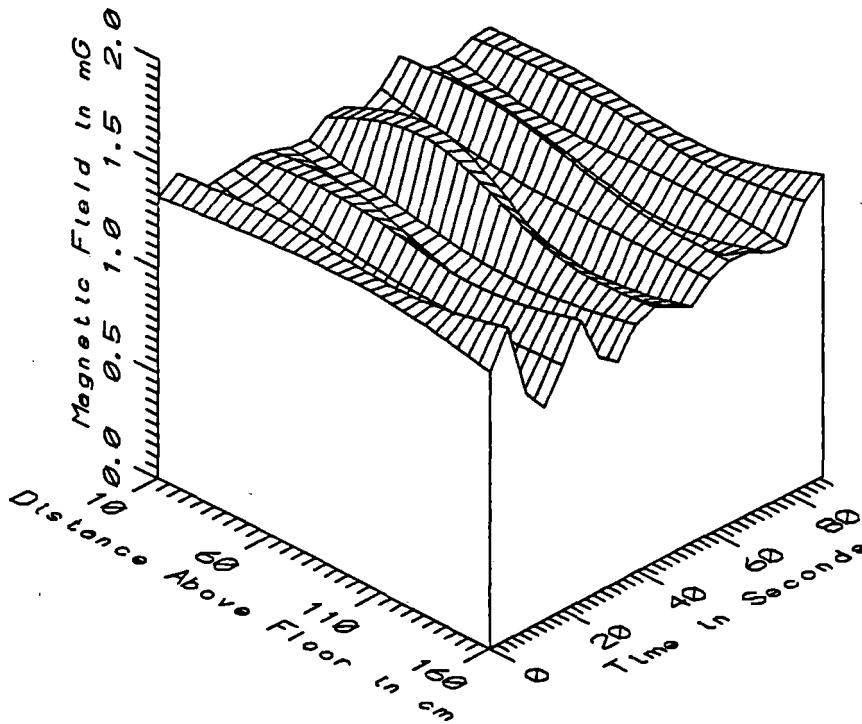

MET046 - SHADY GROVE DISPATCHER'S SEAT - ALL FREQ. 5-2560Hz

Figure 8-3

Magnetic field level versus height above the floor for the static and time varying (5-2560 Hz) components, at the dispatcher's seat inside the dispatcher's room at Shady Grove, as a function of time.

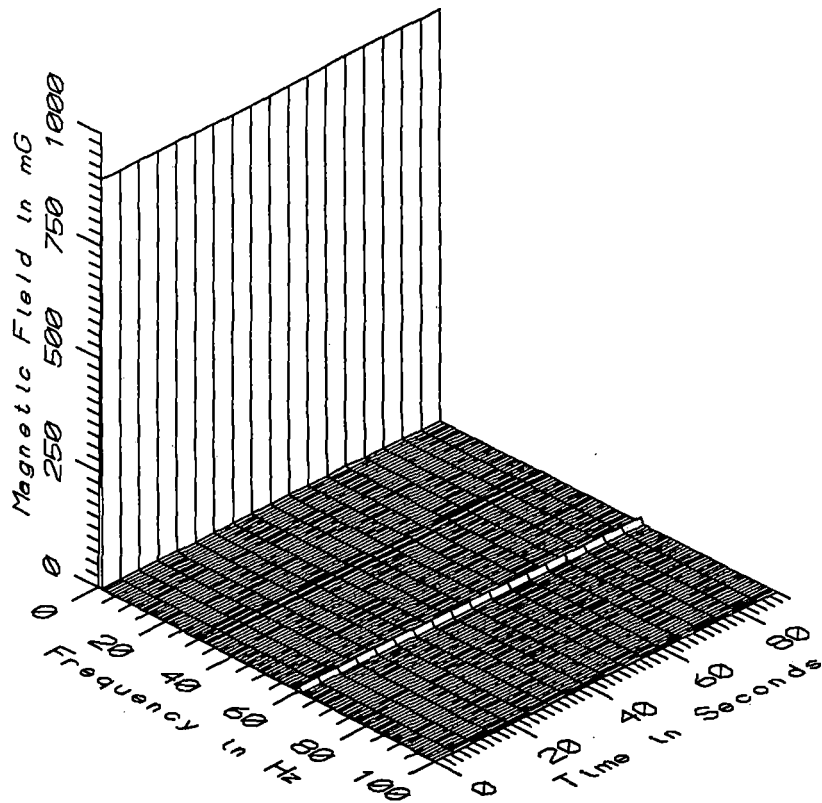

MET047 - 10cm FROM DISPATCHER'S MONITORS, 1.25M ABOVE FLOOR

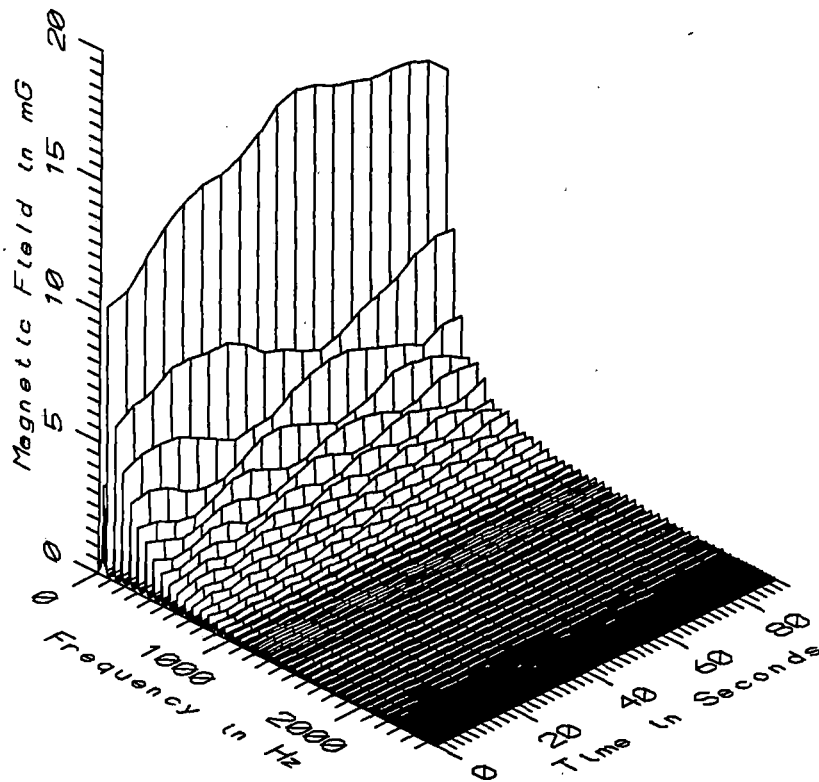

MET047 - 10cm FROM DISPATCHER'S MONITORS, 1.25M ABOVE FLOOR

Figure 8-4 Magnetic field level, with and without the static component, at 10 cm distance from the dispatcher's video display monitor and 1.25 meters height, inside the dispatcher's room at Shady Grove, as a function of frequency and time.

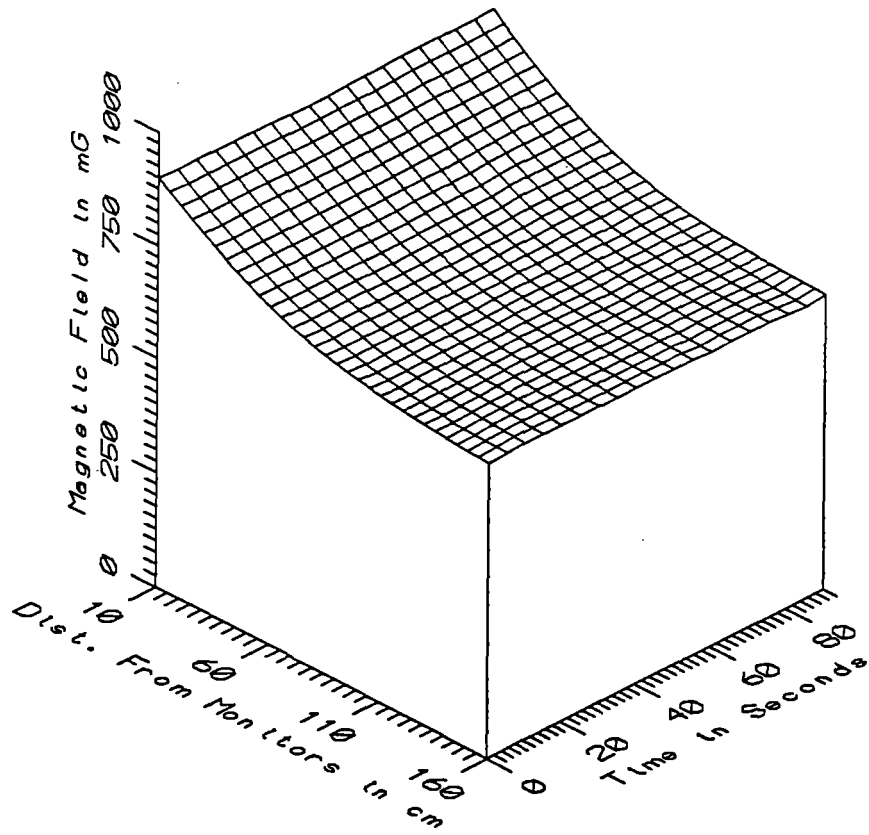

MET047 - IN DISPATCHER'S ROOM, 1.25M ABOVE FLOOR - STATIC

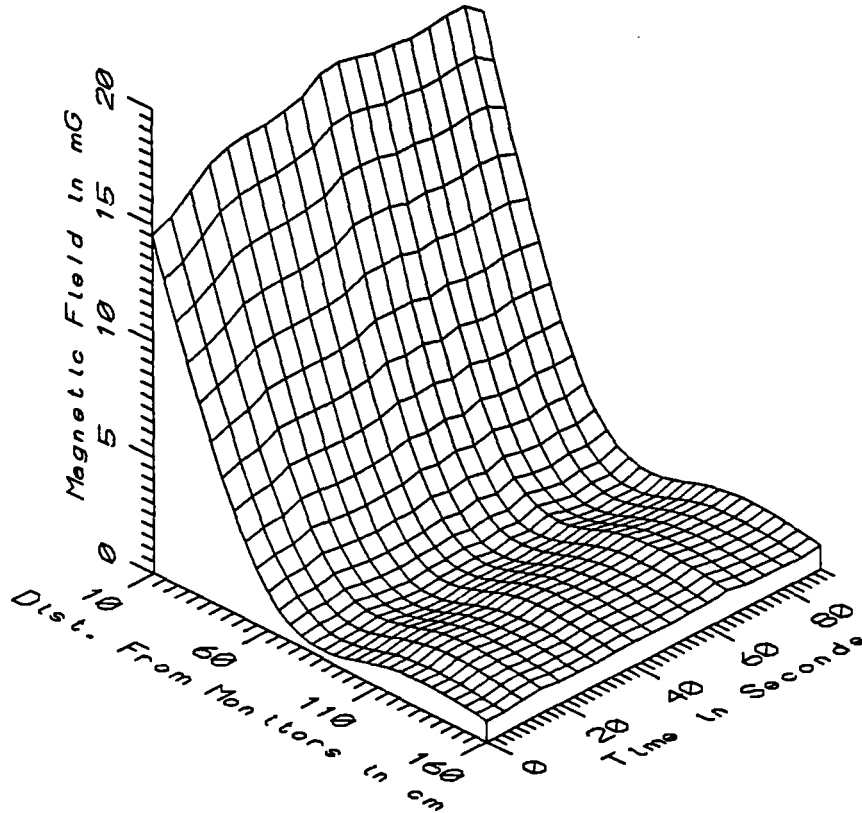

MET047 - IN DISPATCHER'S ROOM, 1.25M ABOVE FLOOR - ALL FREQ. 5-2560Hz

Figure 8-5 Magnetic field level versus distance from the dispatcher's video display monitor and 1.25 meters height for the static and time varying (5-2560 Hz) components, inside the dispatcher's room at Shady Grove, as a function of time.

8.4 DAT Waveform Data

A continuous recording of the magnetic field at the reference probe located on a table top behind the dispatcher's seat was made with the DAT while the vertical and horizontal profile measurements were being made. That recording is identified as Tape 2, Record 3 in Table 2-2. The record was scanned for transients or brief excursions in field level which were missed by the repetitive waveform sampling but nothing was found except for essentially constant field levels as measured with the *MultiWave*™ System and reported in Appendices AP through AR.

8.5 EMDEX-II Data

Both EMDEX data time course recordings while inside the dispatcher's room are presented here as Figure 8-6. These time course plots are from 11:11 to 11:17 hours on May 20, 1992. Table 8-1 shows the statistics for these recordings. As mentioned before, the researchers did wander about and placed the EMDEX-II against different equipment where high localized fields were found.

TABLE 8-1

STATISTICAL SUMMARY OF MAGNETIC FIELDS IN MG
RECORDED INSIDE THE DISPATCHER'S ROOM
USING EMDEX-II DATA RECORDERS

	AVERAGE	MAXIMUM
EMDEX #1	2.70 mG	55.80 mG
EMDEX #2	1.73 mG	12.20 mG
BOTH	2.22 mG	55.80 mG

8.6 Summary of Magnetic Field Levels

The major sources of ELF time varying magnetic fields in the vicinity of the dispatcher's seat are apparently the current in the building wiring, vertical deflection coils in the video display terminals, and power supplies for other electronic apparatus. Minor contributions from ripple currents in the Metrorail third rail and track circuits just outside the building are also detectable. The video display monitors and an unidentified source apparently below the floor of the building contribute to the static field levels near the dispatcher's seat. Appendices AP, AQ and AR contain the figures of the magnetic field plots for the Dispatcher's Room at Shady Grove as well as the summary statistics.

SHADY GROVE DISPATCHER'S ROOM

EmdexII Data From May20, 1992

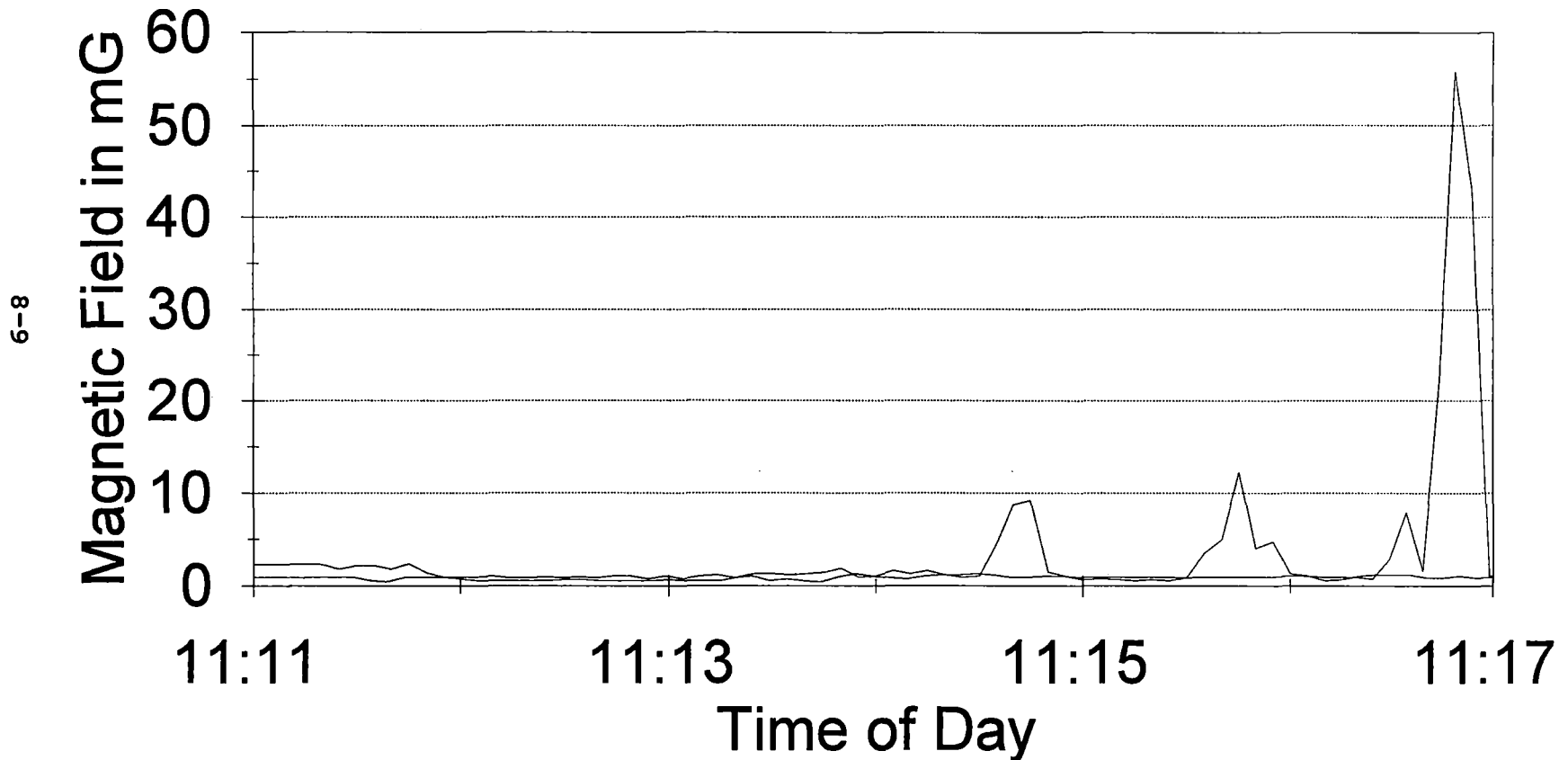

Figure 8-6

Magnetic field levels recorded inside the Shady Grove dispatcher's room using the EMDEX-II recorders, as a function of time.

Table 8-2, taken from Appendix AP, summarizes the field levels measured along a vertical profile at the dispatcher's seat. The table presents the minimum, maximum and average field levels, as well as the standard deviation and coefficient of variation. The results are summarized by the same set of five frequency ranges used throughout this report, and by the height above ground (or the distance from the monitor screen, as in the case of dataset MET047), given by the four sensor locations mounted on the staff. The elevated static field levels reported in the summary table are consistent with the 630 mG static field measurement made with the DAT above the table a few feet behind the dispatcher's seat but the average time varying field levels in the summary table (1.2 to 1.3 mG) are considerably smaller than the average field level found from EMDEX measurements (2.2 mG, Table 8-1). Much of that discrepancy seems to arise from the fact that the EMDEX recorders were occasionally used as survey meters and intentionally placed in high field areas. Figure 8-3 shows that throughout most of the EMDEX records, the time varying field level was between 1 and 1.5 mG.

8.7 Summary of Electric Field Levels

The graph of electric field level as a function of frequency and time measured 1.8 meters above the floor at the dispatcher's seat is shown in Figure 8-7. The field is very low, averaging approximately 0.5 V/m and consisting of components at 60 Hz and odd harmonics thereof. The highly variable low-frequency components are indicative of changes in static field level usually caused by the movement of nearby people who have some static charge on their clothing.

TABLE 8-2

STATISTICAL SUMMARY OF THE MAGNETIC FIELD LEVEL AT VARIOUS HEIGHTS ABOVE THE FLOOR INSIDE THE DISPATCHER'S ROOM AT SHADY GROVE (DATASET MET046)

MET046 - IN DISPATCHER'S ROOM AT DISPATCHER'S CHAIR				TOTAL OF 19 SAMPLES		
FREQUENCY BAND	HEIGHT ABOVE FLOOR (cm)	MINIMUM MAGNETIC FIELD (mG)	MAXIMUM MAGNETIC FIELD (mG)	AVERAGE MAGNETIC FIELD (mG)	STANDARD DEVIATION (mG)	COEFFICIENT OF VARIATION (%)
STATIC	10	1204.53	1218.24	1212.62	3.80	0.31
	60	739.08	788.72	758.94	14.83	1.95
	110	662.31	687.19	675.98	8.99	1.33
	160	644.72	674.94	660.16	10.60	1.61
5-45Hz LOW FREQ	10	0.26	0.61	0.35	0.09	24.70
	60	0.21	0.67	0.32	0.13	41.58
	110	0.10	0.35	0.16	0.07	44.27
	160	0.22	0.42	0.26	0.05	21.35
50-60Hz PWR FREQ	10	0.70	0.82	0.76	0.04	5.31
	60	0.23	0.81	0.60	0.17	27.79
	110	0.33	1.04	0.65	0.19	29.65
	160	0.39	0.96	0.69	0.19	27.03
65-300Hz PWR HARM	10	0.97	1.04	0.99	0.02	1.62
	60	1.02	1.10	1.06	0.02	2.25
	110	0.85	1.00	0.93	0.05	5.02
	160	0.84	1.06	0.94	0.07	7.24
305-2560Hz HIGH FREQ	10	0.13	0.19	0.16	0.02	11.32
	60	0.14	0.22	0.18	0.02	11.84
	110	0.16	0.25	0.20	0.02	10.51
	160	0.16	0.27	0.21	0.03	12.35
5-2560Hz ALL FREQ	10	1.25	1.43	1.31	0.05	3.56
	60	1.13	1.46	1.28	0.11	8.45
	110	1.00	1.41	1.17	0.12	10.65
	160	1.01	1.48	1.22	0.12	10.05

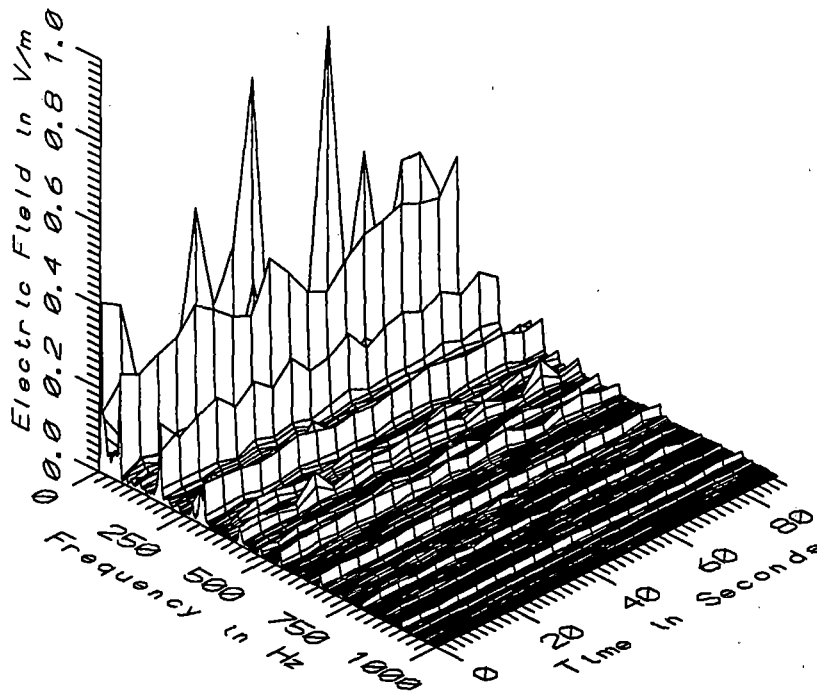

MET046 - ELECTRIC FIELD AT SHADY GROVE DISPATCHER'S SEAT

Figure 8-7

Electric time varying field level 1.80 meters above the floor, at the dispatcher's seat at Shady Grove, as a function of frequency and time.

9.0 CONCLUSIONS

Sections 3.0 through 8.0 of this report present the results of the analysis of extensive measurements taken on magnetic and electric fields within the cars and engineer's compartment, along the wayside, at passenger stations, near electric traction power supply stations and inside control facilities of the Metrorail System in the Washington, DC vicinity.

As described in these sections, the magnetic fields associated with the Metrorail System contain both static and time varying components. The dc traction current in the third rail, in the track return, in the power control equipment beneath the cars, and in the traction power supply station creates static fields in the vicinity of those facilities. The time varying magnetic fields associated with the Metrorail System are of two distinct types. First, changes in the "static" field level brought about by changes in the dc traction current in the aforesaid circuits produces low frequency time varying components that vary in intensity depending on the time rate of change of the static field. Secondly, there are periodic time varying components of the field arising from ripple in the dc traction current and from chopper current in the 3000 series cars.

Both static and time varying magnetic fields onboard the cars arise predominantly from the traction power control equipment beneath the floor and secondarily from the current loop formed by the third rail and the tracks. Because power needs of the cars are set by terrain and speed control, these fields are highly variable over time.

On station platforms, especially near the edge of the platform close to the rails, static and time varying magnetic fields arise both from the traction power (dc and rectification harmonics) and equipment onboard the passing trains. At the wayside locations the time varying magnetic fields also arise from rectification harmonics on the traction power however they were smaller than 60 Hz and harmonic fields from nearby power lines. Static field attributable to the Metrorail System could not be detected because they were smaller than the natural static field of the earth. Magnetic fields from equipment onboard the passing train were not found at the wayside location.

At traction power supply stations, measurements at the sides close to the ac electric equipment such as transformers and switchgear, yield 60 Hz and odd harmonic (mainly third harmonic) fields. At the dc, or output, side of the station, magnetic fields have the combined characteristics seen at the ac side of the station plus the static field and ripple-frequency fields seen at other places near the Metrorail tracks.

No significant electric fields were detected anywhere in the system. The largest fields, of the order of 7 V/m were found outside one electric traction power supply stations but appeared to arise from a nearby distribution line rather than the station. Along the wayside the fields measured approximately 5 V/m and in the passenger stations 2 V/m. As expected, electric fields of less than 1 V/m were detected inside the cars and the dispatcher's office, because of the shielding by the cars and the building structures. The predominant frequency of these fields was 60 Hz which indicates that the source was either nearby electric equipment or nearby electric distribution lines.

9.1 Summary of Metrorail Field Levels

This subsection provides a concise description of the magnetic field characteristics at each of the areas examined. As noted above, all measured electric fields were less than ten volts per meter (10 V/m) and did not appear to originate from the Metrorail transportation system or equipment.

9.1.1 Cars

The magnetic fields in the passenger areas of the Metrorail cars arise mainly from the traction power control equipment beneath the floor of the cars and also possibly the current in the loop created by the third rail and track return circuit. These fields are predominantly static with low frequency time varying components resulting from fluctuations in the static field level. However, large time varying magnetic fields are found near the center of the 3000 series cars which use 273 Hz semiconductor choppers to control the amount of electric power supplied to the traction motors. This central area of the 3000 series cars has a unique magnetic field environment in that both the static and time varying fields are much larger, especially near the floor, than the rest of the cars. The source is probably the large filter (smoothing) reactor coil under the center of the 3000 series car.

The static magnetic field at seat level (60 cm above the floor) in these dc powered Metrorail cars, excluding the central area of the 3000 series cars, averaged 1026 mG. The maximum static field encountered at seat height for the same samples was 4539 mG. The corresponding average and maximum dc fields 60 cm above the floor in the center of the 3000 cars are 2685 mG and 23,732 mG, respectively.

The total time varying magnetic field levels averaged 12 mG over all samples and all sensor locations, except the center of the 3000 cars. The maximum time varying field encountered during the same periods was 65 mG. However, on the center of the 3000 series cars, the corresponding average and maximum

time varying magnetic fields are 317 mG and 2987 mG respectively.

9.1.2 Engineer's Compartment

The principal sources of magnetic field in the engineer's compartment are the same as in the passenger areas, that is, the traction power equipment beneath the floor and possibly the current in the loop created by the third rail and the track return circuit. There appeared to be no additional sources unique to the engineer's compartment. As described in Section 9.1.1, these fields are predominantly static with low frequency time varying components resulting from fluctuations in the static field level. The measurements made onboard the three different types of cars are comparable to one another. Thus, an overall set of statistics is possible. The following summary values were obtained close to the engineer's seat.

The static magnetic field, as measured by the *MultiWave*™ System, averaged 761 mG at seat level (60 cm height). The maximum static field encountered for the same 60 cm height was 3148 mG.

The total time varying magnetic field levels averaged 11 mG at the 60 cm height level and the maximum field encountered was 24 mG.

9.1.3 Metrorail Waysides

The static magnetic field at the wayside of the Metrorail line arises from a combination of the earth's magnetic field and the static magnetic field due to the dc traction current in the rails. At locations outside the right-of-way exclusion fence, the static field from traction current in the third rail and tracks does not add appreciably to the natural static field environment. The time varying field at the wayside has components from three sources: changes in the dc traction current produce low frequency components whose magnitude depends on the rate of change of the dc current; second from the rectifier ripple currents in the rails and third from the 60 Hz current in any nearby commercial power lines. Since the magnetic field at the railroad wayside due to the current in the rails attenuates (becomes weaker) rapidly with distance from the tracks, at distances comparable to the exclusion fence location, the time varying field from common sources such as distribution lines equal or exceed the components from the Metrorail System.

The average value of the dc field measured at the wayside was 559 mG, which compares with the published value of 543 mG for Washington, DC. The largest dc value measured at the wayside

was 733 mG. The average and maximum ac magnetic fields measured at the right-of-way exclusion fence were 7.01 mG and 7.45 mG respectively but those values are dominated by fields from nearby powerlines. The average and maximum fields actually arising from the Metrorail System are estimated to be 0.8 mG and 1.3 mG respectively.

Measurements beneath a Metrorail overpass found the average and maximum static field levels to be 485 mG and 566 mG with trains passing overhead. The measured average and maximum time varying field levels were 1.0 mG and 1.8 mG but those values included fields apparently arising from nearby powerlines. The estimated average field from the Metrorail System was 0.4 mG with a maximum value of 1.6 mG.

The electric fields measured at the open space along the wayside were under 5 V/m.

9.1.4 Passenger Station Platforms

The magnetic field environment on a passenger station platform is similar to the wayside, except that the rider is closer to the rails. Static fields from traction power current in the third rail and track return circuit add to the naturally occurring geomagnetic field. The time varying magnetic field at the platforms arises from changes in the static (dc) component due to changing dc traction power in the rails, the rectifier harmonics in the rails and fields from the passing cars themselves. Moreover, there are 60 Hz fields from nearby electric equipment, such as station wiring, lights, and escalator motors.

The average values of the static field measured at body torso height (110 cm above the floor) near the edge of the outdoor and underground station platforms were 433 mG and 400 mG respectively. The maximum value measured on the outdoor platform where 3000 series cars were operating was 1218 mG at torso height but near floor level, a maximum static field level of 3270 mG was recorded for a brief instant as a 3000 series car passed eighteen inches from the sensor. The maximum static field levels were substantially lower on the platform of the underground station. That difference is perhaps because 2000 series cars were passing the station rather than the 3000 series cars which produced the large maximum fields at the outdoor station.

The average and maximum time varying magnetic fields measured 110 cm above the edge of the outdoor platform were 2.3 mG and 22.7 mG respectively. The corresponding values for the indoor platform were 1.2 mG and 10.0 mG. The difference in maximum field levels was in this case clearly due to the difference in types of cars operating at the two stations.

The electric fields measured on any of the platforms were under 5.2 V/m.

9.1.5 Traction Power Supply Stations

Only modest strength magnetic fields were observed outside the traction power supply stations. The largest measured static value was 1676 mG at a distance of 10 cm from the station wall. That static field was very localized and it decreased by 35% at a point 50 cm farther from the wall.

The average time varying magnetic field measured 10 cm from the fence or wall at eight locations around two stations was 4.7 mG, however there was considerable variation in field levels from one location to another. The average and maximum field 10 cm from the wall at the six locations with the lowest fields (apparently near the ac portion of the station) were 2.7 mG and 8.3 mG respectively. The two locations where the time varying fields were higher were presumably near the dc output portion of the station from the field frequency spectra. The average and maximum time varying magnetic fields at those locations were 6.4 mG and 21.1 mG respectively.

The highest electric field measured at any of the stations was under 7 V/m and that field apparently came from a nearby distribution line rather than the traction power supply station.

9.1.6 Control Facilities

The major sources of magnetic fields in the dispatcher's area are the current in the building wiring which supplies power to the equipment and lights, and the equipment itself, such as video display terminals (VDT). The measured average and maximum ac magnetic fields in the dispatcher's room were 1.2 mG and 1.5 mG. Higher values were found close to equipment. The static field in the dispatcher's room was constant over time but varied from 1210 mG near the floor to 660 mG at 160 cm above the floor.

The electric fields measured at inside the dispatcher's room were under 1 V/m.

9.2 Environmental Magnetic Field Levels

The predominant source of static field in the environment is the earth's geomagnetic field. The unperturbed geomagnetic field intensity varies over the surface of the earth from roughly 240 mG to 670 mG. The geomagnetic field level in the vicinity of Washington, DC is approximately 543 mG. The presence of iron and steel components in buildings, vehicles, and structures perturbs the geomagnetic field in the vicinity of those objects making the

geomagnetic field intensities routinely encountered by people somewhat more variable. Static field levels ranging from 200 mG to 1000 mG are frequently found in such areas.

Permanent magnets also represent localized sources of high intensity static magnetic fields. A child's toy magnet may have a flux density of several hundred to a few thousand gauss at its pole. Ferrite permanent magnets imbedded in seals and weatherstrips around refrigerator doors and home or office doors and windows are frequently encountered, providing static fields of a few gauss at the portal.

The overwhelmingly predominant source of ELF magnetic fields in the environment is the 50 or 60 Hz magnetic field produced by virtually all equipment or facilities which generate, distribute, or utilize electric power. Due to the electrification of our modern society, power frequency (60 Hz in North America, 50 Hz in Europe) magnetic fields are ubiquitous. Numerous authors have reported environmental levels of power frequency magnetic fields for specific situations. Nair, et al.,⁵ provides a summary of that information as well as useful insight into the parameters which affect power frequency magnetic fields. Figure 9-1 shows the range of power frequency magnetic field levels which may be found at various distances from three important sources of magnetic field.

Power frequency magnetic fields in American homes arise primarily from three sources: outdoor power lines; house wiring; and household appliances. Field levels for power lines and appliances are summarized in Figure 9-1. Field levels from house wiring differ greatly from home to home. The total power frequency magnetic fields in homes is typically about 0.7 mG^{5,8} at the center of each room but can vary substantially from room to room or home to home. Magnetic field levels in excess of 10 mG at the center of a room are atypical but not uncommon.

Power frequency magnetic field levels in the workplace are highly variable. In offices and most commercial establishments, the power frequency magnetic field environment is similar to or somewhat higher than that in homes. But in certain industrial settings, considerably higher ELF magnetic field levels are encountered. Unfortunately, field characterization in the workplace is limited to a small number of measurements which lack validity as indicators of "typical" or "overall" estimators of workplace magnetic field levels.

These common environmental sources of ELF magnetic field are predominantly power frequency field sources. Magnetic fields near power lines and substations may have low order harmonic components, but these are generally only a small percentage of the fundamental power frequency component. The harmonic content of residential and most workplace magnetic fields is also generally quite low, but

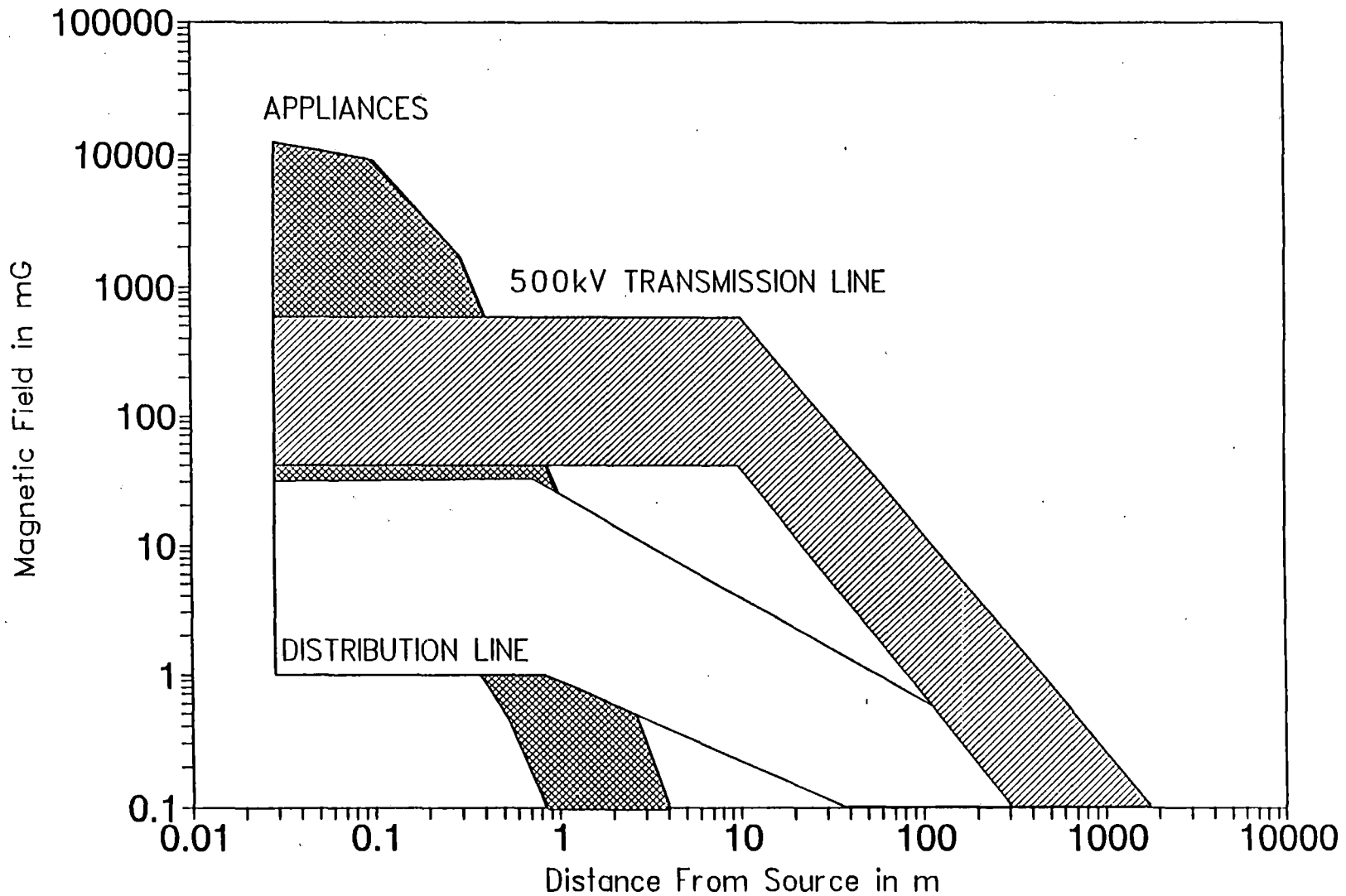

Figure 9-1

Illustration of how the magnetic field intensity at ground level changes with horizontal distance from three common sources of power-frequency magnetic fields. The bands represent variation across individual sources in each group. Adapted from Nair, et al.⁵

on occasion can become a significant part of the total field. High harmonic content appears most frequently in magnetic fields near appliances containing non-linear electrical load control devices. Figure 9-2 shows a field by frequency and time plot for the magnetic field produced by a triac-controlled vacuum cleaner. Although the harmonic content is relatively large, only the lower order harmonics have significant amplitude. Essentially, no energy is present at frequencies below the power frequency. This is characteristic of the magnetic fields produced by many appliances with electronic controls.

Televisions and computer video display units which make use of magnetic deflection are the most commonly encountered source of ELF magnetic fields at frequencies other than the power frequency. Vertical deflection frequencies for these devices are generally in the 55 to 75 Hz range; however, the magnetic fields are rich in harmonics. Horizontal deflection frequencies and their associated fields are well above the ELF range.

Other significant sources of non-power-frequency ELF magnetic fields are headphones and telephone receivers which produce relatively intense voice-frequency magnetic fields in the vicinity of the user's ear. However, these fields attenuate quickly with distance from the earpiece. Certain pieces of industrial and medical equipment also produce relatively large ELF magnetic fields at frequencies other than 50 or 60 Hz, but they are rarely encountered by the general public.

ELF electric fields in the environment arise most frequently from unshielded equipment or facilities used to generate, distribute, or utilize electric power. Like ELF magnetic fields, these electric fields have the frequency of the electric power system: 60 Hz in North America and 50 Hz in Europe. Since ELF electric fields are easily shielded by materials with even modest electrical conductivity, the predominant sources encountered by the general public are overhead electric power transmission and distribution lines, home or office electrical appliances and some electric lights. Nair, et al.,⁵ provide a discussion of environmental electric fields well summarized by Figure 9-3, which is extracted from their report.

9.3 Comparison of Metrorail Fields to Other Electro-technologies

Much of the concern about ELF magnetic field levels is driven by uncertainty as to whether such fields exert an adverse effect on human health. Existing scientific knowledge provides no sound insight as to what aspects of ELF magnetic exposure, if any, are of biological concern⁵. Consequently, public acceptance of magnetic field exposures is presently based more on equity and comparability to other exposures than it is to quantifiable characteristics of the field itself. Therefore, this section compares and contrasts

6-6

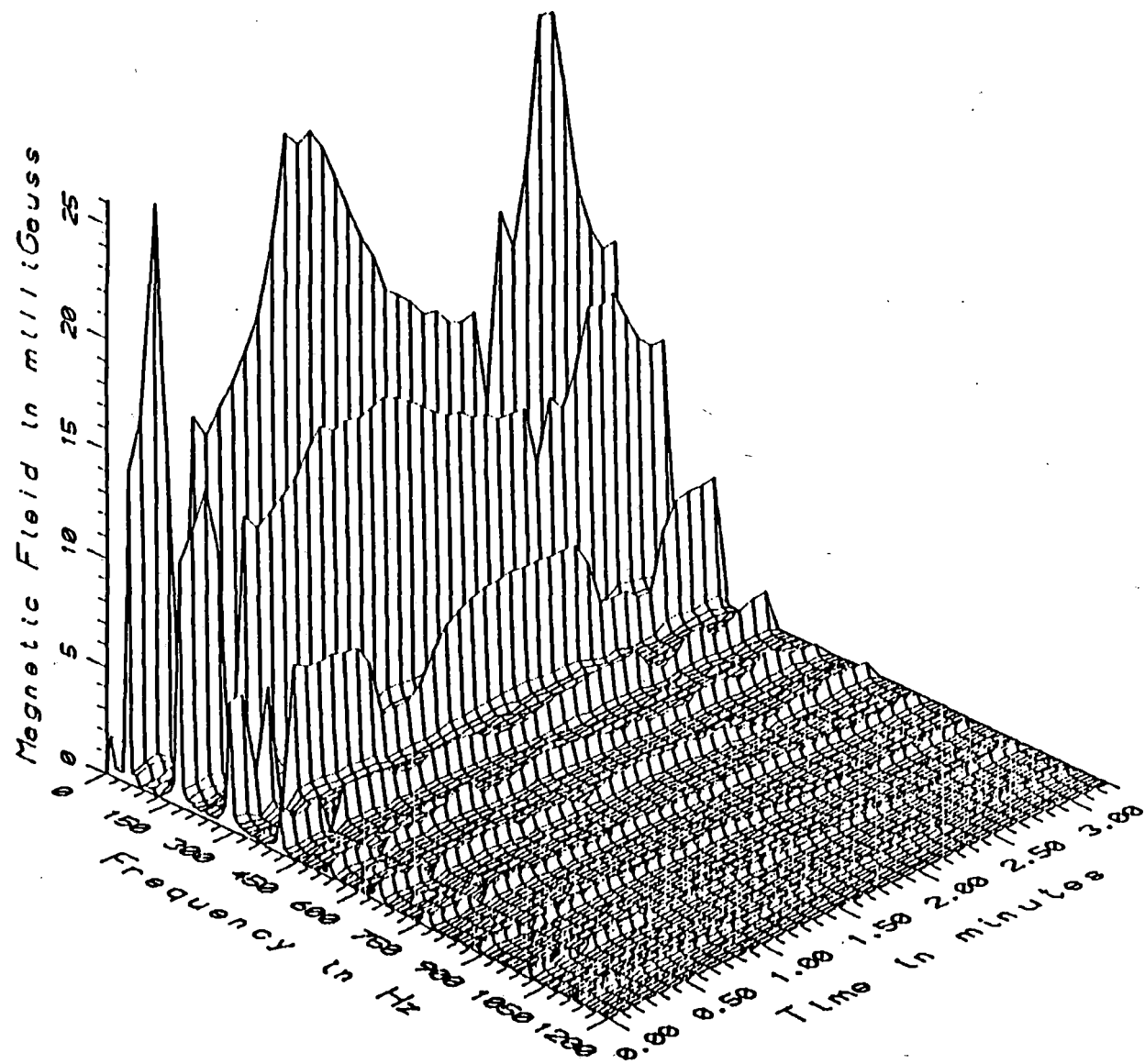

Figure 9-2 Magnetic field 30 cm from a shop vac.

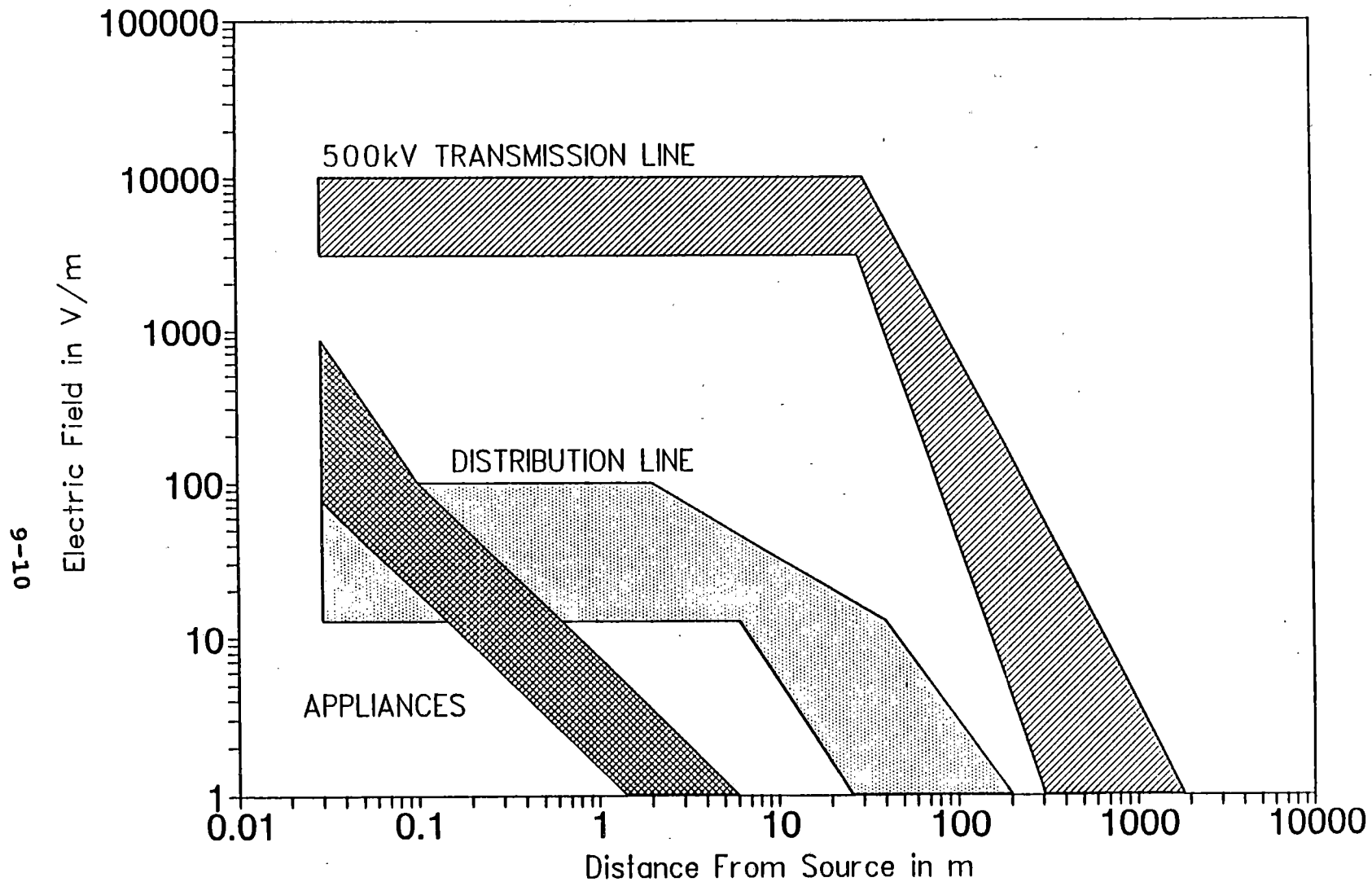

Figure 9-3 Illustration of how electric field intensity near ground level will change with horizontal distance from three common sources of power-frequency electric fields. The bands represent variation across individual sources in each group. Adapted from Nair, et al⁵.

the magnetic fields produced by the Metrorail operation to other sources of magnetic fields.

9.3.1 Static Fields

Static magnetic fields beyond ^{the ?} normal range normally due to passive perturbation of the earth's geomagnetic field exist inside the cars, the engineer's compartment, at the wayside, on the platforms and outside the traction power supply stations because of the very nature of the Metrorail electrification. The largest measured static fields were encountered at the center of the 3000 cars, near the floor. The maximum magnetic field reading 10 cm above the floor was 131.5 gauss at that point and the average was 14.3 gauss. That is an extreme example but total static fields in excess of one gauss occasionally existed at many measurement locations.

9.3.2 Frequency Spectrum

The frequency characteristics of the magnetic fields onboard or near the Metrorail cars is substantially different than those near many electrical appliances. The dc electrification gives rise to low frequency components which are the result of temporal changes in the dc traction current drawn by operating cars. Also, there are even harmonics of 60 Hz present that arise from the rectification ripple currents in the traction current. Moreover, the 3000 series cars contain semiconductor choppers and a filtering reactor coil, located beneath the middle of the car, which produce significant fields in the higher end of the ELF band.

9.3.3 Time Characteristics

The magnetic fields onboard the Metrorail cars or near the rails have pronounced temporal variability similar to the variability of magnetic fields near appliances with varying load or intermittent use. These fields have much greater variability than the fields found near most commercial electric power lines.

9.3.4 Amplitude Characteristics

This subsection compares the measured field levels onboard the Metrorail cars or near the Metrorail line and its facilities to the reported environmental field levels from various power frequency sources. This comparison is based on total ELF magnetic field and does not take into consideration the significant differences in frequency spectra. For considerations where frequency is an important factor, this comparison is invalid because Metrorail System fields which

contain little or no 60 Hz component are compared to fields which are essentially entirely 60 Hz.

9.3.4.1 Cars

Figure 9-4 shows the general range of total time varying magnetic fields measured in the cars on the Metrorail train as a function of distance from the source which for purposes of this graph is presumed to be the car floor. The range is plotted over the graph of a typical distribution line and appliance field levels⁵ discussed earlier. As the graph illustrates, the intensity of the ELF magnetic field inside the cars diminishes away from the floor, but exhibits an increase towards the ceiling. The range of magnetic field intensities spans more than three orders of magnitude, including the range of magnetic fields found under all distribution lines and some transmission lines. However some higher intensities are found in transmission lines and close to appliances.

Figure 9-5 shows the range of total time varying magnetic fields measured in the center of the 3000 series car on the Metrorail train as a function of distance from the source (car floor). The central area of the 3000 series cars exhibits much larger static and time varying fields, especially near the floor. The source under the car is probably the large filter reactor coil in the midpoint of the 3000 series cars. The range of magnetic field intensities overlaps both the transmission line and appliances plots, that is, the intensities are as high as transmission lines and appliances.

9.3.4.2 Engineer's Compartment

Figure 9-6 shows the range of total time varying magnetic fields recorded in the Metrorail engineer's compartment as a function of distance from the catenary. The data are plotted over the same typical power frequency magnetic field levels. The magnetic field levels in the engineer's compartment are similar to those found in other parts of the cars (see Figure 9-4) and are within the range of field levels found beneath electric distribution lines or near appliances.

9.3.4.3 Along the Wayside

Figure 9-7 shows the plot of the ranges corresponding to the two measurement locations, namely the underpass and the open space along the wayside. The distance to the source for the underpass is measured to the rails above. The distance for the open space is measured to the

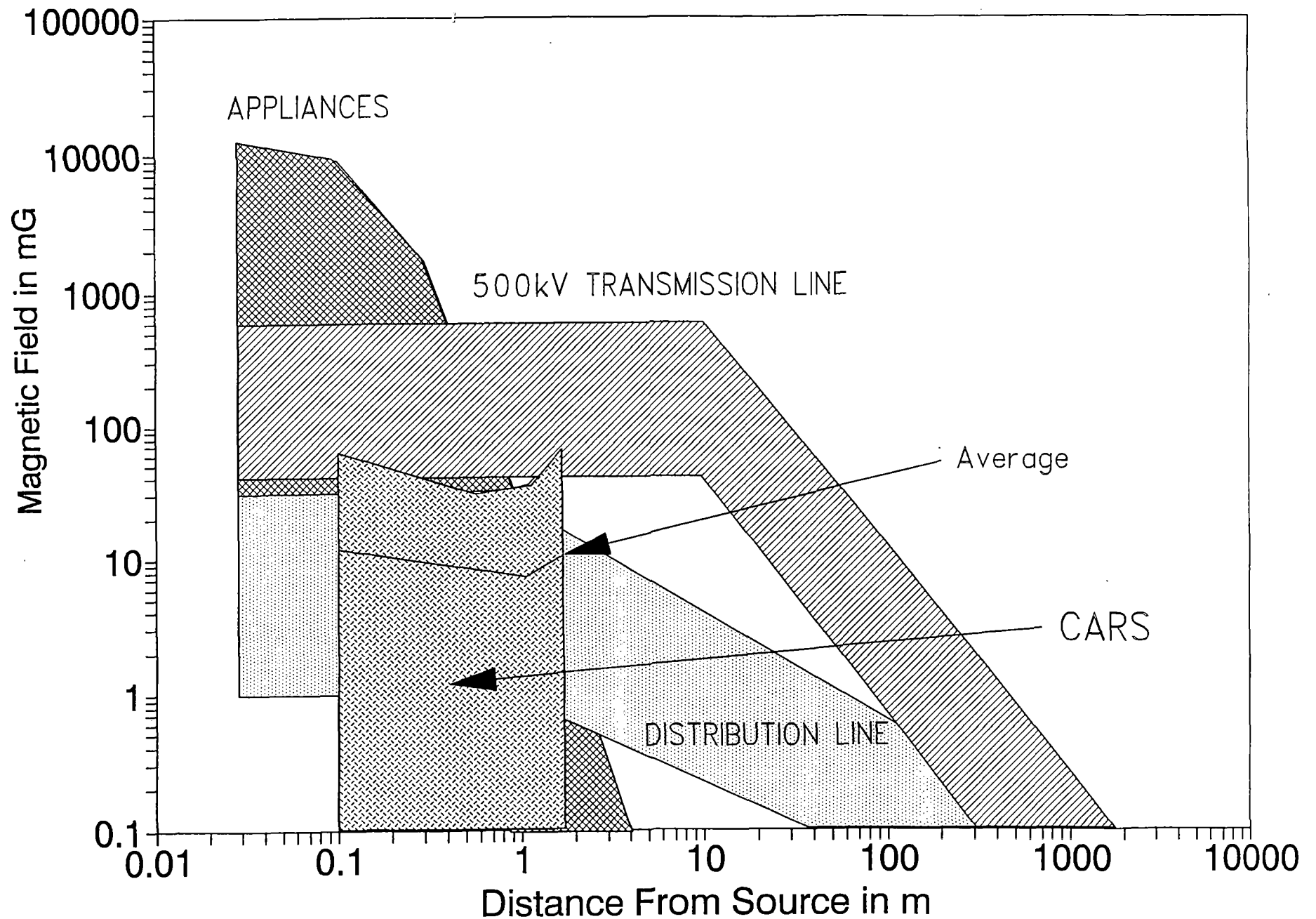

Figure 9-4 The range of total time varying magnetic field levels in the Metrorail cars compared to typical levels of power frequency magnetic fields produced by common sources.

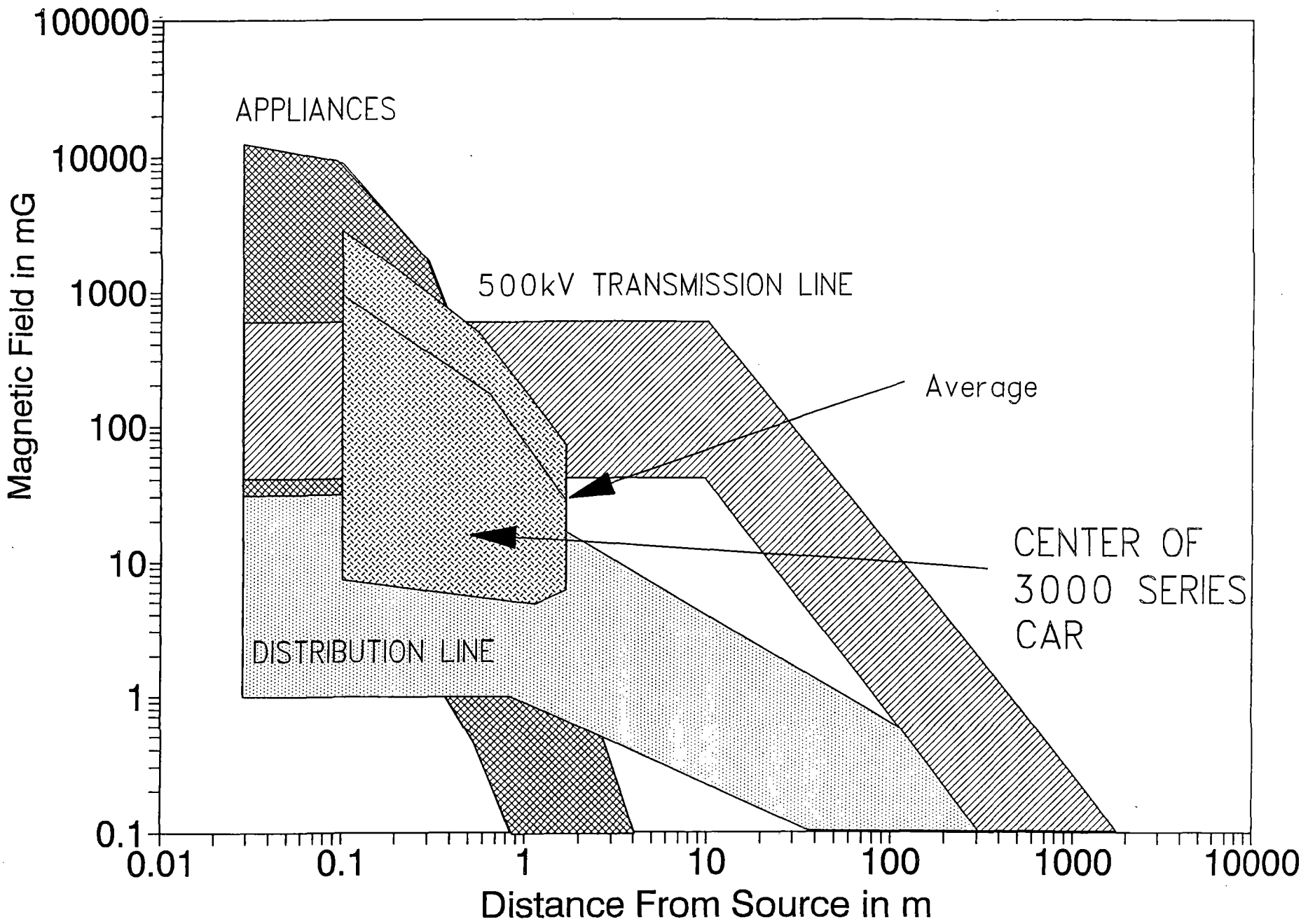

Figure 9-5 The range of total time varying magnetic field levels in the center of the 3000 series Metrorail cars compared to typical levels of power frequency magnetic fields produced by common sources.

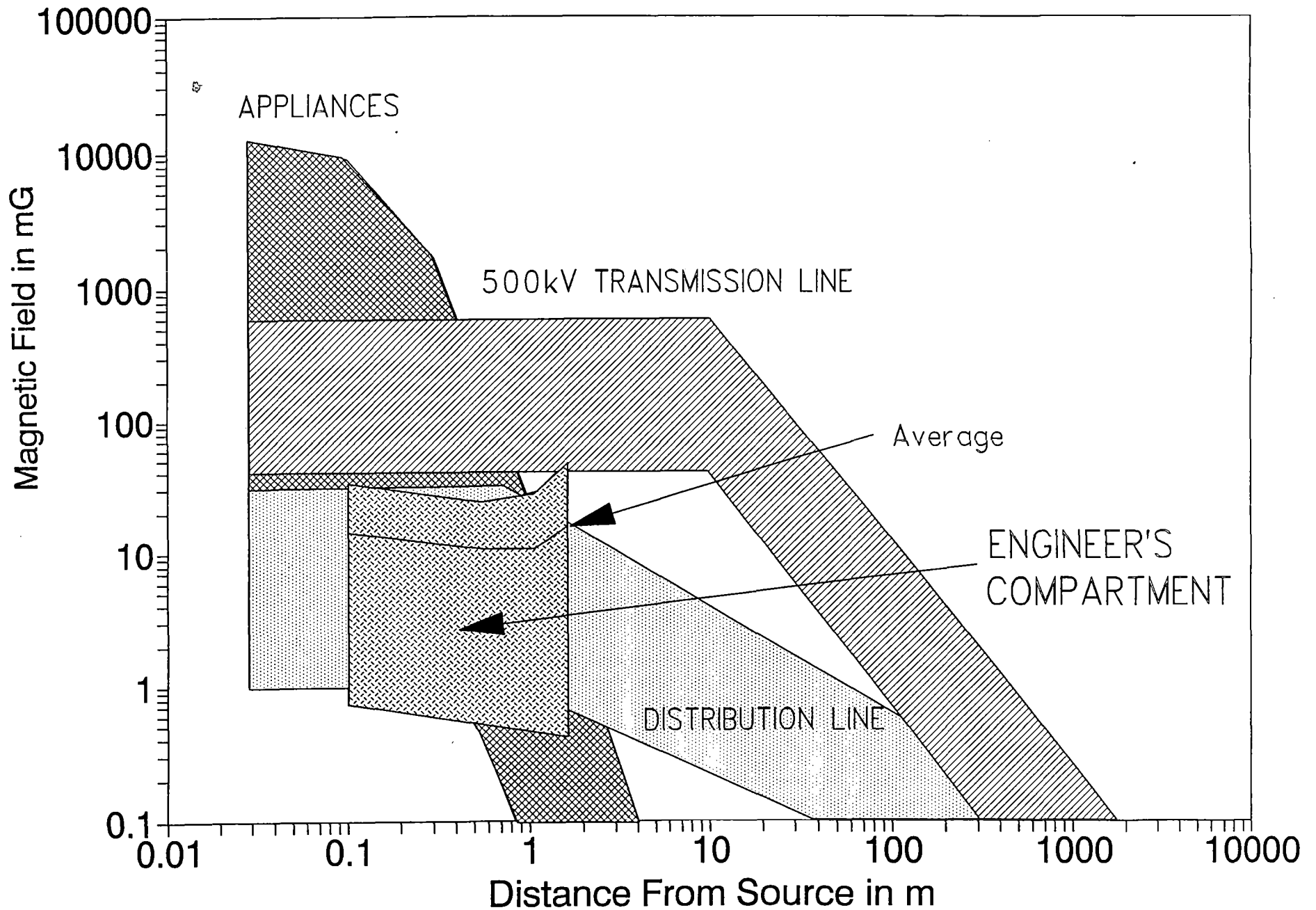

Figure 9-6 The range of total time varying magnetic field levels in the engineer's compartment of the Metrorail cars compared to typical levels of power frequency magnetic fields produced by common sources.

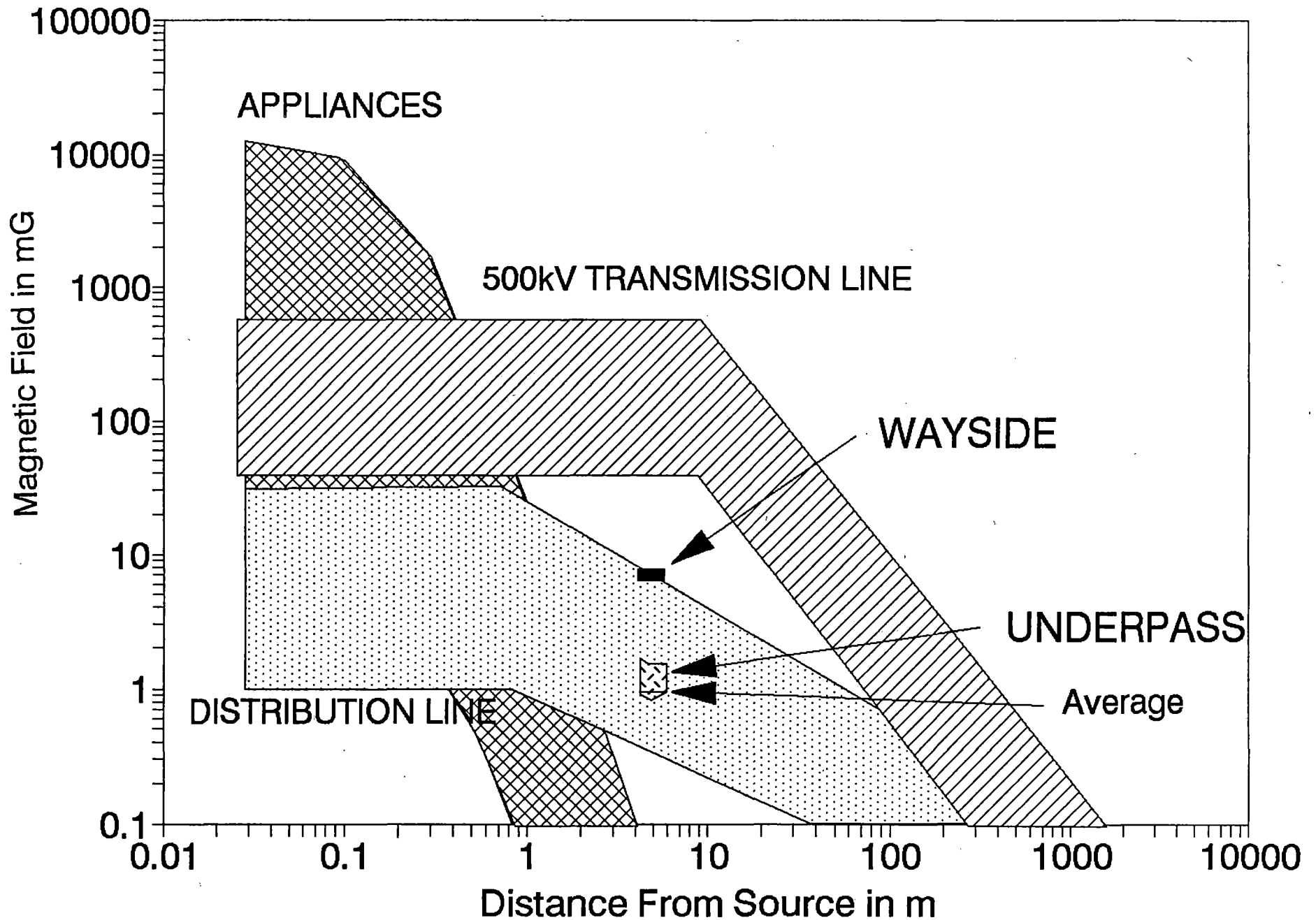

Figure 9-7

The range of total time varying magnetic field levels at a wayside and a highway underpass, at various distances from the nearest fence or track, compared to typical levels of power frequency magnetic fields produced by common sources.

nearest set of tracks. As described in Section 6, these measured field levels included fields from both the Metrorail System and background fields from other sources. Consequently, the measured values overstate the magnitude of the field actually produced by the Metrorail System. The figure shows that these conservative measures of magnetic field levels at both locations are within the general range of magnetic fields near distribution lines. The actual fields from the Metrorail facilities are actually lower.

9.3.4.4 Passenger Stations

The ranges of time varying magnetic fields measured on the Grosvenor outdoor and Gallery underground transfer passenger stations are shown in relation to other sources in Figure 9-8. The distance to the source is the distance to the edge of the platform. The range of magnetic field levels at the platforms are slightly less than the general range of magnetic fields near distribution lines.

9.3.4.5 Power Supply System Measurements

The range of total time varying magnetic fields recorded at eight locations outside two different electric traction power supply stations is shown in Figure 9-9. It can be seen that these field levels are in the range of fields found under distribution lines. The distance to the source is the distance to the fence or wall of the installation.

9.3.4.6 Control Areas

Figure 9-10 shows the plot of the range of time varying magnetic fields in front of the dispatcher's VDT in the dispatcher's room. The distance to the source is the distance to the VDT screen. As one would expect, the figure shows that the range of magnetic field levels from the VDT is well within the range of magnetic fields near appliances. The flat part of the VDT field curve beyond 1 meter from the source represents the general background field level within the dispatcher's room. That background level is very modest compared to the range of field levels found near the three common field sources depicted in the figure.

9.4 Comparison of Metrorail Fields to Existing Standards

The United States has no national standards which establish limits on the intensity of ELF electric magnetic fields. There are two guidelines established by international organizations and one

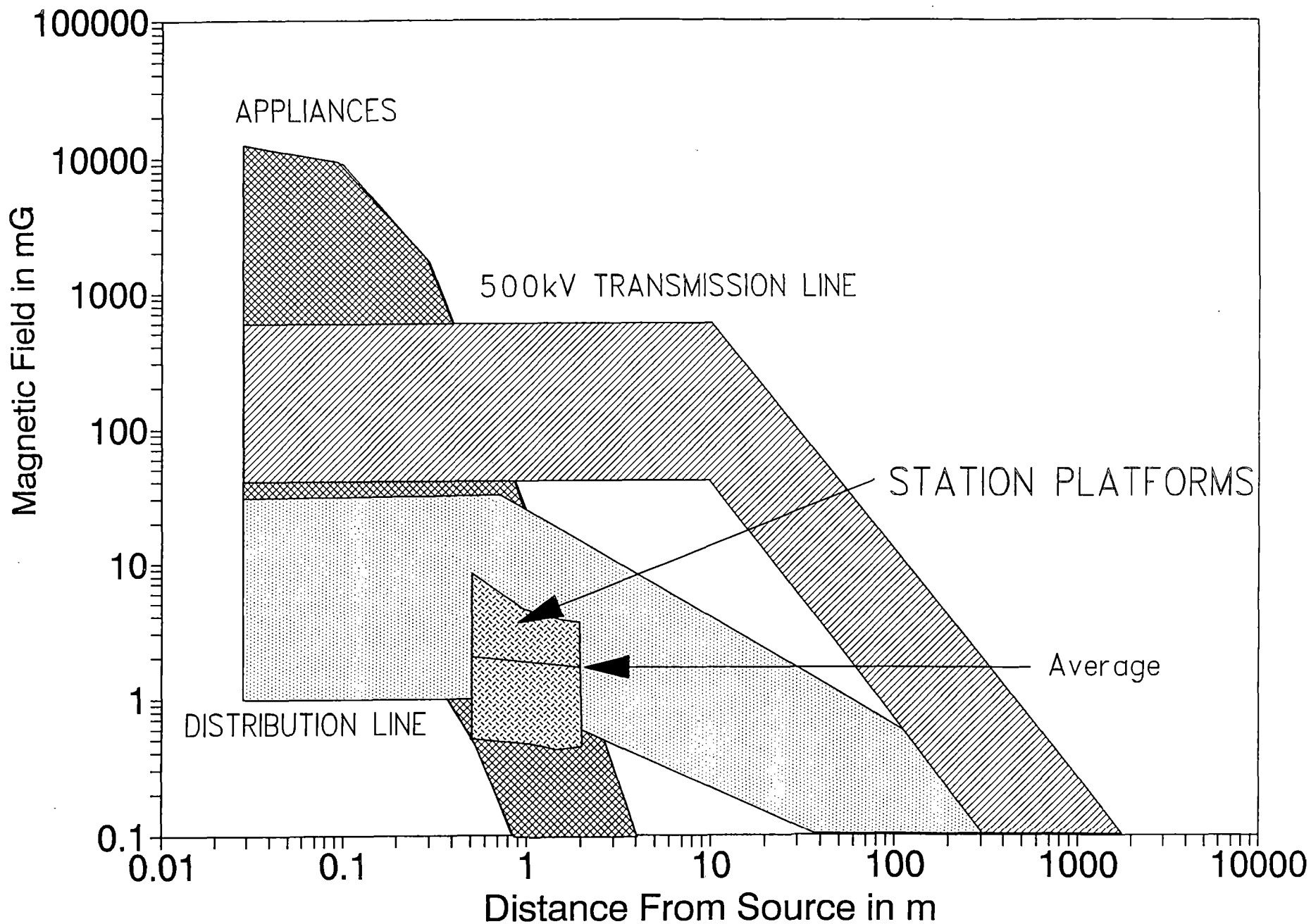

Figure 9-8 The range of total time varying magnetic field levels on the platforms, at various distances from the track, compared to typical levels of power frequency magnetic fields produced by common sources.

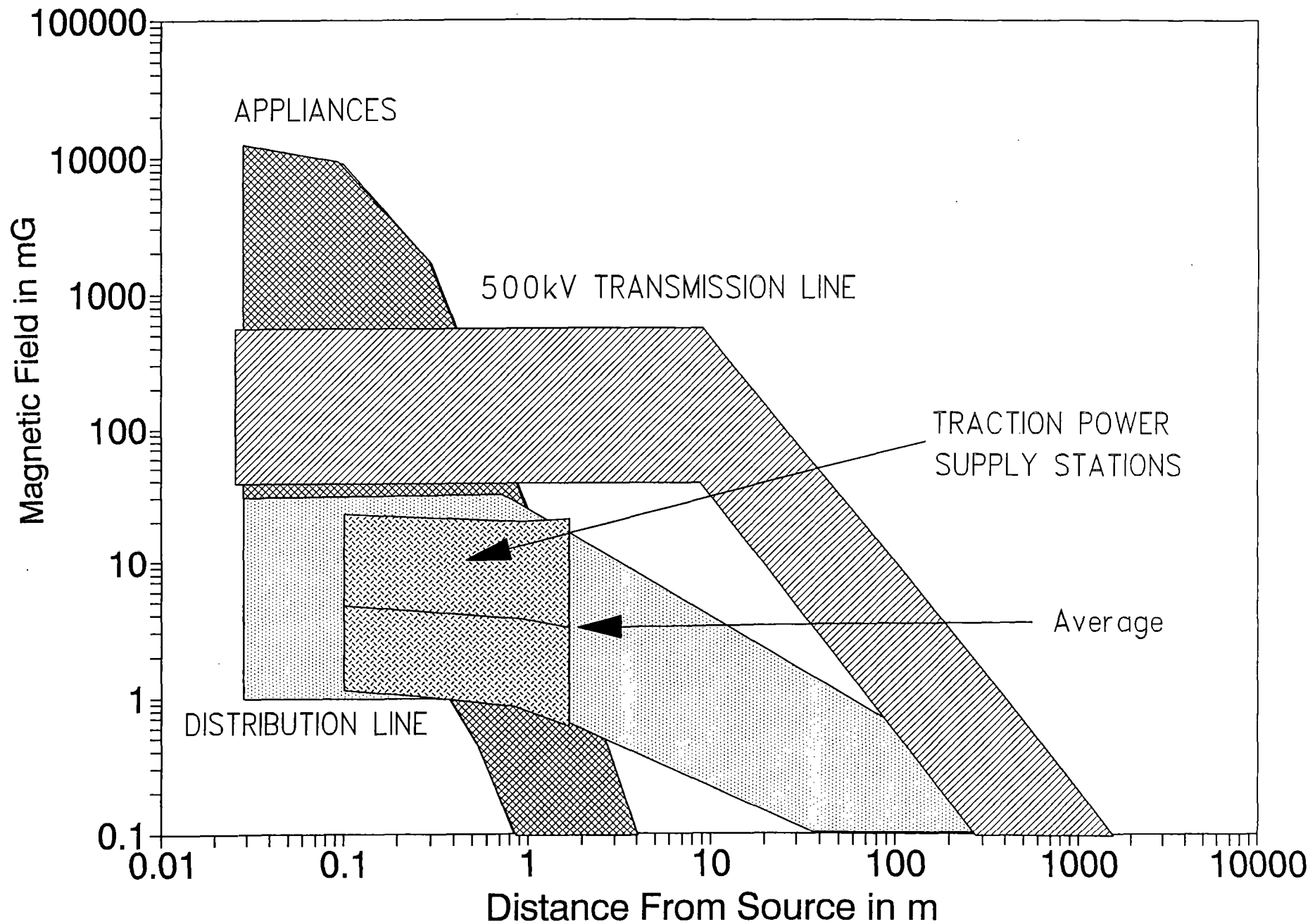

Figure 9-9 The range of total time varying magnetic field levels outside traction power supply stations, at various distances from the fence or wall, compared to typical levels of power frequency magnetic fields produced by common sources.

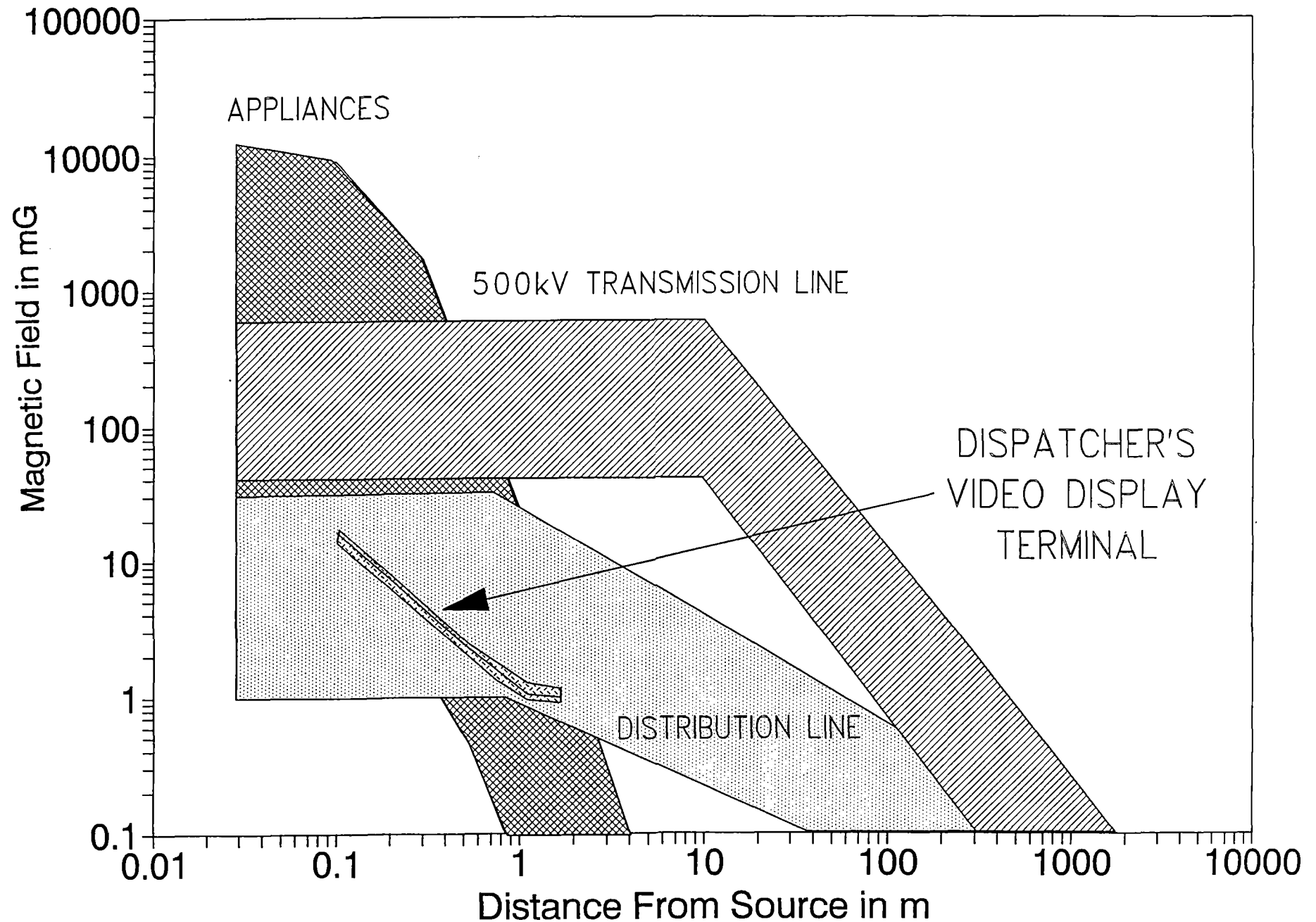

Figure 9-10 The range of total time varying magnetic field levels in front of a dispatcher's video display terminal compared to typical levels of power frequency magnetic fields produced by common sources.

established by a domestic professional trade organization. Furthermore, there are two state level standards limiting ELF magnetic fields and several others limiting ELF electric fields. These state standards presently apply only to electric power lines and substations. This subsection of the report will compare the magnetic field levels onboard the Metrorail cars or near related facilities to the field levels permitted under the above-mentioned standards. Figure 9-11 summarizes the overall comparison of the Metrorail magnetic fields to the existing standards. The comparison is made with the measured values at the center of the 3000 series car, that happened to be the highest values measured in all frequency bands. Field levels 60 cm above the floor were chosen for purposes of this comparison as that height is the approximate body center of a person in a seating position.

9.4.1 World Health Organization

The World Health Organization's *Environmental Health Criteria 35: Extremely Low Frequency (ELF) Fields*¹⁰ addresses both electric and magnetic fields but focuses more heavily on electric fields. Although it concludes that "adverse human health effects from exposure to ELF electric field levels normally encountered in the environment or the workplace have not been established" and sets no numerical limits for general or occupational exposure, it recommends limiting long-term exposures to 50/60 Hz electric fields to levels between 1 and 10 kV/m as "levels as low as can be reasonably achieved." The highest electric field levels encountered in these measurements were found outside the traction power supply station and they were 7 V/m, well below the lower end of this recommended limit.

The World Health Organization's *Environmental Health Criteria 69*¹¹ addresses ELF magnetic fields. The document concludes that available scientific knowledge does not permit establishment of a definitive limit for static or time varying magnetic fields. The document indicates that adverse human health effects are unlikely at static field levels less than 2 T (20,000 gauss) or with time varying magnetic fields which induce current densities of less than 10 mA/m² within tissue or extracellular fluids. Based on available scaling data for magnetically induced currents in the human body, the 10 mA/m² threshold is reached at 60 Hz field levels of approximately 10 gauss. The corresponding level at another ELF frequency would be adjusted from the 10 G value by the reciprocal of the ratio of the frequencies. Those values have been calculated for a number of frequencies and are plotted on Figure 9-11 as the World Health Organization criterion. The maximum time varying magnetic fields in various frequency bands measured 60 cm above the floor in the center of the 3000 series cars are plotted on Figure 9-11 and shown to be at least an order of magnitude below the World Health Organization criterion in

COMPARISON TO STANDARDS

Center of 3000 Series Car
At 60 cm Above The Floor

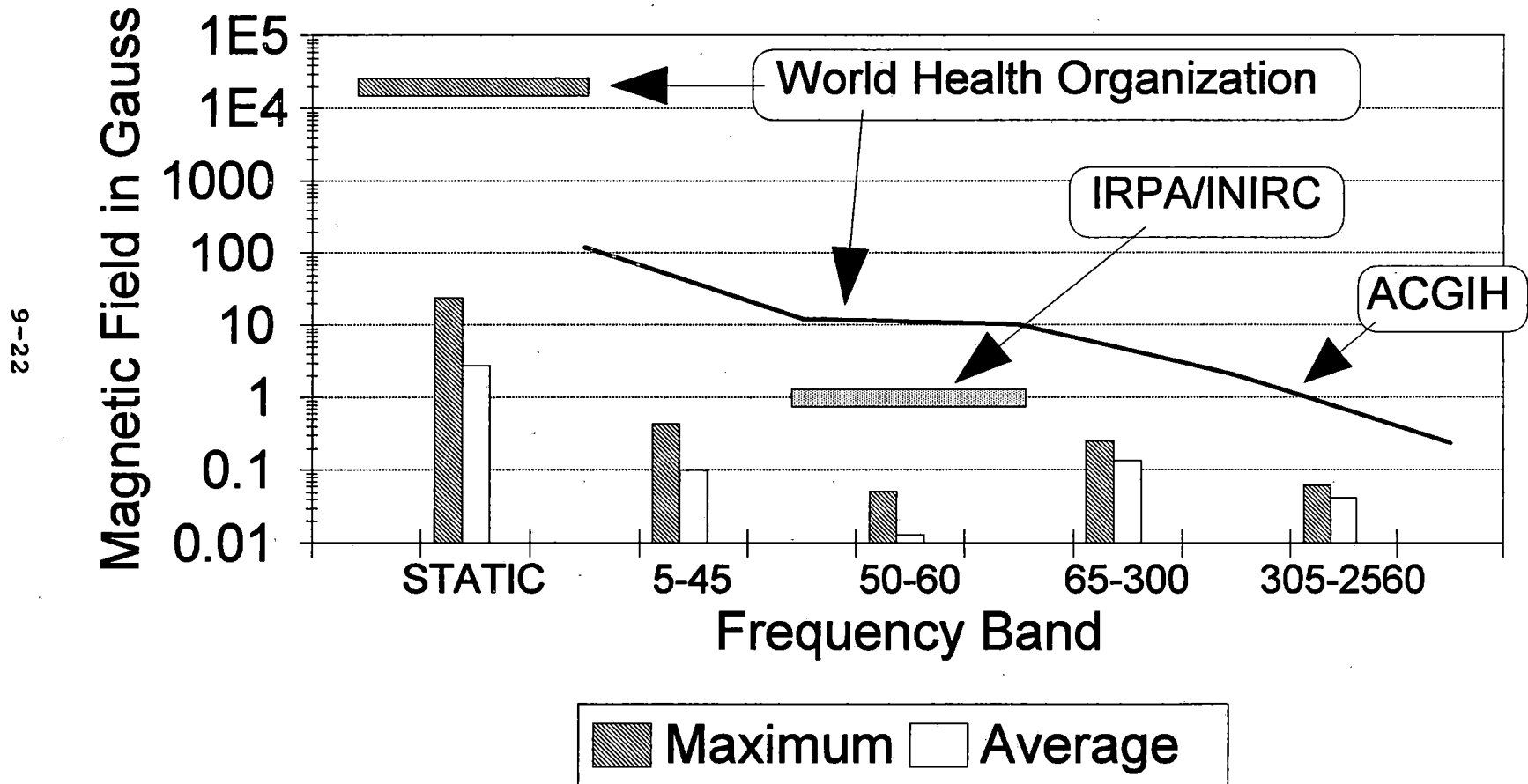

Figure 9-11

Comparison of maximum and average magnetic field levels measured 60 cm above the floor in the center of a Metrorail 3000 series car to existing standards.

each frequency band. The field levels in other locations in the 3000 series cars or in other cars or on the station platforms were less than those at the center of the 3000 series car so they, too, are well below the criteria. Even greater margins of compliance are found for static magnetic fields where the criteria is 20,000,000 mG.

9.4.2 International Radiation Protection Association

The International Non-Ionizing Radiation Committee (INIRC) of the International Radiation Protection Association (IRPA) has developed an interim standard¹² limiting human exposure to power frequency (50/60 Hz) electric and magnetic fields. The established magnetic field limit for 24 hours per day to the general public is 1 gauss. Short-term exposures of up to a few hours per day are permitted to 10 gauss. Permitted occupational exposure levels are five times that permitted for the general public. The average time varying power frequency magnetic field level at the center of the 3000 series Metrorail cars is approximately 1.3% of the 1 gauss, 24 hour limit. The average of the total ELF magnetic field 10 cm above the floor at the center of the 3000 series cars is 18% of the IRPA recommended limit. Average magnetic field levels in other parts of the train are less. The engineer's compartment levels are of the same general magnitude as in the other part of the cars.

The numerical field limits in the IRPA standard apply explicitly to power frequency magnetic fields. However, the text of the standard clearly demonstrates that the standard is based on induced current concerns. Hence, acceptable field limits at frequencies other than 50 or 60 Hz would be related to the 50/60 Hz threshold by the ratio of the power frequency to the frequency of the magnetic field. The average level of 273 Hz field component 60 cm above the floor at the center of the 3000 series car would still be below the IRPA 24-hour criterion (61%) even if the criterion was adjusted for frequency based on equivalent induced current.

9.4.3 American Conference of Governmental Industrial Hygienists

The American Conference of Governmental Industrial Hygienists (ACGIH) has established a "threshold limit value" (TLV) for 60 Hz magnetic fields at 10 gauss¹³. The document recommends that routine occupational exposures should not exceed the 10 gauss at 60 Hz, but states that the value is to be used as a guideline, not as a strict determination of safe and unsafe levels. For example, values ten times less than the above TLVs are recommended for persons with implanted pacemakers. These TLV values are comparable to the guidelines recommended by the World Health Organization and the tenfold lower level

suggested for pacemaker wearers is comparable to the IRPA guideline. As discussed above and shown graphically on Figure 9-11, the measured magnetic fields on or near the Metrorail System meet those criteria. However, the maximum 273 Hz magnetic field measured 60 cm above the floor in the center of the 3000 series cars exceeds the ten-fold lower threshold recommended for pacemaker wearers by approximately 15%. The average field at that position is 39% below the threshold suggested for pacemaker wearers.

The TLV for electric fields at frequencies of 100 Hz or less is 25 kV/m¹³. The highest electric field levels found in or around the existing Metrorail electrified urban transit facilities were outside traction power supply stations and it measured 7 V/m, well within the TLV guidelines.

9.4.4 State Power Line Limits

The states of Florida¹⁴ and New York¹⁵ have adopted standards specifically limiting the intensity of the power frequency electric and magnetic fields at the boundaries of transmission lines' rights-of-way or substation property lines to values from 1.6 to 2.0 kV/m and 150 mG to 250 mG, depending on the type of transmission line. Both standards are established on a "status quo" basis rather than a health or safety basis. Although neither applies to transportation systems, they do provide some guidance as to the levels of magnetic fields which have been judged tolerable at the boundaries of linear facilities which are in that respect similar to the Metrorail corridor. The maximum electric field found 170 cm from the fence was less than 7 V/m and the time varying magnetic field was less than 7 mG; both well below the transmission line limits.

10.0 REFERENCES

1. Interim Report on Magnetic Field Testing of TR07 Maglev Vehicle and System Conducted August 1990, Electric Research and Management, Inc., May 1991, Revised August 1991.
2. Safety of High Speed Magnetic Levitation Transportation Systems, "Magnetic Field Testing of the TR07 Maglev Vehicle and System, Volume I - Analysis", U.S. Department of Transportation, Federal Railroad Administration, Washington, DC, DOT/FRA/ORD-92/09.I, DOT-VNTSC-FRA-92-6.1, Final Report April 1992.
3. Final Report on Magnetic and Electric Field Testing of the AMTRAK Northeast Corridor and New Jersey Transit North Jersey Coast Line Rail Systems - Volume I, Electric Research and Management, Inc., December 1992.
4. Final Report on Magnetic and Electric Field Testing of the French Train à Grande Vitesse (TGV) Rail Systems - Volume I, Electric Research and Management, Inc., December 1992.
5. Biological Effects on Power Frequency Electric and Magnetic Fields, Indira Nair, M. Granger Morgan, H. Keith Florig, Office of Technology Assessment, OTA-BP-E-53, May 1989.
6. Magnetic Fields and Cancer in People Residing Near Swedish High Voltage Power Lines, Institutet för Miljömedicin, Karolinska Institutet, Maria Feychting, Anders Ahlbom, IMM-rapport 6/92, Stockholm 1992.
7. IEEE Standard Dictionary of Electrical and Electronic Terms, ANSI/IEEE Std 100-1988 Fourth Edition, IEEE, New York, NY.
8. Measurement of Power System Magnetic Fields by Waveform Capture, EPRI TR-100061, Project RP2942-1, Final Report, February 1992.
9. The EMDEX Project: Technology Transfer and Occupational Measurements, Volume 2: Project Description and Results, EPRI EN-7048 Volume 2, Project 2966-1, Interim Report, November 1990.
10. World Health Organization, Environmental Health Criteria 35: Extreme Low Frequency (ELF) Fields, Geneva, World Health Organization, 1984.
11. World Health Organization, Environmental Health Criteria 69: Magnetic Fields, Geneva, World Health Organization, 1987.

12. International Radiation Protection Association, Interim Guidelines on Limits of Exposure to 50/60 Hz Electric and Magnetic Fields, Health Physics 58; 113-22, 1990.
13. 1990-1991 Threshold Limit Values for Chemical Substances and Physical Agents and Biological Exposure Indices, American Conference of Governmental Industrial Hygienists, Third Printing.
14. Electric and Magnetic Fields, Chapter 17-274, Florida Administrative Code.
15. Statement of Interim Policy on Magnetic Fields of Major Electric Transmission Facilities, State of New York Public Service Commission, September 11, 1990.

PROPERTY OF FRA
RESEARCH & DEVELOPMENT
LIBRARY

Final Report on Magnetic and Electric Field Testing
of the Washington Metropolitan Area Transit
Authority Metrorail System, Volume I-Analysis,
Electric Research and Management, Inc, 1993-11-
Advanced Systems

SMEAD COMPANY