

**ELECTRIC RESEARCH  
& MANAGEMENT, INC.**

**FINAL REPORT ON  
MAGNETIC AND ELECTRIC FIELD TESTING  
OF THE FRENCH TRAIN A GRANDE  
VITESSE-ATLANTIQUE (TGV-A) RAIL SYSTEMS**

**VOLUME II - APPENDICES**

**prepared for:**

**U.S. DEPARTMENT OF TRANSPORTATION  
FEDERAL RAILROAD ADMINISTRATION**

**CONTRACT NO. DTFR53-91-C-00047**

**prepared by:**

**ELECTRIC RESEARCH AND MANAGEMENT, INC.  
P.O. BOX 165  
STATE COLLEGE, PA 16804**

**APRIL 1993**

**SYSTÈME INTERNATIONAL (SI) UNIT DEFINITIONS AND  
CONVERSIONS USED IN THIS REPORT**

**DISTANCE (ENGLISH-TO-SI CONVERSION):**

1 inch (in)	= 2.54 centimeters (cm)	= 0.025 meters (m)
1 foot (ft)	= 30.5 centimeters (cm)	= 0.305 meters (m)
1 yard (yd)	= 91.4 centimeters (cm)	= 0.914 meters (m)
1 mile (mi)	= 1.61 kilometers (km)	= 1,610 meters (m)

**ELECTRICAL QUANTITIES:**

**Electric Fields**

1 Volt/meter (V/m)	= 0.01 Volts/centimeter (V/cm)
1 kiloVolt/meter (kV/m)	= 1000 Volts/meter (V/m)
1 kiloVolt/meter (kV/m)	= 10 Volts/centimeter (V/cm)

**Magnetic Flux Densities (English-to-SI Conversion)**

10,000 Gauss (G)	= 1 Tesla (T)
10 milliGauss (mG)	= 1 microTesla ( $\mu$ T)
1 milliGauss (mG)	= .1 microTesla ( $\mu$ T)
0.01 milliGauss (mG)	= 1 nanoTesla (nT)

**Electromagnetic Frequency Bands**

1 cycle per second	= 1 Hertz (Hz)
1,000 cycles per second	= 1 kiloHertz (kHz)
Ultra Low Frequency (ULF) Band	= 0 Hz to 3 Hz
Extreme Low Frequency (ELF) Band	= 3 Hz to 3 kHz
Very Low Frequency (VLF) Band	= 3 kHz to 30 kHz
Low Frequency (LF) Band	= 30 kHz to 300 kHz

## TABLE OF CONTENTS

### VOLUME II - APPENDICES

<u>APPENDIX</u>	<u>TITLE</u>
A	Description of Appended Data
B	Dataset TGV001 - First Class Salon - Front of Coach R1B
C	Dataset TGV002 - First Class Salon - Front of Coach R1B
D	Dataset TGV003 - Axial Profile - First Class Salon at Front of Coach R1B
E	Dataset TGV004 - Transverse Profile - First Class Salon at Front of Coach R1B
F	Dataset TGV005 - Test Train Locomotive Against Engineer's Chair
G	Dataset TGV006 - Test Train Locomotive Against Engineer's Chair
H	Dataset TGV007 - Transverse Profile From Side Wall - Test Train Locomotive
I	Dataset TGV008 - Axial Profile From Rear Wall - Test Train Locomotive
J	Dataset TGV009 - Test Train Locomotive Against Engineer's Chair
K	Dataset TGV010 - TGV Control Center Montparnasse Station
L	Dataset TGV011 - Horizontal Profile From Console Monitor TGV Control Center Montparnasse Station
M	Dataset TGV012 - Center of First Class Coach R2B
N	Dataset TGV013 - Transverse Profile From Side Wall - First Class Coach R2B
O	Dataset TGV014 - Axial Profile From Center - First Class Coach R2B
P	Dataset TGV015 - Vendome Station Relay Room Near AC Supply Cabinet

TABLE OF CONTENTS (CONT'D)

VOLUME II - APPENDICES

<u>APPENDIX</u>	<u>TITLE</u>
Q	Dataset TGV016 - Vendome Station Relay Room Between Two Rows of Relay Shelves
R	Dataset TGV017 - Vendome Station Platform as Train From Paris Passed
S	Dataset TGV018 - Vendome Station Platform as Train From Paris Passed
T	Dataset TGV019 - Vendome Station Platform as Train To Paris Passed
U	Dataset TGV020 - Center of Second Class Coach R5B
V	Dataset TGV021 - Center of Second Class Coach R5B
W	Dataset TGV022 - Transverse Profile From Side Wall - Second Class Coach R5B
X	Dataset TGV023 - Axial Profile From Center - Second Class Coach R5B
Y	Dataset TGV024 - Center of Second Class Coach R5B
Z	Dataset TGV025 - Revenue Train Locomotive Against Engineer's Chair
AA	Dataset TGV026 - Revenue Train Locomotive Against Engineer's Chair
AB	Dataset TGV027 - At Chaillot Autotransformer
AC	Dataset TGV028 - At Chaillot Autotransformer
AD	Dataset TGV029 - Overpass
AE	Dataset TGV030 - Underpass
AF	Dataset TGV031 - Wayside Near 104 km Marker
AG	Dataset TGV032 - Behind Gault St. Denis Substation
AH	Dataset TGV033 - Behind Gault St. Denis Substation
AI	Dataset TGV034 - Inside Control House at Gault St. Denis Substation

## APPENDIX A

### DESCRIPTION OF APPENDED DATA

The following 34 appendices contain a detailed reporting of the magnetic field characteristics measured onboard the electrified railroad and near associated facilities. The data have been consolidated and presented as efficiently as possible without resorting to summary measures which obscure the temporal or frequency characteristics of the magnetic fields. The analysis of summary data obtained by collapsing the frequency spectra into a small number of relatively broad bands or by collapsing the time distributions into statistical parameters is found in the body of the report.

One appendix is provided for each of the 34 repetitive waveform datasets collected during the September 8 and 9, 1992 measurement program along the TGV Atlantique Paris - Tours Line. Table A-1 provides a list of the datasets and the relevant parameters, and the appendix where each dataset may be found. Appendices may contain the following material:

- Table of measurement parameters
- Vehicle speed profile
- Vehicle load current profile
- Field by frequency and time plots for each field sensor
- Field by distance and time plot for six frequency bands
- Summary statistics

Each of these items is described below.

#### Table of Measurement Parameters

Each appendix begins with a table of measurement parameters. It identifies the dataset by number and title and gives measurement setup code which refers to the sensor staff and reference probe locations on the appropriate sketch of the measurement setup. (Copies of the setup sketches are included in this appendix as Drawings A-1 through A-10.) The vehicle status entry indicates whether the trains were operating during the test and includes general comments on the mode of operation.

The next group of data on the table of measurement parameters identifies the time during which repetitive waveform measurements were made. Start and stop time are merely clock times for the first and last waveform samples, respectively. During that time period, the indicated number of waveform samples were taken. The programmed sample interval and actual sample interval represent the requested and actual time between successive waveform samples. These should agree, except during those tests in which the test engineers wanted the waveform capture system to sample as

frequently as possible. In this mode, samples are sometimes delayed if the system is automatically adjusting its programmable amplifiers in response to a sudden change in field intensity.

The table of measurement parameters also contains various parameters from the waveform sampling and subsequent Fourier transformation of the waveform data that affect the interpretation of the magnetic field frequency spectra. The tabulated maximum frequency and minimum frequency are center frequencies of the upper and lower components of the Fourier transform. The spectral bandwidth is the interval between frequency components in the Fourier transform and is effectively the smallest increment in frequency that can be resolved in the frequency spectrum. The spectral bandwidth parameter is also important to the reader because the intensity of broadband magnetic field components (as opposed to fields at unique discrete frequencies) is proportional to the square root of the bandwidth. Consequently, to compare the spectral data for broadband signals contained in these appendices to values reported by others, one must make the appropriate bandwidth adjustments to the data.

The final item on the table of measurement parameters is a listing of any missing or suspect data within that particular dataset.

#### Vehicle Speed Profile

During the magnetic field measurements in locomotive cabs, the test engineers were occasionally able to maintain a manual log of train speed readings from the vehicle's speedometer. Those data are plotted in the vehicle speed profile and are useful when interpreting the changes in magnetic field conditions which occur over the time of the measurements.

#### Field by Frequency and Time Plots for Each Sensor

The first set of data plots in each appendix is the field by frequency and time plots for each magnetic field sensor. These plots are described in more detail in Section 2 of this report. The top frame of each page shows the static magnetic field component and time varying components up to 64 Hz. The lower frame has the static field suppressed to show the time varying magnetic field components in more detail. Although all of the time varying magnetic measurements extended out to a maximum frequency of 2560 Hz, only that portion of the spectrum containing fields of significant amplitude were plotted. In some cases, supplemental plots showing extended portions of the frequency spectrum or "blow-ups" of portions of the time domain are included to show interesting field characteristics in more detail.

### **Field by Distance and Time Plots**

The next group of graphs in each appendix show the intensity of the field in each of six frequency bands as a function of distance from some reference point (such as floor of the vehicle, etc.) over the time of the measurements. These graphs were created for each set of measurements whether the spatial distribution was expected to help identify the source of the magnetic field or establish an attenuation rate which would be useful for predicting field intensities at other distances from the source.

The spatial sampling of the magnetic field level is by necessity limited to only the few points where magnetic field sensors were placed (see the sketch of sensor locations in each appendix). From this relatively sparse sample, the contours of the field by distance and time plots were generated by a computer program which attempts to fit a surface to the available data points. These plots are therefore very accurate at the sensor locations but represent a "best fit" approximation of the field levels between sensor locations. In those cases where the attenuation data are orderly and consistent, the contours are expected to be a good approximation of reality. However, in the cases where field values are erratic or inconsistent between probe locations, the validity of the contour is more uncertain at places other than the sample locations. In evaluating these curves, the reader should be cognizant of the actual measurement locations and place the most credibility in the data at those locations.

### **Summary Statistics**

Statistical summaries of individual datasets are also included in the appendix. Those summaries consist of tables of field strength and variability parameters.



TABLE A-1

INDEX OF REPETITIVE WAVEFORM DATA  
 FRENCH TGV  
 SEPTEMBER 8 - SEPTEMBER 9, 1992

DATA FILE NUMBER	APPENDIX CONTAINING DATA	DATE/ TIME	PROBE LOCATION			SAMPLE INTERVAL, SECONDS	NUMBER OF SAMPLES	LOCATION AND TYPE OF MEASUREMENT
			FIG.	STAFF	REF.			
		SEP 08						
TGV001	B	07:57- 08:17	3-2	1	4	10	101	TGV TEST TRAIN, DOUBLE TRAIN SET, IN 1ST COACH, (R1B, FIGURE 3-1). FOUR SENSOR STAFF AT FRONT OF COACH IN 1ST CLASS SALON. STAFF IN VERTICAL POSITION. FLOOR OF COACH AS REFERENCE.
TGV002	C	08:18- 08:22	3-2	1	4	30	09	SAME
TGV003	D	08:23- 08:27	3-2	2	4	30	10	SAME EXCEPT STAFF IS IN A HORIZONTAL POSITION ALONG THE AXIS OF THE TRAIN 1 M (3.3 FT) ABOVE THE FLOOR. DOOR ABOVE MIDDLE SEAT IS REFERENCE.
TGV004	E	08:28- 08:33	3-2	3	4	30	10	SAME EXCEPT STAFF IS IN A HORIZONTAL POSITION TRANSVERSE TO THE AXIS OF THE TRAIN 1 M (3.3 FT) ABOVE THE FLOOR. WINDOW ABOVE SIDE SEAT IS REFERENCE.

TABLE A-1 (CONT.)

DATA FILE NUMBER	APPENDIX CONTAINING DATA	DATE/ TIME	PROBE LOCATION			SAMPLE INTERVAL, SECONDS	NUMBER OF SAMPLES	LOCATION AND TYPE OF MEASUREMENT
			FIG.	STAFF	REF.			
TGV005	F	09:15- 09:29	4-1	5	8	10	75	TGV TEST TRAIN, DOUBLE TRAIN SET, IN PULL LOCOMOTIVE TGV24081 (TU1B, FIGURE 3-1). FOUR SENSOR STAFF AT DRIVERS RIGHT SHOULDER IN THE LOCOMOTIVE CAB. STAFF IN VERTICAL POSITION. FLOOR OF CAB AS REFERENCE.
TGV006	G	09:30- 09:42	4-1	5	8	30	25	SAME
TGV007	H	09:43- 09:48	4-1	6	8	30	10	SAME EXCEPT STAFF IS IN A HORIZONTAL POSITION TRANSVERSE TO THE AXIS OF THE TRAIN 1 M (3.3 FT) ABOVE THE FLOOR. SIDE WALL OF CAB IS REFERENCE.
TGV008	I	09:49- 09:53	4-1	7	8	30	10	SAME EXCEPT STAFF IS IN A HORIZONTAL POSITION ALONG THE AXIS OF THE TRAIN 1.3 M (4.3 FT) ABOVE THE FLOOR. BACK WALL OF CAB IS THE REFERENCE.
TGV009	J	09:56- 10:14	4-1	5	8	30	38	STAFF IN SAME POSITION AS FOR DATASET TGV005
TGV010	K	10:50- 10:51	8-1	10	12	10	10	IN THE TGV CONTROL CENTER ON 6TH FLOOR IN FRONT OF COMPUTER MONITORS. USING 4 SENSOR STAFF IN THE VERTICAL POSITION. FLOOR OF CONTROL CENTER IS THE REFERENCE.

TABLE A-1 (CONT.)

DATA FILE NUMBER	APPENDIX CONTAINING DATA	DATE/TIME	PROBE LOCATION			SAMPLE INTERVAL, SECONDS	NUMBER OF SAMPLES	LOCATION AND TYPE OF MEASUREMENT
			FIG.	STAFF	REF.			
TGV011	L	10:52-10:54	8-1	11	12	10	10	SAME EXCEPT STAFF IS IN THE HORIZONTAL DIRECTION .9 M (3 FT) ABOVE THE FLOOR. CENTER OF A MONITOR SCREEN IS THE REFERENCE.
TGV012	M	14:03-14:20	3-3	13	16	10	95	TGV TEST TRAIN, DOUBLE TRAIN SET, IN 2ND COACH (R2B, FIGURE 3-1). FOUR SENSOR STAFF IN CENTER OF A 1ST CLASS CLUB CAR. STAFF IN VERTICAL DIRECTION. FLOOR OF COACH AS REFERENCE.
TGV013	N	14:21-14:26	3-3	14	16	30	10	SAME EXCEPT STAFF IS IN A HORIZONTAL POSITION TRANSVERSE TO THE AXIS OF THE TRAIN 1 M (3.3 FT) ABOVE THE FLOOR. SIDE WALL ABOVE SEATS 42 & 43 IS THE REFERENCE.
TGV014	O	14:28-14:32	3-3	15	16	30	10	SAME EXCEPT STAFF IS IN A HORIZONTAL POSITION ALONG THE AXIS OF THE TRAIN 1 M (3.3 FT) ABOVE THE FLOOR. MIDLINE BETWEEN SEATS 41 & 42 IS THE REFERENCE.
TGV015	P	15:09-15:11	8-2	17	-	10	12	IN VENDOME RELAY ROOM. FOUR SENSOR STAFF NEAR AC POWER CABINET. STAFF IN VERTICAL POSITION. FLOOR OF RELAY ROOM IS REFERENCE.

TABLE A-1 (CONT.)

DATA FILE NUMBER	APPENDIX CONTAINING DATA	DATE/ TIME	PROBE LOCATION			SAMPLE INTERVAL, SECONDS	NUMBER OF SAMPLES	LOCATION AND TYPE OF MEASUREMENT
			FIG.	STAFF	REF.			
TGV016	Q	15:15- 15:17	8-2	18	-	10	12	IN VENDOME RELAY ROOM. FOUR SENSOR STAFF BETWEEN TWO ROWS, OF RELAYS. STAFF IN VERTICAL POSITION. FLOOR OF RELAY ROOM IS REFERENCE.
TGV017	R	16:03- 16:05	6-1	19	20	5	13	ON TGV PLATFORM AT VENDOME. HIGH SPEED TRAIN TO TOURS ON FAR TRACK. SINGLE TRAIN SET. FOUR SENSOR STAFF. STAFF IN VERTICAL POSITION. TO PARIS PLATFORM FLOOR AS REFERENCE.
TGV018	S	16:34- 16:45	6-1	19	20	5	73	SAME EXCEPT A DIFFERENT TRAIN PASSED HEADING TO TOURS.
TGV019	T	16:50- 16:54	6-1	19	20	5	25	SAME EXCEPT HIGH SPEED TRAIN TO PARIS ON THE NEAR TRACK. DOUBLE TRAIN SET.
TGV020	U	17:14- 17:16	3-4	21	24	5	22	TGV TEST TRAIN, DOUBLE TRAIN SET, IN 5TH COACH (R5B, FIGURE 3-1). FOUR SENSOR STAFF IN CENTER OF 2ND CLASS CAR. STAFF IN VERTICAL POSITION. FLOOR OF COACH NEAR CORNER OF SEAT 47 IS THE REFERENCE.
TGV021	V	17:17- 17:27	3-4	21	24	5	63	SAME

TABLE A-1 (CONT.)

DATA FILE NUMBER	APPENDIX CONTAINING DATA	DATE/TIME	PROBE LOCATION			SAMPLE INTERVAL, SECONDS	NUMBER OF SAMPLES	LOCATION AND TYPE OF MEASUREMENT
			FIG.	STAFF	REF.			
TGV022	W	17:28-17:32	3-4	22	24	30	10	SAME EXCEPT STAFF IS IN A HORIZONTAL POSITION TRANSVERSE TO THE AXIS OF THE TRAIN 1 M (3.3 FT) ABOVE THE FLOOR. SIDE WINDOW ACROSS FROM SEATS 41 & 42 IS THE REFERENCE.
TGV023	X	17:33-17:38	3-4	23	24	30	10	SAME EXCEPT STAFF IS IN A HORIZONTAL POSITION ALONG THE AXIS OF THE TRAIN 1 M (3.3 FT) ABOVE THE FLOOR. CORNER OF SEAT 46 IS THE REFERENCE.
TGV024	Y	17:38-17:54	3-4	21	24	30	32	STAFF IN SAME POSITION AS FOR DATASET TGV020
		SEP 09						
TGV025	Z	07:45-08:01	4-2	25	26	10	88	TGV REVENUE TRAIN, SINGLE TRAIN SET, IN PULL LOCOMOTIVE TGV24006 (TU2, FIGURE 3-1). FOUR SENSOR STAFF AT DRIVER'S RIGHT SHOULDER IN THE LOCOMOTIVE CAB. STAFF IN VERTICAL DIRECTION. FLOOR OF CAB IS STAFF REFERENCE.
TGV026	AA	08:01-08:21	4-2	25	26	30	40	SAME

TABLE A-1 (CONT.)

DATA FILE NUMBER	APPENDIX CONTAINING DATA	DATE/ TIME	PROBE LOCATION			SAMPLE INTERVAL, SECONDS	NUMBER OF SAMPLES	LOCATION AND TYPE OF MEASUREMENT
			FIG.	STAFF	REF.			
TGV027	AB	10:16- 10:18	7-2	27	28	10	12	TGV AUTOTRANSFORMER AT CHAILLOT. MEASUREMENTS OUTSIDE BACK FENCE OF AUTOTRANSFORMER ALONG TGV LINE AT CHAILLOT NEAR THE 121 KM MARKER. STAFF IN VERTICAL POSITION. GROUND IS STAFF REFERENCE.
TGV028	AC	10:26- 10:34	7-2	27	28	10	36	SAME
TGV029	AD	10:58- 11:03	5-1	29	30	5	33	OVERPASS NEAR THE 120 KM MARKER CLOSE TO CHAILLOT. MEASUREMENTS OVER THE CATENARY 1 M (3.3 FT) FROM THE STEEL GUARD RAIL. MEASUREMENTS TAKEN AS HIGH SPEED (DOUBLE TRAIN SET) TRAIN TO PARIS PASSED UNDER THE OVERPASS. STAFF IN VERTICAL POSITION. GROUND IS STAFF REFERENCE.
TGV030	AE	13:24- 13:29	5-2	31	32	10	23	UNDERPASS NEAR THE 105 KM MARKER CLOSE TO BONNEVAL. MEASUREMENTS TAKEN AS HIGH SPEED TRAIN TO PARIS PASSED OVER THE UNDERPASS. STAFF IN VERTICAL POSITION. GROUND IS STAFF REFERENCE.

TABLE A-1 (CONT.)

DATA FILE NUMBER	APPENDIX CONTAINING DATA	DATE/ TIME	PROBE LOCATION			SAMPLE INTERVAL, SECONDS	NUMBER OF SAMPLES	LOCATION AND TYPE OF MEASUREMENT
			FIG.	STAFF	REF.			
TGV031	AF	14:15- 14:32	5-3	33	34	10	83	OPEN SPACE NEAR TRACK AT THE 104 KM MARKER. MEASUREMENT STAFF 7.5 M (24.6 FT) FROM THE NEAR TRACK (TO PARIS). MEASUREMENTS TAKEN FOR DOUBLE TRAIN SET TO TOURS, SINGLE TRAIN SET TO TOURS, AND SINGLE TRAIN SET TO PARIS. STAFF IN THE VERTICAL POSITION. GROUND IS STAFF REFERENCE.
TGV032	AG	15:18- 15:22	7-1	35	36	10	25	GAULT ST. DENIS SUBSTATION AT THE 94.75 KM MARKER. MEASUREMENTS TAKEN 2 M (6.6 FT) OUTSIDE OF FENCE AT THE BACK OF THE SUBSTATION. DURING MEASUREMENT SEQUENCE SINGLE TRAIN SET TO PARIS PASSED. STAFF IN THE VERTICAL POSITION. GROUND IS STAFF REFERENCE.
TGV033	AH	15:25- 15:28	7-1	35	36	10	19	SAME
TGV034	AI	15:43- 15:56	7-1	37	38	10	68	SAME EXCEPT MEASUREMENT WAS TAKEN IN SIDE OF THE SUBSTATION CONTROL HOUSE. MEASUREMENT TAKEN WHILE SINGLE TRAIN SET TO TOURS AND A SINGLE TRAIN SET TO PARIS PASSED BY. STAFF IN THE VERTICAL DIRECTION. CONTROL HOUSE FLOOR IS STAFF REFERENCE.

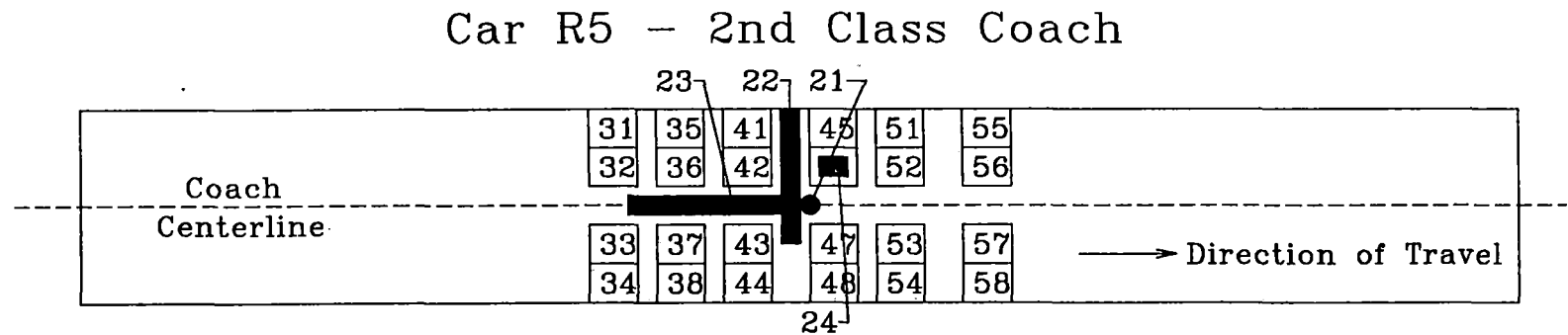
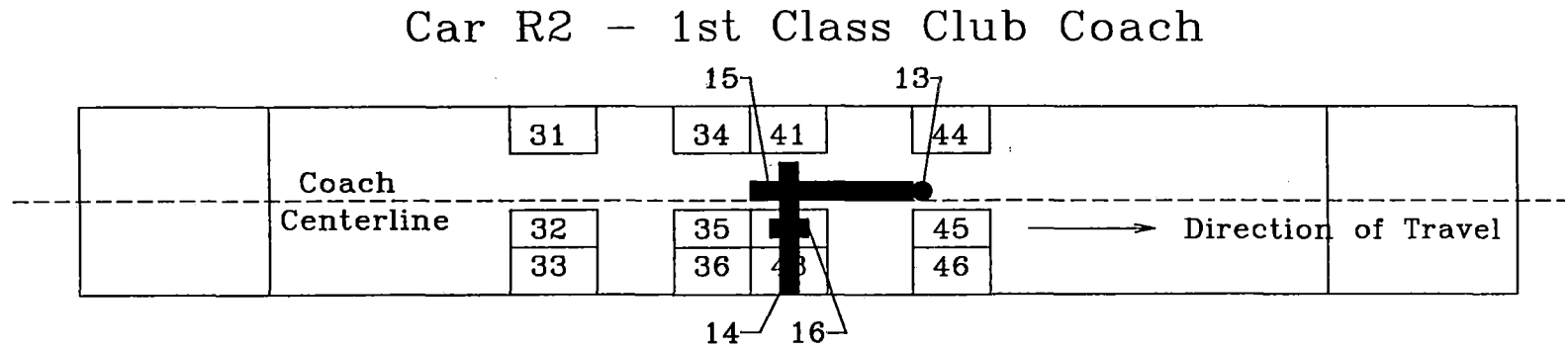
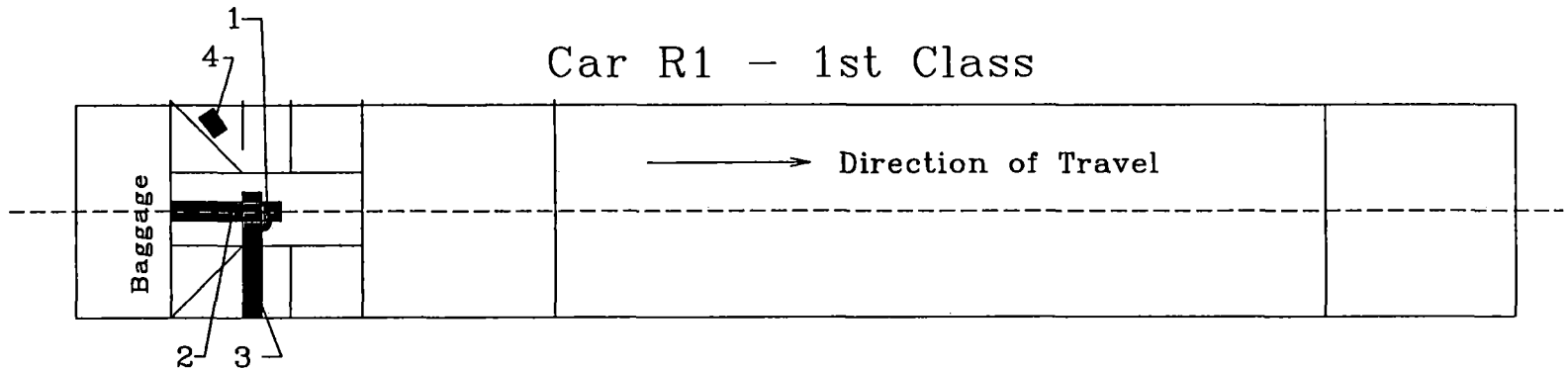

DRAWING A-1



# First Locomotive of Test Train

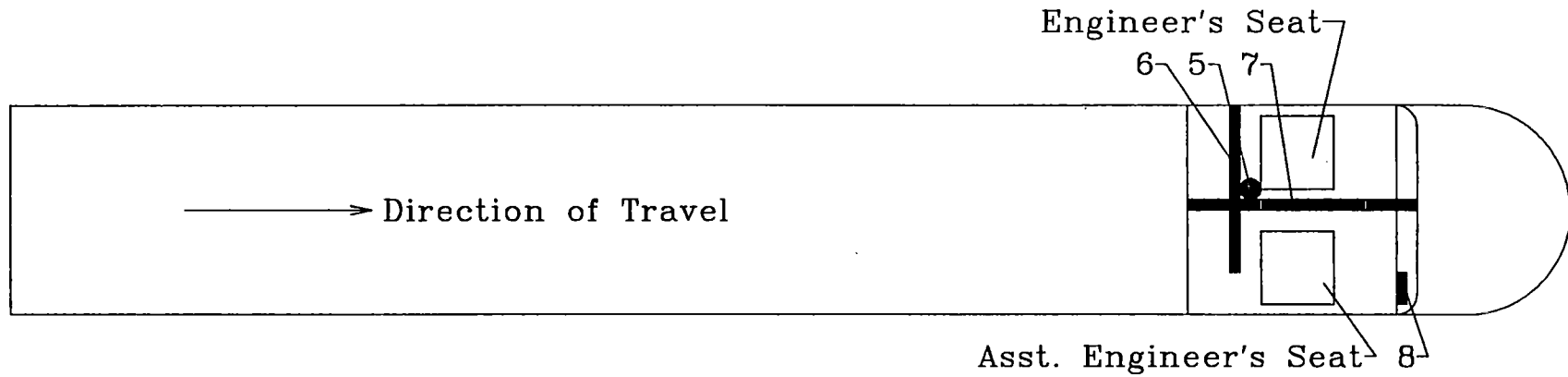

# First Locomotive of Revenue Train

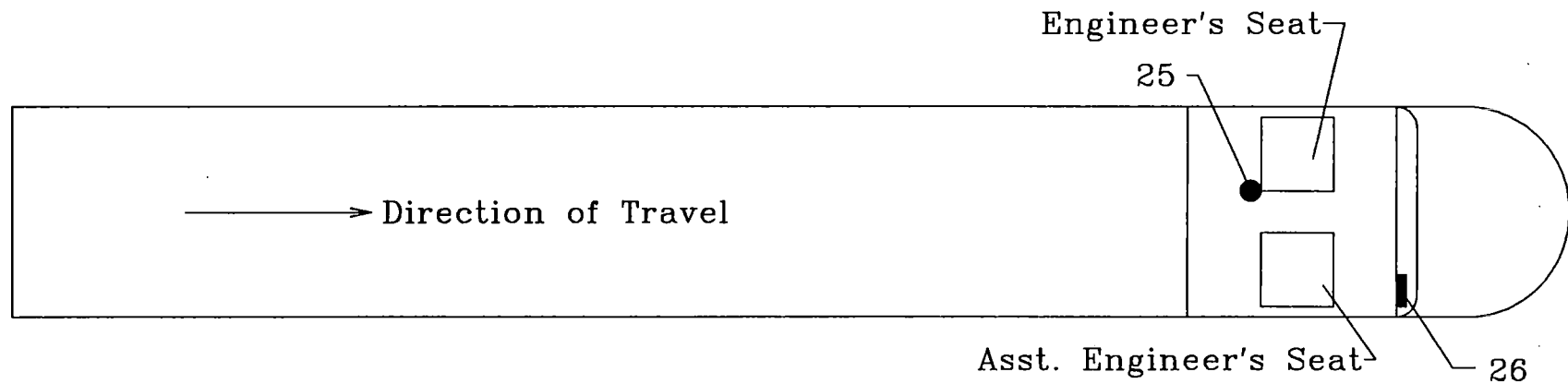

DRAWING A-2

TGV Control Center  
in Paris (Montparnasse Station)

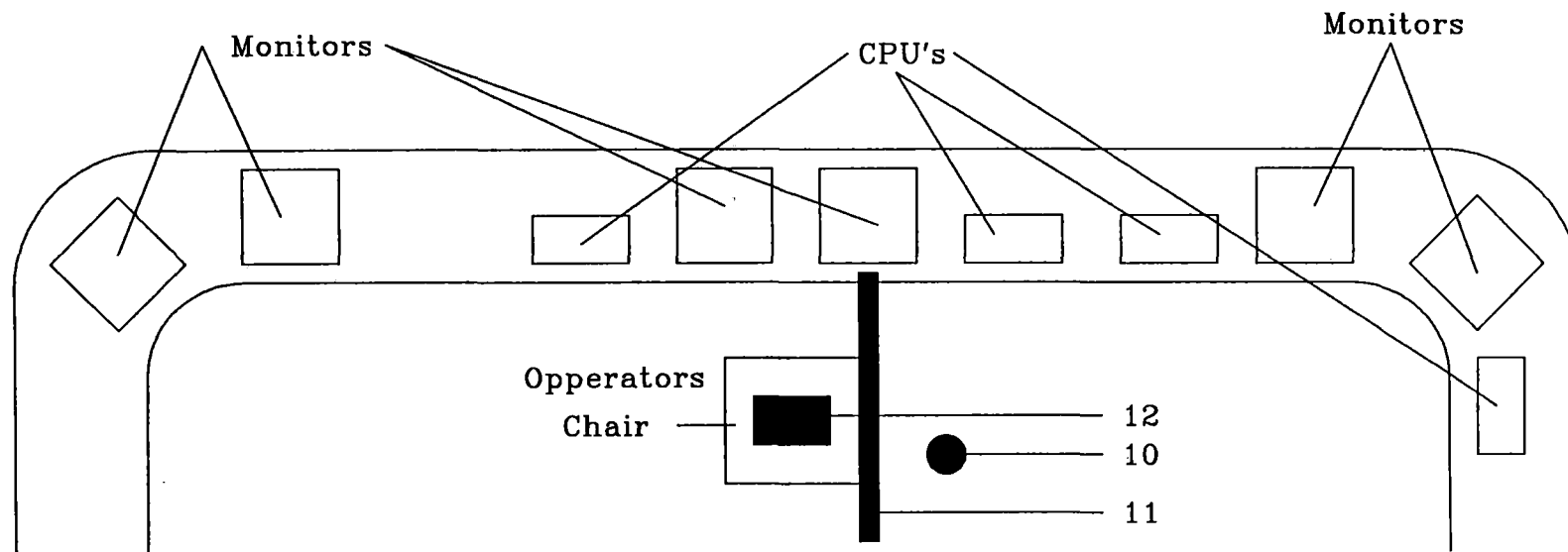

DRAWING A-3

# Relay Room Vendôme Station

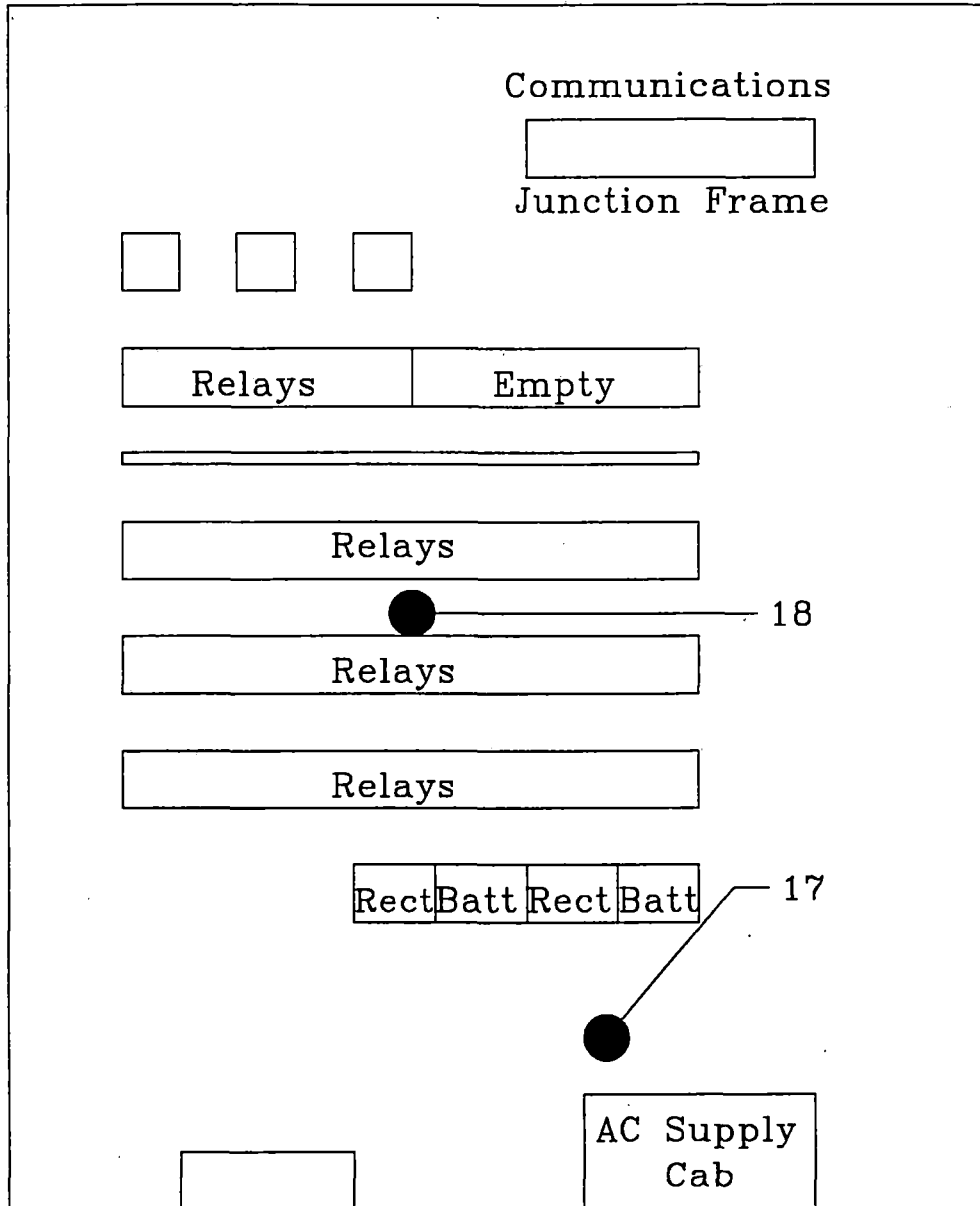

DRAWING A-4

# Vendôme Station

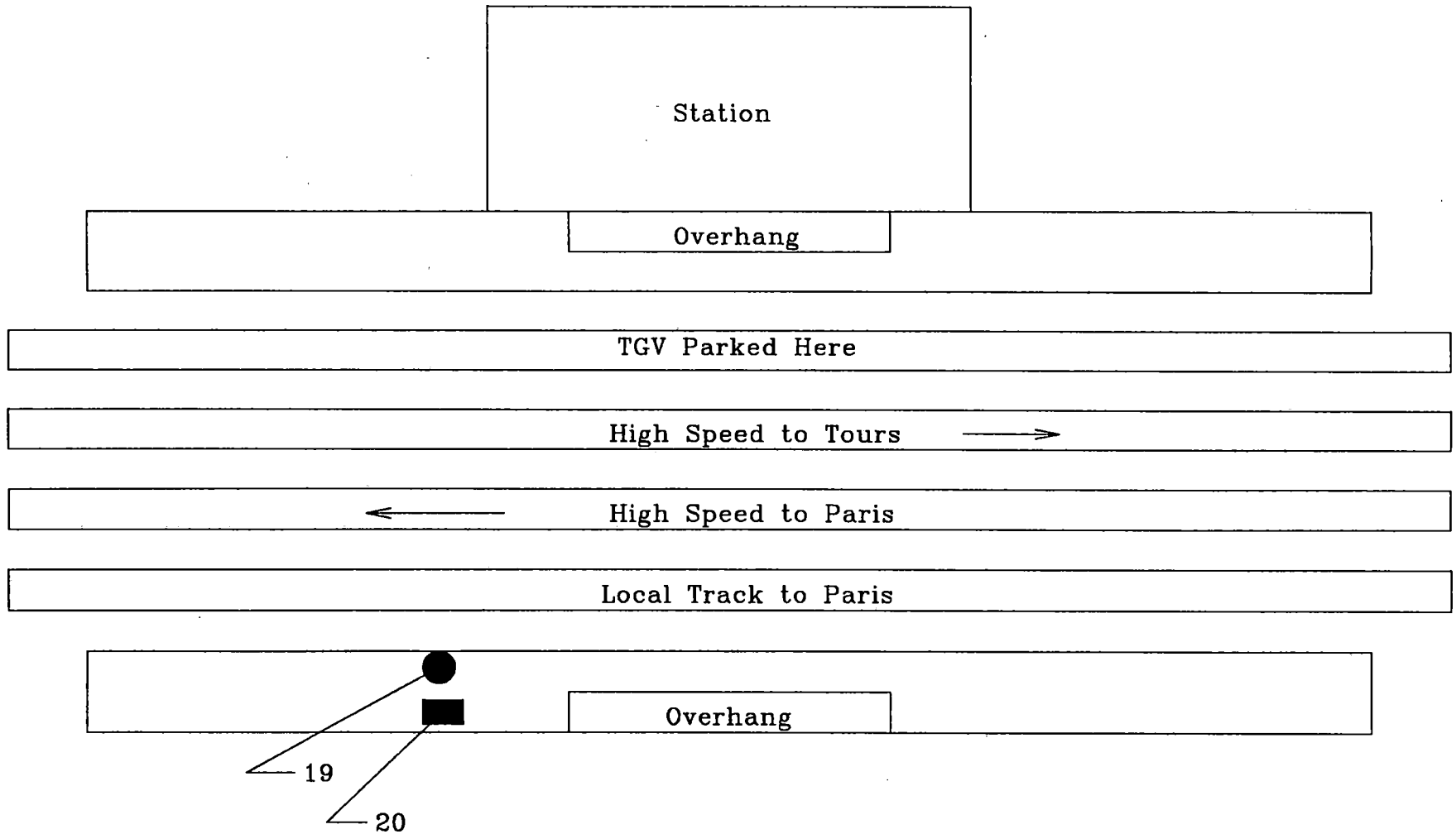

DRAWING A-5

# Auto-Transformer Station Chaillot at Marker 120.875km

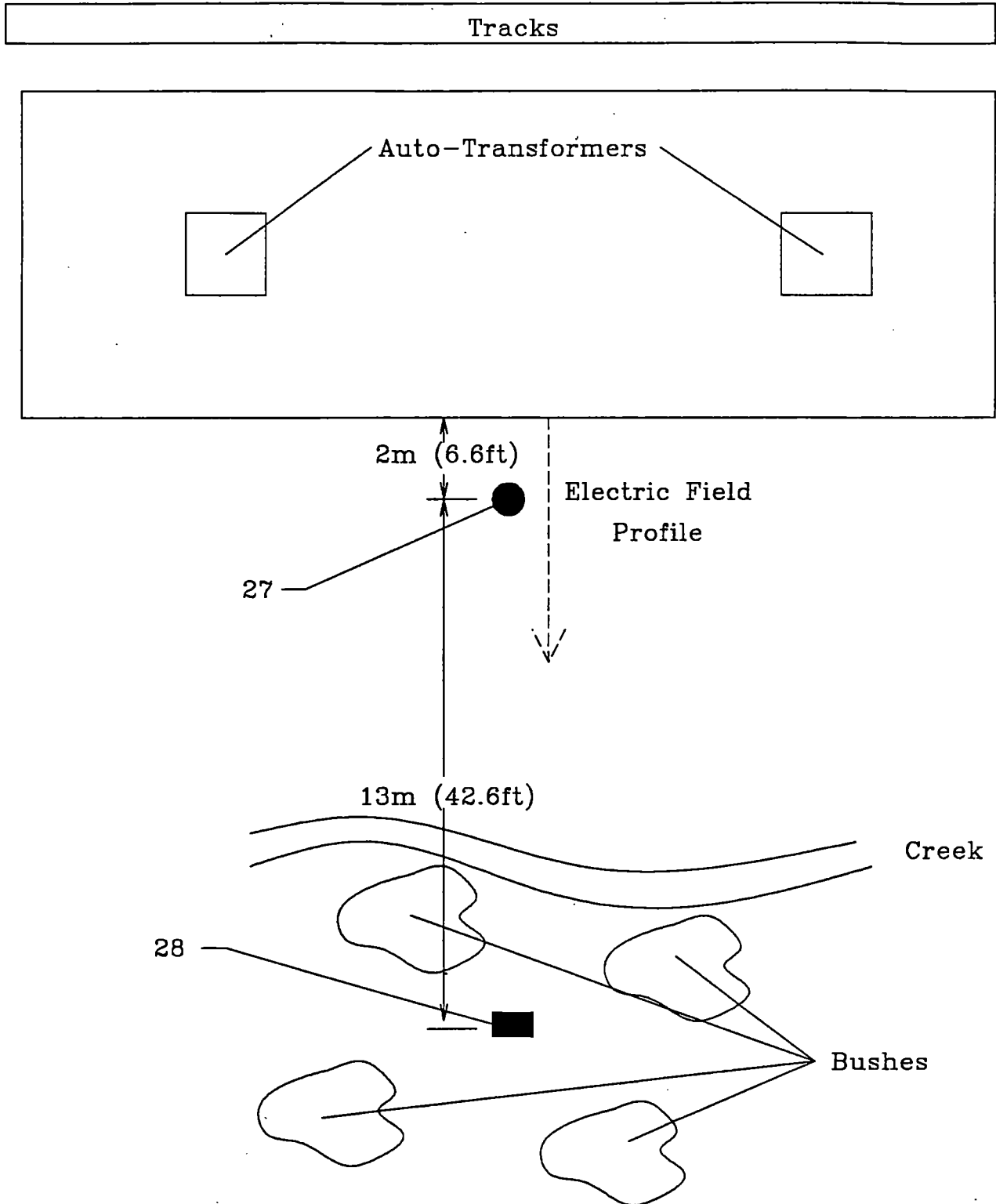

DRAWING A-6

# HIGHWAY OVERPASS

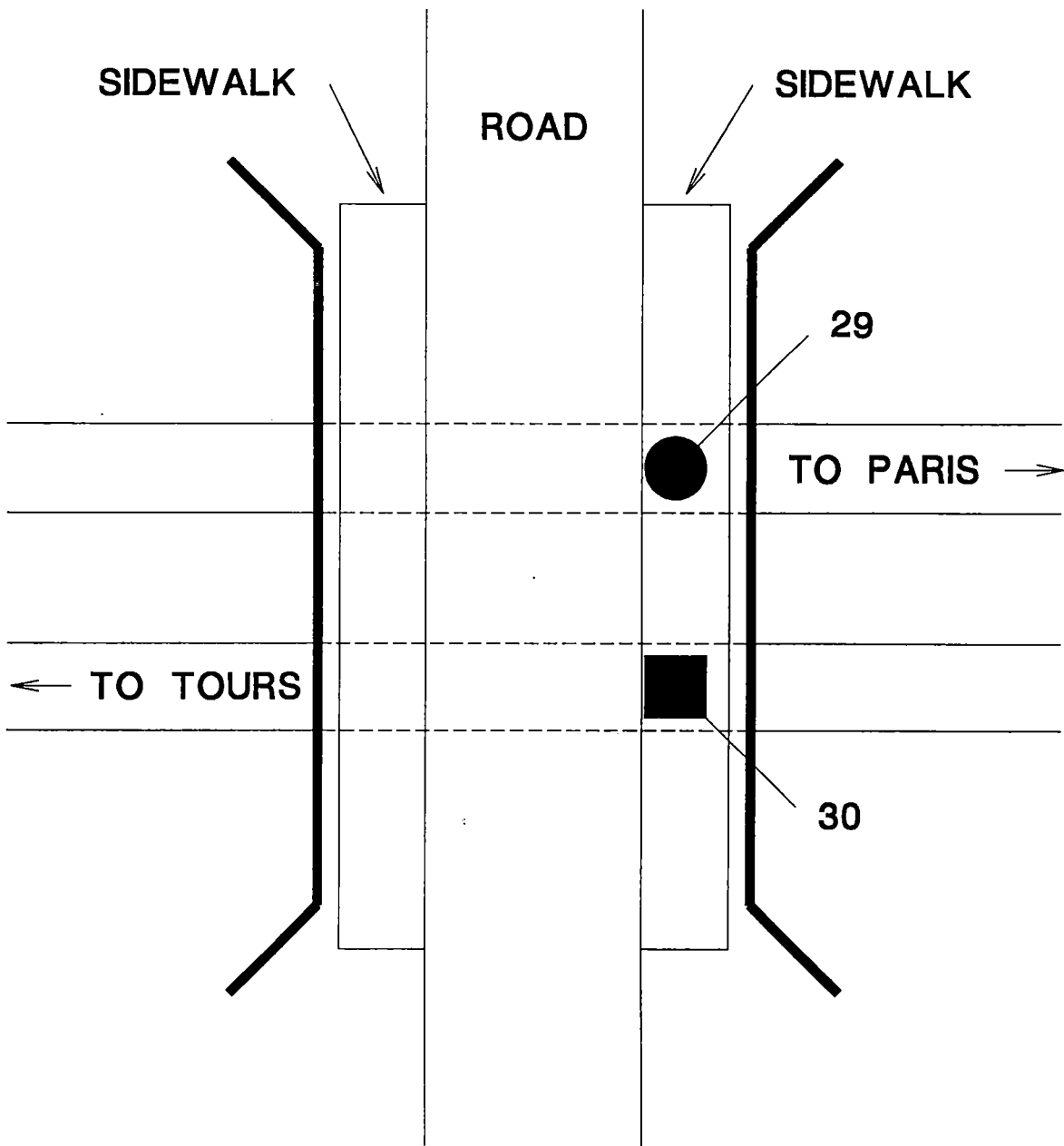

DRAWING A-7

# HIGHWAY UNDERPASS

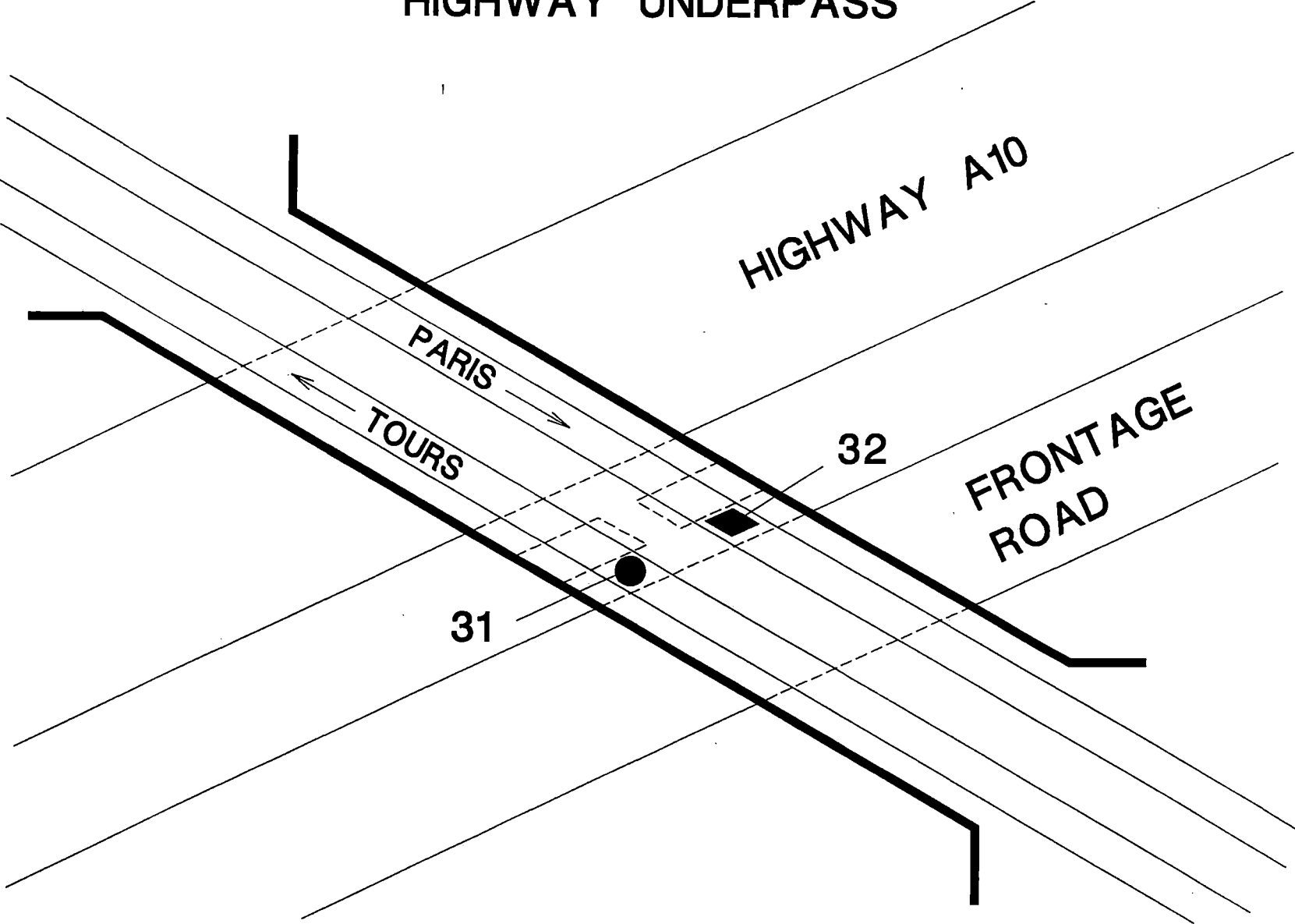

DRAWING A-8

# Wayside Measurement at Marker 104km

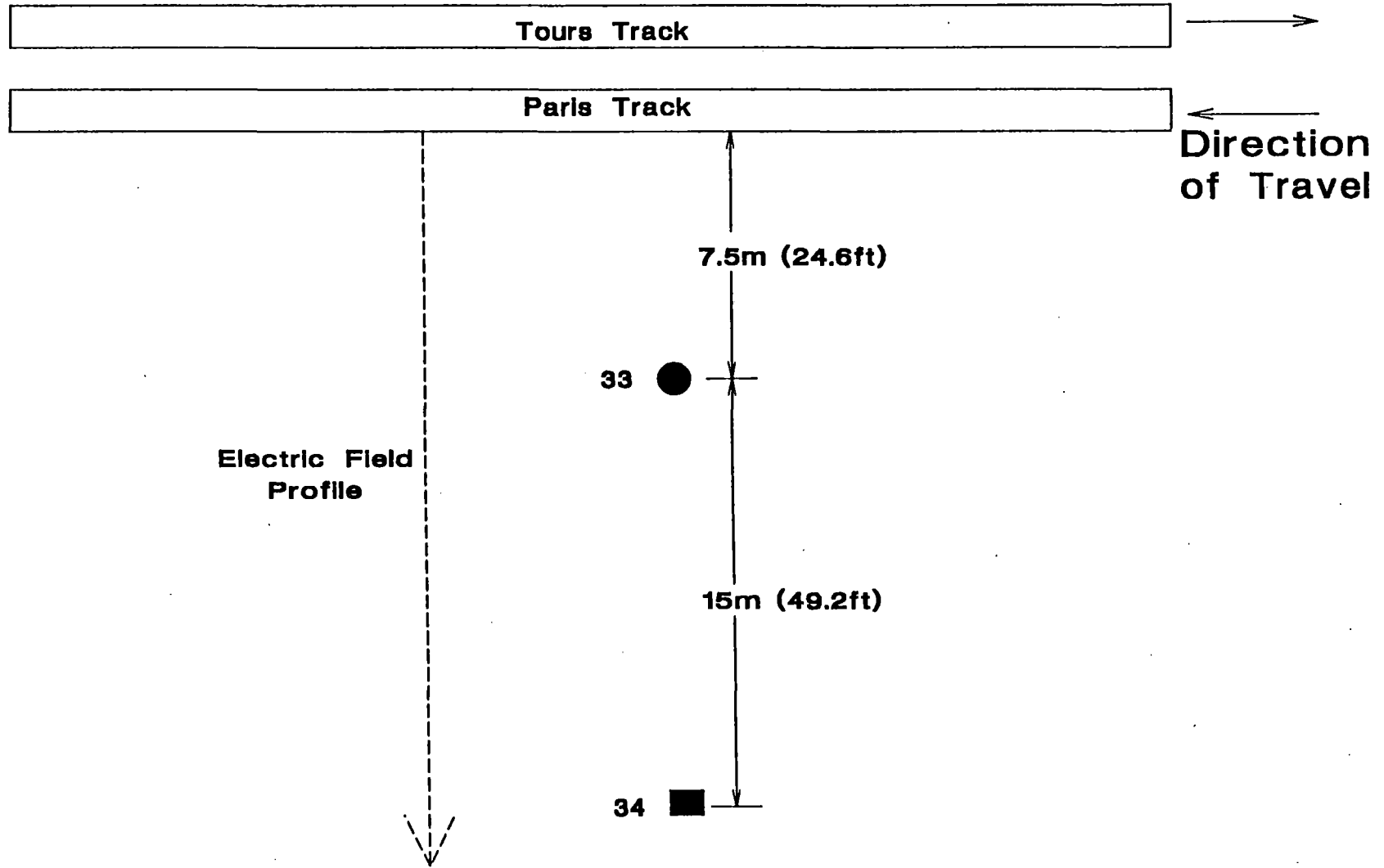

DRAWING A-9



# Gault St. Denis Substation

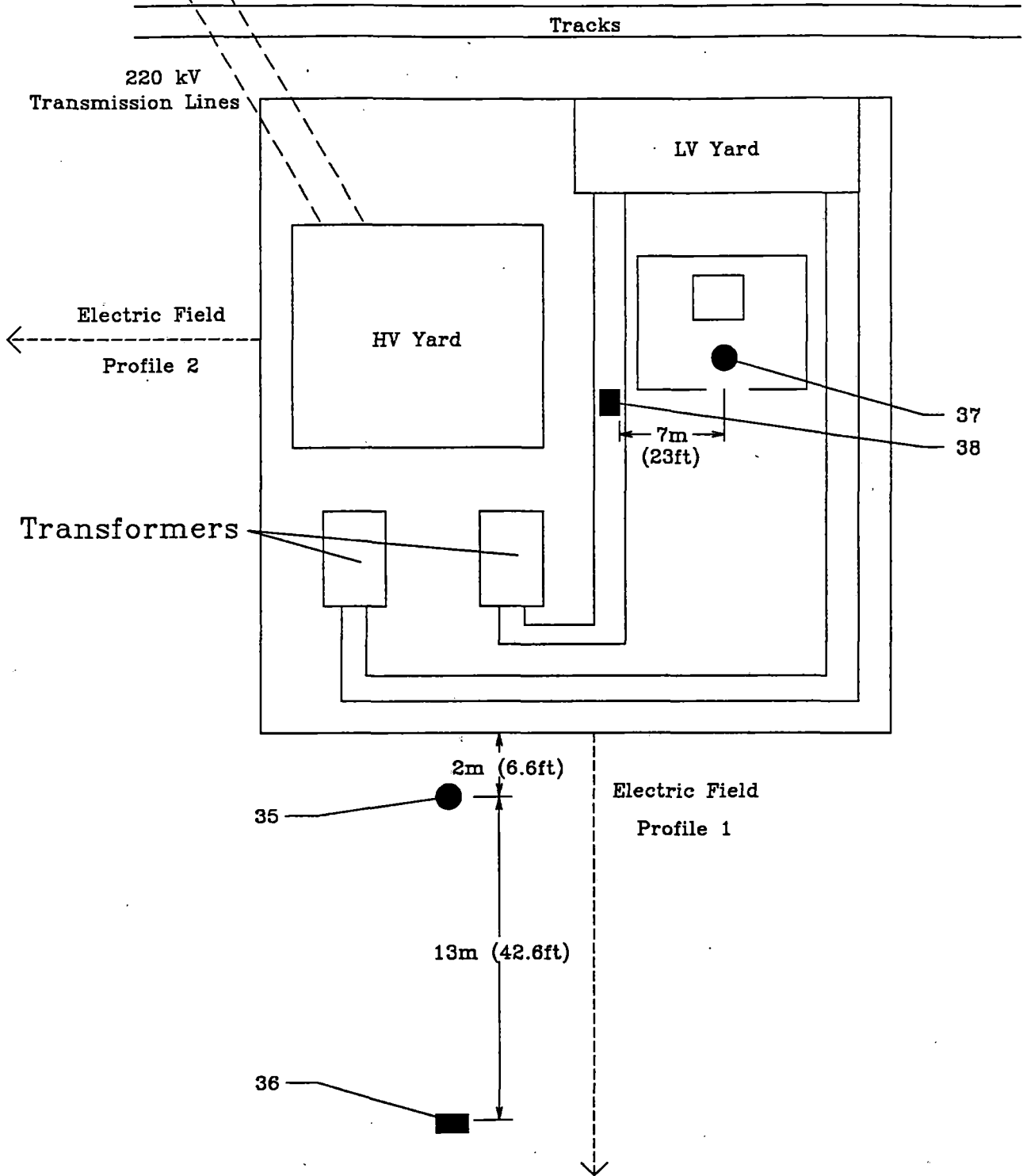

DRAWING A-10

APPENDIX B

DATASET TGV001  
FIRST CLASS SALON AT FRONT OF COACH R1B

Measurement Setup Code:        Staff: 1        Reference: 4  
   Drawing: A-1

Vehicle Status:                Coach trip from Montparnasse  
   station in Paris to Tours station

Measurement Date:              September 8, 1992

Measurement Time:              Start:        07:57:30  
   End:         08:16:30

Number of Samples:             101

Programmed Sample Interval:   10 sec

Actual Sample Interval:        11.4 sec

Frequency Spectrum Parameters

<u>Probe Type:</u>	<u>Wideband</u>	<u>Static</u>
Maximum Frequency (Hz)	2560	64
Minimum Frequency (Hz)	5	0
Spectral Bandwidth (Hz)	5	1

Missing or Suspect Data:        None

# TRAIN SPEED - TGV001

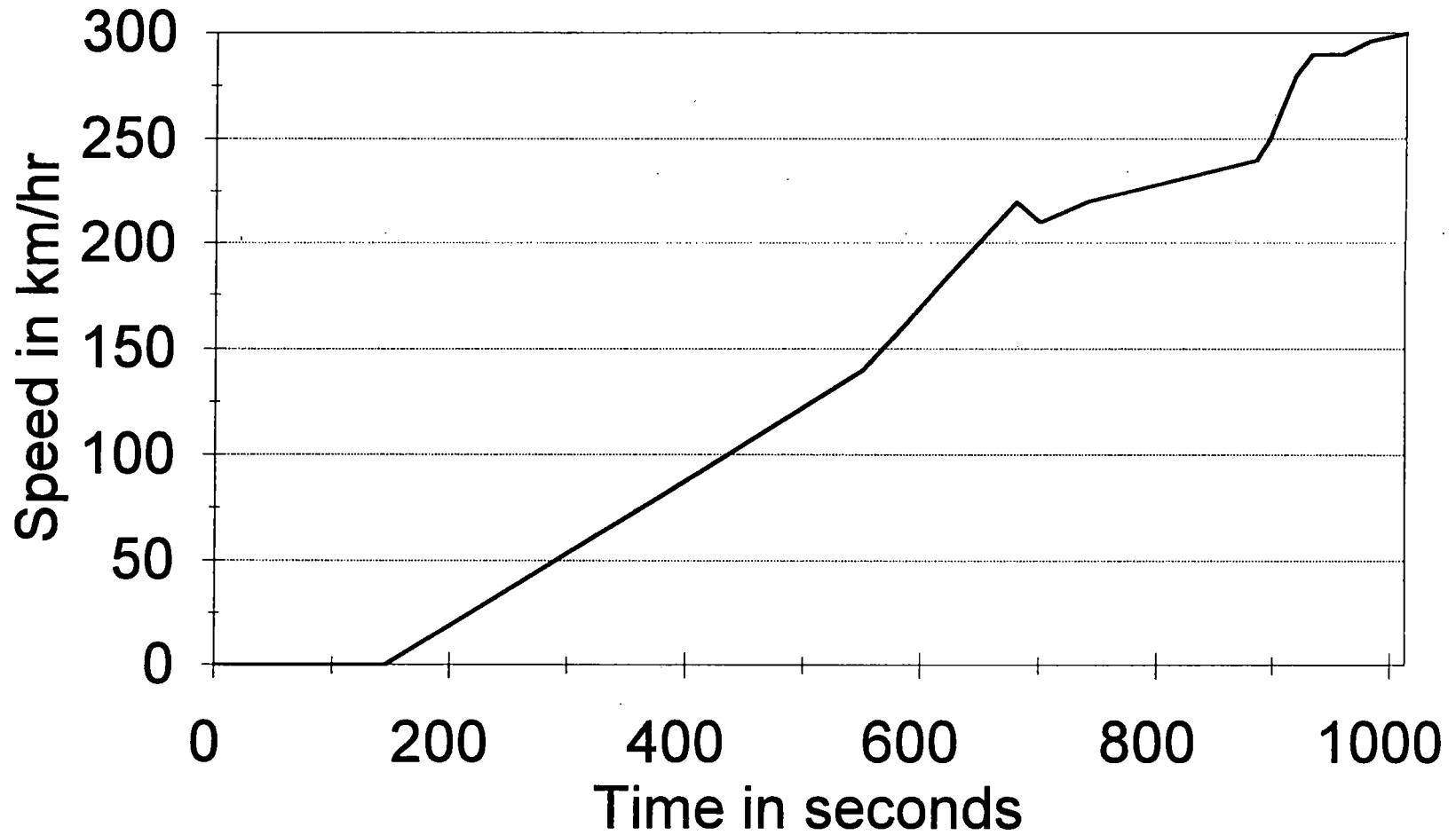

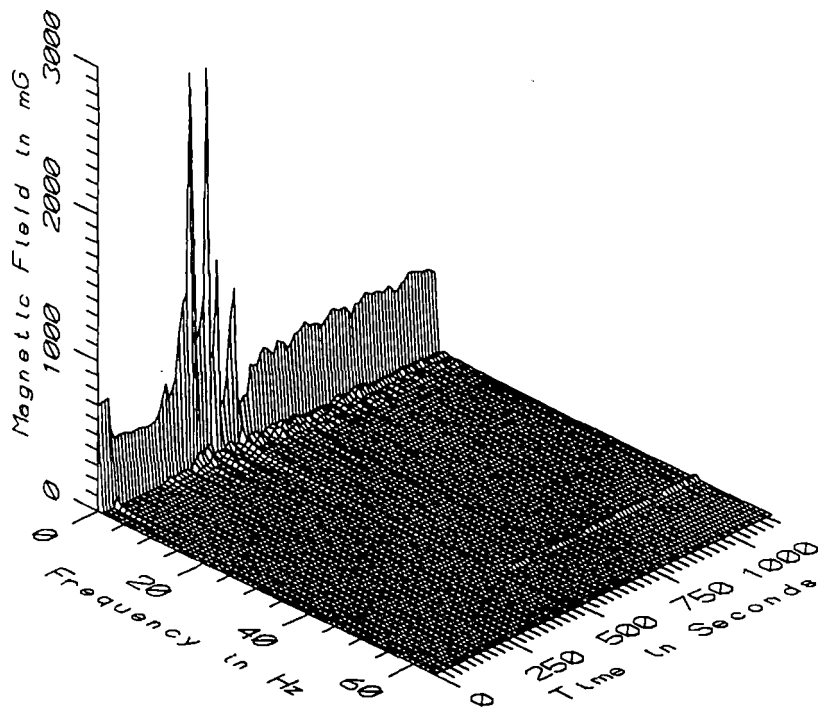

TGV001 - 10cm ABOVE FLOOR IN CENTER OF AISLE AT FRONT OF COACH R1B

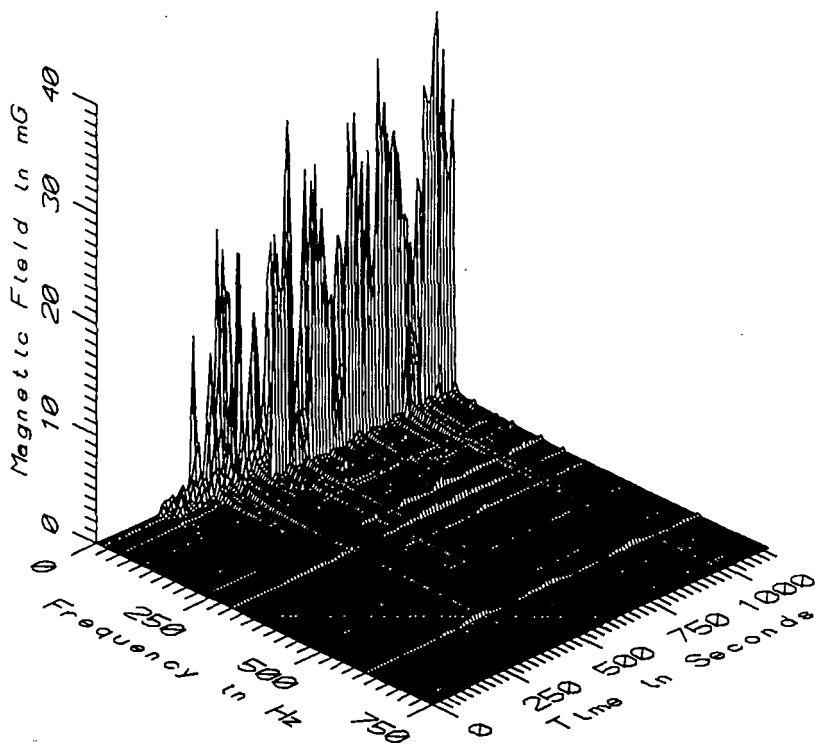

TGV001 - 10cm ABOVE FLOOR IN CENTER OF AISLE AT FRONT OF COACH R1B

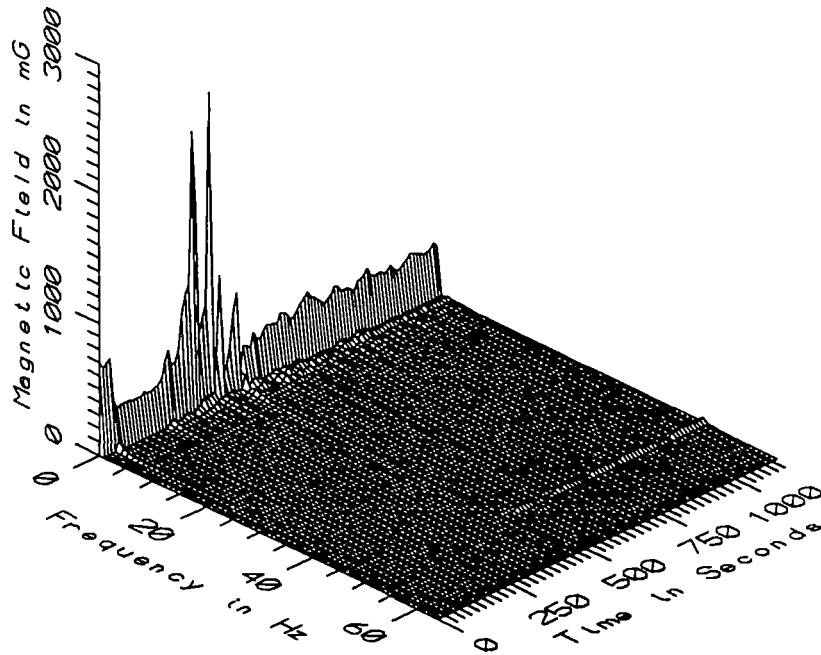

TGV001 - 60cm ABOVE FLOOR IN CENTER OF AISLE AT FRONT OF COACH R1B

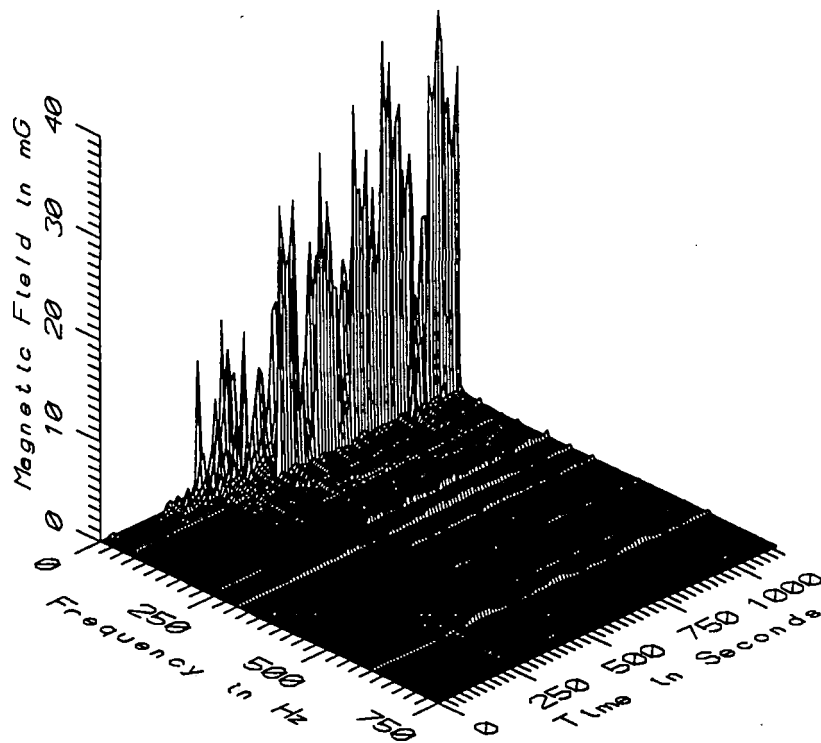

TGV001 - 60cm ABOVE FLOOR IN CENTER OF AISLE AT FRONT OF COACH R1B

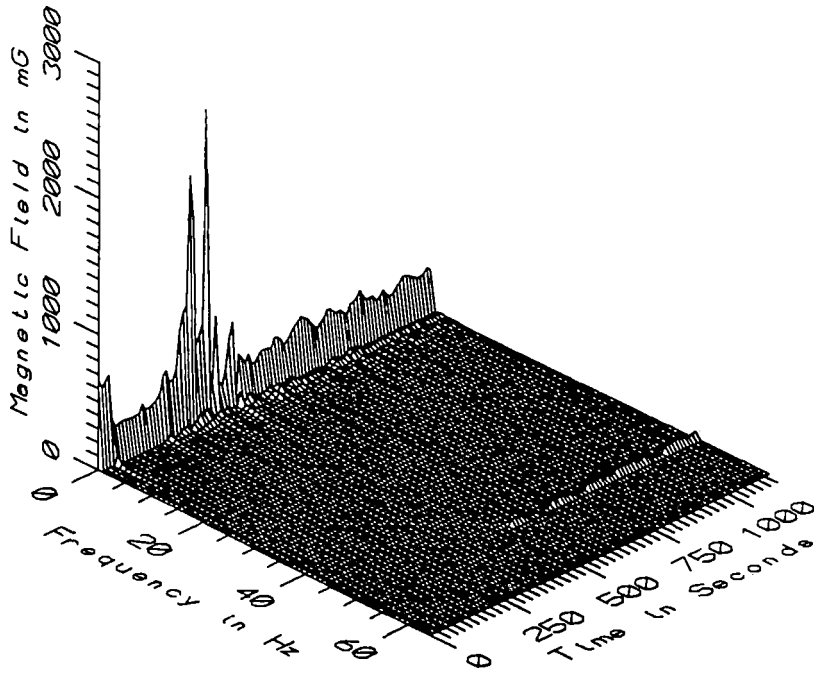

TGV001 - 110cm ABOVE FLOOR IN CENTER OF AISLE AT FRONT OF COACH R1B

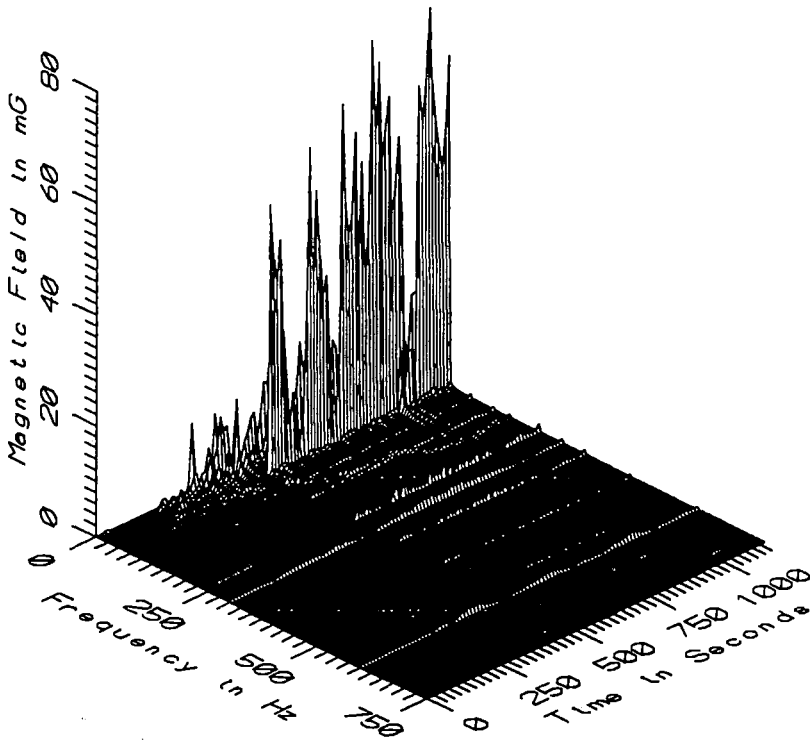

TGV001 - 110cm ABOVE FLOOR IN CENTER OF AISLE AT FRONT OF COACH R1B

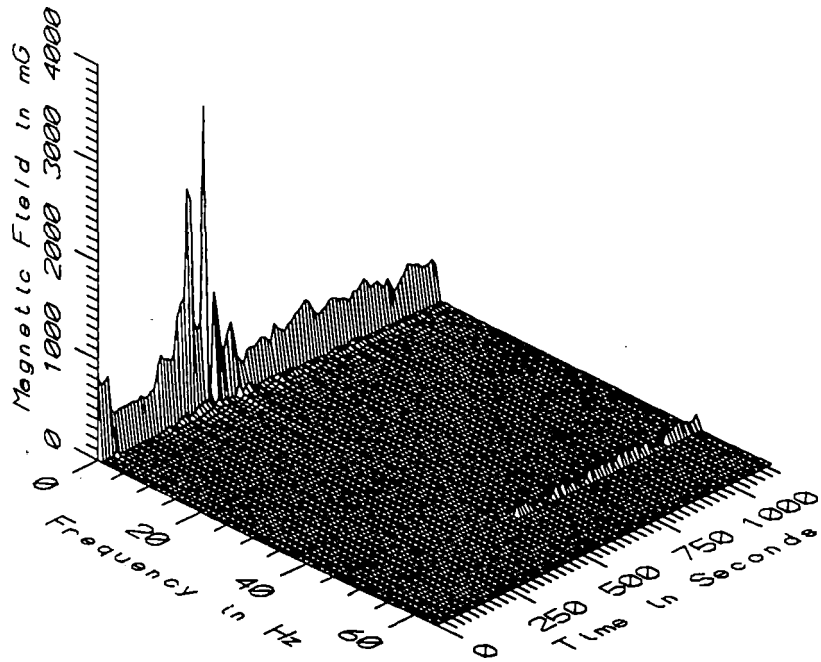

TGV001 - 160cm ABOVE FLOOR IN CENTER OF AISLE AT FRONT OF COACH R1B

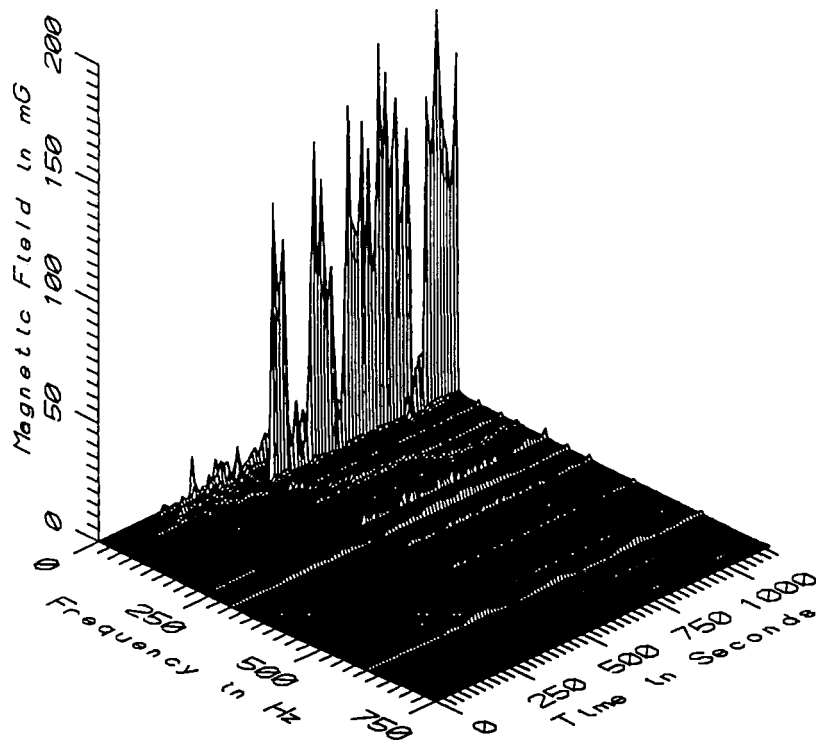

TGV001 - 160cm ABOVE FLOOR IN CENTER OF AISLE AT FRONT OF COACH R1B

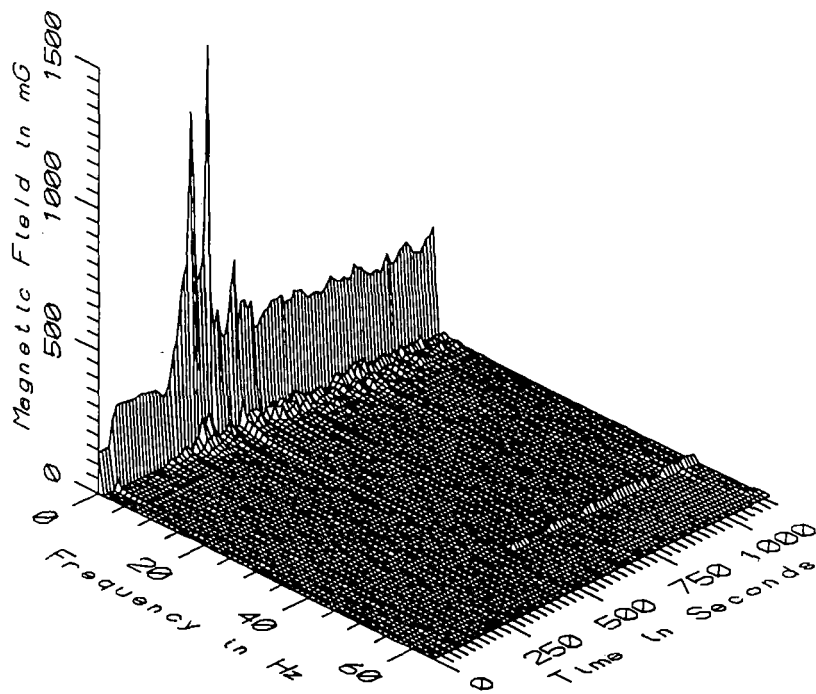

TGV001 - REFERENCE PROBE - ON CORNER SEAT AT FRONT OF COACH R1B

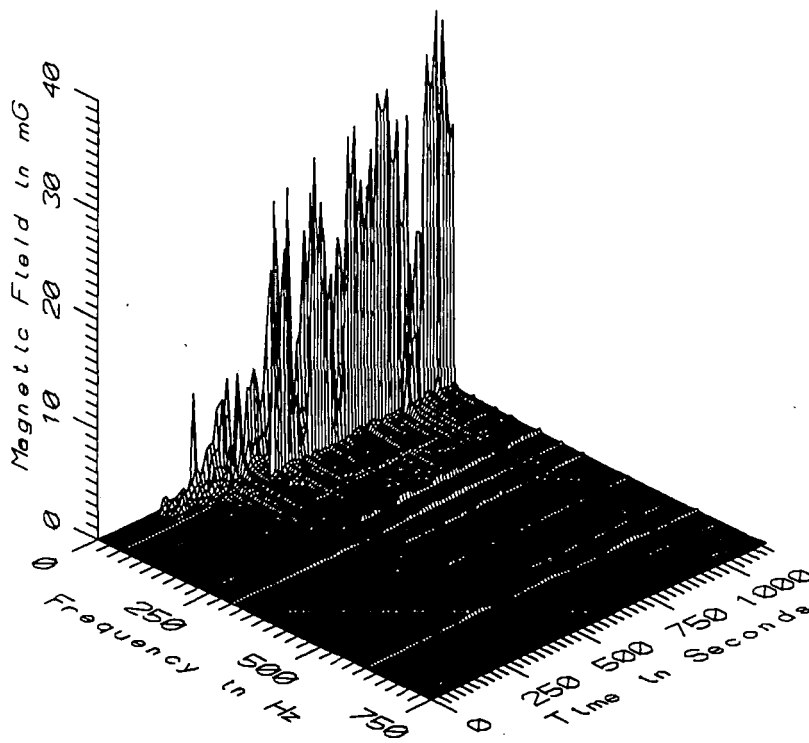

TGV001 - REFERENCE PROBE - ON CORNER SEAT AT FRONT OF COACH R1B



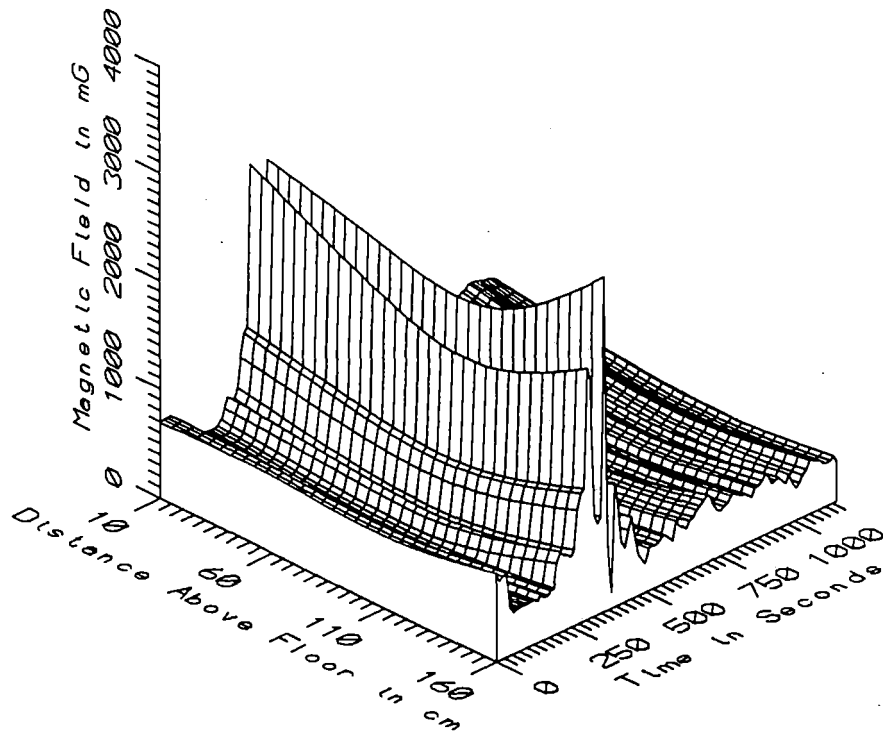

TGV001 - CENTER OF AISLE AT FRONT OF COACH R1B - STATIC

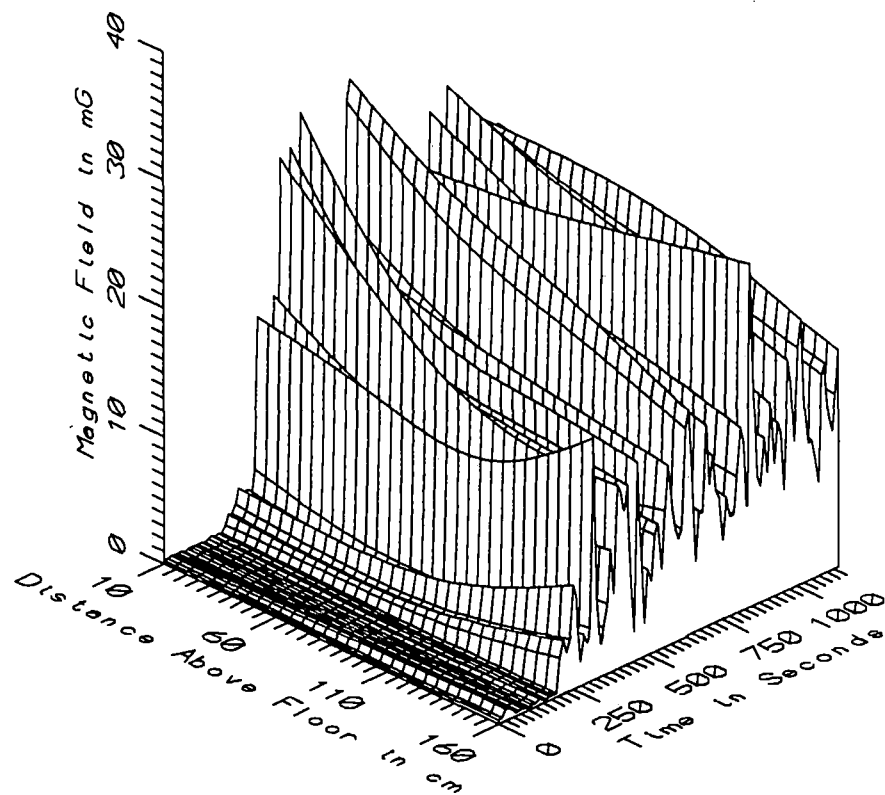

TGV001 - CENTER OF AISLE AT FRONT OF COACH R1B - LOW FREQ, 5-45Hz

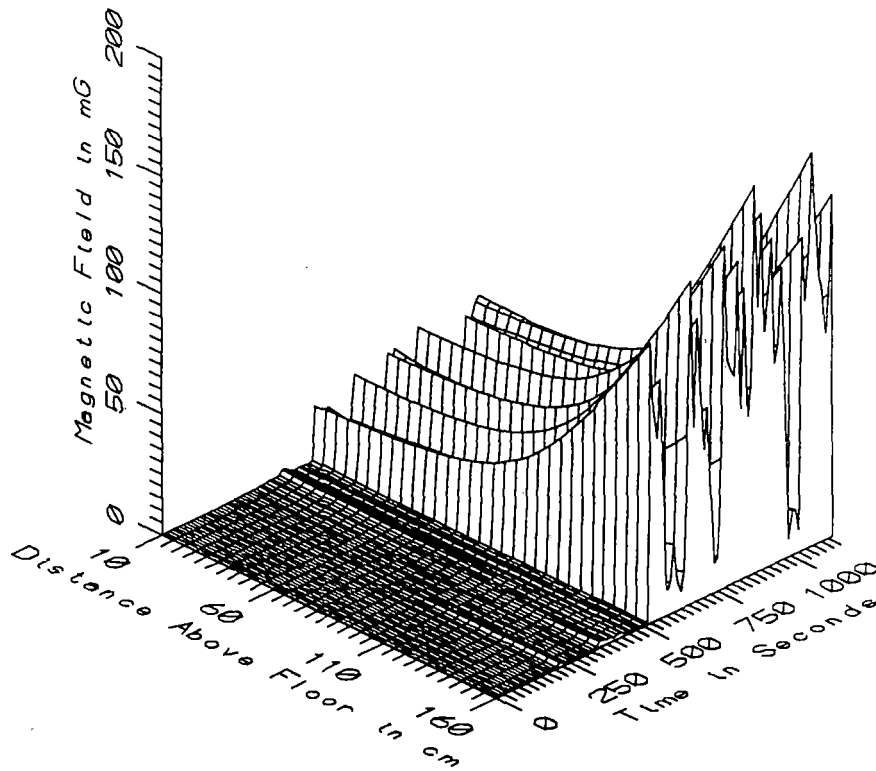

TGV001 - CENTER OF AISLE AT FRONT OF COACH R1B - POWER FREQ, 50-60Hz

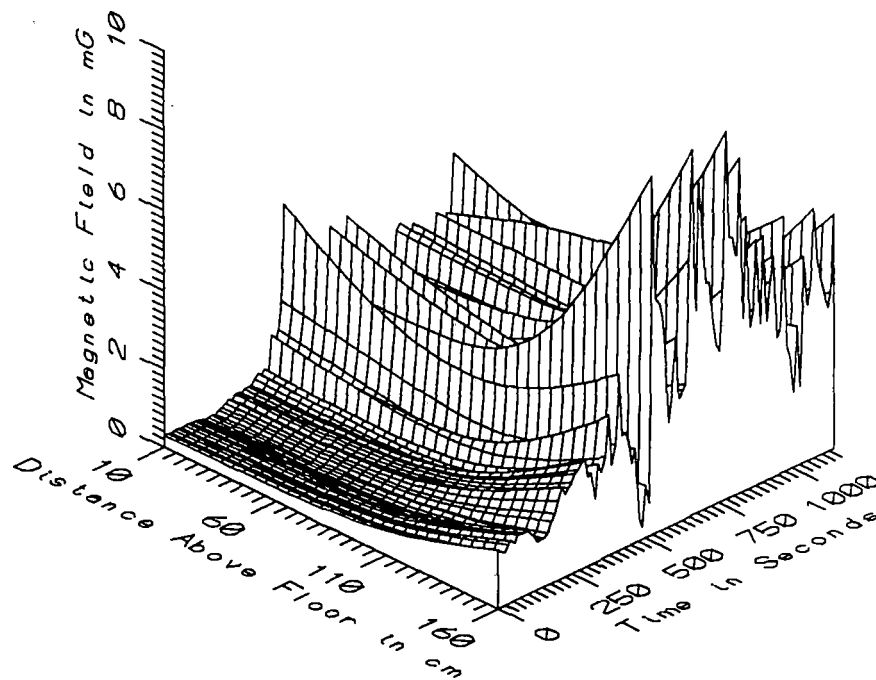

TGV001 - CENTER OF AISLE AT FRONT OF COACH R1B - POWER HARM, 65-300Hz

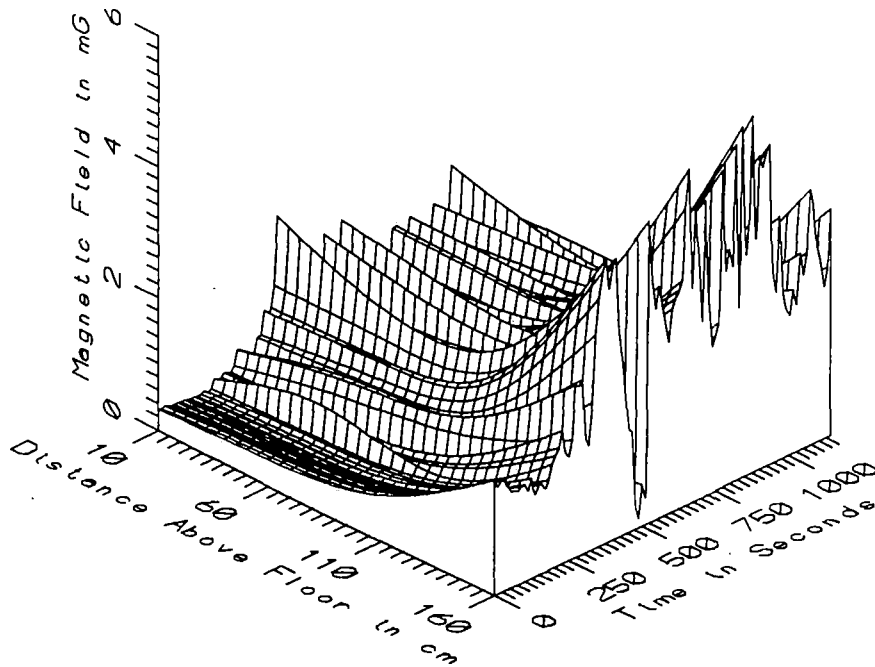

TGV001 - CENTER OF AISLE AT FRONT OF COACH R1B - HIGH FREQ, 305-2560Hz

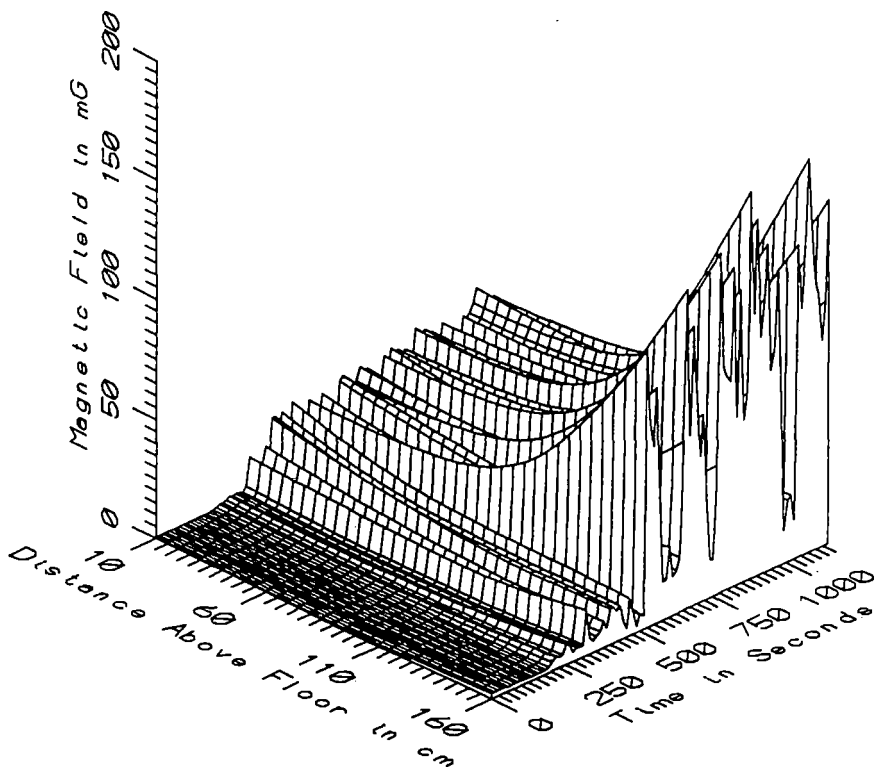

TGV001 - CENTER OF AISLE AT FRONT OF COACH R1B - ALL FREQ, 5-2560Hz

TGV001 - FRONT OF FIRST COACH, ALL SAMPLES				TOTAL OF 101 SAMPLES		
FREQUENCY BAND	HEIGHT ABOVE FLOOR (cm)	MINIMUM MAGNETIC FIELD (mG)	MAXIMUM MAGNETIC FIELD (mG)	AVERAGE MAGNETIC FIELD (mG)	STANDARD DEVIATION (mG)	COEFFICIENT OF VARIATION (%)
STATIC	10	260.98	2670.86	628.02	355.68	56.64
	60	109.82	2387.63	459.55	318.56	69.32
	110	37.37	2272.85	405.74	299.25	73.76
	160	138.85	3065.39	576.03	394.78	68.54
5-45Hz LOW FREQ	10	0.19	30.83	12.03	9.06	75.29
	60	0.17	25.34	9.84	7.43	75.51
	110	0.12	24.83	9.02	6.69	74.19
	160	0.22	26.87	8.68	5.87	67.64
50-60Hz PWR FREQ	10	0.13	35.83	10.01	11.22	112.06
	60	0.17	38.83	11.35	12.71	111.95
	110	0.16	70.13	19.79	22.65	114.43
	160	0.24	164.68	45.30	52.63	116.20
65-300Hz PWR HARM	10	0.24	4.70	1.39	0.93	67.13
	60	0.31	3.43	1.33	0.79	59.85
	110	0.40	4.24	1.77	0.95	53.88
	160	0.31	9.30	3.67	2.09	56.94
305-2560Hz HIGH FREQ	10	0.18	2.36	0.76	0.43	56.35
	60	0.19	1.70	0.81	0.36	44.76
	110	0.18	2.14	1.20	0.51	42.24
	160	0.14	5.40	2.74	1.19	43.61
5-2560Hz ALL FREQ	10	0.44	41.38	17.22	12.62	73.30
	60	0.53	40.13	16.56	13.08	78.97
	110	0.80	70.69	23.66	21.83	92.27
	160	1.88	165.02	48.73	50.81	104.27

TGV001 - TRAIN AT REST		TOTAL OF 19 SAMPLES				
FREQUENCY BAND	HEIGHT ABOVE FLOOR (cm)	MINIMUM MAGNETIC FIELD (mG)	MAXIMUM MAGNETIC FIELD (mG)	AVERAGE MAGNETIC FIELD (mG)	STANDARD DEVIATION (mG)	COEFFICIENT OF VARIATION (%)
STATIC	10	402.22	713.09	485.82	118.78	24.45
	60	293.32	702.26	390.66	155.01	39.68
	110	260.74	660.45	362.35	148.86	41.08
	160	383.93	813.05	496.20	155.65	31.37
5-45Hz LOW FREQ	10	0.19	0.84	0.37	0.14	37.09
	60	0.17	1.00	0.32	0.20	63.34
	110	0.12	1.37	0.33	0.33	98.57
	160	0.22	2.96	0.53	0.63	119.13
50-60Hz PWR FREQ	10	0.13	0.28	0.18	0.04	23.39
	60	0.17	0.36	0.24	0.06	25.83
	110	0.16	0.60	0.35	0.11	30.33
	160	0.47	0.65	0.53	0.04	7.65
65-300Hz PWR HARM	10	0.24	0.40	0.29	0.04	12.99
	60	0.31	0.45	0.38	0.04	10.47
	110	0.49	0.84	0.63	0.08	12.22
	160	1.19	2.01	1.49	0.20	13.32
305-2560Hz HIGH FREQ	10	0.20	0.35	0.26	0.04	15.04
	60	0.30	0.76	0.37	0.10	27.34
	110	0.49	0.70	0.58	0.07	11.31
	160	1.25	1.76	1.49	0.15	9.90
5-2560Hz ALL FREQ	10	0.44	1.02	0.58	0.12	20.79
	60	0.53	1.22	0.68	0.17	25.45
	110	0.80	1.82	1.02	0.23	22.25
	160	1.88	4.00	2.29	0.45	19.89

TGV001 - TRAIN MOVING			TOTAL OF 82 SAMPLES			
FREQUENCY BAND	HEIGHT ABOVE FLOOR (cm)	MINIMUM MAGNETIC FIELD (mG)	MAXIMUM MAGNETIC FIELD (mG)	AVERAGE MAGNETIC FIELD (mG)	STANDARD DEVIATION (mG)	COEFFICIENT OF VARIATION (%)
STATIC	10	260.98	2670.86	660.97	383.68	58.05
	60	109.82	2387.63	475.51	344.34	72.42
	110	37.37	2272.85	415.79	324.18	77.97
	160	138.85	3065.39	594.53	430.33	72.38
5-45Hz LOW FREQ	10	1.45	30.83	14.74	7.87	53.43
	60	1.18	25.34	12.05	6.48	53.77
	110	1.24	24.83	11.04	5.78	52.41
	160	1.94	26.87	10.57	4.83	45.64
50-60Hz PWR FREQ	10	0.25	35.83	12.29	11.29	91.88
	60	0.30	38.83	13.93	12.80	91.88
	110	0.37	70.13	24.30	22.90	94.22
	160	0.24	164.68	55.67	53.30	95.75
65-300Hz PWR HARM	10	0.36	4.70	1.65	0.85	51.90
	60	0.36	3.43	1.55	0.72	46.53
	110	0.40	4.24	2.03	0.87	42.54
	160	0.31	9.30	4.18	2.00	47.95
305-2560Hz HIGH FREQ	10	0.18	2.36	0.88	0.39	44.96
	60	0.19	1.70	0.92	0.32	35.42
	110	0.18	2.14	1.35	0.45	33.76
	160	0.14	5.40	3.03	1.14	37.74
5-2560Hz ALL FREQ	10	1.61	41.38	21.08	10.80	51.24
	60	1.41	40.13	20.24	11.76	58.11
	110	2.03	70.69	28.90	20.98	72.59
	160	2.64	165.02	59.49	50.64	85.12

TGV001 - DC SECTION ONLY			TOTAL OF 17 SAMPLES			
FREQUENCY BAND	HEIGHT ABOVE FLOOR (cm)	MINIMUM MAGNETIC FIELD (mG)	MAXIMUM MAGNETIC FIELD (mG)	AVERAGE MAGNETIC FIELD (mG)	STANDARD DEVIATION (mG)	COEFFICIENT OF VARIATION (%)
STATIC	10	530.72	2670.86	1096.78	664.41	60.58
	60	109.82	2387.63	852.09	621.15	72.90
	110	196.31	2272.85	793.22	566.98	71.48
	160	138.85	3065.39	1110.93	734.51	66.12
5-45Hz LOW FREQ	10	1.45	27.28	7.00	7.18	102.55
	60	1.18	19.29	5.22	5.37	102.91
	110	1.24	14.63	4.71	4.08	86.69
	160	1.94	19.11	6.34	4.52	71.29
50-60Hz PWR FREQ	10	0.28	1.44	0.61	0.38	61.41
	60	0.30	1.20	0.56	0.31	55.88
	110	0.37	1.22	0.76	0.27	35.04
	160	0.54	2.58	1.24	0.66	53.52
65-300Hz PWR HARM	10	0.41	2.33	0.83	0.54	65.82
	60	0.48	1.87	0.75	0.38	50.30
	110	0.64	1.65	1.06	0.24	22.66
	160	1.62	3.55	2.44	0.40	16.32
305-2560Hz HIGH FREQ	10	0.33	1.34	0.61	0.30	49.34
	60	0.38	1.32	0.75	0.31	41.45
	110	0.60	1.72	1.11	0.39	34.95
	160	1.57	4.27	2.66	1.00	37.57
5-2560Hz ALL FREQ	10	1.61	27.45	7.14	7.18	100.56
	60	1.41	19.46	5.43	5.31	97.82
	110	2.14	14.85	5.15	3.93	76.26
	160	4.20	19.32	7.71	4.13	53.63

TGV001 - TRANSITION BETWEEN DC & AC SECTIONS				TOTAL OF 10 SAMPLES		
FREQUENCY BAND	HEIGHT ABOVE FLOOR (cm)	MINIMUM MAGNETIC FIELD (mG)	MAXIMUM MAGNETIC FIELD (mG)	AVERAGE MAGNETIC FIELD (mG)	STANDARD DEVIATION (mG)	COEFFICIENT OF VARIATION (%)
STATIC	10	260.98	1057.78	471.74	269.80	57.19
	60	141.36	739.93	348.47	184.17	52.85
	110	37.37	619.50	317.31	158.85	50.06
	160	259.80	920.23	523.13	205.37	39.26
5-45Hz LOW FREQ	10	2.47	30.13	15.10	10.67	70.63
	60	2.09	19.10	9.95	6.44	64.70
	110	1.61	16.60	8.86	5.38	60.69
	160	2.34	15.63	8.86	4.88	55.09
50-60Hz PWR FREQ	10	0.25	2.86	1.09	0.99	90.86
	60	0.33	1.75	0.76	0.48	62.97
	110	0.40	1.44	0.83	0.37	44.44
	160	0.24	2.01	0.92	0.56	60.62
65-300Hz PWR HARM	10	0.36	4.70	1.55	1.37	88.21
	60	0.36	3.03	1.15	0.78	67.80
	110	0.40	2.84	1.28	0.70	54.51
	160	0.31	4.48	2.05	1.28	62.68
305-2560Hz HIGH FREQ	10	0.18	2.36	0.74	0.66	88.69
	60	0.19	1.70	0.63	0.44	68.82
	110	0.18	2.02	0.80	0.56	69.54
	160	0.14	4.20	1.65	1.35	82.24
5-2560Hz ALL FREQ	10	2.51	30.17	15.27	10.77	70.53
	60	2.16	19.15	10.08	6.48	64.33
	110	2.03	16.71	9.07	5.40	59.56
	160	2.64	15.91	9.41	5.00	53.08



TGV001 - AC SECTION ONLY			TOTAL OF 55 SAMPLES			
FREQUENCY BAND	HEIGHT ABOVE FLOOR (cm)	MINIMUM MAGNETIC FIELD (mG)	MAXIMUM MAGNETIC FIELD (mG)	AVERAGE MAGNETIC FIELD (mG)	STANDARD DEVIATION (mG)	COEFFICIENT OF VARIATION (%)
STATIC	10	468.16	616.00	560.66	34.82	6.21
	60	310.21	490.82	382.21	37.16	9.72
	110	243.42	417.22	317.03	40.04	12.63
	160	294.30	613.81	447.90	64.06	14.30
5-45Hz LOW FREQ	10	5.00	30.83	17.06	5.86	34.36
	60	4.11	25.34	14.54	5.07	34.84
	110	4.24	24.83	13.39	4.62	34.48
	160	5.70	26.87	12.19	4.01	32.85
50-60Hz PWR FREQ	10	1.93	35.83	17.93	9.61	53.60
	60	2.50	38.83	20.45	10.67	52.17
	110	3.42	70.13	35.84	19.34	53.96
	160	7.17	164.68	82.45	45.20	54.83
65-300Hz PWR HARM	10	0.80	3.90	1.92	0.64	33.32
	60	0.87	3.43	1.87	0.55	29.42
	110	1.10	4.24	2.47	0.65	26.33
	160	1.93	9.30	5.11	1.74	34.09
305-2560Hz HIGH FREQ	10	0.43	1.92	0.98	0.31	31.55
	60	0.54	1.57	1.02	0.25	24.80
	110	0.93	2.14	1.52	0.33	21.98
	160	2.09	5.40	3.39	0.91	26.77
5-2560Hz ALL FREQ	10	10.99	41.38	26.45	6.61	24.98
	60	9.50	40.13	26.66	7.87	29.52
	110	9.23	70.69	39.85	16.68	41.86
	160	14.29	165.02	84.61	43.43	51.33

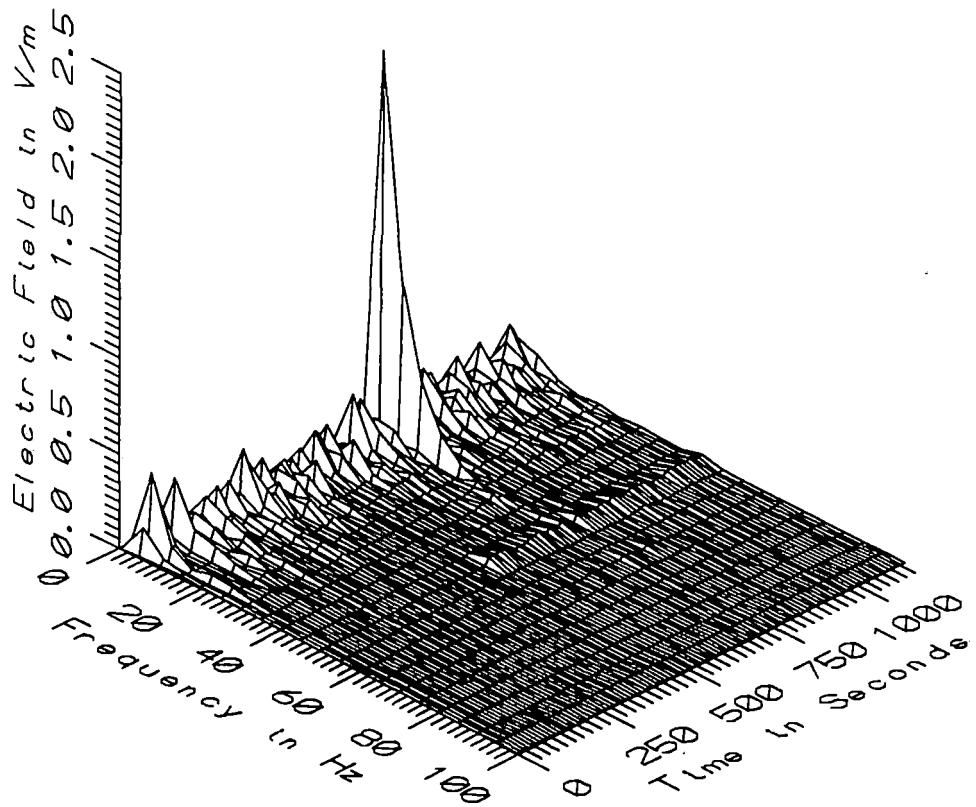

TGV001 - ELECTRIC FIELD IN COACH R1B

APPENDIX C

DATASET TGV002  
FIRST CLASS SALON AT FRONT OF COACH R1B

Measurement Setup Code:           Staff: 1           Reference: 4  
  Drawing: A-1

Vehicle Status:                   Coach trip from Montparnasse  
  station in Paris to Tours station

Measurement Date:                September 8, 1992

Measurement Time:                Start:       08:17:38  
  End:         08:21:35

Number of Samples:                9

Programmed Sample Interval:      30 sec

Actual Sample Interval:          29.6 sec

Frequency Spectrum Parameters

<u>Probe Type:</u>	<u>Wideband</u>	<u>Static</u>
Maximum Frequency (Hz)	2560	64
Minimum Frequency (Hz)	5	0
Spectral Bandwidth (Hz)	5	1

Missing or Suspect Data:       None

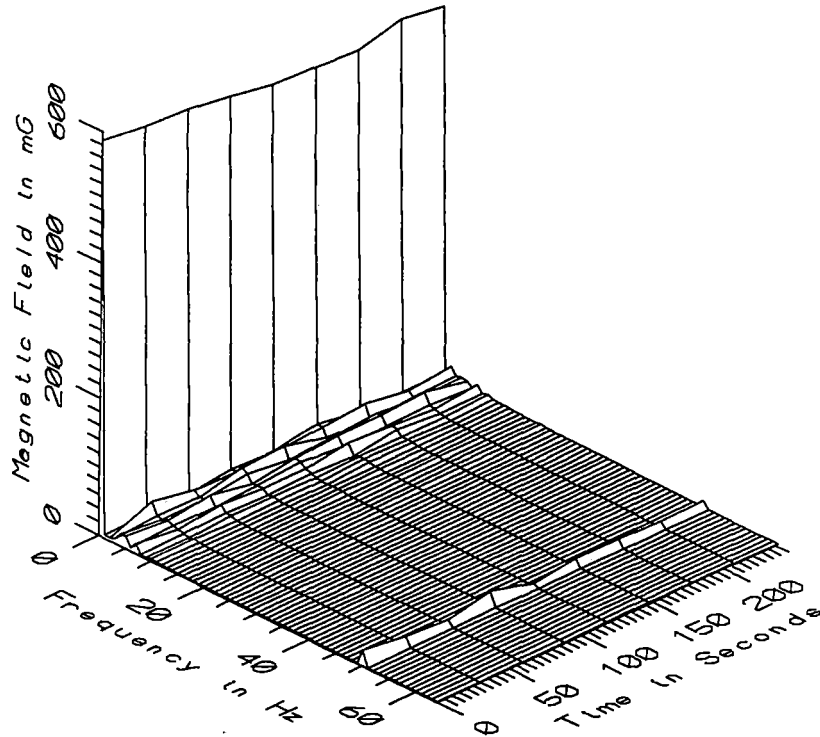

TGV002 - 10cm ABOVE FLOOR IN CENTER OF AISLE AT FRONT OF COACH R1B

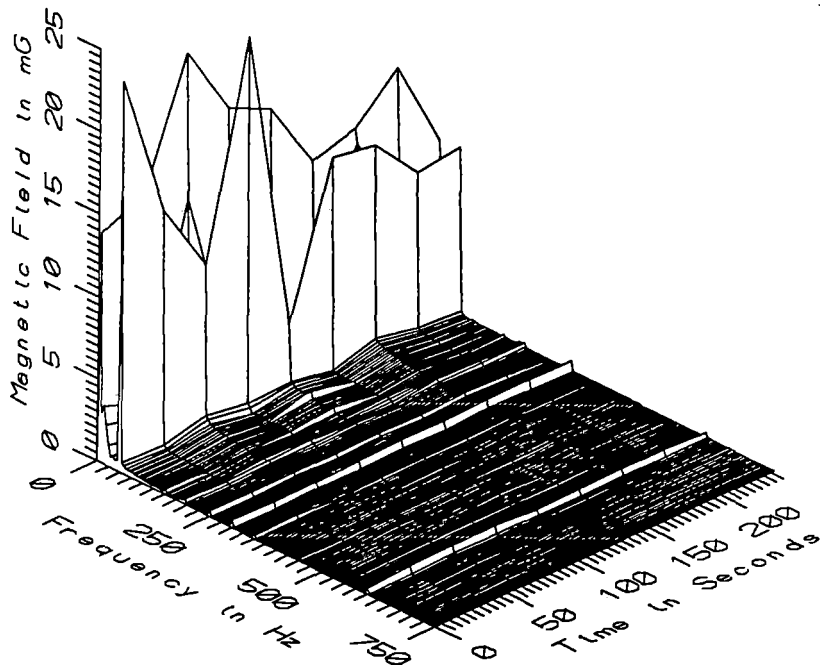

TGV002 - 10cm ABOVE FLOOR IN CENTER OF AISLE AT FRONT OF COACH R1B

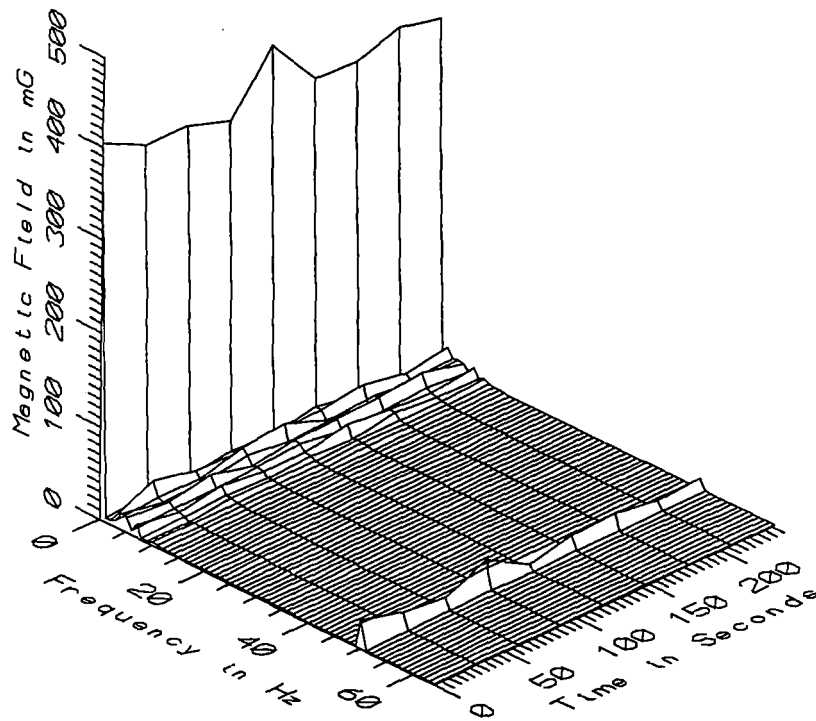

TGV002 - 60cm ABOVE FLOOR IN CENTER OF AISLE AT FRONT OF COACH R1B

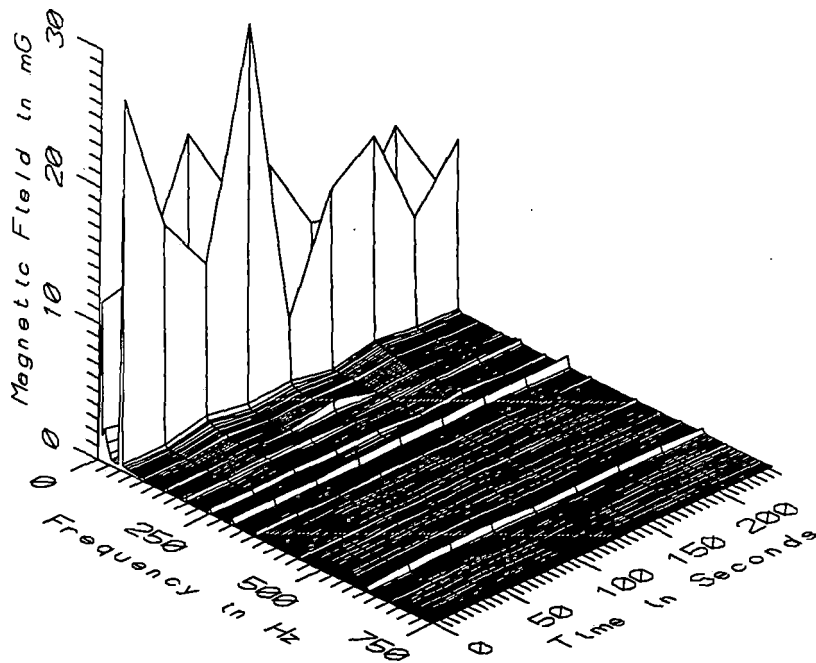

TGV002 - 60cm ABOVE FLOOR IN CENTER OF AISLE AT FRONT OF COACH R1B

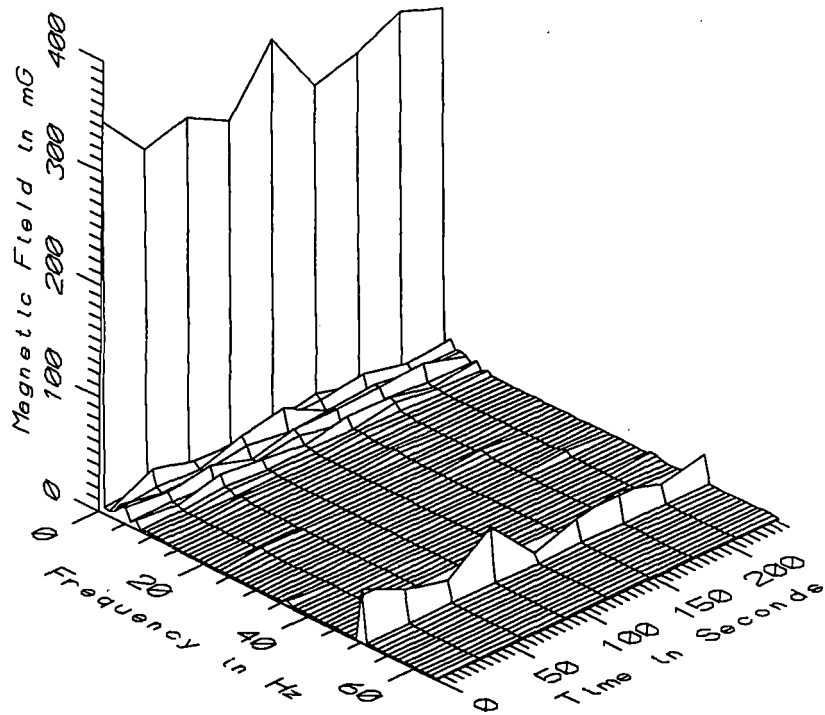

TGV002 - 110cm ABOVE FLOOR IN CENTER OF AISLE AT FRONT OF COACH R1B

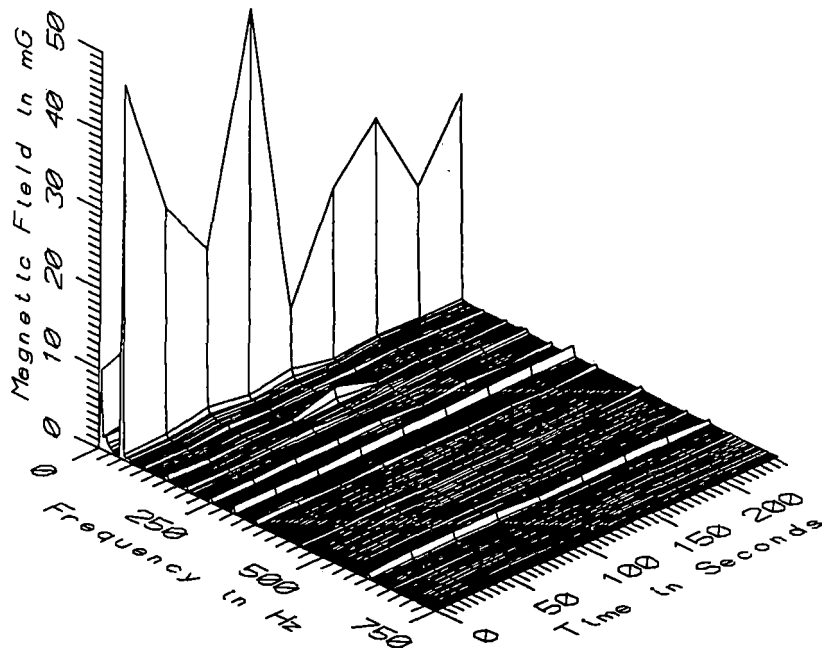

TGV002 - 110cm ABOVE FLOOR IN CENTER OF AISLE AT FRONT OF COACH R1B

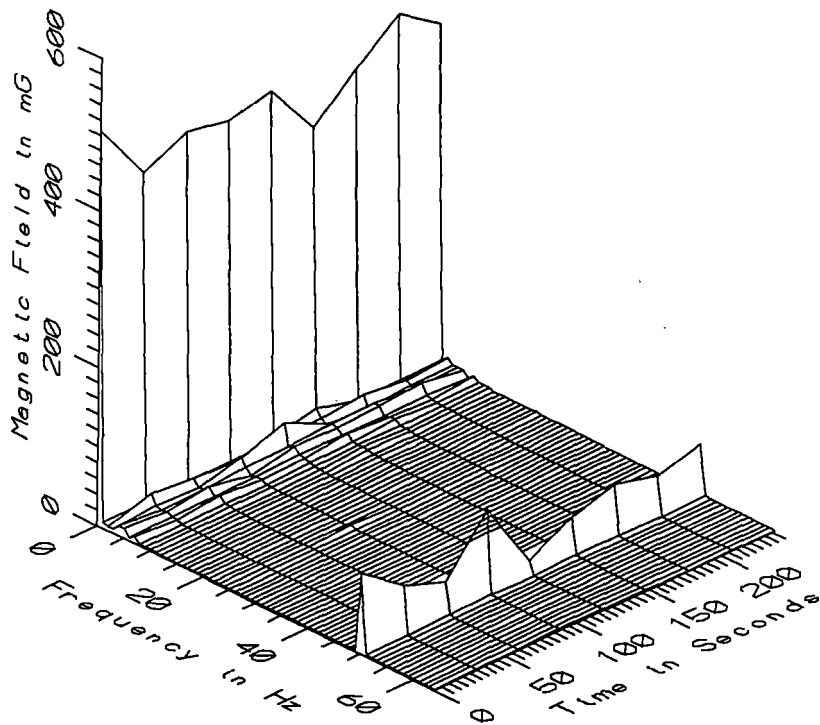

TGV002 - 160cm ABOVE FLOOR IN CENTER OF AISLE AT FRONT OF COACH R1B

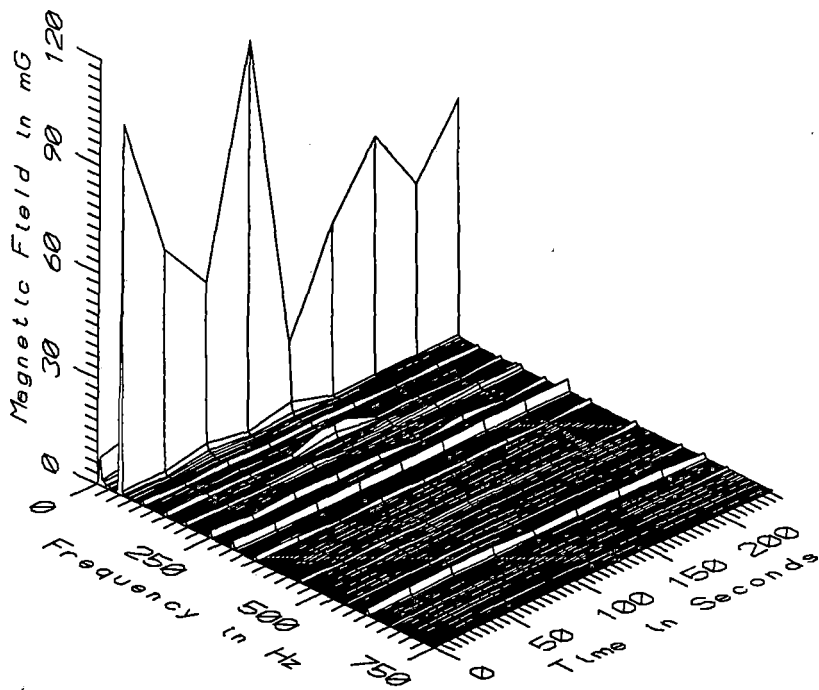

TGV002 - 160cm ABOVE FLOOR IN CENTER OF AISLE AT FRONT OF COACH R1B

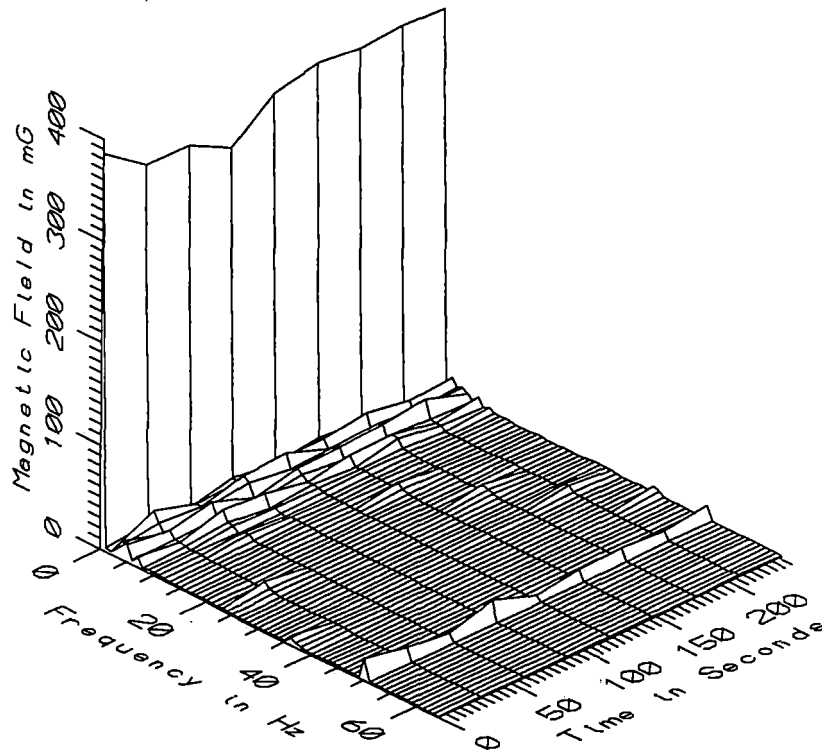

TGV002 - REFERENCE PROBE - ON CORNER SEAT AT FRONT OF COACH R1B

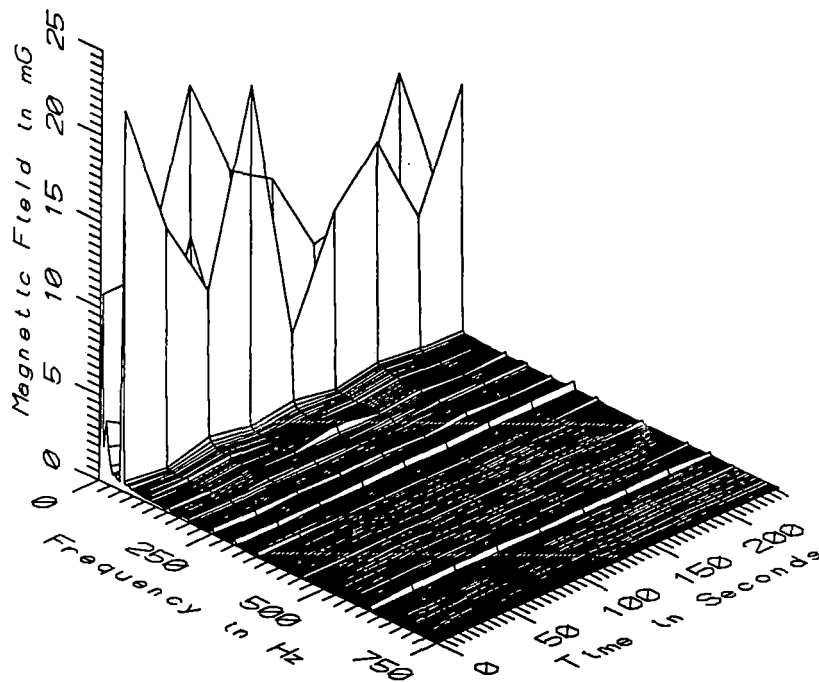

TGV002 - REFERENCE PROBE - ON CORNER SEAT AT FRONT OF COACH R1B



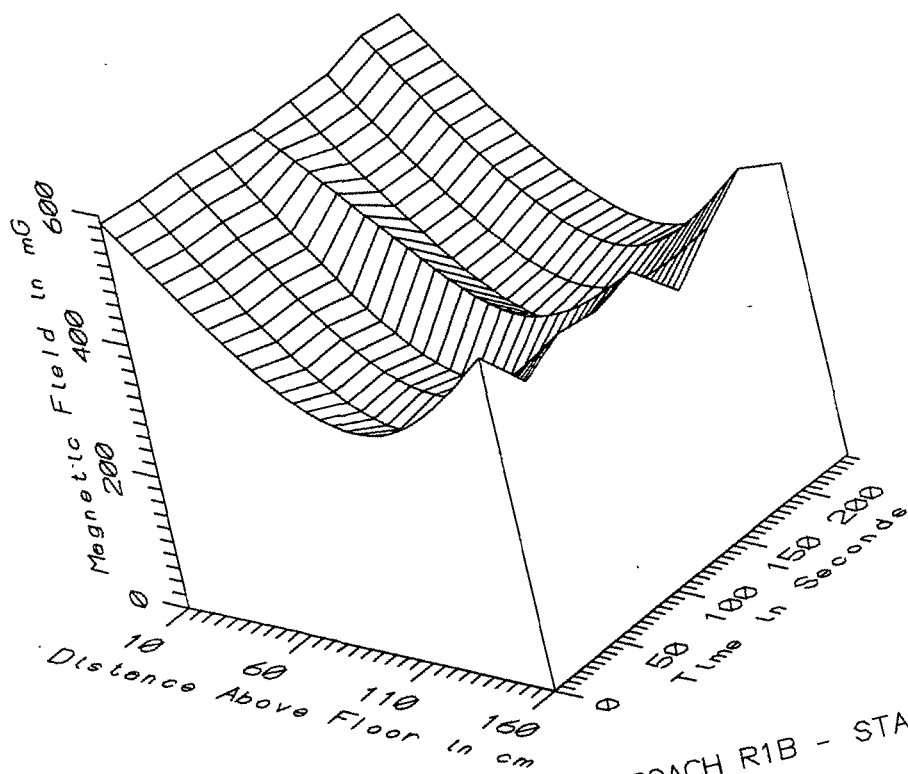

TGV002 - CENTER OF AISLE AT FRONT OF COACH R1B - STATIC

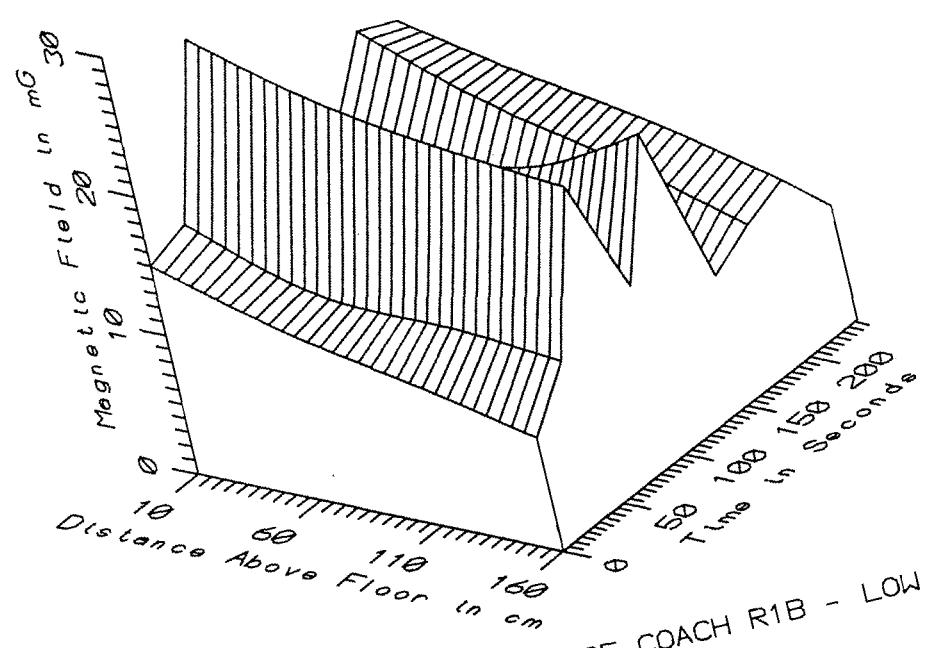

TGV002 - CENTER OF AISLE AT FRONT OF COACH R1B - LOW FREQ. 5-45Hz

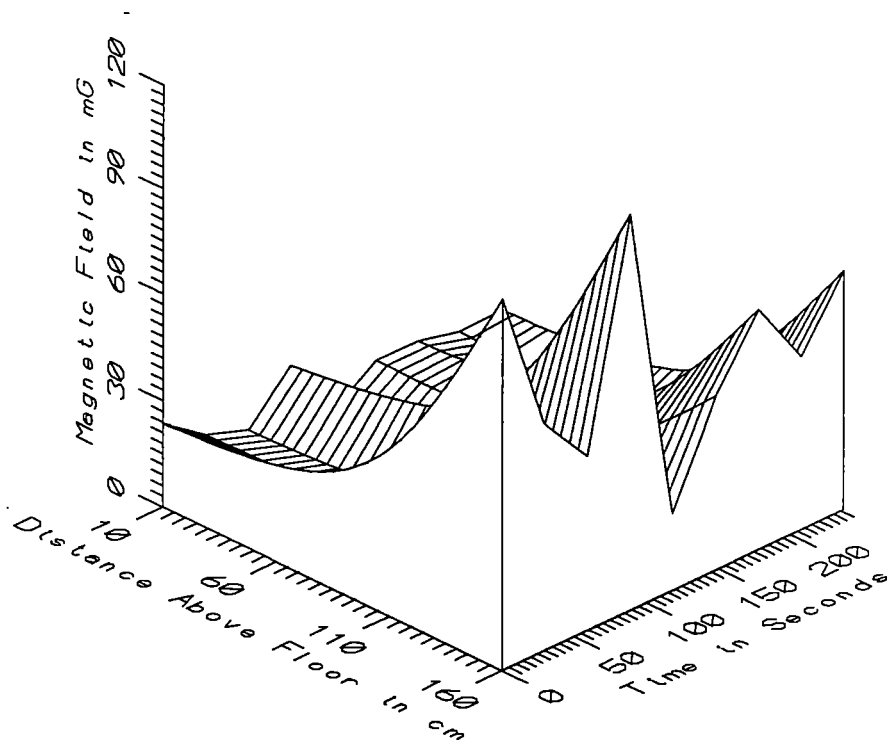

TGV002 - CENTER OF AISLE AT FRONT OF COACH R1B - POWER FREQ, 50-60Hz

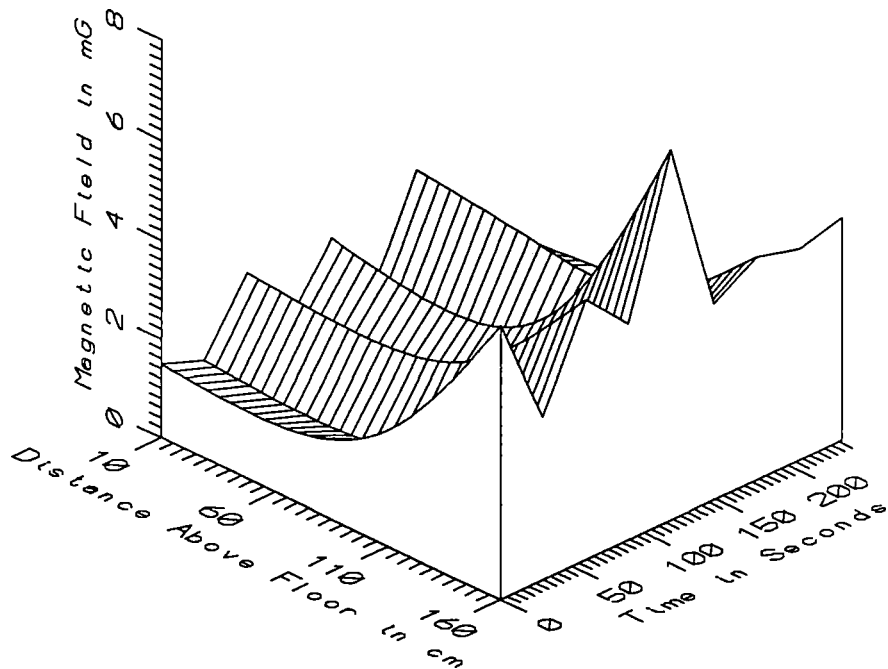

TGV002 - CENTER OF AISLE AT FRONT OF COACH R1B - POWER HARM, 65-300Hz

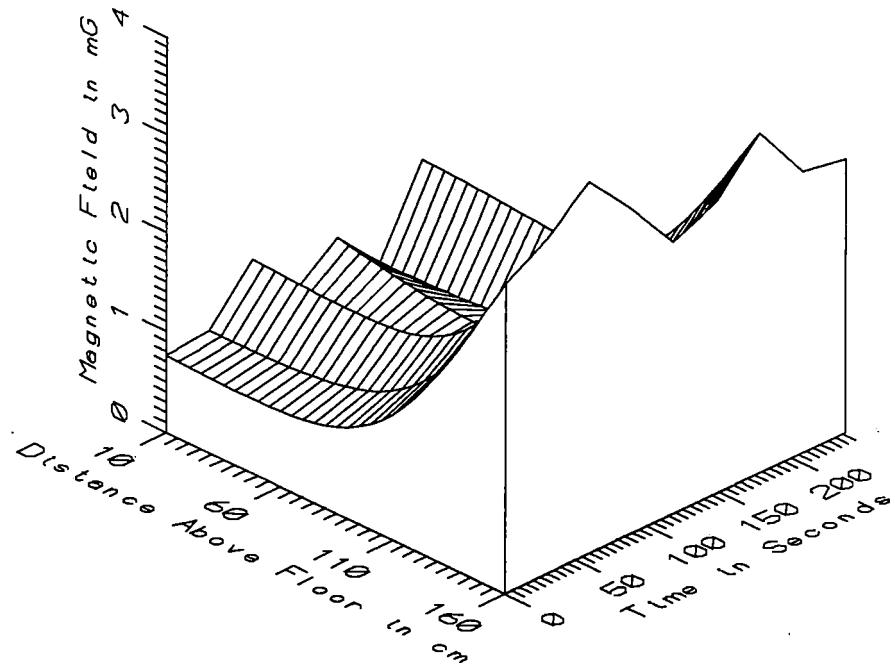

TGV002 - CENTER OF AISLE AT FRONT OF COACH R1B - HIGH FREQ, 305-2560Hz

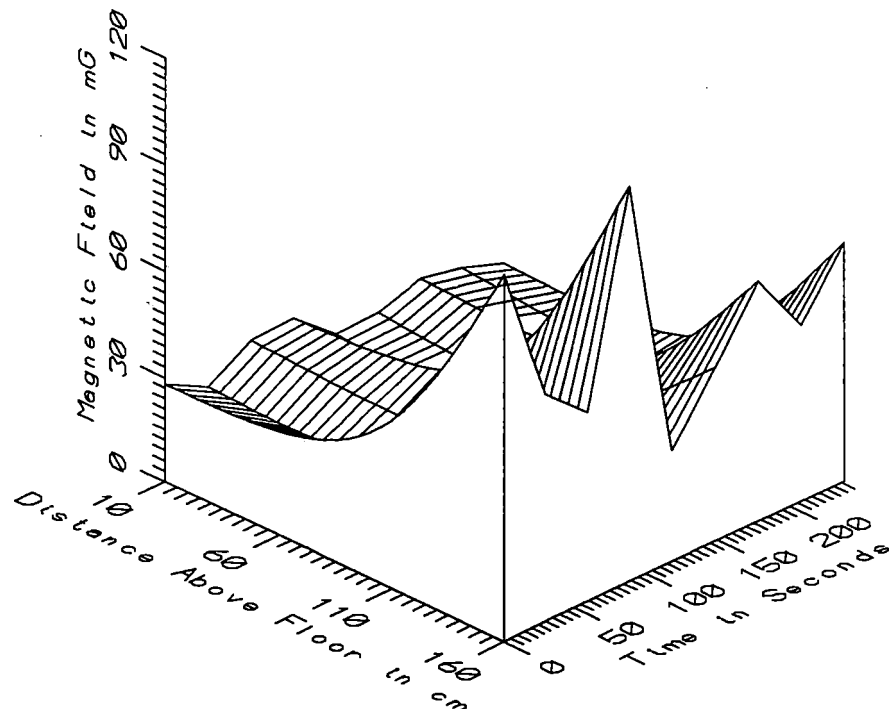

TGV002 - CENTER OF AISLE AT FRONT OF COACH R1B - ALL FREQ, 5-2560Hz

TGV002 - FIRST COACH, ALL SAMPLES IN AC SECTION				TOTAL OF 9 SAMPLES		
FREQUENCY BAND	HEIGHT ABOVE FLOOR (cm)	MINIMUM MAGNETIC FIELD (mG)	MAXIMUM MAGNETIC FIELD (mG)	AVERAGE MAGNETIC FIELD (mG)	STANDARD DEVIATION (mG)	COEFFICIENT OF VARIATION (%)
STATIC	10	549.60	588.14	566.11	13.34	2.36
	60	364.83	427.84	383.88	20.25	5.27
	110	291.87	350.64	314.89	20.99	6.66
	160	385.14	506.17	447.91	33.93	7.58
5-45Hz LOW FREQ	10	12.33	27.11	17.66	4.23	23.95
	60	10.56	24.55	15.16	4.21	27.77
	110	9.41	23.15	13.95	4.29	30.77
	160	8.24	22.36	13.21	5.35	40.50
50-60Hz PWR FREQ	10	4.50	23.74	13.58	6.23	45.87
	60	5.41	28.33	15.59	7.70	49.38
	110	9.15	49.41	27.72	13.16	47.48
	160	21.61	111.77	64.92	28.32	43.62
65-300Hz PWR HARM	10	0.97	2.99	1.69	0.75	44.13
	60	1.04	2.72	1.62	0.62	38.47
	110	1.52	3.16	2.24	0.59	26.35
	160	3.32	7.49	4.82	1.20	24.86
305-2560Hz HIGH FREQ	10	0.43	1.52	0.91	0.34	37.52
	60	0.63	1.45	0.93	0.27	28.45
	110	1.10	1.76	1.39	0.23	16.38
	160	2.72	3.74	3.12	0.35	11.19
5-2560Hz ALL FREQ	10	16.02	29.56	23.02	4.88	21.21
	60	16.53	32.45	22.68	5.88	25.94
	110	20.11	51.39	32.17	10.93	33.97
	160	31.85	112.66	67.47	26.19	38.81

APPENDIX D

DATASET TGV003  
AXIAL PROFILE IN FIRST CLASS SALON AT FRONT OF COACH R1B

Measurement Setup Code:        Staff: 2        Reference: 4  
   Drawing: A-1

Vehicle Status:                Coach trip from Montparnasse  
   station in Paris to Tours station

Measurement Date:              September 8, 1992

Measurement Time:              Start:        08:22:32  
   End:         08:27:02

Number of Samples:             10

Programmed Sample Interval:   30 sec

Actual Sample Interval:        30 sec

Frequency Spectrum Parameters

<u>Probe Type:</u>	<u>Wideband</u>	<u>Static</u>
Maximum Frequency (Hz)	2560	64
Minimum Frequency (Hz)	5	0
Spectral Bandwidth (Hz)	5	1

Missing or Suspect Data:        None

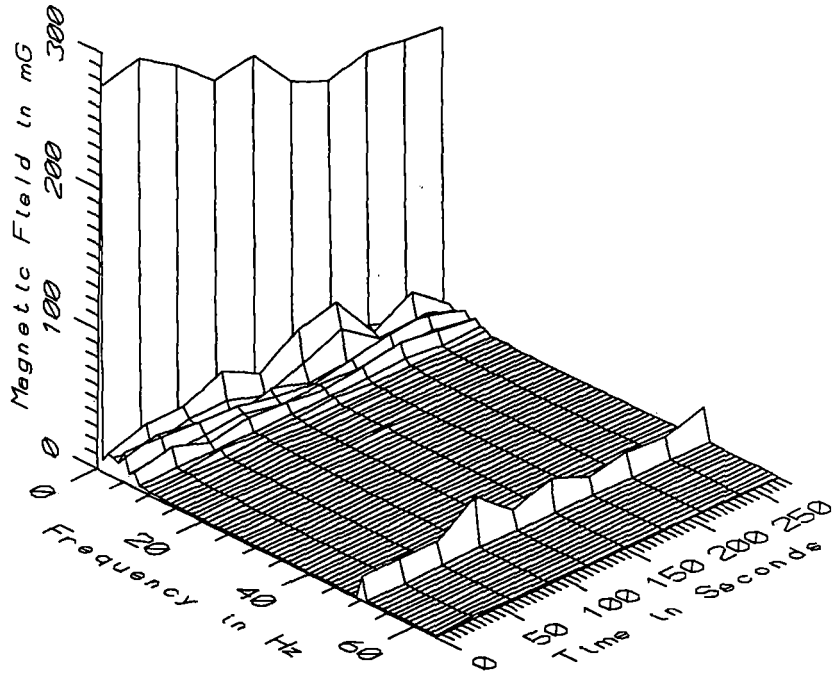

TGV003 - 10cm FROM CENTER OF DOOR AT FRONT OF COACH R1B

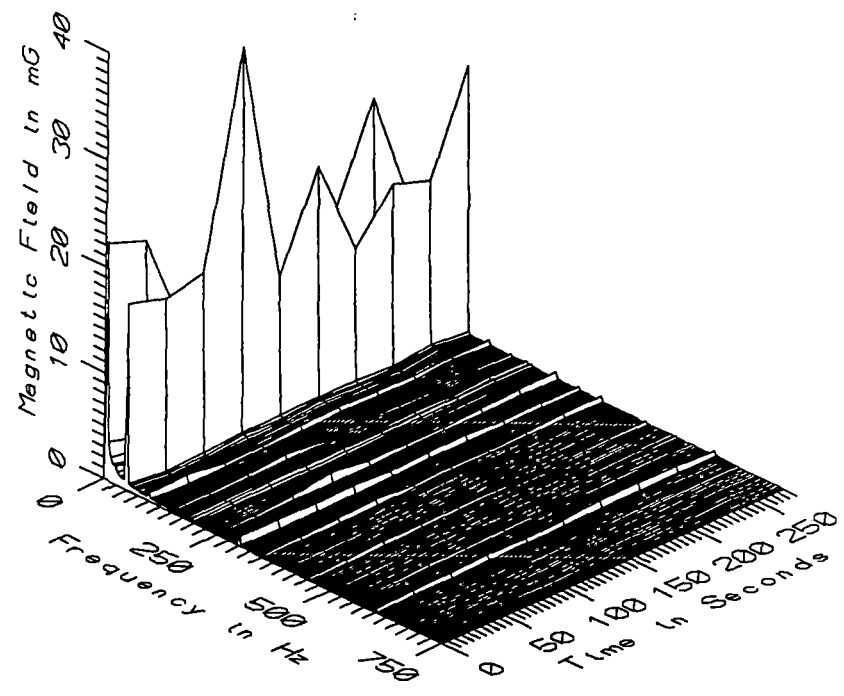

TGV003 - 10cm FROM CENTER OF DOOR AT FRONT OF COACH R1B

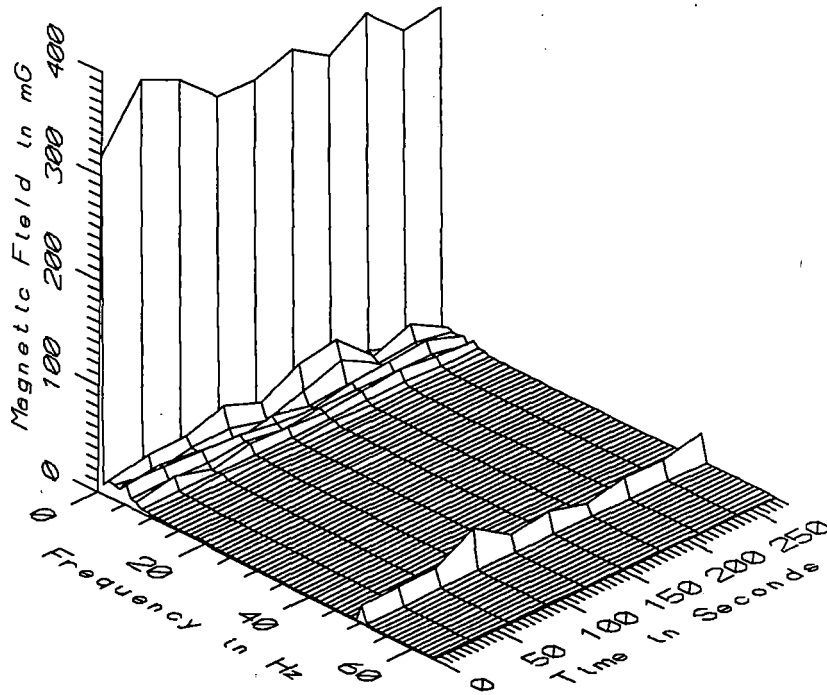

TGV003 - 60cm FROM CENTER OF DOOR AT FRONT OF COACH R1B

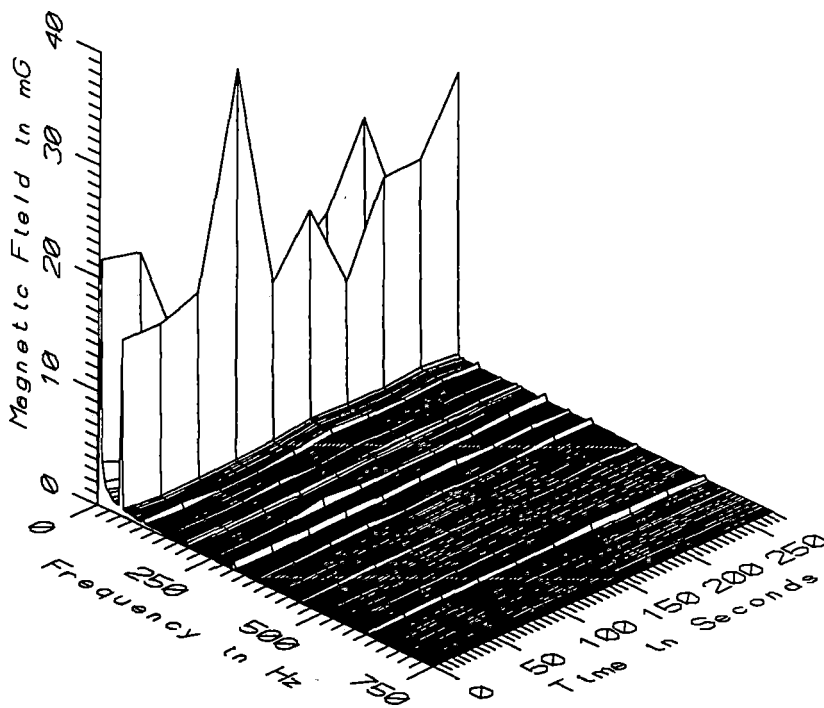

TGV003 - 60cm FROM CENTER OF DOOR AT FRONT OF COACH R1B

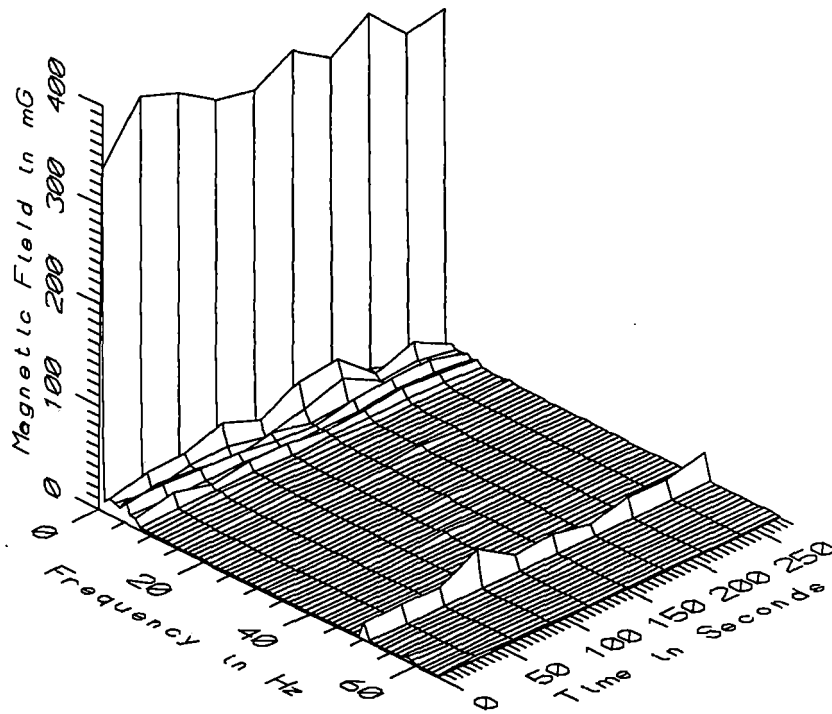

TGV003 - 110cm FROM CENTER OF DOOR AT FRONT OF COACH R1B

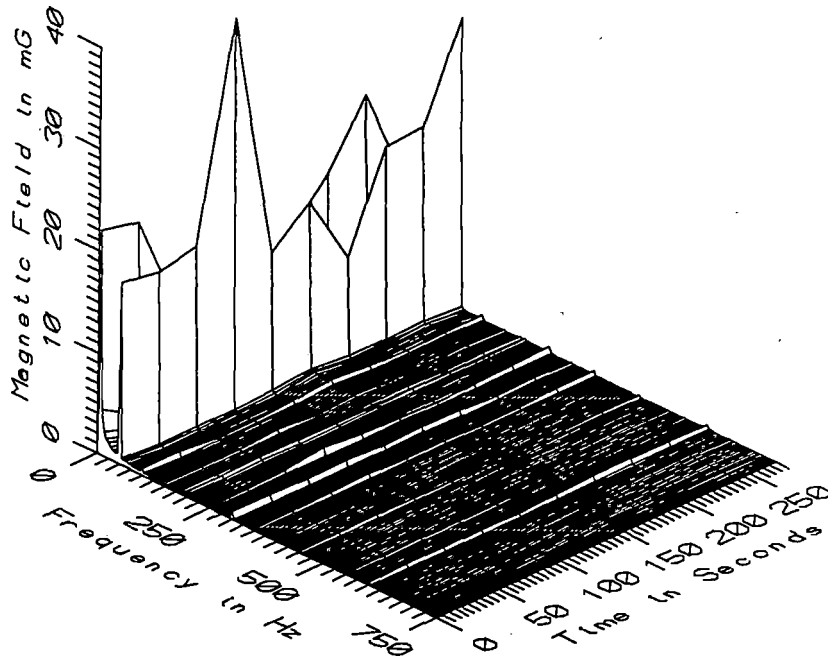

TGV003 - 110cm FROM CENTER OF DOOR AT FRONT OF COACH R1B



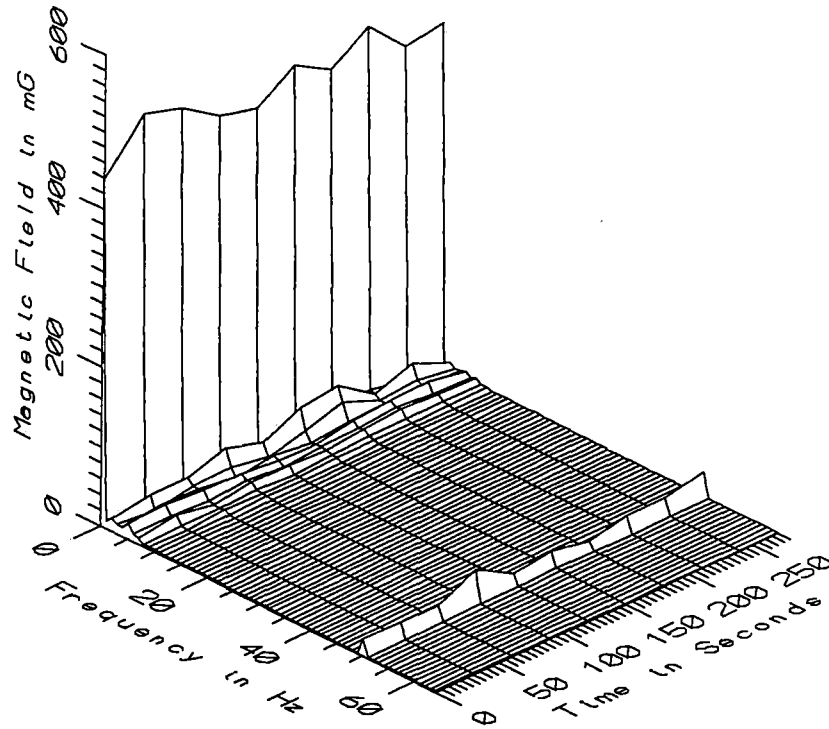

TGV003 - 160cm FROM CENTER OF DOOR AT FRONT OF COACH R1B

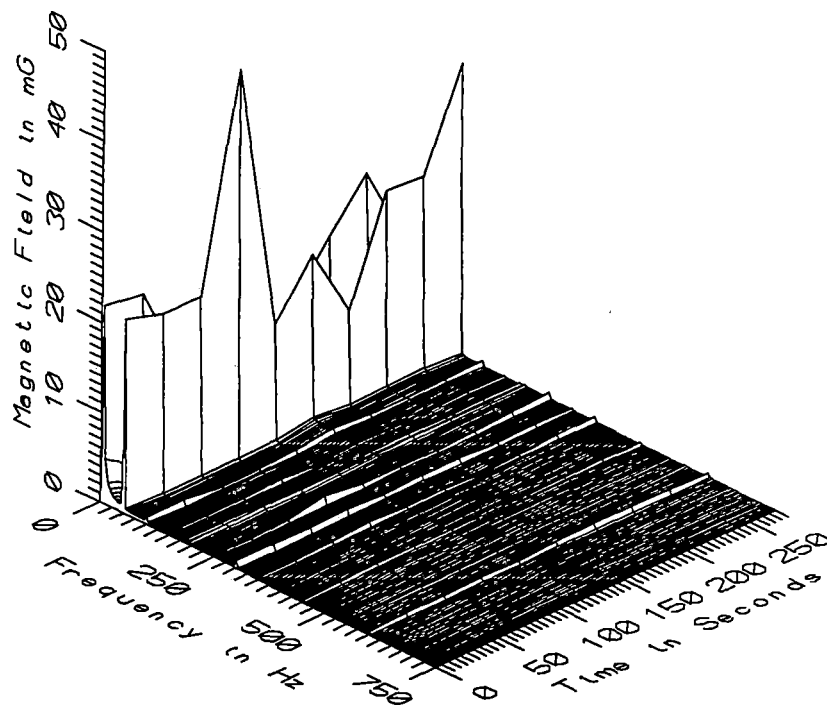

TGV003 - 160cm FROM CENTER OF DOOR AT FRONT OF COACH R1B

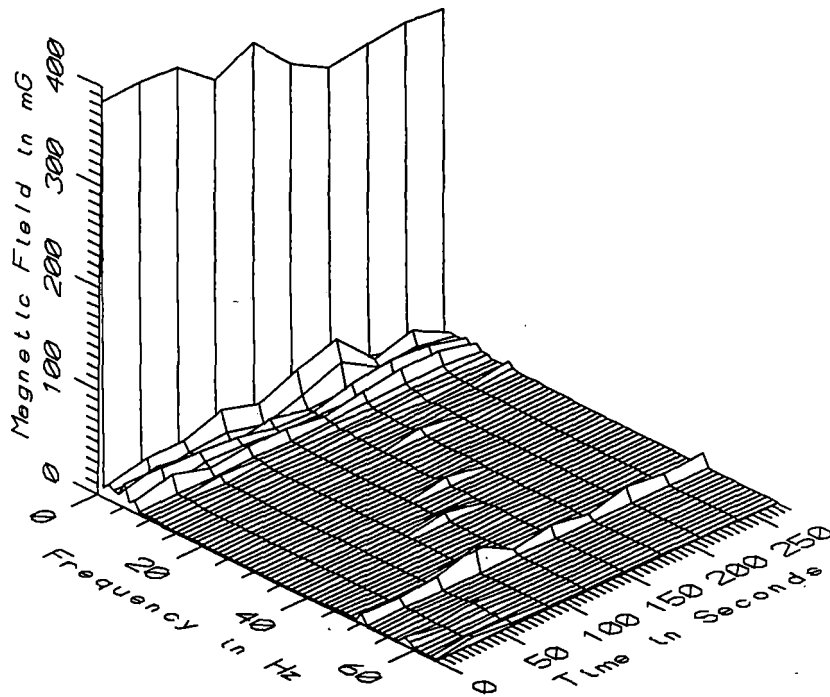

TGV003 - REFERENCE PROBE - ON CORNER SEAT AT FRONT OF COACH R1B

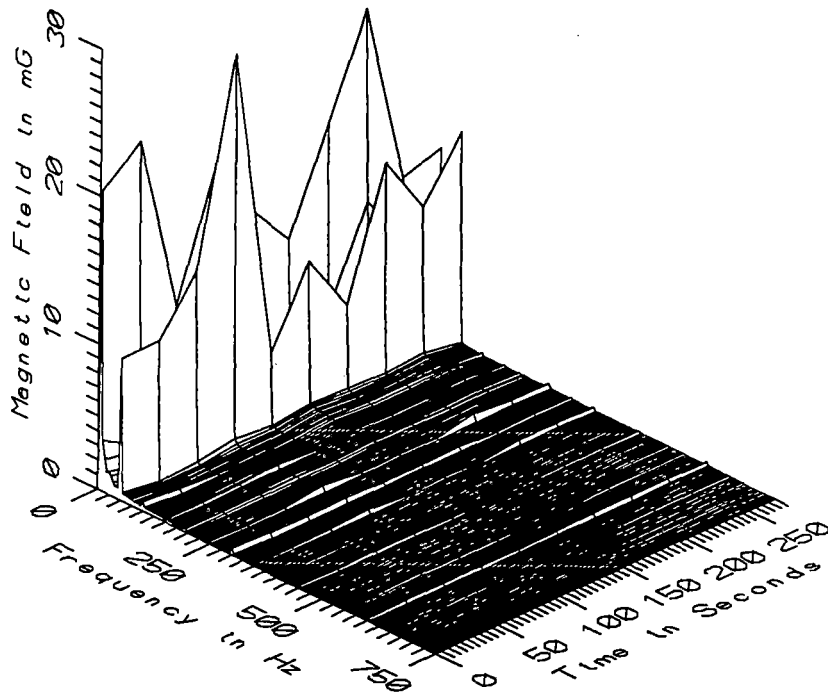

TGV003 - REFERENCE PROBE - ON CORNER SEAT AT FRONT OF COACH R1B

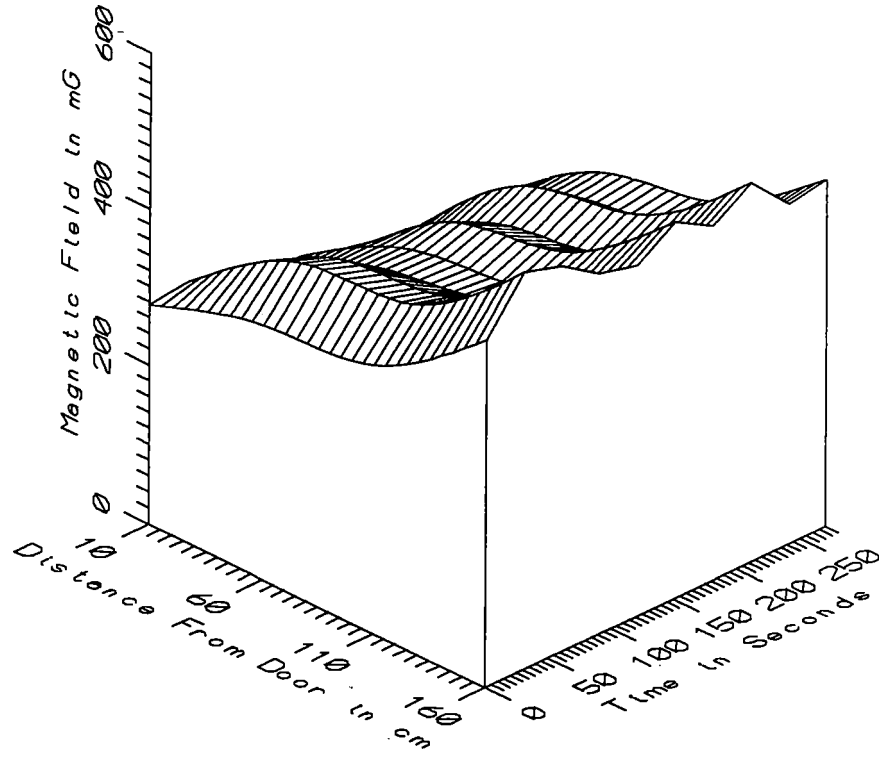

TGV003 - AXIAL PROFILE AT FRONT OF COACH R1B - STATIC

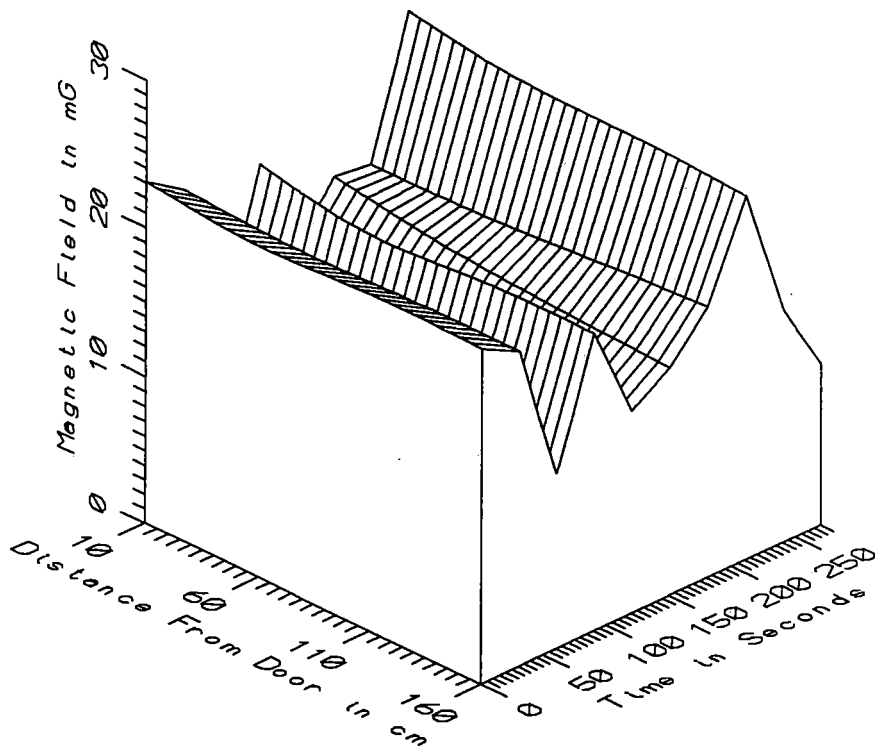

TGV003 - AXIAL PROFILE AT FRONT OF COACH R1B - LOW FREQ, 5-45Hz

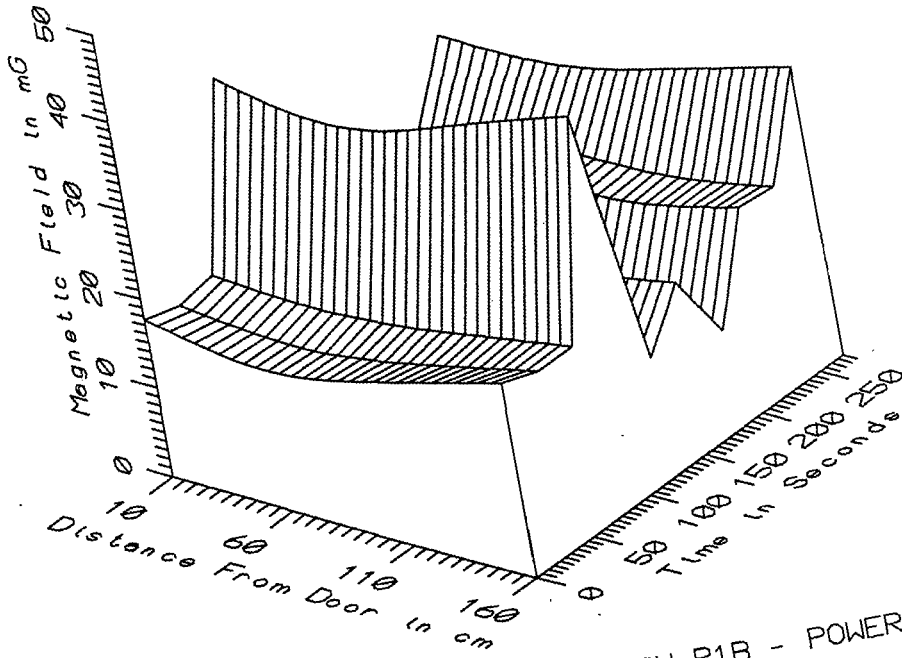

TGV003 - AXIAL PROFILE AT FRONT OF COACH R1B - POWER FREQ, 50-60Hz

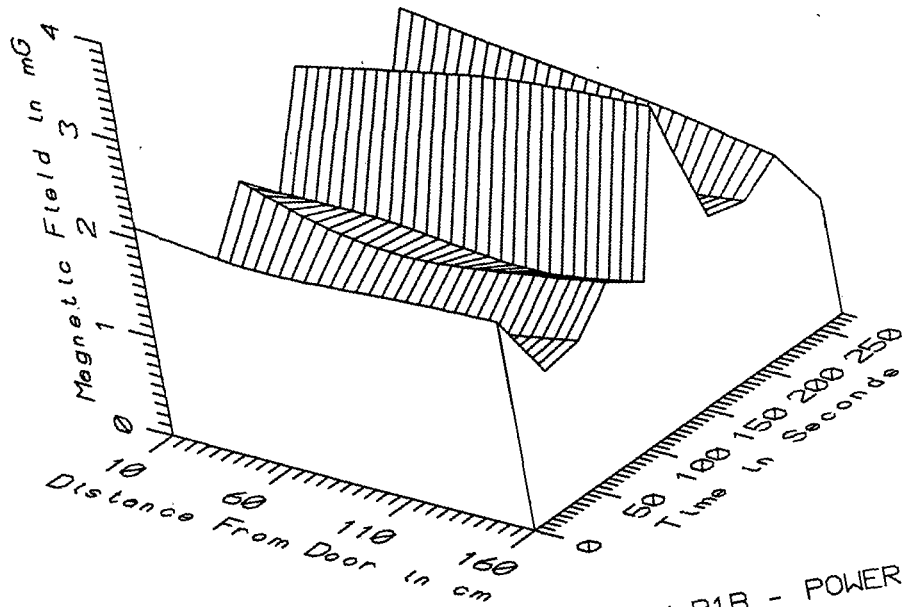

TGV003 - AXIAL PROFILE AT FRONT OF COACH R1B - POWER HARM, 65-300Hz

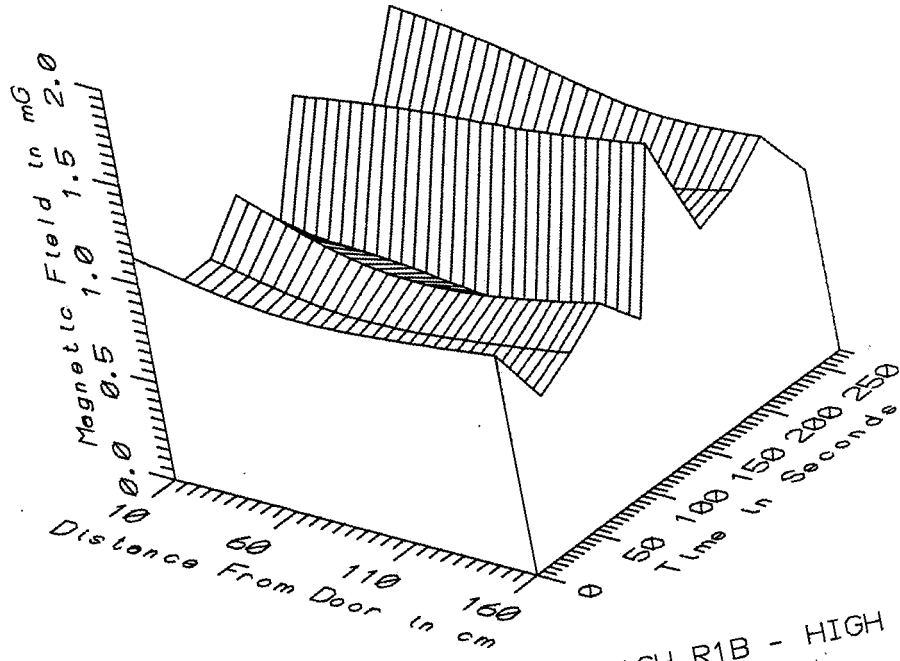

TGV003 - AXIAL PROFILE AT FRONT OF COACH R1B - HIGH FREQ, 305-2560Hz

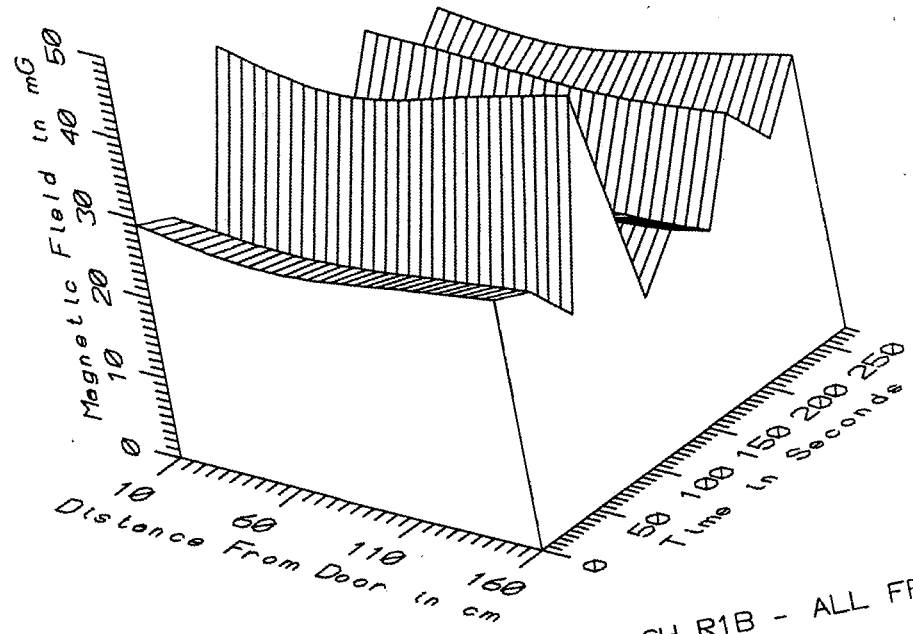

TGV003 - AXIAL PROFILE AT FRONT OF COACH R1B - ALL FREQ, 5-2560Hz

TGV003 - FIRST COACH, ALL SAMPLES IN AC SECTION					TOTAL OF 10 SAMPLES	
FREQUENCY BAND	DIST. FROM DOOR (cm)	MINIMUM MAGNETIC FIELD (mG)	MAXIMUM MAGNETIC FIELD (mG)	AVERAGE MAGNETIC FIELD (mG)	STANDARD DEVIATION (mG)	COEFFICIENT OF VARIATION (%)
STATIC	10	205.33	283.31	237.13	30.10	12.69
	60	306.74	376.23	332.05	21.94	6.61
	110	335.49	392.58	357.82	19.42	5.43
	160	432.74	501.97	460.86	24.13	5.24
5-45Hz LOW FREQ	10	11.44	26.22	18.01	4.74	26.31
	60	11.24	25.20	17.38	4.68	26.94
	110	11.12	25.06	17.56	4.74	26.99
	160	10.99	24.74	17.63	4.68	26.56
50-60Hz PWR FREQ	10	13.11	36.63	19.56	7.00	35.81
	60	11.38	34.92	19.07	6.70	35.10
	110	10.08	38.82	20.09	8.06	40.10
	160	11.01	43.45	22.53	9.28	41.18
65-300Hz PWR HARM	10	1.02	2.52	1.73	0.50	28.97
	60	0.91	2.80	1.66	0.55	33.44
	110	0.97	3.01	1.69	0.59	34.76
	160	1.17	3.12	1.80	0.54	29.72
305-2560Hz HIGH FREQ	10	0.78	1.42	1.06	0.21	19.60
	60	0.73	1.42	0.98	0.24	24.64
	110	0.70	1.47	0.96	0.24	24.93
	160	0.79	1.57	1.04	0.23	22.24
5-2560Hz ALL FREQ	10	19.63	42.08	27.13	6.62	24.40
	60	19.95	40.06	26.39	6.09	23.08
	110	19.71	43.76	27.36	7.12	26.04
	160	19.45	48.00	29.31	8.23	28.06

APPENDIX E

DATASET TGV004

TRANSVERSE PROFILE IN FIRST CLASS SALON AT FRONT OF COACH R1B

Measurement Setup Code:       Staff: 3       Reference: 4  
                                  Drawing: A-1

Vehicle Status:               Coach trip from Montparnasse  
                                  station in Paris to Tours station

Measurement Date:             September 8, 1992

Measurement Time:            Start:     08:28:04  
                                  End:       08:32:30

Number of Samples:            10

Programmed Sample Interval:   30 sec

Actual Sample Interval:       29.6 sec

Frequency Spectrum Parameters

<u>Probe Type:</u>	<u>Wideband</u>	<u>Static</u>
Maximum Frequency (Hz)	2560	64
Minimum Frequency (Hz)	5	0
Spectral Bandwidth (Hz)	5	1

Missing or Suspect Data:       None

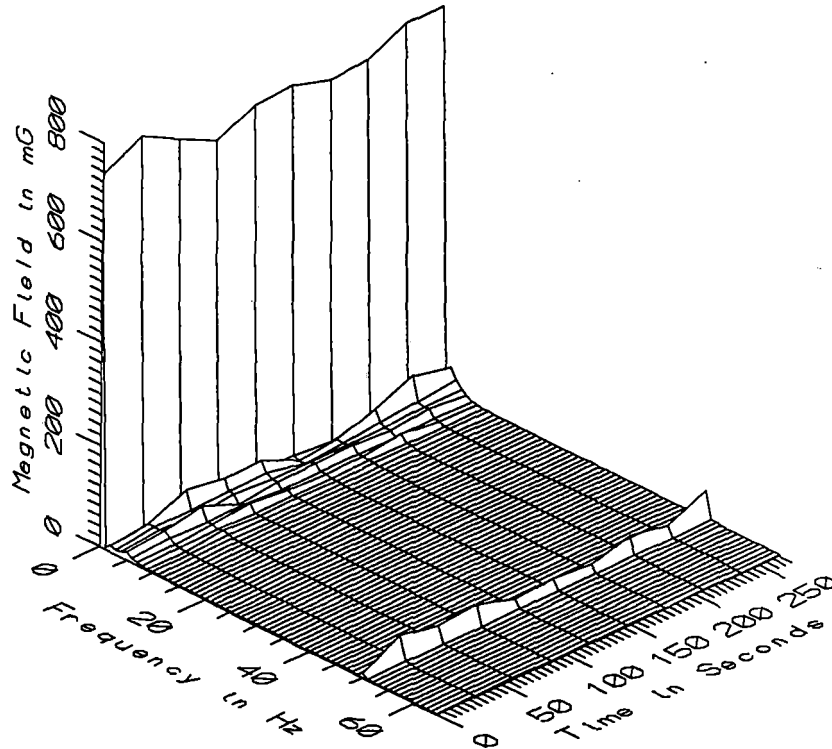

TGV004 - 10cm FROM WINDOW ABOVE SIDE SEAT AT FRONT OF COACH R1B

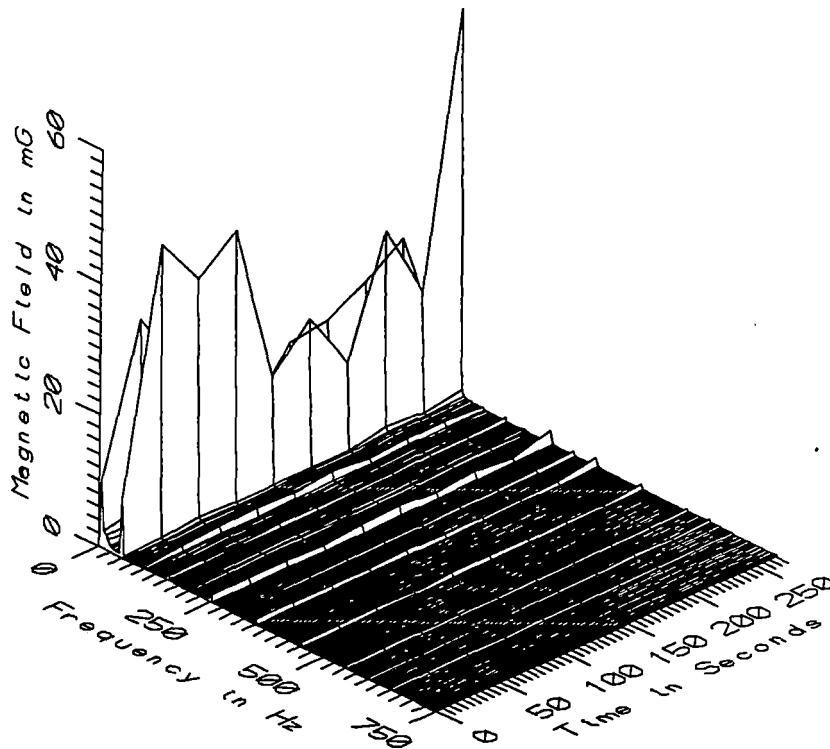

TGV004 - 10cm FROM WINDOW ABOVE SIDE SEAT AT FRONT OF COACH R1B



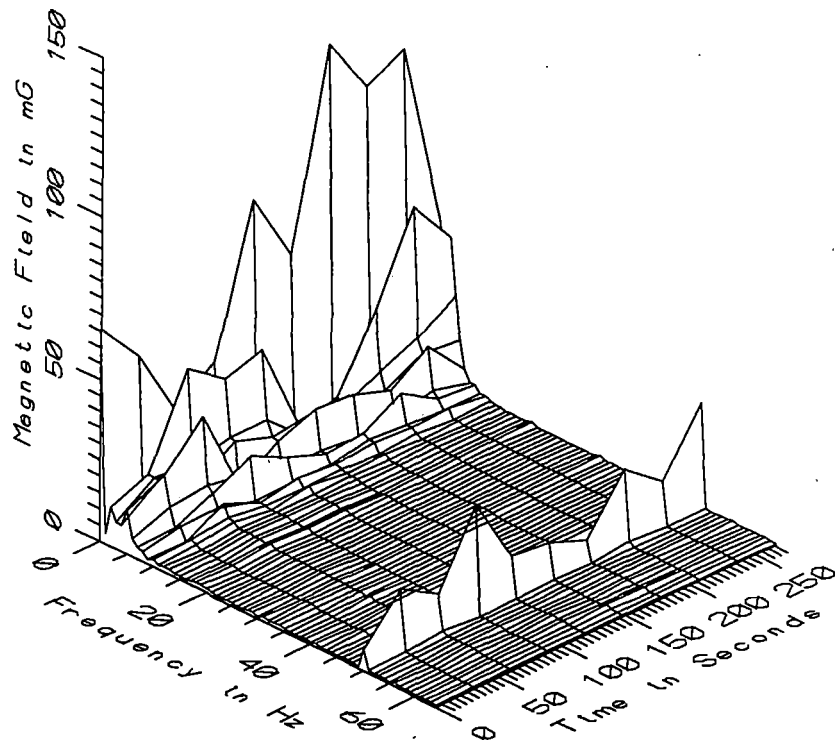

TGV004 - 60cm FROM WINDOW ABOVE SIDE SEAT AT FRONT OF COACH R1B

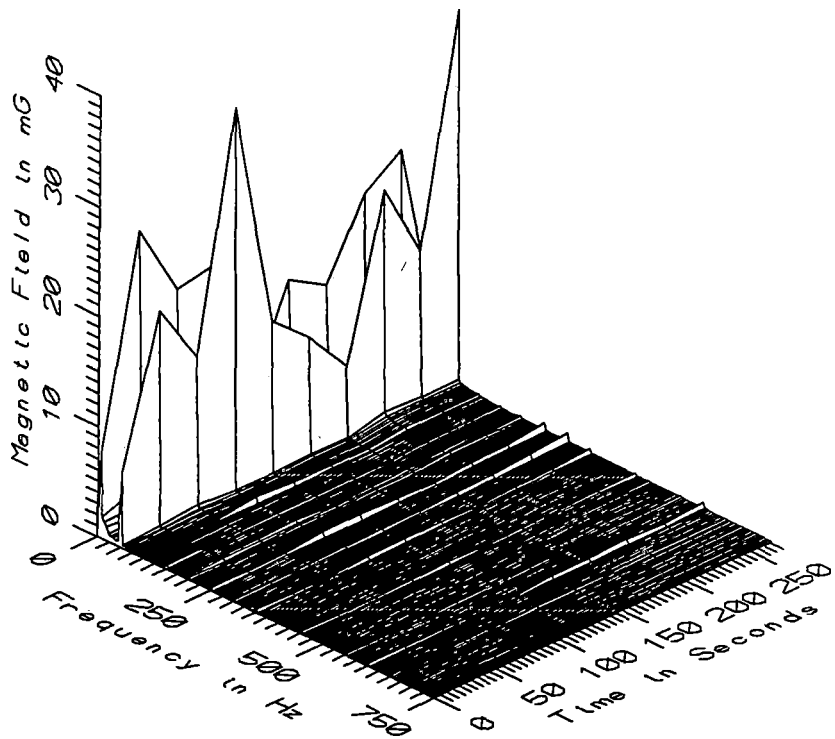

TGV004 - 60cm FROM WINDOW ABOVE SIDE SEAT AT FRONT OF COACH R1B

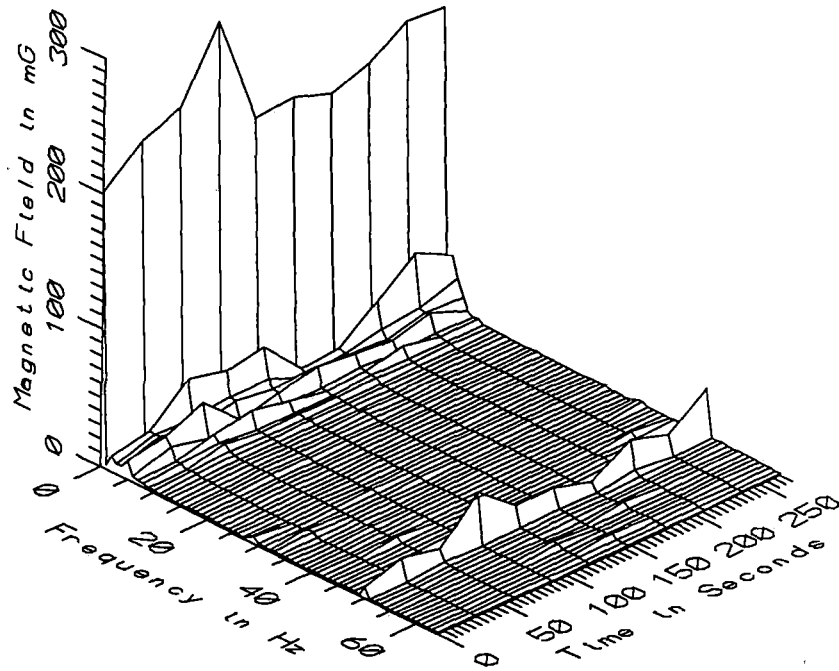

TGV004 - 110cm FROM WINDOW ABOVE SIDE SEAT AT FRONT OF COACH R1B

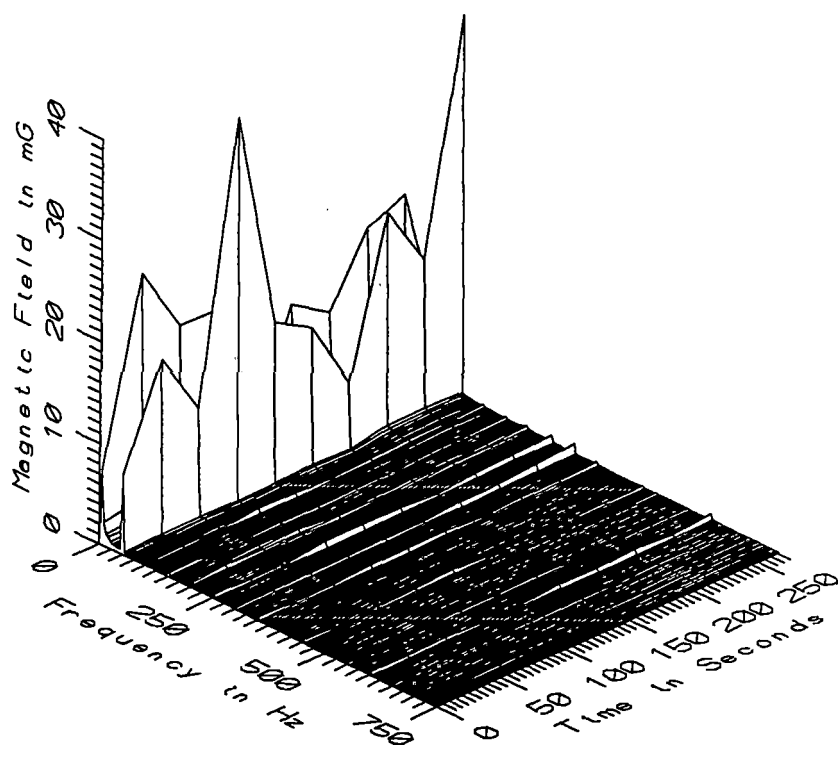

TGV004 - 110cm FROM WINDOW ABOVE SIDE SEAT AT FRONT OF COACH R1B

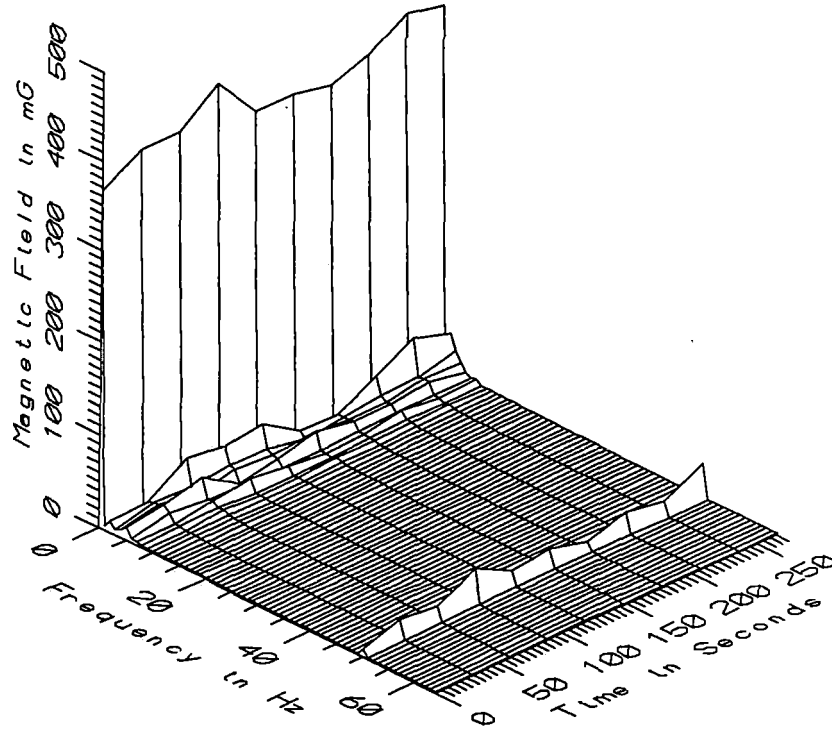

TGV004 - 160cm FROM WINDOW ABOVE SIDE SEAT AT FRONT OF COACH R1B

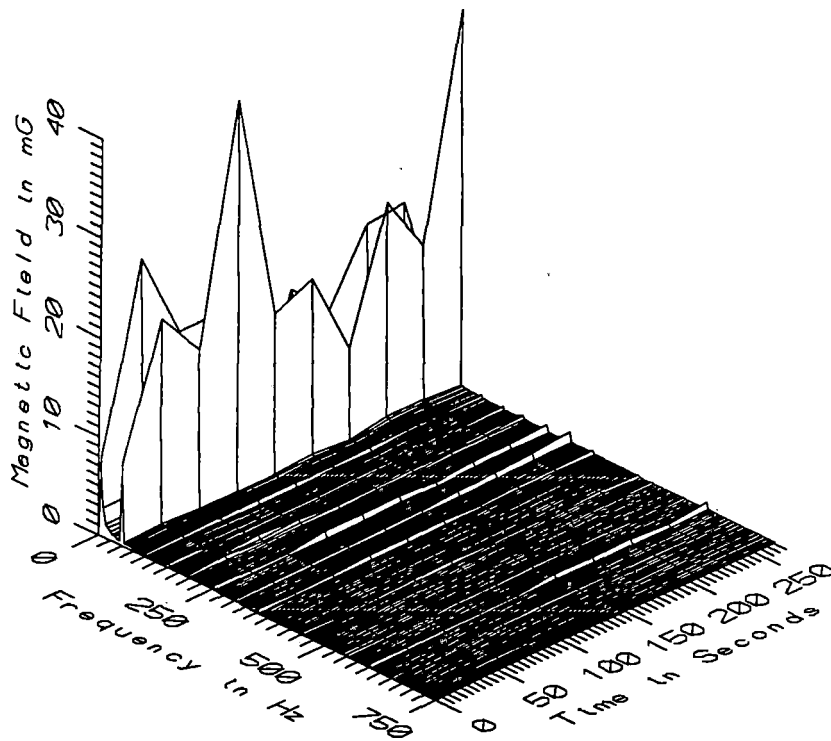

TGV004 - 160cm FROM WINDOW ABOVE SIDE SEAT AT FRONT OF COACH R1B

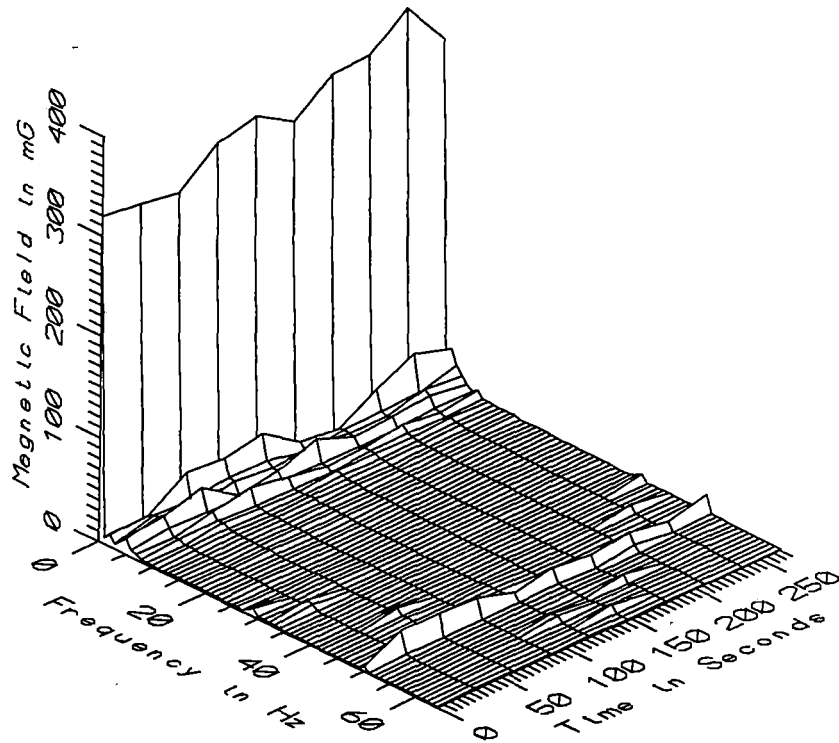

TGV004 - REFERENCE PROBE - ON CORNER SEAT AT FRONT OF COACH R1B

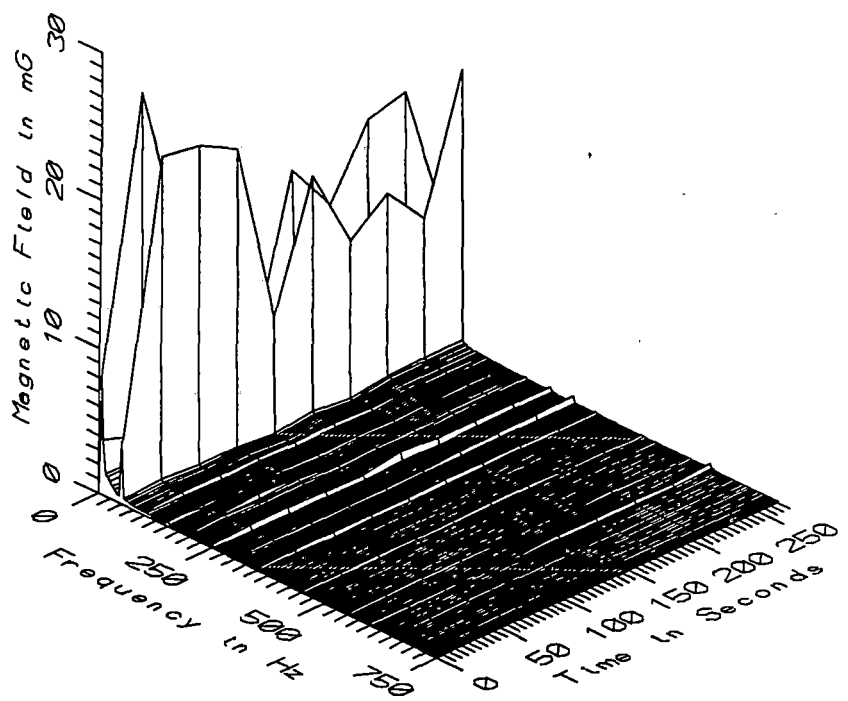

TGV004 - REFERENCE PROBE - ON CORNER SEAT AT FRONT OF COACH R1B

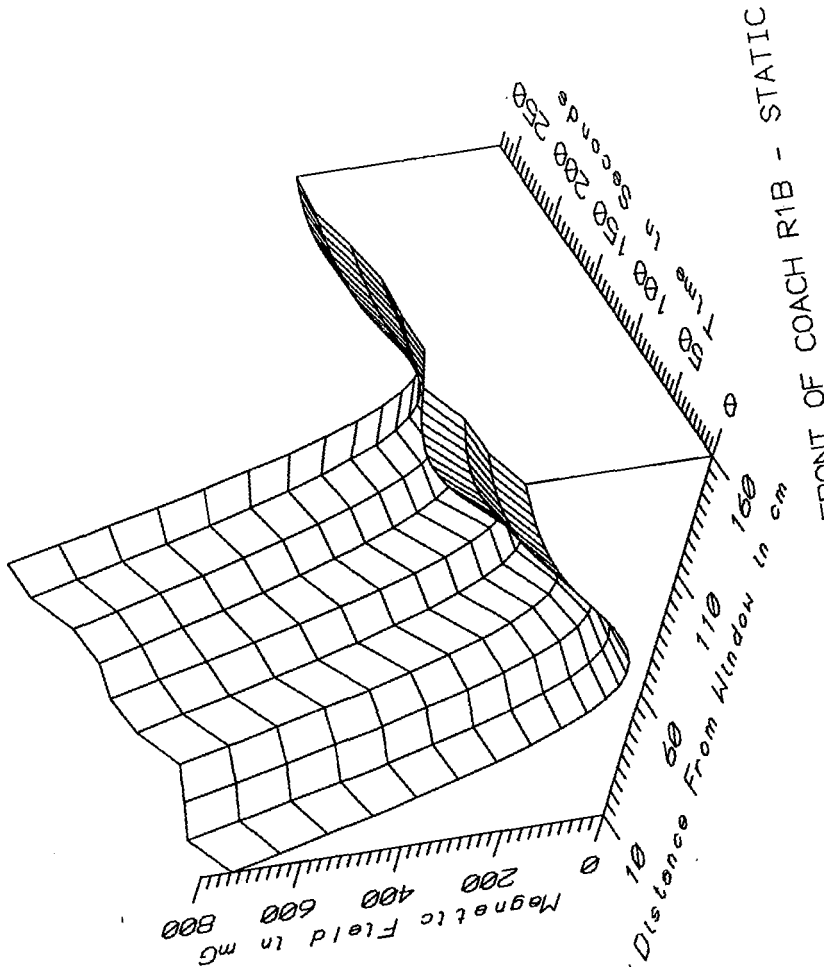

TGV004 - TRANSVERSE PROFILE AT FRONT OF COACH R1B - STATIC

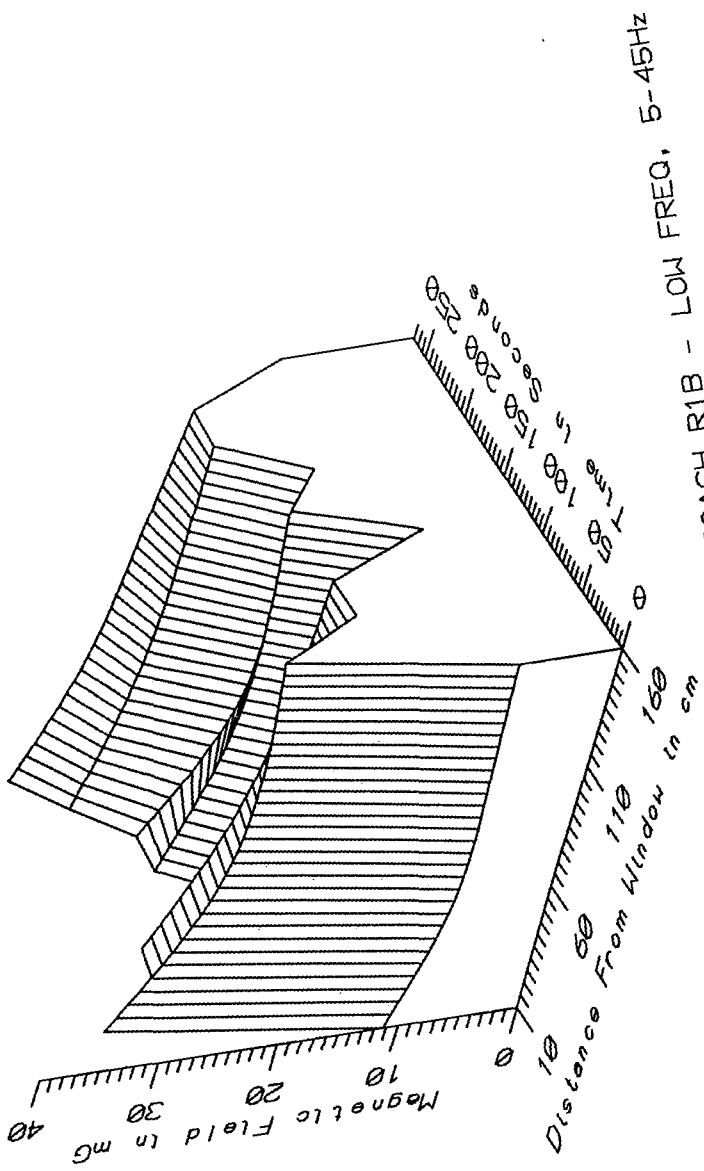

5-45Hz

LOW FREQ.

COACH R1B

FRONT OF

TRANSVERSE PROFILE

TGV004 -

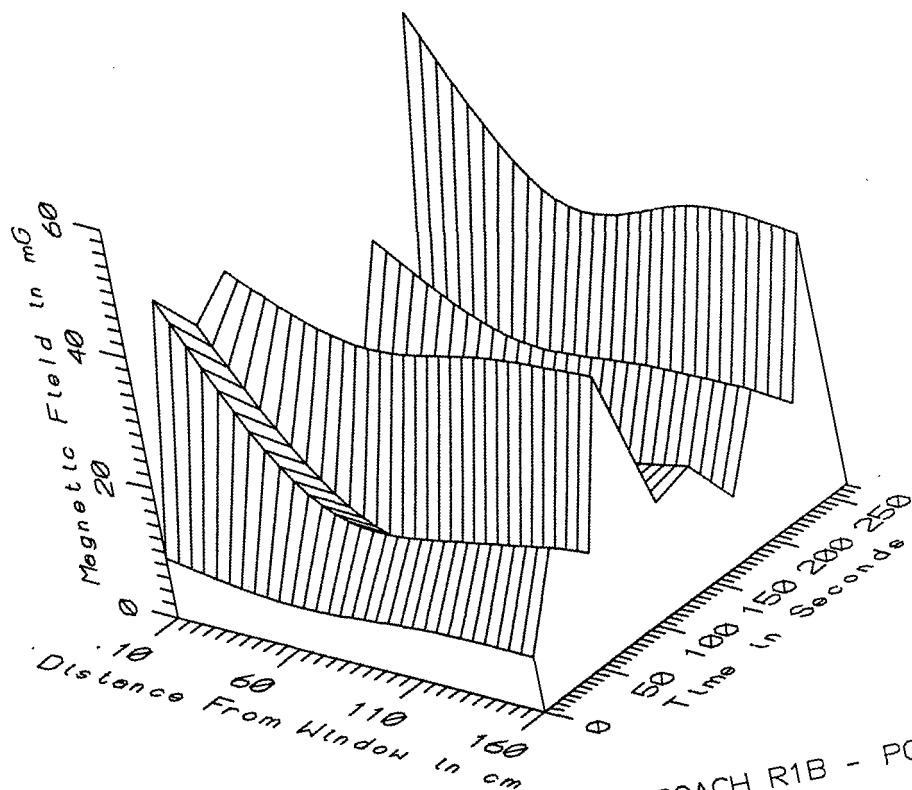

TGV004 - TRANSVERSE PROFILE AT FRONT OF COACH R1B - POWER FREQ, 50-60Hz

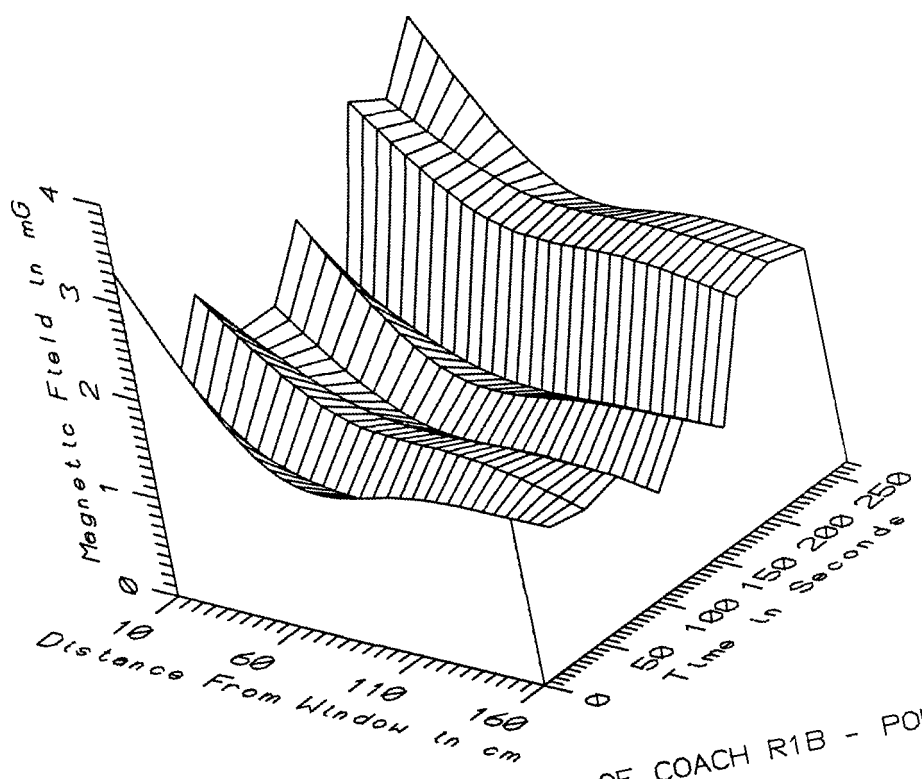

TGV004 - TRANSVERSE PROFILE AT FRONT OF COACH R1B - POWER HARM, 65-300Hz

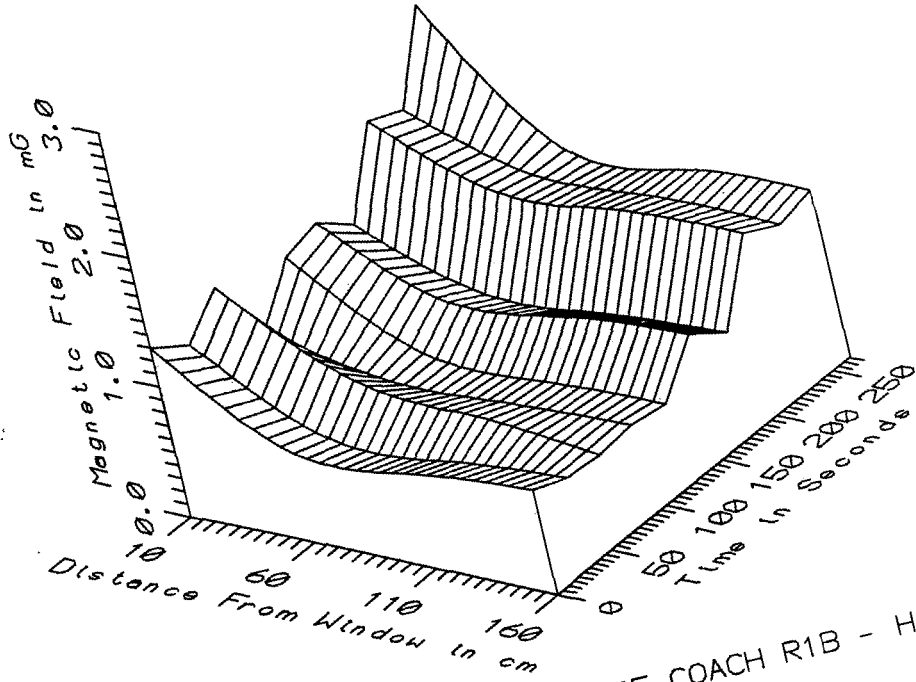

TGV004 - TRANSVERSE PROFILE AT FRONT OF COACH R1B - HIGH FREQ, 305-2560Hz

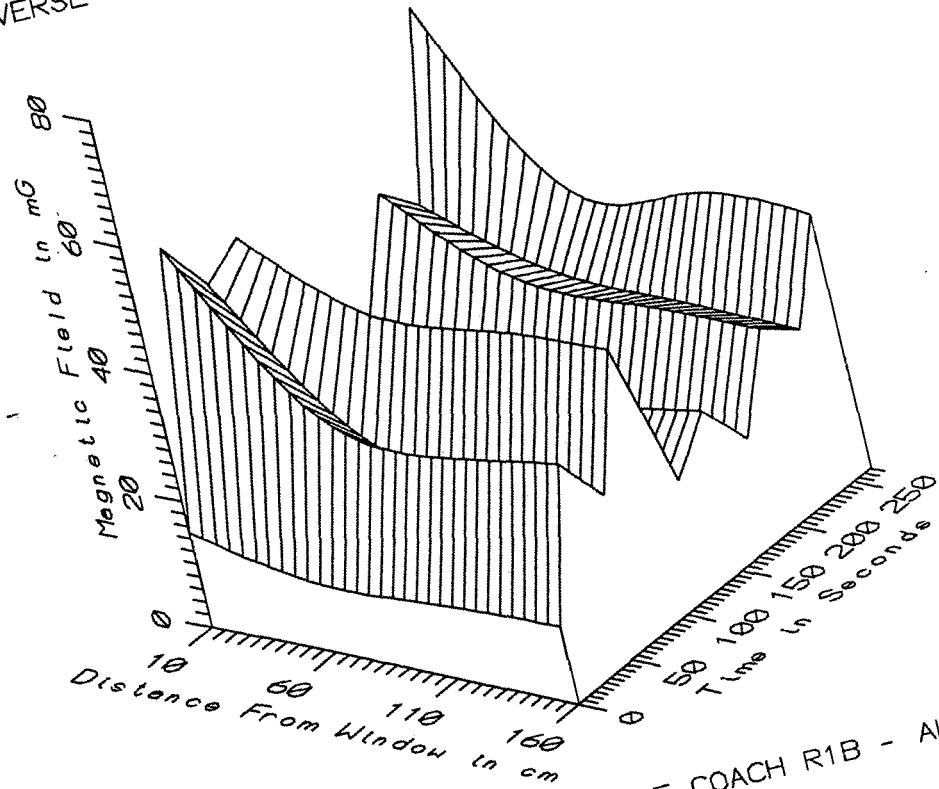

TGV004 - TRANSVERSE PROFILE AT FRONT OF COACH R1B - ALL FREQ, 5-2560Hz



TGV004 - FIRST COACH, ALL SAMPLES IN AC SECTION				TOTAL OF 10 SAMPLES		
FREQUENCY BAND	DIST. FROM WINDOW (cm)	MINIMUM MAGNETIC FIELD (mG)	MAXIMUM MAGNETIC FIELD (mG)	AVERAGE MAGNETIC FIELD (mG)	STANDARD DEVIATION (mG)	COEFFICIENT OF VARIATION (%)
STATIC	10	701.32	778.93	743.59	23.36	3.14
	60	28.82	121.31	71.27	31.41	44.08
	110	197.94	288.27	222.07	26.70	12.02
	160	366.80	430.60	391.99	19.25	4.91
5-45Hz LOW FREQ	10	10.32	32.57	21.13	7.23	34.22
	60	8.32	26.62	17.42	6.43	36.89
	110	8.31	25.33	16.61	5.85	35.21
	160	8.79	26.48	16.62	5.70	34.26
50-60Hz PWR FREQ	10	9.13	59.40	29.68	15.98	53.85
	60	6.69	35.11	17.76	10.13	57.03
	110	6.81	38.08	18.66	11.11	59.54
	160	8.29	39.72	20.67	10.63	51.45
65-300Hz PWR HARM	10	1.71	3.62	2.58	0.70	27.24
	60	1.10	2.41	1.65	0.51	30.91
	110	1.06	2.39	1.63	0.51	31.41
	160	0.97	2.31	1.61	0.47	29.37
305-2560Hz HIGH FREQ	10	0.81	2.17	1.33	0.38	28.24
	60	0.60	1.28	0.86	0.27	31.05
	110	0.62	1.34	0.89	0.28	31.24
	160	0.66	1.36	0.92	0.27	29.50
5-2560Hz ALL FREQ	10	14.93	60.44	37.58	14.95	39.79
	60	10.82	40.88	25.92	9.44	36.43
	110	11.63	42.64	26.12	9.87	37.78
	160	12.23	43.89	27.35	10.00	36.55

APPENDIX F

DATASET TGV005  
TEST TRAIN LOCOMOTIVE, AGAINST ENGINEER'S CHAIR

Measurement Setup Code: Staff: 5 Reference: 8  
Drawing: A-2

Vehicle Status: Locomotive trip from Tours station  
to Montparnasse station in Paris

Measurement Date: September 8, 1992

Measurement Time: Start: 09:15:28  
End: 09:28:30

Number of Samples: 75

Programmed Sample Interval: 10 sec

Actual Sample Interval: 10.6 sec

Frequency Spectrum Parameters

<u>Probe Type:</u>	<u>Wideband</u>	<u>Static</u>
Maximum Frequency (Hz)	2560	64
Minimum Frequency (Hz)	5	0
Spectral Bandwidth (Hz)	5	1

Missing or Suspect Data: None

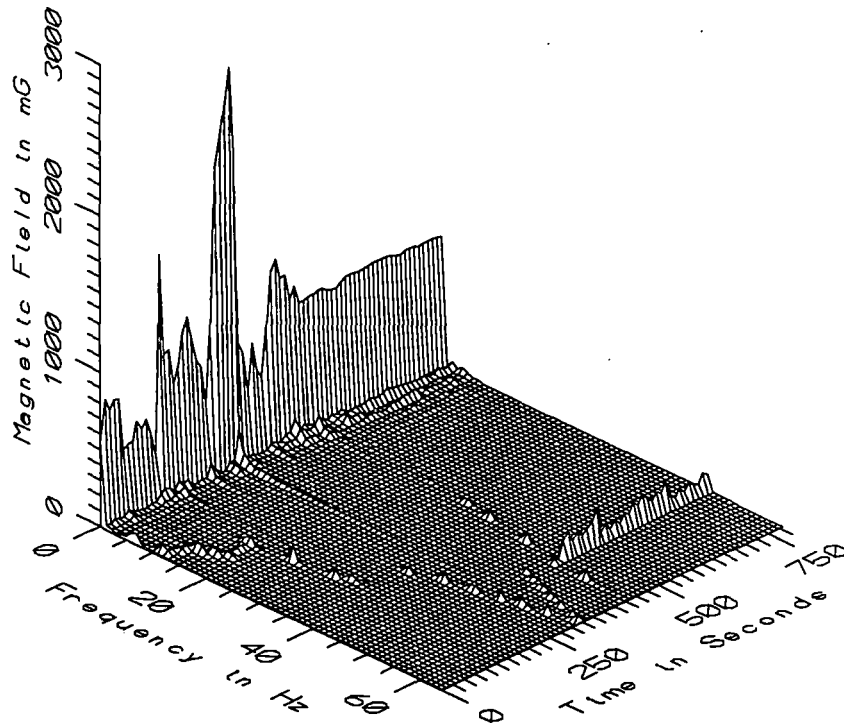

TGV005 - 10cm ABOVE FLOOR AGAINST ENGINEER'S CHAIR, PULL LOCOMOTIVE

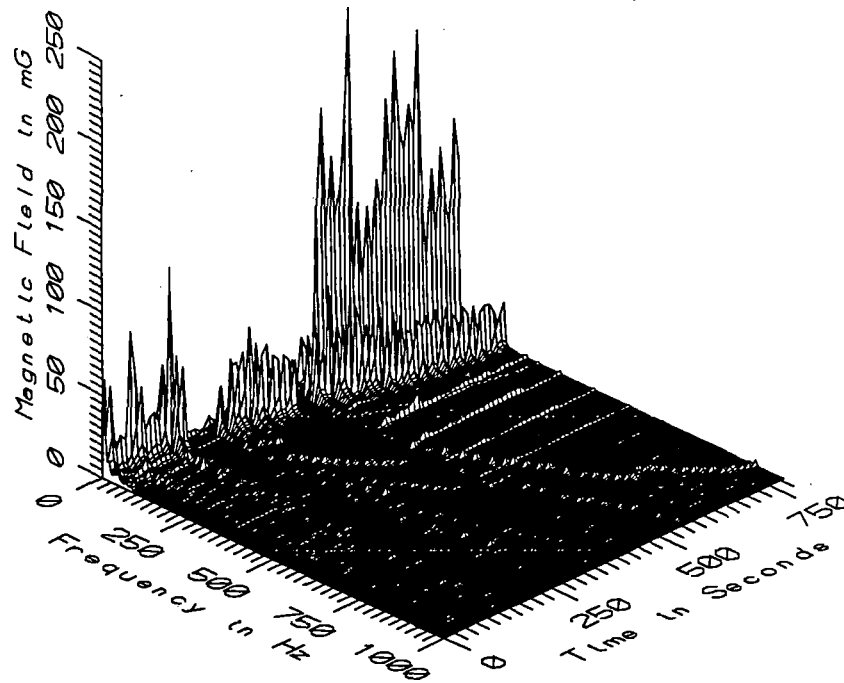

TGV005 - 10cm ABOVE FLOOR AGAINST ENGINEER'S CHAIR, PULL LOCOMOTIVE

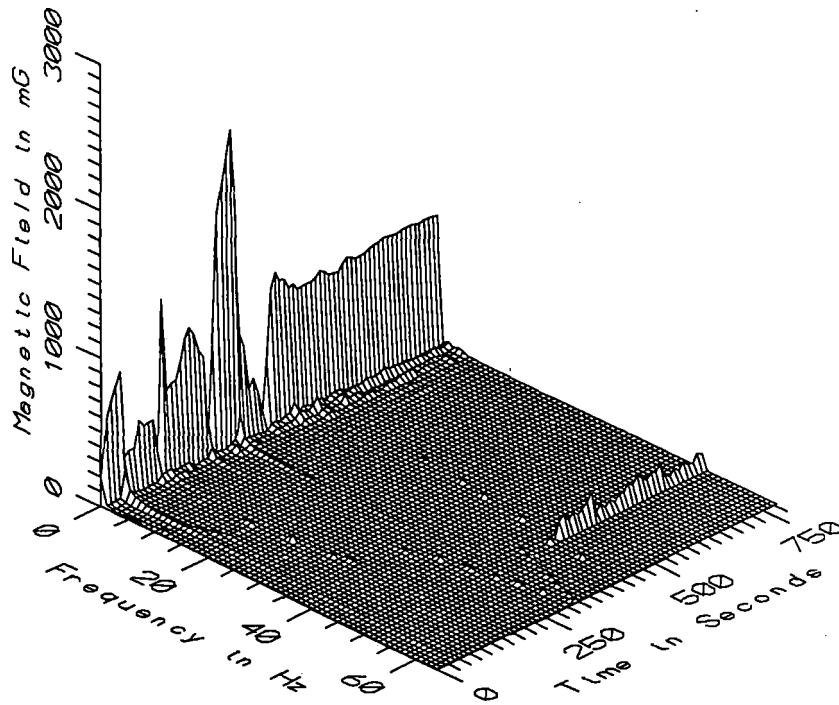

TGV005 - 60cm ABOVE FLOOR AGAINST ENGINEER'S CHAIR, PULL LOCOMOTIVE

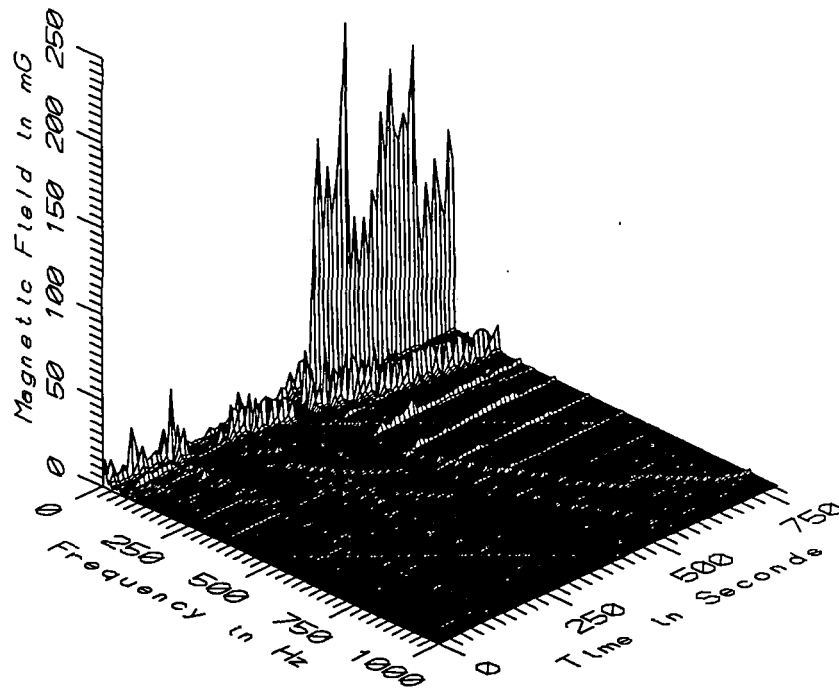

TGV005 - 60cm ABOVE FLOOR AGAINST ENGINEER'S CHAIR, PULL LOCOMOTIVE

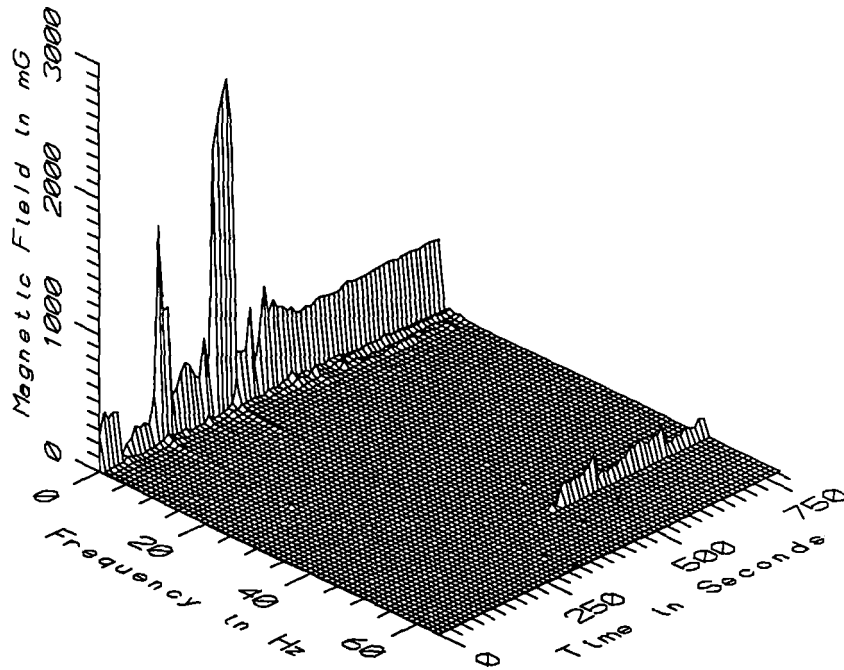

TGV005 - 110cm ABOVE FLOOR AGAINST ENGINEER'S CHAIR, PULL LOCOMOTIVE

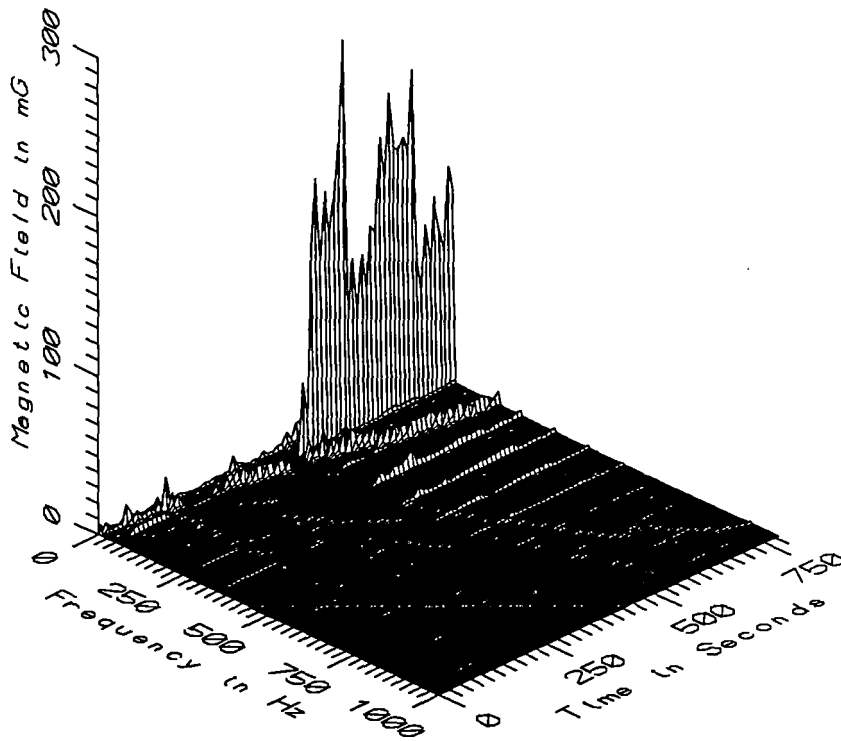

TGV005 - 110cm ABOVE FLOOR AGAINST ENGINEER'S CHAIR, PULL LOCOMOTIVE

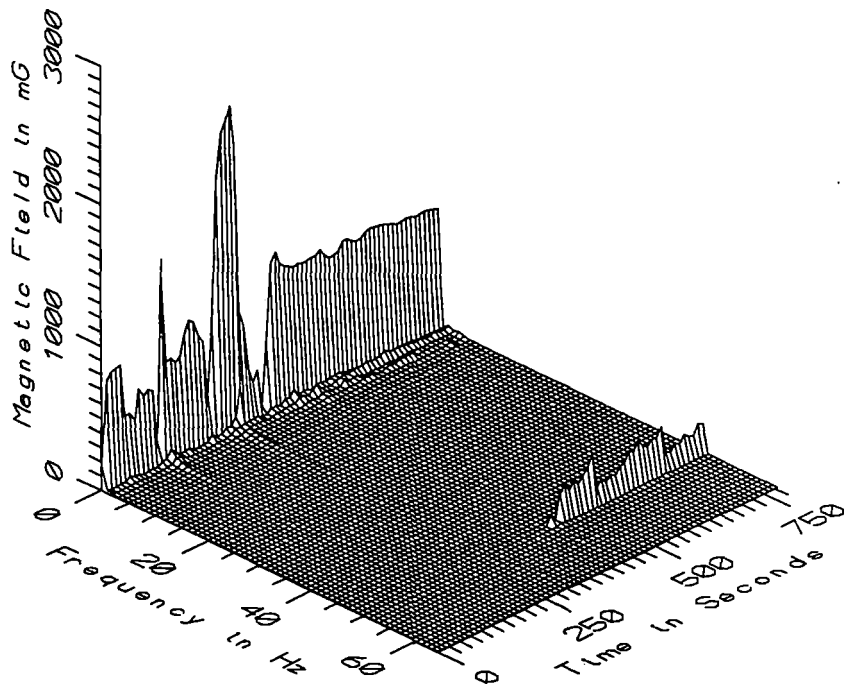

TGV005 - 160cm ABOVE FLOOR AGAINST ENGINEER'S CHAIR, PULL LOCOMOTIVE

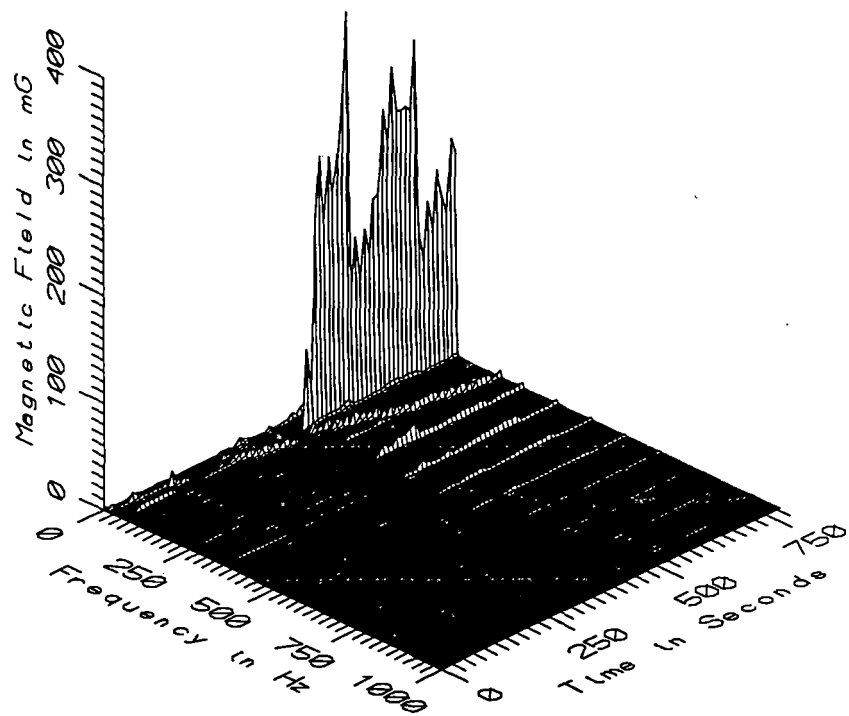

TGV005 - 160cm ABOVE FLOOR AGAINST ENGINEER'S CHAIR, PULL LOCOMOTIVE

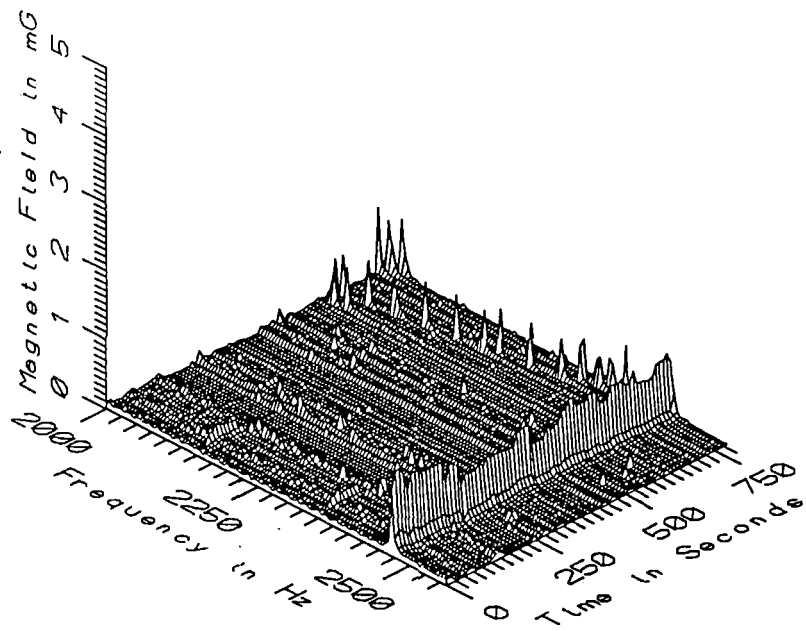

TGV005 - 10cm ABOVE FLOOR AGAINST ENGINEER'S CHAIR, PULL LOCOMOTIVE

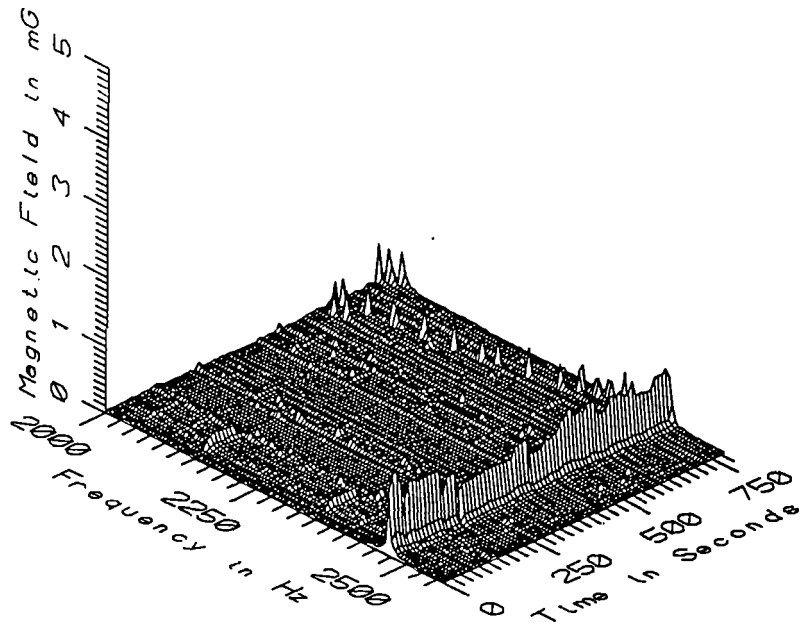

TGV005 - 60cm ABOVE FLOOR AGAINST ENGINEER'S CHAIR, PULL LOCOMOTIVE

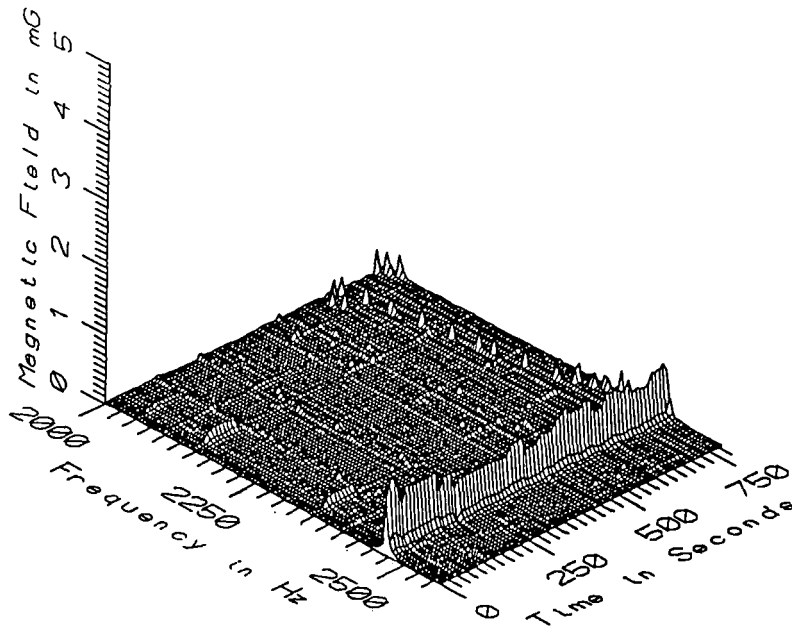

TGV005 - 110cm ABOVE FLOOR AGAINST ENGINEER'S CHAIR, PULL LOCOMOTIVE

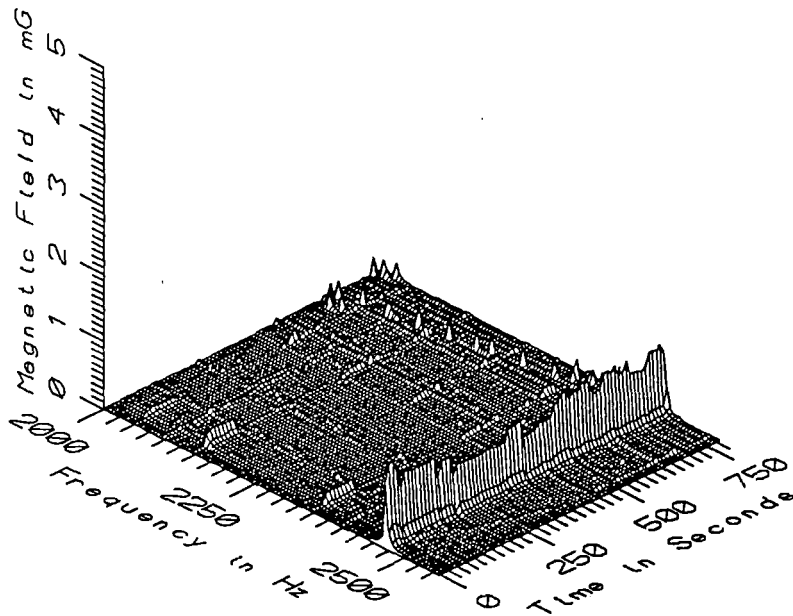

TGV005 - 160cm ABOVE FLOOR AGAINST ENGINEER'S CHAIR, PULL LOCOMOTIVE



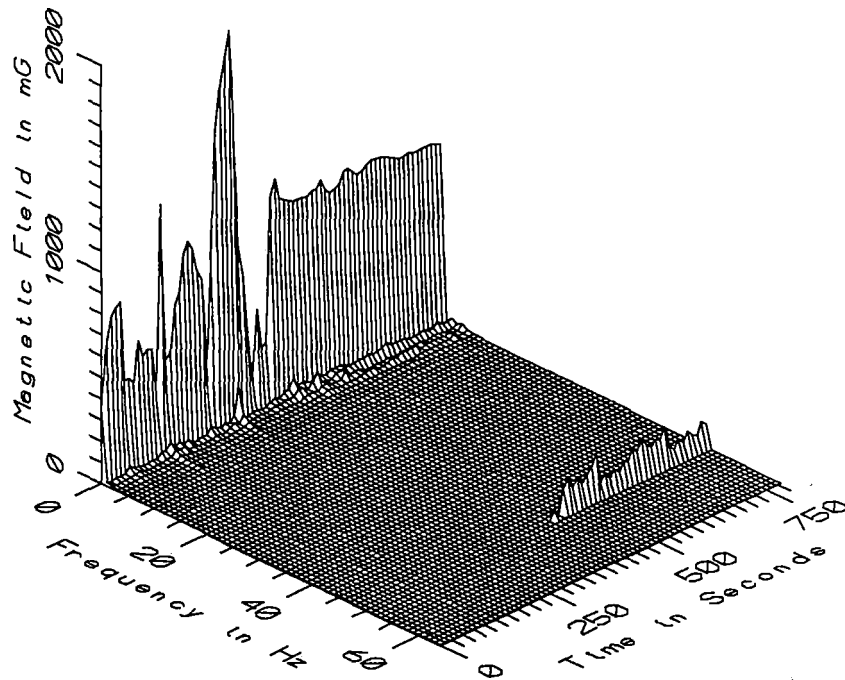

TGV005 - REF. PROBE - ASSISTANT ENGINEER'S CONSOLE, PULL LOCOMOTIVE

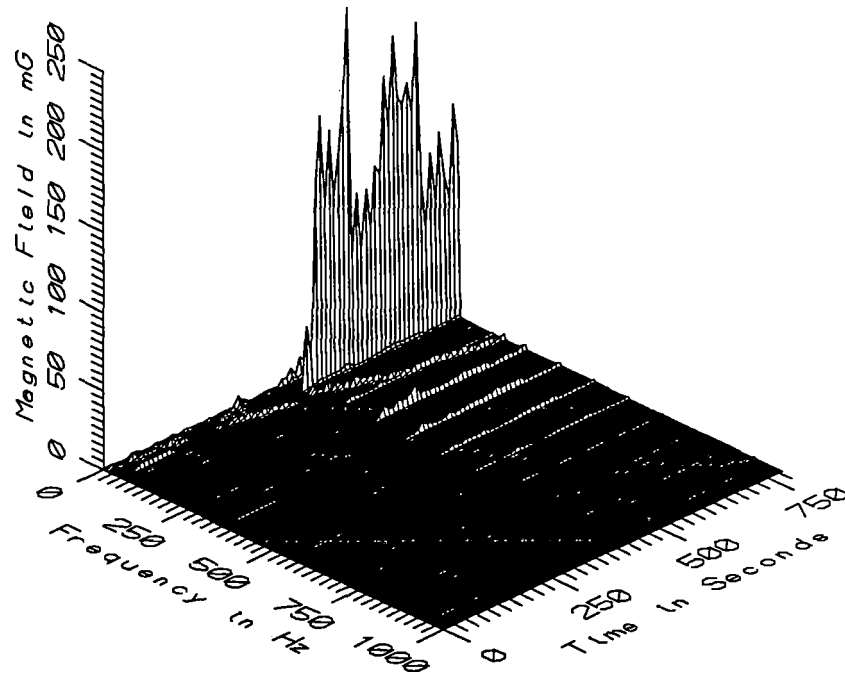

TGV005 - REF. PROBE - ASSISTANT ENGINEER'S CONSOLE, PULL LOCOMOTIVE

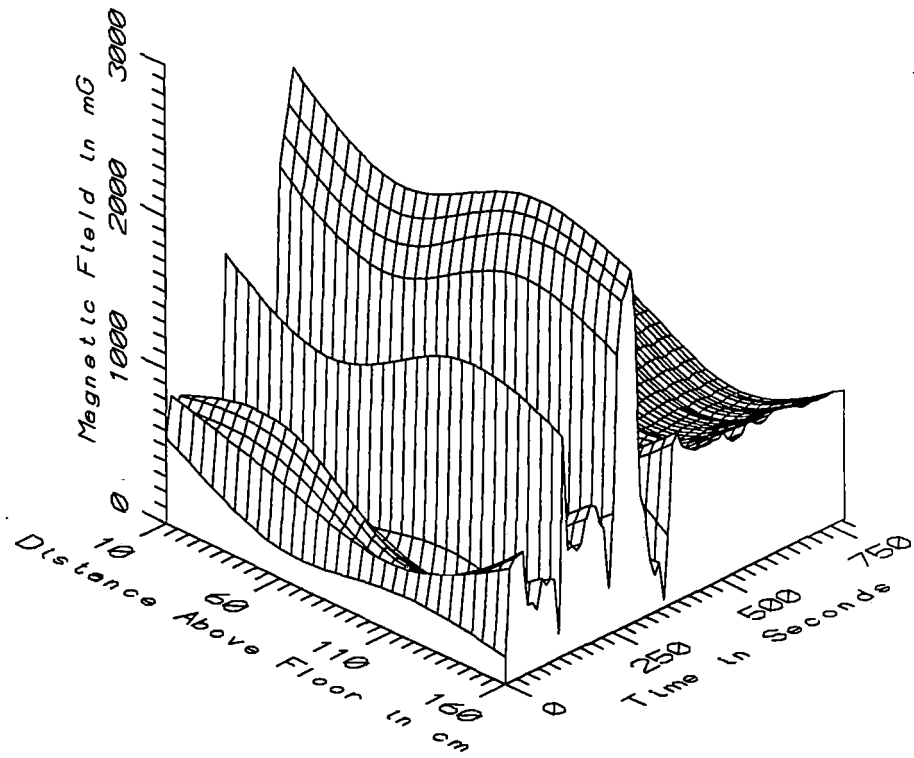

TGV005 - AGAINST ENGINEER'S CHAIR, PULL LOCOMOTIVE - STATIC

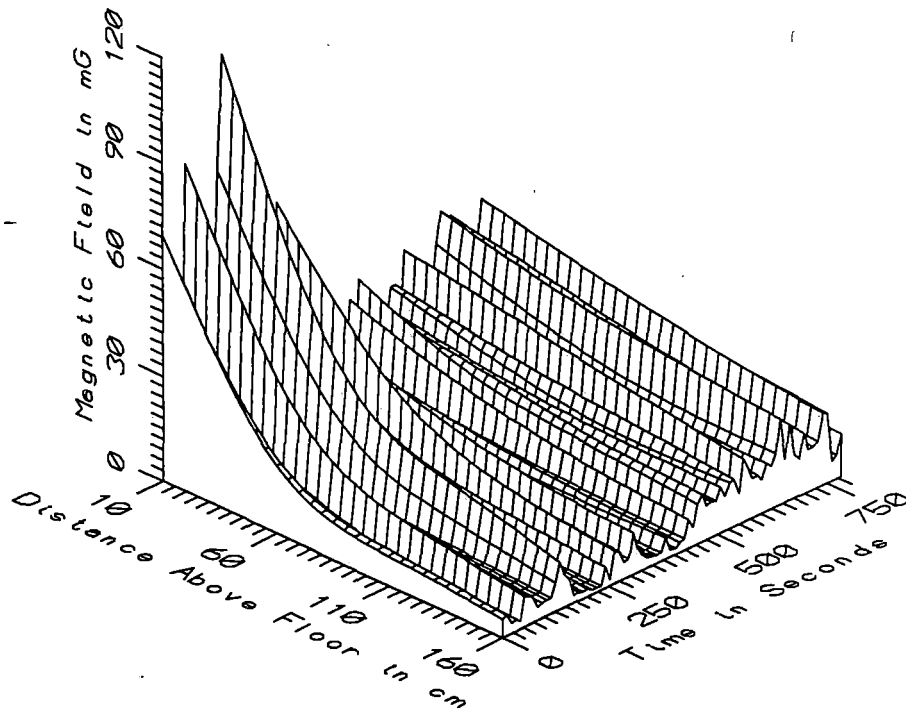

TGV005 - AGAINST ENGINEER'S CHAIR, PULL LOCOMOTIVE - LOW FREQ, 5-45Hz

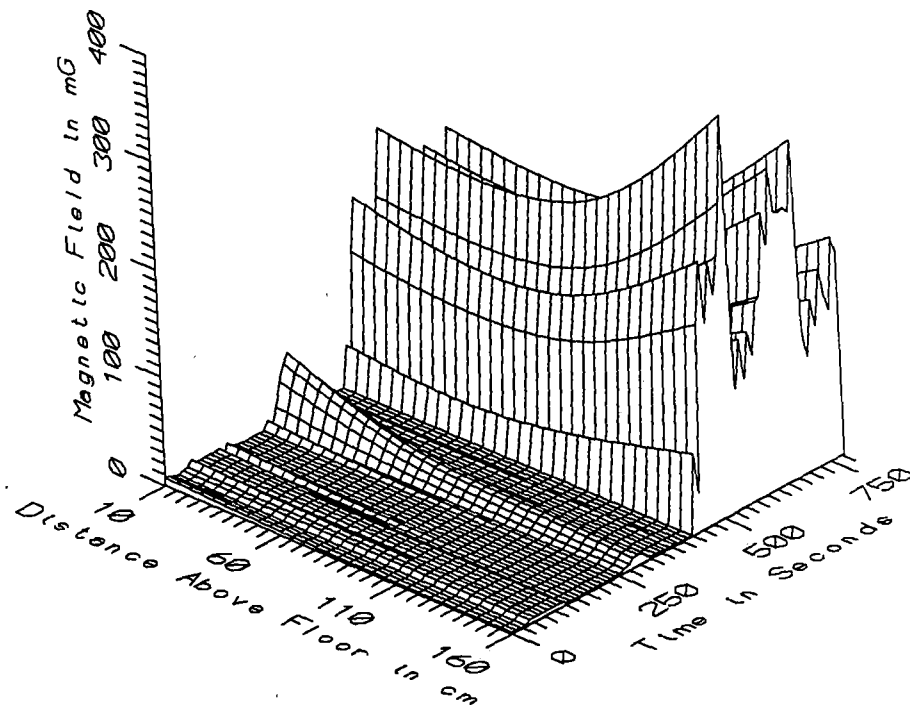

TGV005 - AGAINST ENGINEER'S CHAIR, PULL LOCOMOTIVE - POWER FREQ, 50-60Hz

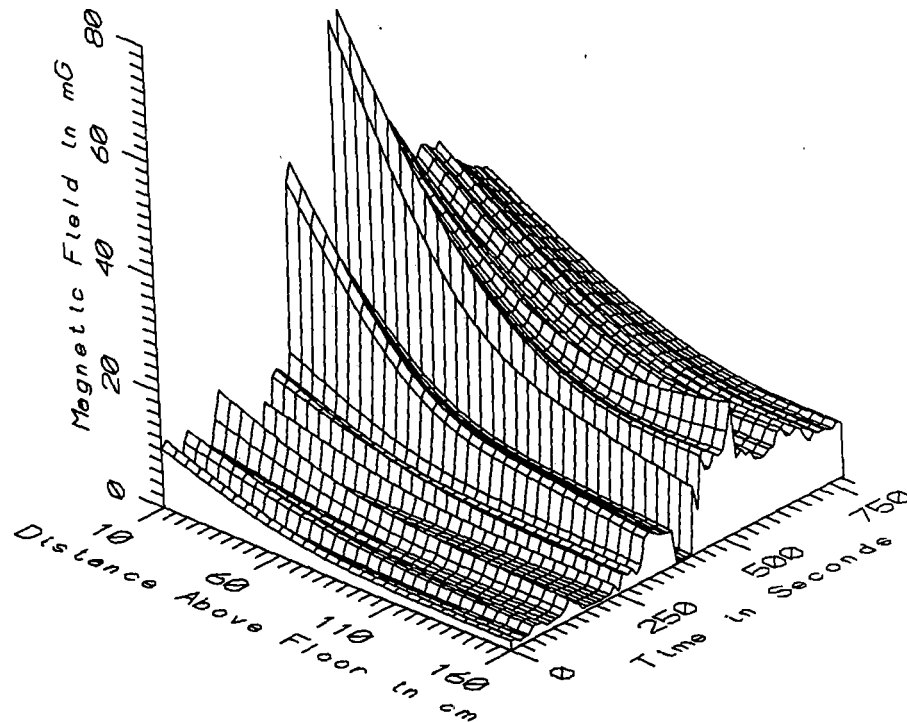

TGV005 - AGAINST ENGINEER'S CHAIR, PULL LOCOMOTIVE - POWER HARM, 65-300Hz

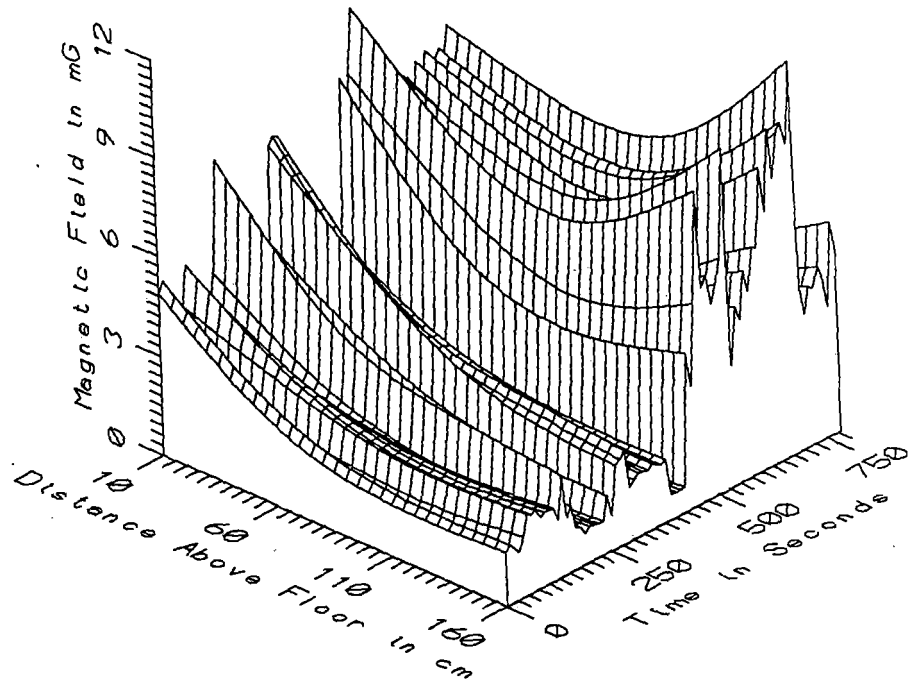

TGV005 - AGAINST ENGINEER'S CHAIR, PULL LOCOMOTIVE - HIGH FREQ, 305-2560Hz

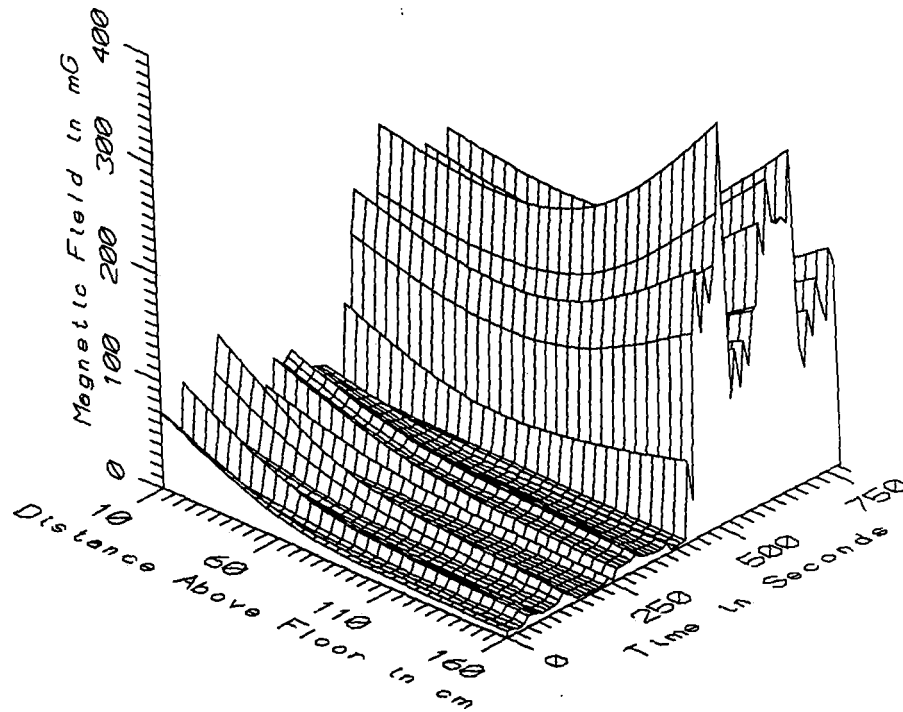

TGV005 - AGAINST ENGINEER'S CHAIR, PULL LOCOMOTIVE - ALL FREQ, 5-2560Hz

TGV005 - ALL SAMPLES		TOTAL OF 75 SAMPLES				
FREQUENCY BAND	HEIGHT ABOVE FLOOR (cm)	MINIMUM MAGNETIC FIELD (mG)	MAXIMUM MAGNETIC FIELD (mG)	AVERAGE MAGNETIC FIELD (mG)	STANDARD DEVIATION (mG)	COEFFICIENT OF VARIATION (%)
STATIC	10	307.50	2579.82	888.50	407.52	45.87
	60	115.92	2130.40	799.32	366.16	45.81
	110	37.21	2443.37	585.29	482.26	82.40
	160	48.34	2277.68	841.84	405.08	48.12
5-45Hz LOW FREQ	10	3.31	112.47	26.83	21.45	79.95
	60	1.97	41.95	14.56	8.46	58.11
	110	1.38	27.55	10.17	6.25	61.49
	160	1.17	24.61	8.52	5.47	64.17
50-60Hz PWR FREQ	10	0.38	220.66	54.56	59.29	108.67
	60	0.30	210.75	50.37	58.44	116.02
	110	0.29	247.45	59.36	70.41	118.63
	160	0.28	366.56	88.87	106.98	120.38
65-300Hz PWR HARM	10	0.57	68.33	25.33	19.39	76.53
	60	0.39	33.85	13.31	10.21	76.72
	110	0.37	19.82	7.85	6.00	76.43
	160	0.27	22.67	6.93	5.60	80.86
305-2560Hz HIGH FREQ	10	0.70	10.51	5.27	2.51	47.55
	60	0.62	7.54	3.63	1.89	51.91
	110	0.58	8.07	3.14	1.94	61.89
	160	0.74	11.85	3.94	2.91	73.92
5-2560Hz ALL FREQ	10	3.75	227.36	76.82	52.93	68.89
	60	2.36	213.38	58.95	55.25	93.72
	110	1.85	248.67	63.54	68.50	107.80
	160	1.88	367.65	91.74	105.48	114.97

TGV005 - DC SECTION ONLY		TOTAL OF 30 SAMPLES				
FREQUENCY BAND	HEIGHT ABOVE FLOOR (cm)	MINIMUM MAGNETIC FIELD (mG)	MAXIMUM MAGNETIC FIELD (mG)	AVERAGE MAGNETIC FIELD (mG)	STANDARD DEVIATION (mG)	COEFFICIENT OF VARIATION (%)
STATIC	10	307.50	2579.82	972.73	621.32	63.87
	60	187.79	2130.40	790.41	534.49	67.62
	110	37.21	2443.37	707.28	747.45	105.68
	160	157.74	2277.68	877.53	592.28	67.49
5-45Hz LOW FREQ	10	3.31	112.47	38.36	28.82	75.13
	60	1.97	41.95	14.59	9.97	68.37
	110	1.38	21.76	7.50	4.95	65.98
	160	1.17	13.60	5.36	3.28	61.27
50-60Hz PWR FREQ	10	1.05	59.39	10.94	16.32	149.20
	60	0.79	22.24	4.99	6.07	121.57
	110	0.76	12.95	3.36	3.49	104.02
	160	0.77	9.48	2.82	2.60	92.23
65-300Hz PWR HARM	10	0.68	14.77	6.93	4.64	66.93
	60	0.50	7.73	3.41	2.15	63.18
	110	0.51	4.80	2.01	1.22	60.81
	160	0.59	3.70	1.65	0.89	53.81
305-2560Hz HIGH FREQ	10	0.83	7.98	3.80	2.25	59.23
	60	0.78	4.62	2.33	1.14	48.91
	110	0.75	3.37	1.74	0.72	41.61
	160	0.92	3.00	1.79	0.58	32.20
5-2560Hz ALL FREQ	10	3.75	113.72	43.73	29.26	66.90
	60	2.36	42.90	16.85	10.60	62.90
	110	1.85	22.55	9.10	5.50	60.47
	160	1.88	15.34	6.85	3.78	55.17

TGV005 - TRANSITION BETWEEN DC AND AC SECTIONS					TOTAL OF 11 SAMPLES	
FREQUENCY BAND	HEIGHT ABOVE FLOOR (cm)	MINIMUM MAGNETIC FIELD (mG)	MAXIMUM MAGNETIC FIELD (mG)	AVERAGE MAGNETIC FIELD (mG)	STANDARD DEVIATION (mG)	COEFFICIENT OF VARIATION (%)
STATIC	10	420.08	1175.21	792.77	264.42	33.35
	60	115.92	1016.79	605.78	322.02	53.16
	110	235.28	771.16	506.44	159.85	31.56
	160	48.34	1076.90	620.90	362.12	58.32
5-45Hz LOW FREQ	10	3.68	19.44	8.95	4.57	51.00
	60	2.90	11.26	5.69	2.71	47.73
	110	2.38	7.79	4.08	1.78	43.64
	160	1.89	6.72	3.45	1.63	47.34
50-60Hz PWR FREQ	10	0.38	24.03	4.91	6.79	138.18
	60	0.30	9.65	2.11	2.67	126.77
	110	0.29	5.56	1.41	1.49	105.64
	160	0.28	4.18	1.16	1.12	96.32
65-300Hz PWR HARM	10	0.57	47.01	25.90	20.26	78.24
	60	0.39	18.55	10.39	7.92	76.30
	110	0.37	10.75	6.04	4.52	74.74
	160	0.27	8.12	4.60	3.43	74.43
305-2560Hz HIGH FREQ	10	0.70	5.78	3.51	2.24	63.97
	60	0.62	3.24	2.06	1.14	55.48
	110	0.58	2.13	1.48	0.71	47.97
	160	0.74	1.95	1.44	0.56	38.68
5-2560Hz ALL FREQ	10	3.84	53.95	30.11	18.75	62.25
	60	3.05	22.87	13.26	7.00	52.77
	110	2.51	13.91	8.17	3.99	48.88
	160	2.08	10.98	6.46	3.21	49.64

TGV005 - AC SECTION ONLY			TOTAL OF 34 SAMPLES			
FREQUENCY BAND	HEIGHT ABOVE FLOOR (cm)	MINIMUM MAGNETIC FIELD (mG)	MAXIMUM MAGNETIC FIELD (mG)	AVERAGE MAGNETIC FIELD (mG)	STANDARD DEVIATION (mG)	COEFFICIENT OF VARIATION (%)
STATIC	10	813.65	943.42	845.16	22.92	2.71
	60	821.28	899.43	869.80	22.26	2.56
	110	461.29	522.74	503.16	16.94	3.37
	160	829.11	933.44	881.83	29.49	3.34
5-45Hz LOW FREQ	10	8.84	37.51	22.44	6.95	30.96
	60	7.80	31.15	17.41	6.02	34.60
	110	6.60	27.55	14.49	5.21	35.95
	160	5.45	24.61	12.94	4.35	33.59
50-60Hz PWR FREQ	10	19.47	220.66	109.10	44.91	41.17
	60	15.90	210.75	106.03	42.24	39.84
	110	22.42	247.45	127.52	48.48	38.02
	160	35.67	366.56	193.17	71.79	37.17
65-300Hz PWR HARM	10	28.27	68.33	41.39	11.22	27.11
	60	14.20	33.85	23.00	4.71	20.46
	110	8.78	19.82	13.59	2.69	19.78
	160	7.51	22.67	12.33	2.98	24.20
305-2560Hz HIGH FREQ	10	5.07	10.51	7.14	1.23	17.19
	60	2.98	7.54	5.29	1.11	21.00
	110	2.82	8.07	4.91	1.38	28.17
	160	3.63	11.85	6.64	2.20	33.16
5-2560Hz ALL FREQ	10	41.74	227.36	121.13	40.96	33.81
	60	22.90	213.38	110.88	40.56	36.58
	110	25.12	248.67	129.50	47.88	36.97
	160	37.04	367.65	194.25	71.62	36.87



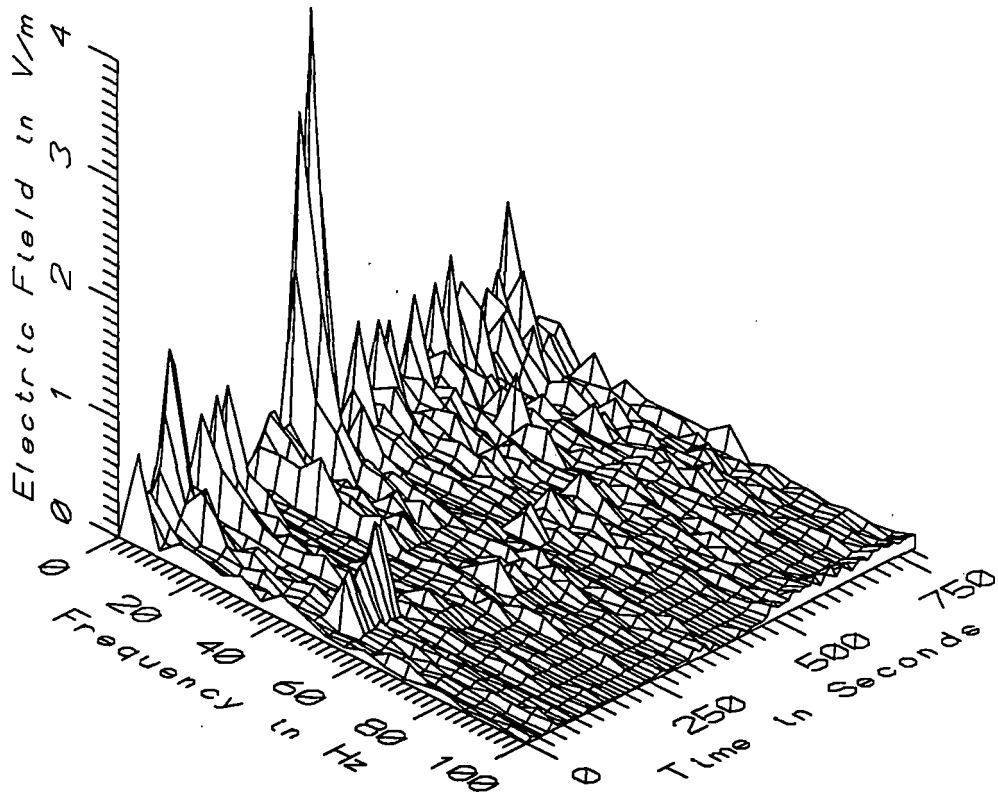

TGV005 - ELECTRIC FIELD IN TEST TRAIN LOCOMOTIVE

APPENDIX G

DATASET TGV006  
TEST TRAIN LOCOMOTIVE, AGAINST ENGINEER'S CHAIR

Measurement Setup Code:           Staff: 5           Reference: 8  
                                      Drawing: A-2

Vehicle Status:                    Locomotive trip from Tours station  
                                      to Montparnasse station in Paris

Measurement Date:                 September 8, 1992

Measurement Time:                 Start:       09:30:15  
                                      End:         09:42:02

Number of Samples:                 25

Programmed Sample Interval:       30 sec

Actual Sample Interval:            29.5 sec

Frequency Spectrum Parameters

<u>Probe Type:</u>	<u>Wideband</u>	<u>Static</u>
Maximum Frequency (Hz)	2560	64
Minimum Frequency (Hz)	5	0
Spectral Bandwidth (Hz)	5	1

Missing or Suspect Data:         None

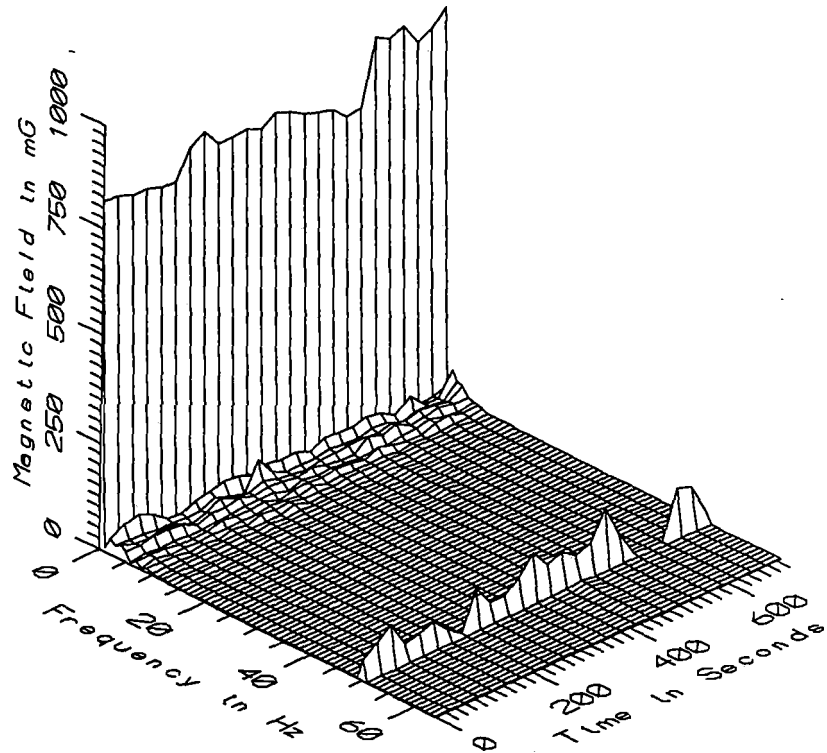

TGV006 - 10cm ABOVE FLOOR AGAINST ENGINEER'S CHAIR, PULL LOCOMOTIVE

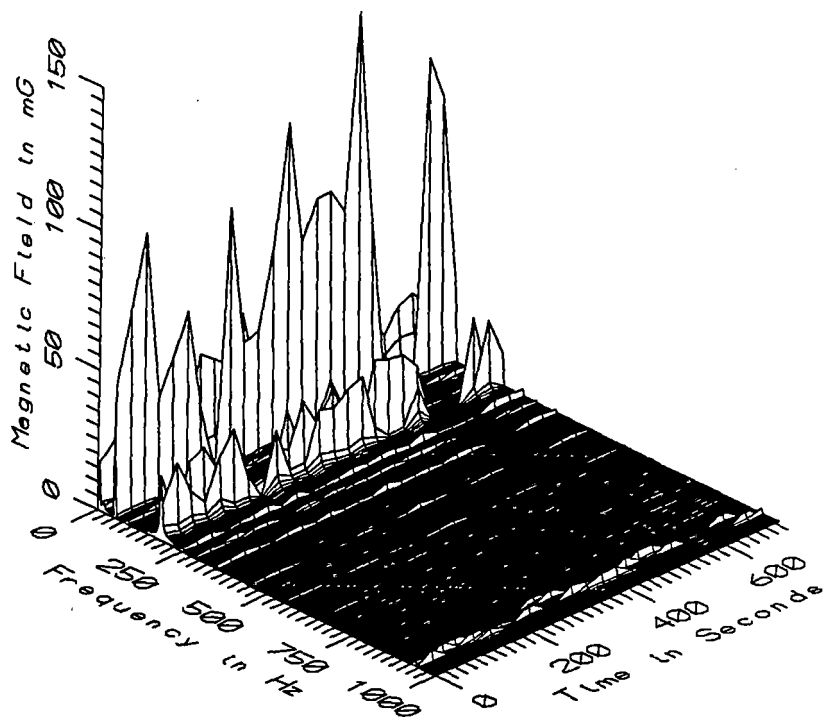

TGV006 - 10cm ABOVE FLOOR AGAINST ENGINEER'S CHAIR, PULL LOCOMOTIVE

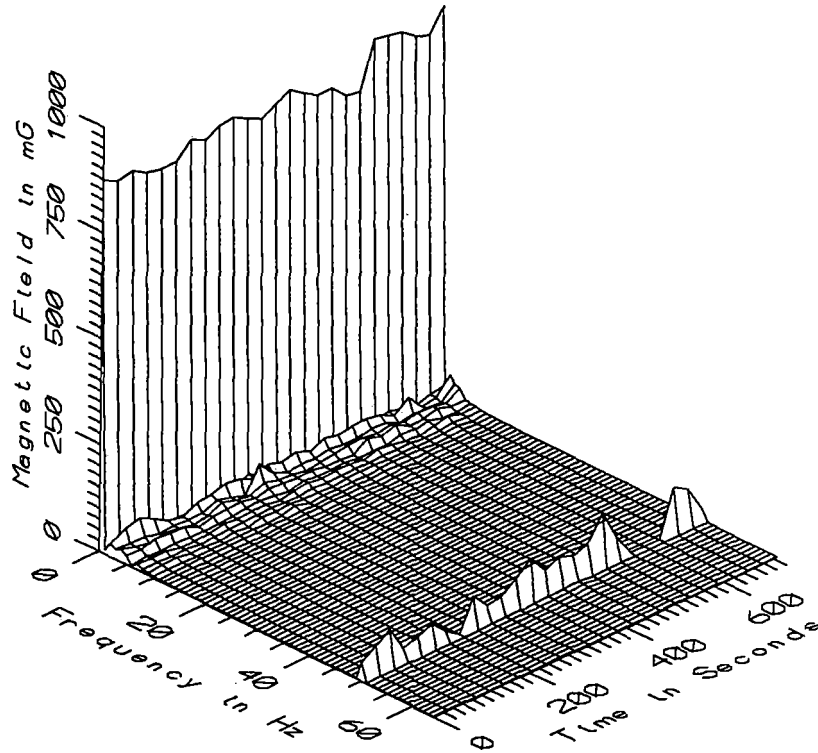

TGV006 - 60cm ABOVE FLOOR AGAINST ENGINEER'S CHAIR, PULL LOCOMOTIVE

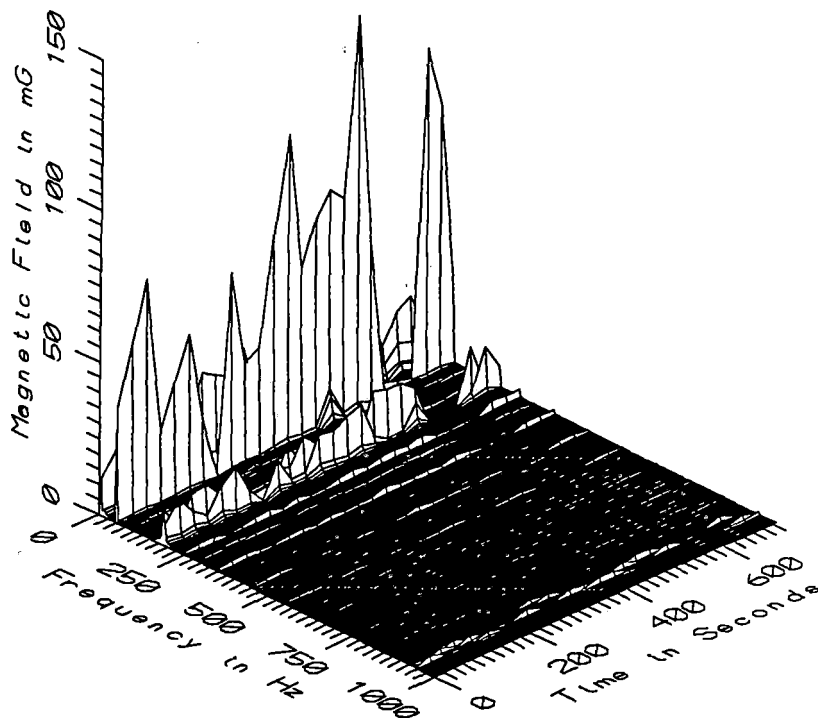

TGV006 - 60cm ABOVE FLOOR AGAINST ENGINEER'S CHAIR, PULL LOCOMOTIVE

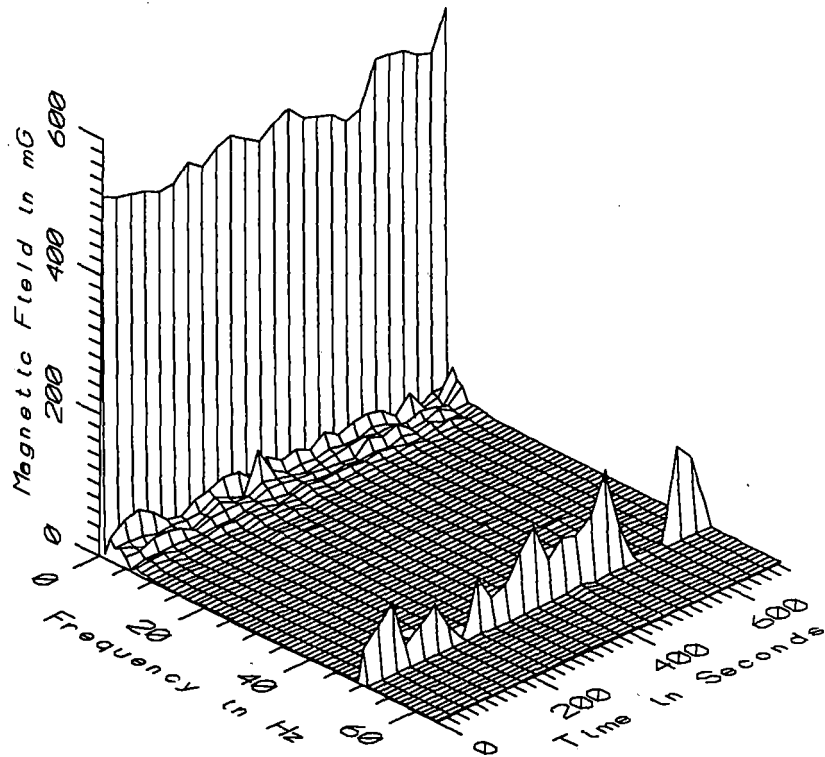

TGV006 - 110cm ABOVE FLOOR AGAINST ENGINEER'S CHAIR, PULL LOCOMOTIVE

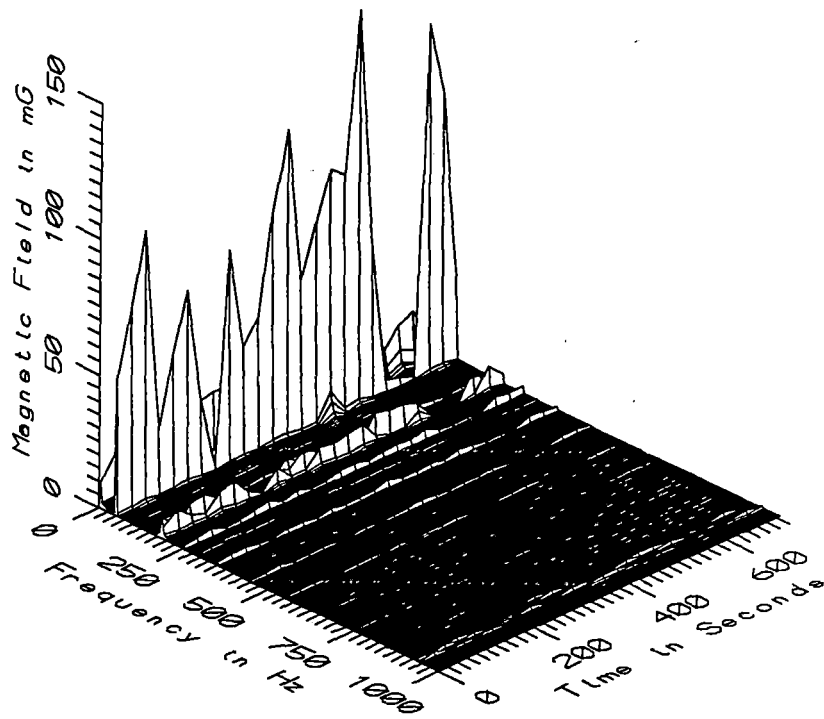

TGV006 - 110cm ABOVE FLOOR AGAINST ENGINEER'S CHAIR, PULL LOCOMOTIVE

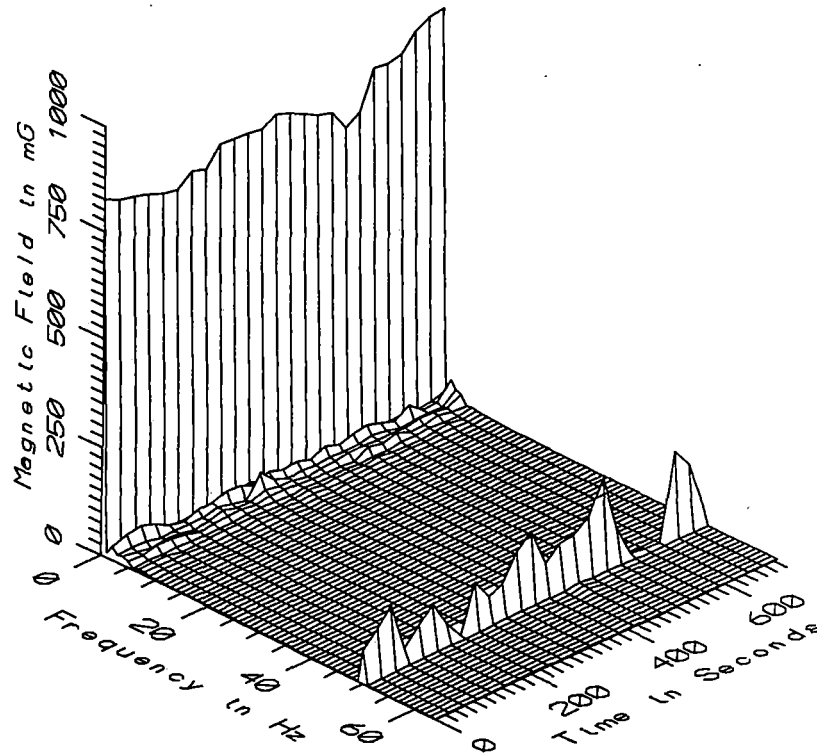

TGV006 - 160cm ABOVE FLOOR AGAINST ENGINEER'S CHAIR, PULL LOCOMOTIVE

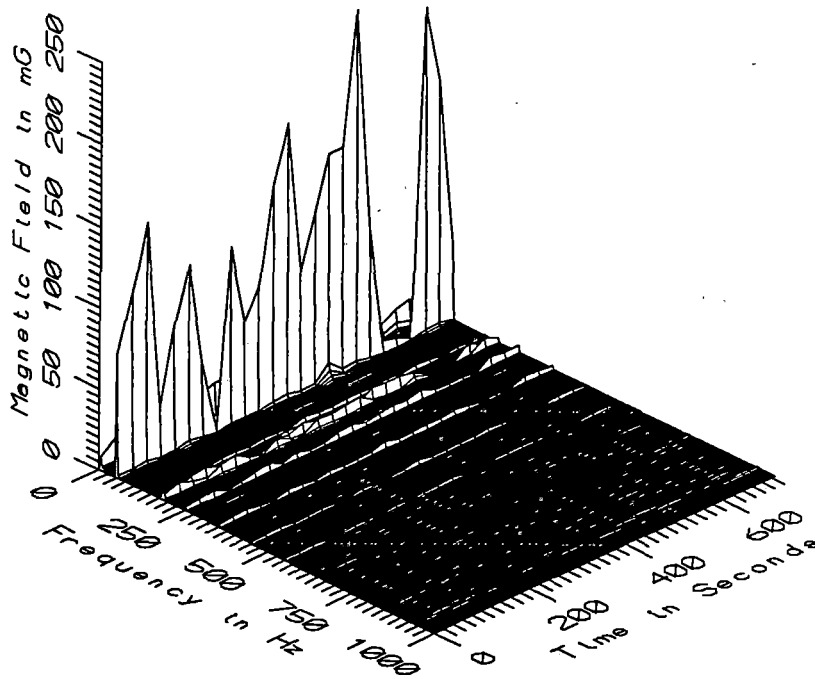

TGV006 - 160cm ABOVE FLOOR AGAINST ENGINEER'S CHAIR, PULL LOCOMOTIVE

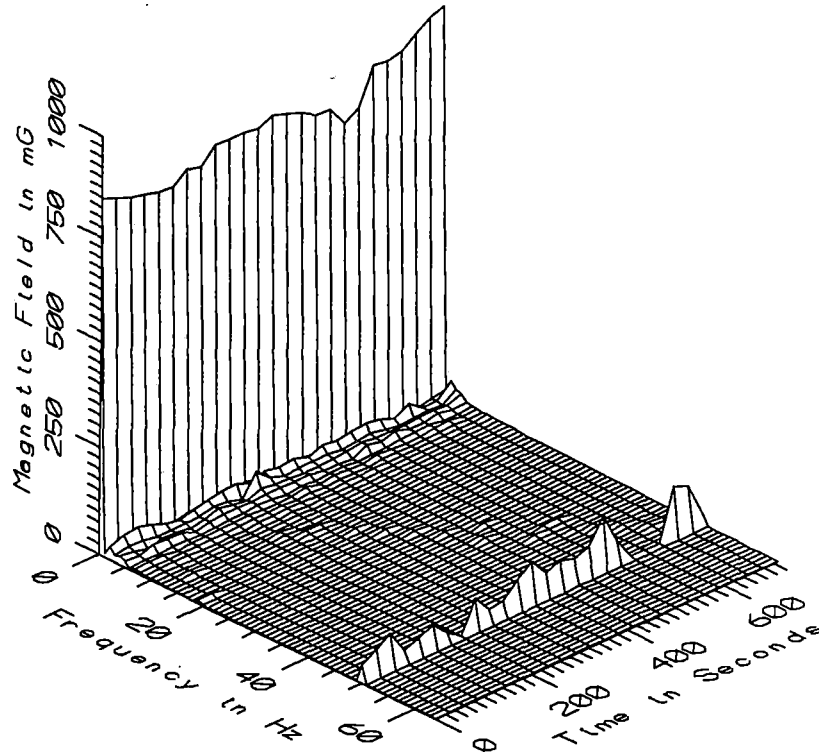

TGV006 - REF. PROBE - ASSISTANT ENGINEER'S CONSOLE, PULL LOCOMOTIVE

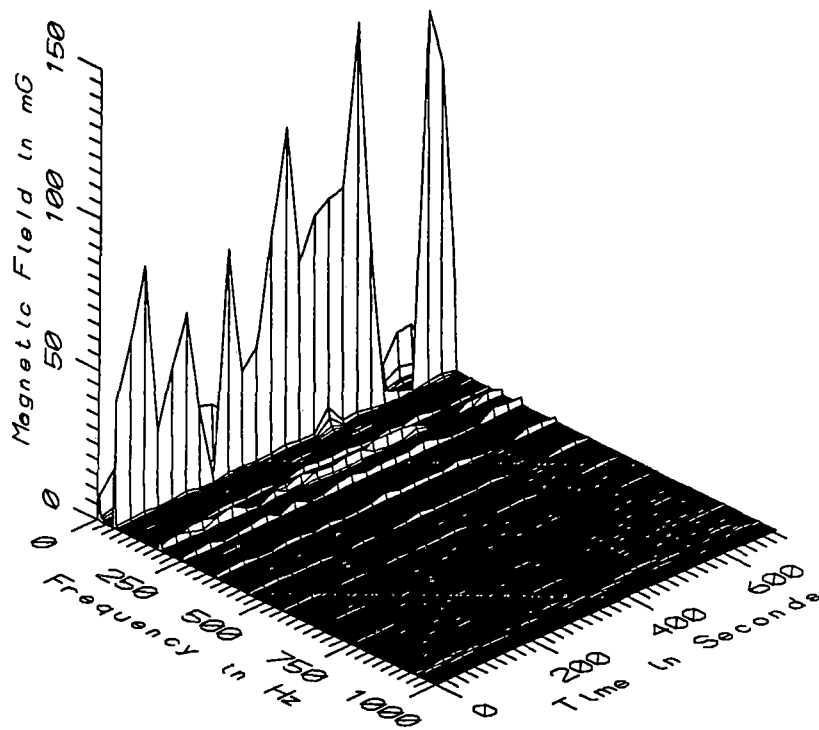

TGV006 - REF. PROBE - ASSISTANT ENGINEER'S CONSOLE, PULL LOCOMOTIVE

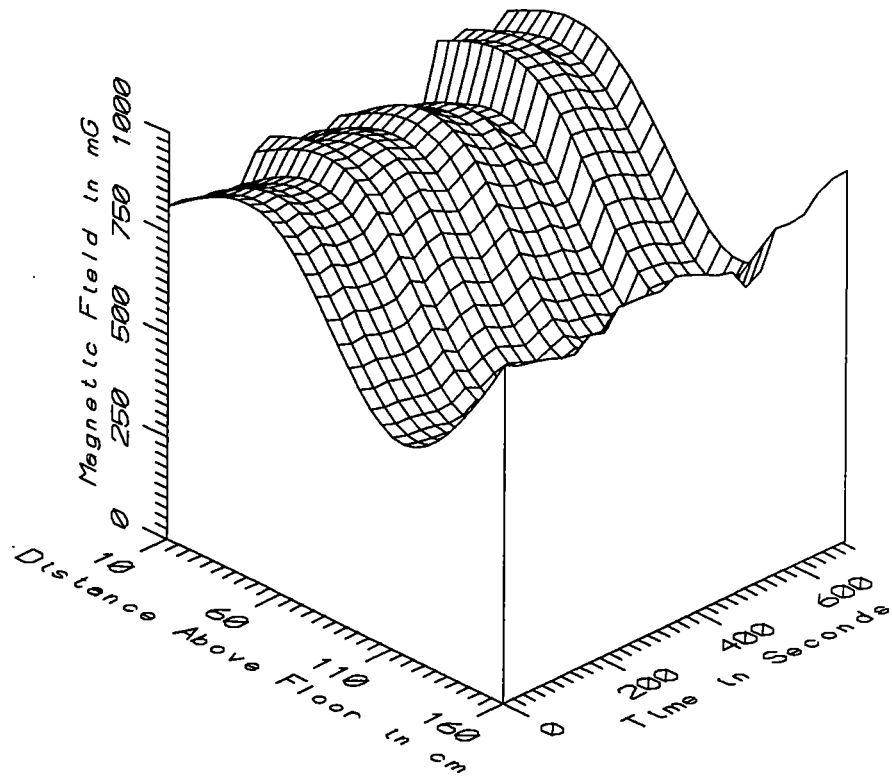

TGV006 - AGAINST ENGINEER'S CHAIR, PULL LOCOMOTIVE - STATIC

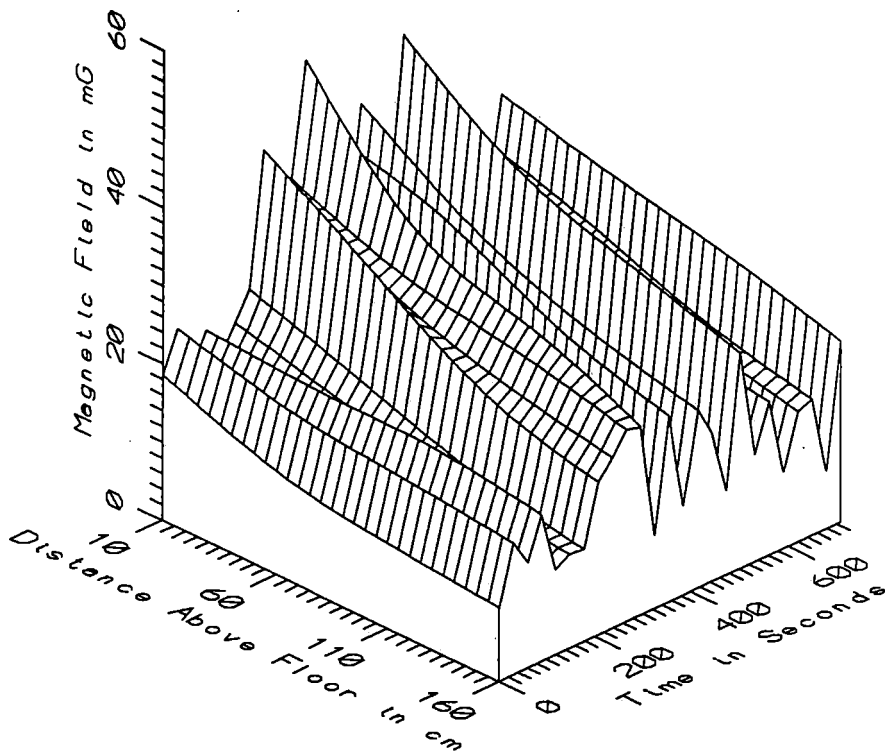

TGV006 - AGAINST ENGINEER'S CHAIR, PULL LOCOMOTIVE - LOW FREQ, 5-45Hz



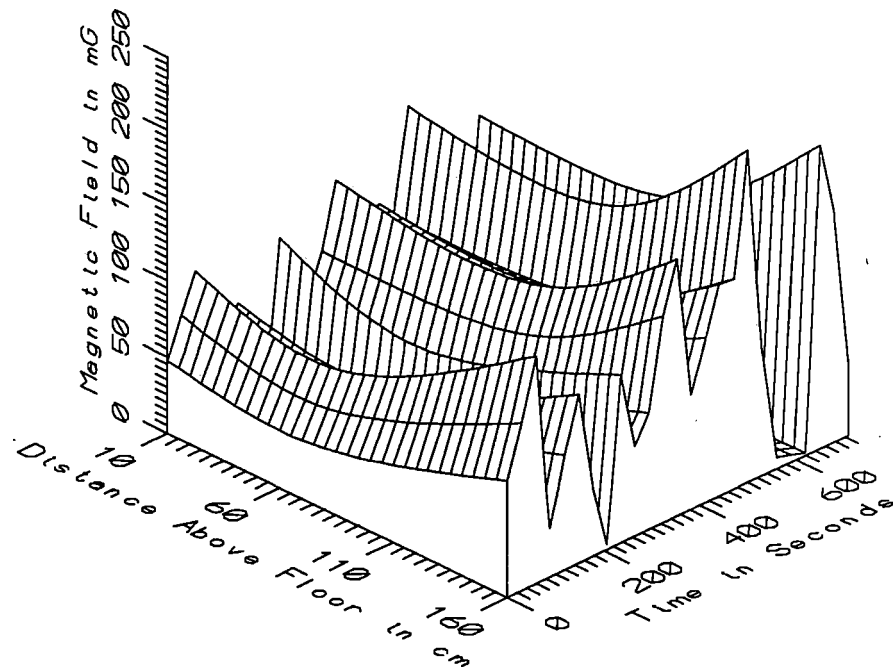

TGV006 - AGAINST ENGINEER'S CHAIR, PULL LOCOMOTIVE - POWER FREQ, 50-60Hz

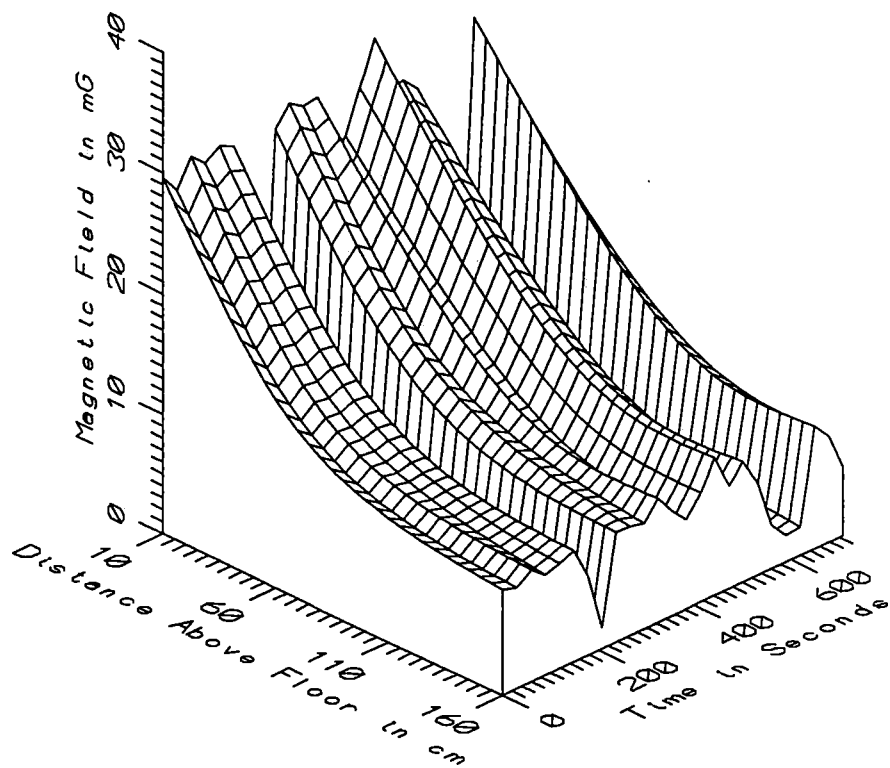

TGV006 - AGAINST ENGINEER'S CHAIR, PULL LOCOMOTIVE - POWER HARM, 65-300Hz

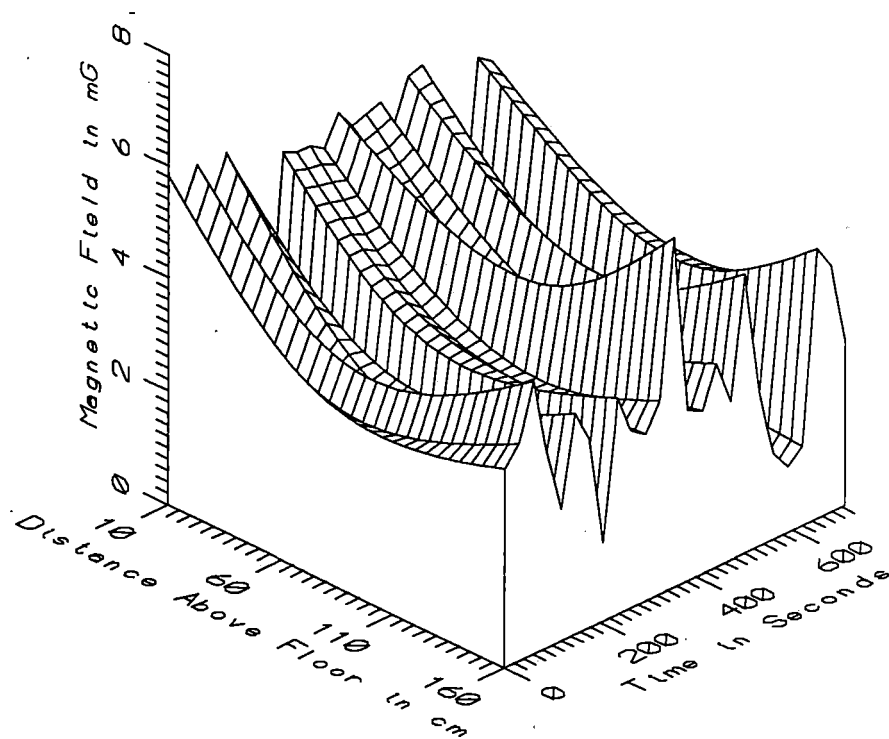

TGV006 - AGAINST ENGINEER'S CHAIR, PULL LOCOMOTIVE - HIGH FREQ, 305-2560Hz

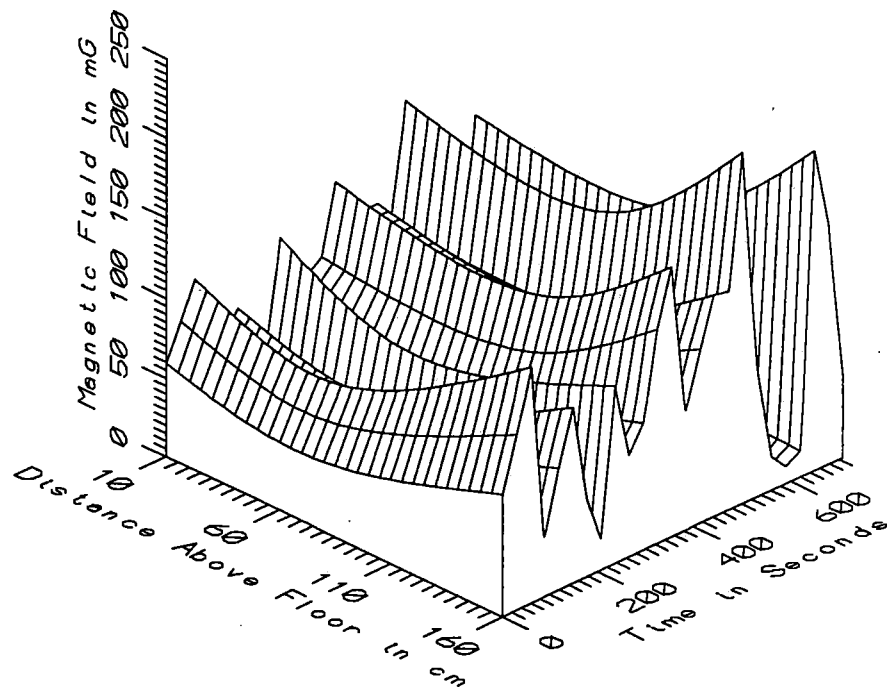

TGV006 - AGAINST ENGINEER'S CHAIR, PULL LOCOMOTIVE - ALL FREQ, 5-2560Hz

TGV006 - TEST TRAIN CAB, ALL SAMPLES IN AC SECTION					TOTAL OF 25 SAMPLES	
FREQUENCY BAND	HEIGHT ABOVE FLOOR (cm)	MINIMUM MAGNETIC FIELD (mG)	MAXIMUM MAGNETIC FIELD (mG)	AVERAGE MAGNETIC FIELD (mG)	STANDARD DEVIATION (mG)	COEFFICIENT OF VARIATION (%)
STATIC	10	764.15	922.46	836.22	46.29	5.54
	60	807.46	920.98	868.10	28.51	3.28
	110	466.61	565.52	506.75	21.62	4.27
	160	738.38	911.13	821.13	42.04	5.12
5-45Hz LOW FREQ	10	17.50	50.15	29.31	9.35	31.90
	60	13.31	37.50	23.83	7.43	31.17
	110	9.36	32.27	19.72	6.63	33.61
	160	7.53	27.65	16.81	5.84	34.73
50-60Hz PWR FREQ	10	3.18	140.84	60.59	37.46	61.82
	60	2.46	130.05	52.29	34.56	66.09
	110	1.73	146.83	62.61	40.12	64.07
	160	1.62	219.07	93.25	60.77	65.17
65-300Hz PWR HARM	10	2.50	32.77	23.53	10.15	43.14
	60	2.07	20.26	13.65	5.56	40.72
	110	1.80	12.44	8.63	3.14	36.34
	160	1.79	11.54	7.85	2.65	33.78
305-2560Hz HIGH FREQ	10	1.42	5.82	4.60	1.41	30.76
	60	1.21	4.39	3.14	0.84	26.86
	110	0.99	4.34	2.70	0.79	29.14
	160	1.15	6.16	3.26	1.20	36.84
5-2560Hz ALL FREQ	10	20.73	151.35	75.06	32.32	43.06
	60	14.85	136.48	62.14	30.05	48.37
	110	12.66	150.74	68.87	36.01	52.28
	160	11.48	221.09	97.27	57.51	59.12

APPENDIX H

DATASET TGV007  
TRANSVERSE PROFILE FROM SIDE WALL OF TEST TRAIN LOCOMOTIVE

Measurement Setup Code:           Staff: 6           Reference: 8  
  Drawing: A-2

Vehicle Status:                    Locomotive trip from Tours station  
  to Montparnasse station in Paris

Measurement Date:                 September 8, 1992

Measurement Time:                 Start:       09:43:16  
  End:         09:47:30

Number of Samples:                10

Programmed Sample Interval:       30 sec

Actual Sample Interval:           28.2 sec

Frequency Spectrum Parameters

<u>Probe Type:</u>	<u>Wideband</u>	<u>Static</u>
Maximum Frequency (Hz)	2560	64
Minimum Frequency (Hz)	5	0
Spectral Bandwidth (Hz)	5	1

Missing or Suspect Data:         None

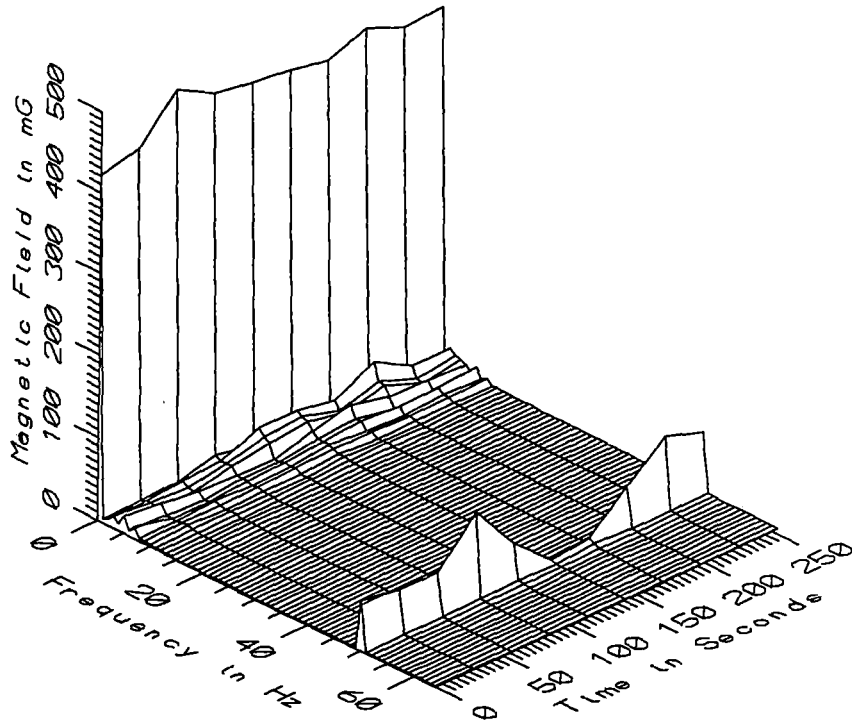

TGV007 - 10cm FROM SIDE WALL BEHIND ENGINEER'S CHAIR, PULL LOCOMOTIVE

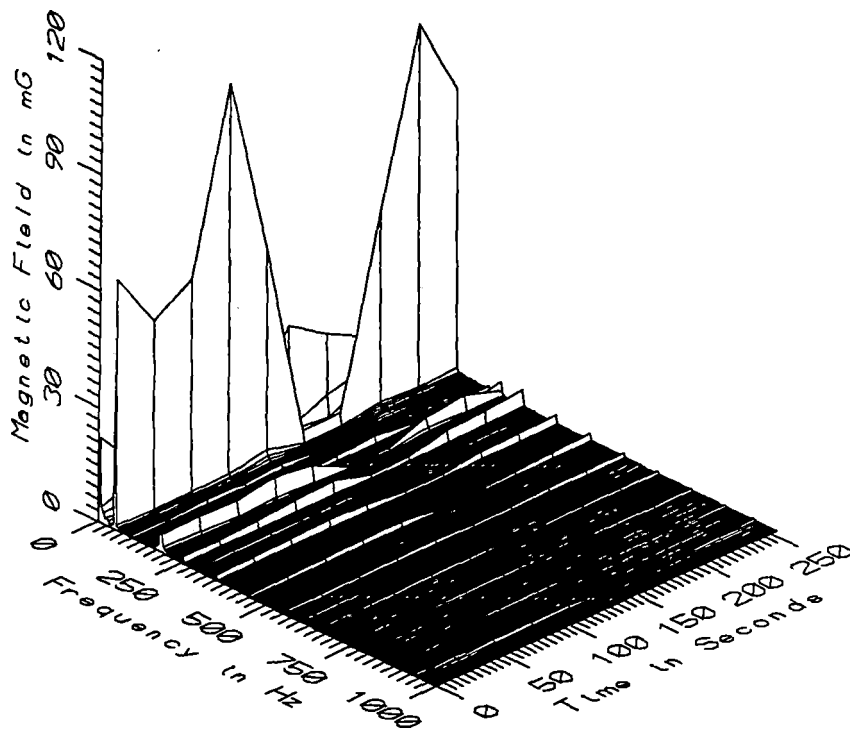

TGV007 - 10cm FROM SIDE WALL BEHIND ENGINEER'S CHAIR, PULL LOCOMOTIVE

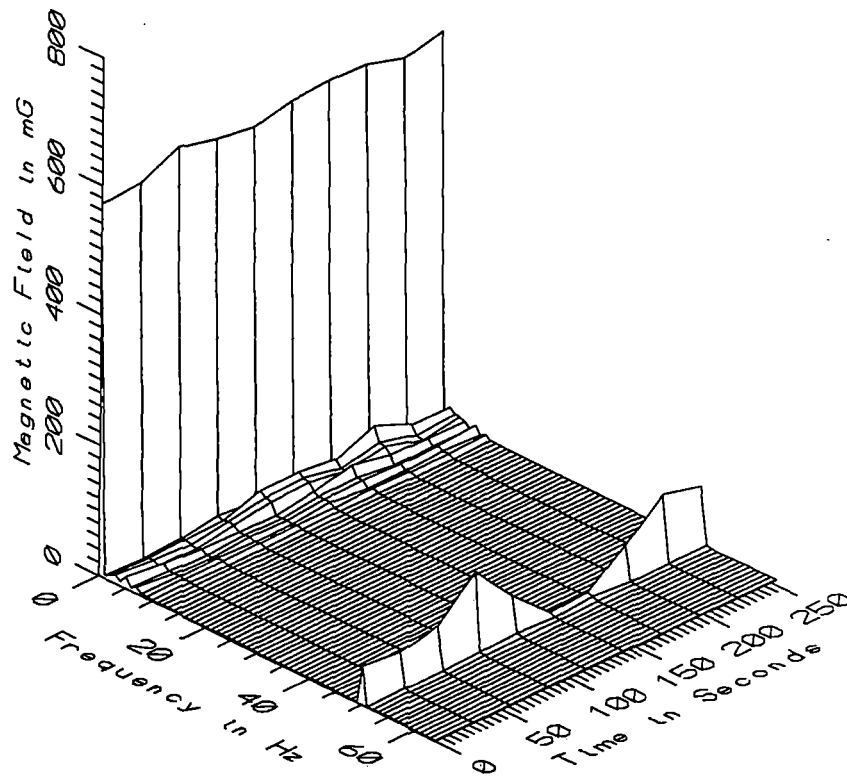

TGV007 - 60cm FROM SIDE WALL BEHIND ENGINEER'S CHAIR, PULL LOCOMOTIVE

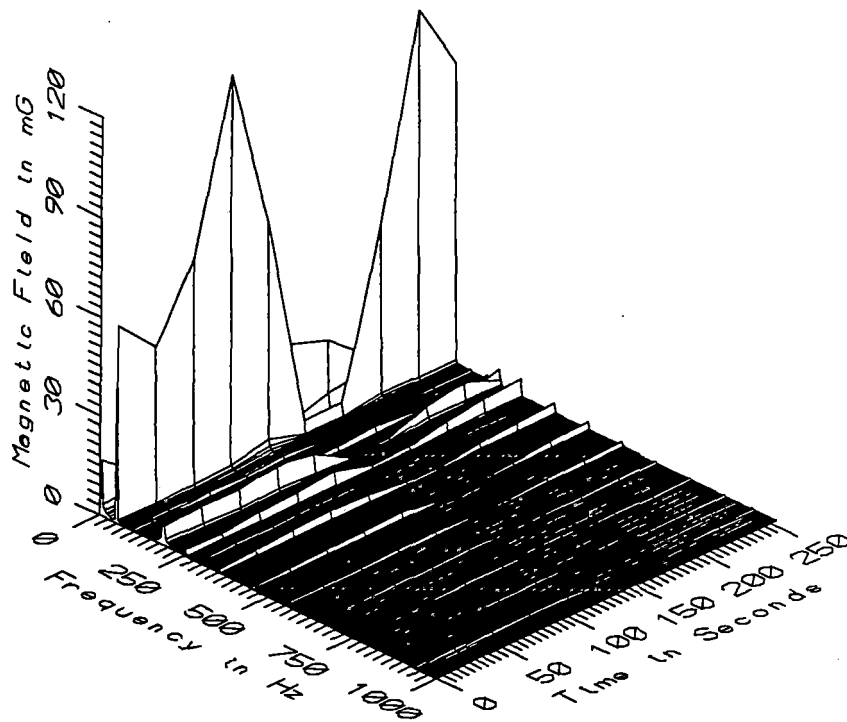

TGV007 - 60cm FROM SIDE WALL BEHIND ENGINEER'S CHAIR, PULL LOCOMOTIVE

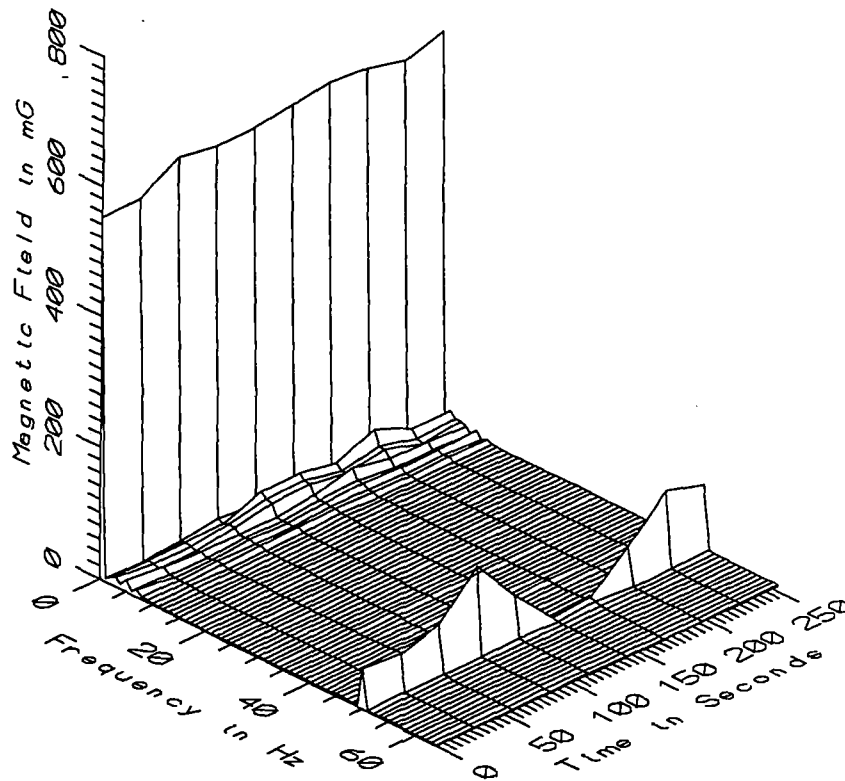

TGV007 - 110cm FROM SIDE WALL BEHIND ENGINEER'S CHAIR, PULL LOCOMOTIVE

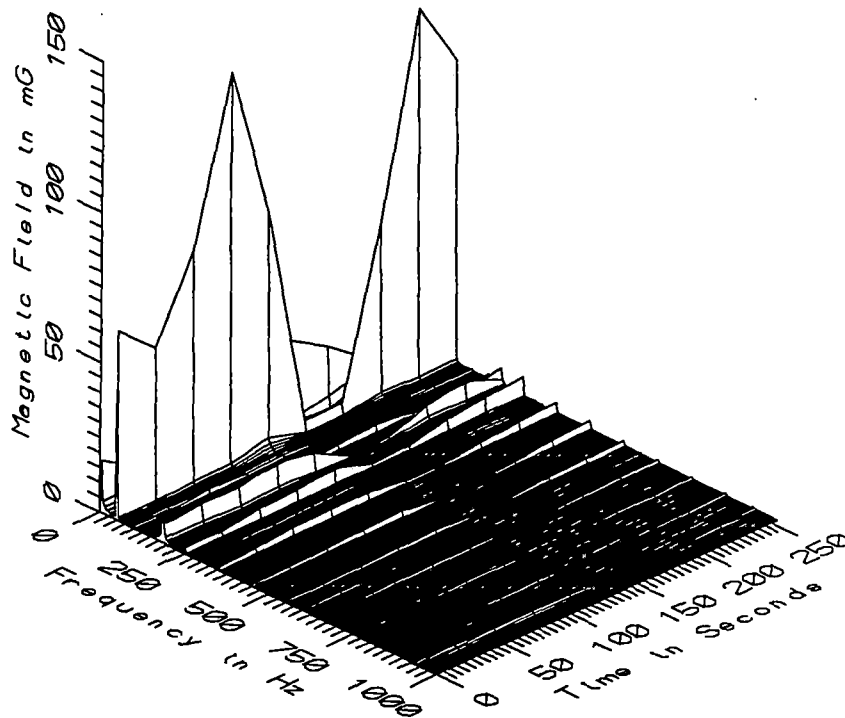

TGV007 - 110cm FROM SIDE WALL BEHIND ENGINEER'S CHAIR, PULL LOCOMOTIVE

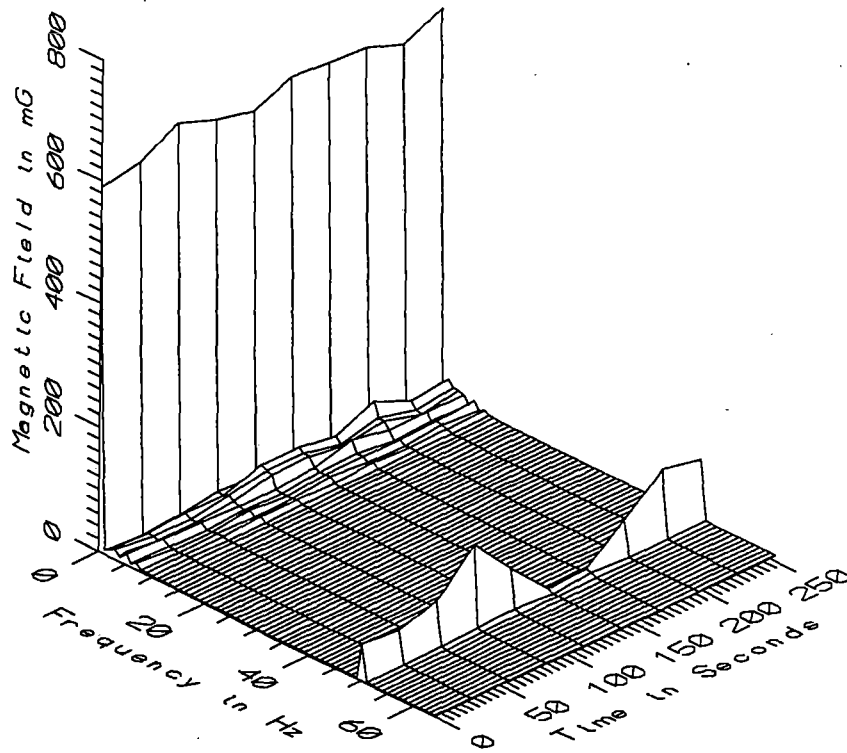

TGV007 - 160cm FROM SIDE WALL BEHIND ENGINEER'S CHAIR, PULL LOCOMOTIVE

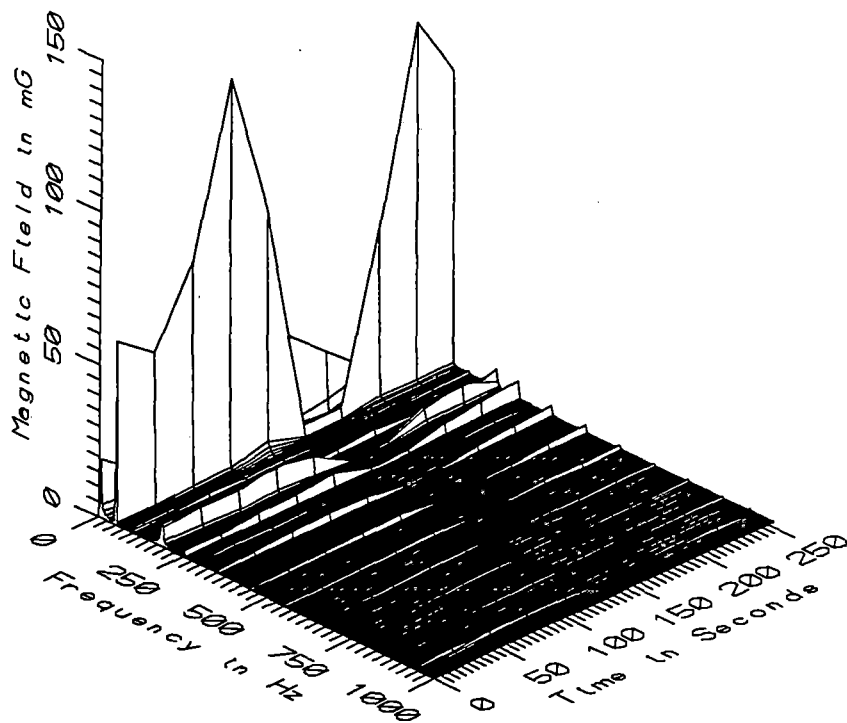

TGV007 - 160cm FROM SIDE WALL BEHIND ENGINEER'S CHAIR, PULL LOCOMOTIVE



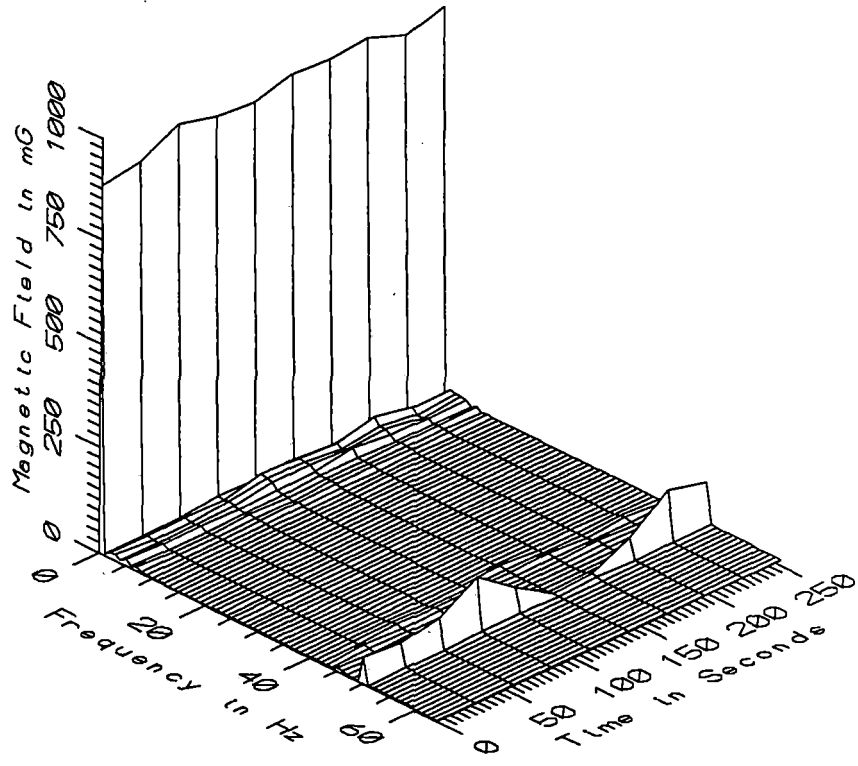

TGV007 - REF. PROBE - ASSISTANT ENGINEER'S CONSOLE, PULL LOCOMOTIVE

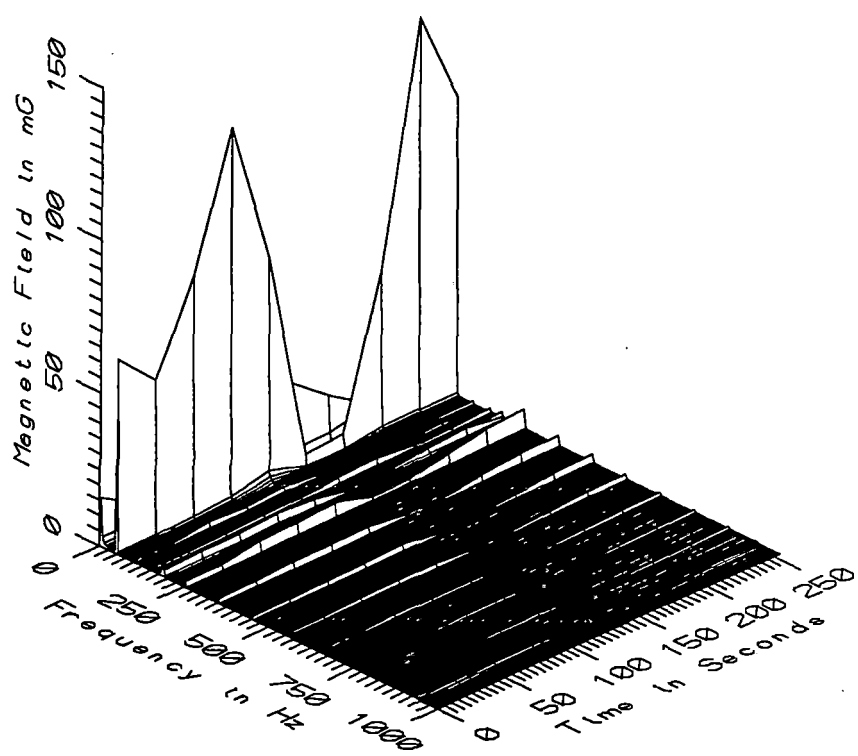

TGV007 - REF. PROBE - ASSISTANT ENGINEER'S CONSOLE, PULL LOCOMOTIVE

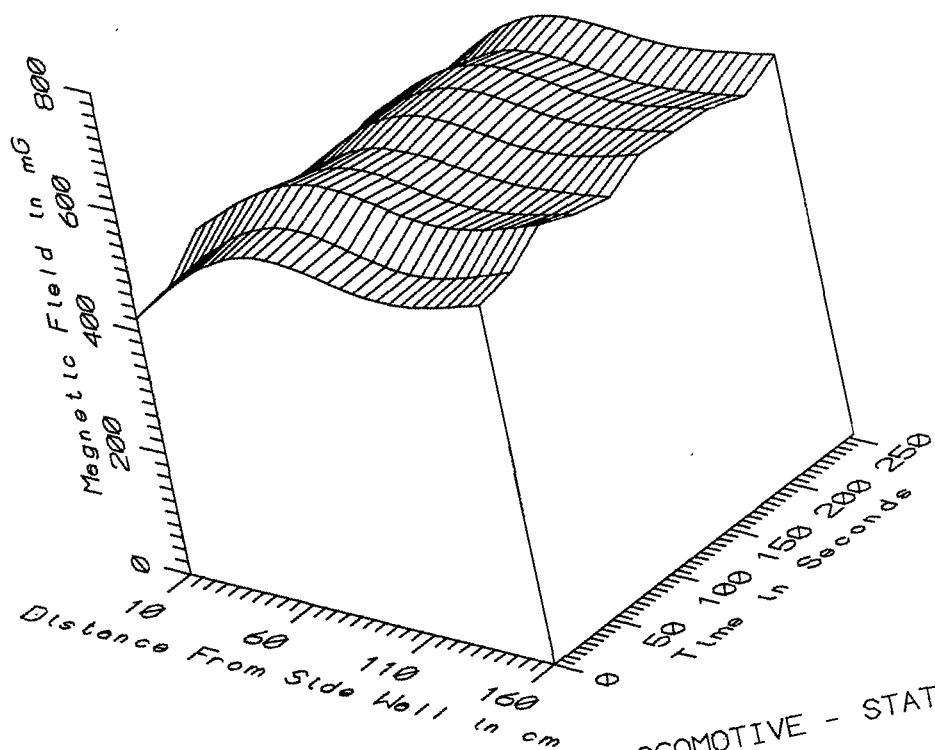

TGV007 - TRANSVERSE PROFILE IN PULL LOCOMOTIVE - STATIC

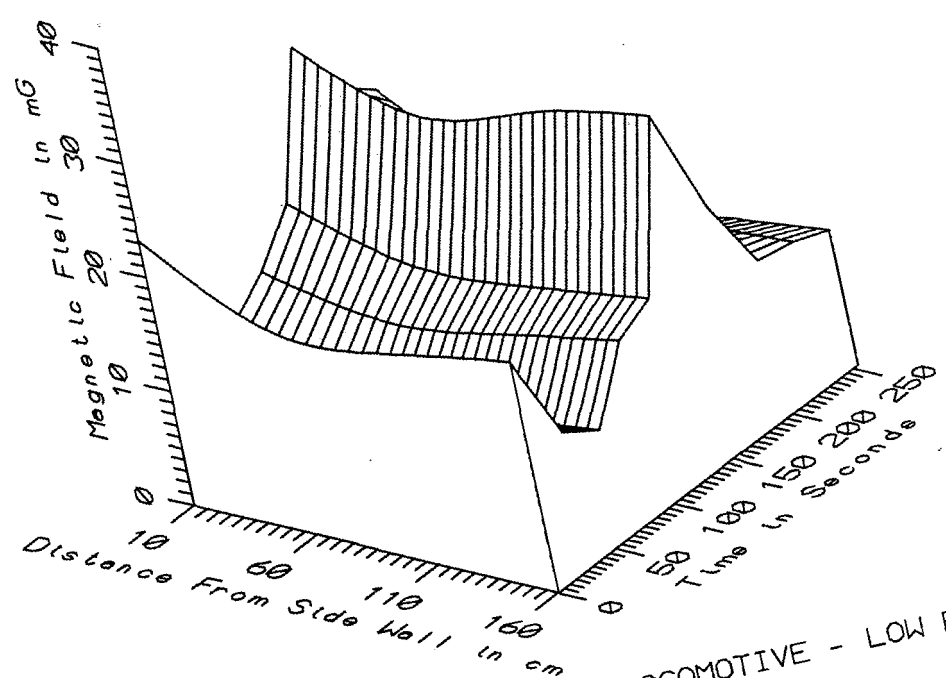

TGV007 - TRANSVERSE PROFILE IN PULL LOCOMOTIVE - LOW FREQ, 5-45Hz

151 000000  
 151 000000

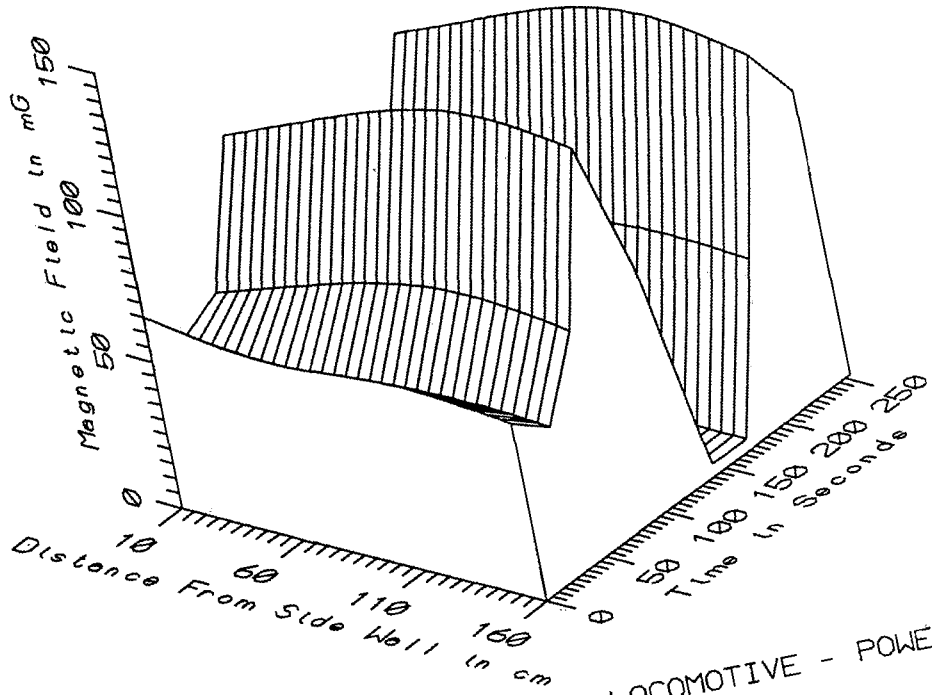

TGV007 - TRANSVERSE PROFILE IN PULL LOCOMOTIVE - POWER FREQ. 50-60Hz

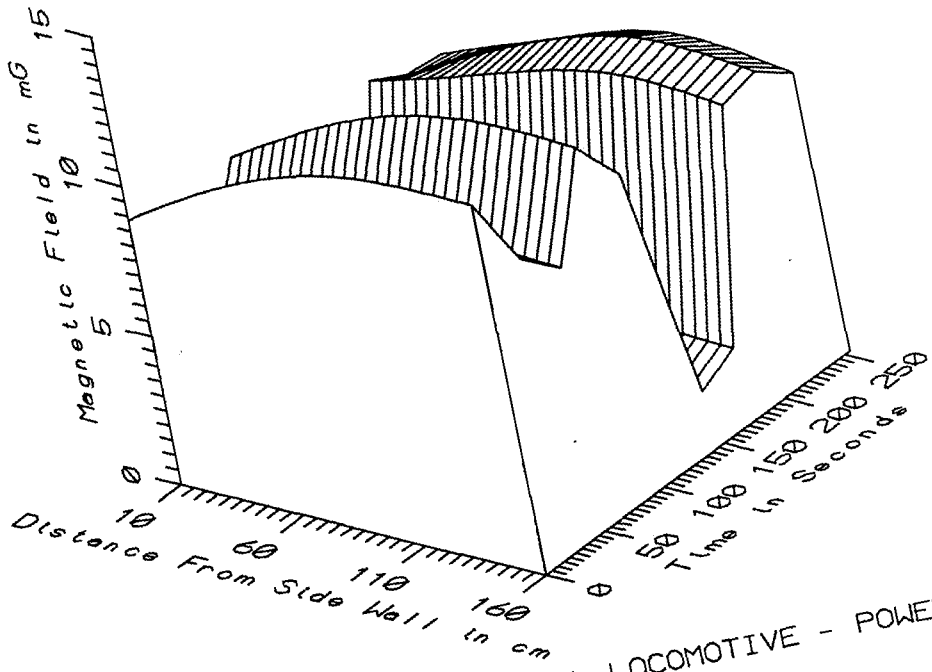

TGV007 - TRANSVERSE PROFILE IN PULL LOCOMOTIVE - POWER HARM. 65-300Hz

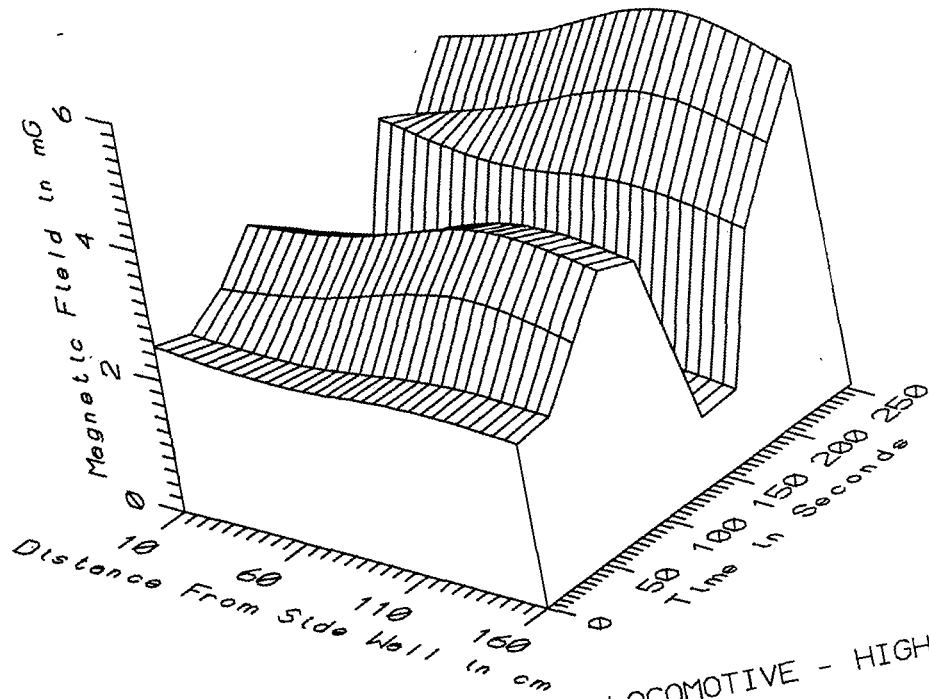

TGV007 - TRANSVERSE PROFILE IN PULL LOCOMOTIVE - HIGH FREQ, 305-2560Hz

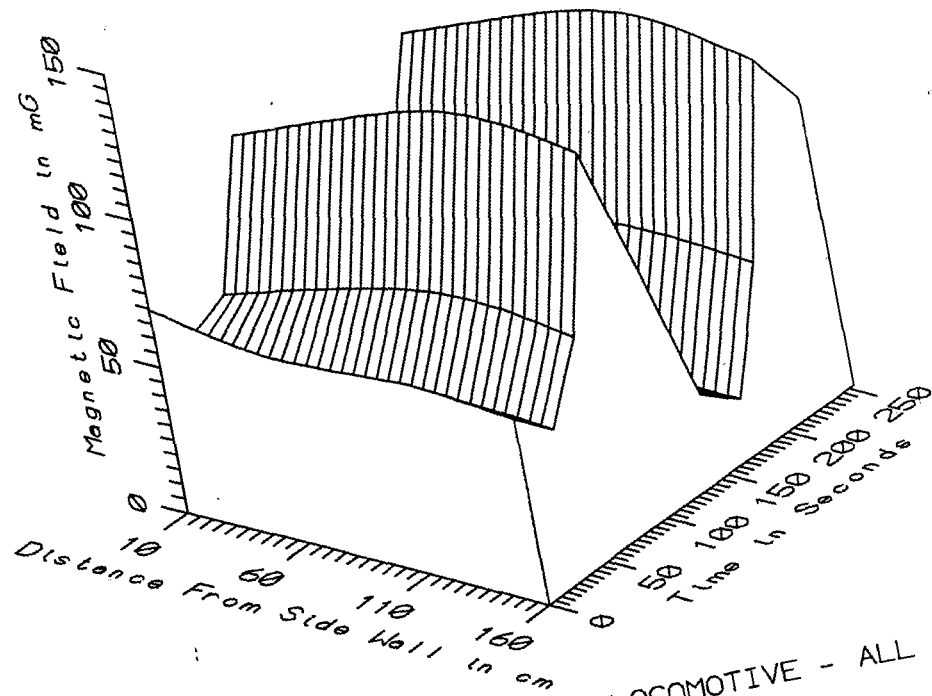

TGV007 - TRANSVERSE PROFILE IN PULL LOCOMOTIVE - ALL FREQ, 5-2560Hz

101061361131751

TGV007 - TEST TRAIN CAB, ALL SAMPLES IN AC SECTION					TOTAL OF 10 SAMPLES	
FREQUENCY BAND	DIST. FROM WALL (cm)	MINIMUM MAGNETIC FIELD (mG)	MAXIMUM MAGNETIC FIELD (mG)	AVERAGE MAGNETIC FIELD (mG)	STANDARD DEVIATION (mG)	COEFFICIENT OF VARIATION (%)
STATIC	10	421.87	484.47	446.10	17.60	3.95
	60	570.63	607.93	591.87	12.21	2.06
	110	551.01	602.12	583.82	18.09	3.10
	160	590.06	639.13	615.14	16.07	2.61
5-45Hz LOW FREQ	10	10.08	28.90	17.43	6.37	36.52
	60	8.37	25.53	14.48	5.71	39.48
	110	8.65	28.54	15.40	5.95	38.66
	160	9.97	30.87	16.48	6.17	37.41
50-60Hz PWR FREQ	10	3.66	102.37	55.57	32.70	58.83
	60	4.26	119.44	63.19	39.02	61.76
	110	4.29	131.82	69.58	43.45	62.44
	160	4.11	129.07	67.55	42.11	62.34
65-300Hz PWR HARM	10	1.78	8.87	6.28	2.37	37.79
	60	1.82	11.11	7.79	3.13	40.17
	110	2.11	12.31	8.77	3.50	39.92
	160	2.00	12.46	8.72	3.55	40.73
305-2560Hz HIGH FREQ	10	1.22	3.93	2.67	0.86	32.25
	60	0.99	4.54	2.81	1.13	40.34
	110	1.13	5.32	3.21	1.36	42.38
	160	1.02	4.92	3.04	1.28	42.08
5-2560Hz ALL FREQ	10	23.63	103.69	62.12	25.48	41.01
	60	22.22	120.56	68.61	32.89	47.94
	110	21.68	133.10	75.34	37.03	49.15
	160	21.00	130.62	73.68	35.49	48.17

APPENDIX I

DATASET TGV008  
AXIAL PROFILE FROM REAR WALL OF TEST TRAIN LOCOMOTIVE

Measurement Setup Code:        Staff: 7        Reference: 8  
   Drawing: A-2

Vehicle Status:                Locomotive trip from Tours station  
   to Montparnasse station in Paris

Measurement Date:              September 8, 1992

Measurement Time:              Start:        09:48:56  
   End:         09:53:32

Number of Samples:             10

Programmed Sample Interval:   30 sec

Actual Sample Interval:        30.7 sec

Frequency Spectrum Parameters

<u>Probe Type:</u>	<u>Wideband</u>	<u>Static</u>
Maximum Frequency (Hz)	2560	64
Minimum Frequency (Hz)	5	0
Spectral Bandwidth (Hz)	5	1

Missing or Suspect Data:        None

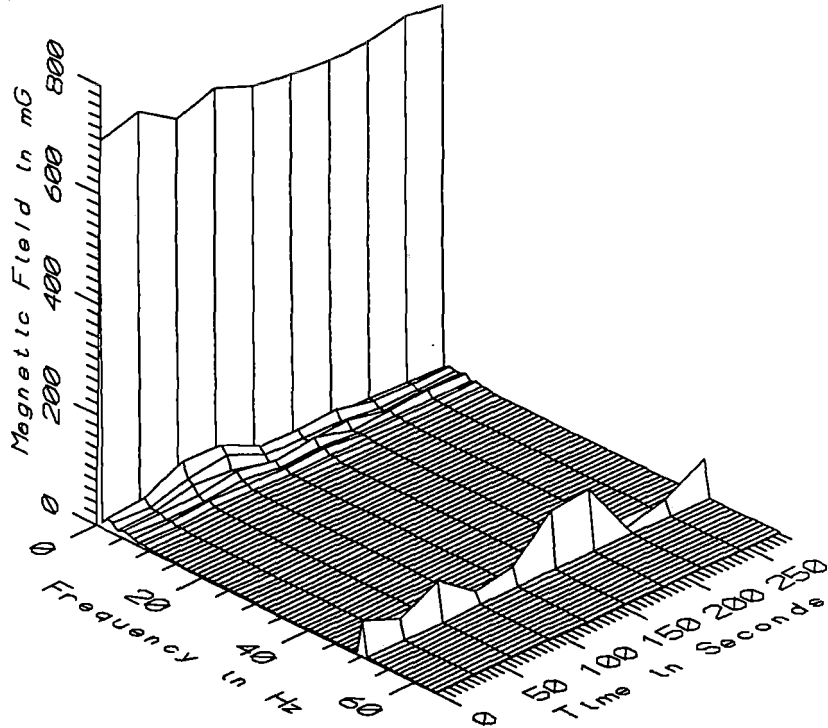

TGV008 - 10cm FROM REAR WALL BETWEEN ENGINEERS' CHAIRS, PULL LOCOMOTIVE

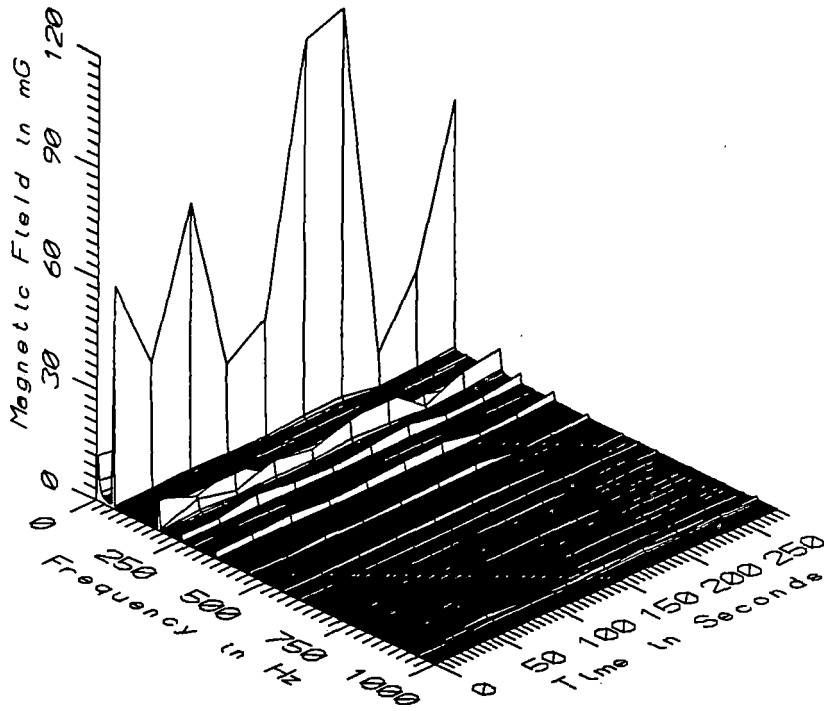

TGV008 - 10cm FROM REAR WALL BETWEEN ENGINEERS' CHAIRS, PULL LOCOMOTIVE

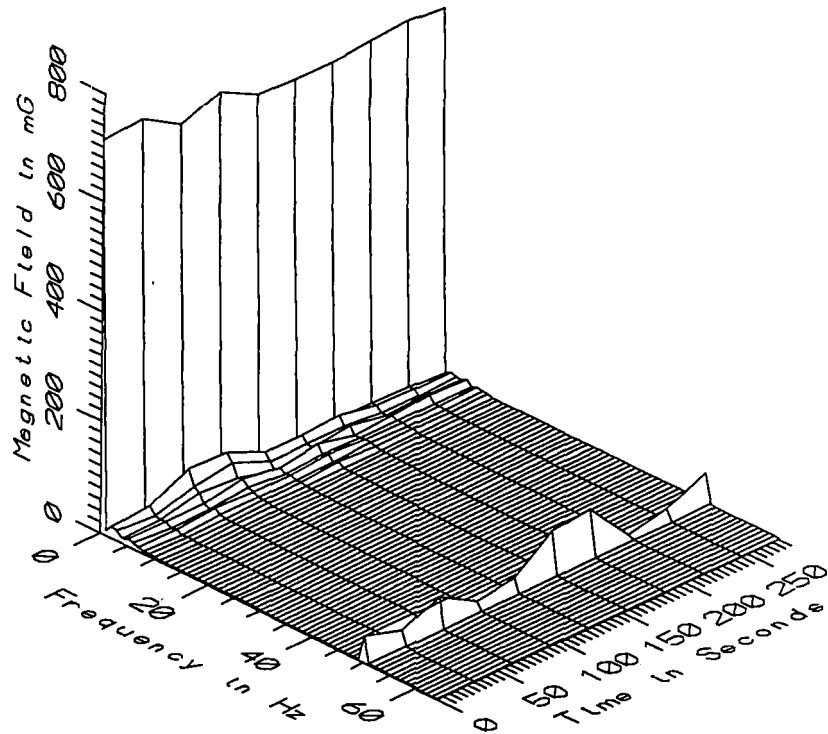

TGV008 - 60cm FROM REAR WALL BETWEEN ENGINEERS' CHAIRS, PULL LOCOMOTIVE

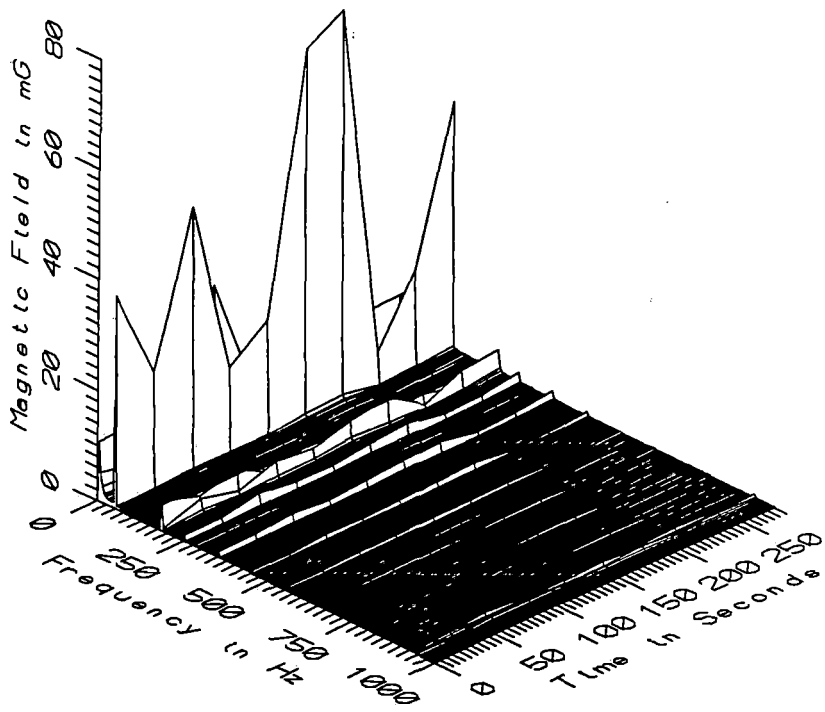

TGV008 - 60cm FROM REAR WALL BETWEEN ENGINEERS' CHAIRS, PULL LOCOMOTIVE



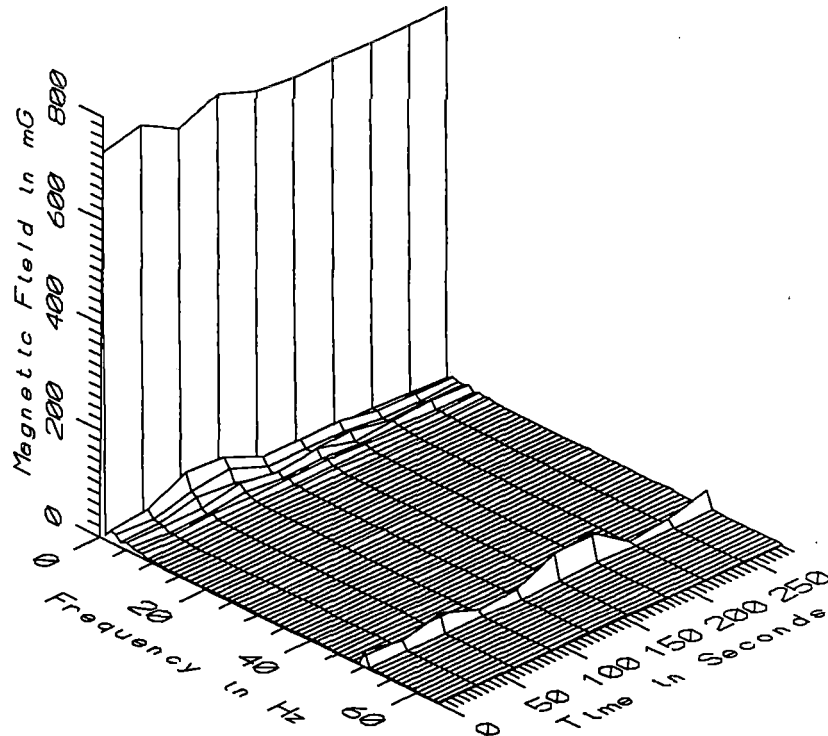

TGV008 - 110cm FROM REAR WALL BETWEEN ENGINEERS' CHAIRS, PULL LOCOMOTIVE

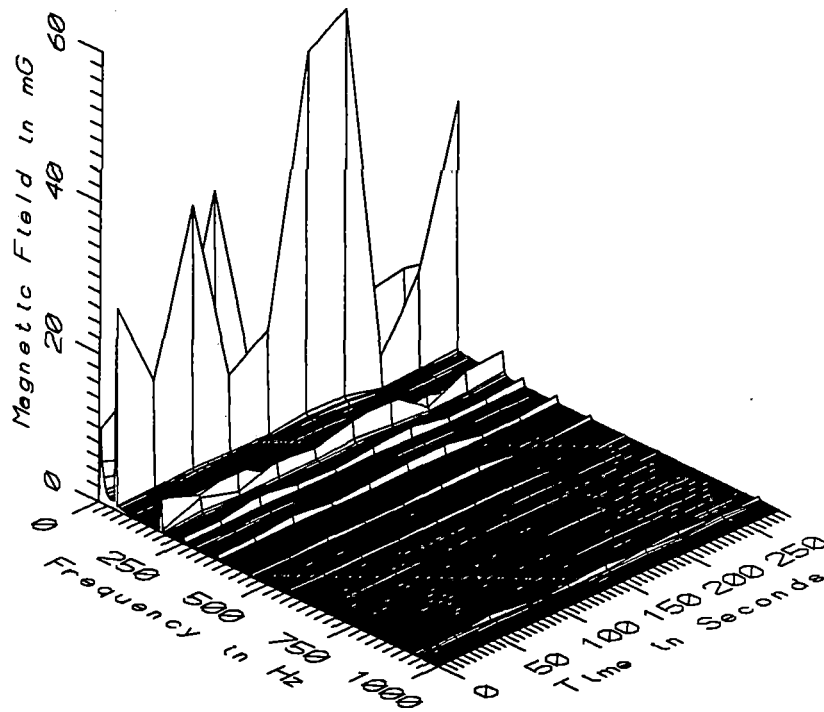

TGV008 - 110cm FROM REAR WALL BETWEEN ENGINEERS' CHAIRS, PULL LOCOMOTIVE

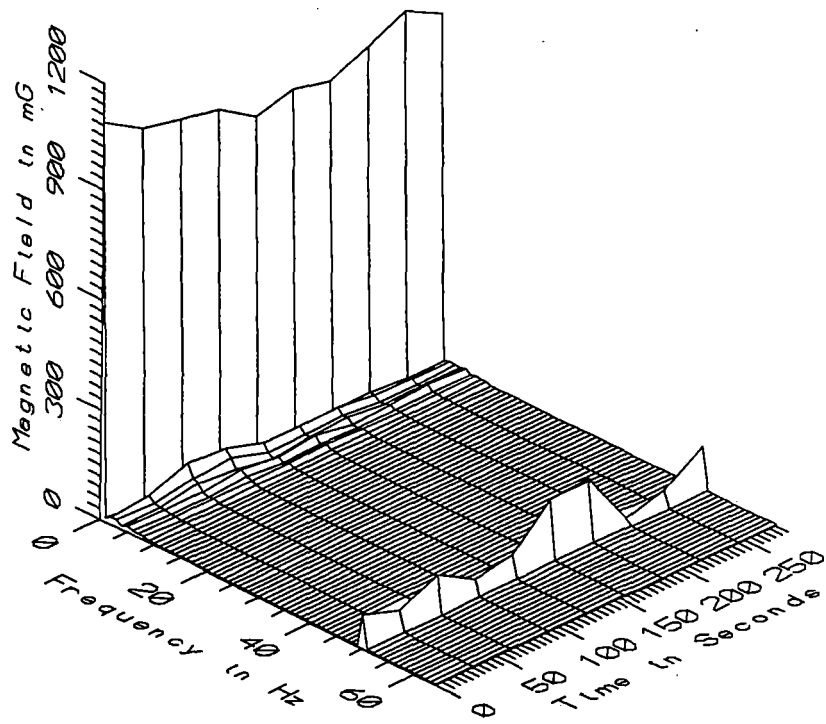

TGV008 - 160cm FROM REAR WALL BETWEEN ENGINEERS' CHAIRS, PULL LOCOMOTIVE

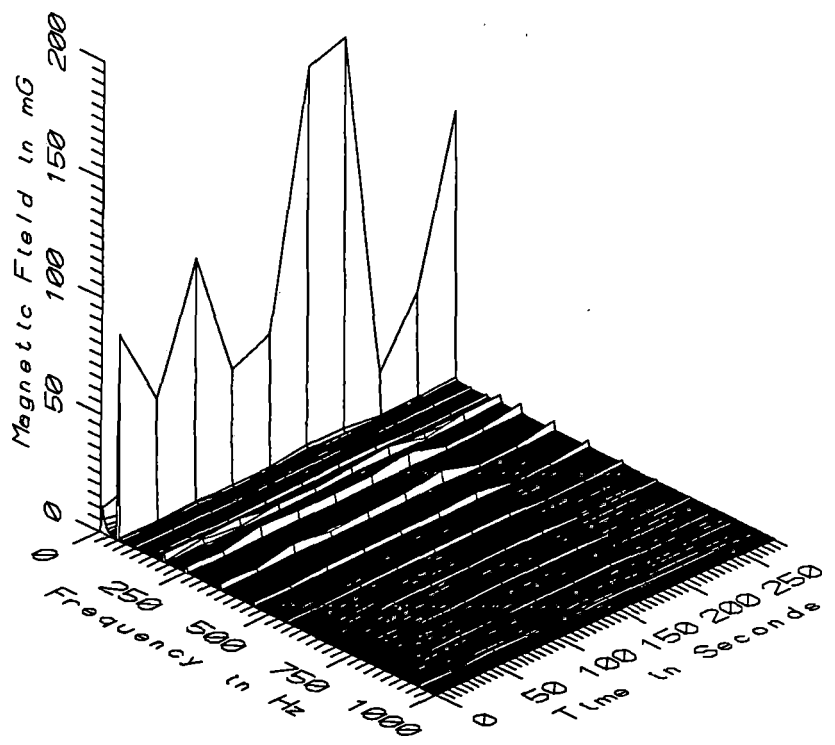

TGV008 - 160cm FROM REAR WALL BETWEEN ENGINEERS' CHAIRS, PULL LOCOMOTIVE

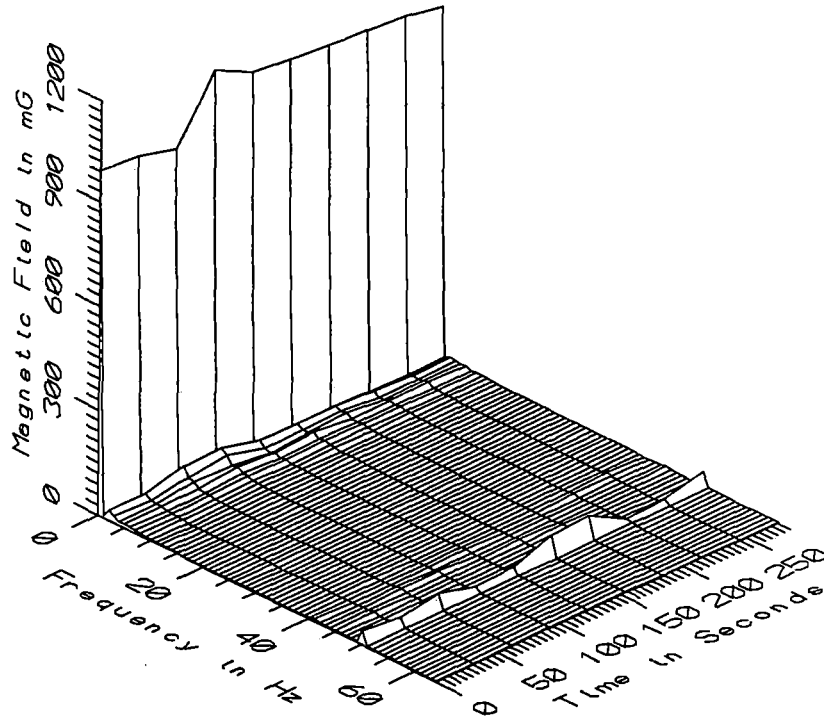

TGV008 - REF. PROBE - ASSISTANT ENGINEER'S CONSOLE, PULL LOCOMOTIVE

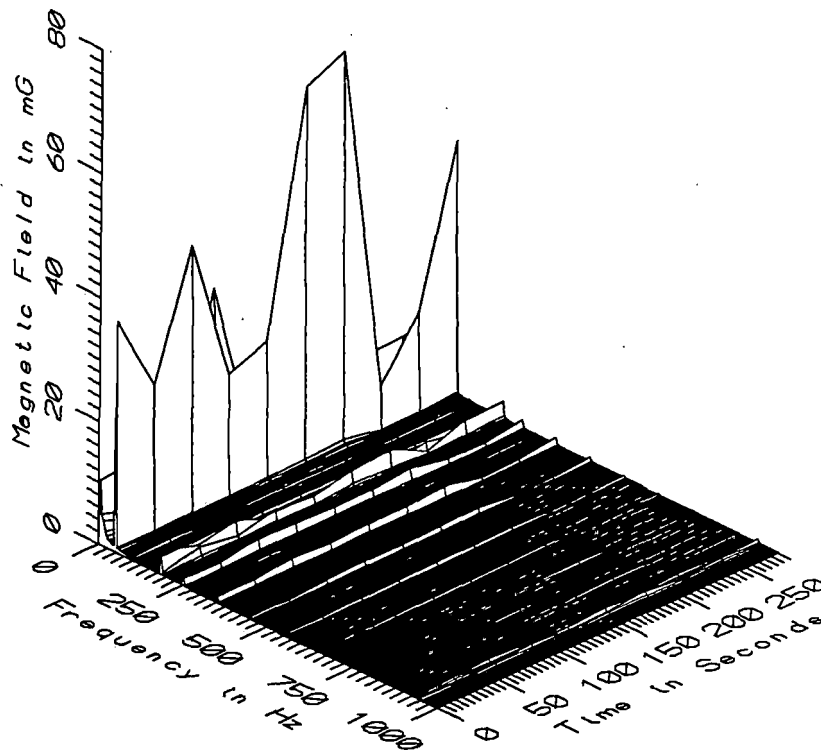

TGV008 - REF. PROBE - ASSISTANT ENGINEER'S CONSOLE, PULL LOCOMOTIVE

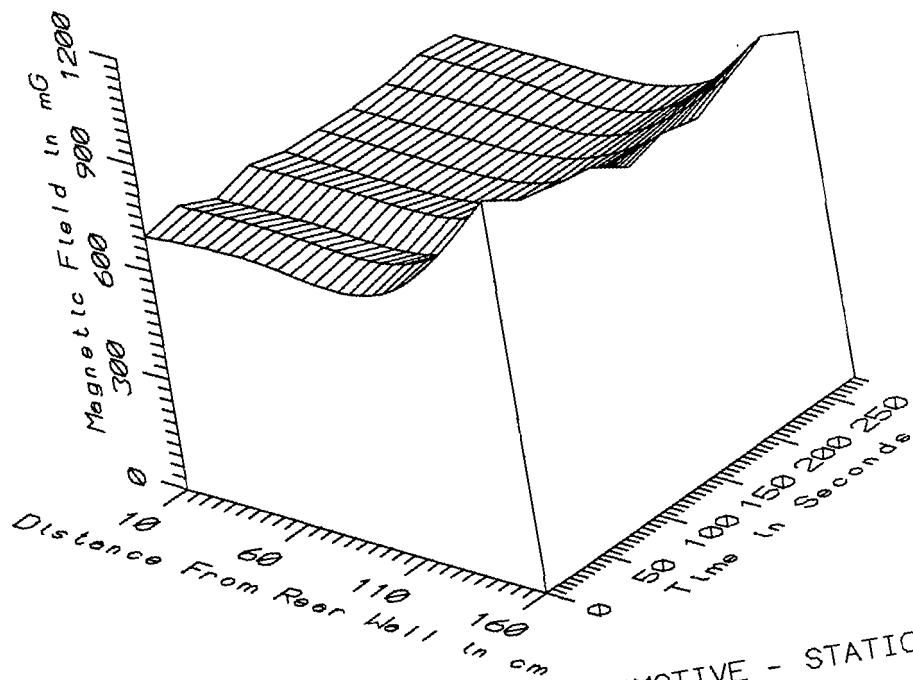

TGV008 - AXIAL PROFILE IN PULL LOCOMOTIVE - STATIC

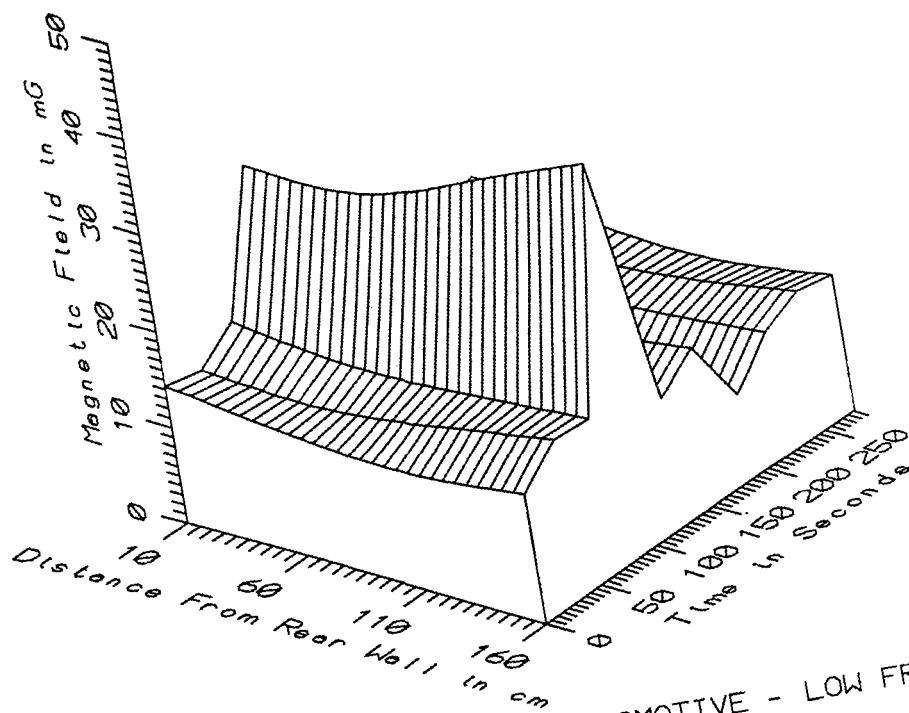

TGV008 - AXIAL PROFILE IN PULL LOCOMOTIVE - LOW FREQ. 5-45Hz

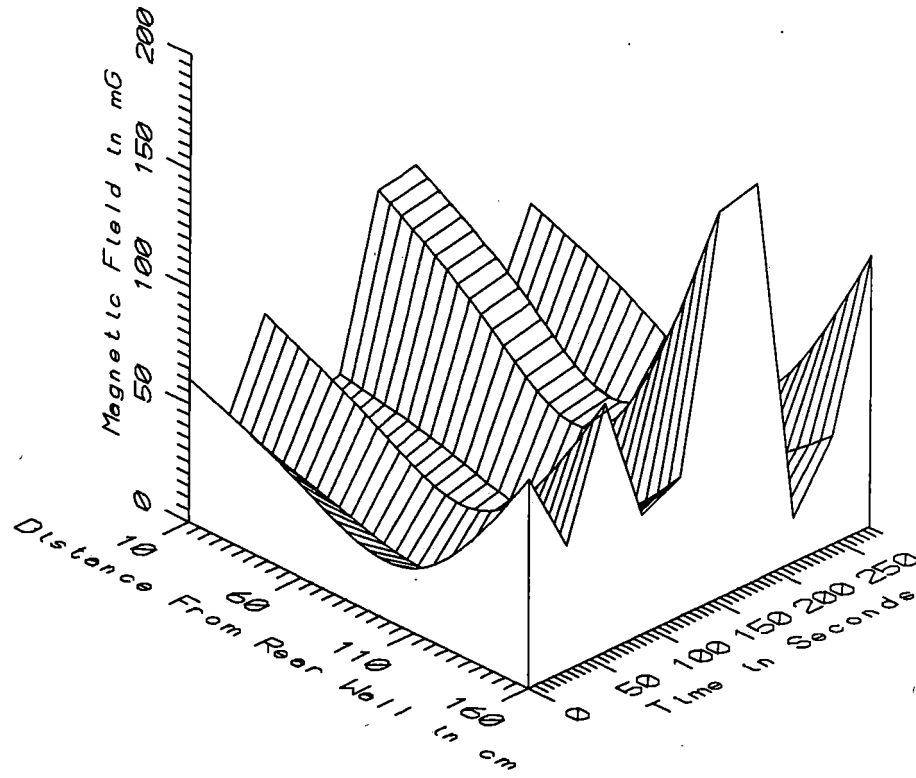

TGV008 - AXIAL PROFILE IN PULL LOCOMOTIVE - POWER FREQ, 50-60Hz

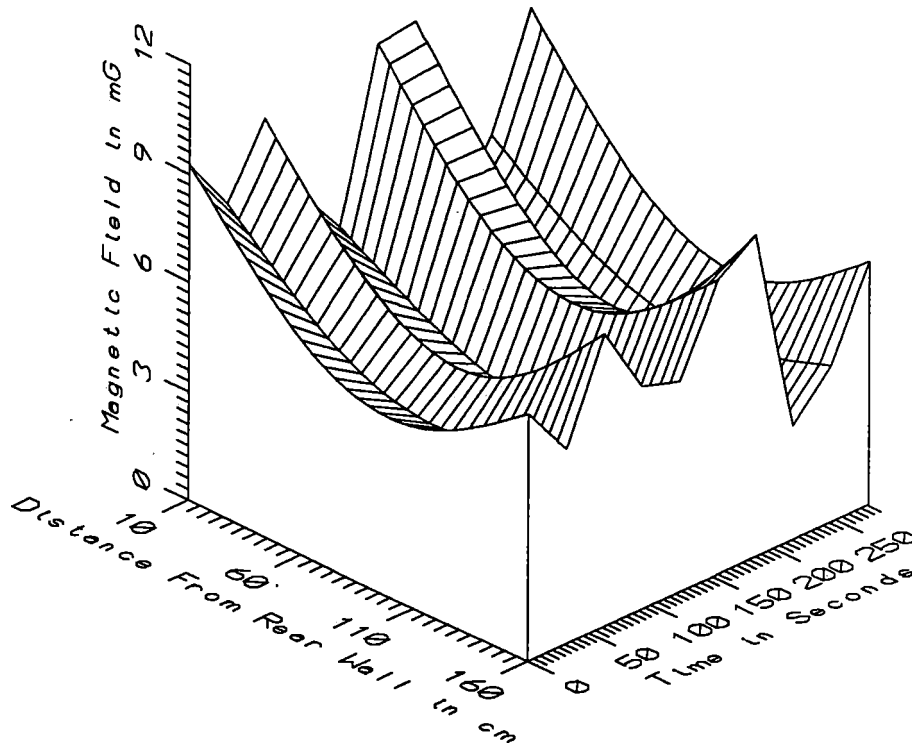

TGV008 - AXIAL PROFILE IN PULL LOCOMOTIVE - POWER HARM, 65-300Hz

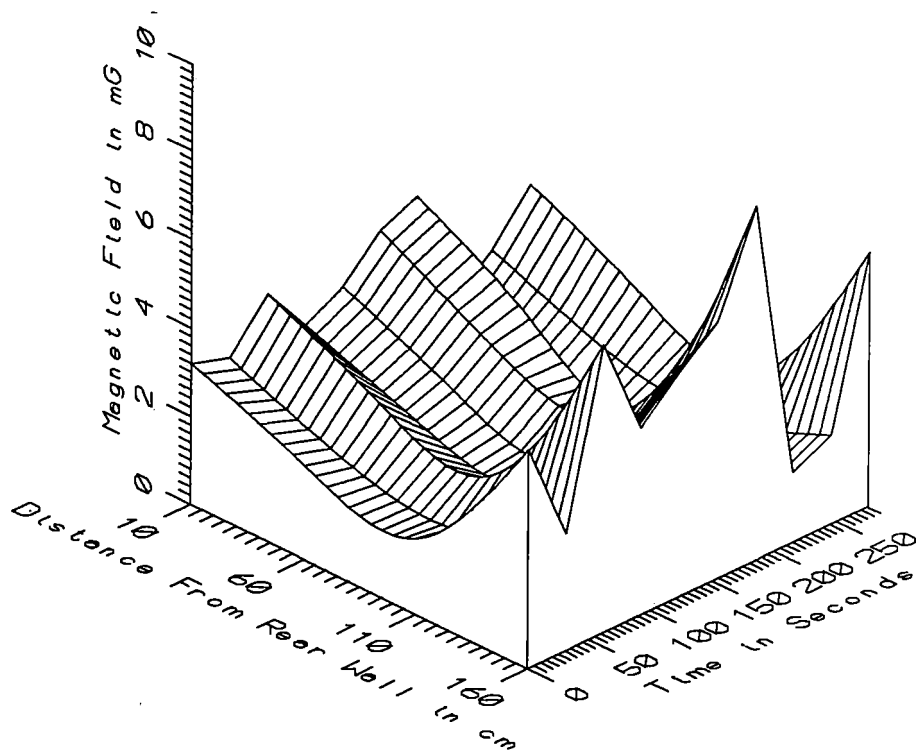

TGV008 - AXIAL PROFILE IN PULL LOCOMOTIVE - HIGH FREQ, 305-2560Hz

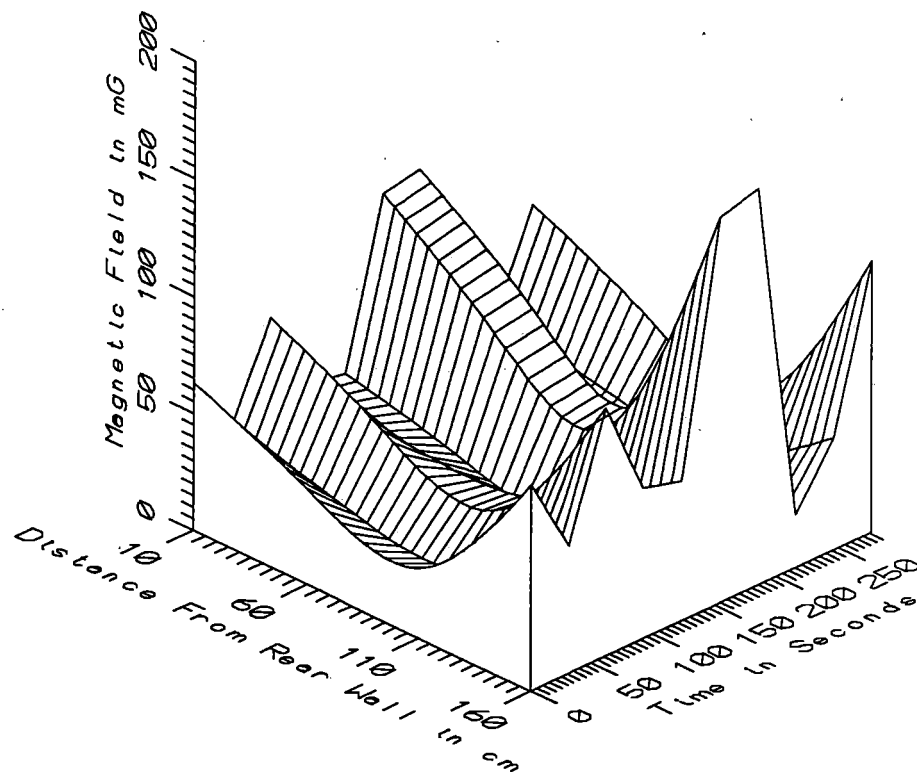

TGV008 - AXIAL PROFILE IN PULL LOCOMOTIVE - ALL FREQ, 5-2560Hz

TGV008 - TEST TRAIN CAB, ALL SAMPLES IN AC SECTION					TOTAL OF 10 SAMPLES	
FREQUENCY BAND	DIST FROM WALL (cm)	MINIMUM MAGNETIC FIELD (mG)	MAXIMUM MAGNETIC FIELD (mG)	AVERAGE MAGNETIC FIELD (mG)	STANDARD DEVIATION (mG)	COEFFICIENT OF VARIATION (%)
STATIC	10	660.29	720.55	680.51	19.53	2.87
	60	666.89	722.10	685.82	20.36	2.97
	110	710.78	749.13	721.74	14.12	1.96
	160	914.99	1088.30	981.48	52.84	5.38
5-45Hz LOW FREQ	10	8.82	29.66	14.99	5.52	36.83
	60	8.05	30.28	14.21	5.94	41.78
	110	8.49	35.35	15.10	7.40	48.97
	160	9.26	40.73	17.08	8.62	50.46
50-60Hz PWR FREQ	10	8.91	106.96	53.93	33.87	62.80
	60	6.01	71.33	35.30	22.46	63.62
	110	4.37	53.01	25.79	16.76	64.99
	160	18.82	168.97	86.69	51.10	58.95
65-300Hz PWR HARM	10	4.76	10.27	7.95	2.00	25.17
	60	2.95	6.49	5.11	1.20	23.56
	110	2.49	5.73	4.39	1.04	23.65
	160	3.18	8.92	6.40	1.78	27.87
305-2560Hz HIGH FREQ	10	1.73	4.54	3.28	0.84	25.43
	60	1.03	3.01	2.16	0.61	28.12
	110	0.81	2.39	1.72	0.50	28.95
	160	1.58	8.01	4.66	2.06	44.22
5-2560Hz ALL FREQ	10	16.21	107.91	58.11	31.52	54.23
	60	13.56	72.12	40.14	19.87	49.50
	110	12.97	53.98	32.25	14.10	43.71
	160	23.30	169.65	90.04	49.28	54.73

APPENDIX J

DATASET TGV009  
TEST TRAIN LOCOMOTIVE, AGAINST ENGINEER'S CHAIR

Measurement Setup Code:           Staff: 5           Reference: 8  
  Drawing: A-2

Vehicle Status:                    Locomotive trip from Tours station  
  to Montparnasse station in Paris

Measurement Date:                 September 8, 1992

Measurement Time:                 Start:       09:55:52  
  End:         10:14:02

Number of Samples:                38

Programmed Sample Interval:       30 sec

Actual Sample Interval:           29.5 sec

Frequency Spectrum Parameters

<u>Probe Type:</u>	<u>Wideband</u>	<u>Static</u>
Maximum Frequency (Hz)	2560	64
Minimum Frequency (Hz)	5	0
Spectral Bandwidth (Hz)	5	1

Missing or Suspect Data:         None



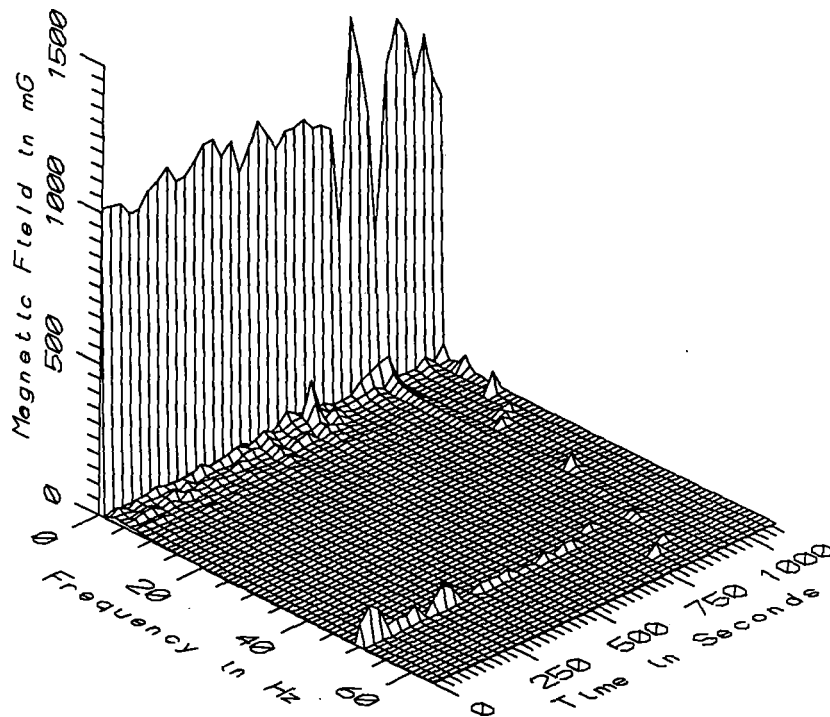

TGV009 - 10cm ABOVE FLOOR AGAINST ENGINEER'S CHAIR, PULL LOCOMOTIVE

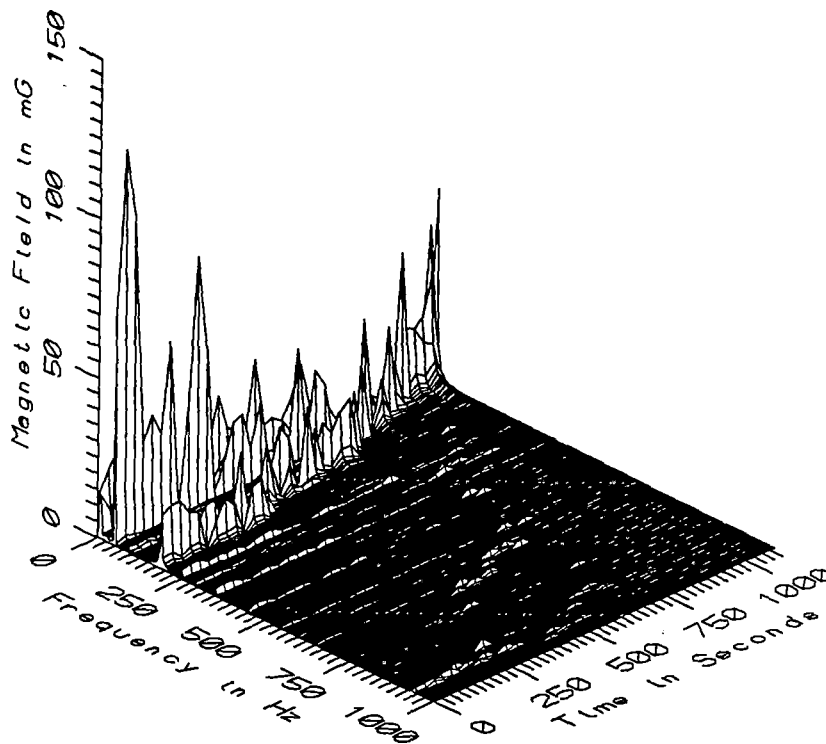

TGV009 - 10cm ABOVE FLOOR AGAINST ENGINEER'S CHAIR, PULL LOCOMOTIVE

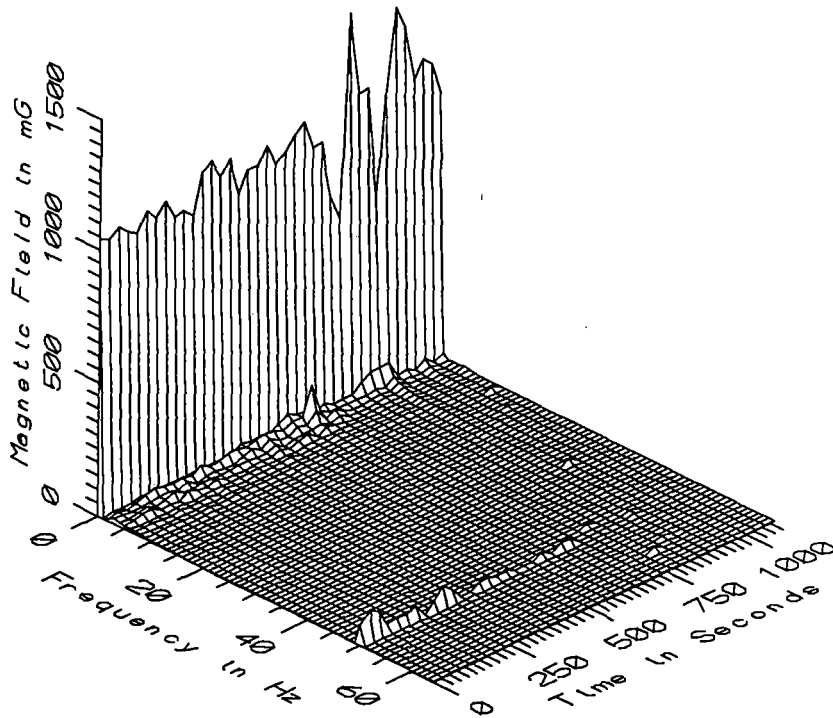

TGV009 - 60cm ABOVE FLOOR AGAINST ENGINEER'S CHAIR, PULL LOCOMOTIVE

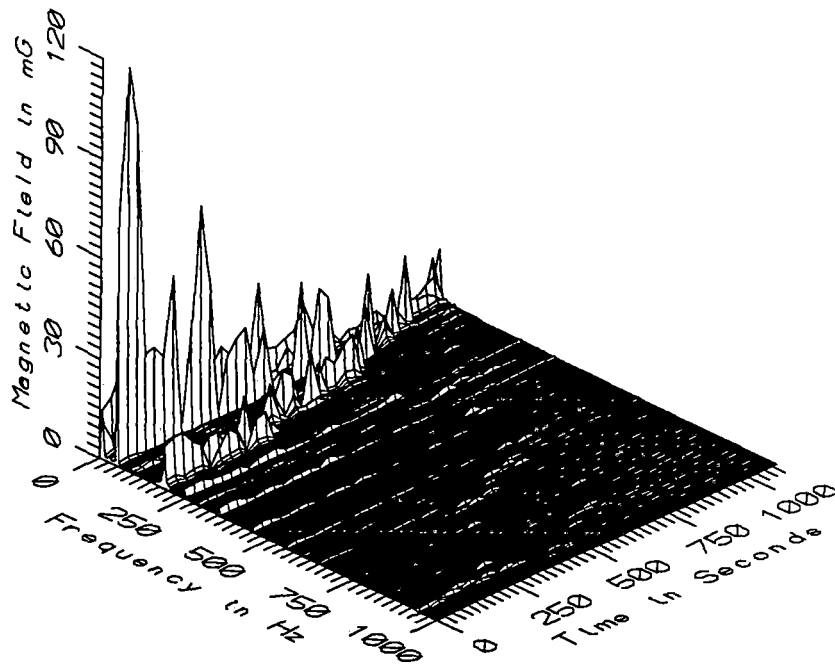

TGV009 - 60cm ABOVE FLOOR AGAINST ENGINEER'S CHAIR, PULL LOCOMOTIVE

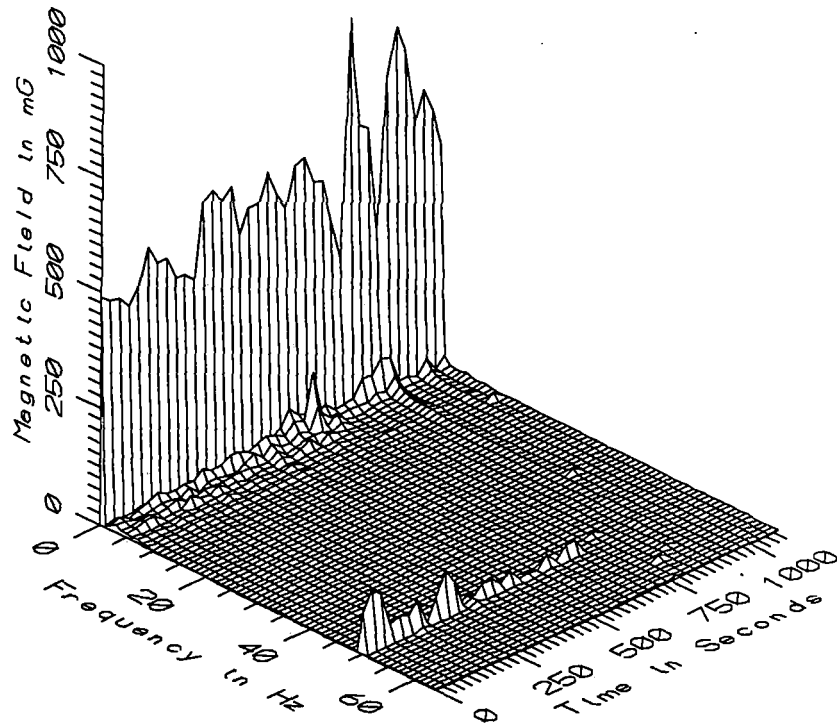

TGV009 - 110cm ABOVE FLOOR AGAINST ENGINEER'S CHAIR, PULL LOCOMOTIVE

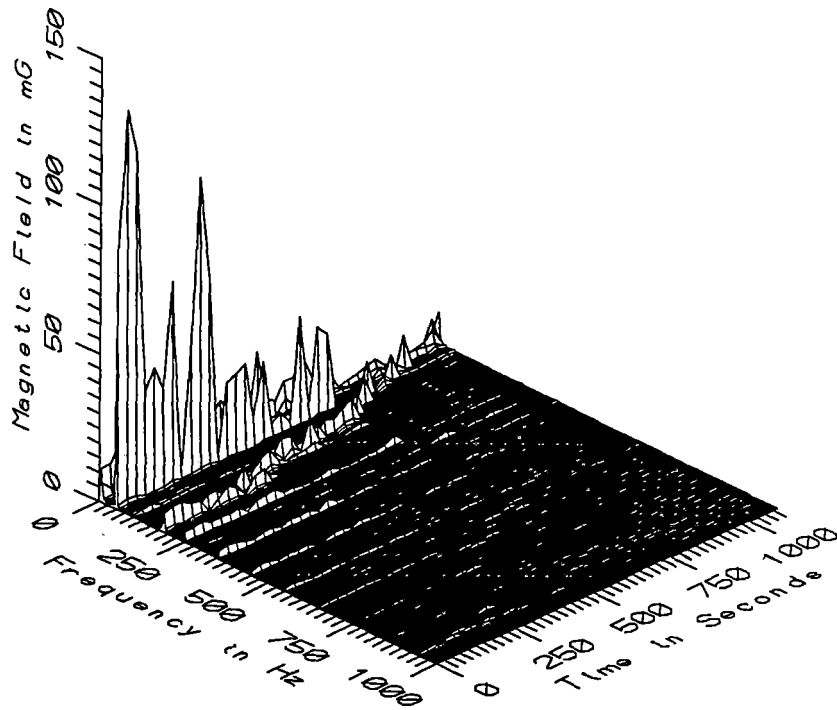

TGV009 - 110cm ABOVE FLOOR AGAINST ENGINEER'S CHAIR, PULL LOCOMOTIVE

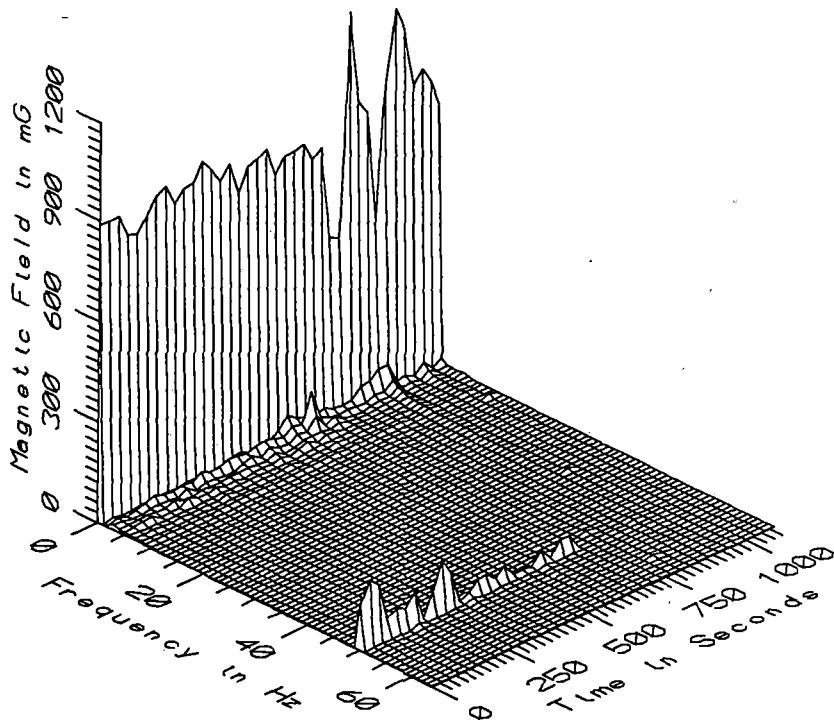

TGV009 - 160cm ABOVE FLOOR AGAINST ENGINEER'S CHAIR, PULL LOCOMOTIVE

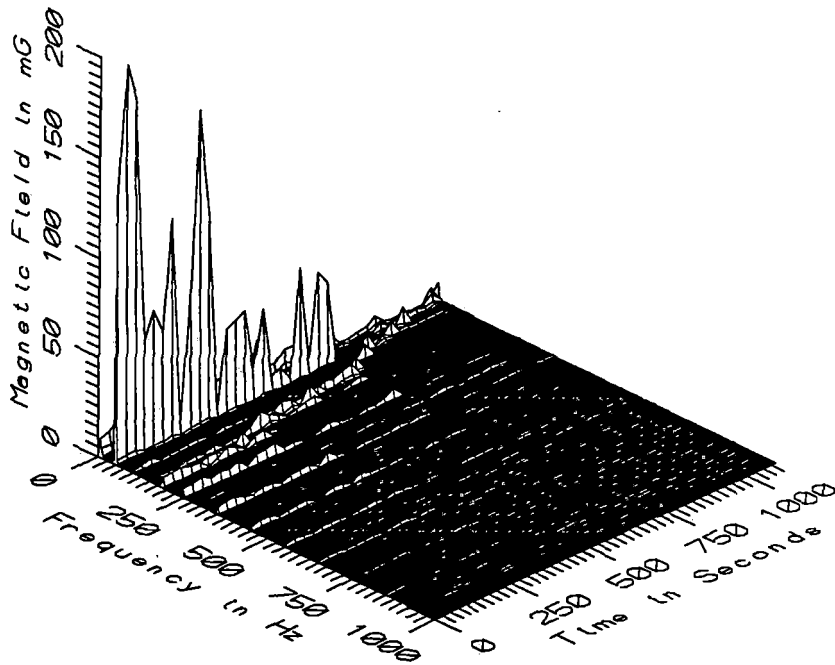

TGV009 - 160cm ABOVE FLOOR AGAINST ENGINEER'S CHAIR, PULL LOCOMOTIVE

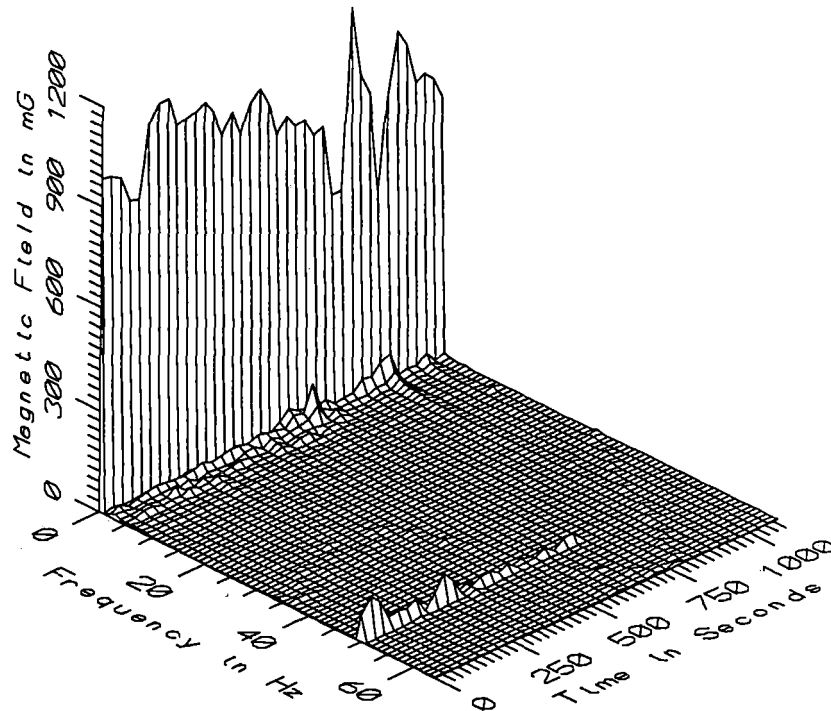

TGV009 - REF. PROBE - ASSISTANT ENGINEER'S CONSOLE, PULL LOCOMOTIVE

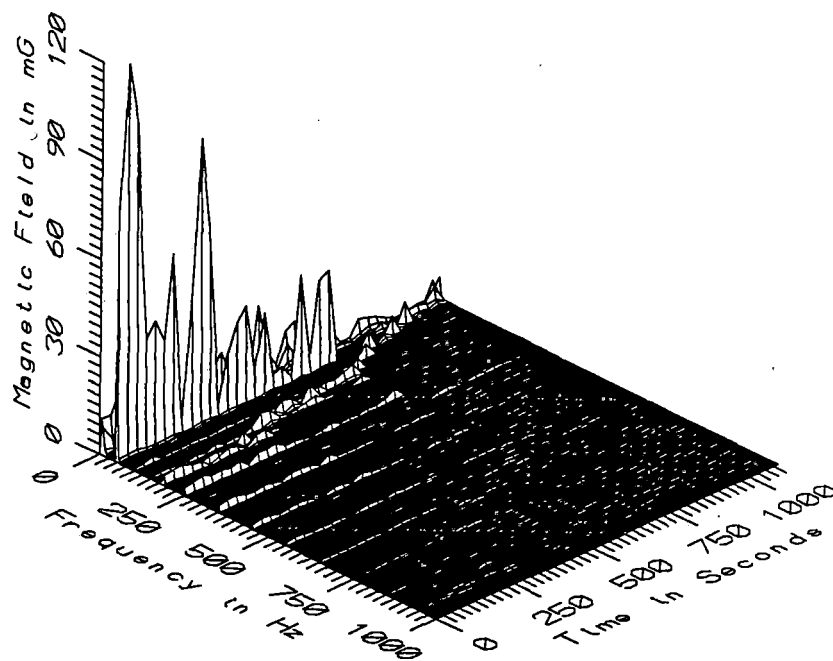

TGV009 - REF. PROBE - ASSISTANT ENGINEER'S CONSOLE, PULL LOCOMOTIVE

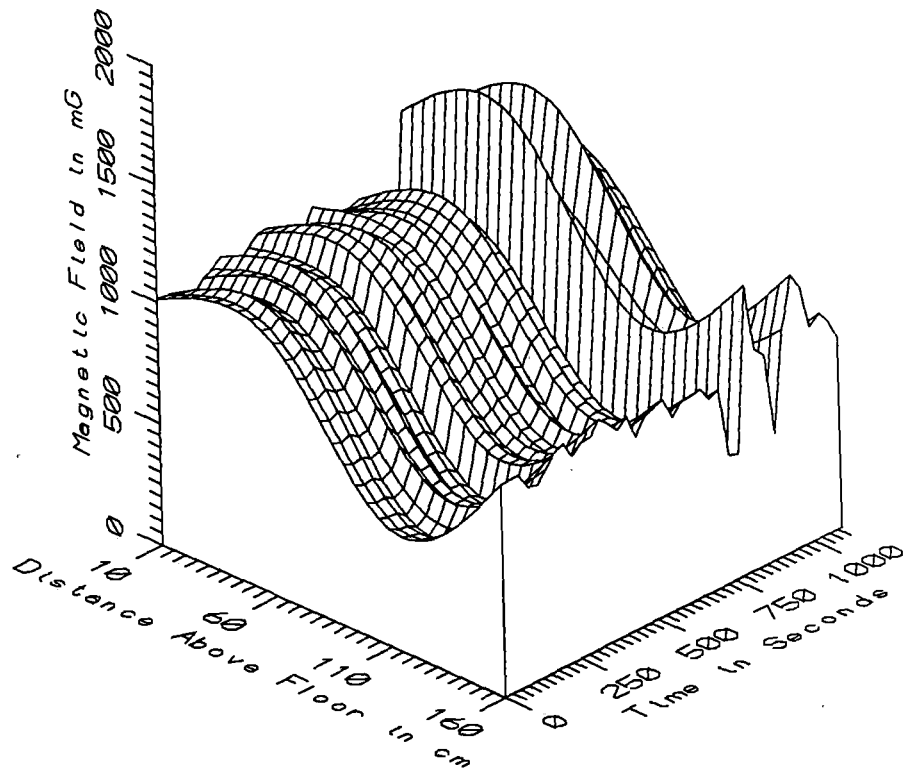

TGV009 - AGAINST ENGINEER'S CHAIR, PULL LOCOMOTIVE - STATIC

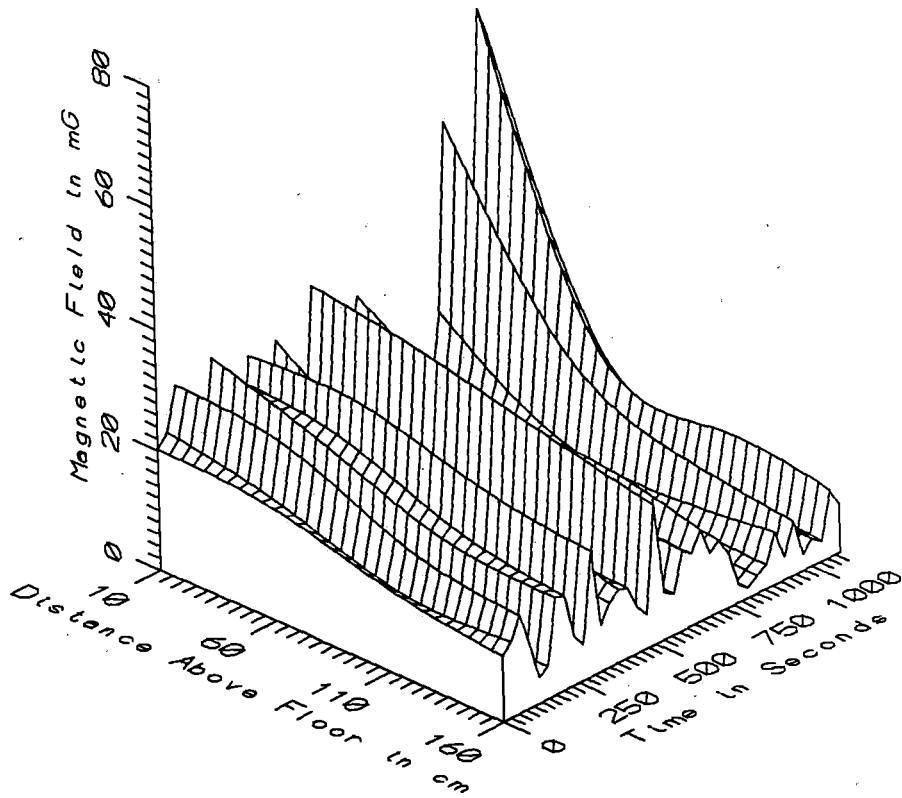

TGV009 - AGAINST ENGINEER'S CHAIR, PULL LOCOMOTIVE - LOW FREQ, 5-45Hz

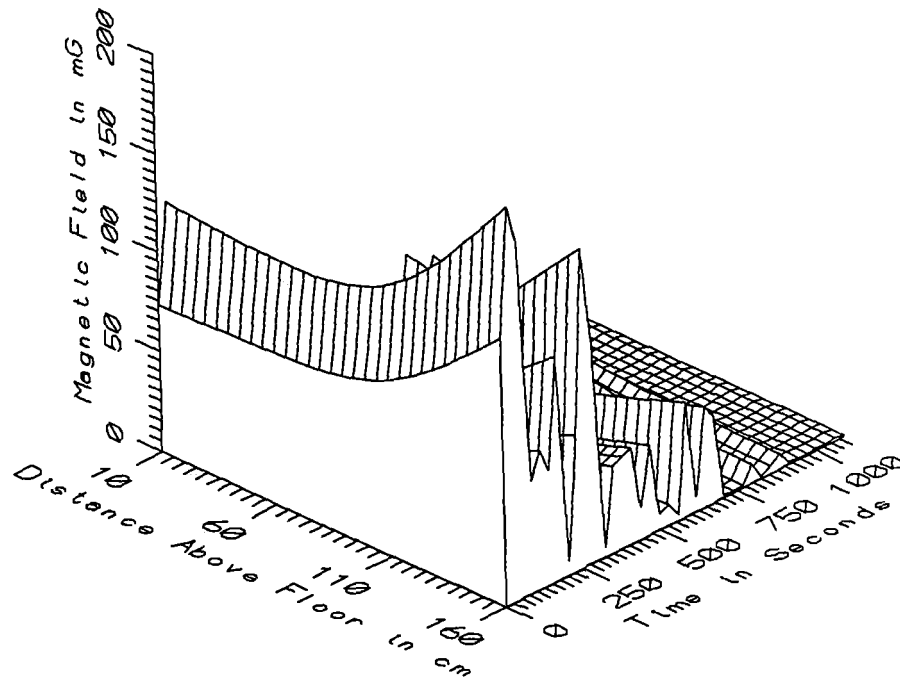

TGV009 - AGAINST ENGINEER'S CHAIR, PULL LOCOMOTIVE - POWER FREQ, 50-60Hz

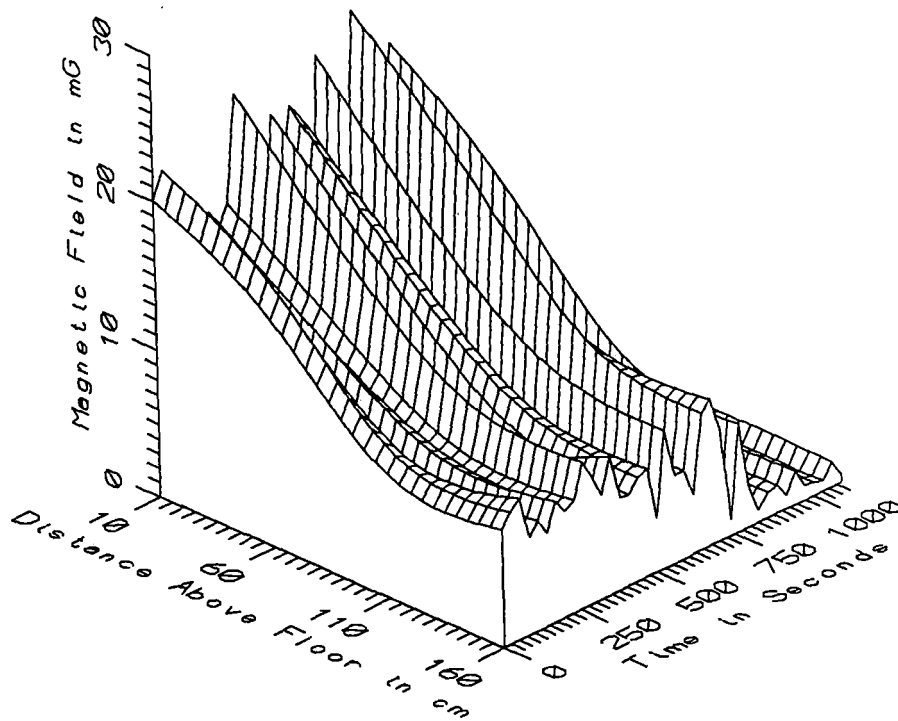

TGV009 - AGAINST ENGINEER'S CHAIR, PULL LOCOMOTIVE - POWER HARM, 65-300Hz

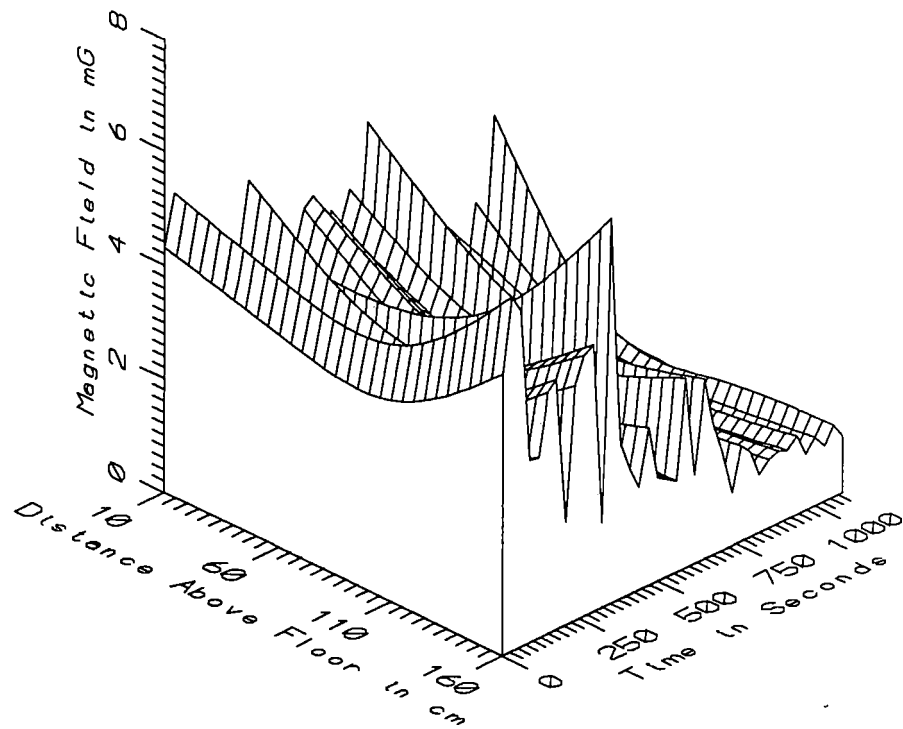

TGV009 - AGAINST ENGINEER'S CHAIR, PULL LOCOMOTIVE - HIGH FREQ, 305-2560Hz

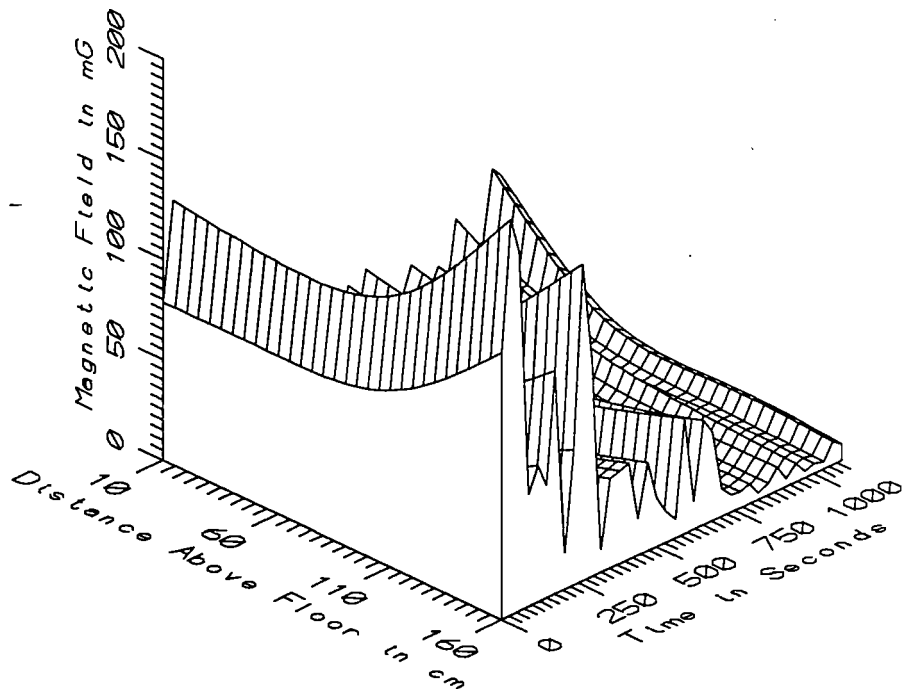

TGV009 - AGAINST ENGINEER'S CHAIR, PULL LOCOMOTIVE - ALL FREQ, 5-2560Hz



TGV009 - ALL SAMPLES		TOTAL OF 38 SAMPLES				
FREQUENCY BAND	HEIGHT ABOVE FLOOR (cm)	MINIMUM MAGNETIC FIELD (mG)	MAXIMUM MAGNETIC FIELD (mG)	AVERAGE MAGNETIC FIELD (mG)	STANDARD DEVIATION (mG)	COEFFICIENT OF VARIATION (%)
STATIC	10	512.93	1292.51	998.79	134.60	13.48
	60	702.99	1476.99	1067.49	144.97	13.58
	110	333.98	855.23	544.08	104.62	19.23
	160	511.98	1188.87	857.30	130.34	15.20
5-45Hz LOW FREQ	10	4.75	65.38	21.41	13.73	64.12
	60	3.19	31.39	13.59	7.18	52.87
	110	2.81	27.30	10.87	5.85	53.82
	160	1.79	23.28	9.41	5.05	53.65
50-60Hz PWR FREQ	10	0.36	123.06	23.96	29.13	121.57
	60	0.46	118.23	21.50	27.89	129.67
	110	0.60	133.34	26.31	34.47	131.01
	160	0.68	198.16	40.75	53.54	131.41
65-300Hz PWR HARM	10	0.56	26.18	13.55	8.15	60.16
	60	0.58	18.56	9.29	5.83	62.75
	110	0.47	10.93	5.87	3.42	58.32
	160	0.54	10.08	5.66	3.26	57.64
305-2560Hz HIGH FREQ	10	0.65	5.18	2.96	1.19	40.20
	60	0.71	4.51	2.22	0.96	43.46
	110	0.70	4.42	2.00	1.03	51.62
	160	0.92	6.75	2.56	1.63	63.57
5-2560Hz ALL FREQ	10	6.99	127.07	41.08	25.09	61.09
	60	4.28	120.91	30.66	25.63	83.59
	110	3.86	134.35	32.12	32.36	100.74
	160	3.29	198.88	45.03	51.57	114.53

TGV009 - AC SECTION ONLY			TOTAL OF 24 SAMPLES			
FREQUENCY BAND	HEIGHT ABOVE FLOOR (cm)	MINIMUM MAGNETIC FIELD (mG)	MAXIMUM MAGNETIC FIELD (mG)	AVERAGE MAGNETIC FIELD (mG)	STANDARD DEVIATION (mG)	COEFFICIENT OF VARIATION (%)
STATIC	10	926.11	1080.08	1007.31	40.15	3.99
	60	972.44	1149.41	1053.08	50.47	4.79
	110	433.55	608.93	521.96	56.23	10.77
	160	792.18	939.28	861.98	39.70	4.61
5-45Hz LOW FREQ	10	8.13	33.98	19.64	7.22	36.78
	60	6.12	31.39	16.03	6.99	43.60
	110	5.18	27.30	13.17	5.62	42.67
	160	4.54	23.28	11.38	4.84	42.52
50-60Hz PWR FREQ	10	2.49	123.06	33.48	32.13	95.95
	60	1.91	118.23	31.53	30.66	97.25
	110	2.22	133.34	40.16	36.89	91.87
	160	2.89	198.16	63.18	56.41	89.29
65-300Hz PWR HARM	10	2.04	26.18	17.81	5.30	29.73
	60	2.70	18.56	12.42	3.54	28.54
	110	3.18	10.93	7.85	1.79	22.84
	160	3.74	10.08	7.64	1.74	22.72
305-2560Hz HIGH FREQ	10	1.33	5.18	3.55	0.86	24.10
	60	1.51	4.51	2.73	0.73	26.85
	110	1.38	4.42	2.55	0.90	35.20
	160	1.49	6.75	3.34	1.58	47.41
5-2560Hz ALL FREQ	10	20.05	127.07	46.71	27.44	58.74
	60	15.52	120.91	40.67	27.38	67.33
	110	11.11	134.35	45.67	33.99	74.42
	160	9.76	198.88	66.76	54.16	81.12

TGV009 - TRANSITION BETWEEN AC AND DC SECTIONS					TOTAL OF 7 SAMPLES	
FREQUENCY BAND	HEIGHT ABOVE FLOOR (cm)	MINIMUM MAGNETIC FIELD (mG)	MAXIMUM MAGNETIC FIELD (mG)	AVERAGE MAGNETIC FIELD (mG)	STANDARD DEVIATION (mG)	COEFFICIENT OF VARIATION (%)
STATIC	10	512.93	1292.51	910.04	279.70	30.73
	60	702.99	1476.99	1004.26	282.34	28.11
	110	333.98	855.23	529.12	179.49	33.92
	160	511.98	1188.87	760.46	255.55	33.60
5-45Hz LOW FREQ	10	4.75	13.29	8.51	2.84	33.34
	60	3.19	13.95	6.57	3.60	54.87
	110	2.81	13.85	6.09	3.90	64.03
	160	1.79	11.97	5.94	3.90	65.66
50-60Hz PWR FREQ	10	0.36	36.40	12.29	15.36	124.93
	60	0.46	23.45	7.33	8.93	121.79
	110	0.60	11.56	4.14	4.44	107.39
	160	0.73	9.42	3.59	3.61	100.51
65-300Hz PWR HARM	10	0.56	22.75	8.71	9.20	105.59
	60	0.76	16.47	6.25	6.49	103.72
	110	0.75	9.06	3.76	3.55	94.44
	160	0.84	7.72	3.38	2.94	87.06
305-2560Hz HIGH FREQ	10	0.65	3.27	2.07	1.06	51.06
	60	0.71	2.55	1.65	0.72	43.56
	110	0.70	1.76	1.22	0.41	33.77
	160	0.92	1.69	1.32	0.31	23.29
5-2560Hz ALL FREQ	10	6.99	37.80	22.02	10.88	49.40
	60	4.28	24.56	14.52	7.16	49.31
	110	3.86	16.69	9.80	4.13	42.15
	160	3.45	14.39	9.05	3.61	39.92

TGV009 - DC SECTION ONLY		TOTAL OF 7 SAMPLES				
FREQUENCY BAND	HEIGHT ABOVE FLOOR (cm)	MINIMUM MAGNETIC FIELD (mG)	MAXIMUM MAGNETIC FIELD (mG)	AVERAGE MAGNETIC FIELD (mG)	STANDARD DEVIATION (mG)	COEFFICIENT OF VARIATION (%)
STATIC	10	885.35	1214.93	1058.33	117.01	11.06
	60	1004.89	1415.06	1180.16	140.72	11.92
	110	485.38	790.27	634.88	106.41	16.76
	160	780.19	1135.77	938.09	121.57	12.96
5-45Hz LOW FREQ	10	19.07	65.38	40.39	18.10	44.81
	60	6.28	21.17	12.22	5.86	47.96
	110	3.63	13.13	7.75	3.93	50.72
	160	2.87	11.19	6.15	3.23	52.50
50-60Hz PWR FREQ	10	1.06	5.79	2.96	1.52	51.44
	60	0.85	2.21	1.31	0.46	34.80
	110	0.61	1.65	0.99	0.33	33.87
	160	0.68	1.64	1.00	0.31	30.83
65-300Hz PWR HARM	10	0.69	8.10	3.75	2.35	62.68
	60	0.58	2.86	1.60	0.71	44.27
	110	0.47	2.19	1.16	0.60	52.01
	160	0.54	2.34	1.18	0.62	52.86
305-2560Hz HIGH FREQ	10	0.89	3.86	1.84	1.01	55.16
	60	0.85	1.19	1.01	0.15	14.45
	110	0.75	1.09	0.91	0.15	16.54
	160	0.97	1.37	1.14	0.16	13.85
5-2560Hz ALL FREQ	10	19.66	66.25	40.80	18.10	44.35
	60	6.56	21.44	12.47	5.84	46.81
	110	3.88	13.40	7.98	3.92	49.11
	160	3.29	11.50	6.49	3.20	49.33

APPENDIX K

DATASET TGV010  
TGV CONTROL CENTER IN MONTPARNASSE STATION

Measurement Setup Code:      Staff: 10      Reference: 12  
   Drawing: A-3

Vehicle Status:                      Not Applicable

Measurement Date:                      September 8, 1992

Measurement Time:                      Start:      10:49:45  
   End:      10:51:20

Number of Samples:                      10

Programmed Sample Interval:      10 sec

Actual Sample Interval:              10.5 sec

Frequency Spectrum Parameters

<u>Probe Type:</u>	<u>Wideband</u>	<u>Static</u>
Maximum Frequency (Hz)	2560	64
Minimum Frequency (Hz)	5	0
Spectral Bandwidth (Hz)	5	1

Missing or Suspect Data:      None

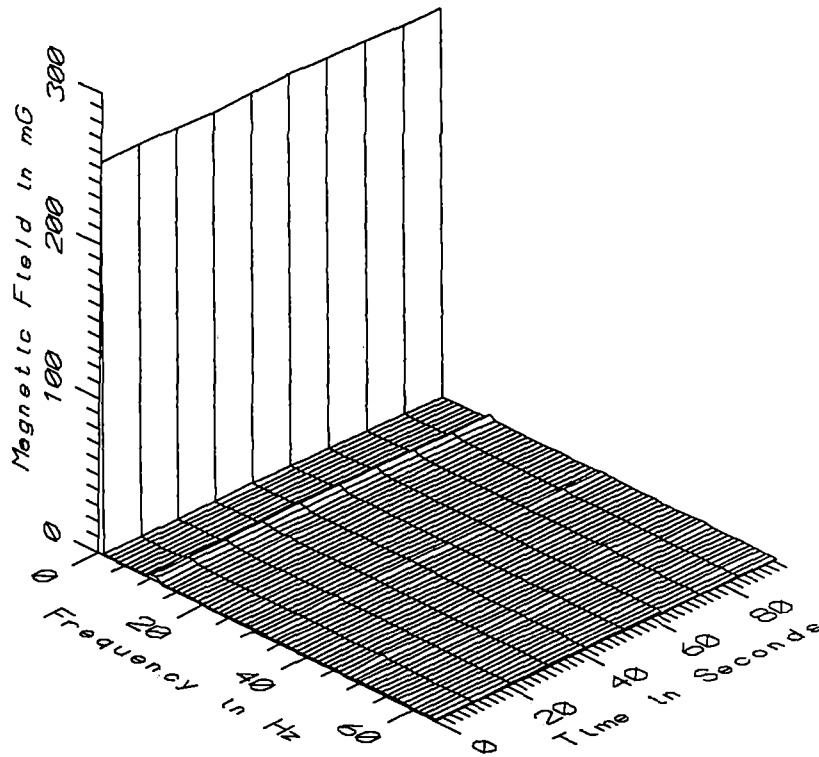

TGV010 - 10cm ABOVE FLOOR NEAR CONSOLE IN TGV CONTROL CENTER

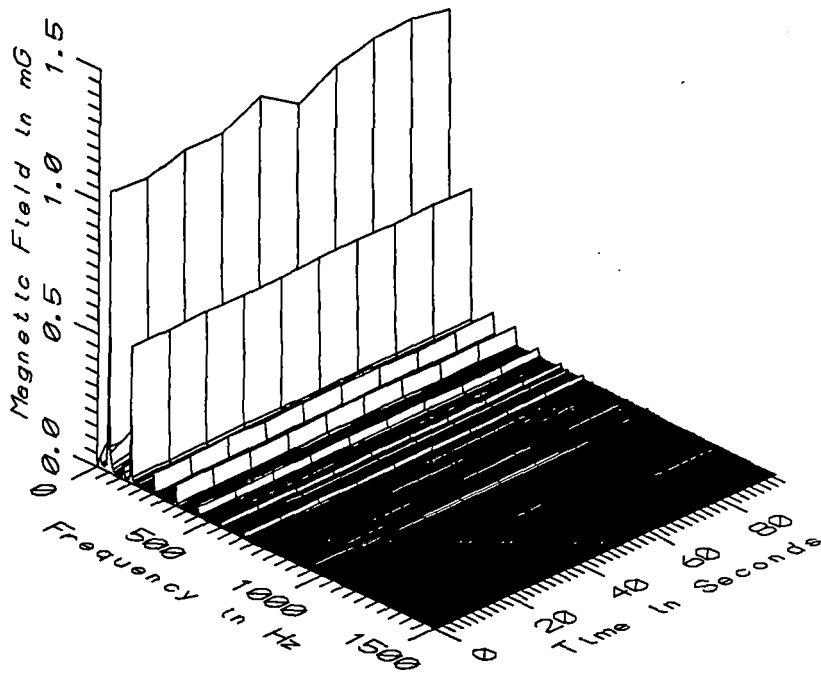

TGV010 - 10cm ABOVE FLOOR NEAR CONSOLE IN TGV CONTROL CENTER

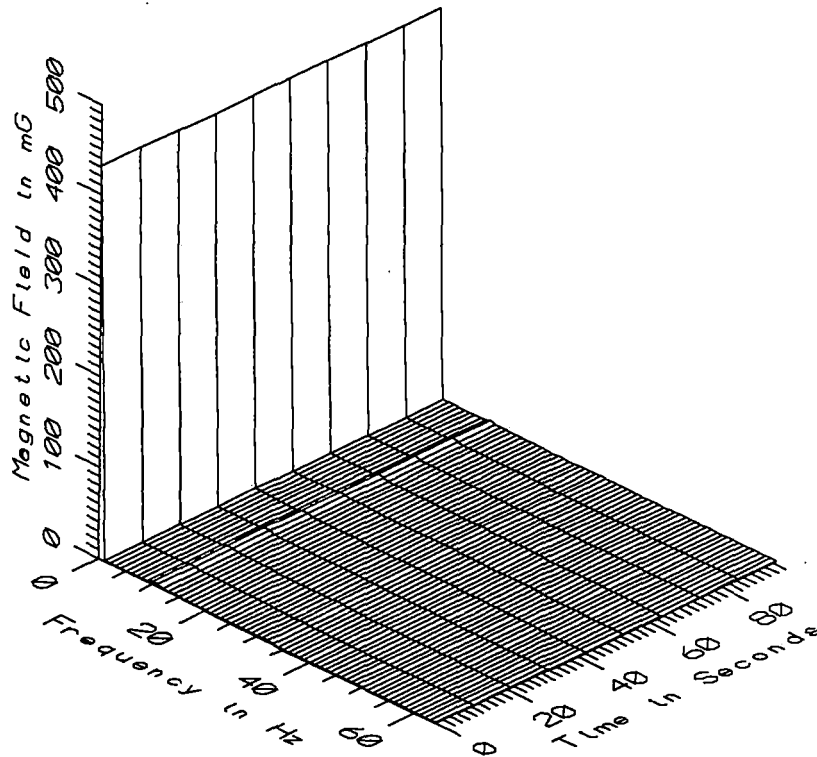

TGV010 - 60cm ABOVE FLOOR NEAR CONSOLE IN TGV CONTROL CENTER

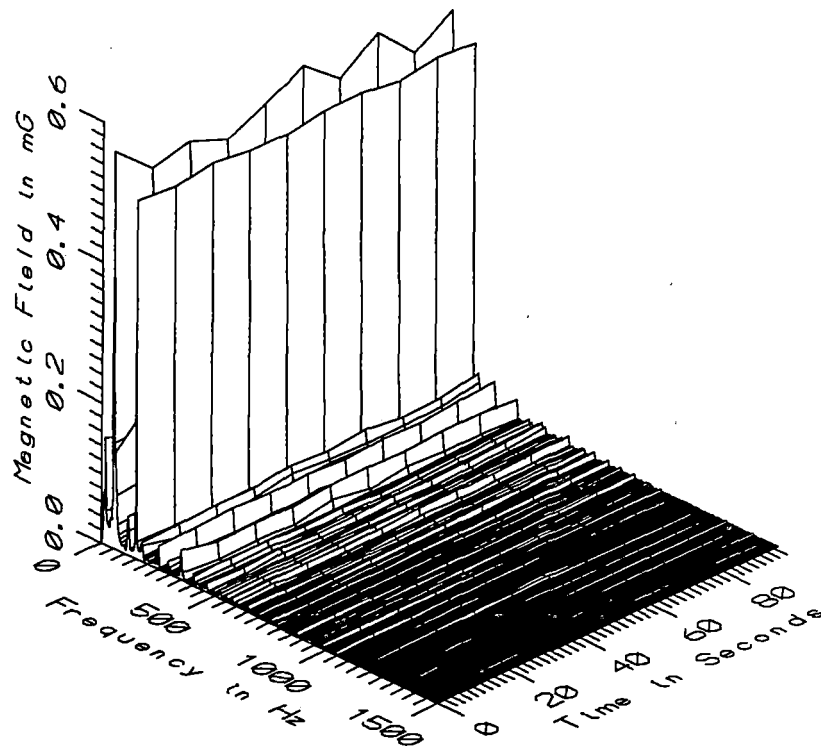

TGV010 - 60cm ABOVE FLOOR NEAR CONSOLE IN TGV CONTROL CENTER

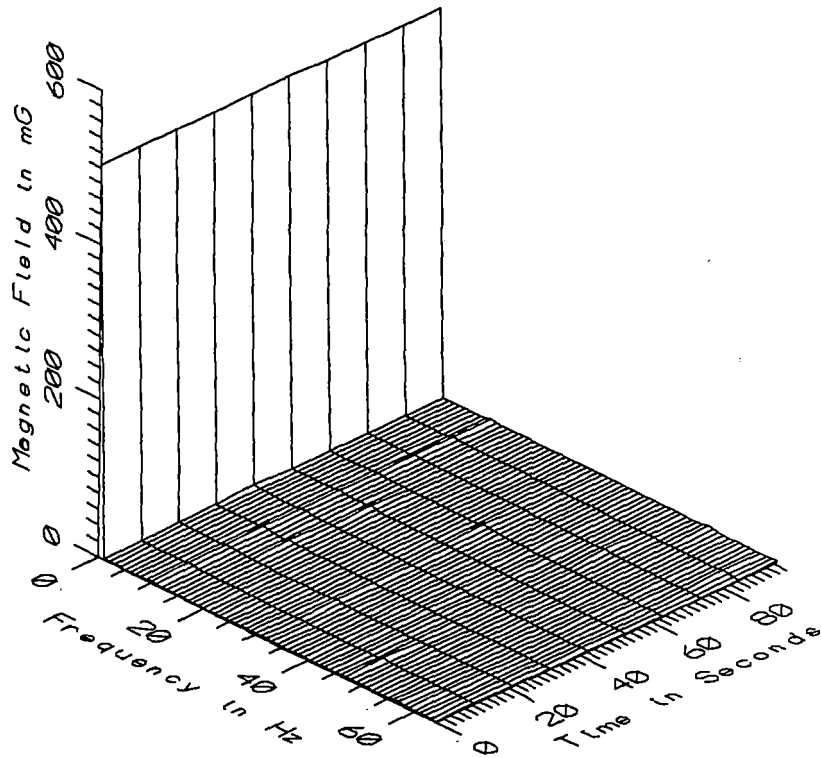

TGV010 - 110cm ABOVE FLOOR NEAR CONSOLE IN TGV CONTROL CENTER

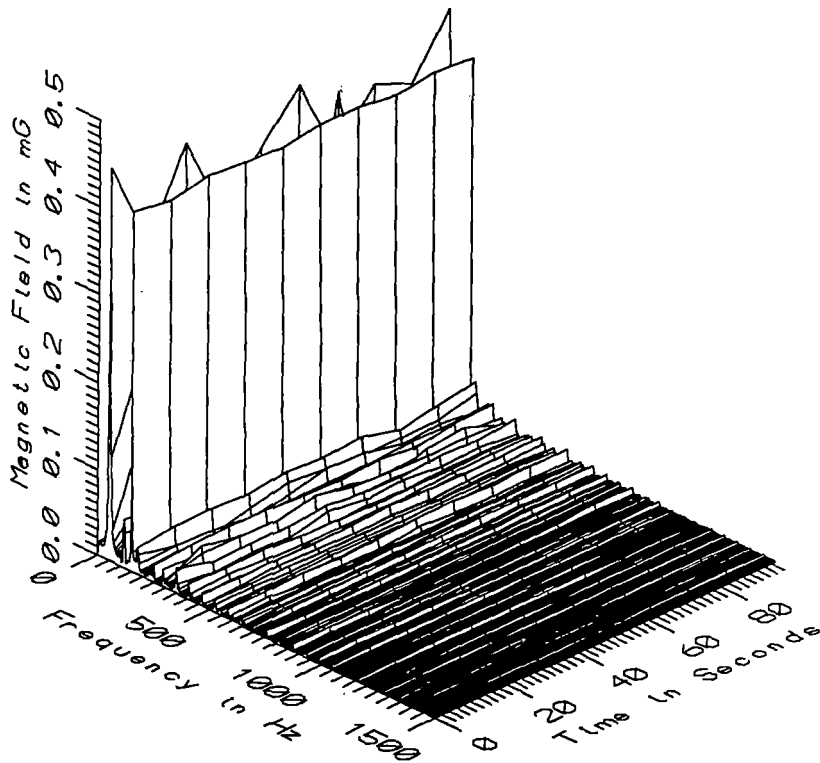

TGV010 - 110cm ABOVE FLOOR NEAR CONSOLE IN TGV CONTROL CENTER



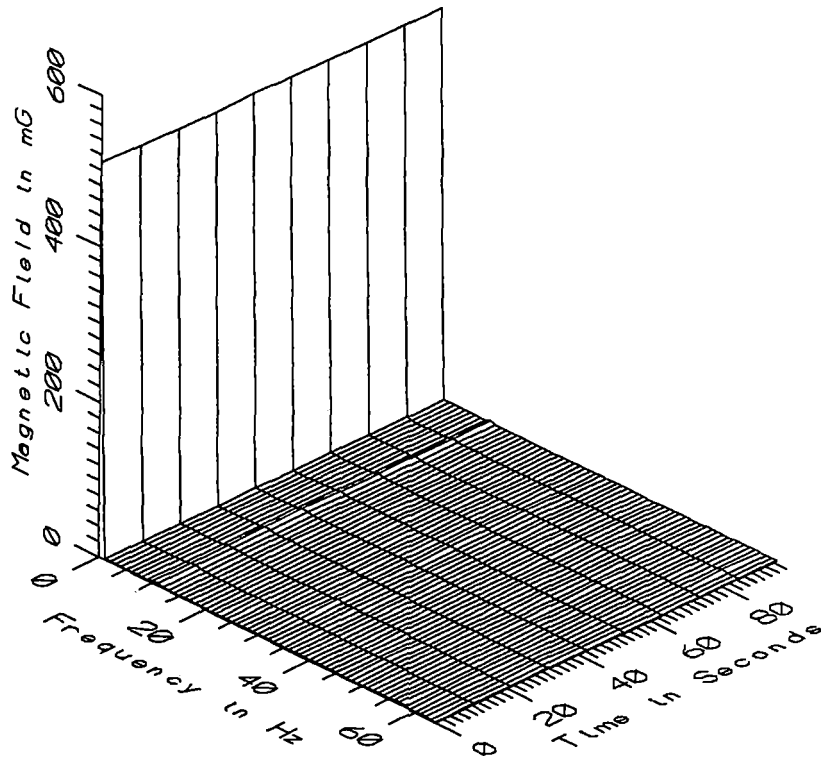

TGV010 - 160cm ABOVE FLOOR NEAR CONSOLE IN TGV CONTROL CENTER

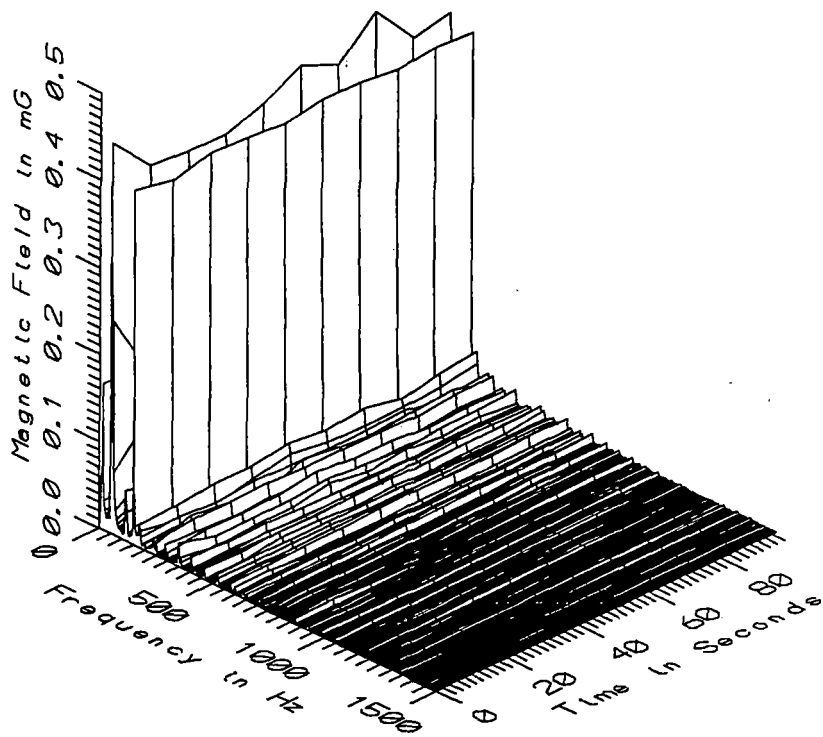

TGV010 - 160cm ABOVE FLOOR NEAR CONSOLE IN TGV CONTROL CENTER

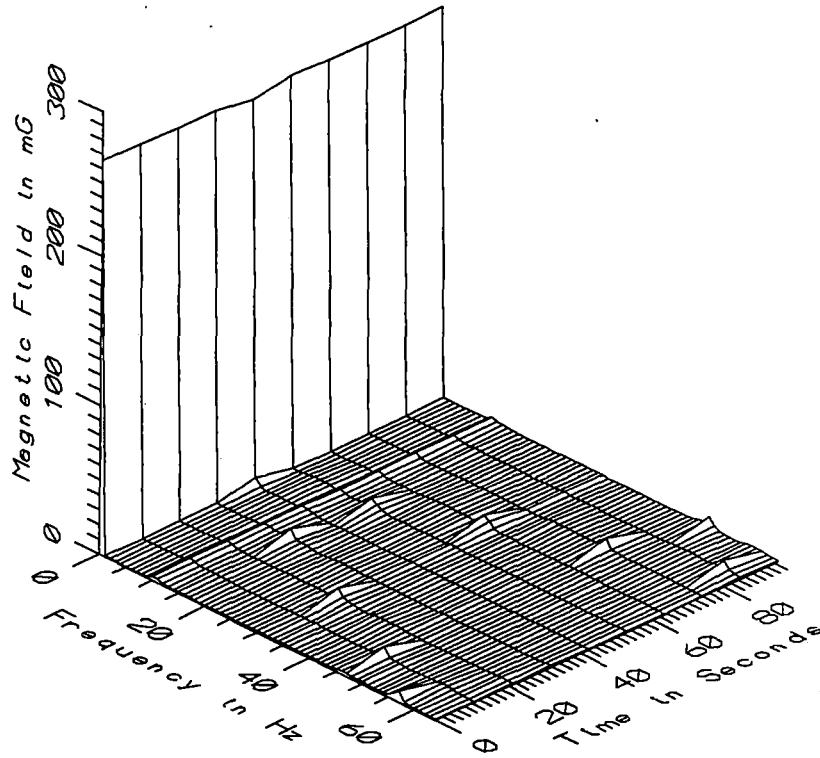

TGV010 - REFERENCE PROBE - ON CHAIR NEAR CONSOLE IN TGV CONTROL CENTER

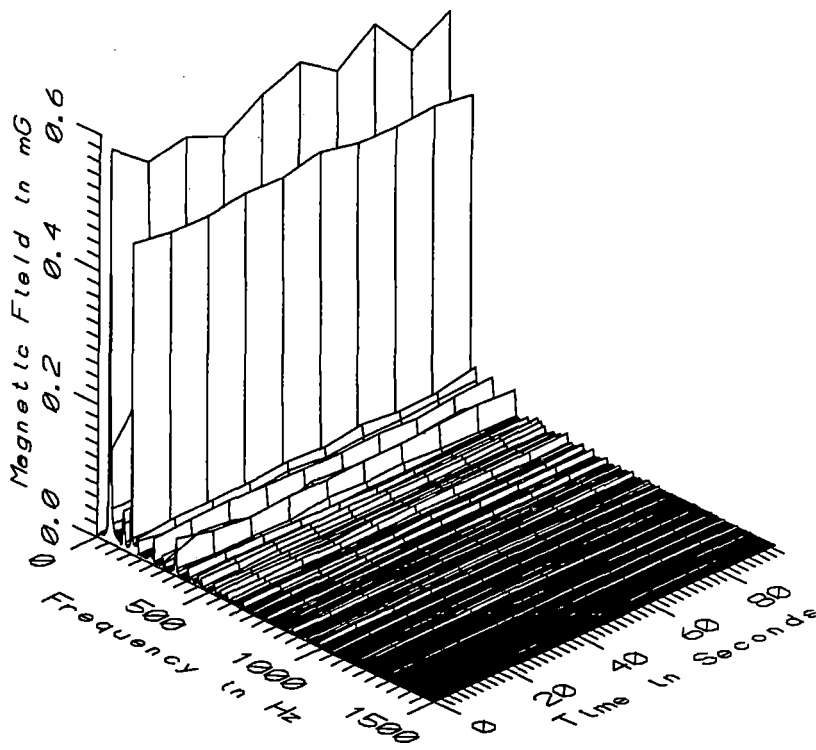

TGV010 - REFERENCE PROBE - ON CHAIR NEAR CONSOLE IN TGV CONTROL CENTER

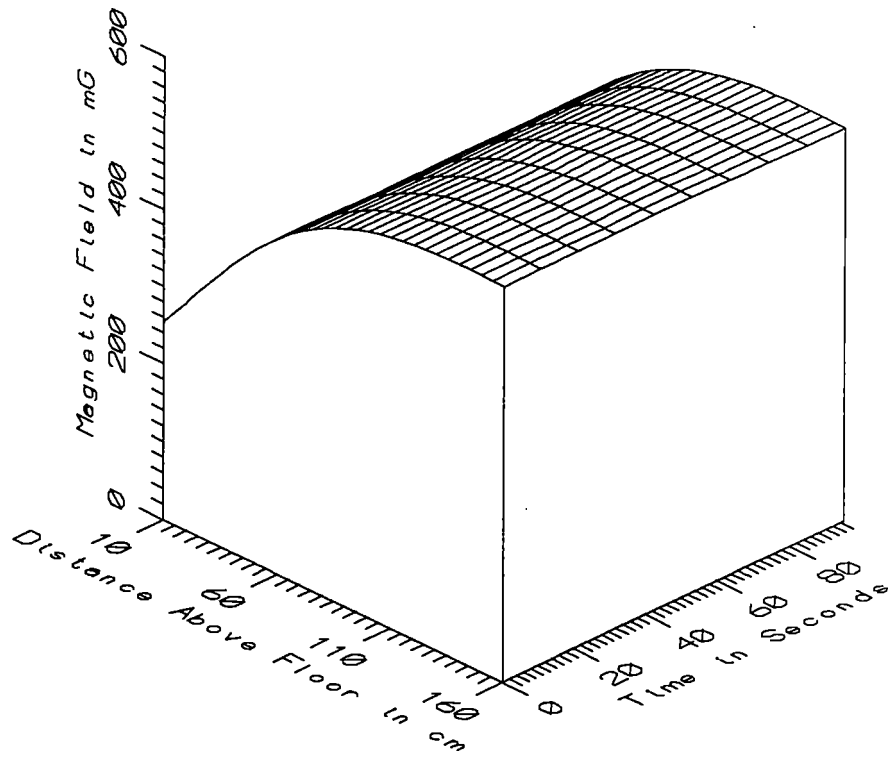

TGV010 - NEAR CONSOLE IN TGV CONTROL CENTER - STATIC

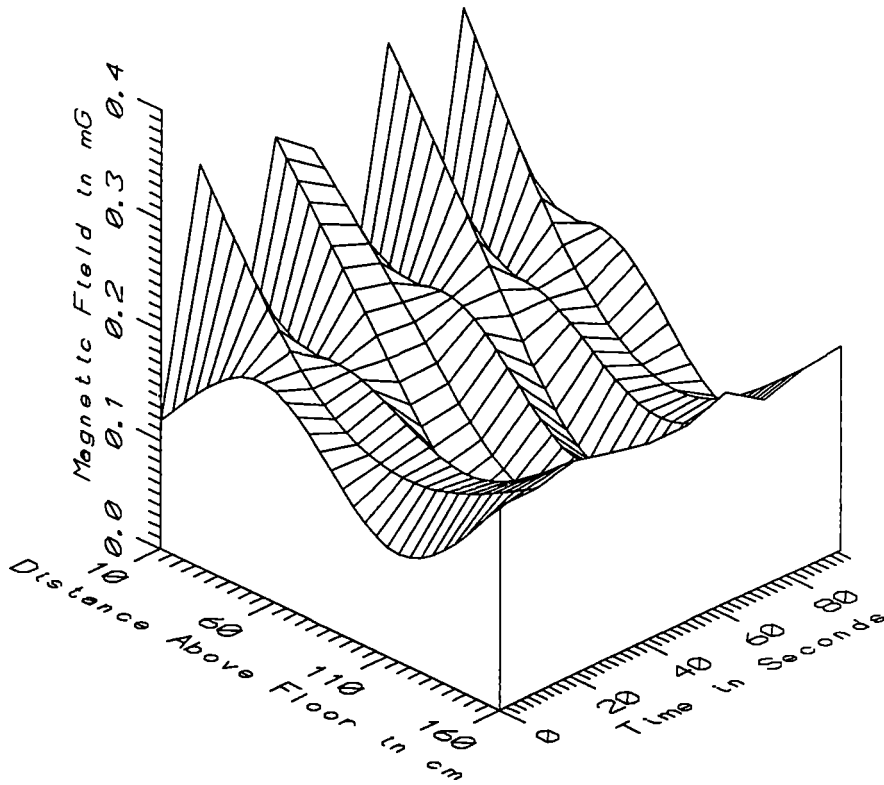

TGV010 - NEAR CONSOLE IN TGV CONTROL CENTER - LOW FREQ, 5-45Hz

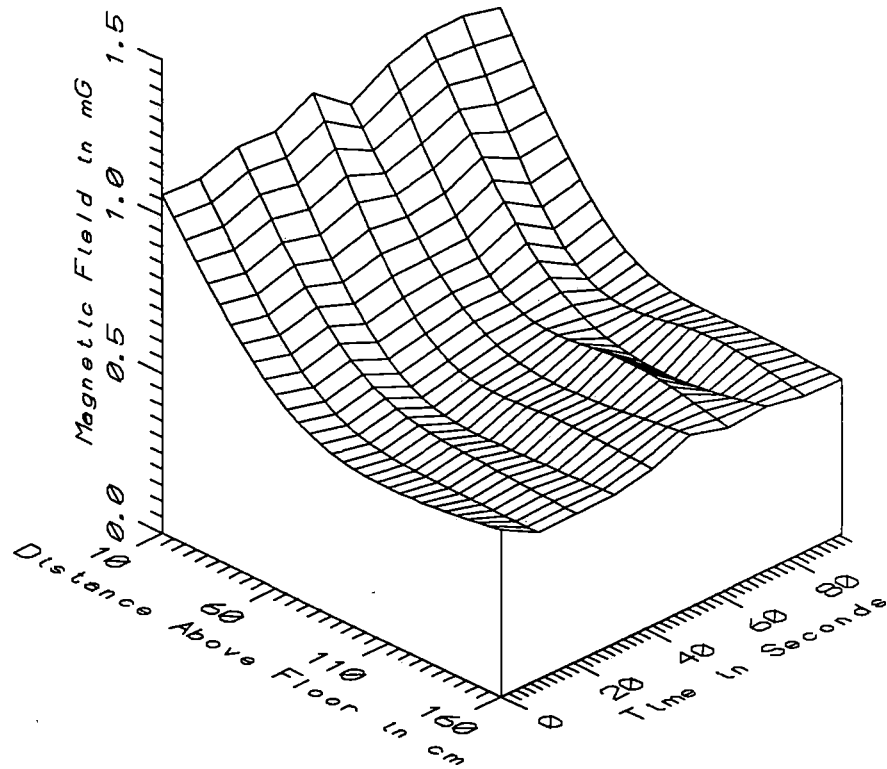

TGV010 - NEAR CONSOLE IN TGV CONTROL CENTER - POWER FREQ, 50-60Hz

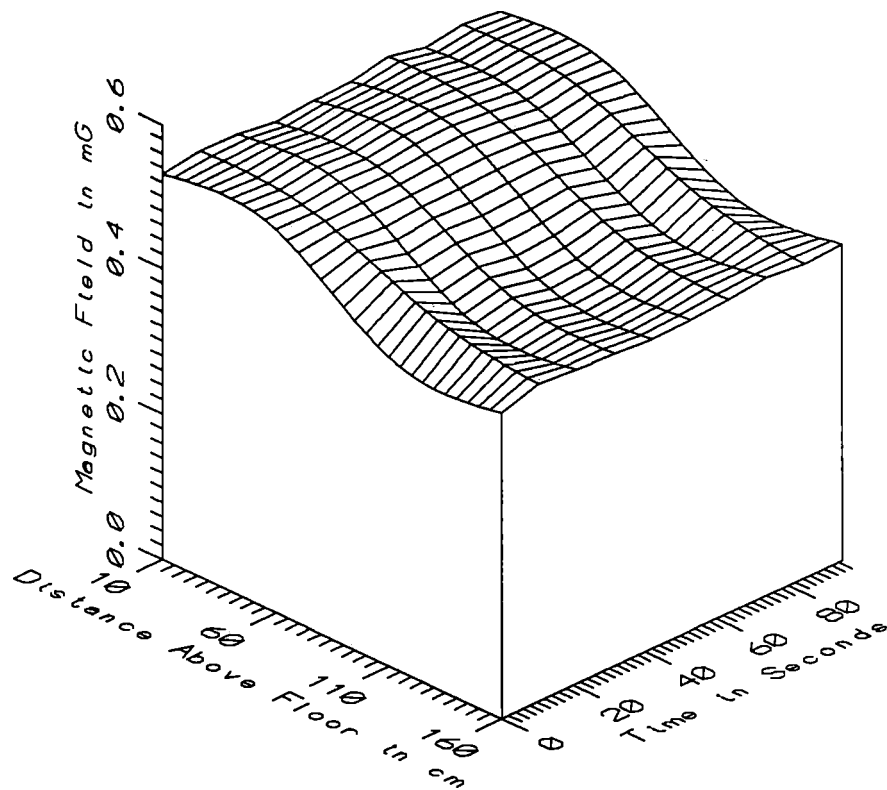

TGV010 - NEAR CONSOLE IN TGV CONTROL CENTER - POWER HARM, 65-300Hz

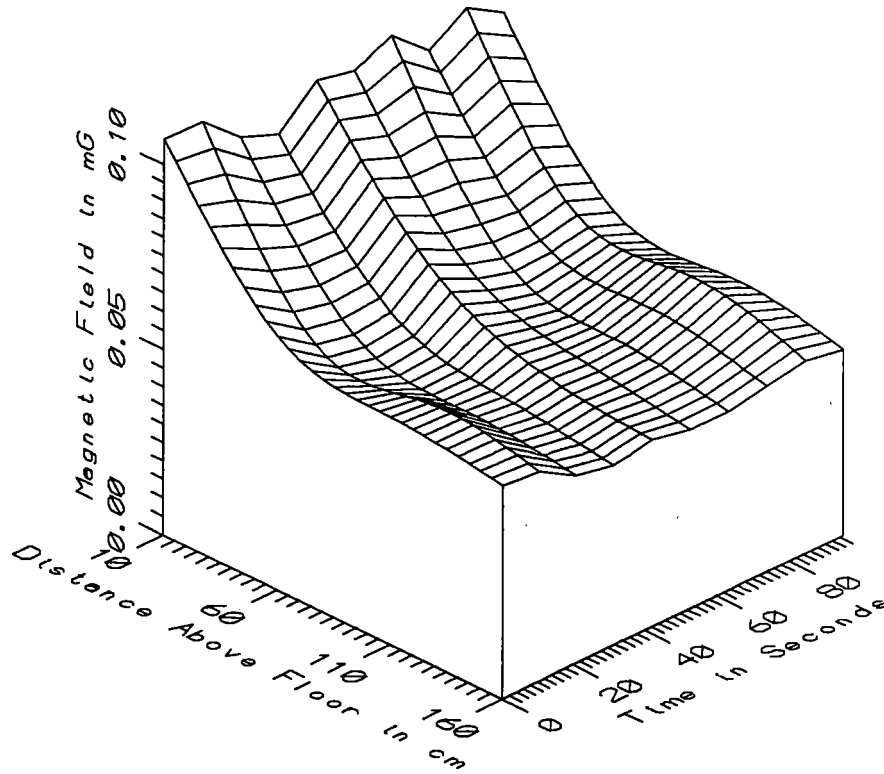

TGV010 - NEAR CONSOLE IN TGV CONTROL CENTER - HIGH FREQ, 305-2560Hz

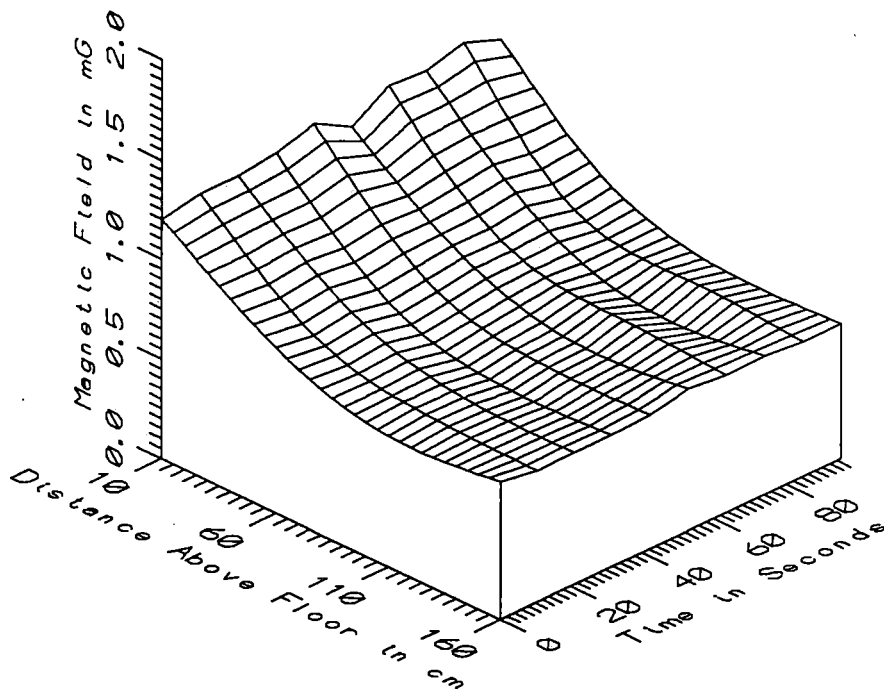

TGV010 - NEAR CONSOLE IN TGV CONTROL CENTER - ALL FREQ, 5-2560Hz

TGV010 - TGV CONTROL CENTER, GARE MONTPARNASSE					TOTAL OF 10 SAMPLES	
FREQUENCY BAND	HEIGHT ABOVE FLOOR (cm)	MINIMUM MAGNETIC FIELD (mG)	MAXIMUM MAGNETIC FIELD (mG)	AVERAGE MAGNETIC FIELD (mG)	STANDARD DEVIATION (mG)	COEFFICIENT OF VARIATION (%)
STATIC	10	253.12	256.00	254.79	0.92	0.36
	60	431.48	433.69	432.64	0.62	0.14
	110	503.57	506.27	504.66	0.78	0.15
	160	509.71	512.14	510.56	0.79	0.16
5-45Hz LOW FREQ	10	0.11	0.36	0.23	0.11	48.27
	60	0.17	0.20	0.18	0.01	4.30
	110	0.07	0.14	0.10	0.03	25.73
	160	0.17	0.20	0.19	0.01	4.02
50-60Hz PWR FREQ	10	1.06	1.19	1.13	0.05	4.52
	60	0.55	0.63	0.59	0.03	4.27
	110	0.45	0.56	0.49	0.03	6.74
	160	0.46	0.54	0.49	0.03	5.57
65-300Hz PWR HARM	10	0.53	0.55	0.54	0.00	0.89
	60	0.52	0.54	0.53	0.00	0.78
	110	0.43	0.47	0.44	0.01	2.90
	160	0.43	0.44	0.43	0.00	1.08
305-2560Hz HIGH FREQ	10	0.09	0.11	0.10	0.00	4.53
	60	0.06	0.07	0.06	0.00	5.67
	110	0.05	0.06	0.06	0.00	6.11
	160	0.05	0.06	0.05	0.00	6.31
5-2560Hz ALL FREQ	10	1.20	1.36	1.28	0.05	4.15
	60	0.78	0.84	0.81	0.02	2.16
	110	0.64	0.72	0.67	0.03	3.98
	160	0.66	0.71	0.68	0.02	2.56

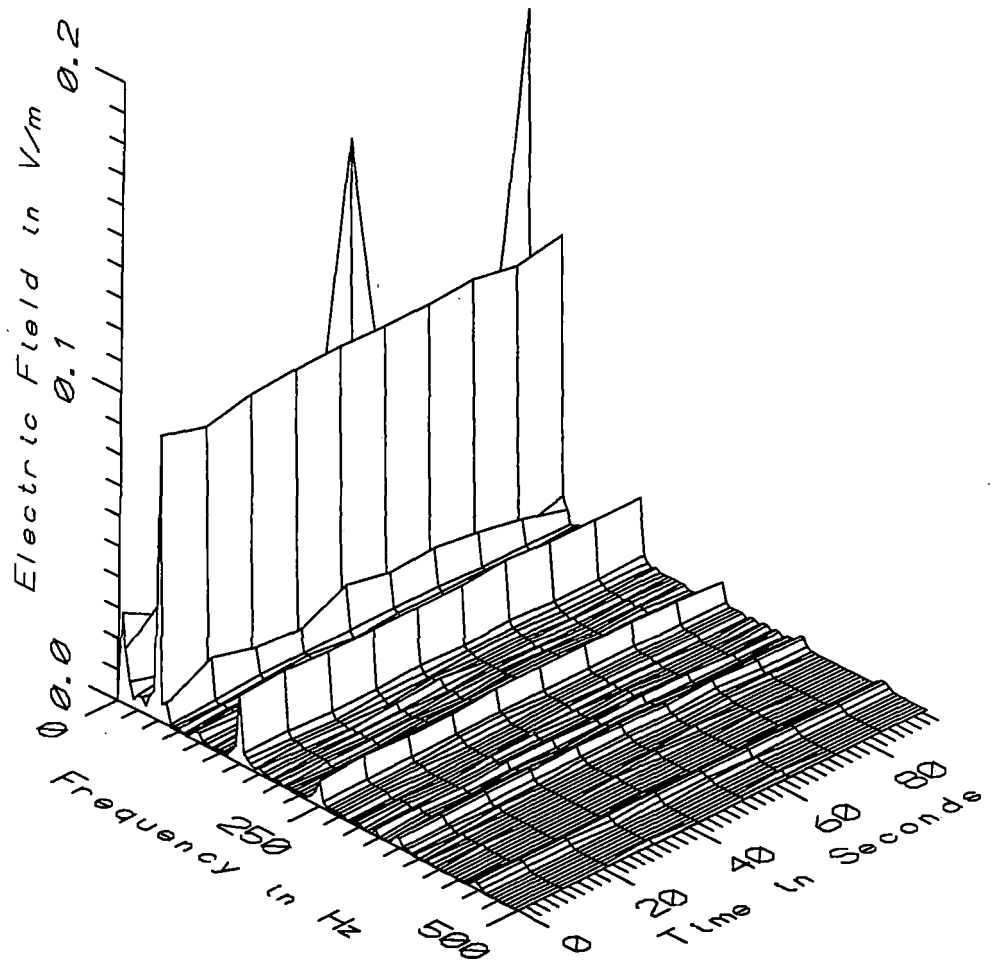

TGV010 - ELECTRIC FIELD IN TGV CONTROL CENTER

APPENDIX L

DATASET TGV011  
HORIZONTAL PROFILE FROM CONSOLE MONITOR  
TGV CONTROL CENTER IN MONTPARNASSE STATION

Measurement Setup Code:           Staff: 11       Reference: 12  
  Drawing: A-3

Vehicle Status:                    Not Applicable

Measurement Date:                 September 8, 1992

Measurement Time:                 Start:       10:51:59  
  End:         10:53:30

Number of Samples:                10

Programmed Sample Interval:       10 sec

Actual Sample Interval:           10.1 sec

Frequency Spectrum Parameters

<u>Probe Type:</u>	<u>Wideband</u>	<u>Static</u>
Maximum Frequency (Hz)	2560	64
Minimum Frequency (Hz)	5	0
Spectral Bandwidth (Hz)	5	1

Missing or Suspect Data:         None



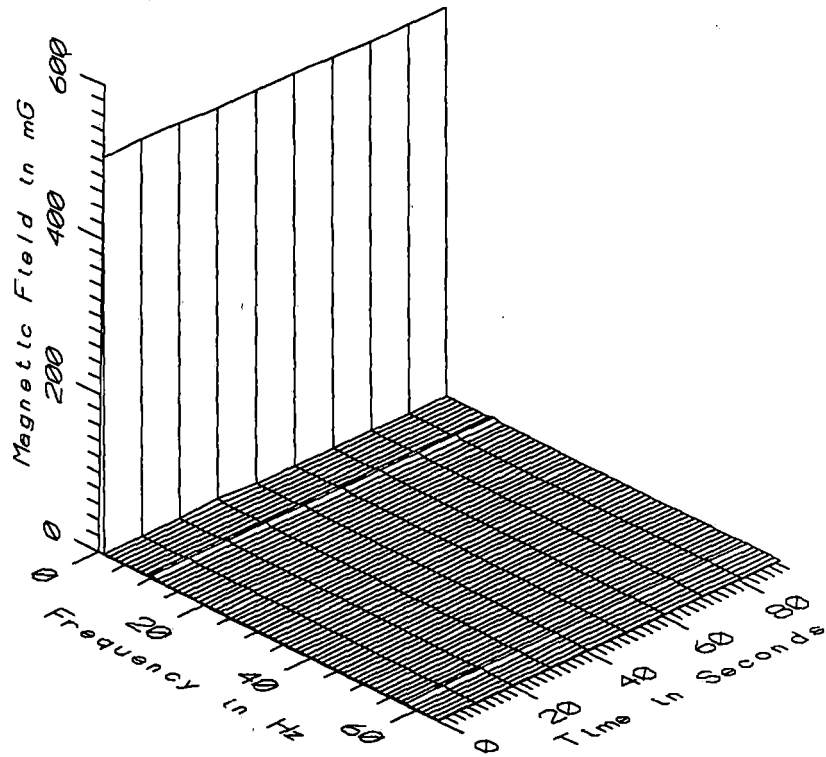

TGV011 - 10cm FROM CENTER OF MONITOR IN TGV CONTROL CENTER

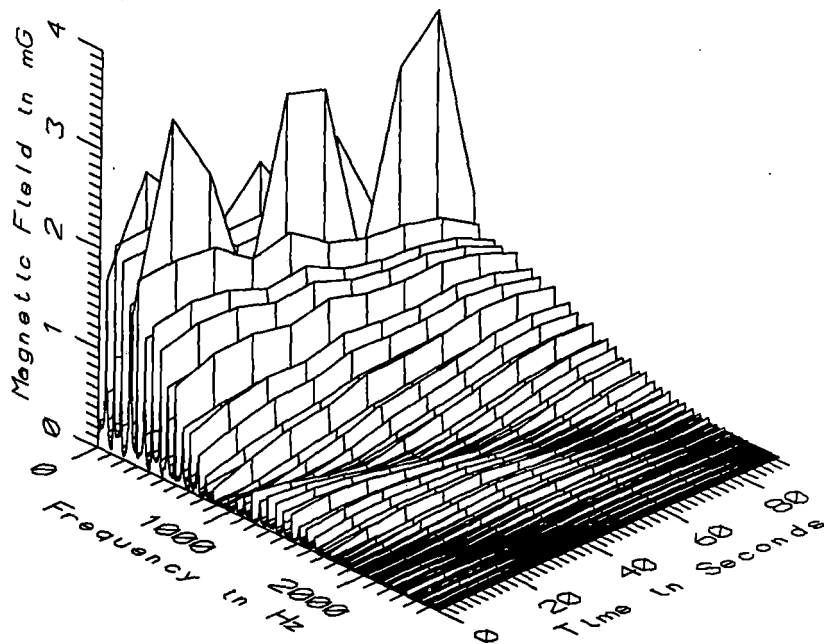

TGV011 - 10cm FROM CENTER OF MONITOR IN TGV CONTROL CENTER

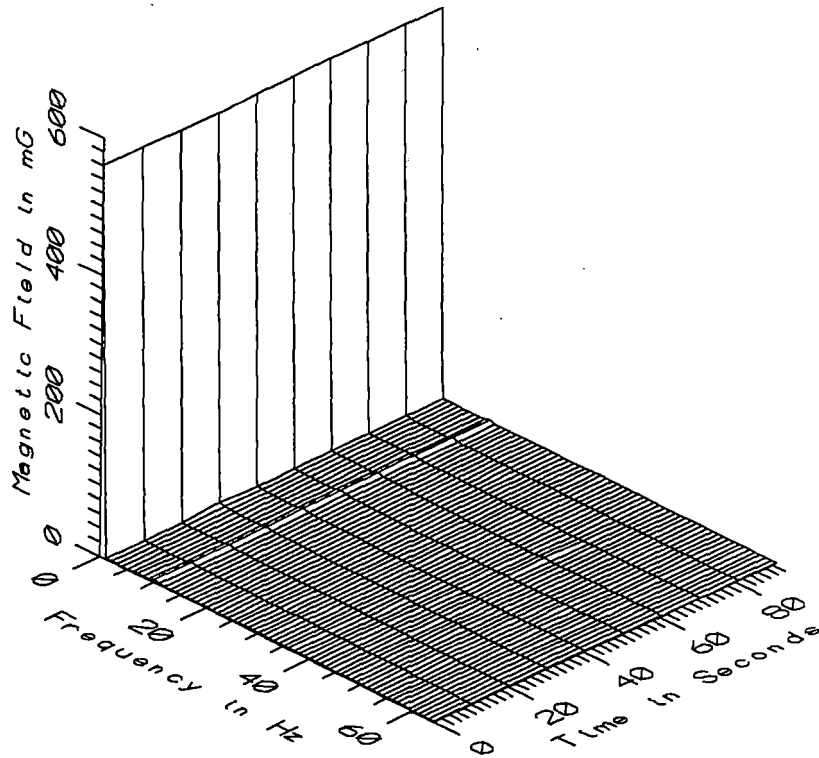

TGV011 - 60cm FROM CENTER OF MONITOR IN TGV CONTROL CENTER

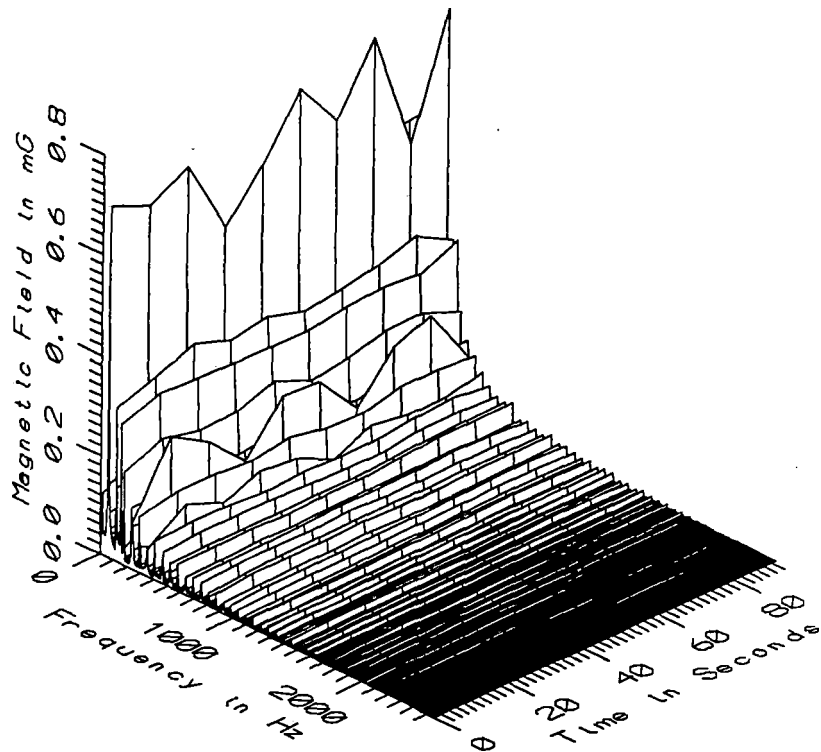

TGV011 - 60cm FROM CENTER OF MONITOR IN TGV CONTROL CENTER

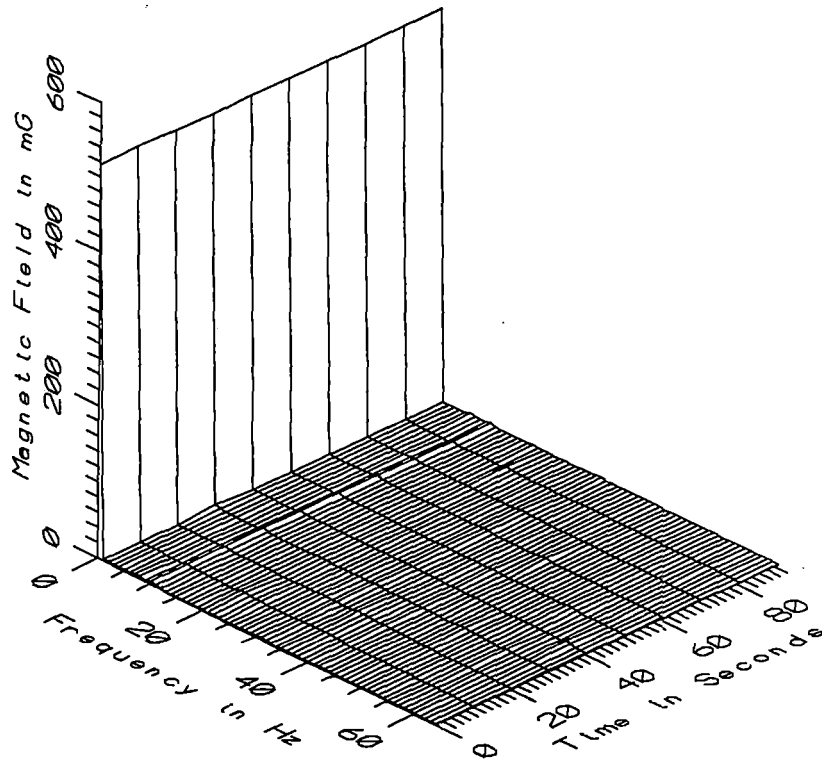

TGV011 - 110cm FROM CENTER OF MONITOR IN TGV CONTROL CENTER

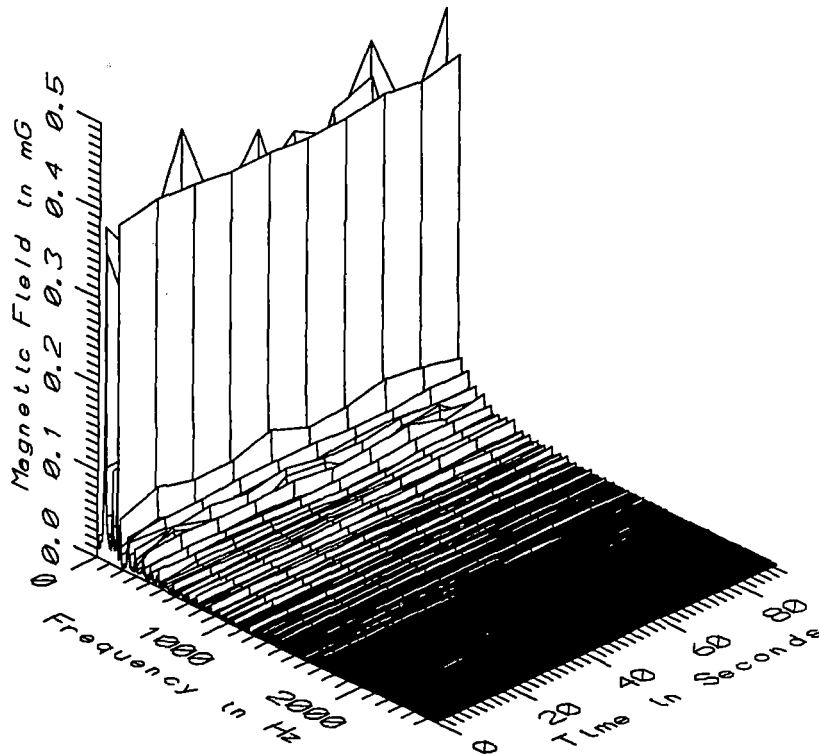

TGV011 - 110cm FROM CENTER OF MONITOR IN TGV CONTROL CENTER

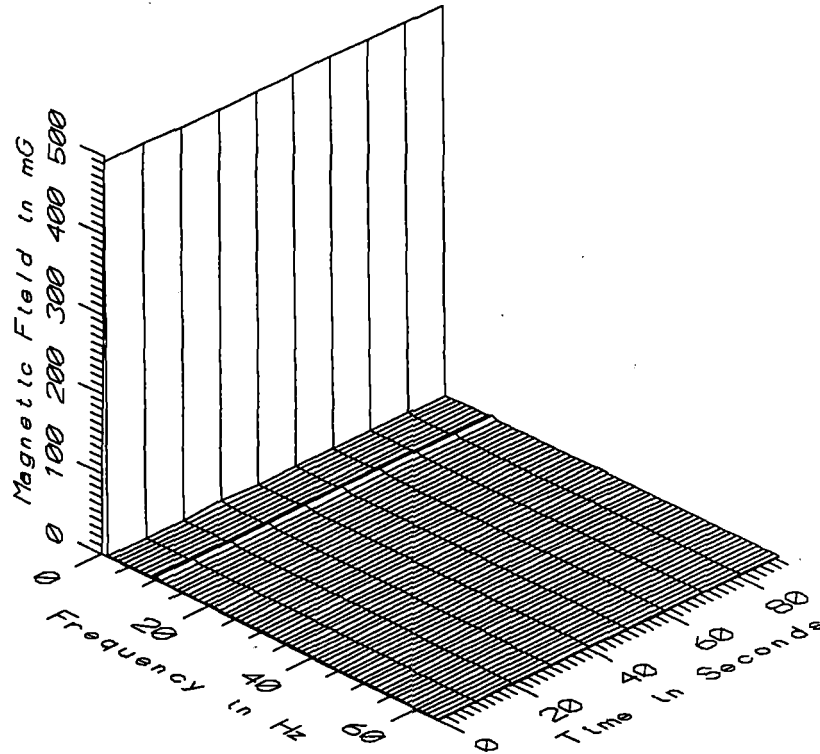

TGV011 - 160cm FROM CENTER OF MONITOR IN TGV CONTROL CENTER

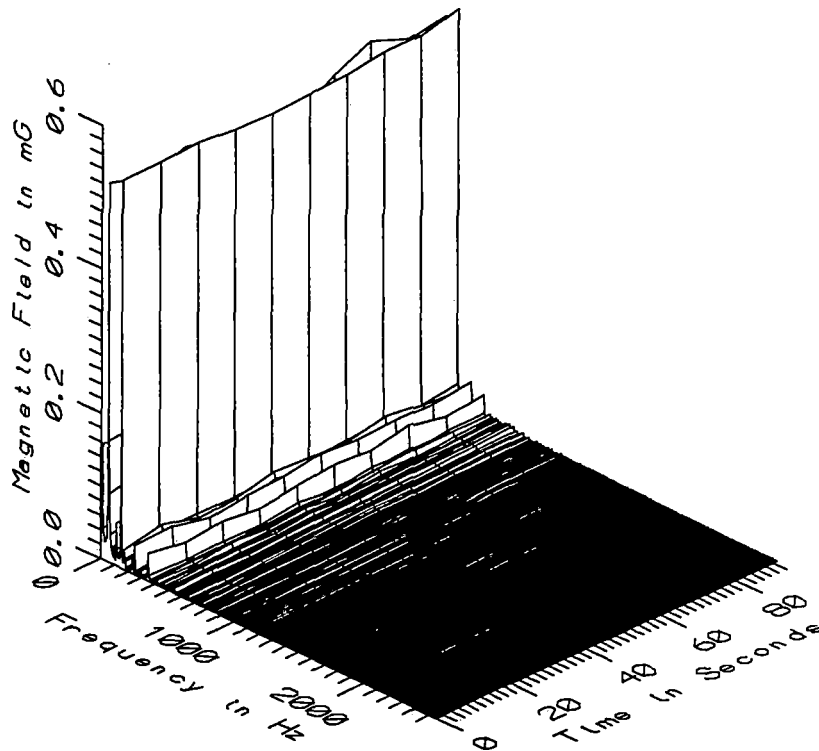

TGV011 - 160cm FROM CENTER OF MONITOR IN TGV CONTROL CENTER

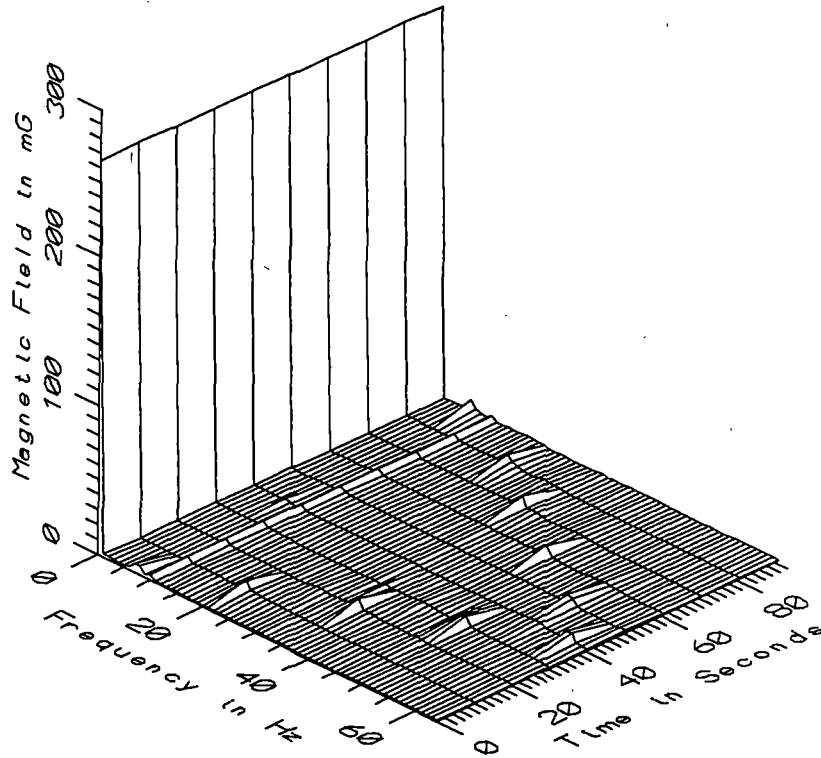

TGV011 - REFERENCE PROBE - ON CHAIR NEAR CONSOLE IN TGV CONTROL CENTER

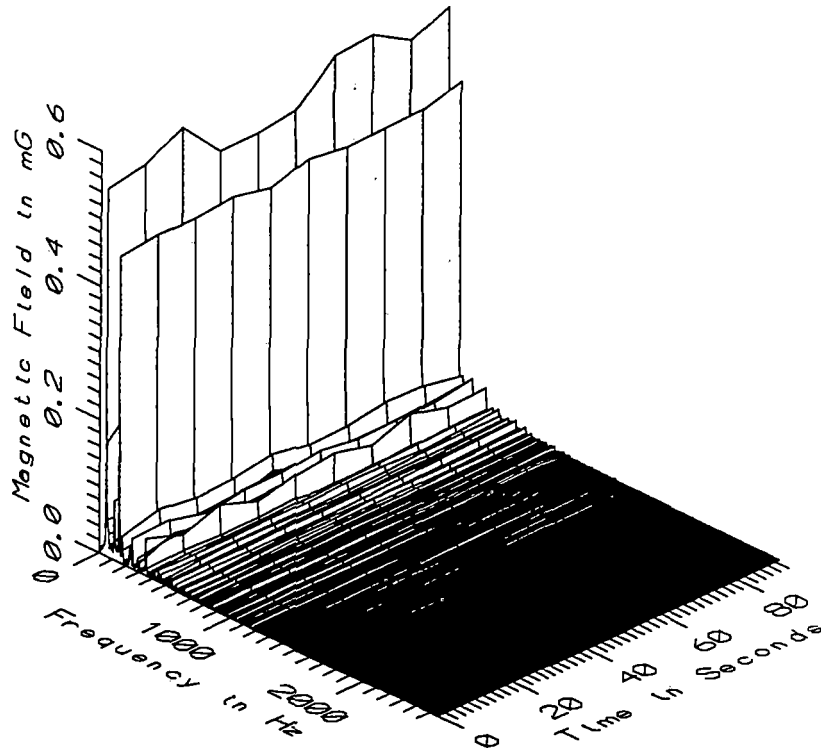

TGV011 - REFERENCE PROBE - ON CHAIR NEAR CONSOLE IN TGV CONTROL CENTER

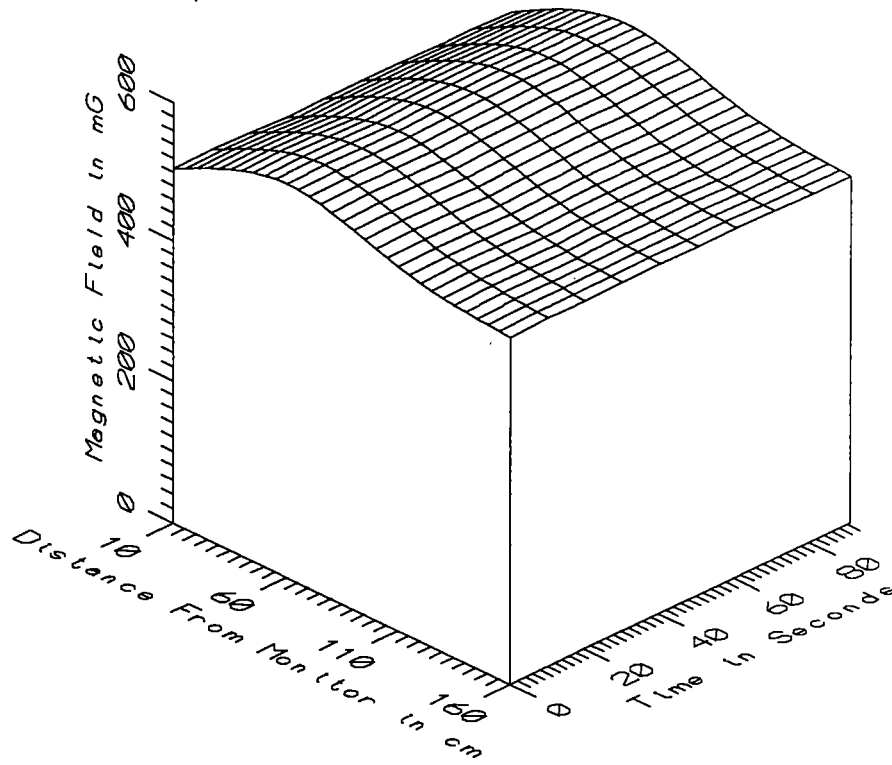

TGV011 - FROM MONITOR IN TGV CONTROL CENTER - STATIC

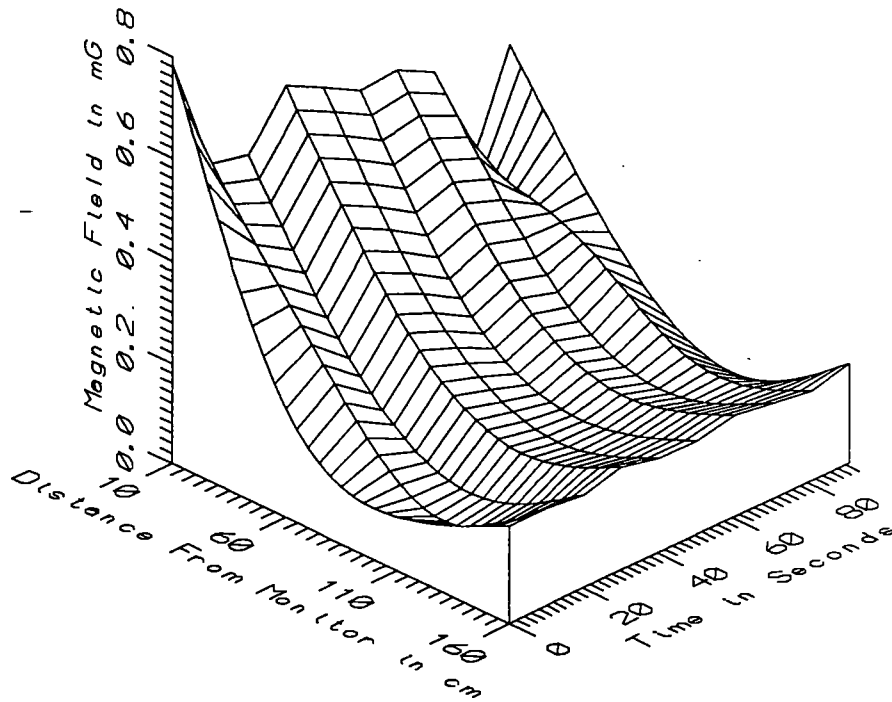

TGV011 - FROM MONITOR IN TGV CONTROL CENTER - LOW FREQ, 5-45Hz

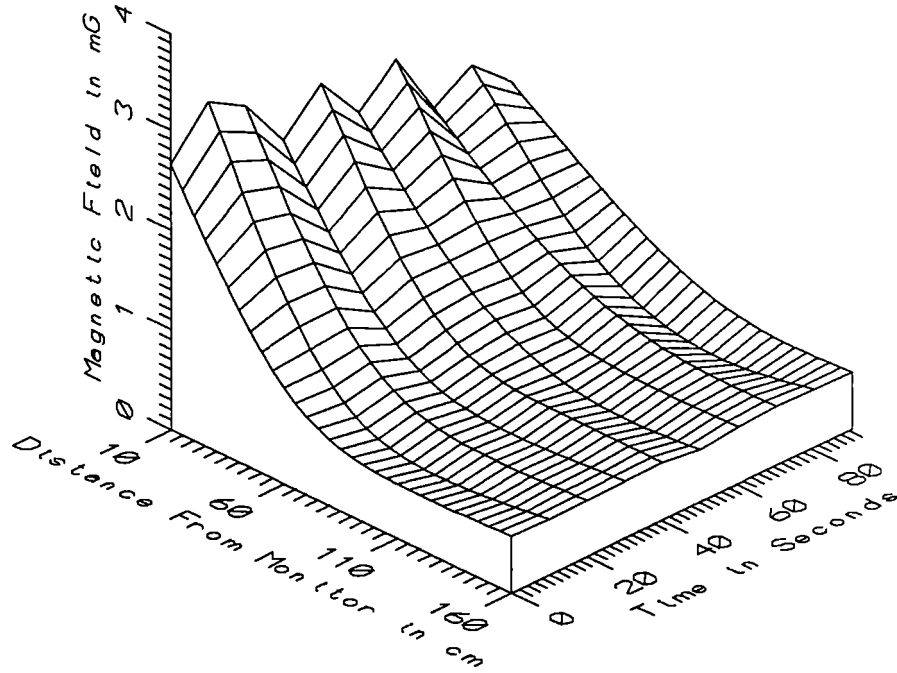

TGV011 - FROM MONITOR IN TGV CONTROL CENTER - POWER FREQ, 50-60Hz

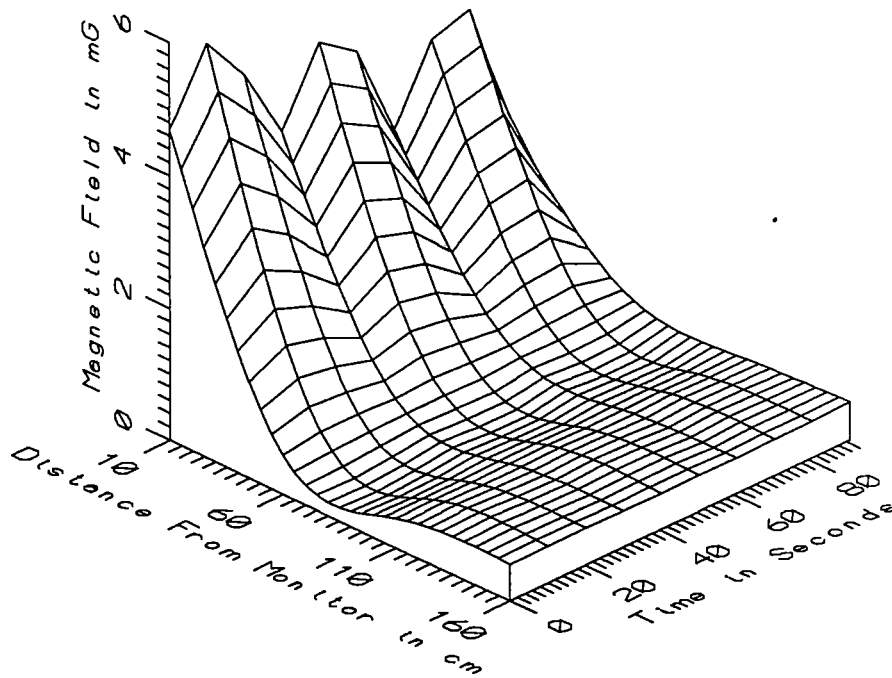

TGV011 - FROM MONITOR IN TGV CONTROL CENTER - POWER HARM, 65-300Hz

TGV011 - FROM MONITOR IN TGV CONTROL CENTER - ALL FREQ, 5-2560HZ

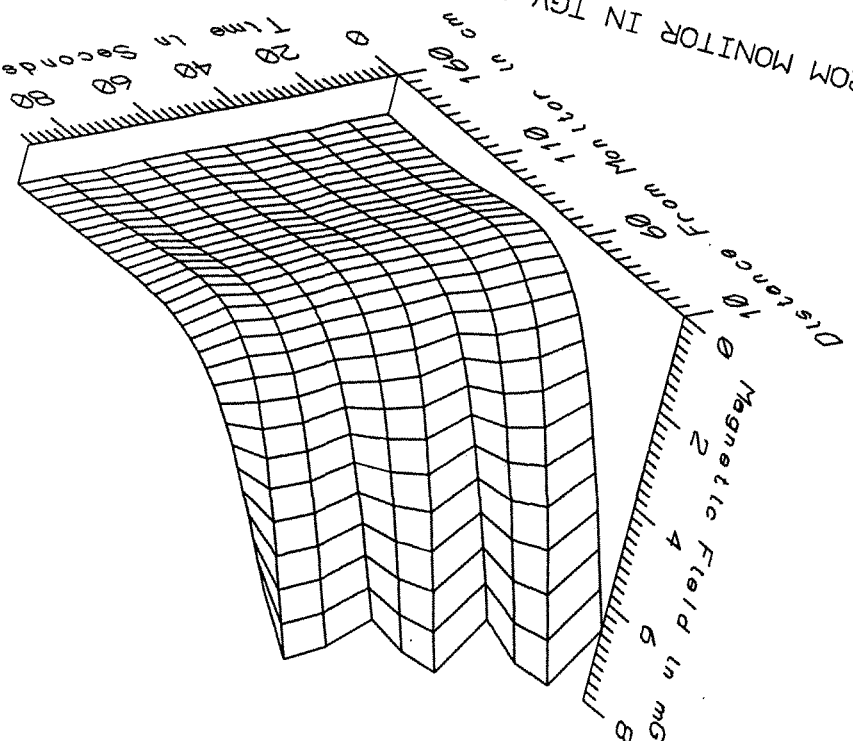

TGV011 - FROM MONITOR IN TGV CONTROL CENTER - HIGH FREQ, 305-2560HZ

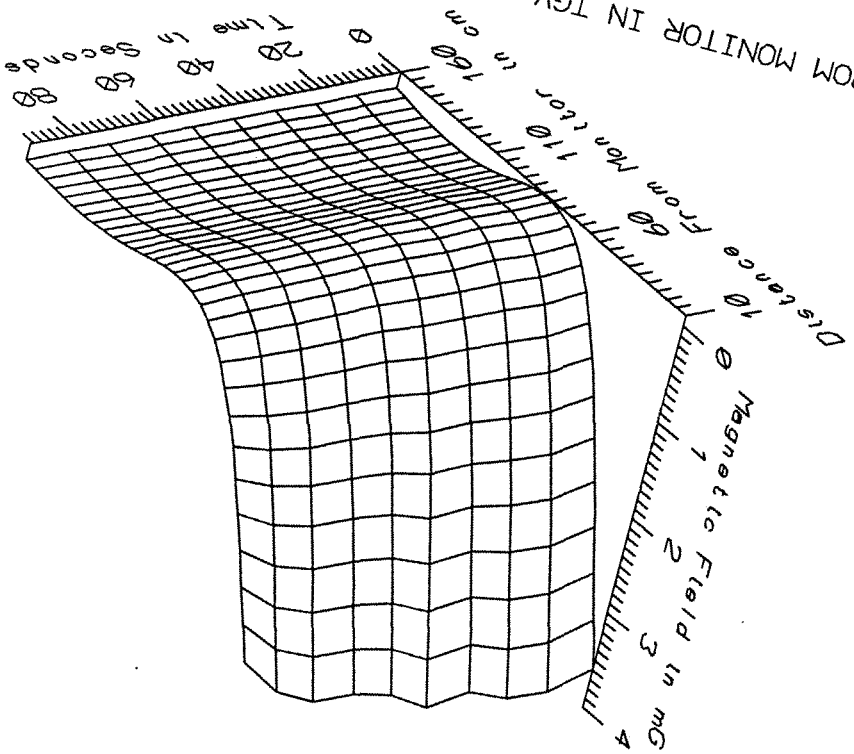



TGV011 - TGV CONTROL CENTER, GARE MONTPARNASSE				TOTAL OF 10 SAMPLES		
FREQUENCY BAND	DIST. FROM CRT (cm)	MINIMUM MAGNETIC FIELD (mG)	MAXIMUM MAGNETIC FIELD (mG)	AVERAGE MAGNETIC FIELD (mG)	STANDARD DEVIATION (mG)	COEFFICIENT OF VARIATION (%)
STATIC	10	501.18	507.78	504.01	2.07	0.41
	60	560.21	564.84	562.76	1.56	0.28
	110	516.04	520.29	518.63	1.59	0.31
	160	492.40	496.14	494.39	0.97	0.20
5-45Hz LOW FREQ	10	0.31	0.78	0.56	0.12	21.40
	60	0.21	0.30	0.24	0.03	12.43
	110	0.07	0.14	0.11	0.03	23.25
	160	0.18	0.21	0.19	0.01	4.25
50-60Hz PWR FREQ	10	1.87	3.10	2.47	0.40	16.25
	60	0.85	1.07	0.98	0.06	6.35
	110	0.44	0.63	0.53	0.06	11.39
	160	0.52	0.59	0.56	0.02	3.51
65-300Hz PWR HARM	10	2.38	5.71	4.25	0.97	22.75
	60	0.59	0.69	0.65	0.03	4.49
	110	0.45	0.47	0.46	0.01	1.87
	160	0.55	0.57	0.56	0.01	1.45
305-2560Hz HIGH FREQ	10	2.81	3.75	3.47	0.29	8.35
	60	0.22	0.25	0.23	0.01	3.90
	110	0.07	0.08	0.08	0.00	5.29
	160	0.04	0.06	0.05	0.00	8.00
5-2560Hz ALL FREQ	10	4.16	7.52	6.07	0.94	15.48
	60	1.13	1.29	1.22	0.05	3.96
	110	0.65	0.80	0.71	0.05	6.72
	160	0.79	0.84	0.82	0.01	1.72

**APPENDIX M**

**DATASET TGV012  
CENTER OF FIRST CLASS COACH R2B**

Measurement Setup Code:         Staff: 13         Reference: 16  
   Drawing: A-1

Vehicle Status:                   Coach trip from Montparnasse  
   station in Paris to Vendome station

Measurement Date:               September 8, 1992

Measurement Time:               Start:       14:03:10  
   End:        14:20:10

Number of Samples:               95

Programmed Sample Interval:    10 sec

Actual Sample Interval:         10.9 sec

**Frequency Spectrum Parameters**

<u>Probe Type:</u>	<u>Wideband</u>	<u>Static</u>
Maximum Frequency (Hz)	2560	64
Minimum Frequency (Hz)	5	0
Spectral Bandwidth (Hz)	5	1

Missing or Suspect Data:       None

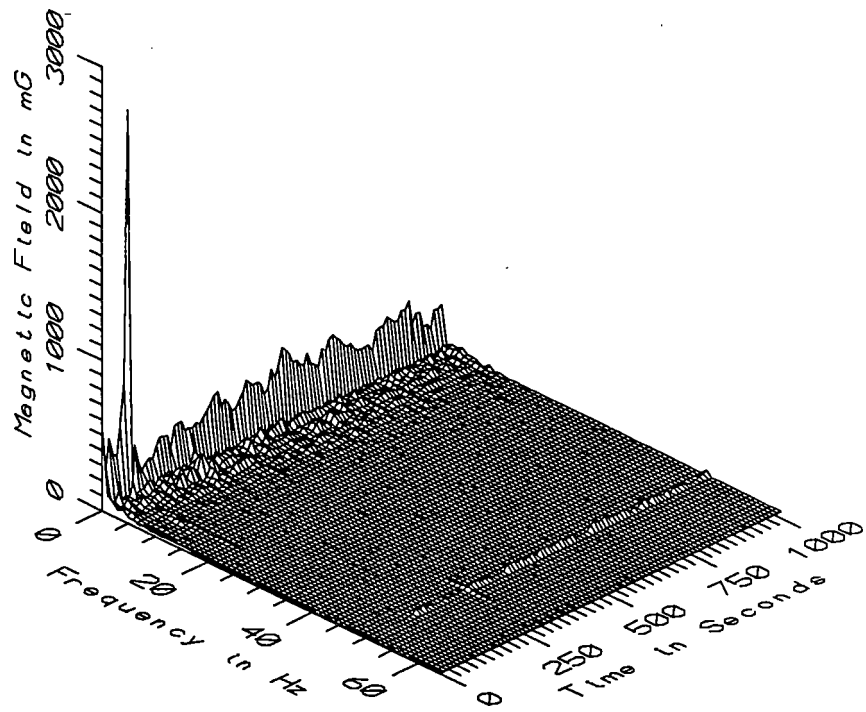

TGV012 - 10cm ABOVE FLOOR IN CENTER OF COACH R2B

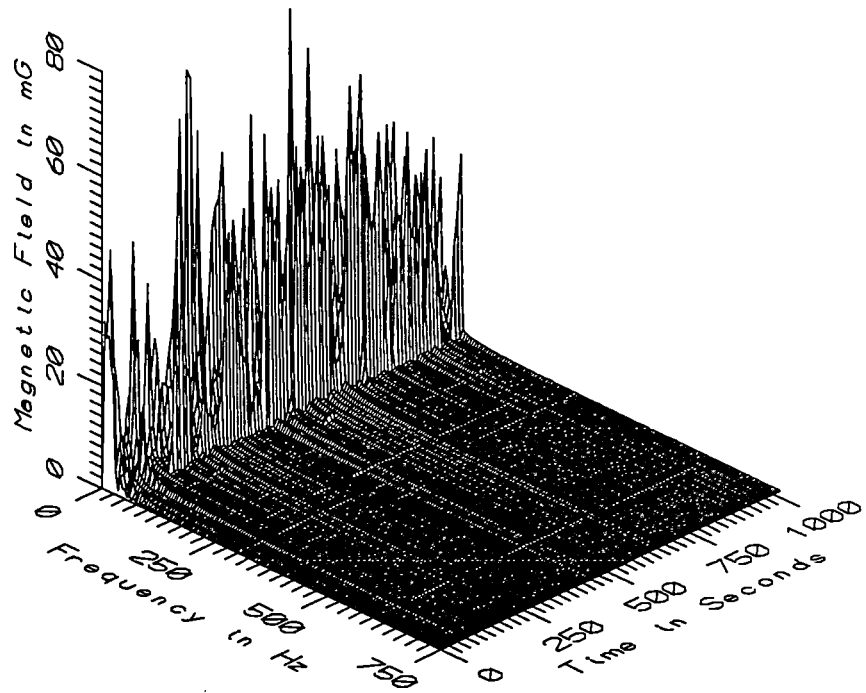

TGV012 - 10cm ABOVE FLOOR IN CENTER OF COACH R2B

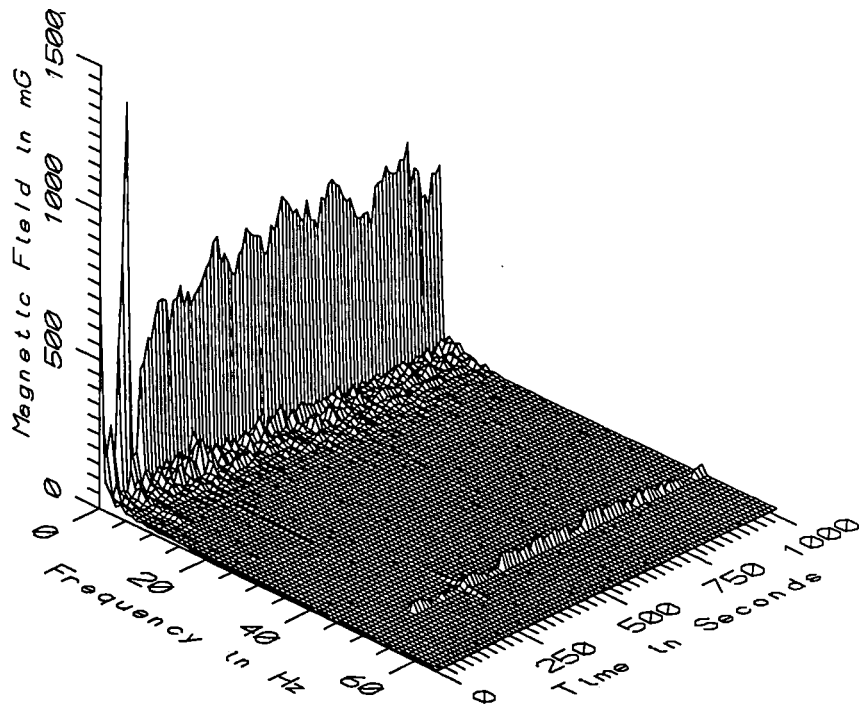

TGV012 - 60cm ABOVE FLOOR IN CENTER OF COACH R2B

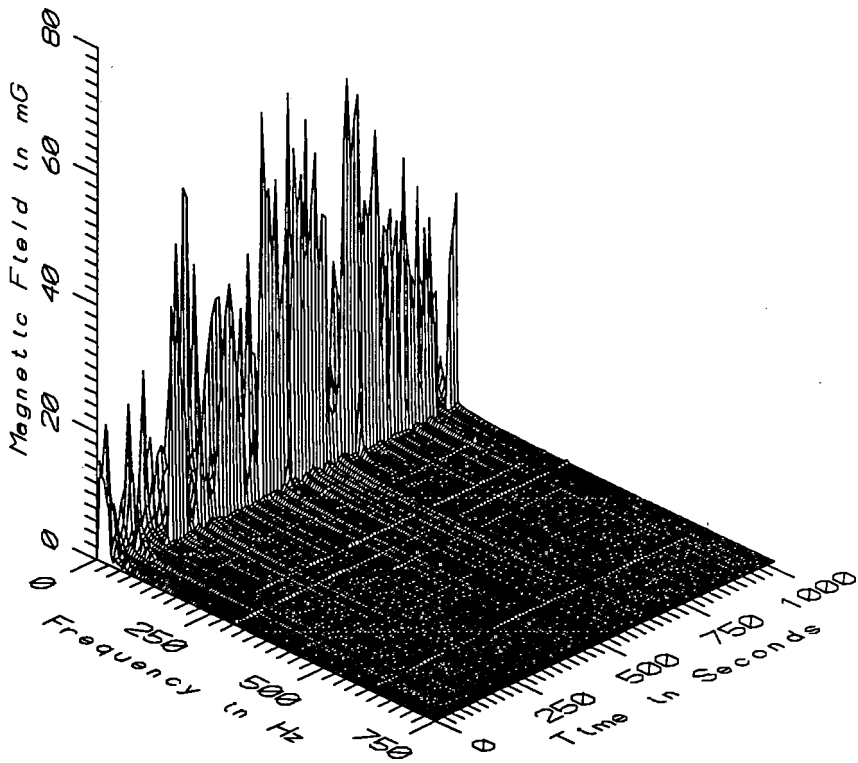

TGV012 - 60cm ABOVE FLOOR IN CENTER OF COACH R2B

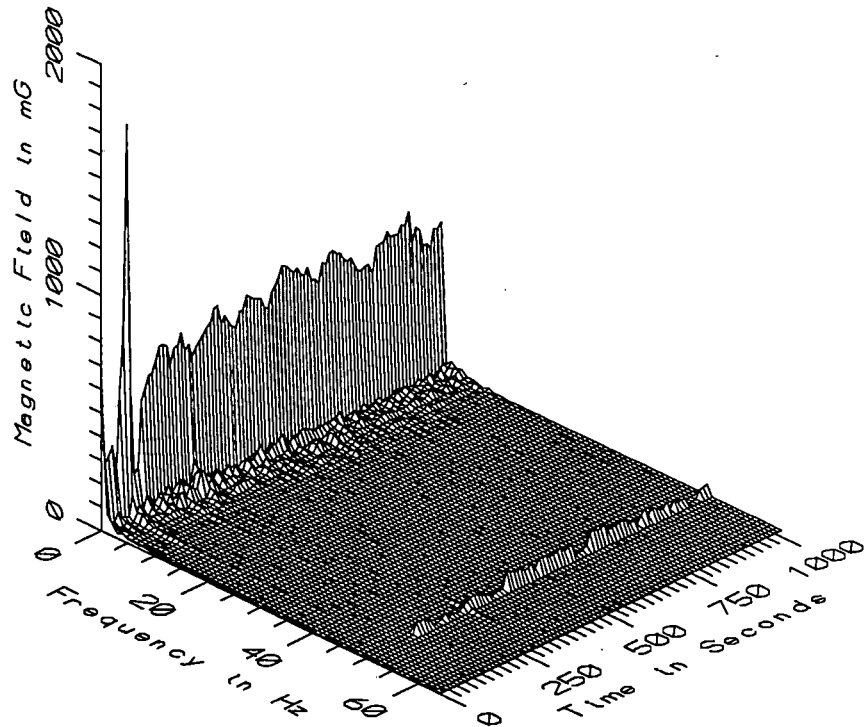

TGV012 - 110cm ABOVE FLOOR IN CENTER OF COACH R2B

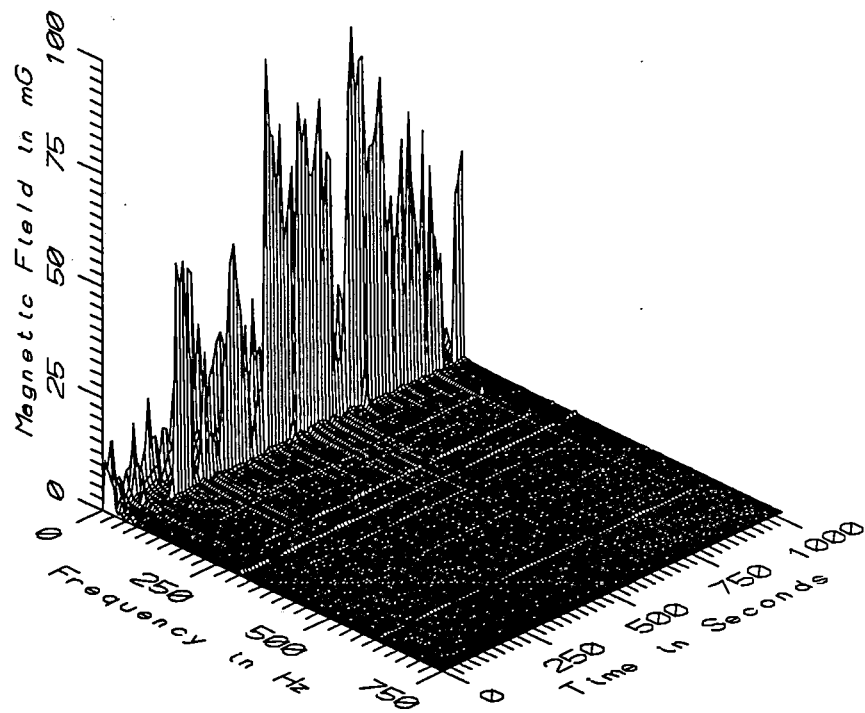

TGV012 - 110cm ABOVE FLOOR IN CENTER OF COACH R2B

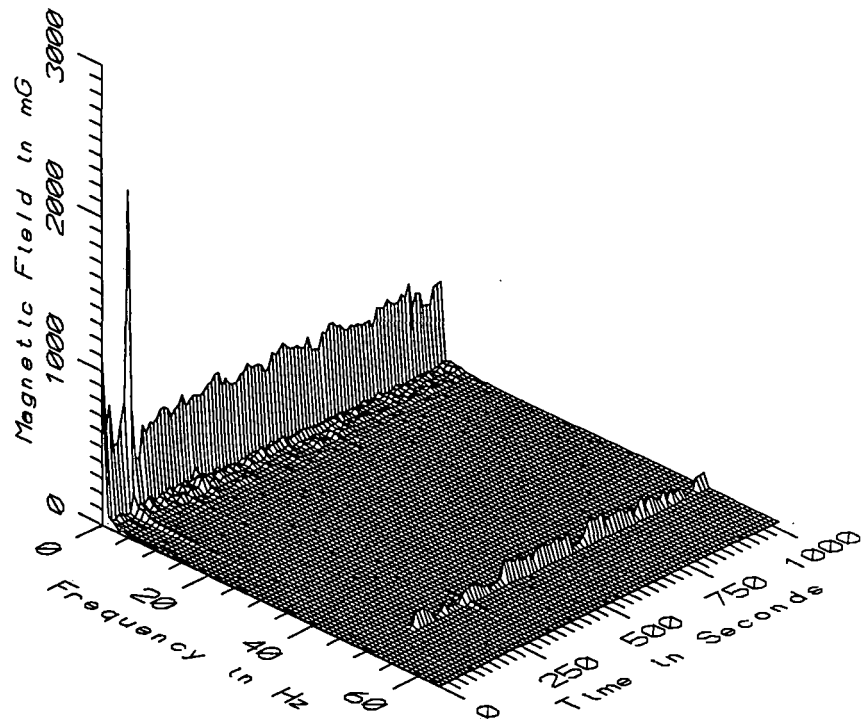

TGV012 - 160cm ABOVE FLOOR IN CENTER OF COACH R2B

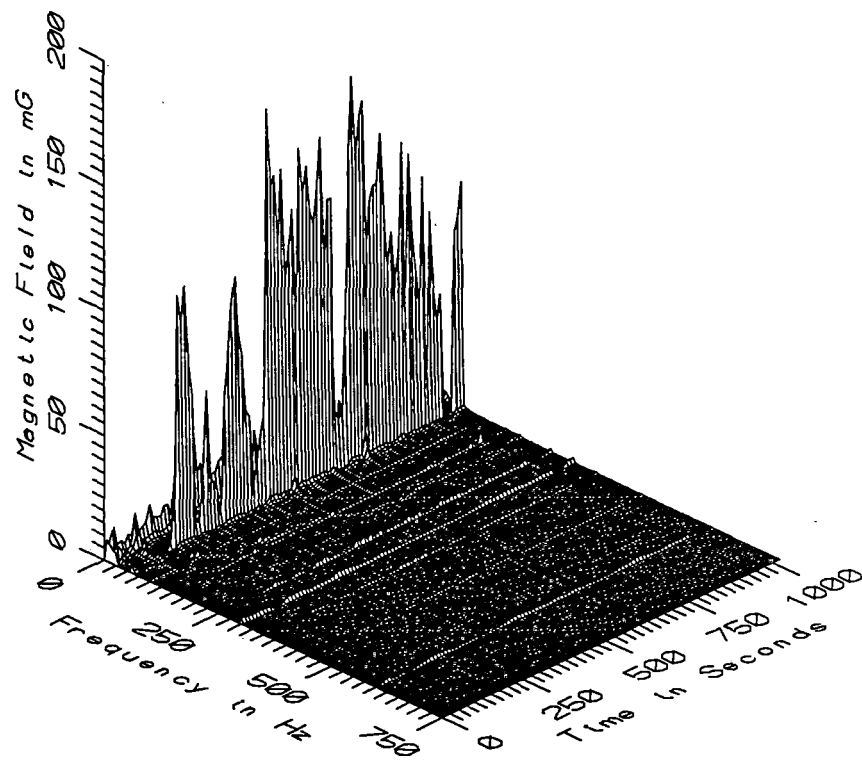

TGV012 - 160cm ABOVE FLOOR IN CENTER OF COACH R2B

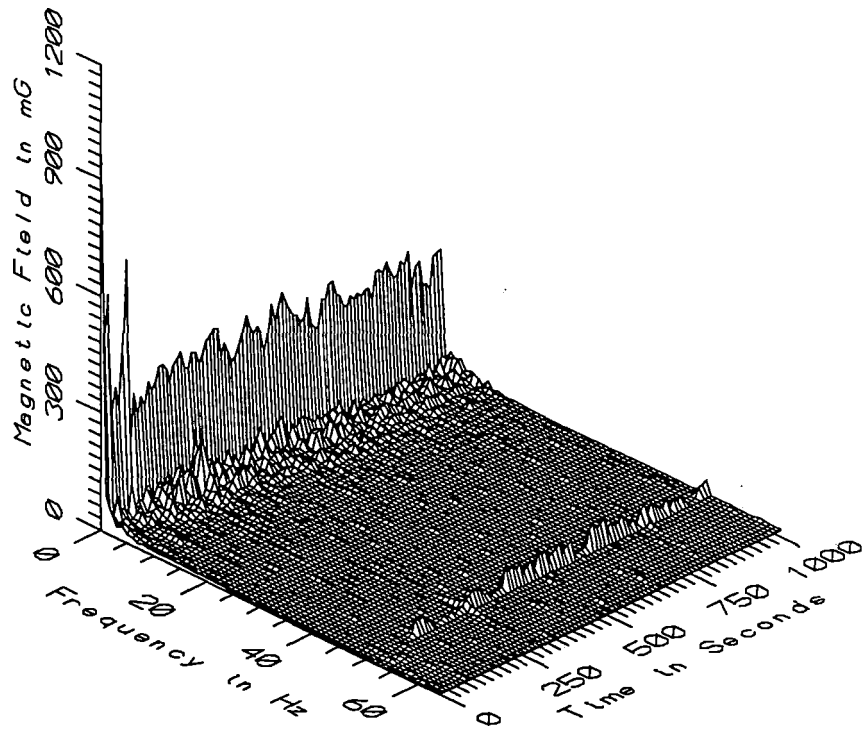

TGV012 - REFERENCE PROBE - ON MIDDLE SEAT IN COACH R2B

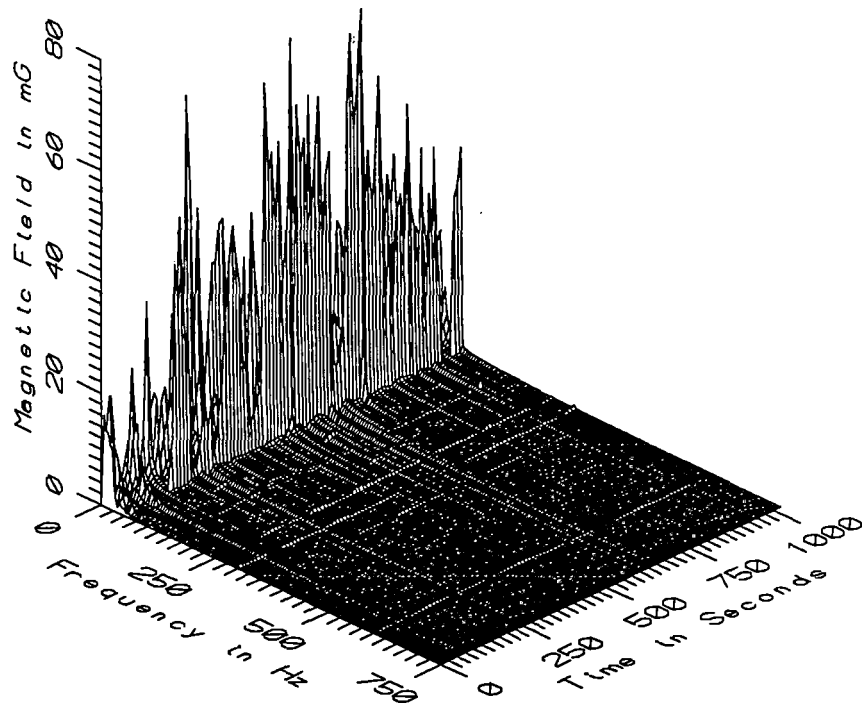

TGV012 - REFERENCE PROBE - ON MIDDLE SEAT IN COACH R2B

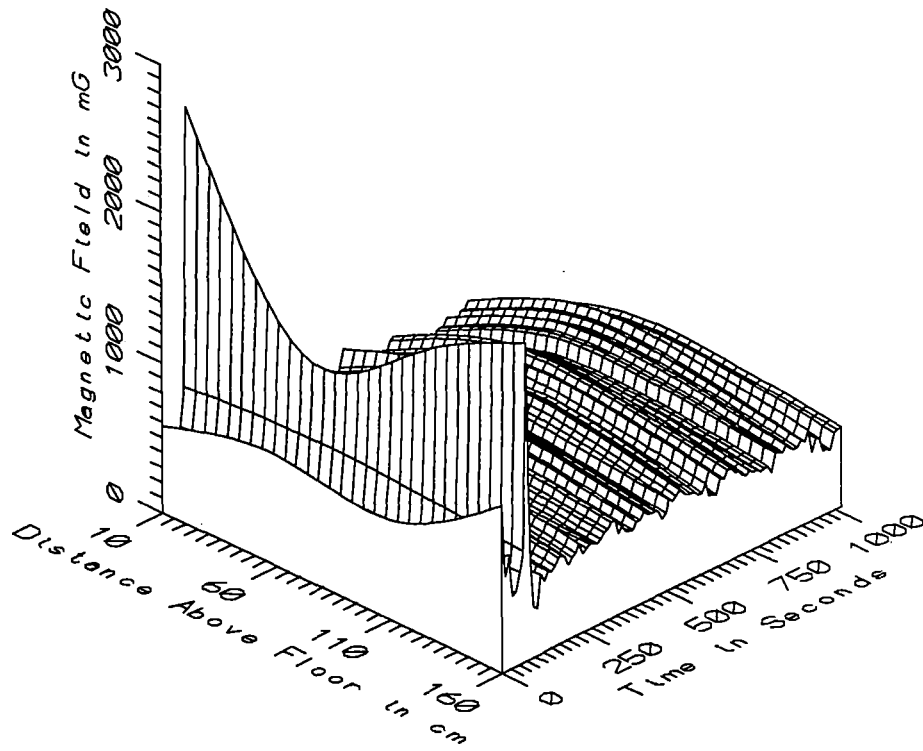

TGVO12 - CENTER OF COACH R2B - STATIC

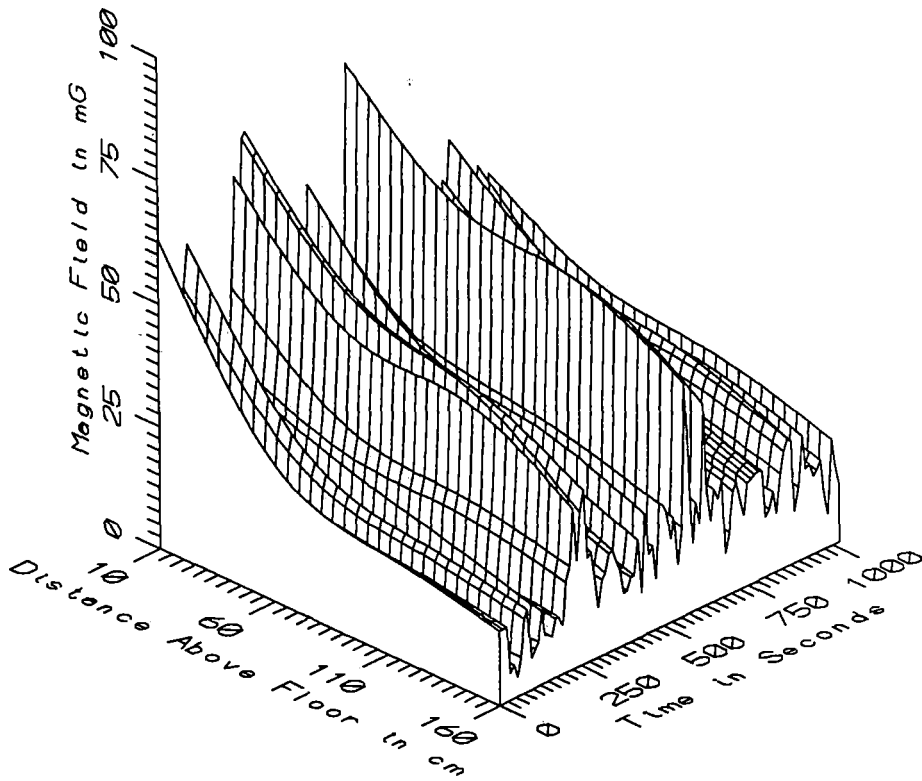

TGVO12 - CENTER OF COACH R2B - LOW FREQ, 5-45Hz



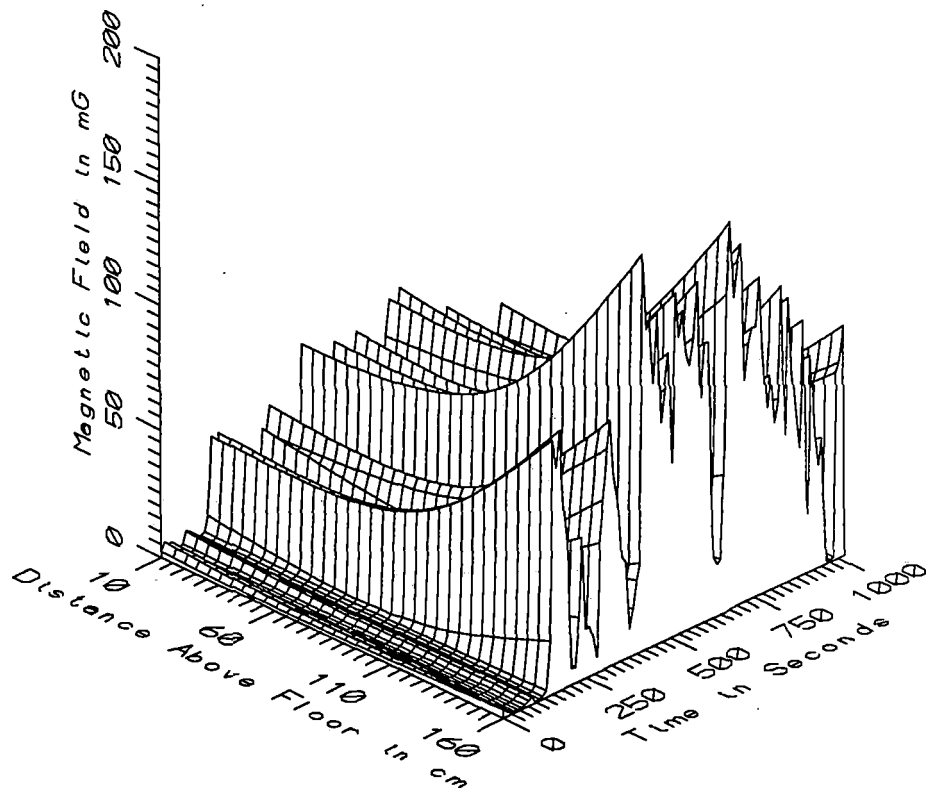

TGV012 - CENTER OF COACH R2B - POWER FREQ, 50-60Hz

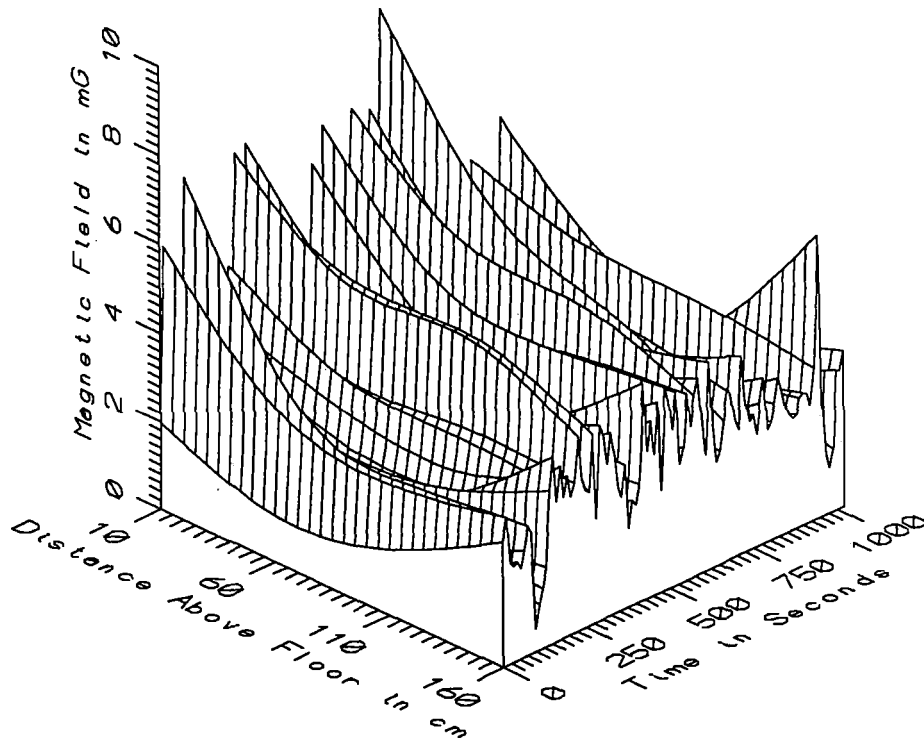

TGV012 - CENTER OF COACH R2B - POWER HARM, 65-300Hz

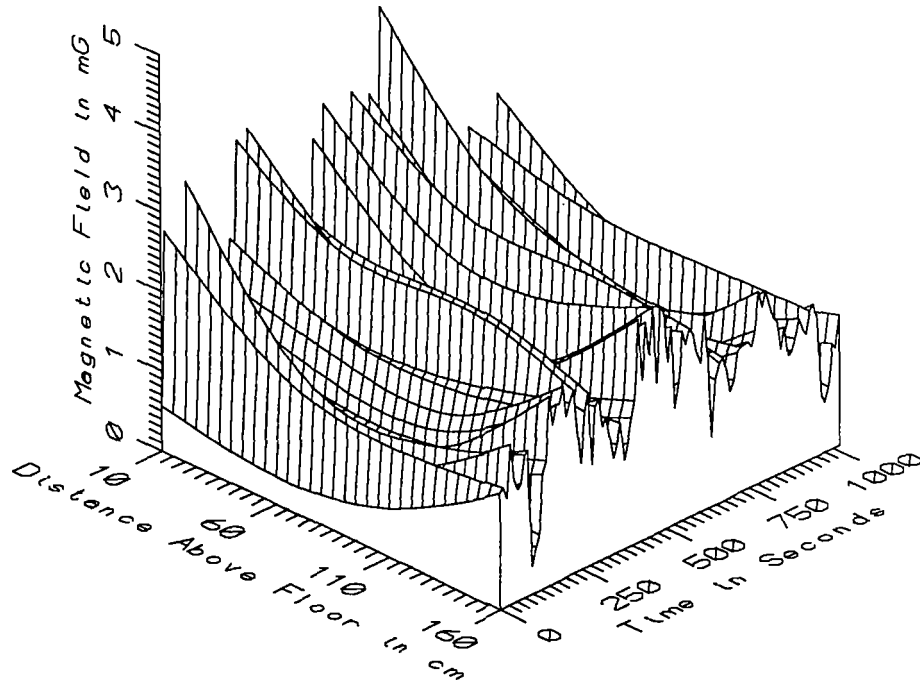

TGV012 - CENTER OF COACH R2B - HIGH FREQ, 305-2560Hz

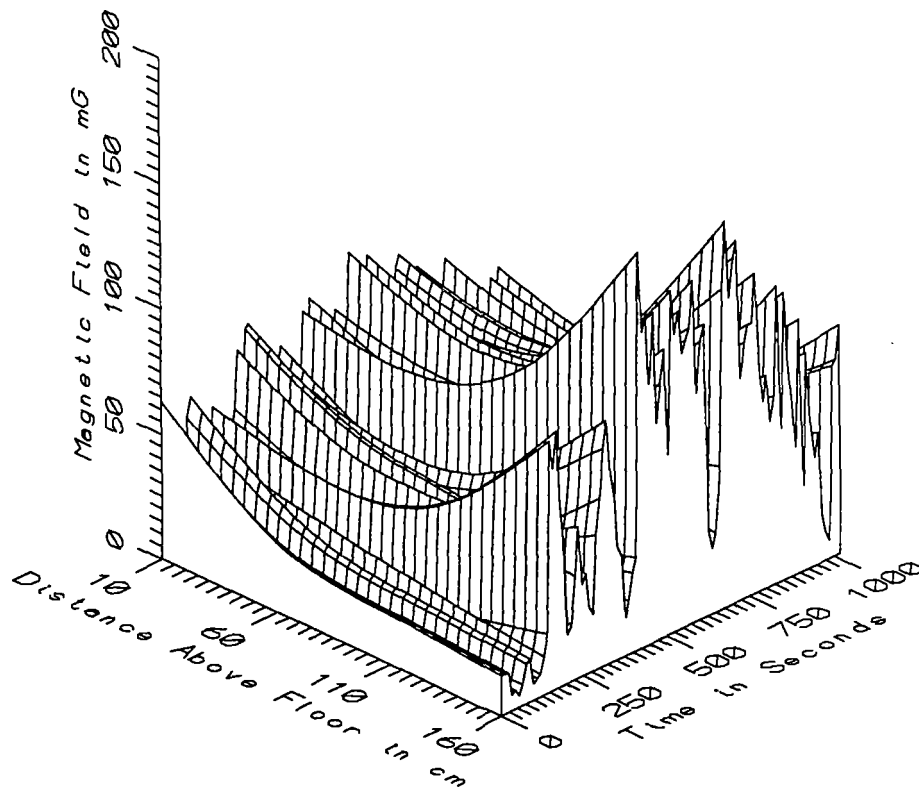

TGV012 - CENTER OF COACH R2B - ALL FREQ, 5-2560Hz

TGV012 - ALL SAMPLES		TOTAL OF 95 SAMPLES				
FREQUENCY BAND	HEIGHT ABOVE FLOOR (cm)	MINIMUM MAGNETIC FIELD (mG)	MAXIMUM MAGNETIC FIELD (mG)	AVERAGE MAGNETIC FIELD (mG)	STANDARD DEVIATION (mG)	COEFFICIENT OF VARIATION (%)
STATIC	10	140.82	2627.26	345.35	253.82	73.49
	60	125.07	1333.02	605.65	151.43	25.00
	110	175.66	1681.88	631.28	155.65	24.66
	160	310.83	2101.17	561.57	182.32	32.47
5-45Hz LOW FREQ	10	6.89	80.03	38.99	15.31	39.27
	60	4.58	61.49	25.74	10.59	41.12
	110	4.48	58.65	22.65	9.96	43.97
	160	4.15	47.39	17.63	7.40	41.94
50-60Hz PWR FREQ	10	0.43	60.97	22.13	16.38	74.02
	60	0.35	61.10	23.83	17.47	73.32
	110	0.39	87.84	35.23	25.63	72.75
	160	0.44	157.34	65.20	46.68	71.59
65-300Hz PWR HARM	10	0.60	8.92	3.43	1.71	49.97
	60	0.51	5.54	2.44	1.12	46.04
	110	0.41	5.54	2.47	1.01	40.95
	160	0.53	6.41	3.18	0.94	29.48
305-2560Hz HIGH FREQ	10	0.32	4.28	1.61	0.82	51.06
	60	0.25	2.68	1.16	0.54	46.22
	110	0.19	2.68	1.22	0.48	39.62
	160	0.35	2.86	1.77	0.50	28.24
5-2560Hz ALL FREQ	10	6.94	85.55	47.50	16.46	34.65
	60	4.65	71.58	37.74	15.19	40.24
	110	4.65	92.00	44.89	22.40	49.90
	160	4.89	158.71	70.19	43.34	61.75

TGV012 - DC SECTION		TOTAL OF 8 SAMPLES				
FREQUENCY BAND	HEIGHT ABOVE FLOOR (cm)	MINIMUM MAGNETIC FIELD (mG)	MAXIMUM MAGNETIC FIELD (mG)	AVERAGE MAGNETIC FIELD (mG)	STANDARD DEVIATION (mG)	COEFFICIENT OF VARIATION (%)
STATIC	10	273.91	2627.26	732.39	782.84	106.89
	60	153.62	1333.02	529.67	409.64	77.34
	110	242.49	1681.88	604.70	477.54	78.97
	160	473.15	2101.17	859.14	539.35	62.78
5-45Hz LOW FREQ	10	6.89	63.09	36.16	21.68	59.95
	60	4.58	28.01	17.38	9.54	54.90
	110	4.48	19.96	13.12	6.66	50.79
	160	4.15	15.54	10.83	5.10	47.05
50-60Hz PWR FREQ	10	0.43	5.61	2.90	2.01	69.36
	60	0.35	2.72	1.37	0.92	66.86
	110	0.41	2.18	1.23	0.70	56.72
	160	0.67	3.42	1.45	0.97	67.10
65-300Hz PWR HARM	10	0.60	7.22	3.36	2.38	71.01
	60	0.63	3.42	1.72	1.06	61.37
	110	1.02	2.93	1.71	0.70	40.72
	160	2.08	3.41	2.58	0.47	18.05
305-2560Hz HIGH FREQ	10	0.32	3.22	1.47	1.14	77.56
	60	0.35	1.62	0.80	0.51	63.87
	110	0.58	1.35	0.86	0.32	36.57
	160	1.36	2.02	1.57	0.23	14.51
5-2560Hz ALL FREQ	10	6.94	63.15	36.56	21.76	59.51
	60	4.65	28.06	17.57	9.59	54.59
	110	4.65	20.10	13.34	6.69	50.13
	160	4.89	16.24	11.42	5.01	43.84

TGV012 - TRANSITION BETWEEN DC AND AC SECTIONS					TOTAL OF 6 SAMPLES	
FREQUENCY BAND	HEIGHT ABOVE FLOOR (cm)	MINIMUM MAGNETIC FIELD (mG)	MAXIMUM MAGNETIC FIELD (mG)	AVERAGE MAGNETIC FIELD (mG)	STANDARD DEVIATION (mG)	COEFFICIENT OF VARIATION (%)
STATIC	10	140.82	327.04	201.97	64.78	32.07
	60	125.07	498.87	343.34	169.35	49.33
	110	175.66	588.22	418.24	184.07	44.01
	160	310.83	766.24	484.56	164.65	33.98
5-45Hz LOW FREQ	10	8.04	59.24	25.03	19.67	78.60
	60	5.66	28.20	15.76	9.75	61.91
	110	6.92	21.17	13.16	6.36	48.34
	160	6.65	16.95	10.98	4.11	37.45
50-60Hz PWR FREQ	10	0.52	7.56	2.70	2.83	104.93
	60	0.36	2.61	1.42	0.98	68.90
	110	0.39	5.42	1.88	1.86	99.23
	160	0.44	21.79	4.86	8.35	171.63
65-300Hz PWR HARM	10	0.78	3.11	2.04	1.07	52.50
	60	0.51	2.28	1.57	0.74	47.08
	110	0.41	2.42	1.53	0.73	47.95
	160	0.53	3.55	1.86	1.13	60.66
305-2560Hz HIGH FREQ	10	0.38	1.46	0.96	0.49	50.74
	60	0.25	1.09	0.76	0.36	47.00
	110	0.19	1.16	0.77	0.37	48.56
	160	0.35	1.83	1.08	0.62	57.11
5-2560Hz ALL FREQ	10	8.15	59.52	25.42	19.70	77.50
	60	5.80	28.42	15.94	9.78	61.37
	110	6.95	21.30	13.51	6.43	47.58
	160	6.70	24.25	13.58	6.75	49.67

TGV012 AC SECTION		TOTAL OF 81 SAMPLES				
FREQUENCY BAND	HEIGHT ABOVE FLOOR (cm)	MINIMUM MAGNETIC FIELD (mG)	MAXIMUM MAGNETIC FIELD (mG)	AVERAGE MAGNETIC FIELD (mG)	STANDARD DEVIATION (mG)	COEFFICIENT OF VARIATION (%)
STATIC	10	165.41	505.04	317.75	67.21	21.15
	60	484.83	759.11	632.58	63.22	9.99
	110	538.07	762.29	649.69	50.76	7.81
	160	406.17	630.14	537.89	45.18	8.40
5-45Hz LOW FREQ	10	12.90	80.03	40.30	13.89	34.47
	60	8.02	61.49	27.31	10.04	36.77
	110	7.73	58.65	24.29	9.57	39.39
	160	6.93	47.39	18.80	7.18	38.22
50-60Hz PWR FREQ	10	1.50	60.97	25.46	15.42	60.55
	60	0.86	61.10	27.71	15.98	57.66
	110	1.00	87.84	41.06	23.20	56.50
	160	0.75	157.34	75.96	41.94	55.20
65-300Hz PWR HARM	10	1.21	8.92	3.54	1.65	46.63
	60	0.93	5.54	2.57	1.10	42.97
	110	1.13	5.54	2.61	0.99	37.90
	160	1.06	6.41	3.33	0.86	25.82
305-2560Hz HIGH FREQ	10	0.42	4.28	1.67	0.79	47.41
	60	0.41	2.68	1.23	0.53	42.99
	110	0.50	2.68	1.28	0.47	36.82
	160	0.63	2.86	1.85	0.47	25.45
5-2560Hz ALL FREQ	10	14.32	85.55	50.22	14.02	27.92
	60	9.58	71.58	41.35	12.94	31.30
	110	8.24	92.00	50.33	19.48	38.71
	160	7.23	158.71	80.19	38.93	48.54

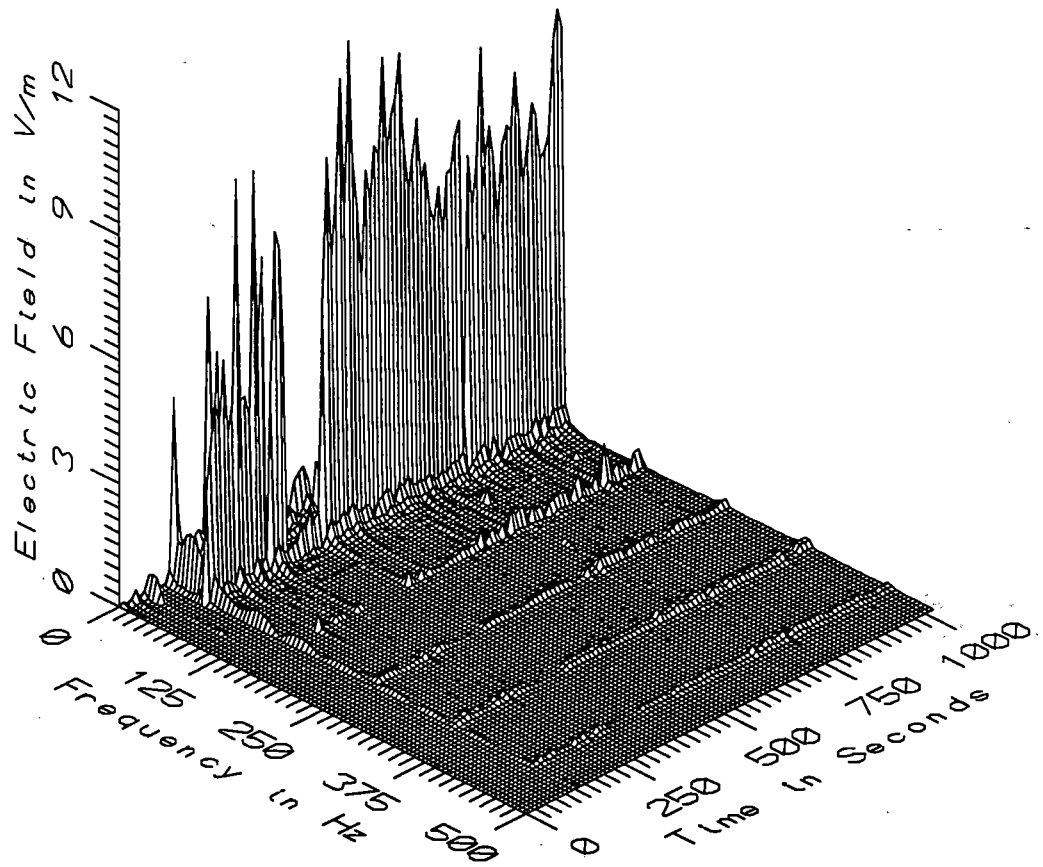

TGV012 - ELECTRIC FIELD IN COACH R2B

APPENDIX N

DATASET TGV013  
TRANSVERSE PROFILE FROM SIDE WALL OF FIRST CLASS COACH R2B

Measurement Setup Code:           Staff: 14       Reference: 16  
  Drawing: A-1

Vehicle Status:                   Coach trip from Montparnasse  
  station in Paris to Vendome station

Measurement Date:                September 8, 1992

Measurement Time:                Start:     14:21:32  
  End:       14:26:00

Number of Samples:               10

Programmed Sample Interval:     30 sec

Actual Sample Interval:         29.8 sec

Frequency Spectrum Parameters

<u>Probe Type:</u>	<u>Wideband</u>	<u>Static</u>
Maximum Frequency (Hz)	2560	64
Minimum Frequency (Hz)	5	0
Spectral Bandwidth (Hz)	5	1

Missing or Suspect Data:       None



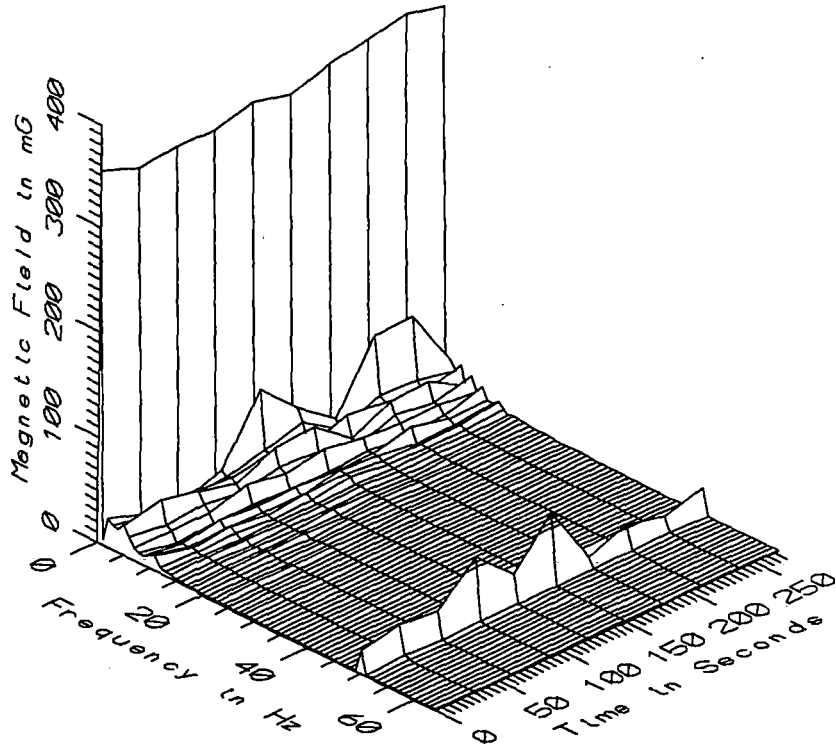

TGV013 - 10cm FROM SIDE WALL ABOVE SEATS 42 & 43 IN COACH R2B

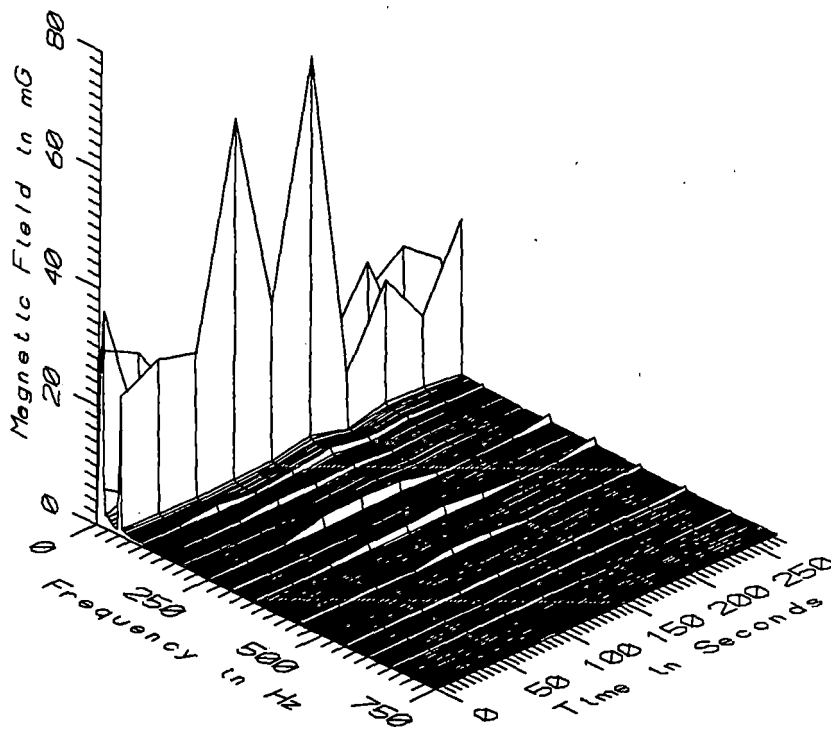

TGV013 - 10cm FROM SIDE WALL ABOVE SEATS 42 & 43 IN COACH R2B

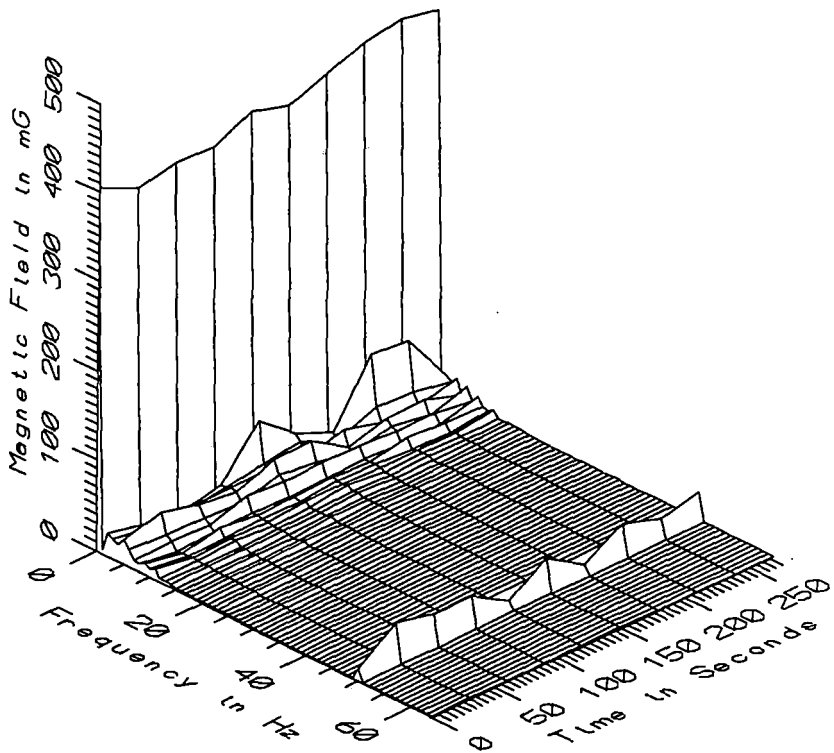

TGV013 - 60cm FROM SIDE WALL ABOVE SEATS 42 & 43 IN COACH R2B

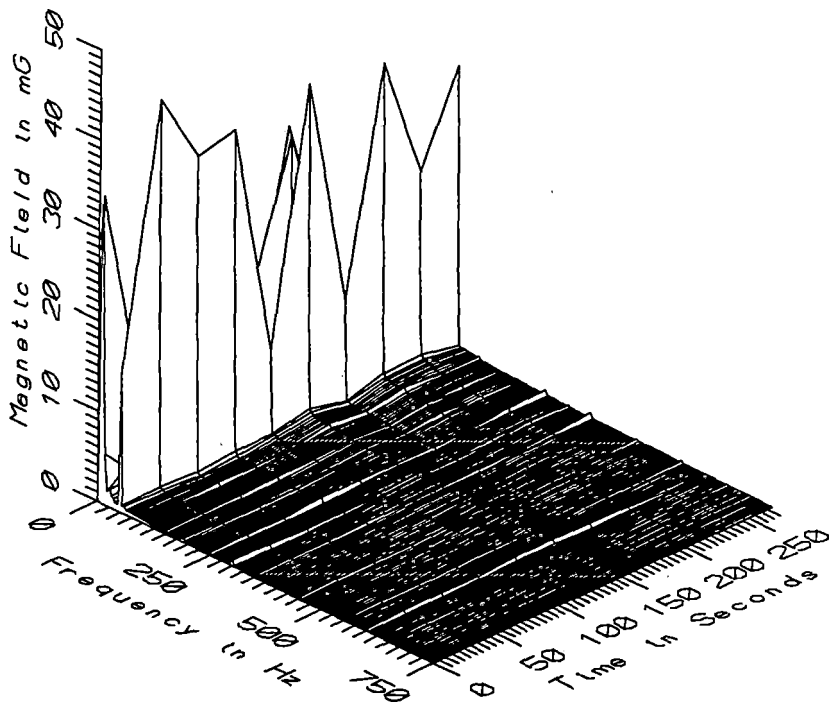

TGV013 - 60cm FROM SIDE WALL ABOVE SEATS 42 & 43 IN COACH R2B

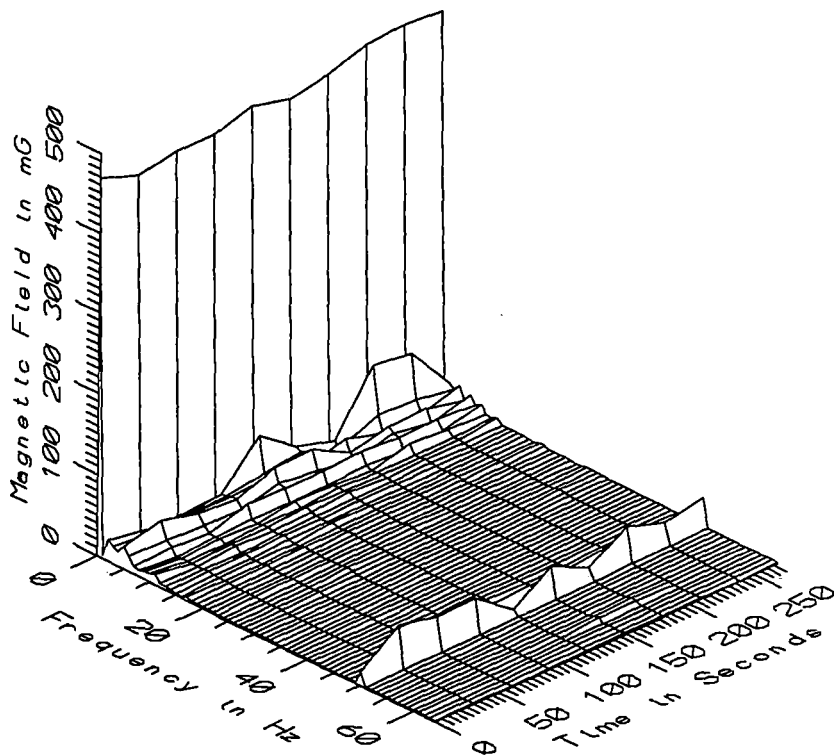

TGV013 - 110cm FROM SIDE WALL ABOVE SEATS 42 & 43 IN COACH R2B

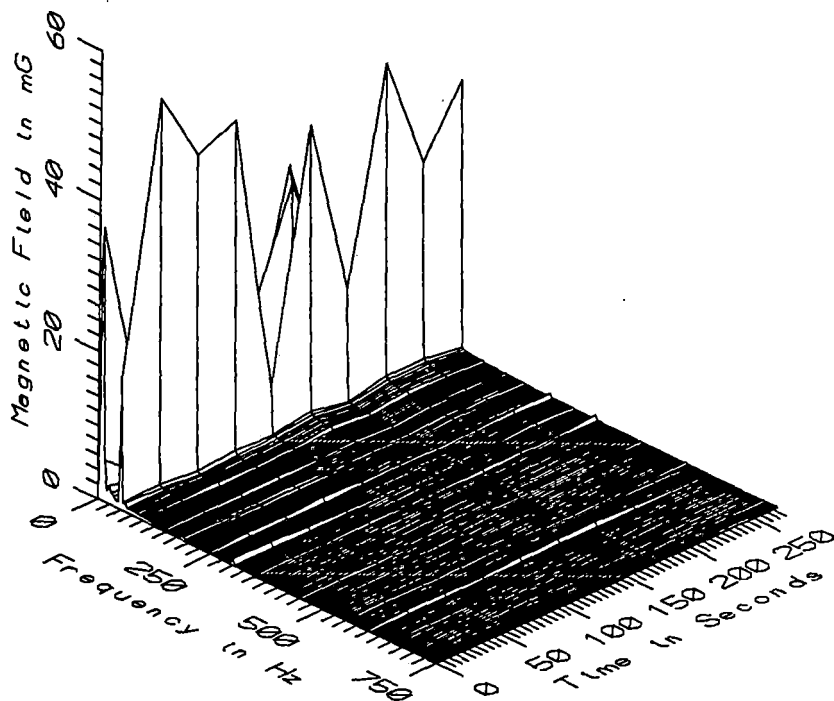

TGV013 - 110cm FROM SIDE WALL ABOVE SEATS 42 & 43 IN COACH R2B

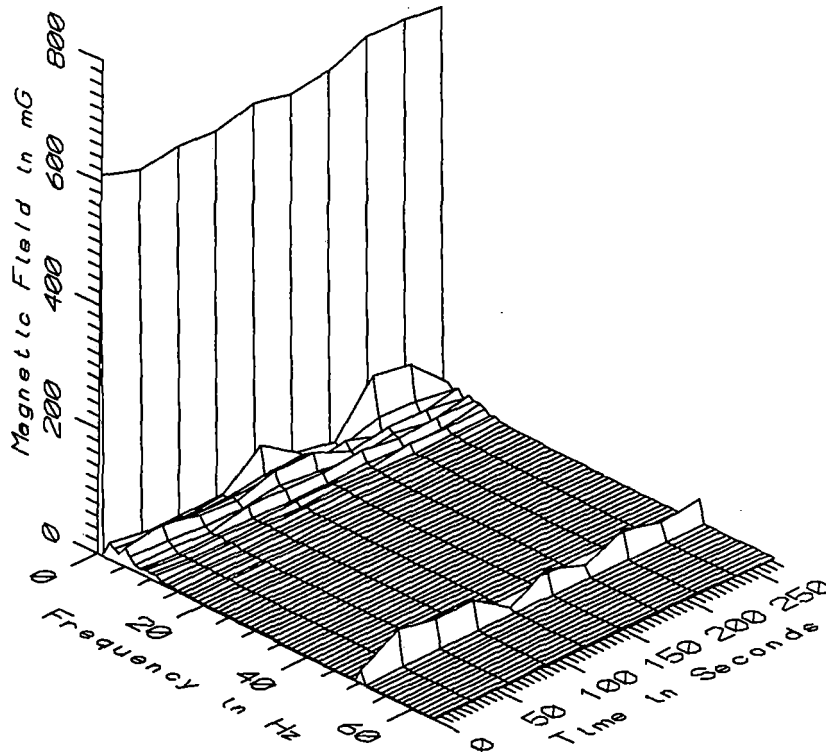

TGV013 - 160cm FROM SIDE WALL ABOVE SEATS 42 & 43 IN COACH R2B

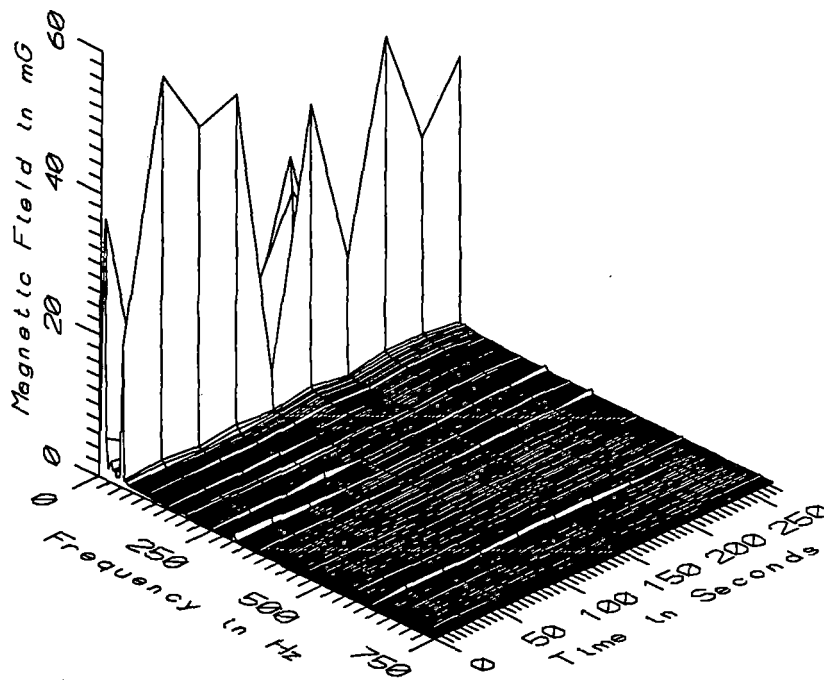

TGV013 - 160cm FROM SIDE WALL ABOVE SEATS 42 & 43 IN COACH R2B

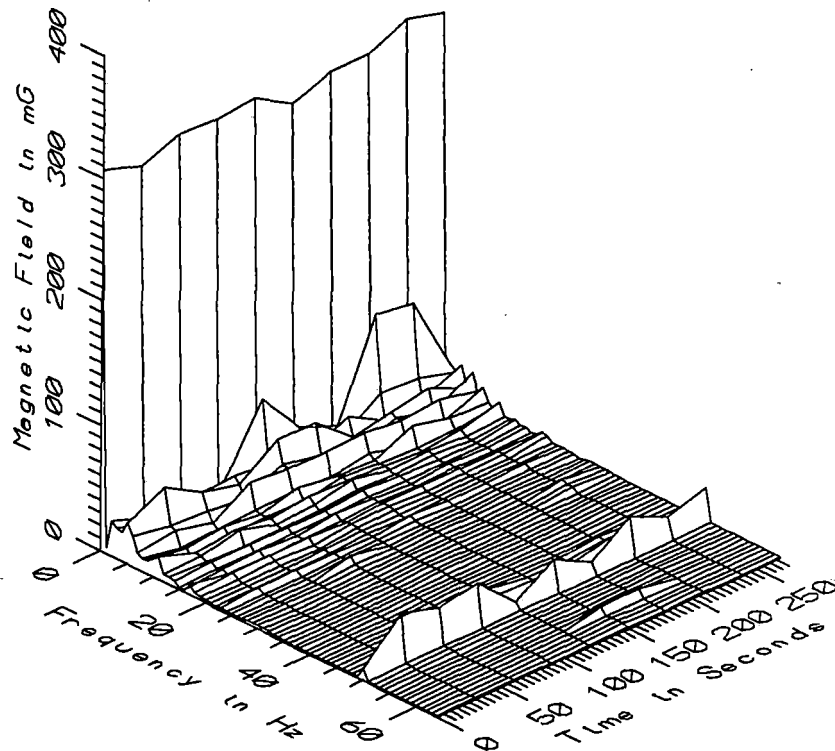

TGV013 - REFERENCE PROBE - ON MIDDLE SEAT IN COACH R2B

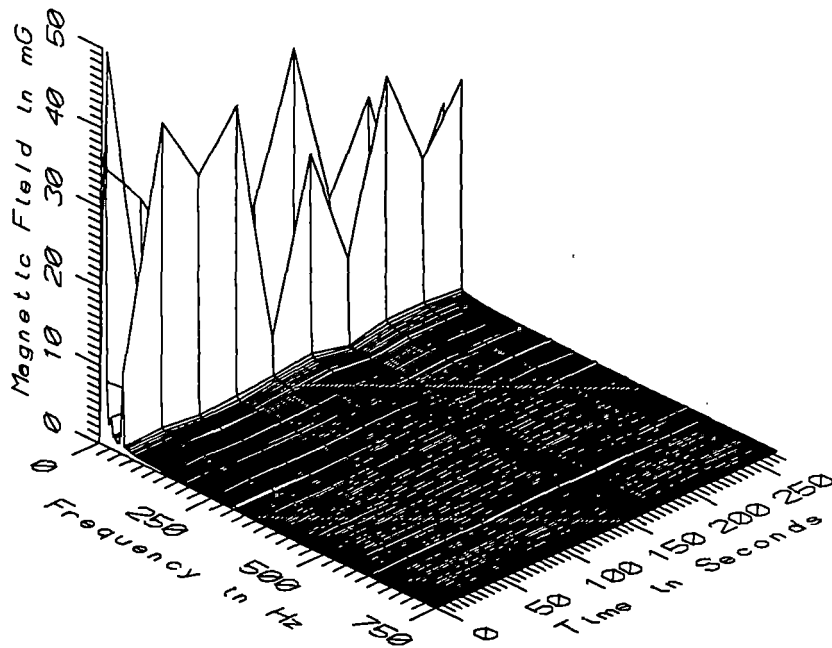

TGV013 - REFERENCE PROBE - ON MIDDLE SEAT IN COACH R2B

031541050103031000

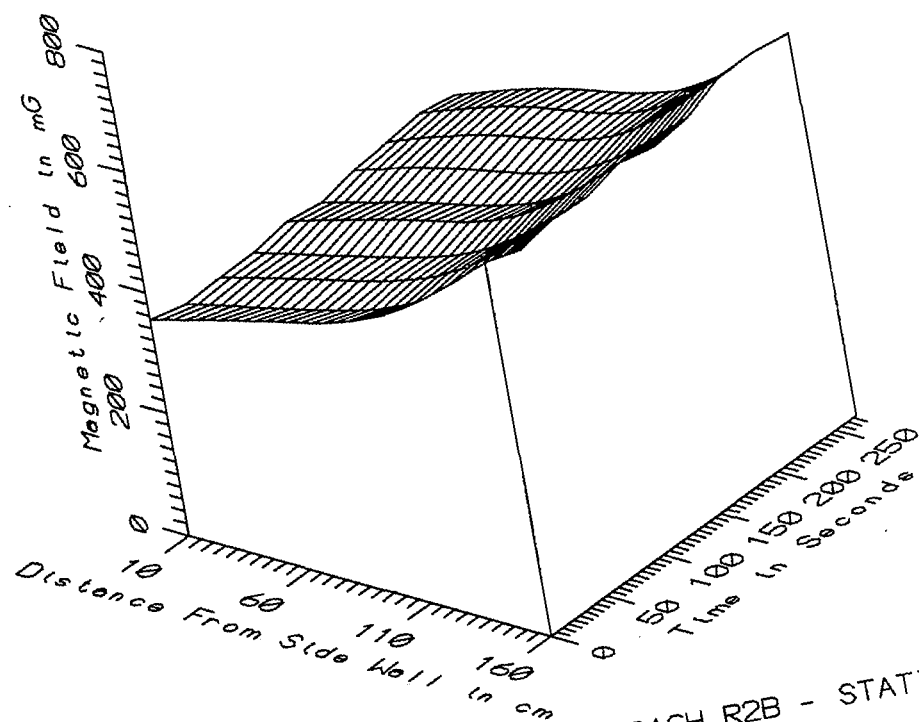

TGV013 - ABOVE SEATS 42 & 43 IN COACH R2B - STATIC

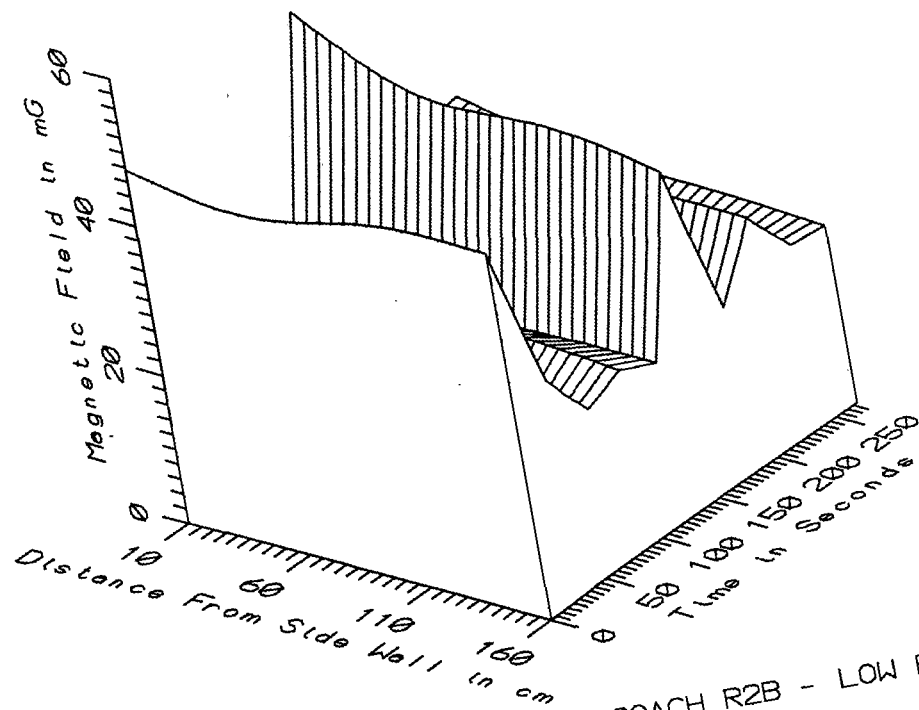

TGV013 - ABOVE SEATS 42 & 43 IN COACH R2B - LOW FREQ, 5-45Hz

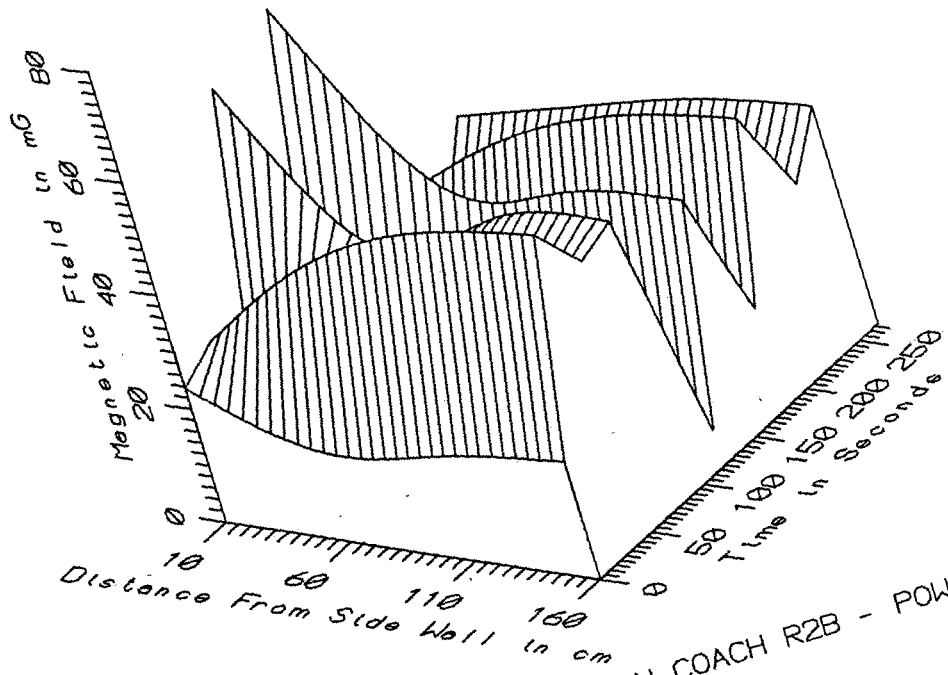

TGV013 - ABOVE SEATS 42 & 43 IN COACH R2B - POWER FREQ. 50-60Hz

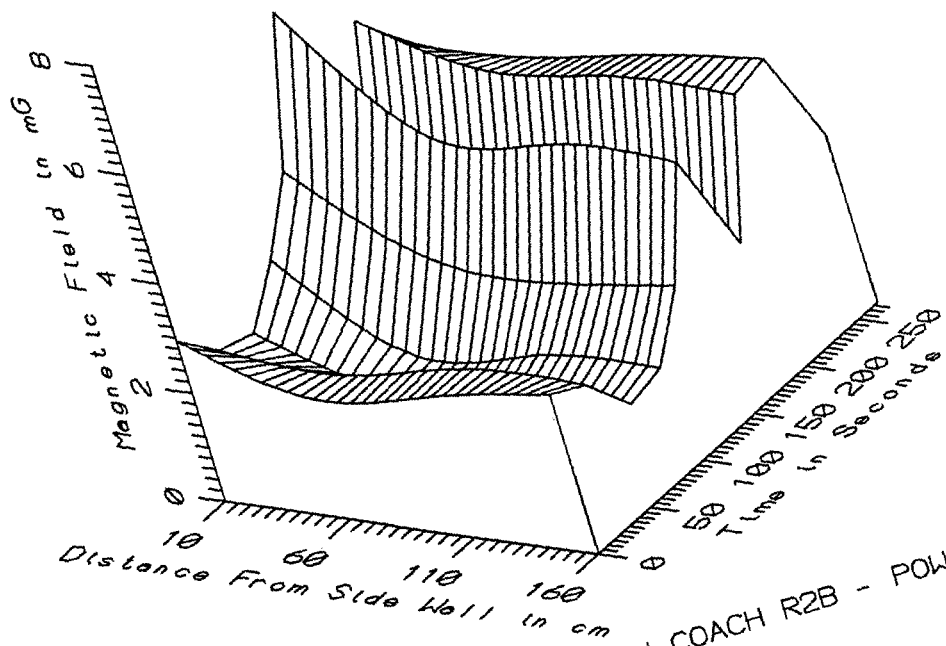

TGV013 - ABOVE SEATS 42 & 43 IN COACH R2B - POWER HARM. 65-300Hz

TGN013 - ABOVE SEATS 42 & 43 IN COACH R2B - ALL FREQ. 5-2560Hz

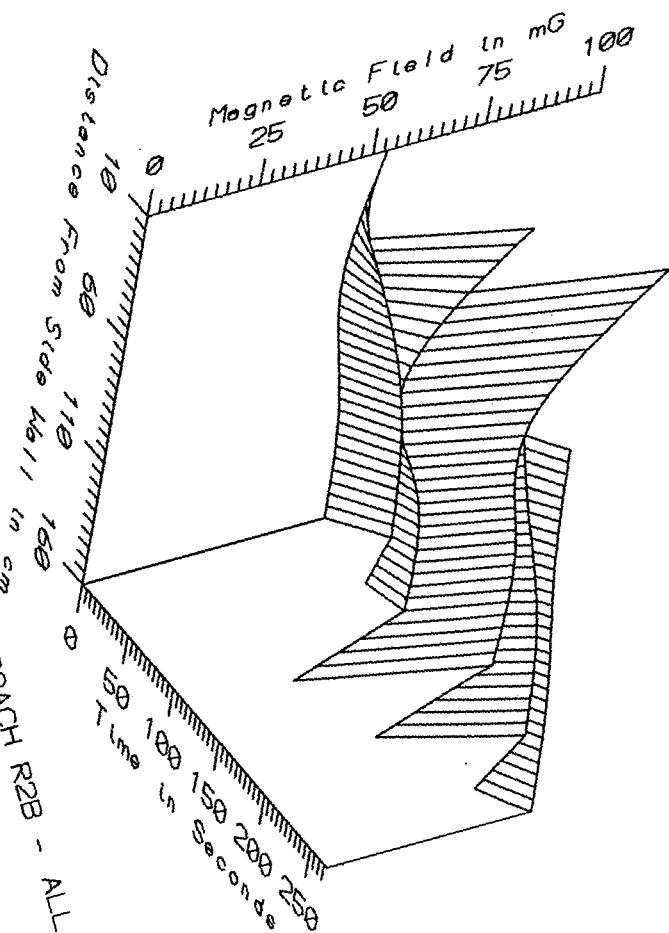



TGN013 - ABOVE SEATS 42 & 43 IN COACH R2B - HIGH FREQ. 305-2560HZ

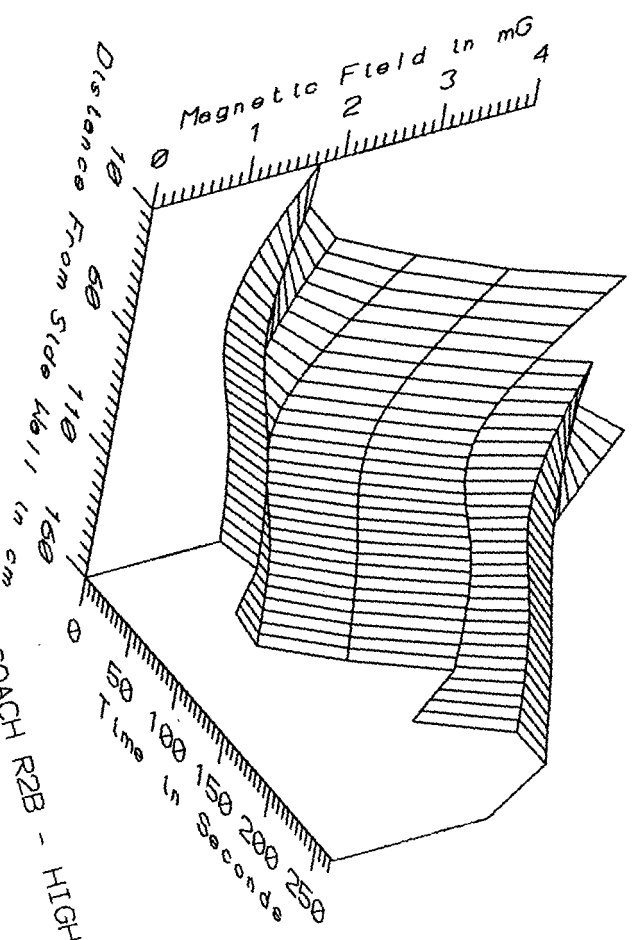

TGV013 - ALL SAMPLES IN AC SECTION				TOTAL OF 10 SAMPLES		
FREQUENCY BAND	DIST. FROM WALL (cm)	MINIMUM MAGNETIC FIELD (mG)	MAXIMUM MAGNETIC FIELD (mG)	AVERAGE MAGNETIC FIELD (mG)	STANDARD DEVIATION (mG)	COEFFICIENT OF VARIATION (%)
STATIC	10	340.42	377.08	356.80	12.07	3.38
	60	385.48	441.90	411.93	19.34	4.69
	110	450.76	491.18	470.97	13.81	2.93
	160	591.59	640.80	615.35	17.17	2.79
5-45Hz LOW FREQ	10	19.96	52.46	31.18	10.63	34.10
	60	19.74	45.66	28.13	9.74	34.64
	110	21.01	49.09	29.29	10.28	35.11
	160	21.94	49.85	29.53	9.86	33.38
50-60Hz PWR FREQ	10	9.99	66.43	30.50	18.66	61.18
	60	10.21	43.76	28.10	12.11	43.10
	110	7.51	52.63	32.94	14.86	45.10
	160	6.30	55.58	34.97	15.84	45.29
65-300Hz PWR HARM	10	2.05	6.38	3.52	1.43	40.60
	60	1.35	4.61	2.79	1.25	44.84
	110	1.53	4.87	3.04	1.24	40.93
	160	1.78	5.01	3.26	1.18	36.26
305-2560Hz HIGH FREQ	10	1.34	3.53	2.12	0.68	31.87
	60	0.70	2.20	1.42	0.59	41.67
	110	0.83	2.39	1.57	0.59	37.91
	160	0.93	2.50	1.71	0.58	33.79
5-2560Hz ALL FREQ	10	26.28	84.96	45.10	18.35	40.68
	60	23.46	59.47	41.05	11.78	28.69
	110	23.14	61.27	45.75	13.22	28.89
	160	23.07	62.98	47.56	13.38	28.13

APPENDIX O

DATASET TGV014  
AXIAL PROFILE FROM CENTER OF FIRST CLASS COACH R2B

Measurement Setup Code:        Staff: 15        Reference: 16  
   Drawing: A-1

Vehicle Status:                Coach trip from Montparnasse  
   station in Paris to Vendome station

Measurement Date:              September 8, 1992

Measurement Time:              Start:        14:27:43  
   End:         14:32:02

Number of Samples:             10

Programmed Sample Interval:   30 sec

Actual Sample Interval:        28.8 sec

Frequency Spectrum Parameters

<u>Probe Type:</u>	<u>Wideband</u>	<u>Static</u>
Maximum Frequency (Hz)	2560	64
Minimum Frequency (Hz)	5	0
Spectral Bandwidth (Hz)	5	1

Missing or Suspect Data:        None

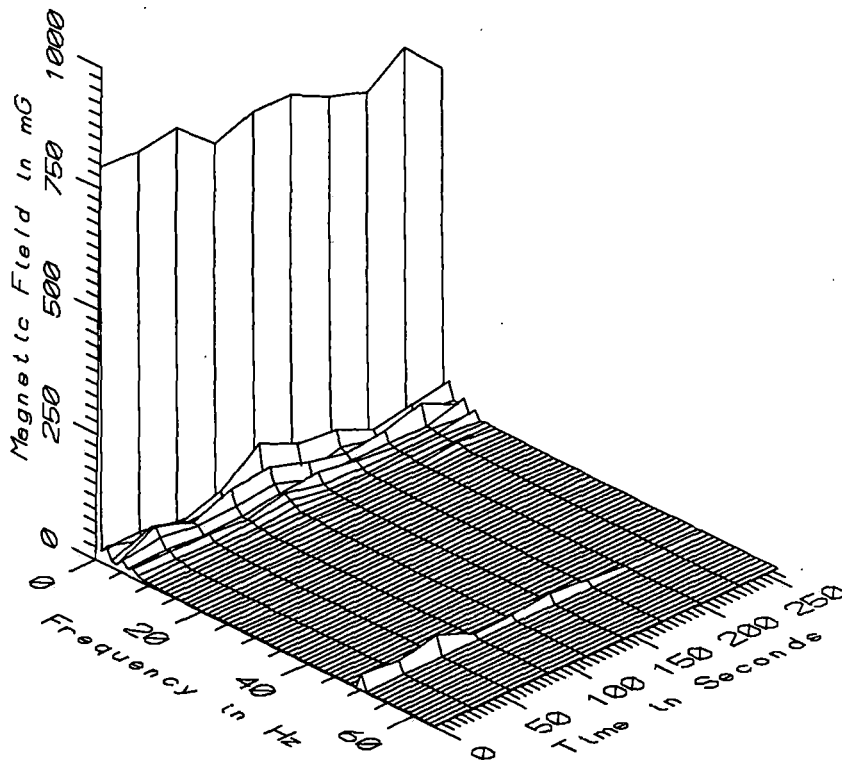

TGV014 - 10cm FROM CENTER LINE BETWEEN SEATS 41 & 42 IN COACH R2B

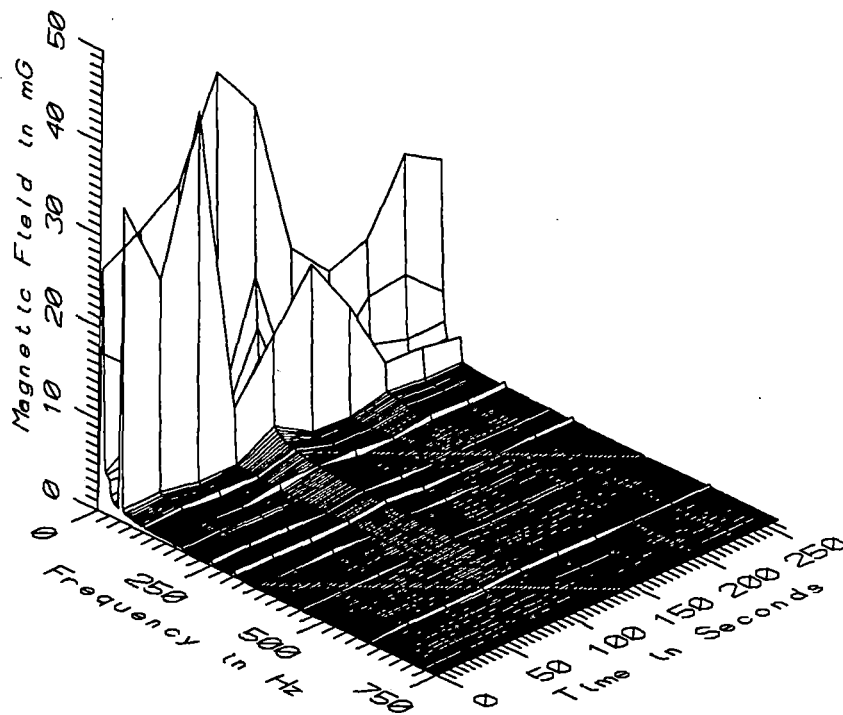

TGV014 - 10cm FROM CENTER LINE BETWEEN SEATS 41 & 42 IN COACH R2B

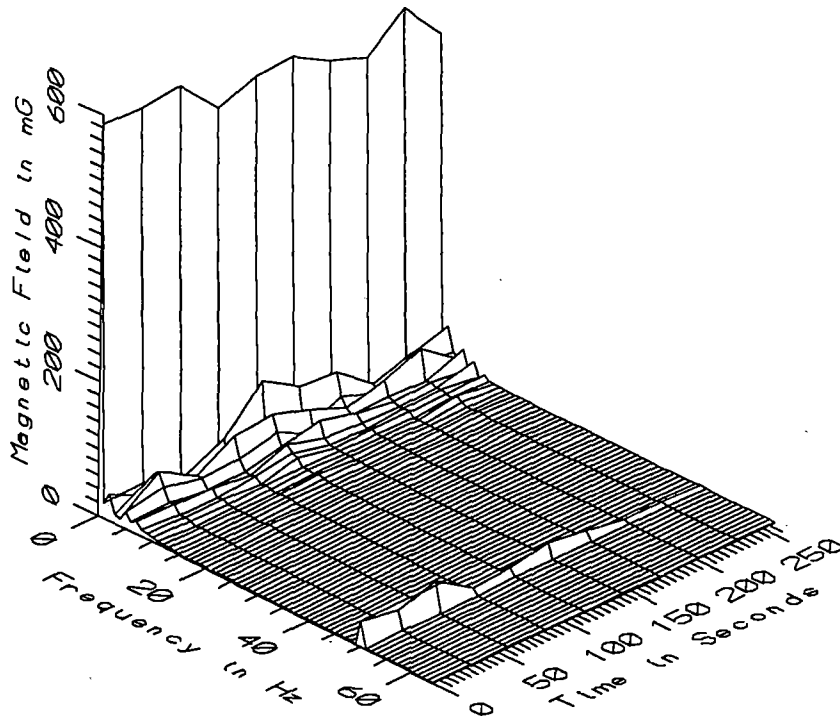

TGV014 - 60cm FROM CENTER LINE BETWEEN SEATS 41 & 42 IN COACH R2B

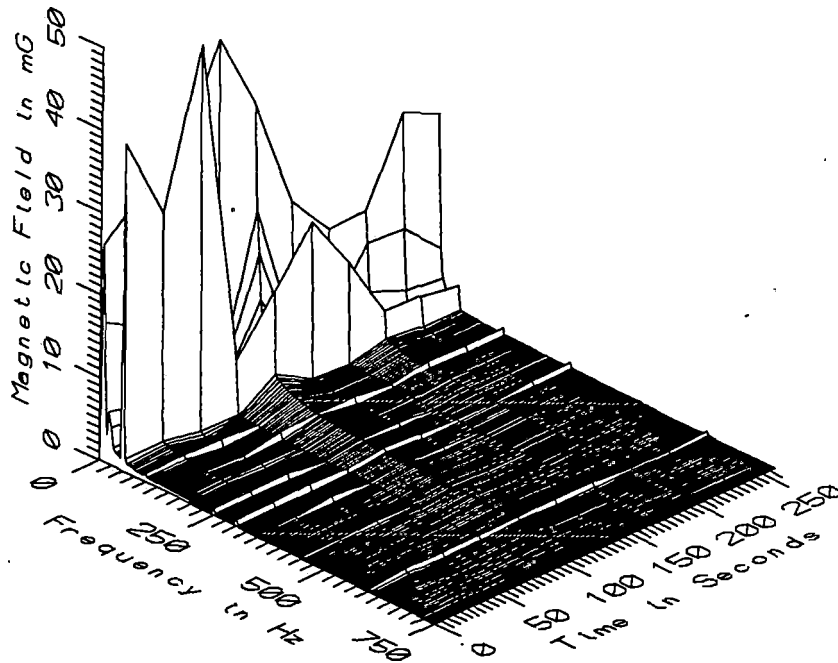

TGV014 - 60cm FROM CENTER LINE BETWEEN SEATS 41 & 42 IN COACH R2B

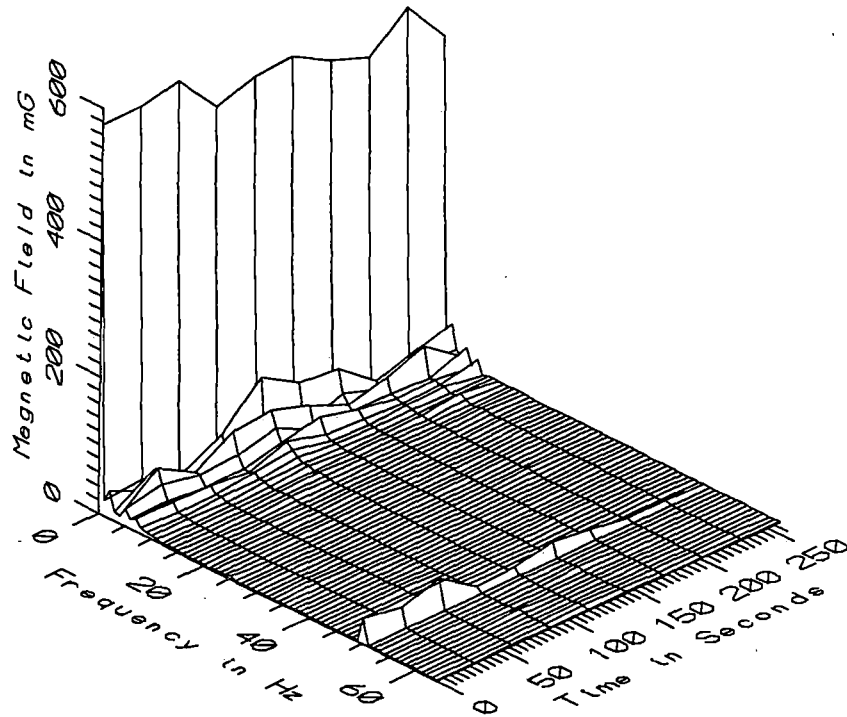

TGV014 - 110cm FROM CENTER LINE BETWEEN SEATS 41 & 42 IN COACH R2B

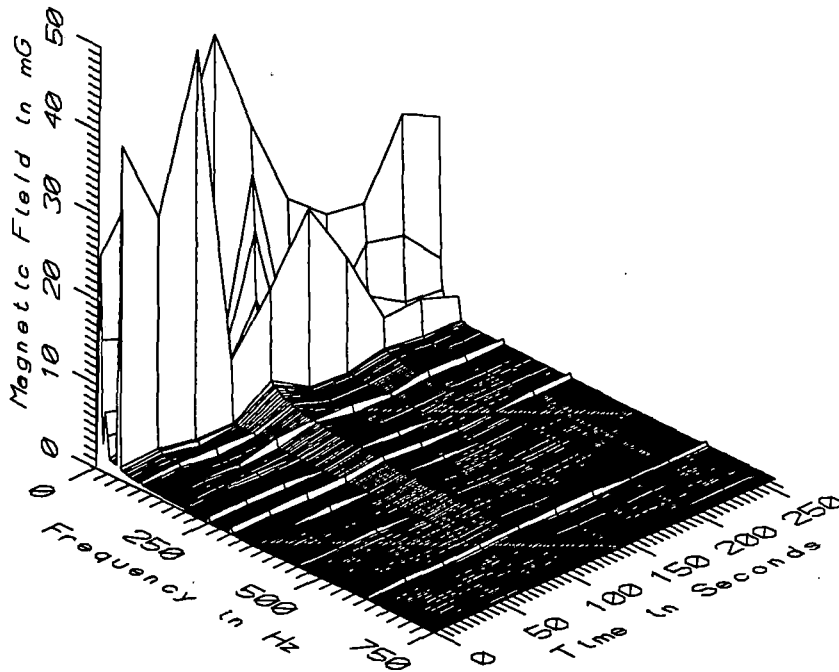

TGV014 - 110cm FROM CENTER LINE BETWEEN SEATS 41 & 42 IN COACH R2B

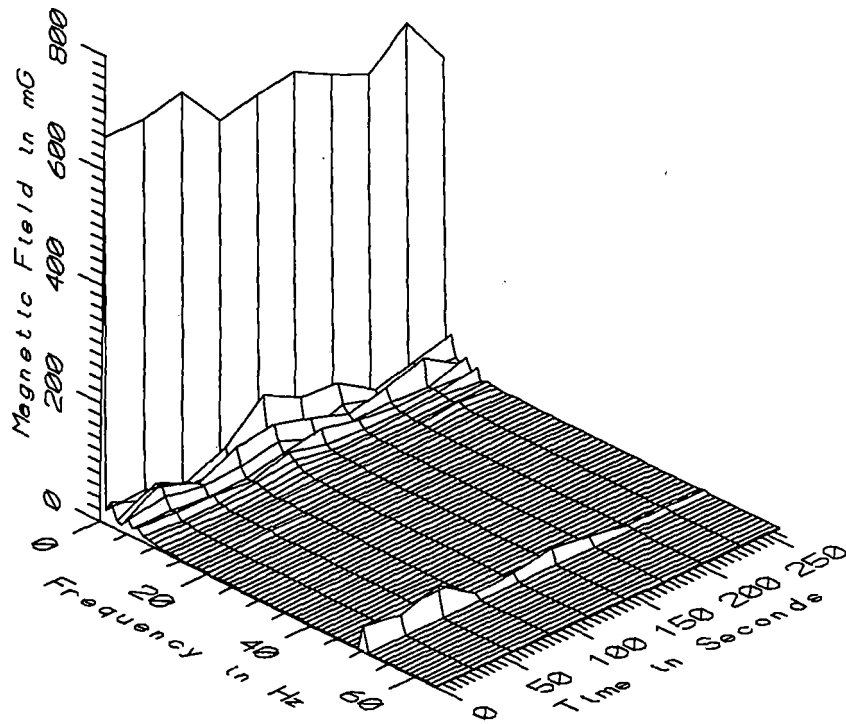

TGV014 - 160cm FROM CENTER LINE BETWEEN SEATS 41 & 42 IN COACH R2B

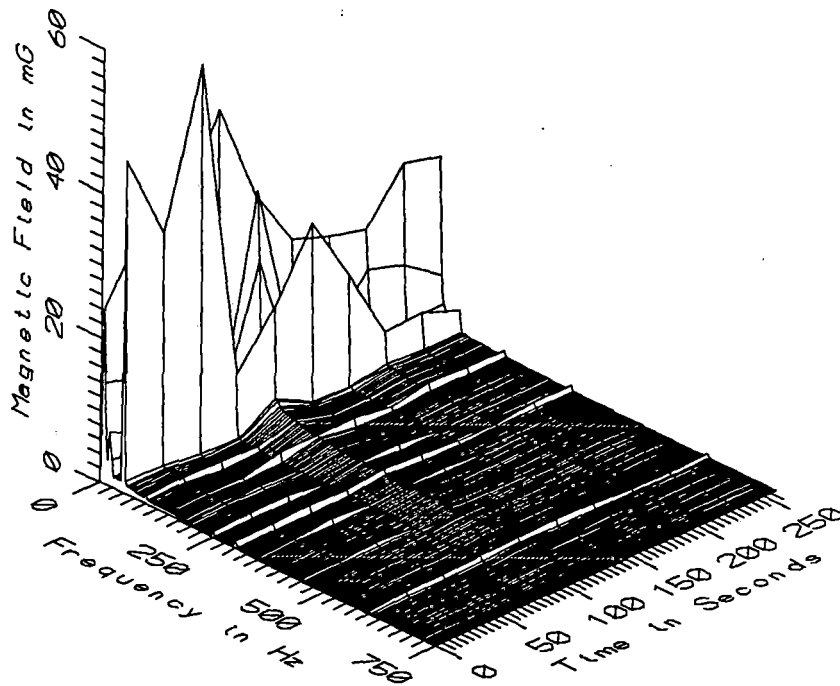

TGV014 - 160cm FROM CENTER LINE BETWEEN SEATS 41 & 42 IN COACH R2B

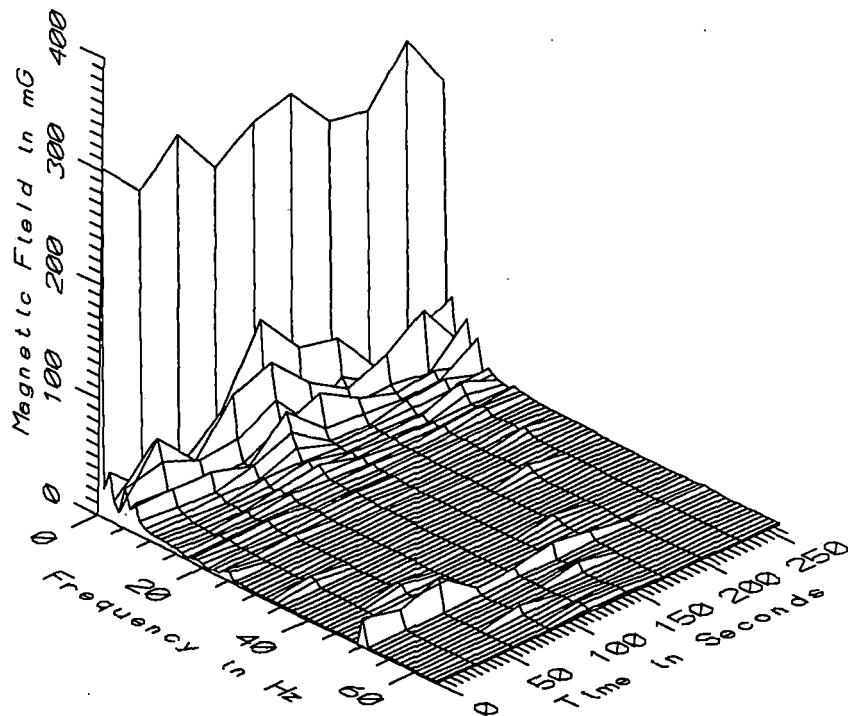

TGV014 - REFERENCE PROBE - ON MIDDLE SEAT IN COACH R2B

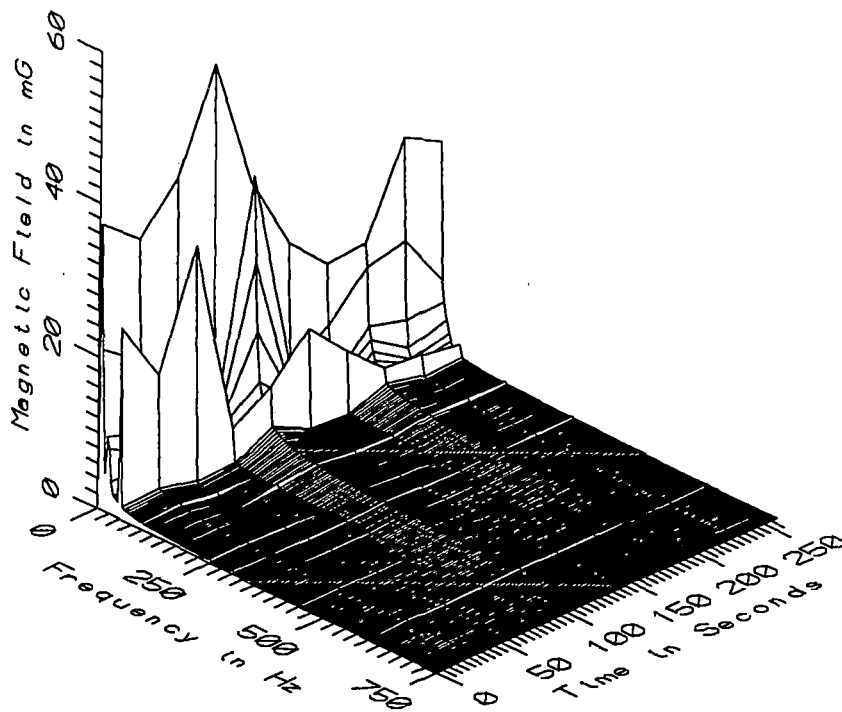

TGV014 - REFERENCE PROBE - ON MIDDLE SEAT IN COACH R2B



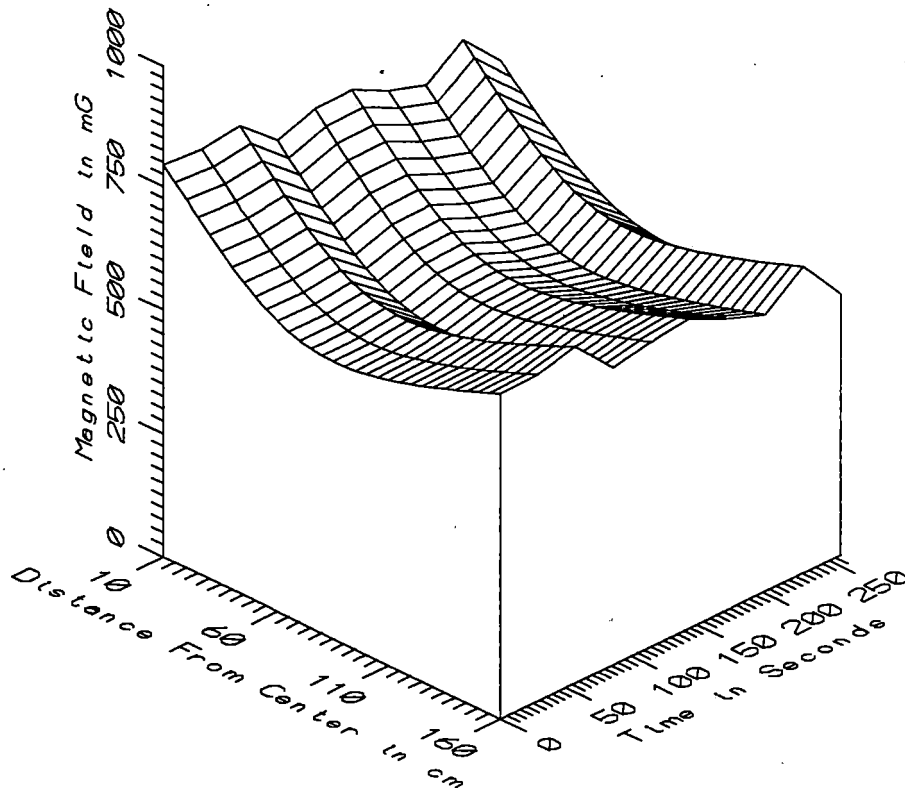

TGV014 - AXIAL PROFILE FROM CENTER OF COACH R2B - STATIC

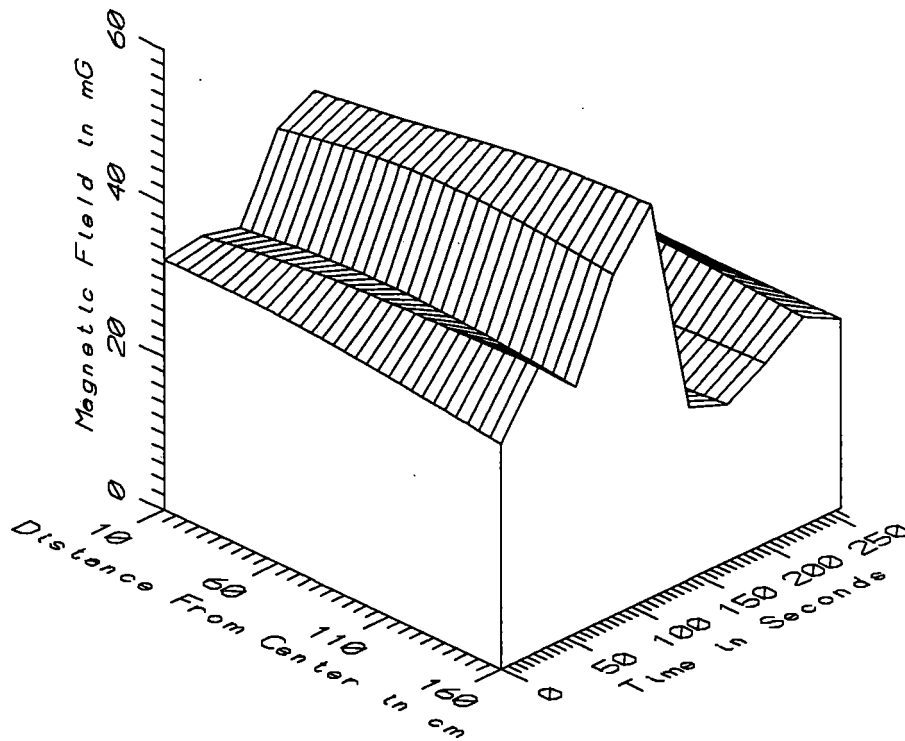

TGV014 - AXIAL PROFILE FROM CENTER OF COACH R2B - LOW FREQ, 5-45Hz

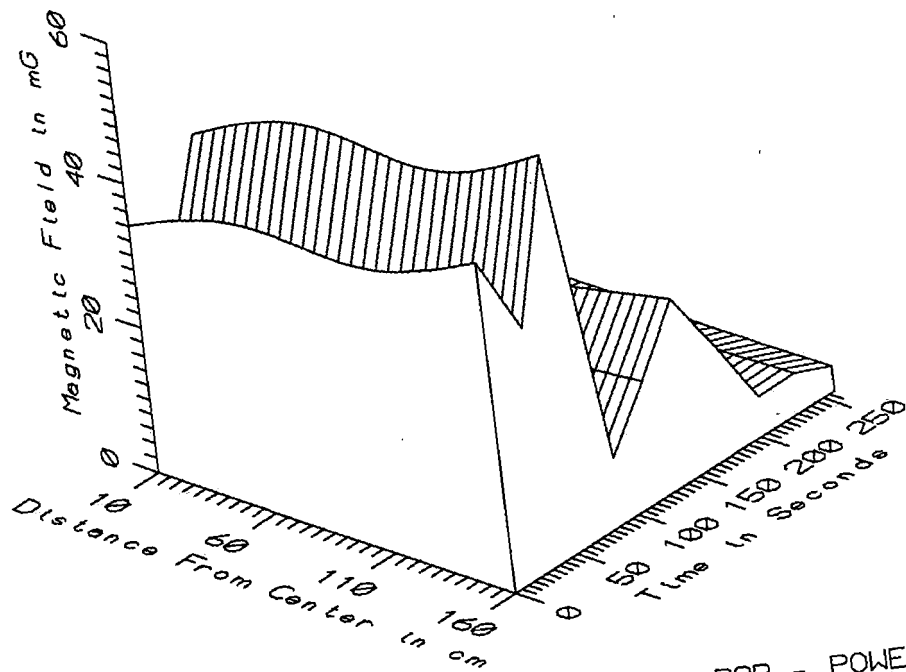

TGV014 - AXIAL PROFILE FROM CENTER OF COACH R2B - POWER FREQ. 50-60Hz

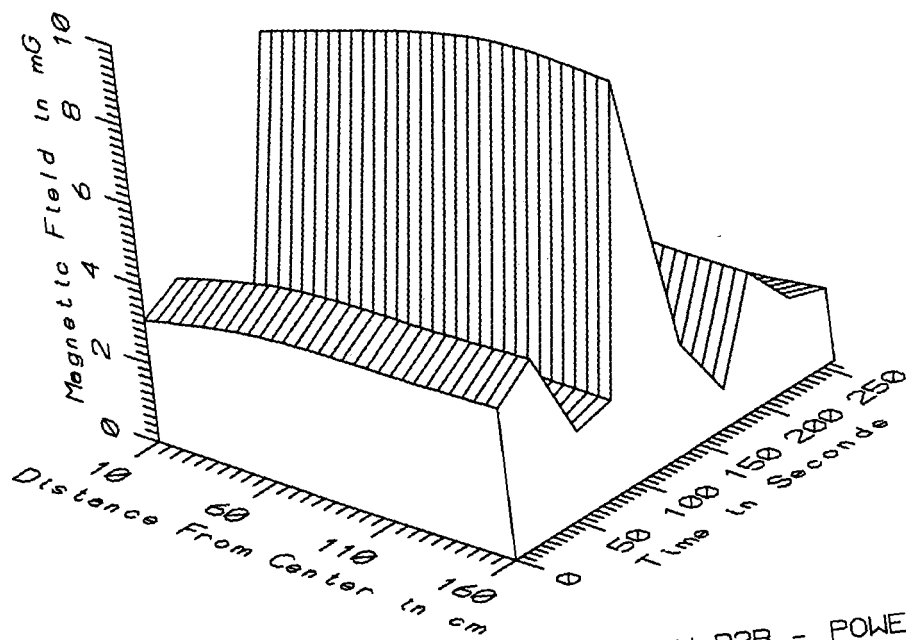

TGV014 - AXIAL PROFILE FROM CENTER OF COACH R2B - POWER HARM, 65-300Hz

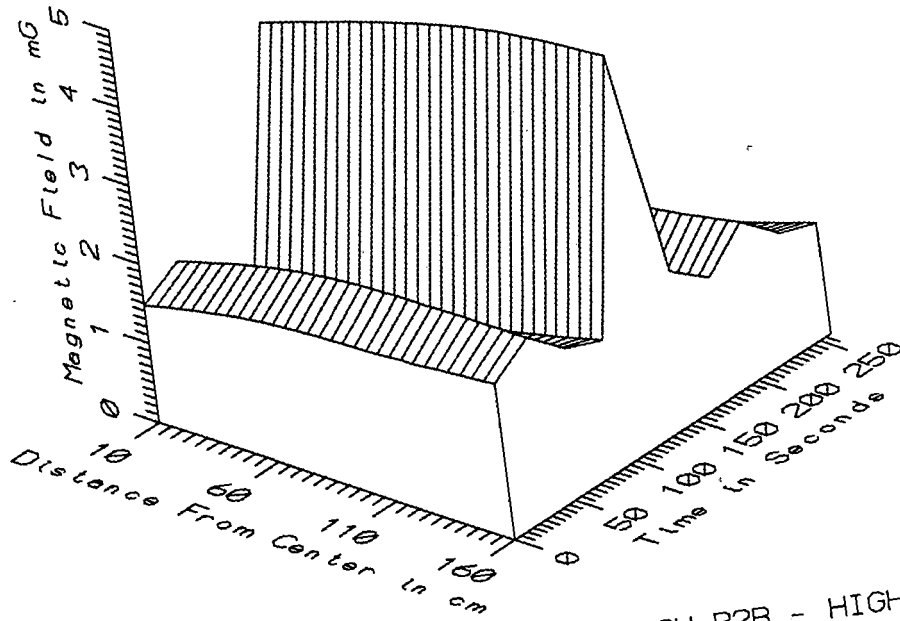

TGV014 - AXIAL PROFILE FROM CENTER OF COACH R2B - HIGH FREQ. 305-2560Hz

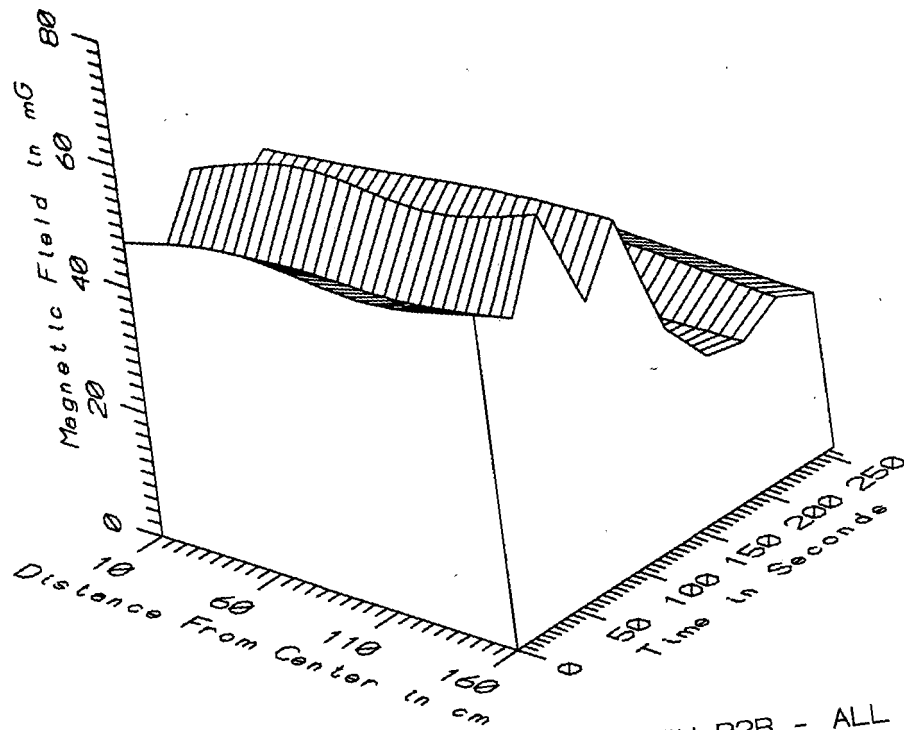

TGV014 - AXIAL PROFILE FROM CENTER OF COACH R2B - ALL FREQ. 5-2560Hz

TGV014 - ALL SAMPLES IN AC SECTION			TOTAL OF 10 SAMPLES			
FREQUENCY BAND	DIST. FROM CENTER (cm)	MINIMUM MAGNETIC FIELD (mG)	MAXIMUM MAGNETIC FIELD (mG)	AVERAGE MAGNETIC FIELD (mG)	STANDARD DEVIATION (mG)	COEFFICIENT OF VARIATION (%)
STATIC	10	684.28	803.54	754.54	39.44	5.23
	60	491.57	593.18	549.86	34.14	6.21
	110	477.82	588.57	540.18	35.74	6.62
	160	529.17	677.81	612.96	45.94	7.49
5-45Hz LOW FREQ	10	15.94	45.09	29.20	9.69	33.17
	60	16.57	47.56	30.66	10.30	33.59
	110	18.98	50.22	31.52	10.32	32.75
	160	20.70	51.41	31.47	10.17	32.30
50-60Hz PWR FREQ	10	3.19	40.76	16.19	13.20	81.51
	60	3.35	47.52	18.20	15.69	86.19
	110	3.23	46.92	18.77	15.31	81.56
	160	3.47	54.50	21.59	17.88	82.83
65-300Hz PWR HARM	10	0.85	8.10	2.77	2.07	74.80
	60	0.94	9.14	3.11	2.37	76.03
	110	1.01	9.91	3.24	2.58	79.51
	160	0.98	9.91	3.41	2.51	73.75
305-2560Hz HIGH FREQ	10	0.69	3.94	1.40	0.96	68.51
	60	0.78	4.44	1.60	1.09	67.69
	110	0.95	4.82	1.79	1.14	63.83
	160	1.40	4.98	2.12	1.04	49.12
5-2560Hz ALL FREQ	10	19.99	51.90	35.11	12.38	35.25
	60	20.85	58.34	37.80	14.07	37.23
	110	23.59	57.82	38.83	13.58	34.99
	160	24.58	63.48	40.77	14.83	36.38

APPENDIX P

DATASET TGV015  
VENDOME STATION RELAY ROOM NEAR AC SUPPLY CABINET

Measurement Setup Code:      Staff: 17      Reference: -  
   Drawing: A-4

Vehicle Status:                      Not Applicable

Measurement Date:                    September 8, 1992

Measurement Time:                    Start:      15:08:53  
   End:        15:10:40

Number of Samples:                    12

Programmed Sample Interval:        10 sec

Actual Sample Interval:              9.7 sec

Frequency Spectrum Parameters

<u>Probe Type:</u>	<u>Wideband</u>	<u>Static</u>
Maximum Frequency (Hz)	2560	64
Minimum Frequency (Hz)	5	0
Spectral Bandwidth (Hz)	5	1

Missing or Suspect Data:            None

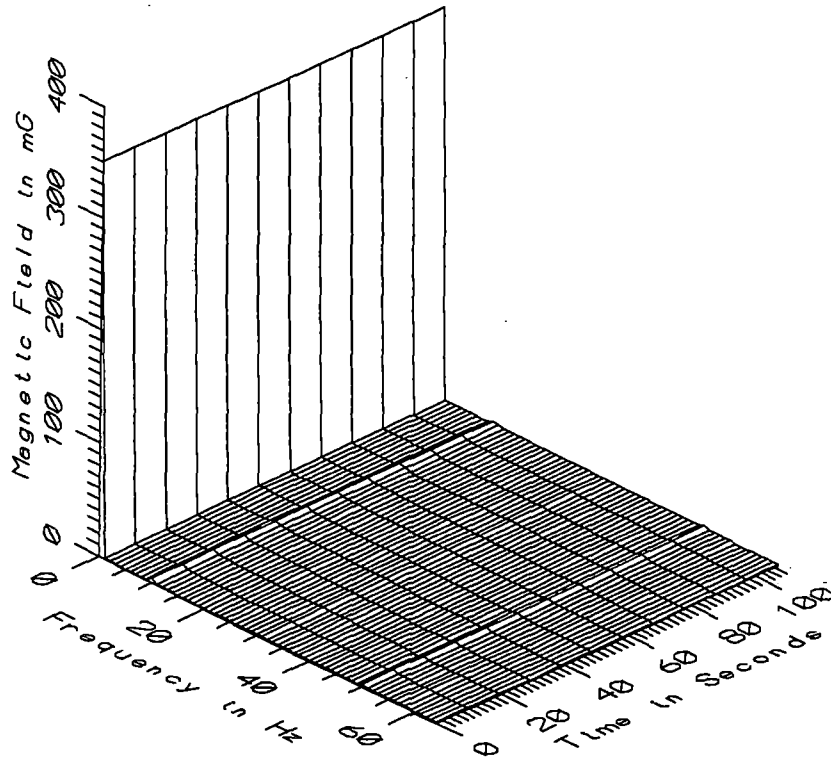

TGV015 - 10cm ABOVE FLOOR NEAR AC SUPPLY CABINET IN VENDOME RELAY ROOM

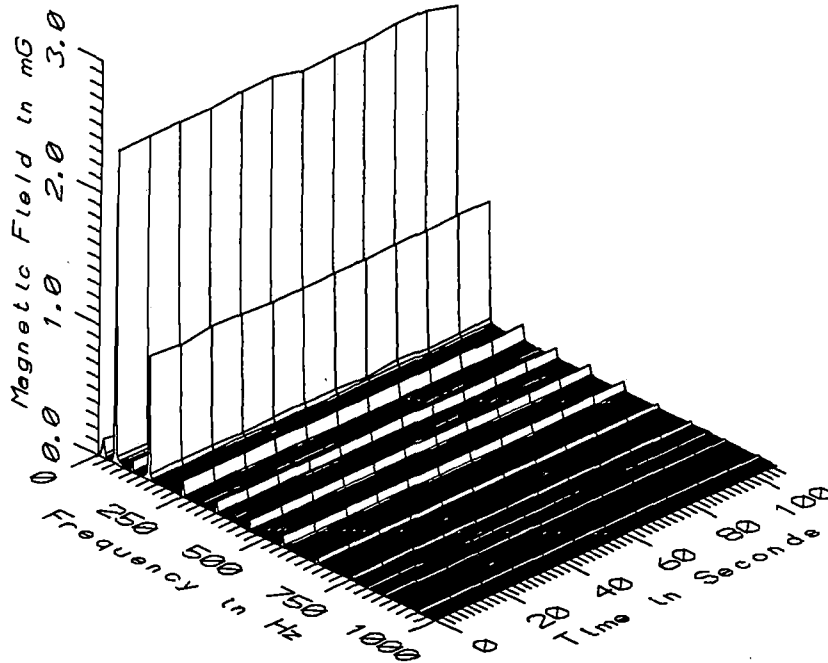

TGV015 - 10cm ABOVE FLOOR NEAR AC SUPPLY CABINET IN VENDOME RELAY ROOM

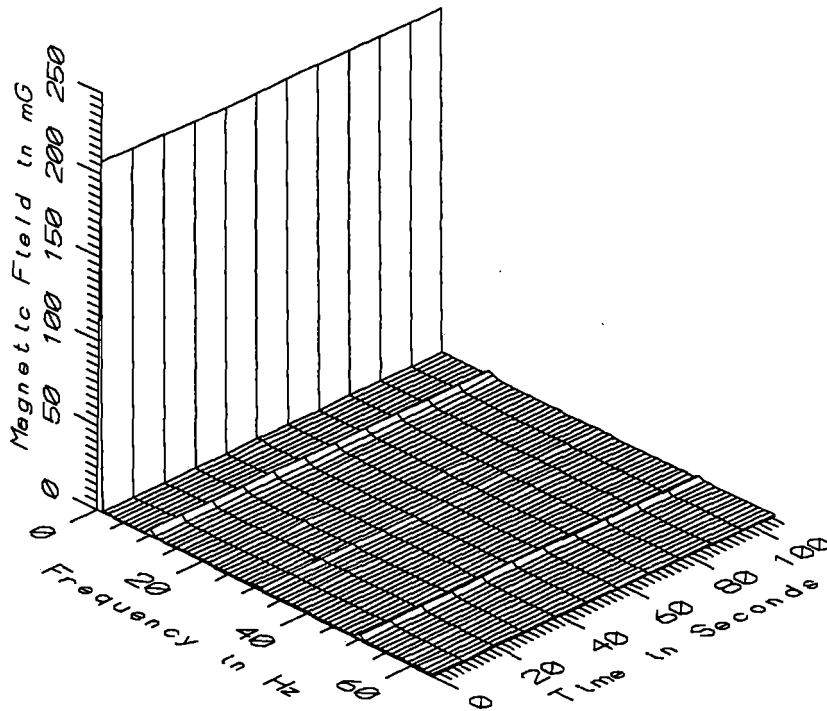

TGV015 - 60cm ABOVE FLOOR NEAR AC SUPPLY CABINET IN VENDOME RELAY ROOM

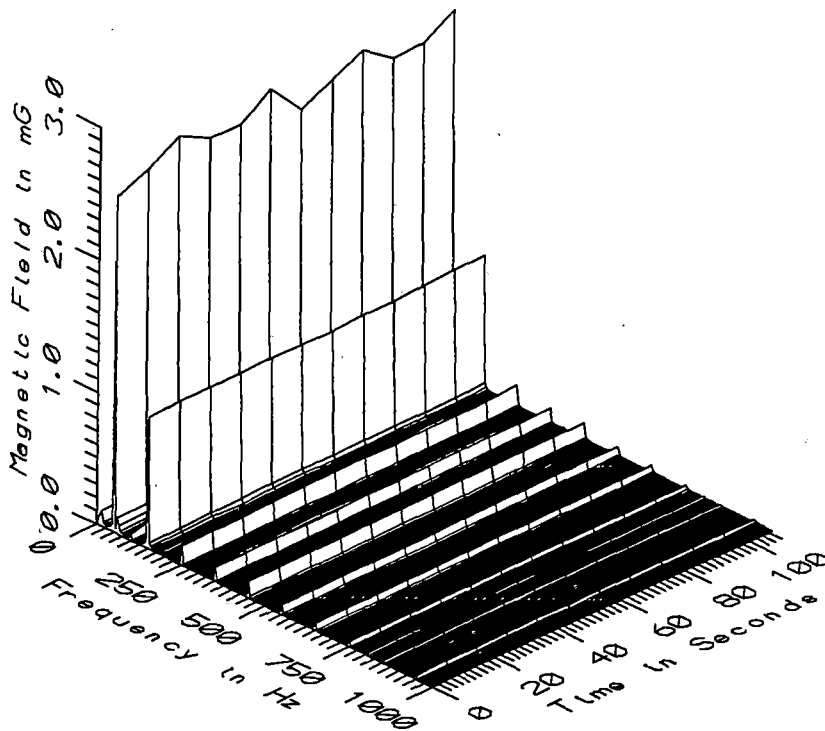

TGV015 - 60cm ABOVE FLOOR NEAR AC SUPPLY CABINET IN VENDOME RELAY ROOM

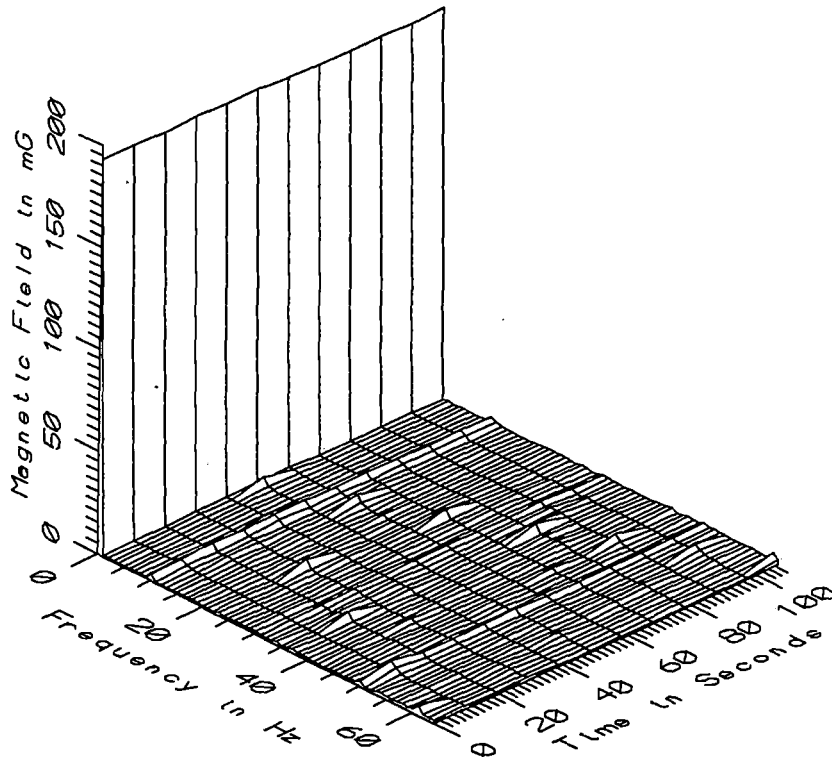

TGV015 - 110cm ABOVE FLOOR NEAR AC SUPPLY CABINET IN VENDOME RELAY ROOM

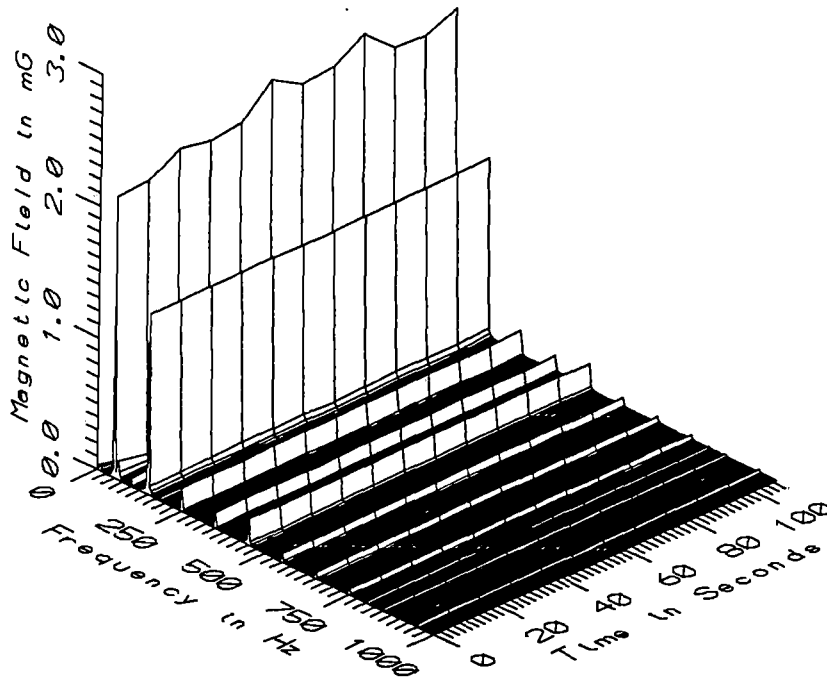

TGV015 - 110cm ABOVE FLOOR NEAR AC SUPPLY CABINET IN VENDOME RELAY ROOM



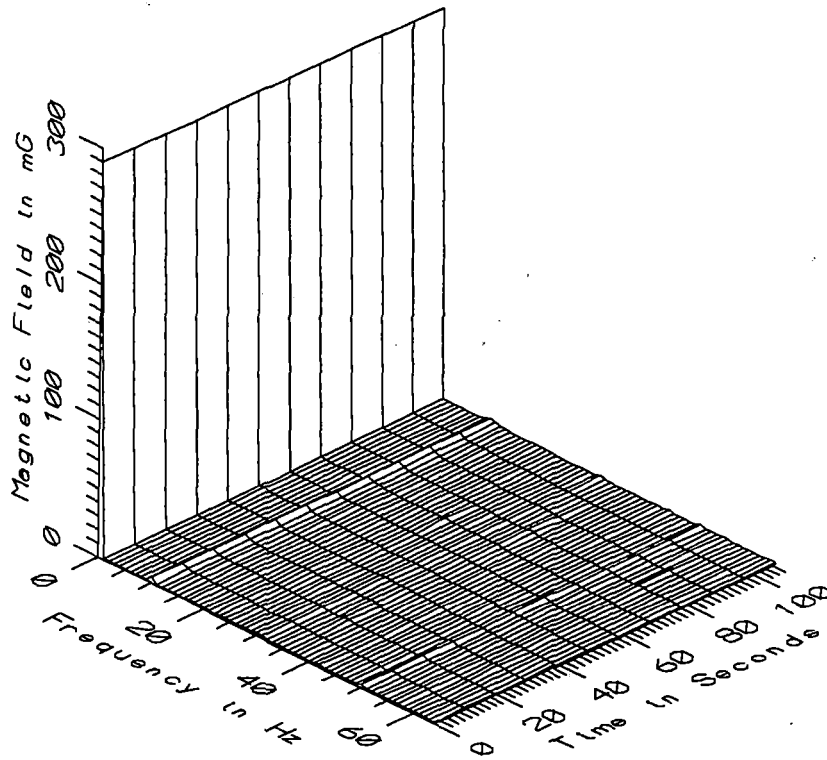

TGV015 - 160cm ABOVE FLOOR NEAR AC SUPPLY CABINET IN VENDOME RELAY ROOM

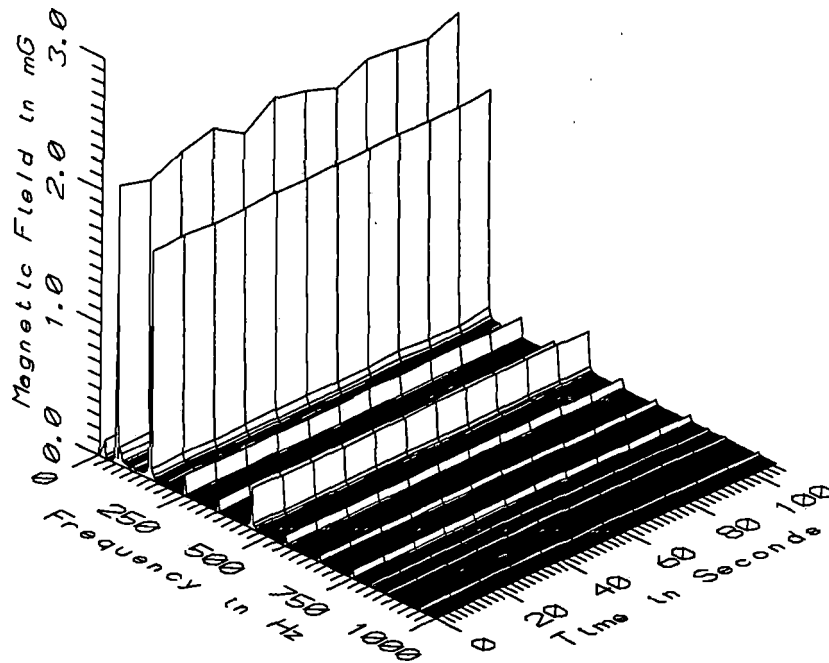

TGV015 - 160cm ABOVE FLOOR NEAR AC SUPPLY CABINET IN VENDOME RELAY ROOM

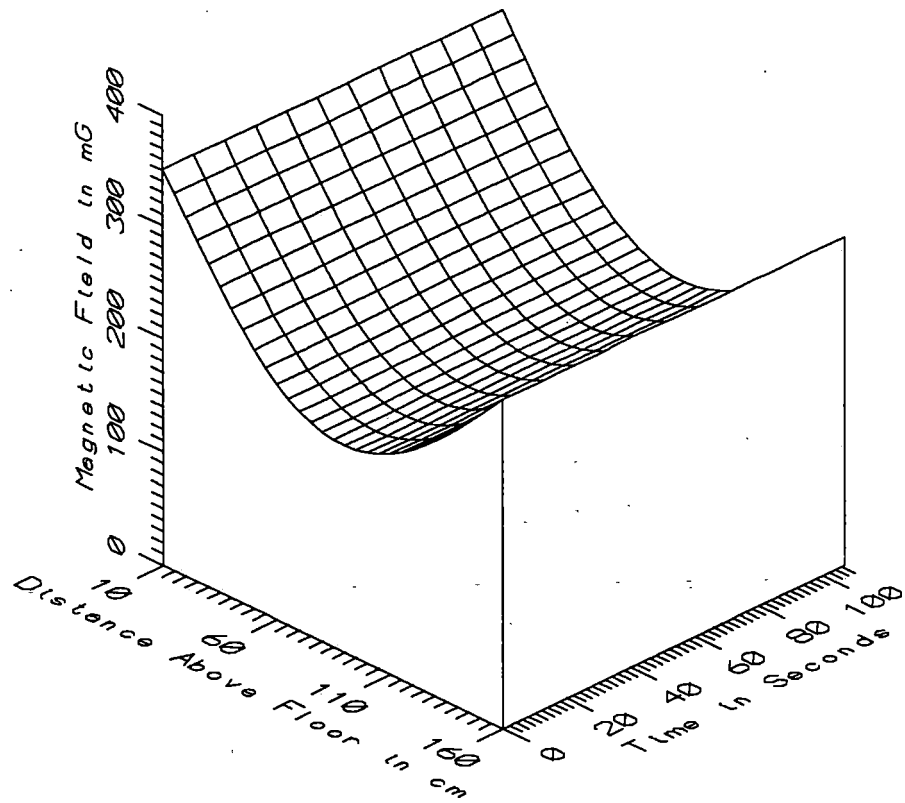

TGV015 - NEAR AC SUPPLY IN VENDOME RELAY ROOM - STATIC

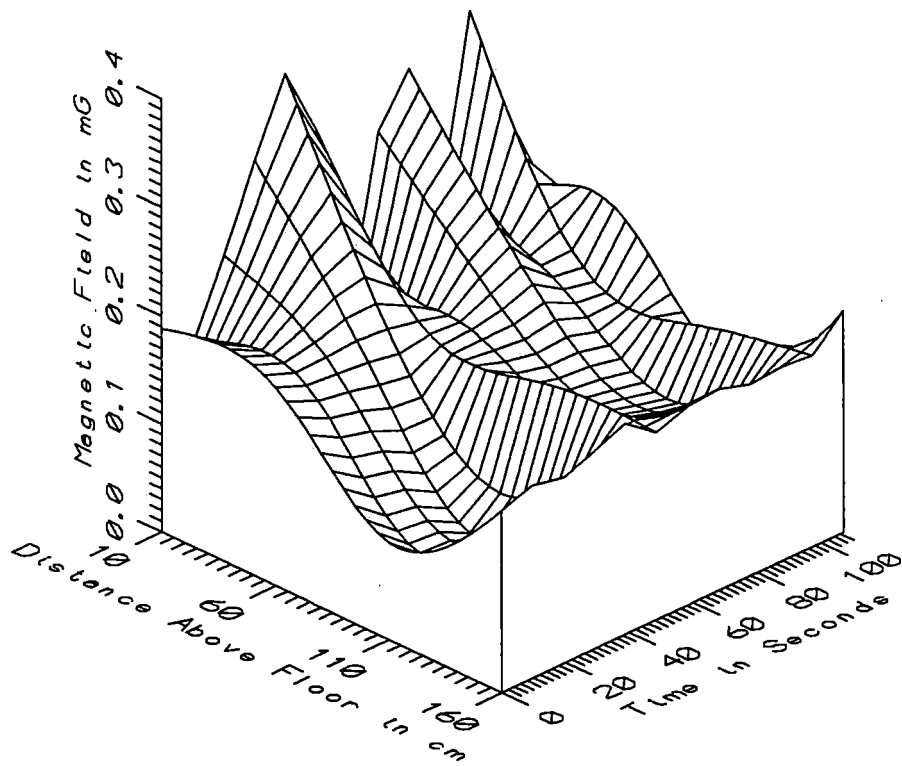

TGV015 - NEAR AC SUPPLY IN VENDOME RELAY ROOM - LOW FREQ, 5-45Hz

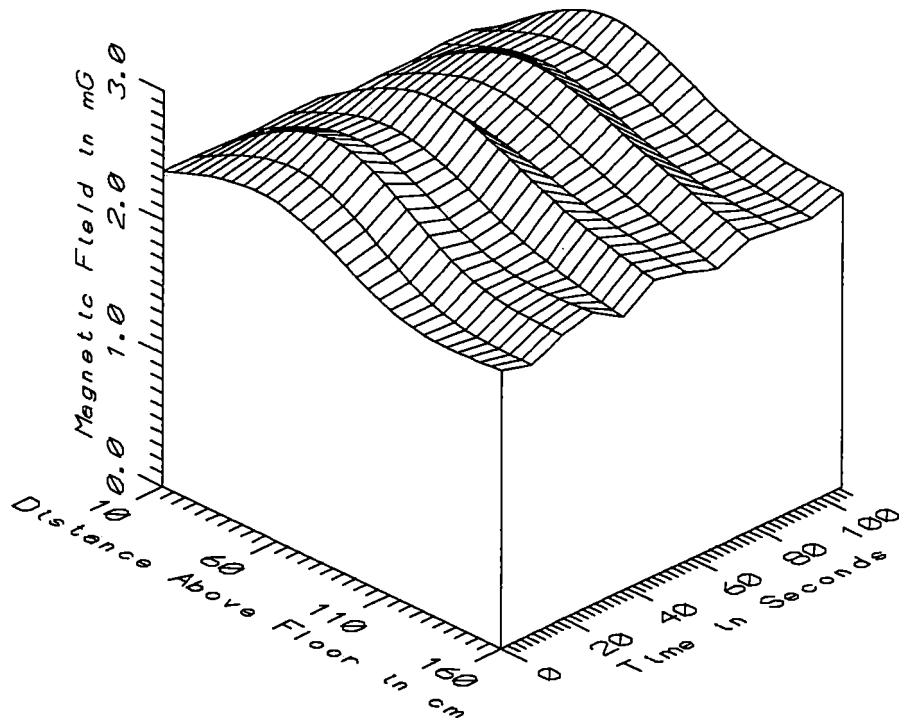

TGV015 - NEAR AC SUPPLY IN VENDOME RELAY ROOM - POWER FREQ, 50-60Hz

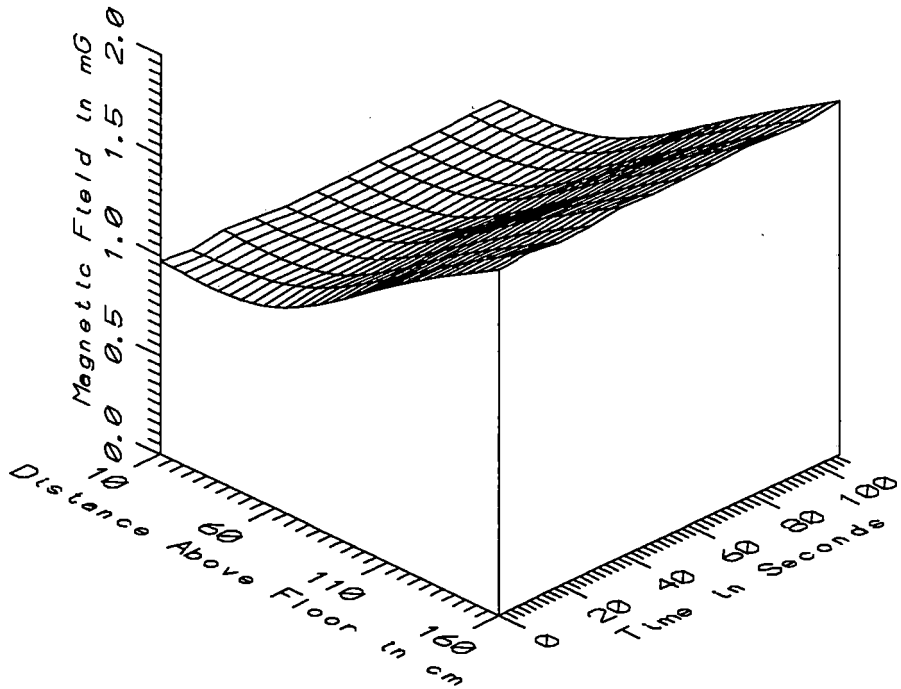

TGV015 - NEAR AC SUPPLY IN VENDOME RELAY ROOM - POWER HARM, 65-300Hz

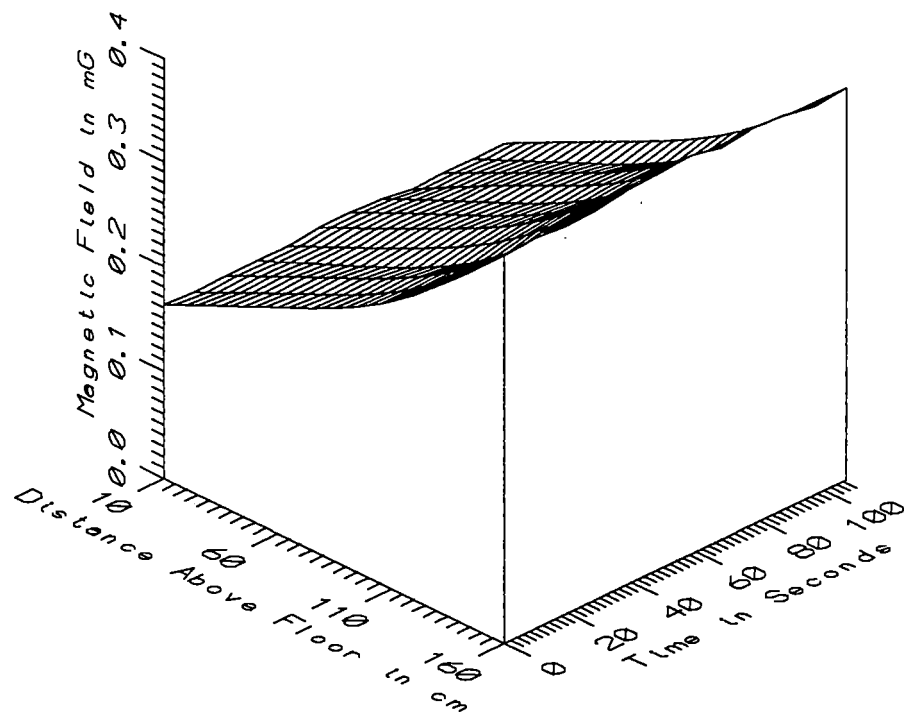

TGV015 - NEAR AC SUPPLY IN VENDOME RELAY ROOM - HIGH FREQ, 305-2560Hz

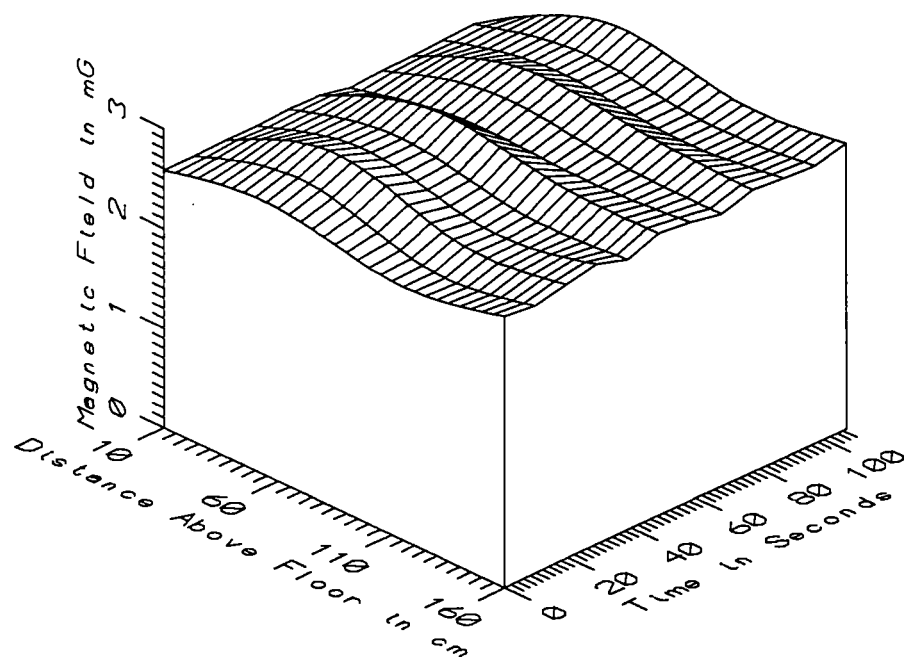

TGV015 - NEAR AC SUPPLY IN VENDOME RELAY ROOM - ALL FREQ, 5-2560Hz

TGV015 - VENDOME RELAY ROOM, NEAR AC SUPPLY CABINET					TOTAL OF 12 SAMPLES	
FREQUENCY BAND	HEIGHT ABOVE FLOOR (cm)	MINIMUM MAGNETIC FIELD (mG)	MAXIMUM MAGNETIC FIELD (mG)	AVERAGE MAGNETIC FIELD (mG)	STANDARD DEVIATION (mG)	COEFFICIENT OF VARIATION (%)
STATIC	10	350.67	351.26	350.97	0.22	0.06
	60	207.05	207.79	207.45	0.24	0.12
	110	192.74	193.79	193.33	0.36	0.19
	160	289.08	290.45	289.71	0.47	0.16
5-45Hz LOW FREQ	10	0.12	0.37	0.24	0.08	34.29
	60	0.16	0.20	0.17	0.01	7.31
	110	0.05	0.17	0.10	0.04	34.75
	160	0.17	0.21	0.18	0.01	5.48
50-60Hz PWR FREQ	10	2.29	2.40	2.36	0.03	1.24
	60	2.54	2.81	2.67	0.09	3.40
	110	2.14	2.52	2.32	0.12	4.97
	160	2.03	2.22	2.14	0.06	2.96
65-300Hz PWR HARM	10	0.95	0.98	0.96	0.01	1.06
	60	1.02	1.05	1.03	0.01	0.92
	110	1.38	1.40	1.39	0.01	0.42
	160	1.74	1.77	1.76	0.01	0.62
305-2560Hz HIGH FREQ	10	0.16	0.17	0.16	0.00	1.47
	60	0.21	0.22	0.21	0.00	1.50
	110	0.27	0.28	0.27	0.00	1.36
	160	0.37	0.38	0.37	0.00	1.04
5-2560Hz ALL FREQ	10	2.50	2.61	2.57	0.03	1.23
	60	2.75	3.00	2.87	0.09	2.97
	110	2.57	2.90	2.72	0.10	3.69
	160	2.72	2.87	2.80	0.05	1.75

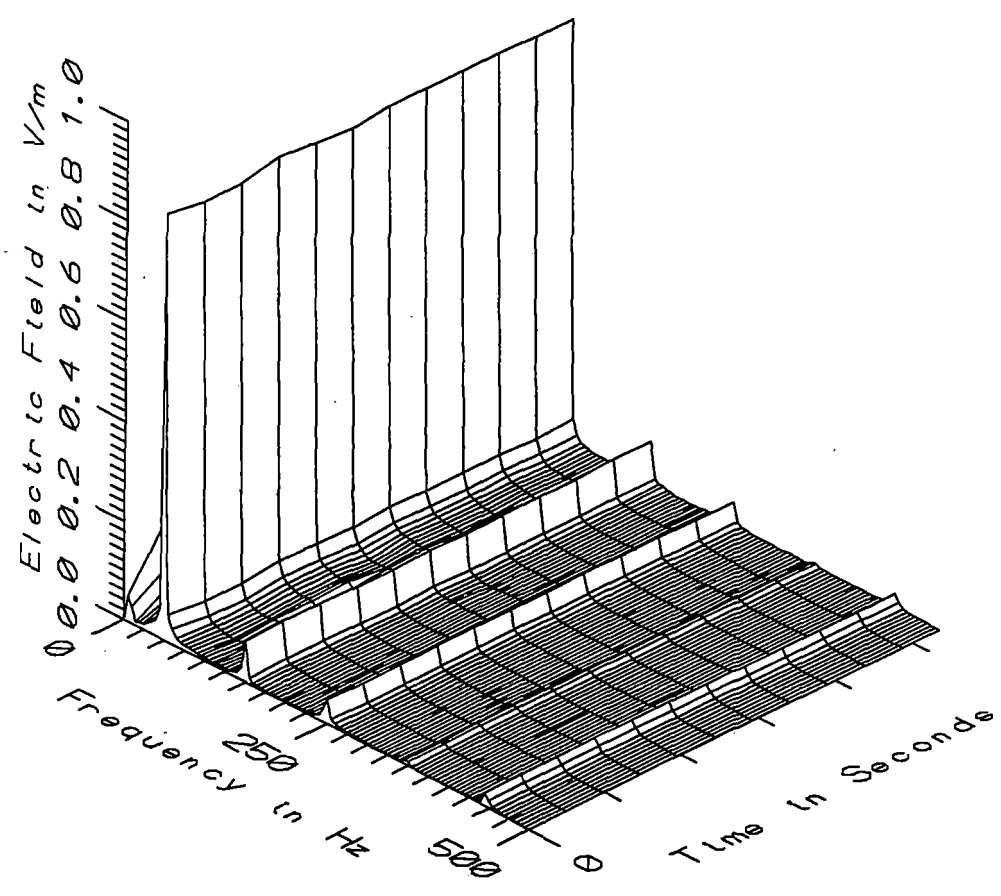

TGV015 - ELECTRIC FIELD IN VENDOME RELAY ROOM

APPENDIX Q

DATASET TGV016

VENDOME STATION RELAY ROOM BETWEEN TWO ROWS OF RELAY SHELVES

Measurement Setup Code:        Staff: 18        Reference: -  
   Drawing: A-4

Vehicle Status:                Not Applicable

Measurement Date:              September 8, 1992

Measurement Time:              Start:        15:14:42  
   End:         15:16:30

Number of Samples:             12

Programmed Sample Interval:   10 sec

Actual Sample Interval:        9.8 sec

Frequency Spectrum Parameters

<u>Probe Type:</u>	<u>Wideband</u>	<u>Static</u>
Maximum Frequency (Hz)	2560	64
Minimum Frequency (Hz)	5	0
Spectral Bandwidth (Hz)	5	1

Missing or Suspect Data:        None

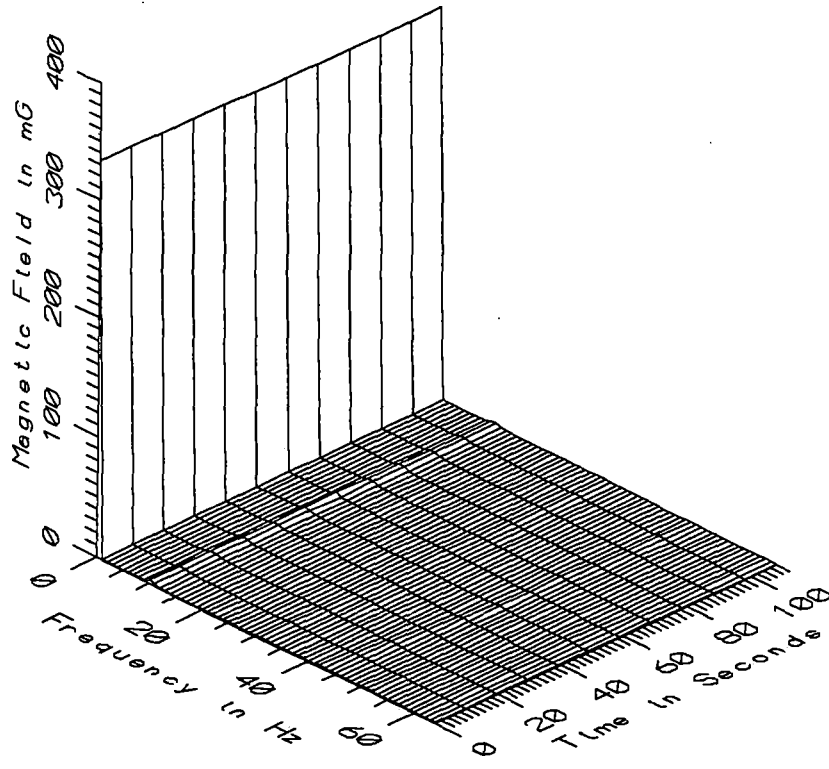

TGV016 - 10cm ABOVE FLOOR BETWEEN RELAY SHELVES, VENDOME RELAY ROOM

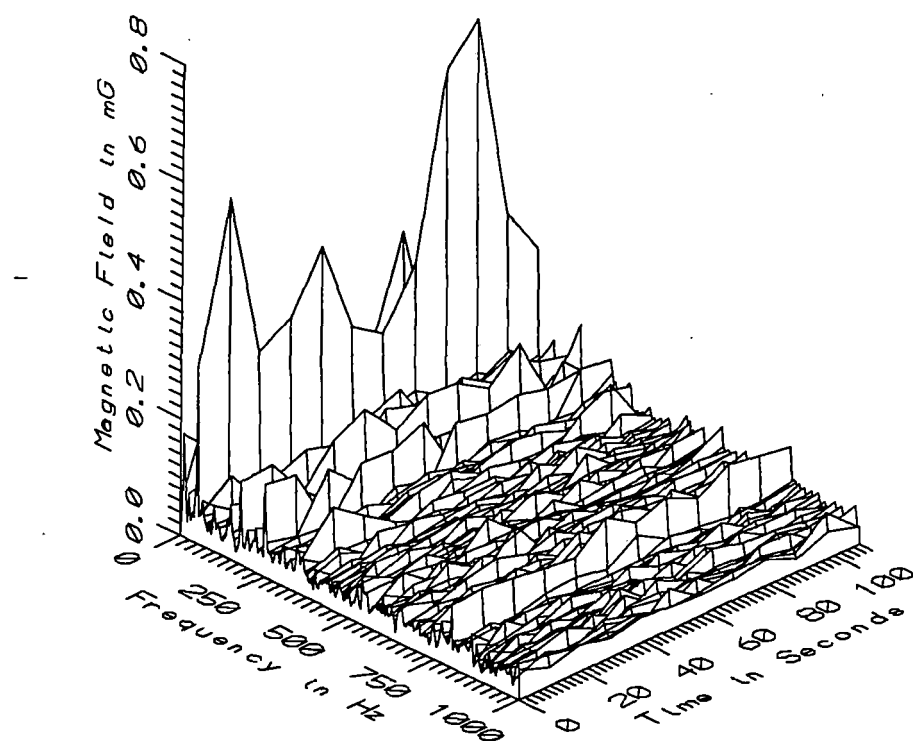

TGV016 - 10cm ABOVE FLOOR BETWEEN RELAY SHELVES, VENDOME RELAY ROOM



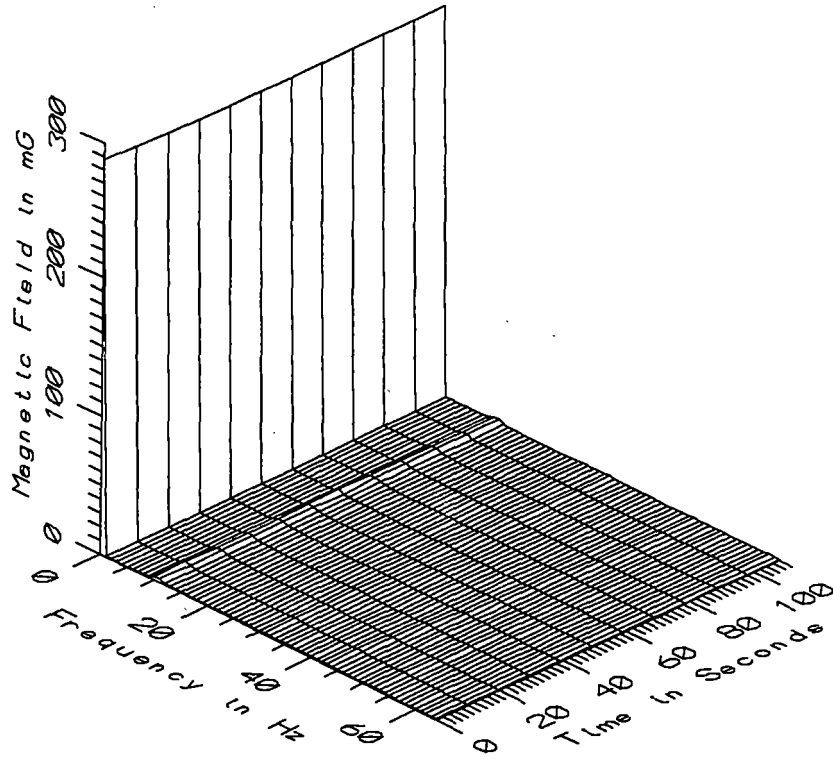

TGV016 - 60cm ABOVE FLOOR BETWEEN RELAY SHELVES, VENDOME RELAY ROOM

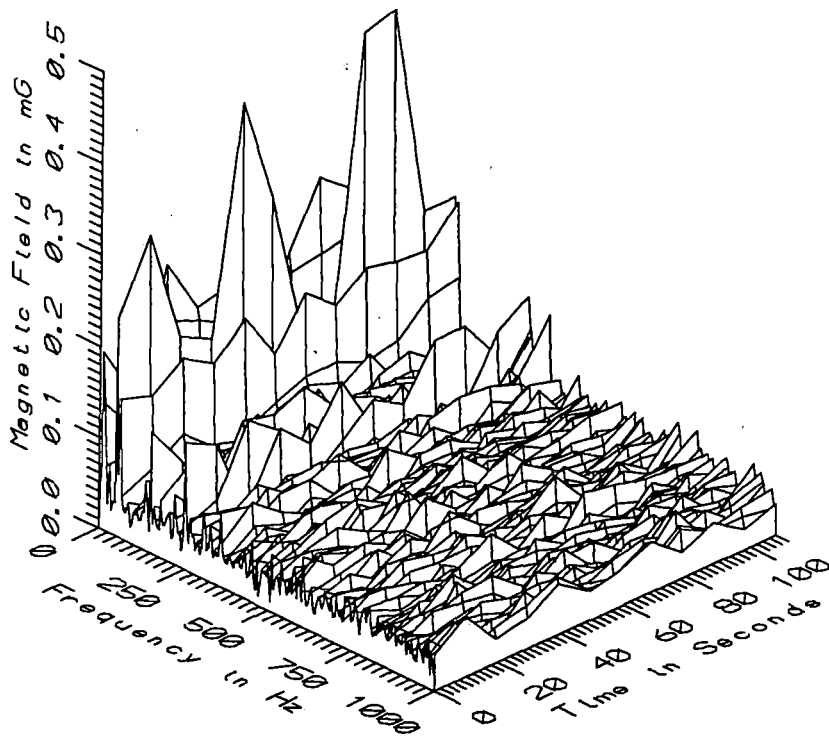

TGV016 - 60cm ABOVE FLOOR BETWEEN RELAY SHELVES, VENDOME RELAY ROOM

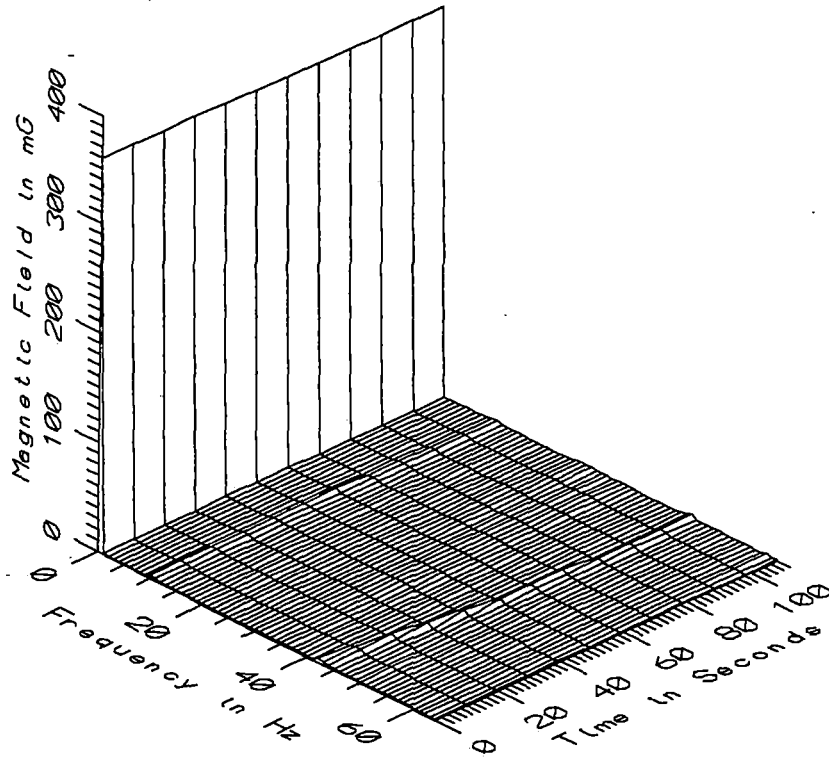

TGV016 - 110cm ABOVE FLOOR BETWEEN RELAY SHELVES, VENDOME RELAY ROOM

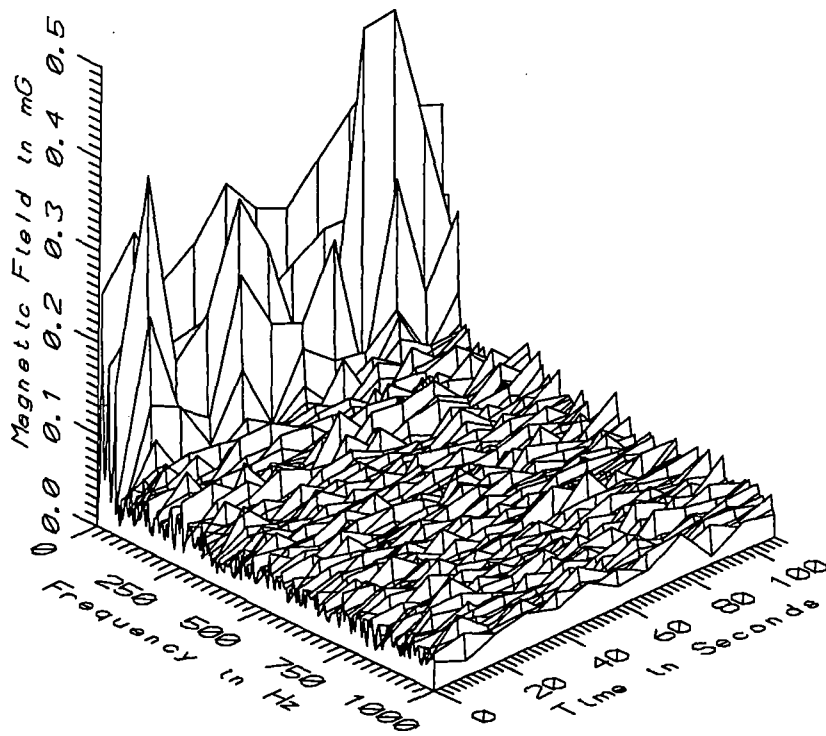

TGV016 - 110cm ABOVE FLOOR BETWEEN RELAY SHELVES, VENDOME RELAY ROOM

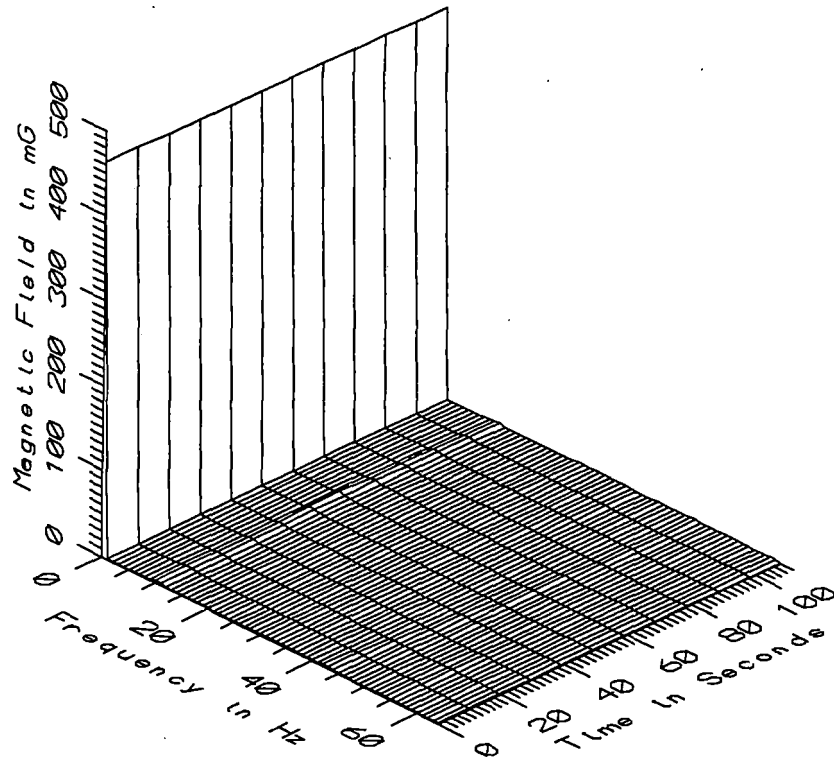

TGV016 - 160cm ABOVE FLOOR BETWEEN RELAY SHELVES, VENDOME RELAY ROOM

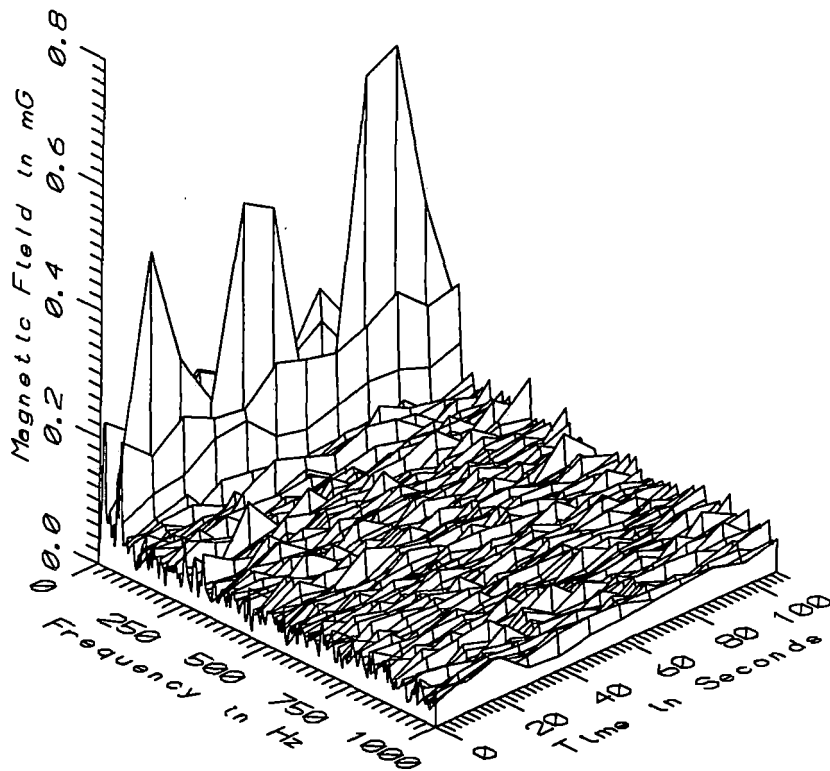

TGV016 - 160cm ABOVE FLOOR BETWEEN RELAY SHELVES, VENDOME RELAY ROOM

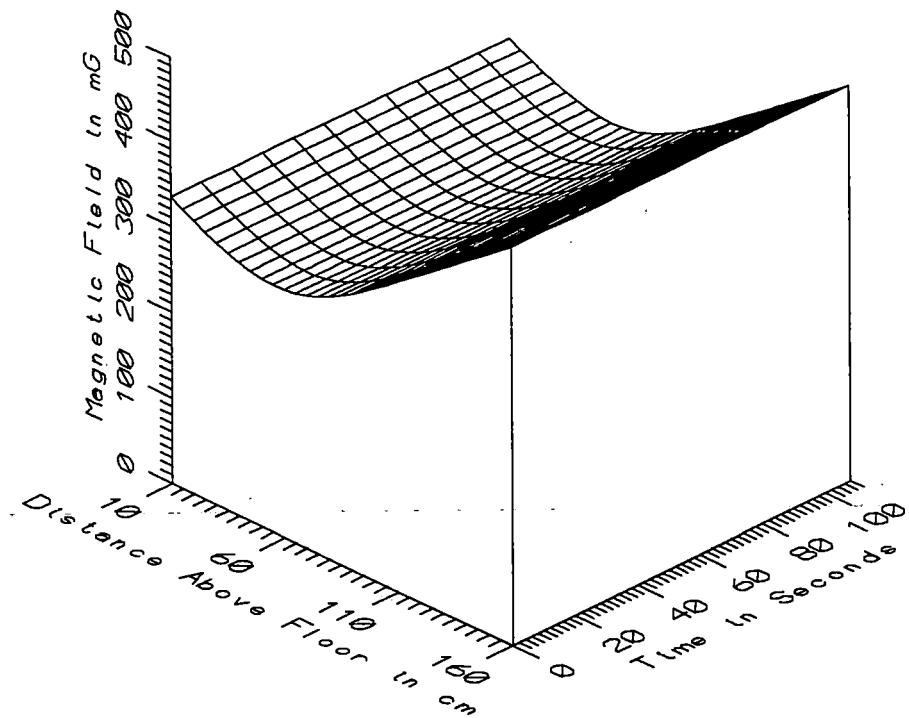

TGV016 - BETWEEN RELAY SHELVES, VENDOME RELAY ROOM - STATIC

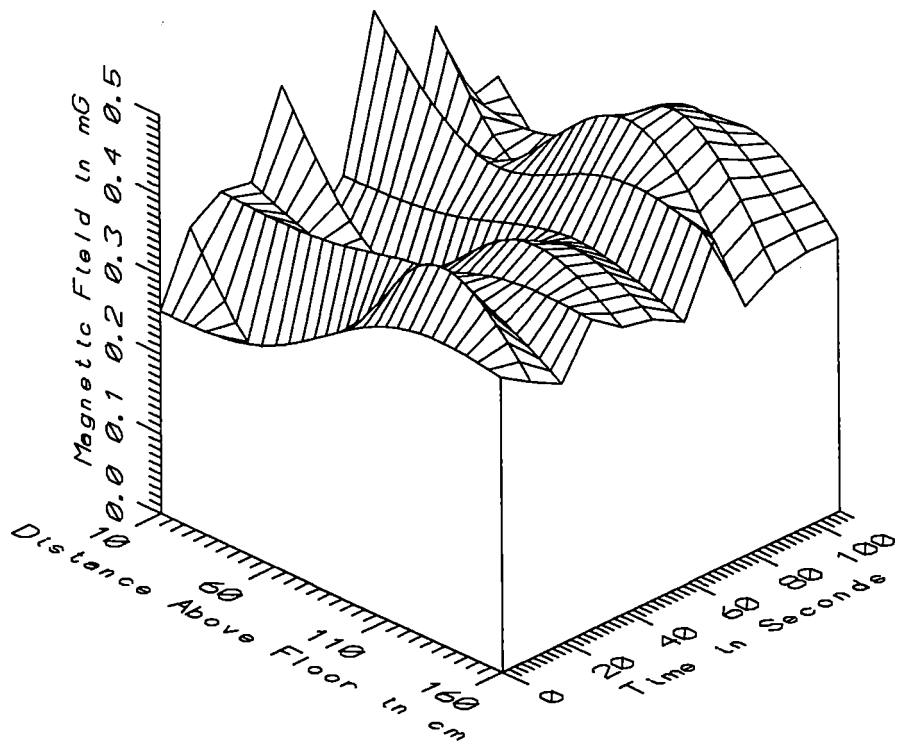

TGV016 - BETWEEN RELAY SHELVES, VENDOME RELAY ROOM - LOW FREQ, 5-45Hz

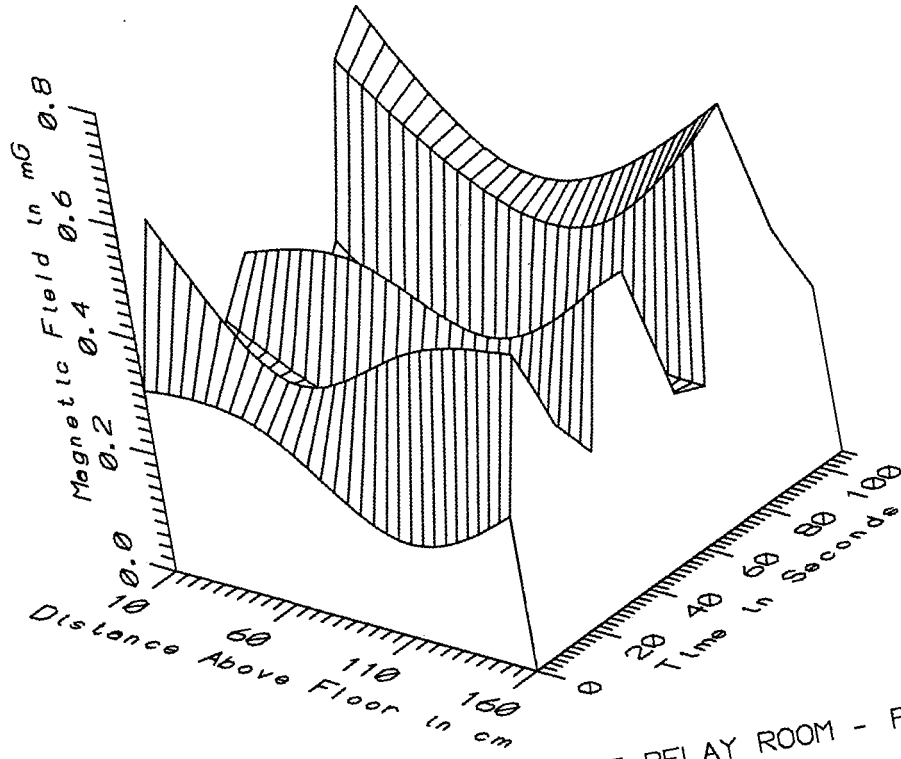

TGV016 - BETWEEN RELAY SHELVES, VENDOME RELAY ROOM - POWER FREQ, 50-60Hz

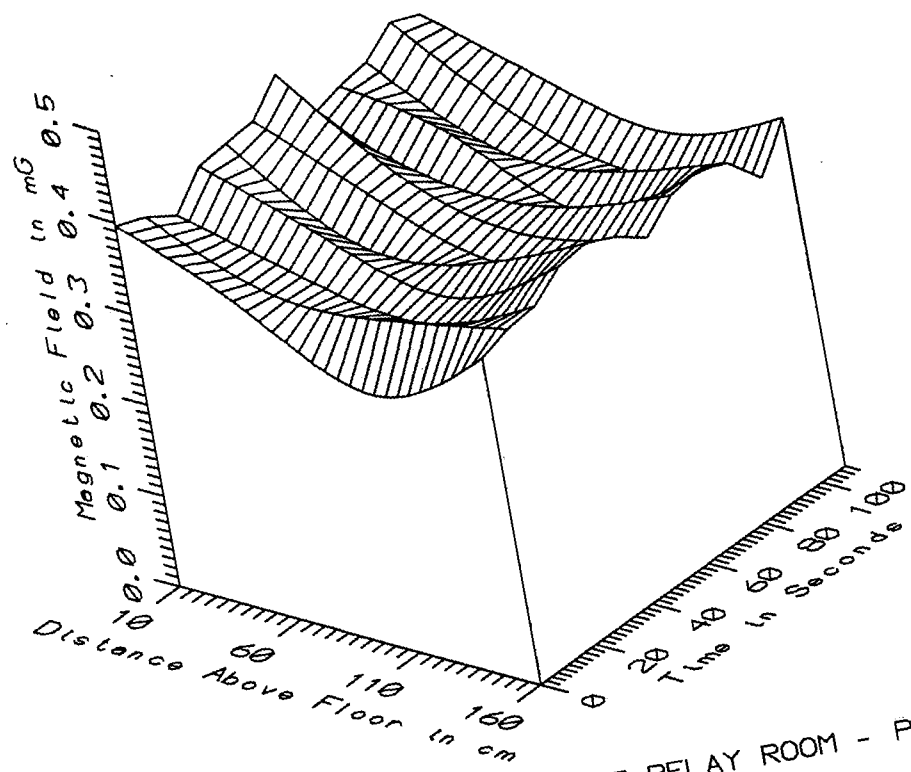

TGV016 - BETWEEN RELAY SHELVES, VENDOME RELAY ROOM - POWER HARM, 65-300Hz

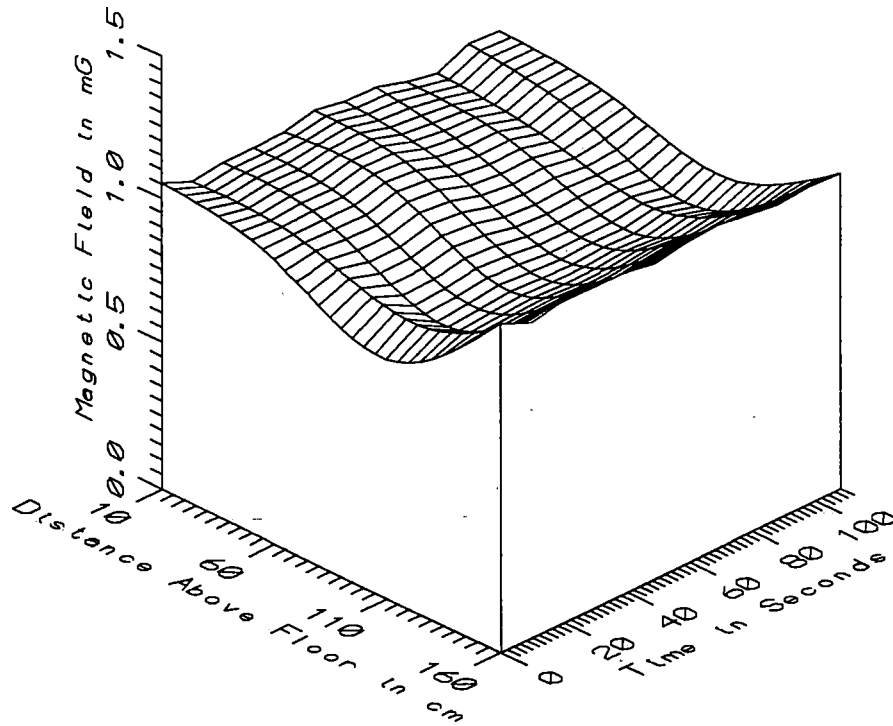

TGV016 - BETWEEN RELAY SHELVES, VENDOME RELAY ROOM - HIGH FREQ, 305-2560Hz

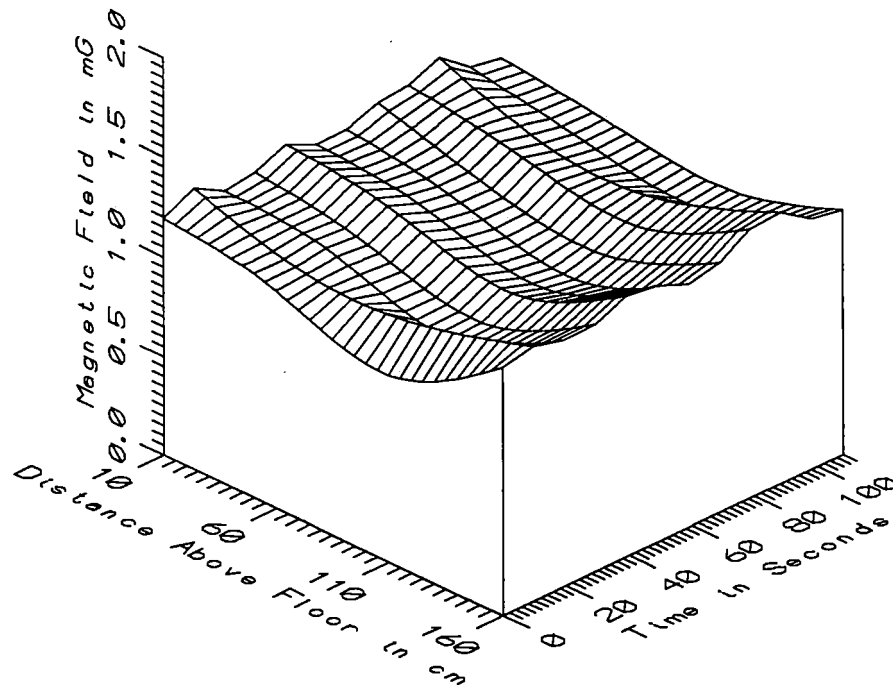

TGV016 - BETWEEN RELAY SHELVES, VENDOME RELAY ROOM - ALL FREQ, 5-2560Hz

TGV016 - VENDOME RELAY ROOM, BETWEEN RELAY SHELVES					TOTAL OF 12 SAMPLES	
FREQUENCY BAND	HEIGHT ABOVE FLOOR (cm)	MINIMUM MAGNETIC FIELD (mG)	MAXIMUM MAGNETIC FIELD (mG)	AVERAGE MAGNETIC FIELD (mG)	STANDARD DEVIATION (mG)	COEFFICIENT OF VARIATION (%)
STATIC	10	332.94	333.74	333.34	0.26	0.08
	60	286.72	287.80	287.14	0.32	0.11
	110	359.53	361.10	359.92	0.41	0.11
	160	462.42	464.14	463.31	0.53	0.11
5-45Hz LOW FREQ	10	0.25	0.50	0.35	0.08	22.19
	60	0.21	0.38	0.31	0.06	18.84
	110	0.37	0.48	0.42	0.04	9.52
	160	0.31	0.42	0.35	0.03	8.04
50-60Hz PWR FREQ	10	0.24	0.68	0.39	0.15	39.89
	60	0.19	0.47	0.32	0.10	30.48
	110	0.17	0.50	0.30	0.11	37.80
	160	0.25	0.68	0.42	0.15	36.98
65-300Hz PWR HARM	10	0.36	0.43	0.39	0.02	4.78
	60	0.32	0.35	0.34	0.01	3.40
	110	0.28	0.34	0.32	0.02	5.24
	160	0.34	0.40	0.38	0.02	4.49
305-2560Hz HIGH FREQ	10	0.99	1.05	1.03	0.02	1.90
	60	0.93	1.01	0.97	0.02	2.20
	110	0.81	0.89	0.85	0.02	2.61
	160	1.07	1.12	1.09	0.01	1.22
5-2560Hz ALL FREQ	10	1.18	1.33	1.23	0.05	3.95
	60	1.09	1.19	1.12	0.03	2.69
	110	0.95	1.16	1.05	0.06	6.05
	160	1.23	1.37	1.29	0.05	3.60

APPENDIX R

DATASET TGV017  
VENDOME STATION PLATFORM AS TRAIN FROM PARIS PASSED

Measurement Setup Code:           Staff: 19       Reference: 20  
  Drawing: A-5

Vehicle Status:                    Single train set from Paris passed  
  60 seconds into the record

Measurement Date:                 September 8, 1992

Measurement Time:                 Start:     16:03:27  
  End:       16:05:05

Number of Samples:                13

Programmed Sample Interval:      5 sec

Actual Sample Interval:           8.2 sec

Frequency Spectrum Parameters

<u>Probe Type:</u>	<u>Wideband</u>	<u>Static</u>
Maximum Frequency (Hz)	2560	64
Minimum Frequency (Hz)	5	0
Spectral Bandwidth (Hz)	5	1

Missing or Suspect Data:         None



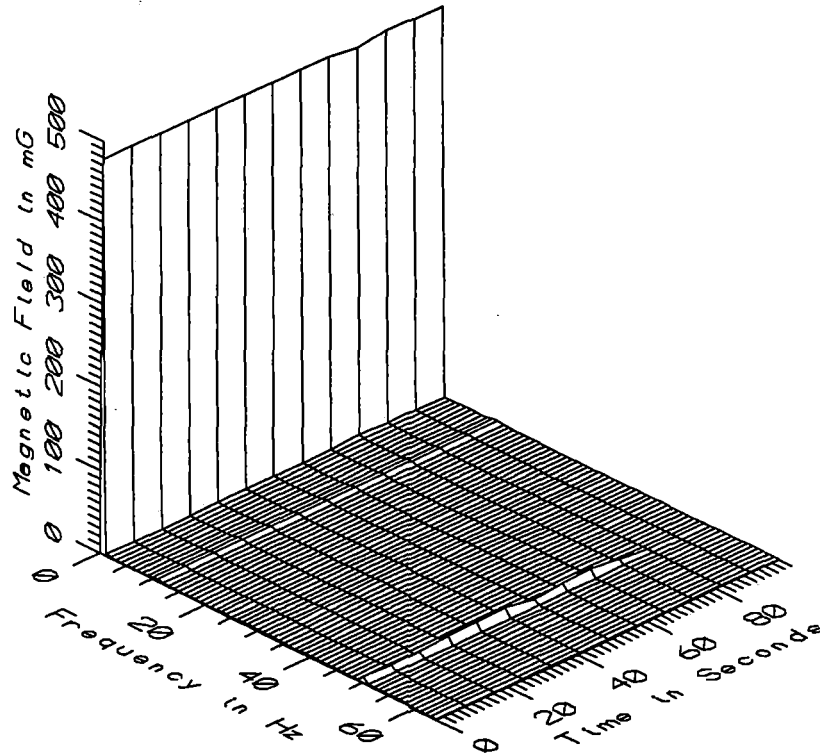

TGV017 - 10cm ABOVE FLOOR AT EDGE OF PLATFORM, VENDOME STATION

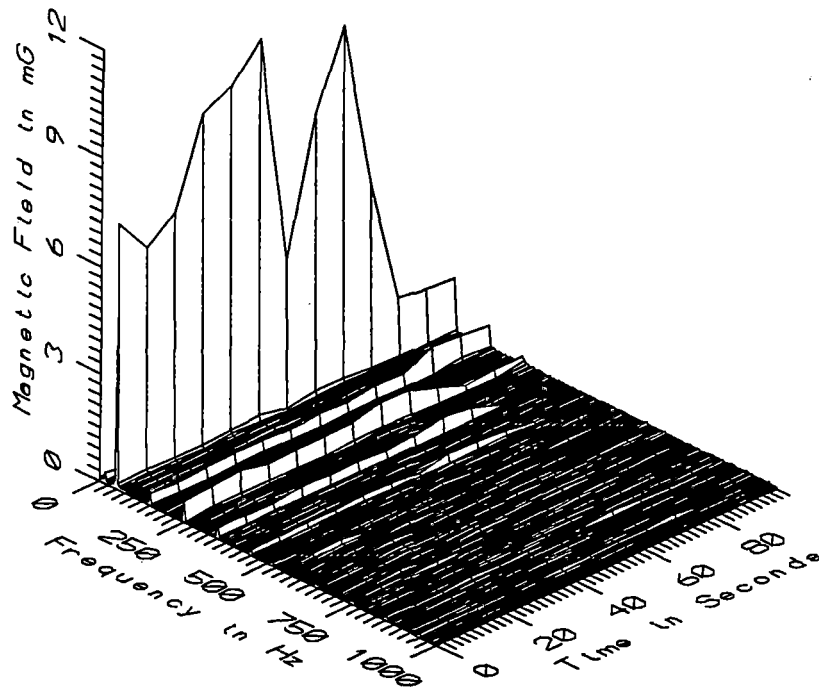

TGV017 - 10cm ABOVE FLOOR AT EDGE OF PLATFORM, VENDOME STATION

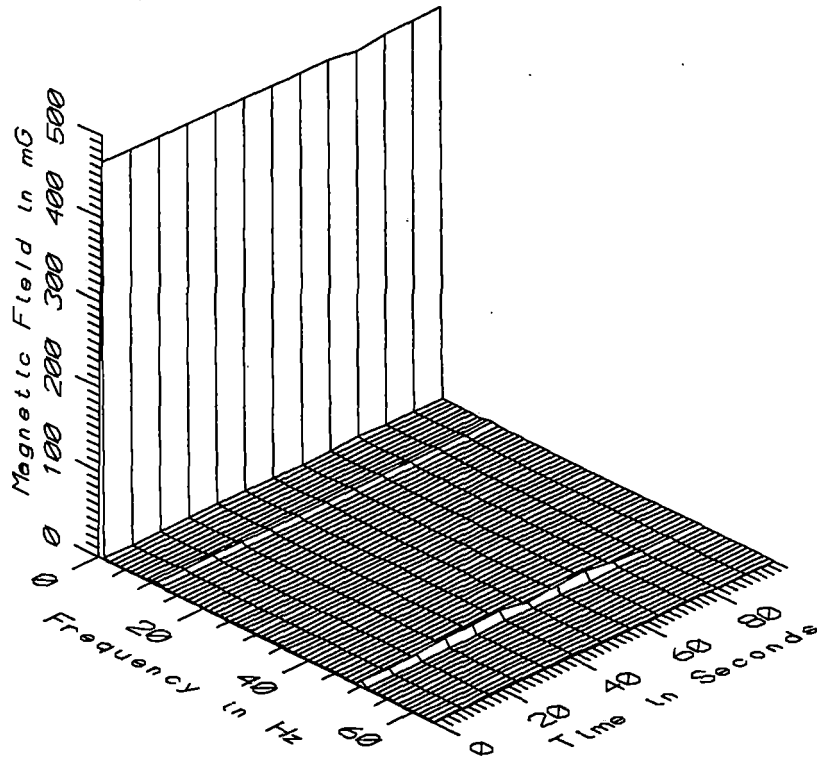

TGV017 - 60cm ABOVE FLOOR AT EDGE OF PLATFORM, VENDOME STATION

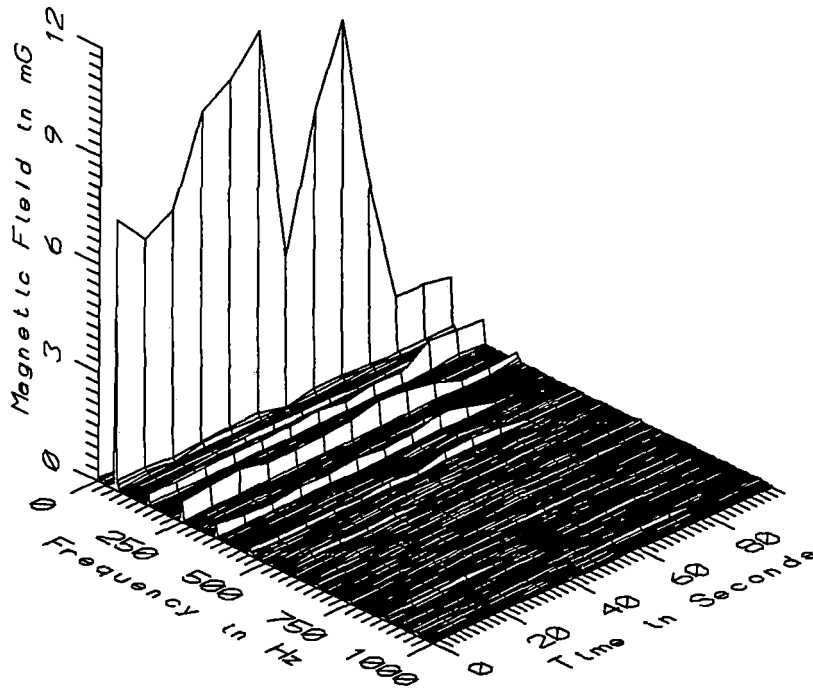

TGV017 - 60cm ABOVE FLOOR AT EDGE OF PLATFORM, VENDOME STATION

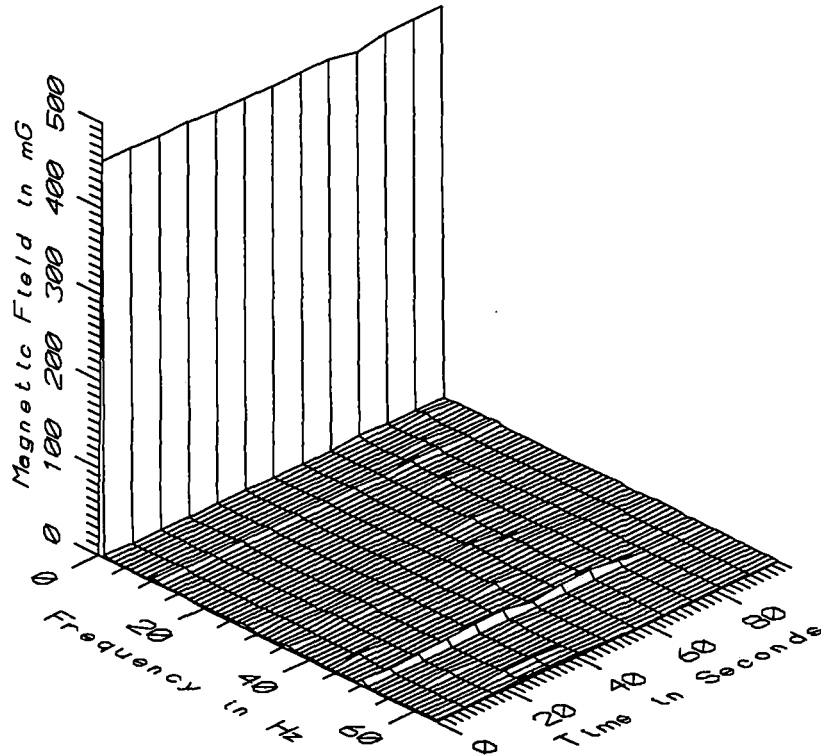

TGV017 - 110cm ABOVE FLOOR AT EDGE OF PLATFORM, VENDOME STATION

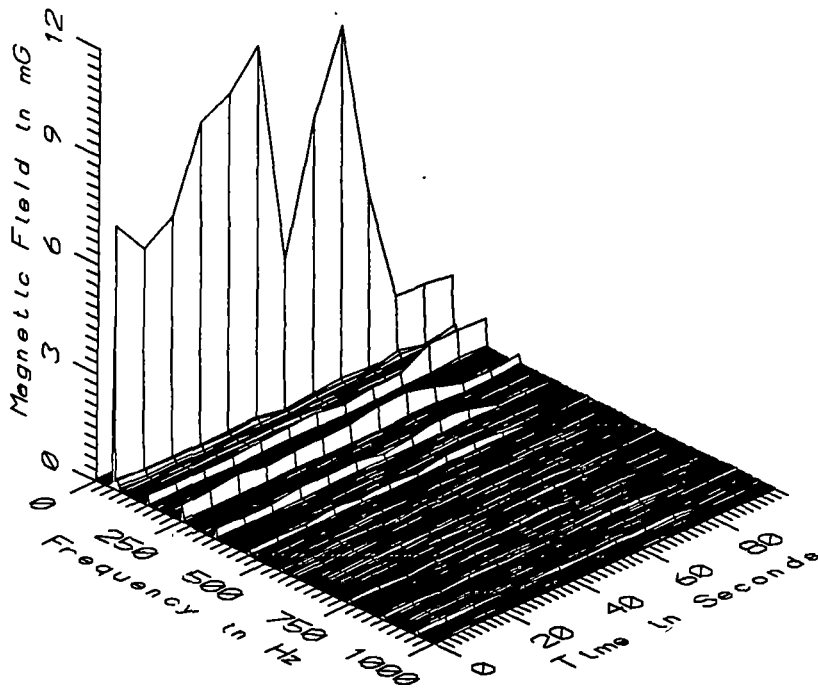

TGV017 - 110cm ABOVE FLOOR AT EDGE OF PLATFORM, VENDOME STATION

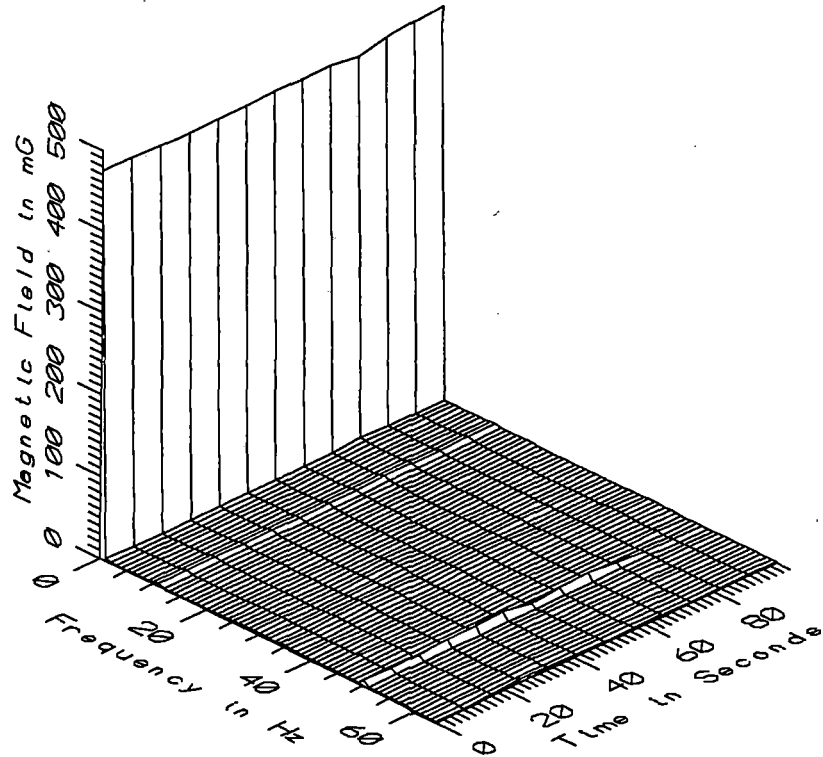

TGV017 - 160cm ABOVE FLOOR AT EDGE OF PLATFORM, VENDOME STATION

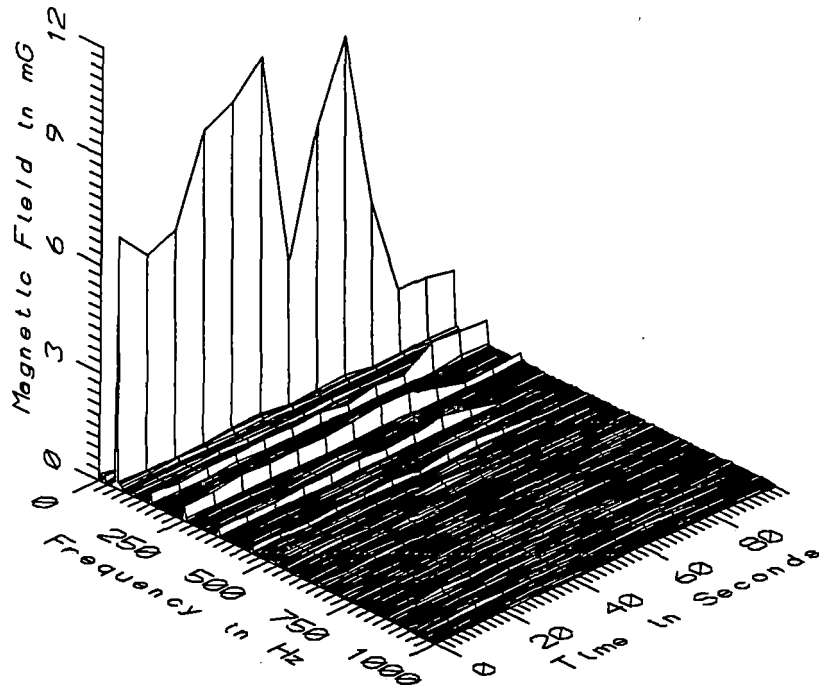

TGV017 - 160cm ABOVE FLOOR AT EDGE OF PLATFORM, VENDOME STATION

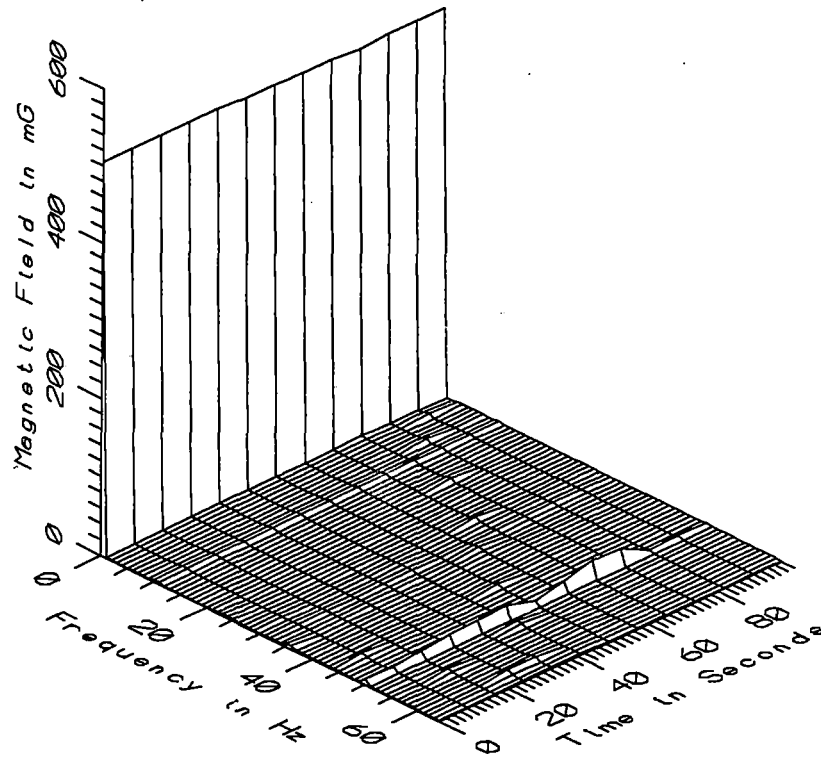

TGV017 - REFERENCE PROBE - 5m FROM EDGE OF PLATFORM, VENDOME STATION

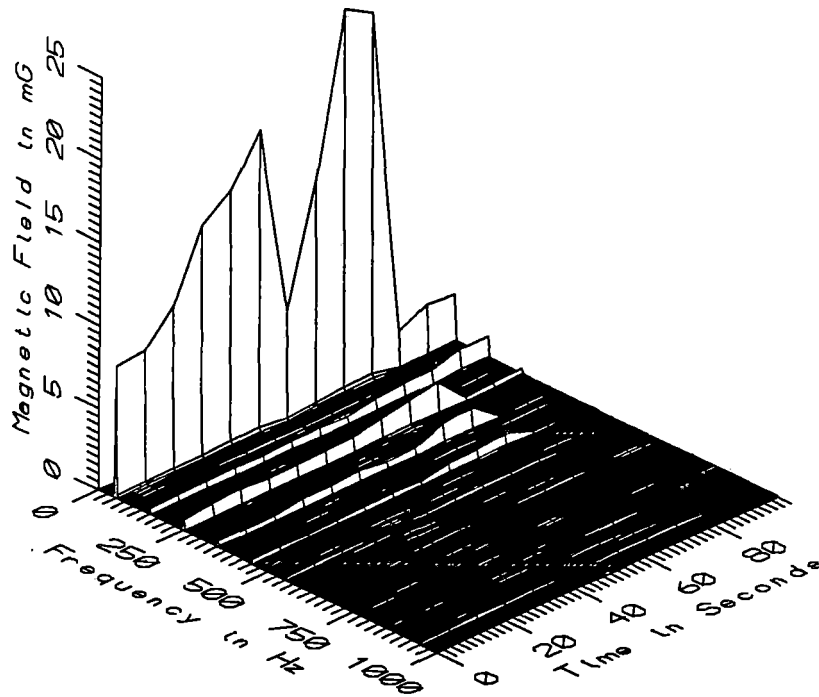

TGV017 - REFERENCE PROBE - 5m FROM EDGE OF PLATFORM, VENDOME STATION

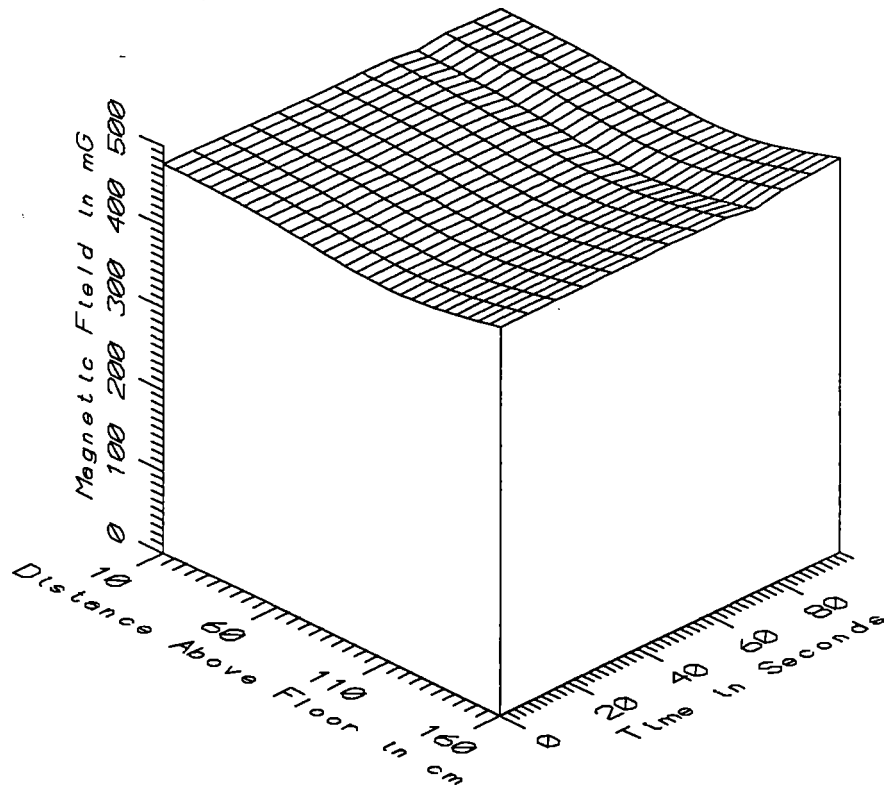

TGV017 - EDGE OF PLATFORM, VENDOME STATION - STATIC

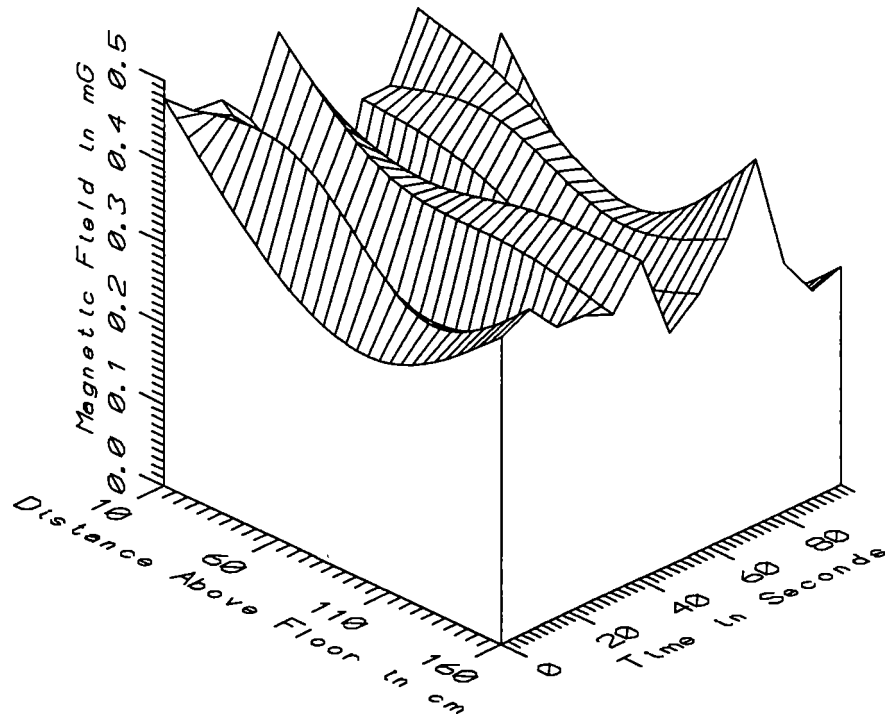

TGV017 - EDGE OF PLATFORM, VENDOME STATION - LOW FREQ, 5-45Hz

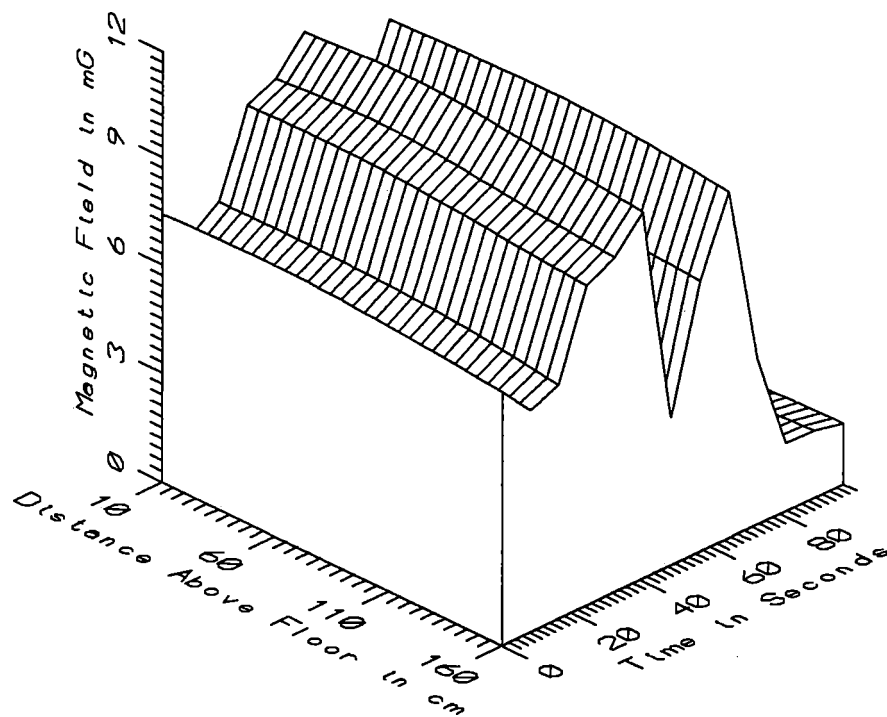

TGV017 - EDGE OF PLATFORM, VENDOME STATION - POWER FREQ, 50-60Hz

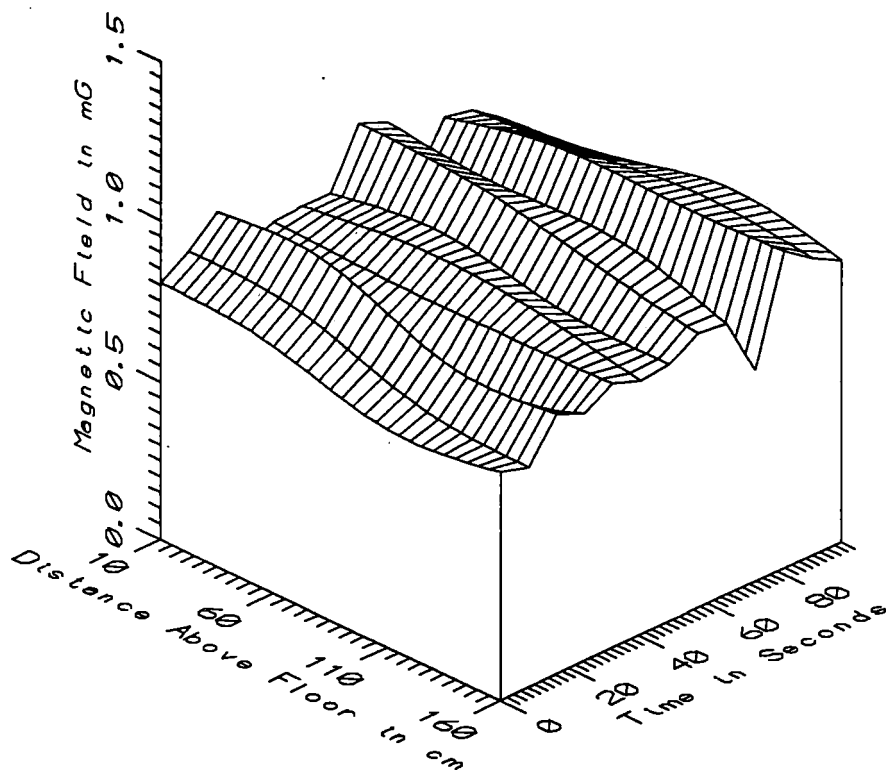

TGV017 - EDGE OF PLATFORM, VENDOME STATION - POWER HARM, 65-300Hz

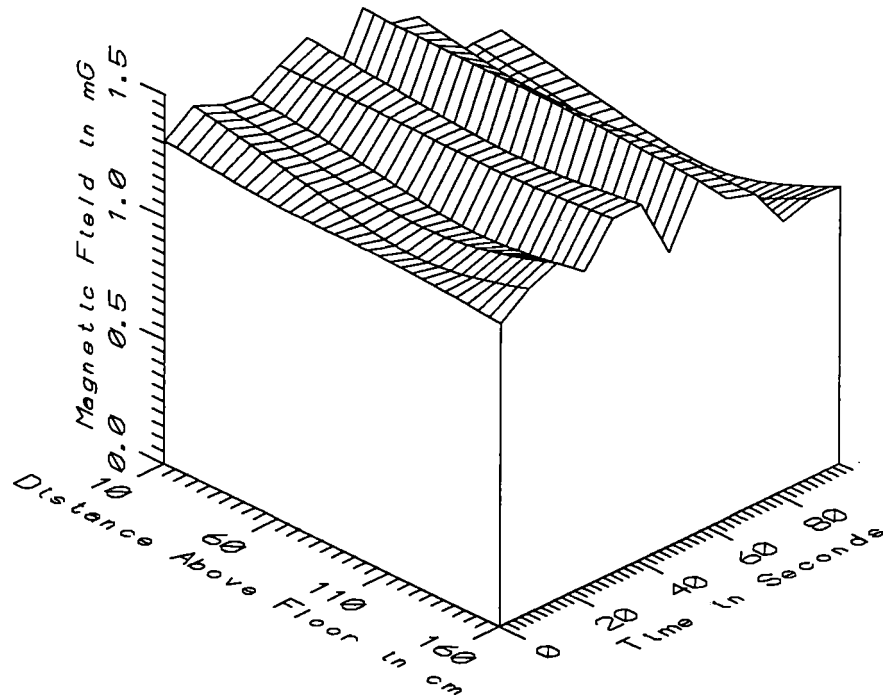

TGV017 - EDGE OF PLATFORM, VENDOME STATION - HIGH FREQ, 305-2560Hz

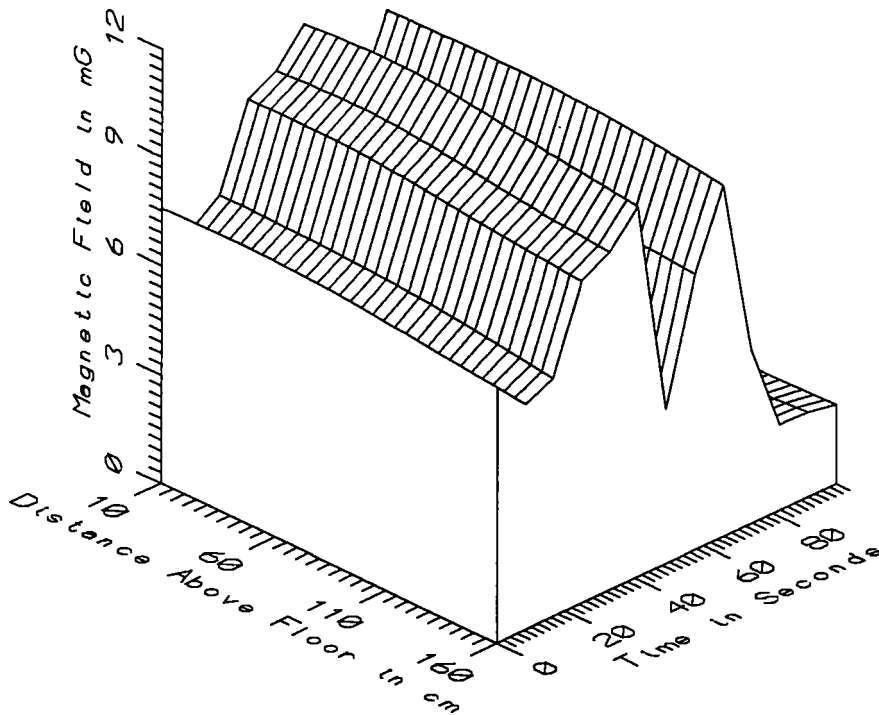

TGV017 - EDGE OF PLATFORM, VENDOME STATION - ALL FREQ, 5-2560Hz



TGV017 - ON VENDOME PLATFORM - TRAIN FROM PARIS					TOTAL OF 13 SAMPLES	
FREQUENCY BAND	HEIGHT ABOVE FLOOR (cm)	MINIMUM MAGNETIC FIELD (mG)	MAXIMUM MAGNETIC FIELD (mG)	AVERAGE MAGNETIC FIELD (mG)	STANDARD DEVIATION (mG)	COEFFICIENT OF VARIATION (%)
STATIC	10	473.34	478.86	477.55	1.50	0.31
	60	463.31	469.49	467.81	1.46	0.31
	110	449.21	455.78	454.40	1.65	0.36
	160	470.84	485.77	476.59	3.84	0.81
5-45Hz LOW FREQ	10	0.22	0.49	0.39	0.08	21.54
	60	0.19	0.44	0.32	0.07	23.21
	110	0.16	0.39	0.28	0.07	27.14
	160	0.26	0.45	0.35	0.06	16.31
50-60Hz PWR FREQ	10	1.53	10.70	6.36	3.29	51.71
	60	1.45	10.85	6.41	3.34	52.09
	110	1.58	10.51	6.26	3.21	51.25
	160	1.66	10.13	6.07	3.03	49.99
65-300Hz PWR HARM	10	0.76	1.01	0.86	0.07	8.57
	60	0.78	0.99	0.88	0.07	8.14
	110	0.69	0.99	0.85	0.10	12.06
	160	0.67	1.00	0.83	0.09	10.91
305-2560Hz HIGH FREQ	10	1.09	1.48	1.31	0.13	9.98
	60	1.01	1.47	1.25	0.15	12.10
	110	0.96	1.46	1.22	0.17	13.62
	160	1.09	1.44	1.27	0.12	9.37
5-2560Hz ALL FREQ	10	2.09	10.84	6.63	3.14	47.28
	60	1.98	10.98	6.66	3.19	47.88
	110	2.08	10.65	6.51	3.07	47.26
	160	2.21	10.27	6.33	2.89	45.62

APPENDIX S

DATASET TGV018  
VENDOME STATION PLATFORM AS TRAIN FROM PARIS PASSED

Measurement Setup Code:        Staff: 19        Reference: 20  
   Drawing: A-5

Vehicle Status:                Single train set from Paris passed  
   38 seconds into the record

Measurement Date:              September 8, 1992

Measurement Time:              Start:        16:34:02  
   End:         16:44:35

Number of Samples:             73

Programmed Sample Interval:   5 sec

Actual Sample Interval:        8.8 sec

Frequency Spectrum Parameters

<u>Probe Type:</u>	<u>Wideband</u>	<u>Static</u>
Maximum Frequency (Hz)	2560	64
Minimum Frequency (Hz)	5	0
Spectral Bandwidth (Hz)	5	1

Missing or Suspect Data:        None

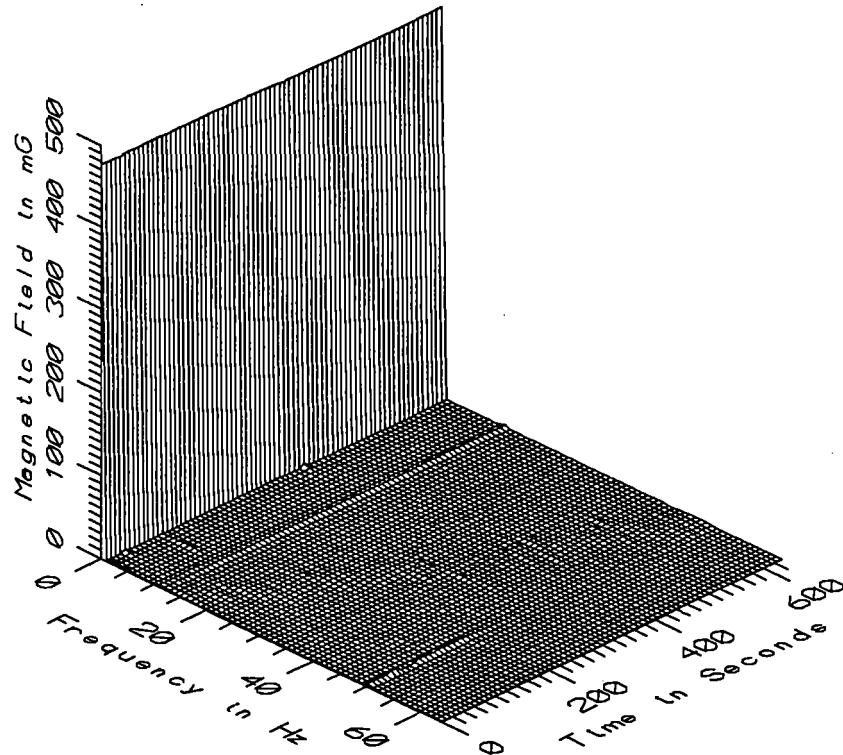

TGV018 - 10cm ABOVE FLOOR AT EDGE OF PLATFORM, VENDOME STATION

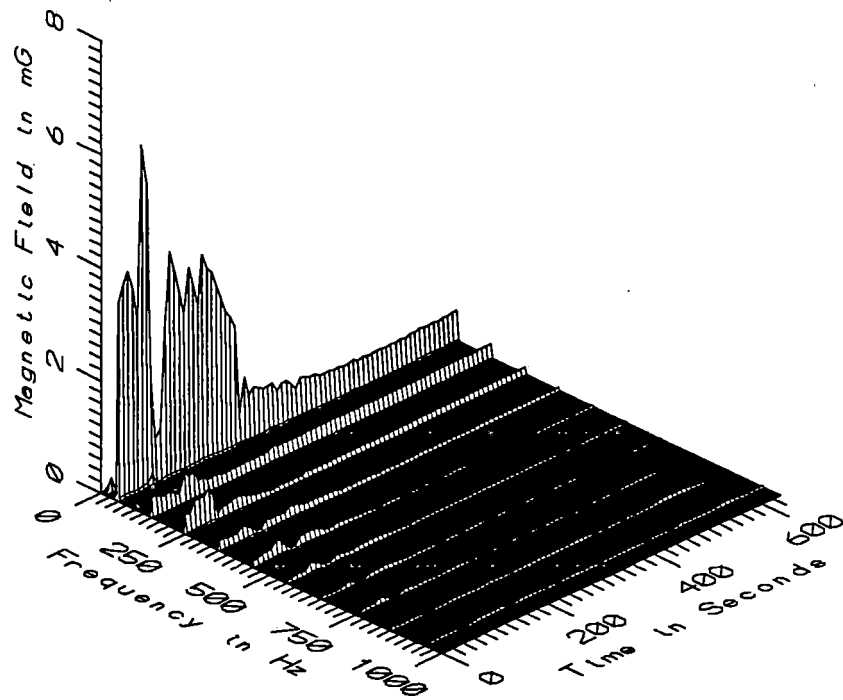

TGV018 - 10cm ABOVE FLOOR AT EDGE OF PLATFORM, VENDOME STATION

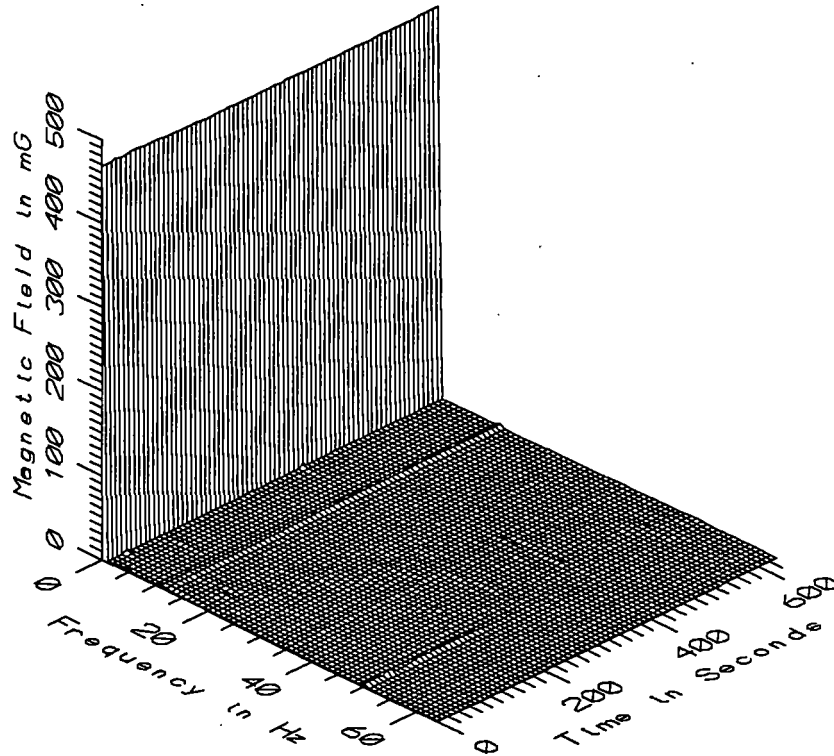

TGV018 - 60cm ABOVE FLOOR AT EDGE OF PLATFORM, VENDOME STATION

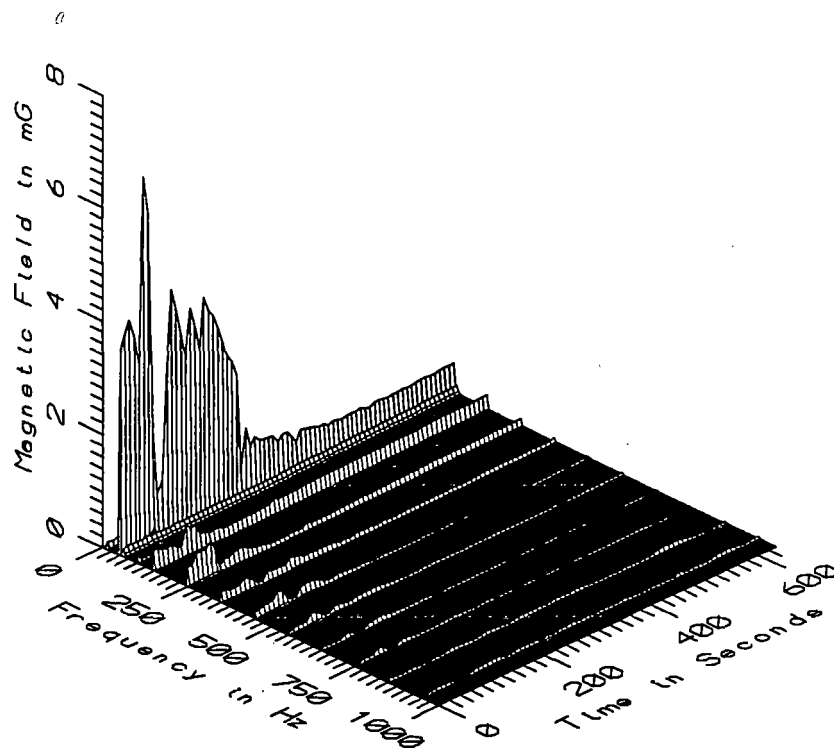

TGV018 - 60cm ABOVE FLOOR AT EDGE OF PLATFORM, VENDOME STATION

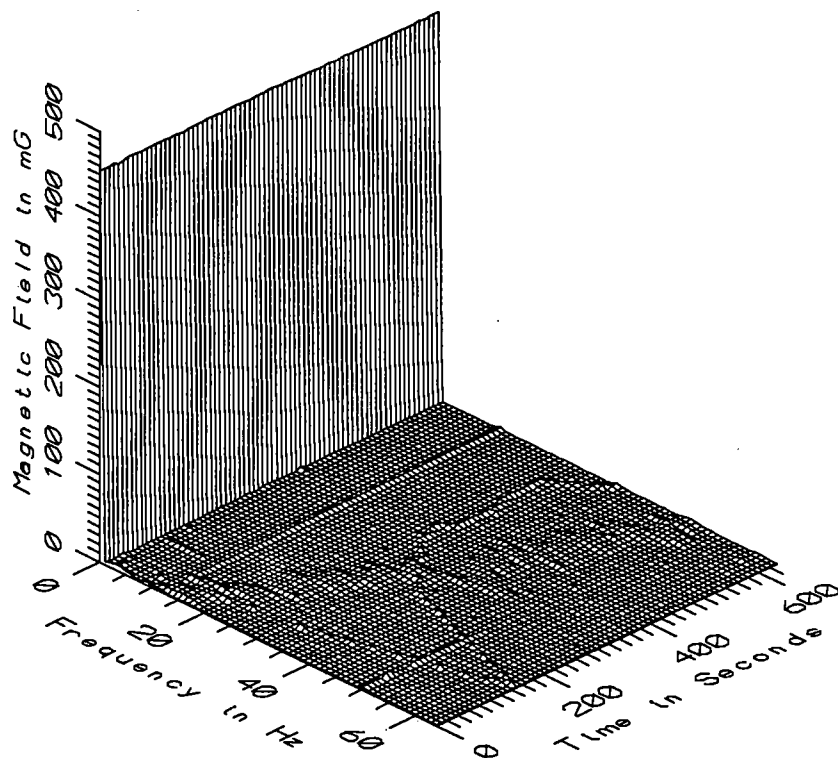

TGV018 - 110cm ABOVE FLOOR AT EDGE OF PLATFORM, VENDOME STATION

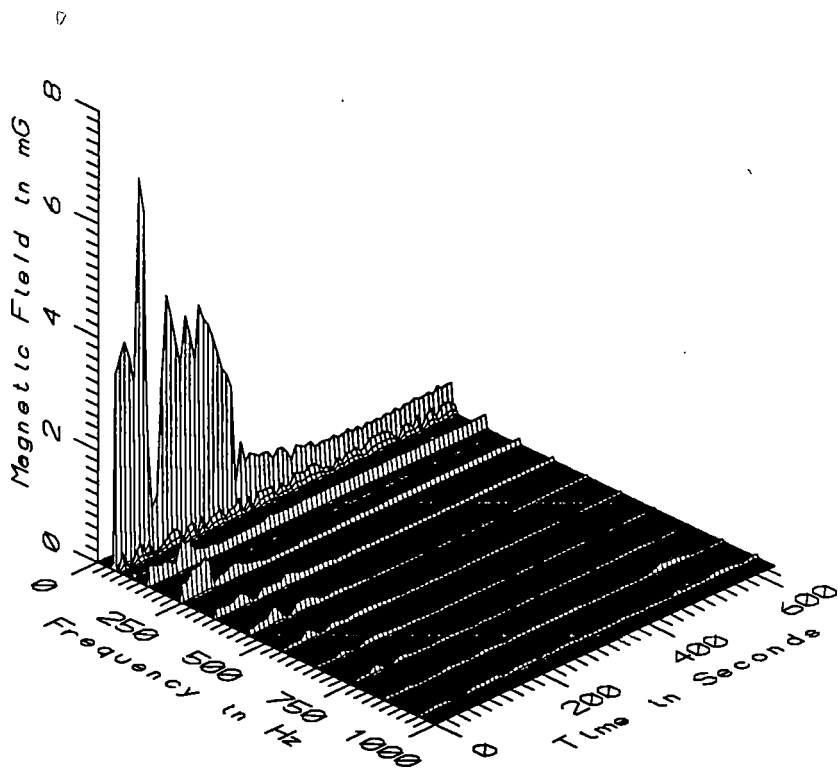

TGV018 - 110cm ABOVE FLOOR AT EDGE OF PLATFORM, VENDOME STATION

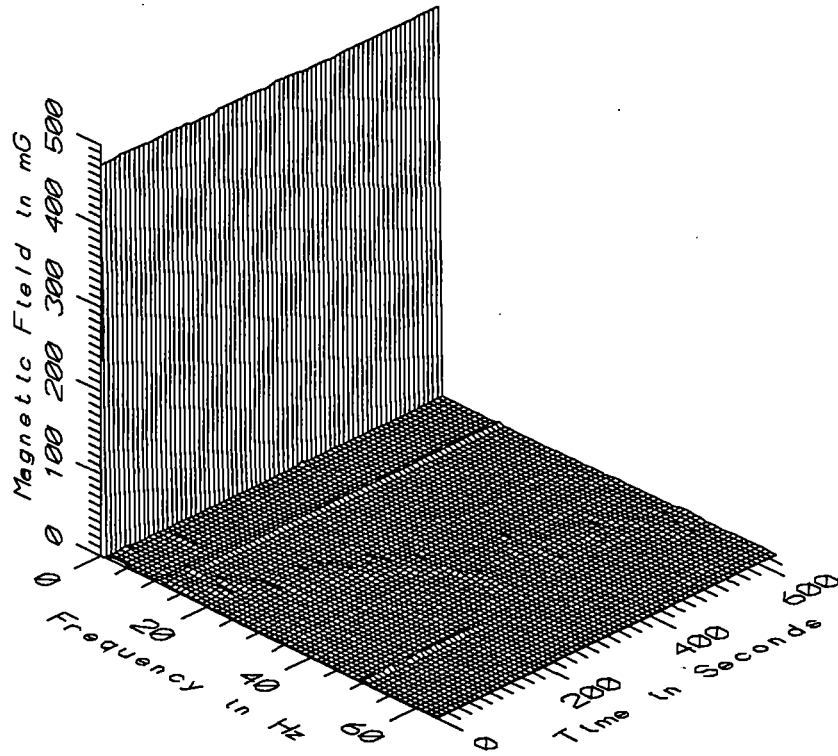

TGV018 - 160cm ABOVE FLOOR AT EDGE OF PLATFORM, VENDOME STATION

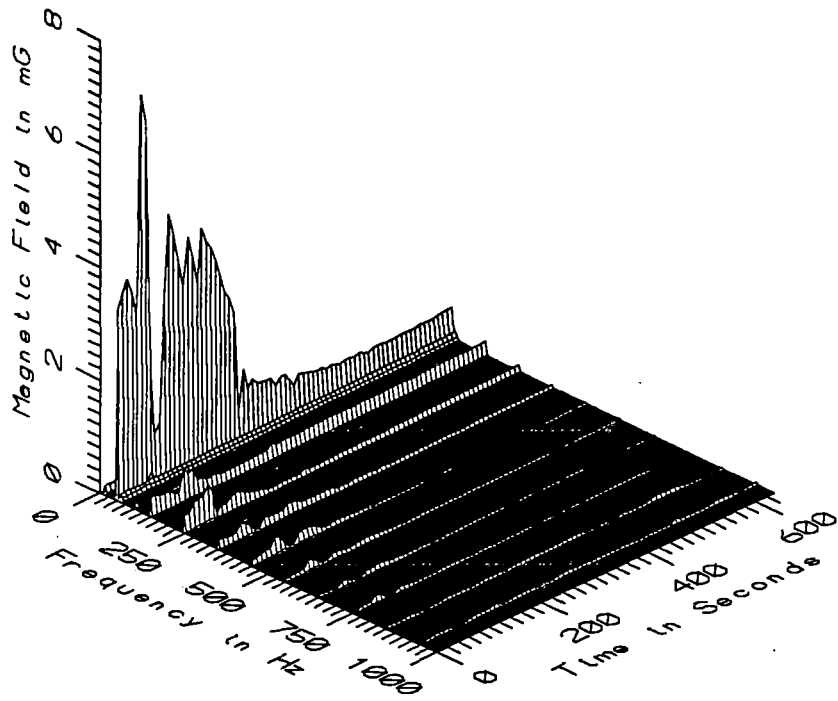

TGV018 - 160cm ABOVE FLOOR AT EDGE OF PLATFORM, VENDOME STATION

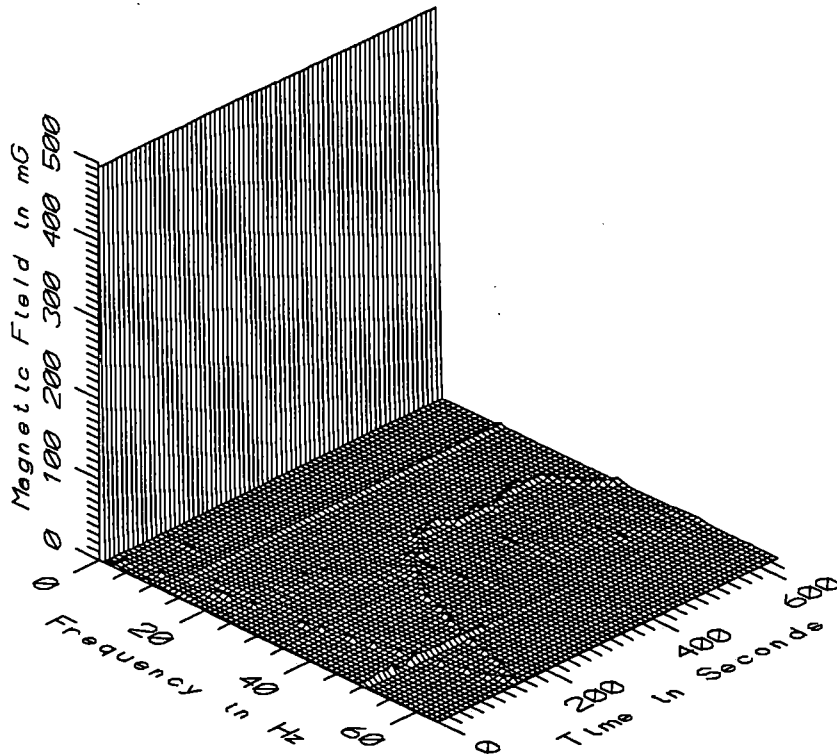

TGV018 - REFERENCE PROBE - 5m FROM EDGE OF PLATFORM, VENDOME STATION

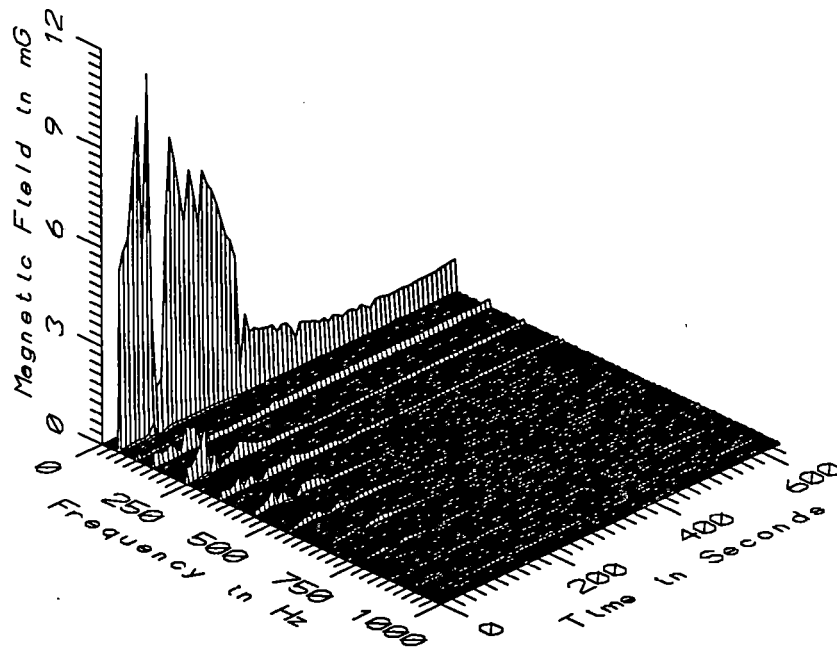

TGV018 - REFERENCE PROBE - 5m FROM EDGE OF PLATFORM, VENDOME STATION

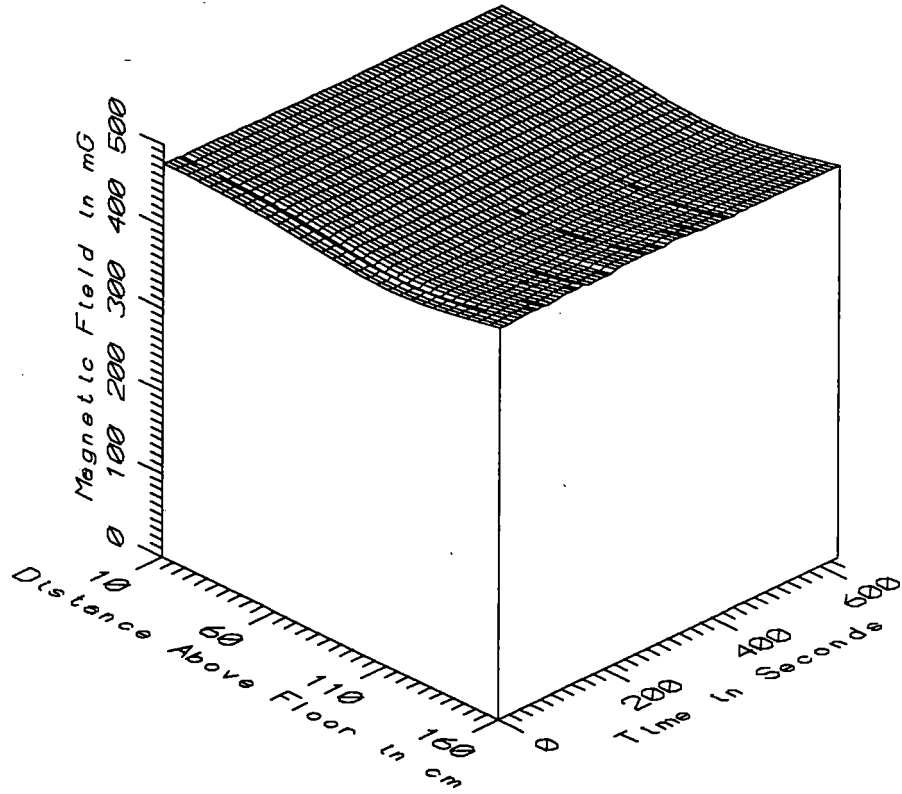

TGV018 - EDGE OF PLATFORM, VENDOME STATION - STATIC

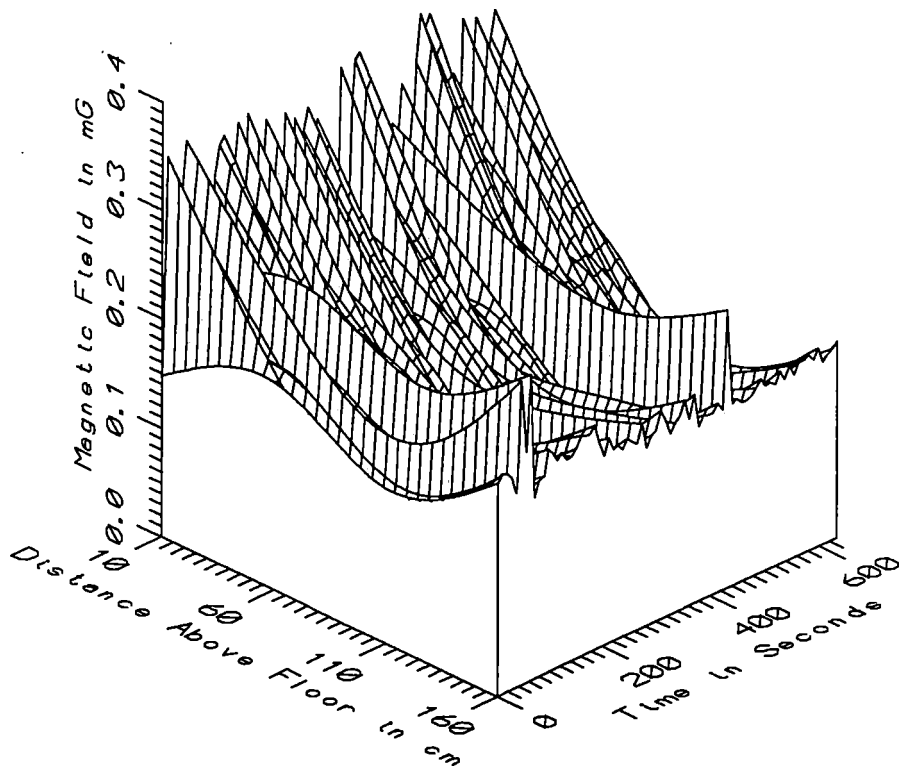

TGV018 - EDGE OF PLATFORM, VENDOME STATION - LOW FREQ, 5-45Hz



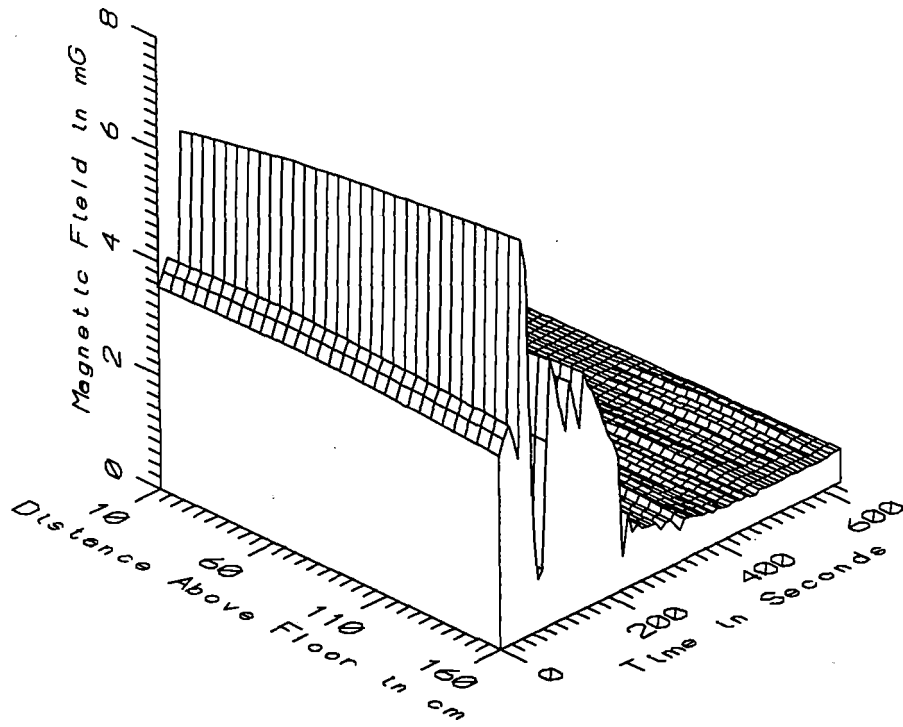

TGV018 - EDGE OF PLATFORM, VENDOME STATION - POWER FREQ, 50-60Hz

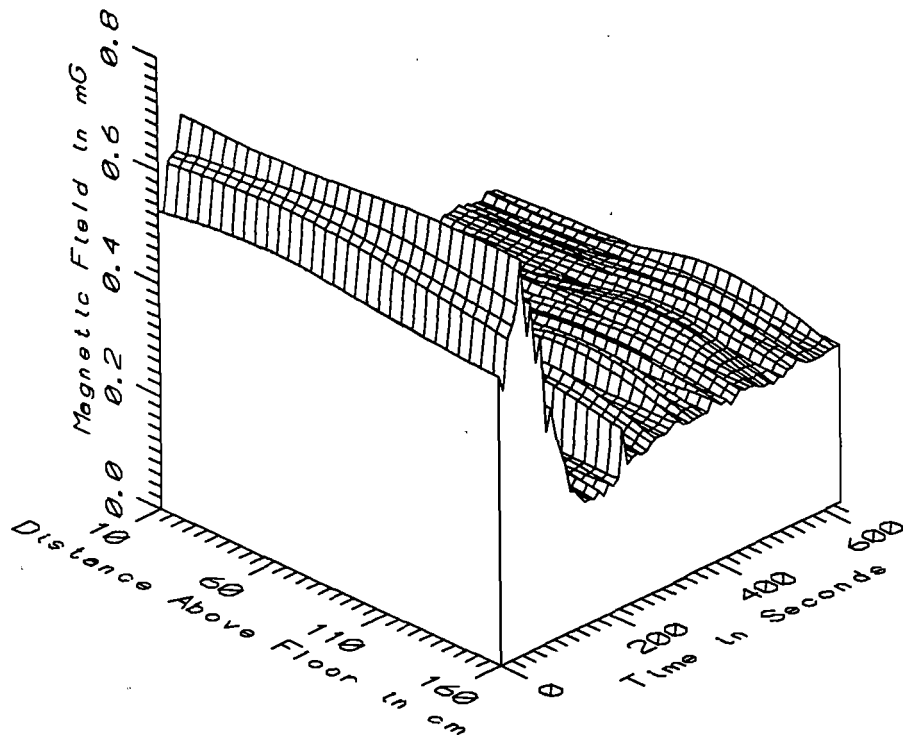

TGV018 - EDGE OF PLATFORM, VENDOME STATION - POWER HARM, 65-300Hz

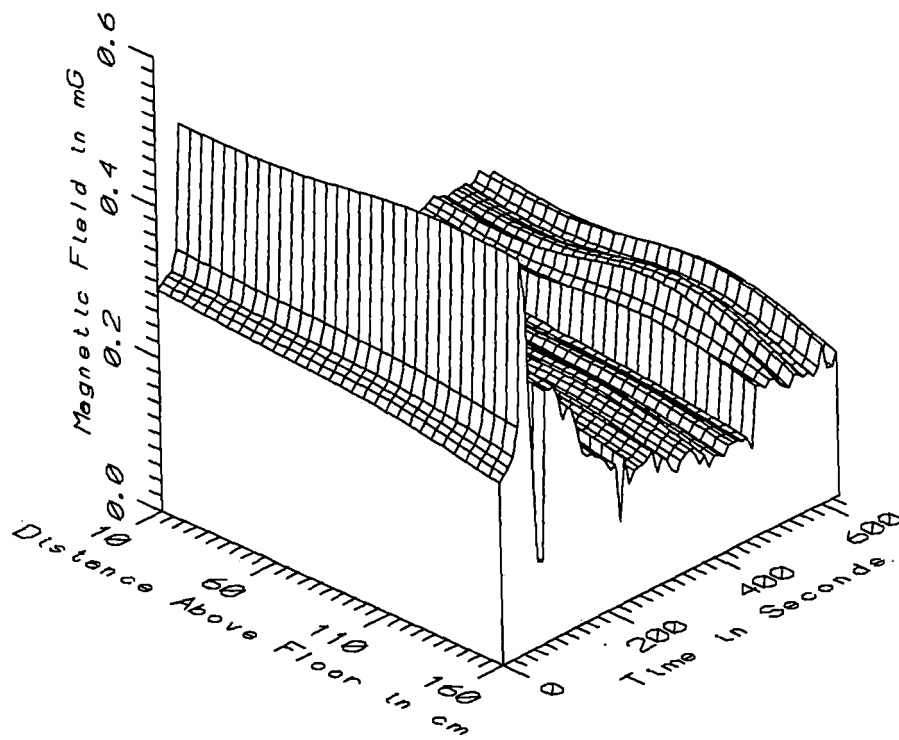

TGV018 - EDGE OF PLATFORM, VENDOME STATION - HIGH FREQ, 305-2560Hz

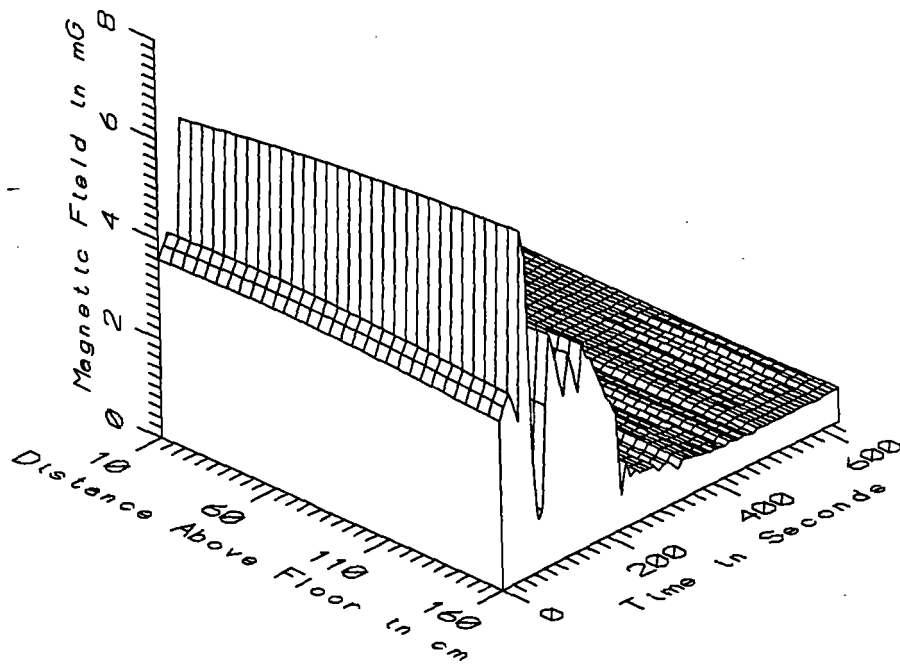

TGV018 - EDGE OF PLATFORM, VENDOME STATION - ALL FREQ, 5-2560Hz

TGV018 - ON VENDOME PLATFORM - TRAIN FROM PARIS				TOTAL OF 73 SAMPLES		
FREQUENCY BAND	HEIGHT ABOVE FLOOR (cm)	MINIMUM MAGNETIC FIELD (mG)	MAXIMUM MAGNETIC FIELD (mG)	AVERAGE MAGNETIC FIELD (mG)	STANDARD DEVIATION (mG)	COEFFICIENT OF VARIATION (%)
STATIC	10	474.72	477.05	476.41	0.35	0.07
	60	466.49	469.38	468.26	0.50	0.11
	110	451.61	456.11	454.62	0.61	0.13
	160	473.88	480.00	476.75	1.30	0.27
5-45Hz LOW FREQ	10	0.10	0.37	0.25	0.08	33.89
	60	0.16	0.26	0.18	0.02	9.85
	110	0.06	0.23	0.12	0.03	26.93
	160	0.16	0.29	0.19	0.02	12.18
50-60Hz PWR FREQ	10	0.48	6.11	1.52	1.41	92.81
	60	0.49	6.49	1.58	1.49	94.32
	110	0.49	6.76	1.64	1.53	93.52
	160	0.51	6.98	1.66	1.58	95.06
65-300Hz PWR HARM	10	0.20	0.68	0.30	0.11	36.39
	60	0.22	0.68	0.31	0.11	35.52
	110	0.21	0.70	0.33	0.11	33.07
	160	0.22	0.71	0.32	0.11	35.15
305-2560Hz HIGH FREQ	10	0.18	0.50	0.24	0.05	22.56
	60	0.15	0.50	0.22	0.06	28.89
	110	0.12	0.52	0.22	0.07	32.04
	160	0.11	0.52	0.20	0.07	37.82
5-2560Hz ALL FREQ	10	0.63	6.18	1.63	1.36	83.79
	60	0.62	6.55	1.67	1.46	87.38
	110	0.59	6.82	1.72	1.50	87.41
	160	0.61	7.04	1.74	1.55	88.95

APPENDIX T

DATASET TGV019  
VENDOME STATION PLATFORM AS TRAIN TO PARIS PASSED

Measurement Setup Code: Staff: 19 Reference: 20  
Drawing: A-5

Vehicle Status: Single train set to Paris passed  
200 seconds into the record

Measurement Date: September 8, 1992

Measurement Time: Start: 16:50:37  
End: 16:54:10

Number of Samples: 25

Programmed Sample Interval: 5 sec

Actual Sample Interval: 8.9 sec

Frequency Spectrum Parameters

<u>Probe Type:</u>	<u>Wideband</u>	<u>Static</u>
Maximum Frequency (Hz)	2560	64
Minimum Frequency (Hz)	5	0
Spectral Bandwidth (Hz)	5	1

Missing or Suspect Data: None

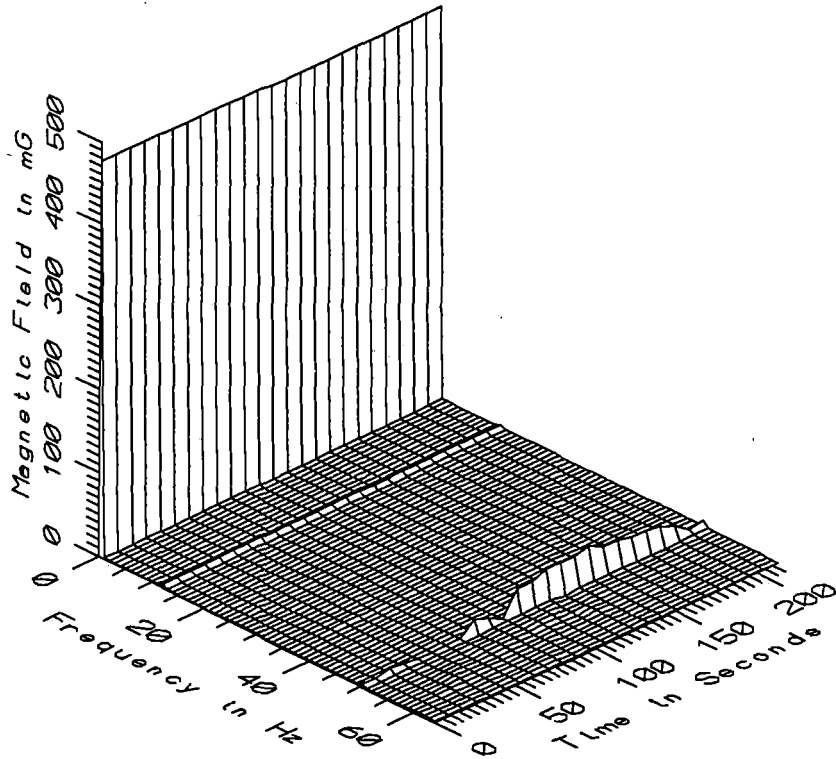

TGV019 - 10cm ABOVE FLOOR AT EDGE OF PLATFORM, VENDOME STATION

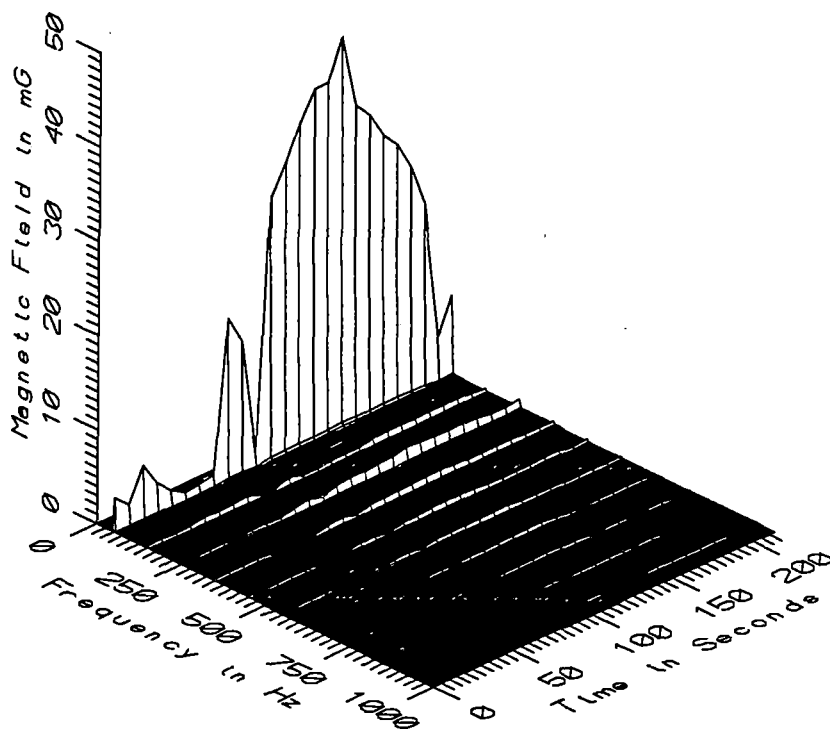

TGV019 - 10cm ABOVE FLOOR AT EDGE OF PLATFORM, VENDOME STATION

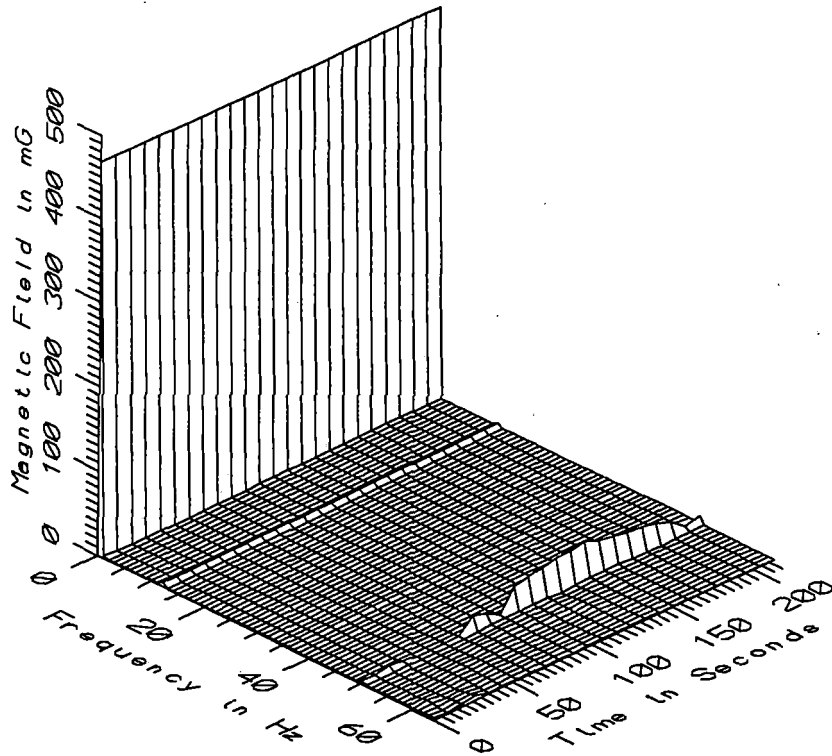

TGV019 - 60cm ABOVE FLOOR AT EDGE OF PLATFORM, VENDOME STATION

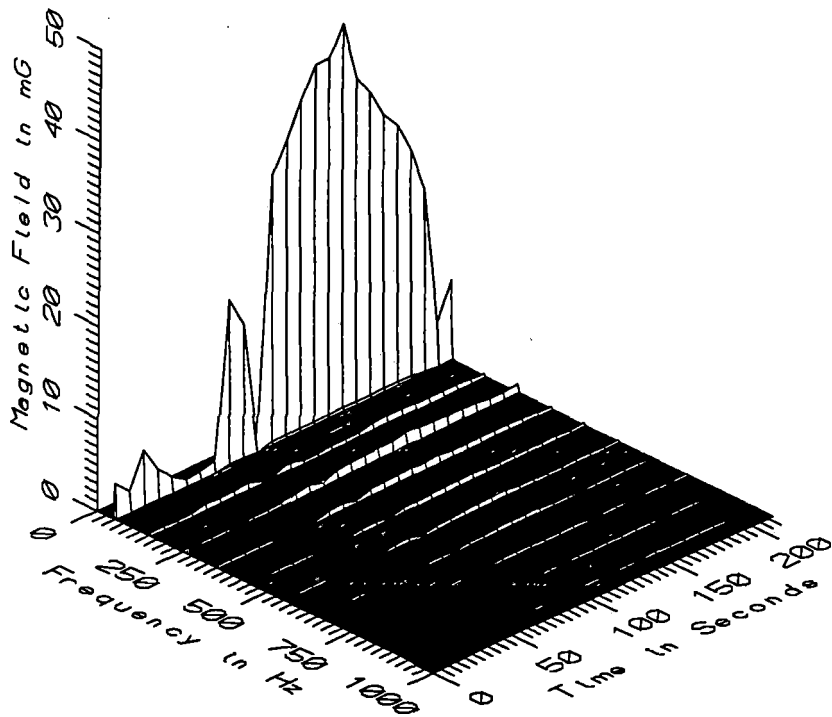

TGV019 - 60cm ABOVE FLOOR AT EDGE OF PLATFORM, VENDOME STATION

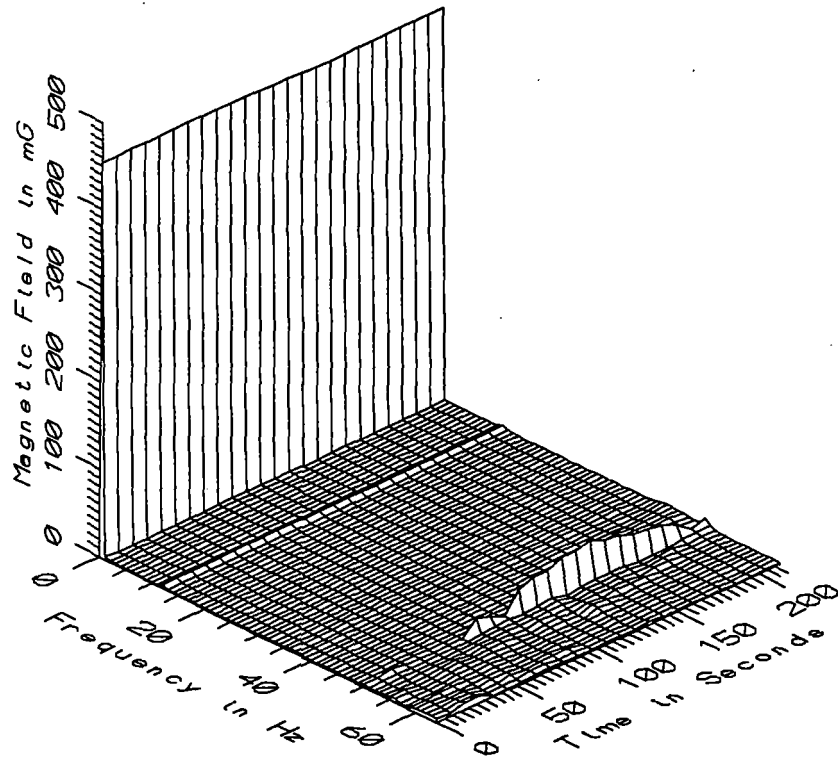

TGV019 - 110cm ABOVE FLOOR AT EDGE OF PLATFORM, VENDOME STATION

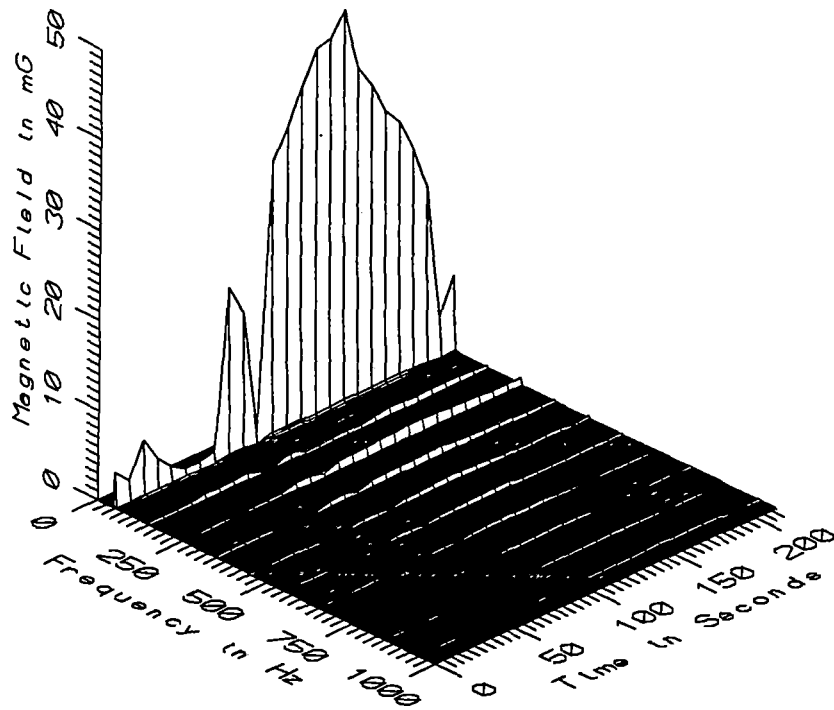

TGV019 - 110cm ABOVE FLOOR AT EDGE OF PLATFORM, VENDOME STATION

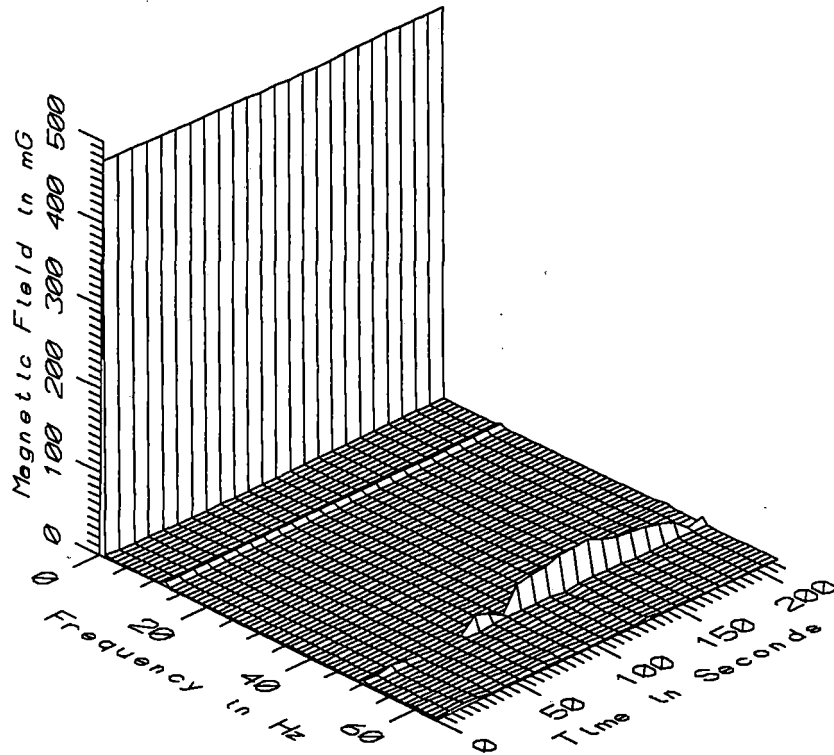

TGV019 - 160cm ABOVE FLOOR AT EDGE OF PLATFORM, VENDOME STATION

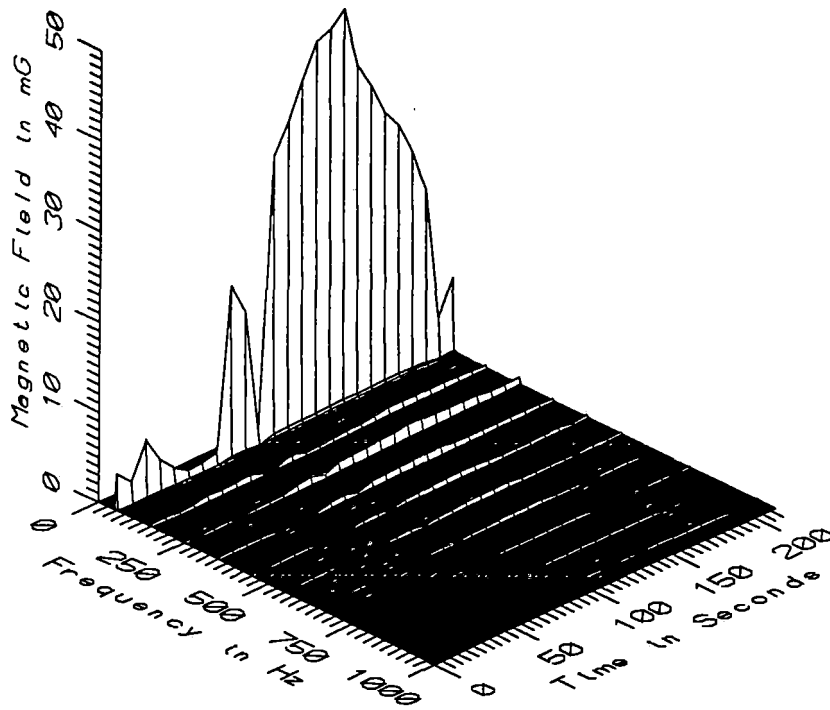

TGV019 - 160cm ABOVE FLOOR AT EDGE OF PLATFORM, VENDOME STATION



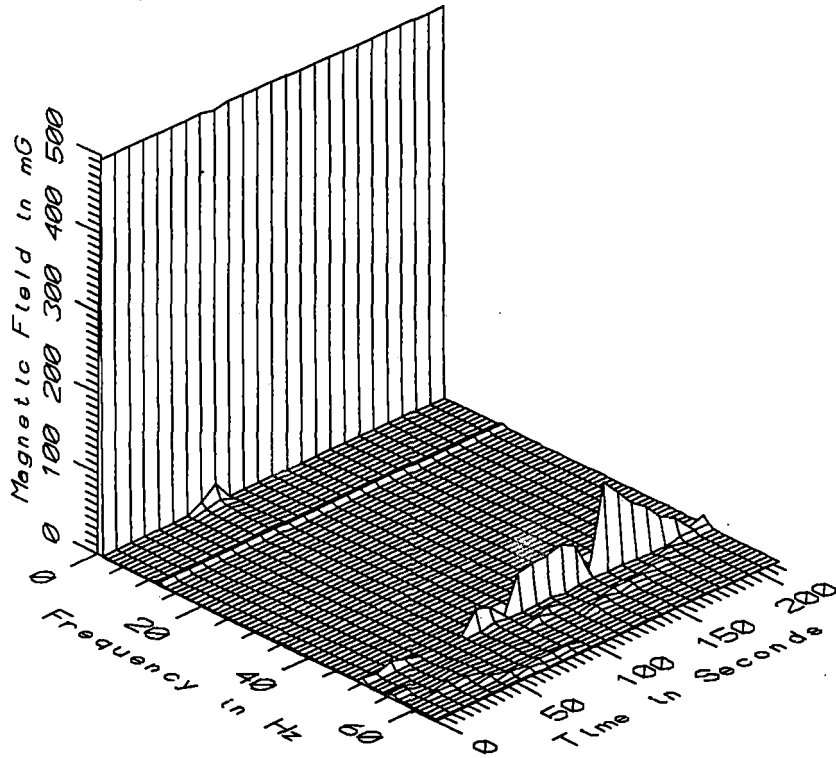

TGV019 - REFERENCE PROBE - 5m FROM EDGE OF PLATFORM, VENDOME STATION

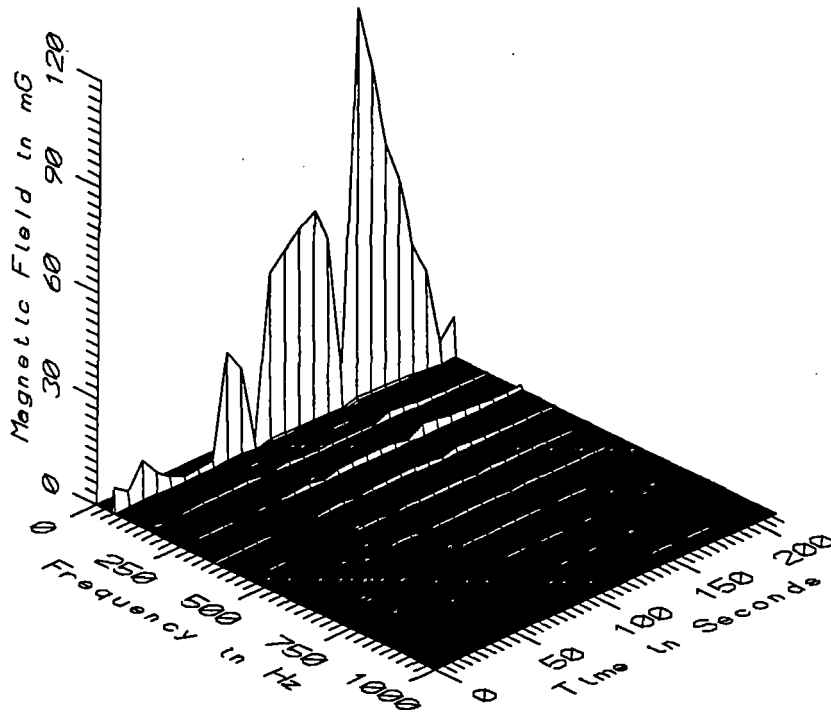

TGV019 - REFERENCE PROBE - 5m FROM EDGE OF PLATFORM, VENDOME STATION

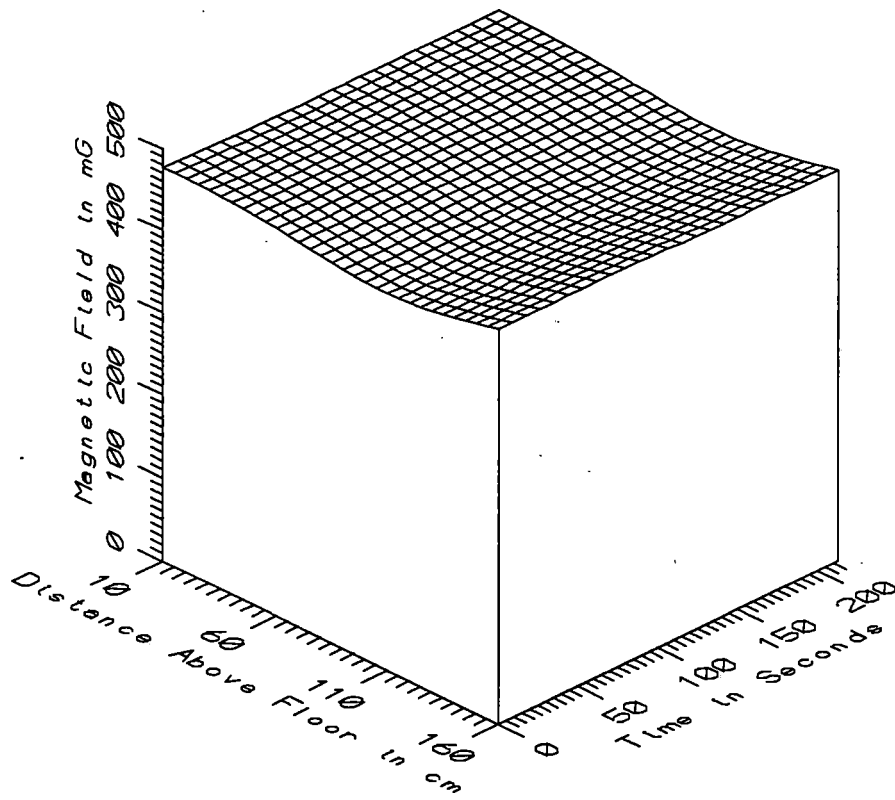

TGV019 - EDGE OF PLATFORM, VENDOME STATION - STATIC

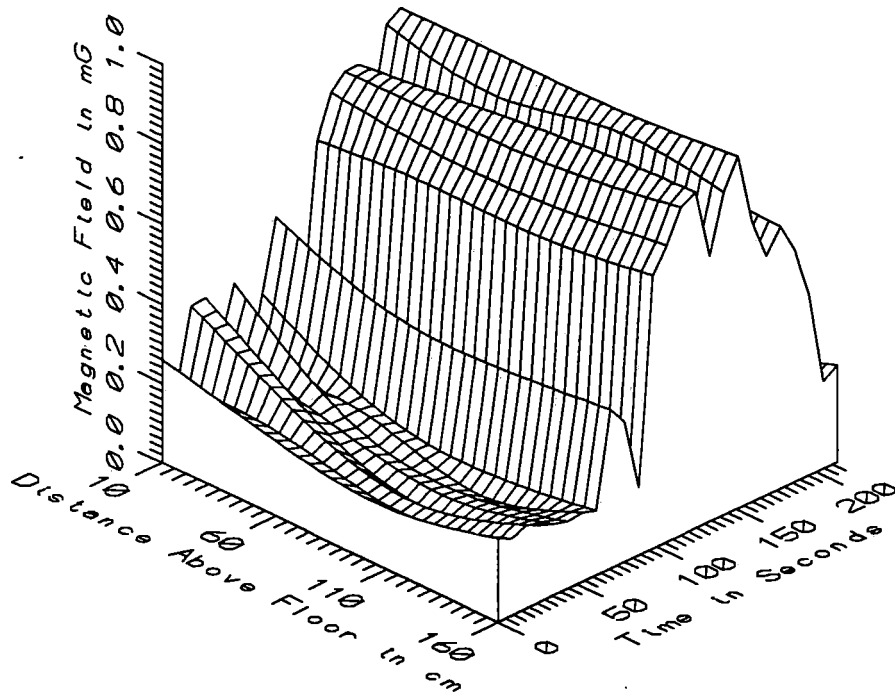

TGV019 - EDGE OF PLATFORM, VENDOME STATION - LOW FREQ, 5-45Hz

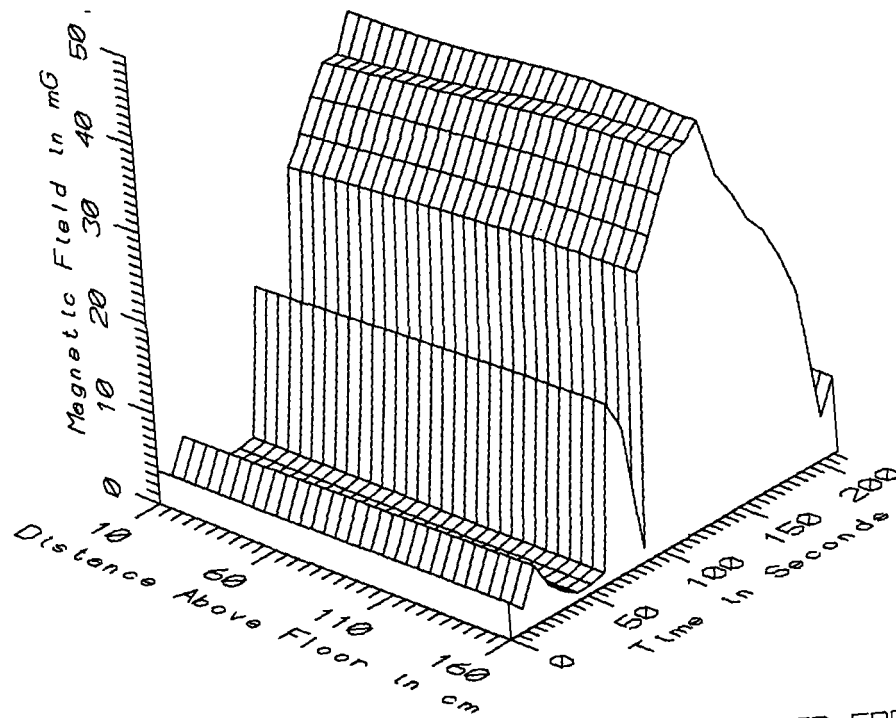

TGV019 - EDGE OF PLATFORM, VENDOME STATION - POWER FREQ, 50-60Hz

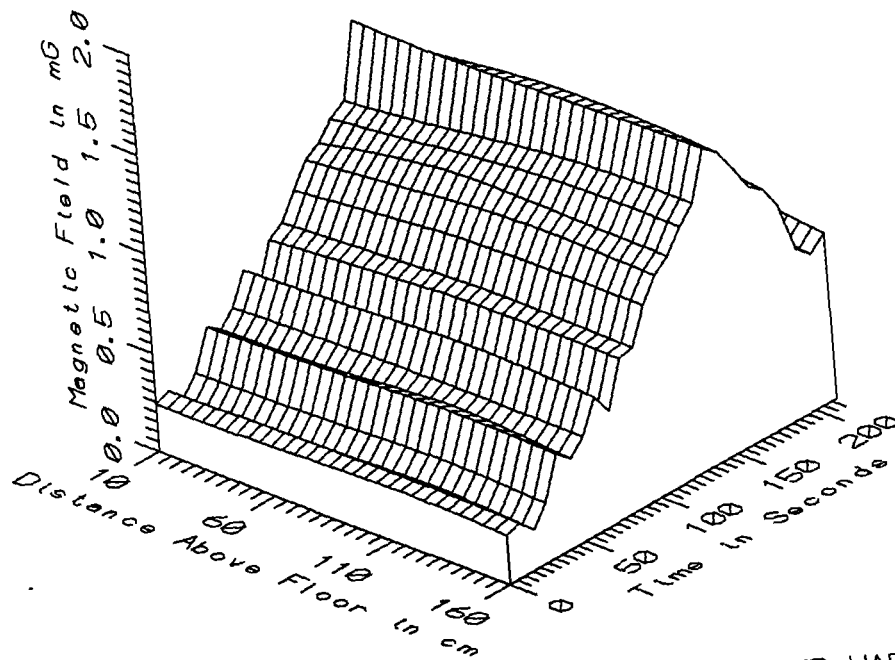

TGV019 - EDGE OF PLATFORM, VENDOME STATION - POWER HARM, 65-300Hz

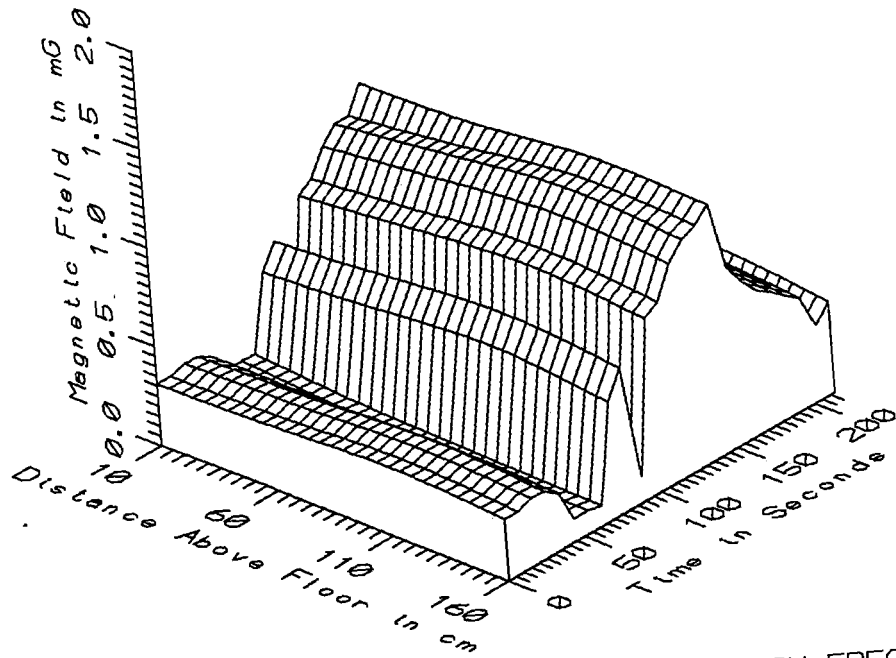

TGV019 - EDGE OF PLATFORM, VENDOME STATION - HIGH FREQ, 305-2560Hz

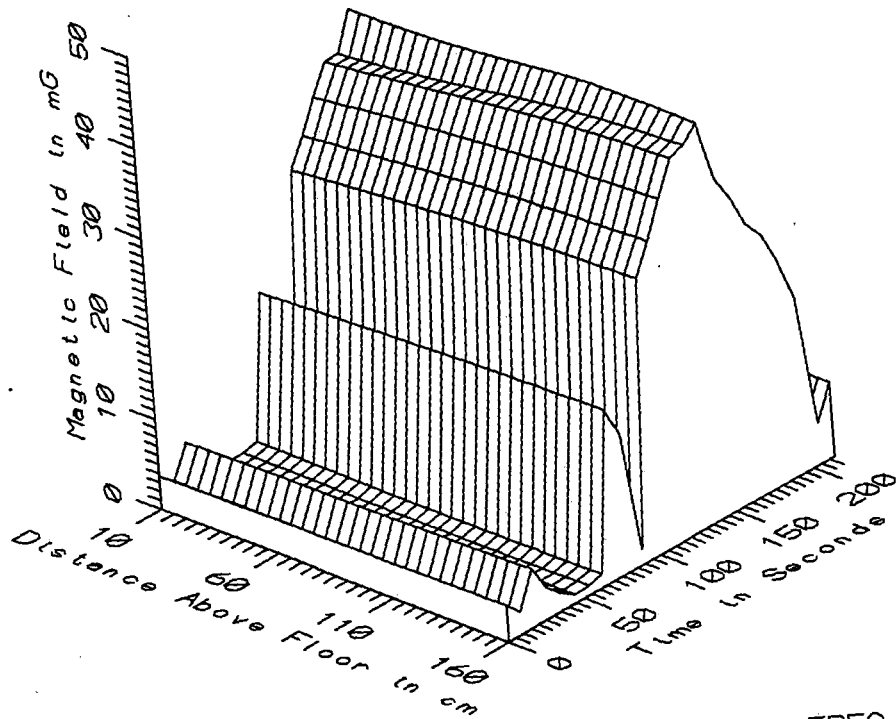

TGV019 - EDGE OF PLATFORM, VENDOME STATION - ALL FREQ, 5-2560Hz

TGV019 - ON VENDOME PLATFORM - TRAIN TO PARIS				TOTAL OF 25 SAMPLES		
FREQUENCY BAND	HEIGHT ABOVE FLOOR (cm)	MINIMUM MAGNETIC FIELD (mG)	MAXIMUM MAGNETIC FIELD (mG)	AVERAGE MAGNETIC FIELD (mG)	STANDARD DEVIATION (mG)	COEFFICIENT OF VARIATION (%)
STATIC	10	476.01	477.00	476.45	0.21	0.04
	60	467.70	468.70	468.18	0.26	0.06
	110	453.11	454.78	454.16	0.45	0.10
	160	473.29	476.59	475.14	0.99	0.21
5-45Hz LOW FREQ	10	0.12	0.85	0.48	0.23	48.38
	60	0.16	0.86	0.44	0.25	58.01
	110	0.10	0.86	0.41	0.29	69.78
	160	0.17	0.89	0.46	0.27	58.29
50-60Hz PWR FREQ	10	0.77	41.41	17.54	14.45	82.37
	60	0.77	42.10	18.29	15.07	82.39
	110	0.81	43.68	18.77	15.60	83.08
	160	0.83	43.83	18.98	15.79	83.19
65-300Hz PWR HARM	10	0.20	1.54	0.83	0.40	47.80
	60	0.21	1.54	0.87	0.41	47.22
	110	0.24	1.57	0.90	0.42	46.35
	160	0.21	1.59	0.87	0.42	47.69
305-2560Hz HIGH FREQ	10	0.18	1.20	0.59	0.31	53.00
	60	0.14	1.23	0.61	0.34	55.80
	110	0.12	1.28	0.64	0.37	57.42
	160	0.10	1.27	0.60	0.36	60.52
5-2560Hz ALL FREQ	10	0.97	41.46	17.61	14.42	81.85
	60	0.92	42.15	18.36	15.04	81.93
	110	0.96	43.73	18.84	15.57	82.63
	160	0.97	43.88	19.04	15.76	82.77

APPENDIX U

DATASET TGV020  
CENTER OF SECOND CLASS COACH R5B

Measurement Setup Code:        Staff: 21        Reference: 24  
   Drawing: A-1

Vehicle Status:                Coach trip from Vendome station to  
   Montparnasse station in Paris

Measurement Date:              September 8, 1992

Measurement Time:              Start:        17:14:10  
   End:         17:16:20

Number of Samples:             22

Programmed Sample Interval:   5 sec

Actual Sample Interval:        6.2 sec

Frequency Spectrum Parameters

<u>Probe Type:</u>	<u>Wideband</u>	<u>Static</u>
Maximum Frequency (Hz)	2560	64
Minimum Frequency (Hz)	5	0
Spectral Bandwidth (Hz)	5	1

Missing or Suspect Data:        None

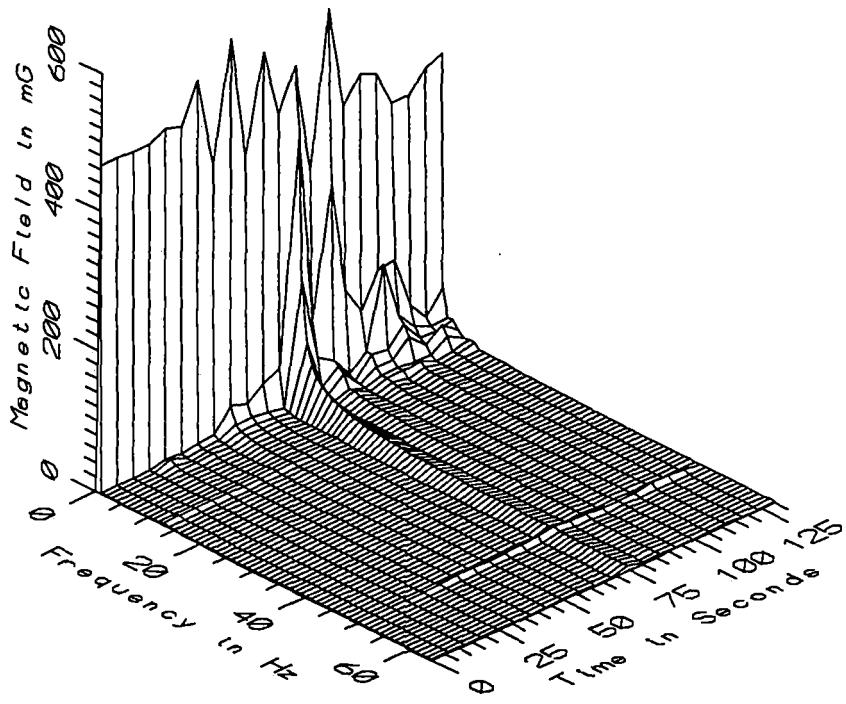

TGV020 - 10cm ABOVE FLOOR NEAR CORNER OF SEAT 47 IN COACH R5B

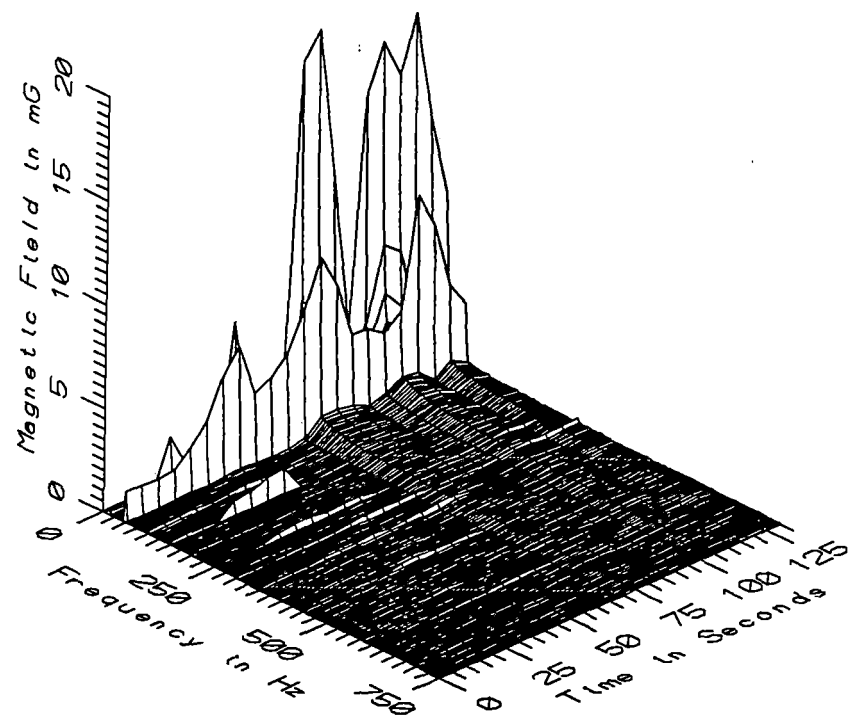

TGV020 - 10cm ABOVE FLOOR NEAR CORNER OF SEAT 47 IN COACH R5B

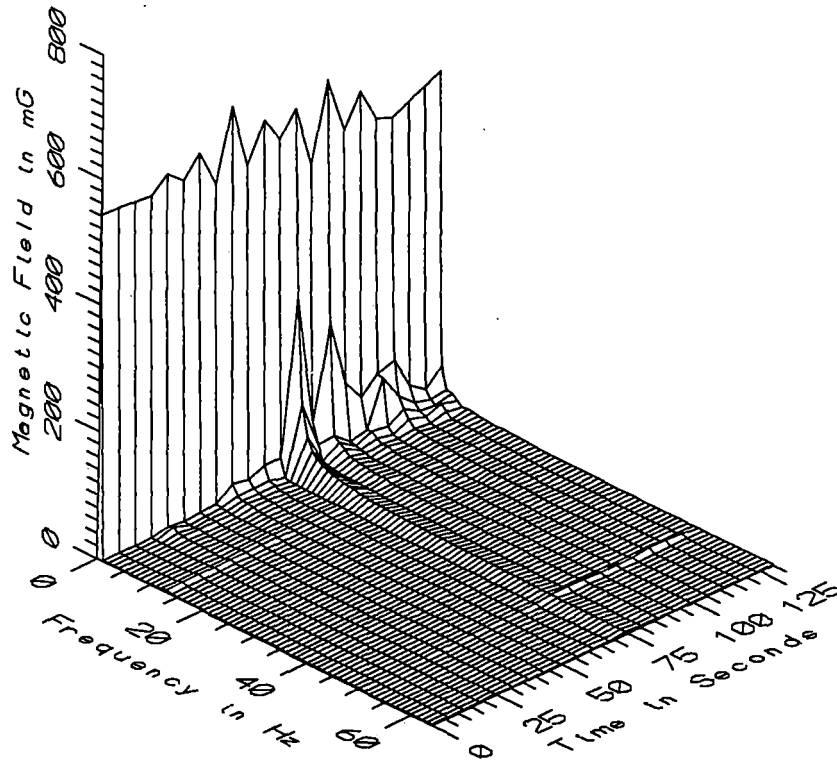

TGV020 - 60cm ABOVE FLOOR NEAR CORNER OF SEAT 47 IN COACH R5B

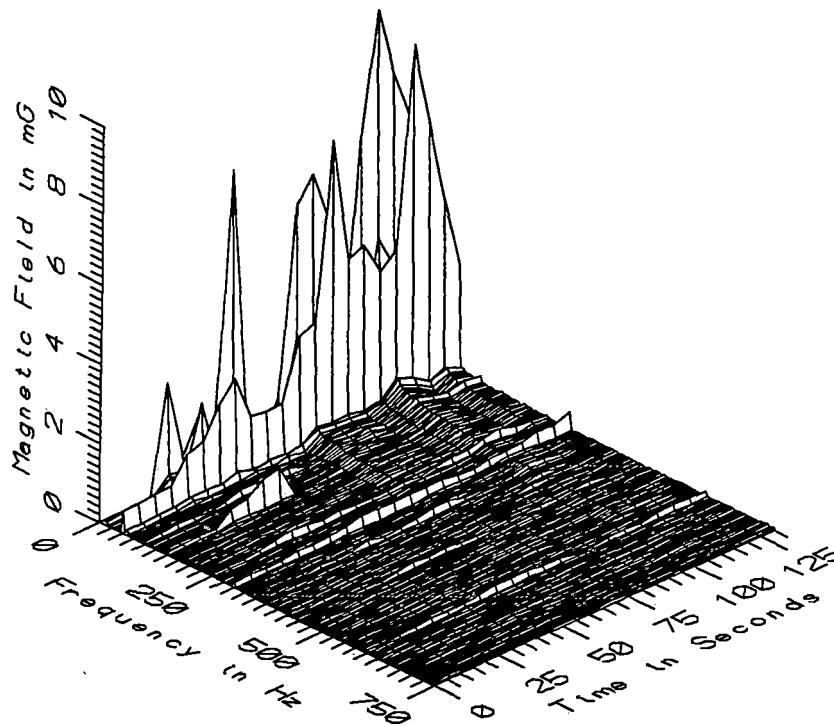

TGV020 - 60cm ABOVE FLOOR NEAR CORNER OF SEAT 47 IN COACH R5B



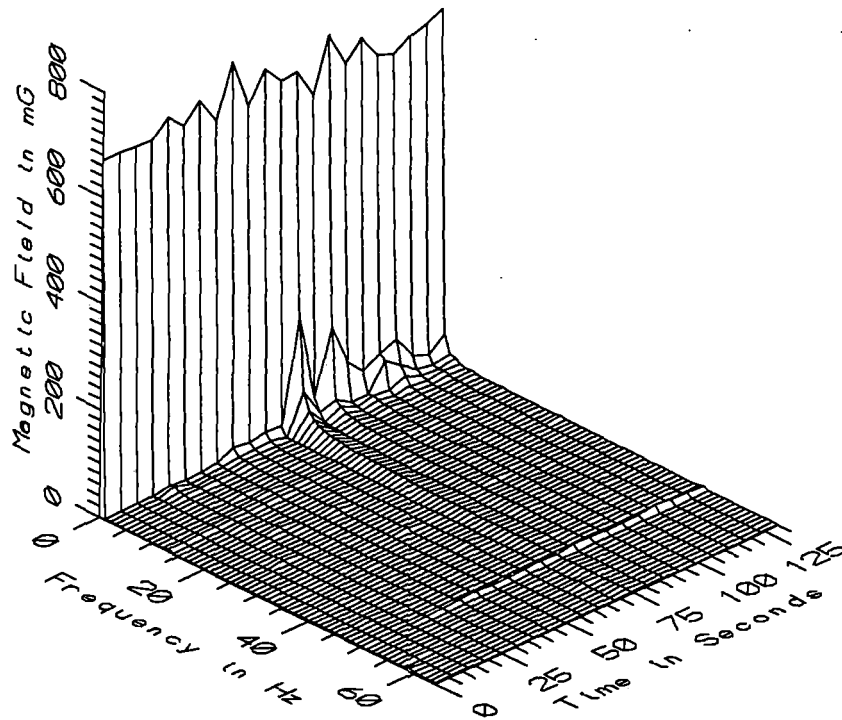

TGV020 - 110cm ABOVE FLOOR NEAR CORNER OF SEAT 47 IN COACH R5B

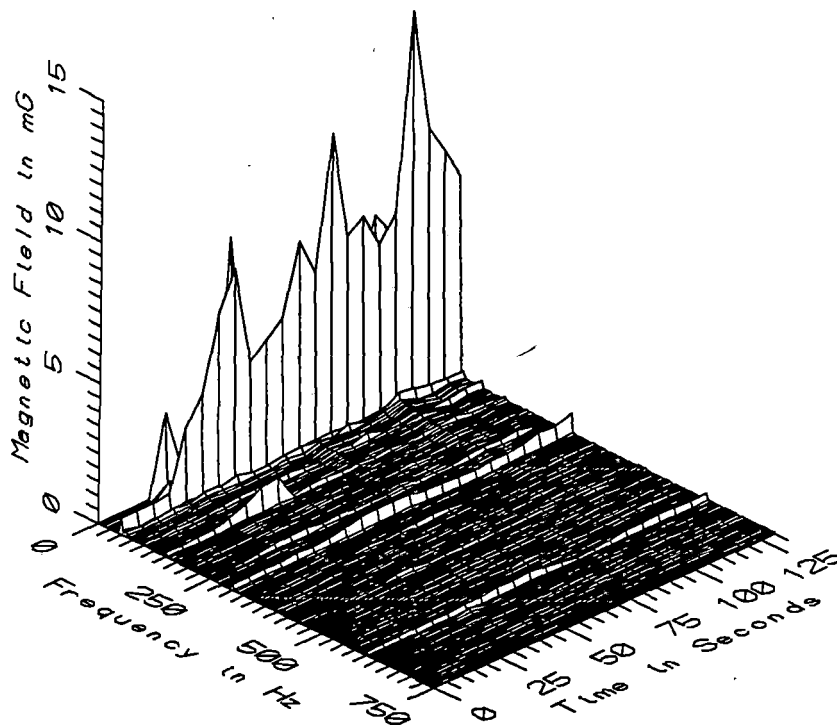

TGV020 - 110cm ABOVE FLOOR NEAR CORNER OF SEAT 47 IN COACH R5B

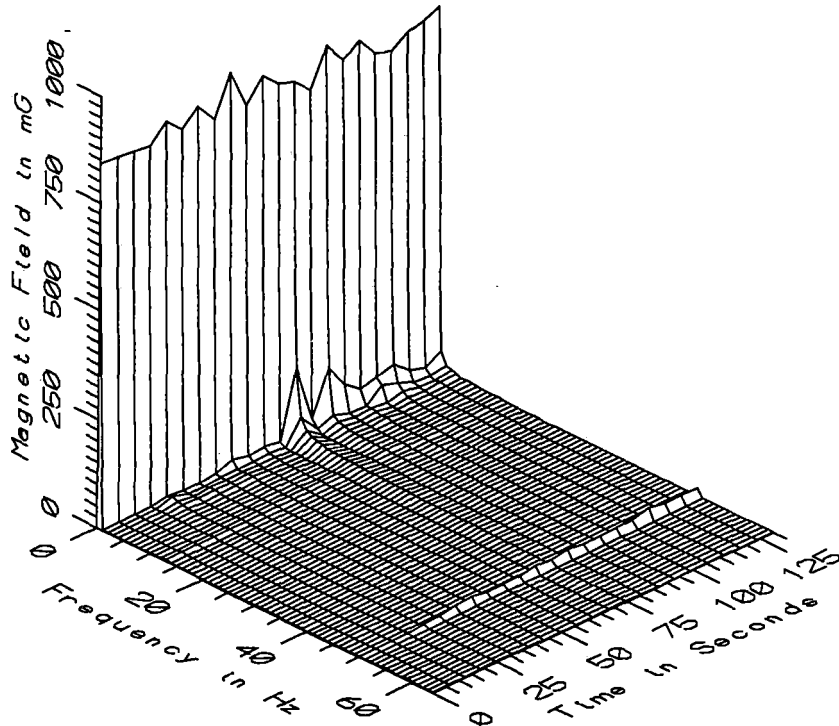

TGV020 - 160cm ABOVE FLOOR NEAR CORNER OF SEAT 47 IN COACH R5B

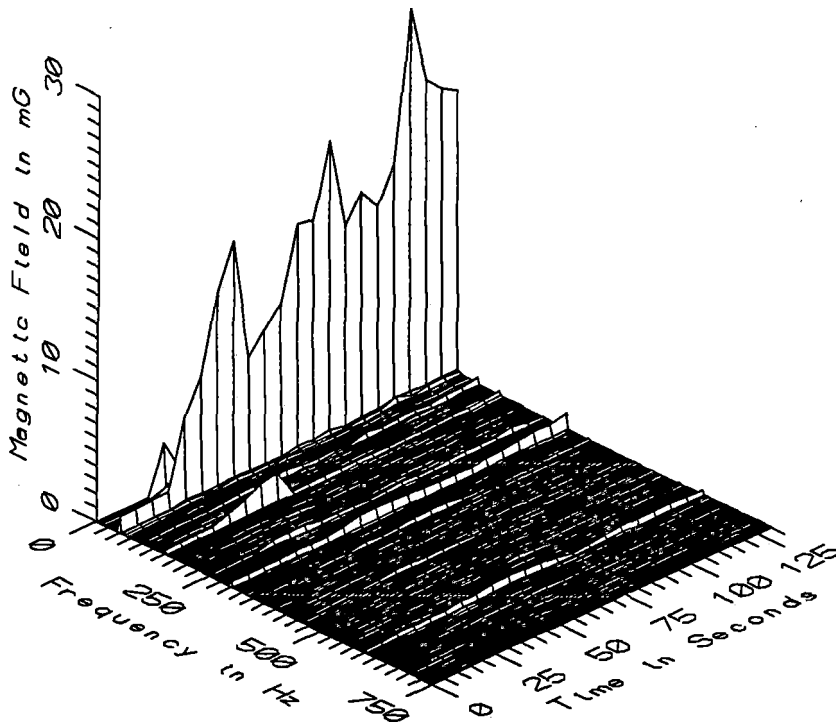

TGV020 - 160cm ABOVE FLOOR NEAR CORNER OF SEAT 47 IN COACH R5B

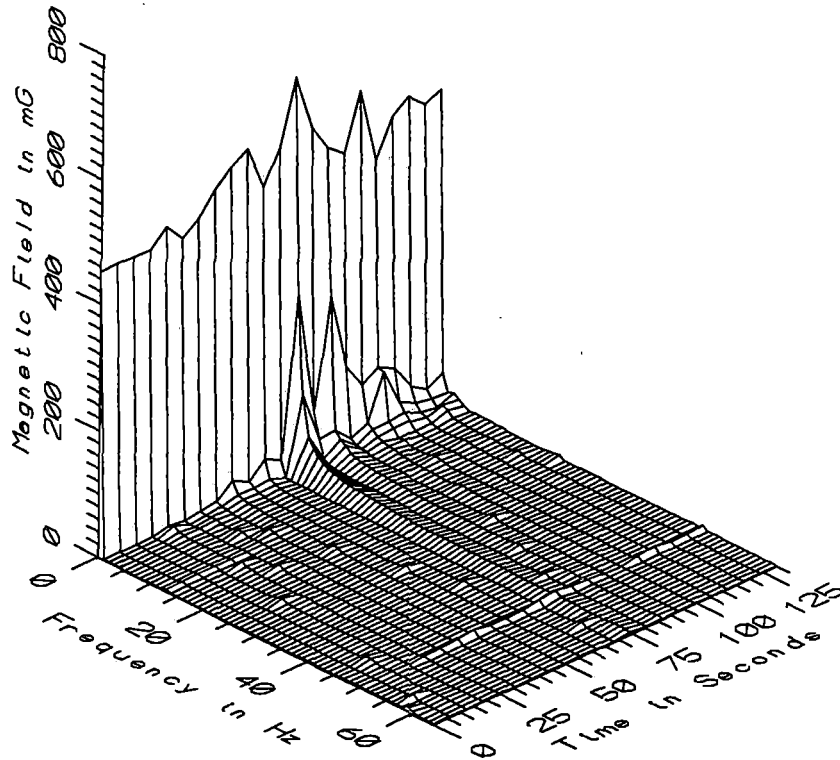

TGV020 - REFERENCE PROBE - ON SEAT 46 IN COACH R5B

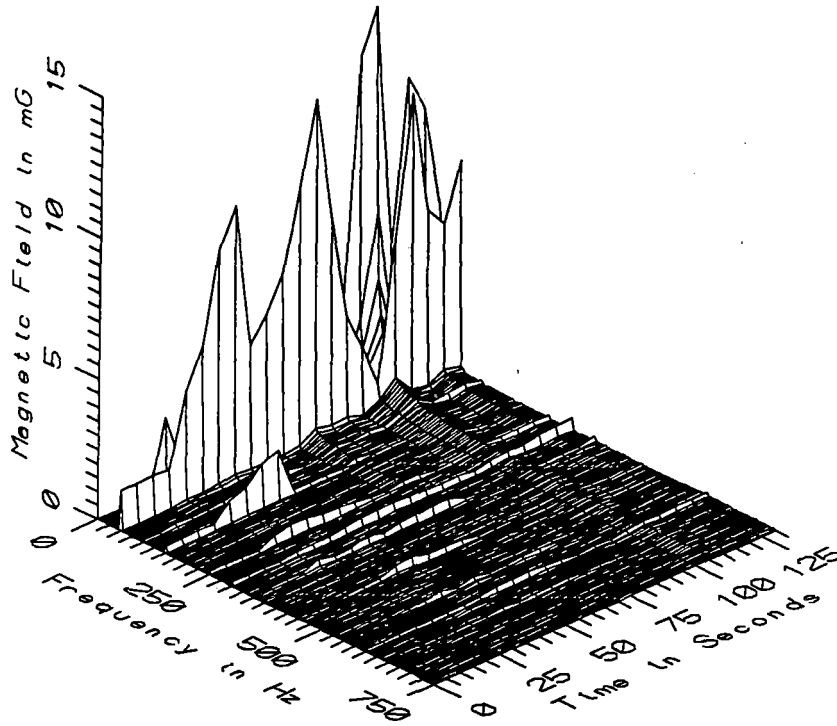

TGV020 - REFERENCE PROBE - ON SEAT 46 IN COACH R5B

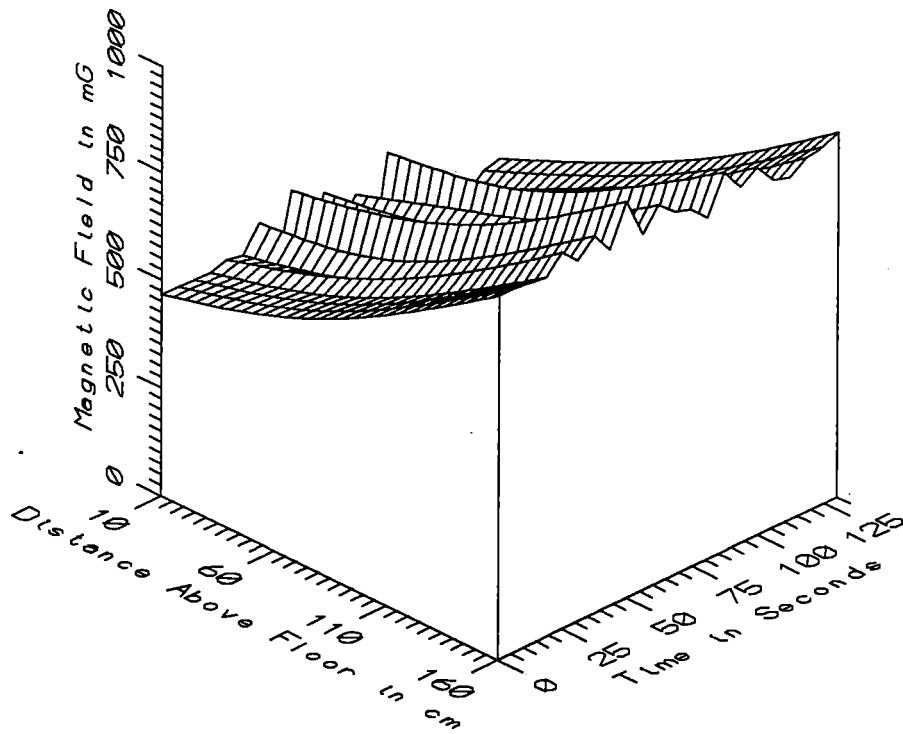

TGV020 - NEAR CORNER OF SEAT 47 IN COACH R5B - STATIC

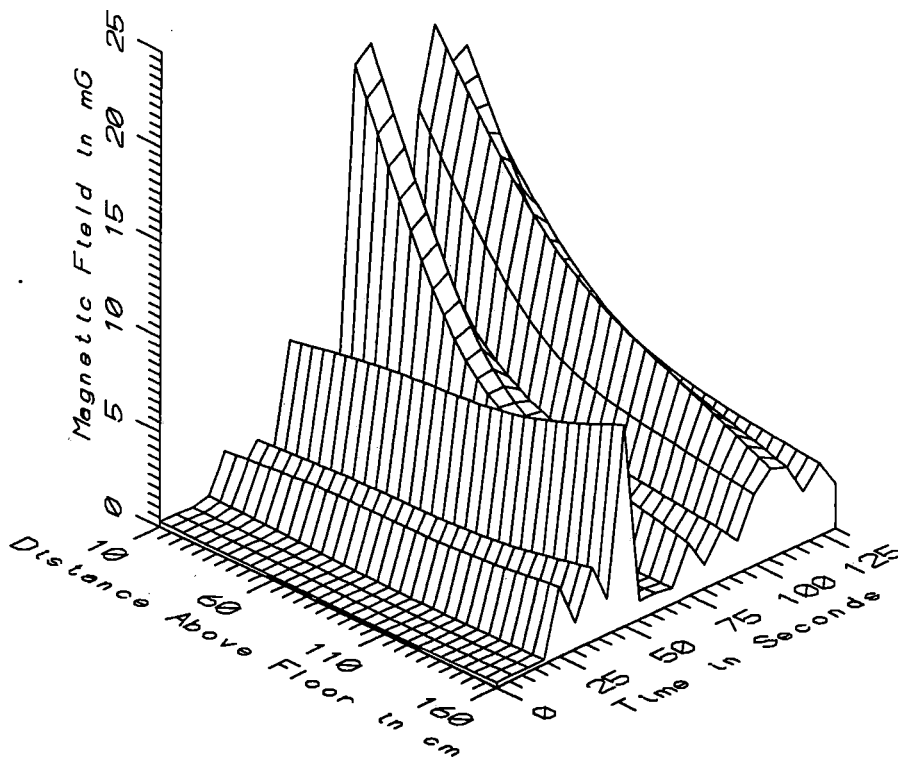

TGV020 - NEAR CORNER OF SEAT 47 IN COACH R5B - LOW FREQ, 5-45Hz

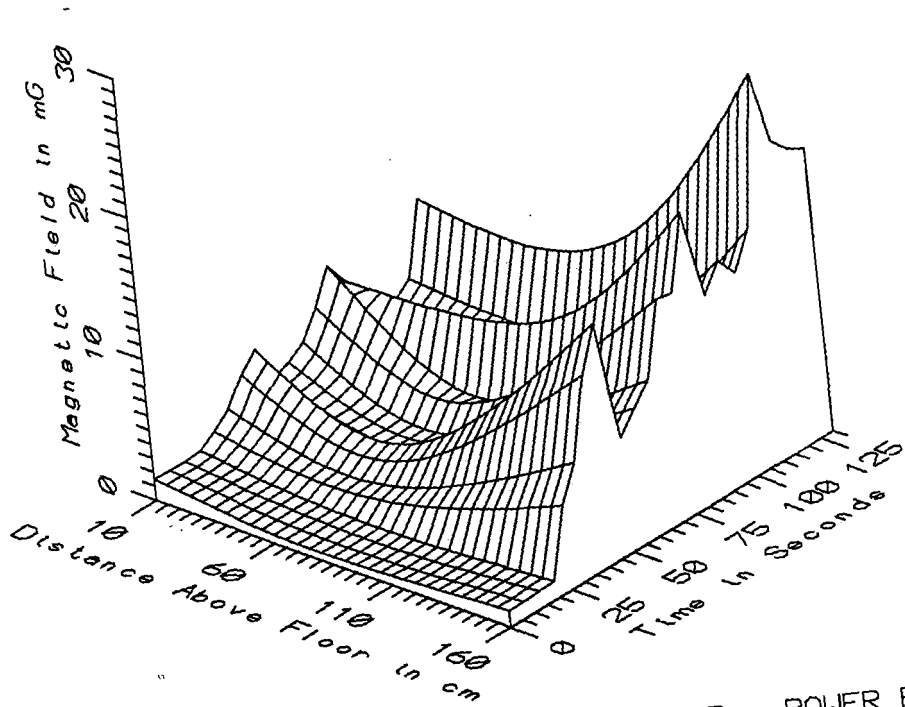

TGV020 - NEAR CORNER OF SEAT 47 IN COACH R5B - POWER FREQ, 50-60Hz

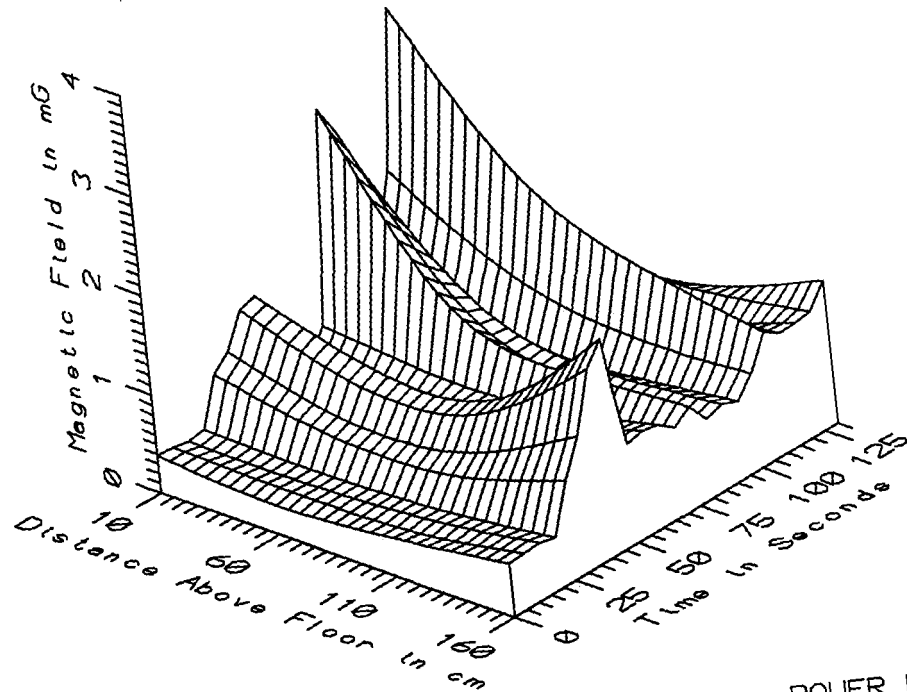

TGV020 - NEAR CORNER OF SEAT 47 IN COACH R5B - POWER HARM, 65-300Hz

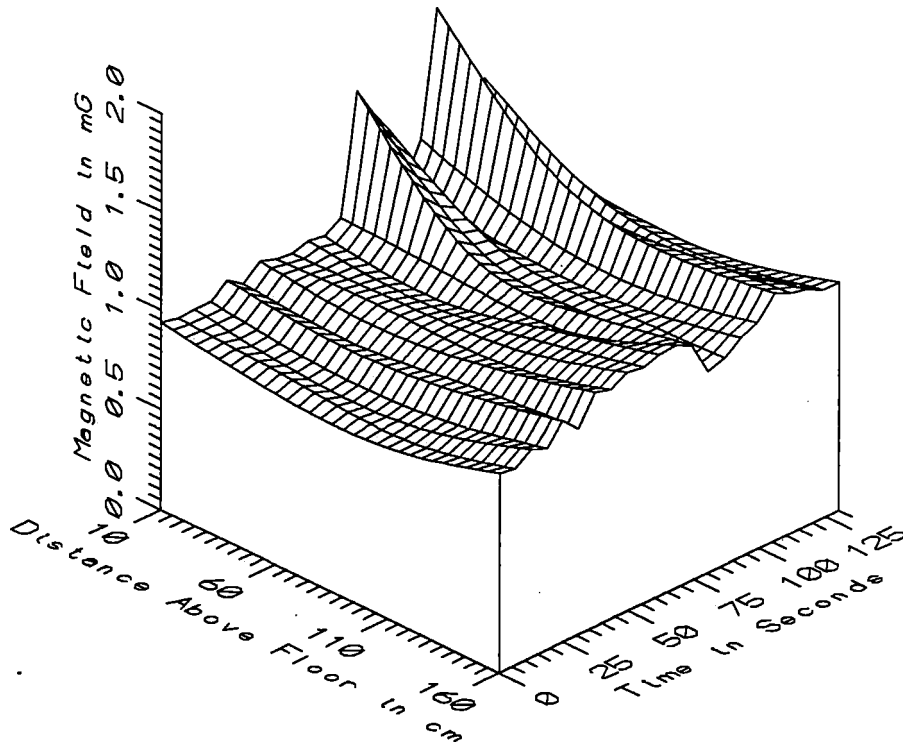

TGV020 - NEAR CORNER OF SEAT 47 IN COACH R5B - HIGH FREQ, 305-2560Hz

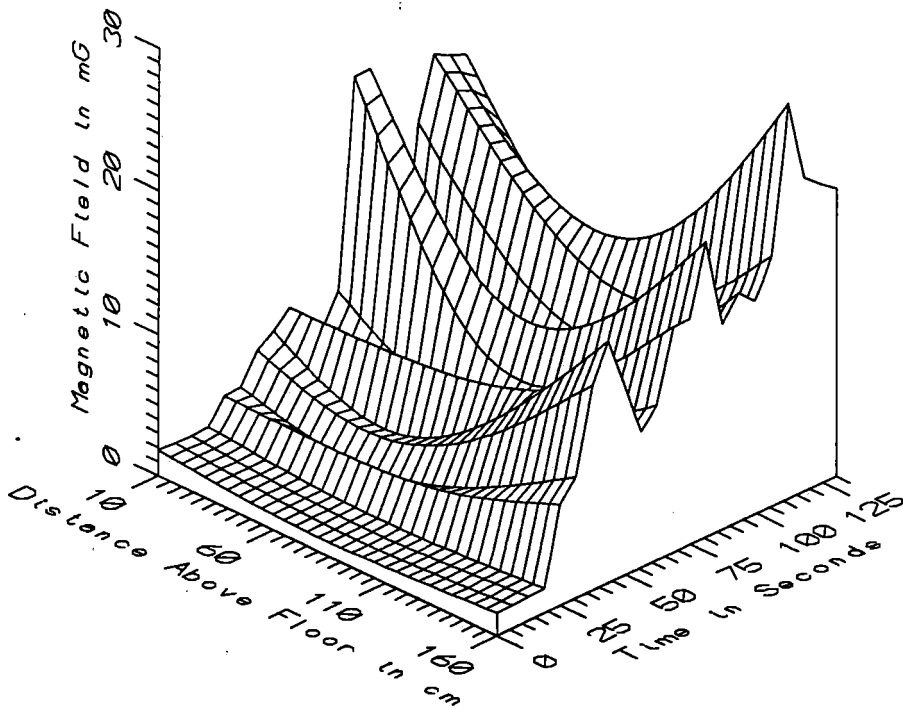

TGV020 - NEAR CORNER OF SEAT 47 IN COACH R5B - ALL FREQ, 5-2560Hz

TGV020 - ALL SAMPLES		TOTAL OF 22 SAMPLES				
FREQUENCY BAND	HEIGHT ABOVE FLOOR (cm)	MINIMUM MAGNETIC FIELD (mG)	MAXIMUM MAGNETIC FIELD (mG)	AVERAGE MAGNETIC FIELD (mG)	STANDARD DEVIATION (mG)	COEFFICIENT OF VARIATION (%)
STATIC	10	324.14	566.54	444.54	62.94	14.16
	60	471.95	624.70	537.35	36.87	6.86
	110	612.27	743.80	666.89	30.82	4.62
	160	791.63	917.86	840.96	29.09	3.46
5-45Hz LOW FREQ	10	0.23	20.16	7.70	7.70	100.06
	60	0.19	11.42	4.02	3.46	86.11
	110	0.12	8.42	2.85	2.42	84.91
	160	0.23	10.74	2.57	2.34	91.33
50-60Hz PWR FREQ	10	1.39	9.43	4.42	2.31	52.27
	60	0.57	8.98	3.05	2.34	76.74
	110	0.59	13.82	5.77	3.43	59.46
	160	1.16	27.38	12.83	7.48	58.34
65-300Hz PWR HARM	10	0.34	3.29	1.27	0.90	71.21
	60	0.30	2.03	0.81	0.42	52.26
	110	0.37	1.53	0.79	0.28	35.80
	160	0.54	2.19	1.08	0.42	39.00
305-2560Hz HIGH FREQ	10	0.92	1.89	1.16	0.28	24.45
	60	0.85	1.34	1.00	0.11	11.37
	110	0.85	1.19	1.01	0.08	8.40
	160	0.98	1.25	1.12	0.08	7.38
5-2560Hz ALL FREQ	10	1.72	21.51	9.70	7.25	74.75
	60	1.08	12.93	5.48	3.83	69.88
	110	1.11	15.29	6.86	3.69	53.88
	160	1.66	27.79	13.46	7.33	54.47

TGV020 - TRAIN AT REST		TOTAL OF 4 SAMPLES				
FREQUENCY BAND	HEIGHT ABOVE FLOOR (cm)	MINIMUM MAGNETIC FIELD (mG)	MAXIMUM MAGNETIC FIELD (mG)	AVERAGE MAGNETIC FIELD (mG)	STANDARD DEVIATION (mG)	COEFFICIENT OF VARIATION (%)
STATIC	10	464.09	466.43	465.23	1.11	0.24
	60	537.92	542.23	540.53	1.94	0.36
	110	664.90	670.08	667.91	2.46	0.37
	160	830.85	840.64	836.82	4.58	0.55
5-45Hz LOW FREQ	10	0.23	0.43	0.31	0.09	28.68
	60	0.19	0.22	0.20	0.01	5.47
	110	0.12	0.16	0.14	0.02	12.83
	160	0.23	0.27	0.25	0.02	7.82
50-60Hz PWR FREQ	10	1.39	1.50	1.46	0.05	3.35
	60	0.57	0.65	0.61	0.04	6.25
	110	0.59	0.71	0.64	0.05	8.21
	160	1.16	1.31	1.23	0.07	5.76
65-300Hz PWR HARM	10	0.34	0.38	0.36	0.02	5.48
	60	0.30	0.34	0.33	0.02	6.42
	110	0.37	0.40	0.39	0.01	3.47
	160	0.54	0.58	0.56	0.02	2.93
305-2560Hz HIGH FREQ	10	0.92	0.94	0.93	0.01	0.75
	60	0.85	0.88	0.86	0.02	1.78
	110	0.85	0.89	0.87	0.02	1.91
	160	0.98	1.04	1.01	0.02	2.37
5-2560Hz ALL FREQ	10	1.72	1.85	1.79	0.06	3.18
	60	1.08	1.15	1.13	0.03	2.62
	110	1.11	1.21	1.16	0.04	3.47
	160	1.66	1.76	1.70	0.06	3.31



TGV020 - AC SECTION ONLY			TOTAL OF 18 SAMPLES			
FREQUENCY BAND	HEIGHT ABOVE FLOOR (cm)	MINIMUM MAGNETIC FIELD (mG)	MAXIMUM MAGNETIC FIELD (mG)	AVERAGE MAGNETIC FIELD (mG)	STANDARD DEVIATION (mG)	COEFFICIENT OF VARIATION (%)
STATIC	10	324.14	566.54	439.95	69.07	15.70
	60	471.95	624.70	536.64	40.93	7.63
	110	612.27	743.80	666.67	34.23	5.13
	160	791.63	917.86	841.87	32.20	3.82
5-45Hz LOW FREQ	10	0.88	20.16	9.34	7.59	81.23
	60	0.67	11.42	4.87	3.26	66.89
	110	0.73	8.42	3.46	2.26	65.54
	160	0.85	10.74	3.08	2.29	74.36
50-60Hz PWR FREQ	10	2.20	9.43	5.08	2.02	39.74
	60	1.25	8.98	3.59	2.25	62.61
	110	2.75	13.82	6.91	2.64	38.20
	160	6.00	27.38	15.40	5.52	35.84
65-300Hz PWR HARM	10	0.43	3.29	1.47	0.88	59.78
	60	0.48	2.03	0.92	0.39	42.74
	110	0.64	1.53	0.88	0.23	26.11
	160	0.80	2.19	1.19	0.38	31.52
305-2560Hz HIGH FREQ	10	0.94	1.89	1.21	0.29	23.91
	60	0.91	1.34	1.03	0.10	9.90
	110	0.97	1.19	1.04	0.06	5.31
	160	1.01	1.25	1.15	0.07	5.95
5-2560Hz ALL FREQ	10	3.47	21.51	11.46	6.85	59.81
	60	1.86	12.93	6.45	3.56	55.18
	110	4.07	15.29	8.12	2.74	33.74
	160	7.23	27.79	16.07	5.16	32.13

APPENDIX V

DATASET TGV021  
CENTER OF SECOND CLASS COACH R5B

Measurement Setup Code:           Staff: 21       Reference: 24  
  Drawing: A-1

Vehicle Status:                   Coach trip from Vendome station to  
  Montparnasse station in Paris

Measurement Date:                September 8, 1992

Measurement Time:                Start:       17:17:06  
  End:         17:26:55

Number of Samples:               63

Programmed Sample Interval:     5 sec

Actual Sample Interval:         9.5 sec

Frequency Spectrum Parameters

<u>Probe Type:</u>	<u>Wideband</u>	<u>Static</u>
Maximum Frequency (Hz)	2560	64
Minimum Frequency (Hz)	5	0
Spectral Bandwidth (Hz)	5	1

Missing or Suspect Data:       None

# TRAIN SPEED - TGV021

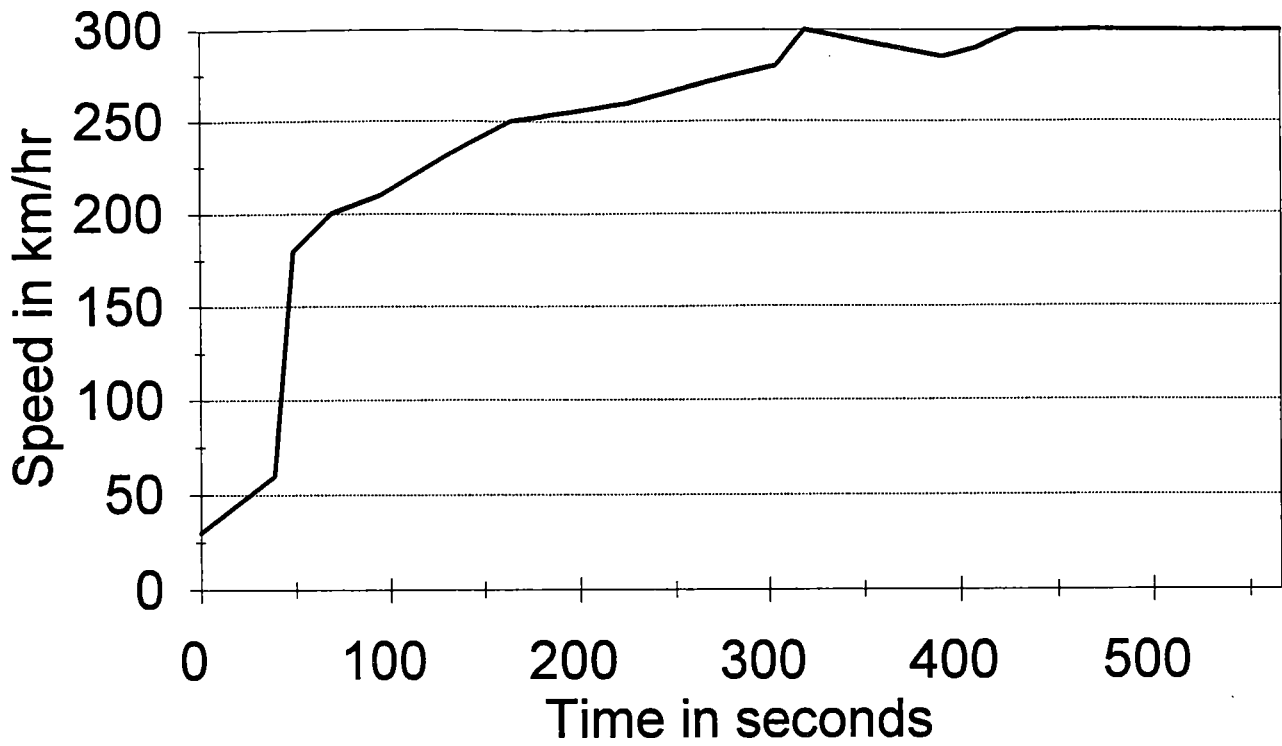

# TRAIN SPEED - TGV021

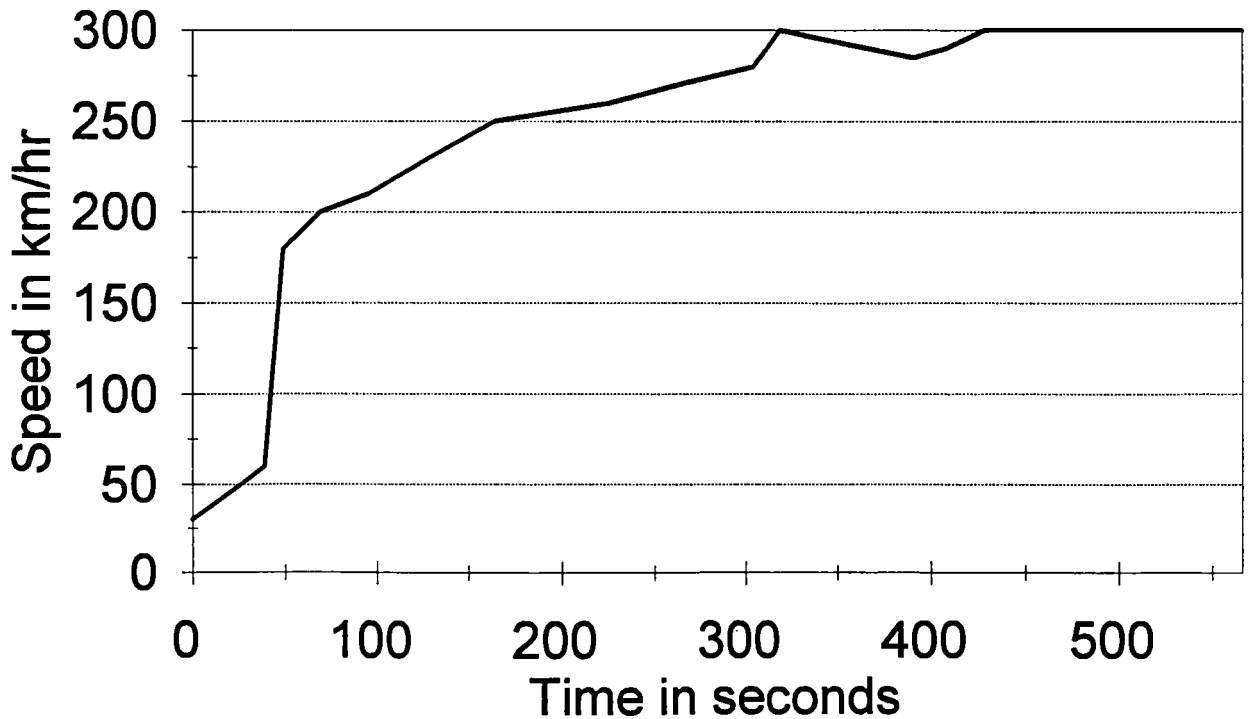

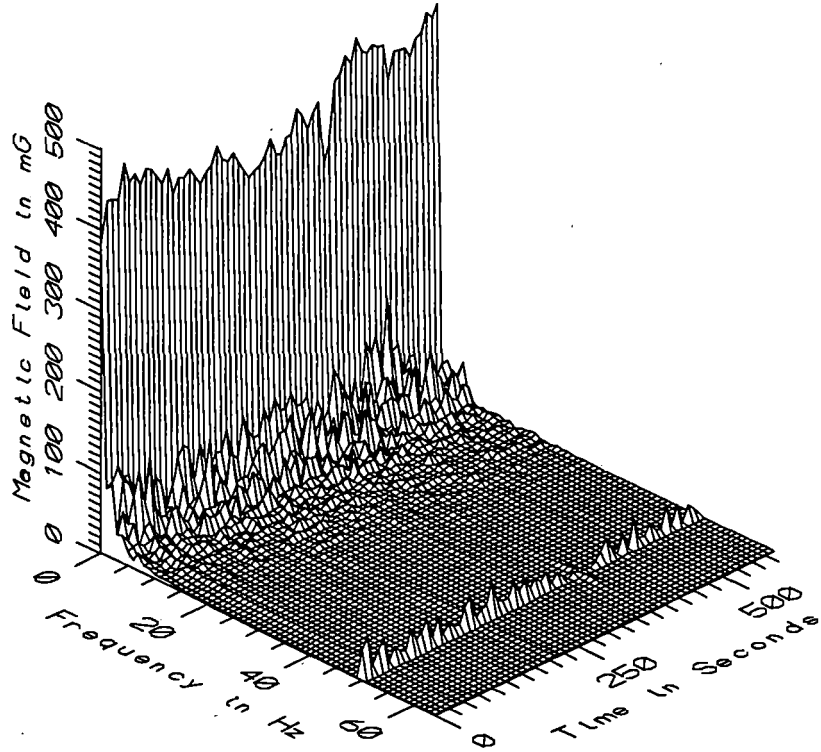

TGV021 - 10<sub>cm</sub> ABOVE FLOOR NEAR CORNER OF SEAT 47 IN COACH R5B

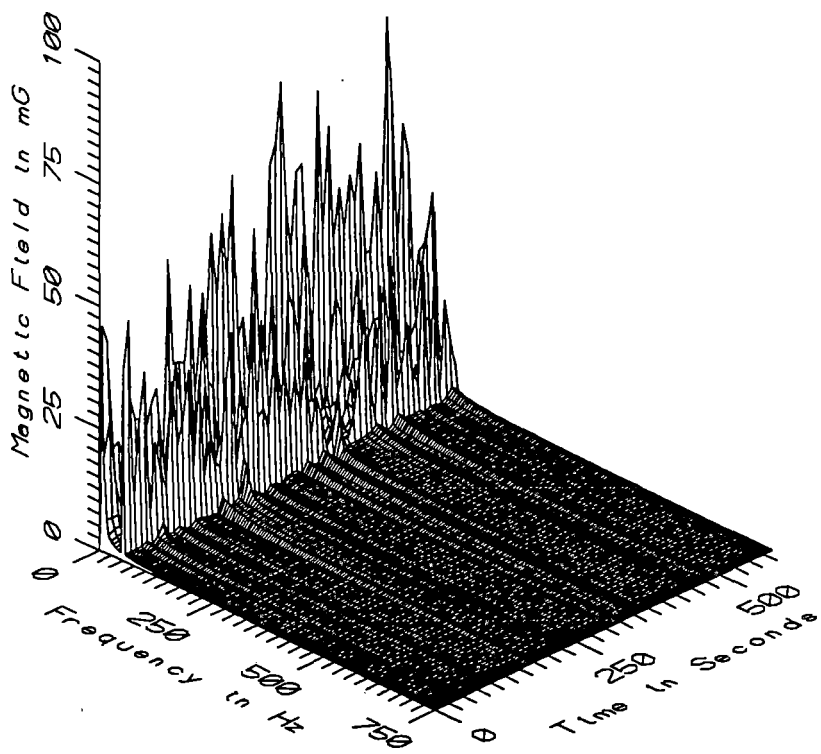

TGV021 - 10<sub>cm</sub> ABOVE FLOOR NEAR CORNER OF SEAT 47 IN COACH R5B

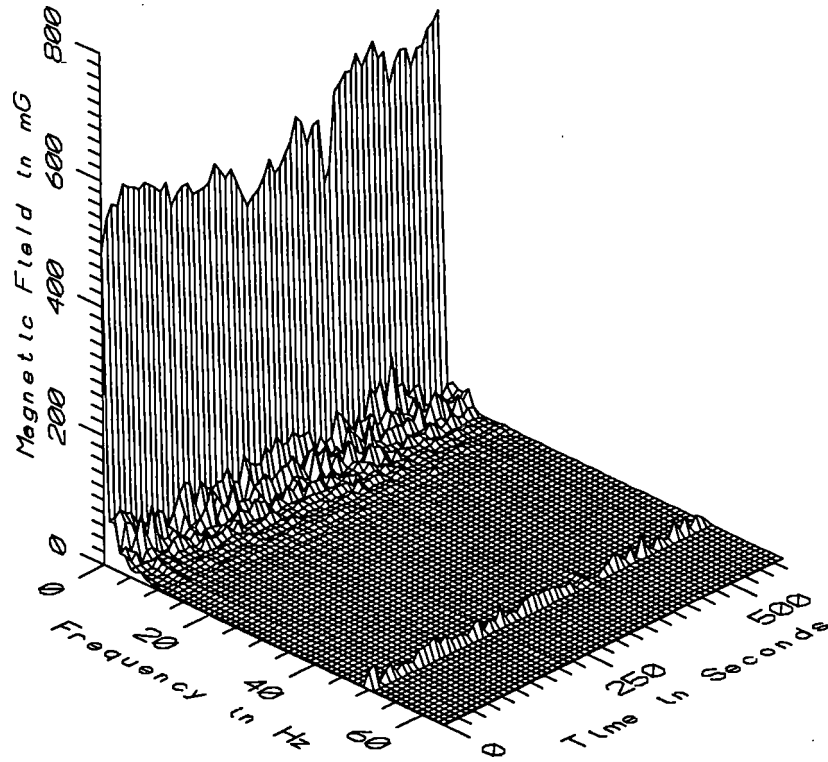

TGV021 - 60cm ABOVE FLOOR NEAR CORNER OF SEAT 47 IN COACH R5B

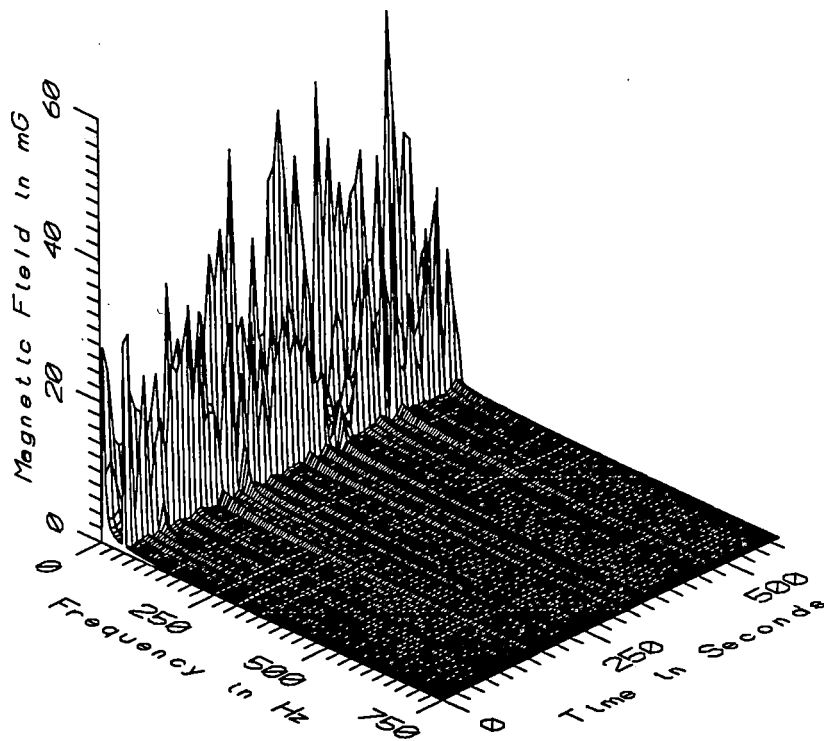

TGV021 - 60cm ABOVE FLOOR NEAR CORNER OF SEAT 47 IN COACH R5B

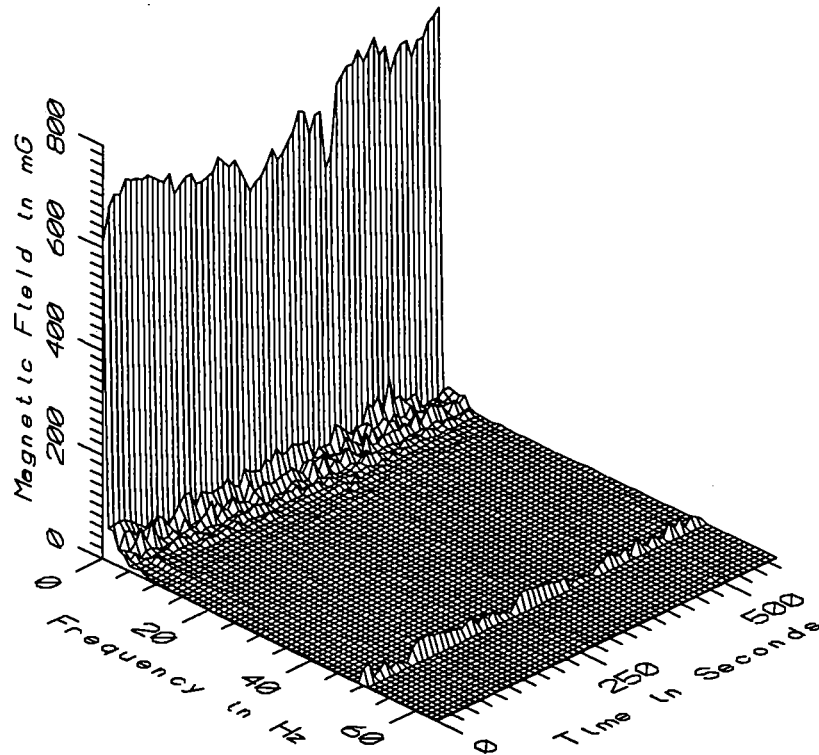

TGV021 - 110cm ABOVE FLOOR NEAR CORNER OF SEAT 47 IN COACH R5B

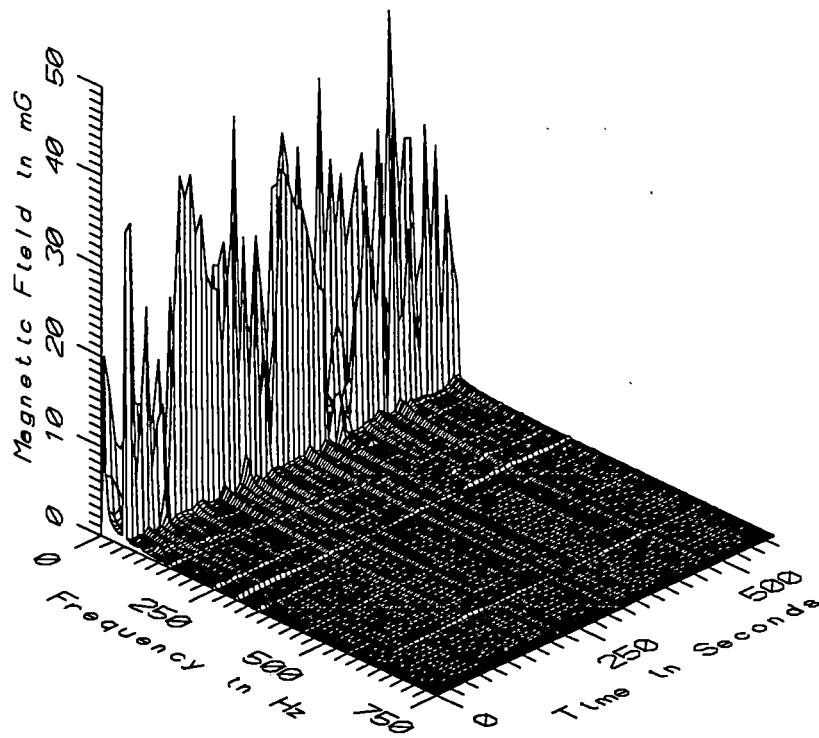

TGV021 - 110cm ABOVE FLOOR NEAR CORNER OF SEAT 47 IN COACH R5B

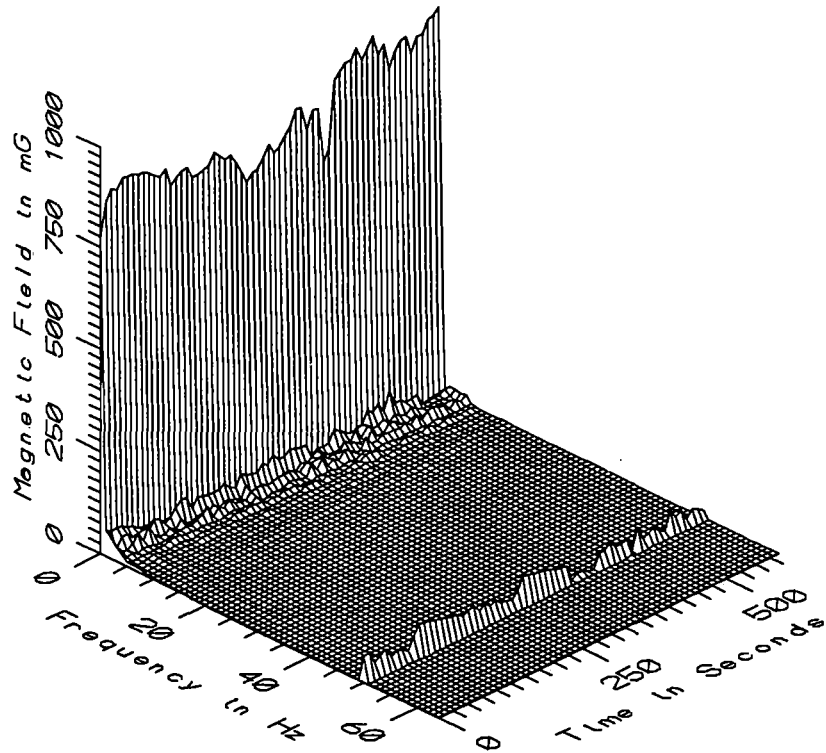

TGV021 - 160cm ABOVE FLOOR NEAR CORNER OF SEAT 47 IN COACH R5B

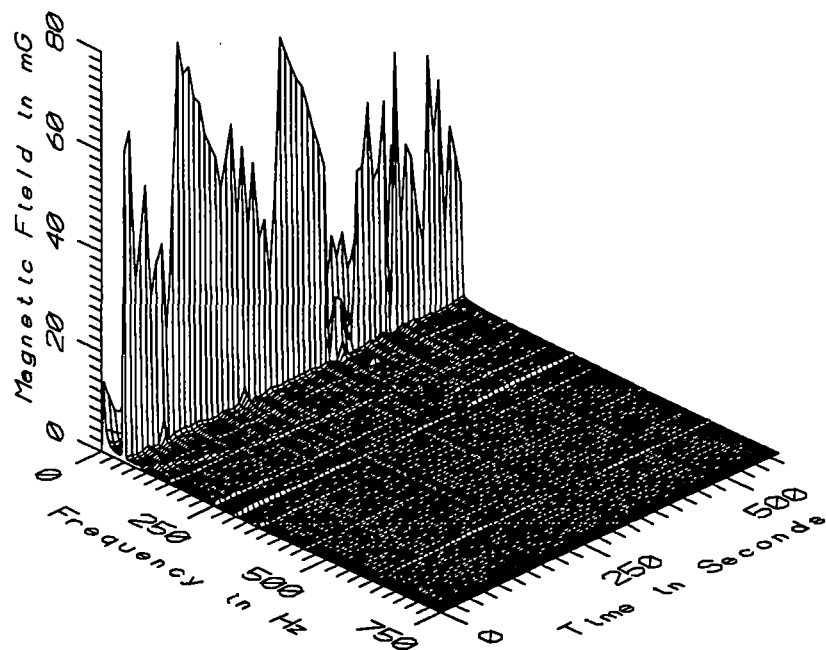

TGV021 - 160cm ABOVE FLOOR NEAR CORNER OF SEAT 47 IN COACH R5B

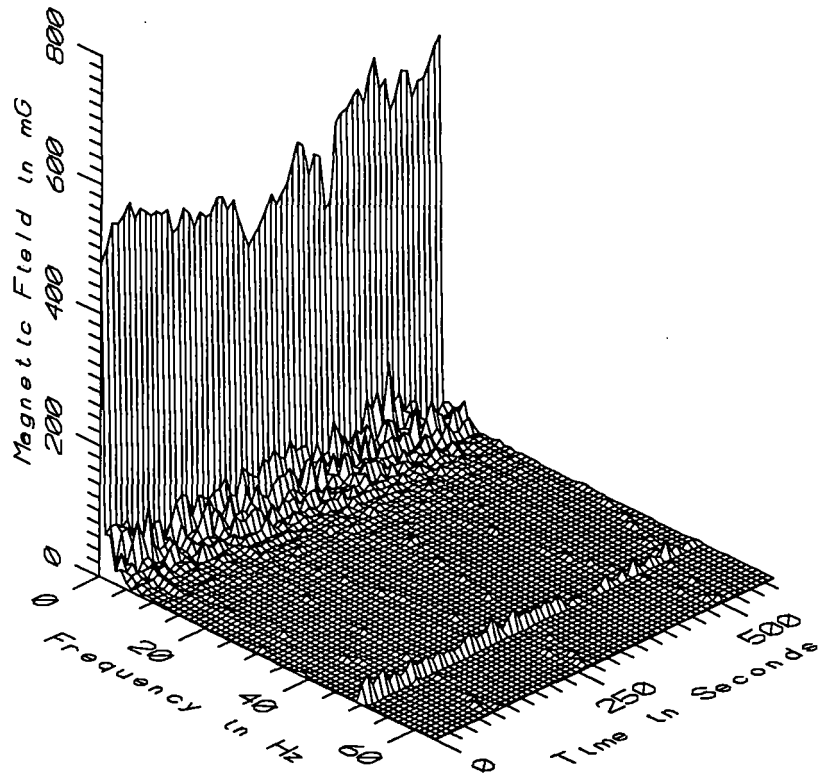

TGV021 - REFERENCE PROBE - ON SEAT 46 IN COACH R5B

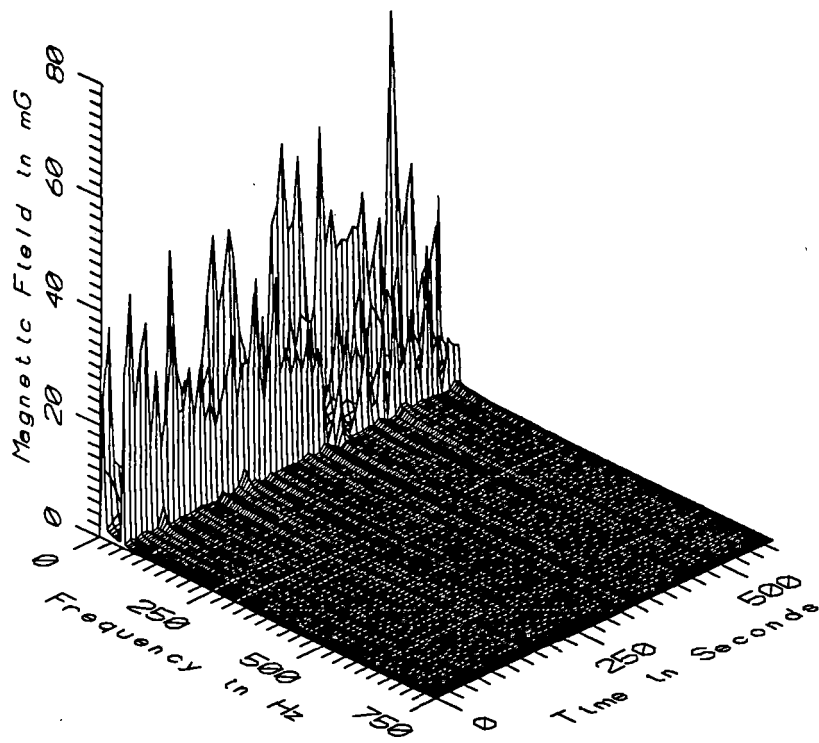

TGV021 - REFERENCE PROBE - ON SEAT 46 IN COACH R5B



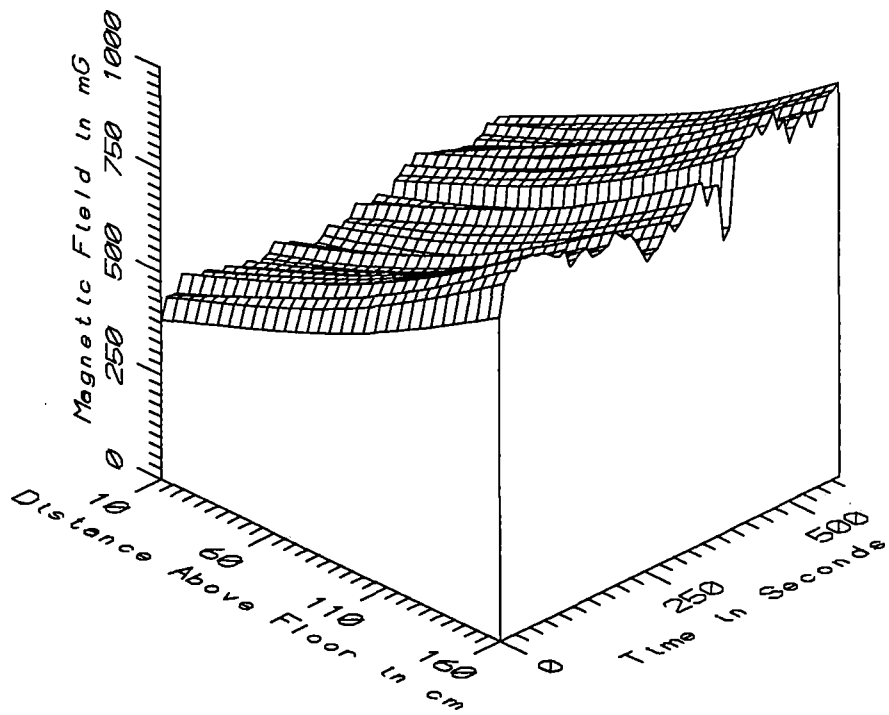

TGV021 - NEAR CORNER OF SEAT 47 IN COACH R5B - STATIC

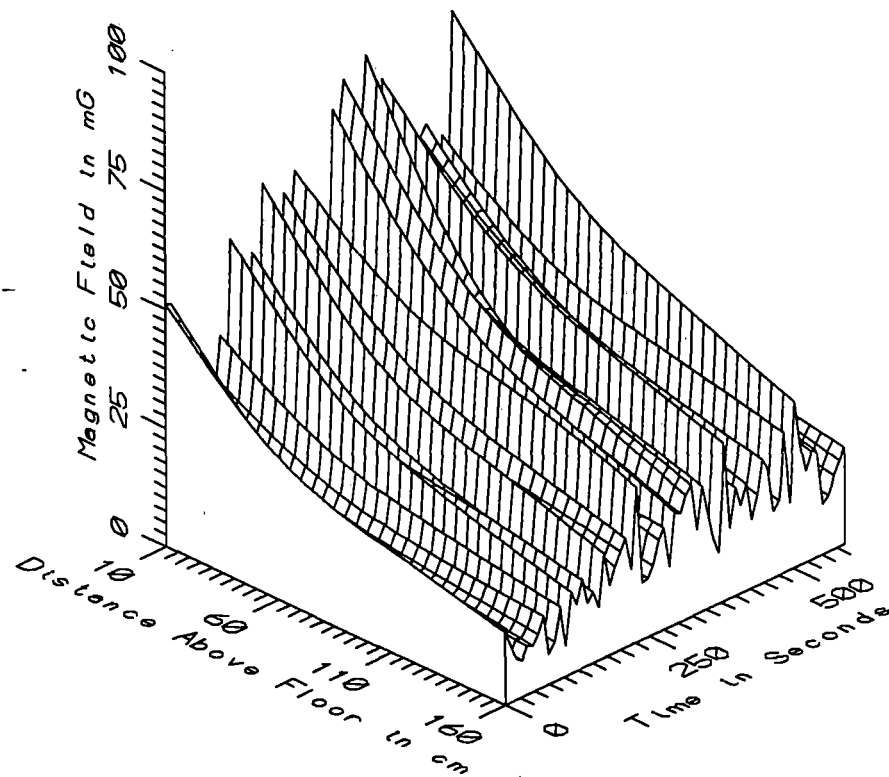

TGV021 - NEAR CORNER OF SEAT 47 IN COACH R5B - LOW FREQ, 5-45Hz

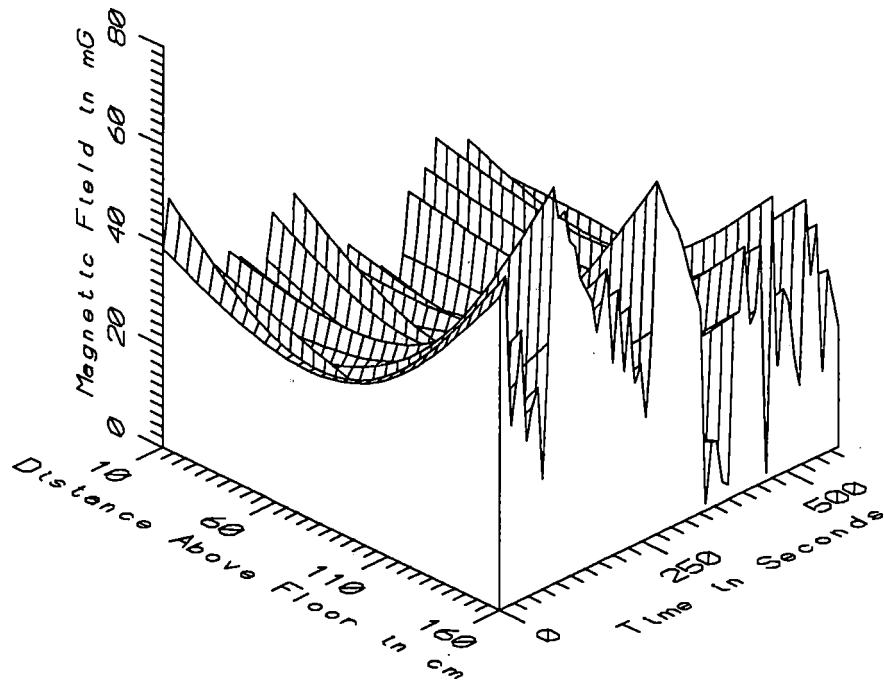

TGV021 - NEAR CORNER OF SEAT 47 IN COACH R5B - POWER FREQ, 50-60Hz

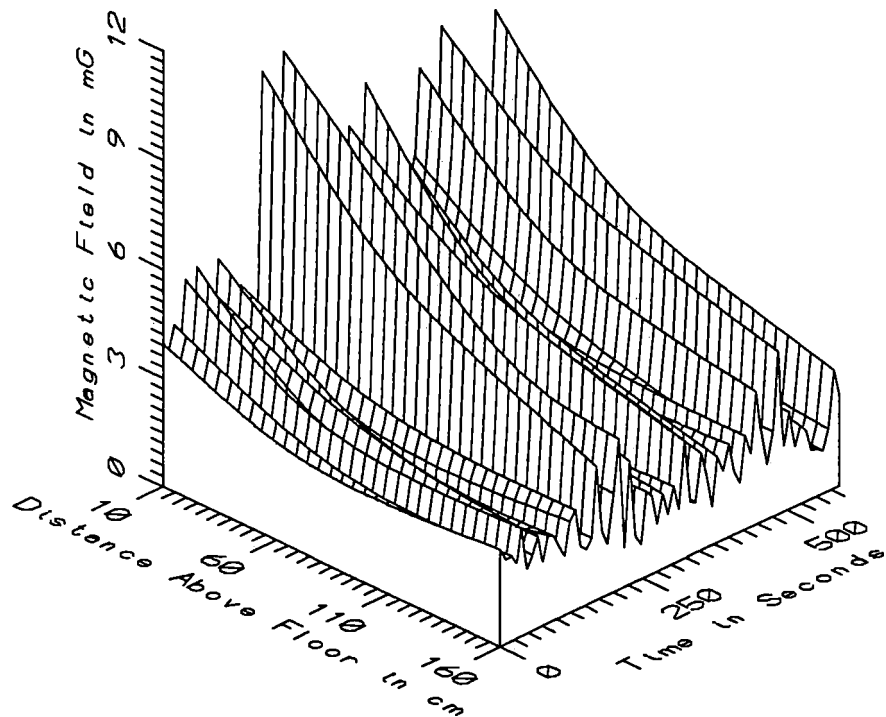

TGV021 - NEAR CORNER OF SEAT 47 IN COACH R5B - POWER HARM, 65-300Hz

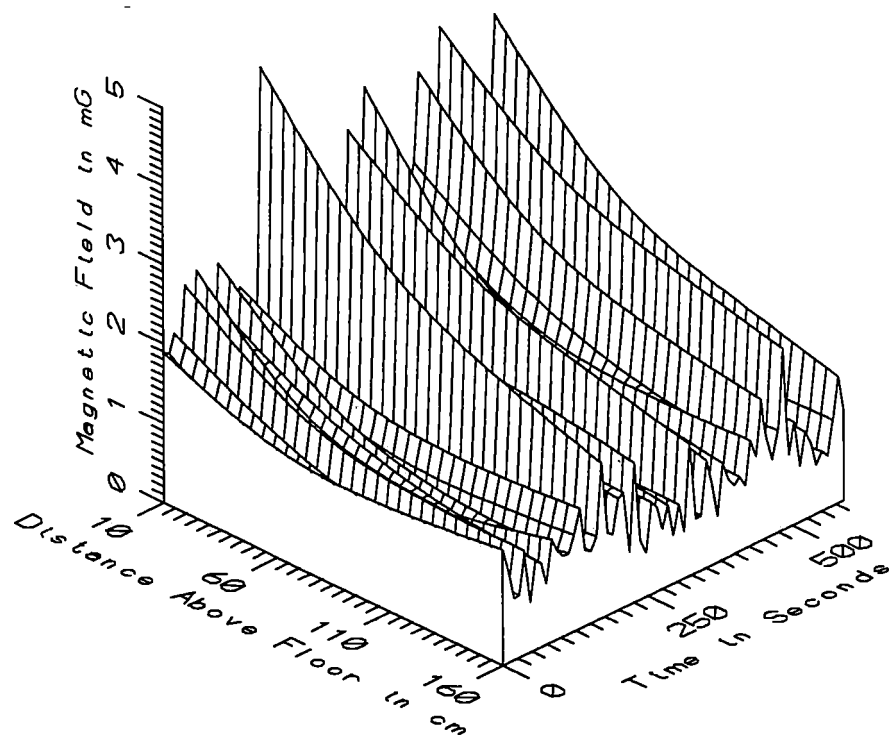

TGV021 - NEAR CORNER OF SEAT 47 IN COACH R5B - HIGH FREQ, 305-2560Hz

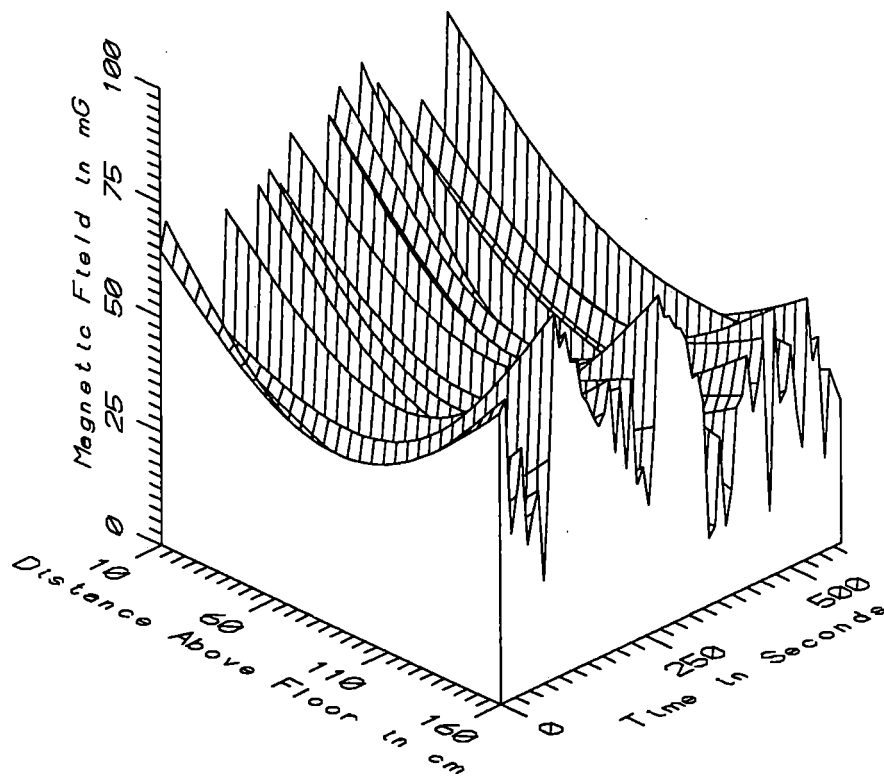

TGV021 - NEAR CORNER OF SEAT 47 IN COACH R5B - ALL FREQ, 5-2560Hz

TGV021 - ALL SAMPLES IN AC SECTION				TOTAL OF 63 SAMPLES		
FREQUENCY BAND	HEIGHT ABOVE FLOOR (cm)	MINIMUM MAGNETIC FIELD (mG)	MAXIMUM MAGNETIC FIELD (mG)	AVERAGE MAGNETIC FIELD (mG)	STANDARD DEVIATION (mG)	COEFFICIENT OF VARIATION (%)
STATIC	10	353.32	488.99	429.22	29.93	6.97
	60	430.32	615.09	537.29	43.70	8.13
	110	551.83	763.46	675.21	49.65	7.35
	160	704.66	962.24	856.88	59.70	6.97
5-45Hz LOW FREQ	10	17.57	83.46	49.34	15.98	32.38
	60	10.06	57.41	31.29	10.47	33.44
	110	7.91	44.53	23.43	8.14	34.73
	160	6.47	34.95	17.94	6.58	36.70
50-60Hz PWR FREQ	10	2.87	48.71	17.81	10.69	60.02
	60	1.22	30.73	14.91	8.00	53.67
	110	1.31	38.23	19.39	10.44	53.85
	160	1.27	78.77	41.61	18.65	44.82
65-300Hz PWR HARM	10	0.74	10.40	4.34	2.05	47.28
	60	0.47	7.42	2.85	1.40	49.07
	110	0.67	5.36	2.30	1.01	43.63
	160	0.97	4.51	2.18	0.76	34.71
305-2560Hz HIGH FREQ	10	0.32	4.92	2.06	0.92	44.82
	60	0.23	3.27	1.35	0.62	45.90
	110	0.35	2.64	1.10	0.46	41.76
	160	0.55	2.27	1.05	0.35	33.45
5-2560Hz ALL FREQ	10	26.08	86.03	53.98	15.26	28.27
	60	17.66	59.93	35.91	9.85	27.42
	110	10.57	48.89	31.91	9.39	29.41
	160	14.57	80.33	46.80	16.08	34.35

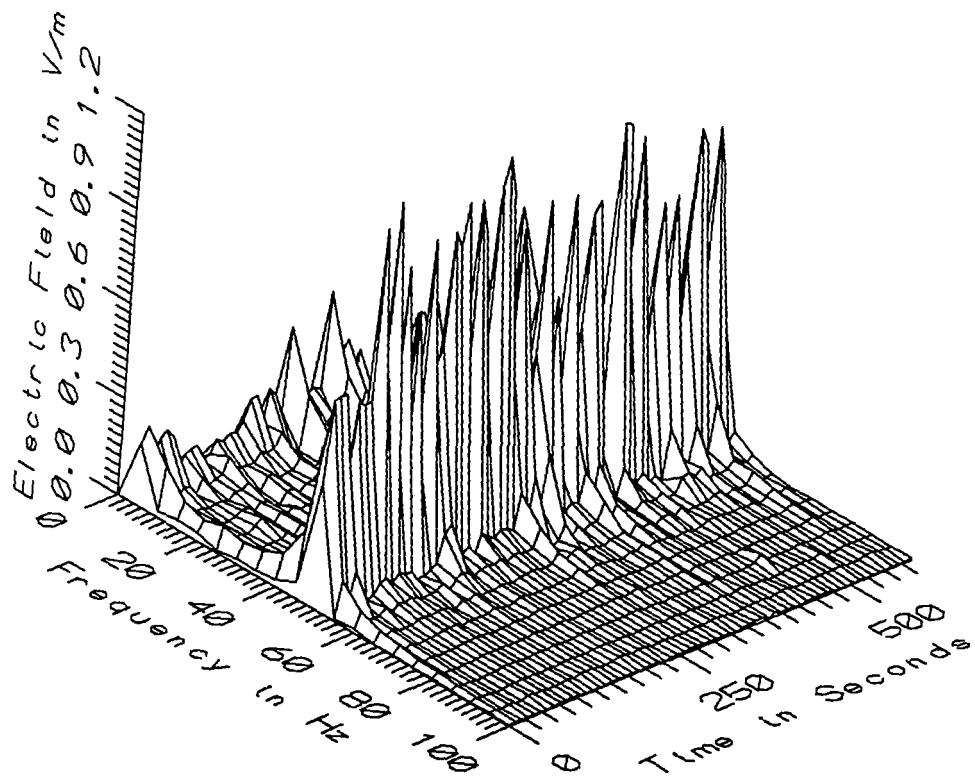

TGV021 - ELECTRIC FIELD IN COACH R5B

APPENDIX W

DATASET TGV022

TRANSVERSE PROFILE FROM SIDE WALL OF SECOND CLASS COACH R5B

Measurement Setup Code:       Staff: 22       Reference: 24  
                                  Drawing: A-1

Vehicle Status:               Coach trip from Vendome station to  
                                  Montparnasse station in Paris

Measurement Date:             September 8, 1992

Measurement Time:            Start:     17:27:51  
                                  End:       17:32:00

Number of Samples:            10

Programmed Sample Interval:  30 sec

Actual Sample Interval:       27.7 sec

Frequency Spectrum Parameters

<u>Probe Type:</u>	<u>Wideband</u>	<u>Static</u>
Maximum Frequency (Hz)	2560	64
Minimum Frequency (Hz)	5	0
Spectral Bandwidth (Hz)	5	1

Missing or Suspect Data:     None

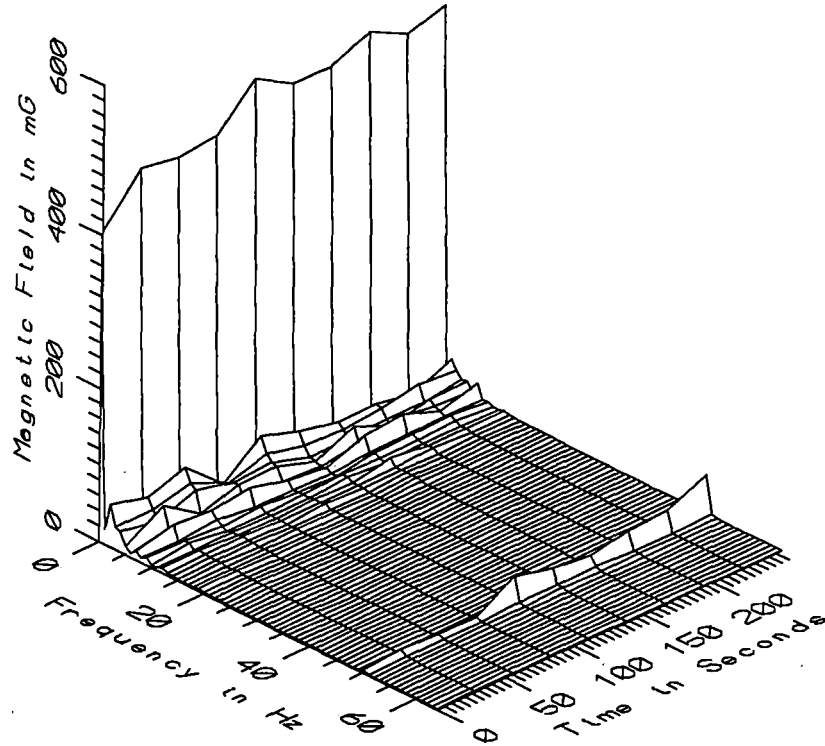

TGV022 - 10cm FROM SIDE WALL ACROSS SEATS 41 & 42 IN COACH R5B

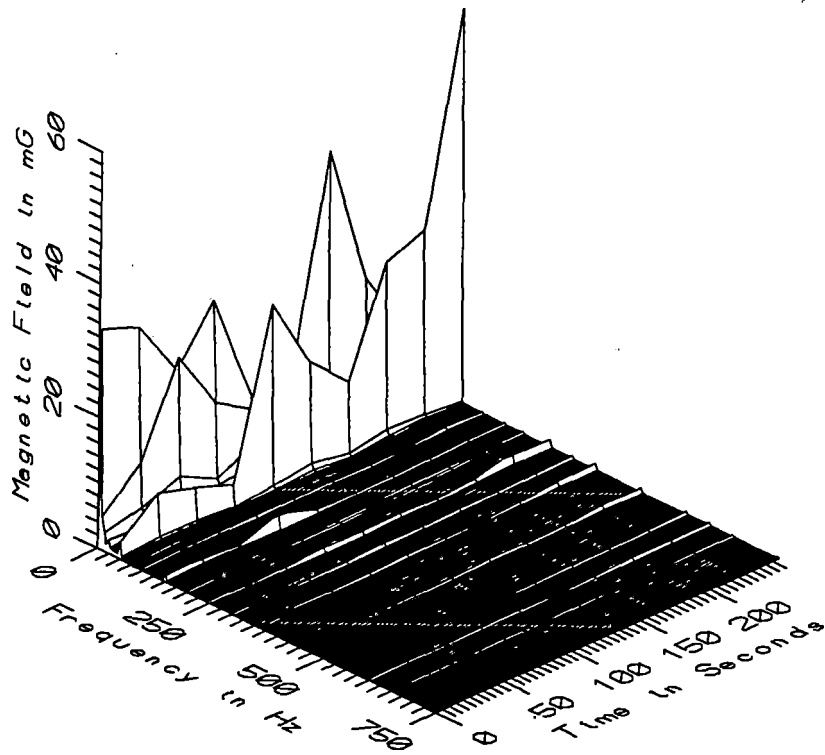

TGV022 - 10cm FROM SIDE WALL ACROSS SEATS 41 & 42 IN COACH R5B

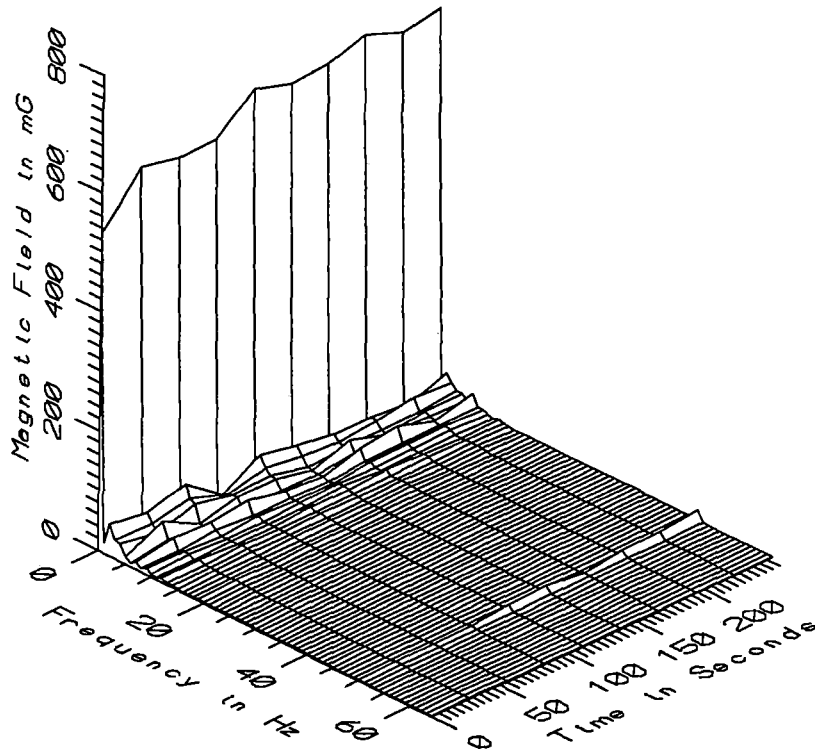

TGV022 - 60cm FROM SIDE WALL ACROSS SEATS 41 & 42 IN COACH R5B

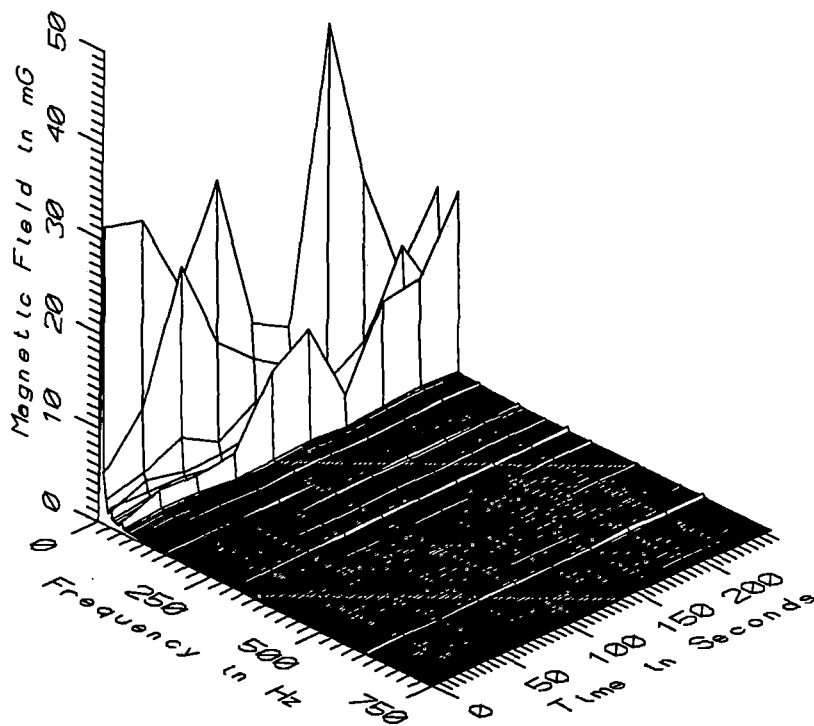

TGV022 - 60cm FROM SIDE WALL ACROSS SEATS 41 & 42 IN COACH R5B



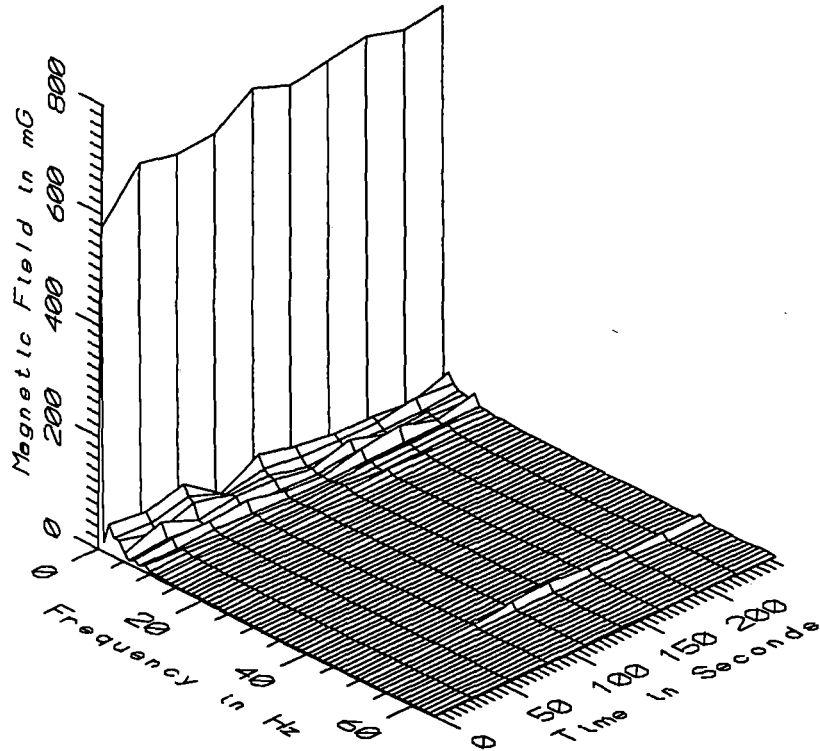

TGV022 - 110cm FROM SIDE WALL ACROSS SEATS 41 & 42 IN COACH R5B

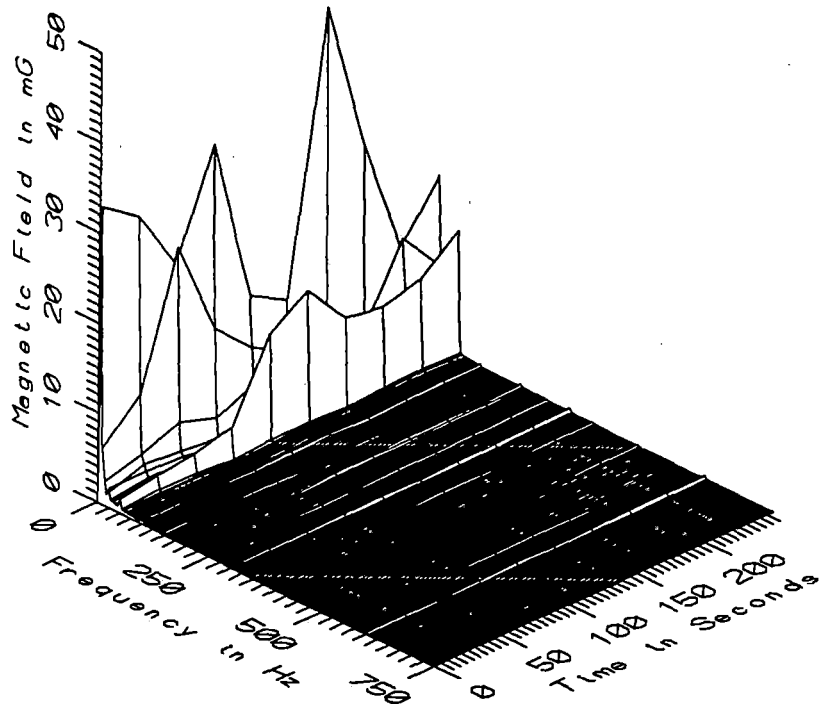

TGV022 - 110cm FROM SIDE WALL ACROSS SEATS 41 & 42 IN COACH R5B

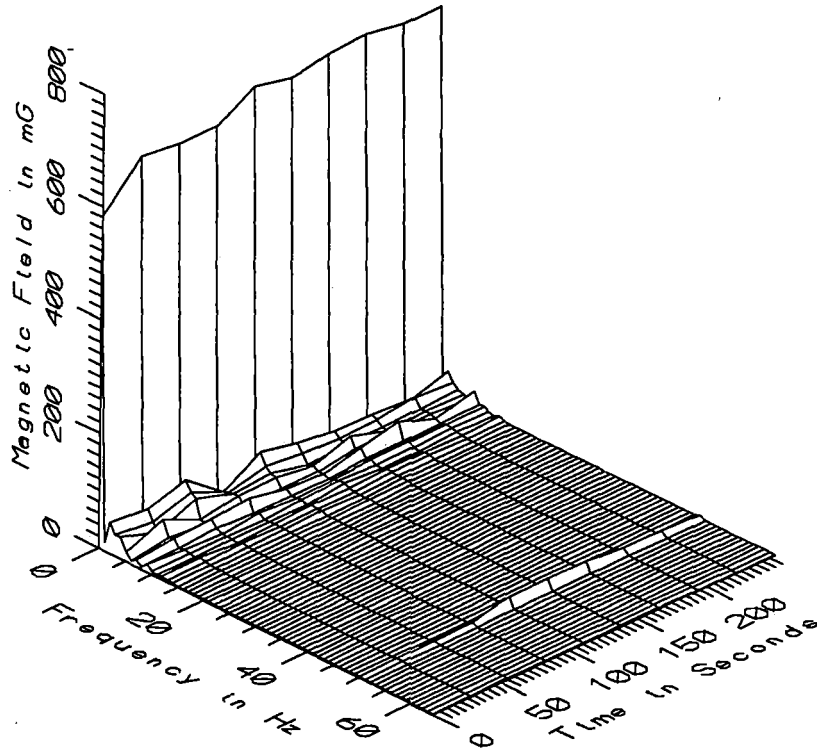

TGV022 - 160cm FROM SIDE WALL ACROSS SEATS 41 & 42 IN COACH R5B

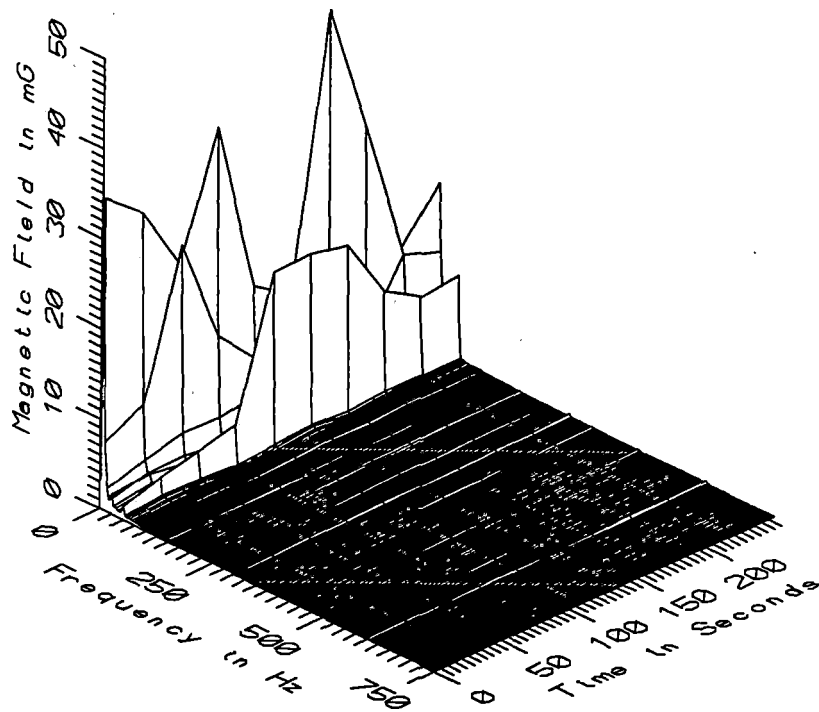

TGV022 - 160cm FROM SIDE WALL ACROSS SEATS 41 & 42 IN COACH R5B

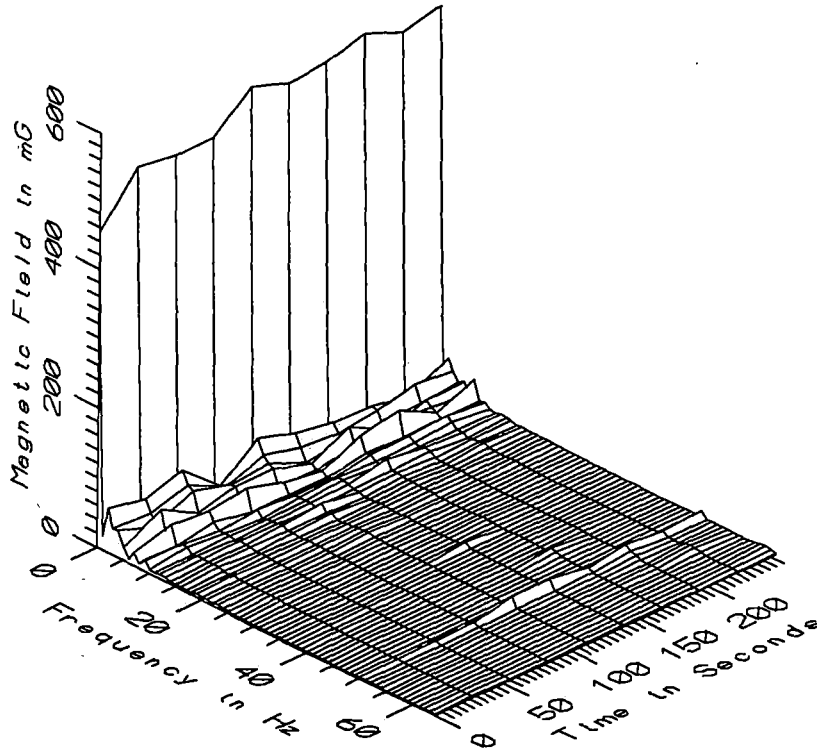

TGV022 - REFERENCE PROBE - ON SEAT 46 IN COACH R5B

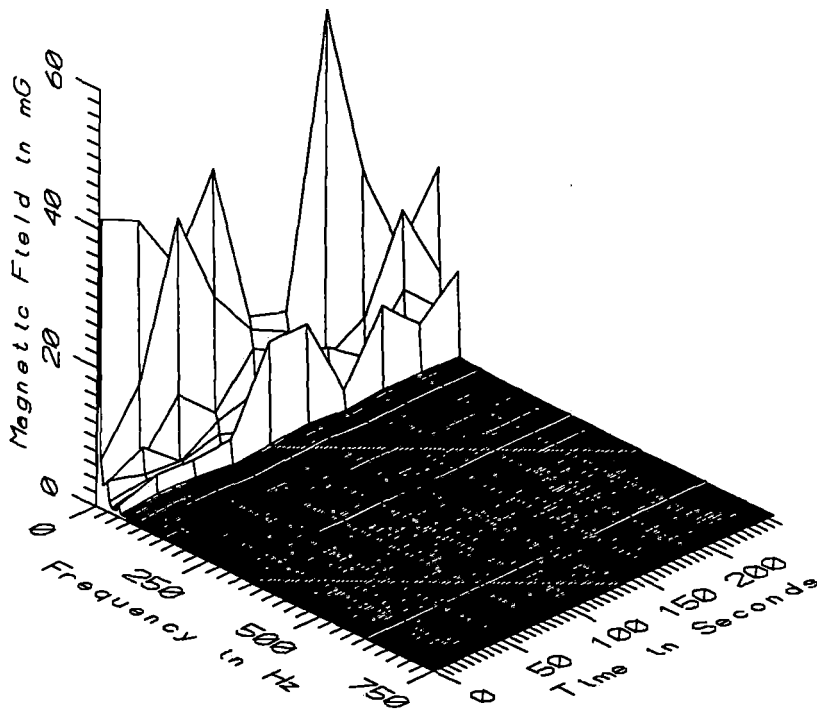

TGV022 - REFERENCE PROBE - ON SEAT 46 IN COACH R5B

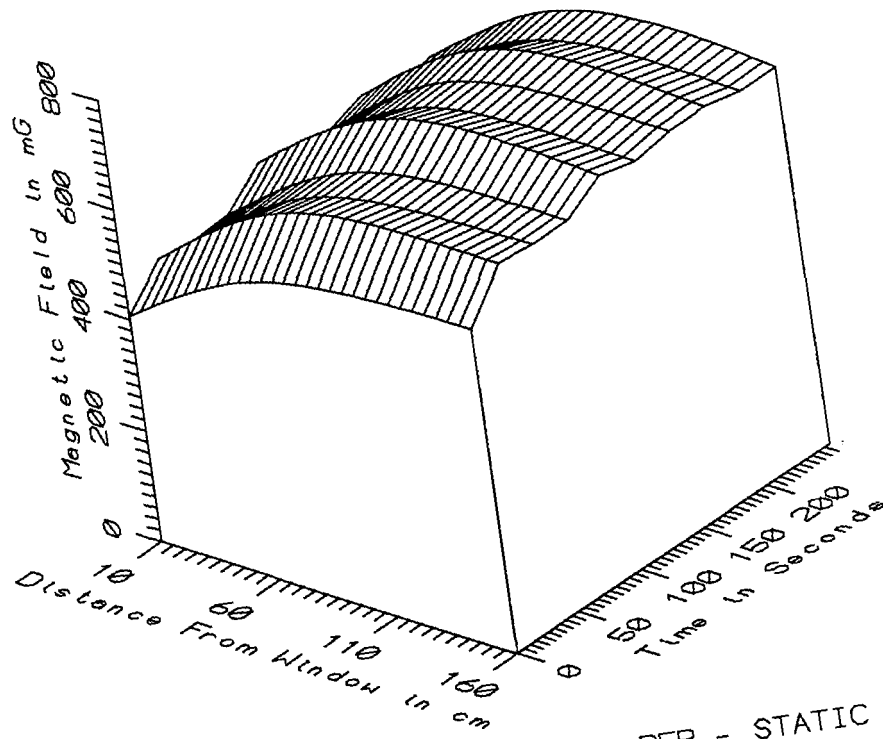

TGV022 - ACROSS SEATS 41 & 42 IN COACH R5B - STATIC

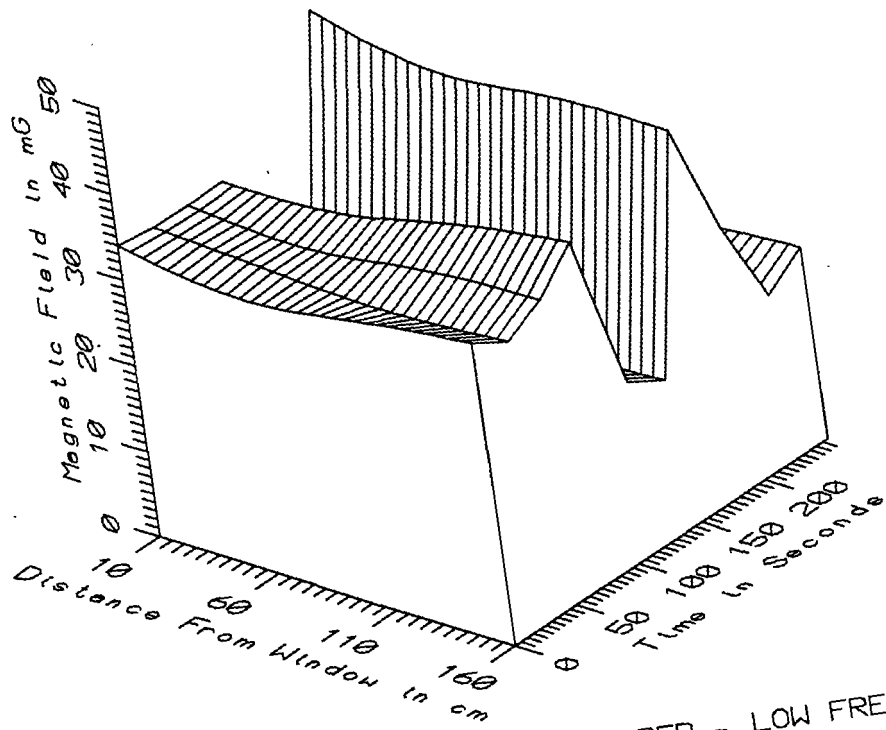

TGV022 - ACROSS SEATS 41 & 42 IN COACH R5B - LOW FREQ, 5-45Hz

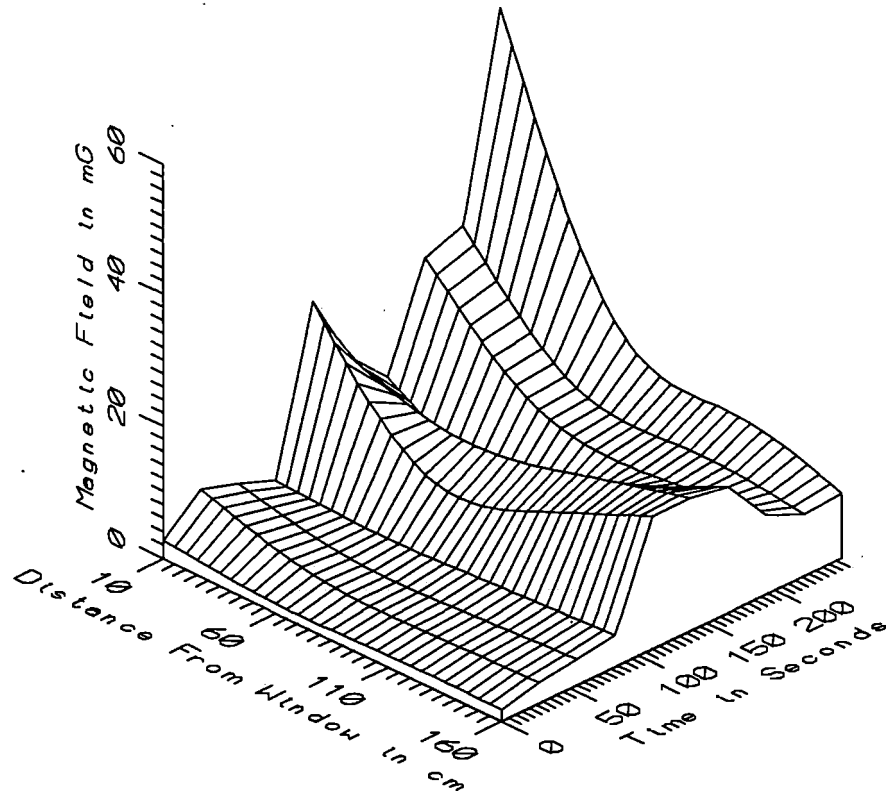

TGV022 - ACROSS SEATS 41 & 42 IN COACH R5B - POWER FREQ, 50-60Hz

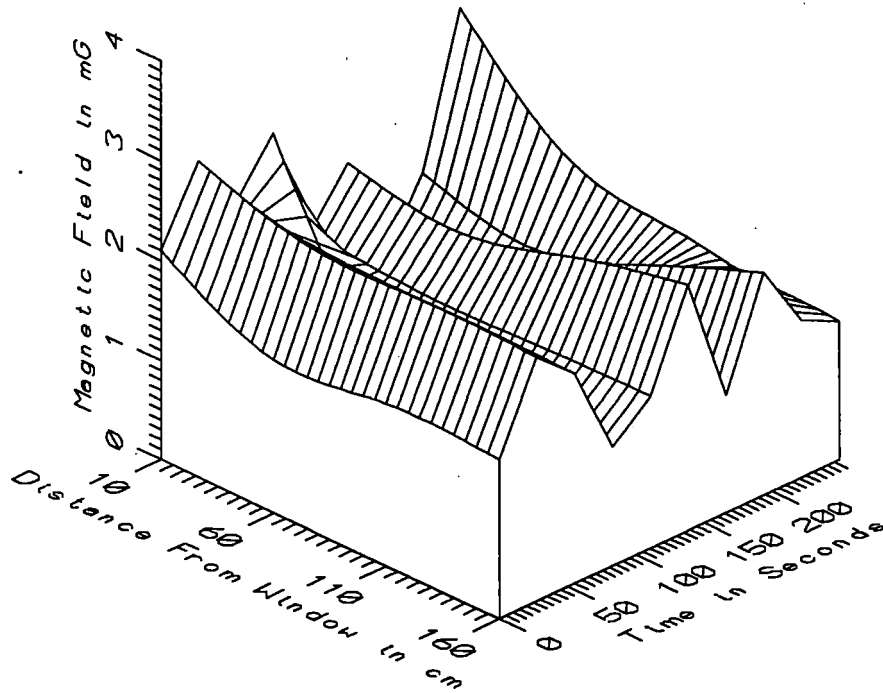

TGV022 - ACROSS SEATS 41 & 42 IN COACH R5B - POWER HARM, 65-300Hz

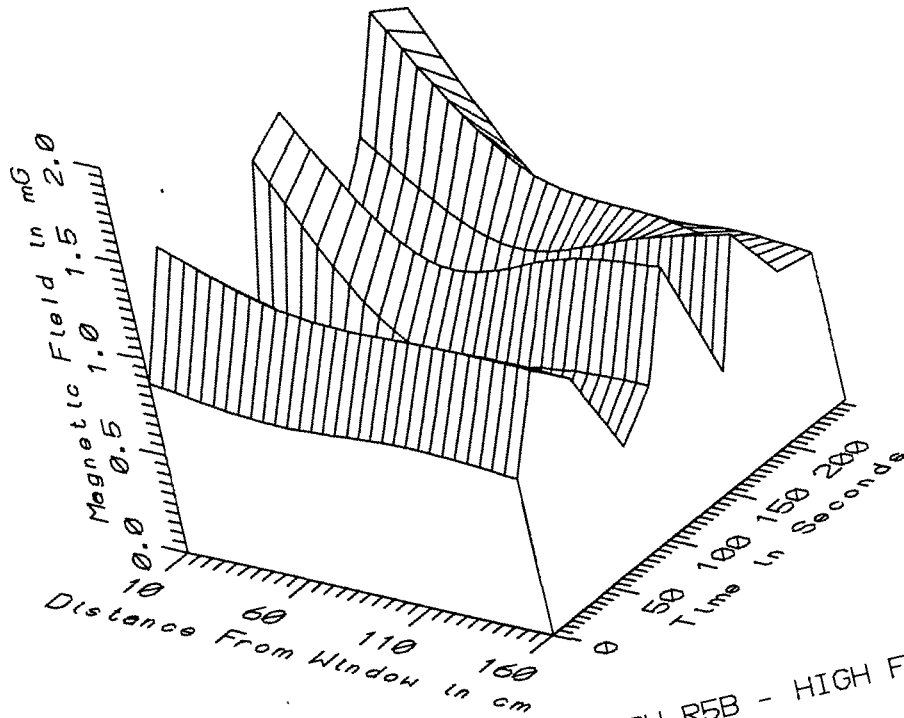

TGV022 - ACROSS SEATS 41 & 42 IN COACH R5B - HIGH FREQ, 305-2560Hz

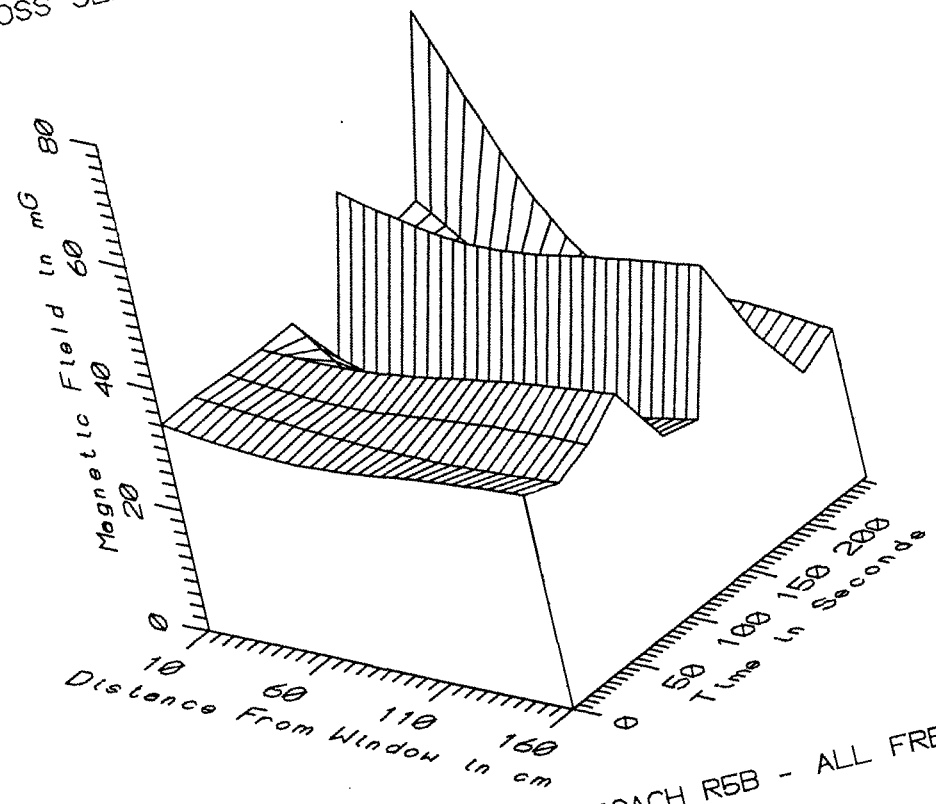

TGV022 - ACROSS SEATS 41 & 42 IN COACH R5B - ALL FREQ, 5-2560Hz

TGV022 - 5th COACH, ALL SAMPLES IN AC SECTION				TOTAL OF 10 SAMPLES		
FREQUENCY BAND	DIST. FROM WINDOW (cm)	MINIMUM MAGNETIC FIELD (mG)	MAXIMUM MAGNETIC FIELD (mG)	AVERAGE MAGNETIC FIELD (mG)	STANDARD DEVIATION (mG)	COEFFICIENT OF VARIATION (%)
STATIC	10	405.89	518.53	480.77	33.35	6.94
	60	532.58	665.44	626.10	39.48	6.31
	110	575.83	707.13	670.63	39.73	5.92
	160	584.61	694.75	667.54	33.12	4.96
5-45Hz LOW FREQ	10	16.00	45.25	28.10	9.10	32.36
	60	15.52	42.43	27.33	8.65	31.65
	110	16.86	43.83	28.69	8.95	31.20
	160	17.91	44.21	29.85	9.23	30.92
50-60Hz PWR FREQ	10	2.72	59.73	19.04	17.55	92.14
	60	1.39	19.50	7.89	6.02	76.25
	110	1.76	15.26	8.32	5.09	61.13
	160	1.71	19.80	10.23	7.11	69.47
65-300Hz PWR HARM	10	0.95	3.08	2.09	0.66	31.44
	60	0.96	2.49	1.63	0.51	31.20
	110	1.11	2.51	1.73	0.47	26.92
	160	1.20	2.49	1.79	0.50	27.89
305-2560Hz HIGH FREQ	10	0.54	1.74	1.27	0.39	30.99
	60	0.43	1.24	0.82	0.26	31.24
	110	0.50	1.23	0.86	0.25	28.55
	160	0.55	1.23	0.88	0.25	28.83
5-2560Hz ALL FREQ	10	23.38	63.55	37.52	10.70	28.53
	60	19.92	42.60	29.50	6.90	23.39
	110	22.87	45.01	30.72	7.32	23.84
	160	21.71	48.05	32.67	7.78	23.81

APPENDIX X

DATASET TGV023  
AXIAL PROFILE FROM CENTER OF SECOND CLASS COACH R5B

Measurement Setup Code:        Staff: 23        Reference: 24  
   Drawing: A-1

Vehicle Status:                Coach trip from Vendome station to  
   Montparnasse station in Paris

Measurement Date:              September 8, 1992

Measurement Time:              Start:        17:33:03  
   End:         17:37:30

Number of Samples:             10

Programmed Sample Interval:   30 sec

Actual Sample Interval:        29.7 sec

Frequency Spectrum Parameters

<u>Probe Type:</u>	<u>Wideband</u>	<u>Static</u>
Maximum Frequency (Hz)	2560	64
Minimum Frequency (Hz)	5	0
Spectral Bandwidth (Hz)	5	1

Missing or Suspect Data:        None



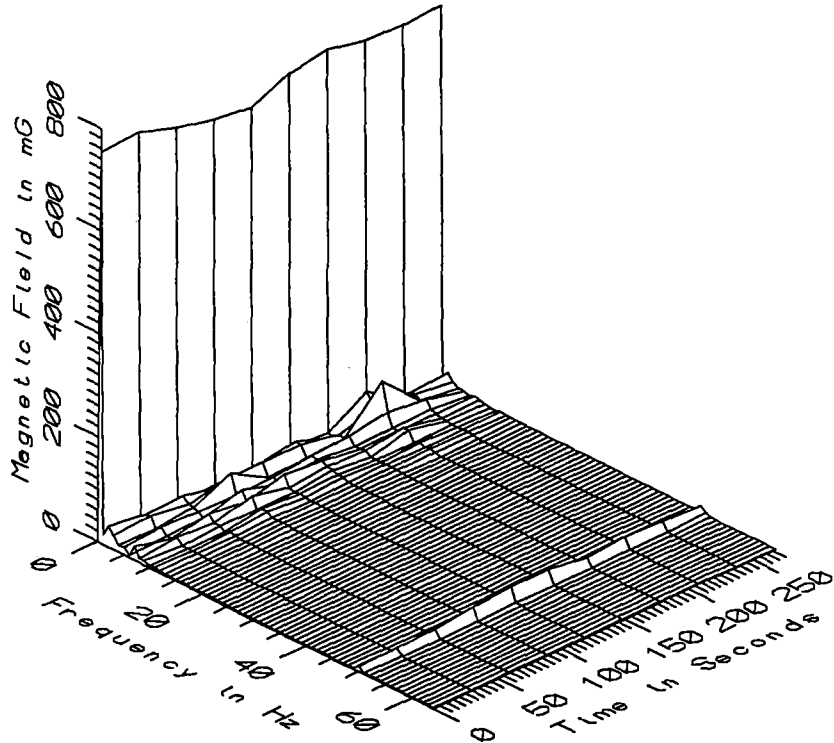

TGV023 - 10cm FROM CORNER OF SEAT 46 ALONG CENTER LINE OF COACH R5B

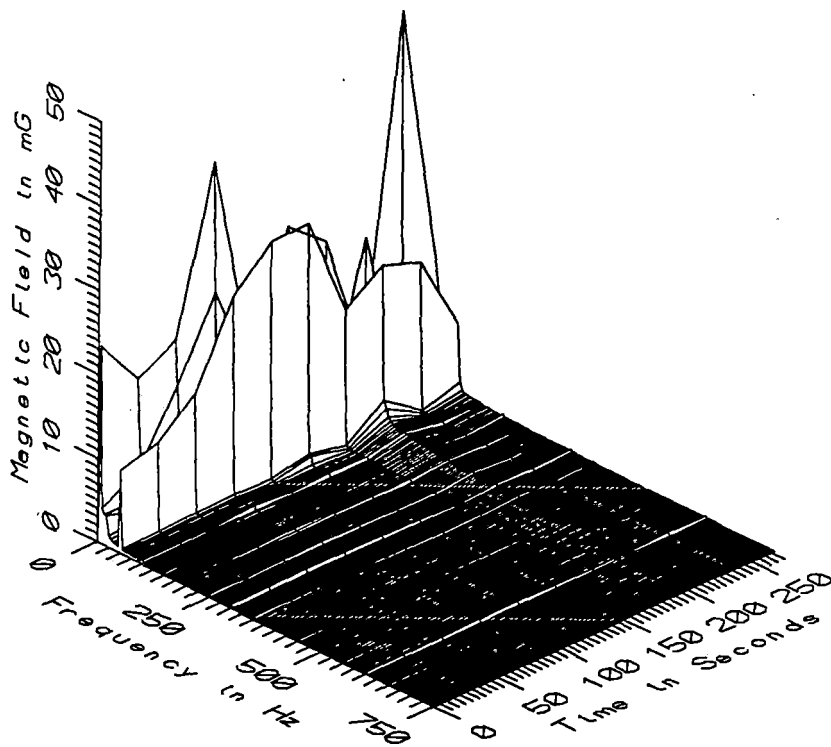

TGV023 - 10cm FROM CORNER OF SEAT 46 ALONG CENTER LINE OF COACH R5B

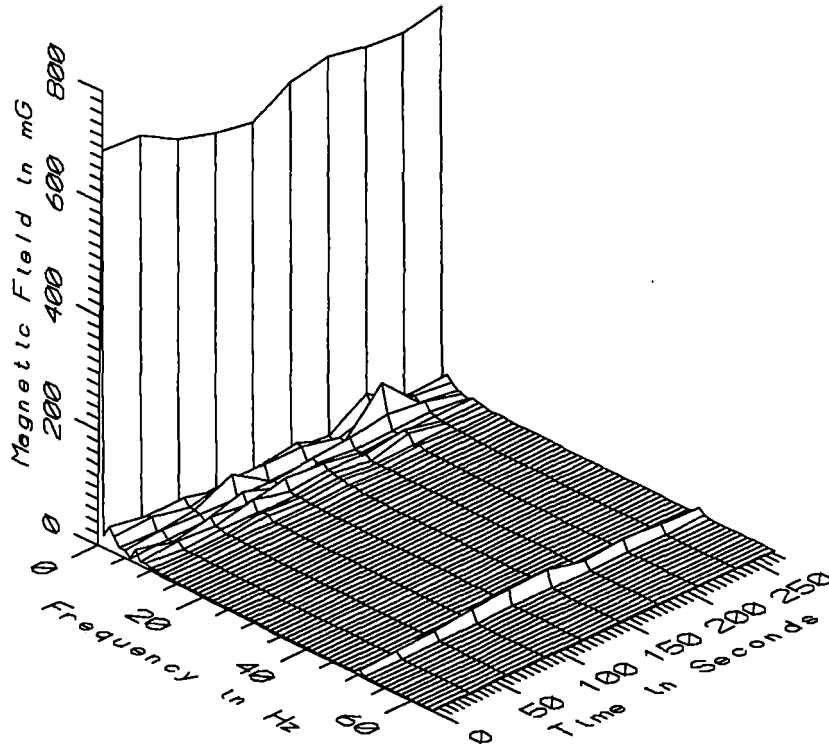

TGV023 - 60cm FROM CORNER OF SEAT 46 ALONG CENTER LINE OF COACH R5B

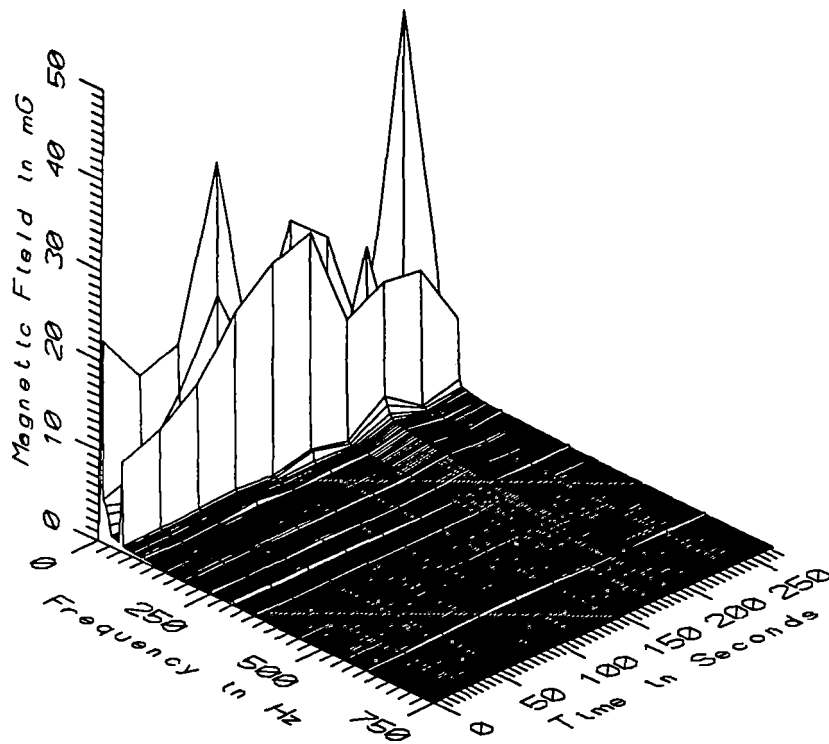

TGV023 - 60cm FROM CORNER OF SEAT 46 ALONG CENTER LINE OF COACH R5B

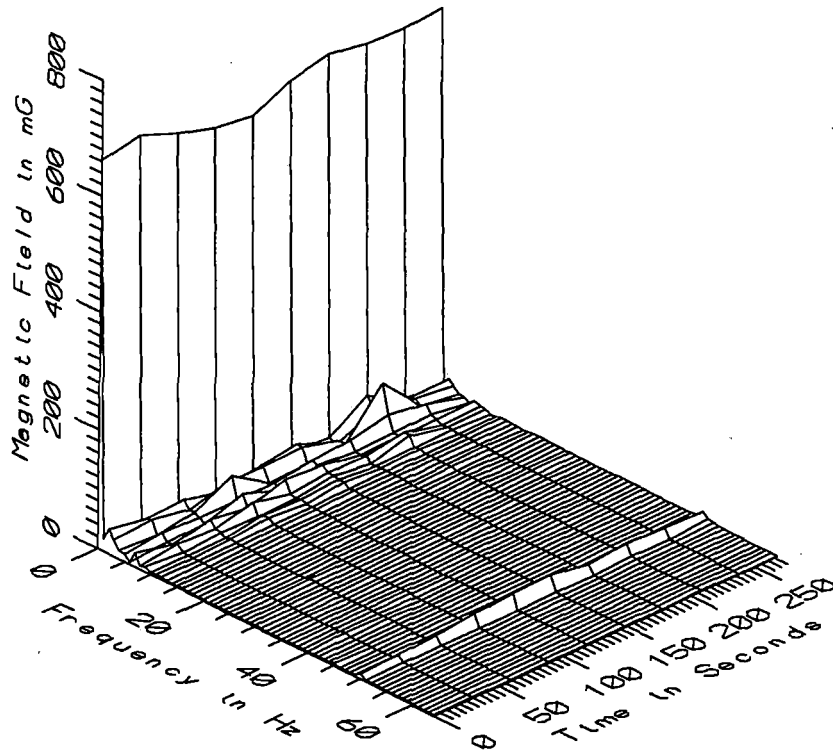

TGV023 - 110cm FROM CORNER OF SEAT 46 ALONG CENTER LINE OF COACH R5B

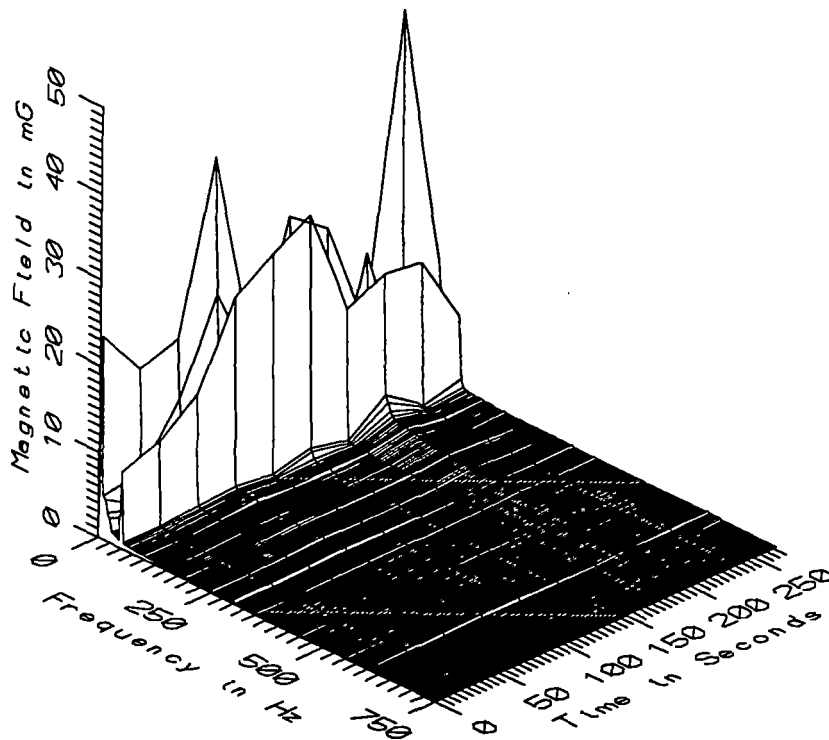

TGV023 - 110cm FROM CORNER OF SEAT 46 ALONG CENTER LINE OF COACH R5B

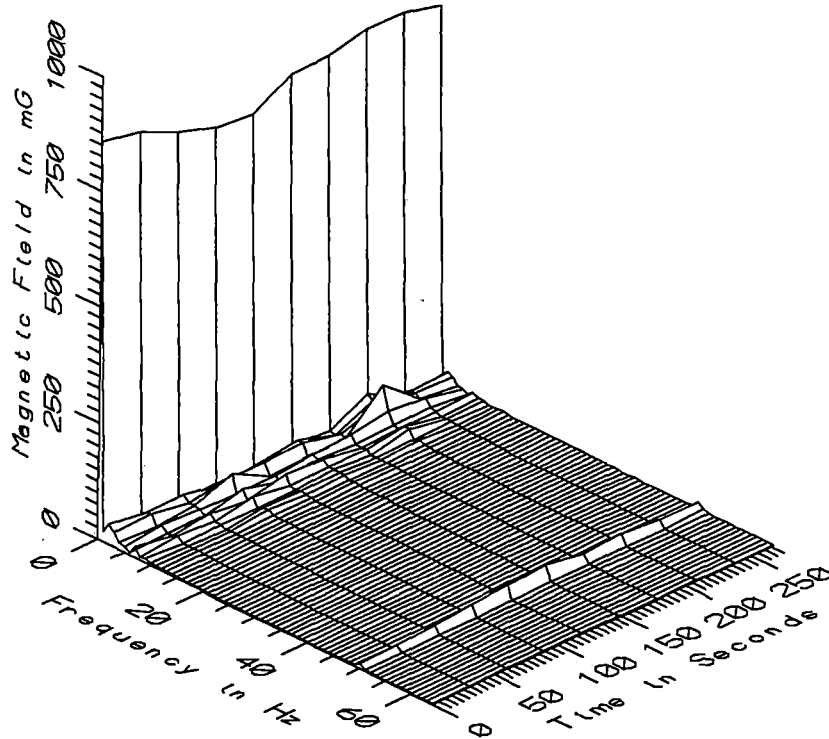

TGV023 - 160cm FROM CORNER OF SEAT 46 ALONG CENTER LINE OF COACH R5B

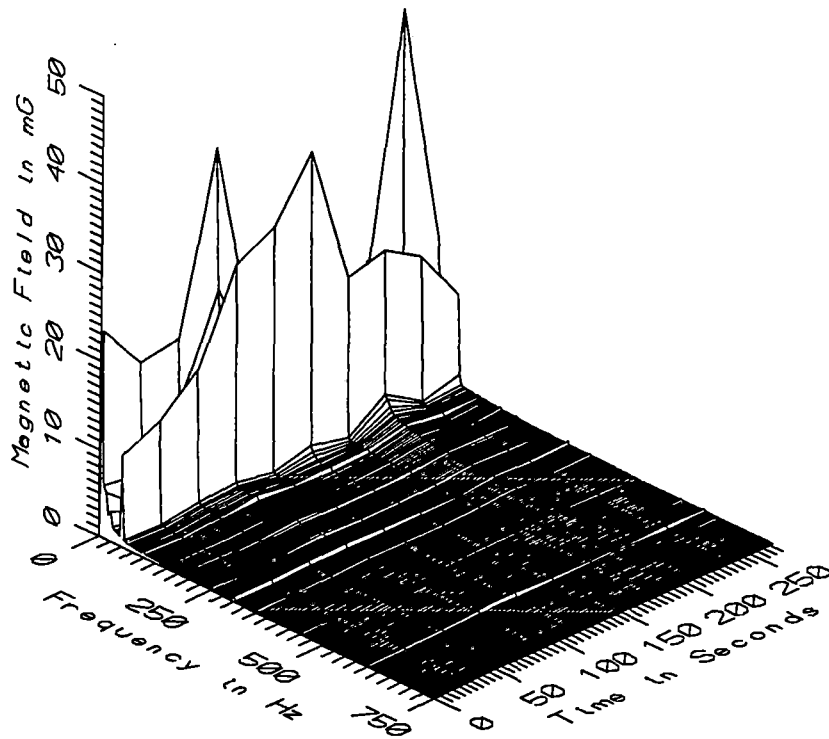

TGV023 - 160cm FROM CORNER OF SEAT 46 ALONG CENTER LINE OF COACH R5B

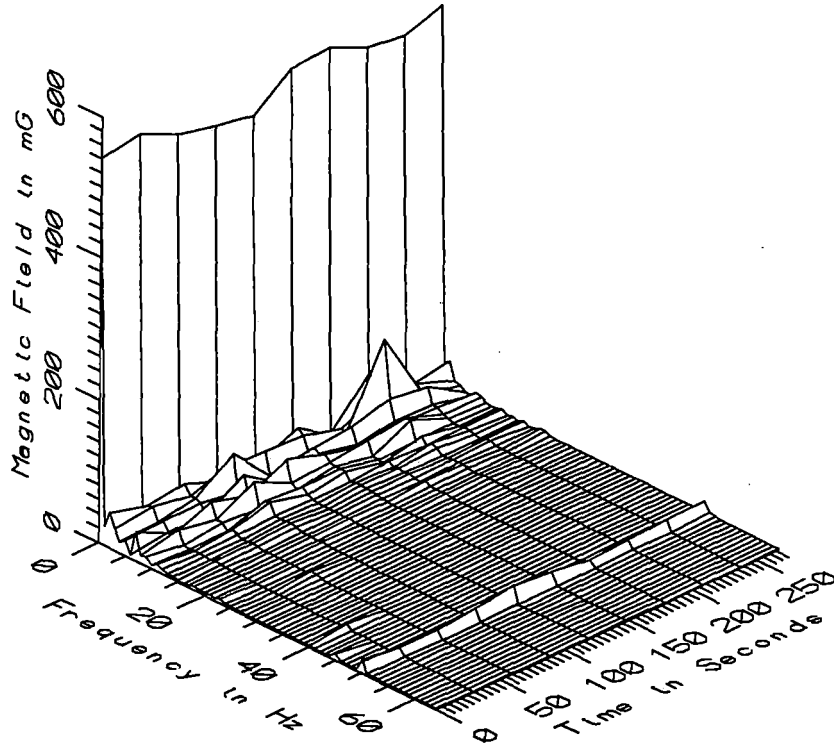

TGV023 - REFERENCE PROBE - ON SEAT 46 IN COACH R5B

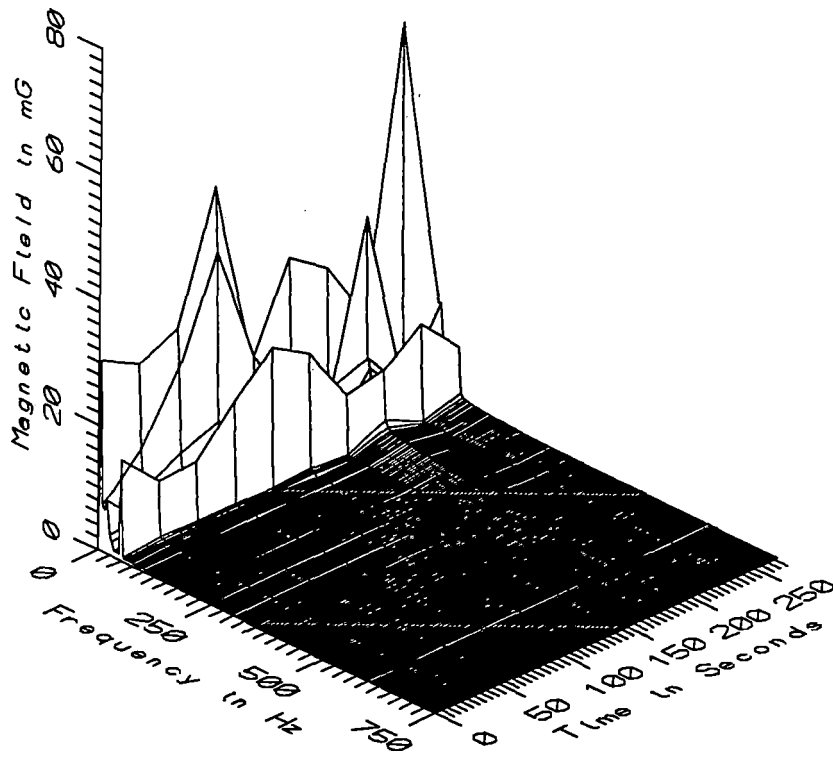

TGV023 - REFERENCE PROBE - ON SEAT 46 IN COACH R5B

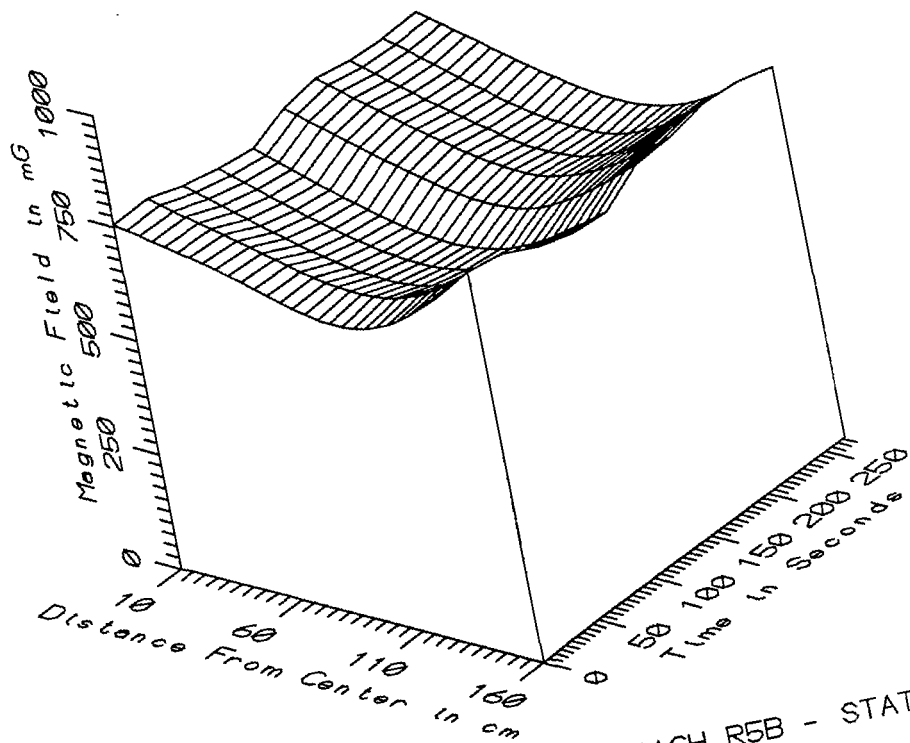

TGV023 - AXIAL PROFILE FROM CENTER OF COACH R5B - STATIC

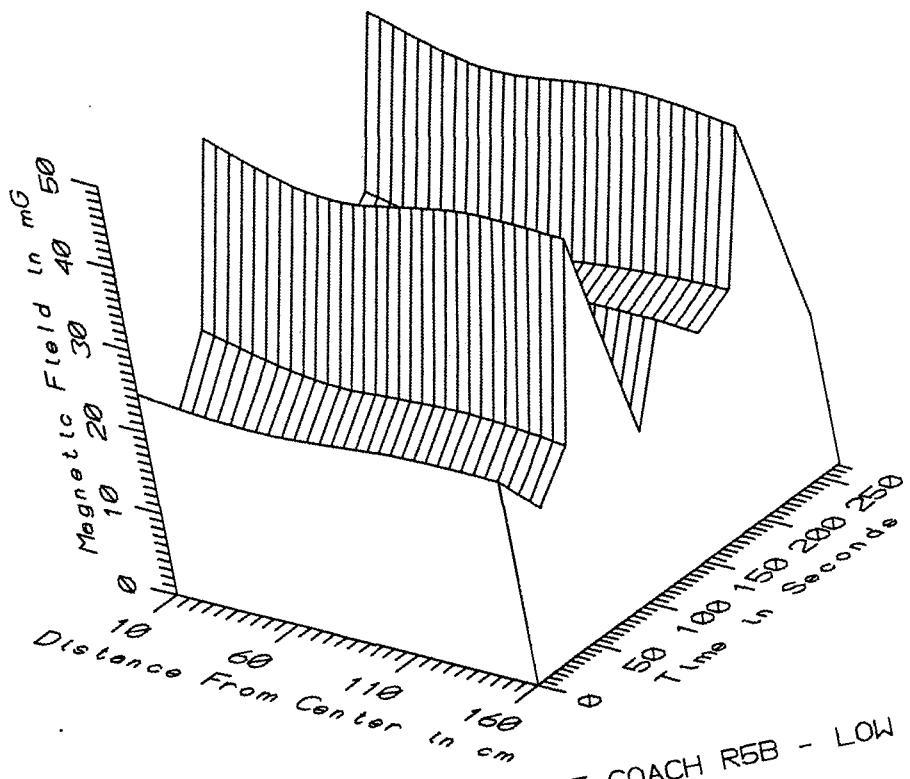

TGV023 - AXIAL PROFILE FROM CENTER OF COACH R5B - LOW FREQ. 5-45Hz

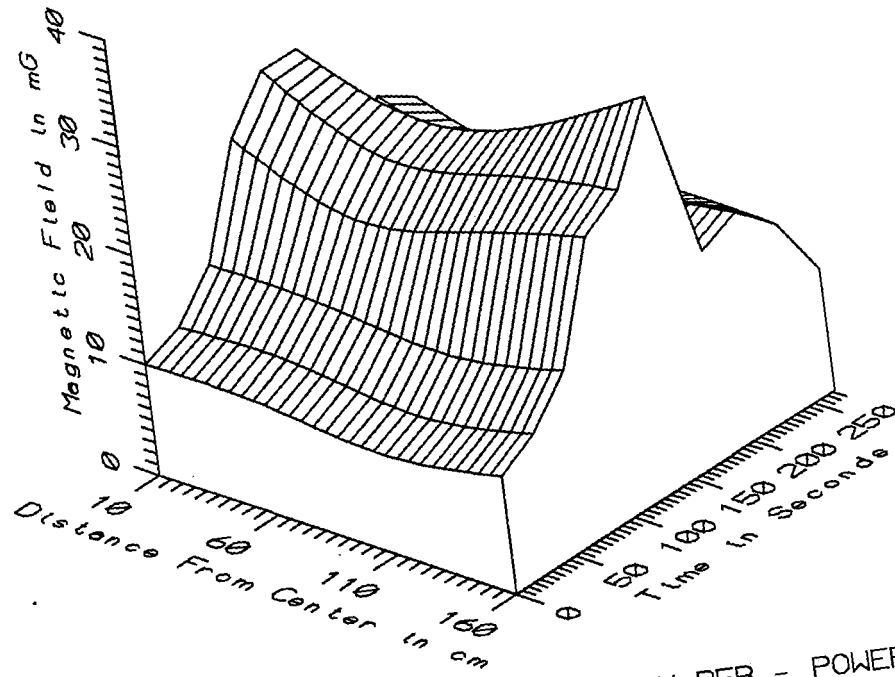

TGV023 - AXIAL PROFILE FROM CENTER OF COACH R5B - POWER FREQ, 50-60Hz

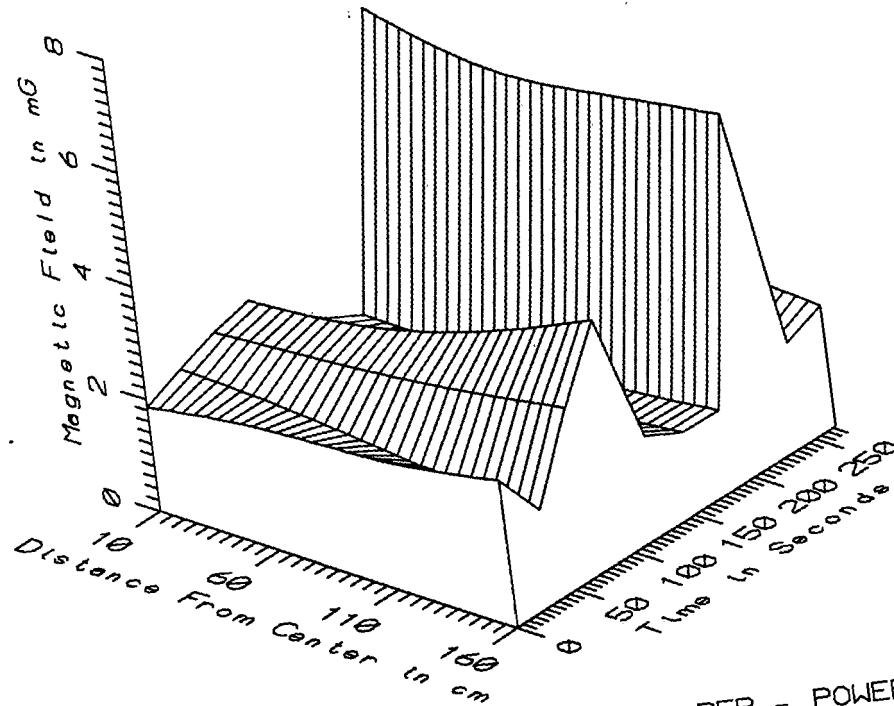

TGV023 - AXIAL PROFILE FROM CENTER OF COACH R5B - POWER HARM, 65-300Hz

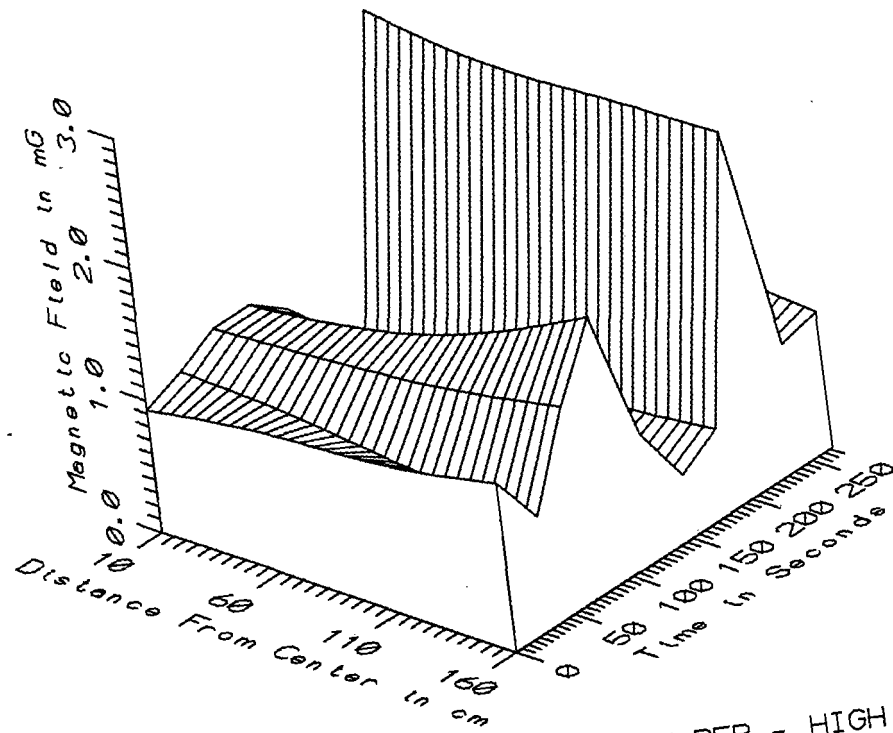

TGV023 - AXIAL PROFILE FROM CENTER OF COACH R5B - HIGH FREQ, 305-2560Hz

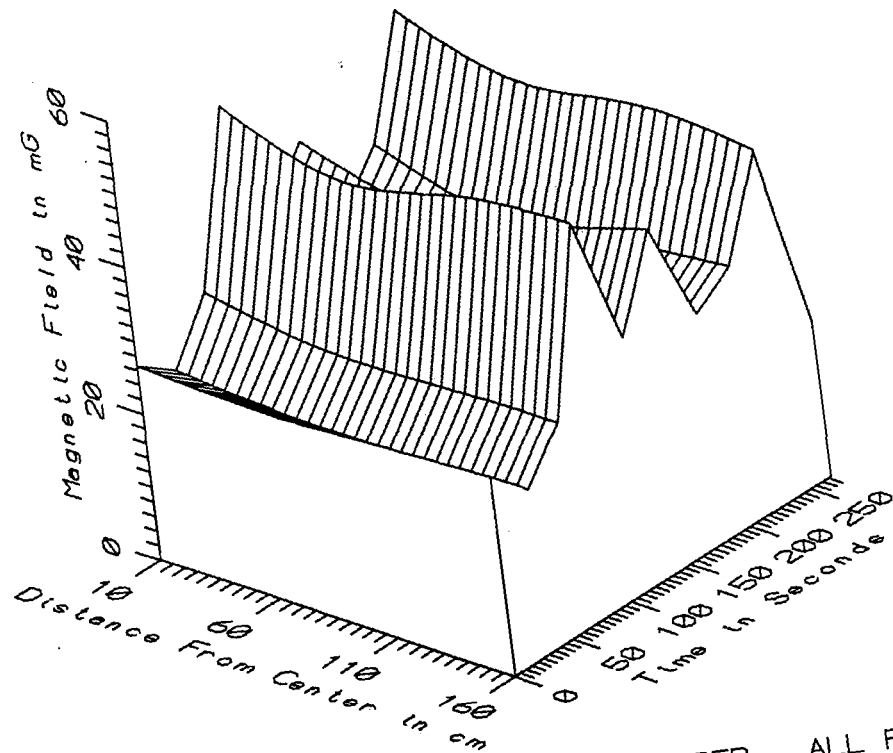

TGV023 - AXIAL PROFILE FROM CENTER OF COACH R5B - ALL FREQ, 5-2560Hz



TGV023 - 5th COACH, ALL SAMPLES IN AC SECTION				TOTAL OF 10 SAMPLES		
FREQUENCY BAND	DIST. FROM CENTER (cm)	MINIMUM MAGNETIC FIELD (mG)	MAXIMUM MAGNETIC FIELD (mG)	AVERAGE MAGNETIC FIELD (mG)	STANDARD DEVIATION (mG)	COEFFICIENT OF VARIATION (%)
STATIC	10	707.23	759.00	737.94	16.55	2.24
	60	623.40	693.62	664.60	22.58	3.40
	110	619.58	675.26	653.27	17.19	2.63
	160	769.03	857.29	818.56	28.90	3.53
5-45Hz LOW FREQ	10	16.21	47.02	28.21	10.67	37.82
	60	14.50	43.61	26.01	9.99	38.41
	110	16.27	45.64	27.51	10.32	37.50
	160	18.11	45.98	27.90	9.90	35.49
50-60Hz PWR FREQ	10	9.12	28.95	18.27	7.32	40.08
	60	8.48	25.76	16.19	5.82	35.93
	110	9.04	28.69	17.20	6.99	40.63
	160	10.68	35.04	19.64	8.06	41.06
65-300Hz PWR HARM	10	1.10	6.12	2.39	1.43	59.76
	60	1.13	5.77	2.33	1.35	57.77
	110	1.27	5.99	2.46	1.41	57.29
	160	1.49	6.33	2.71	1.55	57.07
305-2560Hz HIGH FREQ	10	0.50	2.80	1.15	0.65	56.22
	60	0.49	2.70	1.11	0.63	56.43
	110	0.46	2.73	1.15	0.65	56.16
	160	0.49	2.75	1.25	0.68	54.75
5-2560Hz ALL FREQ	10	18.89	52.71	34.31	11.17	32.55
	60	17.04	47.93	31.24	10.06	32.21
	110	18.80	51.31	33.13	10.78	32.54
	160	21.30	53.16	34.90	10.80	30.95

APPENDIX Y

DATASET TGV024  
CENTER OF SECOND CLASS COACH R5B

Measurement Setup Code:      Staff: 21      Reference: 24  
   Drawing: A-1

Vehicle Status:                      Coach trip from Vendome station to  
   Montparnasse station in Paris

Measurement Date:                      September 8, 1992

Measurement Time:                      Start:      17:38:24  
   End:        17:54:02

Number of Samples:                      32

Programmed Sample Interval:      30 sec

Actual Sample Interval:                30.3 sec

Frequency Spectrum Parameters

<u>Probe Type:</u>	<u>Wideband</u>	<u>Static</u>
Maximum Frequency (Hz)	2560	64
Minimum Frequency (Hz)	5	0
Spectral Bandwidth (Hz)	5	1

Missing or Suspect Data:      None

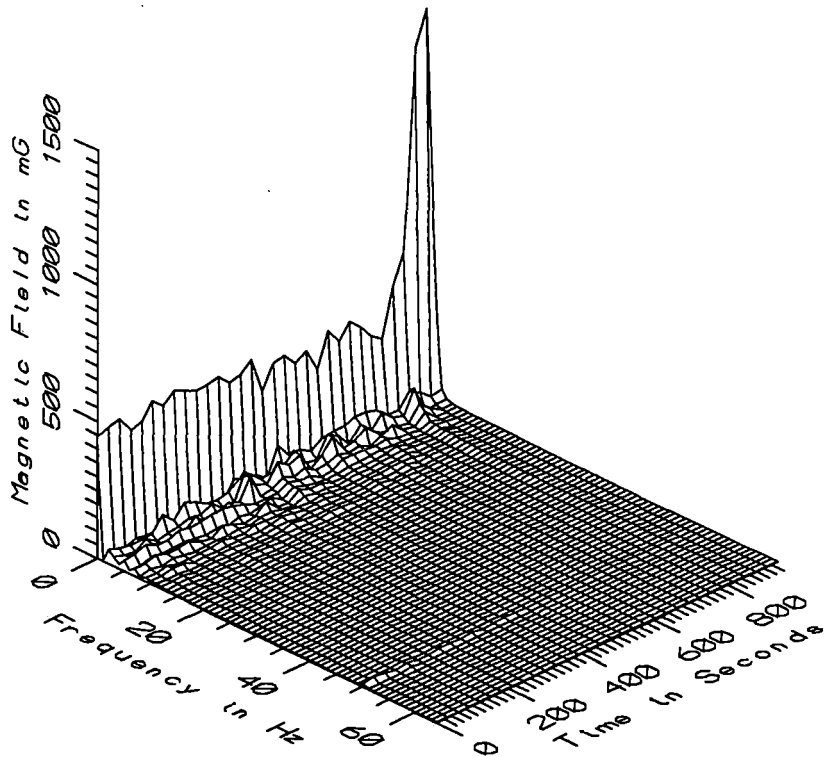

TGV024 - 10cm ABOVE FLOOR NEAR CORNER OF SEAT 47 IN COACH R5B

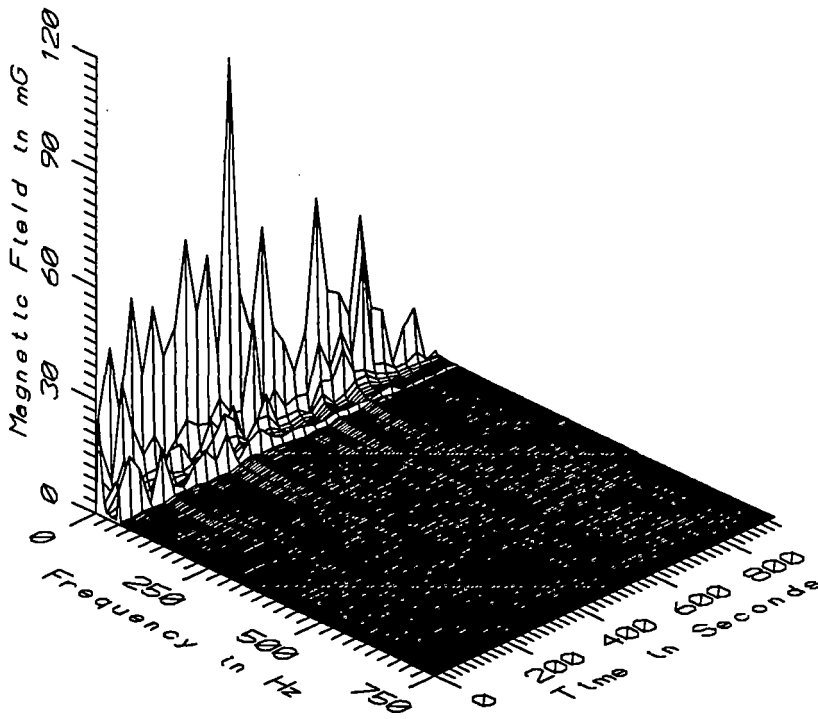

TGV024 - 10cm ABOVE FLOOR NEAR CORNER OF SEAT 47 IN COACH R5B

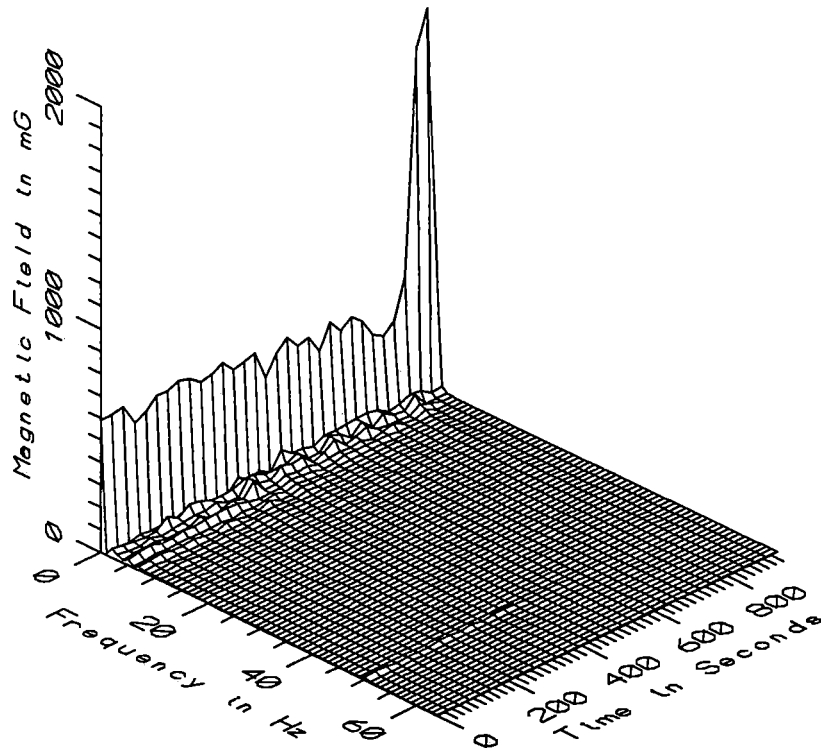

TGV024 - 60cm ABOVE FLOOR NEAR CORNER OF SEAT 47 IN COACH R5B

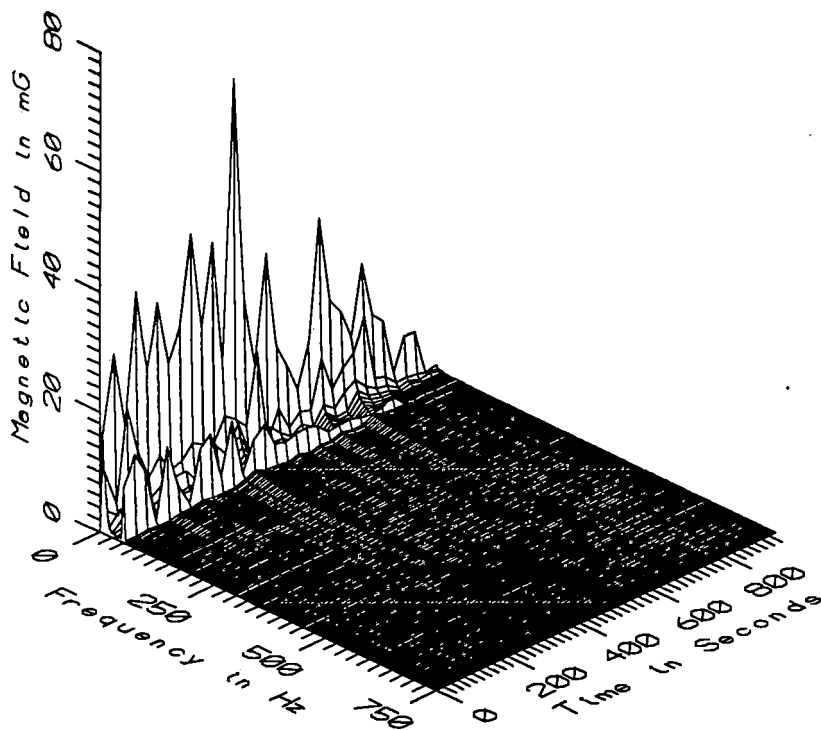

TGV024 - 60cm ABOVE FLOOR NEAR CORNER OF SEAT 47 IN COACH R5B

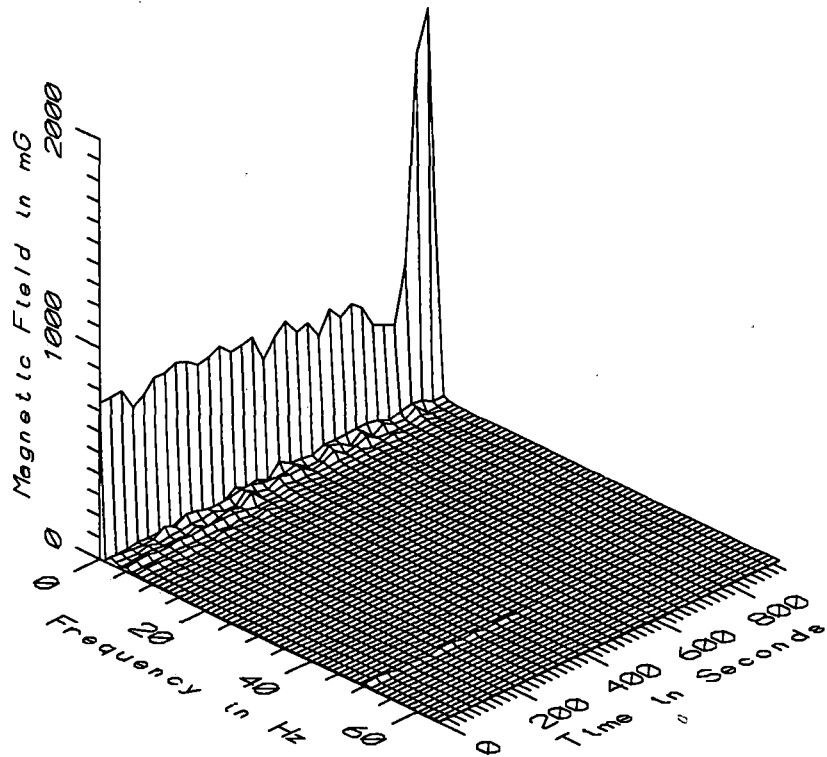

TGV024 - 110cm ABOVE FLOOR NEAR CORNER OF SEAT 47 IN COACH R5B

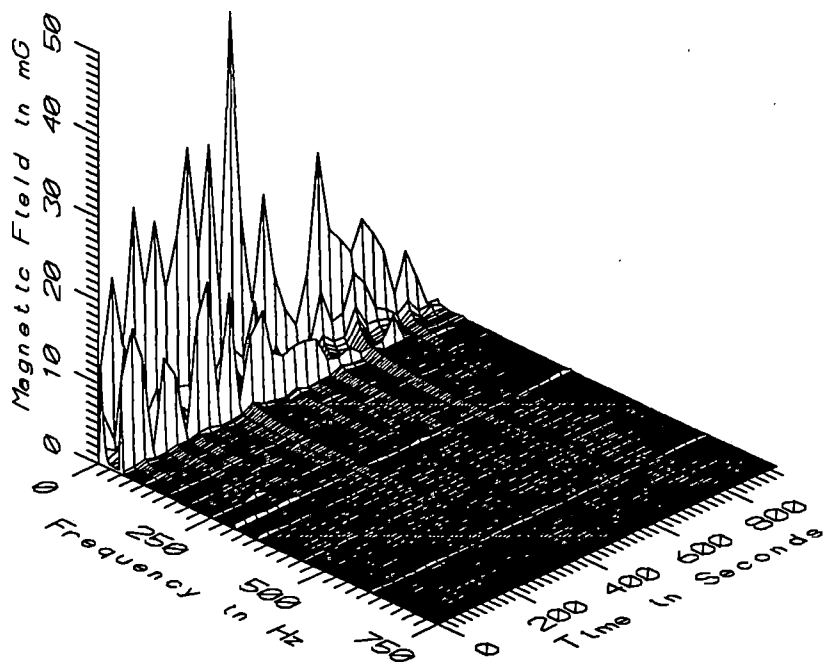

TGV024 - 110cm ABOVE FLOOR NEAR CORNER OF SEAT 47 IN COACH R5B

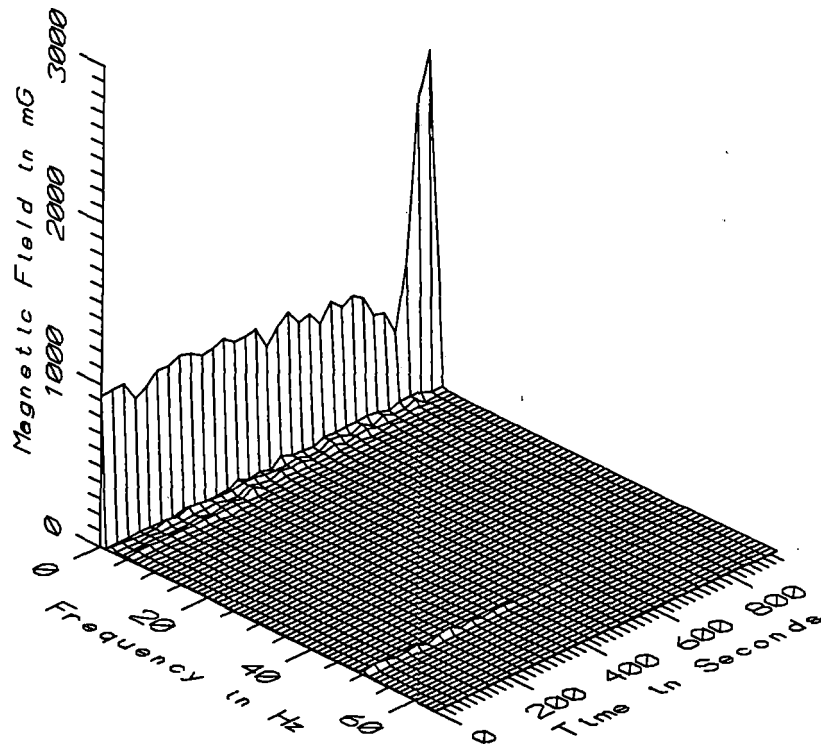

TGV024 - 160cm ABOVE FLOOR NEAR CORNER OF SEAT 47 IN COACH R5B

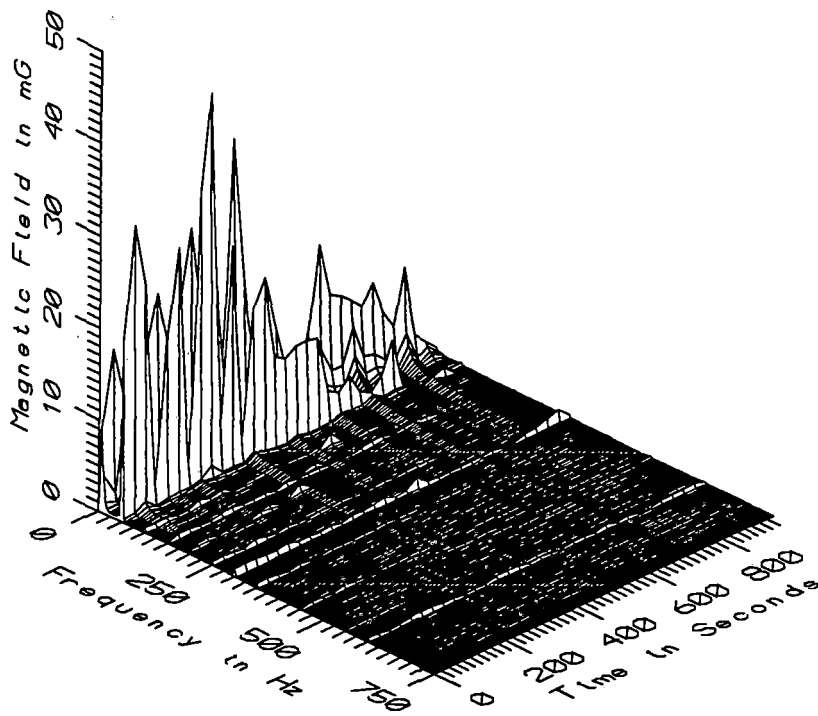

TGV024 - 160cm ABOVE FLOOR NEAR CORNER OF SEAT 47 IN COACH R5B

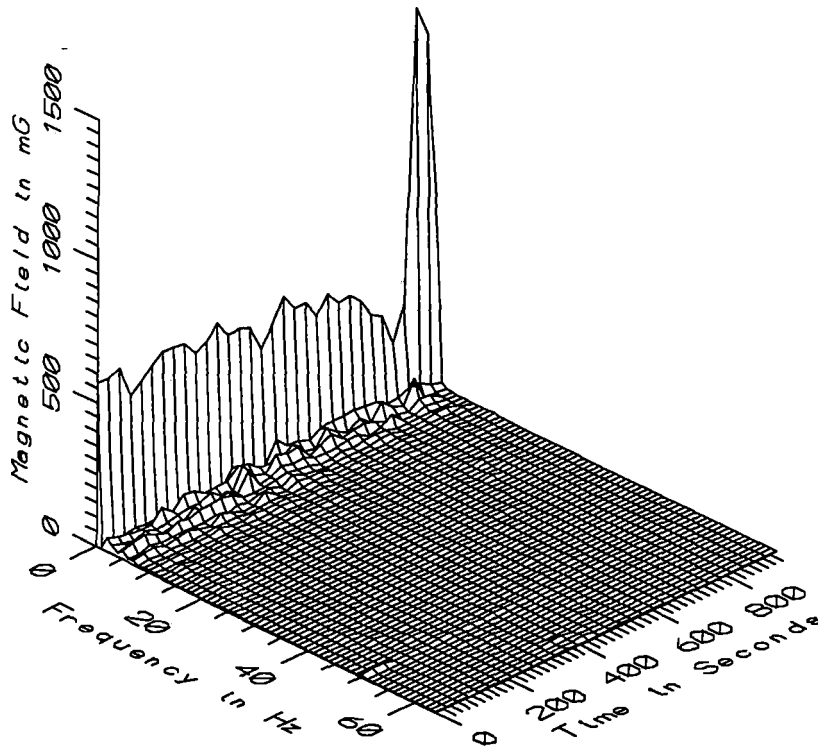

TGV024 - REFERENCE PROBE - ON SEAT 46 IN COACH R5B

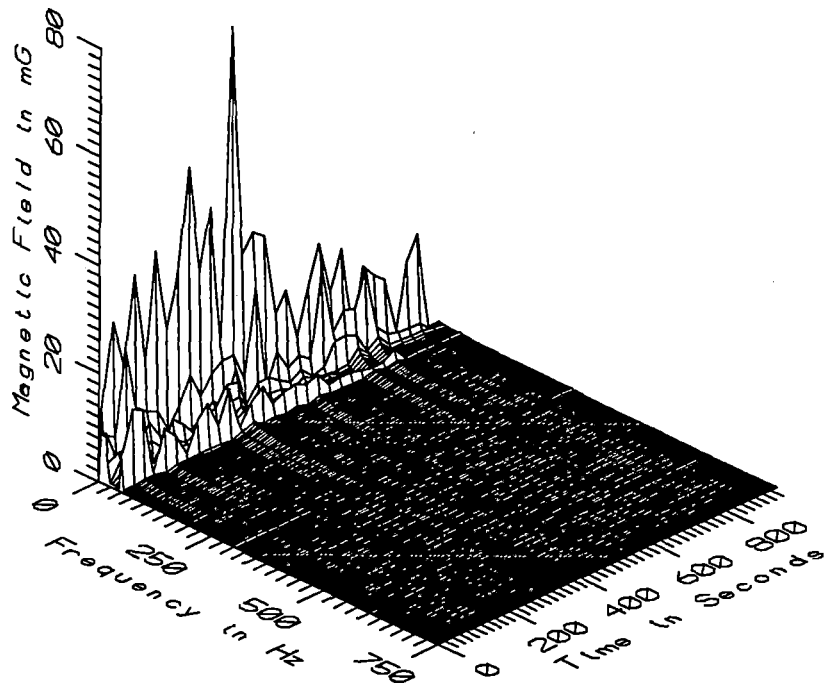

TGV024 - REFERENCE PROBE - ON SEAT 46 IN COACH R5B

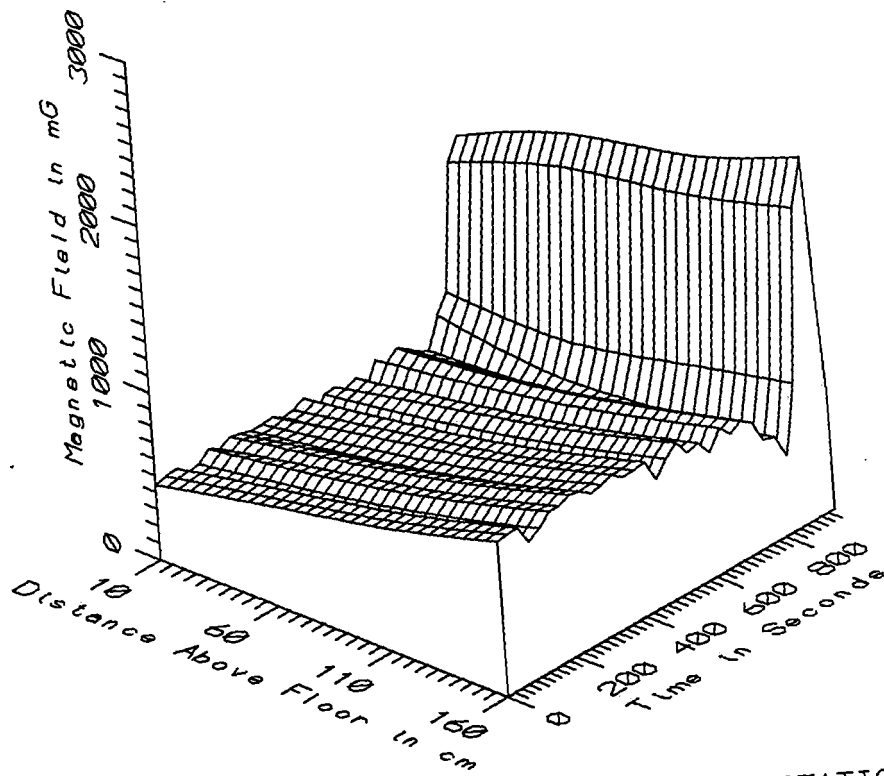

TGV024 - NEAR CORNER OF SEAT 47 IN COACH R5B - STATIC

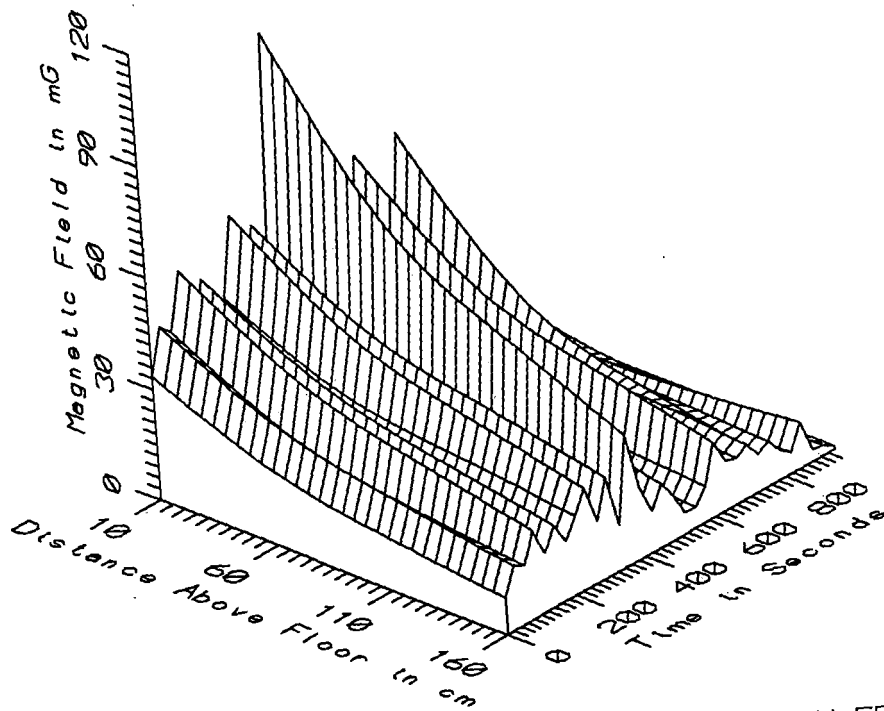

TGV024 - NEAR CORNER OF SEAT 47 IN COACH R5B - LOW FREQ, 5-45Hz



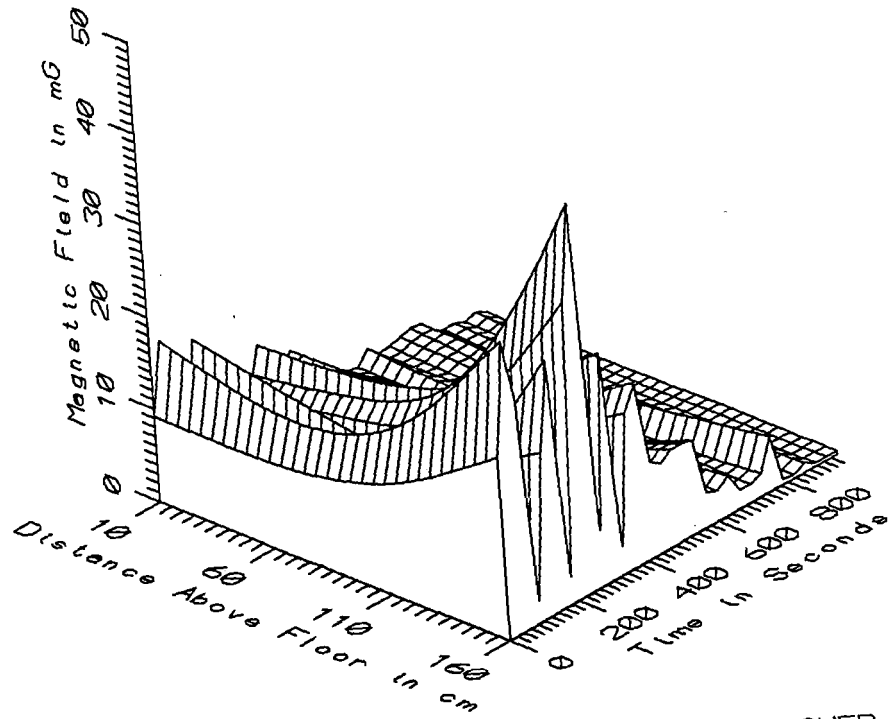

TGV024 - NEAR CORNER OF SEAT 47 IN COACH R5B - POWER FREQ, 50-60Hz

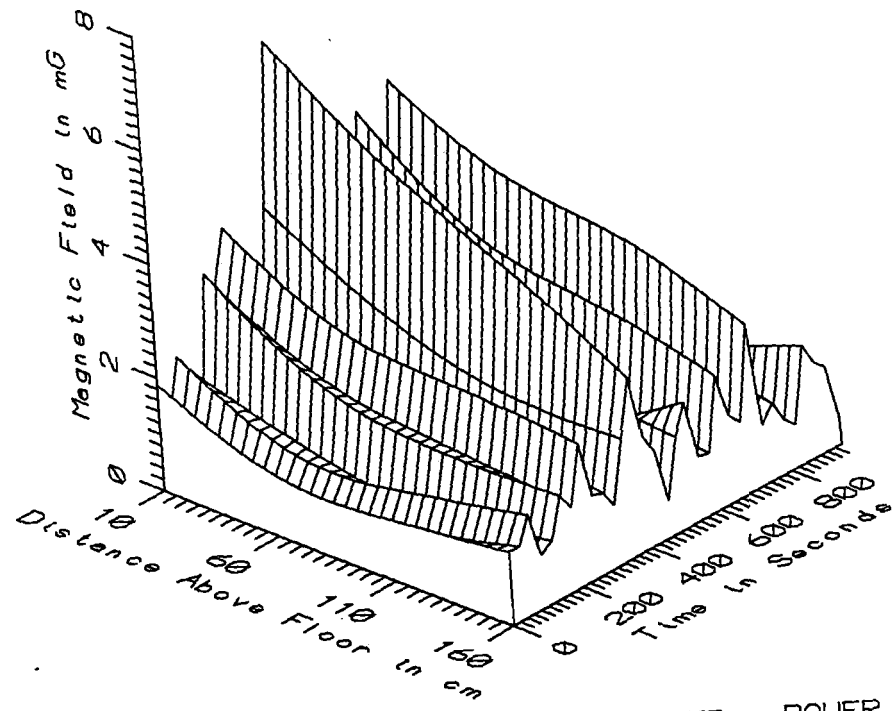

TGV024 - NEAR CORNER OF SEAT 47 IN COACH R5B - POWER HARM, 65-300Hz



TGV024 - ALL SAMPLES		TOTAL OF 32 SAMPLES				
FREQUENCY BAND	HEIGHT ABOVE FLOOR (cm)	MINIMUM MAGNETIC FIELD (mG)	MAXIMUM MAGNETIC FIELD (mG)	AVERAGE MAGNETIC FIELD (mG)	STANDARD DEVIATION (mG)	COEFFICIENT OF VARIATION (%)
STATIC	10	308.08	1468.72	482.36	249.42	51.71
	60	361.34	1755.88	596.63	290.38	48.67
	110	445.09	1898.04	729.01	293.60	40.27
	160	458.16	2153.54	903.98	313.76	34.71
5-45Hz LOW FREQ	10	1.63	106.21	37.18	21.52	57.87
	60	1.24	66.88	23.68	13.71	57.90
	110	1.09	49.10	18.05	10.27	56.88
	160	0.89	34.88	14.11	7.59	53.79
50-60Hz PWR FREQ	10	0.45	16.74	4.77	4.15	86.96
	60	0.28	13.77	4.59	4.02	87.62
	110	0.35	18.59	6.04	5.61	92.80
	160	0.35	42.08	10.83	11.36	104.90
65-300Hz PWR HARM	10	0.40	6.65	2.49	1.51	60.64
	60	0.31	5.25	1.73	1.07	62.06
	110	0.38	4.27	1.55	0.86	55.21
	160	0.46	3.19	1.58	0.63	39.84
305-2560Hz HIGH FREQ	10	0.20	3.24	1.21	0.73	60.66
	60	0.16	2.56	0.84	0.52	61.43
	110	0.22	2.11	0.78	0.41	52.87
	160	0.33	1.65	0.78	0.29	37.57
5-2560Hz ALL FREQ	10	1.86	106.67	37.78	21.63	57.24
	60	1.32	67.50	24.42	13.95	57.14
	110	1.26	50.33	19.53	11.00	56.33
	160	1.11	49.94	19.08	11.89	62.34

TGV024 - AC SECTION ONLY			TOTAL OF 26 SAMPLES			
FREQUENCY BAND	HEIGHT ABOVE FLOOR (cm)	MINIMUM MAGNETIC FIELD (mG)	MAXIMUM MAGNETIC FIELD (mG)	AVERAGE MAGNETIC FIELD (mG)	STANDARD DEVIATION (mG)	COEFFICIENT OF VARIATION (%)
STATIC	10	312.12	478.05	419.95	44.85	10.68
	60	390.50	606.11	535.99	57.37	10.70
	110	496.32	753.69	674.84	65.10	9.65
	160	628.14	953.56	856.56	78.94	9.22
5-45Hz LOW FREQ	10	16.55	106.21	43.60	18.27	41.90
	60	10.40	66.88	27.71	11.76	42.46
	110	7.33	49.10	20.97	8.97	42.77
	160	5.60	34.88	16.11	6.78	42.08
50-60Hz PWR FREQ	10	1.69	16.74	5.67	4.11	72.62
	60	1.19	13.77	5.54	3.89	70.25
	110	1.32	18.59	7.31	5.47	74.84
	160	1.94	42.08	13.21	11.34	85.88
65-300Hz PWR HARM	10	0.82	6.65	2.86	1.42	49.60
	60	0.67	5.25	1.96	1.04	53.31
	110	0.69	4.27	1.71	0.86	50.10
	160	0.69	3.19	1.66	0.62	37.28
305-2560Hz HIGH FREQ	10	0.31	3.24	1.38	0.69	50.13
	60	0.29	2.56	0.95	0.51	53.47
	110	0.34	2.11	0.85	0.42	49.45
	160	0.39	1.65	0.82	0.30	36.48
5-2560Hz ALL FREQ	10	17.01	106.67	44.30	18.24	41.17
	60	11.26	67.50	28.59	11.83	41.36
	110	9.23	50.33	22.76	9.45	41.53
	160	10.24	49.94	22.16	10.93	49.34

TGV024 - DC SECTION ONLY			TOTAL OF 4 SAMPLES			
FREQUENCY BAND	HEIGHT ABOVE FLOOR (cm)	MINIMUM MAGNETIC FIELD (mG)	MAXIMUM MAGNETIC FIELD (mG)	AVERAGE MAGNETIC FIELD (mG)	STANDARD DEVIATION (mG)	COEFFICIENT OF VARIATION (%)
STATIC	10	326.59	1468.72	931.18	560.02	60.14
	60	470.95	1755.88	1097.69	668.18	60.87
	110	557.99	1898.04	1216.60	681.10	55.98
	160	701.07	2153.54	1397.57	725.00	51.88
5-45Hz LOW FREQ	10	1.63	15.97	7.87	7.31	92.83
	60	1.24	8.80	4.95	4.21	85.03
	110	1.09	9.24	4.32	3.72	86.27
	160	0.89	12.32	4.81	5.11	106.19
50-60Hz PWR FREQ	10	0.45	1.14	0.82	0.33	40.27
	60	0.28	0.63	0.41	0.15	36.96
	110	0.35	0.76	0.50	0.18	36.45
	160	0.35	1.05	0.53	0.34	64.62
65-300Hz PWR HARM	10	0.40	0.79	0.61	0.20	33.16
	60	0.31	0.88	0.52	0.25	47.19
	110	0.38	1.29	0.78	0.38	48.68
	160	0.46	2.07	1.41	0.69	48.48
305-2560Hz HIGH FREQ	10	0.20	0.39	0.32	0.09	29.85
	60	0.16	0.43	0.28	0.11	39.83
	110	0.22	0.65	0.44	0.18	40.22
	160	0.33	0.95	0.69	0.26	38.32
5-2560Hz ALL FREQ	10	1.86	16.00	8.03	7.20	89.65
	60	1.32	8.87	5.03	4.18	83.13
	110	1.26	9.38	4.48	3.69	82.46
	160	1.11	12.57	5.17	5.06	98.01

APPENDIX Z

DATASET TGV025  
REVENUE TRAIN LOCOMOTIVE, AGAINST ENGINEER'S CHAIR

Measurement Setup Code:      Staff: 25      Reference: 26  
   Drawing: A-2

Vehicle Status:                      Locomotive trip from Montparnasse  
   station in Paris to Vendome station

Measurement Date:                      September 9, 1992

Measurement Time:                      Start:      07:44:50  
   End:        08:00:33

Number of Samples:                      88

Programmed Sample Interval:      10 sec

Actual Sample Interval:                10.8 sec

Frequency Spectrum Parameters

<u>Probe Type:</u>	<u>Wideband</u>	<u>Static</u>
Maximum Frequency (Hz)	2560	64
Minimum Frequency (Hz)	5	0
Spectral Bandwidth (Hz)	5	1

Missing or Suspect Data:              60 cm sensor malfunctioning early  
   in the record

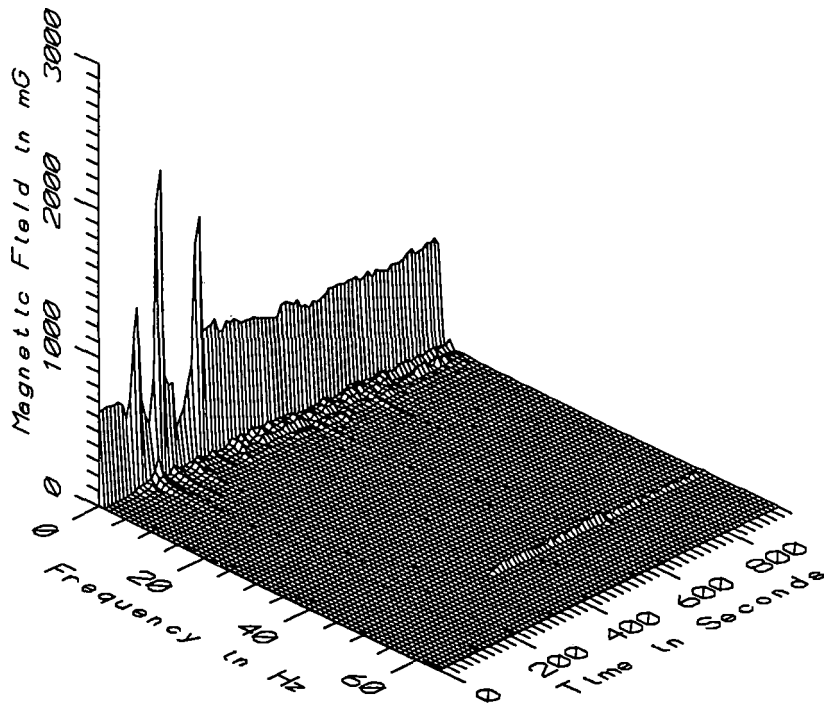

TGV025 - 10cm ABOVE FLOOR AGAINST ENGINEER'S CHAIR, REVENUE TRAIN

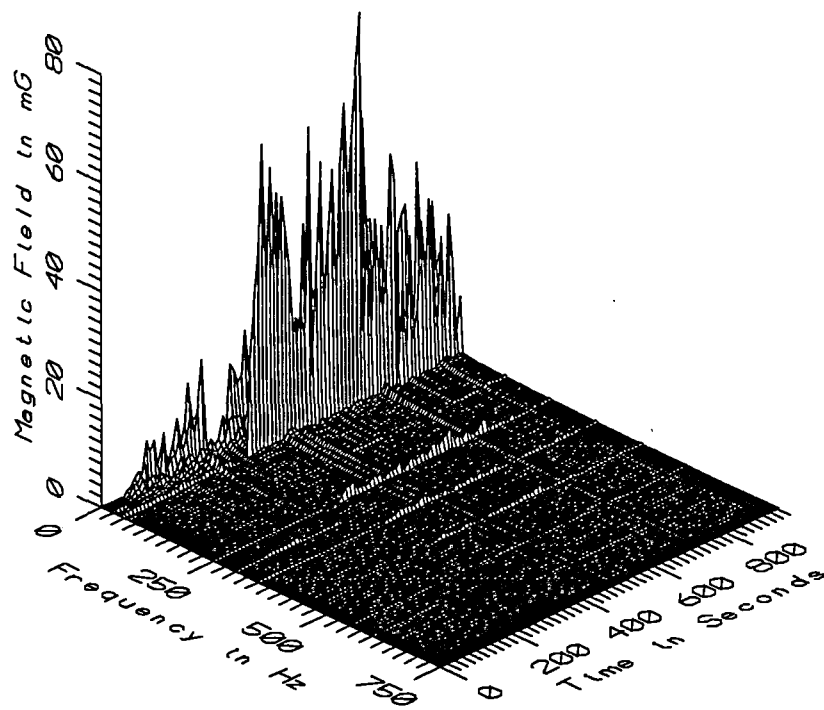

TGV025 - 10cm ABOVE FLOOR AGAINST ENGINEER'S CHAIR, REVENUE TRAIN





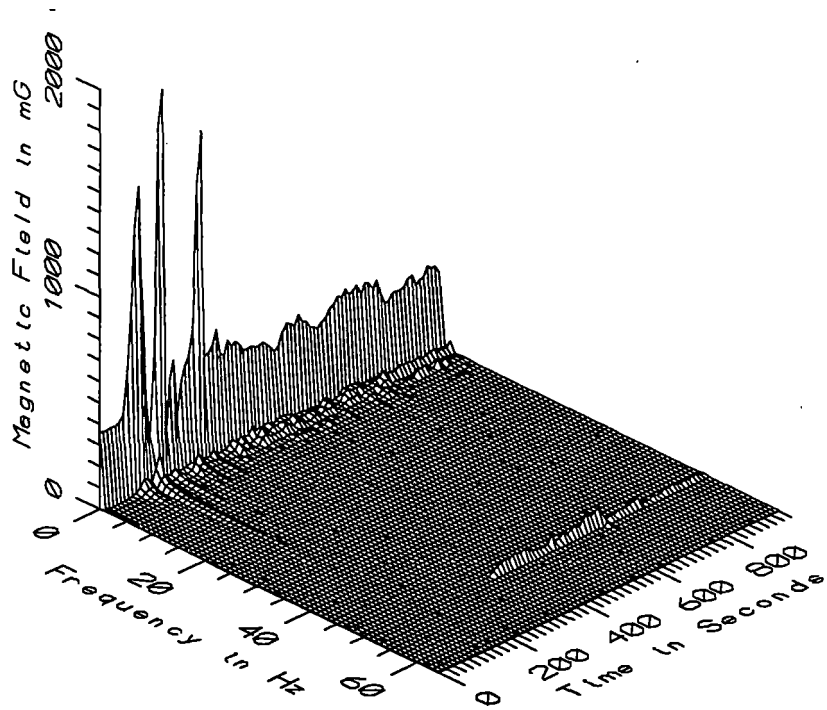

TGV025 - 110cm ABOVE FLOOR AGAINST ENGINEER'S CHAIR, REVENUE TRAIN

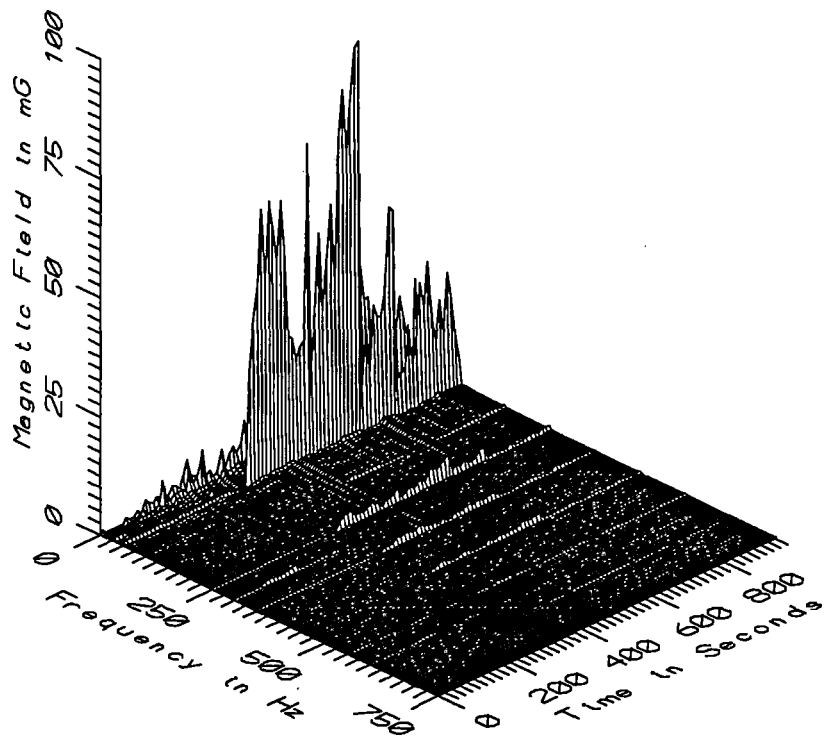

TGV025 - 110cm ABOVE FLOOR AGAINST ENGINEER'S CHAIR, REVENUE TRAIN

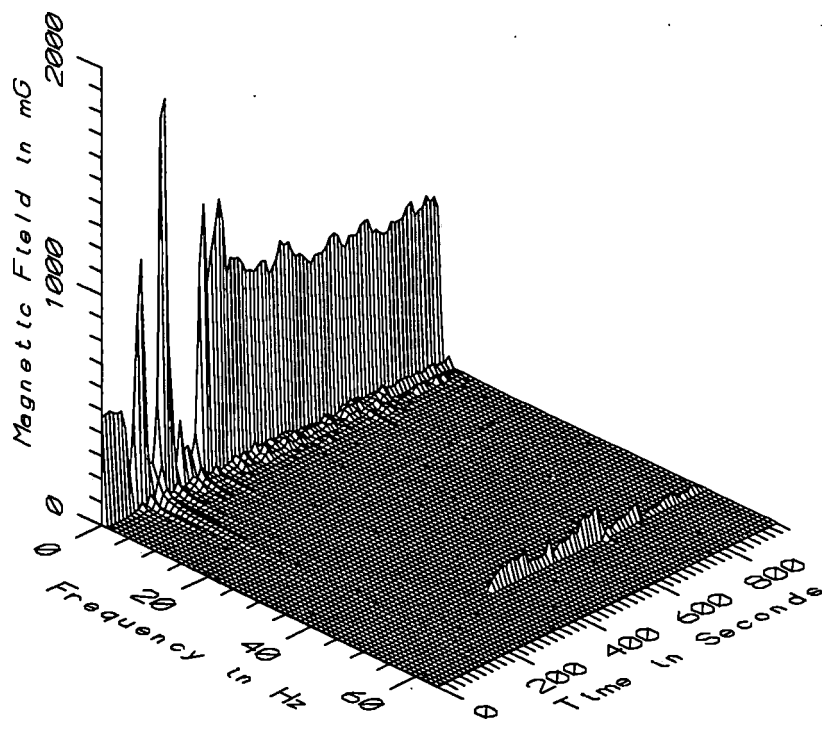

TGV025 - 160cm ABOVE FLOOR AGAINST ENGINEER'S CHAIR, REVENUE TRAIN

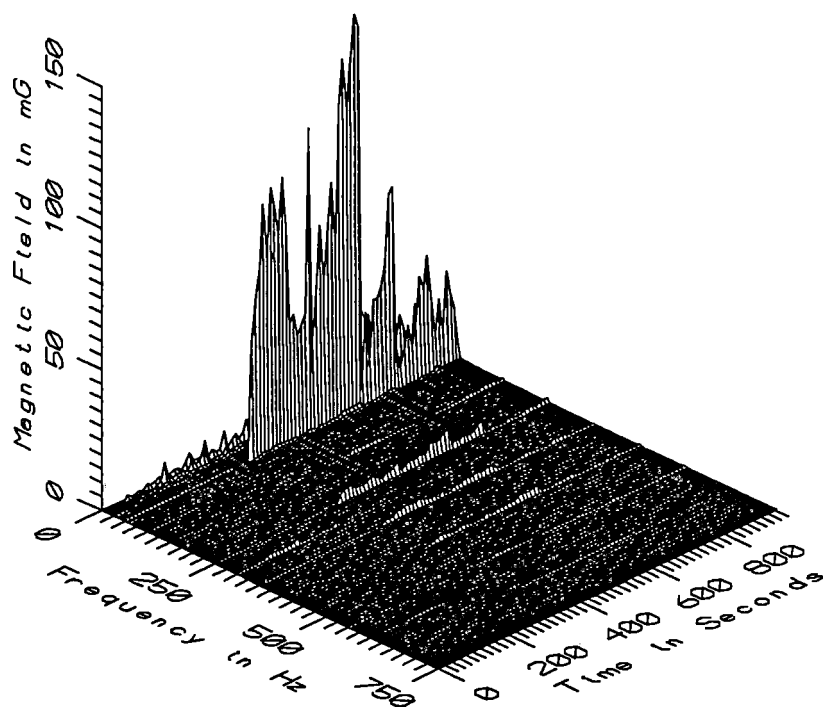

TGV025 - 160cm ABOVE FLOOR AGAINST ENGINEER'S CHAIR, REVENUE TRAIN

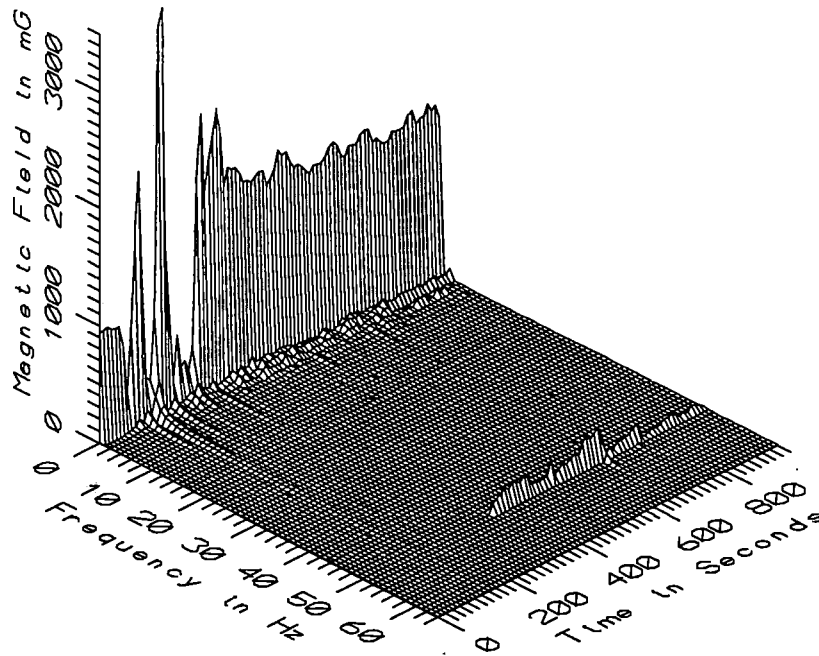

TGV025 - 160cm ABOVE FLOOR AGAINST ENGINEER'S CHAIR, REVENUE TRAIN

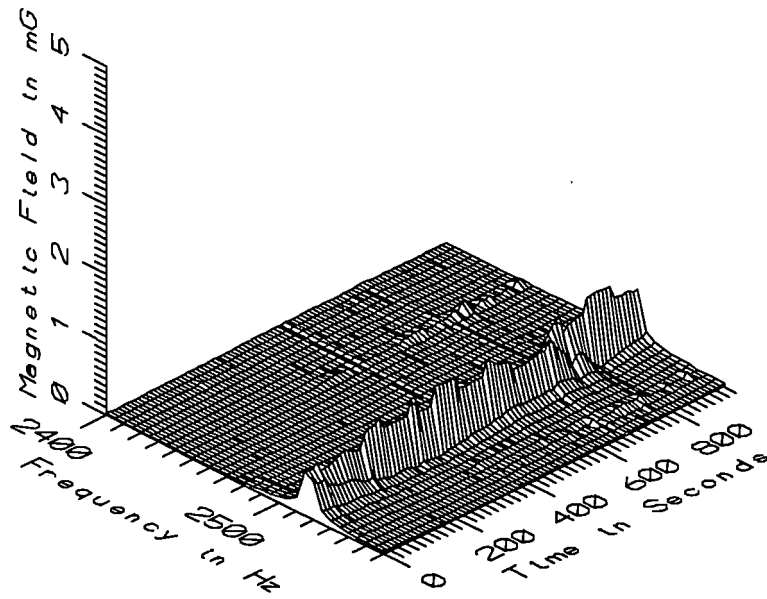

TGV025 - 160cm ABOVE FLOOR AGAINST ENGINEER'S CHAIR, REVENUE TRAIN

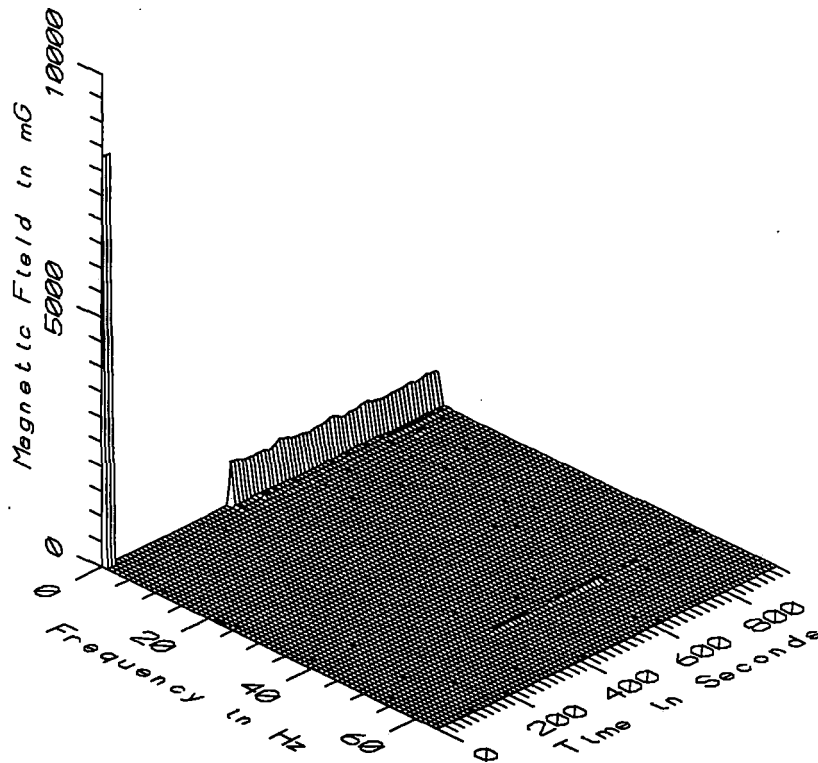

TGV025 - REF. PROBE - ASSISTANT ENGINEER'S CONSOLE, REVENUE TRAIN

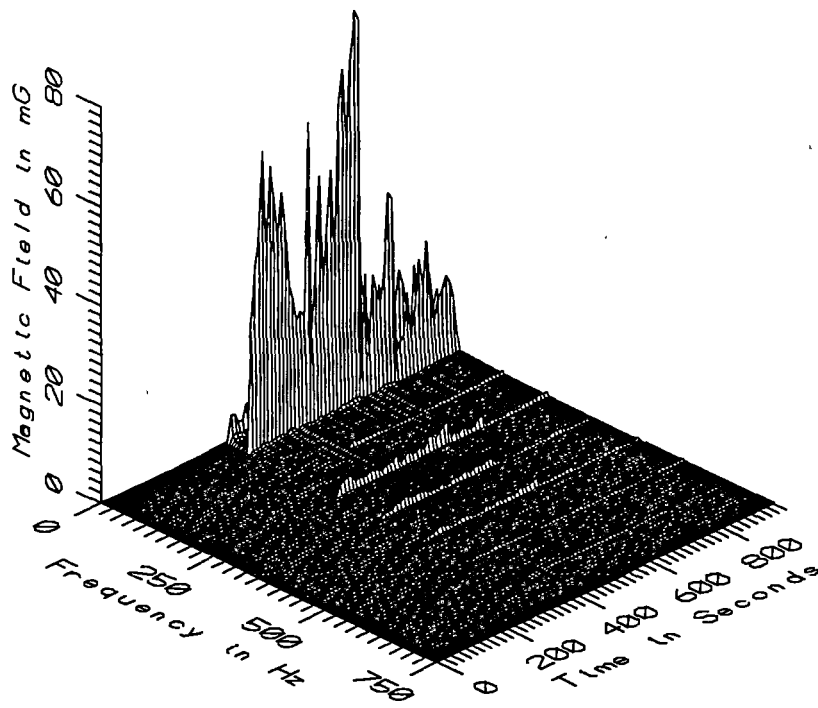

TGV025 - REF. PROBE - ASSISTANT ENGINEER'S CONSOLE, REVENUE TRAIN

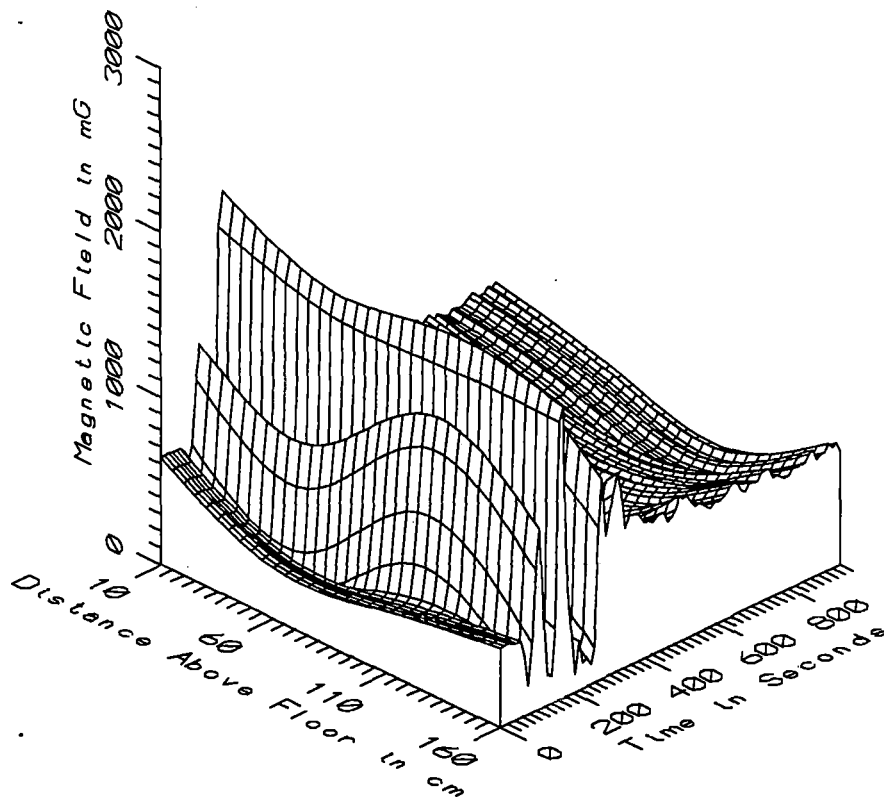

TGV025 - AGAINST ENGINEER'S CHAIR, REVENUE TRAIN - STATIC

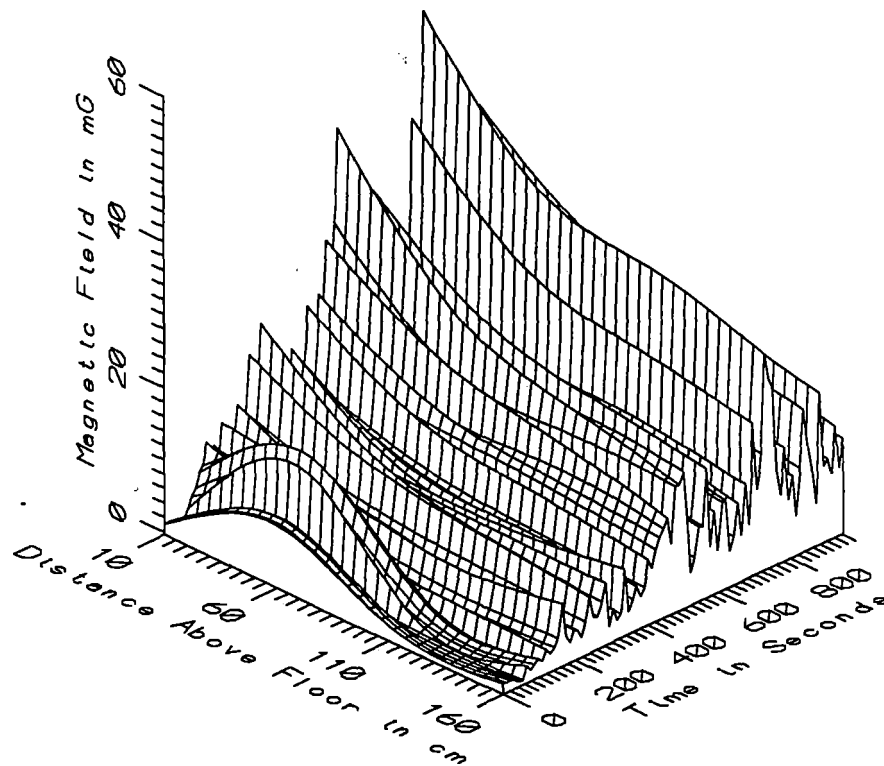

TGV025 - AGAINST ENGINEER'S CHAIR, REVENUE TRAIN - LOW FREQ, 5-45Hz

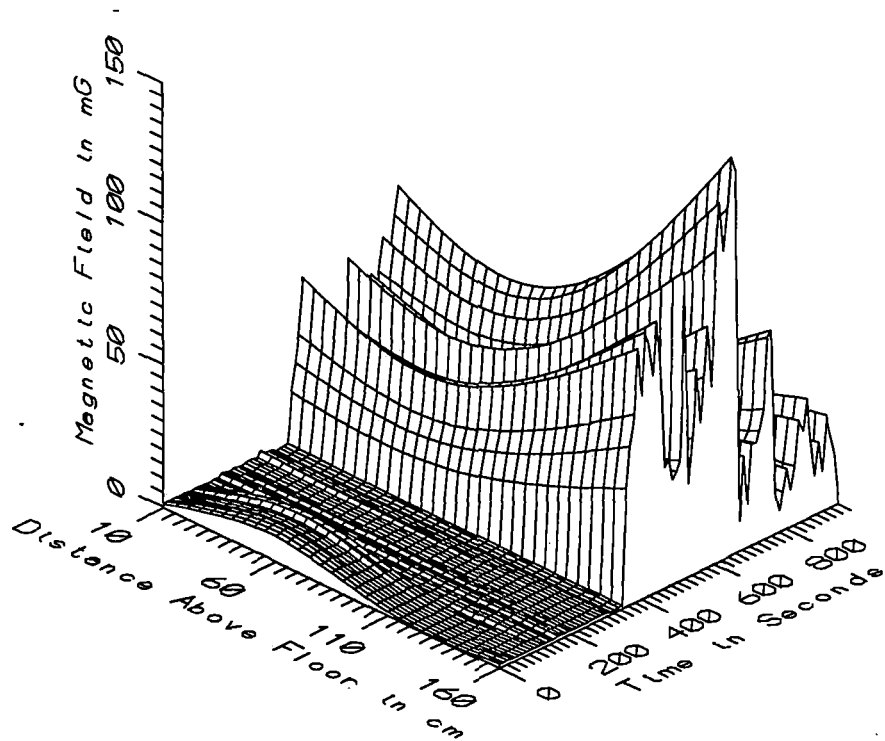

TGV025 - AGAINST ENGINEER'S CHAIR, REVENUE TRAIN - POWER FREQ, 50-60Hz

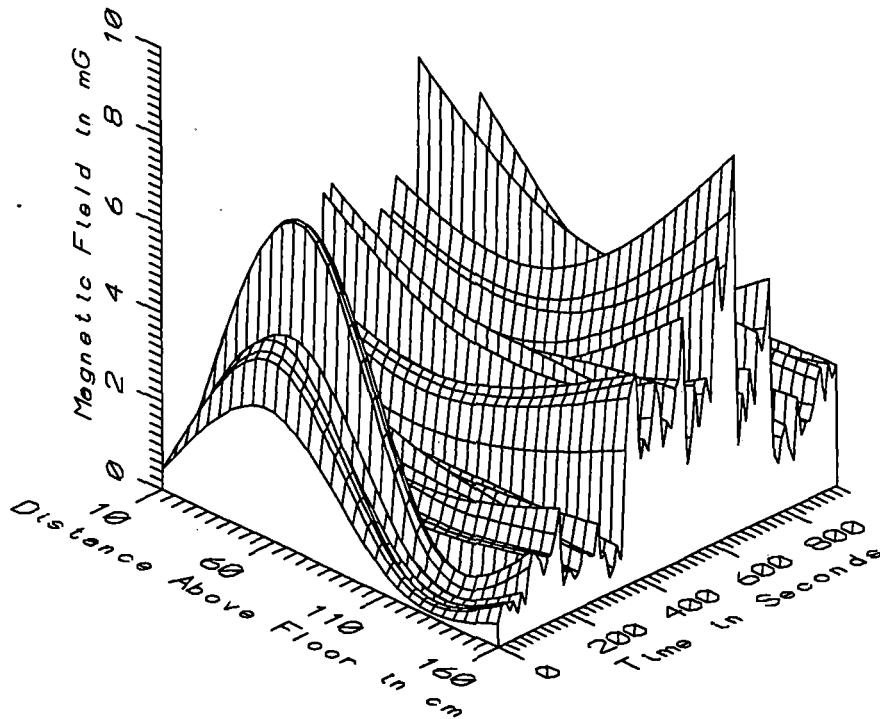

TGV025 - AGAINST ENGINEER'S CHAIR, REVENUE TRAIN - POWER HARM, 65-300Hz

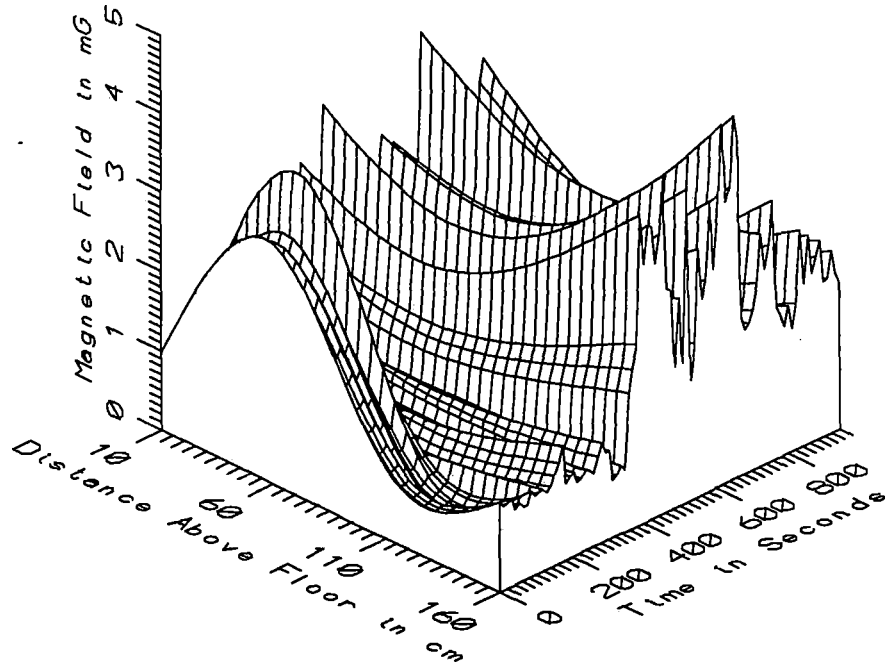

TGV025 - AGAINST ENGINEER'S CHAIR, REVENUE TRAIN - HIGH FREQ, 305-2560Hz

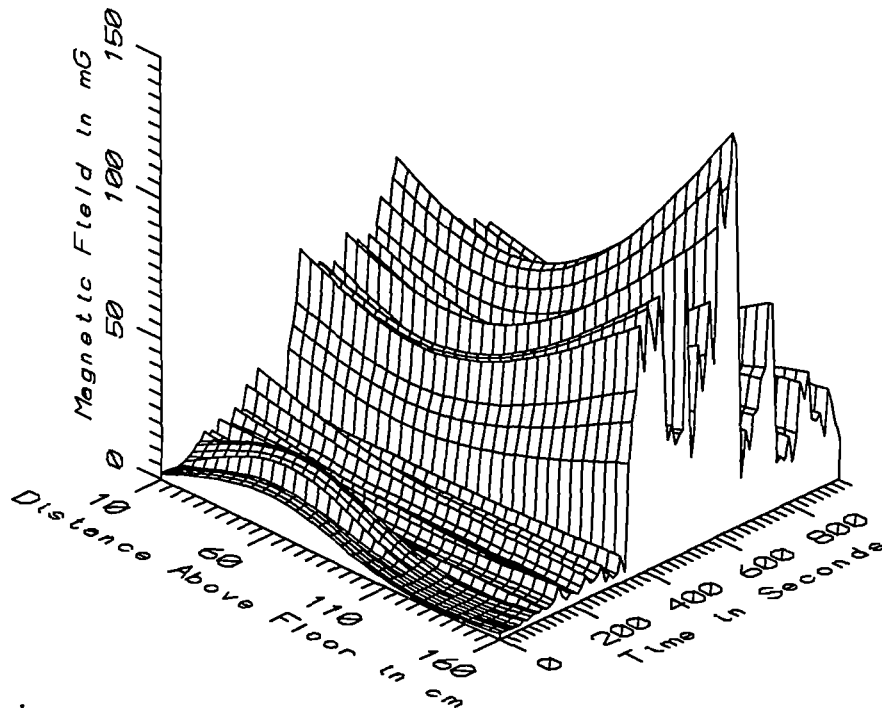

TGV025 - AGAINST ENGINEER'S CHAIR, REVENUE TRAIN - ALL FREQ, 5-2560Hz

TGV025 - ALL SAMPLES		TOTAL OF 88 SAMPLES				
FREQUENCY BAND	HEIGHT ABOVE FLOOR (cm)	MINIMUM MAGNETIC FIELD (mG)	MAXIMUM MAGNETIC FIELD (mG)	AVERAGE MAGNETIC FIELD (mG)	STANDARD DEVIATION (mG)	COEFFICIENT OF VARIATION (%)
STATIC	10	290.71	2062.19	745.71	255.77	34.30
	60	89.56	1776.04	549.27	250.99	45.70
	110	228.62	1855.00	503.16	295.27	58.68
	160	106.94	1732.20	705.34	275.66	39.08
5-45Hz LOW FREQ	10	0.43	54.50	17.01	11.15	65.54
	60	1.46	37.49	12.18	6.91	56.68
	110	0.28	33.90	9.64	6.95	72.07
	160	0.33	29.71	8.61	6.23	72.35
50-60Hz PWR FREQ	10	0.25	72.58	18.69	18.57	99.34
	60	0.14	57.98	16.27	14.37	88.28
	110	0.24	82.44	21.08	22.31	105.86
	160	0.13	139.71	33.49	37.80	112.86
65-300Hz PWR HARM	10	0.44	6.92	2.20	1.29	58.72
	60	0.24	6.79	2.18	1.30	59.52
	110	0.21	5.28	1.88	1.08	57.51
	160	0.37	8.57	2.55	1.69	66.29
305-2560Hz HIGH FREQ	10	0.59	3.48	1.44	0.60	41.65
	60	0.52	3.66	1.50	0.68	45.42
	110	0.57	2.85	1.42	0.63	44.23
	160	0.72	4.58	2.04	1.08	52.71
5-2560Hz ALL FREQ	10	1.45	73.97	27.51	18.94	68.84
	60	1.57	58.69	22.09	13.70	61.99
	110	1.25	82.93	24.84	21.73	87.46
	160	1.48	140.41	36.35	36.82	101.28



TGV025 - TRAIN AT REST		TOTAL OF 9 SAMPLES				
FREQUENCY BAND	HEIGHT ABOVE FLOOR (cm)	MINIMUM MAGNETIC FIELD (mG)	MAXIMUM MAGNETIC FIELD (mG)	AVERAGE MAGNETIC FIELD (mG)	STANDARD DEVIATION (mG)	COEFFICIENT OF VARIATION (%)
STATIC	10	510.16	640.58	616.86	41.45	6.72
	60	101.13	314.83	272.14	70.02	25.73
	110	349.86	870.29	439.48	176.57	40.18
	160	170.00	477.30	414.41	98.99	23.89
5-45Hz LOW FREQ	10	0.43	4.03	1.53	1.25	81.47
	60	1.90	15.01	8.20	4.17	50.88
	110	0.28	1.74	1.08	0.53	48.89
	160	0.33	2.09	1.14	0.56	49.22
50-60Hz PWR FREQ	10	0.79	1.21	1.05	0.12	11.37
	60	8.09	9.66	8.81	0.52	5.90
	110	0.83	1.06	0.93	0.08	8.14
	160	0.85	1.12	0.97	0.10	10.18
65-300Hz PWR HARM	10	0.46	1.02	0.62	0.18	28.28
	60	2.78	6.78	4.04	1.17	28.99
	110	0.43	1.07	0.62	0.19	30.20
	160	0.55	1.51	0.87	0.29	33.30
305-2560Hz HIGH FREQ	10	0.78	0.98	0.88	0.07	7.55
	60	2.57	3.66	2.90	0.32	10.91
	110	0.71	0.87	0.79	0.06	8.06
	160	0.92	1.13	1.02	0.08	7.87
5-2560Hz ALL FREQ	10	1.45	4.42	2.27	1.00	44.03
	60	9.72	18.05	13.39	2.85	21.29
	110	1.25	2.39	1.79	0.37	20.55
	160	1.48	2.78	2.06	0.43	20.69

TGV025 - TRAIN MOVING		TOTAL OF 79 SAMPLES				
FREQUENCY BAND	HEIGHT ABOVE FLOOR (cm)	MINIMUM MAGNETIC FIELD (mG)	MAXIMUM MAGNETIC FIELD (mG)	AVERAGE MAGNETIC FIELD (mG)	STANDARD DEVIATION (mG)	COEFFICIENT OF VARIATION (%)
STATIC	10	290.71	2062.19	760.39	265.82	34.96
	60	89.56	1776.04	580.84	244.73	42.13
	110	228.62	1855.00	510.41	305.82	59.92
	160	106.94	1732.20	738.48	269.95	36.55
5-45Hz LOW FREQ	10	2.21	54.50	18.77	10.38	55.28
	60	1.46	37.49	12.64	7.03	55.60
	110	1.68	33.90	10.61	6.66	62.77
	160	1.73	29.71	9.46	6.01	63.48
50-60Hz PWR FREQ	10	0.25	72.58	20.70	18.56	89.67
	60	0.14	57.98	17.13	14.93	87.20
	110	0.24	82.44	23.37	22.43	95.97
	160	0.13	139.71	37.20	38.18	102.64
65-300Hz PWR HARM	10	0.44	6.92	2.38	1.24	52.11
	60	0.24	6.79	1.97	1.13	57.70
	110	0.21	5.28	2.03	1.05	51.77
	160	0.37	8.57	2.74	1.68	61.22
305-2560Hz HIGH FREQ	10	0.59	3.48	1.51	0.60	39.85
	60	0.52	2.76	1.32	0.48	36.48
	110	0.57	2.85	1.50	0.62	41.54
	160	0.72	4.58	2.17	1.08	49.62
5-2560Hz ALL FREQ	10	2.35	73.97	30.39	17.83	58.69
	60	1.57	58.69	23.08	14.10	61.06
	110	1.81	82.93	27.47	21.41	77.93
	160	2.57	140.41	40.26	36.89	91.63

TGV025 - AC SECTION ONLY			TOTAL OF 55 SAMPLES			
FREQUENCY BAND	HEIGHT ABOVE FLOOR (cm)	MINIMUM MAGNETIC FIELD (mG)	MAXIMUM MAGNETIC FIELD (mG)	AVERAGE MAGNETIC FIELD (mG)	STANDARD DEVIATION (mG)	COEFFICIENT OF VARIATION (%)
STATIC	10	662.30	830.94	722.01	39.45	5.46
	60	486.44	668.90	553.25	39.81	7.20
	110	328.62	501.89	410.79	44.71	10.88
	160	673.14	897.41	755.92	56.38	7.46
5-45Hz LOW FREQ	10	4.17	54.50	23.10	9.11	39.45
	60	3.36	37.49	15.23	6.55	42.99
	110	3.55	33.90	13.33	6.10	45.76
	160	4.29	29.71	11.77	5.69	48.35
50-60Hz PWR FREQ	10	3.40	72.58	29.19	16.01	54.86
	60	4.94	57.98	23.87	12.95	54.27
	110	6.02	82.44	33.18	20.11	60.61
	160	4.86	139.71	53.05	35.54	67.00
65-300Hz PWR HARM	10	0.84	6.92	2.80	1.22	43.66
	60	0.70	4.93	2.13	0.79	36.90
	110	0.78	5.28	2.49	0.92	37.03
	160	1.08	8.57	3.41	1.56	45.71
305-2560Hz HIGH FREQ	10	1.03	3.48	1.79	0.53	29.34
	60	0.98	2.57	1.49	0.35	23.42
	110	1.13	2.85	1.84	0.46	25.09
	160	1.51	4.58	2.73	0.85	31.19
5-2560Hz ALL FREQ	10	14.34	73.97	39.66	12.70	32.03
	60	11.79	58.69	29.99	10.89	36.32
	110	12.19	82.93	37.41	18.12	48.44
	160	13.90	140.41	55.80	33.97	60.88

TGV025 - TRANSITION BETWEEN DC AND AC SECTIONS					TOTAL OF 6 SAMPLES	
FREQUENCY BAND	HEIGHT ABOVE FLOOR (cm)	MINIMUM MAGNETIC FIELD (mG)	MAXIMUM MAGNETIC FIELD (mG)	AVERAGE MAGNETIC FIELD (mG)	STANDARD DEVIATION (mG)	COEFFICIENT OF VARIATION (%)
STATIC	10	779.41	879.61	830.77	39.94	4.81
	60	610.97	824.63	720.78	74.10	10.28
	110	441.49	578.07	494.40	48.26	9.76
	160	831.31	1177.36	992.23	138.26	13.93
5-45Hz LOW FREQ	10	2.21	8.25	4.83	2.37	49.15
	60	1.46	7.17	3.56	1.96	54.98
	110	1.68	7.30	3.48	1.96	56.42
	160	2.17	9.13	4.00	2.62	65.50
50-60Hz PWR FREQ	10	0.25	1.43	0.82	0.45	54.99
	60	0.14	0.89	0.56	0.30	52.68
	110	0.24	1.04	0.61	0.32	53.40
	160	0.13	1.01	0.57	0.35	61.64
65-300Hz PWR HARM	10	0.44	1.60	0.95	0.39	41.22
	60	0.24	1.04	0.66	0.28	42.19
	110	0.21	1.07	0.68	0.30	44.63
	160	0.37	1.02	0.74	0.26	34.61
305-2560Hz HIGH FREQ	10	0.59	0.98	0.80	0.16	19.83
	60	0.52	0.82	0.68	0.13	18.62
	110	0.57	0.90	0.73	0.14	19.57
	160	0.72	1.12	0.89	0.18	20.19
5-2560Hz ALL FREQ	10	2.35	8.51	5.09	2.35	46.18
	60	1.57	7.31	3.75	1.95	52.05
	110	1.81	7.44	3.70	1.95	52.59
	160	2.57	9.26	4.26	2.55	59.92

TGV025 - DC SECTION ONLY			TOTAL OF 18 SAMPLES			
FREQUENCY BAND	HEIGHT ABOVE FLOOR (cm)	MINIMUM MAGNETIC FIELD (mG)	MAXIMUM MAGNETIC FIELD (mG)	AVERAGE MAGNETIC FIELD (mG)	STANDARD DEVIATION (mG)	COEFFICIENT OF VARIATION (%)
STATIC	10	290.71	2062.19	854.19	550.41	64.44
	60	89.56	1776.04	618.50	507.21	82.01
	110	228.62	1855.00	820.13	536.96	65.47
	160	106.94	1732.20	600.61	524.22	87.28
5-45Hz LOW FREQ	10	5.08	22.28	10.19	4.63	45.44
	60	3.42	15.55	7.74	3.59	46.39
	110	2.33	9.43	4.67	2.21	47.28
	160	1.73	8.52	4.26	2.11	49.59
50-60Hz PWR FREQ	10	0.80	2.91	1.41	0.49	34.89
	60	0.82	8.92	2.05	2.42	118.19
	110	0.63	1.37	1.00	0.21	21.17
	160	0.66	1.35	0.98	0.16	16.50
65-300Hz PWR HARM	10	1.05	3.14	1.56	0.50	32.21
	60	0.85	6.79	1.89	1.79	94.99
	110	0.65	1.61	1.08	0.26	23.76
	160	0.72	2.51	1.35	0.48	35.66
305-2560Hz HIGH FREQ	10	0.80	1.33	0.96	0.15	15.37
	60	0.76	2.76	1.09	0.60	54.98
	110	0.71	1.01	0.83	0.08	10.02
	160	0.91	1.46	1.05	0.14	13.57
5-2560Hz ALL FREQ	10	5.41	22.73	10.48	4.63	44.14
	60	3.79	19.10	8.43	4.47	52.98
	110	2.79	9.62	5.01	2.13	42.55
	160	2.80	8.94	4.77	1.98	41.40

APPENDIX AA

DATASET TGV026  
 REVENUE TRAIN LOCOMOTIVE, AGAINST ENGINEER'S CHAIR

Measurement Setup Code: Staff: 25      Reference: 26  
 Drawing: A-2

Vehicle Status: Locomotive trip from Montparnasse  
 station in Paris to Vendome station

Measurement Date: September 9, 1992

Measurement Time: Start: 08:01:17  
 End: 08:20:33

Number of Samples: 40

Programmed Sample Interval: 30 sec

Actual Sample Interval: 29.6 sec

Frequency Spectrum Parameters

<u>Probe Type:</u>	<u>Wideband</u>	<u>Static</u>
Maximum Frequency (Hz)	2560	64
Minimum Frequency (Hz)	5	0
Spectral Bandwidth (Hz)	5	1

Missing or Suspect Data: None

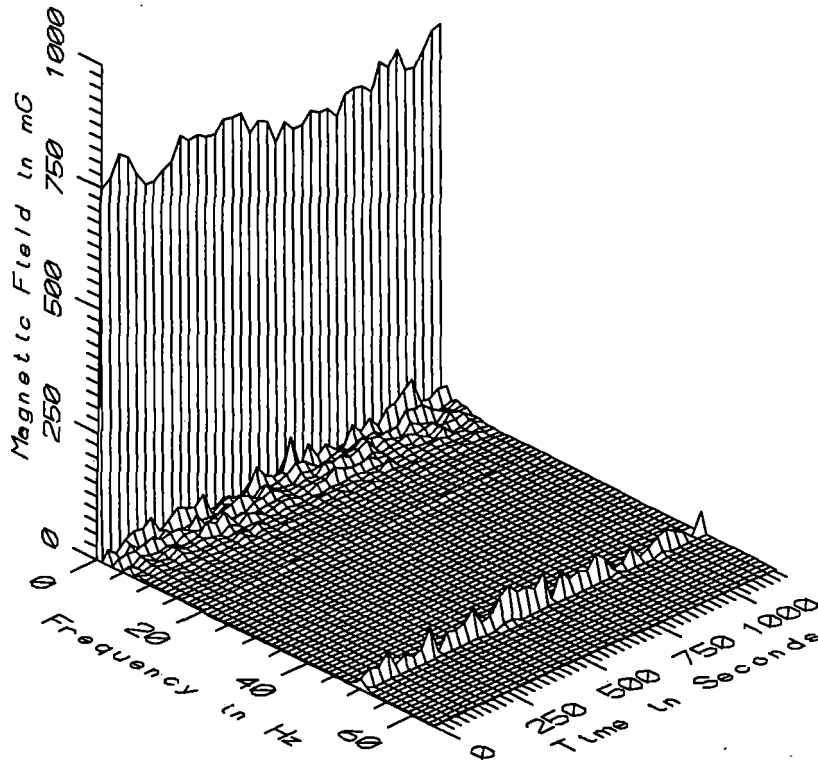

TGV026 - 10cm ABOVE FLOOR AGAINST ENGINEER'S CHAIR, REVENUE TRAIN

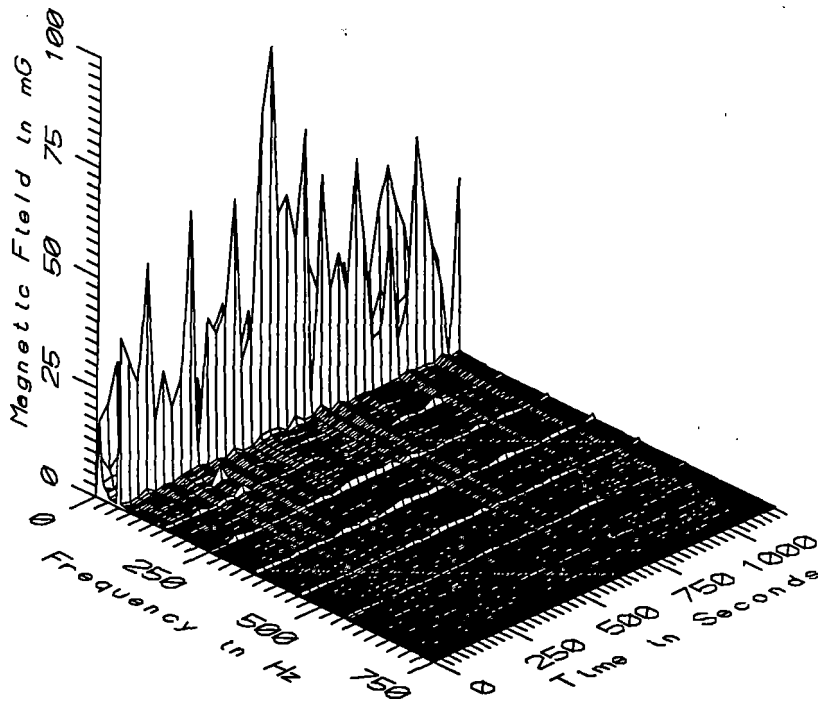

TGV026 - 10cm ABOVE FLOOR AGAINST ENGINEER'S CHAIR, REVENUE TRAIN

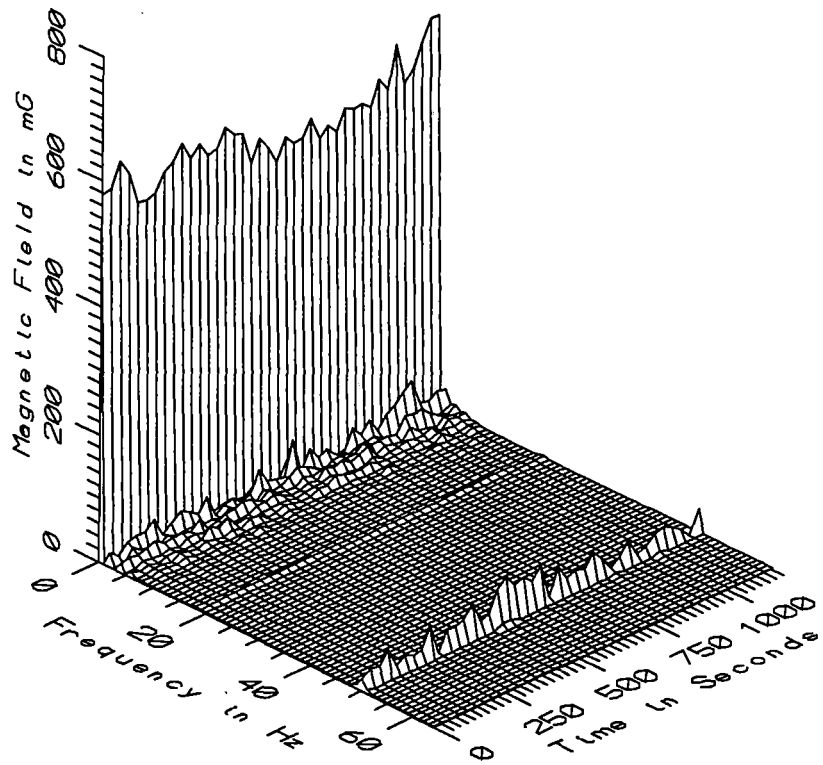

TGV026 - 60cm ABOVE FLOOR AGAINST ENGINEER'S CHAIR, REVENUE TRAIN

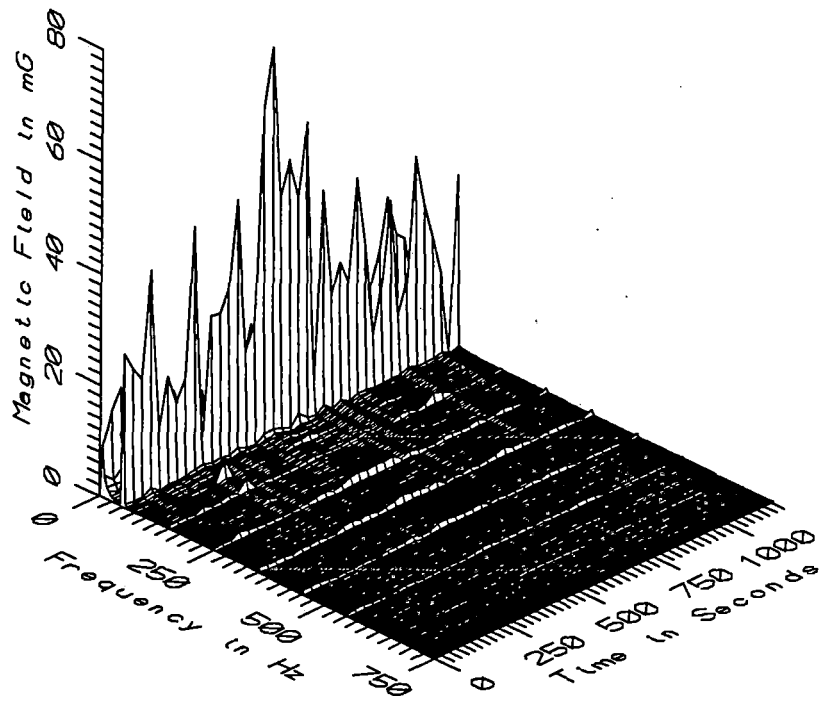

TGV026 - 60cm ABOVE FLOOR AGAINST ENGINEER'S CHAIR, REVENUE TRAIN



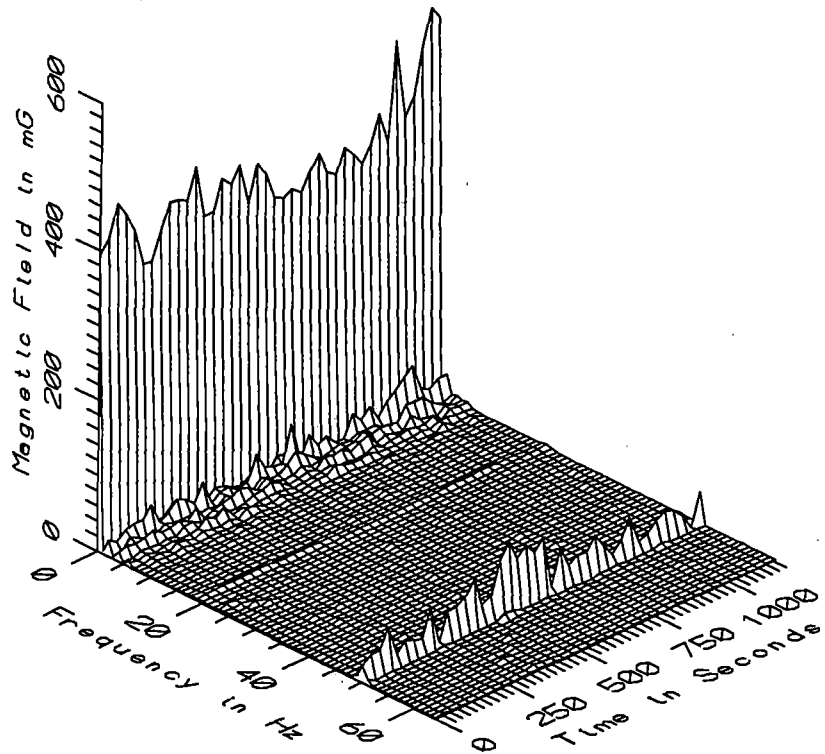

TGV026 - 110cm ABOVE FLOOR AGAINST ENGINEER'S CHAIR, REVENUE TRAIN

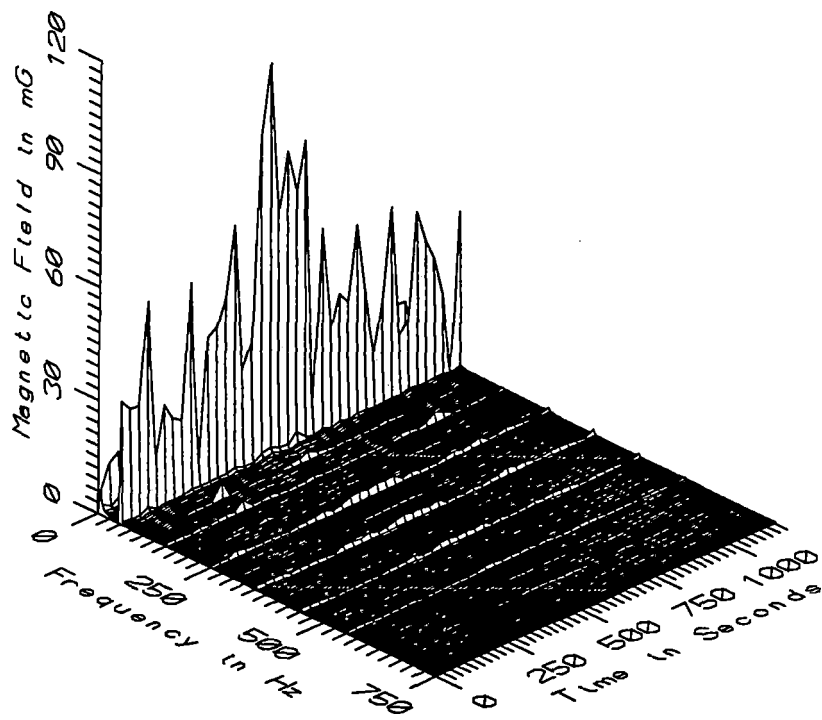

TGV026 - 110cm ABOVE FLOOR AGAINST ENGINEER'S CHAIR, REVENUE TRAIN

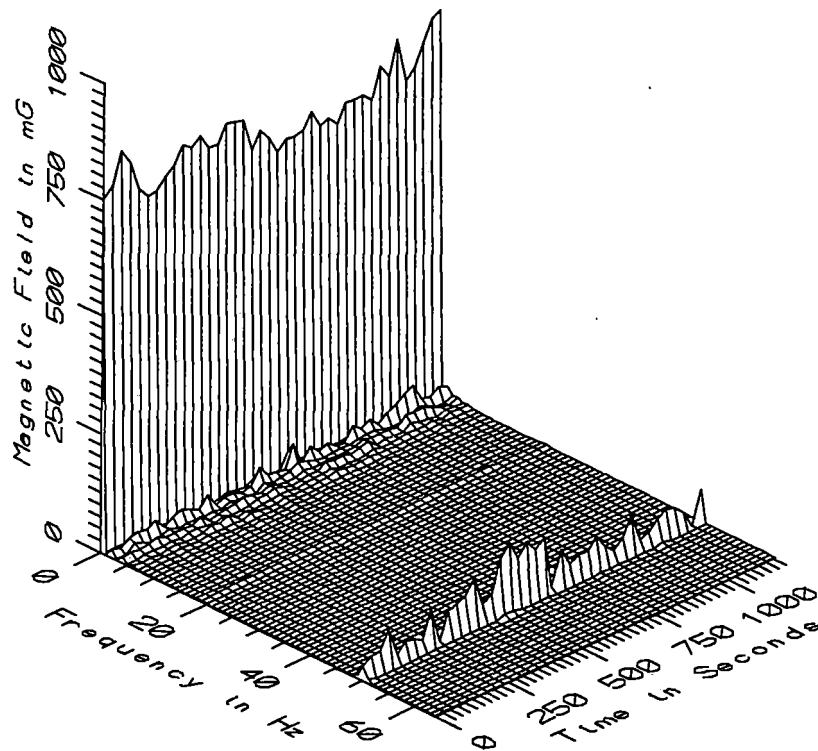

TGV026 - 160cm ABOVE FLOOR AGAINST ENGINEER'S CHAIR, REVENUE TRAIN

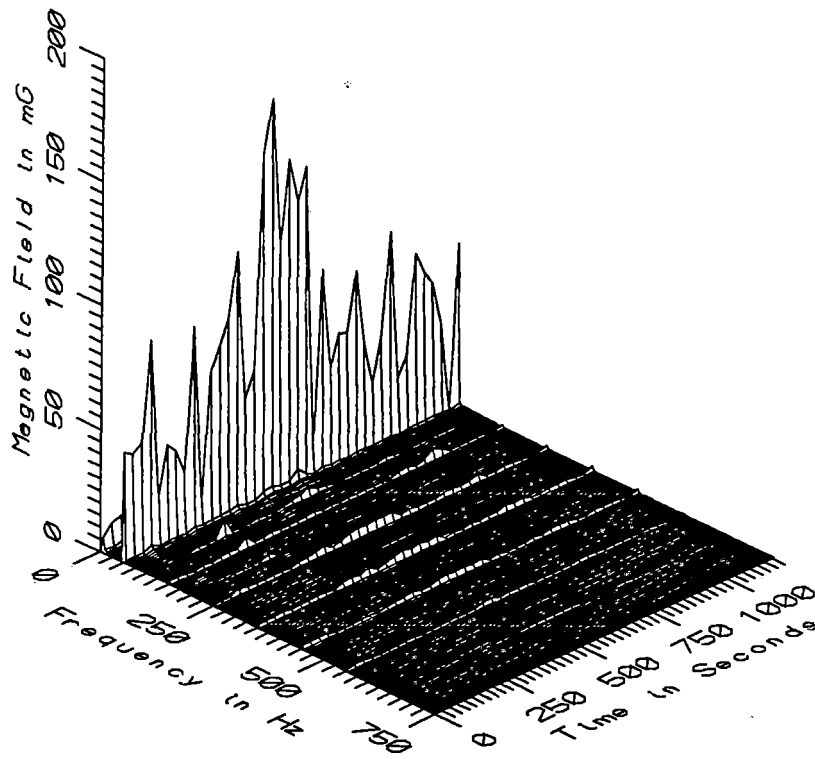

TGV026 - 160cm ABOVE FLOOR AGAINST ENGINEER'S CHAIR, REVENUE TRAIN

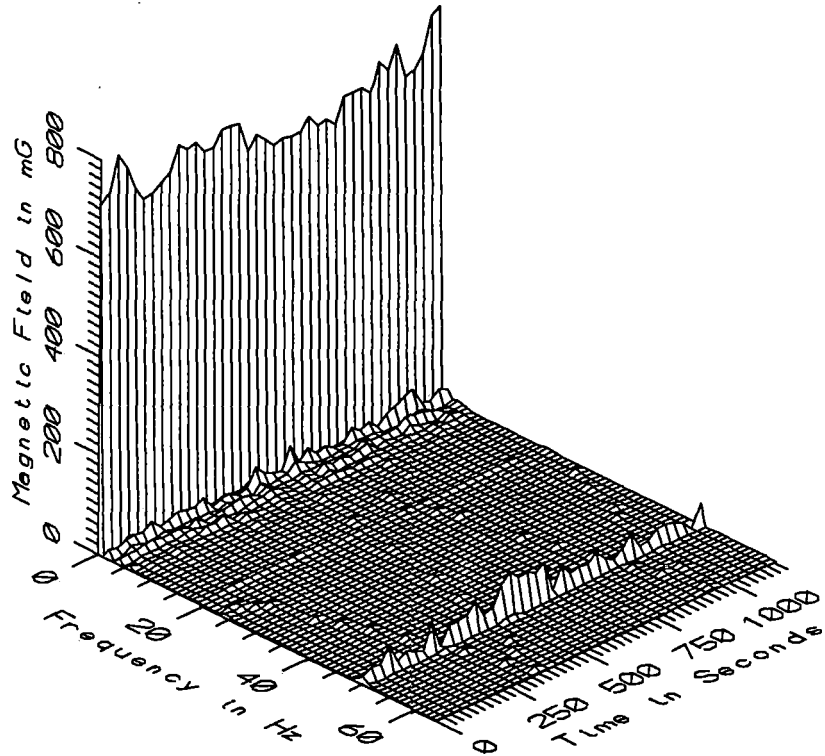

TGV026 - REF. PROBE - ASSISTANT ENGINEER'S CONSOLE, REVENUE TRAIN

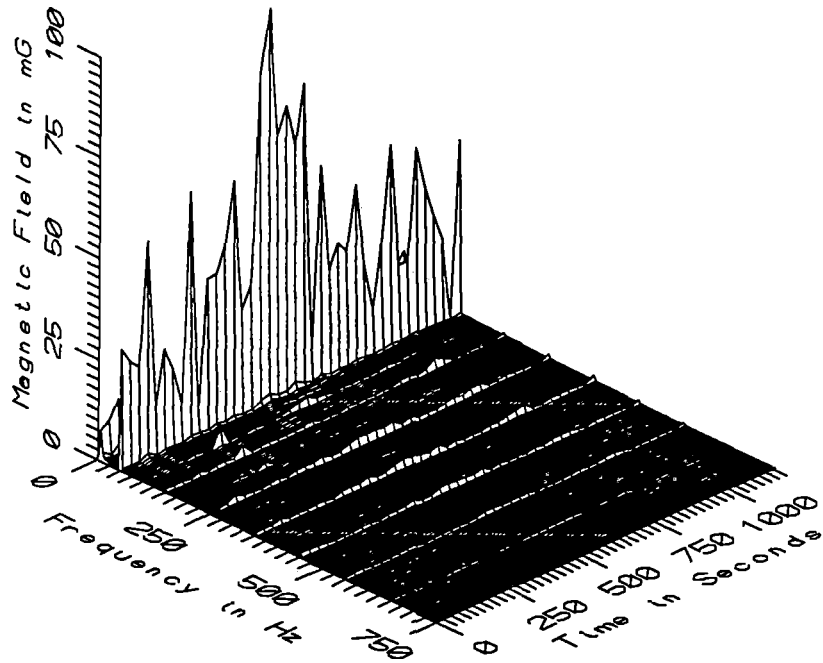

TGV026 - REF. PROBE - ASSISTANT ENGINEER'S CONSOLE, REVENUE TRAIN

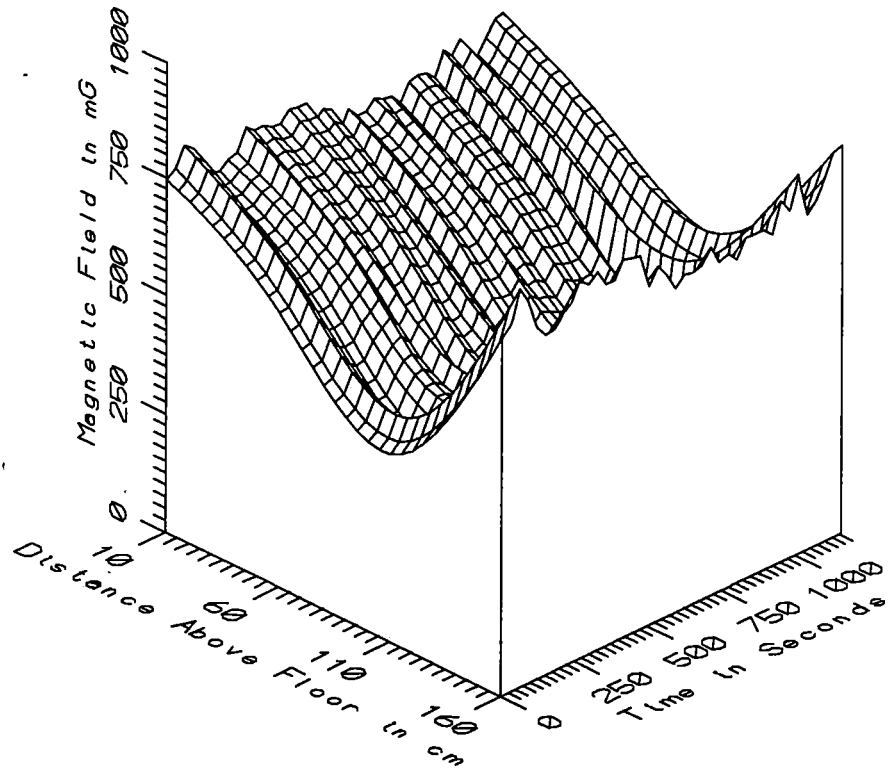

TGV026 - AGAINST ENGINEER'S CHAIR, REVENUE TRAIN - STATIC

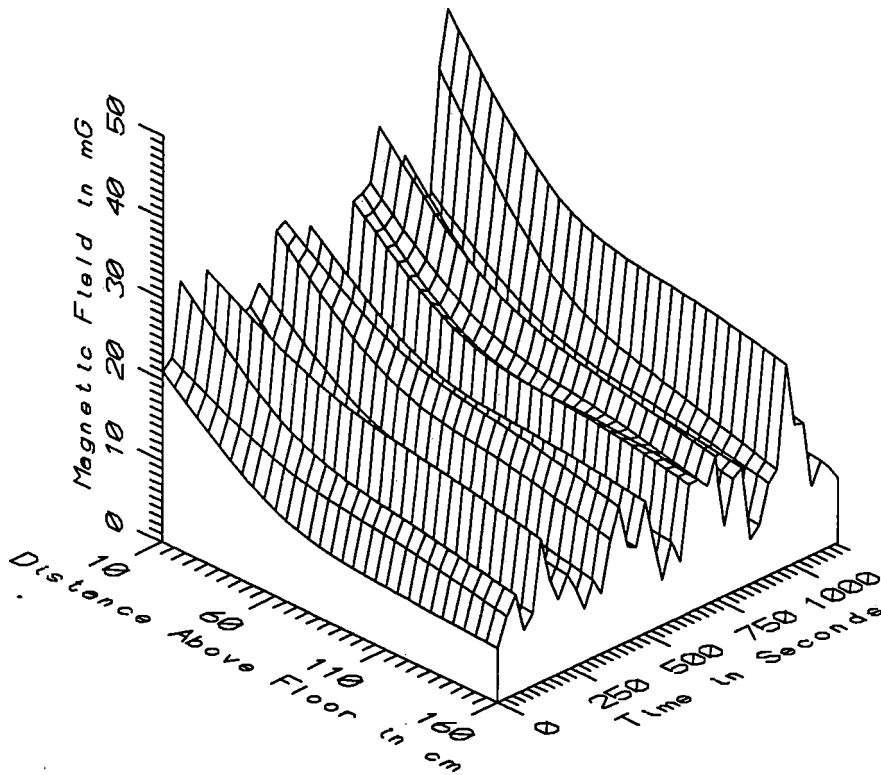

TGV026 - AGAINST ENGINEER'S CHAIR, REVENUE TRAIN - LOW FREQ, 5-45Hz

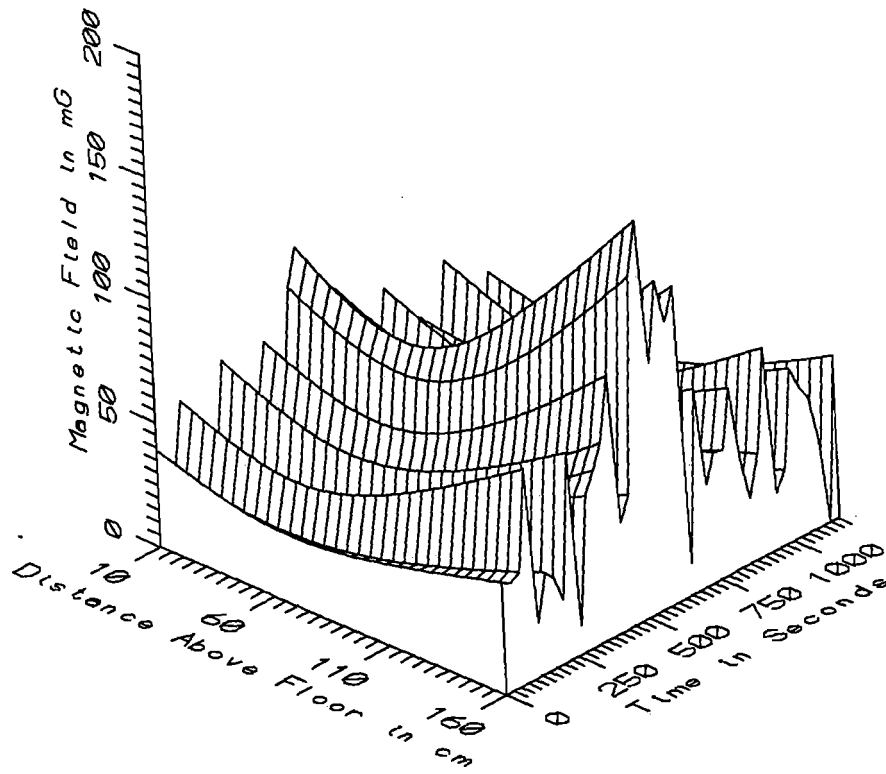

TGV026 - AGAINST ENGINEER'S CHAIR, REVENUE TRAIN - POWER FREQ, 50-60Hz

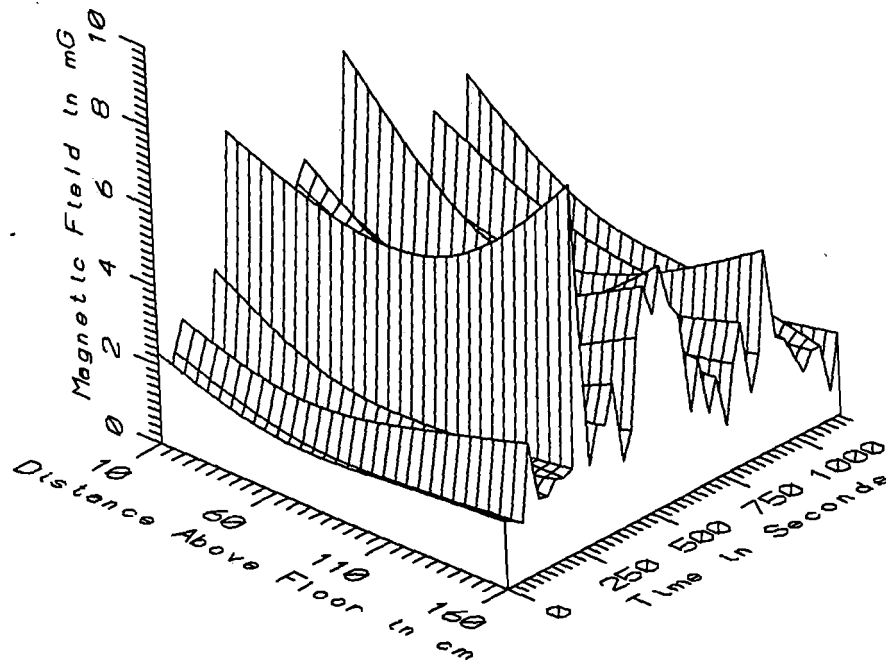

TGV026 - AGAINST ENGINEER'S CHAIR, REVENUE TRAIN - POWER HARM, 65-300Hz

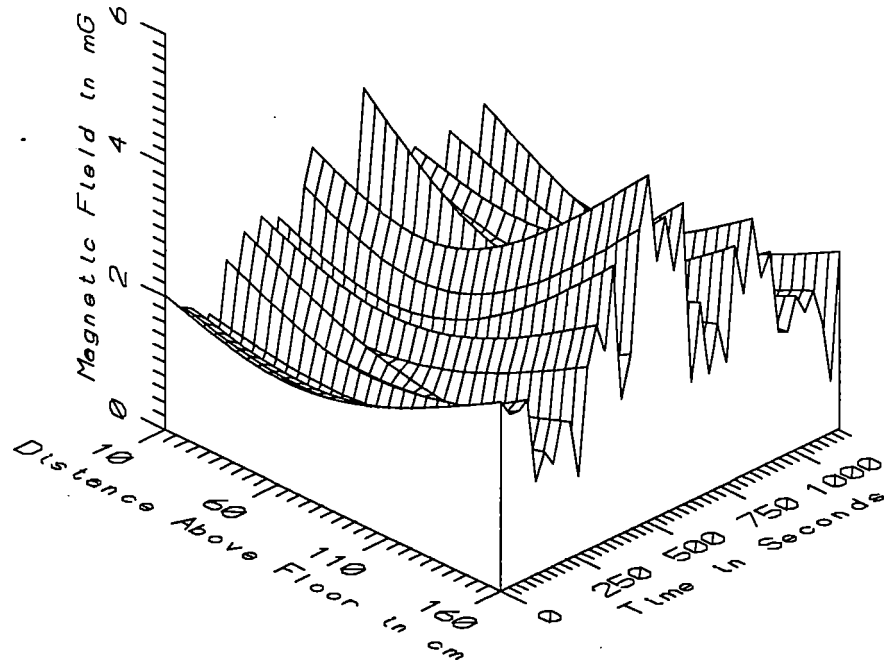

TGV026 - AGAINST ENGINEER'S CHAIR, REVENUE TRAIN - HIGH FREQ, 305-2560Hz

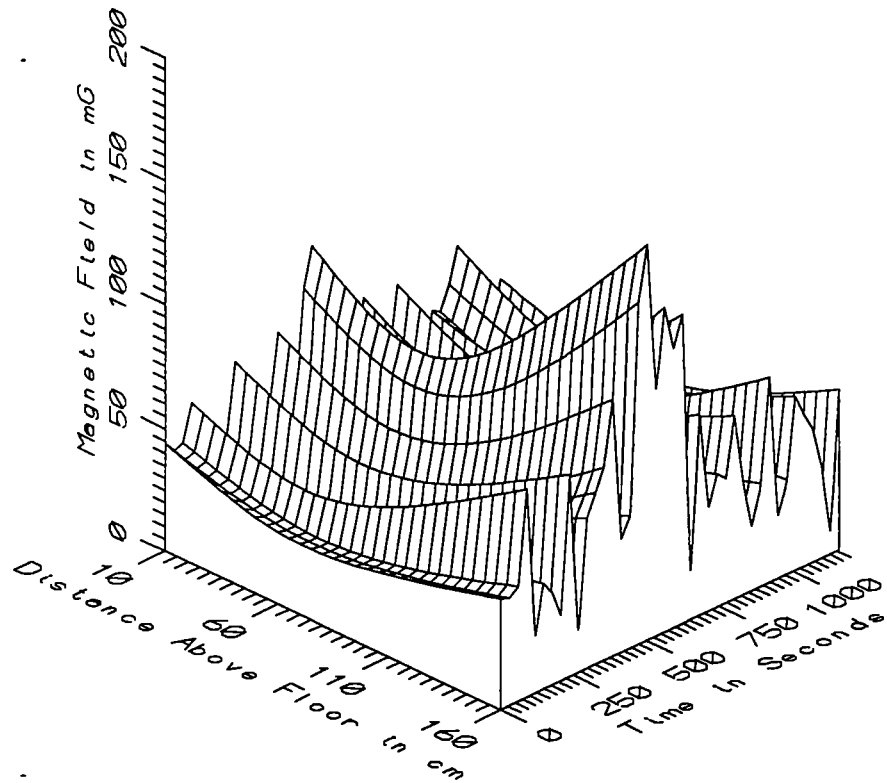

TGV026 - AGAINST ENGINEER'S CHAIR, REVENUE TRAIN - ALL FREQ, 5-2560Hz

TGV026 - ALL SAMPLES IN AC SECTION				TOTAL OF 40 SAMPLES		
FREQUENCY BAND	HEIGHT ABOVE FLOOR (cm)	MINIMUM MAGNETIC FIELD (mG)	MAXIMUM MAGNETIC FIELD (mG)	AVERAGE MAGNETIC FIELD (mG)	STANDARD DEVIATION (mG)	COEFFICIENT OF VARIATION (%)
STATIC	10	678.61	802.40	736.11	31.19	4.24
	60	505.36	620.89	559.11	32.45	5.80
	110	353.34	526.35	405.05	42.78	10.56
	160	682.17	837.84	747.01	41.91	5.61
5-45Hz LOW FREQ	10	12.55	48.76	26.18	7.81	29.82
	60	6.83	32.22	16.45	5.42	32.94
	110	5.89	27.95	13.79	4.75	34.47
	160	5.56	25.05	11.73	4.20	35.80
50-60Hz PWR FREQ	10	0.76	89.60	34.77	19.92	57.28
	60	0.41	70.05	27.95	15.24	54.53
	110	0.48	104.12	39.28	22.92	58.35
	160	0.58	159.82	61.46	36.80	59.88
65-300Hz PWR HARM	10	0.86	7.27	2.81	1.55	54.94
	60	0.47	5.81	2.00	1.06	53.20
	110	0.52	6.23	2.17	1.10	50.55
	160	0.73	9.23	2.89	1.65	57.17
305-2560Hz HIGH FREQ	10	0.73	3.74	1.89	0.65	34.17
	60	0.60	2.61	1.51	0.43	28.52
	110	0.59	3.48	1.84	0.59	31.87
	160	0.77	5.22	2.67	1.00	37.58
5-2560Hz ALL FREQ	10	19.31	94.73	45.81	16.20	35.35
	60	13.49	73.10	33.91	12.98	38.28
	110	11.55	105.80	42.94	21.09	49.13
	160	9.89	160.83	63.58	35.52	55.86

APPENDIX AB

DATASET TGV027  
AT CHAILLOT AUTOTRANSFORMER

Measurement Setup Code:      Staff: 27      Reference: 28  
   Drawing: A-6

Vehicle Status:                      Not Applicable

Measurement Date:                    September 9, 1992

Measurement Time:                    Start:      10:15:49  
   End:        10:17:40

Number of Samples:                    12

Programmed Sample Interval:        10 sec

Actual Sample Interval:              10.1 sec

Frequency Spectrum Parameters

<u>Probe Type:</u>	<u>Wideband</u>	<u>Static</u>
Maximum Frequency (Hz)	2560	64
Minimum Frequency (Hz)	5	0
Spectral Bandwidth (Hz)	5	1

Missing or Suspect Data:            None



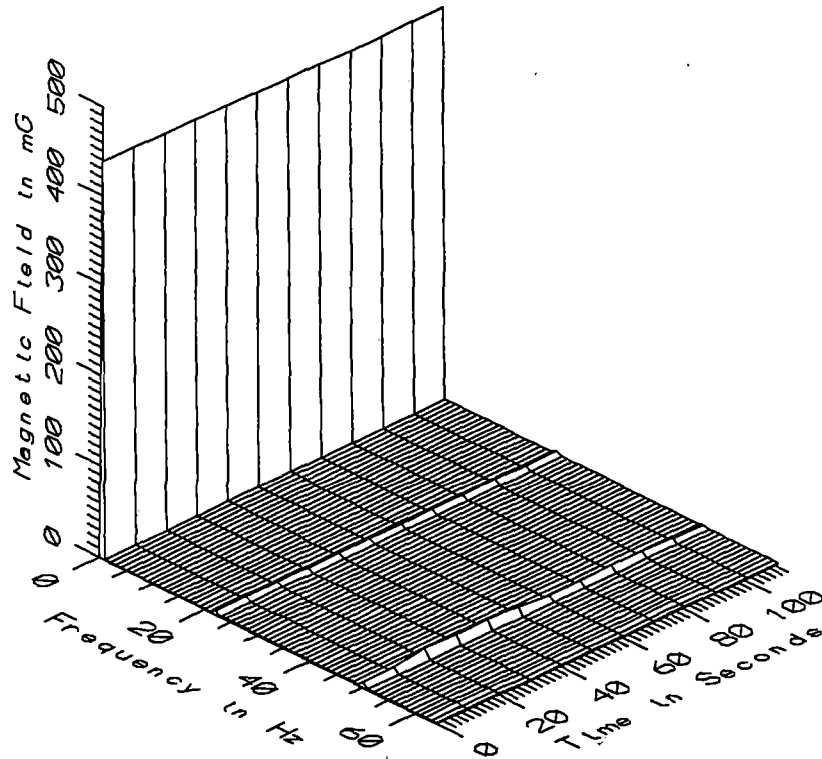

TGV027 - 10cm ABOVE GROUND AT CHAILLOT AUTO-TRANSFORMER, 121km MARKER

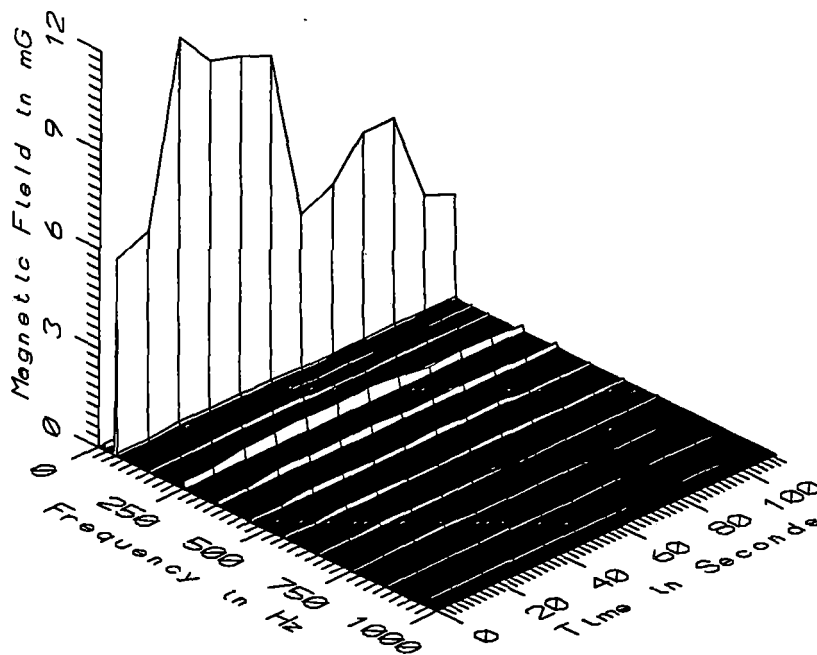

TGV027 - 10cm ABOVE GROUND AT CHAILLOT AUTO-TRANSFORMER, 121km MARKER

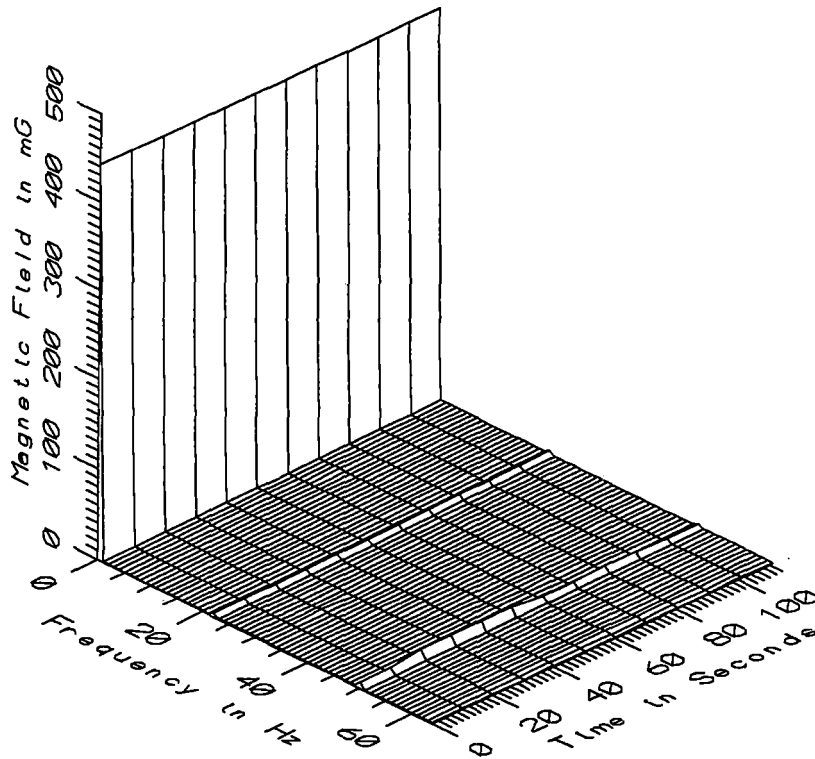

TGV027 - 60cm ABOVE GROUND AT CHAILLOT AUTO-TRANSFORMER, 121km MARKER

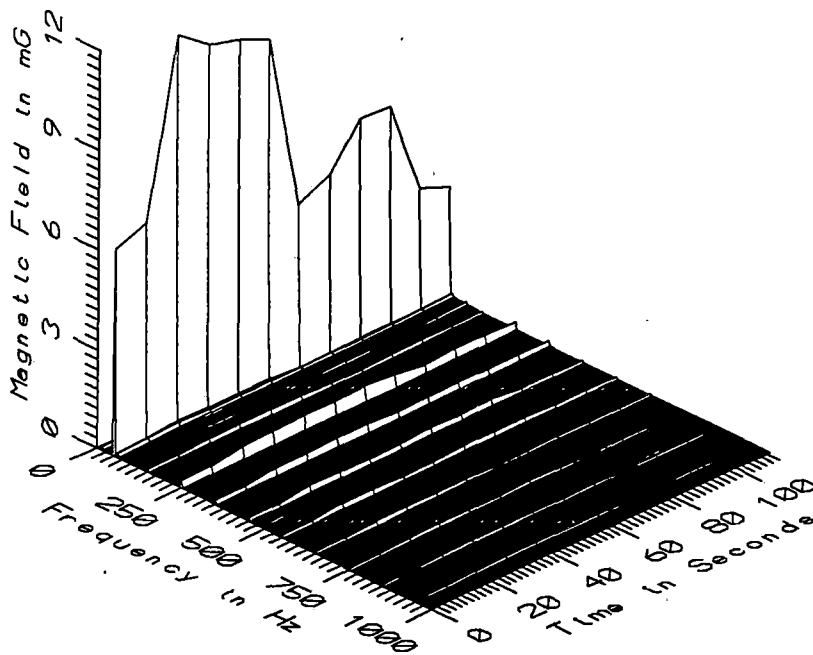

TGV027 - 60cm ABOVE GROUND AT CHAILLOT AUTO-TRANSFORMER, 121km MARKER

1 2 3 4 5 6 7 8 9 10 11 12 13 14 15 16 17 18 19 20 21 22 23 24 25 26 27 28 29 30 31 32 33 34 35 36 37 38 39 40 41 42 43 44 45 46 47 48 49 50 51 52 53 54 55 56 57 58 59 60 61 62 63 64 65 66 67 68 69 70 71 72 73 74 75 76 77 78 79 80 81 82 83 84 85 86 87 88 89 90 91 92 93 94 95 96 97 98 99 100

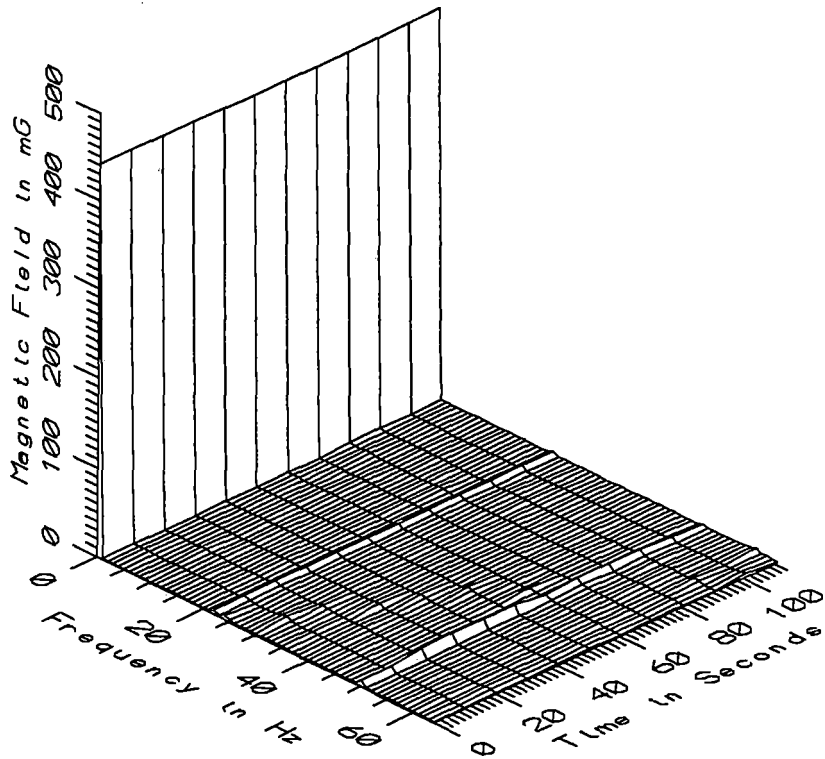

TGV027 - 110cm ABOVE GROUND AT CHAILLOT AUTO-TRANSFORMER, 121km MARKER

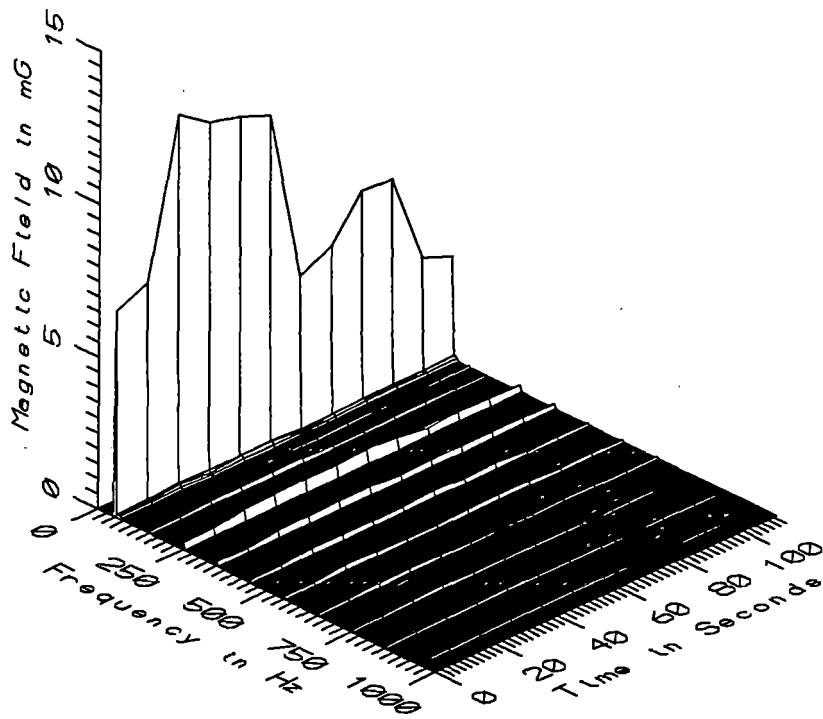

TGV027 - 110cm ABOVE GROUND AT CHAILLOT AUTO-TRANSFORMER, 121km MARKER

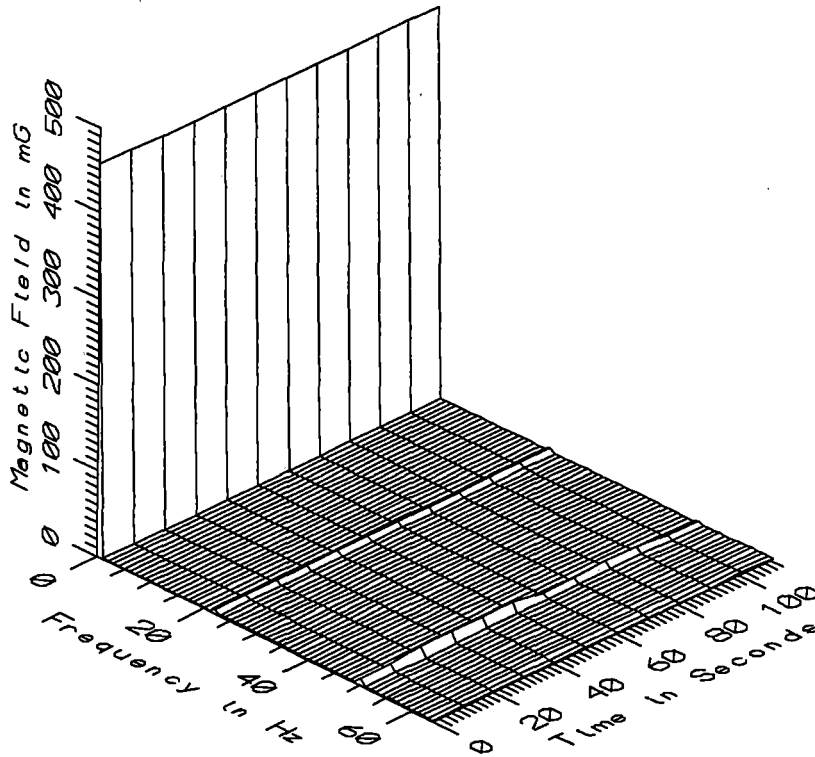

TGV027 - 160cm ABOVE GROUND AT CHAILLOT AUTO-TRANSFORMER, 121km MARKER

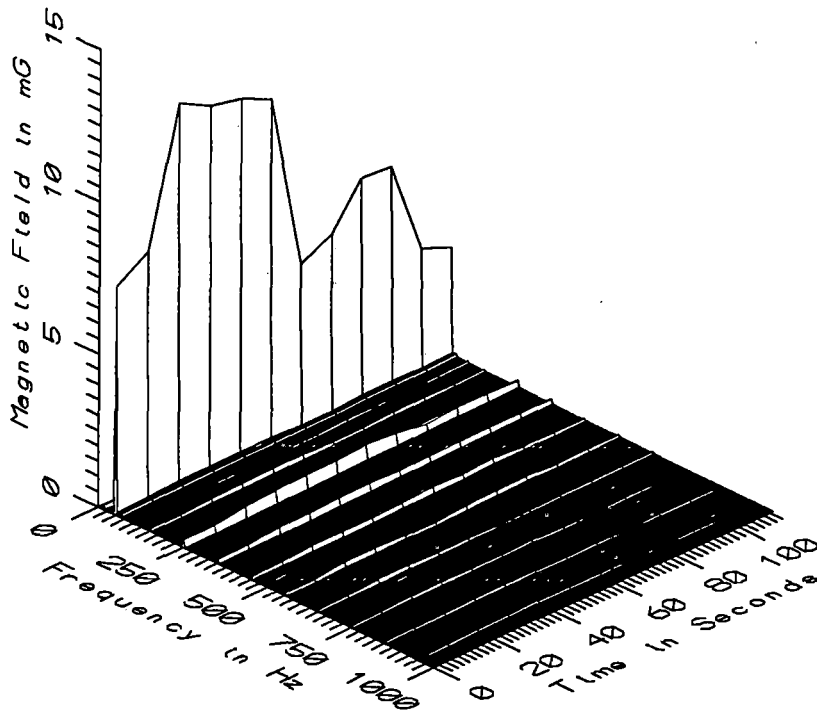

TGV027 - 160cm ABOVE GROUND AT CHAILLOT AUTO-TRANSFORMER, 121km MARKER

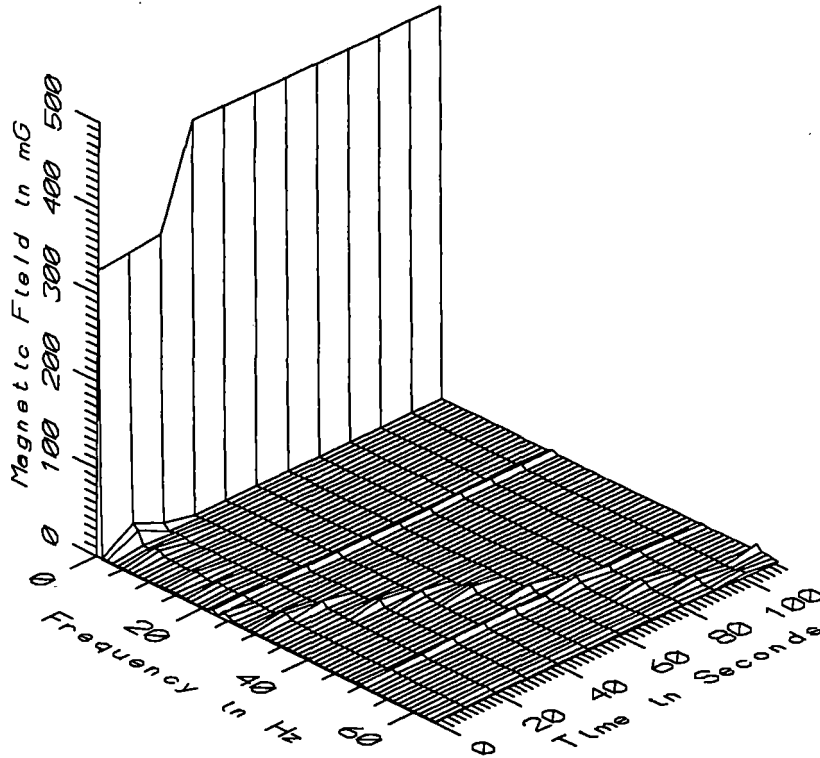

TGV027 - REFERENCE PROBE - 15m FROM STAFF AT CHAILLOT AUTO-TRANSFORMER

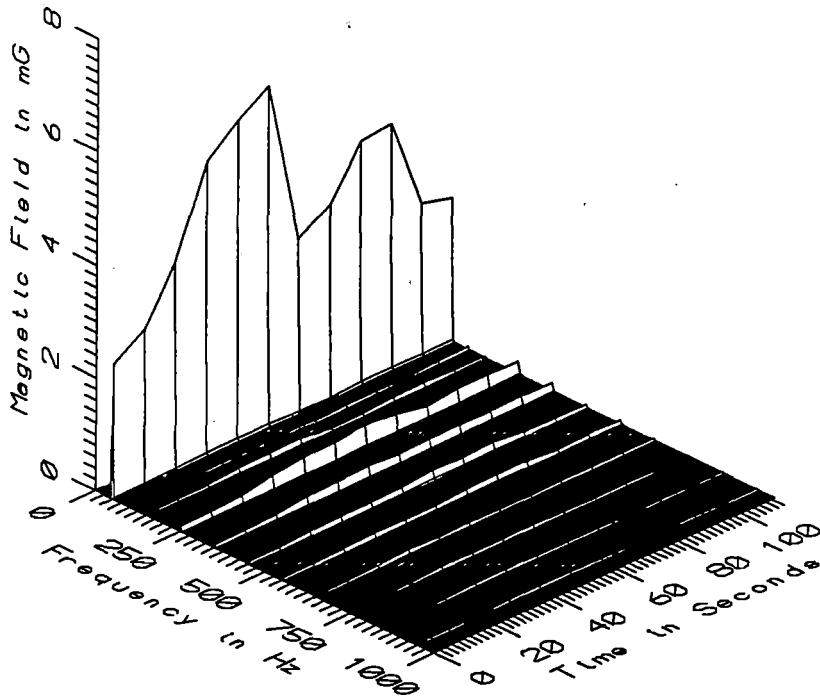

TGV027 - REFERENCE PROBE - 15m FROM STAFF AT CHAILLOT AUTO-TRANSFORMER

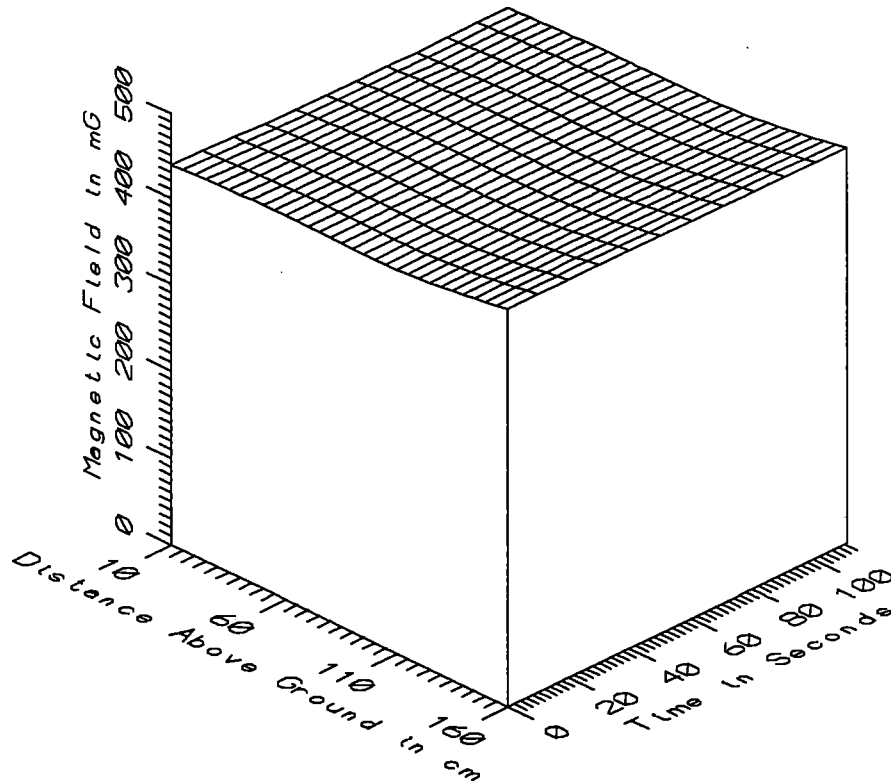

TGV027 - CHAILLOT AUTO-TRANSFORMER, 121km MARKER - STATIC

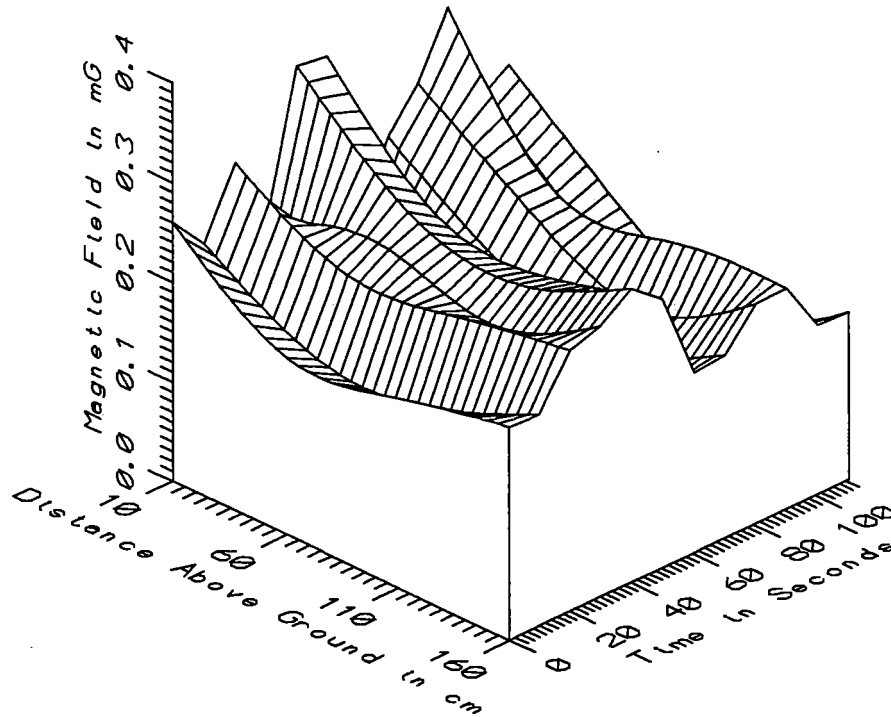

TGV027 - CHAILLOT AUTO-TRANSFORMER, 121km MARKER - LOW FREQ, 5-45Hz

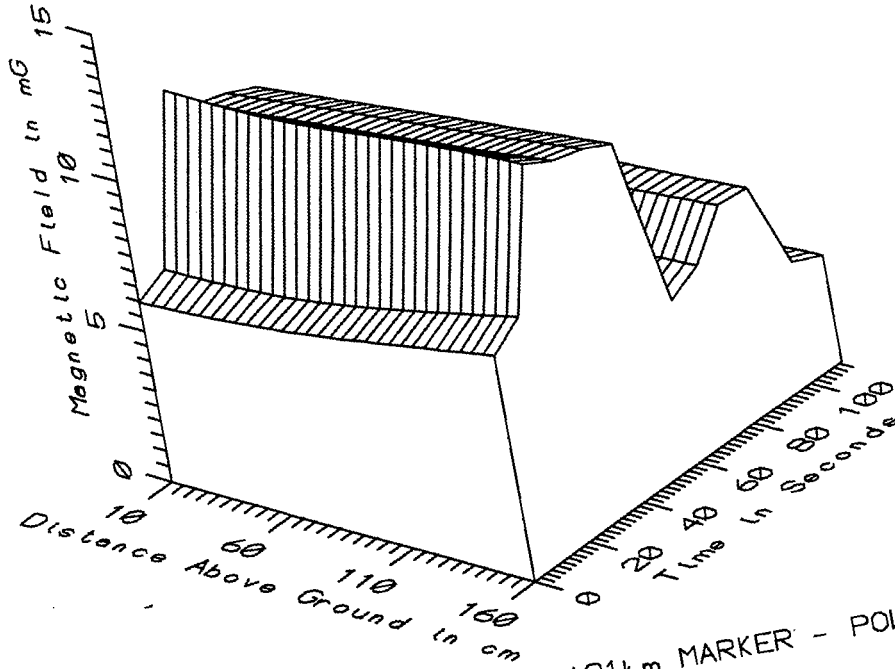

TGV027 - CHAILLOT AUTO-TRANSFORMER, 121km MARKER - POWER FREQ, 50-60Hz

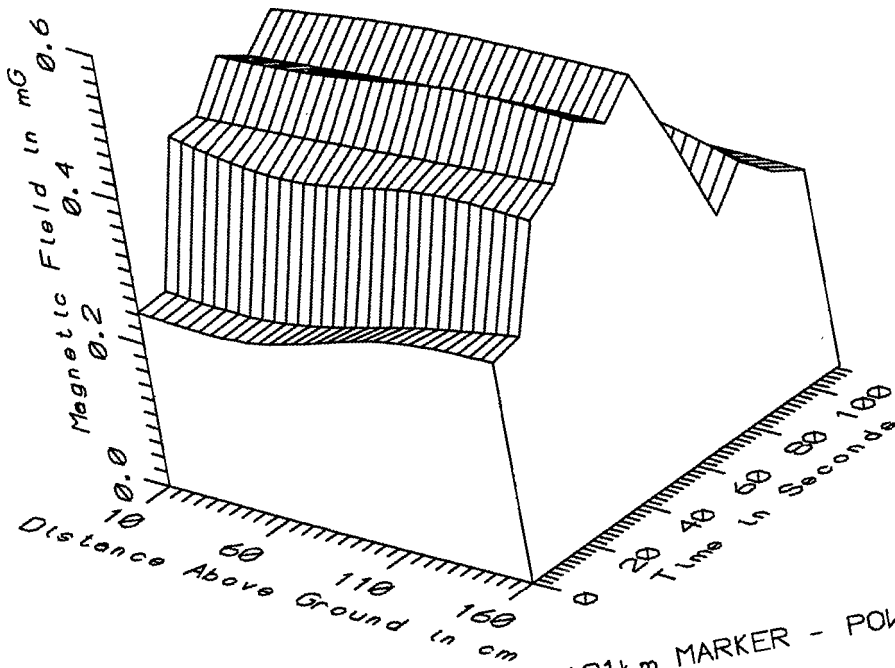

TGV027 - CHAILLOT AUTO-TRANSFORMER, 121km MARKER - POWER HARM, 65-300Hz

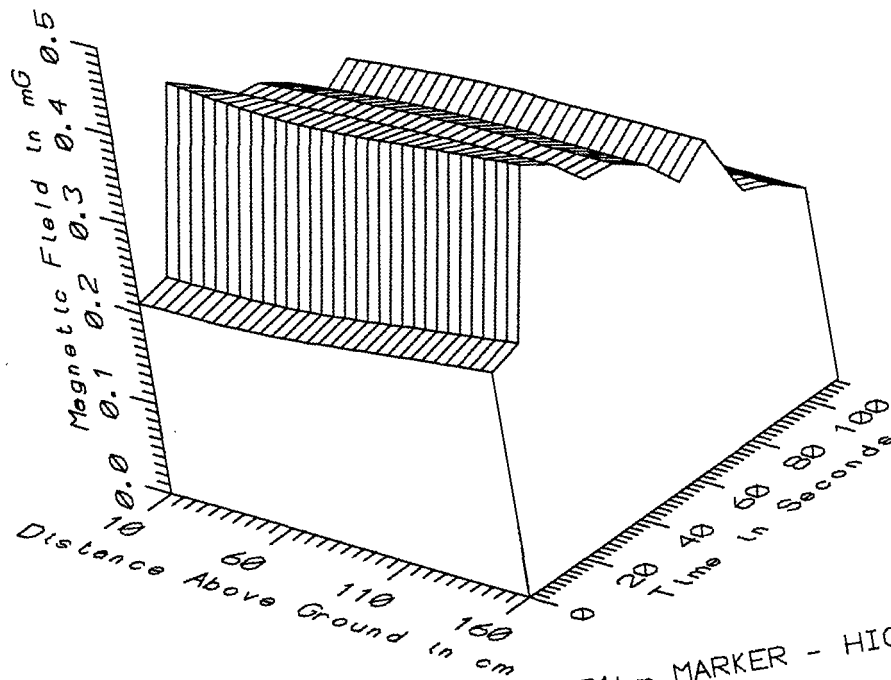

TGV027 - CHAILLOT AUTO-TRANSFORMER, 121km MARKER - HIGH FREQ, 305-2560Hz

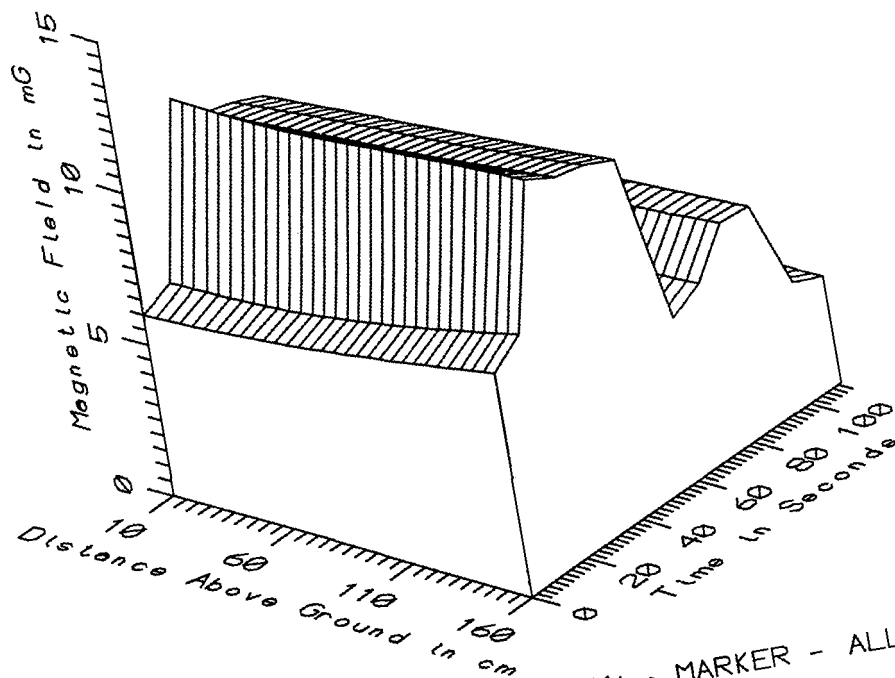

TGV027 - CHAILLOT AUTO-TRANSFORMER, 121km MARKER - ALL FREQ, 5-2560Hz



TGV027 - CHAILLOT AUTO-TRANSFORMER				TOTAL OF 12 SAMPLES		
FREQUENCY BAND	HEIGHT ABOVE GROUND (cm)	MINIMUM MAGNETIC FIELD (mG)	MAXIMUM MAGNETIC FIELD (mG)	AVERAGE MAGNETIC FIELD (mG)	STANDARD DEVIATION (mG)	COEFFICIENT OF VARIATION (%)
STATIC	10	436.81	438.55	437.78	0.52	0.12
	60	442.42	443.05	442.78	0.17	0.04
	110	441.71	442.22	441.86	0.16	0.04
	160	457.34	458.56	458.09	0.40	0.09
5-45Hz LOW FREQ	10	0.16	0.36	0.27	0.06	22.64
	60	0.16	0.27	0.20	0.04	19.20
	110	0.11	0.25	0.18	0.05	27.44
	160	0.17	0.30	0.22	0.04	19.48
50-60Hz PWR FREQ	10	3.12	11.79	7.03	2.93	41.66
	60	3.28	11.81	7.30	2.97	40.73
	110	3.38	12.24	7.62	3.07	40.33
	160	3.52	12.57	8.02	3.18	39.59
65-300Hz PWR HARM	10	0.24	0.50	0.35	0.11	29.71
	60	0.25	0.53	0.37	0.11	29.45
	110	0.27	0.54	0.39	0.10	25.86
	160	0.28	0.55	0.40	0.10	25.65
305-2560Hz HIGH FREQ	10	0.20	0.42	0.30	0.08	25.61
	60	0.21	0.41	0.30	0.08	24.71
	110	0.21	0.42	0.31	0.07	23.98
	160	0.21	0.44	0.32	0.07	23.52
5-2560Hz ALL FREQ	10	3.15	11.81	7.05	2.92	41.49
	60	3.30	11.83	7.32	2.97	40.59
	110	3.40	12.26	7.64	3.07	40.20
	160	3.54	12.58	8.04	3.17	39.46

APPENDIX AC

DATASET TGV028  
AT CHAILLOT AUTOTRANSFORMER

Measurement Setup Code:           Staff: 27           Reference: 28  
  Drawing: A-6

Vehicle Status:                    Single train set passed 320 seconds  
  into the record

Measurement Date:                 September 9, 1992

Measurement Time:                 Start:     10:26:43  
  End:       10:33:30

Number of Samples:                36

Programmed Sample Interval:      10 sec

Actual Sample Interval:           11.6 sec

Frequency Spectrum Parameters

<u>Probe Type:</u>	<u>Wideband</u>	<u>Static</u>
Maximum Frequency (Hz)	2560	64
Minimum Frequency (Hz)	5	0
Spectral Bandwidth (Hz)	5	1

Missing or Suspect Data:         None

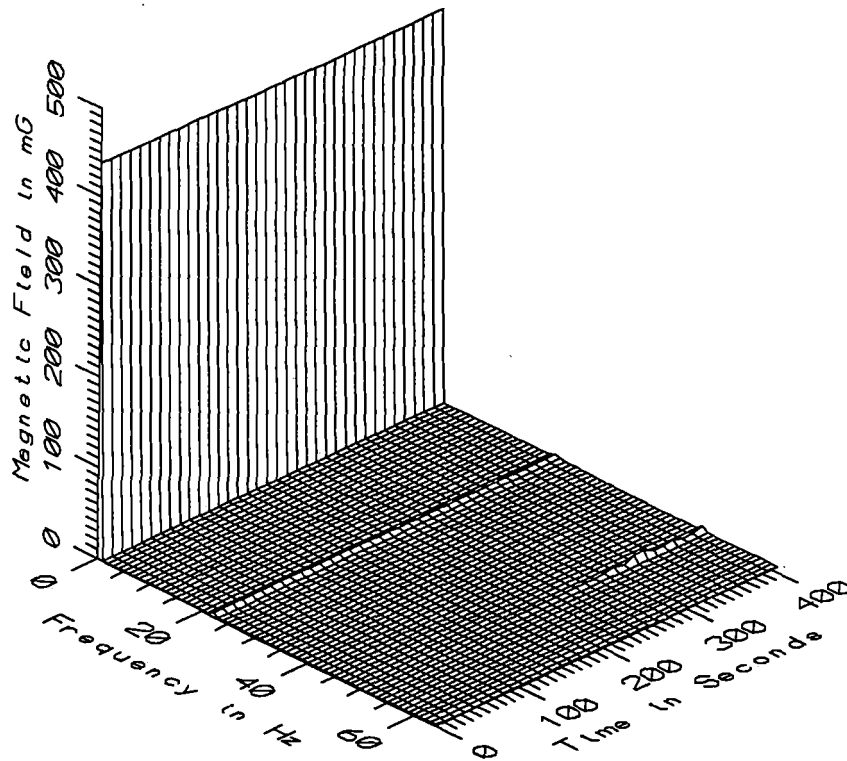

TGV028 - 10cm ABOVE GROUND AT CHAILLOT AUTO-TRANSFORMER, 121km MARKER

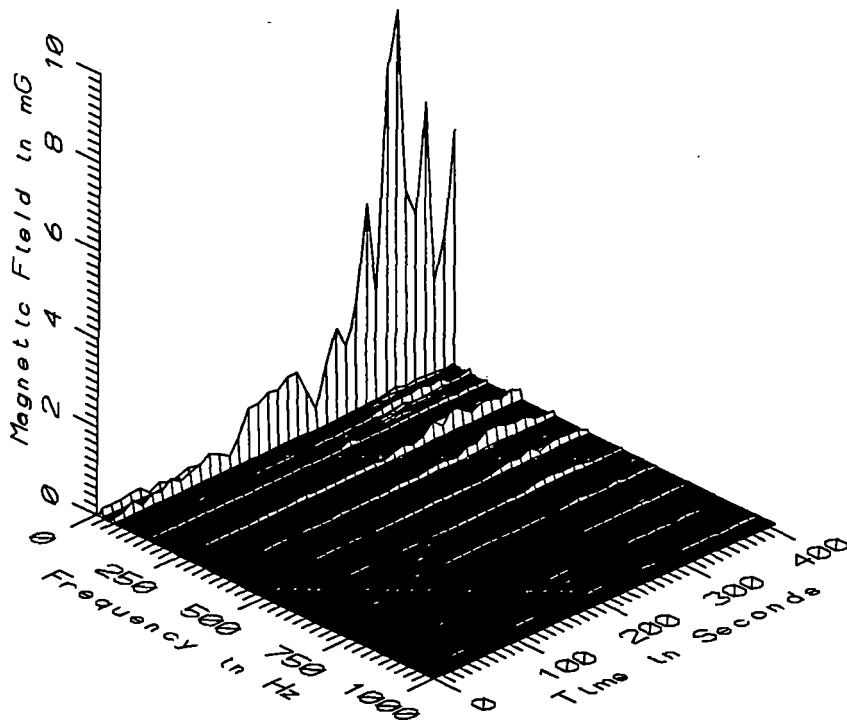

TGV028 - 10cm ABOVE GROUND AT CHAILLOT AUTO-TRANSFORMER, 121km MARKER

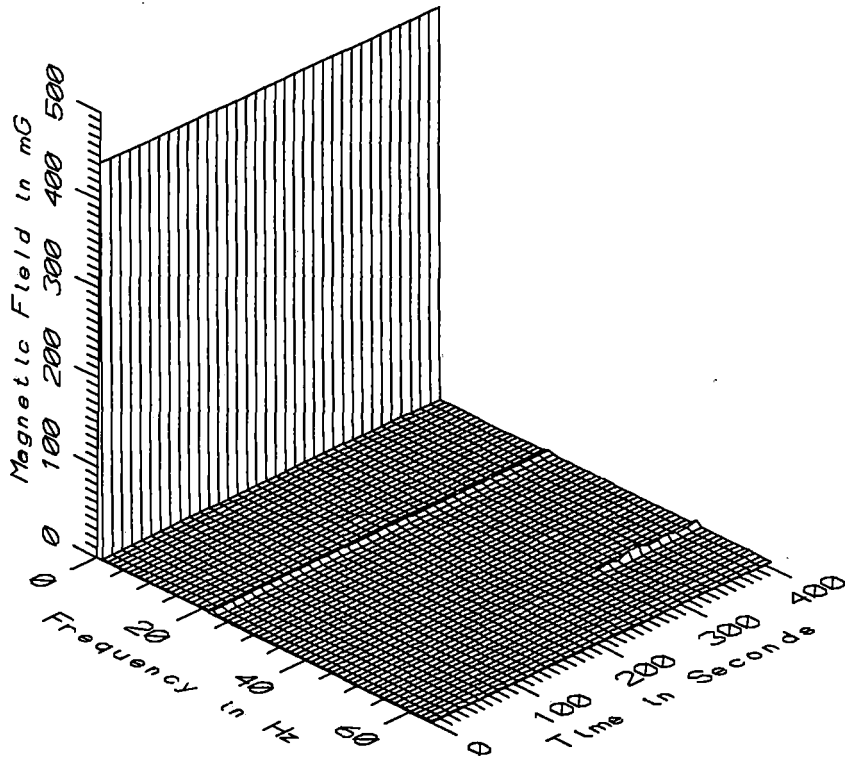

TGV028 - 60cm ABOVE GROUND AT CHAILLOT AUTO-TRANSFORMER, 121km MARKER

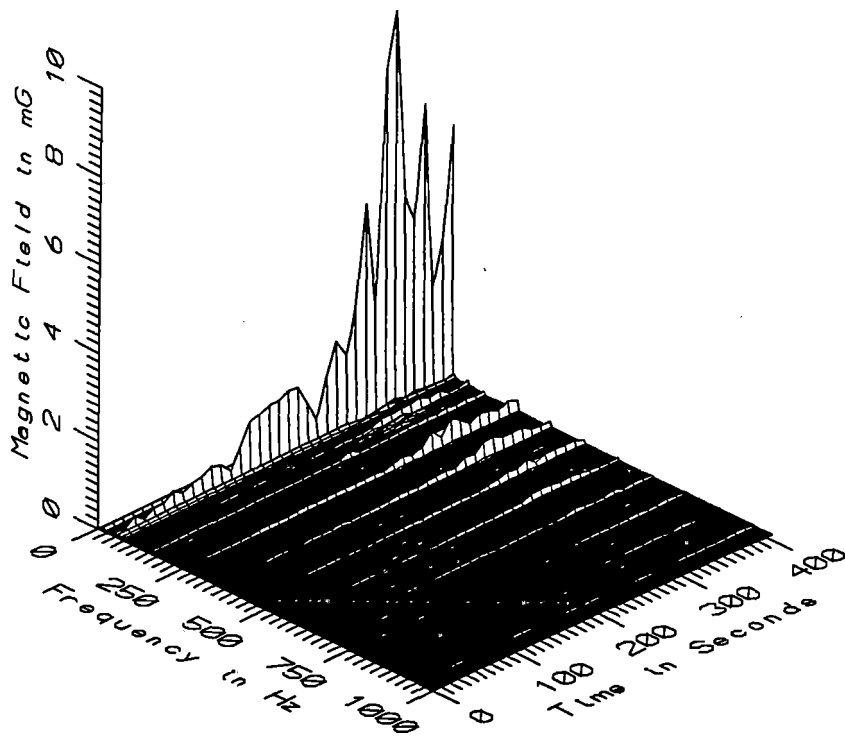

TGV028 - 60cm ABOVE GROUND AT CHAILLOT AUTO-TRANSFORMER, 121km MARKER

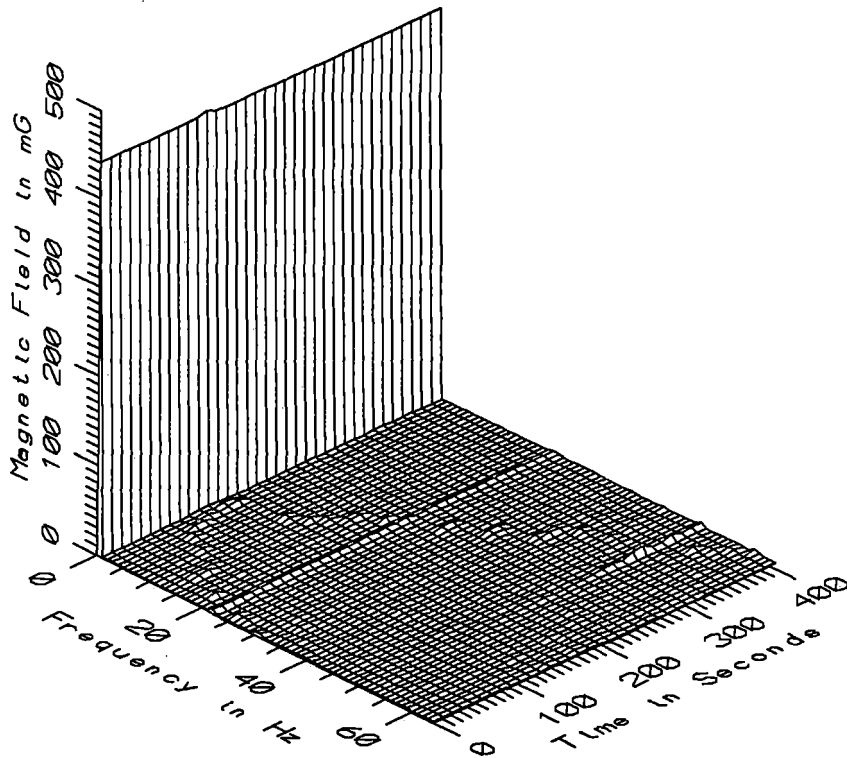

TGV028 - 110cm ABOVE GROUND AT CHAILLOT AUTO-TRANSFORMER, 121km MARKER

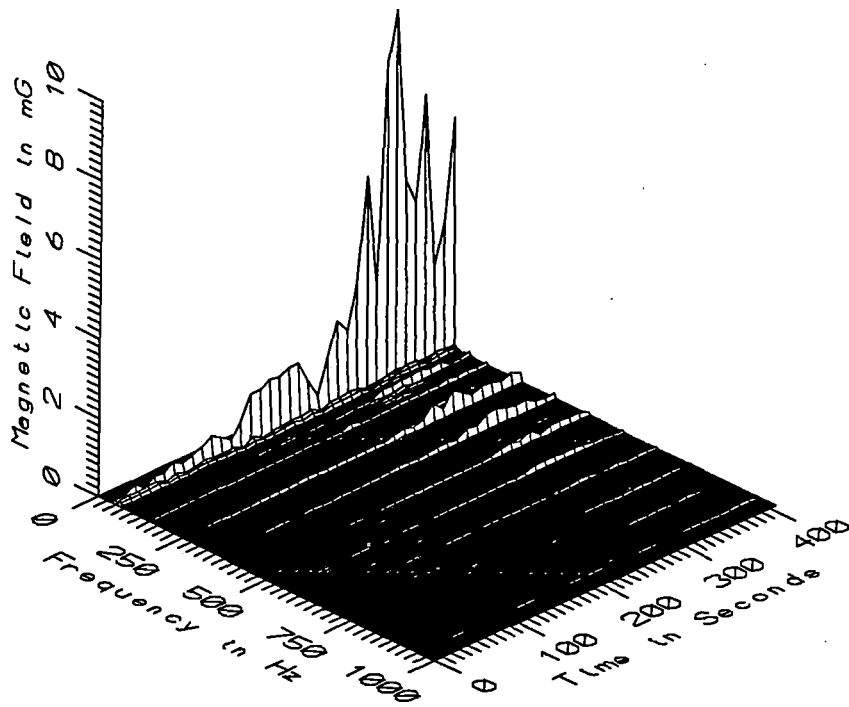

TGV028 - 110cm ABOVE GROUND AT CHAILLOT AUTO-TRANSFORMER, 121km MARKER

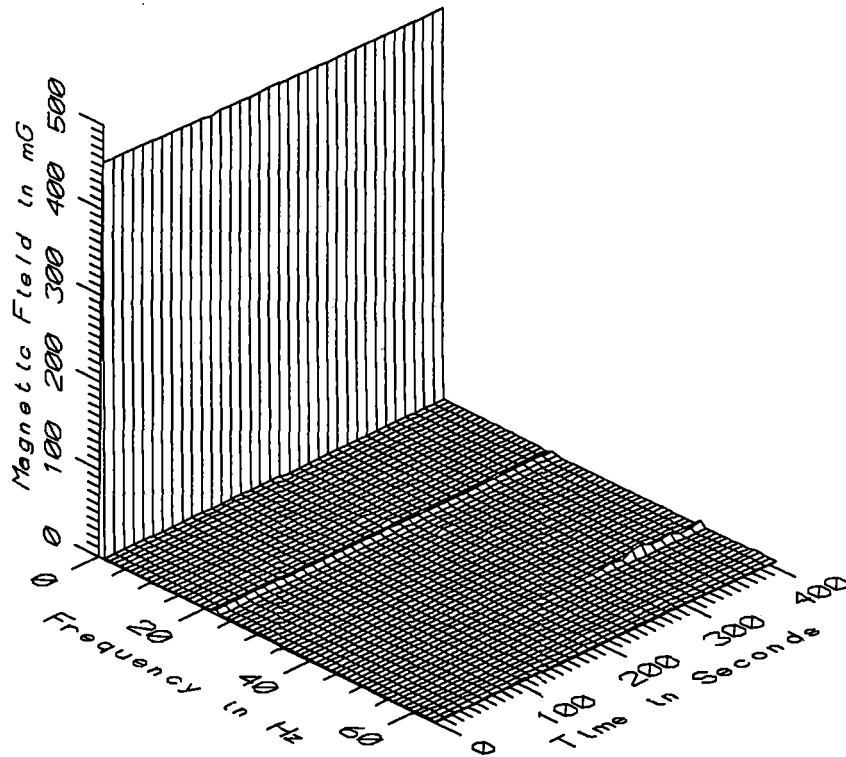

TGV028 - 160cm ABOVE GROUND AT CHAILLOT AUTO-TRANSFORMER, 121km MARKER

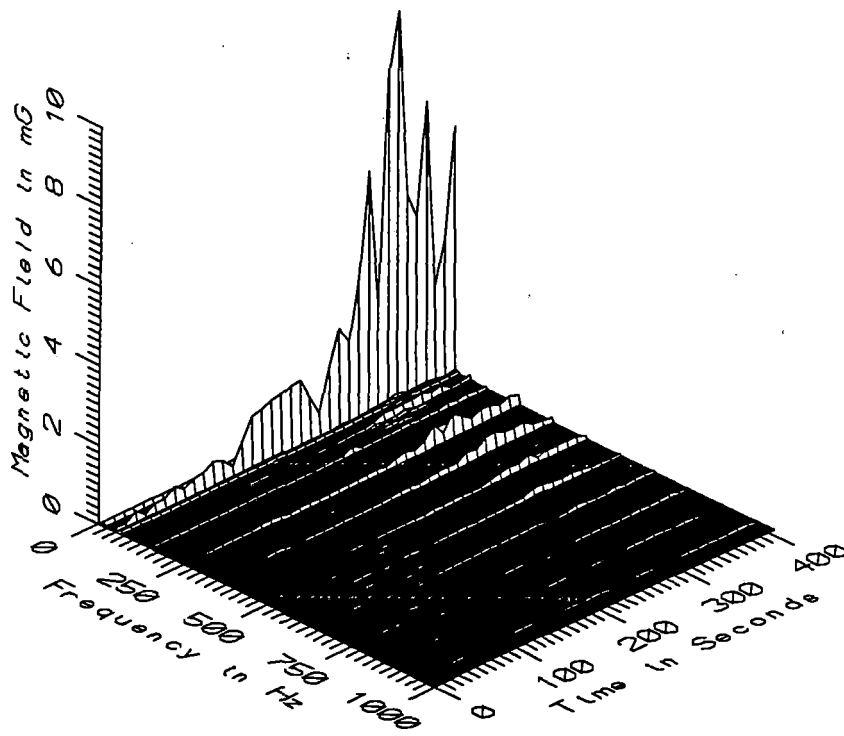

TGV028 - 160cm ABOVE GROUND AT CHAILLOT AUTO-TRANSFORMER, 121km MARKER

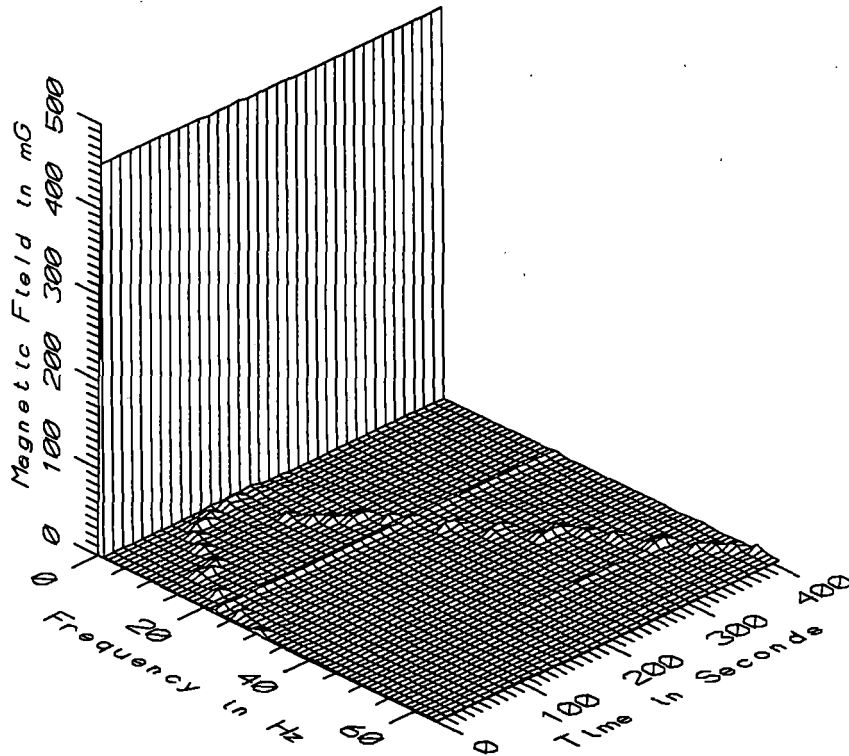

TGV028 - REFERENCE PROBE - 15m FROM STAFF AT CHAILLOT AUTO-TRANSFORMER

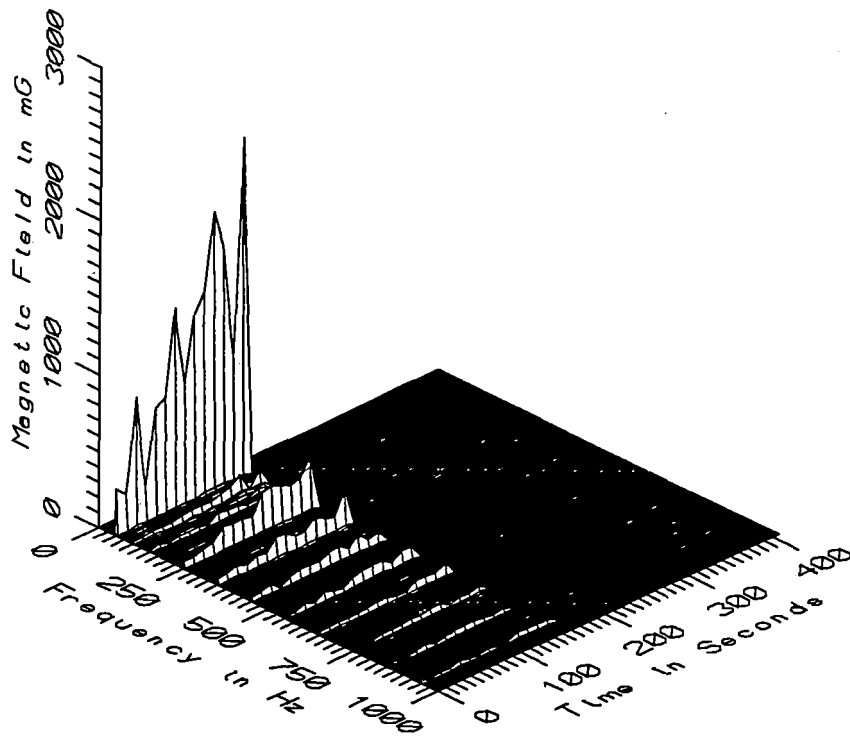

TGV028 - REFERENCE PROBE - 15m FROM STAFF AT CHAILLOT AUTO-TRANSFORMER

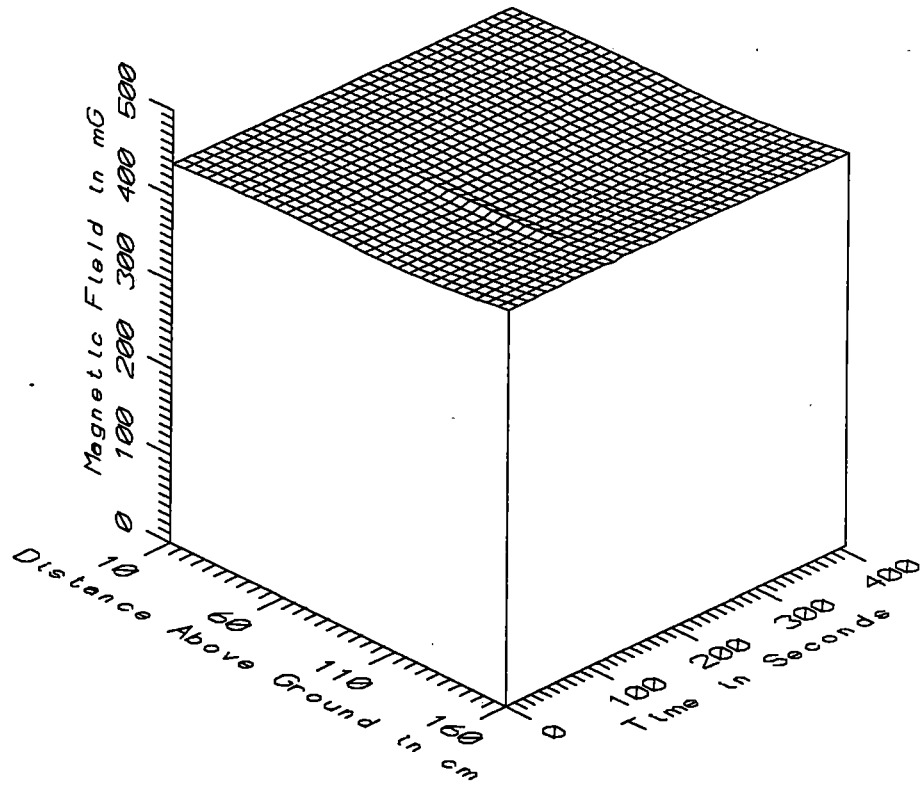

TGV028 - CHAILLOT AUTO-TRANSFORMER, 121km MARKER - STATIC

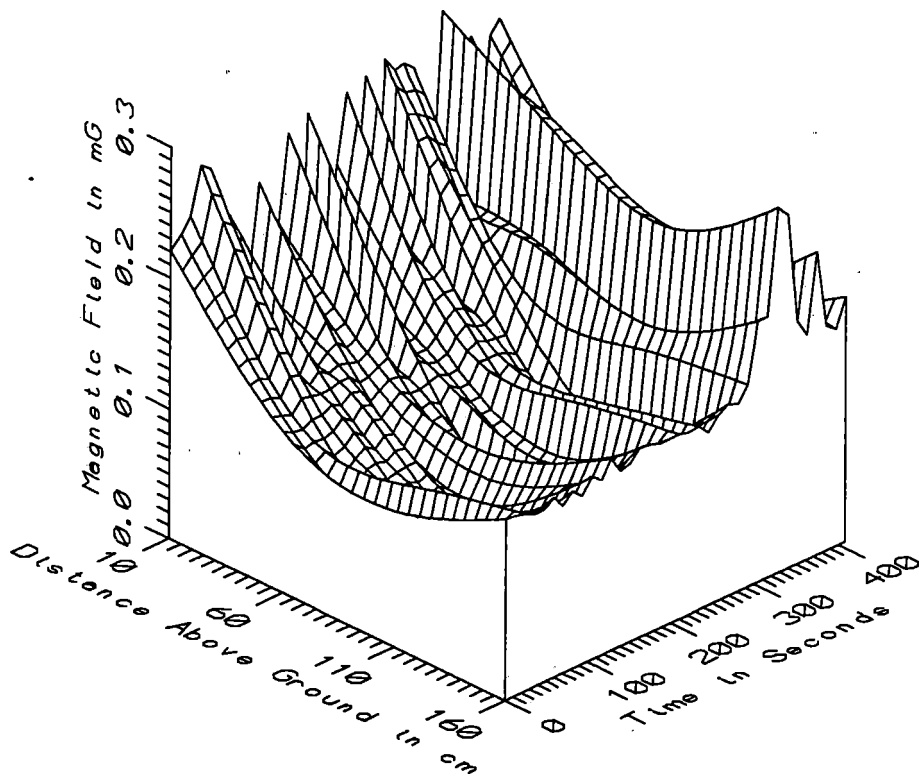

TGV028 - CHAILLOT AUTO-TRANSFORMER, 121km MARKER - LOW FREQ, 5-45Hz



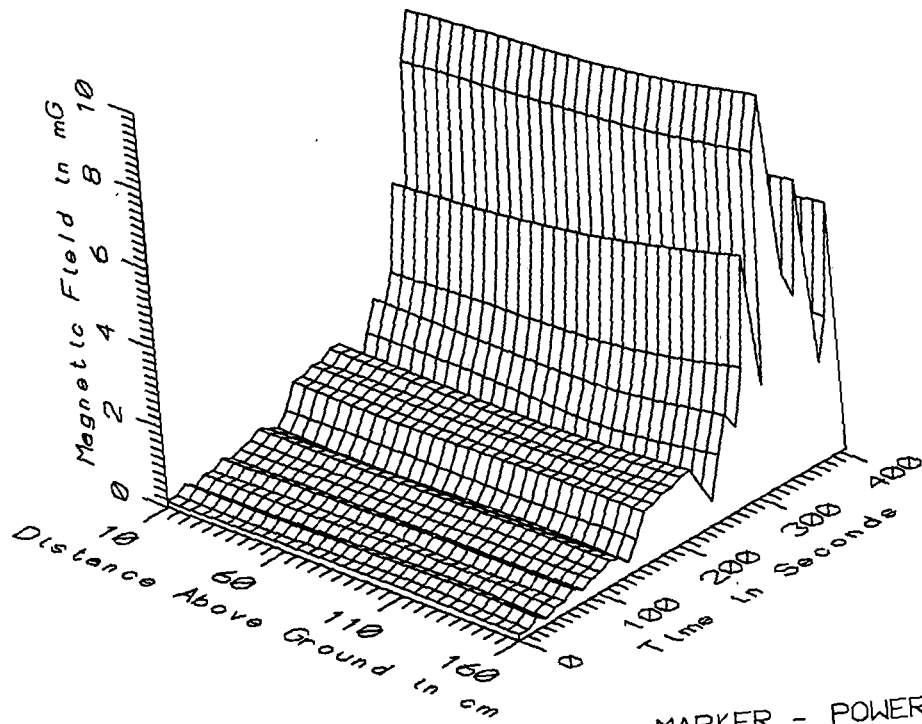

TGV028 - CHAILLOT AUTO-TRANSFORMER, 121km MARKER - POWER FREQ, 50-60Hz

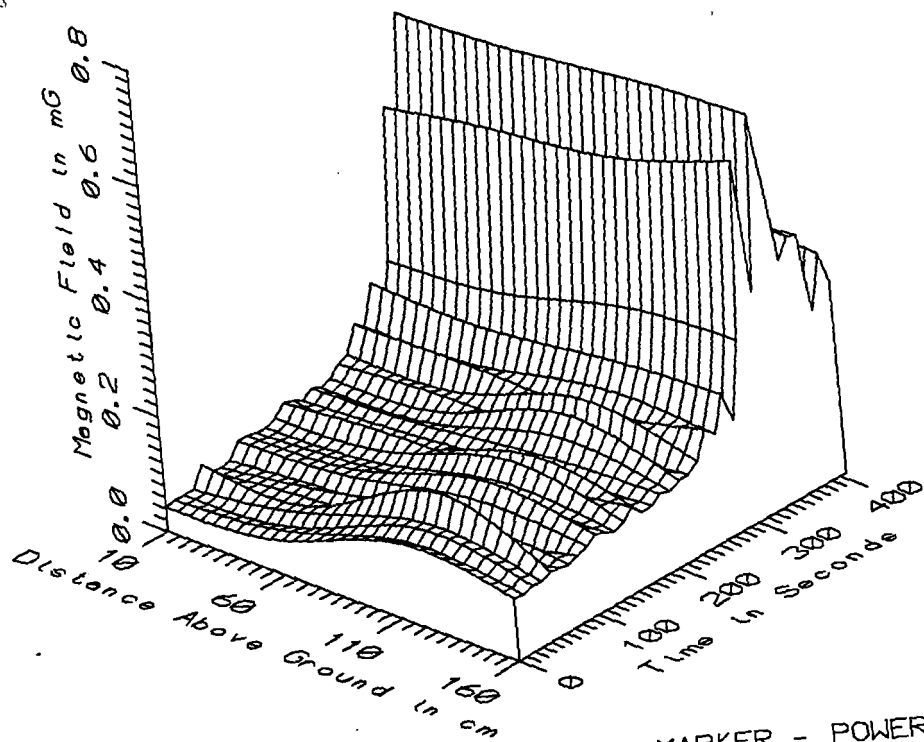

TGV028 - CHAILLOT AUTO-TRANSFORMER, 121km MARKER - POWER HARM, 65-300Hz

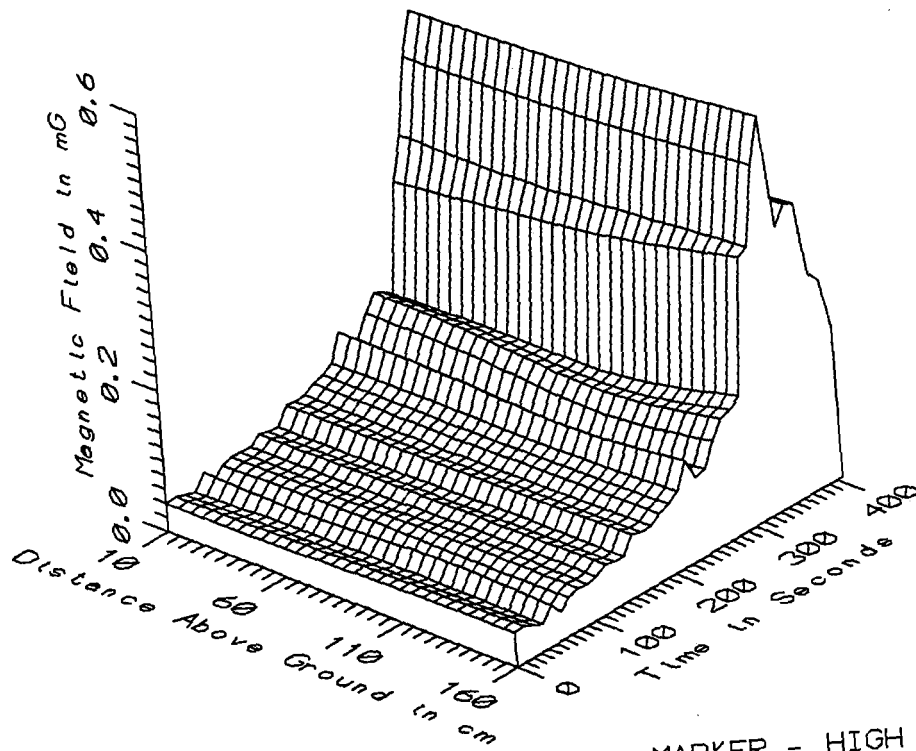

TGV028 - CHAILLOT AUTO-TRANSFORMER, 121km MARKER - HIGH FREQ, 305-2560Hz

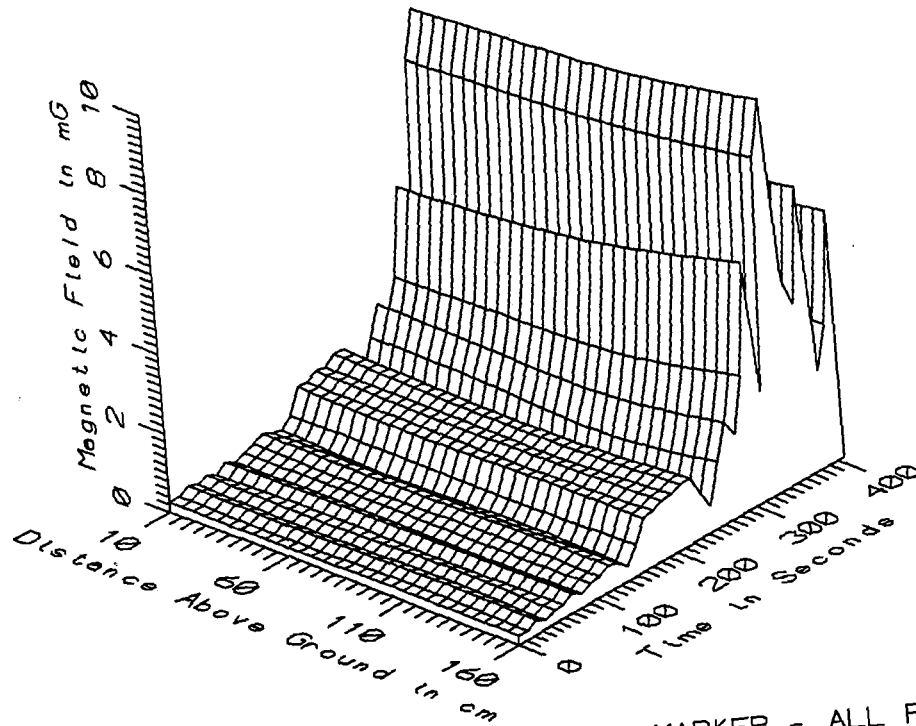

TGV028 - CHAILLOT AUTO-TRANSFORMER, 121km MARKER - ALL FREQ, 5-2560Hz

121 km MARKER

TGV028 - CHAILLOT AUTO-TRANSFORMER				TOTAL OF 36 SAMPLES		
FREQUENCY BAND	HEIGHT ABOVE GROUND (cm)	MINIMUM MAGNETIC FIELD (mG)	MAXIMUM MAGNETIC FIELD (mG)	AVERAGE MAGNETIC FIELD (mG)	STANDARD DEVIATION (mG)	COEFFICIENT OF VARIATION (%)
STATIC	10	437.48	438.46	437.86	0.25	0.06
	60	442.17	443.02	442.54	0.21	0.05
	110	440.70	444.98	441.39	0.67	0.15
	160	453.44	456.12	455.39	0.47	0.10
5-45Hz LOW FREQ	10	0.11	0.31	0.23	0.06	25.19
	60	0.12	0.26	0.14	0.03	24.04
	110	0.06	0.23	0.11	0.04	38.74
	160	0.13	0.28	0.16	0.04	23.32
50-60Hz PWR FREQ	10	0.11	8.70	1.95	2.20	112.59
	60	0.14	8.95	2.01	2.28	113.64
	110	0.18	9.25	2.08	2.36	113.57
	160	0.14	9.79	2.26	2.53	112.11
65-300Hz PWR HARM	10	0.04	0.64	0.18	0.16	86.29
	60	0.06	0.65	0.20	0.16	79.80
	110	0.08	0.68	0.24	0.15	63.33
	160	0.11	0.69	0.24	0.16	67.67
305-2560Hz HIGH FREQ	10	0.03	0.53	0.16	0.14	88.42
	60	0.04	0.54	0.16	0.14	88.78
	110	0.04	0.55	0.16	0.14	88.72
	160	0.04	0.56	0.17	0.15	86.70
5-2560Hz ALL FREQ	10	0.27	8.73	2.01	2.18	108.85
	60	0.20	8.98	2.04	2.28	111.80
	110	0.25	9.29	2.12	2.36	111.75
	160	0.23	9.83	2.30	2.53	109.92

**APPENDIX AD**

**DATASET TGV029  
OVERPASS**

Measurement Setup Code:      Staff: 29      Reference: 30  
   Drawing: A-7

Vehicle Status:              Double train set passed 223 seconds  
   into the record

Measurement Date:              September 9, 1992

Measurement Time:              Start:      10:58:02  
   End:        11:03:10

Number of Samples:              33

Programmed Sample Interval:      5 sec

Actual Sample Interval:        9.6 sec

**Frequency Spectrum Parameters**

<u>Probe Type:</u>	<u>Wideband</u>	<u>Static</u>
Maximum Frequency (Hz)	2560	64
Minimum Frequency (Hz)	5	0
Spectral Bandwidth (Hz)	5	1

Missing or Suspect Data:      None

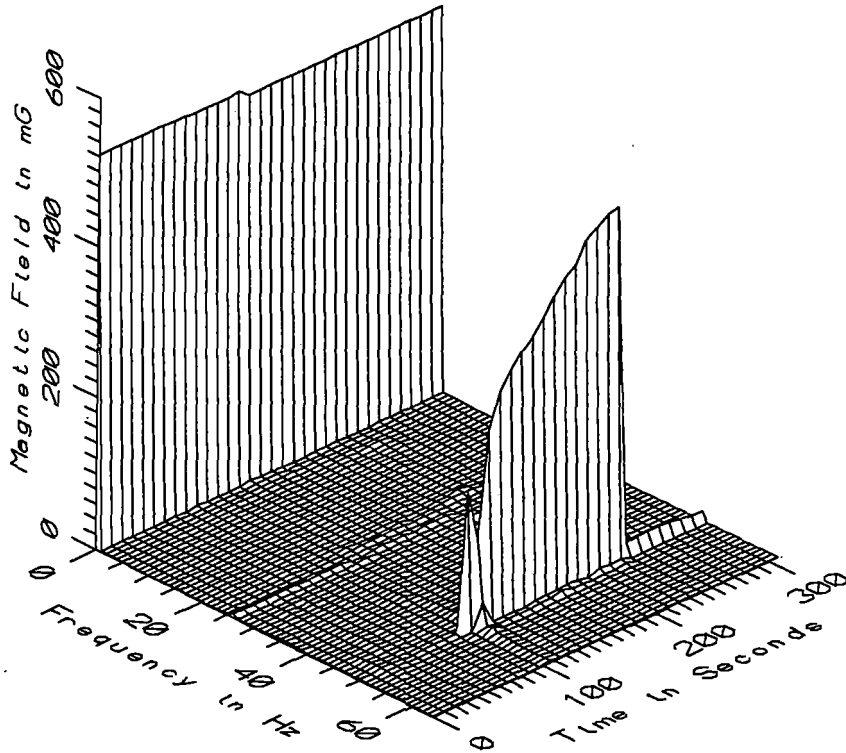

TGV029 - 10cm ABOVE OVERPASS BASE, ABOVE PARIS BOUND LINE. 120k m MARKER

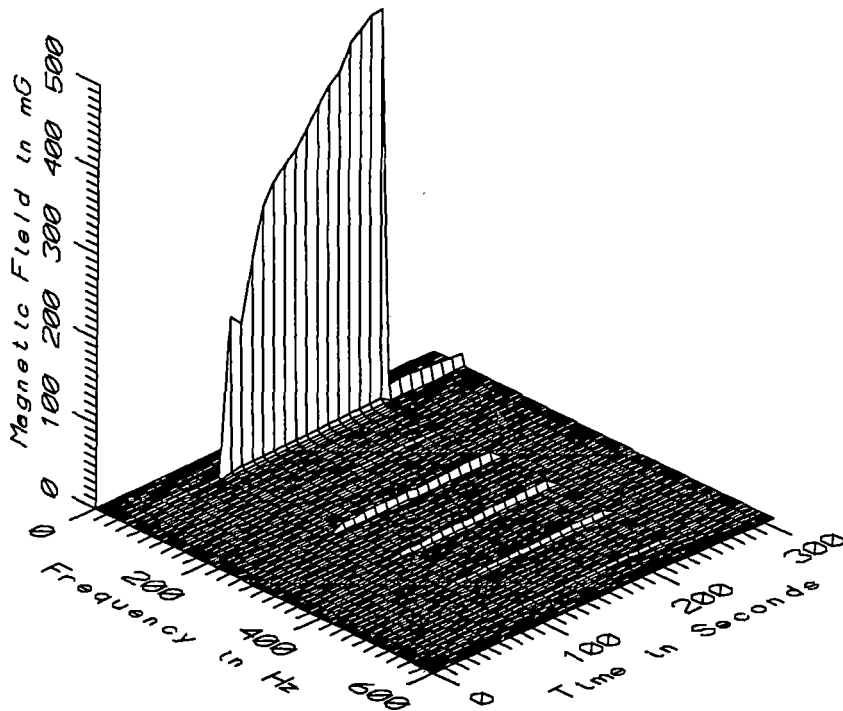

TGV029 - 10cm ABOVE OVERPASS BASE, ABOVE PARIS BOUND LINE. 120k m MARKER

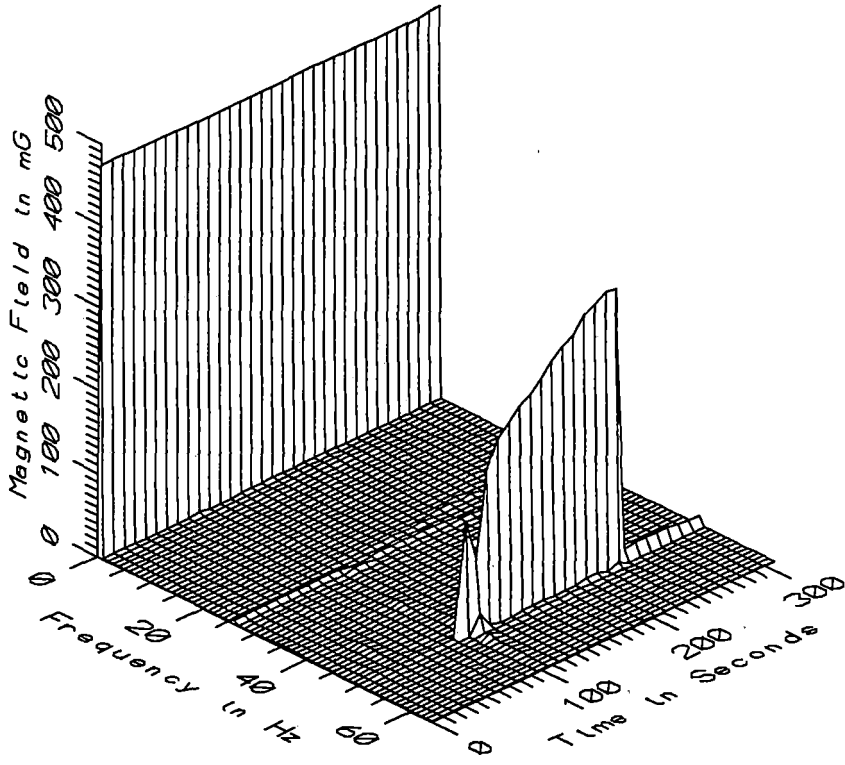

TGV029 - 60cm ABOVE OVERPASS BASE, ABOVE PARIS BOUND LINE. 120km MARKER

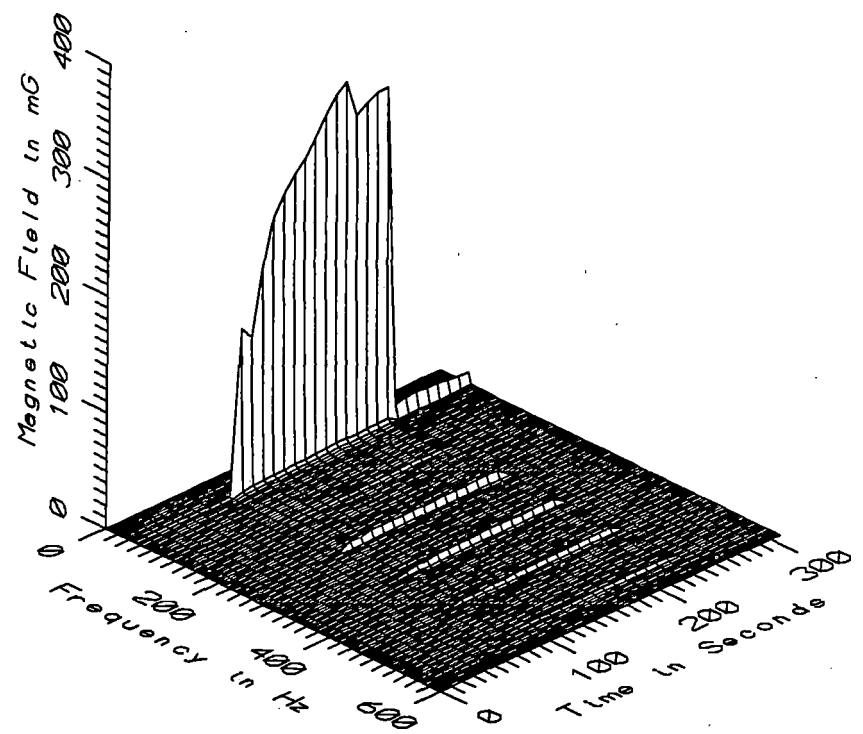

TGV029 - 60cm ABOVE OVERPASS BASE, ABOVE PARIS BOUND LINE. 120km MARKER

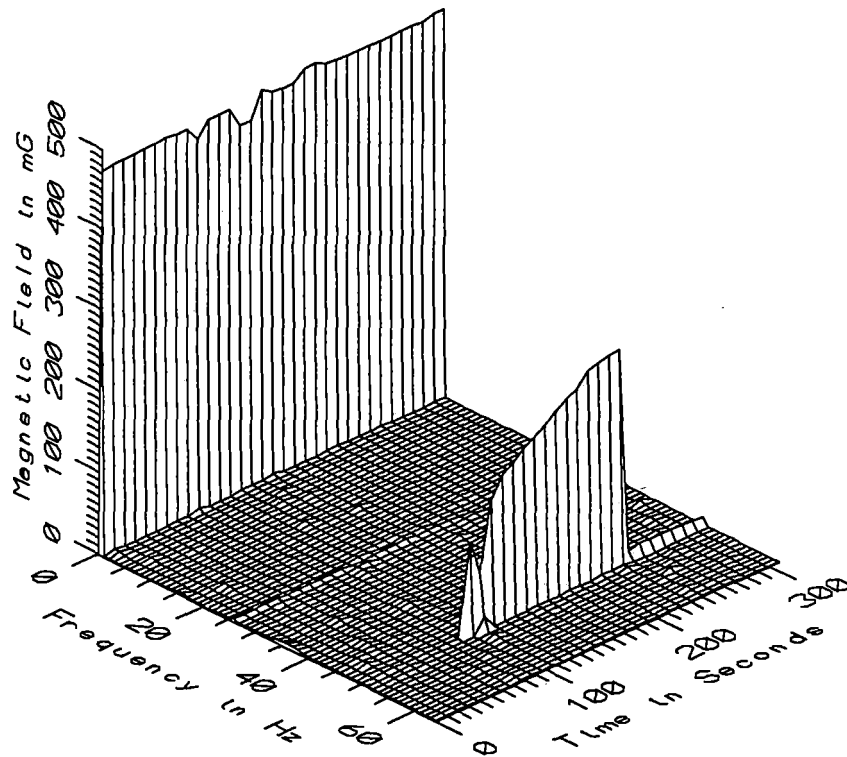

TGV029 - 110cm ABOVE OVERPASS BASE, ABOVE PARIS BOUND LINE. 120k m MARKER

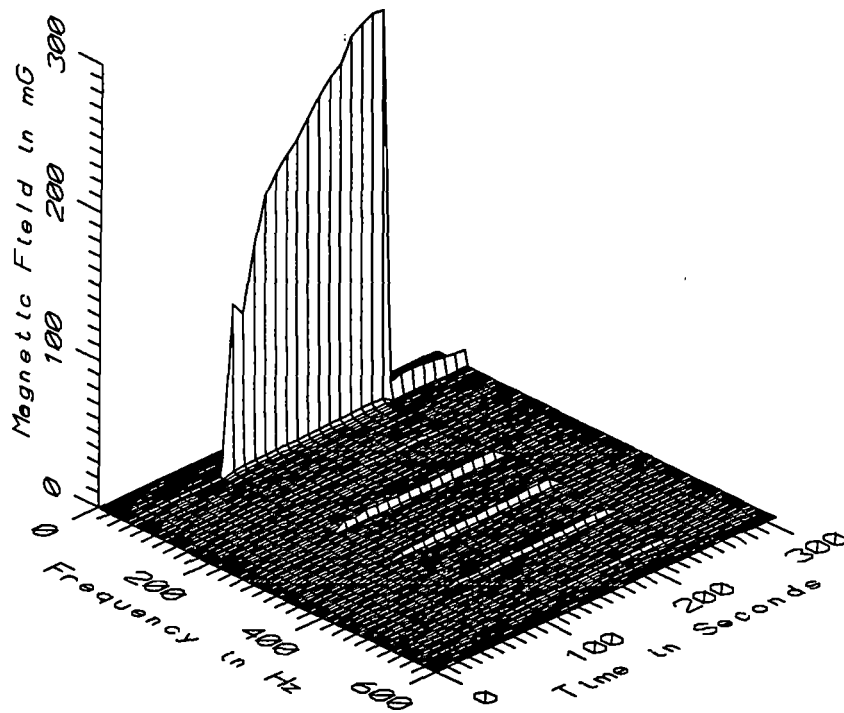

TGV029 - 110cm ABOVE OVERPASS BASE, ABOVE PARIS BOUND LINE. 120k m MARKER

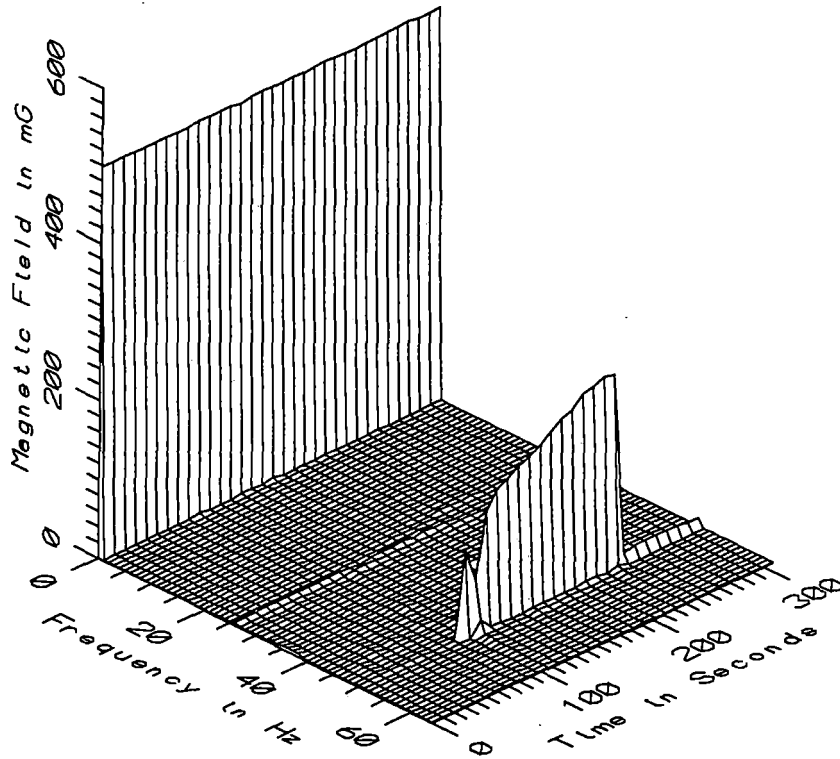

TGV029 - 160cm ABOVE OVERPASS BASE, ABOVE PARIS BOUND LINE. 120k m MARKER

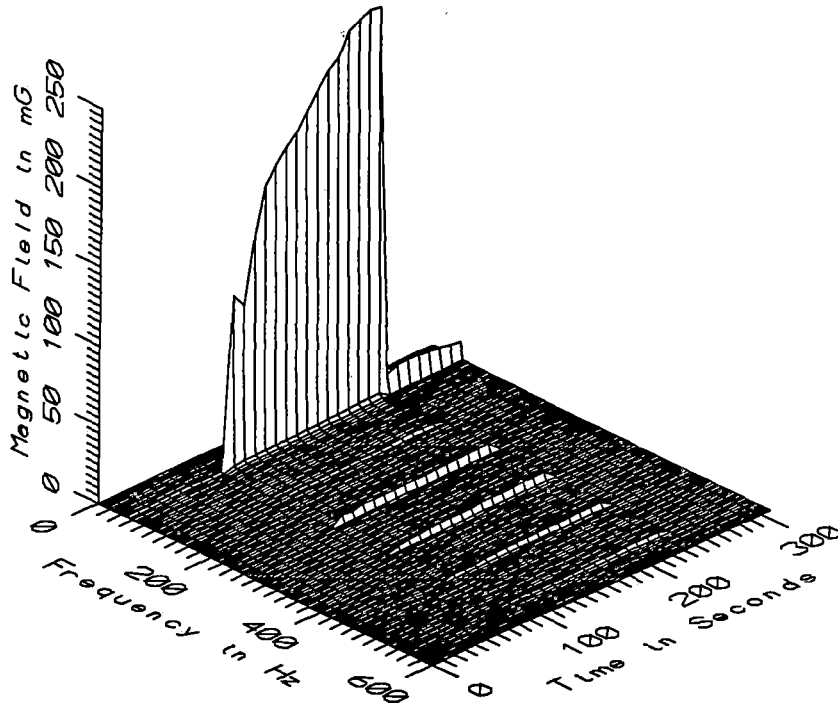

TGV029 - 160cm ABOVE OVERPASS BASE, ABOVE PARIS BOUND LINE. 120k m MARKER



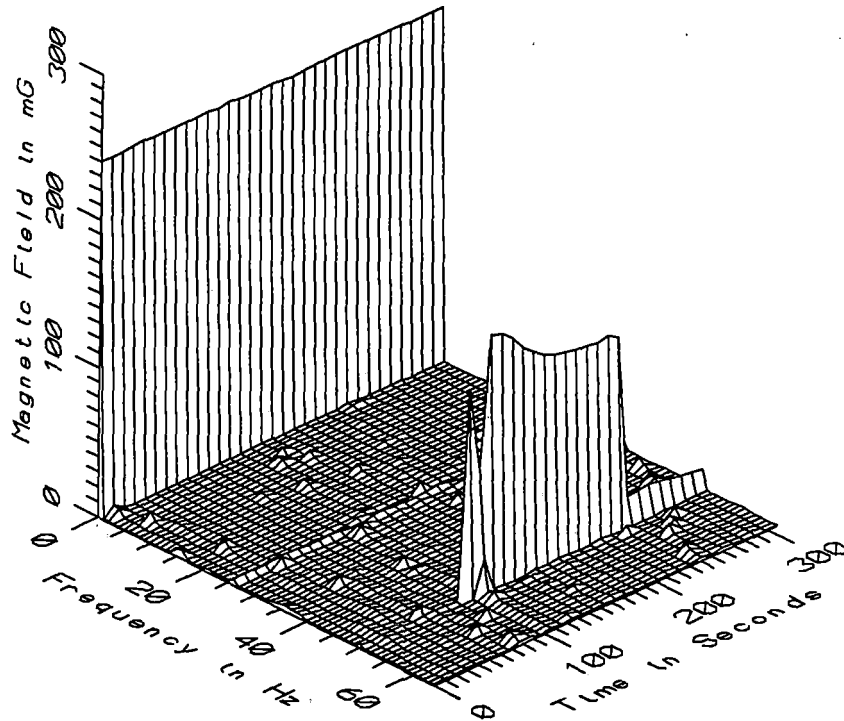

TGV029 - REFERENCE PROBE - AT BASE OF OVERPASS ABOVE PARIS OUTBOUND LINE -

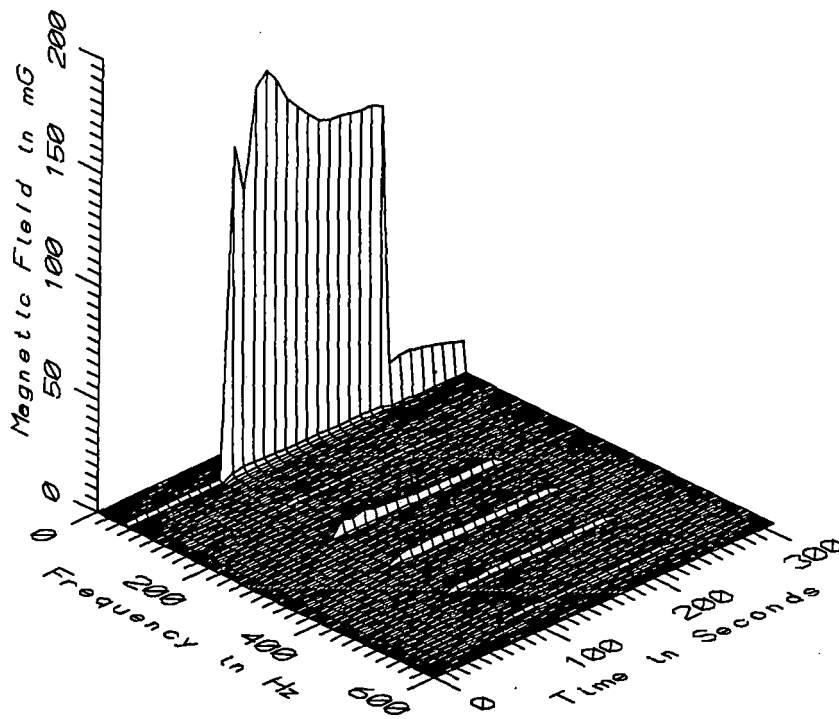

TGV029 - REFERENCE PROBE - AT BASE OF OVERPASS ABOVE PARIS OUTBOUND LINE

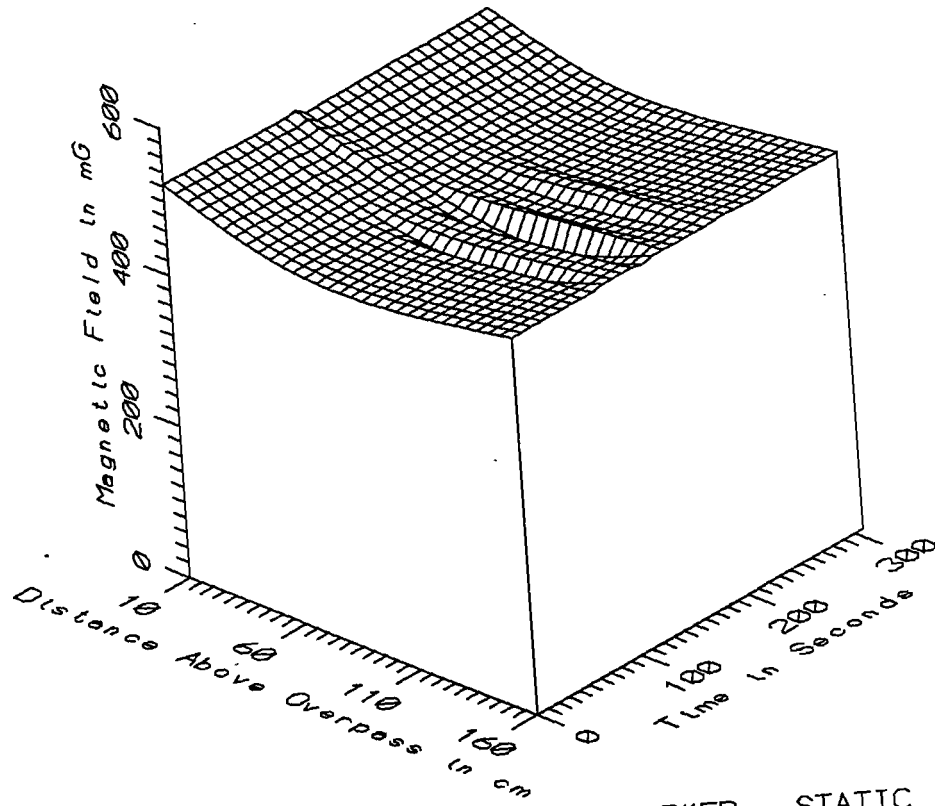

TGV029 - ABOVE PARIS BOUND LINE, 120k m MARKER - STATIC

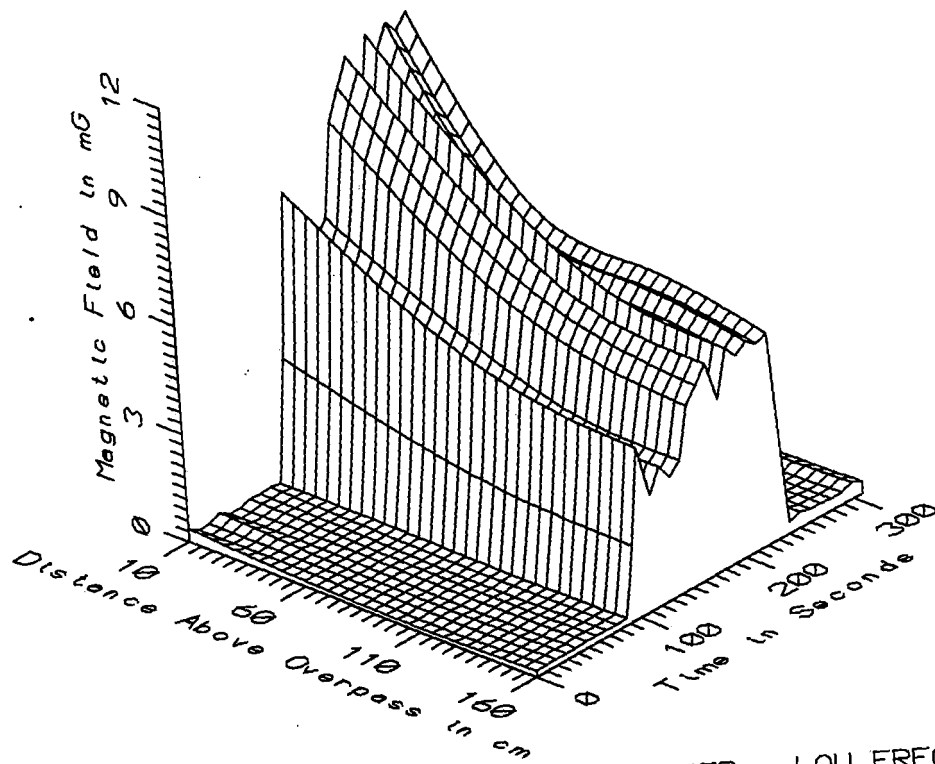

TGV029 - ABOVE PARIS BOUND LINE, 120k m MARKER - LOW FREQ, 5-45Hz

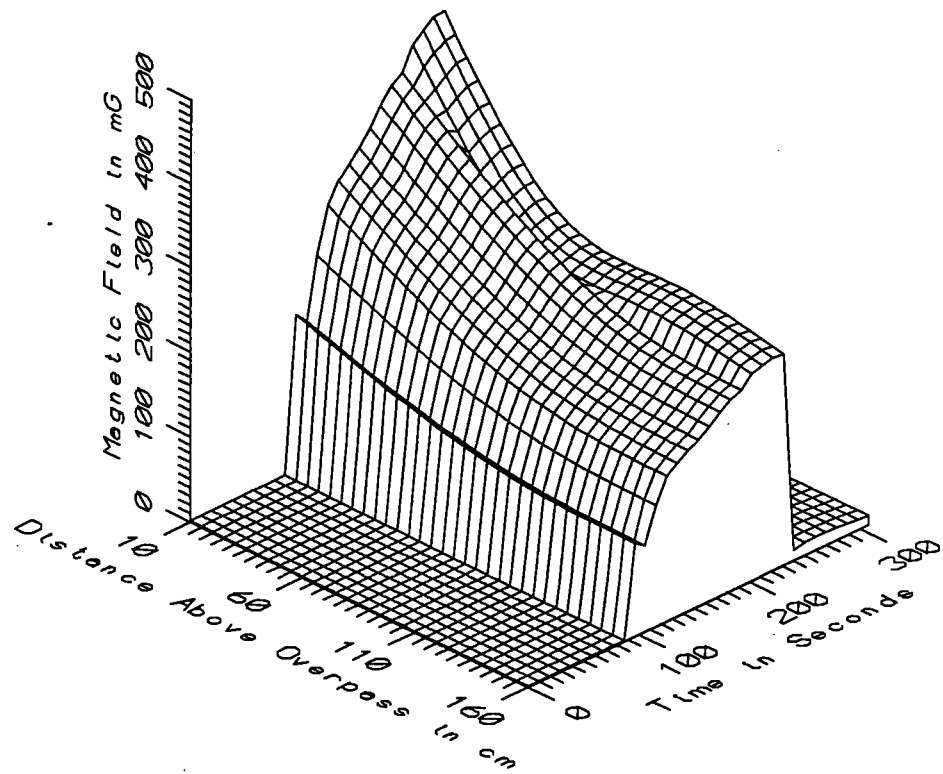

TGV029 - ABOVE PARIS BOUND LINE, 120km MARKER - POWER FREQ, 50-60Hz

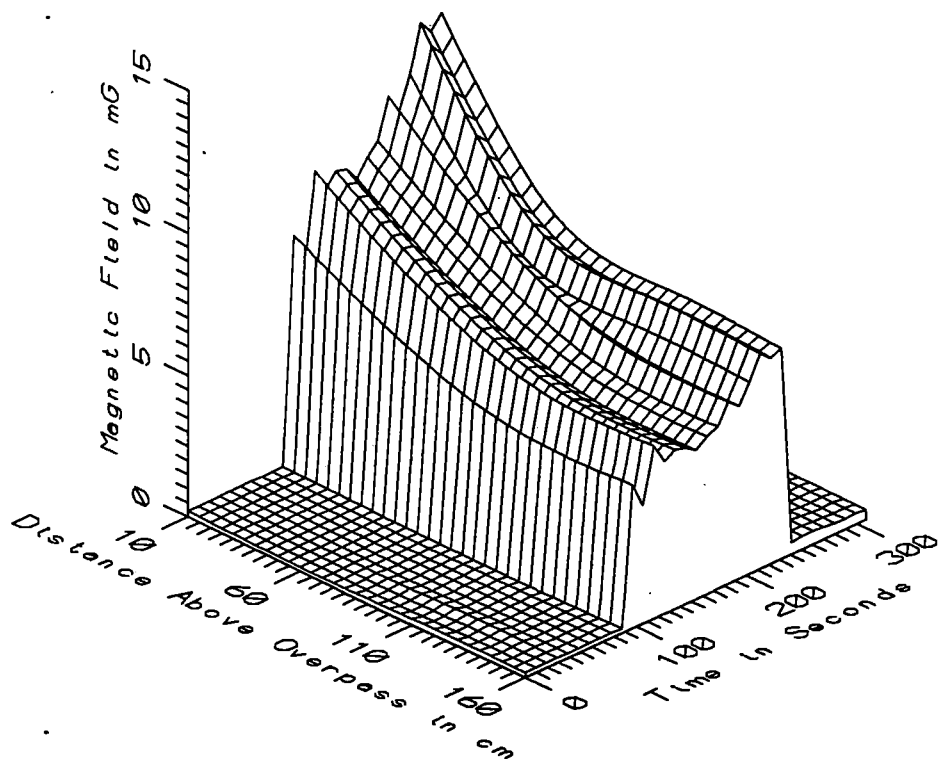

TGV029 - ABOVE PARIS BOUND LINE, 120km MARKER - POWER HARM, 65-300Hz

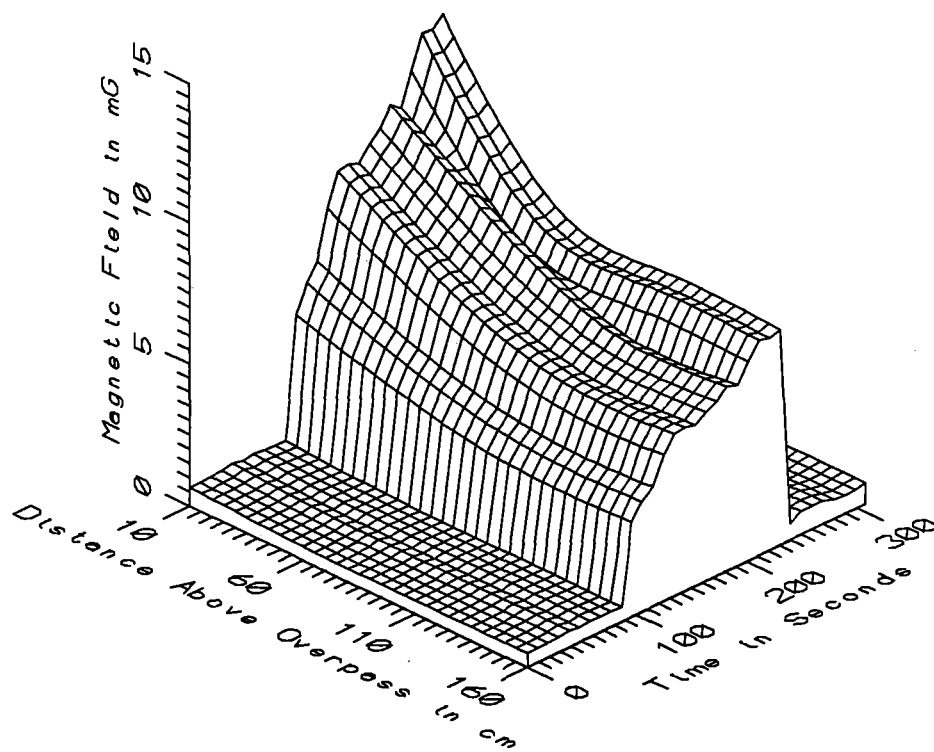

TGV029 - ABOVE PARIS BOUND LINE, 120k m MARKER - HIGH FREQ, 305-2560Hz

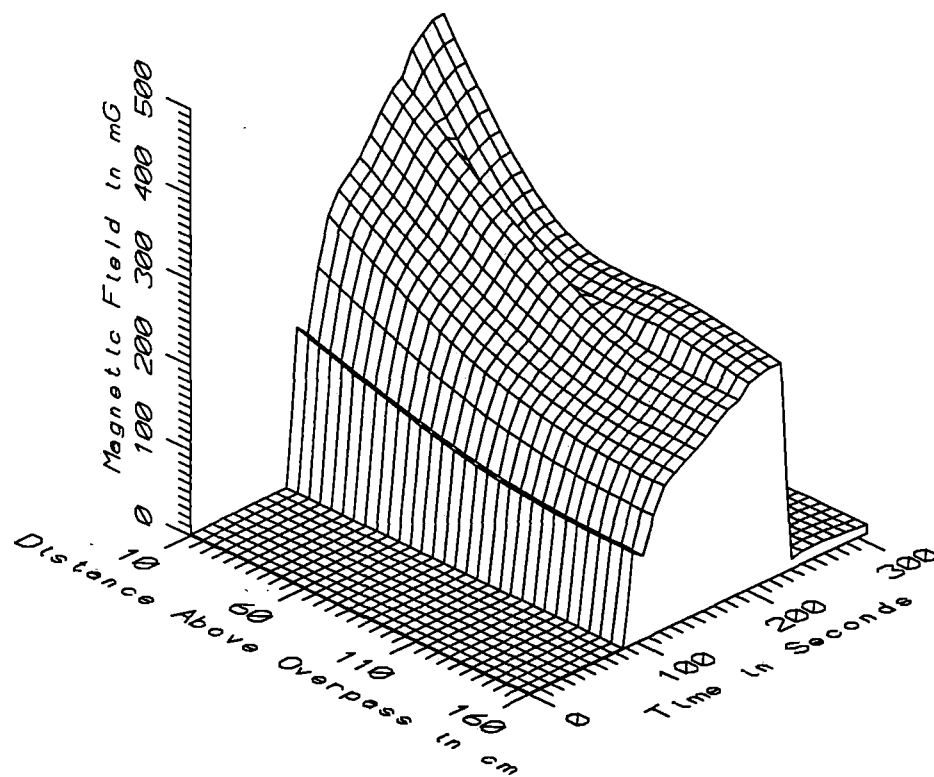

TGV029 - ABOVE PARIS BOUND LINE, 120k m MARKER - ALL FREQ, 5-2560Hz

TGV029 - OVERPASS - ABOVE PARIS BOUND LINE				TOTAL OF 33 SAMPLES		
FREQUENCY BAND	HEIGHT ABOVE GROUND (cm)	MINIMUM MAGNETIC FIELD (mG)	MAXIMUM MAGNETIC FIELD (mG)	AVERAGE MAGNETIC FIELD (mG)	STANDARD DEVIATION (mG)	COEFFICIENT OF VARIATION (%)
STATIC	10	514.32	524.46	518.84	3.58	0.69
	60	473.28	477.11	474.73	0.77	0.16
	110	451.67	487.83	476.38	7.90	1.66
	160	497.59	503.31	500.62	1.79	0.36
5-45Hz LOW FREQ	10	0.14	10.83	4.03	4.41	109.48
	60	0.15	8.05	2.86	3.08	107.50
	110	0.08	6.30	2.38	2.58	108.11
	160	0.18	5.96	2.29	2.38	103.97
50-60Hz PWR FREQ	10	1.30	466.97	165.39	186.07	112.51
	60	1.00	309.84	116.90	128.87	110.23
	110	0.82	267.83	98.16	108.20	110.23
	160	0.84	249.26	92.49	101.01	109.21
65-300Hz PWR HARM	10	0.19	13.52	4.92	5.27	107.15
	60	0.14	8.36	3.46	3.62	104.65
	110	0.13	7.74	2.94	3.03	103.18
	160	0.18	7.64	2.91	2.98	102.48
305-2560Hz HIGH FREQ	10	0.65	13.20	4.85	4.80	98.92
	60	0.47	8.17	3.44	3.31	96.19
	110	0.46	7.69	2.97	2.81	94.47
	160	0.48	7.60	3.00	2.80	93.35
5-2560Hz ALL FREQ	10	1.49	467.48	165.64	186.21	112.42
	60	1.14	310.14	117.08	128.96	110.15
	110	0.96	268.11	98.32	108.27	110.12
	160	1.01	249.54	92.66	101.08	109.08

APPENDIX AE

DATASET TGV030  
UNDERPASS

Measurement Setup Code:           Staff: 31       Reference: 32  
  Drawing: A-8

Vehicle Status:                    A train set passed 159 seconds  
  into the record

Measurement Date:                 September 9, 1992

Measurement Time:                 Start:     13:23:54  
  End:       13:29:03

Number of Samples:                23

Programmed Sample Interval:      10 sec

Actual Sample Interval:           14.1 sec

Frequency Spectrum Parameters

<u>Probe Type:</u>	<u>Wideband</u>	<u>Static</u>
Maximum Frequency (Hz)	2560	64
Minimum Frequency (Hz)	5	0
Spectral Bandwidth (Hz)	5	1

Missing or Suspect Data:         None

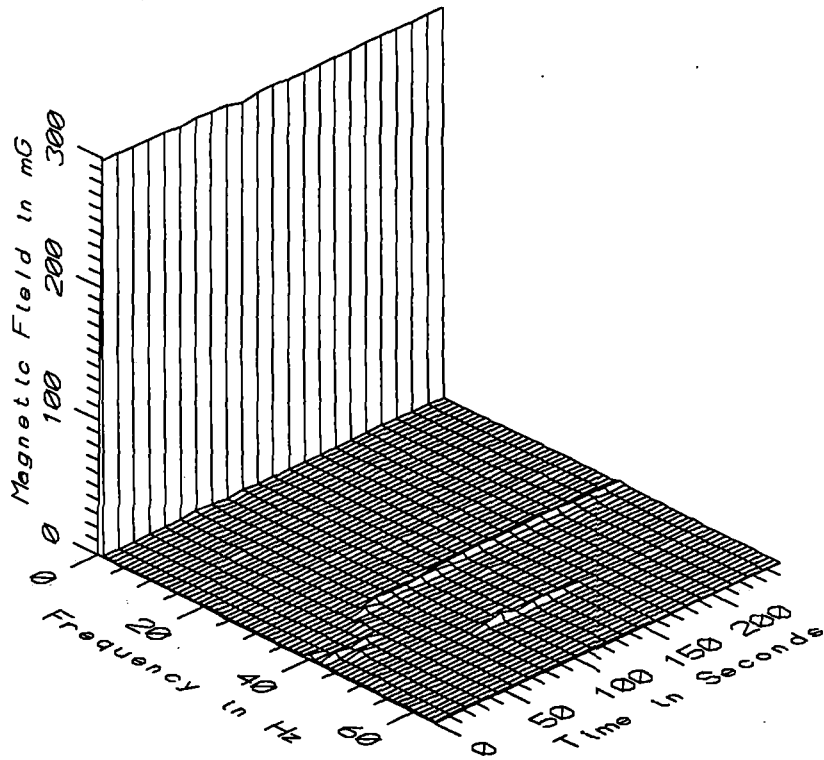

TGV030 - 10cm ABOVE GROUND UNDER TOURS BOUND LINE AT UNDERPASS

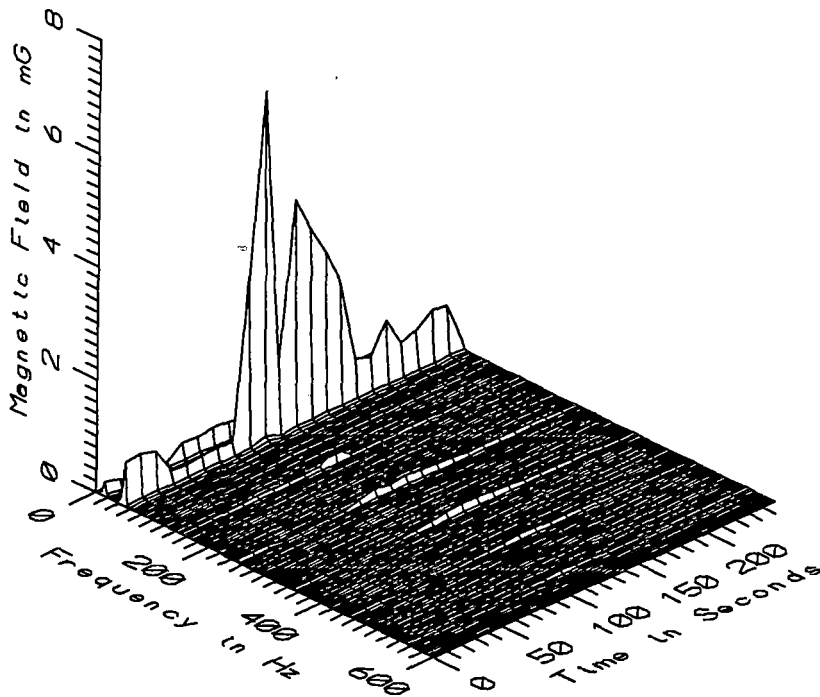

TGV030 - 10cm ABOVE GROUND UNDER TOURS BOUND LINE AT UNDERPASS

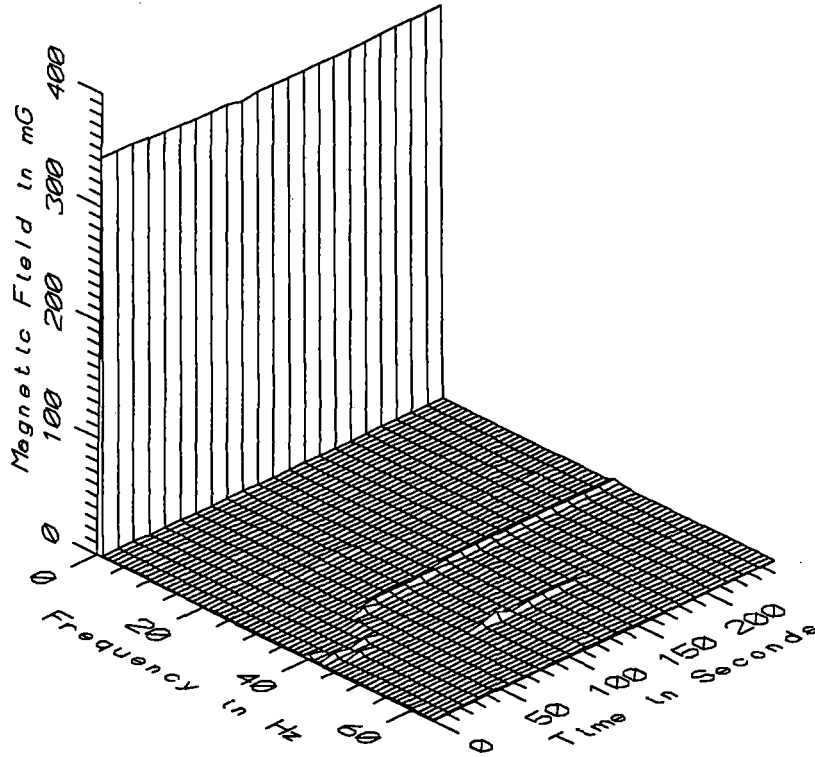

TGV030 - 60cm ABOVE GROUND UNDER TOURS BOUND LINE AT UNDERPASS

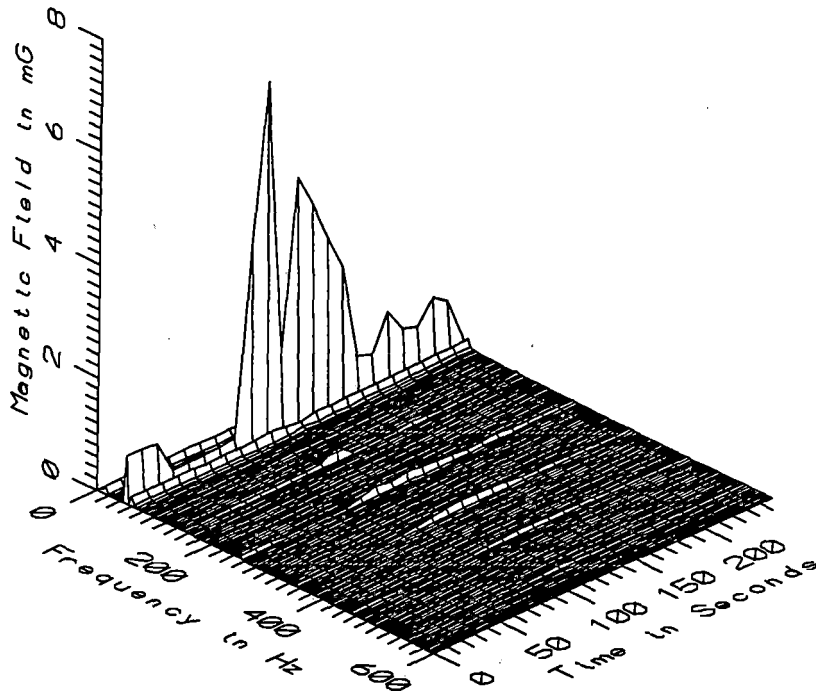

TGV030 - 60cm ABOVE GROUND UNDER TOURS BOUND LINE AT UNDERPASS



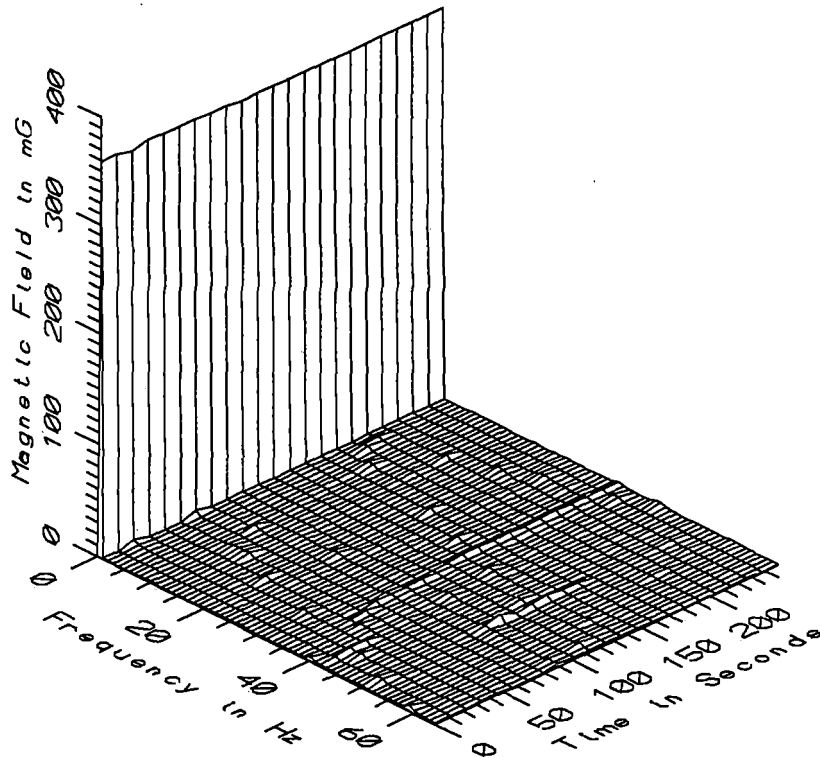

TGV030 - 110cm ABOVE GROUND UNDER TOURS BOUND LINE AT UNDERPASS

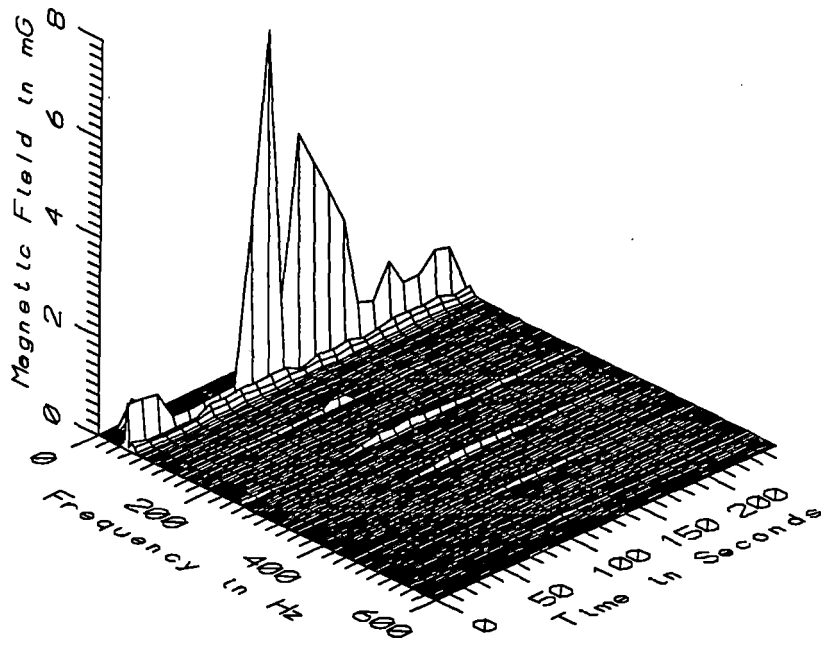

TGV030 - 110cm ABOVE GROUND UNDER TOURS BOUND LINE AT UNDERPASS

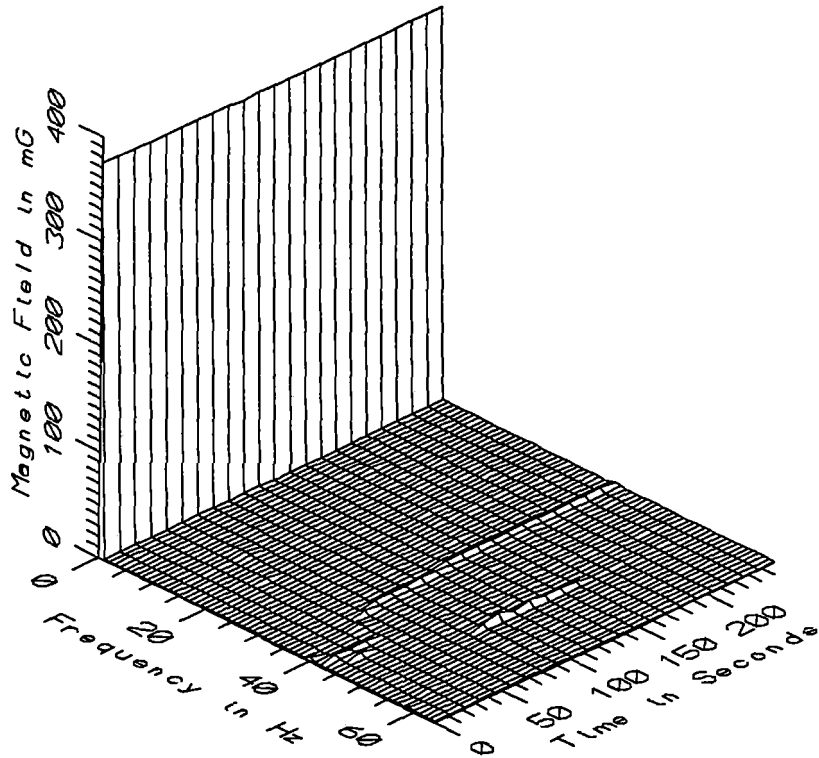

TGV030 - 160cm ABOVE GROUND UNDER TOURS BOUND LINE AT UNDERPASS

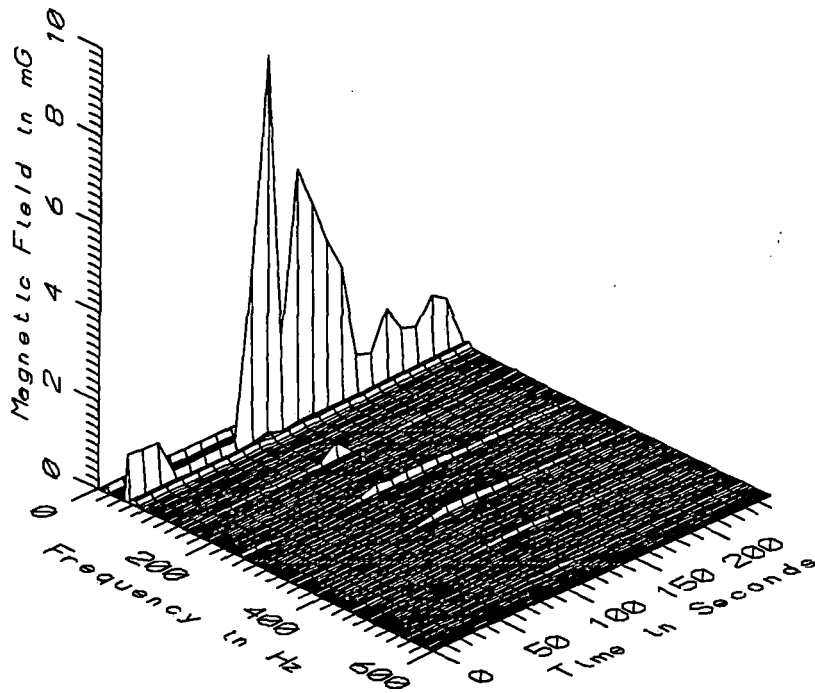

TGV030 - 160cm ABOVE GROUND UNDER TOURS BOUND LINE AT UNDERPASS

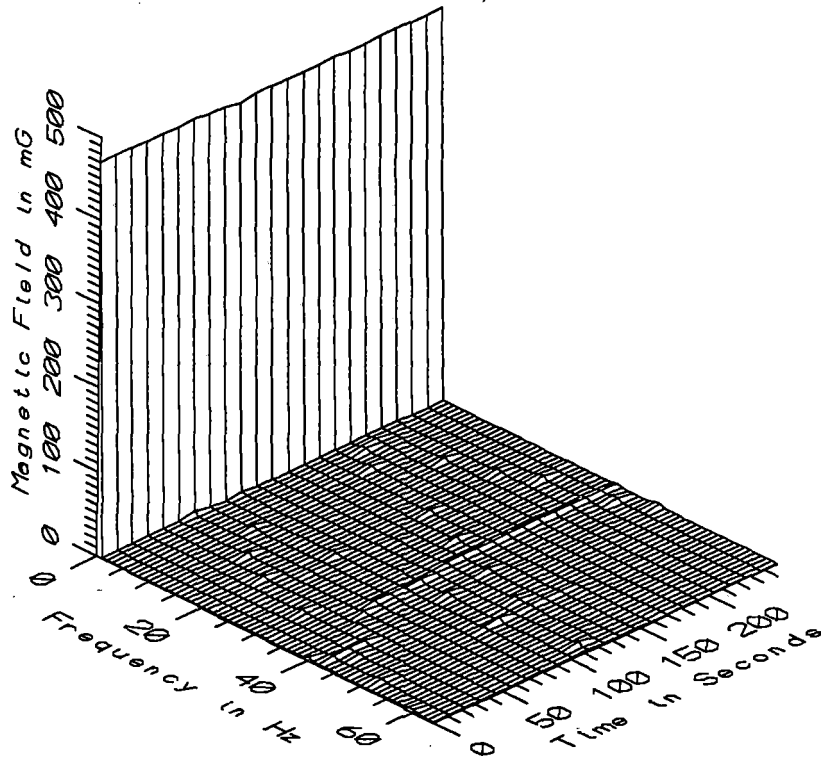

TGV030 - REFERENCE PROBE - ON GROUND 14.5ft FROM STAFF AT UNDERPASS

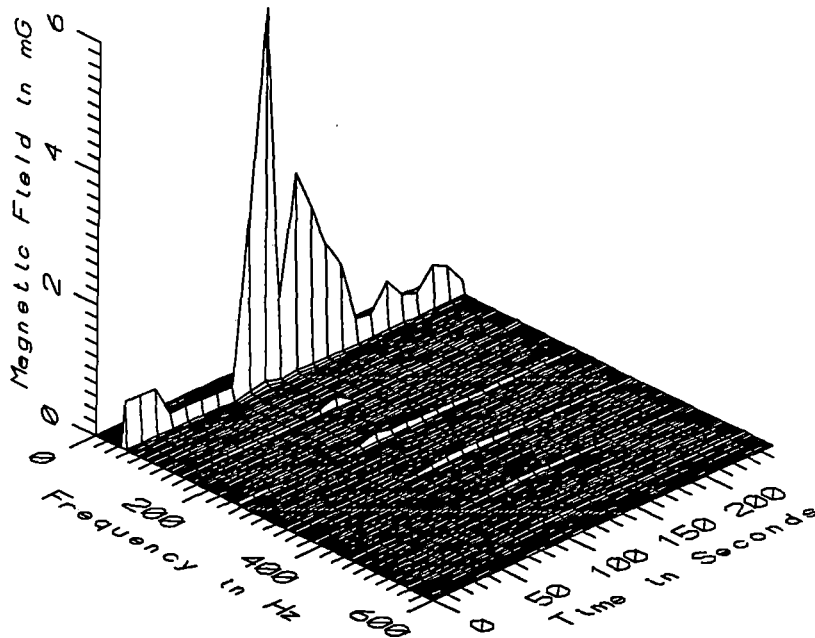

TGV030 - REFERENCE PROBE - ON GROUND 14.5ft FROM STAFF AT UNDERPASS

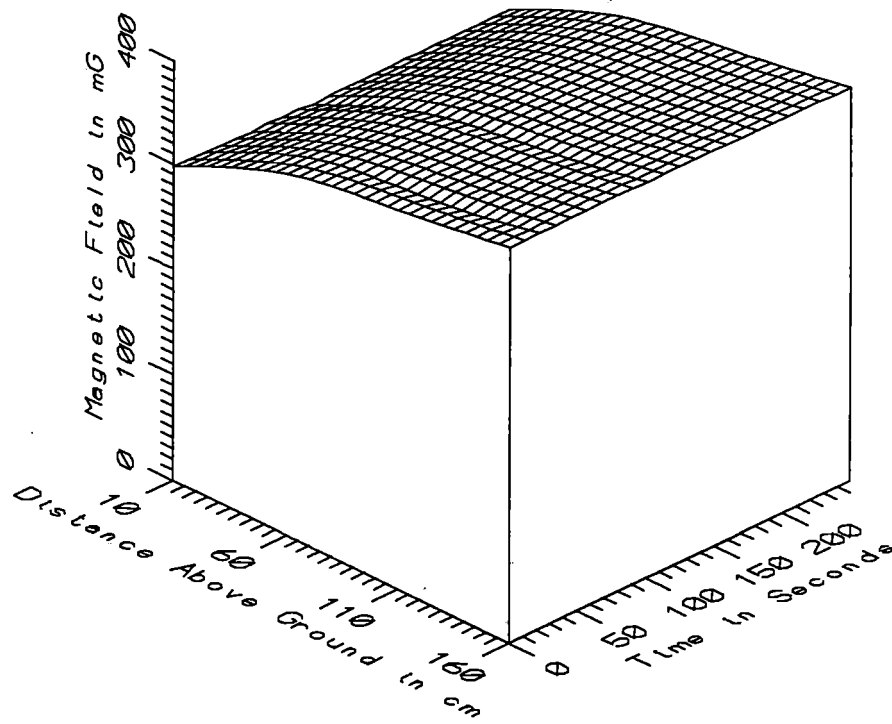

TGV030 - UNDER TOURS BOUND LINE AT UNDERPASS - STATIC

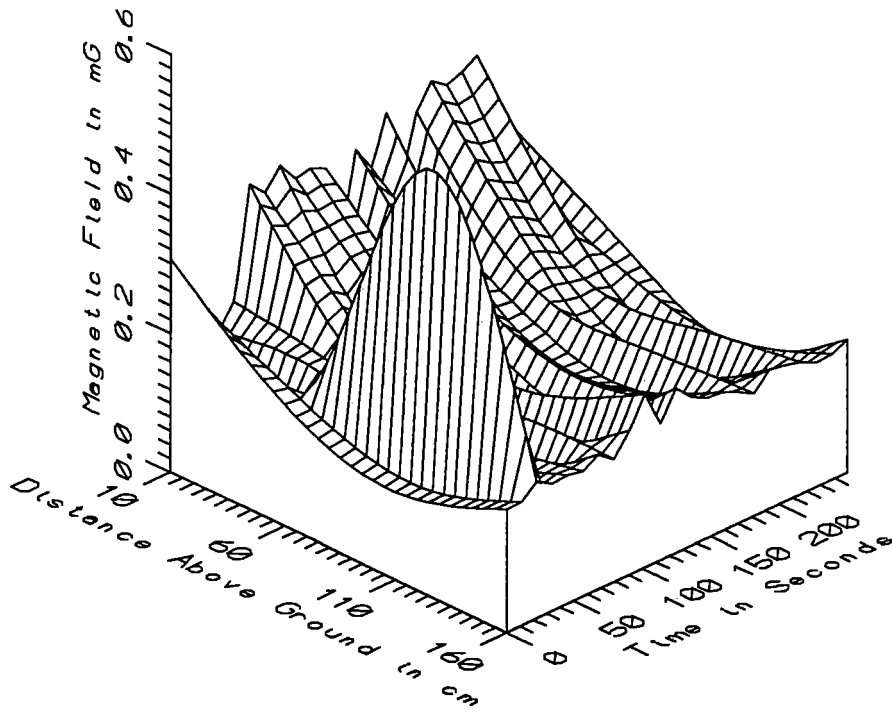

TGV030 - UNDER TOURS BOUND LINE AT UNDERPASS - LOW FREQ, 5-45Hz

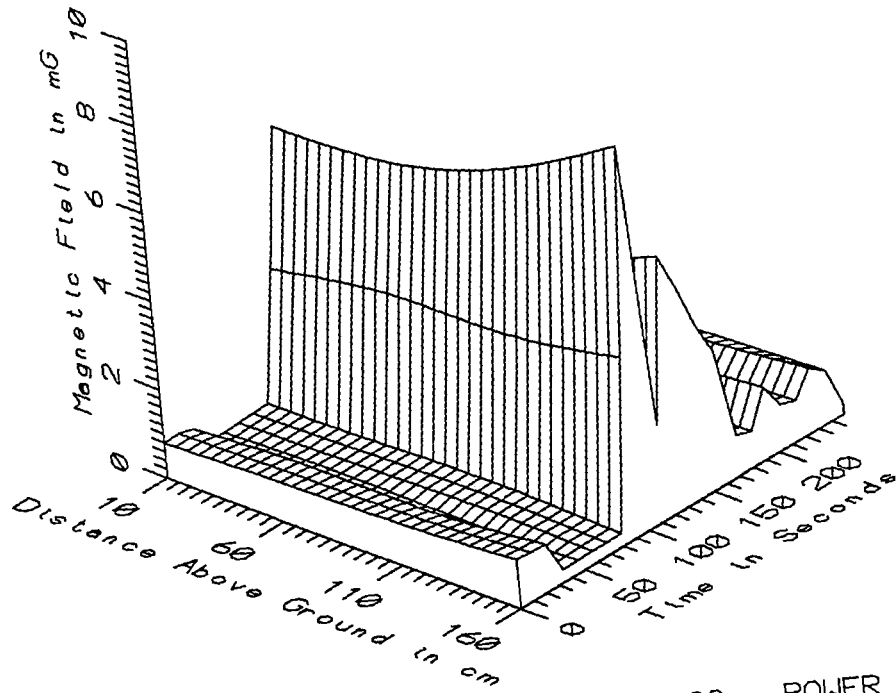

TGV030 - UNDER TOURS BOUND LINE AT UNDERPASS - POWER FREQ, 50-60Hz

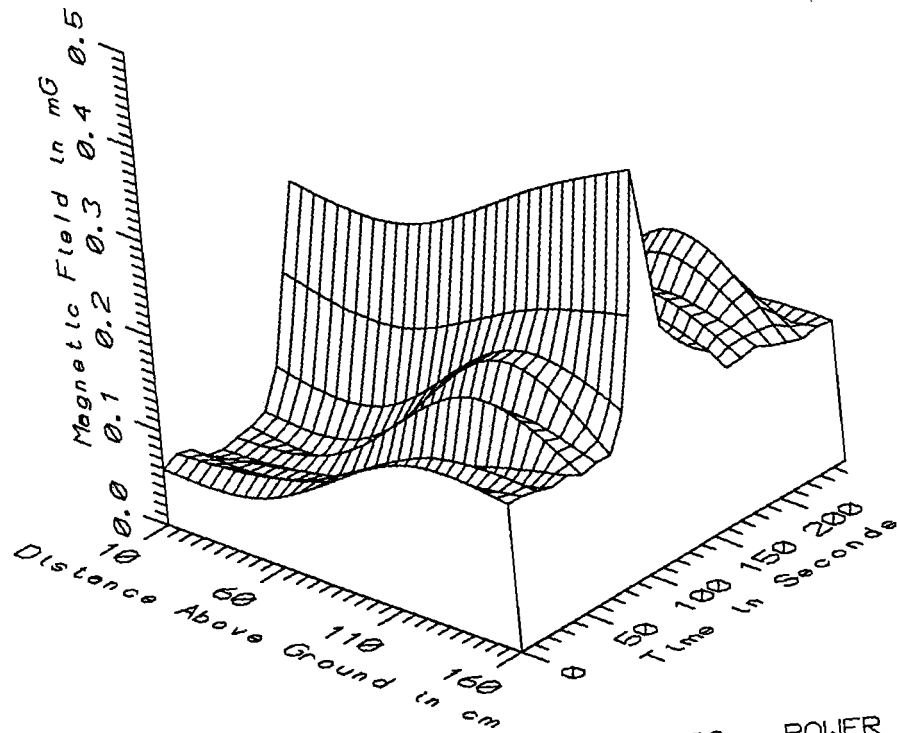

TGV030 - UNDER TOURS BOUND LINE AT UNDERPASS - POWER HARM, 65-300Hz

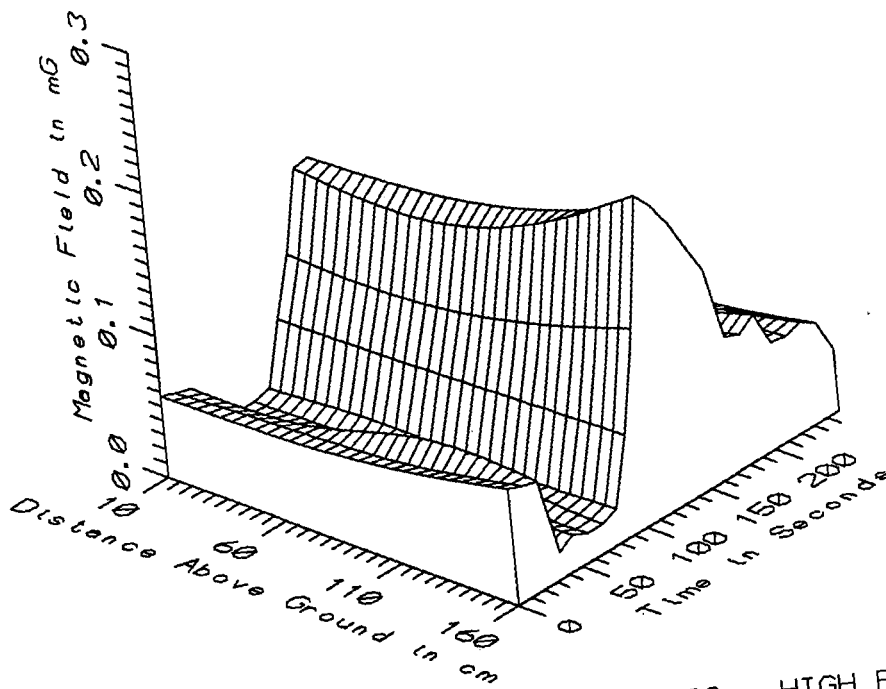

TGV030 - UNDER TOURS BOUND LINE AT UNDERPASS - HIGH FREQ, 305-2560Hz

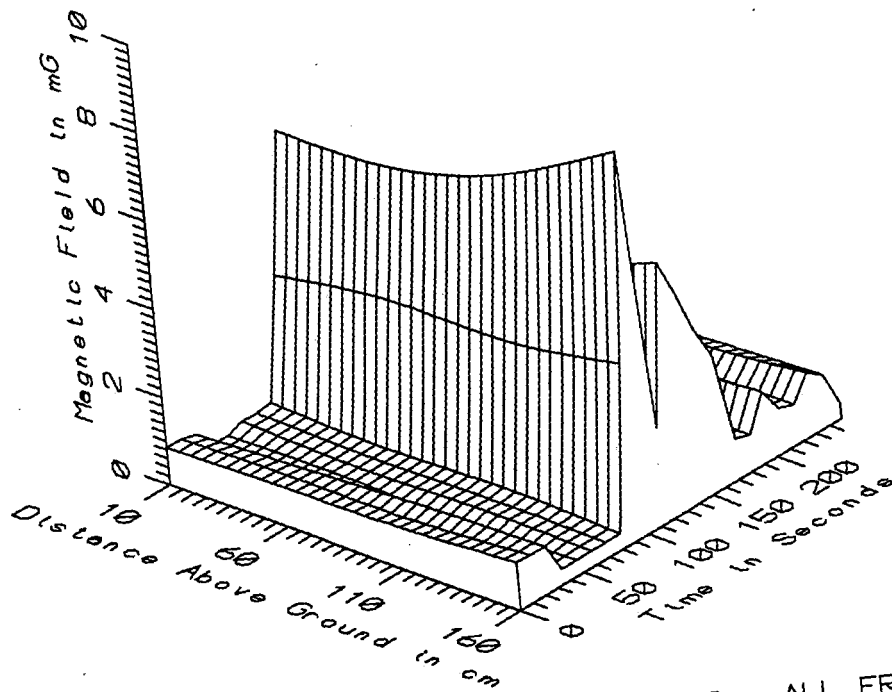

TGV030 - UNDER TOURS BOUND LINE AT UNDERPASS - ALL FREQ, 5-2560Hz

TGV030 - UNDERPASS - UNDERNEATH PARIS BOUND LINE				TOTAL OF 23 SAMPLES		
FREQUENCY BAND	HEIGHT ABOVE GROUND (cm)	MINIMUM MAGNETIC FIELD (mG)	MAXIMUM MAGNETIC FIELD (mG)	AVERAGE MAGNETIC FIELD (mG)	STANDARD DEVIATION (mG)	COEFFICIENT OF VARIATION (%)
STATIC	10	295.28	298.45	297.43	0.57	0.19
	60	338.98	342.64	341.21	0.78	0.23
	110	355.99	359.75	358.91	0.83	0.23
	160	374.55	376.36	375.56	0.53	0.14
5-45Hz LOW FREQ	10	0.17	0.39	0.31	0.07	21.47
	60	0.17	0.21	0.18	0.01	5.67
	110	0.07	0.57	0.15	0.10	64.53
	160	0.18	0.25	0.20	0.02	9.41
50-60Hz PWR FREQ	10	0.18	6.20	1.42	1.53	107.76
	60	0.25	6.36	1.55	1.62	104.29
	110	0.23	7.19	1.68	1.79	106.10
	160	0.25	8.68	1.96	2.15	109.56
65-300Hz PWR HARM	10	0.04	0.27	0.09	0.05	61.59
	60	0.06	0.27	0.10	0.05	47.03
	110	0.10	0.35	0.18	0.05	28.55
	160	0.14	0.42	0.18	0.06	33.84
305-2560Hz HIGH FREQ	10	0.02	0.16	0.07	0.04	66.16
	60	0.02	0.16	0.07	0.04	62.00
	110	0.02	0.18	0.08	0.05	63.88
	160	0.02	0.23	0.09	0.06	67.16
5-2560Hz ALL FREQ	10	0.31	6.22	1.49	1.50	100.19
	60	0.32	6.37	1.58	1.60	101.43
	110	0.30	7.20	1.72	1.77	102.58
	160	0.35	8.69	2.00	2.13	106.22





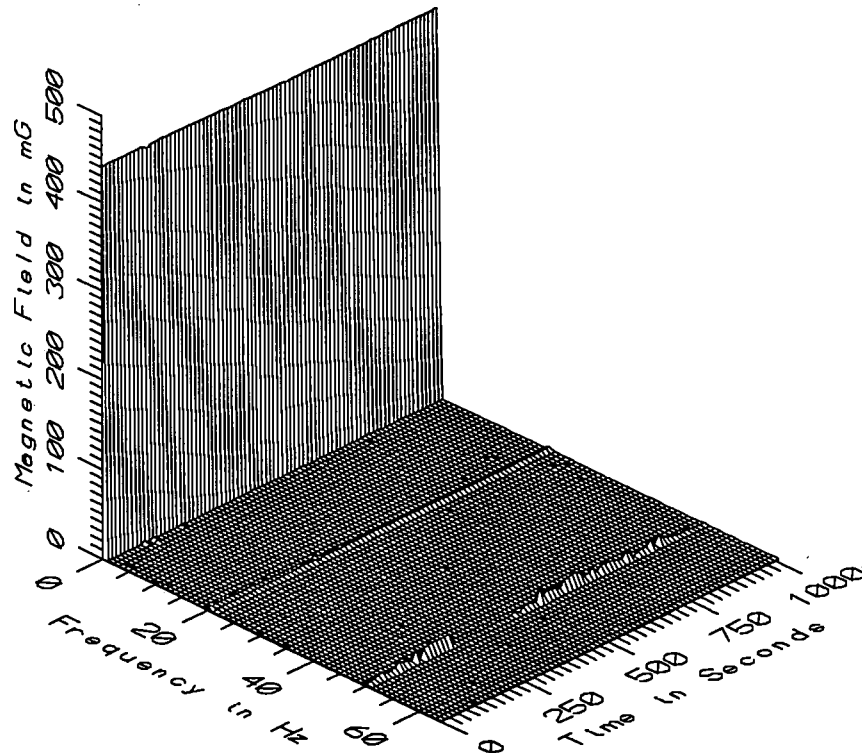

TGV031 - 10cm ABOVE GROUND 7.5m FROM PARIS BOUND LINE AT WAYSIDE

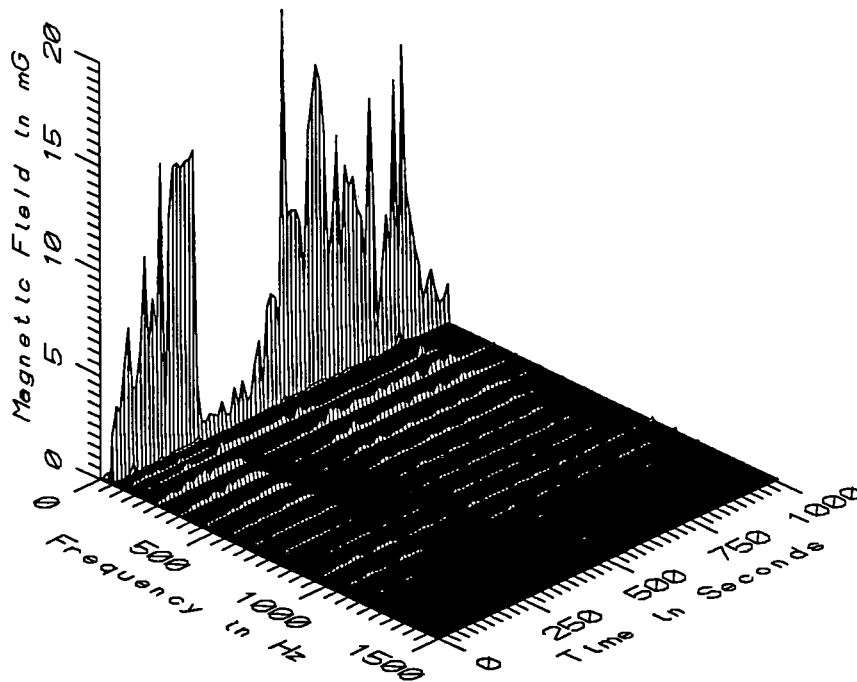

TGV031 - 10cm ABOVE GROUND 7.5m FROM PARIS BOUND LINE AT WAYSIDE

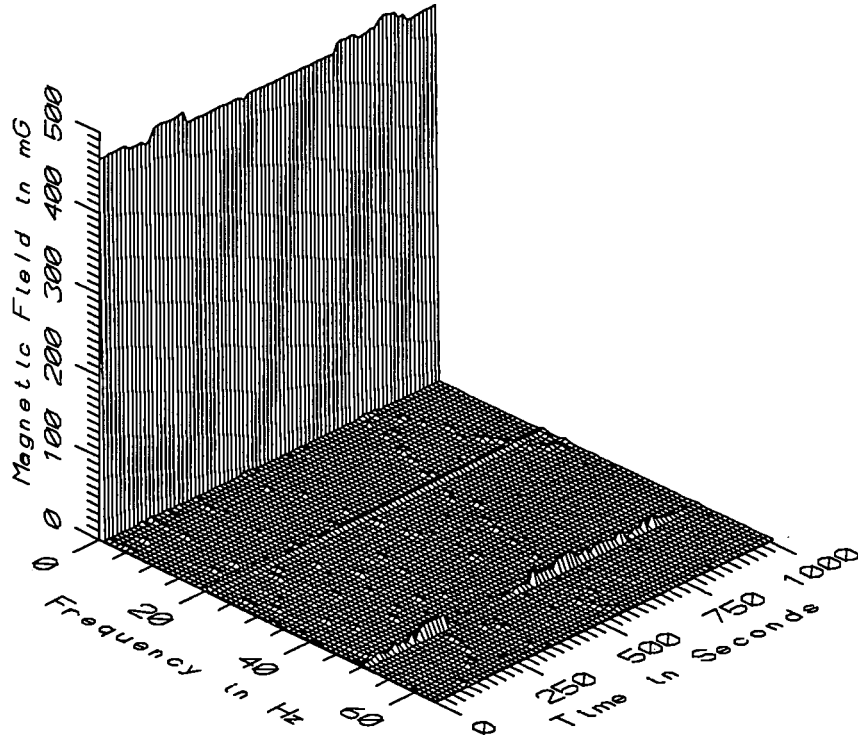

TGV031 - 110cm ABOVE GROUND 7.5m FROM PARIS BOUND LINE AT WAYSIDE

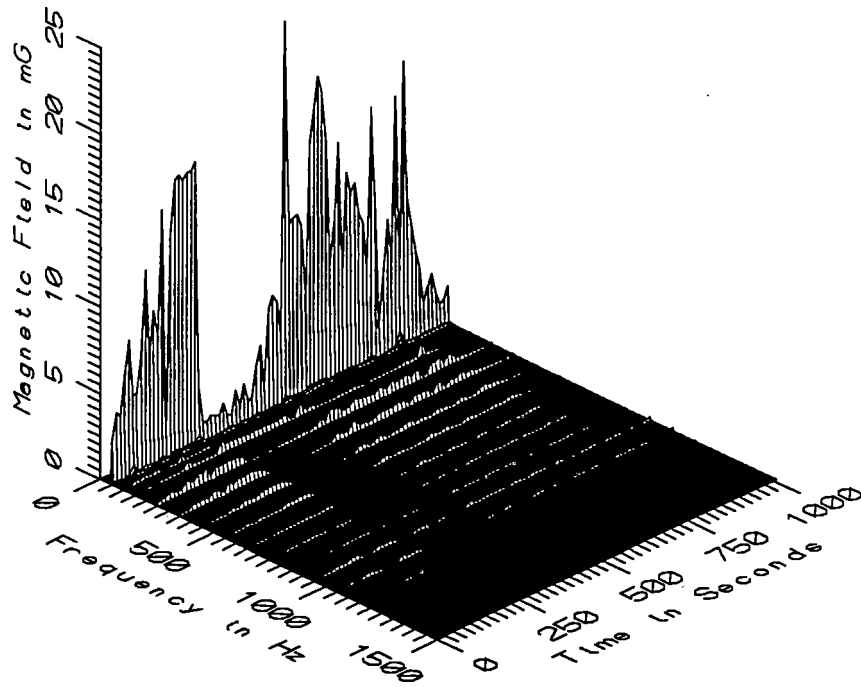

TGV031 - 110cm ABOVE GROUND 7.5m FROM PARIS BOUND LINE AT WAYSIDE

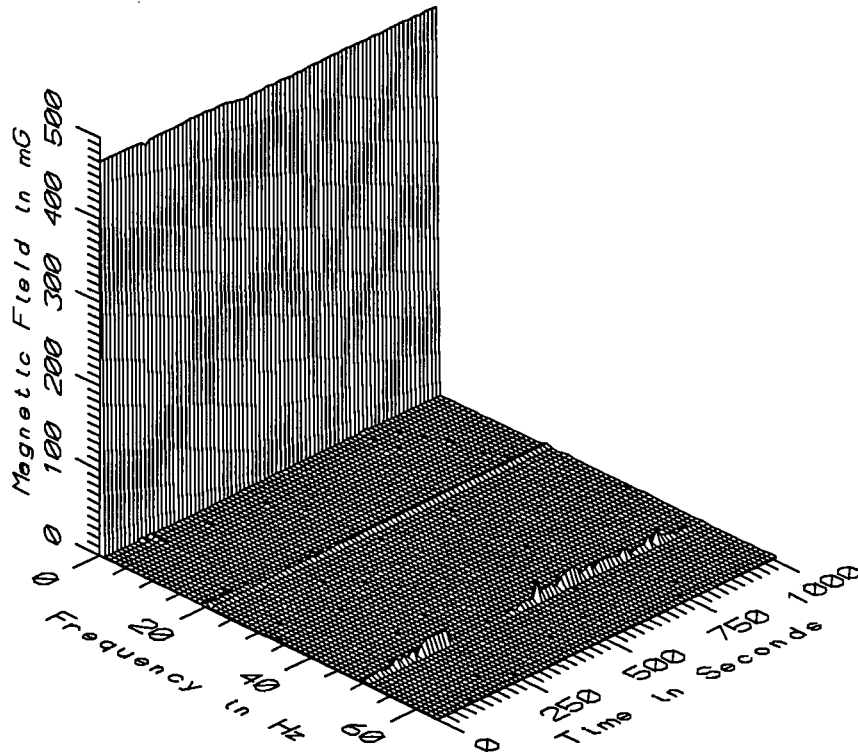

TGV031 - 160cm ABOVE GROUND 7.5m FROM PARIS BOUND LINE AT WAYSIDE

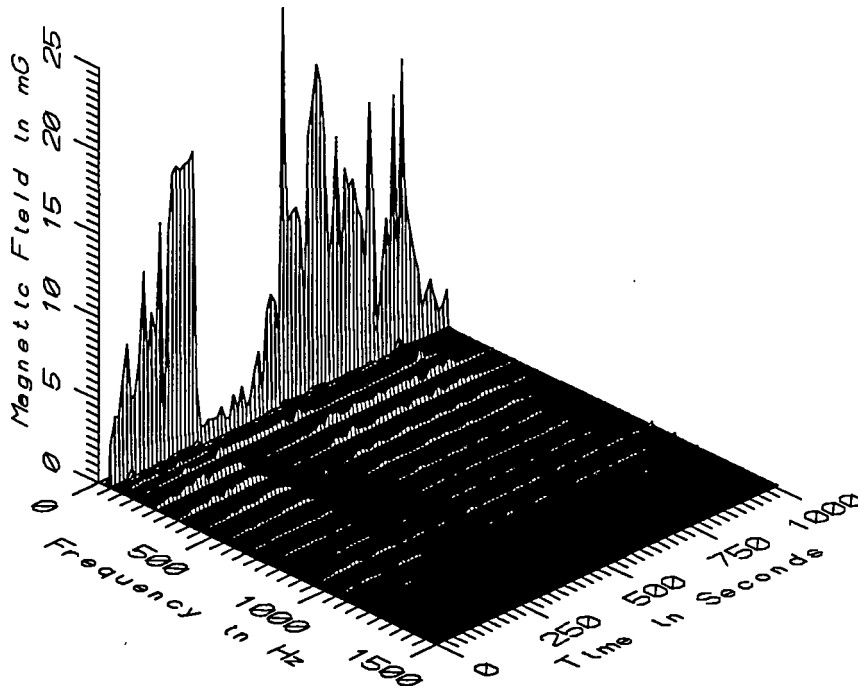

TGV031 - 160cm ABOVE GROUND 7.5m FROM PARIS BOUND LINE AT WAYSIDE

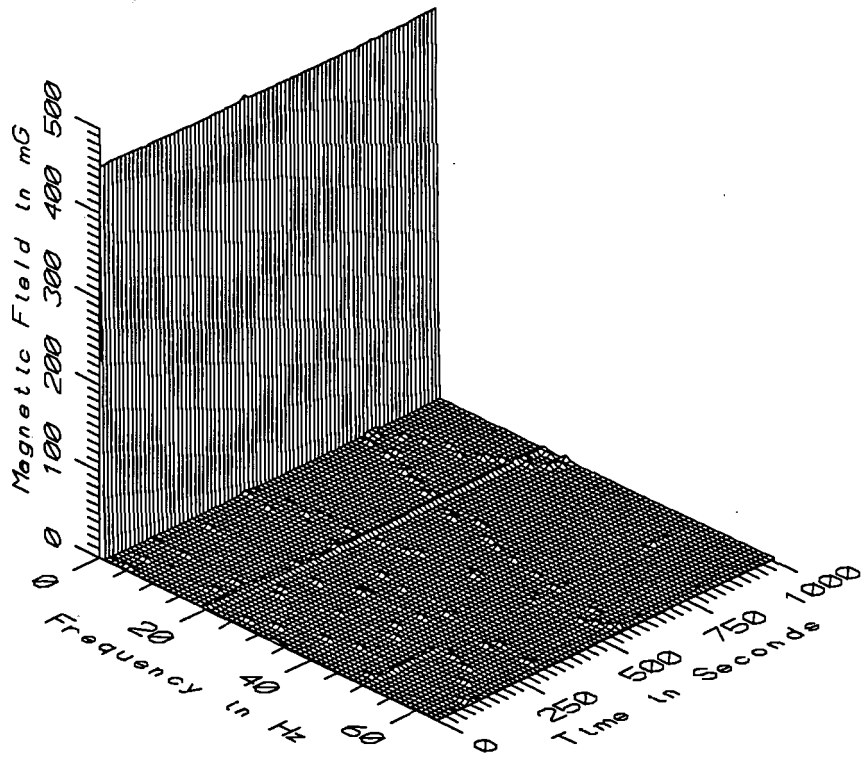

TGV031 - REFERENCE PROBE - 15m BEHIND STAFF AT WAYSIDE

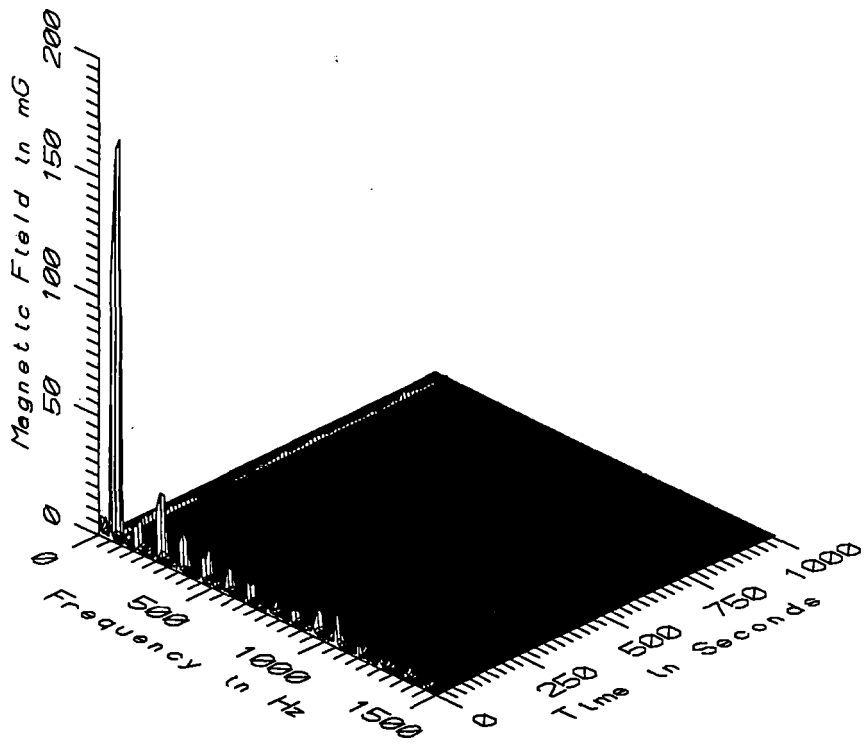

TGV031 - REFERENCE PROBE - 15m BEHIND STAFF AT WAYSIDE

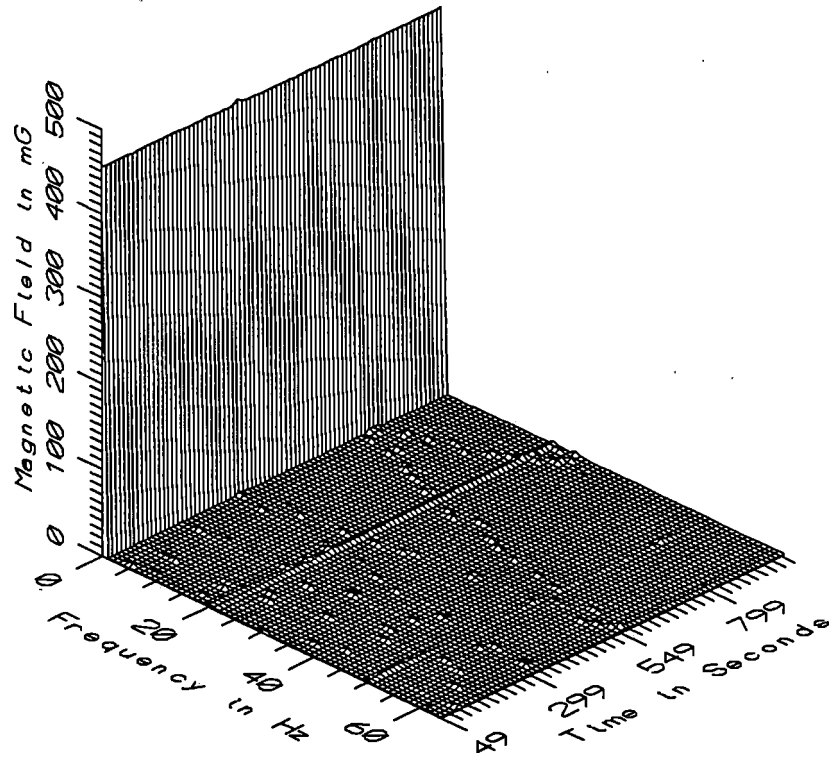

TGV031 - REFERENCE PROBE - 15m BEHIND STAFF AT WAYSIDE

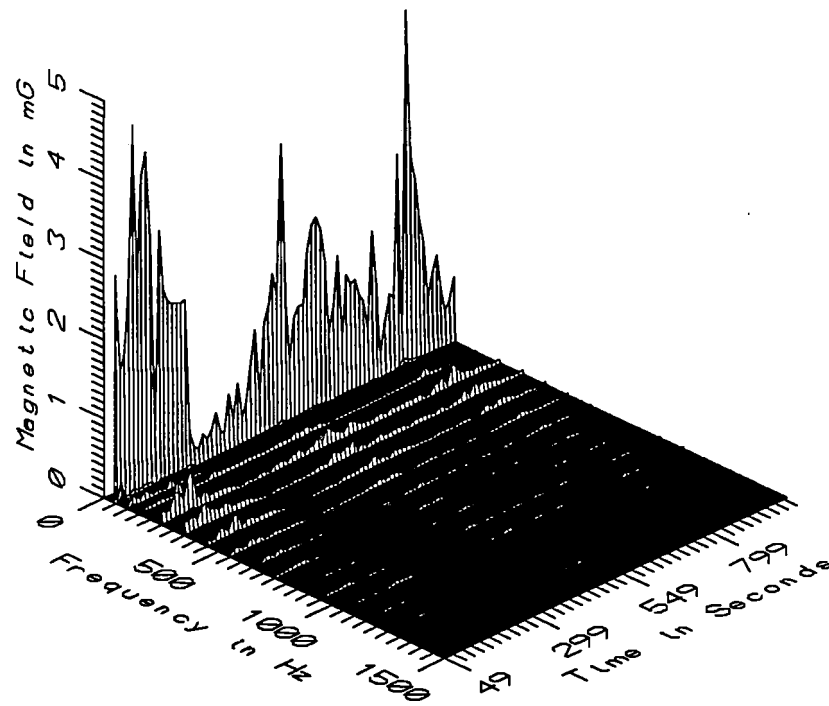

TGV031 - REFERENCE PROBE - 15m BEHIND STAFF AT WAYSIDE

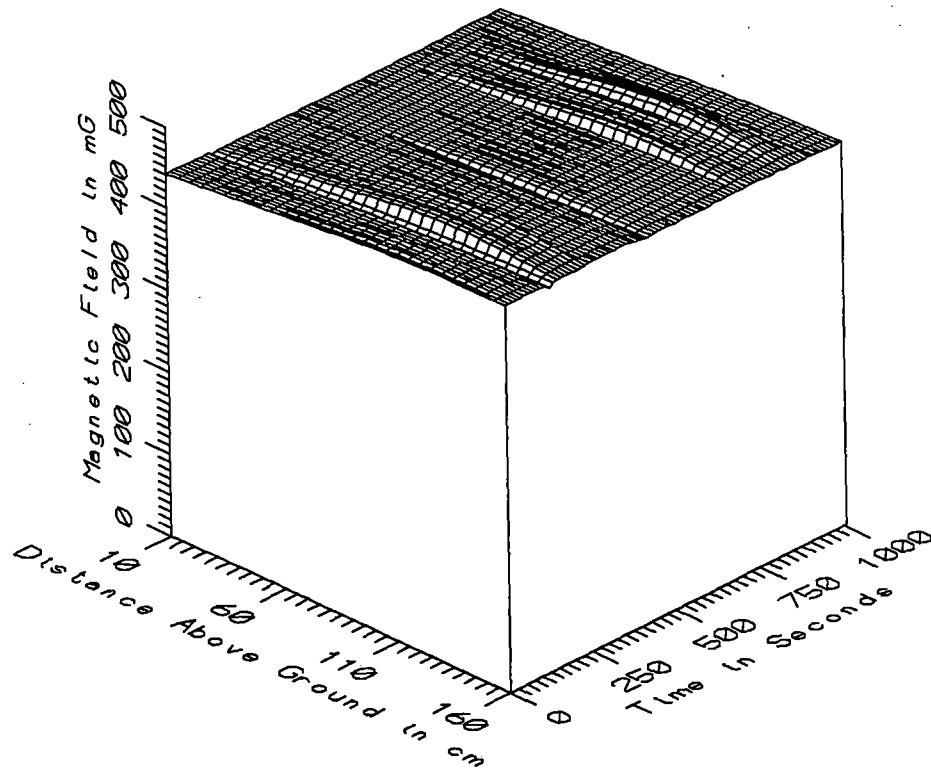

TGV031 - 7.5m FROM PARIS BOUND LINE AT WAYSIDE - STATIC

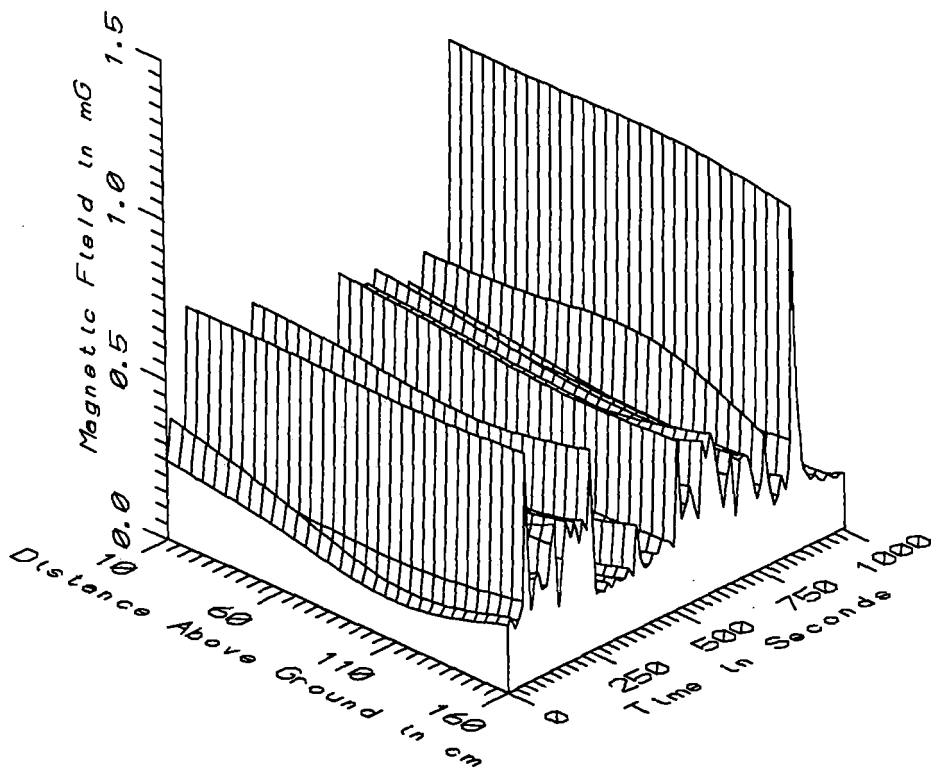

TGV031 - 7.5m FROM PARIS BOUND LINE AT WAYSIDE - LOW FREQ, 5-45Hz

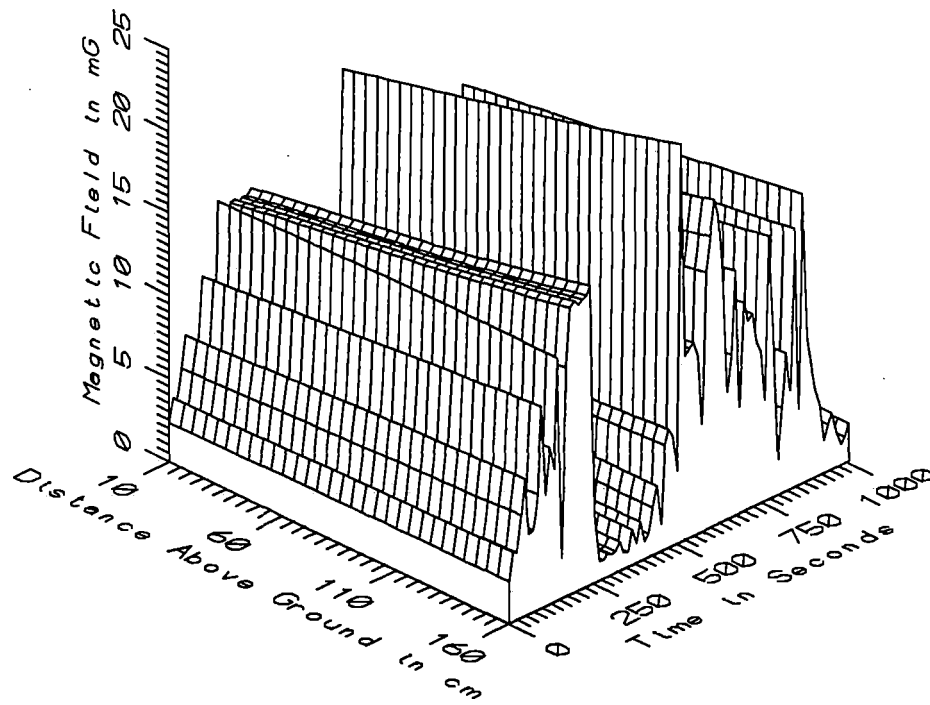

TGV031 - 7.5m FROM PARIS BOUND LINE AT WAYSIDE - POWER FREQ, 50-60Hz

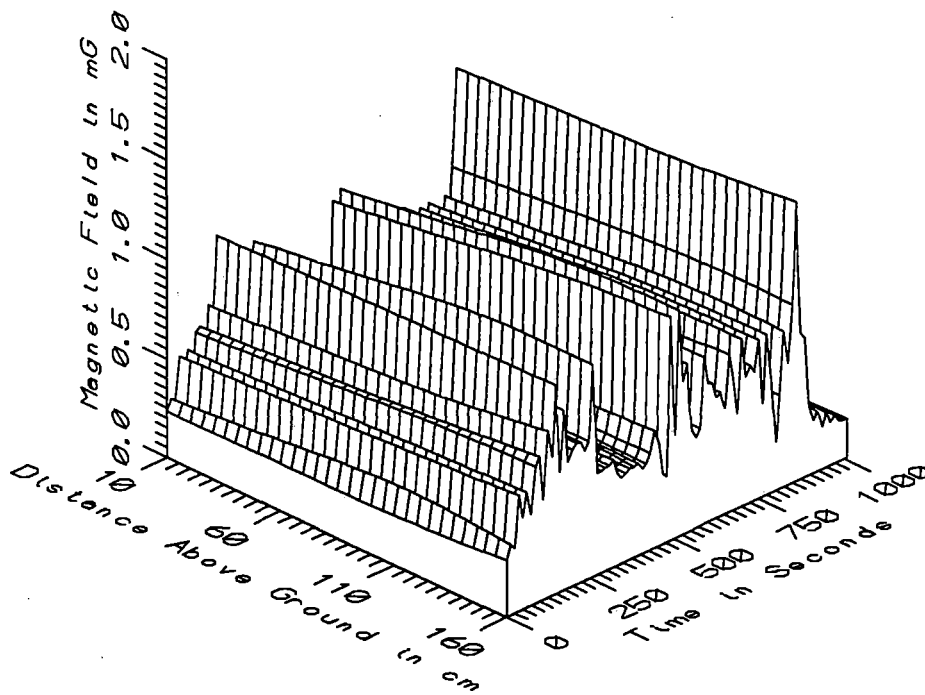

TGV031 - 7.5m FROM PARIS BOUND LINE AT WAYSIDE - POWER HARM, 65-300Hz

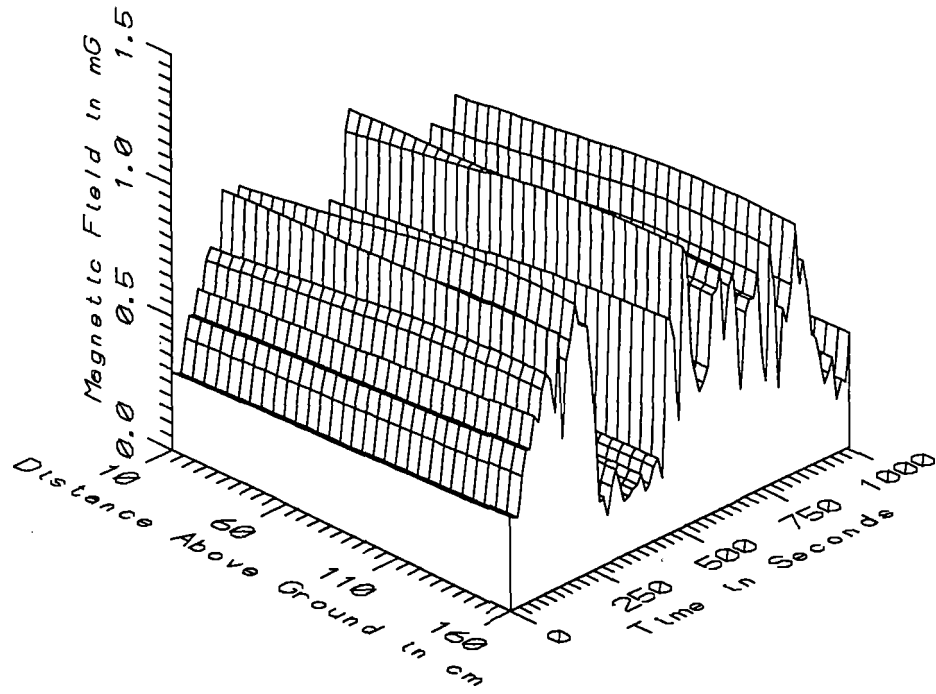

TGV031 - 7.5m FROM PARIS BOUND LINE AT WAYSIDE - HIGH FREQ, 305-2560Hz

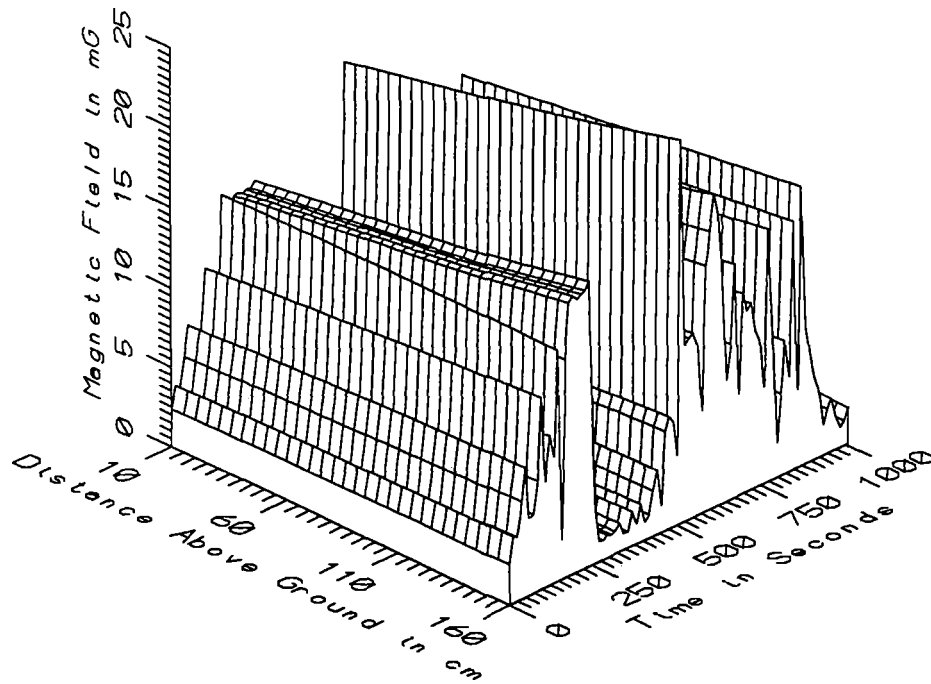

TGV031 - 7.5m FROM PARIS BOUND LINE AT WAYSIDE - ALL FREQ, 5-2560Hz



TGV031 - OPEN SPACE - 7.5m FROM PARIS BOUND TRACK					TOTAL OF 83 SAMPLES	
FREQUENCY BAND	HEIGHT ABOVE GROUND (cm)	MINIMUM MAGNETIC FIELD (mG)	MAXIMUM MAGNETIC FIELD (mG)	AVERAGE MAGNETIC FIELD (mG)	STANDARD DEVIATION (mG)	COEFFICIENT OF VARIATION (%)
STATIC	10	438.36	442.84	441.64	0.55	0.12
	110	457.94	483.11	467.23	6.04	1.29
	160	465.74	472.07	469.41	1.36	0.29
5-45Hz LOW FREQ	10	0.12	1.11	0.33	0.14	42.87
	110	0.05	1.13	0.23	0.17	72.81
	160	0.17	1.08	0.30	0.14	48.20
50-60Hz PWR FREQ	10	0.67	18.82	6.37	4.66	73.21
	110	0.79	22.06	7.30	5.39	73.82
	160	0.86	23.98	7.85	5.85	74.60
65-300Hz PWR HARM	10	0.11	1.26	0.47	0.21	44.78
	110	0.18	1.34	0.57	0.23	39.65
	160	0.20	1.41	0.59	0.23	39.90
305-2560Hz HIGH FREQ	10	0.15	0.97	0.48	0.22	45.83
	110	0.18	1.04	0.55	0.25	45.31
	160	0.18	1.05	0.57	0.25	44.45
5-2560Hz ALL FREQ	10	0.82	18.88	6.43	4.64	72.16
	110	0.93	22.12	7.37	5.37	72.88
	160	1.01	24.04	7.92	5.83	73.66

APPENDIX AG

DATASET TGV032  
BEHIND GAULT ST. DENIS SUBSTATION

Measurement Setup Code:        Staff: 35        Reference: 36  
   Drawing: A-10

Vehicle Status:                A single stain set to Paris passed  
   during the record

Measurement Date:              September 9, 1992

Measurement Time:              Start:        15:18:21  
   End:         15:22:20

Number of Samples:             25

Programmed Sample Interval:   10 sec

Actual Sample Interval:        10.0 sec

Frequency Spectrum Parameters

<u>Probe Type:</u>	<u>Wideband</u>	<u>Static</u>
Maximum Frequency (Hz)	2560	64
Minimum Frequency (Hz)	5	0
Spectral Bandwidth (Hz)	5	1

Missing or Suspect Data:        None

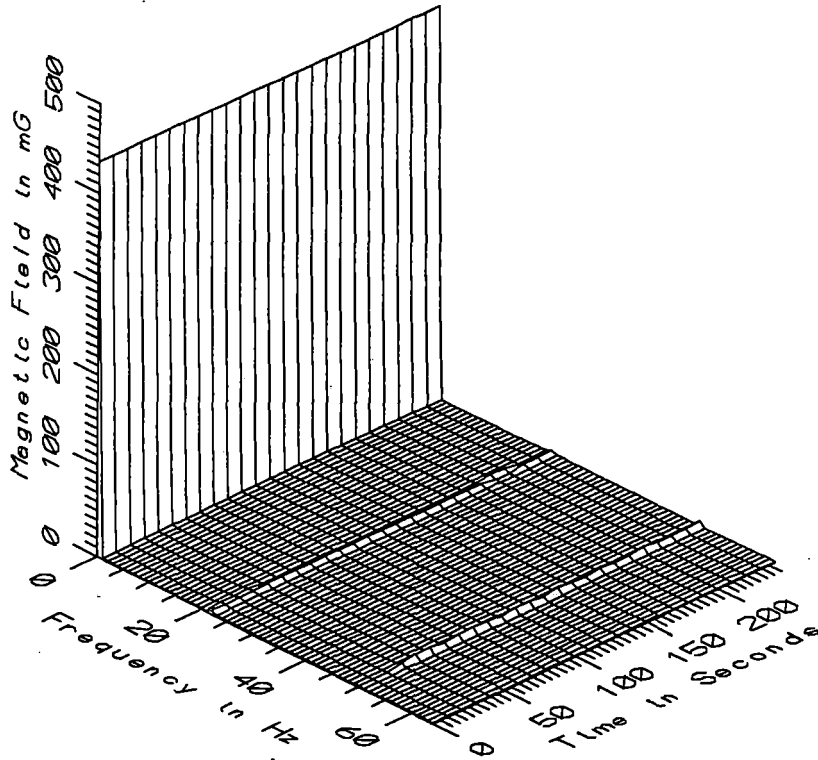

TGV032 - 10cm ABOVE GROUND NEAR FENCE OF GAULT ST. DENIS SUBSTATION

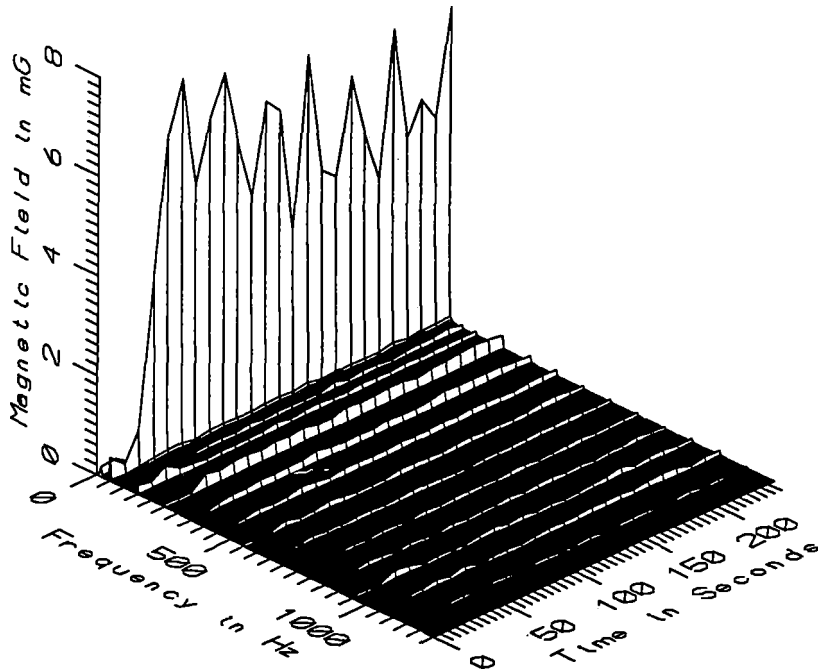

TGV032 - 10cm ABOVE GROUND NEAR FENCE OF GAULT ST. DENIS SUBSTATION

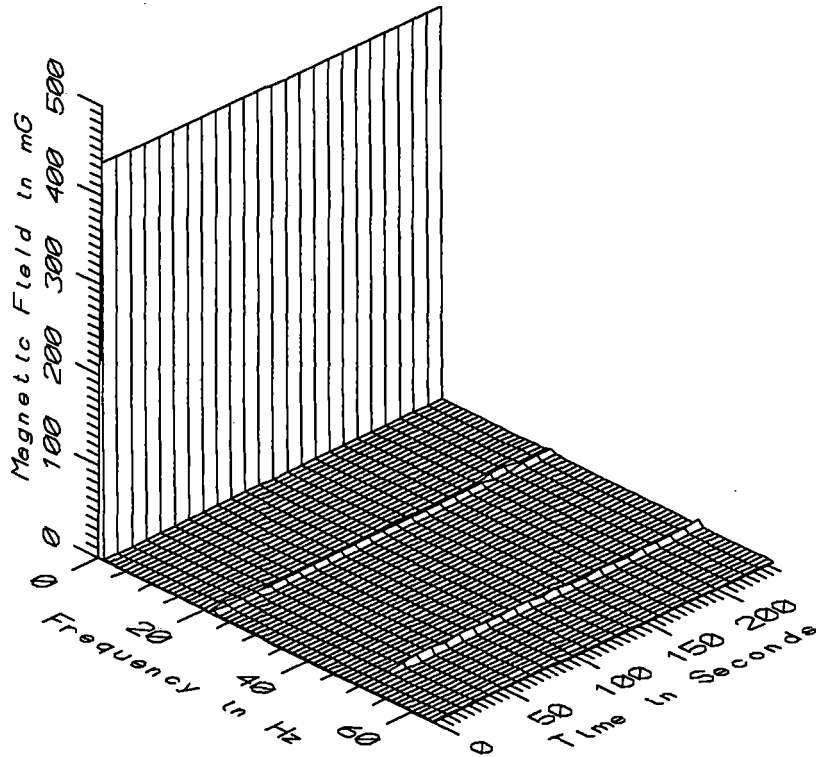

TGV032 - 60cm ABOVE GROUND NEAR FENCE OF GAULT ST. DENIS SUBSTATION

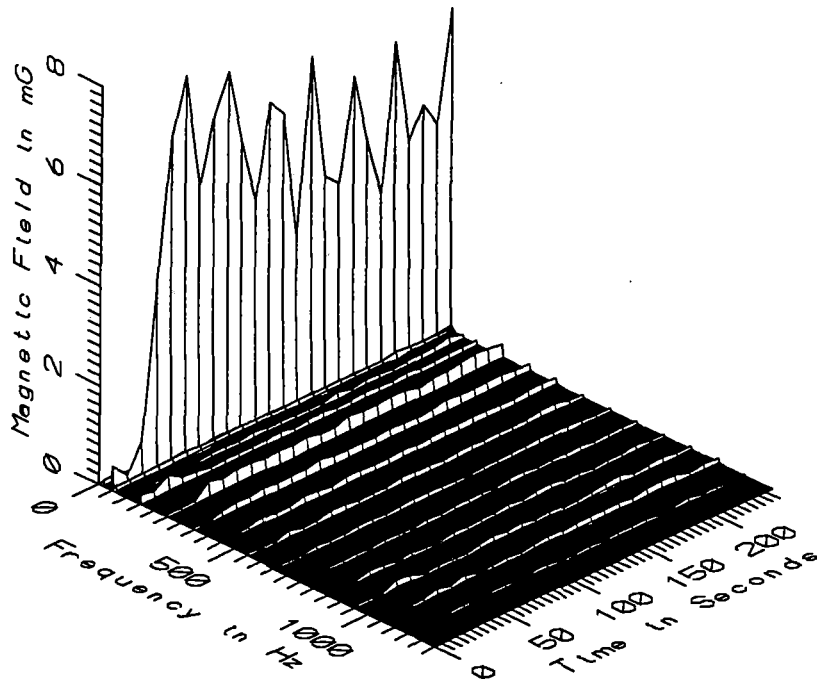

TGV032 - 60cm ABOVE GROUND NEAR FENCE OF GAULT ST. DENIS SUBSTATION

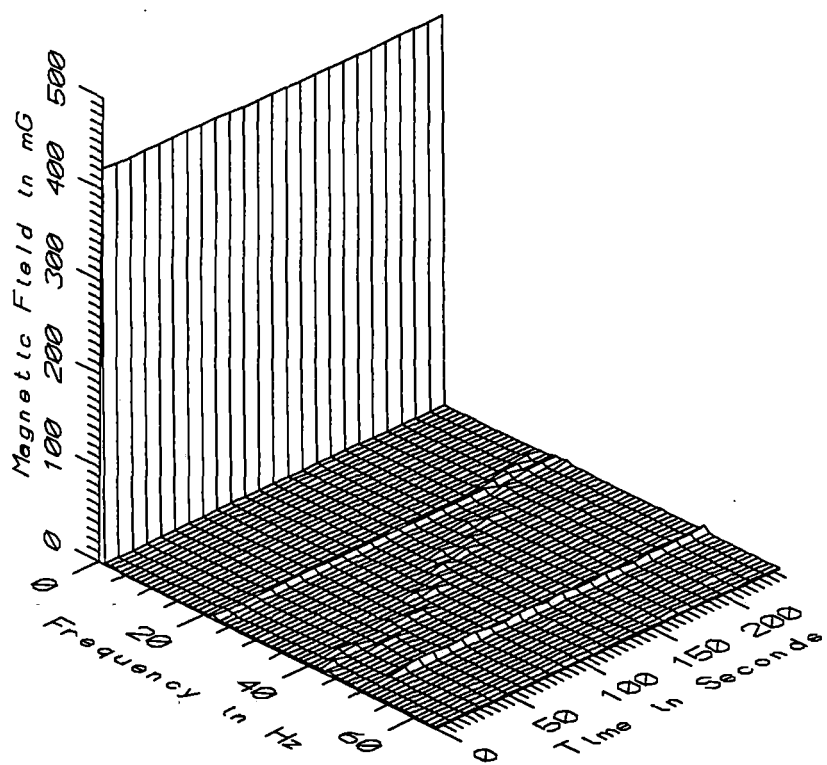

TGV032 - 110cm ABOVE GROUND NEAR FENCE OF GAULT ST. DENIS SUBSTATION

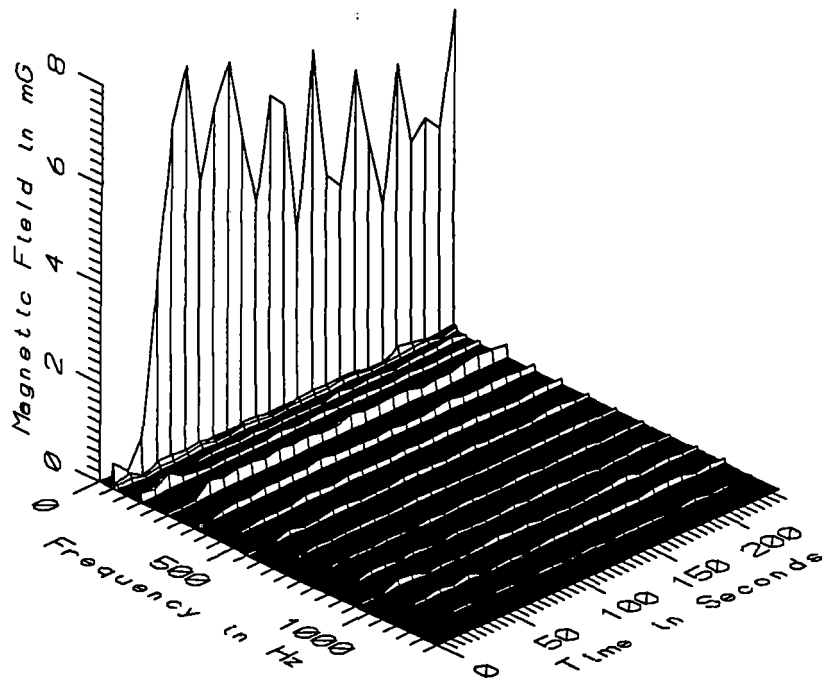

TGV032 - 110cm ABOVE GROUND NEAR FENCE OF GAULT ST. DENIS SUBSTATION

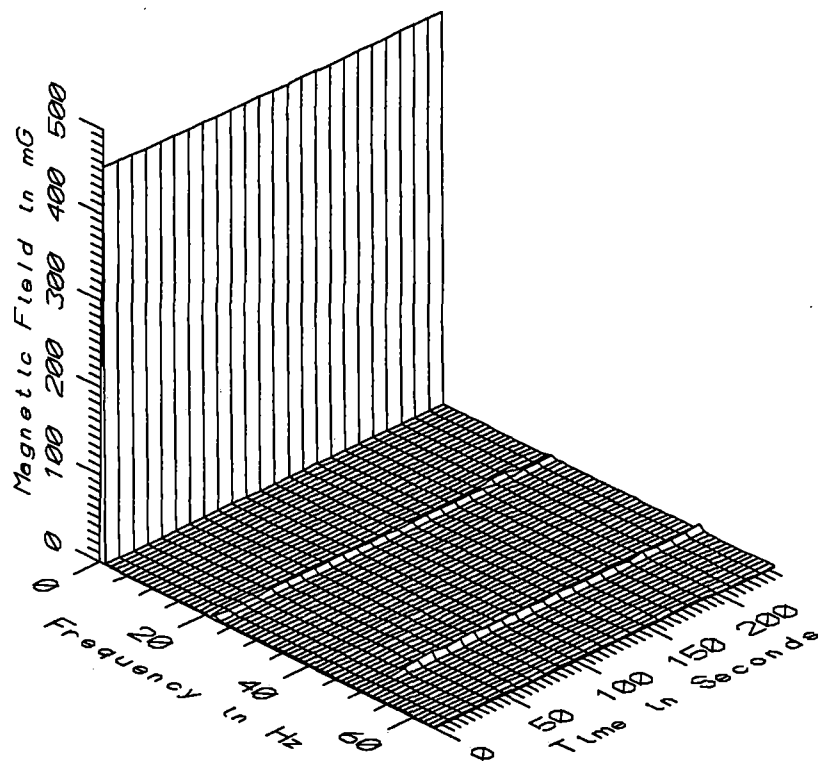

TGV032 - 160cm ABOVE GROUND NEAR FENCE OF GAULT ST. DENIS SUBSTATION

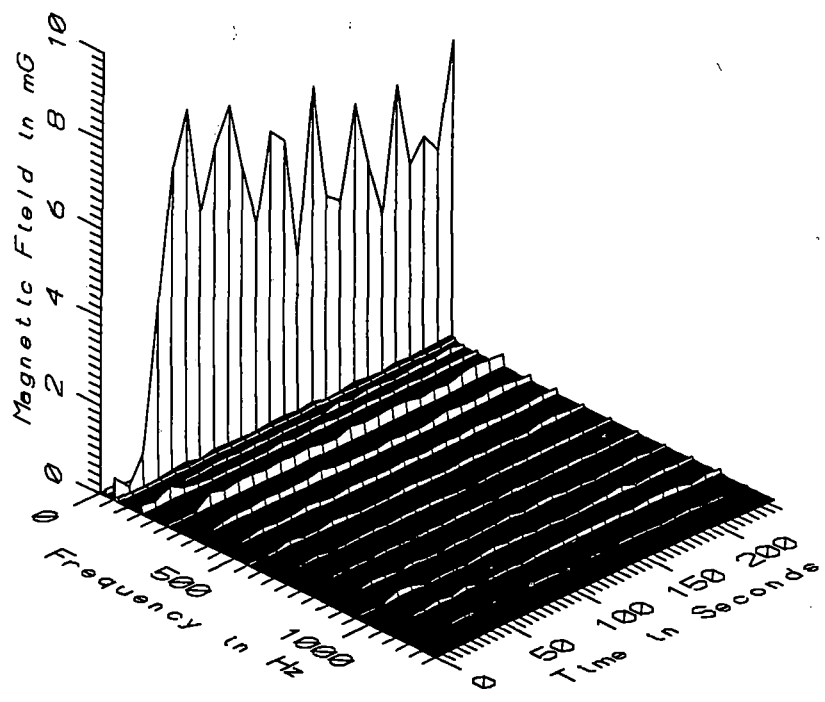

TGV032 - 160cm ABOVE GROUND NEAR FENCE OF GAULT ST. DENIS SUBSTATION

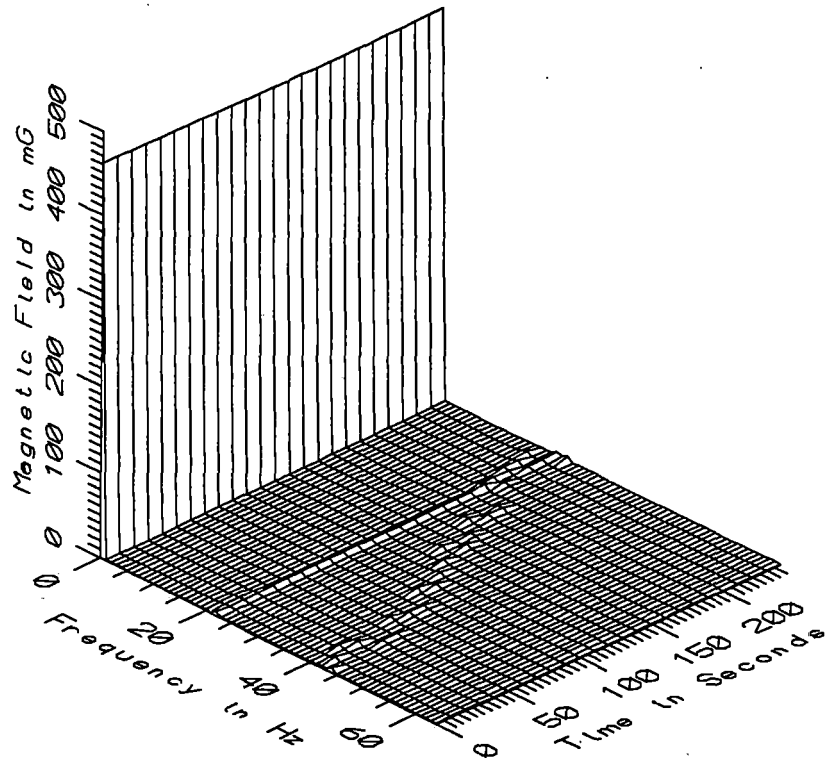

TGV032 - REFERENCE PROBE - 15m BEHIND STAFF, GAULT ST. DENIS SUBSTATION

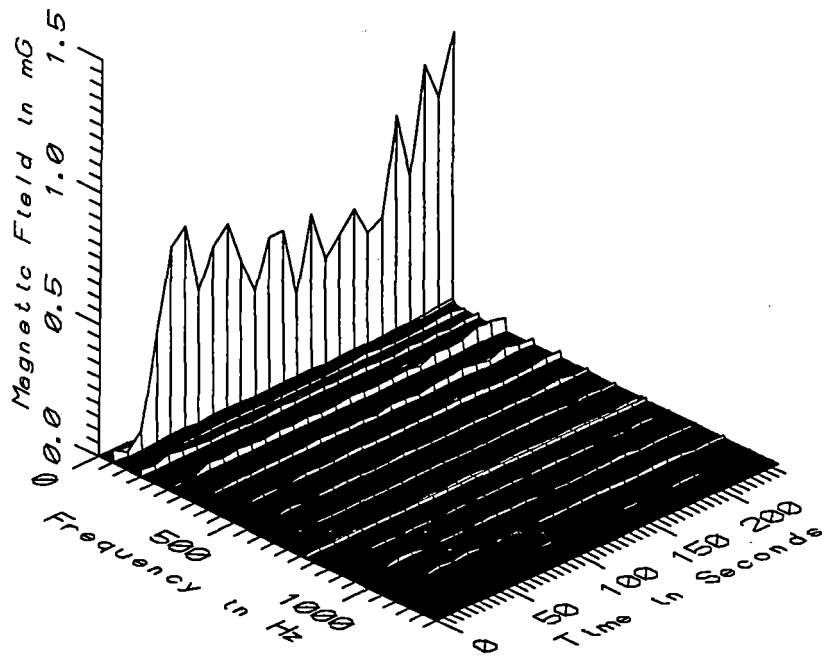

TGV032 - REFERENCE PROBE - 15m BEHIND STAFF, GAULT ST. DENIS SUBSTATION

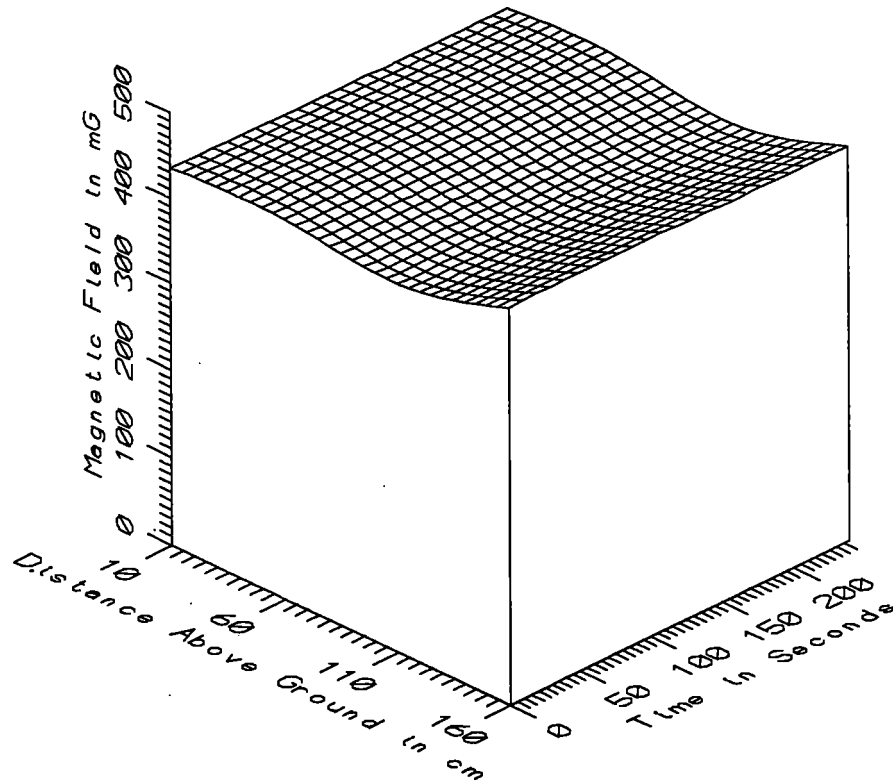

TGV032 - NEAR FENCE OF GAULT ST. DENIS SUBSTATION - STATIC

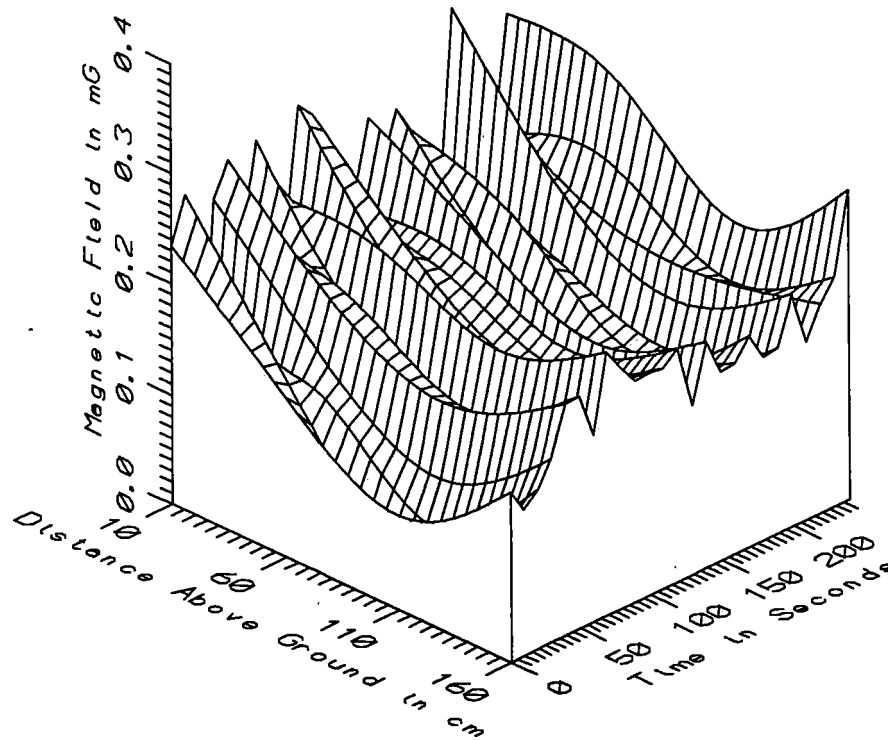

TGV032 - NEAR FENCE OF GAULT ST. DENIS SUBSTATION - LOW FREQ, 5-45Hz



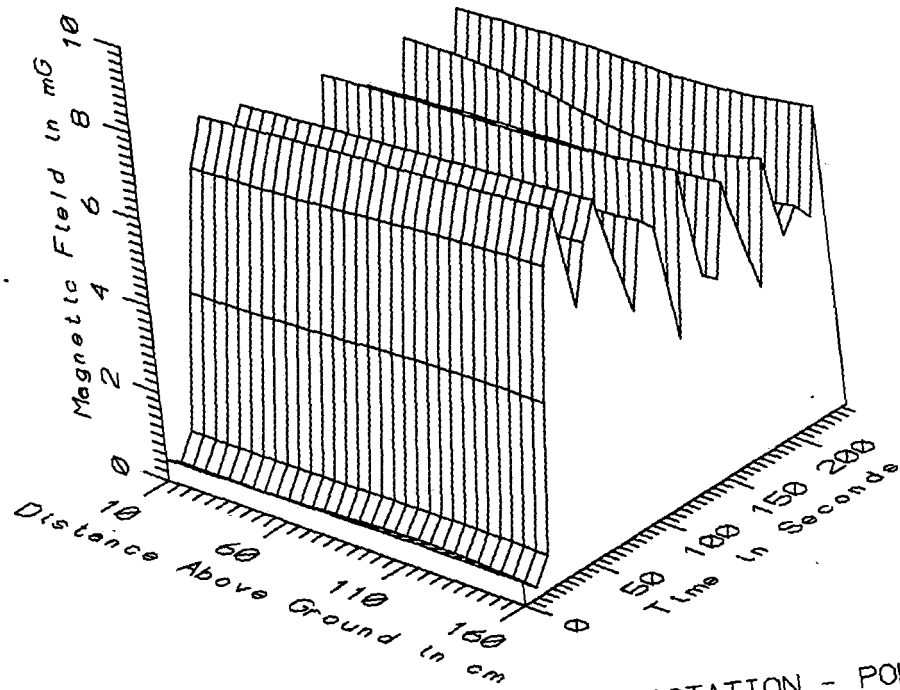

TGV032 - NEAR FENCE OF GAULT ST. DENIS SUBSTATION - POWER FREQ, 50-60Hz

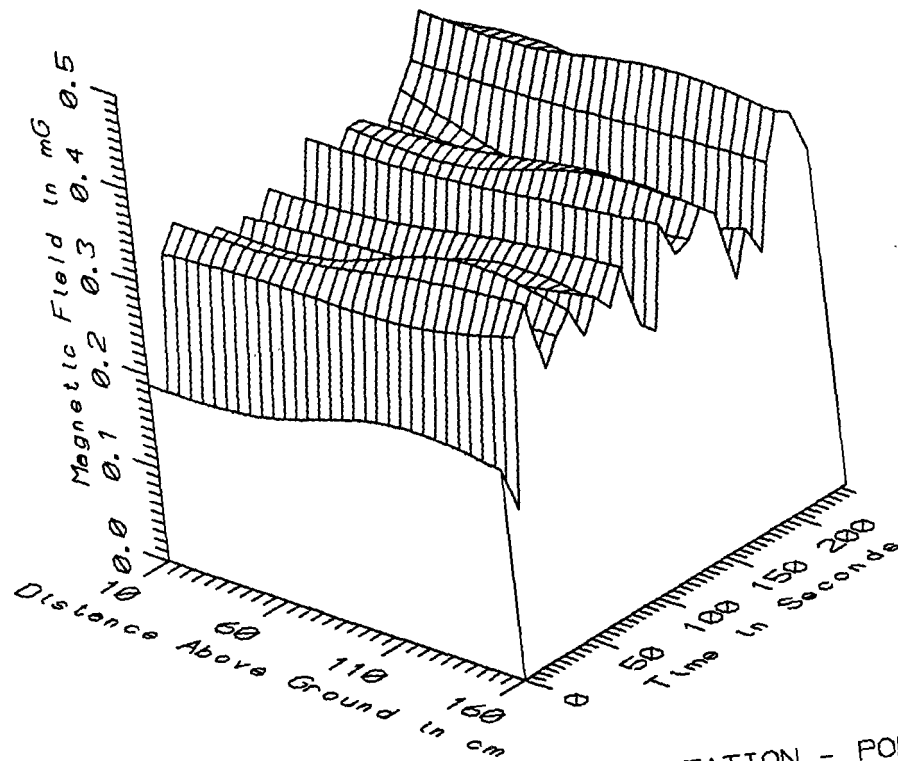

TGV032 - NEAR FENCE OF GAULT ST. DENIS SUBSTATION - POWER HARM, 65-300Hz

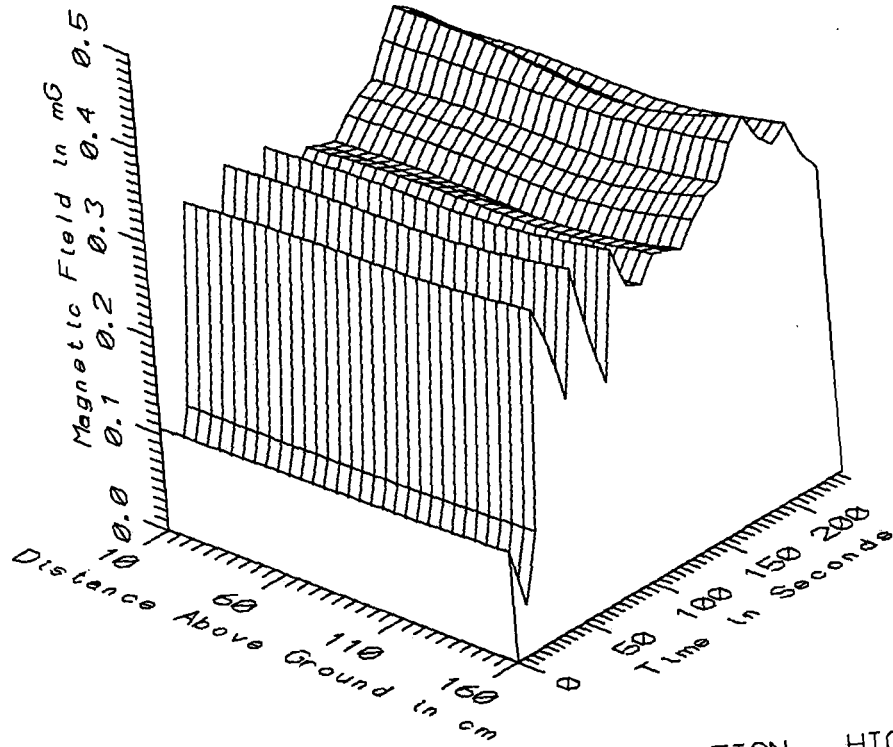

TGV032 - NEAR FENCE OF GAULT ST. DENIS SUBSTATION - HIGH FREQ, 305-2560Hz

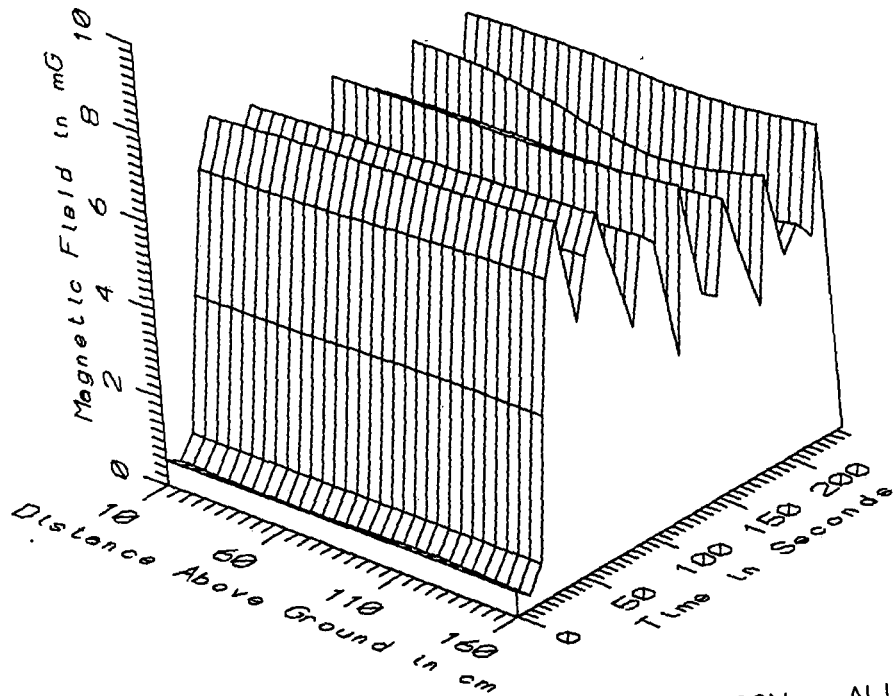

TGV032 - NEAR FENCE OF GAULT ST. DENIS SUBSTATION - ALL FREQ, 5-2560Hz

TGV032 - BEHIND GAULT ST. DENIS SUBSTATION				TOTAL OF 25 SAMPLES		
FREQUENCY BAND	HEIGHT ABOVE GROUND (cm)	MINIMUM MAGNETIC FIELD (mG)	MAXIMUM MAGNETIC FIELD (mG)	AVERAGE MAGNETIC FIELD (mG)	STANDARD DEVIATION (mG)	COEFFICIENT OF VARIATION (%)
STATIC	10	434.47	435.57	435.04	0.28	0.06
	60	436.67	437.60	437.19	0.20	0.05
	110	420.81	422.45	421.45	0.45	0.11
	160	455.48	457.26	456.54	0.46	0.10
5-45Hz LOW FREQ	10	0.10	0.33	0.24	0.05	22.63
	60	0.13	0.28	0.18	0.03	17.85
	110	0.04	0.20	0.14	0.04	27.76
	160	0.13	0.28	0.19	0.03	16.97
50-60Hz PWR FREQ	10	0.22	7.43	4.72	1.98	41.97
	60	0.22	7.68	4.81	2.04	42.34
	110	0.34	7.87	4.86	2.07	42.60
	160	0.22	8.10	5.07	2.15	42.32
65-300Hz PWR HARM	10	0.13	0.40	0.29	0.06	19.30
	60	0.15	0.40	0.30	0.06	18.45
	110	0.19	0.42	0.32	0.05	16.80
	160	0.18	0.42	0.33	0.05	16.38
305-2560Hz HIGH FREQ	10	0.05	0.39	0.28	0.09	30.34
	60	0.05	0.39	0.29	0.09	29.96
	110	0.05	0.38	0.29	0.09	29.57
	160	0.05	0.41	0.30	0.09	29.77
5-2560Hz ALL FREQ	10	0.38	7.45	4.76	1.95	41.08
	60	0.30	7.69	4.84	2.02	41.69
	110	0.40	7.88	4.88	2.05	42.04
	160	0.32	8.12	5.11	2.12	41.59

APPENDIX AH

DATASET TGV033  
BEHIND GAULT ST. DENIS SUBSTATION

Measurement Setup Code:      Staff: 35      Reference: 36  
   Drawing: A-10

Vehicle Status:                      Double train set to Paris passed  
   94 seconds into record

Measurement Date:                      September 9, 1992

Measurement Time:                      Start:      15:25:06  
   End:        15:28:10

Number of Samples:                      19

Programmed Sample Interval:      10 sec

Actual Sample Interval:                10.2 sec

Frequency Spectrum Parameters

<u>Probe Type:</u>	<u>Wideband</u>	<u>Static</u>
Maximum Frequency (Hz)	2560	64
Minimum Frequency (Hz)	5	0
Spectral Bandwidth (Hz)	5	1

Missing or Suspect Data:      None

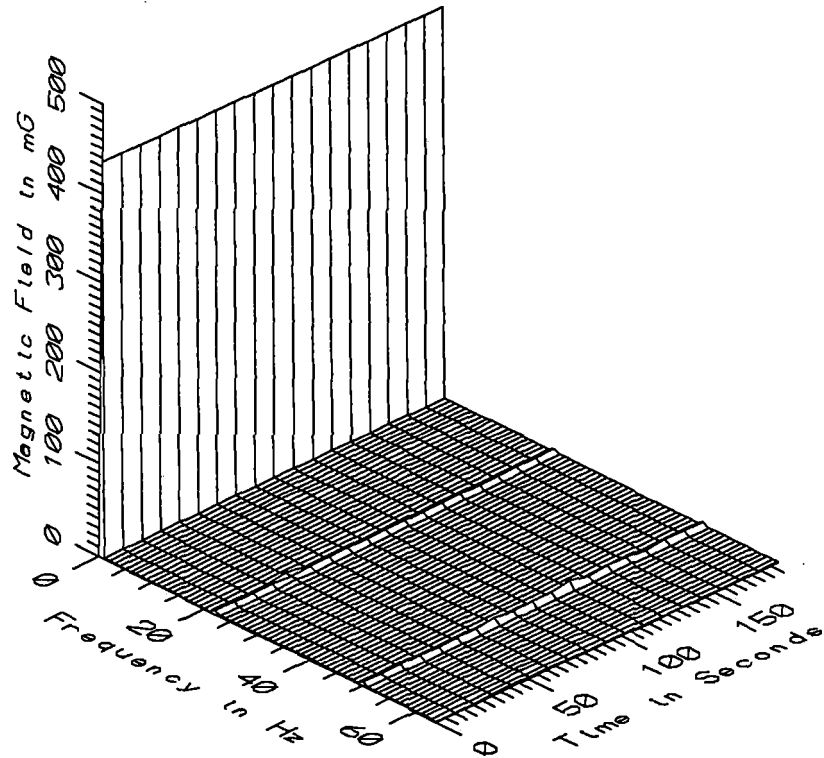

TGV033 - 10cm ABOVE GROUND NEAR FENCE OF GAULT ST. DENIS SUBSTATION

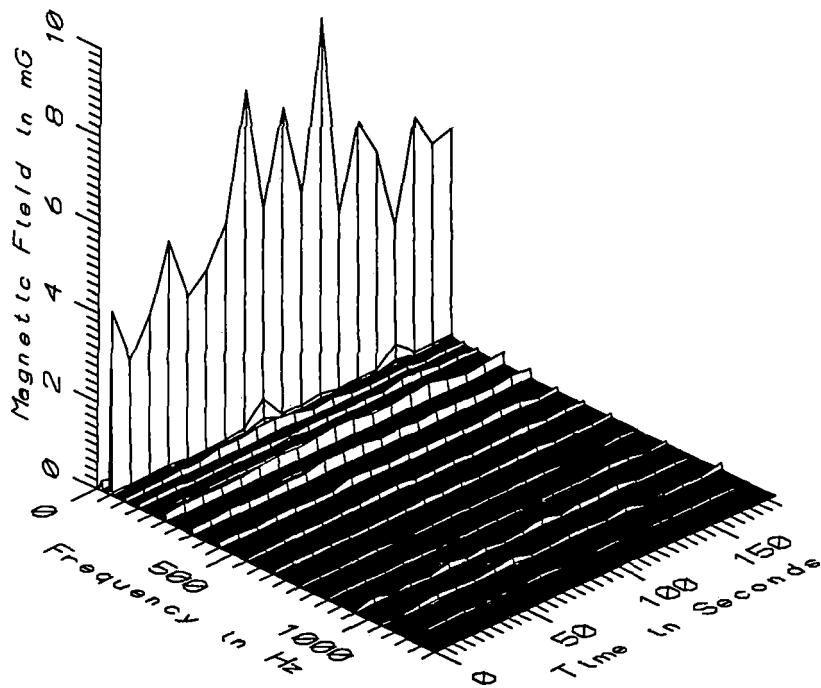

TGV033 - 10cm ABOVE GROUND NEAR FENCE OF GAULT ST. DENIS SUBSTATION

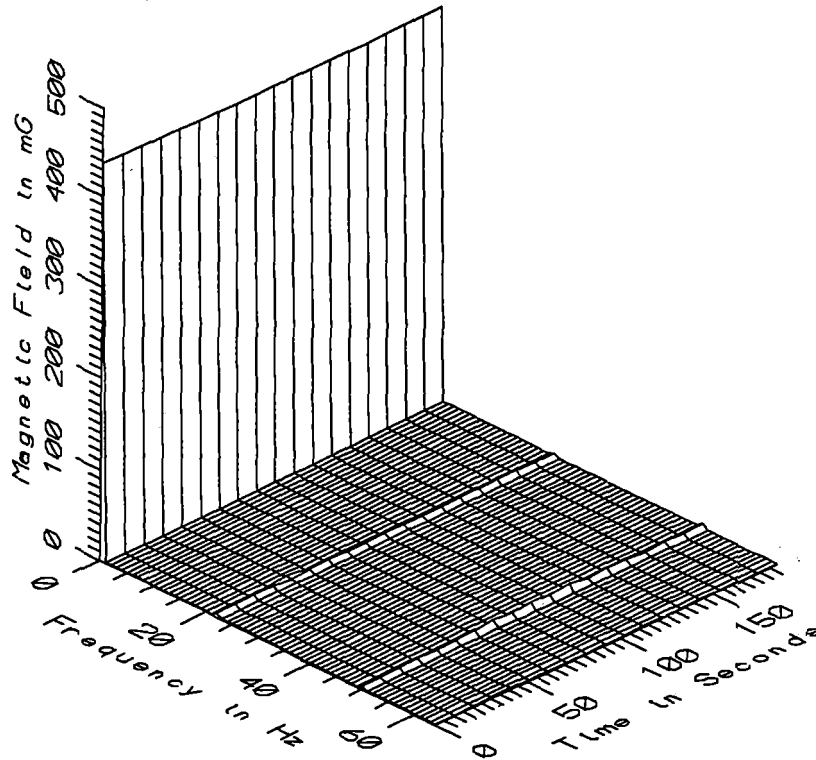

TGV033 - 60cm ABOVE GROUND NEAR FENCE OF GAULT ST. DENIS SUBSTATION

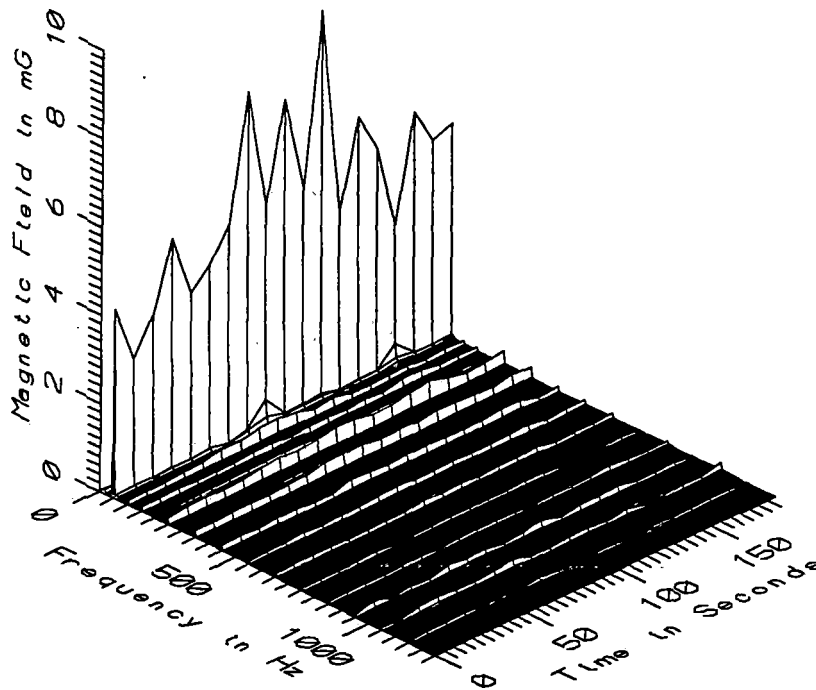

TGV033 - 60cm ABOVE GROUND NEAR FENCE OF GAULT ST. DENIS SUBSTATION

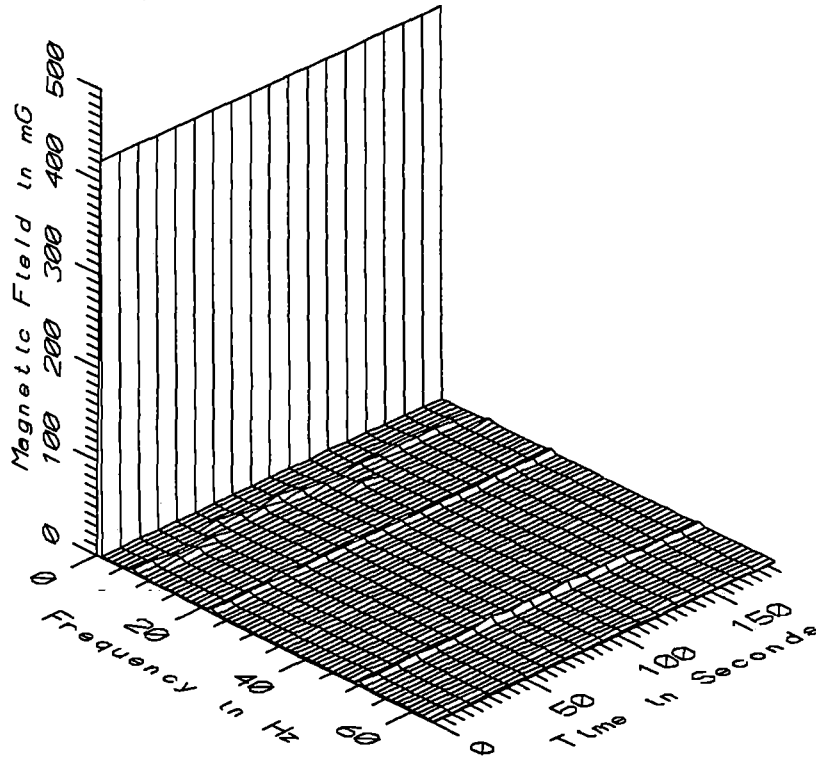

TGV033 - 110cm ABOVE GROUND NEAR FENCE OF GAULT ST. DENIS SUBSTATION

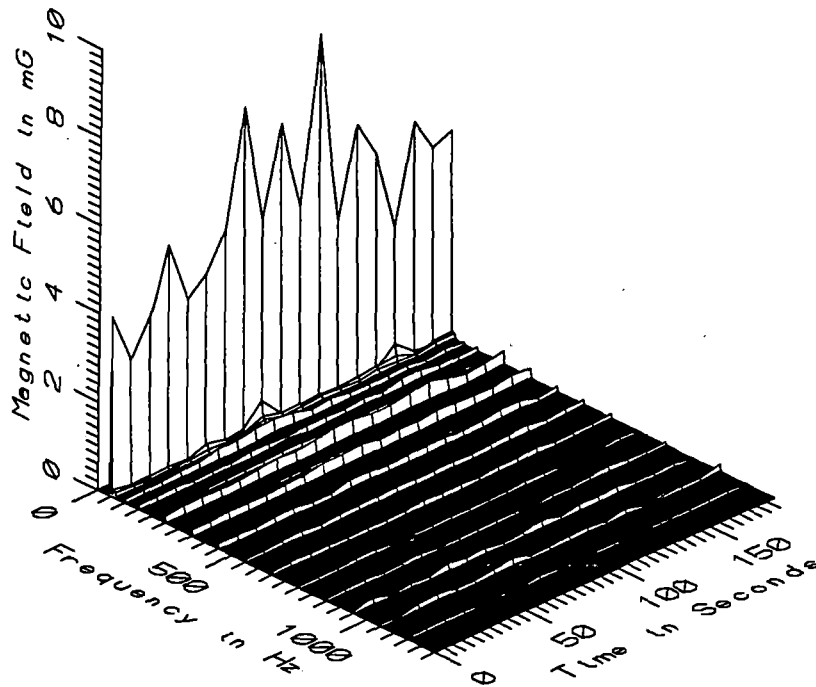

TGV033 - 110cm ABOVE GROUND NEAR FENCE OF GAULT ST. DENIS SUBSTATION

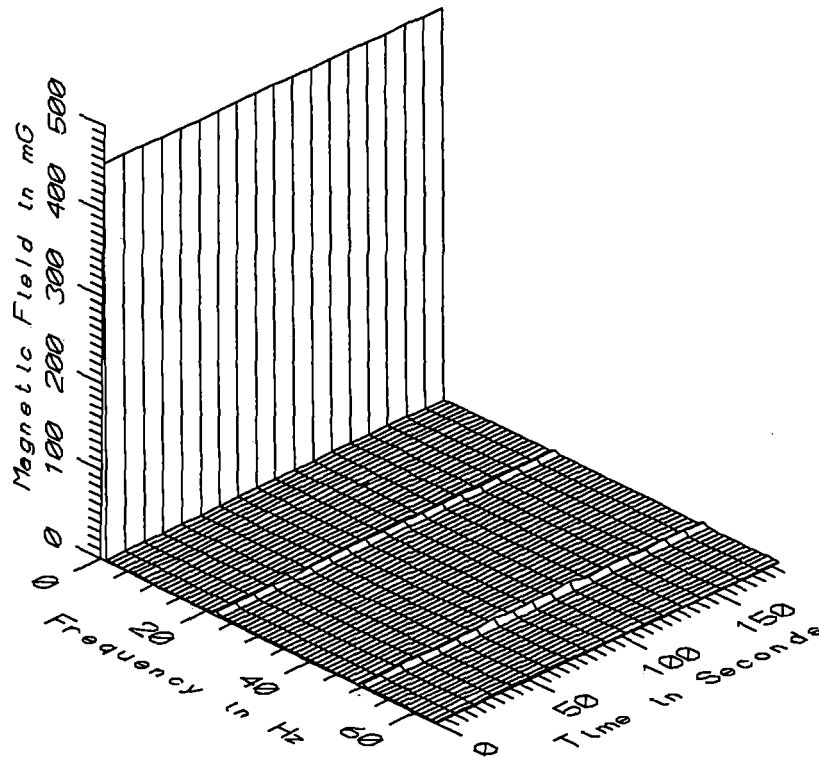

TGV033 - 160cm ABOVE GROUND NEAR FENCE OF GAULT ST. DENIS SUBSTATION

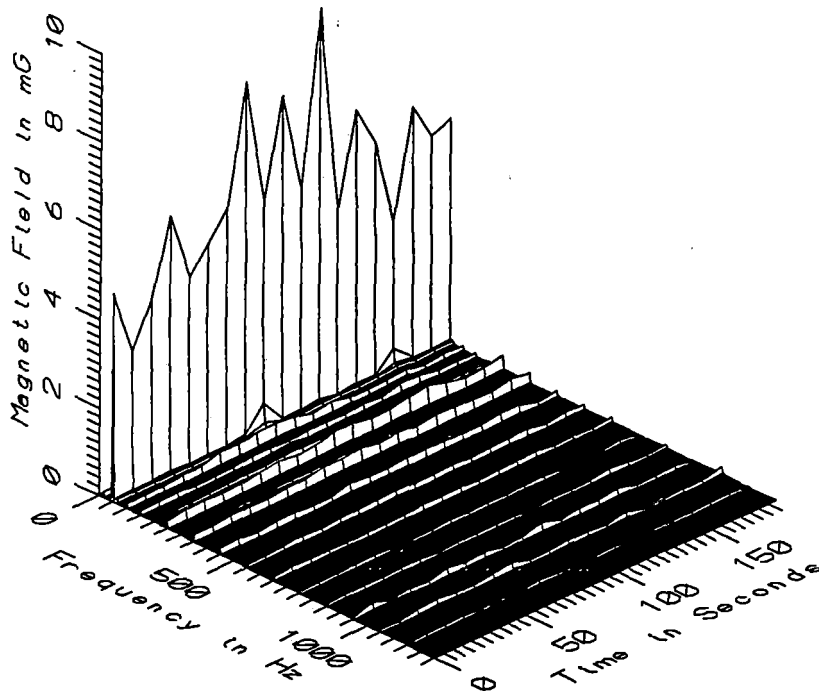

TGV033 - 160cm ABOVE GROUND NEAR FENCE OF GAULT ST. DENIS SUBSTATION



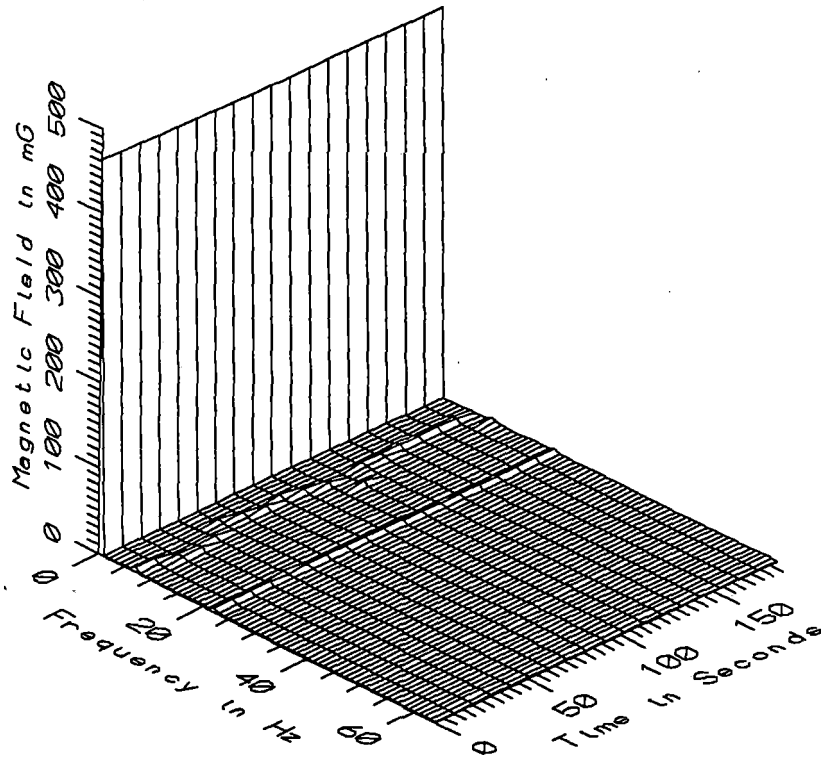

TGV033 - REFERENCE PROBE - 15m BEHIND STAFF, GAULT ST. DENIS SUBSTATION

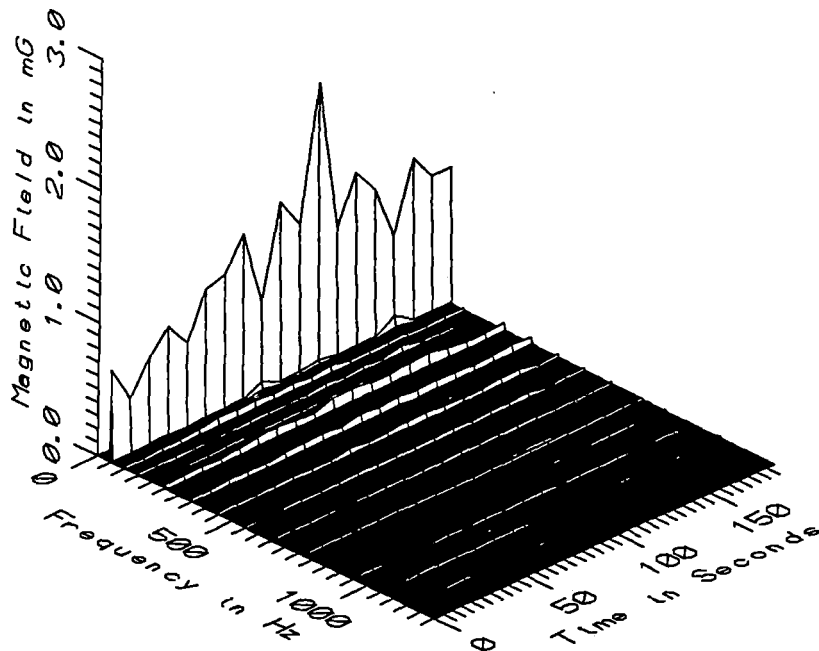

TGV033 - REFERENCE PROBE - 15m BEHIND STAFF, GAULT ST. DENIS SUBSTATION

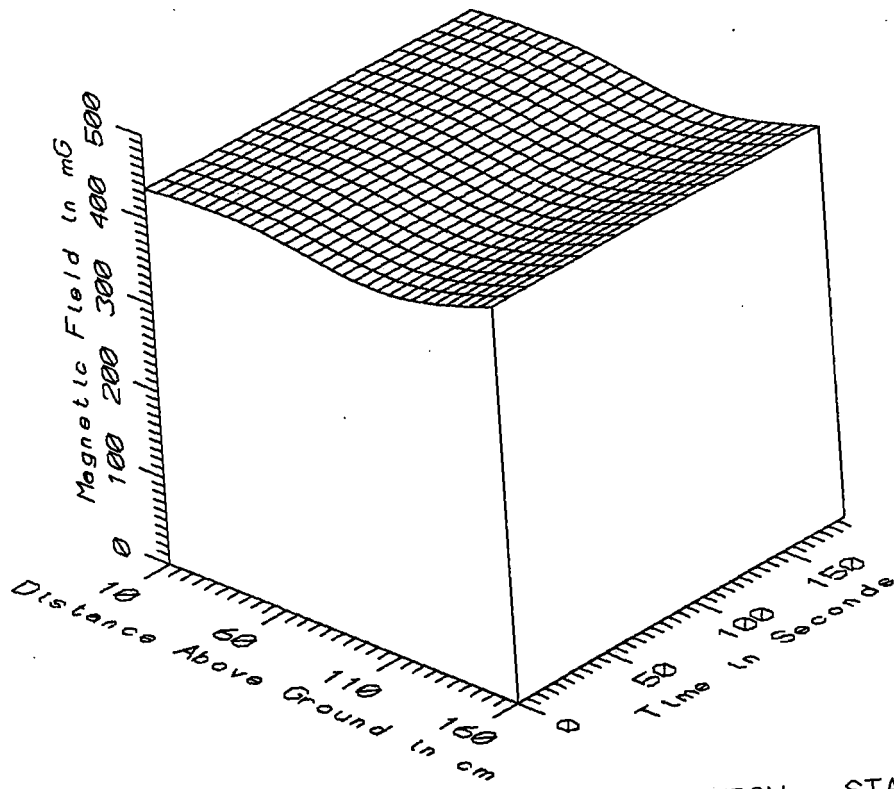

TGV033 - NEAR FENCE OF GAULT ST. DENIS SUBSTATION - STATIC

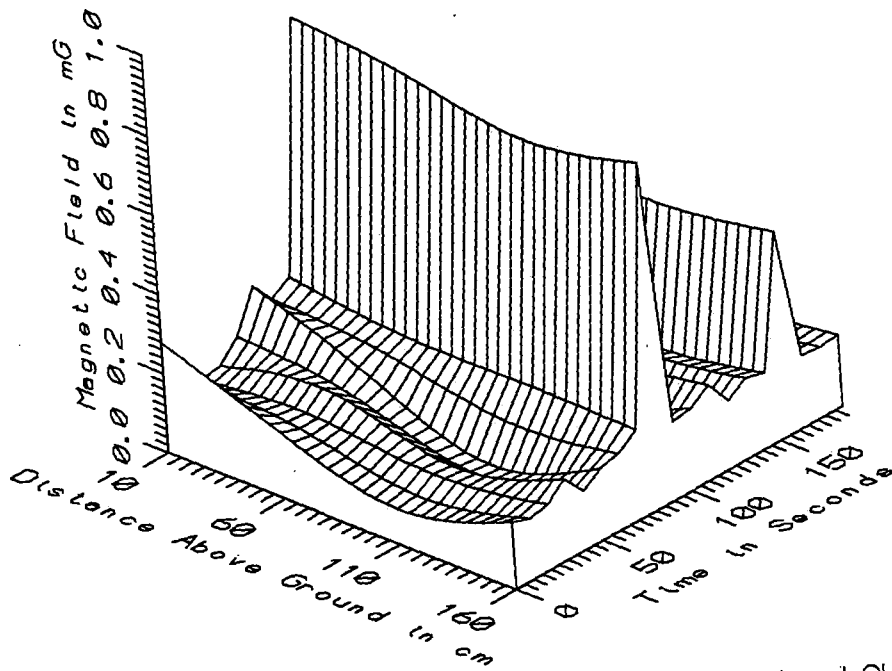

TGV033 - NEAR FENCE OF GAULT ST. DENIS SUBSTATION - LOW FREQ. 5-45Hz

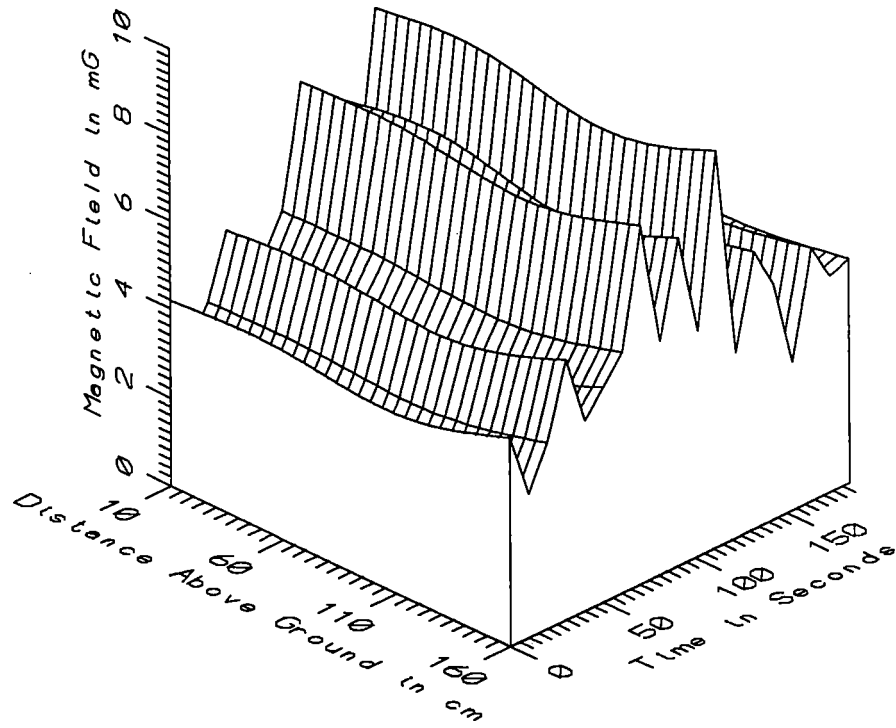

TGV033 - NEAR FENCE OF GAULT ST. DENIS SUBSTATION - POWER FREQ, 50-60Hz

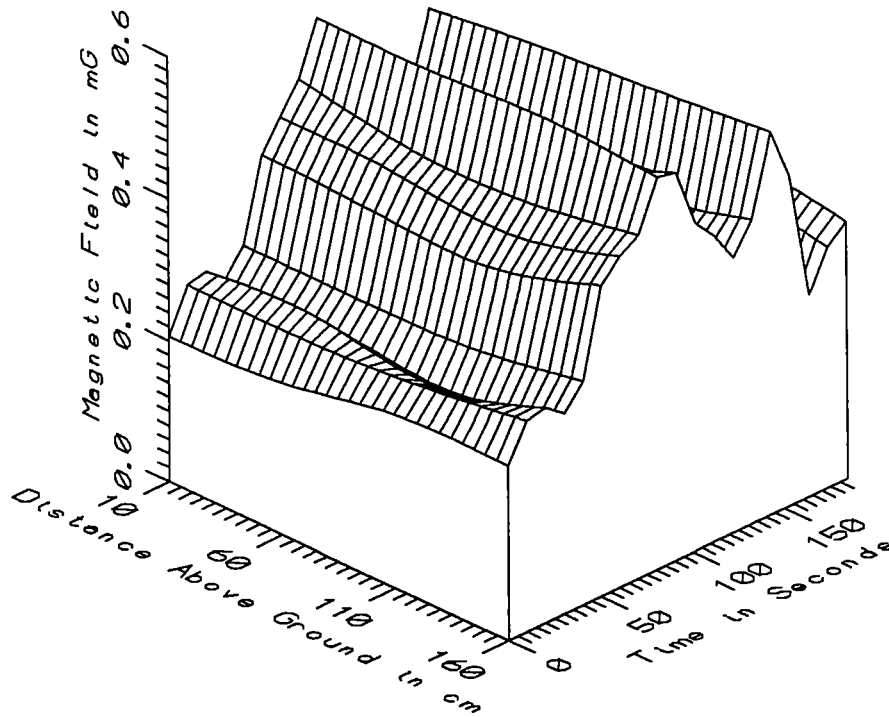

TGV033 - NEAR FENCE OF GAULT ST. DENIS SUBSTATION - POWER HARM, 65-300Hz

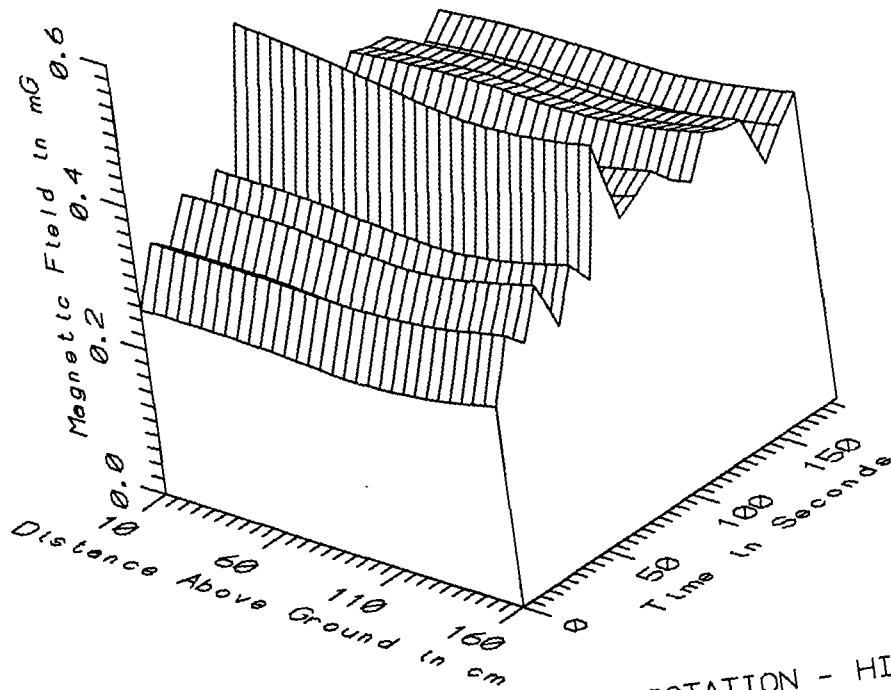

TGV033 - NEAR FENCE OF GAULT ST. DENIS SUBSTATION - HIGH FREQ, 305-2560Hz

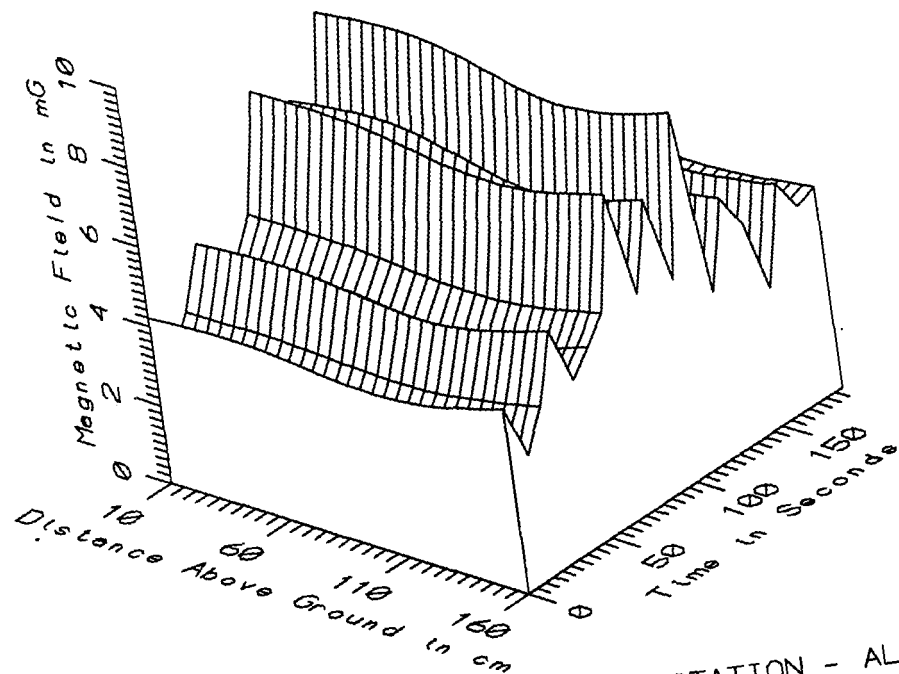

TGV033 - NEAR FENCE OF GAULT ST. DENIS SUBSTATION - ALL FREQ, 5-2560Hz

TGV033 - BEHIND GAULT ST. DENIS SUBSTATION				TOTAL OF 19 SAMPLES		
FREQUENCY BAND	HEIGHT ABOVE GROUND (cm)	MINIMUM MAGNETIC FIELD (mG)	MAXIMUM MAGNETIC FIELD (mG)	AVERAGE MAGNETIC FIELD (mG)	STANDARD DEVIATION (mG)	COEFFICIENT OF VARIATION (%)
STATIC	10	435.01	435.64	435.40	0.17	0.04
	60	437.48	438.37	437.95	0.24	0.05
	110	421.85	423.42	422.53	0.39	0.09
	160	455.44	457.95	456.68	0.62	0.14
5-45Hz LOW FREQ	10	0.13	0.89	0.28	0.17	60.89
	60	0.15	0.86	0.23	0.17	71.96
	110	0.08	0.82	0.19	0.18	94.97
	160	0.15	0.87	0.24	0.17	71.67
50-60Hz PWR FREQ	10	2.90	8.69	5.00	1.49	29.80
	60	2.95	8.83	5.09	1.50	29.50
	110	2.89	8.29	4.87	1.40	28.66
	160	3.25	8.99	5.38	1.48	27.48
65-300Hz PWR HARM	10	0.21	0.55	0.37	0.10	27.45
	60	0.22	0.55	0.38	0.10	26.47
	110	0.24	0.56	0.38	0.10	25.26
	160	0.25	0.55	0.40	0.10	23.95
305-2560Hz HIGH FREQ	10	0.26	0.55	0.37	0.06	16.59
	60	0.25	0.53	0.38	0.06	15.90
	110	0.25	0.51	0.37	0.06	15.47
	160	0.28	0.53	0.40	0.06	14.00
5-2560Hz ALL FREQ	10	2.94	8.71	5.04	1.49	29.45
	60	2.99	8.85	5.13	1.50	29.18
	110	2.93	8.31	4.91	1.39	28.33
	160	3.28	9.01	5.42	1.47	27.15

APPENDIX AI

DATASET TGV034  
INSIDE CONTROL HOUSE AT GAULT ST. DENIS SUBSTATION

Measurement Setup Code:           Staff: 37           Reference: 38  
  Drawing: A-10

Vehicle Status:                    Single train set from Paris passed  
  324 seconds into record, single  
  train set to Paris passed 588  
  seconds into record

Measurement Date:                 September 9, 1992

Measurement Time:                 Start:     15:43:06  
  End:       15:55:33

Number of Samples:                 68

Programmed Sample Interval:       10 sec

Actual Sample Interval:            11.1 sec

Frequency Spectrum Parameters

<u>Probe Type:</u>	<u>Wideband</u>	<u>Static</u>
Maximum Frequency (Hz)	2560	64
Minimum Frequency (Hz)	5	0
Spectral Bandwidth (Hz)	5	1

Missing or Suspect Data:           60 cm sensor malfunctioned during  
  record

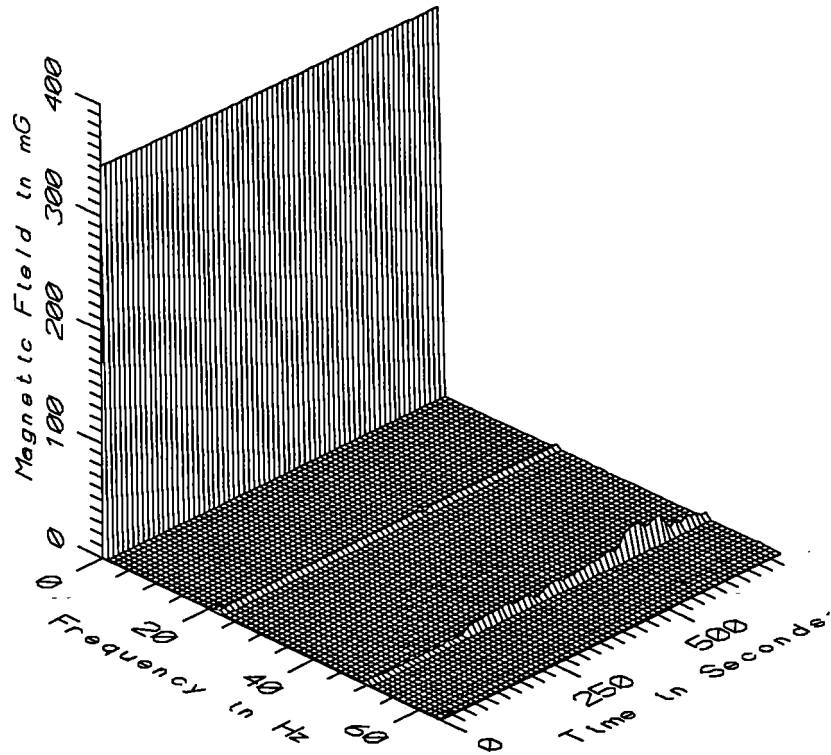

TGV034 - 10cm ABOVE FLOOR IN CONTROL HOUSE, GAULT ST. DENIS SUBSTATION

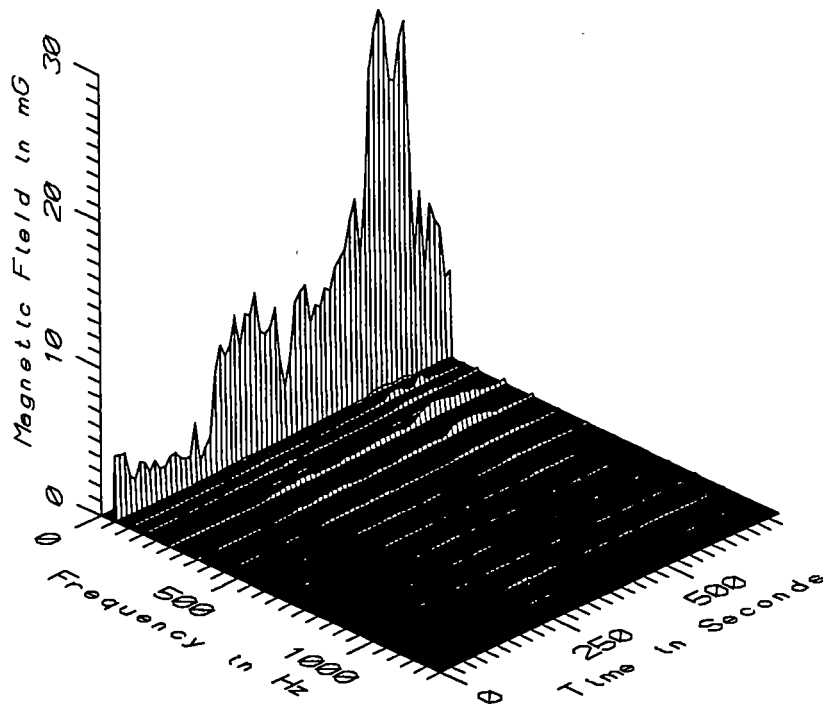

TGV034 - 10cm ABOVE FLOOR IN CONTROL HOUSE, GAULT ST. DENIS SUBSTATION

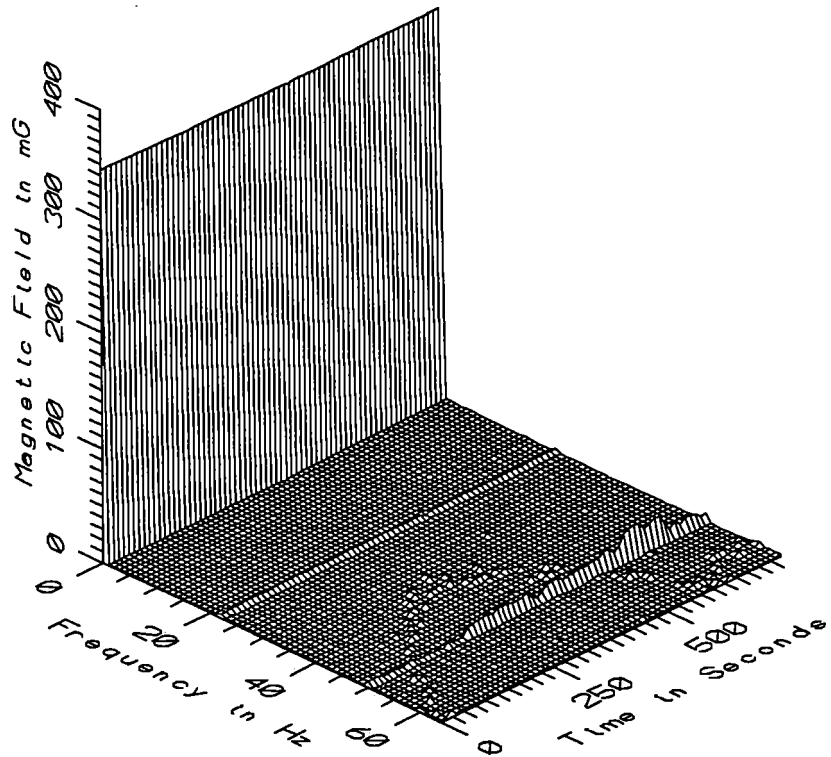

TGV034 - 110cm ABOVE FLOOR IN CONTROL HOUSE, GAULT ST. DENIS SUBSTATION

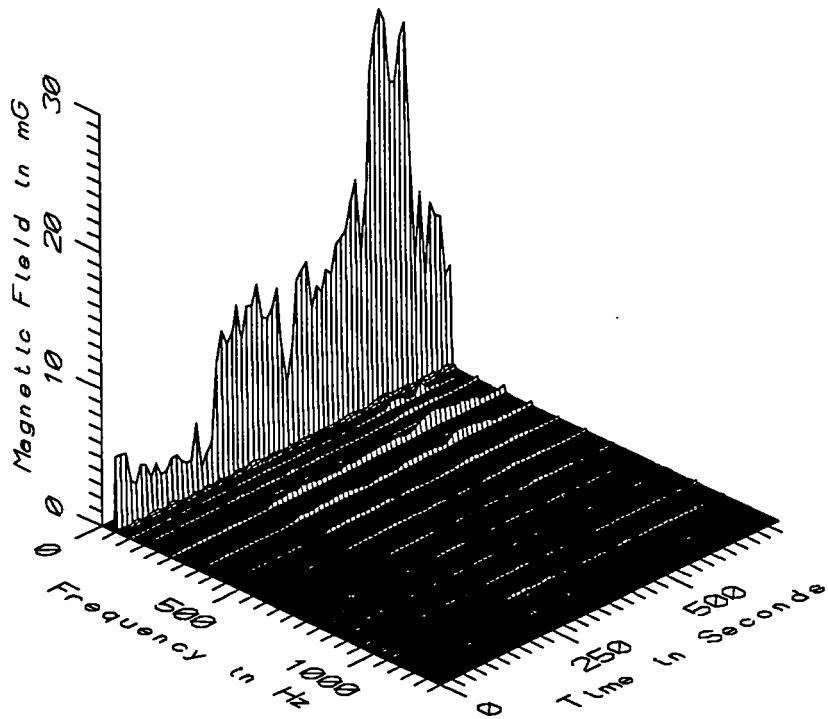

TGV034 - 110cm ABOVE FLOOR IN CONTROL HOUSE, GAULT ST. DENIS SUBSTATION



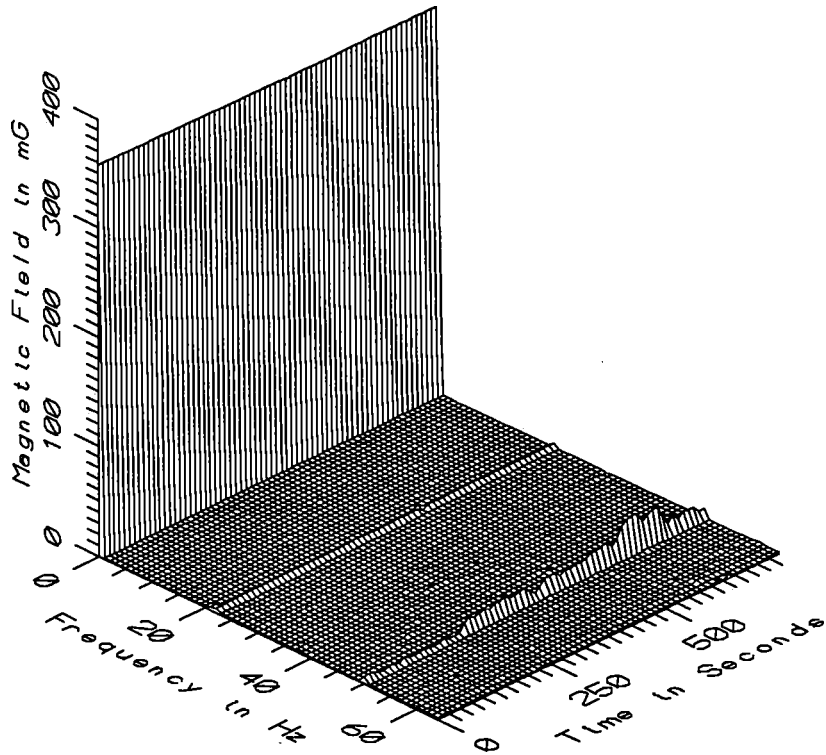

TGV034 - 160cm ABOVE FLOOR IN CONTROL HOUSE, GAULT ST. DENIS SUBSTATION

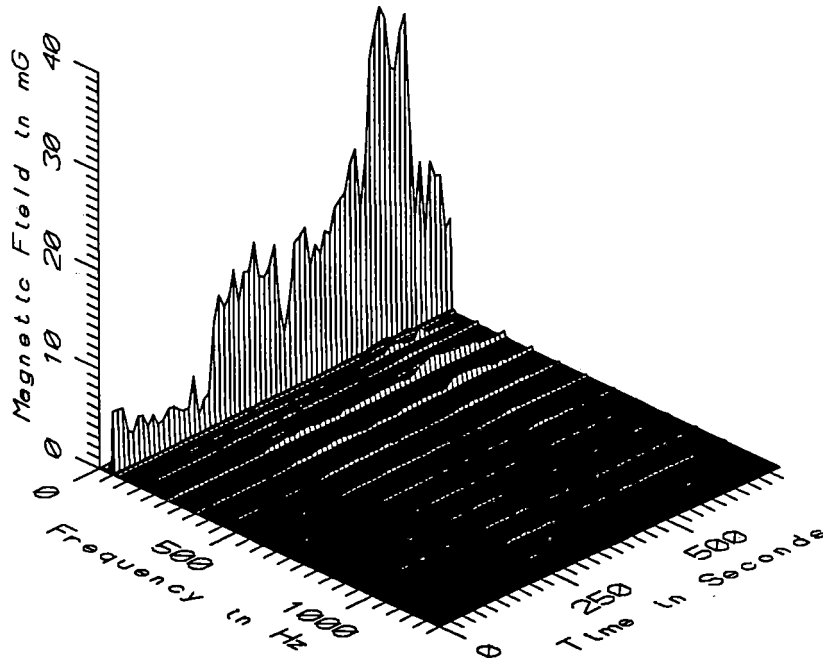

TGV034 - 160cm ABOVE FLOOR IN CONTROL HOUSE, GAULT ST. DENIS SUBSTATION

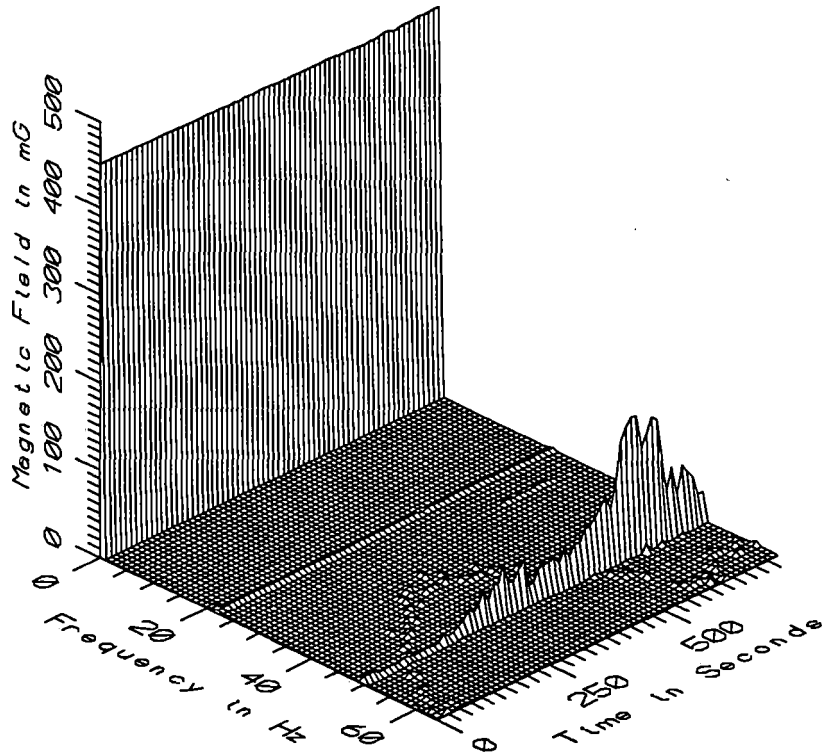

TGV034 - REF. PROBE - OUTSIDE CONTROL HOUSE, GAULT ST. DENIS SUBSTATION

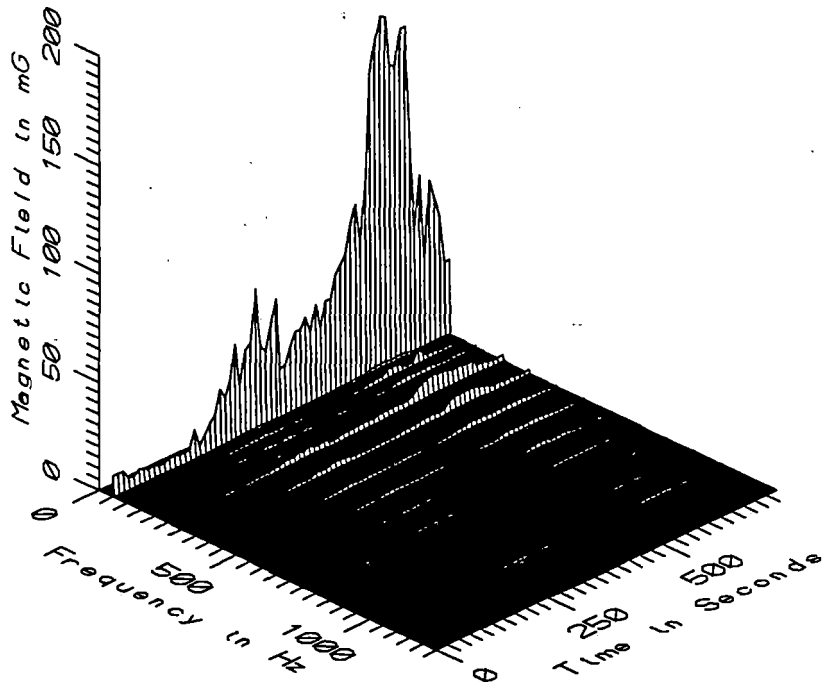

TGV034 - REF. PROBE - OUTSIDE CONTROL HOUSE, GAULT ST. DENIS SUBSTATION

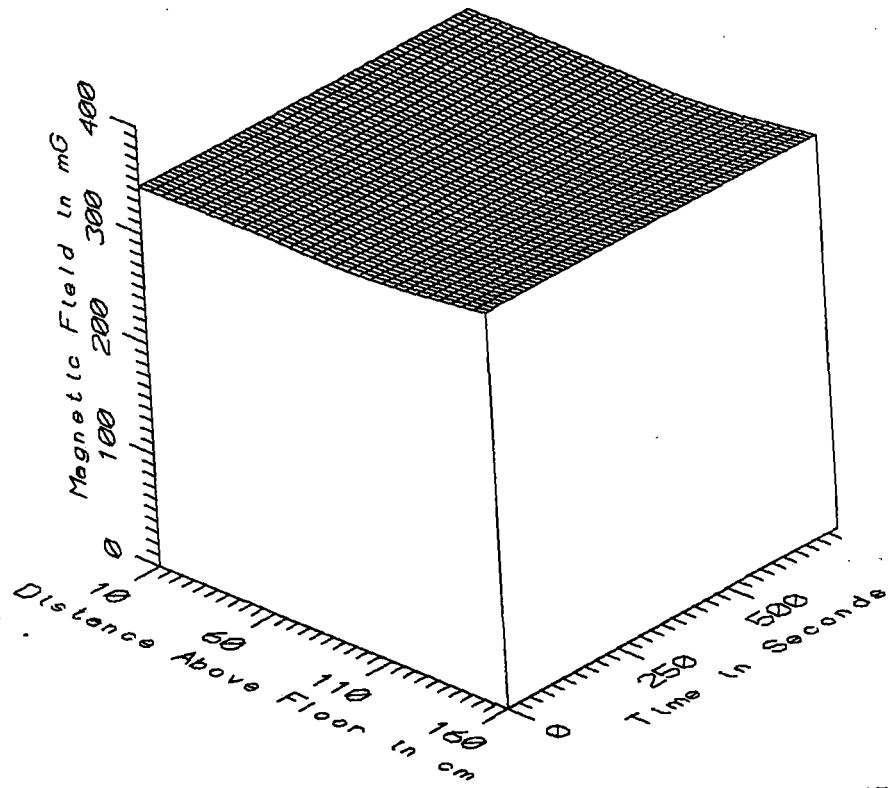

TGV034 - IN CONTROL HOUSE, GAULT ST. DENIS SUB. - STATIC

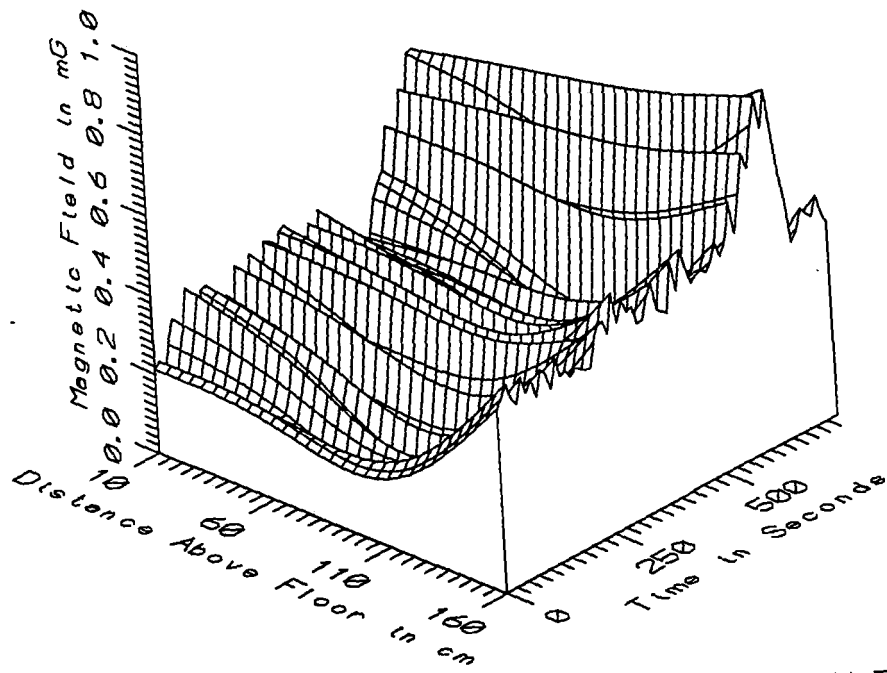

TGV034 - IN CONTROL HOUSE, GAULT ST. DENIS SUB. - LOW FREQ, 5-45Hz

TGV034 - IN CONTROL HOUSE, GAULT ST. DENIS SUB. - POWER HARM. 65-300Hz

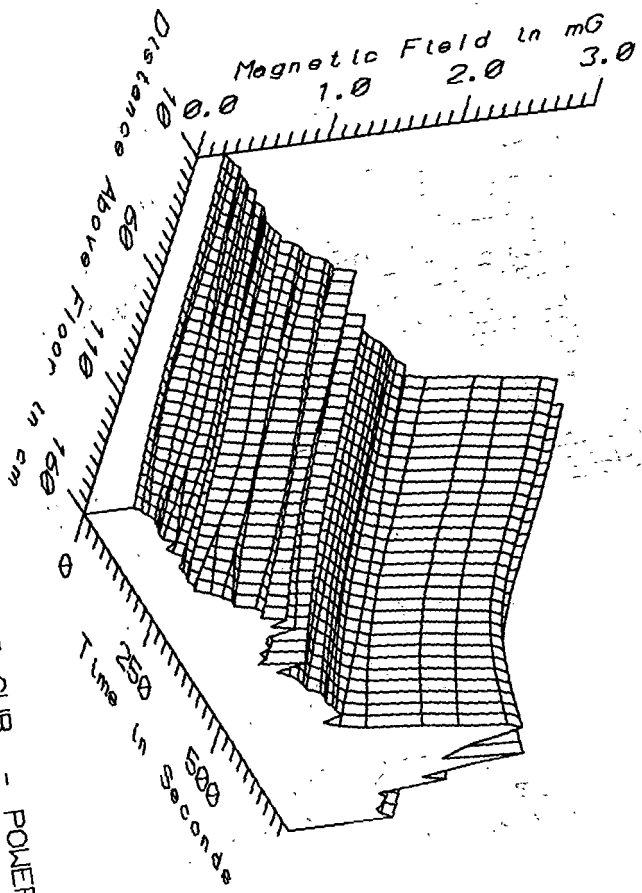

TGV034 - IN CONTROL HOUSE, GAULT ST. DENIS SUB. - POWER FREQ. 50-60Hz

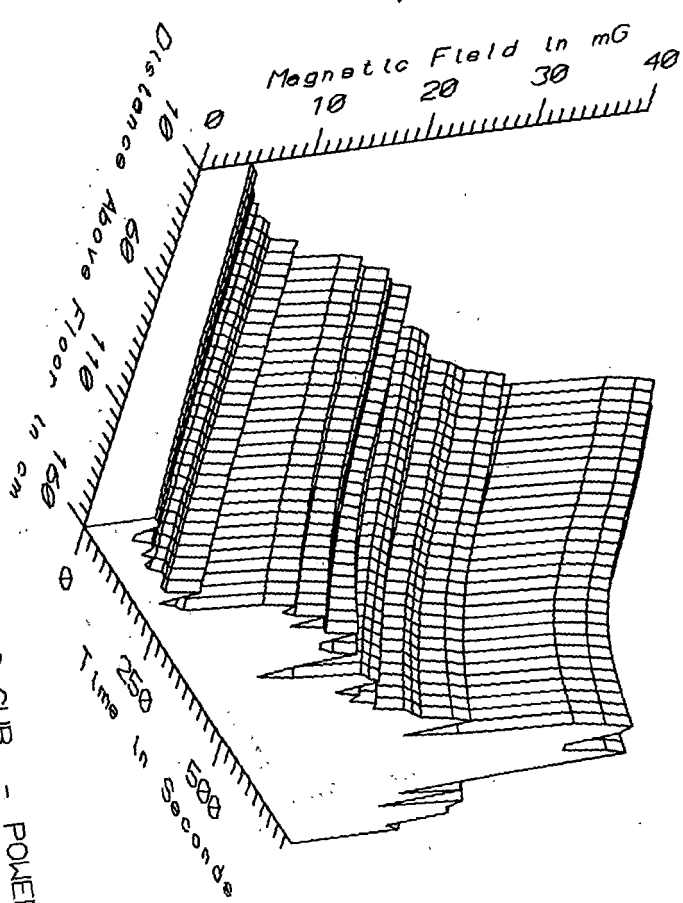



...magnetic and Electric Field  
...of the French Train  
(TGV-A) Rail System  
...Research and Man-  
...Advanced Systems

Final Report on Magnetic and Electric Field Testing  
of the French Testing of the French Train A Grande  
Vitesse-Atlantique (TGV-A) Rail System, Volume II-  
Appendices, Electric Research and Management,  
Inc, 1993 -11-Advanced Systems

PROPERTY OF FRA  
RESEARCH & DEVELOPMENT  
LIBRARY

---

---

*For More Information, Contact:*

**ELECTRIC RESEARCH AND MANAGEMENT, INC.**

P.O. Box 165 • State College, PA 16804  
Telephone (814) 466-3031 • Facsimile (814) 466-2393

6630 Highway 9, Suite 203 • Felton, CA 95018  
Telephone (408) 335-9061 • Facsimile (408) 335-9065

---

---