



U.S. Department
of Transportation
Federal Railroad
Administration

EVALUATION OF ALTERNATIVE DETECTION TECHNOLOGIES FOR TRAINS AND HIGHWAY VEHICLES AT HIGHWAY RAIL INTERSECTIONS

Office of Research and
Development
Washington, D.C. 20590

DOT/FRA/ORD-

October 2000
Final Report

This document is available to the
U.S. public through the National
Technical Information Service
Springfield, Virginia 22161

Disclaimer: This document is disseminated under the sponsorship of the Department of Transportation in the interest of information exchange. The United States Government assumes no liability for the contents or use thereof. The United States Government does not endorse products or manufacturers. Trade or manufacturers' names appear herein solely because they are considered essential to the object of this report.

Approximate Conversions to Metric Measures

Symbol	When You Know	Multiply by	To Find	Symbol
LENGTH				
in	inches	*2.50	centimeters	cm
ft	feet	30.00	centimeters	cm
yd	yards	0.90	meters	m
mi	miles	1.60	kilometers	km

AREA

in ²	square inches	6.50	square centimeters	cm ²
ft ²	square feet	0.09	square meters	m ²
yd ²	square yards	0.80	square meters	m ²
mi ²	square miles	2.60	square kilometers	km ²
	acres	0.40	hectares	ha

MASS (weight)

oz	ounces	28.00	grams	g
lb	pounds	0.45	kilograms	kg
	short tons (2000 lb)	0.90	tonnes	t

VOLUME

tsp	teaspoons	5.00	milliliters	ml
Tbsp	tablespoons	15.00	milliliters	ml
fl oz	fluid ounces	30.00	milliliters	ml
c	cups	0.24	liters	l
pt	pints	0.47	liters	l
qt	quarts	0.95	liters	l
gal	gallons	3.80	liters	l
ft ³	cubic feet	0.03	cubic meters	m ³
yd ³	cubic yards	0.76	cubic meters	m ³

TEMPERATURE (exact)

'F	Fahrenheit temperature	5/9 (after subtracting 32)	Celsius temperature	'C
----	------------------------	----------------------------	---------------------	----

METRIC CONVERSION FACTORS

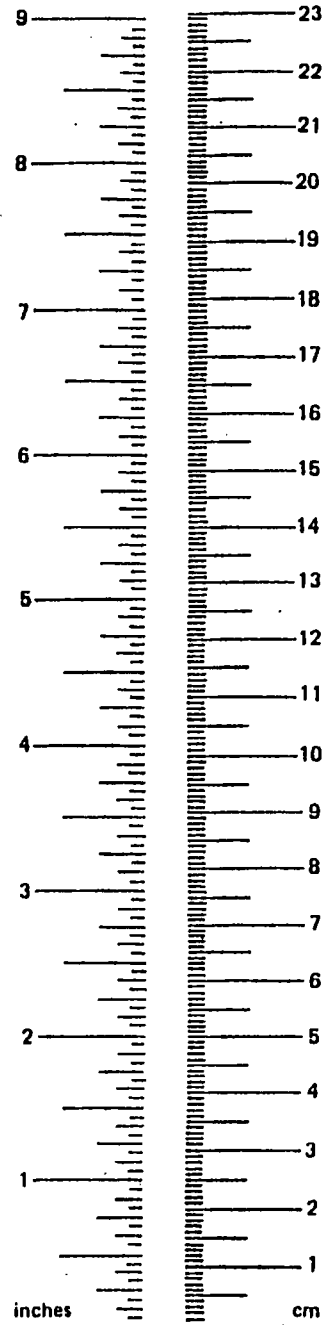

Approximate Conversions from Metric Measures

Symbol	When You Know	Multiply by	To Find	Symbol
LENGTH				
mm	millimeters	0.04	inches	in
cm	centimeters	0.40	inches	in
m	meters	3.30	feet	ft
m	meters	1.10	yards	yd
km	kilometers	0.60	miles	mi

AREA

cm ²	square centim.	0.16	square inches	in ²
m ²	square meters	1.20	square yards	yd ²
km ²	square kilom.	0.40	square miles	mi ²
ha	hectares (10,000 m ²)	2.50	acres	

MASS (weight)

g	grams	0.035	ounces	oz
kg	kilograms	2.2	pounds	lb
t	tonnes (1000 kg)	1.1	short tons	

VOLUME

ml	milliliters	0.03	fluid ounces	fl oz
l	liters	2.10	pints	pt
l	liters	1.06	quarts	qt
l	liters	0.26	gallons	gal
m ³	cubic meters	36.00	cubic feet	ft ³
m ³	cubic meters	1.30	cubic yards	yd ³

TEMPERATURE (exact)

'C	Celsius* temperature	9/5 (then add 32)	Fahrenheit temperature	'F
----	----------------------	-------------------	------------------------	----

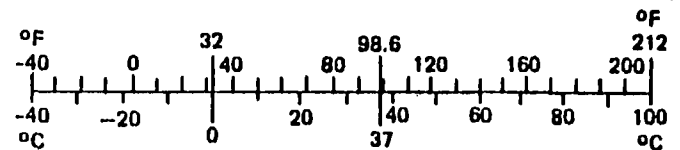

* 1 in. = 2.54 cm (exactly)

(blank)

1. Report No. FRA		2. Government Accession No.		3. Recipient's Catalog No.	
4. Title and Subtitle Evaluation of Alternative Detection Technologies for Trains and Highway Vehicles at Highway Rail Intersections				5. Report Date October 2000	
				6. Performing Organization Code	
7. Authors Richard P. Reiff and Scott E. Gage				8. Performing Organization Report No.	
9. Performing Organization Name and Address Transportation Technology Center, Inc. P.O. Box 11130 Pueblo, CO 81001				10. Work Unit No. (TRAIS)	
				11. Contract or Grant No. DTFR53-93-C-00001 Task Order 123	
12. Sponsoring Agency Name and Address U.S. Department of Transportation Federal Railroad Administration Office of Research and Development 1120 Vermont Avenue, SW Washington, DC 20590				13. Type of Report or Period Covered October - November 1999	
				14. Sponsoring Agency Code FRA	
15. Supplemental Notes					
16. Abstract Under sponsorship from the Federal Railroad Administration (FRA), Transportation Technology Center, Inc. (TTCI) evaluated five technologies for their ability to detect trains and/or highway vehicles approaching and occupying highway rail intersections. TTCI evaluated the performance of these technologies during October and November 1999 at the FRA's Transportation Technology Center in Pueblo, Colorado, USA. Railroad track circuits are the most common method currently used by North American railroads to detect trains and control warning devices at a highway/railroad intersection (HRI). The new advanced warning systems, such as four quadrant gates and barriers at HRIs may require additional information on train and highway vehicle status to ensure optimal operation and safety. To address these issues, non-track circuit based technologies have been proposed as an alternative for controlling HRI warning devices. Some alternative technologies offer additional features which allow the detection of highway vehicles located within the HRI limits, which may further enhance crossing safety. This evaluation included the assessment of operational and detection capabilities of alternative technologies.					
17. Key Words Grade crossing warning, Highway rail intersection, Train detection, Highway Vehicle detection, Detection system(s), Loss of shunt, Intelligent traffic systems				18. Distribution Statement This document is available through National Technical Information Service, Springfield, VA 22161	
19. Security Classification (of the report)		20. Security Classification (of this page)		21. No. of Pages	22. Price

EXECUTIVE SUMMARY:

Under sponsorship from the Federal Railroad Administration (FRA), Transportation Technology Center, Inc. (TTCI) evaluated five technologies for their ability to detect trains and/or highway vehicles approaching and occupying highway rail intersections. TTCI evaluated the performance of these technologies in November 1999 at the FRA's Transportation Technology Center in Pueblo, Colorado, USA.

Railroad track circuits are the most common method currently used by North American railroads to detect trains and control warning devices at a highway/railroad intersection (HRI). The introduction of advanced warning systems, such as four quadrant gates and barriers at HRIs may require additional information on train and highway vehicle status to ensure optimal operation and safety. To address these issues, non-track circuit based technologies have been proposed as an alternative for controlling HRI warning devices. Some alternative technologies offer additional features which allow the detection of highway vehicles located within the HRI limits, which may further enhance crossing safety. This evaluation included the assessment of operational and detection capabilities of alternative technologies.

Previous work conducted under FRA Task Order 106 investigated the use of alternative train detection systems to supplement the operation of conventional track circuits at grade crossing islands. Many of these alternative detection systems used features of a full function grade crossing system, and in some cases had the capability to replace the complete track circuit. Recent interest for improved train and traffic information led to additional work in this area, which has been funded by Task Order 123.

The performance of the five detection systems representing the five technologies was evaluated against a set of guidelines and requirements prepared by an advisory committee made up of representatives from various federal agencies and railroads. Results suggest that most systems using these alternative detection technologies did not always interpret train and highway vehicle presence within prescribed limits. In some instances, differences were caused by placing sensors at or near detection limits used by conventional track circuit technologies. In revenue service applications, some sensor locations may be different.

The systems selected for evaluation used non track-circuit based sensor technologies placed at, near, and on the approach to the HRI. These systems, normally dual-technology systems, utilized various combinations of sensors including magnetic anomaly, vibration, wheel counters, low power laser, video imaging, inductive loops, radar, passive infrared, and ultrasonic devices. Connections between remote sensors and control systems used a number of hard wire or radio links for communicating information. Each of the five systems used proprietary software to interpret information from sensors and determine the approach, presence, and departure of a train and/or highway vehicle.

Results from these evaluations suggest that alternative systems can detect train and highway vehicles. However, differences between actual and detected occupancy were of such magnitude that additional product development and evaluation is warranted to ensure safe and reliable field operation.

Table of Contents

1.0 INTRODUCTION	1
2.0 BACKGROUND	1
3.0 TECHNICAL REQUEST FOR INFORMATION	2
3.1 SELECTION PROCESS	3
3.2 TEST CROSSING DESCRIPTION	4
4.0 SYSTEM DESCRIPTIONS	7
4.1 SYSTEM 1	7
4.1.1 Detailed System Description	8
4.1.1.1 Controller	9
4.1.1.2 Sensor Design	10
4.1.1.3 Power Supply	11
4.1.1.4 Antenna	11
4.1.1.5 Communication	11
4.2 SYSTEM 2	11
4.2.1 Detailed System Description	12
4.2.2 Description of System 2 Vehicle Detection: Theory of Operation ..	16
4.2.2.1 Components	17
4.2.2.2 3D Laser Scanner	17
4.2.2.3 3D-CCD IR Double Camera System	17
4.2.2.4 Combination	18
4.2.2.5 Software: Object Detection	18
4.2.2.6 Summary	18
4.3 SYSTEM 3	20
4.4 SYSTEM 4	20
4.4.1 System Operation	22
4.4.2 Train Detection	22
4.4.3 Test Arrangement	23
4.5 SYSTEM 5	24
4.6 SYSTEM 6	24
4.6.1 Detector Assemblies	24
4.6.2 Mounting of the Detectors	25
4.6.2.1 Detection Pattern on the HRI	26
4.6.3 3-D View of the HRI with Detectors Installed	27
4.6.4 Configuration of the System	27
4.6.5 Potential Applications	27
5.0 PROGRAM AND TEST PROTOCOL	28
5.1 TEST MATRIX	29

6.0 RESULTS OF TESTING.....	32
7.0 OBSERVATIONS FOR EACH SYSTEM.....	35
7.1 SYSTEM 1: TRAIN DETECTION ONLY.....	35
7.2 SYSTEM 2: TRAIN AND VEHICLE DETECTION.....	36
7.2.1 Train Detection.....	36
7.2.2 Vehicle Detection.....	36
7.3 SYSTEM 3: TRAIN DETECTION ONLY.....	37
7.4 SYSTEM 4: TRAIN AND VEHICLE DETECTION.....	37
7.4.1 General Observations: Train Detection.....	38
7.4.2 Vehicle Detection, Table 4.5 Only.....	38
7.4.3 Static Vehicle Detection.....	38
7.5 SYSTEM 5: TRAIN AND VEHICLE DETECTION.....	38
7.6 SYSTEM 6: VEHICLE DETECTION ONLY.....	39
8.0 SUMMARY AND CONCLUSIONS.....	40
8.1 TRAIN APPROACH DETECTION.....	43
8.2 ISLAND OCCUPANCY.....	43
8.3 STATIC HIGHWAY VEHICLE DETECTION.....	44
8.4 DYNAMIC HIGHWAY VEHICLE DETECTION.....	44
8.5 DROPPED AND OVERHANGING LOADS.....	44
9.0 RECOMMENDATIONS.....	44
9.1 ADDITIONAL INFORMATION: ITS.....	45
APPENDIX A: List of Crossing Component Advisory Team Members and Affiliations.....	A-1
APPENDIX B: Request for Technical Information.....	B-1
APPENDIX C: Test Matrices for Rail Operations and Highway Vehicle Operations.....	C-1
APPENDIX D: Highway Vehicle Detection Test Matrix.....	D-1
APPENDIX E: Test Results Tables 1-6.....	E-1
APPENDIX F: ITS Summary Report and Results.....	F-1

List of Figures

Figure 1	TTC Site Map	5
Figure 2	Post 85 — Detail of HRI Test Site	6
Figure 3	System 1 Solar Panel, Antenna, and Control Boxes	7
Figure 4.	System 2 Wheel Sensor	12
Figure 5.	System 2 Vehicle/Obstacle Detection Sensor, Combined Low Power Laser and Video Imaging System.....	12
Figure 6.	Illustration of Axle Counter System at Island and Approach Limits.....	13
Figure 7.	Description of Axle-Counter System.....	15
Figure 8.	Overview of Railroad Crossing with Axle Counters at Island	16
Figure 9.	17
Figure 10.	Ivent OMDS, Sensors and Regions of Sight.....	17
Figure 11.	Pictures of System Cameras in left picture, Scanner in right picture ...	19
Figure 12.	System 4 Train Detection Sensor	20
Figure 13.	System 4 Vehicle/Obstacle Detection Sensor	21
Figure 14.	System 4 Sensor Layout	21
Figure 15.	System 6 Vehicle/Obstacle Detection Sensors	24
Figure 16.	Top View of Detector Assembly of 4 pcs DT 272	24
Figure 17.	Schematic span Wire Installation for the Mounting of 12 Detector Assemblies	25
Figure 18.	Top View of Coverage Pattern with 12 Detector Assemblies	26
Figure 19.	Perspective Drawing of the Installation at the Test Site.....	27
Figure 20.	Post 85 Detection Zone Limits.....	31

List of Tables

Table 1.	Summary of System and Train/Highway Vehicle Detection Capabilities	32
Table 2.	Date and Weather Conditions.....	34
Table 3.	Summary of Train Detection Performance.....	42
Table 4.	Summary of Vehicle/Obstruction Detection	43

1.0 INTRODUCTION

Under sponsorship from the Federal Railroad Administration (FRA), Transportation Technology Center, Inc. (TTCI) evaluated five technologies for their ability to detect trains and/or highway vehicles approaching and occupying highway rail intersections. TTCI evaluated the technologies in November 1999 at the FRA's Transportation Technology Center in Pueblo, Colorado, USA.

2.0 BACKGROUND

Various train and highway vehicle detection technologies have been proposed as a means of operating and controlling alternative crossing warning and barrier systems. Currently in North America, the primary train detection method for activating grade crossing warning systems is accomplished by railroad track circuit based technologies that require the use of railroad rails for signal transmission. New technologies have been proposed that can be mounted off of the railroad property and/or do not rely on the rails for transmission of detection signals.

Previous work funded by the Federal Railroad Administration (FRA) and Association of American Railroads (AAR) highway/railroad intersection (HRI) safety programs was directed to investigating incidents and causes leading to loss of shunt at grade crossings and potential mitigation techniques (Task Order 106 report). Loss of shunt is the temporary or sporadic loss of track circuit shunting through the wheel/axle/wheel path and running rails. A number of mitigation techniques were evaluated including technologies that did not use track circuit shunting for train detection.

These technologies included the use of radar, magnetic anomaly, strain gage, infrared, and wheel counting technologies for train detection. These systems also offered the potential of providing additional information regarding train parameters (speed, direction, length of train) and other information that might feed future traffic control systems. In addition, since warning systems such as barriers and four quadrant gates are more sophisticated than conventional devices, the need to determine if the HRI road crossing area is occupied by a highway vehicle becomes increasingly important. Field testing of these technologies indicated significant problems with reliability; thus they have not been implemented. Results were reported in the final report for Task Order 106.

Technologies using off-track (or non track-circuit based) sensors may permit improved operation of HRI warning devices, however the development and availability of such

technologies is in its infancy in North America. Many technologies have been developed to address certain site-specific problems, or could be adapted from other industries. The goals and deliverables of this program included:

- Specifying operating/detection requirements
- Providing a test facility for evaluating performance
- Installing prototype technologies
- Conducting a series of evaluations simulating real world variations
- Reporting on the performance of a variety of technologies

Product development and performance evaluations outside of the stated requirements were not addressed.

3.0 TECHNICAL REQUEST FOR INFORMATION:

The scope of this effort greatly expanded the performance investigated by earlier work that addressed only loss of shunt using alternative train detection systems within the island limits. FRA and railroad users directed this. Technical direction was expanded to include representatives from FRA, John A. Volpe National Transportation Systems Center (Volpe Center), the Federal Highway Administration (FHWA), the American Association of State Highway and Transportation Officials (AASHTO), the Transportation Research Board (TRB) and railroads, who comprised the Crossing Component Advisory Team (C²AT). Appendix A lists C²AT members.

A Request for Technical Information (RFTI) was prepared (refer to Appendix B). It detailed minimum operating requirements for train and/or highway vehicle detection. Primary performance requirements stated in the RFTI included:

- Minimum train approach warning time of 20 seconds
- Release of island detection within 2 seconds after train departure
- Train speeds of greater than 5 mph to 125 mph
- Highway vehicle detection no greater than 9 feet and at least 7.5 feet from the rail at the road approaches to the crossing intersection
- Vehicle speeds of 0 mph, crawling, and up to 30 mph

The RFTI indicated technologies would be considered that could:

- Detect trains only (alternatives to track circuits)
- Detect highway vehicles only
- Detect both highway vehicles and trains

The RFTI did not request or require constant warning time. Most conventional modern track circuit-based detection systems can be designed to provide a constant warning (approach) time over a wide range of train speeds. Constant warning provides a consistent actuation time of the warning system prior to the train arriving at the HRI (generally set for 20 to 35 seconds depending on site specifics) regardless of train approach speed. Thus, a train approaching a HRI at 70 mph or 15 mph will provide the same warning time before arriving at the HRI. Representatives of many of the alternative technologies evaluated indicated that with the use of additional sensors and associated wiring/connections constant or more uniform warning could be achieved, however such options were not evaluated during these trials.

The vendor was to provide a prototype of the system and install it at TTC. The TTC site for testing did not utilize actual gates/flashers, but rather the evaluation consisted of monitoring the technology's output control signal (i.e., train approach, island occupancy, and/or highway vehicle presence) condition. All evaluations were conducted by comparing the technology's interpretation against an independent baseline measurement system, as stated in the Test Protocol section of this report.

During February and March 1999, the RFTI was sent to over 280 interested parties who had either participated in earlier loss of shunt testing, were involved with other HRI projects, or had shown interest in previous programs. In addition, members of the C²AT provided a number of contacts and vendors who were supplied a copy of the RFTI. By March 1999, the team received approximately 20 responses that offered to provide and install a detection technology.

3.1 SELECTION PROCESS

The C²AT ranked each submittal for technical merit. This included a review to determine if it addressed all performance requirements stated in the RFTI, the vendor's ability to provide a

prototype by the stated date, background of the vendor and associated personnel, and the vendor's ability to install the system at TTC for evaluation.

Of the 20 proposals submitted in response to the RFTI, 8 were selected for detailed review by the C²AT — of which 6 agreed to provide and install a system for evaluation by September 1999. Agreements were made with all vendors to provide limited flagging and safety support during installation. The FRA/FHWA Joint Program Office (JPO) provided additional funds to install five wooden poles and to provide trenching for cables used by several systems. All other expenses that were related to providing and installing the prototype systems were borne by each vendor. This included the costs of an additional pole needed by one system and special equipment rental. A limited number of checkout runs were conducted after installation. Each train detection system was intended to accommodate train operations over the double track line. Checkout runs included multiple passes of a train and vehicles over the HRI to verify system operation and (when needed) to allow sensors to be calibrated.

Vendors were provided a 2-month window to install and check out their systems after which no further adjustments were allowed. Due to product availability and development issues, only five of the six selected vendors installed their systems in time for the track and crossing test sequences, which started October 26, 1999 and were completed by November 19, 1999.

3.2 TEST CROSSING DESCRIPTION

There are over 50 miles of track at TTC configured for a variety of testing conditions, including high-speed loops, heavy freight tracks, and yards and logistics connections. Figure 1 shows a map of the TTC tracks and highlights Post 85, the double track HRI crossing selected for these tests. The Transit Test Track (TTT) consists of a 9-mile loop and is also configured with a third rail for direct current power. The Railroad Test Track (RTT) is a 13.5-mile loop with an overhead catenary for use in evaluating electric locomotives. The overhead power supply can be altered to provide a wide range of voltages for specific test purposes. Testing for this program concentrated on the TTT, while the RTT was used for higher speed trains and when more than one train was to be operated. Figure 2 shows a detail of the Post 85 HRI road crossing and tracks.

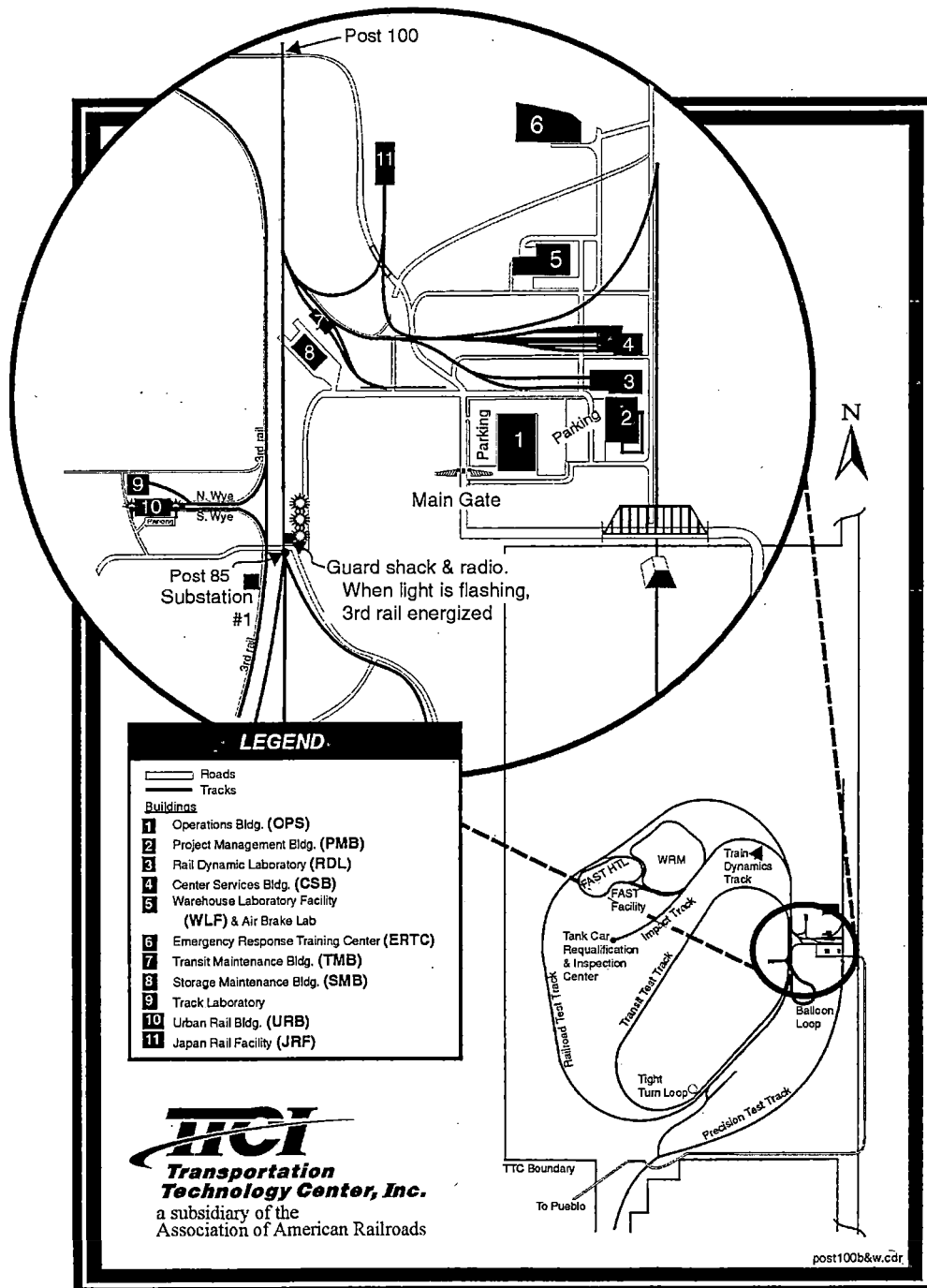

Figure 1. TTC Site Map

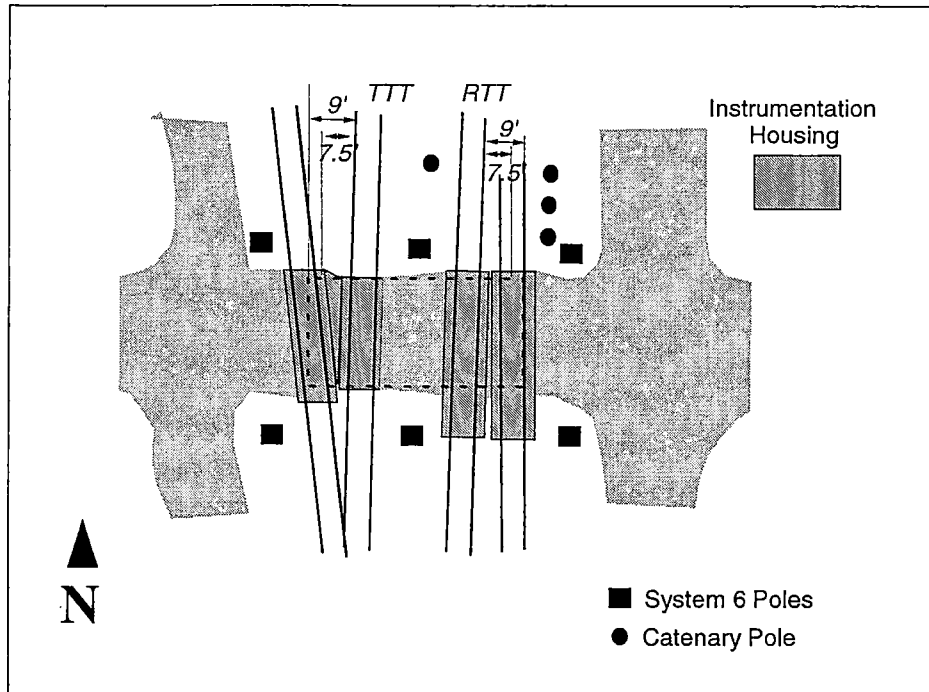

Figure 2. Post 85 - Detail of HRI Test Site

This location includes parallel mainline tracks with some nearby switches leading to yards and turning facilities. During these evaluations trains occupying and/or moving on nearby tracks and connecting switches were ignored. The maximum allowable speed on the outer RTT loop is 160 mph, while the inner TTT loop is 80 mph. The TTT power rail was de-energized during testing. The RTT overhead catenary system was de-energized, with the exception of high speed runs in excess of 100 mph. High speed runs used an electric locomotive or trainset that required the 25KV/60 Hz power to be applied to the overhead catenary.

The existing road crossing was paved with asphalt using both rubber insert and wood timber crossing surfaces. Approach roads were either paved, gravel, or dirt. A large wooden bungalow was installed about 35 feet to the east of the RTT to house all equipment needed by the detection systems, the TTC data collection equipment, and to act as a central location for test personnel during evaluations.

Most testing that required train moves was conducted on the TTT. Subject to planned track maintenance requirements, the RTT overhead power was generally off. When conducting tests for this program no trains were operated on the RTT to allow specific moves on the TTT to be made without other train interference. The only exception to this was when specific parts of the

test matrix called for concurrent train moves. In these instances, adjacent tracks (both the RTT and TTT) were used for controlled train movements.

4.0 SYSTEM DESCRIPTIONS

The five technologies installed for evaluation are described in this section. For this report, these systems will be referred to as Systems 1, 2, 3, 4, and 6. System 5 was not evaluated at the time this report was prepared.

4.1 SYSTEM 1

System 1 was evaluated as a train presence detection system only. This system uses a combination of magnetic anomaly and vibration detectors in a sensor module. These sensors detect a magnetic field change caused by an approaching train. The vibration detectors in the module detect vibrations caused by nearby moving trains. These sensors operate independently of each other. A total of 12 sensors were required for the TTC installation, 6 on each track. The number of sensors needed for island detection is a fraction of the total island length and the shortest railcar that is to be detected. Based on previous tests, the vendor selected a 40-foot spacing, and for seven of the TTC tests, four sensors were used over the 120-foot island. Two sensors are placed at each end of the approach limits to detect approach trains and two additional sensors are used at the island with one on each side of the HRI. Information is transmitted from each sensor to the control module located near the HRI via RF transmission, as shown in Figure 3.

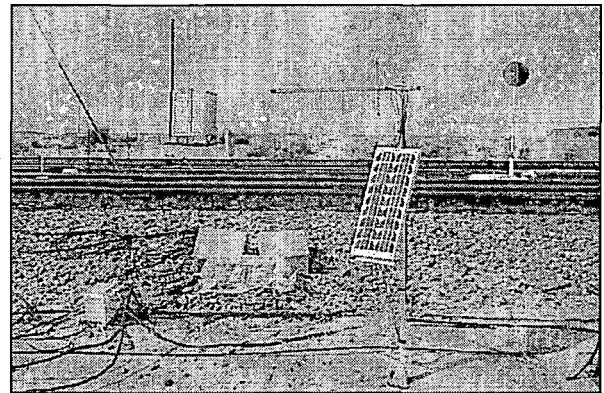

Figure 3. System 1 Solar Panel, Antenna, and Control Boxes

The outlying “approach” sensors can be placed at such a distance that the train can come to a complete stop before reaching the HRI crossing, or the warning system is activated a sufficiently predetermined time (in the case of TTC testing this was 20 seconds) at train speeds of up to 200 mph. A detailed system description, as provided by the vendor, is discussed in the next section.

4.1.1 Detailed System Description

- A baseline monitoring system for a single track consists of a master system located at the island and two slave stations remotely located one on either side of the master. The distance between a slave and the master is chosen so that with the fastest train the programmable warning time can be accomplished. Master and slaves are in constant communication via wireless data link. Communication by buried cable over the required distances would cost more than the baseline system itself and pole mounted telephone wiring are not suitably reliable.
- A slave station consists of a set of magnetic anomaly sensors, which can be buried under the roadbed.
- A controller analyses the data from the sensors and sends a message packet to the master if and when required via a VHF data link employing a directional yagi antenna. The system is so designed that optional repeater stations can be installed in between slave and master if required.
- The slave stations detect the passing of a train, its speed and direction and on which track
- The master station is located at the level crossing. In a revenue service environment, with an integrated train and vehicle detection system it would consist of a number of sensors buried in the roadbed spaced at intervals so that no car or locomotive can be on the island without detection. In this way, no switching moves or reversal of direction can confuse the detection system. This vehicle/obstacle detection option was not evaluated during the TTC trials.
- A controller that combines the sensor signals and via a decision matrix determines the status of the island.
- A wireless transceiver is in constant communication with the slave stations. This data link checks the status of the slave systems and receives detection information from the slaves.
- During a previous series of tests conducted at TTC a shortcoming of the detection system was discovered. When a strong manmade permanent magnetic field was present, one or more sensors could become saturated and the magnetic anomaly detector would then no longer detect the field change caused by an oncoming train. A seismic solid state sensor was added to each sensor. Additional logic permits detection of the arrival of a train either at a slave or the master site. This is an exception handling operation. Measurements taken during system tests conducted by TTCI have demonstrated the strong correlation between magnetic

anomaly signals and the seismic signals. However the exception handling function was not specifically tested under all operating conditions.

- Each controller has a user interface port. The port can be connected to a PC. In this way a quick status report can be obtained of the system, in particular the threshold settings.
- Field adjustments can be made without having to open up the system. In this respect it should be mentioned that this feature would allow the addition of a solid-state event recorder, which can for example store the operational events of the last 24 hours.

4.1.1.1 Controller

The controller is a standard design. Its functional performance is controlled by software. It polls the data it receives from the sensors, performs an analysis, and performs the programmed action.

The controller can operate four sensors simultaneously. The slave systems are in communication with the master station via a wireless transceiver forming a continuous digital data link.

The baseline system consisted of three units: two slave units and a master unit located at the island. The slave units are spaced on either side of the master at such a distance that if the master has issued a stop order to the slave the oncoming train can be safely brought to a halt before reaching the island. The slave(s) send measured train speed to the master which will actuate the gate closing system a programmable amount of time ahead of the expected train arrival time at the island.

The master monitors the built-in test systems of all three subsystems. In case of a detected failure, the system shuts down and closes the gates (Failsafe). Further, the controller has eight input/output (I/O) lines that are computer controlled and can be used for auxiliary monitoring or control functions.

The controller has a PC interface and is field programmable. Simultaneously, with an optional data acquisition unit it can serve as a “blackbox” to provide a permanent record of events — a feature that was extensively used during the TTCI tests. The controller meets all environmental requirements of a class A equipment but is not submersible. This requirement can be met as an option. If communication situations require it the controller can be configured as a relay station.

4.1.1.2 Sensor Design

The sensor subsystem consists of a dual magnetic anomaly detector. Two sense coils are mounted at right angles to each other in the vertical plane. They operate individually in the second harmonic mode.

When properly placed, the plane of maximum response lies parallel with the track while the sensitivity across the tracks is minimized. This has been verified by tests at TTC. The test consists of two parallel tracks being instrumented and a construct passing over one of them (refer to Figure 2 for results).

To compensate for the fact that the local magnetic field can be different from locale to locale, a special Automatic Zero Set (AZS) system was developed to eliminate the effect of local ambient fields. This process is controlled and repeated when the ambient field change requires correction. The detector system is now normalized permitting the setting of a threshold to make the decision train-no train and to eliminate the probability of a false alarm (PFA).

At a slave station they are always two sensors per track placed a known distance apart. This is done for two reasons: the time interval measured between a construct passive sequential over these sensors indicates train speed, and this configuration reduces the probability of a false alarm to nearly zero. Even in the case that severe magnetic storms or nearby lightning would trigger the sensors this would be a simultaneous event and would be discarded by the system as “not a train.”

The sensor can be summarized as follows:

- The sensor is housed in a solid aluminum box, submersible as tested to 2 meters of water.
- It meets the requirements of the AAR Part 11.5.1 environmental parameter limits Class A (roadbed)
- It can be buried under the roadbed more than 1 meter
- Cabling is a proprietary design exceeding relative military specifications for electrical performance and environmental exposure
- Mean time between failure (MTBF) according to military specification HDBK 217 is in excess of 50,000 hours.
- Built-in test is automatic
- Probability of detection is 99.9999 percent
- Probability of a false alarm is $< 10^{-9}$

4.1.1.3 Power Supply

The system is battery powered. The batteries required should have a minimum capacity of 200AH each; thereby providing a minimum of 60 days continuous operation without re-charge. Normally, one battery is used per system per track at any one time with automatic switch over to the other battery if the first one becomes discharged.

A solar panel of industrial quality is provided that will automatically recharge which of the two batteries is in the standby mode. To what extent operational time is extended beyond 60 days depends on the average hours of sunlight available. The type of battery installed depends on the climatological conditions at the place of installation and has to be decided in consultation with the user. Depending on the type of battery the recharge profile may have to be adjusted. By automatically cycling from one battery to the other battery life is considerably extended.

4.1.1.4 Antenna

The antenna is a 5-element yagi with a 10dB gain. This increases the effective transmit power by a factor of 10. In the receive mode the ambient noise level is reduced by 10dB so the antenna provide a net channel gain of 20dB

4.1.1.5 Communication

The communication system consists of a 5-watt VHF transceiver coupled to a directional yagi antenna. The transceiver has a built-in modem to interface with and be controlled by master or slave controller. The master station tests itself and via the communication link also the outlying slave stations. One or more of the I/O ports of the controller can communicate alarm conditions.

The transceivers are normally in the receive mode so that any subsystem can initialize a message at anytime. With the programmable control system it is envisioned that these local island protective circuits will develop into regional and national monitoring systems. A data link with oncoming trains will become a critical feature.

4.2 SYSTEM 2

System 2 was evaluated as an integrated train and vehicle detection system. This system used double wheel sensors for train detection. Each sensor housing consisted of a pair of resonant circuits designed to detect the approach and departure of trains. System 2 uses two sensors, one on each rail, at each approach limit to count the axles passing over the sensor and indicate train approach. A sensor on each side of the HRI acts as the island circuit. When the number of axles

counted in at the approach matches the number of axles passing over the island in the same direction, the system indicates a clear circuit. Each sensor pair is hardwired to the control circuit located near the HRI. For vehicle detection this system utilized a combination of low power laser and video imaging to detect obstacles at the HRI.

A detailed system description, as provided by the vendor, is included in the next section.

4.2.1 Detailed System Description

The Level Crossing System for the TTCI tests consisted of six double wheel sensors (Figure 4) and a double height 19-inch rack with computer card, sensor interface cards, counter card, RS-232 interface card, internal power supply, and other necessary interface cards. A low power laser and video imagery system was used to detect highway vehicles (Figure 5). The rack also included potential free outputs to control the crossing gates and lights and provide failsafe functionality. For the basic function, the train has to pass first the approach sensor, then the island sensors, and at least the approach sensors at the other side. Only then, will the control system recognize a complete train movement and set all parameters from the program back to the start ready state.

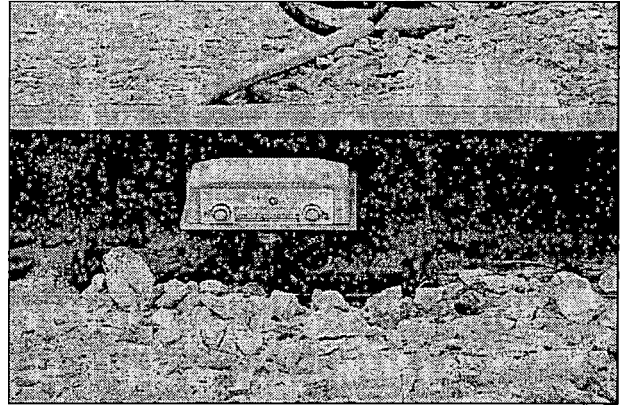

Figure 4. System 2 Wheel Sensor

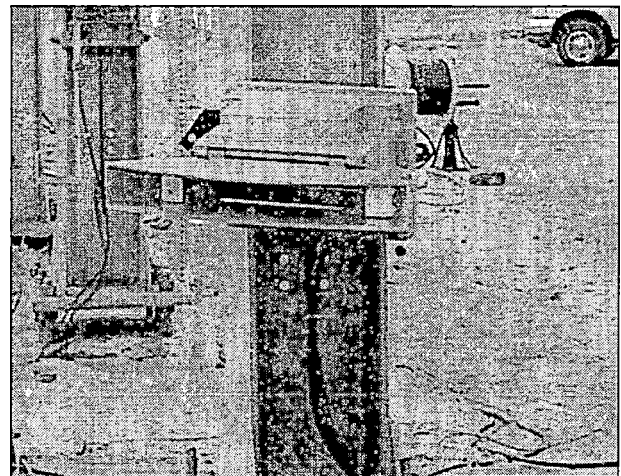

Figure 5. System 2 Vehicle/Obstacle Detection Sensor, Combined Low Power Laser and Video Imaging System

For the TTC layout each track (RTT and TTT) employs two double wheel sensors at each approach for triggering the system from trains approaching in either direction toward the crossing. The first sensor that crosses at the approach starts the system activation; the second sensor at the approach is placed as a redundant sensor in case of a problem with the first sensor. Two double wheel sensors are used as the island axle counter circuits at the crossing, and serve as the primary control signal to switch the gates and lights off after the train leaves the crossing.

The first double wheel sensor is installed about 20 feet before the crossing as part of the island axle counter circuit. The second double wheel sensor is installed about 20 feet after the crossing to complete the island axle counter circuit (Figure 6.)

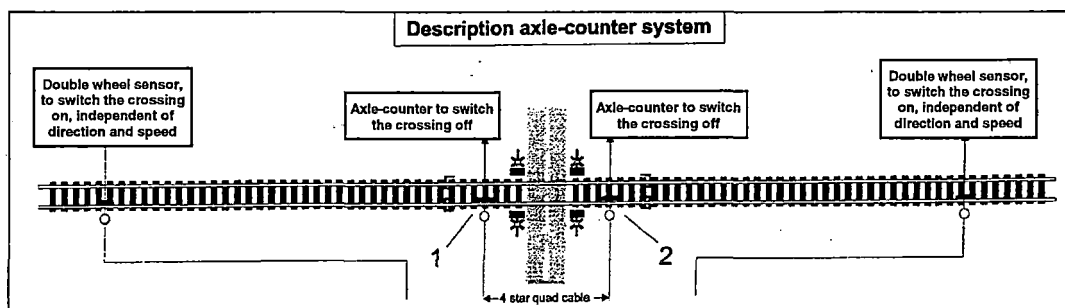

Figure 6. Illustration of Axle Counter System at Island and Approach Limits

Once an approach sensor has been crossed, the system begins storing axle counts and the crossing system is activated (e.g., lights and gates) as the train continues to the crossing. The crossing is flagged as being occupied when the train passes the first island sensor of the island axle counter circuit going to the grade crossing. The system then begins counting the number of axles that pass this sensor and all lights and gates remain active while the train is present at the crossing. As the train continues through the crossing and crosses the second sensor in the axle counter circuit, the system begins counting the number of axles that pass over this sensor. The control system keeps track of all axles counted at each wheel sensor. Once the last car in the train passes the second double wheel sensor used in the island axle counter circuit, the system compares the number of axles counted at the approach sensor with the two that make up the island axle counter circuit. If, after comparison, all three sensors have counted the same number of axles, the crossing is considered to be cleared and the crossing lights and gates are immediately switched off. If a failure occurs at one of the island wheel sensors, the backup to switch the crossing system off will be the wheel sensor at the opposite approach. This ensures that the system is switched off and set back to the start ready state. The only difference being the time it takes before the system switches the crossing system off, which is the time it took the last car in the train to pass over the approach wheel sensor in the opposite direction. Note that all sensor control cables are monitored for broken wire or a short circuit, in which case the system can be set via software programming to the occupied state and the crossing can be switched on. Rather than switching on the crossing, the system can display a message via the RS-232 supplied

output indicating that a problem has occurred. Or a warning light can be displayed to the locomotive driver.

This system function was the same for both the RTT and TTT tracks; the only changes in the system layout occurred in the location of the approach wheel sensors on the track. The approach sensors must be placed at a distance based on the maximum speed any train using that particular track will attain, so as to provide a safe stopping distance and allow for the proper 20-second warning time. In the case of the RTT track the approach sensors were set much further out due to the faster speeds attained on this track.

Each double wheel sensor records wheels without contact, independent of velocity or direction. The module receives impulses from the double wheel sensor and forms them to a digital output. Pulses from the double wheel sensors provide a signal to switch the crossing on, and record direction and speed information (Figure 7).

For switching on the crossing system the control system needs only the information from one of these double wheel sensors. Each sensor that is counted is stored. This makes it possible to compare the result of each individual sensor, and to thereby determine if there is a single train or if a following train is approaching. It will also detect if the train left the area by changing the direction before reaching the level crossing. If this has occurred, the system will switch off the crossing system. The information from the double wheel sensors will be transmitted to the computer system and the control system will be switched on directly or with a programmable delay time after checking the direction and speed.

The pulses from each axle-counter are counted and verified. If the sum of pulses of axle-counter 1 equals the sum of axle-counter 2, the island is immediately switched off. To increase the availability, it is possible to switch off the system, if three sensors have the same result of counted axles.

The interface AML realizes the connection from the computer system to the existing crossing system. The cable to the axle-counter is tested continuously for a broken wire or a short circuit, if there is no train on the island. Each double wheel sensor is tested continuously for correct fixing to the rail, if the sensor comes loose a signal will be provided as an output for notification and

the system can be set to fail safe via software programming if so desired. Figure 8 provides an overview of a complete level crossing system.

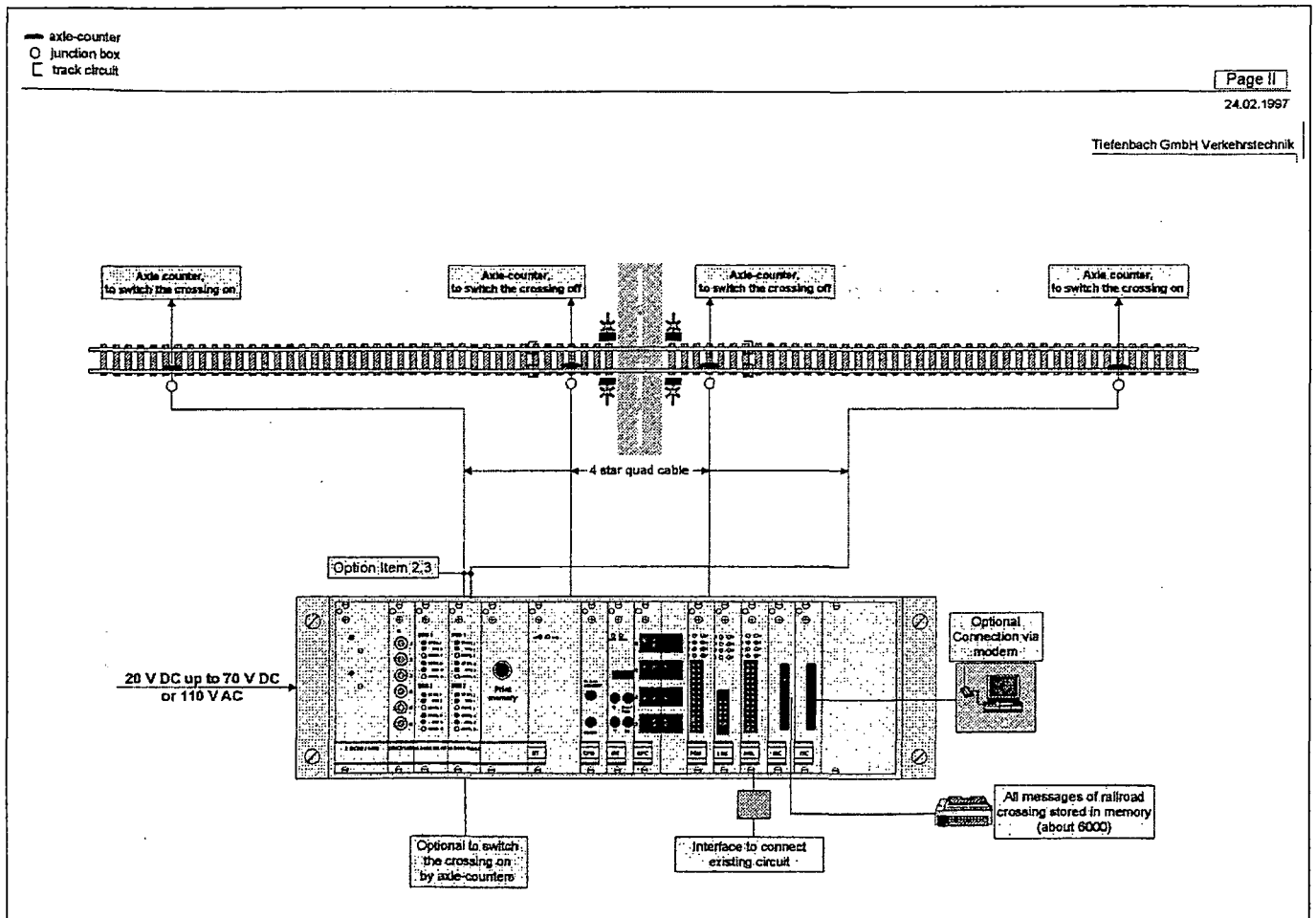
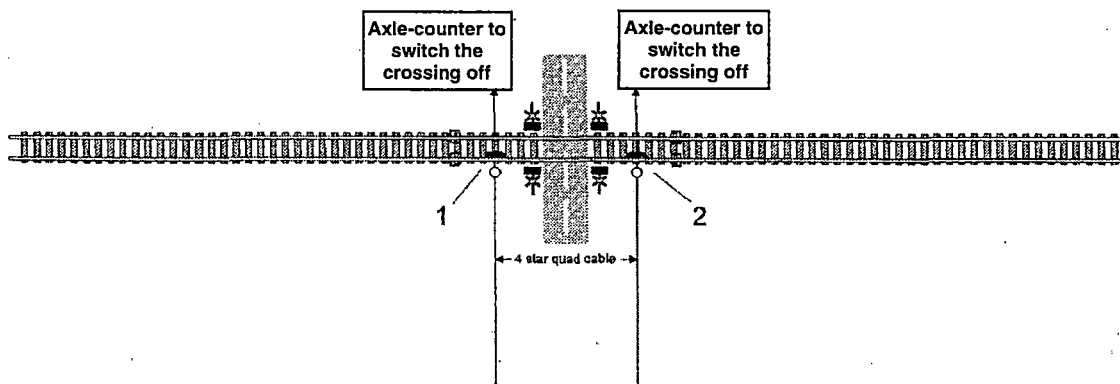

Figure 7. Description of Axle-Counter System



Description:
 Each axle-counter records wheels without contact independent of velocity and direction. The module 4AB10/1.105/13 receives impulses from the axle-counter and forms them to a digital output, which will be received from the module FEM. The pulses from each axle-counter are counted and verified. If the sum of pulses of axle-counter 1 equals the sum of axle-counter 2, the island is immediately switched off. The interface AML realizes the connection from the computer to the existing crossing system.
 The cable to the axle-counter is tested continuously on broken wire or short circuit, although if there is no train on the island.

Figure 8 Overview of Railroad Crossing with Axle Counters at Island

4.2.2. Description of System 2 Vehicle Detection: Theory of Operation

The IVent Opto-electronical Monitoring and Detection System (OMDS) is based on the fusion of the advantages of an automatic, photogrammetrical plotting of a stereo image pair and the spatial data acquisition by means of laser scanner range measurements and necessary specially designed detection software.

The opto-electronic devices enable the system to detect the presence of any obstacles such as pedestrians, animals, dropped cargo, vehicles, vehicle overhang, or overhanging loads in the area of interest.

4.2.2.1 Components

The IVent OMDS consists of two principle units :

- 3D-CCD IR double camera system - the camera system holds two oriented fixed CCD-cameras with a high spectral sensitivity from visible light to the near infrared
- 3D Laser Scanner - The 3D Laser Scanner is a high speed rotating scanner with frame scan ability operating in the near infrared.

4.2.2.2 3D Laser Scanner

As shown in Figures 9 and 10, the laser scanner uses the principle of coordinate acquisition by directional range measurements from a known point.

The sensor can be characterized as follows:

- Time-of-flight method
- Near-infrared wavelength
- Pulsed diode laser transmitter
- Sensitive narrow-band optical receiver
- Single pulse or multiple pulse signal detection
- Microprocessor-based post-processing and interfacing

To acquire the shape of the entire scene, the 3D Laser Scanner measures the distance to every point within the crossing limits. The software reconstructs the surface information of objects within the observed area.

4.2.2.3 3D-CCD IR Double Camera System

The 3D-CCD IR double camera system consists of the following elements:

- Two fast, medium resolution CCD cameras with a spectral sensitivity from the visible light up to near infrared
- Trigger (assures the synchronous picture capture)
- High speed frame grabber

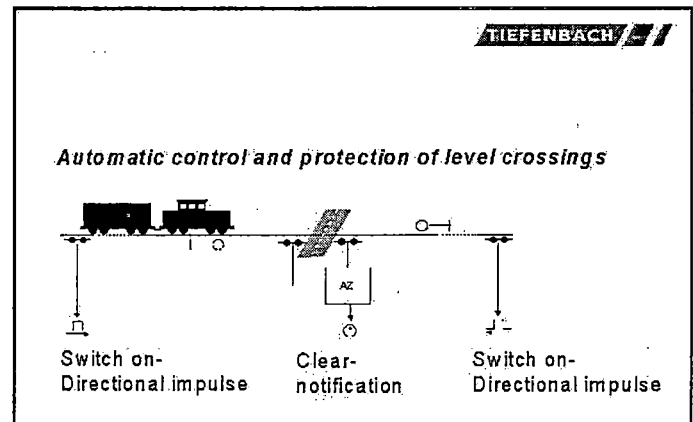

Figure 9. caption

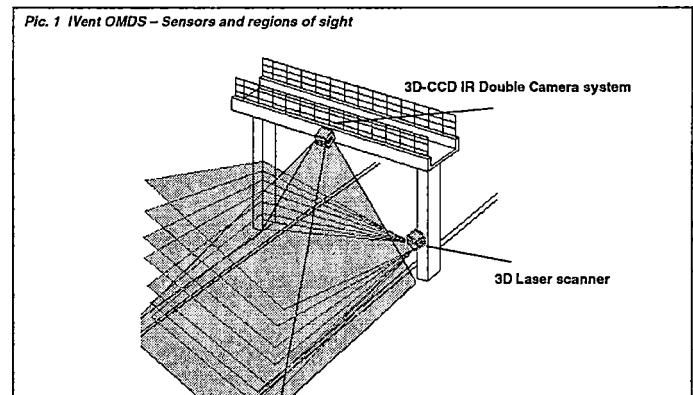

Figure 10. IVent OMDS, Sensors and Regions of Sight

- Additional ambient light-sensitive infrared lighting device
- Interface to central controller unit (CCU)

The system simultaneously acquires the two camera images, removes lens distortions, and calculates the intrinsic and relative orientation parameters. It then correlates the pictures. The correlation between the images allows the generation of dense depth maps. This depth information can be used to calculate three dimensional point clouds, from which the entire surface information of the observed object can be derived.

4.2.2.4 Combination

Basically the two systems, 3D-Laser Scanner and 3D CCD-IR-Double Camera System, independently serve to acquire the same kind of information. But this has a few good reasons working under the special requirements of security-sensitive circumstances. The redundancy of the measurement devices is intended and the advantages are systems work together to provide a higher degree of accuracy detecting images or objects in detection zone. However the systems can work independently of each other.

4.2.2.5 Software: Object detection

The principle software components include:

- IVEnt 3D-Calculator LS
- IVEnt 3D-Calculator CAM
- IVEnt 3D-Change-Detector

The modules IVEnt 3D-Calculator LS and the IVEnt 3D-Calculator CAM calculate the spatial information inside the operating area of the respective system and make them disposable to the IVEnt 3D-Change-Detector. In the IVEnt 3D-Change-Detector the data is cleaned and errors are detected.

4.2.2.6 Summary

The main advantages of the system are summarized:

- Redundant measurement information in the main area of interest
- Coverage of marginal areas through at least one sensor
- Sensors can also operate independently

- Picture-information from camera-systems can be transmitted to the approaching train or other users
- No disturbance of the railroad services by using the natural or infrared lighting
- High resolution
- Low sensitivity to weather impact through installation in conditioned boxes
- Low susceptibility to damage through contact less measurement

Using the surface information from other systems such as Radar or Ultrasonic can generate an interface to other applications. The integration of the system into the environment of the System 2 - Level Crossing Safety System is shown in Figure 11a and 11b.

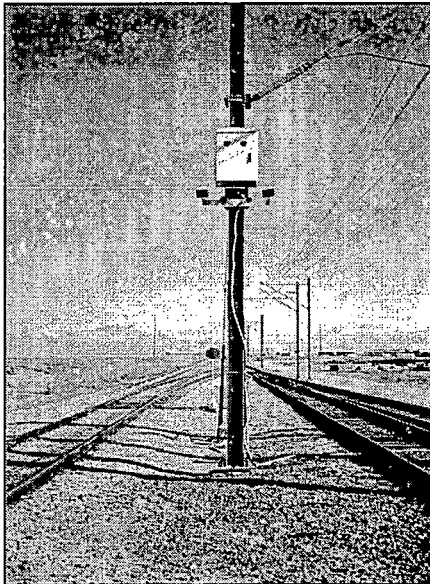

a. Cameras

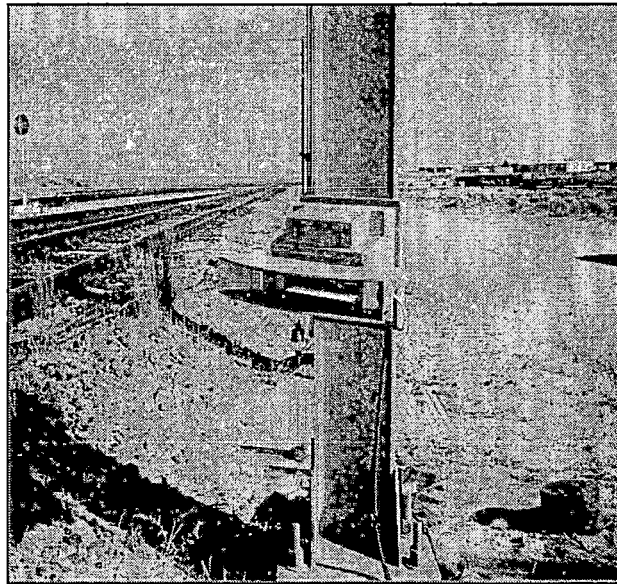

b. Scanner

Figure11. Pictures of System Cameras in left picture, Scanner in right picture

4.3 SYSTEM 3

System 3 was evaluated as a train detection system only. This system used a low power module with vibration and magnetic anomaly sensors to detect the approach and departure of a moving train. A module was placed on each of the approach limits of the TTT to detect an approaching train. Another module was placed near the HRI to act as an island circuit. These modules were linked to the control module at the HRI via low power RF transmissions. Sensors were not installed on the RTT at the discretion of the vendor. No pictures or additional descriptions were available for System 3.

4.4 SYSTEM 4

System 4 was evaluated as integrated train and vehicle detection system. As shown in Figure 12, this system utilizes inductive loops placed between the running rails to detect the approach of a train. Two of these inductive loops were placed at each approach limit on the RTT and TTT to detect the approach of a train. A single loop was placed on each side of the HRI on the RTT and TTT to act as island circuits. These loops were hardwired to the control unit at the HRI. To detect vehicles within the HRI, System 4 utilizes a single radar unit placed on one side of the HRI (Figure 13). A schematic layout is shown in Figure 14.

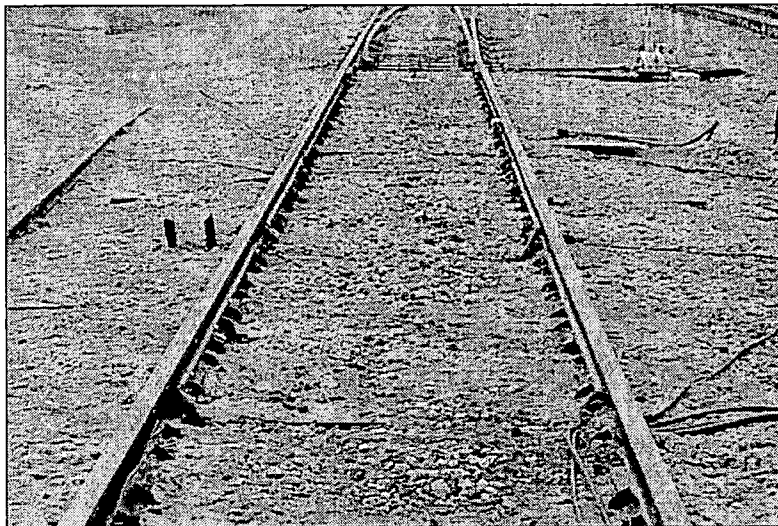

Figure 12. System 4 Train Detection Sensor

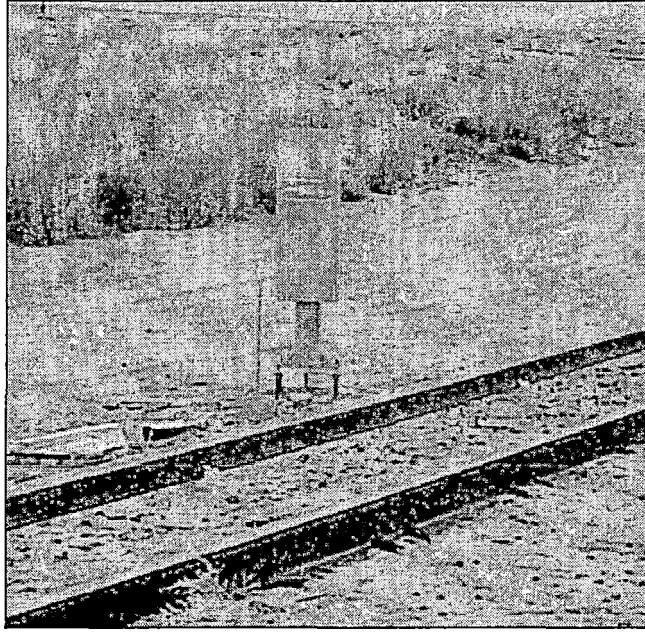

Figure 13. System 4 Vehicle /Obstacle Detection Sensor

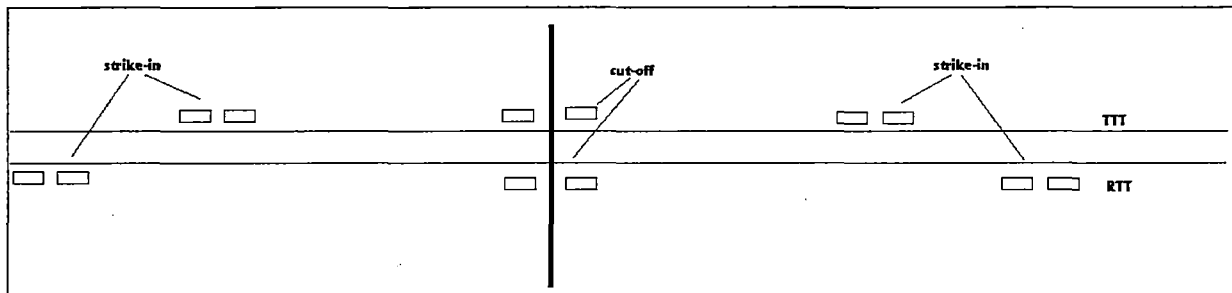

Figure 14. System 4 Sensor Layout

Additionally a separate system was installed to act as an independent island circuit. A single loop was placed on each side of the HRI on the RTT. These loops were hardwired to a special control unit at the HRI. This Strike-out Interface (SOI) was applied as substitute for insulated joints (Figure 14). The SOI device has not been part of the integrated train and vehicle detection system mentioned earlier.

4.4.1 System Operation

System 4 is a serial product applied by German railroads (DB AG and others). The system was configured to support failsafe strikes according to the open loop principle. Other optional operation modes can be configured. The full electronic control unit can act as a 2-of-2 or 2-of-3 microprocessor system.

Trains are recognized when passing a strike-in circuit. A strike-in circuit is made up of two inductive loops at approach limit. The approach limit depends on minimum warning time and maximum train speed. The warning time is designed for the fastest train. The order in which trains pass the loops is used to calculate the direction of movement. Approaching trains activate the warning signal but the warning time depends on the speed of train. The warning itself lasts until a train has passed the corresponding cut-off circuit. A cut-off circuit is made up by one inductive loop placed at each side of the HRI. Warning is deactivated when the train has passed both loops. The deactivation of warning occurs 1.5 seconds after clearing the second loop. The system assumes a vehicle or train is approaching the over strike-in circuit and passing the cut-off circuit. For other operational situations the system needs additional control information via hand switches or signal input. Separation of trains is not assumed in system concept and will not be detected.

The SOI device is a serial product applied by DB AG and others. The device supplies criteria for the occupation of the HRI. One inductive loop is positioned at each side of the HRI to complete the SOI. An occupation of one of the loops is evaluated as occupation of the island. When both loops have been occupied and freed again island detection is released. The release is indicated immediately.

4.4.2 Train Detection

For train detection, this system uses inductive loops placed between the running rails to detect vehicles and trains. The cable in the track is installed in a figure eight shape. The loop belongs to an oscillator circuit with a resonance frequency of about 26 kHz. The oscillator is damped by electric conductive materials situated in the electromagnetic field of the loop. The double sensor detector (DSD) subassembly contains two independent oscillator circuits.

The detection of an occupation by train vehicles is independent of axle-short-circuits and of the ballast resistance of the track. Driving currents, audio frequency track circuits, and European

systems do not influence the proper function of the DSD. A manual loop compensation while putting in operation is not necessary as the DSD adjusts itself automatically.

The loops can be operated in two different configurations: with test pulses or without. The detector generates test pulses to proof the correct operation of the loops and the transmission of the output signals even without a vehicle passing by. System 4 uses loops with test pulses. The SOI device uses loops without test pulses because there is no need for it at cut-off circuits. Note that the basic relay realization is not capable of evaluating frequently changing detector signals.

4.4.3 Test Arrangement

The distance between strike-in circuits and the HRI depends on the maximum train speed allowed on the track. For a maximum train speed of 90 mph on the TTT, the approach limit calculates to 2,700 feet. For a maximum train speed of 125 mph on the RTT, the approach limit calculates to 3,700 feet. The strike-in circuits were built up by two inductive loops and one detector circuitry in a connection box. The connection to the signal housing at the HRI was made via a four conductor cable for each strike-in circuit.

Because of its proximity to other systems under evaluation, cut-off loops and the loops of the SOI system were not installed at optimal places. The loops should have been installed 6 feet off the road. Instead, the loops were located up to 300 feet off the HRI. The circuits were built up by two inductive loops, a detector circuitry in a connection box at the first loop, and an additional connection box at the second loop. For the interconnection between the boxes a double-shielded 4-conductor cable was used. The connection to the signal housing at the HRI was made via a 4-conductor cable for each circuit.

Because of system principles, separation of trains is not assumed. If an approach is detected and the detected vehicle is leaving without passing the HRI (e.g., train is turning back or using a turnout, or a Hi-rail vehicle is leaving on the road) this system will not automatically deactivate the warning signal. In Germany, hand-switch units are provided in such cases to give manual commands to the system.

4.5 SYSTEM 5

This system was not installed in time for testing and has not been evaluated as of the preparation date of this report.

4.6 SYSTEM 6

System 6 was evaluated as a vehicle/obstacle detection system only. This system uses a combination of passive infrared and ultrasonic detectors to indicate a vehicle/obstacle within the HRI. These sensors are suspended above the HRI aimed such that the detection components face downward onto the highway road surface. A total of 12 sensors were arranged above the TTT/RTT HRI to cover the area specified in the RFTI. A clearance from the 25KV catenary wire was required on the RTT; thus the sensors were installed approximately 5 feet higher than the optimum distance desired by the vendor.

4.6.1 Detector Assemblies

For the prototype installation, four standard detectors model DT 272 were mounted on a common base to form a detector assembly with one logic output having a sufficiently large detection pattern. A detector assembly results in a pattern of approximately 10 to 12 feet in a square (see Figures 15 and 16) depending on exact mounting height.

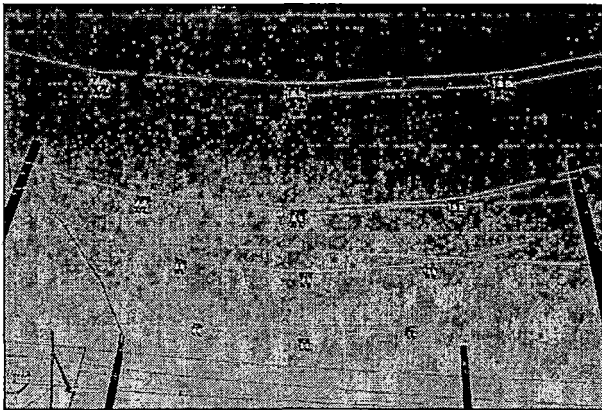

Figure 15. System 6 Vehicle/Obstacle Detection Sensors

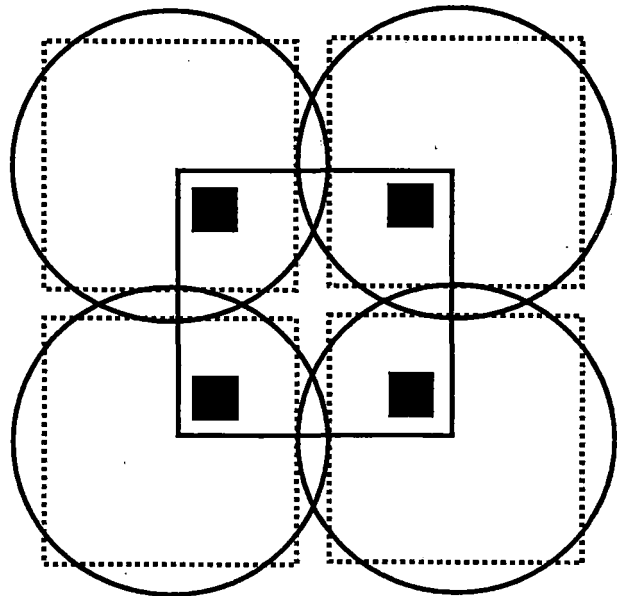

Figure 16. Top view of Detector Assembly of 4 pcs DT 272

4.6.2 Mounting of the Detectors

For the test a simple and cost effective solution had to be found and it was decided to use a span wire construction supported by six poles to mount the detectors. Double span wires were chosen in one direction for better stability of the detectors, as shown in Figure 17.

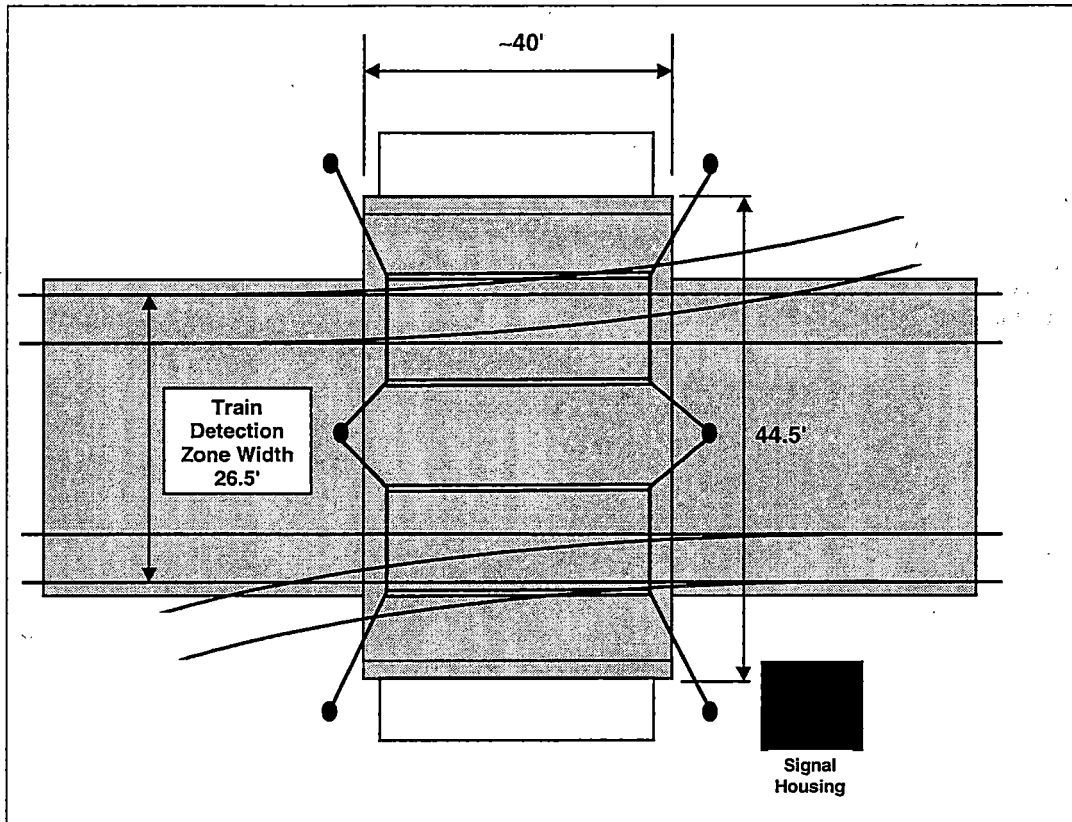

Figure 17. Schematic span Wire Installation for the Mounting of 12 Detector Assemblies

4.6.2.1 Detection Pattern on the HRI

Using this approach with an array of 4×3 assemblies a virtually uninterrupted detection pattern could be achieved as shown in Figure 18.

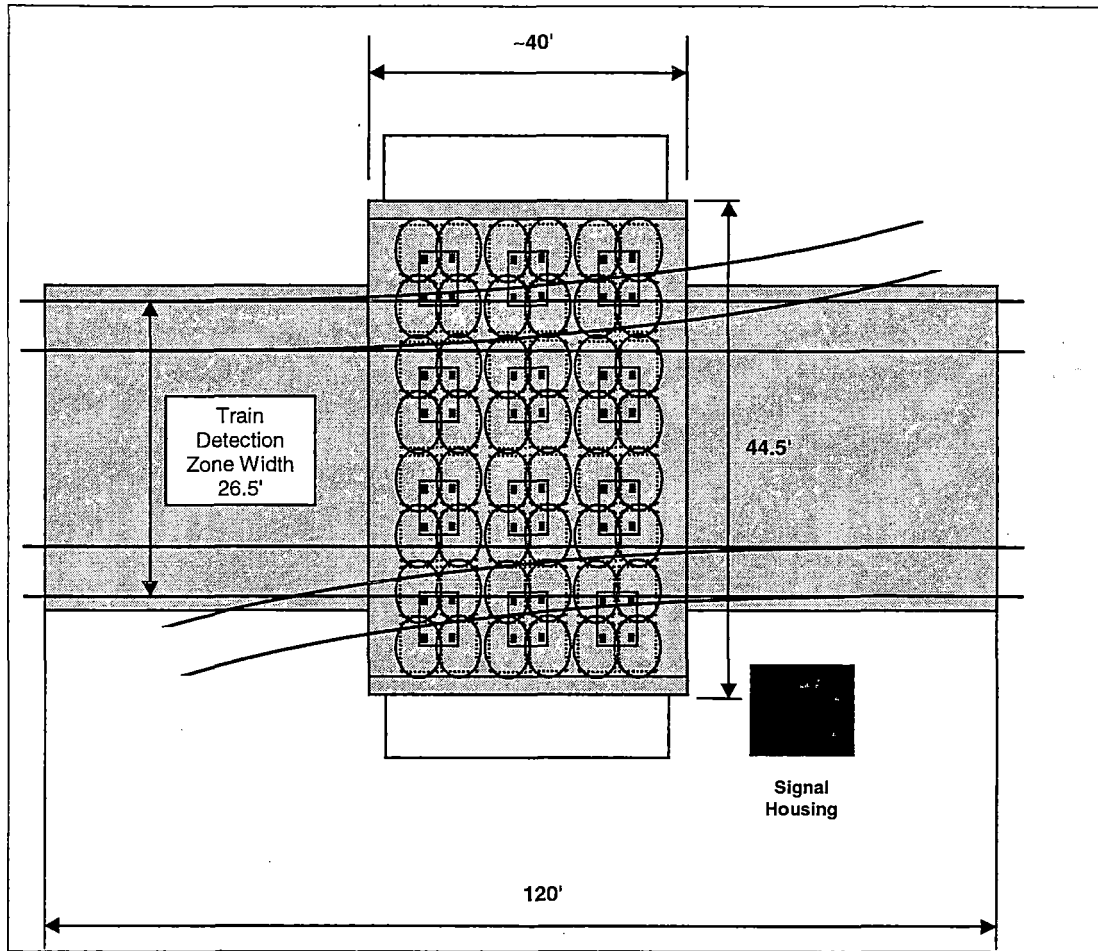

Figure 18. Top View of Coverage Pattern with 12 Detector Assemblies

Please note that Figures 17 and 18 are designed to give approximate dimensional information on the actual installation used for the tests and are not absolutely to scale.

4.6.3 3-D View of the HRI with Detectors Installed

Figure 19 is a perspective drawing of the HRI illustrating the installation as it was used for the test.

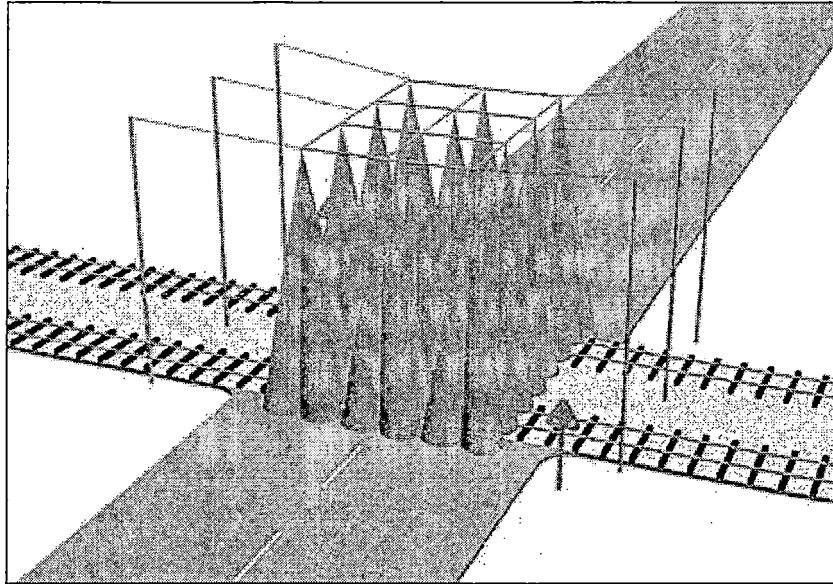

Figure 19. Perspective Drawing of the Installation at the Test Site

4.6.4 Configuration of the System

Per the request of TTCI the detector assemblies were configured to give one common output for all the 12 detector assemblies. With this configuration, the system gives detect information independent of the location of the target detected.

4.6.5 Potential Applications

Outputs

With relatively little effort it would be possible to monitor separately the 12 outputs from the individual detector assemblies. This approach would give additional information on the actual position of a target and it would allow a target to be followed as it moves through the HRI. This would afford the user the ability to determine actual position of the target at all times.

The RS 485 two-way communication is a part of the detector assemblies and is used for system configuration and diagnosis of the analog signals. The RS 485 makes it possible to combine the detection information in one protocol using a single 2-wire data bus to monitor the detect state of each detector.

Mounting

Although it is possible to mount detectors on span wires, it may be necessary to review and possibly revise the mounting structure if more extended tests were to be performed. For a long-term test on a real crossing, the detectors would be mounted on a structure modified for higher rigidity. This could mean that at the least the rectangle holding the detectors would be rigid with this part held in place by span wires.

5.0 PROGRAM AND TEST PROTOCOL

The following steps facilitated the selection of technologies and testing:

1. C²AT ranking and selection of technologies
2. C²AT meeting with vendor representatives and detailed questioning
3. Final selection of technologies
4. Vendor notification of selection, scheduling of installation
5. Vendor install and check out technology
6. Test train and controlled highway vehicle operations, collect performance data
7. Data review by C²AT
8. Final report

Each vendor was provided a 2-week window for installation and initial checkout of their system. After completion of installation, a test train was operated over the crossing to allow the vendor to ensure all operating parameters were to their proprietary standards. Data collection was conducted by TTCI personnel and consisted of monitoring the output condition of each system for one or more of the following conditions:

- Train detection on the approach
- Train on the island (time that the train occupied a 120-foot length of track centered over the HRI, referred to as the island)
- Highway vehicle presence (a signal indicating if the technology detected a vehicle that was within the HRI limits and at least 7.5 feet but not more than 9.0 feet from the outside rail)

The TTCI engineering and instrumentation staff used an independent infrared automatic location device attached to test trains (one trigger at the front of the train, another at the rear) to determine actual or “baseline” train conditions. The infrared system included sensors placed at

each end of the 120-foot island, which would be triggered whenever a train entered or departed island limits. As such, it is important to understand that these were located where traditional track circuit island limits are placed, and may not represent the optimal locations where alternative detection systems would necessarily be located if installed at a revenue service site. Also, due to physical size some detector units, and in order to avoid interference it was not possible to place all systems' sensors exactly at the same location. Each vendor was asked about potential interference from other test technologies. If the potential for interference existed, the sensors were either spaced apart from others, or separate train passes were conducted with the other systems disabled. For purposes of comparison, however, all systems were evaluated relative to the baseline for detecting a train entering or departing the island length and limit locations.

5.1 TEST MATRIX

In order to exercise each system to its fullest extent, a range of train and highway vehicle configurations and operating modes were tested over the HRI. Each technology was evaluated for specific characteristics such as susceptibility to ground return currents and vibration detection. A test matrix used during previous Task Order 106 (Loss of Shunt) testing served as a guide and was modified to address suspected detection failure modes of the selected technologies. The final four test matrices exercised each technology to the extent feasible within the TTC environment. For example, testing was conducted in the October/November timeframe; thus, extremely low or high ambient temperatures were not encountered. However, train and highway vehicle configurations, speeds, and operating modes were controlled during testing.

Train variations consisted of four matrices using conventional rail bound equipment, including: normal train passes at 5-120 mph, variable speeds while traveling over the HRI, switching/change of direction over the HRI, and multiple trains on adjacent tracks. Railroads utilize specially modified highway vehicles for track inspection. They are called hi-rail vehicles and can operate on the road or rails. These vehicles are usually insulated to avoid activating highway grade crossing warning systems. As some of the alternative technologies might misinterpret hi-rail operations, additional evaluations included the use of these maintenance vehicles.

Specifics of each matrix can be found in Appendix C with a brief description of the train test configurations. Examples of Matrices 1 through 4 are as follows:

- Matrix 1 included constant speed passes approaching and through the HRI limits, with speeds ranging from 5 mph up to 120 mph.
- Matrix 2 included through passes with a series of accelerating/decelerating train moves.
- Matrix 3 was a series of typical switching operations, which included stop/reverse and stop/go types of moves.
- Matrix 4 was a series of test runs conducted with multiple trains using both the RTT and TTT. This matrix included trains moving in the same and opposite directions on parallel tracks at various speeds.

Testing for highway vehicle detection addressed system/technology capabilities to ascertain if a highway vehicle was located within the fouling limits of the HRI (see Figure 20). For purposes of this test, fouling limits were defined in the nearly square “box” within the HRI road limits between the outside rails of each track. The outer limits were defined as not more than 9 feet from the nearest running rail and inner limits no closer than 7.5 feet from the running rail. (As reference, the long rectangle parallel to the two tracks shown in Figure 20 indicates the detection zone limits for the train within the island limits.) A highway vehicle stopped or moving anywhere within the square box limits was to be detected. A vehicle approaching or stopped outside of these limits was not to be detected.

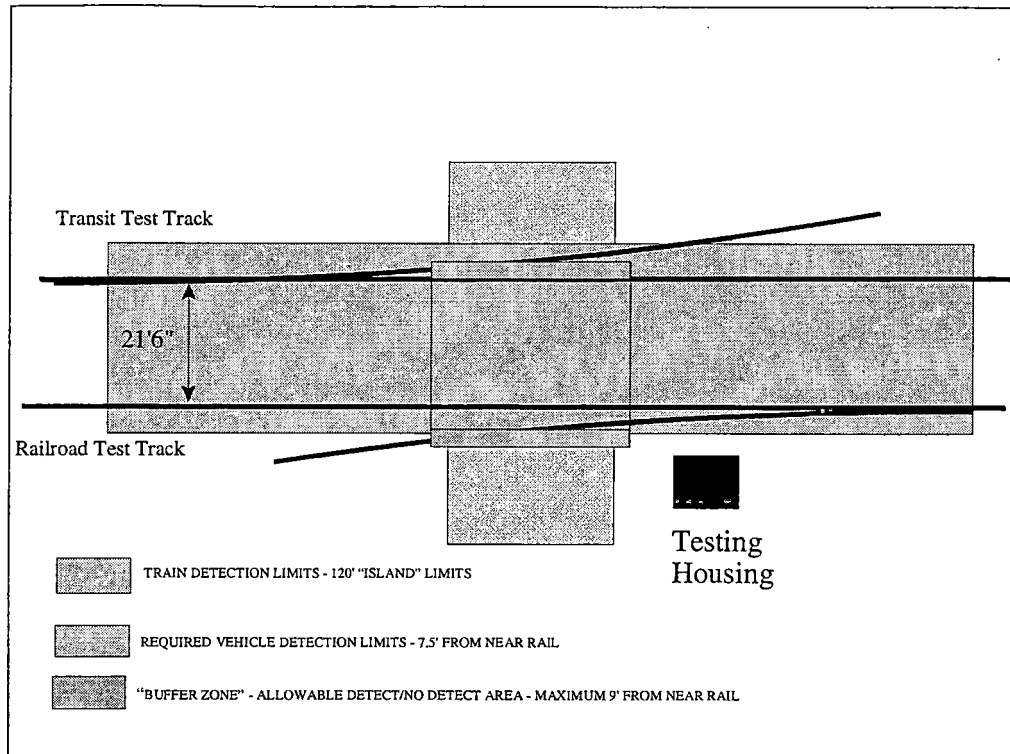

Figure 20. Post 85 Detection Zone Limits

Details of the highway vehicle test matrix can be found in Appendix D.

Matrices for highway vehicle/obstruction detection included static detection of highway vehicles and/or obstructions and dynamic detection of highway vehicles (moving vehicles). Highway vehicles ranged in size from large trucks to small motorcycles, other obstructions included pedestrians with and without a bicycle. Vehicles used for testing included:

- Small pickup truck
- Large pickup truck
- Large truck with trailer
- 8-ton flatbed (stake) truck
- Motorcycle

A bus was not available for testing, and a bicycle replaced the shopping cart stated in the RFTI. Obstructions included an overhanging load, a “dropped” appliance box, and a trailer. The overhanging load was two 136 lb./yd rail sections overhanging from a flatbed truck approximately 15 feet. The truck was pulled through the HRI from east to west and stopped when the rail sections were still protruding approximately 10 feet into the HRI.

For safety reasons, most highway vehicle tests were conducted without the actual approach of a train. All systems except for system 6 had to be manually armed in order to simulate a train approach and activate the vehicle detection system. This manual arming had the same affect as an approaching train; thus, vehicle detection systems were activated. In all cases, the island detection system was “armed” or active at all times regardless of whether or not the approach was activated.

6.0 RESULTS OF TESTING

Not all systems were intended to detect all variations (train approach, island occupancy, and/or highway vehicle detection). Initially all systems were turned on or “armed” simulating an actual installation before testing periods. As interference between alternative technologies using buried detection sensors was suspected, some runs of the test matrix were repeated with various combinations of systems turned on or off. A concern had been raised that systems using buried detection sensors might send signals to each other that could interfere with sensor operation. Results were similar to those seen previously; therefore interference concerns were ruled out and further testing was conducted with all systems armed. Table 1 summarizes the capabilities of the systems tested for train and/or highway vehicle detection.

Table 1. Summary of System and Train/Highway Vehicle Detection Capabilities

System	Train Approach	Island Occupancy	Highway Vehicle/ Obstruction
1	X	X	
2	X	X	X
3	X		
4	X	X	X
5	NOT EVALUATED		
6			X

The run summary tables in Appendix E (Tables 1-6) show results of all testing comparing performance as stated in the RFTI. Run matrix reference numbers are used as sub-indices for each table. For example, System 1 Matrix 3, data is shown in Table 1.3. For train detection this information includes approach warning time, time of island occupancy, and the difference between baseline and test system island occupancy. A separate sub-table is shown for each of the four test matrix variations of train operations and the hi-rail vehicle matrix. For highway vehicle detection an "X" indicator is used to identify when a vehicle at the HRI crossing was detected at the specified location.

Testing was conducted over a 3-week period starting at the end of October 1999. Due to track time availability most of the testing was conducted at night starting by 11 p.m. and continuing until 8 a.m. A summary of test days, dates, times, run matrix being evaluated, and weather conditions is included in Table 2.

Table 2. Date and Weather Conditions

Station: PUEBLO CO

Month: OCT

Year: 1999

	Temp	Temp	Temp		Wind	Wind
Day	Max	Min	Avg	Precip	Speed	Dir (Deg)
1	90	31	61	0	11.8	41
2	63	31	47	0	7.7	17
3	57	38	43	0	4.7	13
4	77	24	51	0	5	15
5	86	32	59	0	6.8	18
6	86	40	63	0	9	24
7	75	36	62	0	11.5	32
8	75	38	58	0	10.2	24
9	83	41	58	0	5.3	13
10	77	40	59	0	15	9
11	89	32	61	0	16	19
12	91	36	64	0	18	26
13	76	43	60	0	16	11
14	90	33	62	0	26	26
15	72	37	55	0	23	1
16	50	32	41	0.21	18	4
17	50	22	36	0	11	13
18	55	25	40	0.35	20	36
19	55	33	44	T	14	15
20	71	26	49	0	13	9
21	78	28	53	0	14	36
22	74	28	51	0	11	9
23	71	29	50	0	13	10
24	81	25	53	0	11	33
25	77	32	55	0	13	9
26	81	29	55	0	11	26
27	80	30	55	0	23	35
28	67	25	46	0	15	12
29	58	28	43	0.04	26	32
30	63	23	43	0	9	7
31	72	23	48	0	14	10

7.0 OBSERVATIONS FOR EACH SYSTEM

7.1 SYSTEM 1: TRAIN DETECTION ONLY

- Results are summarized in Appendix E, Tables 1.1, 1.2, 1.3, 1.4, and 1.8.
- Approaching trains were consistently detected by this technology; however, island occupancy times varied considerably for some train passes. During Matrix 1 testing 8 out of 10 of the slow (less than 10 mph) train passes were interpreted properly. But occasional passes (Runs 104 and 108) exhibited high delay times of 25 to 77 seconds over the baseline indicating the train was detected over the 120-foot long island longer than it was actually present. These differences became more common at all test speeds over 20 mph.
- During Matrix 2 testing (variable train speeds), island occupancy time exhibited large differences during passes when the train was slowing down (30-5 mph) while approaching and traveling over the island. Meanwhile accuracy was much improved during passes when the train was speeding up (5-30 mph) while approaching and traveling over the island.
- During some of the 14 switching moves conducted as part of Matrix 3 (e.g., run 302) a large difference from the baseline was exhibited, as system 1 indicated island occupancy before the train arrived at the HRI.
- Six parallel train moves were conducted in support of Matrix 4, all of which exhibited a nearly constant difference from the baseline of 3 to 6 seconds, regardless of the mix of speeds, direction or track.
- This system was not working due to equipment failure during hi-rail vehicle test passes.
- Most approach times on the TTT were at least 20 seconds or greater for all speeds, with the exception of Run 114, which provided only a 13.5-second approach warning at 50 mph. During Run 114 the system initially reported an approach then de-armed (dropped out) indicating the train was no longer approaching. The approach signal was not armed at the time the train arrived at the HRI. Other approach times, ranging from 37 seconds at 119 mph to over 730 seconds for one of the 5-mph runs were within the required 20-second minimum. Approach times on the RTT were 62 to 166 seconds at speeds up to 123 mph.

As train speeds increased, island occupancy time differences from the baseline increased. The largest difference for through train passes was 136 seconds at 123 mph. Most differences were about 15 to 25 seconds. This system was not functioning during hi-rail testing.

7.2 SYSTEM 2: TRAIN AND VEHICLE DETECTION

7.2.1 Train Detection

- Results are summarized in Appendix E, Tables 2.1, 2.2, 2.3, 2.4, and 2.8.
- No train passes were missed by this detection system. For through passes (Matrix 1, Table 2.1) the island occupancy times were generally 1.5 seconds or less (never exceeding 2 seconds) than the baseline. This difference was likely due to the physical placement of detectors, as the difference was proportionate to speed.
- During the variable train speed passes the difference from baseline times also did not exceed 2 seconds.
- Switching moves resulted in one difference (early release) of -4.5 seconds for Run 303, while all of the remaining passes differed by 2.5 seconds or less from than the baseline.
- Dual train moves, shown in Matrix 4, exhibited differences of 3 to 6 seconds from the baseline.
- When the hi-rail vehicle approached on the rail and continued through the HRI, it was detected and released. When the hi-rail vehicle was set on the rails at the crossing (approached from the road and departed on the rail), it was not detected. When the hi-rail vehicle approached on the rail and was set off at the HRI, the system detected it but continued to show occupancy after the vehicle departed the area. A manual island reset was required for further operation.
- Approach times on the TTT were within the 20-second requirement and ranged from 23 seconds at 80 mph to 420 seconds for one of the 5-mph runs. Approach times at 120 mph were about 26.5 seconds, but used a different set of sensors located on the RTT.

7.2.2 Vehicle Detection

- Vehicle detection variations evaluated are summarized in Tables 2.5, 2.6, and 2.7. in Appendix D.
- The static vehicle detection variations, shown in Table 2.5, indicated that all vehicles were detected between 7.5 feet and 9 feet from the west side of the crossing. However, on the east side a motorcycle was not detected until it was 5.5 feet from the near rail.
- Vehicles and combinations not to be detected (as stated in the RFTI) were pedestrians and pedestrians with a bicycle. Both were detected on the west side at the 9-foot limit, while on the east side a pedestrian was detected at 11 feet and the pedestrian with a bicycle was detected at 9 feet from the near rail.
- The dynamic vehicle detection variation results are shown in Table 2.6.
- All variations of vehicles moving within the HRI were detected.

- Dropped and overhanging load results are shown in Table 2.7.
- A dropped load was detected within the HRI limits. The system did not detect a 15-foot overhanging. For this run, the truck was operated over the HRI in an east-to-west direction with the load hanging out over the west end of the HRI.

7.3 SYSTEM 3: TRAIN DETECTION ONLY

- Results are summarized in Appendix E, Tables 3.1, 3.2, 3.3, 3.4 and 3.8.
- System 3 was intended to provide train approach and island departure times only. However, during eight runs the train was not detected on the approach. Out of the 49 runs, the island did not release upon departure 35 times. For those runs where a release trigger was detected, the 2-second requirement was always exceeded, and was typically in the 20-second range.
- The result tables for System 3 show several zero second approach times; thus indicating no time between the approach signal and the train arriving at the island. A zero second approach time indicates that the system failed to detect a train. This occurred eight times. Other runs (e.g., Runs 117, 118, and 119) show different approach times for the same constant speeds of 80 mph.
- Technology 3 exhibited several missed trains and failed to release the island (false alarm nuisance) for most runs. It did not detect hi-rail vehicles in all cases.

7.4 SYSTEM 4: TRAIN AND VEHICLE DETECTION

- Results are summarized in Appendix E, Tables 4.1, 4.2, 4.3, 4.4 and 4.8.
- No train passes were missed by this technology. The 25 through train passes, shown in Matrix 1, Table 4.1, indicated larger island occupancy differences from the baseline of up to 13.5 seconds during very slow (5-10 mph) passes, while the difference between baseline and system occupancy decreased to around 1 second as speed increased. This difference was primarily due to the physical location of the sensors with respect to the baseline island limits. As it was impossible to install the sensors from all the systems in the exact same location, it is expected that alternative locations would have improved comparisons from the baseline. No attempt was made to relocate sensors in order to adjust for these differences.
- Matrix 2 (Table 4.2) indicated the largest island occupancy time difference (up to 10.5 seconds) on two of the four passes between the baseline and the test system. The differences of approximately 10 seconds occurred during passes when the train was slowing (30 mph to 5 mph). During runs with the train accelerating from 5 to 30 mph, the differences were 3 to 4 seconds.
- Switching moves (Matrix 3, Table 4.3) indicated three occurrences of occupancy time differences of -37.5 seconds to 74 seconds. One exception, Run 305, exhibited a -245-

second difference between the baseline. During this test, part of the train remained on the crossing while the locomotive was backed away. The loops detected a departing train and released the island detection even though the island remained occupied.

- Island occupancy differences during Matrix 4, concurrent running of trains on adjacent tracks, were relatively low at 3 to 6 seconds.
- The hi-rail vehicle was detected and released when approached on the rail and continued through the HRI. When the hi-rail vehicle was set on the rails at the crossing (approached from the road and departed on the rail), there was no detection. When the hi-rail vehicle approached on the rail and was set off at the HRI, the system detected it but continued to show occupancy after the vehicle departed the area. A manual island reset was required for further operation.

7.4.1 General Observations: Train Detection

Out of 48 passes, island occupancy times were within 5 seconds of the baseline with 18 exceptions during switching and variable train speeds.

7.4.2 Vehicle Detection, Table 4.5 Only

The vehicle detection component of this system malfunctioned and was not operating during dynamic and dropped/overhanging loads testing.

7.4.3 Static Vehicle Detection

A pedestrian and a pedestrian with a bicycle were detected on the west side of the crossing at about 10 feet and 8 feet from the rail, respectively. On the east side of the crossing the pedestrian was detected approximately 8 feet from the rail. A pedestrian with a bicycle was detected at about 12 feet from the rail. The RFTI stipulated that the presence of a pedestrian was not to be detected.

All other motor vehicles were detected at approximately 10 to 12 feet from the near rail; however, this was outside of the limitations specified. The system displayed an internal failure and was not operational during the motorcycle passes; thus, no vehicles of any type were detected.

7.5 SYSTEM 5: TRAIN AND VEHICLE DETECTION

This system was not installed and adjusted by the vendor in time to be included in the testing conducted under this contract. Data may be collected at a future date replicating some or all test matrix requirements.

7.6 SYSTEM 6: VEHICLE DETECTION ONLY

- Results are summarized in Appendix E, Tables 6.5, 6.6 and 6.7.
- The intent of this technology was to detect highway vehicle traffic only. However, as the system was not connected to a train approach or island occupancy system, the presence of a train at the island was interpreted as a vehicle. Such detection was not considered a failure during this test, as an actual application would be integrated into a train island and approach system. It is assumed that such a system would detect a train arrival and departure on the island and override any indication from System 6 indications. At times, the system indicated a vehicle present on the HRI during the approach of a train even though no vehicle was present. These observations are presented as “information only,” as a future application of this technology would require an interface with approach and/or island occupancy systems which may eliminate such false detection; however, this was not evaluated during this test.
- Results of the 12 static vehicle detection tests are shown in Table 6.5. The system identified and indicated occupancy of all pedestrians, combinations, and vehicles. With the exception of the motorcycle (east side only), all vehicles were detected within the 7.5- to 9-foot requirement from the near rail. The motorcycle was not detected until it was about 5.5 feet from the near rail on the east side only.
- Results of the dynamic vehicle detection tests are shown in Table 6.6. All variations of vehicles moving within the HRI limits were detected.
- Results of the detection tests for dropped and overhanging loads are shown in Table 6.7. All dropped and overhanging load combinations were detected.
- Although intended for vehicle detection only, the system occasionally indicated a vehicle occupying the HRI when a train was on the approach circuit. Due to the requirement to clear the overhead catenary, sensors used by System 6 had to be mounted higher above the HRI pavement than desirable. This resulted in some loss of sensitivity and resolution; thus causing some vehicles to be detected after they were well within the detection zone. This phenomenon was only present on the east side of the HRI because the sensor had to be mounted at a height greater than desired. In all cases, any object placed or left within the island was detected by this system.

8.0 SUMMARY AND CONCLUSIONS

None of the combined train and highway vehicle detection systems performed with 100-percent accuracy when compared to baseline data for all test matrix combinations. The train only System 2 (count in/count out) technology was able to interpret all single-train approach and island occupancy times for Matrices 1, 2, and 3.

For Matrix 4 (dual track, multiple, simultaneous trains), interpretation of approach and island occupancy time differences was not straightforward as occupancy may not have always been continuous. This matrix was primarily intended to evaluate the logic of each system when installed on dual track territories and when two trains were present. In all cases, trains were detected on both tracks with System 3 as intended. The vendor for System 3 elected to remove sensors from the RTT. Thus, dual track detection results are not valid. Systems 1, 2, and 4 (dual train/dual track detection) all detected dual train moves approaching together and in opposite directions. However, the internal logic prevented accurate comparisons with baseline conditions. For example, if one train approach trigger occurred while another train (on the other track) was still in the island, a large difference might have been indicated when, in actual performance, the system would have operated the warning device properly.

Tables 3 and 4 summarize performance for train detection (Matrix 1, 2, and 3) and all highway vehicle/obstruction detection visitations. Performance is shown only for the categories that each system was intended to detect (e.g., Systems 2 and 4 are shown on both tables while Systems 1 and 3 are shown in Table 3, train detection).

The performance evaluations summarized in Tables 3 and 4 includes:

- Successful detection
- Critical failure
- Missed detection
- Nuisance alarm/false alarm

These are described as follows.

- **Successful detection:** A continuous positive signal indication at the receiving signal processing unit indicating the presence of a locomotive and/or a vehicle/obstruction in the detection zone, within the prescribed amount of time.

- **Train detection criteria:** A 20-second minimum for warning approach signal and 2-second maximum release time through island circuit. The warning time of 20 seconds prescribed in the FHWA's *Manual on Uniform Traffic Control Devices* was used as the criterion for successful detection.
- **Vehicle/obstruction detection criteria:** As specified by the RFTI, fouling limits consist of a box within the HRI road limits. The box's outer limits are not more than 9 feet from the nearest running rail and inner limits are no closer than 7.5 feet from the nearest running rail. Vehicles/obstructions within 7.5 feet of the nearest rail must be detected. Vehicles/obstructions greater than 9 feet from the nearest rail must not be detected.
- **ITS Information:** Separate section, not part of Tables 3 and 4 (only successful detections will be tallied):
 - Train direction (clockwise or counter-clockwise) interpreted correctly at the signal processing unit
 - Train speed (only for constant speed train movement matrices due to limited number of sensors in TTC installation) within 85 to 100 percent of actual speed
 - Train length (only for constant speed train movement matrices due to limited number of sensors in TTC installation) within 85 to 100 percent of actual length.
- **Critical failure:** The malfunction of the system or any component that prevents the system's signal processing unit from providing a continuous positive signal indicating train approach (approach warning of less than 20 seconds), or from providing a correct island release signal (releases before the train has cleared the island). If a system was not functioning for part of the test, only the runs that were successfully detected are shown as successful. Runs missed due to the system not functioning (i.e., turned off, failed, or not working) are not included in the critical failure count. For purposes of separating nuisance failures where train departure may not be properly detected, a critical failure is one that releases the warning system more than 10 seconds after train departure. This is considered critical as public reaction to gates/flashers remaining on for extended periods of time is a concern.
- **Missed detection:** Also to be considered a critical failure. This assessment is simply a narrowly defined subset of critical failures and is considered as the absence of a continuous positive signal indication at the signal processing unit indicating the presence of a locomotive and/or a vehicle/obstruction in the detection zone, within a prescribed amount of time. This includes missed approaches.

- **Nuisance Alarms (NA) and False Alarms (FA):** Combined into one category (NA/FA) because FAs could not be reliably distinguished from NAs during testing at TTC even though there is a definite theoretical difference between a NA and a FA.
 - A Nuisance Alarm is a positive continuous signal indication at the receiving signal processing unit produced by a signal source other than the intended signal or detection equipment. The NAs of concern during testing were those caused by undesirable detections such as pedestrians, bicycles, tumbleweeds, birds, and bats. This includes the detection of a train or vehicle when one is not actually present, and the activation of the train approach before the train reaches the approach limits.
 - A Nuisance Alarm rating was also given for island release times of more than 2 seconds but less than 10 seconds. If the island released within this time it would appear as a nuisance to the motorist, but not likely be a critical failure.
 - A False Alarm is positive continuous signal indication at the receiving signal processing unit produced by a source other than the desired signal source (i.e., the system detected a train on one track when the train was actually on the other track). It is usually the result of a basic design flaw.

Table 3. Summary of Train Detection Performance

TRAIN MOVES: MATRICES 1-3

	SYSTEM 1		SYSTEM 2		SYSTEM 3		SYSTEM 4	
	A	I	A	I	A	I	A	I
SD	40	15	43	43	20	2	41	15
CF	1	20	0	0	0	37	0	9
MD	0	0	0	0	8	0	0	0
NA/FA	0	5	0	0	1	0	0	17
Notes: A – Approach indication I – Island indication SD – Successful detection CF – Critical Failure MD – Missed detection NA/FA – Nuisance alarm, false alarm								

Table 4 – Summary of Vehicle/Obstruction Detection

OBSTACLE DETECTION

	SYSTEM 2			SYSTEM 4			SYSTEM 6		
	SOD	DOD	DLD	SOD	DOD	DLD	SOD	DOD	DLD
SD	16	41	2	11	*	*	17	41	4
CF	0	0	0	0	*	*	0	0	0
MD	1	0	2	2	*	*	1	0	0
NA/FA	1	0	0	4	*	*	0	0	0
SOD - Static Obstacle Detection DOD - Dynamic Obstacle Detection DLD- Dropped Load Detection System 4 Obstacle detection not functional - No Data collected.									

8.1 TRAIN APPROACH DETECTION

The train approach signal is used to activate the warning system and must be armed at least 20 seconds prior to the train arrival. System 1 exhibited one approach warning of less than 20 seconds, while System 3 exhibited eight failures to detect train approach out of 45 runs. Systems 2 and 4 exhibited no train approach failures. In all cases, the fixed sensors used during these tests did not provide constant warning times, with slower trains resulting in longer approach times and fast trains providing shorter approach warning times. Constant warning time was not a performance requirement stated in the RFTI.

8.2 ISLAND OCCUPANCY

The island occupancy time is an indication of how well the system interprets the presence of a train at the HRI limits. This information is essential in providing a release indication to warning systems after train departure. With the exception of System 2, none of the technologies were able to consistently match the baseline system for accuracy in detecting train arrival/departure within the island limits. In some cases this difference may be due in part to “forcing” a technology to detect a train at limits traditionally set by track circuits. As sensors were placed at or as near to traditional island limits as possible (to allow comparison with a known baseline), the detectors may not have been optimally located as they would be in a stand-alone system at a revenue service site. It should also be noted that in some cases these differences were variable indicating inconsistent interpretation. System 4 island occupancy became shorter as the speed of the trains increased, indicating the potential of a sensor positioning offset.

8.3 STATIC HIGHWAY VEHICLE DETECTION

Highway vehicles stopped within the HRI and within detection limits (7.5 to 9 feet from the near rail) must be detected in order to provide information to warning systems of potentially unsafe conditions. Such an indication may be used, for example, to release exit gates of a four-quadrant system to allow a trapped vehicle to escape. It would be highly desirable, however, if the sensitivity of such systems did not detect pedestrians and other smaller objects to avoid “false” calls.

All technologies (Systems 2, 4, and 6) detected pedestrians and vehicles statically within the HRI though there was some variation among these systems on how far from the HRI near rail limits various objects were detected. All systems indicated a detection/trigger when objects were at least 5.5 feet away from the near rail, while most detected within the 7.5- to 9-foot zone as required in the RFTI. Occasionally some objects were detected up to 12 feet from the near rail. As the differences were not symmetrical to both sides of the crossing some bias in sensor location may be at fault. In all cases the systems detected pedestrians when at or in the HRI limits, although the requirements in the RFTI stated they should not be detected.

8.4 DYNAMIC HIGHWAY VEHICLE DETECTION

Moving vehicles that enter into the detection zone and then continue or change direction should be detected when within the HRI. Upon their departure the detection system should release. Systems 2 and 6 interpreted all combinations of moving vehicles properly. The vehicle detection component of System 4 failed and no data was collected for dynamic vehicle detection performance.

8.5 DROPPED AND OVERHANGING LOADS

Items dropped within the HRI or overhanging from vehicles could be struck by passing trains. Advance detection of such items could improve HRI safety. Systems 2 and 6 detected dropped loads, while only System 6 was able to discern an overhanging rail within the HRI. The vehicle detection component of System 4 failed and no data was collected for overhanging or dropped load detection performance.

9.0 RECOMMENDATIONS

All systems designed for vehicle/obstruction detection detected pedestrians within the island/roadway limits. The RFTI indicated that pedestrians should not be detected. The

desirability of such detection, however, has not been fully determined. There could be benefits to such detection, depending on the ultimate use of the information. It may not be desirable to activate the retracting operation of barriers and other warning systems when pedestrians are present. On the other hand, detection of pedestrians within road crossing limits may enhance safety in congested areas, thus the ultimate need for the detection signal is required.

9.1 ADDITIONAL INFORMATION: ITS

Detection systems selected for this program (Task Order 123) were also evaluated for their ability to provide additional information regarding train condition, speed, direction, and length. Such information would be valuable as input information for an Intelligent Transportation System (ITS) package.

Data collected by each system during evaluation for train and highway vehicle detection was further evaluated after the completion of tests to determine if ITS-related information was contained and, if so, how accurate was this information. As this effort was supplemental to the original scope of work and not included in the RFTI, no requirements or specifications were included.

A summary of ITS issues is included as Appendix F. Data for those systems with various ITS capabilities (Systems 1, 2, and 4) indicates the following:

- Train direction (clockwise or counterclockwise) is detected reliably
- Steady state speeds are detected with sufficient accuracy (generally within 2 mph)
- Train length accuracy varied with speed and was the least consistent, with large variations at the same speeds

(blank)

**APPENDIX A:
LIST OF CROSSING COMPONENT ADVISORY
TEAM MEMBERS AND AFFILIATIONS**

MEMBER	AFFILIATION
A. Carroll, (C ² AT Chair)	John A. Volpe National Transportation Systems Center
J. Gordon	John A. Volpe National Transportation Systems Center
D. Plotkin	Federal Railroad Administration
J. Smailes	Federal Railroad Administration
M. Onder	Federal Highway Administration
F. Small	Federal Highway Administration
A. Polk	Jet Propulsion Laboratory
K. Holt	National Passenger Rail Corporation (Amtrak)
R. Porath	Canadian National Railroad
M. McNichols	CSX Transportation, Inc.
J. Smith	Norfolk Southern Corporation
C. Taylor	Transportation Research Board/Association of American Railroads
R. Reiff	Transportation Technology Center, Inc.
S. Gage	Transportation Technology Center, Inc.

Request For Technical Information

Highway-Rail Intersection: Train Presence and Highway Vehicle Detection

Transportation Technology Center, Inc.

January 29, 1999

1.0 PURPOSE

On behalf of the Federal Railroad Administration (FRA), Federal Highway Administration's Intelligent Transportation System (ITS) Joint Program Office (FHWA/ITS/JPO) and the North American railroad industry, the Transportation Technology Center Inc. (TTCI) is issuing this Request for Technical Information (RFTI) to identify and evaluate safe, reliable, cost-effective components and/or system technologies for train and/or highway vehicle presence detection at highway-railroad grade crossings (Highway-rail Intersection, HRI). Potentially, reliable, cost-effective detection components and/or systems identified through this process could be used in other applications. Examples include alternatives to conventional railroad track circuits for HRI warning device control, for positive and/or automated train control, information supplied to Traffic Management Centers, communication to local traffic control signals, and for use in Intelligent Transportation Systems (ITS).

The primary objectives of this research are:

1. Improved Train Detection

1A: Improved train presence detection at the HRI detection zone (railroad terminology, island circuit) - evaluate prototypes of technologies that will improve train presence detection within the HRI detection zone (railroad terminology, island circuit) limits and provide a release signal within 2 seconds after train departure.

1B: Improved train presence detection on approach to the HRI (railroad terminology, approach circuit) - For complete "stand alone" systems, evaluate prototype technologies to provide a constant approach warning time of a minimum of 20 seconds at all train speeds (up to 125 mph) and operations. The approach warning technology must provide a signal to activate the HRI warning system a minimum of 20 seconds prior to the train arriving at the HRI limits. Enhanced advance train detection systems that provide train speed and length information is encouraged.

2. Highway vehicle detection - Evaluate technologies that can be used to detect highway vehicles within the HRI detection zone limits and/or fouling of railroad clearances. Enhanced highway vehicle detection systems that provide speed and length information are encouraged.

Consideration will be given to technologies that address any or all of these objectives. An advisory committee entitled, HRI "Crossing Component Advisory Team" (C²AT) with representatives from railroad, highway, transit and Federal Rail and Highway agencies has been formed to provide technical and policy guidance for this project. The initial phase of this program will include a technical review by C²AT of vendor proposals that address performance parameters included in this document. The technologies selected by C²AT will promulgate an invitation to the vendor(s) to participate in demonstrations and screening tests to be conducted at the Transportation Technology Center (TTC), Pueblo, Colorado, and will be considered for supplemental funding for installation of devices on the TTCI facilities. These screening tests will simulate a variety of field conditions, train and highway vehicle operating modes. These tests are intended to identify potential operating limitations of the selected technologies. Pending results of the screening evaluations, there is a potential for follow on work in the form of in-service operational field demonstrations that would be conducted at actual HRIs on revenue railroads.

1.1 Improved Train Presence Detection:

Reliable train presence detection systems are essential to activate and control warning systems at HRIs for use by highway motorists and pedestrians to determine whether trains are approaching and occupying the HRI. There are approximately 60,000 HRIs in the U.S. with active warning devices and 200,000 passively warned HRIs.

Shunting of track circuits has provided a means of detecting train presence since the basic DC track circuit was invented in 1872. It is still the principal means of train presence detection, and is used worldwide, with some variations to enhance performance. Some variations include AC track circuits, DC coded track circuits and audio

frequency overlay circuits. As presence detection of trains moves from track circuits (railroad terminology, non-shunting circuit technologies) to technologies such as transponders for example, and as these systems become more reliable and less expensive in the US, such alternatives for detecting train presence may also be used to supplement conventional track circuits to improve performance. Currently these types of systems are used internationally for detecting train presence in a variety of applications, including HRI warning systems.

Train speeds can vary considerably, thus the distance a HRI warning device is activated prior to the arrival of a train may vary. Various technologies are currently in use to provide constant warning time to the HRI warning system. This warning time can be affected by train speed, train acceleration and de-acceleration, and in cases of slow trains, train stopping, and starting and changing direction. Refer to the Appendices for additional background information about HRI warning systems and train presence detection.

1.2 Highway Vehicle Detection

The advent of four-quadrant gates and barrier systems for providing additional safety to highway vehicles at HRIs requires additional sensing technologies to ensure safe and reliable operation. The complete activation of a four-quadrant gate or barrier system will block both entrance and exit to the HRI, thus additional information as to the presence of a highway vehicle within the HRI when a train is approaching is needed. This may include information regarding the presence of a vehicle that has not fully exited the HRI limits. Such information could be used to activate or release the exiting barrier and allow the highway vehicle to depart and not be trapped within HRI limits and/or could be used to inform the railroad of obstructions in the HRI limits.

2.0 PERFORMANCE GOALS

Information is sought on safe, reliable, cost-effective alternatives to detect train approaches to and/or train presence within standard HRI limits. For evaluations at the TTC, the train presence limits within the HRI are 120 feet in length, however in revenue service this length can be 120 feet to 300 feet. During TTC evaluations the presence of highway vehicles on or within physical fouling limits of the HRI warning system will also be monitored. For the TTC evaluations, highway vehicles shall be detected at least 7.5 feet outside of the near rail from each track but no further than 9 feet from the near rail of each track, and for the 26.5 feet between the outside rails of the two tracks. Figure 1 depicts the overall test zone, while figure 2 details the road crossing and highway vehicle detection zones. Public road crossings may have detection highly variable detection limit requirements. The intent is to select the most promising components and/or systems for test and evaluation.

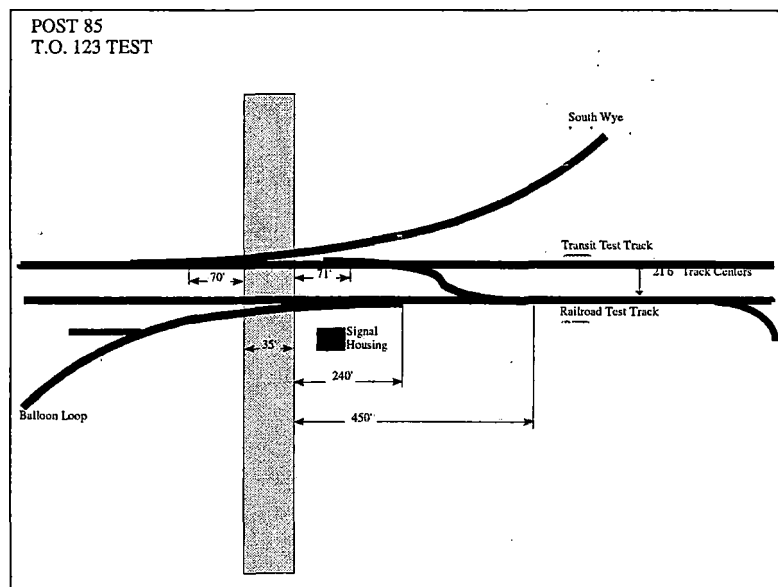

Figure 1: Overall site layout showing tracks, turnouts and road crossing.

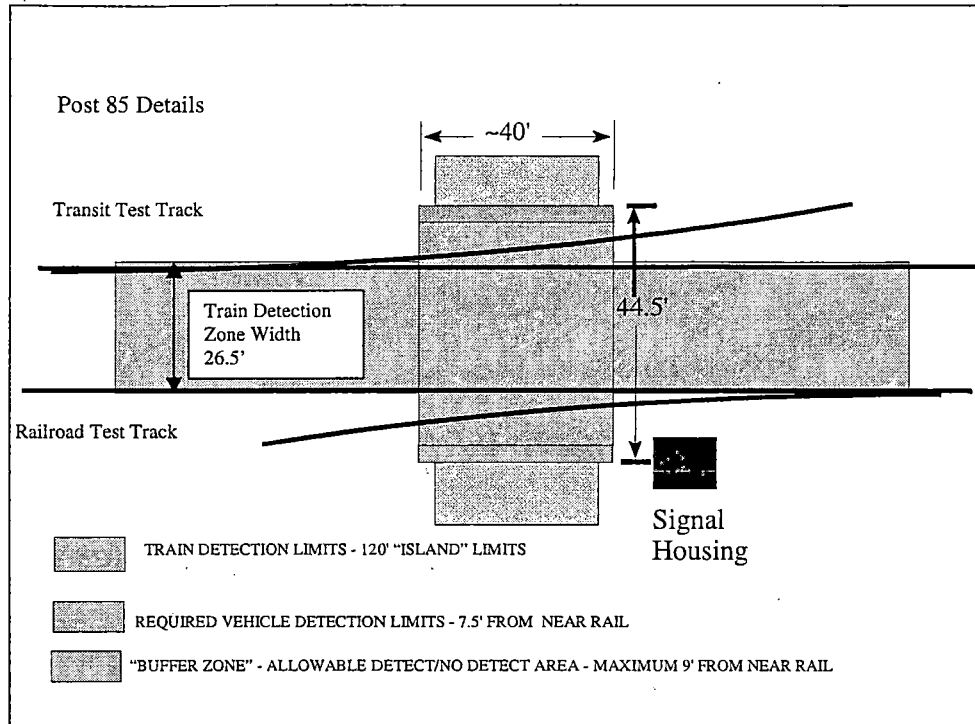

Figure 2: Detail of road crossing showing island limits and vehicle detection limits

Following is a description of the performance goals for these systems.

2.1 Functional Requirements

The functional requirements outline how the technology must operate in the field and interpret train and highway vehicle approach, presence and departure. Also included in this section is other information regarding anticipated operating environment, types of equipment expected to be encountered, track conditions, operating reliability and maintenance issues.

2.1.1 Train presence detection

The train presence detection system shall be capable of detecting the presence of a train of any configuration in any situation, within the parameters of the operational environment, as described below. The system shall be capable of communicating the detected train presence to a HRI warning device. Further, the system shall be capable of determining when the train has left the specified area and communicating that information to the warning device within two seconds of train departure in order to terminate the equipment's activation cycle. To evaluate approach performance, train operations will be conducted at speeds up to 160 mph, stop and start, and approach and reverse to simulate a range of potential operating conditions over both single and double track locations. Systems must provide a minimum of 20 seconds advance warning to the HRI warning system for all train speeds of up to 125 mph. For additional information regarding approach timing refer to the FRA signal regulations, CFR 40, Part 234.225 "activation of warning systems". System specific software performance to interpret sensor signals will be monitored.

2.1.2 Highway Vehicle Detection

The highway vehicle detection components and/or systems shall be capable of detecting the presence of a highway vehicle (this may include cars, trucks, buses, etc) within the roadway limits of a HRI. Other objects, including but not limited to motorcycles, bicycles, shopping carts, and trailers will be included in the test process to determine how the detection system interprets their presence.

For evaluations to be conducted on the HRI located at the Transportation Technology Center, vehicles must be detected when any portion of the vehicle body or wheels are a minimum of 7 ½ feet from the nearest rail, and not be detected when any portion of the vehicle is 9 or more feet from the nearest rail. At field installations these distances may be different due to local conditions, thus these dimensions are not to be considered a fixed standard. Trains passing along adjacent trackage shall not be detected as blocking the track. The technologies will be monitored for an output signal (go/no-go) as to HRI condition. System specific software to interpret sensor signals will be evaluated.

2.2 Operational Environment

2.2.1 Detection Zone

2.2.1.1 Train presence within the HRI (railroad terminology, island circuit) and HRI approach limit detection

Trains must be detected immediately upon entering the HRI detection zone, (railroad terminology, island limits), and release within 2 seconds after departing the HRI detection zone (railroad terminology, island limits), regardless of train direction, or change in direction or speed or more than one train entering the HRI from multiple tracks. The minimum length of the detection zone for evaluations to be conducted at the TTC will be 120 feet and a width of 26.5 feet, covering both tracks, as shown figure 2. Field applications, however, may require longer or shorter detection zone lengths and widths.

For systems that include an approach option, trains must be detected in advance of the HRI limits to provide an approach signal to the HRI warning system at least 20 seconds in advance of the train arrival to the HRI limit. The 20-second warning is required for trains up to 125 mph along with slower approaches (2 mph), trains which are accelerating or decelerating, and stop/start and change of direction. During TTC evaluations, additional train speeds of up to 160 mph will be operated

2.2.1.2 Highway Vehicle Detection

Vehicles must be detected if they are moving or static within the HRI limits described in 2.1.2 Refer to figures 1 and 2 (section 2.0) for highway vehicle detection limits. If a vehicle departs the HRI limits, the indication shall provide for a clear HRI within 1 second of vehicle departure. Likewise, any impingement into the defined space at any time shall be identified within 1 second.

2.2.2 Track Structures

A wide variety of track is in service, which must be accommodated by the train and highway presence detection systems. Variations occur in types and quality of ballast, ties, rail, highway and HRI pavement, HRI materials and associated hardware. HRI limits may be at or near mechanical track joints, which utilize angle bars and bolts. The presence of gaps at rail ends must be considered. Contiguous multiple HRIs along a single or multiple track line may be present within four hundred feet of another active HRI. Multiple, parallel tracks may also be present as within the test regime planned for TTCI testing, with distance between track centers of as little as 11 feet. In addition, turnouts, crossing frogs and other components may be placed within HRI limits. If the technology proposed includes auxiliary approach circuits, these circuits must operate when nearby turnouts are set for either mainline or diverging directions. Reference the American Railway Engineering and Maintenance-of-Way Association's (AREMA) Manual for Railway Engineering for more detailed information on track structures. The AAR Communications and Signal Division's Signal Manual provides additional details in Section 3.1.20 on related electrical issues.

2.2.3 Train Consist and Highway Vehicle Characteristics and Speeds

Characteristics of trains, individual freight and passenger cars and highway vehicles that need to be detected vary greatly. The trains range from long, slow bulk commodity trains and vehicles to short high speed trains and vehicles. Detection must accommodate freight trains operating as fast as 80 mph and passenger trains operating as fast as 125 mph. TTC evaluations will include train speeds of up to 160 mph and highway vehicle speeds up to 40 mph. Detection and operation during slow train and vehicle passage is also required. Slow speeds of less than 2 mph, along with stopping, starting, and change of direction must be accommodated. Additionally, the system must detect the presence of a single train car standing or moving in the HRI. Trains may accelerate or decelerate at rates up to 3.2 feet per second per second, while highway vehicle acceleration and deceleration rates may be up to 17.6 feet per second per second. The transportation equipment may enter the detection zone and leave the zone via the point of entry, or stop for any length of time and then proceed.

Trains may be as short as 40-foot single-unit switching locomotives with or without one or more cars. They may be as light as 5,000 pounds per wheel for empty aluminum coal cars or innovative intermodal equipment. (These assumptions do not consider trends towards future lighter axle loads or the presence of hi-rail and similar maintenance-of-way equipment.) Equipment that is intentionally insulated, such as certain work or hi-rail vehicles, will be operated and in some cases be stopped, "set-off" and removed without making a complete pass through the HRI limits. These types of equipment will not provide an approach indication from conventional HRI warning systems. Axles may be spaced as far apart as 70 feet and as short as 5 feet. Some equipment may have split-axle. Any mix of equipment types may be found in any given train consist. Car shape and physical profile may vary, with both fully loaded and empty flat and spine cars, high or low floor cars, and a variety of paint, materials, and surface finish color on car side surfaces. Variations in wheel profiles also occur, due to variations in both design and wear. Also, wheel flats may occur on random cars. Impact loads of 90,000 lbs. from flat wheels will be encountered (this limit will vary with changes in AAR interchange standards), however occasional impacts exceeding 100,000 lbs. can occur.

Highway Vehicles

Highway vehicles that need to be detected will include automobiles, small and large trucks, busses, mobile homes, tractor-trailer combinations with and without loads, truck trailers with variable overhang and overhanging loads, crane booms, and motorcycles. Cargo dropped by highway vehicles in the HRI zone will also be simulated. Highway vehicle shape and physical profile may vary, with both fully loaded and empty vehicles, busses or trucks, and a variety of paint, materials, and surface finish color on the vehicle side surfaces. Highway vehicles will be moving at a maximum speed of 30 mph, or could also be stopped on the HRI. They also can be moving in forward or reverse directions such as the train consists

2.2.4 Highway Traffic Operational Requirements

While safety is the highest priority, delays to highway traffic due to activation of HRI warning devices must be minimized. In general, systems shall not maintain activation of highway gate/signal operation more than two seconds after trains have cleared HRI limits.

2.2.5 Environmental Conditions

The equipment detection system must operate in the range of conditions found throughout the North American continent. These include shock and vibration and extremes of weather such as temperature, lightning, precipitation (rain and snow, ice formation), wind airborne dust, or variations in transmissivity. The technology must operate under a range of temperatures from -40 degrees to 160 degrees Fahrenheit. A wide range of environmental contaminants is also present at various track and highway roadbed locations, including ground moisture, spilled lading (e.g., coal dust, iron ore dust, taconite, chemicals, grain), leaves, sand, mud, diesel fuel, greases, iron oxides, and highway salt. The AREMA Signal Manual provides additional details in Sections 3.1.20 and 11.5.1.

2.2.6 Electro Magnetic Interference and Susceptibility

Installations may be subject to electromagnetic fields from radiated and conducted emissions and must not interfere with other equipment and locomotives already in use. This includes interference from or to: locomotive traction and speed control systems (including speed/wheel slip radar devices), AC and DC ground to rail return stray current (up to 70 amps AC/40 amps DC), in-train hotel power cables and lines, and 3rd rail/overhead traction power. Guidelines for the limits on the electric field strengths encountered may be obtained from ATCS Specification 110, "Environmental Requirements," Revision 3.0, March 1993.

2.3 Interfaces with HRI Warning Devices

The ability to interface with existing HRI warning equipment is desirable. Since there are multiple types of existing HRI devices, and there is no standard electrical or logical interface, this ability is not a requirement for responding to this RFTI. However if there are specific interface limitations, or the system will not interface with existing equipment, these limitations must be clearly stated. Alternative means of approach detection must be provided.

Current HRI warning systems are capable of operating using a backup low voltage power supply, since a backup power source of all systems is required by law. Proposed equipment must be able to self reset or otherwise recover and operate properly, without excessive downtime, from power supply failures or other interference.

2.4 Performance Monitoring

Performance will be monitored under a variety of train and vehicle configurations operating over and near the HRI. Depending on the application that a particular technology is addressing (train presence detection, train approach detection, highway vehicle detection, or a combination of two or more) during TTC testing a log will be maintained documenting the occurrences of:

- * failure to detect
- * false detection
- * late detection or release
- * intermittent release and re-detection
- * failure to release
- * false or premature release
- * variable release times
- * approach warning time
- * nuisance alarms (extended approach warning)

The extent and duration of failures is also significant and must be considered, since longer-duration failures are usually more critical than shorter ones. System failures and time to repair will be logged.

2.5 Maintainability

Ease of maintenance shall be evaluated. Tasks included are fault diagnosis, fault isolation, removing and replacing necessary components, and performance verification testing. Built-in diagnostics may be helpful in meeting this requirement.

2.6 Costs

As is generally the case, systems that have a lower life cycle cost will be preferred, other factors being equal. This is particularly relevant because of a desire to implement the solution at a maximum number of HRIs in a relatively short time period. Approximate installation costs must be provided to determine possible Federal contributions to the aid in the installation of selected technologies at TTCI.

3.0 INFORMATION REQUIRED

Suppliers with systems that will meet the parameters stated above are requested to respond to this RFI by providing the following information.

3.1 Proposed Solutions

3.1.1 Description of Proposed System - Theory of Operation

Provide a summary functional description of how the proposed presence detection system will operate. This summary description should be no more than five pages of narrative plus any supporting illustrations, graphics, or photographs. The area of application must be stated, that is:

1. improved train presence detection within the HRI limits (railroad terminology, island circuit) only and 2 second HRI warning device release
2. improved train presence detection on approach to the HRI (railroad terminology, approach circuit) only and logic to provide complete 20-second approach detection
3. highway vehicle presence detection only
4. combination of items

Selection will be based on technical merit.

3.1.2 Current Status of Proposed Solution

3.1.2.1 Current Installations

Please state where your system(s) are installed (one or two examples only), and how long they have been in service (if applicable).

3.1.2.2 Operational Conditions

Please state what the volume of rail traffic is and what the operational conditions are at the site(s) described above (if applicable).

3.1.2.3 Current Performance

Describe the performance of the system(s) described above (if applicable). Include maintainability and reliability mean time between failures (MTBF) and duration of losses of train presence detection in your response.

3.1.2.4 Test Results

Include results of any testing that supports your statements describing your system's performance, or that would provide evidence of your system's ability to meet the performance goals discussed in Section 2.

3.1.3 Expected Performance

3.1.3.1 Reliability

Discuss the level of reliability that you project for your system, if different from the current performance indicated in 3.1.2.3, above. Quantify in terms of MTBF and duration of losses of train presence detection. Identify the differences between your proposed system and current operational systems that would contribute to the difference in MTBF, if applicable. Also address the tradeoff that is available between reliability and cost for your system.

3.1.3.2 Maintainability

Discuss the level of maintainability that you project for your system, if different from the current performance indicated in 3.1.2.3, above. What will be your system's maintenance requirements? (Specify frequency of repairs, mean time to repair, labor hours, skill level required of maintenance technicians, built-in diagnostics, estimated annual cost per device.)

3.1.3.3 Interface

Describe how your system will interface with existing warning systems (physical/electrical/logical interface - if known). This includes interference with existing approach and HRI systems. If applicable, provide a statement to the extent that the proposed technologies determine train and/or vehicle type, speed and/or length and whether these systems need to be monitored.

3.1.3.4 Assumptions

What conditions have you assumed that may affect the performance of your system (e.g. climate, train speeds, train frequency, maintenance)?

3.1.3.5 Environmental Interference

What is the susceptibility of your system to environmental interference? Specific issues include electromagnetic energy generators, such as AC traction motors and electrical storms, climatological conditions, and structural interference. Also include a description of any electromagnetic radiation your system may generate to allow technical reviewers to determine if there is a potential to interfere with railroad communications or signal systems.

3.1.3.6 Other Advantages and Applications of Your System

Please address any other advantages or applications of your system. For example, provide a statement to the extent that the proposed technology determines train and/or highway vehicle type, speed and/or length.

3.1.3.7 Susceptibility to Damage

Indicate areas where hardware could be susceptible to vandalism, train-induced vibration, and/or dragging equipment, and how the technology is designed to go "fail safe" should this occur. Also include how the system can notify maintenance personnel when damage has occurred. This is to also include damage, blockage or other interference from snow, ice buildup, fog, rain, wind, blowing debris or other contaminants that are part of the railroad field environment.

3.1.4 Installation Schedule

Indicate when you would be able to provide and install one or more prototypes for screening and evaluation tests at the TTC. The vendor shall provide a component and/or system and labor for installing it at TTC for evaluation. When screening tests are completed, the vendor shall remove equipment. Electrical power is available. Specify your systems power requirements, both steady state and peak, and normal operating voltage.

3.1.5 Costs

Provide estimated costs for your system in production quantities. This estimate should clearly state what components and/or systems it does or does not include.

For installation at the TTC, the vendor is required to submit proposed installation costs of the component and/or system for this evaluation. Cost estimates shall consider all requirements, access, training and repair items shown in section 4.2. For installing systems in support of evaluation, the C²AT will consider supplementing these costs for selected components and/or systems.

3.2 Capabilities to Develop Solution

Summarize your previous work in this field, including a list of references or customers, and the nature of the system developed for each. Describe your ability to design and manufacture comparable systems and provide systems integration to other HRI warning devices and systems and enhanced train (PTC) and traffic control (ITS) systems.

4.0 ROLES AND RESPONSIBILITIES

This project is under the guidance of a joint government-industry HRI crossing component advisory team (C²AT). The C²AT is comprised of representatives from the Federal Railroad Administration (FRA), the Federal Highway Administration (FHWA) and the Intelligent Transportation Systems Joint Program Office (FHWA/ITS/JPO), American Association of State Highway and Transportation Officials (AASHTO), Federal Transit Administration (FTA), Institute of Traffic Engineers (ITE), Transportation Research Board (TRB) and the railroad industry. The Committee members are knowledgeable in such areas as railroad operations, communication and signal systems, train control systems, freight car and locomotive design, track system design and maintenance, highway operations and maintenance, and HRI safety.

4.1 The C²AT Role

This committee will select systems for test, review test requirements, provide test oversight, review test data, and review the final report.

4.2 Supplier Responsibilities

Suppliers shall provide the information that is requested. Those suppliers whose systems are selected for evaluation and testing shall furnish, install, and maintain test equipment. Access to field sites for maintenance, repair or adjustments by vendors will be accomplished only after confirmation with TTCI personnel, and through coordination with the appropriate field representative. Additionally, they shall provide field engineering personnel during testing to ensure that systems have been installed correctly and are working properly. All supplier representatives will be appropriately dressed with required safety equipment and will be required to attend a safety class at TTC and for each railroad field test site at which their equipment is installed.

It is the intent of AAR to maintain the confidentiality of proprietary information. However, AAR cannot guarantee confidentiality. Therefore, suppliers that wish to protect any proprietary rights, including but not limited to patents, trade secrets and copyrights, are advised that they must take all steps necessary to do so.

5.0 SELECTION PROCESS

Responses will be evaluated by the C²AT based on its examination of the information provided. The committee will compare the expected performance of each supplier's component and/or system with the requirements and performance goals that have been identified in this document.

The committee will evaluate the suppliers' ability to meet the requirements of this effort according to the following criteria:

Meeting performance parameters outlined in this document

Projected reliability of the candidate component and/or system;

Projected maintainability of the candidate component and/or system;

Supplier's adherence to schedule, including commitment to providing equipment to dates stated in this document

Supplier's provision, installation, and maintenance of equipment for testing (The C²AT will consider supplementing costs of installation at TTC);

Supplier's provision of technical support for testing.

Implementability: ease of application, compatibility with existing systems and integration with potential future train control (PTC) and Intelligent Transportation Systems (ITS).

Systems that already have undergone beta testing or have been demonstrated in-service will receive preference in the evaluation process relative to those that have not.

6.0 TEST PROTOCOL

The following is a brief summary of the test protocol that will be used to evaluate candidate detection systems.

6.1 Test Procedure

Suppliers of selected candidate detection components and/or systems shall each furnish and install the detection system, including a complete technical description of the theory of operations, for preliminary testing and screening at TTC in Pueblo, Colorado. Suppliers would not need to furnish entire warning systems, but only the detection components and/or systems that would provide a signal to control the actual HRI/approach limit warning devices and/or notification of a vehicle blocking the track. During the TTC tests, only the system signal output will be monitored (on/off) for each of these conditions. The output of the detection systems would be recorded during this preliminary testing. At this stage, the detection systems will not be used to control actual HRI warning devices. Sensors to determine train and/or highway vehicle type, speed and/or length will be monitored if the technology is part of the system being installed.

The tests will be conducted using a variety of on-track equipment including a train consist composed of a range of freight cars from very light empty cars to very heavily loaded cars and both two- and four-axle cars, work equipment and hi-rail vehicles. The train consist will pass the HRI at speeds ranging from 2 mph to 160 mph. A variety of movements, designed to test the limits of the components and/or systems, will be used including stopping, backing, switching (including consist changes) and other movements that maybe deemed useful for the evaluation of a specific technology.

Likewise, a variety of highway vehicles will be utilized to determine system sensitivity for detection. This will include a range of vehicles (wheel bases, overhang, load, etc).

The data collected will be used to estimate each system's capability to consistently and reliably detect the presence of each car and locomotive in a section of track and/or highway vehicle within the HRI limits, and for train movements such as those described above under a variety of outside influences (including EMI, ground fault currents; and passing train influences). Once the prototype is installed at TTC, a three stage test procedure will be conducted as follows:

1. Up to a two week period will be allowed for each vendor to install, checkout and debug each respective system. During this period, a limited number of train passes will be provided by the program to assist in the installation process.
2. A one week preliminary test will be conducted. During this period, no upgrades or changes will be permitted. After this test, results for each system will be reviewed with the supplier. Following the preliminary test, a period of approximately two weeks will be allowed for upgrades or changes. After that time, no further upgrades or changes (other than repair of damaged or failed components) will be permitted.
3. A final series of tests will be conducted to fully evaluate the capabilities of the candidate components and/or systems. Any equipment failures will be monitored and reported as such. It should be emphasized that no alteration or adjustments will be permitted during this final test series.

If results of this preliminary testing are promising, more extensive testing at three sites around the U.S. may subsequently be conducted. This second phase will encompass testing at sites with different climatic, train operations, train consist, and rail characteristics. All sites selected will have significant rail and highway traffic volumes so that each detection system experiences a large number of event recordings.

6.2 Data Analysis

Data analysis will include comparisons of results for train presence detection components and/or systems against a baseline of current industry practice using track circuits and also against the other components and/or systems tested. Due to the lack of standard highway vehicle presence detection components and/or systems at HRIs components and systems will only be analyzed against other systems being tested.

6.2.1 Train presence detection option:

A state-of-the-art industry track circuit detection system that is in good functioning order will be used as the baseline for this experiment on train presence detection. The data collected from each candidate train detection components and/or system will be compared to this baseline. The analysis will compare the candidate systems to the baseline system for several specific performance parameters listed in section 2.4 to include:

- Total time the approach and/or island relay is activated,
- Failure to detect a train entering the approach and/or HRI,
- Failure to release after train leaves the approach and/or HRI,
- Premature release or release before the train exits the approach and/or HRI,
- False release (Loss of detection during approach and/or HRI occupancy), and
- Late detection of the train entering the approach and/or HRI.
- Sensitivity to train speed and direction
- Sensitivity to changes in train speed – acceleration and deceleration
- Late release after train departure (> 2 seconds)

6.2.2 Highway vehicle presence detection option:

There are no current industry standard highway detection systems for HRI to be used as the baseline for this experiment on highway vehicle presence detection. The data collected from each candidate highway detection component and/or system will be compared against the other candidate systems tested. The analysis will compare the candidate components and/or systems in several categories including:

- Sensitivity to vehicle location
- Ability to detect vehicles when tires are not within the HRI, but with overhanging body or load
- Release of signal advising of blockage if vehicle departs

Further, a log will be maintained of all activities related to each system including system problems, conformance to evaluation criteria regarding train approach detection and provision of constant warning times, highway vehicle and HRI obstacle detection, human interventions required, maintenance activities, software changes, etc. This log will be used to evaluate the field readiness of each system.

Candidate train detection components and/or systems are expected to be at least as reliable as the current industry standard track circuit detection systems. All failures will be reviewed by the C²AT.

7.0 SCHEDULE

Responses are due by March 22, 1999

Selection of prototypes for further consideration will be made by April 30, 1999

TTC Tests will be completed in the summer of 1999.

Operational field test site testing will be determined pending results of TTCI screening tests and budget allocations.

8.0 TTCI CONTACT

Responses to this RFI and any questions about this project should be directed to:

Mr. Richard Reiff
Principal Investigator
TTCI
P.O. Box 11130
Pueblo, CO 81001
Phone: 719-584-0581, FAX 719-584-0791

9.0 REFERENCES

1. Moody, H., R. Reiff, and S. Gage, "Interim Report: Influence of Contact Patch Resistance on Loss of Shunt," August 1993.
2. Methods of Improving DC Track Circuit Shunting Sensitivity Report D21.3001, GRS, September 1937.
3. Appendix H, "The Rail-Wheel Interface" Proceedings of the C&S Division of the AAR, 1992.
4. "Elements of Railway Signaling," General Railway Signal, June 1979.
5. American Railway Engineering Association, Manual for Railway Engineering, 1994.
6. Association of American Railroads, Communications and Signal Division, Signal Manual, 1993.
7. Association of American Railroads, Advanced Train Control System Specification 110, "Environmental Requirements," Revision 3.0, March 1993.
8. Reiff, R., Gurule, S. and Gage, S., "Final Report, Phase 2, FRA Task Order 106, Alternative Detection Systems", May 1996.
9. Guins, T., Reiff, R. And Gage, S., "Results of Alternative Train Presence Detection Systems Tests," Association of American Railroads, TD96-14, June 1996

APPENDIX A

A.0 BACKGROUND

A.1 Grade Crossing Signal Operation

The basic operation of a conventional DC track circuit provides for train presence detection when a train occupies the circuit. The train "shunts" or shorts out the circuit through the vehicle wheels and axles, de-energizing a track relay, which activates the signal or other control device. These circuits are low voltage devices - generally in the 2 volt range. This is required because the resistance of an alternative current path, the tie/ballast structure, is low -- on the order of two ohms per thousand feet. Normally, the wheel/axle/wheel resistance path is very low - on the order of 20 micro-ohms, making it well suited to shunt the circuit.

The signal-controlling track relay is normally energized to provide an indication of an unoccupied track. This provides the "fail-safe" feature of track circuits. If, for some reason, the circuit is interrupted or the power source fails, the relay "drops out," which causes the signal light or warning device to go to its most restrictive mode. A typical track circuit relay picks up (energizes) at 100 milliamperes and drops out at 50 milliamperes. A minimum "shunt" resistance of 60 milliohms must be detected as specified by FRA regulation.

The same principle applies to the grade crossing island circuit, except these circuits can be audio-frequency "overlay" track circuits instead of DC track circuits. This allows the circuit to be used on top of DC track circuits. Higher frequency AC signals attenuate rapidly in rail, eliminating the requirement for insulated joints at the boundaries of the circuit. These circuits are about 110 to 120 feet long, and overlap the highway crossing. The function of the island circuit is to keep the warning device(s), i.e. gates and flashers, active until the last car of the train leaves the island circuit. This allows for a very rapid deactivation.

Highway crossing warning systems also have an approach circuit. The long approach circuit, when shunted, activates the flashers and gates to provide suitable (a minimum of 20 seconds) warning of an approaching train in either direction. Once the train is in the island circuit, the island circuit controls the gates and flashers.

The performance of track circuits is dependent upon maintaining the circuit to prevent "wrong side" failures from occurring while also minimizing "right side" failures. A "wrong side" failure occurs when the track circuit is occupied but the control relay is energized, i.e., the warning system is not activated. This is opposed to a "right side" or fail-safe failure wherein the warning system is activated when no train is in the circuit. (See Appendix B for a discussion of fail-safe design concepts as applied to railroad signal systems.)

A.2 Loss of Shunt

Since track circuits operate at low voltages and currents, the effect of highly resistive thin films on wheels and the rail can affect their performance. As the film resistance increases, the likelihood of a loss of shunt increases. Thus, shunting sensitivity is dependent upon the ballast resistance, the rail and wheel surface condition (i.e., film resistance, wheel/axle/wheel resistance and contact pressure). Several European, North American and Japanese studies are referenced in the "Interim Report: Influence of Contact Patch Resistance on Loss of Shunt." These studies have identified the principal cause of the loss of shunt as films on the wheel and rail, which exhibit the characteristics of a semi-conductor.

These films are usually composed of various oxides of iron, rust or magnetite (black iron oxide), sand, and small traces of other oxides and carbon. Other external materials such as leaves or lading are implicated in specific cases. Some laboratory tests have implicated films built up from brake shoe materials. At first, lubrication was thought to have contributed to the film make-up, but recent tests (see A.2.1) indicate that lubrication need not be present to have highly resistive films on the rail. However, there may be specific isolated cases where lubrication contributes to film resistance.

The wheel/axle/wheel resistance is negligible. Thus, within the limitations of the track circuit, the film resistance and how that resistance varies with contact pressure become the physical limiting factors for good shunting. This relationship has been known for years, and has resulted in not relying on track shunt for light axle load maintenance-of-way equipment.

The semi-conductor characteristics of these highly resistive films require the film to be "perforated" to allow appreciable current to flow.

An AAR Communications and Signal Division report of data taken from an Organization de Recherche d'Essais (ORE, now European Rail Research Institute) series of reports published in 1963 concluded:

1. The perforating voltage of the shunt path is the sum total of the perforating voltages occurring at each wheel/rail interface.
2. The perforating voltage of the wheel/rail interface depends inversely on the contact pressure.
3. The perforating voltage depends on the relative humidity of the air. In the ORE tests, the perforation voltage using a 50 Hz sinusoidal current was cut in half in damp weather as opposed to dry weather.
4. When a wheel is moving, electrical contact between the rail and wheel is continually being created and destroyed.

The effect of humidity on the circuit performance may be countered by the overall circuit performance in wet versus dry conditions. As the ballast resistance goes up in dry conditions, the current in the track circuit goes up, potentially improving the shunting performance of the circuit. The effect of humidity may be an artifact of the circuit design, not any fundamental change in the perforating voltage requirements.

A.2.1 Findings to Date

A measurement program begun by the Association of American Railroads and the Federal Railroad Administration in 1992 and completed in December 1993 included a major data collection program with audio-frequency island circuits at several revenue service sites where loss of shunt was known to have occurred and at AAR's Transportation Test Center. Auxiliary sites were established at some of these revenue service sites. These auxiliary island circuits were set up adjacent to the island circuit at the grade crossing; with all the functionality of an island circuit except they did not control any gates or flashers. These auxiliary circuits were placed within 100 ft. of the functioning island circuit. The purpose was to enable train-by-train comparisons of the responses of the two adjacent circuits.

Each field site was equipped with a data collection system. The data system recorded the output or receiver voltage and the status of the "island drive relay." The island drive relay controls the active warning devices, i.e., the gates and flashers. Severe loss of shunt resulted in the activation or "pick up" of the island drive relay, resulting in a momentary deactivation of the warning system.

Please refer to the "Interim Report: Investigation of Contact Patch Resistance on Loss of Shunt" for a detailed evaluation of the data collection.

A.2.1.1 Results

Results of the field tests showed some shunt loss at each of the field sites. A few of these events caused the island drive relay to pick up, indicating a possible deactivation of the warning device. Of 42,048 trains measured over the sites, 127 or .30% had an occurrence of island drive relay pick up. The number of occurrences and their duration varied considerably from site to site, suggesting that site specific conditions exist, either physically or electrically. Because loss of shunt was known to have previously occurred at these sites, these data are not necessarily representative of all in-service sites.

An analysis of the longest duration event in each of the 127 occurrences of island drive relay pick up was conducted. Approximately 72% of all occurrences were less than one second in duration, with the maximum duration event of 17 seconds.

Since the total shunt resistance includes the resistance of the wheel/axle/wheel resistance, wheel/axle/wheel resistance data were taken on 140 wheel samples. The wheel/wheel resistance data indicated that the actual resistance is at most 20 micro-ohms, negligible for this analysis.

A.2.1.2 Wheel and Rail Resistive Films

Rail samples and film samples were removed from the field sites for film analysis. The result of laboratory measurements showed that:

1. There was a presence of a highly resistive film on the rail surface, but no film at the "normal" contact patch in the center of the rail.
2. Material in the resistive films was sand and iron oxides. Small traces of other oxides and carbon were detected. There was little variation in the material makeup from site to site. There was variation in the thickness and location of the films on the railhead.

These data suggest that the film on the railhead varies in extent and thickness across the railhead, and that wheels running off the normal contact patch may be more likely to cause loss of shunt. Also, the materials in the film are ordinary products: rust, magnetite (a normal byproduct of the contact between wheels and rails), and sand either from external sources or used to provide tractive effort. Sanders are required by Federal regulation on all locomotives.

A laboratory test was conducted to examine the relationship of axle load to film resistance. This test showed an inverse relationship between electrical resistance and load. This relationship could be expected as well in the field. The relationship appears to be log linear and monotonic.

APPENDIX B: EXPLANATION OF FAIL-SAFE DESIGN CONCEPTS

This appendix explains some of the major design concepts of safety circuits in "laymen's terms". The intent is to help those outside the signal industry understand the philosophy behind signal design.

FAILSAFE DESIGN, RELIABILITY, AND PROBABILITY

The theory behind failsafe design is to create systems and equipment in such a way that all possible failures will cause the system to be placed in its safest or most restrictive state. In the case of crossing warning systems, for example, if anything happens that would prevent the equipment from detecting an approaching train, the warning system should be activated to alert the public that the detection devices are not properly functioning. While it is recognized that in an imperfect world, nothing can be made totally failsafe, the concept of acceptance of any probability of a failure that could cause the warning devices to remain inactive (a "wrong side failure") and possibly allow the unsuspecting public to drive into the path of an approaching train has never been accepted. Every wrong side failure is investigated thoroughly. No matter how unlikely the probability of a second occurrence, if any design changes to the system or any component of the system can be made to prevent another occurrence, they will be. This policy has been in operation for over a century. Through it has evolved the remarkably safe equipment we use today.

Reliability of equipment is often mistaken for failsafe. If high quality devices with low probability of failure are used, it is assumed that the chance of a wrong side failure is very slim. It is accepted that reliability of equipment is important. A warning device that is often active even when there is no danger will, like the boy that cried "wolf" too many times, eventually be ignored. There is a constant battle to design a system that is as failsafe as possible without sacrificing reliability. Most of the sophisticated equipment in use today is constantly self-checking all of its components. If any single part is not functioning properly, the crossing will activate. In such a system, the reliability of proper operation is dependant on all of its parts.

In some systems, a "redundant" or backup warning device is designed to take over if the primary device fails any of its self-check tests. While this is done to increase the reliability of the crossing, it has nothing to do with its failsafe operation. The backup device will contain the same self-checking circuits as the primary device. If it also fails to work as intended, the warning system will be activated.

In spite of the use of high quality components, redundant equipment, extensive quality checks and periodic testing in the field, there are still many occurrences of crossing warning devices being falsely activated. The environment in which the equipment operates is very rugged. Lightning, water, vandals, and even vermin will sometimes cause problems. Most of all, though, there are thousands of crossings with warning systems. The more devices there are, of course, the greater the possibility that one or more of them will detect a problem and activate the warning system even though a train isn't approaching. Probably everyone has seen a crossing system operate when it shouldn't. However, very few have seen a crossing warning system not operate when it should. If only reliability and not fail-safety was a concern when the equipment was designed, probability would dictate that many of the false activations of warning devices that presently occur would be "wrong side" failures that would cause the equipment to not operate when it should. The resulting danger to the public would be intolerable.

As an example of non-failsafe signal design principles, assume that we need to provide a very simple crossing warning device. First, we take a section of track that is long enough to provide plenty of warning when the wheels of a train enter it and use insulated joints to electrically isolate it from the rest of the track (see Figure 1). Then, we take a battery and connect one terminal of it to one of the rails. Now, take a wire from the other rail and connect it to one side of the coil of a relay. Finally, we run a wire from the other side of the relay coil back to the other terminal of the battery. If an approaching train passes the insulated joints and runs onto our track circuit, its axles will short between the rails forming a path for the electricity to flow from one terminal of the battery to one rail, through the axles of the train to the other rail. It will then flow through the coil of the relay to the other terminal of the battery and energize the relay (see Figure 2). If the warning system is turned on by the contacts of the relay when it is energized, then the warning will occur whenever a train is coming near the crossing... Unless, of course, the battery goes dead, or one of the wires break, or a terminal or connection becomes loose or corrodes, or a rail breaks close to the crossing, or the relay coil burns out. If any of these things occur, then the warning will not be activated, and the flashing lights will remain dark as the train speeds across the highway.

Of course, we can do our best to "armor plate" the system to make it as reliable and safe as possible. We could use high quality and high capacity batteries with equally good battery chargers. We could use the best terminals and

connections and cable and relays that money can buy. We could do all these things, but there would still be some risk.

Probability is accumulative. If the relay works properly 99.9999% of the time (fails after one-million operations), and there is equal reliability in the cable, battery and connections, the probability of the crossing failing is 0.0001% for the battery, plus 0.0001% for each of 6 connections, plus 0.0001% for each of three wires, plus 0.0001% for each rail. The total probability of a wrong side failure is 0.0012%, or about 1 failure every 83,000 operations. If we assume 10 trains a day, the probability is one failure every 8,300 days or every 23 years. This is an extremely reliable crossing. If we add the fact that due to the overlapping of many crossing approaches, timing circuits, cutout circuits to prevent the crossing warning system from continuing to operate as a train goes away from the crossing (tail-ring), as well as many other features that are needed at modern crossings, the 12 components of our simple warning circuit increases to dozens or even hundreds of separate components. This fact causes the probability of a wrong side failure to increase dramatically.

Obviously, merely using very reliable components will not make our crossing safe. To meet failsafe principles, a design change must be made. First, take the battery and connect one terminal to the end of one rail near the insulated joints, and connect the other terminal through a resistor to the other rail at the same end of the track section (see Figure 3). Now, go to the other end of the track section and connect a wire from one rail to one side of the relay coil. Finally, connect the other side of the relay coil to the other rail. Now, the current will flow from one terminal of the battery through the resistor to one rail. It then travels down the rail to the wire that is connected to the relay. It passes through the relay and back through the other rail and finally to the other terminal of the battery. The relay is now energized using the rails as if they are two wires. When a train comes into the track section, the wheels will short between the rails, as in Figure 3. (The resistor in the wire from the battery to the rail is to prevent the battery from being damaged when the rails are shorted by the train.) The energy to the relay will be cut off due to the short circuit caused by the train. If the contacts of the relay are wired opposite to the previous example then the crossing warning system will be activated when the relay is shorted out by the train.

This circuit is designed according to fail-safe principles. If the battery goes dead, if a rail breaks, if any connections are loose or a wire is broken or cut, the relay will be turned off thereby activating the crossing warning devices. Now, the reliability of the components become an issue of reduced false activation of the warning system rather than probability that no warning will occur when it is needed.

While the above example of the "closed-loop" principle used in design of signal systems is very simplified, it shows the basic concept that is used in even the most complex, high-tech devices. All modern railroad warning systems are based on activation by absence of an expected electric voltage or signal. This way, if anything fails to perform correctly, the warning system will activate.

When electronic circuits are used that contain transistors and integrated circuits, the failsafe concept becomes a little more difficult. A transistor is basically like a relay. A small voltage applied to its base will cause it to conduct like a switch. The problem is, the failure mode of a transistor is not as predictable as a relay. The relay contacts will almost always close if it fails, especially if it is designed according to proper Association of American Railroads recommended practices. A transistor, however, can fail in either a conducting or non-conducting mode. Most signal equipment checks the transistors by constantly turning them on and off. If the output of the equipment stays constantly on or constantly off due to a failed transistor or any other component, then the crossing warning system is activated. Here, again, the absence of an expected signal is used to turn on the warning system.

Microprocessors, too, are checked in a similar manner. Whether two processors are constantly checking each other, or some external circuit is used to check the processor, absence of an expected pulse at the proper output at the proper time will cause the warning to be activated.

Once it is understood, the failsafe design concept is really not very difficult. Its foundation lies in doing everything possible to make sure that if any part of a circuit fails, it will activate the warning system rather than allow the possibility of no warning being given. Because railroad signal design follows failsafe design concepts, the occurrence of a wrong side failure is extremely rare even though millions of crossing operations occur every day.

(blank)

**APPENDIX C:
TEST MATRICES FOR RAIL OPERATIONS AND
HIGHWAY VEHICLE OPERATIONS**

MATRIX 1 - TRAIN MOVES
BASELINE - THRU PASSES

Run #	Direction	Speed (mph)	Notes
101	CCW	5	
102	CW	5	Backing consist
103	CCW	5	
104	CW	5	Backing consist
105	CCW	10	
106	CW	10	Backing consist
107	CCW	10	
108	CW	10	Backing consist
109	CCW	20	
110	CW	20	Backing consist
111	CCW	35	
112	CW	35	Backing consist
113	CCW	50	Keep running around loop
114	CCW	50	
115	CCW	65	Reduce number of cars to maintain speed.
116	CCW	65	
117	CCW	80	Reduce number of cars to maintain speed
118	CCW	80	
119	CCW	80	System 4 shut off
120	CW	100*	Forward
121	CW	100*	
122	CW	100*	System 1 on alone
123	CW	60	System 1 on alone
124	CCW	120*	ACELA train set
125	CCW	120*	ACELA train set

* Operated on RTT, all other runs on TTT

MATRIX 2 - TRAIN MOVES

VARIABLE SPEEDS*

Run #	Direction	Speed (mph)	Notes
201	CW	30-5	Approach at 30 slow to 5 and maintain
202	CW	40-5	Approach at 30 slow to 5 and maintain
203	CCW	5-Accel	Approach at 5 – max acceleration
204	CCW	5-Accel	Approach at 5 – max acceleration

*Speed changes initiated after test system indicated train approach

MATRIX 3 – TRAIN MOVES SWITCHING MOVES

Run #	Direction**	Speed (mph)	Notes
301	CCW		Slow run, stop spine car over island for 5-10 minutes, then continue in same direction
302	CW		Repeat 301
303	CCW		Slow run, stop consist with wheel of rail car directly over island entrance for 5-10 minutes, then continue in same direction
304	CW		Repeat 303
305	CCW		Slow run into island with at least 3 cars, stop. Uncouple last car, depart island. Leave lone car standing for 5-10 minutes, back onto car, couple and depart in original direction
306	CW		Repeat 305
307	CCW		Back locomotive and 6 cars through island, stop for 3 minutes, pull forward 2 car lengths, and stop 2 minutes, back through island.
308	CW		Repeat 307
309	CCW		Reverse 3 cars across island, stop, forward through island in same direction
310	CW		Repeat 309
311	CCW		Kick single car through island. After car has departed island follow with locomotive to capture.
312	CW		Repeat 310
310	CCW		Repeat 311

**Indicated initial train direction for switching moves

**MATRIX 4 – TRAIN MOVES
MULTIPLE TRAINS**

Run #	Direction RTT	Speed (mph) RTT	Direction TTT	Speed (mph) TTT	Notes
400	CW	> 60	CW	> 60	Adjacent/similar train speeds
401	CW	> 60	CW	< 30	Slow speed first approach
402	CW	> 60	CW	30-0	Stop slow train at crossing, high speed pass, then depart
403	CW	> 60	CCW	> 60	Opposing direction with similar approach time
404	CW	> 60	CCW	< 30	Slow speed first approach
405	CCW	>40	CCW	40-0	Train on TTT stop on island, proceed after train on RTT clears island
406	CCW	>40	CW	40-0	Train on TTT stop on island, proceed after train on RTT clears island

**MATRIX 8
HI-RAIL VEHICLES**

Run #	Vehicle	Speed (mph)	Notes
801	Hi-rail	10	Run hi-rail through HRI zone on rails
802	Hi-rail		Enter HRI zone on roadway, depart on rails
803	Hi-rail		Run hi-rail into HRI on rails, depart on roadway

**APPENDIX D:
HIGHWAY VEHICLE DETECTION TEST MATRIX**

Table D1. Vehicle ID Codes Used in Tests

Vehicle ID No.	Vehicle Type
1	Pedestrian
2	Pedestrian w/bicycle
3	Auto/Small pickup
4	Large pickup
6	Stake bed (8-ton flat bed)
7	Large Box Truck
8	Pickup w/trailer
9	Stake bed w/overhanging load

**MATRIX 5 – HIGHWAY VEHICLES
STATIC DETECTION**

Run #	Vehicle	Notes
501 –501K	1-6	Detection at foul point. Each vehicle will slowly enter HRI limits until detection is made.
509-516	1-6	Vehicles stopped over track centerline.

**MATRIX 6 – HIGHWAY VEHICLES
DYNAMIC DETECTION**

Run #	Vehicle	Speed (mph)	Notes
601-608	1-6	5	Vehicles at constant speed through HRI. Approaching from East
601A-608A	1-6	5	Vehicles at constant speed through HRI. Approaching from West
609-611	3,4,5	5-0-5	Vehicle enters HRI, stops, continues through. Approaching from East
609A-611A	3,4,5	5-0-5	Vehicle enters HRI, stops, continues through. Approaching from West
617-619	3,4,5	5-0-5	Vehicle enters HRI, reverses out. Approaching from East
617A-619A	3,4,5	5-0-5	Vehicle enters HRI, reverses out. Approaching from West
623-625	3	5	Vehicle enters HRI and performs “evasive” maneuver (zigzag)
629-631	3,4,5	20	Vehicles at constant speed through HRI
629A-631A	3,4,5	20	Vehicles at constant speed through HRI
635-636	3	10	Vehicles crossing HRI from opposing directions
637-638	3	10	Vehicles passing in same direction while crossing HRI
639-640	3	5	One vehicle enters HRI and stops. Second vehicle passes through HRI.
641-642	3		One vehicle enters HRI and stops. Second vehicle enters HRI and pushes first vehicle through HRI.
643-644	8		Pickup/trailer enter HRI and stops. Un-hitch trailer. Pickup departs HRI

**MATRIX 7 – HIGHWAY VEHICLES
OBSTACLE DETECTION**

Run #	Vehicle	Speed (mph)	Notes
701	6	5	Drop empty appliance box in HRI. Approach from East
701A	6	5	Drop empty appliance box in HRI. Approach from West
703	9	0	Stop vehicle outside of HRI with rail section overhanging within HRI. Approach from East
704	9	0	Stop vehicle outside of HRI with rail section overhanging within HRI. Approach from West

(blank)

**APPENDIX E:
TEST RESULTS TABLES 1-6**

Table numbering code: x.n

x refers to system number 1-6

n refers to test matrix number (appendix C, D)

Notes for table abbreviations and headers:

Base approach: Indicates time in seconds between data collection system being armed and actual island arrival.

Based island time: Actual time in seconds of train occupying the 120 foot island limit

TTT/RTT approach scds: Time in seconds that the test system indicated between approach limit detector and arrival at the island. A time greater than the “base approach” time indicates the system was armed before arriving at the approach limit (activation in advance of the sensor).

Island Delta: Difference in seconds between the actual (base) island occupancy time and the test system island occupancy time. A negative (-) indicates the test system released early, while positive numbers indicated the island “hung” and release was after the train departed.

C – indicates Critical failure, refer to report tables 3 and 4

N – indicates Nuisance failure, refer to report tables 3 and 4

M – indicates missed detection, refer to report tables 3 and 4

Table 1.1

MATRIX 1

Run #	Speed MPH	TTT	TTT	RTT	RTT	Base	Base	Island	Notes
		App Scds.	Island Scds.	App Scds.	Island Scds.	App Scds.	Island Scds.	Delta Scds.	
101	5	268	108.5		11	780	109	-0.5	
102	5	612	111		10	821	112.5	-1.5	
103	5	208.5	108		11	784	104	4	
104	5	737.5	179.5		14	750	102	77.5	
105	10	64	55.5		8	415	56	-0.5	
106	10	376.5	54		9.5	382	51.5	2.5	
107	10	401	56		10.5	395	56.5	-0.5	
108	10	379.5	77		11	383	51.5	25.5	
109	20	207	30		6.5	210	30	0	
110	20	195.5	42		6.5	197	25	17	
111	35	119	34		5.5	118	17.5	16.5	
112	35	118.5	30.5		3.5	119	18	12.5	
113	50	90.5	34.5		4.5	91	13	21.5	
114	50	13.5	13		4	88.5	13	0	
115	65	35.5	27		2.5	39.5	3.5	23.5	
116	65	44	25		2	35.5	3.5	21.5	
117	80	37.5	36.5		2	31.5	3	33.5	
118	80	37.5	29.5		2.5	35.5	3	26.5	
119	80	37	37		2.5	35.5	3	34	
120	100			62.5	58.5	40.5	1	57.5	
121	100			77.5	73.5	43.5	1	72.5	
122**	100			86.5	82.5	37	1	81.5	System 1 on alone
123**	60			166.5	138	71.5	2	136	System 1 on alone
124	120								Not Active
125	120								Not Active

Table 1.2

MATRIX 2

Run #	Speed MPH	TTT	TTT	RTT	RTT	Base	Base	Island
		App Scds.	Island Scds.	App Scds.	Island Scds.	App Scds.	Island Scds.	Delta Scds.
201	30-5	252	166.5			469	97.5	69
202	30-5	278	194.5			281	90	104.5
203	5-35	520	29.5			532	29.5	0
204	5-35	373	17			375	14	3

**Table 1.3
MATRIX 3**

Run #	Speed MPH	TTT App Scds.	TTT Island Scds.	RTT App Scds.	RTT Island Scds.	Base App Scds.	Base Island Scds.	Island Delta Scds.
301		691	506.5			769	501	5.5
302		647	518			643	493	25
303		881	473			900	480	-7
304		694	477			691	475.5	1.5
305		527	462			1108	461	1
306		722	569.5			720	594	-24.5
307		901	604			900	605	-1
308		576	427.5			573	425	2.5
309		380	127			377	127.5	-0.5
310		329	81.5			409	82	-0.5
311		201	15.5			205	17	-1.5
312		97	29			280	27.5	1.5
313		197	13.5			198	13.5	0
314		139	36.5			461	37.5	-1

**Table 1.4
MATRIX 4**

Run #	Speed MPH	TTT App Scds.	TTT Island Scds.	RTT App Scds.	RTT Island Scds.	Base App Scds.	Base Island Scds.	RTT Base Island Scds.
400	50	65	39.5	180	134.5	75	9.5	3
401	30	74.5	22.5	169	169	141	16.5	6
402		292	199	208	171.5	313	126.5	3
403	50	75	40	207	159.5	188	9.5	4.5
404	30	135	46.5	157	118	150	20.5	3
405		359	276.5	221	250.5	370	189	3

**Table 1.8
MATRIX 8 - HI RAIL VEHICLE**

	Speed MPH	Detect	Comments
801	20	*	On RTT. Hi rail straight through from North - On at Post 100
802	0-20	*	Hi-rail on from road - Departs on rails
803	20-0	*	Hi rail approach on rails - Departs on road

* System not operational during Hi Rail testing

**Table 2.1
MATRIX 1**

Run #	Speed MPH	TTT	TTT	RTT	RTT	Base	Base	Island
		App	Island	App	Island	App	Island	Delta
		Scds.	Scds.	Scds.	Scds.	Scds.	Scds.	Scds.
101	5	337	107.5			780	109	-1.5
102	5	356	110.5			821	112.5	-2
103	5	420	105.5			784	104	1.5
104	5	398	103.5			750	102	1.5
105	10	181.5	54.5			415	56	-1.5
106	10	206.5	52.5			382	51.5	1
107	10	178.5	54.5			395	56.5	-2
108	10	210.5	53			383	51.5	1.5
109	20	92	28.5			210	30	-1.5
110	20	108.5	26.5			197	25	1.5
111	35	52	16			118	17.5	-1.5
112	35	51.5	16			119	18	-2
113	50	39.5	11.5			91	13	-1.5
114	50	38.5	11			88.5	13	-2
115	65	28	2			39.5	3.5	-1.5
116	65	28	1.5			35.5	3.5	-2
117	80	23	1.5			31.5	3	-1.5
118	80	23	1.5			35.5	3	-1.5
119	80	23	1.5			35.5	3	-1.5
120	100			26.5	1.5	40.5	1	0.5
121	100			27	1	43.5	1	0
124	120			20.5	3	3	3	0
125	120			20.8	3	3	3	0

**Table 2.2
MATRIX 2**

Run #	Speed MPH	TTT	TTT	RTT	RTT	Base	Base	Island
		App	Island	App	Island	App	Island	Delta
		Scds.	Scds.	Scds.	Scds.	Scds.	Scds.	Scds.
201	30-5	117.5	95.5			469	97.5	-2
202	30-5	147.5	91			281	90	1
203	5-35	137.5	28			532	29.5	-1.5
204	5-35	125	15.5			375	14	1.5

Table 2.3
MATRIX 3

Run #	Speed MPH	TTT	TTT	RTT	RTT	Base	Base	Island
		App Scds.	Island Scds.	App Scds.	Island Scds.	App Scds.	Island Scds.	Delta Scds.
301		106.5	498.5			769	501	-2.5
302		150.5	494			643	493	1
303		254	475.5			900	480	-4.5
304		188	475.5			691	475.5	0
305		183	461			1108	461	0
306		94	595			720	594	1
307		155	603			900	605	-2
308		104	426			573	425	1
309		154	127			377	127.5	-0.5
310		128	81.5			409	82	-0.5
311		94	14.5			205	17	-2.5
312		87	25			280	27.5	-2.5
313		91	12.5			198	13.5	-1
314		79	35			461	37.5	-2.5

Table 2.4
MATRIX 4

Run #	Speed MPH	TTT	TTT	RTT	RTT	Base	TTT	RTT
		App Scds.	Island Scds.	App Scds.	Island Scds.	App Scds.	Island Scds.	Island Scds.
400	50	42	11	53	2	75	9.5	3
401	30	62	18.5	91	5	141	16.5	6
402		121	128	52	2.5	313	126.5	3
403	50	40	10.5	109	4	188	9.5	4.5
404	30	72	21.5	56	2.5	150	20.5	3
405		125	190	49	2.5	370	189	3

System 2

Table 2.5

MATRIX 5 - STATIC OBSTACLE DETECTION

OBSTACLE MOVED INTO HRI AFTER TRAIN APPROACH INDICATION

Run #	West	West	West	West	West	East	East	East	East	East	Obstacle
	14'	11'	9'	7.5'	5.5'	14'	11'	9'	7.5'	5.5'	
501 - 501A			X				X				PEDESTRIAN
501B - 501C			X					X			PEDESTRIAN W/BICYCLE
501D - 501E			X						X		SMALL TRUCK
501F - 501G				X				X			LARGE PICK-UP W/TRAILER
501H - 501I				X				X			STAKE BED TRUCK
501J - 501K			X							X	MOTORCYCLE

OBSTACLE PLACED IN THE MIDDLE OF THE CROSSING BEFORE TRAIN APPROACH INDICATION WAS GIVEN

- DETECT
- X PEDESTRIAN
- X PEDESTRIAN W/BICYCLE
- X SMALL TRUCK
- X LARGE PICK-UP W/TRAILER
- X STAKE BED TRUCK
- X MOTORCYCLE

System 2

Table 2.6
MATRIX 6 - DYNAMIC OBSTACLE DETECTION

Run #	Detect	Approach	Approach	Speed	Obstacle	COMMENTS
		E to W	W to E			
601 - 601A		X	X	5	SMALL TRUCK	
602 - 602A		X	X	5	LARGE PICK-UP W/TRAILER	
603 - 603A		X	X	5	STAKE BED TRUCK	
604 - 604A		X	X	5	MOTORCYCLE	
605 - 605A		X	X	20	MOTORCYCLE	
609 - 609A		X	X	5-0-5	SMALL TRUCK	
610 - 610A		X	X	5-0-5	LARGE PICK-UP W/TRAILER	
611 - 611A		X	X	5-0-5	STAKE BED TRUCK	
617 - 617A		X	X	5-Rev	SMALL TRUCK	
618 - 618A		X	X	5-Rev	LARGE PICK-UP W/TRAILER	
619 - 619A		X	X	5-Rev	STAKE BED TRUCK	
623	X			5		EVASIVE ACTION
624	X			5		EVASIVE ACTION
625	X			5		EVASIVE ACTION
629 - 629A		X	X	20		
630 - 630A		X	X	20		
631 - 631A		X	X	20		
635	X			5		Vehicles approaching from opposite directions
636	X			5		Vehicles approaching from opposite directions
637	X					Vehicles approach from same direction - pass on crossing
638	X					Vehicles approach from same direction - pass on crossing
639	X					Vehicles approach from same direction - Vehicle 1 stops/Vehicle 2 passes/Vehicle 1 continues
640	X					Vehicles approach from same direction - Vehicle 1 stops/Vehicle 2 passes/Vehicle 1 continues
641	X					Vehicle 1 enter crossing and stop/Vehicle 2 pulls in behind/Vehicles exit together
642	X					Vehicle 1 enter crossing and stop/Vehicle 2 pulls in behind/Vehicles exit together
643	X					Truck/Trailer enter HRI - unhitch trailer - truck departs - truck retrieves trailer
644	X					Truck/Trailer enter HRI - unhitch trailer - truck departs - truck retrieves trailer

Table 2.7
MATRIX 7 - DROPPED LOAD DETECTION

Run #	Detect	Approach		Speed	Obstacle	COMMENTS
		E to W	W to E			
701	X					Stake bed enters HRI - drops load - exits
702	X					Stake bed enters HRI - drops load - exits
703						Pull boom truck through HRI - Stop truck on other side of HRI with 2 rail sections overhanging 15'
704						Pull boom truck through HRI - Stop truck on other side of HRI with 2 rail sections overhanging 15'

Table 2.8
MATRIX 8 - HI RAIL VEHICLE

Run #	Speed	Detect	Comments
	MPH		
801	20	X	On RTT. Hi rail straight through from North - On at Post 100
802	0-20		Hi-rail on from road - Departs on rails
803	20-0	X	Hi rail approach on rails - Departs on road - failed to release

System 3
Systems Innovations - Train Detection System

Table 3.1
MATRIX 1

Run #	Speed	TTT App	TTT Island	RTT App	RTT Island	Base App	Base Island	Island Delta
	MPH	Scds.	Scds.	Scds.	Scds.	Scds.	Scds.	Scds.
101	5	626				780	109	-109
102	5	577				821	112.5	-112.5
103	5	533.5				784	104	-104
104	5	668.5				750	102	-102
105	10	325				415	56	-56
106	10	349.5				382	51.5	-51.5
107	10	0				395	56.5	-56.5
108	10	346.5				383	51.5	-51.5
109	20	107.5				210	30	-30
110	20	162.5				197	25	-25
111	35	0				118	17.5	-17.5
112	35	77				119	18	-18
113	50	103				91	13	-13
114	50	0				88.5	13	-13
115	65	0				39.5	3.5	-3.5
116	65	70				35.5	3.5	-3.5
117	80	45.5				31.5	3	-3
118	80	51				35.5	3	-3
119	80	55.5				35.5	3	-3
120	100			0		40.5	1	-1
121	100			0		43.5	1	-1
124								
125								

Table 3.2
MATRIX 2

Run #	Speed	TTT App	TTT Island	RTT App	RTT Island	Base App	Base Island	Island Delta
	MPH	Scds.	Scds.	Scds.	Scds.	Scds.	Scds.	Scds.
201	30-5	409.5				469	97.5	-97.5
202	30-5	0				281	90	-90
203	5-35	154.5				532	29.5	-29.5
204	5-35	215				375	14	-14

Table 3.3

MATRIX 3

Run #	Speed MPH	TTT App Scds.	TTT Island Scds.	RTT App Scds.	RTT Island Scds.	Base App Scds.	Base Island Scds.	Island Delta Scds.
301		286				769	501	-501
302		709				643	493	-493
303		1037				900	480	-480
304		744				691	475.5	-475.5
305		89				1108	771	-771
306		157				720	594	-594
307		0				900	605	-605
308		579.5				573	425	-425
309		303				377	127.5	-127.5
310		164.5				409	82	-82
311		288				205	17	-17
312		99.5				280	27.5	-27.5
313		163				198	13.5	-13.5
314		161.5				461	37.5	-37.5

Table 3.4
MATRIX 4

Run #	Speed MPH	TTT App Scds.	TTT Island Scds.	RTT App Scds.	RTT Island Scds.	Base App Scds.	Base Island Scds.	Base Island Scds.	TTT Island Delta	RTT Island Delta
400	50	195				75	9.5	3		
401	30	169				141	16.5	6		
402		308				313	126.5	3		
403	50	129.5				188	9.5	4.5		
404	30	233				150	20.5	3		
405		436				370	189	3		

Table 3.8
MATRIX 8 - HI RAIL VEHICLE

Run #	Speed MPH	Detect	Comments
801	20		On RTT. Hi rail straight through from North - On at Post 100
802	0-20		Hi-rail on from road - Departs on rails
803	20-0		Hi rail approach on rails - Departs on road

**System 4
Pintsch Bamag - Train & Vehicle Detection System**

E

MATRIX 1

Run #	Speed MPH	TTT	TTT	RTT	RTT	Base	Base	Island
		App	Island	App	Island	App	Island	Delta
		Scds.	Scds.	Scds.	Scds.	Scds.	Scds.	Scds.
101	5	340	119			780	109	10
102	5	359	122			821	112.5	9.5
103	5	404	117.5			784	104	13.5
104	5	385.5	115.5			750	102	13.5
105	10	182.5	61			415	56	5
106	10	199.5	59.5			382	51.5	8
107	10	180	61.5			395	56.5	5
108	10	202.5	61			383	51.5	9.5
109	20	93.5	33			210	30	3
110	20	106	31			197	25	6
111	35	53.5	19			118	17.5	1.5
112	35	52.5	19.5			119	18	1.5
113	50	40.5	15			91	13	2
114	50	39	11			88.5	13	-2
115	65	29	4			39.5	3.5	0.5
116	65	29	4			35.5	3.5	0.5
117	80	23.5	4			31.5	3	1
118	80	24	3.5			35.5	3	0.5
119	80	NOT	ACTIVE			35.5	3	-3
120	100			28.5	3	40.5	1	2
121	100			29	2.5	43.5	1	1.5
124	120			20.3	3	3	3	0
125	120			20.5	3	3	3	0

Table 4.2

MATRIX 2

Run #	Speed MPH	TTT	TTT	RTT	RTT	Base	Base	Island
		App	Island	App	Island	App	Island	Delta
		Scds.	Scds.	Scds.	Scds.	Scds.	Scds.	Scds.
201	30-5	131	106			469	97.5	8.5
202	30-5	160	100.5			281	90	10.5
203	5-35	132	32.5			532	29.5	3
204	5-35	100	18			375	14	4

Table 4.3

MATRIX 3

		TTT	TTT	RTT	RTT	Base	Base	Island
Run #	Speed	App	Island	App	Island	App	Island	Delta
	MPH	Scds.	Scds.	Scds.	Scds.	Scds.	Scds.	Scds.
301		111	505			769	501	4
302		163.5	499.5			643	493	6.5
303		682	525			900	480	45
304		627	479			691	475.5	3.5
305		215	216			1108	461	-245
306		99.5	602			720	594	8
307		162	612.5			900	605	7.5
308		113	432.5			573	425	7.5
309		165	142.5			377	127.5	15
310		137	155.5			409	82	73.5
311		96	12			205	17	-5
312		90.5	13			280	27.5	-14.5
313		93	11.5			198	13.5	-2
314		0	0			461	37.5	-37.5

Table 4.4

MATRIX 4

		TTT	TTT	RTT	RTT	Base	TTT	RTT
Run #	Speed	App	Island	App	Island	App	Island	Island
	MPH	Scds.	Scds.	Scds.	Scds.	Scds.	Scds.	Scds.
400	50	41	14	56	4	75	9.5	3
401	30	60	21.5	96	6.5	141	16.5	6
402		130	133.5	55	4	313	126.5	3
403	50	39	13	112	5.5	188	9.5	4.5
404	30	70	25.5	59	4	150	20.5	3
405		138	195	51	3.5	370	189	3

**System 4
Pintsch Bamag - Train & Vehicle Detection System**

Table 4.5

MATRIX 5 - STATIC OBSTACLE DETECTION

OBSTACLE MOVED INTO HRI AFTER TRAIN APPROACH INDICATION

Run #	West	West	West	West	West	East	East	East	East	East	Obstacle
	14'	11'	9'	7.5'	5.5'	14'	11'	9'	7.5'	5.5'	
501 - 501A			X						X		PEDESTRIAN
501B - 501C				X			X				PEDESTRIAN W/BICYCLE
501D - 501E			X					X			SMALL TRUCK
501F - 501G			X				X				LARGE PICK-UP W/TRAILER
501H - 501I	X					X					STAKE BED TRUCK
501J - 501K											MOTORCYCLE

OBSTACLE PLACED IN THE MIDDLE OF THE CROSSING BEFORE TRAIN APPROACH INDICATION WAS GIVEN

DETECT	
X	PEDESTRIAN
X	PEDESTRIAN W/BICYCLE
X	SMALL TRUCK
X	LARGE PICK-UP W/TRAILER
X	STAKE BED TRUCK
**	MOTORCYCLE

** System failure prior to testing motorcycle

Table 4.8

MATRIX 8 - HI RAIL VEHICLE

	Speed	Detect	Comments
	MPH		
801	20	X	On RTT. Hi rail straight through from North - On at Post 100
802	0-20		Hi-rail on from road - Departs on rails
803	20-0		Hi rail approach on rails - Departs on road - Failed to release

System 5
PrimeTech - Train & Vehicle Detection System

MATRIX 1

Run #	Speed	TTT App	TTT Island	RTT App	RTT Island	Base App	Base Island	Island Delta
101								
102								
103								
104								
105								
106								
107								
108								
109								
110								
111								
112								
113								
114								
115								
116								
117								
118								
119								
120								
121								
122								
123								

MATRIX 2

Run #	Speed	TTT App	TTT Island	RTT App	RTT Island	Base App	Base Island	Island Delta
						469	304.5	
201	30-5					281	90	
202	30-5					532	29.5	
203	5-35					375	14	
204	5-35							

System 6

ASIM - Vehicle Detection System

Table 6.1

MATRIX 1

Run #	Speed MPH	TTT App Scds.	TTT Island Scds.	RTT App Scds.	RTT Island Scds.	Base App Scds.	Base Island Scds.	Island Delta Scds.
101	5		107			780	109	-2
102	5		106.5			821	112.5	-6
103	5		105			784	104	1
104	5		91			750	102	-11
105	10		56.5			415	56	0.5
106	10		43.5			382	51.5	-8
107	10		65.5			395	56.5	9
108	10		48			383	51.5	-3.5
109	20		104.5			210	30	74.5
110	20		40			197	25	15
111	35		68.5			118	17.5	51
112	35		69			119	18	51
113	50		36.5			91	13	23.5
114	50		43			88.5	13	30
115	65		27			39.5	3.5	23.5
116	65		31			35.5	3.5	27.5
117	80		19.5			31.5	3	16.5
118	80		21			35.5	3	18
119	80		24			35.5	3	21
120	100		0.5			40.5	1	-1
121	100		0			43.5	1	-1
124								
125								

Table 6.2

MATRIX 2

Run #	Speed MPH	TTT App Scds.	TTT Island Scds.	RTT App Scds.	RTT Island Scds.	Base App Scds.	Base Island Scds.	Island Delta Scds.
201	30-5		93			469	97.5	-4.5
202	30-5		88			281	90	-2
203	5-35		25			532	29.5	-4.5
204	5-35		17			375	14	3

Table 6.3
MATRIX 3

Run #	Speed MPH	TTT App Scds.	TTT Island Scds.	RTT App Scds.	RTT Island Scds.	Base App Scds.	Base Island Scds.	Island Delta Scds.
301			502			769	501	1
302			489.5			643	493	-3.5
303			51.5			900	480	-428.5
304			56			691	475.5	-419.5
305			451.5			1108	771	-319.5
306			609.5			720	594	15.5
307			589.5			900	605	-15.5
308			424			573	425	-1
309			122.5			377	127.5	-5
310			84			409	82	2
311			14.5			205	17	-2.5
312			42			280	27.5	14.5
313			38.5			198	13.5	25
314			64.5			461	37.5	27

Table 6.4
MATRIX 4

Run #	Speed	TTT App	TTT Island	RTT App	RTT Island	Base App	TTT Base Island	RTT Base Island
400	50		22.5			75	9.5	3
401	30		22			141	16.5	6
402			114			313	126.5	3
403	50		23			188	9.5	4.5

**System 6
ASIM - Vehicle Detection System**

Table 6.5

**MATRIX 5 - STATIC OBSTACLE DETECTION
OBSTACLE MOVED INTO HRI AFTER TRAIN APPROACH INDICATION**

Run #	West 14'	West 11'	West 9'	West 7.5'	West 5.5'	East 14'	East 11'	East 9'	East 7.5'	East 5.5'	Obstacle
501 - 501A			X						X		PEDESTRIAN
501B - 501C			X						X		PEDESTRIAN W/BICYCLE
501D - 501E				X				X			SMALL TRUCK
501F - 501G			X						X		LARGE PICK-UP W/TRAILER
501H - 501L				X					X		STAKE BED TRUCK
501J - 501K			X							X	MOTORCYCLE

**OBSTACLE PLACED IN THE MIDDLE OF THE CROSSING BEFORE TRAIN
APPROACH INDICATION WAS GIVEN**

DETECT	
X	PEDESTRIAN
X	PEDESTRIAN W/BICYCLE
X	SMALL TRUCK
X	LARGE PICK-UP W/TRAILER
X	STAKE BED TRUCK
X	MOTORCYCLE

System 6 - ASIM - Vehicle Detection System

Table 6.6

MATRIX 6 - DYNAMIC OBSTACLE DETECTION

Run #	Detect	Approach		Speed	Obstacle	COMMENTS
		E to W	W to E			
601 - 601A		X	X	5	SMALL TRUCK	Long count 601
602 - 602A		X	X	5	LARGE PICK-UP W/TRAILER	Long count 602
603 - 603A		X	X	5	STAKE BED TRUCK	Long count 603
604 - 604A		X	X	5	MOTORCYCLE	
605 - 605A		X	X	20	MOTORCYCLE	
609 - 609A		X	X	5-0-5	SMALL TRUCK	
610 - 610A		X	X	5-0-5	LARGE PICK-UP W/TRAILER	
611 - 611A		X	X	5-0-5	STAKE BED TRUCK	
617 - 617A		X	X	5-Rev	SMALL TRUCK	
618 - 618A		X	X	5-Rev	LARGE PICK-UP W/TRAILER	
619 - 619A		X	X	5-Rev	STAKE BED TRUCK	
623	X			5		EVASIVE ACTION
624	X			5		EVASIVE ACTION
625	X			5		EVASIVE ACTION
629 - 629A		X	X	20		
630 - 630A		X	X	20		
631 - 631A		X	X	20		
635	X			5		Vehicles approaching from opposite directions
636	X			5		Vehicles approaching from opposite directions
637	X					Vehicles approach from same direction - pass on crossing
638	X					Vehicles approach from same direction - pass on crossing
639	X					Vehicles approach from same direction - Vehicle 1 stops/Vehicle 2 passes/Vehicle 1 continues
640	X					Vehicles approach from same direction - Vehicle 1 stops/Vehicle 2 passes/Vehicle 1 continues
641	X					Vehicle 1 enter crossing and stop/Vehicle 2 pulls in behind/Vehicles exit together
642	X					Vehicle 1 enter crossing and stop/Vehicle 2 pulls in behind/Vehicles exit together
643	X					Truck/Trailer enter HRI - unhitch trailer - truck departs - truck retrieves trailer
644	X					Truck/Trailer enter HRI - unhitch trailer - truck departs - truck retrieves trailer

Table 6.7

Run #	Detect	Approach		Speed	Obstacle	COMMENTS
		E to W	W to E			
702	X					Stake bed enters HRI – drops load – exits
703	X					Pull boom truck through HRI – Stop truck on other side of HRI with 2 rail sections overhanging 15'
704	X				System 6 delayed detect	Pull boom truck through HRI – Stop truck on other side of HRI with 2 rail sections overhanging 15'

Table 6.8

MATRIX 8 - HI RAIL VEHICLE

	Speed	Detect	Comments
801	20	X	On RTT. Hi rail straight through from North - On at Post 100
802	0-20	X	Hi-rail on from road - Departs on rails
803	20-0	X	Hi rail approach on rails - Departs on road

**APPENDIX F:
ITS SUMMARY REPORT AND RESULTS**

Supplemental Report — Intelligent Transportation Systems Data

BACKGROUND

Track circuits are the most common method currently used by North American railroads to detect trains and control warning devices at highway/railroad intersections (HRI). The introduction of advanced warning systems, such as four quadrant gates and barriers HRIs may require additional information as to train and highway vehicle status to ensure optimal operation and safety. To address these issues, non-track circuit based technologies have been proposed as an alternative for controlling HRI warning devices. Some alternative technologies offer additional features which allows the detection of highway vehicles located within the HRI limits, which may further enhance crossing safety. These issues were addressed under the Federal Railroad Administration's (FRA) Task Order 123. This evaluation included the assessment of operational and detection reliability of alternative technologies at the FRA's Transportation Technology Center near Pueblo, Colorado. During the selection phase for choosing which systems would be asked to participate in Task Order 123 testing, it was also decided that some of these systems might also be able to supply additional information that would be of value in the Intelligent Transportation Systems (ITS) arena. This additional information may include train direction, speed, length and information on the type of train.

SYSTEM SELECTION

Initially, six systems were selected to be included in the Task Order 123 evaluation. Of these six systems, four had the capability of providing varying amounts of ITS information, however, one of the four systems could not be installed in time to meet the test schedule and was not included in the evaluation. Vendors of the remaining three systems were asked, on a voluntary basis, if they would like to demonstrate additional capabilities of their systems. All three vendors agreed to demonstrate these additional capabilities.

SYSTEM DESCRIPTIONS

System 1

This system uses a combination of magnetic anomaly and vibration detectors in a sensor module. These sensors detect a magnetic field change caused by an approaching train. The vibration detectors in the module detect vibrations caused by nearby moving trains. These sensors operate independently of each other. A total of 12 sensors were required for the TTC installation, six on

each track. Two sensors are placed at each end of the approach limits to detect approach trains and two additional sensors are used at the island, one on each side of the HRI. Information is transmitted from each sensor to the control module located near the HRI via RF transmission. The vendor claimed this system was able to provide train direction, speed and length.

System 2

System 2 was evaluated as an integrated train and vehicle detection system. For train detection this system utilized double wheel sensors. Each sensor housing consists of a pair of resonant circuits designed to detect the approach and departure of trains. This system uses two sensors, one on each rail, at each approach limit to count the axles passing over the sensor and indicate train approach. A sensor on each side of the HRI acts as the island circuit. When the number of axles counted in at the approach matches the number of axles passing over the island in the same direction, the system indicates a clear circuit. Each sensor pair is hardwired to the control circuit located near the HRI. For vehicle detection this system utilized a combination of low power laser and video imaging to detect obstacles at the HRI. The vendor of system 2 claimed the system could provide train direction and speed information.

System 4

System 4 was evaluated as an integrated train and vehicle detection system. For train detection this system utilizes inductive loops placed between the running rails to detect the approach of a train. Two of these inductive loops were placed at each approach limit on the RTT and TTT to detect the approach of a train. A single loop was placed on each side of the HRI on the TTT while two loops were placed on each side of the HRI on the RTT to act as island circuits. These loops were hardwired to the control unit at the HRI. To detect vehicles within the HRI, System 4 utilized a single radar unit placed on one side of the HRI. The vendor of this system claimed to be able to provide train direction information.

DATA COLLECTION

ITS data provided by each vendor was down loaded from each system real time or from the systems memory after each series of test runs. This information was compared to "actual" data of train speed, direction, length and id code manually recorded on a test control log. This effort will not require any interface or signal processing between the individual technologies.

During testing of alternative train and highway vehicle detection systems under Task Order 123 additional performance parameters that systems may record was monitored. This included one or more of the following parameters:

- Train direction
- Train speed
- Train length
- Train type or identification code

RESULTS/CONCLUSIONS:

All three of the available systems evaluated for their ability to provide ITS information were not set-up as “constant warning” systems. This means that after a train crossed over their approach sensors and initial train data was determined, the systems were not able to update any changes in train speed and/or direction. As a result, these systems were only able to provide accurate train information if the train did not change speed and/or direction in between the approach sensors and island sensors. Therefore, only train moves where direction and speed were held constant are included in the analysis.

System 1

System 1 was able to provided train direction, speed and length information. The results for System 1 are summarized in Table 1

Table 1. System 1 ITS Information

SYSTEM 1

RUN #	ACTUAL DIRECTION	ACTUAL SPEED	ACTUAL TRAIN LENGTH	DETECTED DIRECTION	DETECTED SPEED	DETECTED TRAIN LENGTH
101	CCW	5	712	CCW	5.0	842
102	CCW	5	712	CCW	4.0	733
103	CW	5	712	CW	4.0	707
104	CW	5	712	CW	4.0	633
105	CCW	10	712	CCW	9.0	703
106	CW	10	712	CW	9.0	687
107	CCW	10	712	CCW	10.0	727
108	CW	10	712	CW	10.0	730
109	CCW	20	712	CCW	19.0	743
110	CW	20	712	CW	19.0	712
111	CCW	35	712	CCW	35.0	746
112	CCW	35	712	CCW	35.0	734
113	CCW	50	712	CCW	48.0	752
114	CCW	50	712	CCW	50.0	754
115	CCW	65	57	CCW	68.0	91
116	CCW	65	57	CCW	64.0	88
117	CCW	80	57	CCW	79.0	88
118	CCW	80	57	CCW	82.0	92
119	CCW	80	57	CCW	123.0	83
120	CW	100	57	CW	101.0	86
121	CW	100	57	CW	101.0	86
122	CW	100	57	CW	97	82
123	CW	60	57	CW	61	83
124	CCW	120	600	CCW	*	*
125	CCW	120	600	CCW	*	*
201	CW	30-5	712	CW	30	721
202	CW	30-5	712	CW	31	735
203	CCW	5-35	712	CCW	4.0	742
204	CW	5-35	712	CW	5.0	715

*System failed during time period when 120 mph trains were operated

System 2

System 2 was able to provided train direction and train speed information. The results for System 2 are summarized in Table 2.

Table 2. System 2 ITS Information

SYSTEM 2

RUN #	ACTUAL DIRECTION	ACTUAL SPEED	ACTUAL TRAIN LENGTH	DETECTED DIRECTION	DETECTED SPEED	DETECTED TRAIN LENGTH
101	CCW	5	712	CCW	5.6	*
102	CCW	5	712	CCW	5.6	*
103	CW	5	712	CW	5.0	*
104	CW	5	712	CW	5.0	*
105	CCW	10	712	CCW	10.6	*
106	CW	10	712	CW	9.9	*
107	CCW	10	712	CCW	11.2	*
108	CW	10	712	CW	9.9	*
109	CCW	20	712	CCW	21.8	*
110	CW	20	712	CW	19.3	*
111	CCW	35	712	CCW	37.9	*
112	CCW	35	712	CCW	38.5	*
113	CCW	50	712	CCW	49.7	*
114	CCW	50	712	CCW	52.2	*
115	CCW	65	57	CCW	70.2	*
116	CCW	65	57	CCW	70.9	*
117	CCW	80	57	CCW	87.0	*
118	CCW	80	57	CCW	87.0	*
119	CCW	80	57	CCW	86.4	*
120	CW	100	57	CW	105.7	*
121	CW	100	57	CW	106.3	*
124	CCW	120	600	CCW	124.2	
125	CCW	120	600	CCW	123.8	
201	CW	30-5	712	CW	*	*
202	CW	30-5	712	CW	*	*
203	CCW	5-35	712	CCW	*	*
204	CW	5-35	712	CW	*	*

* System 2 was not able to determine train length, and did not display a speed during runs when train speeds changed from 5 to 30 mph or 30 to 5 mph.

System 4

System 4 was able to provide train direction information. The results for System 3 are summarized in Table 3.

Table 3. System 4 ITS Information

SYSTEM 4

RUN #	ACTUAL DIRECTION	ACTUAL SPEED	ACTUAL TRAIN LENGTH	DETECTED DIRECTION	DETECTED SPEED	DETECTED TRAIN LENGTH
101	CCW	5	712	CCW	*	*
102	CCW	5	712	CCW	*	*
103	CW	5	712	CW	*	*
104	CW	5	712	CW	*	*
105	CCW	10	712	CCW	*	*
106	CW	10	712	CW	*	*
107	CCW	10	712	CCW	*	*
108	CW	10	712	CW	*	*
109	CCW	20	712	CCW	*	*
110	CW	20	712	CW	*	*
111	CCW	35	712	CCW	*	*
112	CCW	35	712	CCW	*	*
113	CCW	50	712	CCW	*	*
114	CCW	50	712	CCW	*	*
115	CCW	65	57	CCW	*	*
116	CCW	65	57	CCW	*	*
117	CCW	80	57	CCW	*	*
118	CCW	80	57	CCW	*	*
119	CCW	80	57	CCW	*	*
120	CW	100	57	CW	*	*
121	CW	100	57	CW	*	*
124	CCW	120	600	CCW	*	*
125	CCW	120	600	CCW	*	*
201	CW	30-5	712	CW	*	*
202	CW	30-5	712	CW	*	*
203	CCW	5-35	712	CCW	*	*
204	CW	5-35	712	CW	*	*

* System 4 was only able to display train direction.

(blank)