



U.S. Department of
Transportation

Federal Railroad
Administration

High-Speed Rail Turnout Literature Review

Office of Research,
Development,
and Technology
Washington, DC 20590



NOTICE

This document is disseminated under the sponsorship of the Department of Transportation in the interest of information exchange. The United States Government assumes no liability for its contents or use thereof. Any opinions, findings and conclusions, or recommendations expressed in this material do not necessarily reflect the views or policies of the United States Government, nor does mention of trade names, commercial products, or organizations imply endorsement by the United States Government. The United States Government assumes no liability for the content or use of the material contained in this document.

NOTICE

The United States Government does not endorse products or manufacturers. Trade or manufacturers' names appear herein solely because they are considered essential to the objective of this report.

REPORT DOCUMENTATION PAGE*Form Approved
OMB No. 0704-0188*

Public reporting burden for this collection of information is estimated to average 1 hour per response, including the time for reviewing instructions, searching existing data sources, gathering and maintaining the data needed, and completing and reviewing the collection of information. Send comments regarding this burden estimate or any other aspect of this collection of information, including suggestions for reducing this burden, to Washington Headquarters Services, Directorate for Information Operations and Reports, 1215 Jefferson Davis Highway, Suite 1204, Arlington, VA 22202-4302, and to the Office of Management and Budget, Paperwork Reduction Project (0704-0188), Washington, DC 20503.

1. AGENCY USE ONLY (Leave blank)		2. REPORT DATE August 2016	3. REPORT TYPE AND DATES COVERED Literature Review - July 2013	
4. TITLE AND SUBTITLE High-Speed Rail Turnout Literature Review			5. FUNDING NUMBERS Contract No. DTFR53-12-C-00008	
6. AUTHOR(S) and FRA COTR Xinggao Shu and David Davis, TTCI			8. PERFORMING ORGANIZATION REPORT NUMBER	
7. PERFORMING ORGANIZATION NAME(S) AND ADDRESS(ES) Transportation Technology Center, Inc. 55500 DOT Road Pueblo, Colorado 81001			10. SPONSORING/MONITORING AGENCY REPORT NUMBER DOT/FRA/ORD-16/34	
9. SPONSORING/MONITORING AGENCY NAME(S) AND ADDRESS(ES) U.S. Department of Transportation Federal Railroad Administration Office of Railroad Policy and Development Office of Research, Development and Technology Washington, DC 20590			11. SUPPLEMENTARY NOTES COTR: Sung Lee	
12a. DISTRIBUTION/AVAILABILITY STATEMENT This document is available to the public through the FRA Web site at http://www.fra.dot.gov .			12b. DISTRIBUTION CODE	
13. ABSTRACT (Maximum 200 words) High-speed rail (HSR) turnout design criteria generally address unbalanced lateral acceleration or cant deficiency (CD), cant deficiency change rate (CDCR), and entry and exit jerk. Various countries have adopted different design values for their HSR systems based on their unique experiences and operating conditions. The design criteria (e.g., one for unbalanced lateral accelerations and jerk) have a direct influence on passenger ride comfort, but cannot be used as performance indices because they only account for kinematic responses, not dynamic responses. In North America, vehicle and turnout dynamic performances must comply with ride comfort and safety standards, such as FRA Track Safety Standards, Part 213. In a worldwide market, vehicle and track performance will most likely comply with ISO 2631. Switch rail optimization methodologies, such as Kinematic Gage Optimization and rail reprofiling, have demonstrated their effectiveness in reducing wheel force, rail force and rail wear through improved axle steering capability. The presteer switch was originally designed for North American low-speed turnouts, and its performance on HSR should be examined. Track stiffness uniformity along a turnout is critical for HSR operation. Proper track transition and optimal track stiffness can reduce wheel and rail impact forces while improving ride quality.				
14. SUBJECT TERMS Turnout geometry and design criteria, switch rail optimization, track stiffness, components			15. NUMBER OF PAGES 32	
			16. PRICE CODE	
17. SECURITY CLASSIFICATION OF REPORT Unclassified	18. SECURITY CLASSIFICATION OF THIS PAGE Unclassified	19. SECURITY CLASSIFICATION OF ABSTRACT Unclassified	20. LIMITATION OF ABSTRACT	

NSN 7540-01-280-5500

Standard Form 298 (Rev. 2-89)
Prescribed by ANSI Std. Z39-18
298-102

METRIC/ENGLISH CONVERSION FACTORS

ENGLISH TO METRIC

METRIC TO ENGLISH

<p>LENGTH (APPROXIMATE)</p> <p>1 inch (in) = 2.5 centimeters (cm)</p> <p>1 foot (ft) = 30 centimeters (cm)</p> <p>1 yard (yd) = 0.9 meter (m)</p> <p>1 mile (mi) = 1.6 kilometers (km)</p>	<p>LENGTH (APPROXIMATE)</p> <p>1 millimeter (mm) = 0.04 inch (in)</p> <p>1 centimeter (cm) = 0.4 inch (in)</p> <p>1 meter (m) = 3.3 feet (ft)</p> <p>1 meter (m) = 1.1 yards (yd)</p> <p>1 kilometer (km) = 0.6 mile (mi)</p>
<p>AREA (APPROXIMATE)</p> <p>1 square inch (sq in, in²) = 6.5 square centimeters (cm²)</p> <p>1 square foot (sq ft, ft²) = 0.09 square meter (m²)</p> <p>1 square yard (sq yd, yd²) = 0.8 square meter (m²)</p> <p>1 square mile (sq mi, mi²) = 2.6 square kilometers (km²)</p> <p>1 acre = 0.4 hectare (he) = 4,000 square meters (m²)</p>	<p>AREA (APPROXIMATE)</p> <p>1 square centimeter (cm²) = 0.16 square inch (sq in, in²)</p> <p>1 square meter (m²) = 1.2 square yards (sq yd, yd²)</p> <p>1 square kilometer (km²) = 0.4 square mile (sq mi, mi²)</p> <p>10,000 square meters (m²) = 1 hectare (ha) = 2.5 acres</p>
<p>MASS - WEIGHT (APPROXIMATE)</p> <p>1 ounce (oz) = 28 grams (gm)</p> <p>1 pound (lb) = 0.45 kilogram (kg)</p> <p>1 short ton = 2,000 pounds (lb) = 0.9 tonne (t)</p>	<p>MASS - WEIGHT (APPROXIMATE)</p> <p>1 gram (gm) = 0.036 ounce (oz)</p> <p>1 kilogram (kg) = 2.2 pounds (lb)</p> <p>1 tonne (t) = 1,000 kilograms (kg) = 1.1 short tons</p>
<p>VOLUME (APPROXIMATE)</p> <p>1 teaspoon (tsp) = 5 milliliters (ml)</p> <p>1 tablespoon (tbsp) = 15 milliliters (ml)</p> <p>1 fluid ounce (fl oz) = 30 milliliters (ml)</p> <p>1 cup (c) = 0.24 liter (l)</p> <p>1 pint (pt) = 0.47 liter (l)</p> <p>1 quart (qt) = 0.96 liter (l)</p> <p>1 gallon (gal) = 3.8 liters (l)</p> <p>1 cubic foot (cu ft, ft³) = 0.03 cubic meter (m³)</p> <p>1 cubic yard (cu yd, yd³) = 0.76 cubic meter (m³)</p>	<p>VOLUME (APPROXIMATE)</p> <p>1 milliliter (ml) = 0.03 fluid ounce (fl oz)</p> <p>1 liter (l) = 2.1 pints (pt)</p> <p>1 liter (l) = 1.06 quarts (qt)</p> <p>1 liter (l) = 0.26 gallon (gal)</p> <p>1 cubic meter (m³) = 36 cubic feet (cu ft, ft³)</p> <p>1 cubic meter (m³) = 1.3 cubic yards (cu yd, yd³)</p>
<p>TEMPERATURE (EXACT)</p> <p>$[(x-32)(5/9)]\text{ }^{\circ}\text{F} = y\text{ }^{\circ}\text{C}$</p>	<p>TEMPERATURE (EXACT)</p> <p>$[(9/5)y + 32]\text{ }^{\circ}\text{C} = x\text{ }^{\circ}\text{F}$</p>

QUICK INCH - CENTIMETER LENGTH CONVERSION

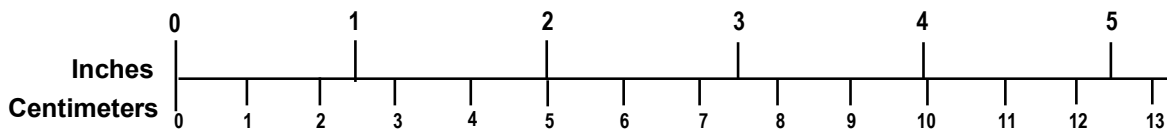

QUICK FAHRENHEIT - CELSIUS TEMPERATURE CONVERSION

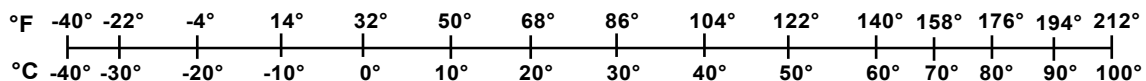

For more exact and or other conversion factors, see NIST Miscellaneous Publication 286, Units of Weights and Measures. Price \$2.50 SD Catalog No. C13 10286

Updated 6/17/98

Contents

Executive Summary	1
1. Introduction	2
1.1 Objectives	4
2. Turnout Geometry and Design Criteria	5
2.1 Kinematic Acceleration Criteria	6
2.2 Geometric Alignment	10
2.3 Axle Load	11
3. Switch Rail Optimization	13
3.1 Housed Point	13
3.2 Kinematic Gage Optimization	13
3.3 Presteer Switch	14
3.4 CATFERSAN Design	15
3.5 Conformal Switch Rail Profile	16
3.6 Switch Rail Longitudinal Running Surface	16
3.7 Rail Cant	17
4. Track Stiffness	18
5. Components	19
5.1 Plate Work	19
5.2 Crossties	19
5.3 Switch Throw Mechanisms	20
6. Conclusion	21
7. References	22
Abbreviations and Acronyms	25

Illustrations

Figure 1. Turnout Alignment Options 2

Figure 2. Turnout Geometry: Curvature (D) versus Position (s)..... 11

Figure 3. KGO Concept 13

Figure 4. Presteer Switch (showing both main line and branch line switch points closed)..... 14

Figure 5. CATFERSAN Concept 15

Figure 6. Conformal Switch Point Cross Section Profile 16

Figure 7. Multi-Tie Plate for Frog Heels 19

Figure 8. Crossties with Rubber Pads on Bottom Surface..... 20

Tables

Table 1. Comparison of Turnout Practices between North American Railroads and HSR in Europe and Asia.....	3
Table 2. Comparisons of Design Criteria Values Used in HSR Systems.....	7
Table 3. Perception of Ride Comfort according to ISO-2631-1.....	9
Table 4. Ride Evaluation Scale as per Sperling Ride Index.....	10
Table 5. HSR Vehicle Axle Load.....	12

Executive Summary

The Federal Railroad Administration (FRA) contracted with voestalpine Nortrak to conduct a high-speed rail (HSR) research project titled “High-Speed Rail Turnouts for the USA” (Contract No. DTFR53-12-C-00008). Transportation Technology Center, Inc. (TTCI) was subcontracted by Nortrak to conduct the following tasks:

- Task 1: Literature Review
- Task 2: Turnout Configuration Design Review
- Task 3: Modeling
- Task 4: Configuration Layout Support Services
- Task 5: Report

TTCI reviewed existing HSR turnout designs and technical standards, especially those used in Europe and Asia. TTCI analyzed and compared design differences and methodologies to provide references. This report is the Task 1 deliverable.

HSR turnout design criteria generally address unbalanced lateral acceleration or cant deficiency (CD), cant deficiency change rate (CDCR), and entry and exit jerk. Various countries have adopted different design values for their HSR systems based on their unique experiences and operating conditions.

The design criteria (e.g., one for unbalanced lateral accelerations and jerk) have a direct influence on passenger’s ride comfort, but cannot be used as performance indices because they only account for kinematic responses, not dynamic responses. In North America, vehicle and turnout dynamic performances comply with ride comfort and safety standards, such as FRA Track Safety Standards, Part 213. In a worldwide market, vehicle and track performance will also likely comply with ISO 2631, as well.

Switch rail optimization methodologies, such as Kinematic Gage Optimization and rail reprofiling, have demonstrated their effectiveness in reducing wheel and rail force and rail wear through improved axle steering capability. The presteer switch was originally designed for North American low-speed turnout, and its performance on HSR should be examined.

Track stiffness uniformity along a turnout is critical for HSR operation. Proper track transition and optimal track stiffness can reduce wheel and rail impact forces while improving ride quality.

1. Introduction

Most North American turnouts have evolved to be simple and robust for heavy axle load service. Turnouts are intended to be durable for low-speed diverging traffic. This is achieved with simple designs. Alignments use circular curves without easement spirals. Most designs used in the freight network lack tangential (i.e., switches without an entry angle) alignments. By contrast, effective turnout designs use secant geometry, where the diverging route track centerline is outside the straight route track centerline. This alignment creates a turnout with a kink or nonzero entry angle at the point of switch. This alignment design is favored over tangential designs for slow-speed diverging, heavy-axle load traffic operators because the switch points are shorter and thicker. In general, the alignment design components have a longer service life, even though maximum forces and ride quality are worse than under tangential designs.

The nonsymmetrical or handed turnout designs typically used in North America were influenced by the track safety rules that govern the allowable speed on the diverging route. The allowable speed in curves is governed by the maximum permissible CD or amount of superelevation in the curve. The entry angle kink allows the turnout to have a larger radius closure curve (lower CD for the same speed) than tangential designs of the same length. Ironically, the design that generates higher forces has the higher allowable operating speed. Figure 1 illustrates the relationship between kink angle and curve radius.

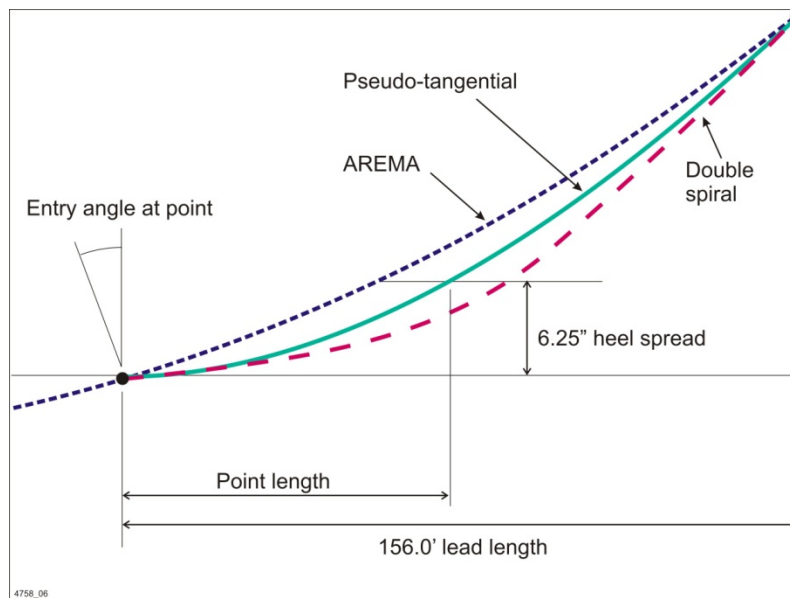

Figure 1. Turnout Alignment Options

Implementation of HSR in North America would benefit from a radically different approach to the current turnout engineering practices. Table 1 summarizes the comparison of turnout practices between freight and passenger railroads in North America and HSR in Europe and Asia.

Table 1. Comparison of Turnout Practices between North American Railroads and HSR in Europe and Asia

Design Element	North American Railroads		Europe and Asia
	Typical	Best Practice	HSR Best Practice
Switch alignment	Secant, nontangential	Tangential	Tangential, spiral, gage manipulation for steering
Switch running surface cross section profile	Nonconformal	Conformal (e.g., rail shape)	Canted rail shape
Switch running surface longitudinal profile	¼-inch riser, 12-inch second cut	¼-inch riser,* 60-inch second cut	No riser
Switch rail section	Machined RE (Railway Engineering) section, undercut base	Asymmetric section	Asymmetric section
Rail cant	Flat	Flat with cant provided by rail profiles**	To match open track
Plate work	Single tie plates	Multi-tie plates	Variable stiffness supports
Frog type	Fixed point, railbound manganese	Movable point frog (MPF)	MPF
Frog profile	Flat	Conformal	Conformal, no point depression
Guardrails	Circular entry	None with MPF, Circular entry with fixed point	None on main line
Crossties	Timber	Concrete	Concrete with under-tie pads
Crosstie configuration	Long ties under frog	Long ties under frog	Long ties under frog
Switch machine	Electric with helpers	Electric, several or with rigid helpers	Hydraulic in tie, with slaves
Switch machine location	On head block ties	In tie	In tie
Condition monitoring systems	None	None	On switch and MPF

* Best practices are evolving rapidly.

**Currently, there are a limited number of in-service domestic designs that include canted rails, but do not include rising points.

North American turnout designs have a bias toward lower initial cost and more durability under heavy axle loads. This bias can be seen in choices such as wheel risers in the switch longitudinal running surface profile and depressed point frogs to accommodate a wide variety of worn wheel profiles. These designs will perform consistently well under a wide variety of vehicle designs and conditions at the expense of poorer dynamic performance.

While there is much to be learned from European and Asian experiences with HSR, innovations in the following areas will significantly improve turnout and vehicle dynamic performance and lower track maintenance costs:

- Transitioned turnout geometric alignment
- Optimized rail shape, cant, and track gage with favorable wheel and rail contact geometry
- Uniform track support system with optimal stiffness and damping

Review and analysis of these innovations and service-proven HSR turnout technologies from Europe and Asia will provide valuable references for developing new designs in North America.

1.1 Objectives

One of the objectives of this report is to review existing HSR turnout designs and practices, especially those used in HSR in Europe and Asia. Another objective is to analyze and compare design differences and methodologies in order to provide references for developing new designs.

2. Turnout Geometry and Design Criteria

Vehicles running through the diverging route of a turnout behave similarly to vehicles running through a short curve. And while most North American railroads distinguish turnouts by frog number, the radius of the closure curve is used to establish diverging route operating speed limits. The actual geometry of a turnout is much more complicated than that of a curve. Turnout design has to follow some specific criteria to meet the operation requirements, and additional constraints are applied to make it cost effective. Among those criteria and constraints, the following three parameters, which are derived from kinematic acceleration based on curve radius and speed, are used for HSR turnout design:

- Maximum unbalanced lateral acceleration or maximum CD
- Maximum change rate of unbalanced lateral acceleration or maximum CDCR
- Maximum entry and exit jerk

The centrifugal acceleration experienced by a body that travels over a circular curve of radius R at a speed of v is

$$a=v^2/R \quad (1)$$

where a is centrifugal acceleration.

Since there is no superelevation in a turnout, the value of the unbalanced lateral acceleration is the same as the centrifugal acceleration.

CD or unbalanced superelevation is another way to characterize the unbalanced lateral acceleration. When track gage and gravity are included, $CD \approx 4.0 v^2 / R$, for English units, CD is in inches, v is in mph, and R is in feet, or $CD \approx 11.8 v^2 / R$, where CD is in millimeters (mm), v is in km/h, and R is in meters (m). The conversion from a (m/s^2) to CD (mm) can be derived from:

$$CD(mm) \approx 153 * a (m/s^2) \quad (2)$$

CDCR is defined as the first derivate of the unbalanced lateral acceleration (i.e., $CDCR = da / dt$). CDCR is also referred to as transition rate in publications.

There is usually a sudden CD change at the entry of the turnout on diverging track where a curve track starts guiding the vehicle in the diverging direction. The sudden change of CD at the entry point makes CDCR a meaningless infinity value.

A vehicle has a certain length; its mass is not concentrated in one point. Unbalanced lateral acceleration will not act with its whole value in the vehicle's center of mass until the whole length of the vehicle is in the diverging curve. Before its last wheelset is located at the entry of the diverging track, the vehicle center of mass is experiencing a compromised unbalanced lateral acceleration due to the fact that the front part of the vehicle body is in the curve, and the rear part of the body is still on tangent. For this situation, the concept of jerk or the "virtual transition rate" was developed.

The vehicle is presumed to be in virtual transition when it is halfway in the tangent and halfway in the curve. The jerk is defined, as shown by the formula below, within a truck spacing distance, with half of truck spacing distance ahead of switch point and another half behind:

$$Jerk = \frac{a(\text{or } CD)}{L/v} \quad (3)$$

Where a (or CD) is the unbalanced lateral acceleration (or cant deficiency) at the leading truck location, L is the truck spacing, and v is the running speed. Jerk is only used for the entry or exit of the diverging track of the turnout because the sudden changes of curvatures on entry and exit or short curves cause higher jerks than those on other locations of the turnout.

2.1 Kinematic Acceleration Criteria

2.1.1 Unbalanced Lateral Acceleration

Three standards recommend unbalanced lateral acceleration criterion values for turnout design [1–3]. UIC 711:1, Switch with Simple Diverging Track, recommends 80 to 100 mm (100 mm being the maximum) cant deficiency on the diverging route [1].

AREMA, Chapter 5, states that the turnout speeds are to be calculated based on 3 inches (76.2 mm) of cant deficiency [2].

BS EN 13802-3, Section 7.1.2, Switch and Crossing Layouts, states: “The limiting values for an abrupt change of cant deficiency in the tracks of a switch and crossing layout shall be as specified in Table 2a [3].” Shown here is a version of the table that appears in the referenced document:

Table 2a. Limiting Values of Abrupt Change of Cant Deficiency (ΔI_{lim}) – High-Speed Lines

Speed V [km/h]	$V \leq 70$	$70 < V \leq 170$	$170 < V \leq 230$
Recommended values ΔI_{lim} (mm)	100	80	60
Maximum limiting values ΔI_{lim} [mm]	120	105	85

2.1.2 Unbalanced Lateral Acceleration Change Rate

BS EN 13802-3, Section 9.2.2.2, Range of Parameter of Clothoid (A), states: “The range of the parameter of clothoid (A), for existing turnouts with curves of variable curvature (clothoid curves), is shown in Figure 7. This range corresponds to a rate of change of cant deficiency (dI/dt) of between 25 mm/s and 90 mm/s [3].” The figure gives values for A of 191 m to 362 m at 100 km/hr and 540 m to 1025 m at 200 km/hr. Thus, one can see that the length of the turnout increases more than linearly with increasing speed.

UIC 711 and AREMA do not have limit values on change rate for turnout design.

2.1.3 Entry Jerk

BS EN 13802-3, Section E.3.2, “Characteristic vehicle with a distance of 20 m between bogie centres” states: “The limiting values for the rate of change of cant deficiency at an abrupt change in curvature as function of time ($\Delta I/\Delta t$) for a characteristic vehicle with a distance of 20 m between bogie centres are specified in Table E.1.” Shown here is a version of the table that appears in the referenced document:

Table E1. Limiting Values for the Rate of Change of Cant Deficiency at an Abrupt Change in Curvature ($\Delta I/\Delta t$)

	S&C Layout	Plain Line
Recommended value [mm/s]	125	
Maximum limiting value [mm/s]	150	55

S&C is the abbreviation of switch and crossing. The abrupt change in curvature normally occurs in the switch point where curvature changes from 0 (line) to an initial limit curvature value of the spiral or curve. BS EN 13802-3, Section E.3.3, “Characteristic vehicle with a distance of 12,2 m and 10,06 m between bogie centres” states: “The limiting values for the rate of change of cant deficiency at an abrupt change in curvature as function of time ($\Delta/\Delta t$) for characteristic vehicles with distances of 12,2 m and 10,06 m between bogie centres are specified in Table E.2.” Shown here is a version of the table that appears in the referenced document:

Table E.2. Limiting Values for the Rate of Change of Cant Deficiency at an Abrupt Change in Curvature ($\Delta/\Delta t$)

	S&C layout	Plain line
Recommended value [mm/s]	35	35
Maximum limiting value [mm/s]	80	55

BS EN 13802-3 standard applies to both high-speed and conventional lines. The jerk value depends not only on the bogie spacing, but also on the running speed, as Equation 3 shows. The running speed of conventional low-speed passenger vehicles, which usually have shorter bogie spacing, is limited by the lower criteria values, as shown in Table E.2.

Even though these standards recommend limiting values for the unbalanced lateral acceleration (or CD), CDCR, and jerk, HSR systems in various countries adopted different values based on their own experiences and operational conditions. Table 2 summarizes the criterion values used in different HSR systems.

Table 2. Comparisons of Design Criteria Values Used in HSR Systems

HSR System (Country)	Unbalanced Lat. Accel.		Unbalanced Lat. Accel. Change Rate		Entry Jerk		Ref.
	(m/s ²)	CD (mm)	(m/s ³)	CDCR (mm/s)	(m/s ³)	(mm/s)	
SNCF No. 46 turnout (160km/h) (France)	0.59	90.3	0.23	35.2			4
SNCF No. 65 turnout (220km/h) (France)	0.56	85.7	0.22	33.7			4
Deutsche Bahn No. 39 Turnout (160km/h) (Germany)	0.49	75.0	0.4	61.2	1.0	153.0	4, 5
Deutsche Bahn No. 50 Turnout (220km/h) (Germany)	0.51	78.0	0.41	62.7	1.0	153.0	4, 5
Japan, No. 38 turnout (160 km/h)	0.47	71.9	0.55	84.2			4
China (220km/h)	0.5	76.5	0.6	91.8	1.0-1.3	153.0-198.9	6
Madrid–Seville high-speed line, 160 km/h (Spain)	Normal: 0.51 Max: 0.65	Normal: 78.0 Max: 99.5	Max: 0.40	61.2	Normal: 0.40 Max: 0.85 Exceptional: 1.20	Normal: 61.2 Max: 130.1 Exceptional: 183.6	7
Madrid–Barcelona high-speed line, 220 km/h (Spain)	0.5	76.5	0.6	91.8	1.1	168.3	7
OBB (Austria)	0.8	122.4	0.25	38.3	1.0	153.0	5
SBB (Switzerland)	0.8	122.4	0.2	30.6	1.2	183.6	5

Table 2 and the surveys found in references 4–13 show that the kinematic lateral acceleration criterion values used for turnout design are different from system (country) to system [4–13]. They are also different from normal speed lines and high-speed lines even within the same country. One reason that different criteria values are used is because vehicles have different designs to accommodate various operational constraints.

Turnouts, as part of the track infrastructure, are built for a railway vehicle to transport freight and or passengers. Even though there are turnout construction and maintenance standards, its dynamic performance has to be evaluated based on vehicle performances in terms of ride quality and safety.

Unbalanced lateral accelerations have a direct influence on passenger’s ride comfort, especially for HSR. Two standards, ISO 2631 [14, 15] and the Sperling Ride Index [16], are commonly used in transportation systems to evaluate passenger vehicle’s ride comfort performance.

ISO 2631 provides basic and additional evaluation methods based on the crest factor. The crest factor was defined as the modulus of the ratio of the maximum instantaneous peak value of the frequency-weighted acceleration signal to its root mean square (rms) value.

Weighted rms acceleration is the basic evaluation method when the crest factor is less than 9. When the basic evaluation method is not sufficient, the running rms method and fourth power vibration dose method are used. Guidance with respect to the use of evaluation methods and frequency weightings for health, comfort, and perception and for motion sickness are provided. The frequency range considered is:

- 0.5 Hz to 80 Hz for health, comfort and perception, and
- 0.1 Hz to 0.5 Hz for motion sickness.

The basic evaluation method uses frequency weighted rms accelerations and is defined by:

$$a = \left[\frac{1}{T} \int_0^T a_w^2(t) dt \right]^{\frac{1}{2}} \quad (4)$$

where $a_w(t)$ is the weighted acceleration as a function of time in meters per second squared (m/s^2), and T is the duration of the measurement in seconds. The duration of measurement shall be sufficient to ensure the proper range of frequencies analyzed and to ensure that the vibration is typical of the exposures that are being assessed. Detailed requirements can be found in the ISO 2631 standard.

The standard defines the total vibration value of weighted rms acceleration for all directions in respective positions.

As per ISO-2631-1, Table 3 gives approximate indications of likely reactions to various magnitudes of overall vibration values in public transport.

Table 3. Perception of Ride Comfort according to ISO-2631-1

Root Mean Square	Value Perception
Less than 0.315 m/ s ²	Not uncomfortable
0.315 m/ s ² to 0.63 m/ s ²	A little uncomfortable
0.5 m/s ² to 1 m/s ²	Fairly uncomfortable
0.8 m/s ² to 1.6 m/s ²	Uncomfortable
1.25 m/s ² to 2.5 m/s ²	Very uncomfortable
Greater than 2 m/s ²	Extremely uncomfortable

Based on the ISO 2631 methodologies described above, the maximum unbalanced lateral acceleration value, which is a kinematic acceleration and commonly used as a limit for turnout design, cannot be used directly for the evaluation of ride comfort. Instead, the dynamic carbody acceleration—both its magnitudes and frequencies—are needed to obtain a weighted rms acceleration value for evaluation.

To get a rough estimate of ride comfort by using the unbalanced lateral acceleration limit commonly used in turnout design, assuming the carbody is experiencing a max 0.65m/s² acceleration with a sine wave shape and 0.5 Hz frequency (corresponding to a run through a crossover in 2 seconds), the rms acceleration value can be calculated as 0.392 m/s² based on the principal frequency weightings in ISO 2631-1, which falls in the second level of perception (i.e., a little uncomfortable). A more accurate ride comfort evaluation can be conducted through dynamic simulations or measurements.

Sperling proposed a ride index and developed the Sperling Ride Index (W_z) method to evaluate the ride quality and comfort of railway vehicles [16]. The Sperling Ride Index is defined by the following equation:

$$W_z = \sqrt[10]{a^3 B^3} \quad (5)$$

Where a is the amplitude of the acceleration, and B is the acceleration weighting factor.

Two types of Sperling Ride Index are commonly used to evaluate the ride quality and comfort of railway vehicles: the ride quality index and the comfort index.

Table 4 gives the relationship between the Sperling Ride Index and vibration sensitivity. The evaluation scales for the Sperling Ride Index were constructed on the basis of vibration tests on people and were supplemented by other test results.

Table 4. Ride Evaluation Scale as per Sperling Ride Index

Ride Index W_z	Vibration Sensitivity
1	Just noticeable
2	Clearly noticeable
2.5	More pronounced but not unpleasant
3	Strong, irregular, but still tolerable
3.25	Very irregular
3.5	Extremely irregular, unpleasant, annoying, prolonged exposure intolerable
4	Extremely unpleasant; prolonged exposure harmful

The Sperling Ride Index and ISO 2631 evaluations are consistent in the vehicle's vertical vibration direction, but somewhat different in the vehicle's lateral direction. The Sperling Ride Index is convenient to use because it finally results in a pure number, which is more appropriate for comparing two or more different situations, while ISO 2631 rms value has overlaps in adjacent levels of perception. However, ISO 2631 is the most precise method and has been adopted by many countries and railway companies in the world.

High lateral acceleration causes not only the deterioration of ride comfort but also safety concerns. All the centrifugal forces on the components of the whole vehicle have to be balanced by the wheel and rail forces. A higher speed results in a bigger centrifugal forces and bigger lateral wheel and rail forces. The lateral forces are not equally distributed among axles; leading axles generally bear more lateral forces than trailing axles. Dynamic simulations are usually conducted to examine wheel and rail forces and corresponding safety criteria before prototypes are fabricated.

2.2 Geometric Alignment

Switch alignments have evolved from rudimentary to smooth as train speeds have increased. In North America, most turnouts on freight lines function economically for diverging route speeds at 40 mph and below. These designs use circular curves with nontangential entry. They have no superelevation and consist of flat plate work. More refined designs employ tangential entry to improve ride quality and reduce forces. Reduction of the switch entry angle is the most effective way to improve turnout performance [17–20]. Additional improvements include entry and exit spirals. While several spiral designs are advocated, most turnouts use a spiral of the clothoid form. Klauder advocates a spiral that rotates the vehicle center of gravity less [21].

For HSR turnout, to meet the kinematic acceleration criteria discussed above, the turnout geometric alignment has more constraints on entry and exit jerk. The track centerline geometric alignment is usually defined as a series of spiral (clothoid) or constant curve segments. When the speed and track center distance are given, the minimum length of each segment is determined by the acceleration criteria values and geometry functions such as curve, cubic parabola, and clothoid. Figure 2 shows typical HSR turnout alignments.



Figure 2. Turnout Geometry: Curvature (D) versus Position (s)

In Germany, simple circular curve layouts were used in turnouts in the 1980s. They were abandoned in the 1990s as speed increased, giving way to layouts with clothoid or cubic parabola turnouts to reduce the CDCR and jerk over the diverging track.

With the Paris Sud-Est high-speed line, the French national railroad (SNCF) uses turnouts with a diverging track consisting of a transition curve (cubic parabola), tangent to the main line, with an initial radius and ends with an infinite radius at the frog nose.

Swiss railroads (SBB) design turnouts with a diverging track consisting of two clothoid spirals. This solution, known as a tip clothoid, or spiral-spiral (S-S layout), allows a reduction in the switch's deviation angle with respect to the French geometry. The S-S layout consists of two asymmetrical clothoids with different parameters connected to each other.

The tip clothoid solution, however, has the disadvantage of generating high unbalanced lateral accelerations when trains run over the turnout at high speeds. To reduce the lateral acceleration, the spiral-curve-spiral (S-C-S) layout (known as the plateau clothoid) turnout, which uses two clothoid spirals connected by a circular curve, was developed for Spanish high-speed lines from Madrid to Seville and to Barcelona. The S-C-S layout is also used in Germany and China high-speed turnouts.

2.3 Axle Load

Unbalanced lateral acceleration on the vehicle is balanced by wheel and rail forces. Wheel and rail forces in turnouts usually increase with speed and axle load. The axle load has a significant effect on turnout and vehicle safety performances including track panel shift, gage widening, flange climb derailment, and wheel unloading. Axle loads used in different HSR systems range from 11.1 to 23 tons, as Table 5 lists.

Table 5. HSR Vehicle Axle Load

Country	Vehicle	Axle Load (tonnes)
Japan	0, 100 series	16.1
	300 series	11.3
	500, 700 series	11.1
China	Passenger car running on dedicated high-speed line	17.0
	Freight car running on shared line	23.0
Germany	ICE 1, ICE 2, Passenger car on shared line	19.0
	ICE 3, ICEM 4	16.0
France	TGV-R	17.0
USA	Acela, Power car	22.7
	Acela, Coach car	16.4

3. Switch Rail Optimization

Because spiral and tangential alignments require extremely thin sections, many designs attempt to protect the switch point end in various ways. For example:

- “Housing” the point under the stock rail
- Manipulating track gage to improve axle steering
- Manipulating running surface profiles to improve axle steering

In addition, HSR stock and switch rails are all canted. These optimization methodologies are used to change switch rail shape or position with favorable wheel and rail contact geometry for better axle steering.

3.1 Housed Point

Undercut stock rails are very effective at extending the life of the switch point [22]. This strategy is effective because the two mating components, the point and its stock rail, are replaced as a pair. Extending the life of the shorter lived component at the expense of the longer lived one will likely result in an increase in the life of the pair. Housed points take this process further in favoring the point over the stock rail. However, housed points affect the gage line of the stock rail and are more likely to degrade mainline ride quality.

3.2 Kinematic Gage Optimization

Track gage manipulation is used to steer wheelsets away from the switch point tip. This strategy, known by the trade name Kinematic Gage Optimization (KGO) has been successfully employed by BWG and its voestalpine successor in many applications [5]. Figure 3 shows the KGO concept. The gage widening causes a rolling radius difference on the wheelset so that the wheelset steers away from the switch point on either route. For the diverging route, this helps the wheelset steer down the diverging path. For both routes, the switch point can be thicker than with the nominal alignment. This provides for a more robust point with a longer wear life.

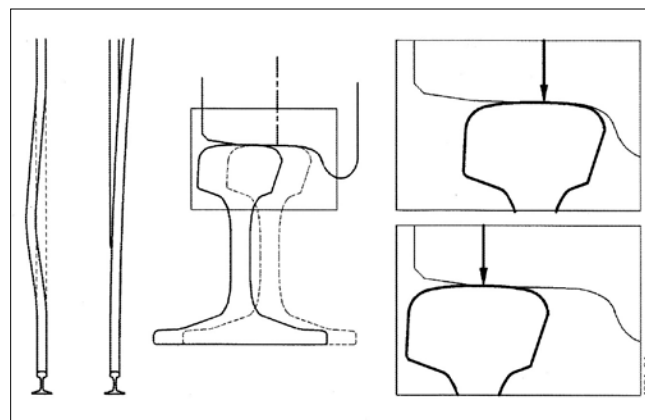

Figure 3. KGO Concept

3.3 Presteer Switch

The presteer switch was originally designed for low-speed North American turnouts that usually have noticeable kink angle [23]. Figure 4 shows the presteered switch design and its differences compared with the traditional switch design.

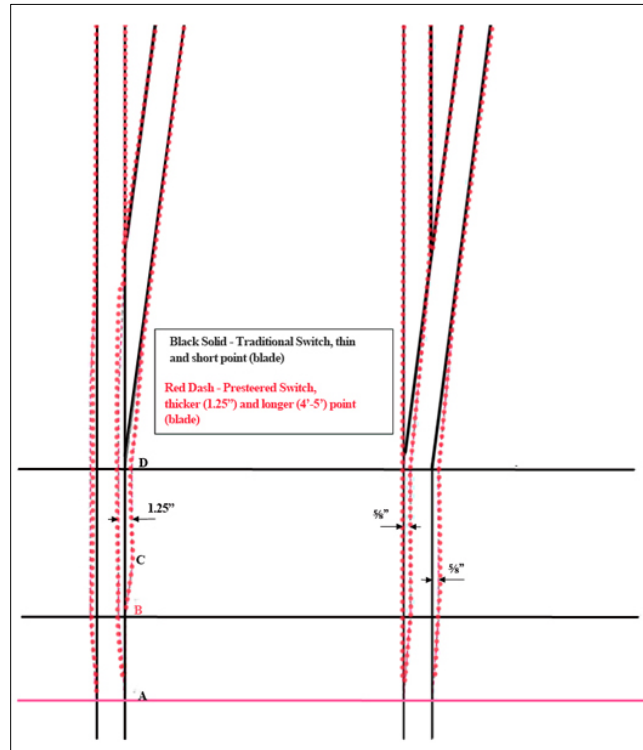

Figure 4. Presteer Switch (showing both main line and branch line switch points closed)

The objective of a presteer switch is to steer the wheelset away from the most vulnerable part of the switch point by separating the start of the switch point from the alignment “point of switch” (i.e., the location where the diverging route begins to deviate from the main route). In this way, the risk of a switch failure is lowered. By manipulating alignment, gage, and running surface profiles ahead of the point of switch, wheelsets may be positioned to minimize the most severe contact with the switch point. Each axle is presteered to a negative angle of attack (AOA) ahead of switch point, so the wheel runs away laterally from the switch point. There are two benefits to this design:

- It virtually reduces the kink angle. The negative AOA ahead of the switch point partially offsets the switch kink angle and reduces the maximum AOA in the switch; lower AOA means lower lateral force.
- The wheel contacts the switch rail on the thicker part of the blade and causes less damage on the switch point.

The presteer design differs from previous designs by extending the switch points beyond the point of switch. This new design will provide a more robust switch for heavy axle load applications and will accommodate a wider range of wheel profiles.

Simulation showed that the proposed presteer switch has the following advantages compared with the traditional switch [23]:

- It reduces the maximum lateral impact force by 28 percent and 18 percent for loaded and empty freight cars with new wheels, respectively, at speeds up to 40 mph.
- It reduces the maximum lateral impact force by 5 percent and 9 percent for loaded and empty freight cars with hollow wheels, respectively, at speeds up to 40 mph.
- It has a thicker cross section where the maximum lateral impact occurs.

For HSR, presteer effect on axle steering and vehicle ride quality should be examined. The fabrication and maintenance costs could outweigh the benefits as turnout sizes get bigger.

3.4 CATFERSAN Design

Another method of wheelset steering is the CATFERSAN design [7]. Figure 5 shows the CATFERSAN concept.

This design uses rail cross section variations to develop the desired rolling radius difference in the wheelsets. This method would appear to have advantages over the KGO method in that track gage is nominal throughout. The KGO design makes adjusting horizontal ballasted track alignment with automatic aligning equipment more difficult. The disadvantage is that the profile must be maintained. If it is not, the steering benefit will be lost. It may also be less robust for accommodating a wide range of wheel tread profiles. Also, the switch points are not thicker than with nominal alignment because the stock rail position is unchanged.

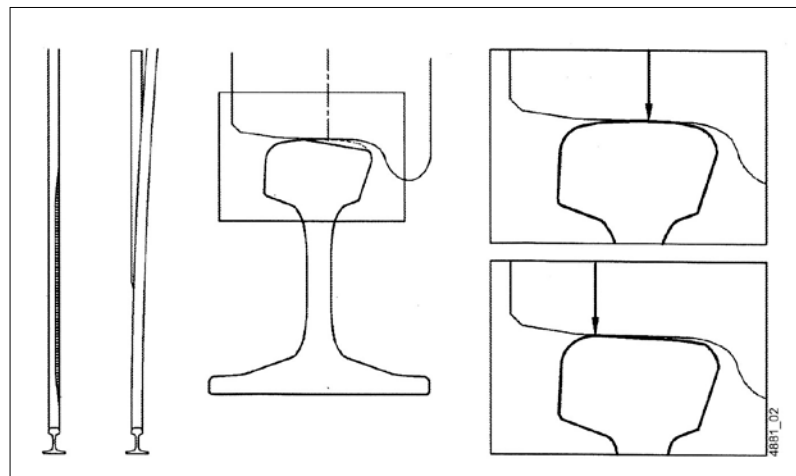

Figure 5. CATFERSAN Concept

The wheel and rail contact on the mainline stock rail with smaller rolling radius steers the wheelset away from mainline switch point, thus benefitting mainline movement. However, for diverging movement, the profile on the mainline stock rail (before the switch point begins

carrying load) could steer the axle to the unfavorable direction and cause more wear and impact on the switch. How to improve the diverging route performance is not clear from the CATFERSAN concept.

3.5 Conformal Switch Rail Profile

Traditionally, switch points are made from rail sections. To avoid any abrupt transition from the stock rail onto the switch point, a longitudinal slope is machined into the end of the point rail. Before CNC machining capability, the slope was made with a planer. This produced the intended slope on the gage line of the point, but also left a flat (horizontal) top surface. With 260 Brinell hardness rails, the running surface quickly wore into a conformal shape.

With modern rail steels used for switch points, the nonconformal shape will fatigue before it deforms into a conformal shape. Thus, a more conformal shape is required to reduce dynamic loading, switch point running surface maintenance, and wheel and rail contact stresses. An example of a conformal profile is the one developed by Wu, et al. [24] and shown in Figure 6. This profile has reduced wear by about 50 percent.

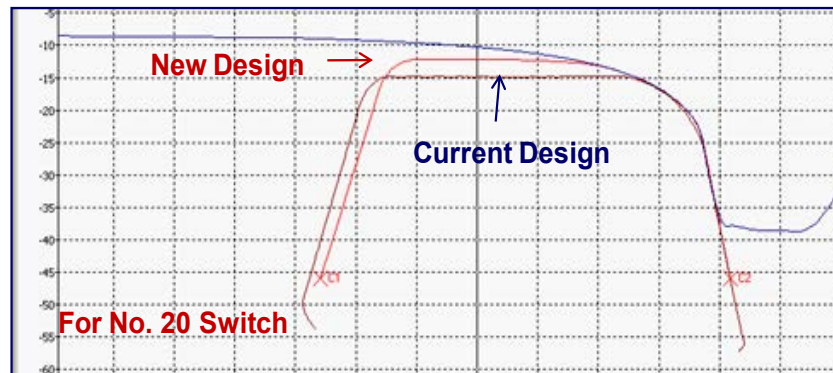

Figure 6. Conformal Switch Point Cross Section Profile

3.6 Switch Rail Longitudinal Running Surface

Integral to the profile of the point is the longitudinal slope. The slope should be gentle enough to minimize vertical dynamic loading. But, it must be large enough to avoid any blunt strikes from wheels in facing point moves. Use of wheel risers, as is the practice in North America, should not be needed in high-speed operations. Wheel tread width and profiles will be designed by high-speed passenger operators to eliminate this need.

Another design consideration of the point slope is that the point be substantial enough to carry vertical loading when it is first applied. This is dependent on wheel load and wheel and rail profile match. As a rule of thumb, a switch point width of 15–20 millimeters is needed to carry passenger wheel loads [25]. Methods, such as KGO, that allow a thicker switch point are recommended to limit the length of the switch point slope.

The choice of rail section for a switch point should be made with several design considerations in mind. The point should be stable with a wide base. It also should not prevent gage side fastening of the stock rail to the crossties (i.e., there should be clearance between the switch point and the stock rail for gage side fasteners on the stock rail). Ideally, the switch should have

dynamic track properties similar to the surrounding track. The use of short, asymmetric sections for switch points is almost universal for high-speed applications. This section allows for gage side hold down and integral slide plates. The stock rails can be canted independent of the switch points. Running surface profile can be machined to match the plain track rail section.

3.7 Rail Cant

Rail cant throughout the turnout should match that used in the surrounding track. Abrupt changes result in lateral forces and accelerated wear of the running surfaces. Traditionally, switches are built on level plate work, which simplifies manufacture and operation. The switch points can slide easily on level plate work. Adding rail cant complicates the switch design where changing stock rail and switch point undercuts are concerned. For HSR, both stock rails and switch rails are canted (1:40) with favorable wheel and rail contact geometry to decrease wheel and rail wear and improve axle steering.

4. Track Stiffness

Track stiffness experienced by a train will vary along the track. Variations in track stiffness will induce transient and high frequency wheel and rail impact, which will intensify track degradation such as increased wear, fatigue, and differential track settlement.

Both mass and stiffness change rapidly in and around a turnout. The bending stiffness of the switch rail differs from that of the stock rail; the sleepers have different lengths and distances, and the crossing (the frog) is stiffer (in bending) and has a larger mass than the surrounding rails. Using a numerical model, Andersson and Dahlberg [26, 27] investigated the load impact at the crossing nose (i.e., frog point) when a wheel moves (at the frog) from the wing rail to the nose. They found that the severity of the load impact depends on variations of track stiffness, variations of mass distribution, and geometric irregularities at the crossing.

When the trains run from the stock rail to switch rail, the vertical impact will come from the vertical geometric irregularities and stiffness variations along the railway track. The irregularities and stiffness variations will produce impact on the switch point. This dynamic force increases significantly with speed. Zhu [28] investigated the effect of varying stiffness below the switch rail of a HSR turnout. Results show that elasticity under the switch rail could effectively improve the vertical wheel and rail interaction dynamics when the train passes from the stock rail to the switch rail.

Wang and Chen, et al. [29, 30] investigated a turnout stiffness smoothing methodology and provided optimal stiffness of rubber pad under rail and fastening components for Chinese HSR turnouts. They recommended that the optimal vertical stiffness of the fastener system be 25 kN/mm for Number 18 turnouts (350 km/h), the stiffness of the rubber pad under rail be $275 \pm 10\%$ kN/mm, and stiffness of the pad under plate be $27 \pm 10\%$ kN/mm.

Dahlberg [31] concluded that using a transition zone to smooth track stiffness can reduce the wheel and rail contact force variation considerably. The optimal stiffness variation in the transition zone (to reduce maximum forces) depends on the traveling direction, but is not very sensitive to it. Also, under-sleeper pads that reduce stiffness variation within the turnout can significantly reduce the wheel and rail contact force variation. The occurrence of hanging sleepers can be reduced by using under-sleeper pads. Because under-sleeper pads distribute the axle load to more sleepers, these pads can also be used to protect the ballast.

5. Components

5.1 Plate Work

The objective of turnout plate work should be to minimize differential settlement without materially changing track stiffness. Multi-tie plates in key areas, such as frogs, have provided longer track surface life for heavy haul applications [13]. Care must be taken to ensure that track stiffness and damping are not radically changed by their presence. Figure 7 shows a multi-tie plate for frog heels.



Figure 7. Multi-Tie Plate for Frog Heels

Plate work should also protect the foundation from high dynamic loading. Elastic pads are widely used in HSR to attenuate the impact on frogs and to smooth the track stiffness.

5.2 Crossties

As is done with rail cant, crossties in turnouts should be configured to match the performance of the track surrounding the turnout. Both timber and concrete can be used successfully. However, concrete ties offer a more economic way to build and maintain track to the tight tolerances needed for high-speed operations. The key to the success of the crosstie is the rail fastening system. Again, it should behave like the surrounding track in terms of deflections, accounting for the higher dynamic loading.

To better support the alignment and surface requirements of high-speed track, it is desirable to have crossties that span both tracks of the turnout heel end. Crosstie linkages between all three tracks are also desirable for the same reason. This configuration does not restrict the designer from having very long crossties spanning the three tracks in a crossover. Long ties connected by steel plates are commonly used in turnouts larger than No. 24 [32].

Recent work to improve the stability of track by using pads between the tie bottom and the ballast has proven effective in extending track surface life. Studies conducted by Austria railroads (OBB) show increases of up to 800 percent in track surfacing cycle intervals [33]. Under heavy axle loads, an increase of 600 percent in track surface life was predicted [34]. Figure 8 shows ties with pads installed. This approach can be applied to turnouts, but is likely to be less effective because of the better railseat pad designs already employed in turnouts.



Figure 8. Cross-ties with Rubber Pads on Bottom Surface

5.3 Switch Throw Mechanisms

As switches lengthen, it is important to have the capability to throw the entire points to maintain the design alignment. This is best done with multiple switch machines or helpers. A hydraulic system with a master switch machine and linked slaves is the preferred system. This system ensures proper alignment throughout the length of the switch.

The ideal location for the switch machine is an issue of some debate. The center of the track is preferred for track dynamics. The traditional arrangement of the machine on head-block ties can create very high dynamic loads for those ties and the machine. This eccentric load and track support may result in cross-level deterioration over time. For maintenance and accessibility, locating the switch machine at least four feet outside the gage of the track is preferred. This allows maintenance to occur without fouling the track.

6. Conclusion

HSR turnout design criteria include unbalanced lateral acceleration or CD, CDCR, and entry and exit jerk. Even though several standards recommend criterion values with ranges, HSR systems in various countries have adopted different design values based on experience and operating conditions.

The design criteria (e.g., one for unbalanced lateral accelerations and jerk) have a direct influence on ride comfort, but cannot be used as performance indices because they only account for kinematic responses, not dynamic responses. In North America, vehicle and turnout dynamic performance must comply with ride comfort and safety standards, such as FRA Track Safety Standards, Part 213. In a worldwide market, vehicle and track performance will also likely comply with ISO 2631.

Switch rail optimization methodologies, such as KGO and rail reprofiling, have demonstrated their effectiveness in reducing wheel and rail force and switch wear through improved axle steering capability. The presteer switch was originally designed for North American low-speed turnouts, and its performance on HSR should be examined.

Track stiffness uniformity along a turnout is critical for HSR operation. Proper track transition and optimal track stiffness can reduce wheel and rail impact forces while improving ride quality.

7. References

1. UIC Leaflet 711. 1981. Geometry of Points and Crossings with UIC Rails Permitting Speeds of 100 km/h or more on the Diverging Track. International Union of Railways, Paris, France.
2. American Railway Engineering and Maintenance-of-Way Association. 2006, *AREMA Manual of Railway Engineering*, Vol. 1, Chapter 5, Track. Lanham, MD.
3. BS EN 13803-2:2006. Railway applications - Track - Track alignment design parameters - Track gauges 1435mm and wider; Part 2: Switches and crossings and comparable alignment with abrupt changes in curvature., European Committee for Standardization, Management Centre: rue de Stassart, 36 B-1050 Brussels.
4. Guo, F., 2006, *High Speed Rail Turnout Design in Foreign Countries*, Chinese Railway, Vol. 2. China Academy of Railway Science, Beijing, China.
5. Peterson, B. et al. 2011. "Adapting Heavy Haul Turnouts for Passenger High Speed Rail Operation," International Heavy Haul Association Conference 2011, Calgary, Canada.
6. Hua-wu, H. 2009, Technical Studies on High-Speed Turnout for China Railways, *Engineering Sciences*, Vol. 11 (5). Chinese Academy of Engineering, Beijing, China
7. Bugarin, M. et al. 2011, Geometry of High Speed Turnouts, Transportation Research Record: *Journal of the Transportation Research Board*, No 2261, National Academies of Sciences and Technology, Washington, DC.
8. Harris, G. 2009. TECHNICAL MEMORANDUM: Turnouts and Station Tracks, TM 2.1.3, California High-Speed Train Project. Parsons Brinckerhoff Inc., New York.
9. UIC Leaflet 703. 1989. Layout Characteristics for Lines Used by Fast Passenger Trains. International Union of Railways, Paris, France.
10. JIS E 1303. 2001. *Railway Turnouts and Crossings*. Japanese Industrial Standard. Japanese Standards Association. Japan.
11. JIS E 1304. 2001. *Dimensions of Turnouts and Crossings*. Japanese Industrial Standard. Japanese Standards Association. Japan.
12. HE Hua-wu. 2007. Research on the Design Theories and Experiments of the 18# Turnout under 250km/h [J]. *Journal of the China Railway Society*, 2007, 29 (1). Beijing, China.
13. Davis, D. et al. 2002. "A Review of Turnout Design Current Practices," Research Report R-961, Association of American Railroads, Transportation Technology Center, Inc., Pueblo, CO.

14. ISO 2631-4. 2001, 2001. Mechanical vibrations and shock-evaluation of human exposure to whole body vibrations. Part 4: Guidelines for the evaluation of the effects of vibration and rotational motion on passenger and crew comfort of fixed guide way transport systems. International Organization for Standardization. Genève, Switzerland.
15. ISO 2631-1. 1997, 1997. Mechanical vibrations and shock-evaluation of human exposure to whole body vibrations. Part 1: General Requirement. International Organization for Standardization. Genève, Switzerland.
16. Garg, V.K., Dukkipati, R.V. 1984. *Dynamics of Railway Vehicle Systems*. Academic Press.
17. Ossberger, H. June, 2005. Successful Introduction of Kinematic Gauge Optimization (KGO) in Heavy Haul Turnouts. *Proceedings of the 8th International Heavy Haul Association (IHHA) Conference*, Rio de Janeiro, Brazil.
18. Otter, D., Davis, D., Gurule, S. December 1996. "Geometry for an Improved Performance No. 20 Turnout," *Technology Digest* TD-96-030, Association of American Railroads, Transportation Technology Center, Inc., Pueblo, CO.
19. Willow, R. 1996. "Compound Point Geometry," Symposium on Turnouts and Special Trackwork, Session 1: Special Trackwork Design and Materials, American Railway Engineering Association, Chicago, IL.
20. Remington, J. 1996. "Tangential Turnout Alignments, a Historical and Practical View," Symposium on Turnouts and Special Trackwork, Session 1: Special Trackwork Design and Materials, American Railway Engineering Association, Chicago, IL.
21. Klauder, L., Chrismer, S., Elkins, J. 2008. "Improved Spiral Geometry for High Speed Rail and Predicted Vehicle Response," *Transportation Research Record*, Vol. 1785, no 1, pp 41–49, National Academies of Sciences, Washington, DC.
22. American Railway Engineering and Maintenance-of-Way Association. 2011. *Manual of Recommended Practices*, Lanham, MD.
23. Shu, X., Davis, D.D. May 2010. "Mainline Switch Design to Improve Vehicle Steering." *Technology Digest* TD-10-013, Association of American Railroads, Transportation Technology Center, Inc., Pueblo, CO.
24. Wu, H., Madrill, B., Davis, D. March 2010. "New Rail Profile Designs for Switch Points." *Technology Digest* TD-10-011, Association of American Railroads, Transportation Technology Center, Inc., Pueblo, CO.
25. Sun, Y.Q., Cole, C., McClanachan, M. June 2009. "Calculation of Wheel Impact Force due to Interaction Between Vehicle and a Turnout," *Proceedings, 9th International Heavy Haul Conference*, International Heavy Haul Association, Shanghai, China.
26. Andersson, C., Dahlberg, T. 1998. Wheel-Rail Impacts at a Railway Turnout Crossing. Proc. Instn Mech Engrs, Part F: *Journal of Rail and Rapid Transit*, Vol. 212 (F2).

27. Andersson, C., Dahlberg, T. 2000. *Load Impacts at Railway Turnout Crossing. Vehicle System Dynamics*, Vol. 33 (Supplement). Taylor & Francis, Dorchester, UK.
28. Zhu, J Y. 2006. On the Effect of Varying Stiffness Under the Switch Rail on the Wheel-Rail Dynamic Characteristics of a High-Speed Turnout. Proc. Instn Mech Engrs, Part F: *Journal of Rail and Rapid Transit*, Vol. 220 (F1). Professional Engineering Publishing,UK.
29. Wang, P., Chen, R. Chen, X. 2010. Characteristics of Track Dynamic Stiffness of Ballastless Turnout in High-Speed Railway, *Proceedings of the 10th International Conference of Chinese Transportation Professionals*. Curran Associates, Inc., New York.
30. Wand, P., Liu, X., Wan, F. 1999. Dynamic Analysis of Space-Coupling System of Train-Turnout with Movable-Nose Frog [J]. *Journal of the China Railway Society*, Vol. 21 (3). Beijing, China.
31. Dahlberg, T. March 2010. Railway Track Stiffness Variations - Consequences and Countermeasures, *International Journal of Civil Engineerng*. Vol. 8, No. 1, Tehran, Iran.
32. Smak, J. January 2010. Amtrak Turnout Design for Improved Reliability, Presentation at Annual Meeting, Transportation Research Board, Washington, DC.
33. Reissberger, K. 2009. Economic analysis of frame ties, Technical University Graz, Graz, Austria.
34. Davis, D., LoPresti, J., Akhtar, M.N. September 2011. "Preliminary Evaluation of Improved Strength Concrete Ties at FAST," *Technology Digest TD-11-034*, Association of American Railroads, Transportation Technology Center, Inc., Pueblo, CO.

Abbreviations and Acronyms

AOA	angle of attack
CD	cant deficiency
CDCR	cant deficiency change rate
FRA	Federal Railroad Administration
HSR	high-speed rail
KGO	Kinematic Gage Optimization
MPF	movable point frog
OBB	Austria railroads
RE	Railway Engineering
rms	root mean square
SBB	Swiss railroads
S&C	switch and crossing
S-C-S	spiral-curve-spiral
S-S	spiral-spiral
SNCF	French national railroad
TTCI	Transportation Technology Center, Inc. (the company)