

LATERAL STABILITY OF BALLAST

BALLAST AND FOUNDATION MATERIALS RESEARCH PROGRAM



SEPTEMBER 1977

Document is available to the public through the
National Technical Information Service,
Springfield, Virginia 22161.

Prepared for
U.S. DEPARTMENT OF TRANSPORTATION
FEDERAL RAILROAD ADMINISTRATION
Office of Research and Development
Washington, D.C. 20590

NOTICE

This document is disseminated under the sponsorship of the Department of Transportation in the interest of information exchange. The United States Government assumes no liability for its contents or use thereof.

1. Report No. FRA/ORD-77/61		2. Government Accession No.		3. Recipient's Catalog No.	
4. Title and Subtitle Lateral Stability of Ballast - Ballast and Foundation Materials Research Program				5. Report Date September 1977	
				6. Performing Organization Code	
7. Author(s) Hay, W. W., Peterson, H. C., Plotkin, D. E., and Bakas, P. T.				8. Performing Organization Report No.	
9. Performing Organization Name and Address Department of Civil Engineering University of Illinois at Urbana-Champaign Urbana, IL 61801				10. Work Unit No.	
				11. Contract or Grant No. DOT-FR-30038	
				13. Type of Report and Period Covered Technical Report	
12. Sponsoring Agency Name and Address Office of Research & Development Federal Railroad Administration, U.S. DOT 2100 2nd Street, S. W. Washington, D. C. 20590				14. Sponsoring Agency Code	
15. Supplementary Notes					
16. Abstract <p>This report presents the results of the lateral stability study of the Ballast and Foundation Materials Research Program. Full-scale lateral stability tests were conducted with a 2-rail, 3-tie system using slag, crushed limestone, and gravel as ballast. Various parameters including Peak Resisting Force and Displacement at Peak Resistance were chosen as possible measures of lateral stability. The results of the study indicate that the differences in the lateral stability behavior of the three ballasts tested is not significant. Also, the results indicate a peak/L/V (lateral resistance/vertical force) ratio of about 0.8.</p>					
17. Key Words Ballast, Ballast Testing, Lateral Stability, Ties, Ballast Shoulder Railroad Track			18. Distribution Statement Document is available to the public through the National Technical Information Service, Springfield, Virginia, 22161		
19. Security Classif. (of this report) Unclassified		20. Security Classif. (of this page) Unclassified		21. No. of Pages 54	22. Price

PREFACE

This report has been generated as part of a sub-contract between the Association of American Railroads Research and Test Department and the University of Illinois.

This sub-contract is part of a larger contract which is a cooperative effort between the Federal Railroad Administration and the Association of American Railroads on improved track structures. The entire program is in response to recognition of the desire for a more durable track structure. To this end, the program is a multi-task effort involving (1) Mathematical modeling to develop equations that describe the behaviour of the track structure under loading, (2) ballast and foundation material research to describe the behaviour of ballast and foundation materials under repeated loads, (3) testing to develop information on the behaviour of the components of the track structure under repeated loads and to validate the mathematical models, and (4) the design of a track research facility in which accelerated service tests can be carried out.

This particular report represents the results of the lateral stability study of the Ballast and Foundation Materials Research Program.

A special note of thanks is given to Mr. William S. Autrey, Chief Engineer, Atchison, Topeka and Santa Fe Railway; Mr. R. M. Brown, Chief Engineer, Union Pacific Railroad; Mr. F. L. Peckover, Railway Geotechnical Consultant; Mr. C. E. Webb, Asst. Vice President, Southern Railway System, as they have served in the capacity of members of the Technical Review Committee for this Ballast and Foundation Materials Research Program; and Dr. R. M. McCafferty as the Contracting Officer's Technical Representative of the FRA on the entire research program.

W. So
Manager and Principal Investigator
Track Structures Research Program
Association of American Railroads

TABLE OF CONTENTS

CHAPTER	Page
Preface	iii
1 INTRODUCTION	1
1.1 General	1
1.2 Purpose and Objectives	2
2 PREVIOUS STUDIES	3
2.1 General	3
2.2 The SNCF Tests	6
3 LATERAL STABILITY TESTS	11
3.1 General	11
3.2 Design and Construction of Test Equipment	13
3.3 Test Performed	19
3.4 Analysis of Lateral Stability of Ballast Materials.	25
4 SUMMARY AND CONCLUSIONS.	41
4.1 Lateral Resistance vs. Ballast Type	41
4.2 Effect of Ballast Shoulder	43
4.3 Observations and Suggestions for Further Tests	44
LIST OF REFERENCES	45

LIST OF TABLES

Table		Page
1	Lateral Stability Test Results	31
2	Lateral Stability Test Results	33
3	Test Result Averages	35

LIST OF FIGURES

Figure		Page
1	Effect of Vertical Force on L/V Ratio	9
2	Load Frame With Track in Test Position	14
3	Load Frame With Track Raised	14
4	Ballast Box and Track Assembly	15
5	Ballast Failure Surface	17
6	Ballast Configurations	24
7	Torpedo Sand: Lateral Force vs Lateral Displacement..	26
8	Number 4 BOF Steel Slag: Lateral Force vs Lateral Displacement	27
9	Number 4 Crushed Limestone: Lateral Force vs Lateral Displacement	28
10	Number 4 Gravel: Lateral Force vs Lateral Displace- ment	29
11	Average Force vs Displacement Curves For Loaded 3-Tie Tests.	36

CHAPTER 1

INTRODUCTION

1.1 GENERAL

Railroad track must be restrained from moving horizontally on the roadbed. Poorly aligned track greatly increases roughness of ride, "hunting" of trucks, sway of cars, wheel-rail forces, and danger of rail overturning or the wheel climbing the rail. In the extreme case of lateral track movement, the track can slide off its ballast bed and derail the train. In general these effects increase with the speed of the train.

The Federal Railroad Administration includes alignment in its Track Safety Standards, ranging from five inches (12.7 cm) deviation of the mid-offset from a 62-foot (18.9 m) line for Class 1 track (10 miles per hour (16.1 km/h) maximum for freight, 15 miles per hour (24.1 mn/h) for passenger) to one-half inch (1.27 cm) deviation on tangent track and three-eighths inch (0.95 cm) deviation on curves for Class 6 track (110 miles per hour (117 km/h) maximum for all trains.)¹

Lateral motion can be caused by expansion of continuous welded rail (sun kinks). It can also occur under a moving train due to centrifugal reaction on curves, or forces caused by a train "running in" under heavy braking, reconnecting after train separation,² or entering heavy grades or curves.

Lateral resistance is provided by the rails and the frictional resistance between the bottom and sides of the tie and the ballast. Rail, because of its stiffness, resists lateral load and also transfers the lateral load to many ties.³ The frictional resistance that can develop between the tie surface and the ballast is dependent on the condition of the ballast aggregate matrix. The

Superscripts refer to reference numbers.

technique used for ballast compaction thus plays an important role in the development of frictional resistance between ties and ballast.

Presently, there is not much information available to differentiate between lateral track resistance using concrete and wood ties. The use of heavier concrete ties with larger surface areas seems attractive for lateral stability considerations; however, the abrasive action between the concrete tie surface and ballast particles needs further investigation.

1.2 PURPOSE AND OBJECTIVES

The studies on lateral stability detailed in this report are a part of the Federal Railroad Administration-Association of American Railroads Ballast and Foundation Materials Research Program. The purpose of this phase of the program was to obtain relative or comparative measures of lateral stability of some common ballast materials. Measurements were made under various loads and ballast configurations. In addition, the effect of a shoulder, beyond the tie end, was also investigated.

CHAPTER 2

PREVIOUS STUDIES

2.1 GENERAL

Broad-based field experience has suggested that lateral stability depends on the ballast at the tie ends, the size and shape of the ballast shoulders, and ballast-tie friction. Ballast-tie friction has been considered to be a function of type of wood, tie size and shape, type and particle size and shape of the ballast, load on the tie, degree of tamping, and presence of moisture or foreign material. Disturbance of seasoned ballast reduces lateral strength;⁴ freshly-worked ballast loses lateral restraint to as low as 52 percent of compacted strength.⁵

There is disagreement as to the restraint provided by the ballast shoulder. Some railroads use a minimal amount of ballast at the ends of the ties, while some European railroads use an elevated ballast shoulder.

The British Transport Commission had determined that laboratory tests gave comparable lateral restraint values to in-situ tests using six-tie track sections,⁶ and studies of lateral restraint of concrete ties in Japan used at least four ties.⁷ Track loading studies by G. M. Magee to compare settlement and lateral restraint of polymer-stabilized ballast with a plain ballast bed used two ties.^{8, 9, 10} Dr. Raymond's Canadian ballast studies use an eleven-tie track section.¹¹ Proposed studies at Delft University in the Netherlands include "full-scale track structures" although the exact number of ties was not specified.¹² A nine-tie section of track was used for in-situ lateral stability tests in France,¹³ and the AAR Oscillator test used a 39-foot (11.9 m) long track with 20-inch (50.8 cm) tie spacing.¹⁴

The 1972 AREA ballast test proposal specified a minimum track length of six feet (1.83 m).¹⁵ Tests of ballast pressure distribution done at the University of Illinois in 1919 by Prof. A. N. Talbot,¹⁶ and more recent tests conducted in 1966 by Salem and Hay,^{17, 18} used three-tie track sections. Thus, it became evident that ballast tests, in general, used two or more ties. No studies could be found that related single-tie to multiple-tie tests.

In the early seventies, field performance tests were carried out by the Chessie System, Inc. to determine the capabilities of concrete ties under heavy main line service. One aspect of the tests involved lateral track resistance field test of concrete ties and wood ties at Sabot, Virginia²⁸. The lateral tests were carried out in two phases on ten individual 39-foot (11.9 m) long track panels. The results of the Sabot tests are summarized below.

1. There is not much difference in lateral track resistance between concrete and wood tie tracks.
2. Tamping could weaken lateral track resistance materially, as much as 60%.
3. Mechanical compaction measurably increases lateral resistance on freshly tamped track.
4. The effect of about 5 MGT traffic is equivalent to mechanical ballast compaction.

Track resistance values obtained as a function of panel preparation exhibited a wide range. Ultimate lateral resistance (average for all panels) and lateral displacement at 12,000 lbf (53.76 kN) as a function of track condition were as follows:

<u>Track Condition</u>	<u>Yield Force (lbs.)</u>	<u>Displacement at 12,000 lbs. Force, in.</u>
Settled (180 MGT)	35,000*	0.05
Trafficked (7 MGT)	17,000	0.13
Mechanically Compacted	16,000	0.23
Freshly Tamped	14,000	0.94

*estimate

The Sabot tests indicated that the application of ballast compaction was promising for reduction of lateral track displacement when compared with that obtained after tamping.²⁸

Field testing for lateral stability is being carried out at the Facility for Accelerated Service Testing (FAST), located at the Transportation Test Center of the U. S. Department of Transportation near Pueblo, Colorado. The FAST program is jointly funded by the Federal Railroad Administration and the Association of American Railroads.

2.2 THE SNCF TESTS

In the early 1950's, extensive tests were carried out by the French National Railways (SNCF) to investigate lateral resistance characteristics of track.^{13, 19} All tests were performed on "well maintained" sections and fell into two major categories: those with both lateral and vertical loads applied by a moving "track shifting vehicle", and static tests similar to those performed at the University of Illinois. One of the basic measurements obtained was the L/V ratio. This is defined as the ratio of lateral force to vertical force on rail required to initiate permanent (non-elastic) lateral displacement of the track. The L/V ratio is specified for a given or small range of vertical forces.

The first set of tests was performed with the moving track shifting vehicle. This car displaced the track laterally by means of a center axle which applied vertical loads ranging from 12,500 to 26,700 pounds (5,600 to 12,260 kg). The lateral load required to cause displacement was then measured as a percentage of the vertical load. The majority of L/V ratios were measured at a vertical load of 12,500 pounds (5,600 kg), and in reporting the tests, the "scattering" of the results was said to be "slight" over 1,000 trials.

The findings for the first set of tests include the following:

1. Concrete ties show much greater lateral stability than wood ties.
2. Track joints did not appear to displace any easier than center sections.
3. Under certain conditions, permanent displacement could be induced at an L/V as low as 0.4, and wheel flange climbing the rail took place at an L/V of nearly 1.5. (Recent tests made by Southern Railway on track with 132 pound (60 kg) rail found rail rollover

to occur at an L/V of 0.64, and wheel climb at an L/V of 1.29).²⁰

4. The continuity and size of the rails play an important part in resisting lateral movement. On track with wooden ties and 110 pound (50 kg) rail, L/V was found to be 0.86, while on another section of nearly identical track, only with 136 pound (62 kg) rail L/V was measured at 1.15.
5. The force/displacement curve closely resembled that of a standard tensile test of a steel bar, but in the case of ballast, the peak resistance occurred just past the "yield point". Therefore, once a lateral force great enough to cause permanent displacement has been applied to the track, continued application of such a force will cause large displacements.
6. The greater the vertical load, the more L/V diminishes.
7. The upper limit of elastic displacement is on the order of 1/8" (3.2 mm).
8. "The resistance of the track to transverse movement being only due to friction, it is useful to bear in mind that this friction is considerably reduced by vibration, especially if the ballast includes elements of very small dimensions and is apt to be dirty." But while clean ballast is important in maintaining lateral stability, track maintenance or other disturbances of the ballast section cause significant reductions in lateral stability.
9. A certain small degree of lateral resilience helps reduce or dampen lateral oscillations, and therefore improves riding qualities.

The second set of tests was performed on sections of track, about 15 feet (4.57 m) long, which had been separated from the existing main lines by cutting out a small length of rail. These sections were then pulled laterally with no vertical load. For the most part, sections were chosen on stable track which had not had any maintenance operations in several months.

The findings for the second set of tests include the following:

1. The variations (in the tests) were remarkably small.
2. The type and shape of ties were important factors.
3. The type of ballast and its age are of negligible importance.

However, within the range of ballast types, slag was found to be best with gravel having the lowest stability.

4. Small disturbances to the track (for example, a simple lateral shift of the track to rectify the alignment) can significantly reduce its lateral stability.
5. Heavy tie renewals or reballasting causes track to lose 25 to 30 percent of its lateral stability and several days to several weeks are required before the track regains its former level of lateral stability.

In the SNCF tests the shape of the force/displacement curves was very similar for all ballast types. These curves showed the peak, or ultimate resisting force, to be less than 10 percent higher than the yield force. Therefore, once the limit of elastic displacement has been passed, there is little "reserve" strength remaining.

Many test results have been expressed in terms of the L/V ratio, and the impression may be given that this term is a constant. It is not constant, but depends on the magnitude of the vertical load. Figure 1 shows how L/V varied in the SNCF tests on track with wood ties.

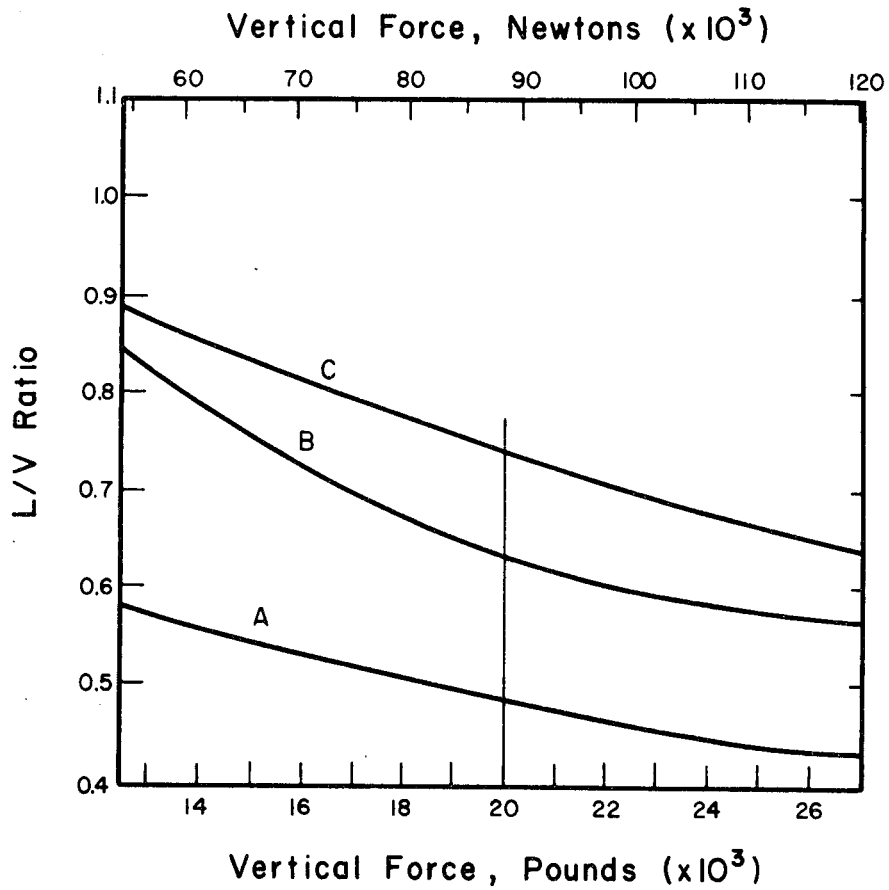

- A: 101 lb (46 kg) Rail On Wood Ties With No Tie Plates.
B: 110 lb (50 kg) Rail On Wood Ties With Tie Plates.
C: 110 lb (50 kg) Rail On Wood Ties With Tie Plates And Clip Fastenings.

Figure 1. Effect of Vertical Force on L/V Ratio

As shown, the L/V ratios are beginning to level off near the maximum vertical load of 26,700 pounds (120.12 kN), but still cannot be considered constant. In the U. S. axle loads may be commonly found up to 65,000 pounds (29,500 kg), about two times higher than the maximum vertical loads used in the SNCF tests. Therefore, the resulting L/V ratios may not fully apply to current U. S. conditions.

CHAPTER 3

LATERAL STABILITY TESTS

3.1 GENERAL

At first, consideration was given to devising a lateral restraint test which might also fit all the criteria for use by railroad laboratories, suggested by Goldbeck and committee:²¹

1. It should be a measure of the resistance of the ballast to displacement when subjected to load.
2. It should be reproducible.
3. It should be relatively simple to perform.
4. The sample should not be unduly large.

It was thought that a large-scale shear box might meet the above criteria while providing some measure of restraint of the ballast under various loading conditions. But, as many track men have observed, the ties often move through the ballast with little if any motion of ballast particles under failure conditions. Thus the interactions of the ties with the ballast and the action of ballast shoulders become important in any lateral stability study. Therefore, a full-scale track and ballast section seemed most appropriate for testing.

One important question was whether to use one or more ties. Although a single-tie test was considered, this would not provide the same boundary conditions as in track. A single tie would not simulate the effects of pressure overlap within the ballast section caused by adjacent ties; effects and motion of crib ballast would not be accurately determined. As in past University of Illinois tests,¹⁷ a three tie test section was selected. All three ties could be loaded and pulled, or just the center tie could be pulled, with the two

outside ties providing prototypical boundary conditions.

One-tie tests were expected to compare fairly well with multiple-tie tests. Analysis conducted for multiple ties based on Talbot's line-of-pressure diagrams showed 10 percent of the applied tie pressure at a depth of 12 inches (30.5 cm), between the ties.¹⁶ Calculations following Ireland's analysis,²² based on Newmark's solution for foundation subgrade stresses, showed 4 percent of applied pressure (at the surface) between ties at 12 inches (30.5 cm) depth for a 20 in. (50.8 cm) tie spacing. Clarke's diagrams of pressure distributions, based on works of Talbot and Zimmerman, gave similar results.⁴ Thus any pressure overlap between ties was expected to be small. The major effect expected with three ties was increased resistance over that of a single tie due to crib ballast friction and tie-end ballast.

3.2 DESIGN AND CONSTRUCTION OF TEST EQUIPMENT

The Civil Engineering Laboratory made three 25,000 pound (111 kN) electrohydraulic rams available, along with the necessary pumps, control equipment, electronic load-function generators, amplifiers, and an automatic x-y plotter. The equipment included load cells and displacement transducers which allowed outputs and feedback control proportional to either force or displacement. Thus tests could be run at predetermined constant loads, cyclic loading, cyclic displacement, or rate of displacement. Two of the rams, one loading each rail vertically, were used to simulate a 50,000-pound (222 kN) axle load (25,000 pounds (111 kN) per ram) with loads applied in selected wave patterns as rapidly as 10 cycles per second. The third ram supplied horizontal force and standard bolt-together structural members were used to construct a load frame. This equipment made possible the controlled application of forces to the track section and ballast under test, and the measurement of the responses to these forces. (See Figures 2 and 3).

A ballast box to contain and support the ballast section was constructed with dimensions selected to fit the loading frame and still contain the largest ballast section to be tested (See Figure 4). A 4-inch (10.2 cm) thick concrete slab was cast in place inside this box. The surface was roughened, and Number 4 crushed limestone ballast was pressed into the surface of the fresh concrete. This was done to eliminate effects of ballast-subgrade interaction and study only ballast restraint. This type of "subgrade" was expected to cause increased inter-particle forces and stiffness, compared to a softer subgrade, as predicted by Meacham and Ahlbeck in their computer study.²³ However, it was felt that even with an actual subgrade, laboratory values would differ from field values due to other factors such as moisture content, amount

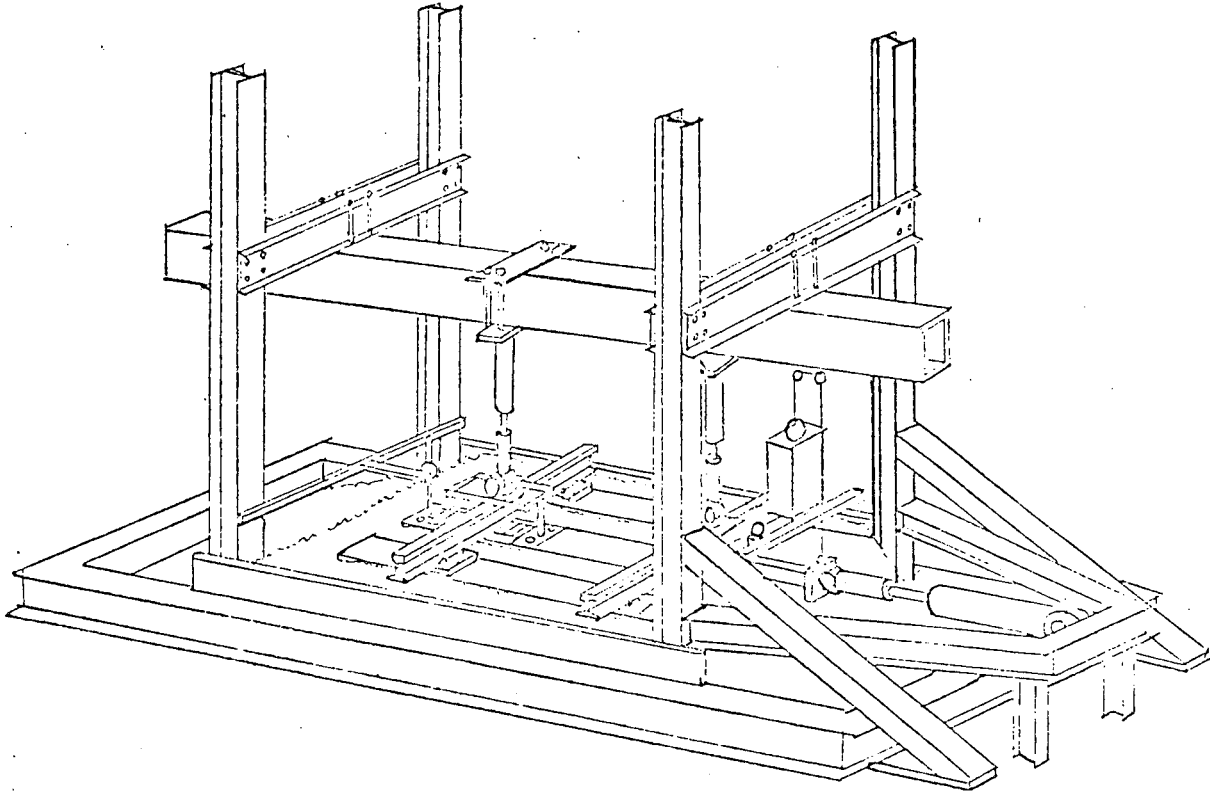

Figure 2. Load Frame with Track in Test Position

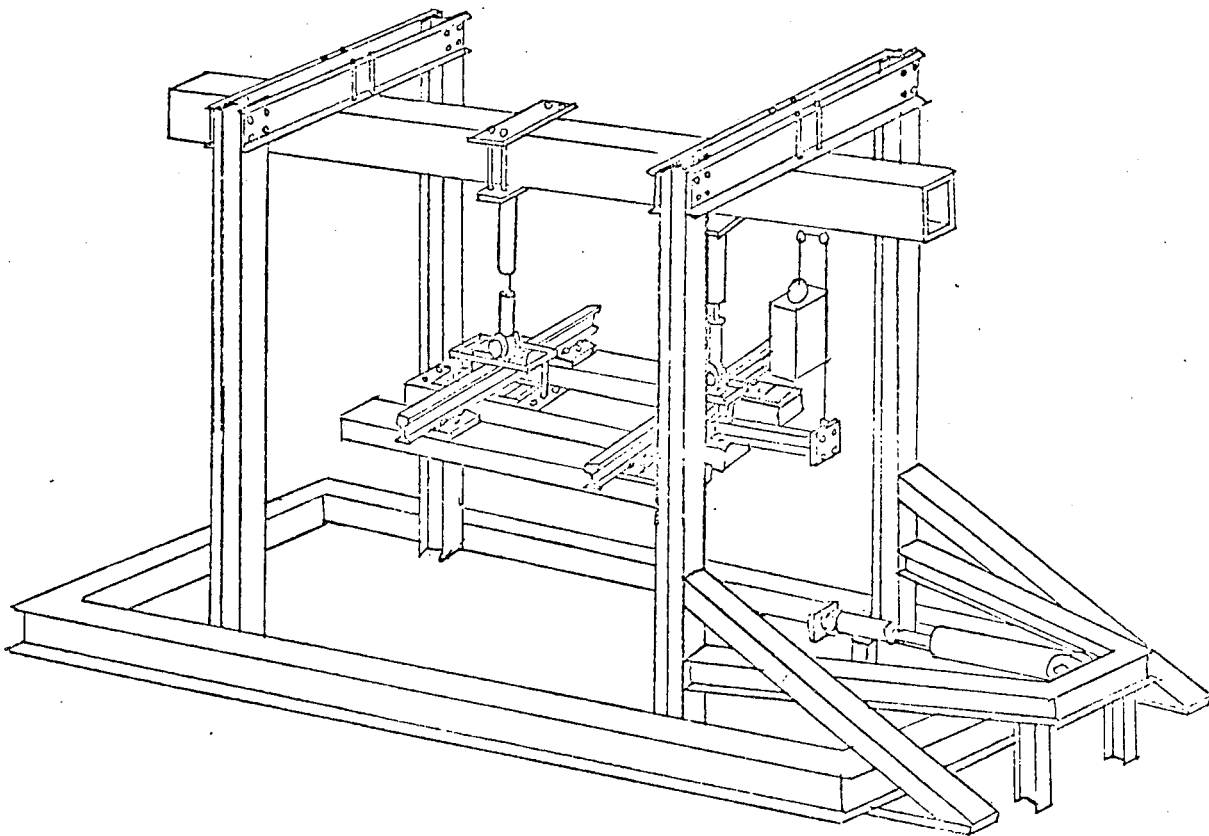

Figure 3. Load Frame with Track Raised

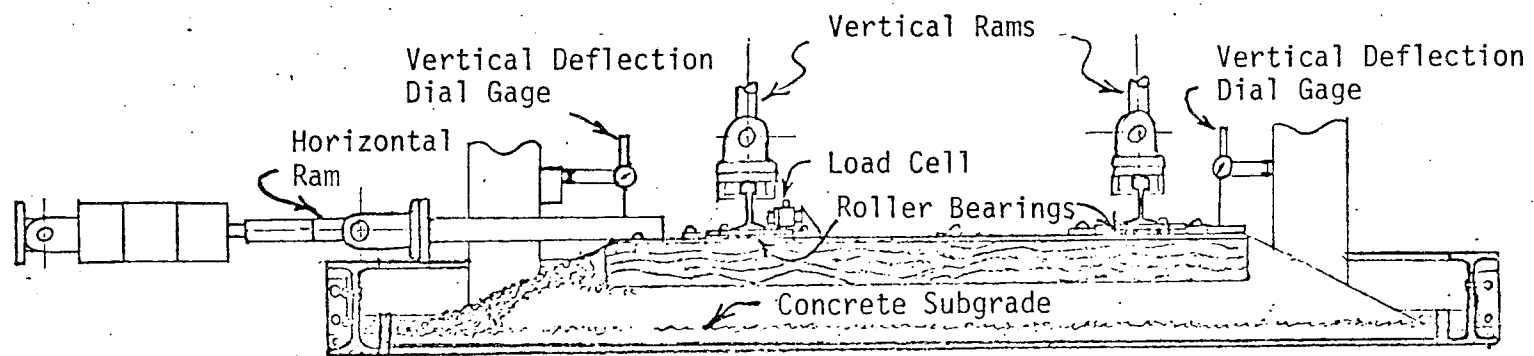
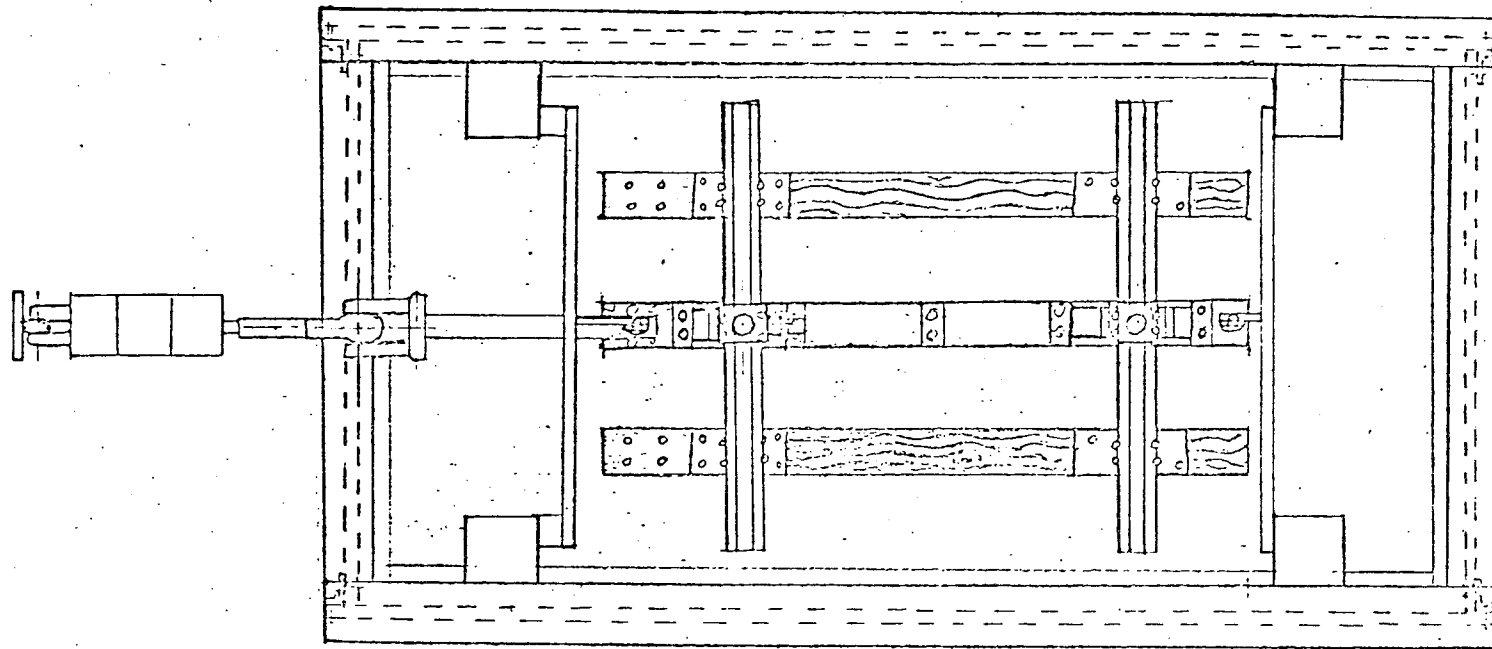

Figure 4. Ballast Box and Track Assembly

of fines, degree of compaction, and different subgrade conditions. These differences would preclude the assignment of any absolute stability values, but not a valid comparison among the different ballasts.

Consideration was given to the minimum depth of ballast. It should be deep enough to include all gross interparticle motions, both under the ties and in the shoulders. Preliminary visual observation of particle motion in a quarter-scale Plexiglas penetration box showed the maximum depth of disturbance beneath the tie to be $1/3$ times the tie height. (See Figure 5). Selecting 12 inches (30.5 cm) as the ballast depth below the tie, as specified by many railroads, the maximum depth of disturbance beneath the ties would be 2.3 inches (5.6 cm). Thus sufficient depth would be provided for any effects of large particle movements.

To examine the effects of shoulders, it was decided to test different shoulder widths for lateral stability under various axle loads. The effects of compacted shoulders, as recommended in Canada,²⁴ and the United States,²⁵ were also considered for seating the track section.

A well-weathered track section in good condition, consisting of two 6-foot (1.83 m) long 132-pound (60 kg) RE rails on double shouldered tie plates mounted on three 8-foot 6-inch (2.59 m) Number 5 (9 inches 22.9 cm) wide by 7 inches (17.8 cm) high) used creosote-treated hardwood ties, was used for the tests. With the weathering it had received, this section was fairly typical of good track which has been in place for some time. Ties were spaced at 21 inches (0.53 m) center-to-center, with the two outer ties box-anchored with rail anchors.

The lower swivels of the vertical load rams were clamped to the centers of the rails over the center tie, to simulate an axle load directly over this tie. (See Figure 4).

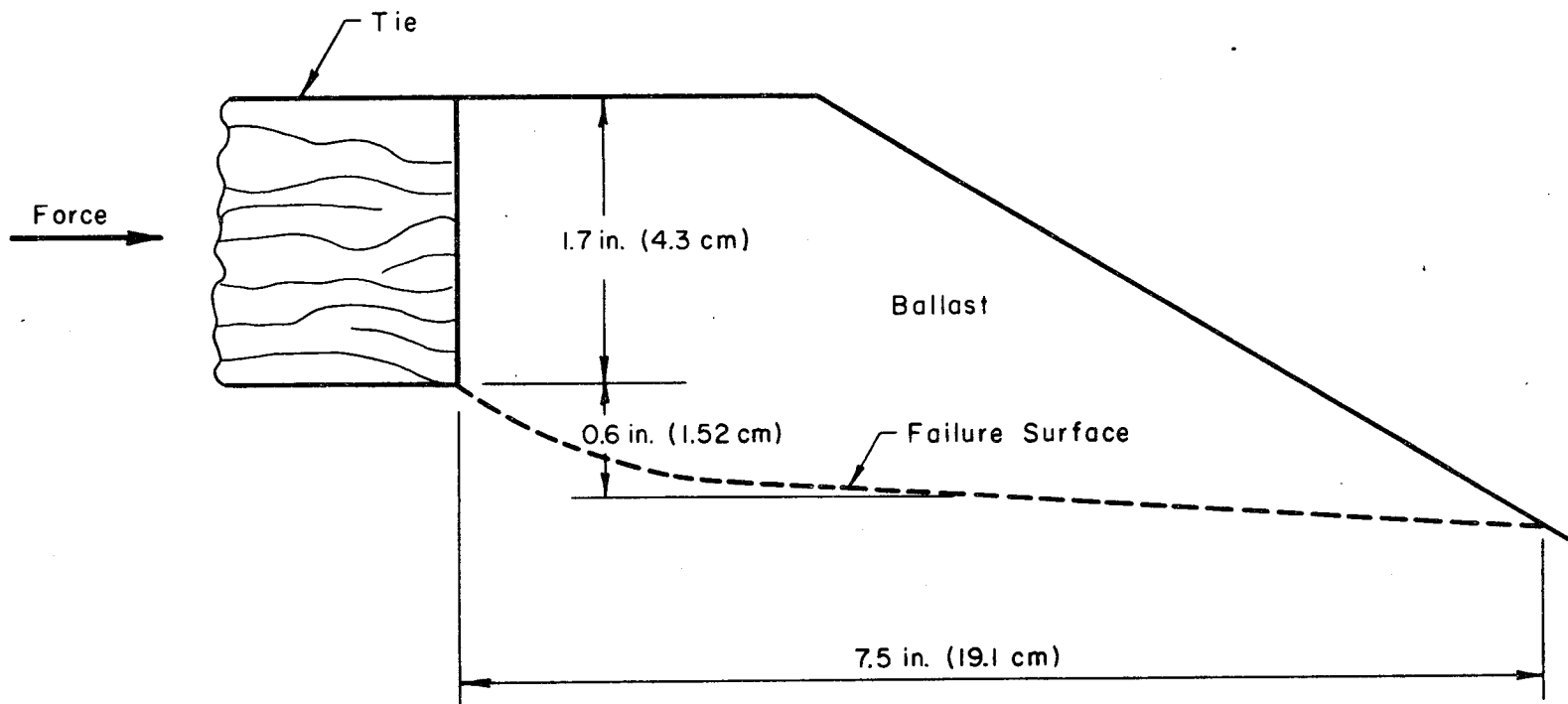

Figure 5. Ballast Failure Surface

Roller-bearing tie plates were obtained from the AAR research laboratory in Chicago. These allowed the center tie to move in relation to the rails. A 3/8 inch (0.95 cm) steel plate was spiked and lag-bolted to the top of the center tie to replace the lower race of the roller bearings (giving much greater travel by allowing the use of two roller sets per rail), and to transmit horizontal forces evenly along the top of the tie. (Unfortunately, this plate bent elastically when the ram pushed with a force exceeding 7500 pounds (33.4 kN) although it performed flawlessly at all loads in the pull mode. For this reason all tests, except 500 pounds (22.3 kN) oscillation and a few unloaded rapid pushbacks, were operated with the horizontal ram pulling the ties.

3.3 TESTS PERFORMED

Preparation

Ballast was placed in the ballast box in two 6-inch (15.2 cm) lifts. Each was compacted under the outer 34 inches (86.4 cm) of the ties plus 6 inches (15.2 cm) beyond the tie ends in accordance with preferred railroad practice. This was done with 5 passes of a gasoline powered plate compactor rated at 1700 pounds (7.57 kN) impact at 5000 RPM.

The rail-tie assembly was then lowered to the prepared ballast bed, and the test ballast section was formed and tamped. Shovel tamping was used for the tests with sand, while standard hand tamping irons were used with coarser ballast materials.

Each test was preceded by a seating process to simulate trains running over the track. An inverted haversine loading by the vertical rams, operating simultaneously at 5 load cycles per second downward, produced a loading pattern similar to (but more regular than) the pattern imposed on track by a moving train. Maximum force of the two rams simulated a 50,000 pound (223 kN) axle load.

It was decided that seating with 450,000 gross tons (4.1×10^8 kg), approximately equivalent to 90 fifty-car trains, would produce a uniformly compacted test roadbed. This was a reasonable average between the practice of some railroads which lift speed restrictions almost immediately after tamping operations, and the requirement of about 1,000,000 gross tons (9.1×10^8 kg) of traffic to gain maximum lateral resistance.²⁴

Eighteen thousand cycles gave 90 "trains" in one hour at 5 cycles per second:

5 per second x 3600 seconds per hour = 18,000 cycles

90 trains x 50 cars x 4 axles per car = 18,000 cycles

18,000 cycles x 25 tons per cycle = 450,000 gross tons (4.1×10^8 kg)

Simulated speed was 42.6 miles per hour (68.5 km/h):

(50 feet per car/4 axles per car) x (18,000 axles per hour/5280 feet per mile) = 42.6 miles per hour (68.5 km/h)

The ties were reseated in the ballast bed before each test.

Both before and after seating, compaction was estimated by measuring vertical depression of the center tie under steady vertical applied loads ranging from zero to 50,000 pounds (223 kN), measured at 10,000-pound (144.5 kN) increments. This was thought to be as suitable for this test as the method of excavating and weighing compacted ballast, then measuring the volume by pouring water into the membrane-lined hole from which the ballast had been excavated, as used by the British in their tests.²⁶ Sophisticated compaction measurements using sound, radio waves, gamma radiation, or electromechanical means, as described by Nemkova,²⁷ were deemed to be unnecessary.

Test Procedure

Five types of tests were selected. Each test was preceded by 18,000 cycles of load for seating.

1. With the load cell between the center tie and the first rail, as described previously, all three ties were pulled at three different rates of displacement (0.075 inches (1.9 mm) per minute, 0.75 inches (1.9 cm) per minute, and a rapid rate estimated to exceed 1 inch (2.54 cm) per second).

Various vertical loads were applied. The x-y plotter recorded horizontal force vs horizontal displacement, and vertical displacements of each end of the center tie were read from the four-inch-travel dial gages.

2. The center tie was loaded vertically and pulled laterally with the ballast dug out from underneath the two outer ties. Thus, these outer ties were prevented from taking any of the applied vertical load, but still provided lateral support for the crib ballast. Except for testing a single tie, the test was identical to Number 1. (Digging out the ballast under the outside ties caused the ballast section to lose longitudinal stability during seating. Chain restraints, added during seating, helped maintain the position of the track in the ballast bed.)

3. The center tie was loaded vertically with a 50,000 pound (223 kN) load and oscillated horizontally in a sine wave pattern at a peak force of 5000 pounds (22.3 kN), 10,000 pounds (44.5 kN) peak-to-peak with a frequency of 2 cycles per second. Twenty-five minutes of oscillation gave 3000 cycles.

The main test program for gravel, crushed limestone, and slag consisted of tests one, two, and three under various loads and ballast configurations.

1. Vertical Loads

- A. Weight of center tie only (rails and outer ties lifted by vertical rams).
- B. Ballast dug out from underneath outer ties, with total weight of track and swivels resting on center tie for single-tie tests, but no hydraulic loading. This simulates poor track conditions, with hanging ties on either side of a

loaded tie. Track and ram weight with no hydraulic loading for three-tie tests. This was called "zero pounds load".

- C. 20,000 pound (87 kN) vertical load.
- D. 50,000 pound (223 kN) vertical load was tried, but lateral restraint exceeded the 25,000 pound (112 kN) capability of the horizontal ram in most cases. Therefore, the 50,000 pound (223 kN) vertical load lateral-pull tests were dropped from the program.

II. Rates of Horizontal Displacement

- A. The normal rate was 0.075 inches (1.9 mm) per minute, requiring 33.3 minutes for 2.5 inches (6.35 cm) of displacement.
- B. The rapid rate was 0.75 inches (1.9 cm) per minute, requiring only 3.3 minutes per 2.5 inches (6.35 cm) of displacement. As this was too rapid to permit vertical depression to be read from the dial gages, "rapid" tests were run only for comparisons with slow tests to examine the effects of the rate of motion on lateral restraint.
- C. The "quick" rate was estimated to exceed 1 inch (2.54 cm) per second, and was used for visual observations only.

III. Ballast Configurations (See Figure 6)

- A. No Crib or End Ballast: ties rest on ballast surface with no crib or end ballast above tie bottom.
- B. No End Ballast: crib ballast between ties, but none at tie ends.

- C. 0-Inch Shoulder: full crib between ties, with ballast at a 2:1 slope from top of tie ends.
- D. 6-Inch Shoulder: standard AAR 6-Inch (15.2 cm) shoulder ballast section; shoulders not compacted.
- E. 12-Inch Shoulder: standard AAR 12-Inch (30.5 cm) shoulder ballast section; shoulders not compacted.

IV. Ballast Materials Tested

- A. Torpedo Sand (used for setting up test runs and adjusting equipment). Torpedo sand is a type of coarse sand used in concrete construction.
- B. AREA Number 4 gradation BOF steel slag
- C. AREA Number 4 gradation crushed limestone
- D. AREA Number 4 gradation gravel

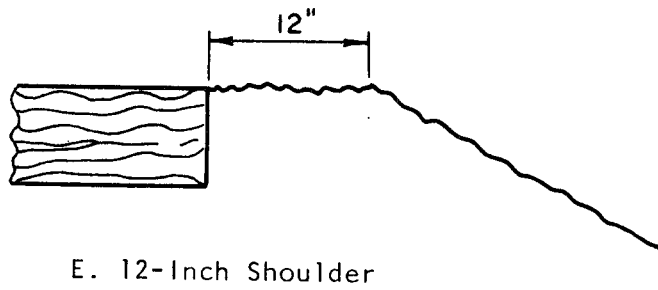
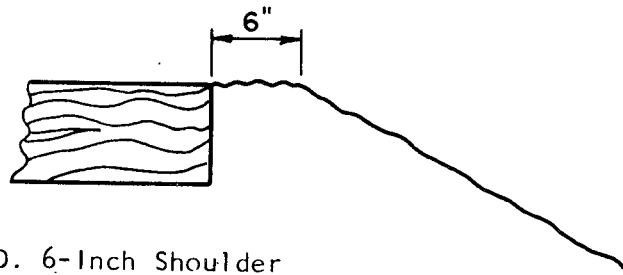
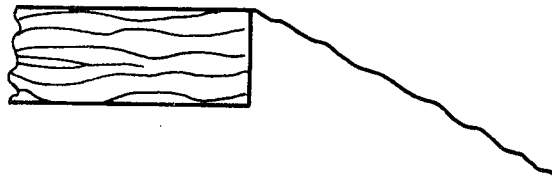
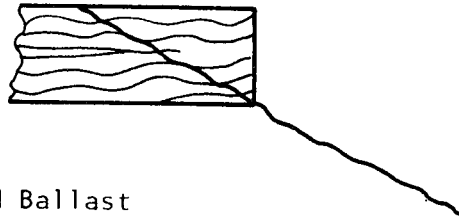
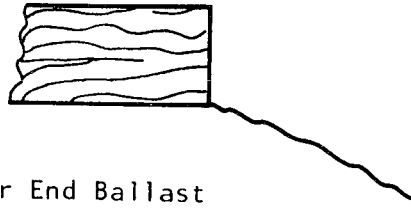

Figure 6. Ballast Configurations

3.4 ANALYSIS OF LATERAL STABILITY OF BALLAST MATERIALS

Before lateral stability of a tie can be analyzed it should be clear what the term "lateral stability" means. Let it be defined as resistance to movement of a tie in the direction parallel to the tie length.

In order to make a complete analysis, both factors - resistance (resisting force) and movement (displacement, both elastic and permanent) must be considered. Upon examination of the test curves, (Figures 7, 8, 9 and 10) the following parameters were chosen as possible measures of lateral stability:

1. Peak Resisting Force
2. Displacement at Peak Resistance
3. Yield Force
4. Displacement at Yield
5. Yield Force as a Percentage of Peak Resisting Force
6. Slope of Initial Part of Curve
7. Resistance at 0.1" (2.54 mm) and 0.25" (6.35 mm) Displacement
8. Resistance with Zero Vertical Load, and Corresponding Displacements

These parameters were used in an attempt to measure the level of, as well as the differences in, the stability provided by different ballast materials, and to evaluate the effect of different shoulder widths. Data obtained using samples of steel slag, crushed limestone, and gravel was compared.

More weight was given to the 3-tie tests than the 1-tie tests. Due to time and economic limitations, the 1-tie tests tended to vary; only two were performed with slag, while five were performed with limestone. Of the two with slag, the 1C test had irregularities which make values for

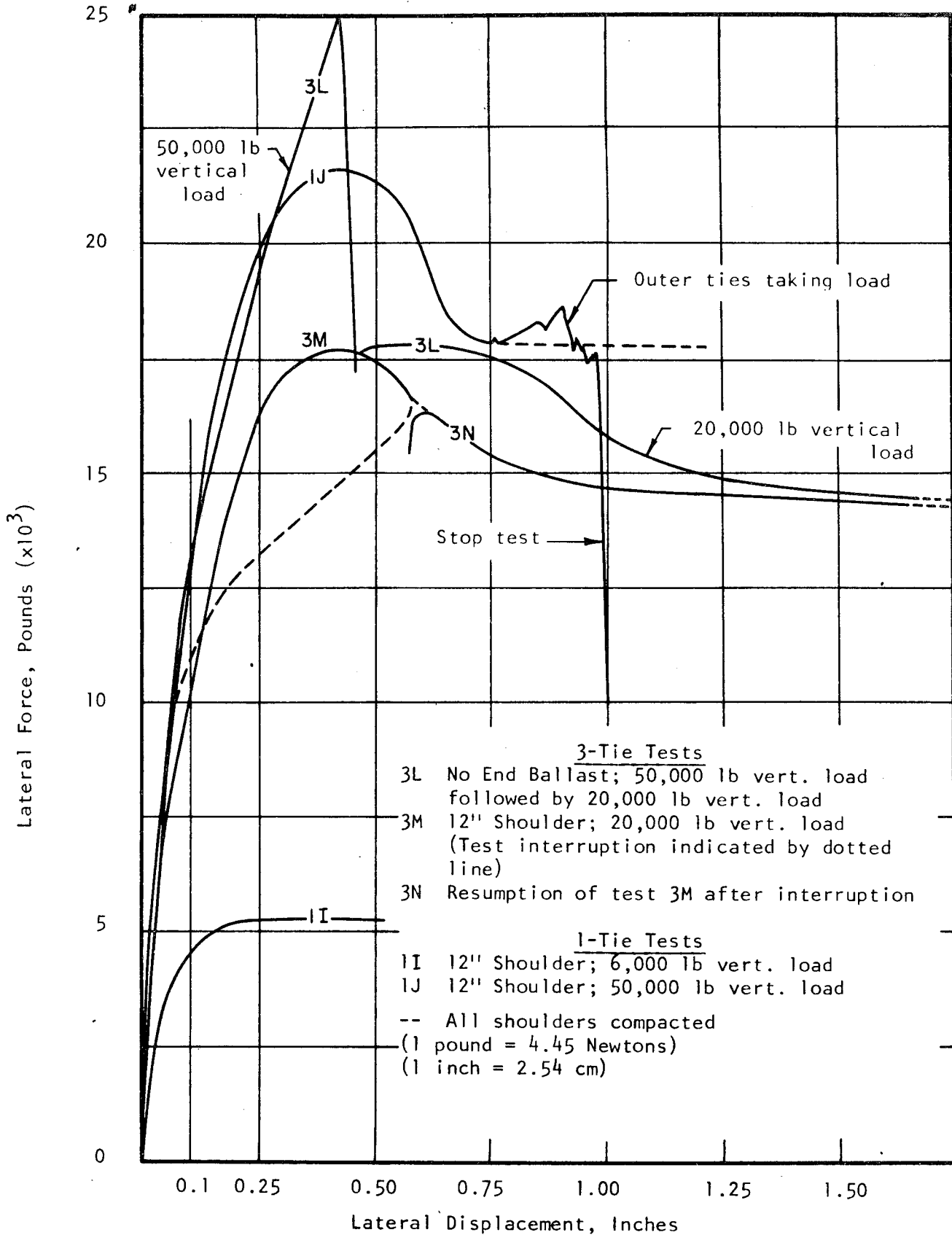

Figure 7. Torpedo Sand: Lateral Force vs Lateral Displacement

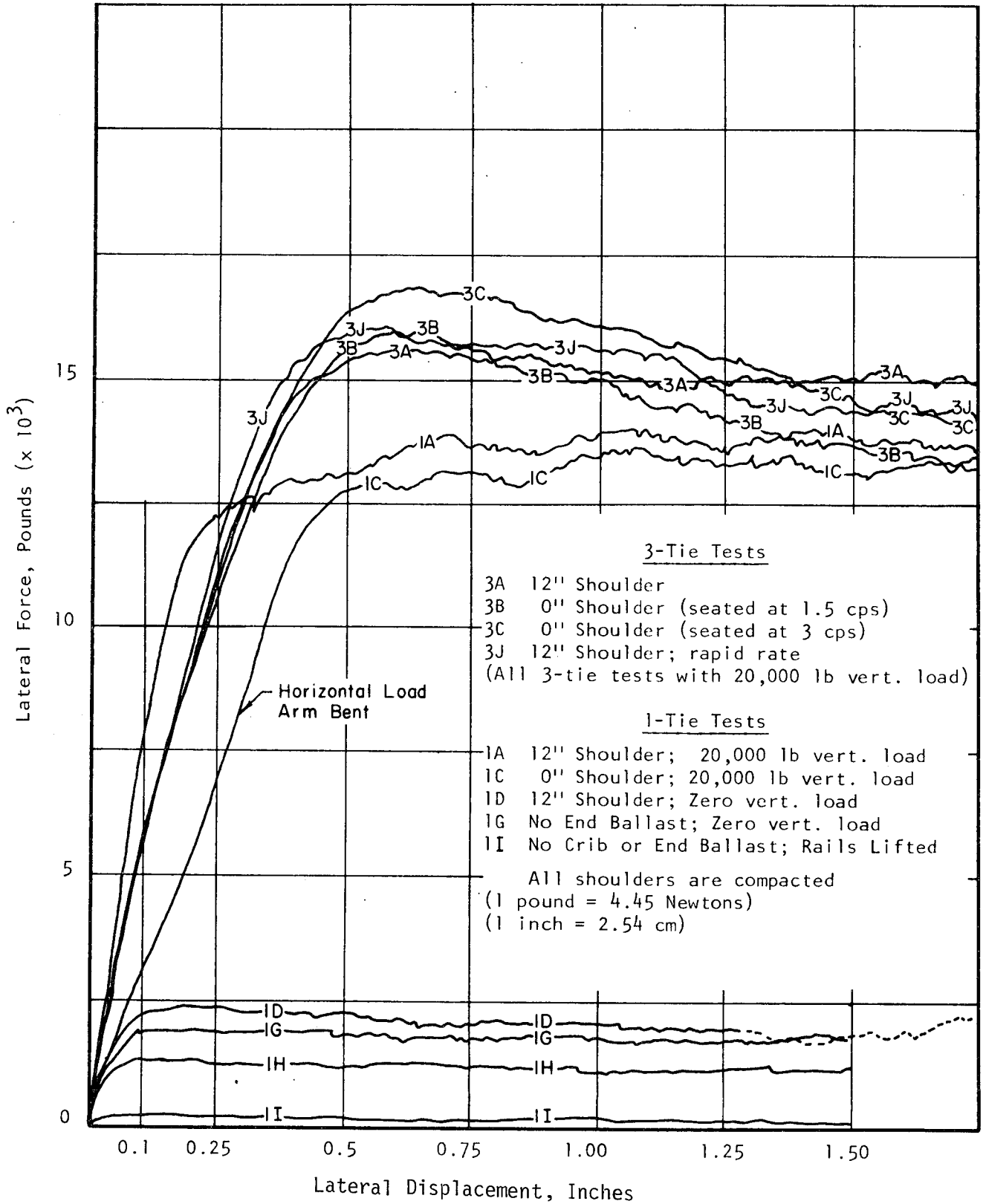

Figure 8. Number 4 BOF Steel Slag: Lateral Force vs Lateral Displacement

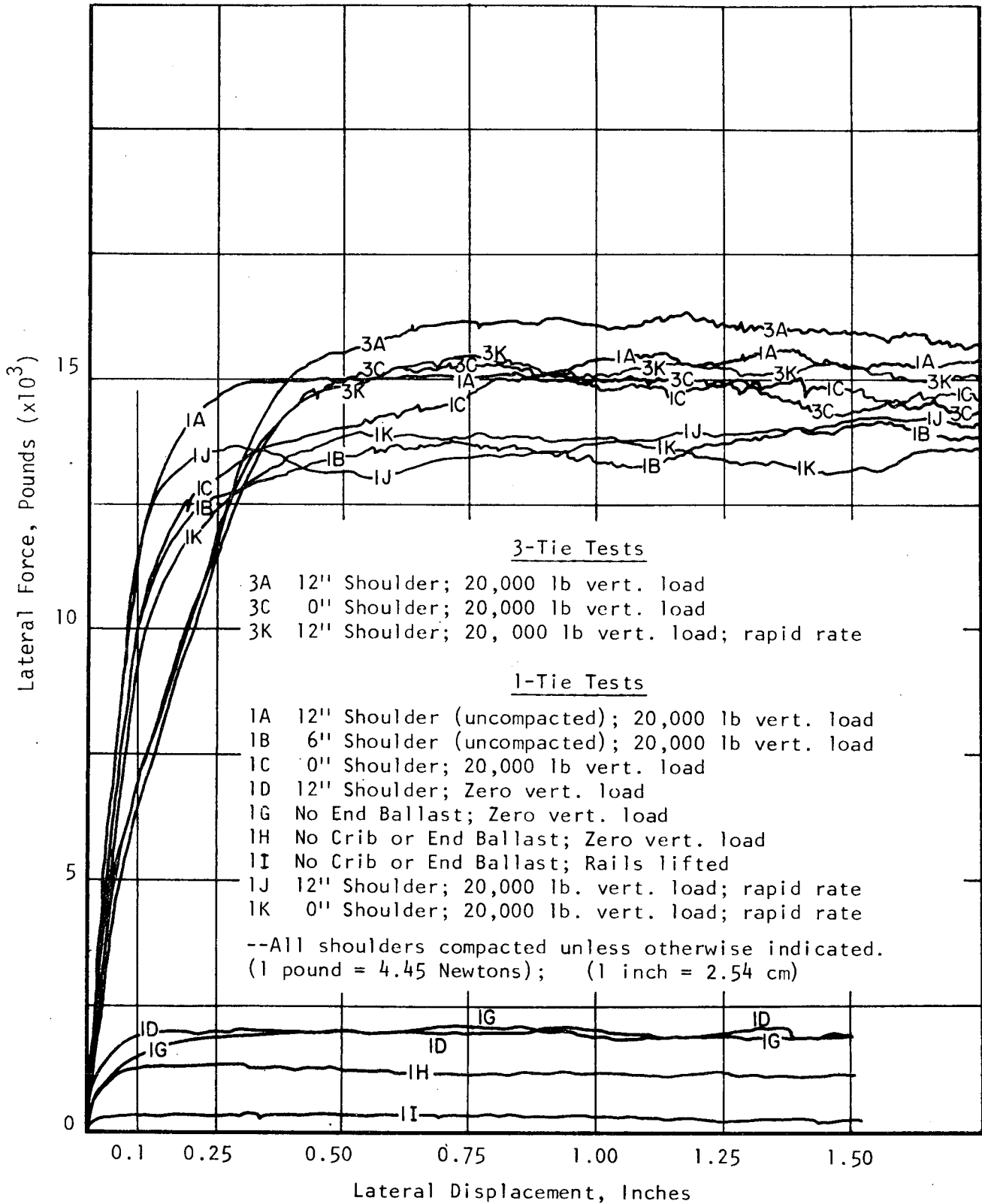

Figure 9. Number 4 Crushed Limestone: Lateral Force vs Lateral Displacement

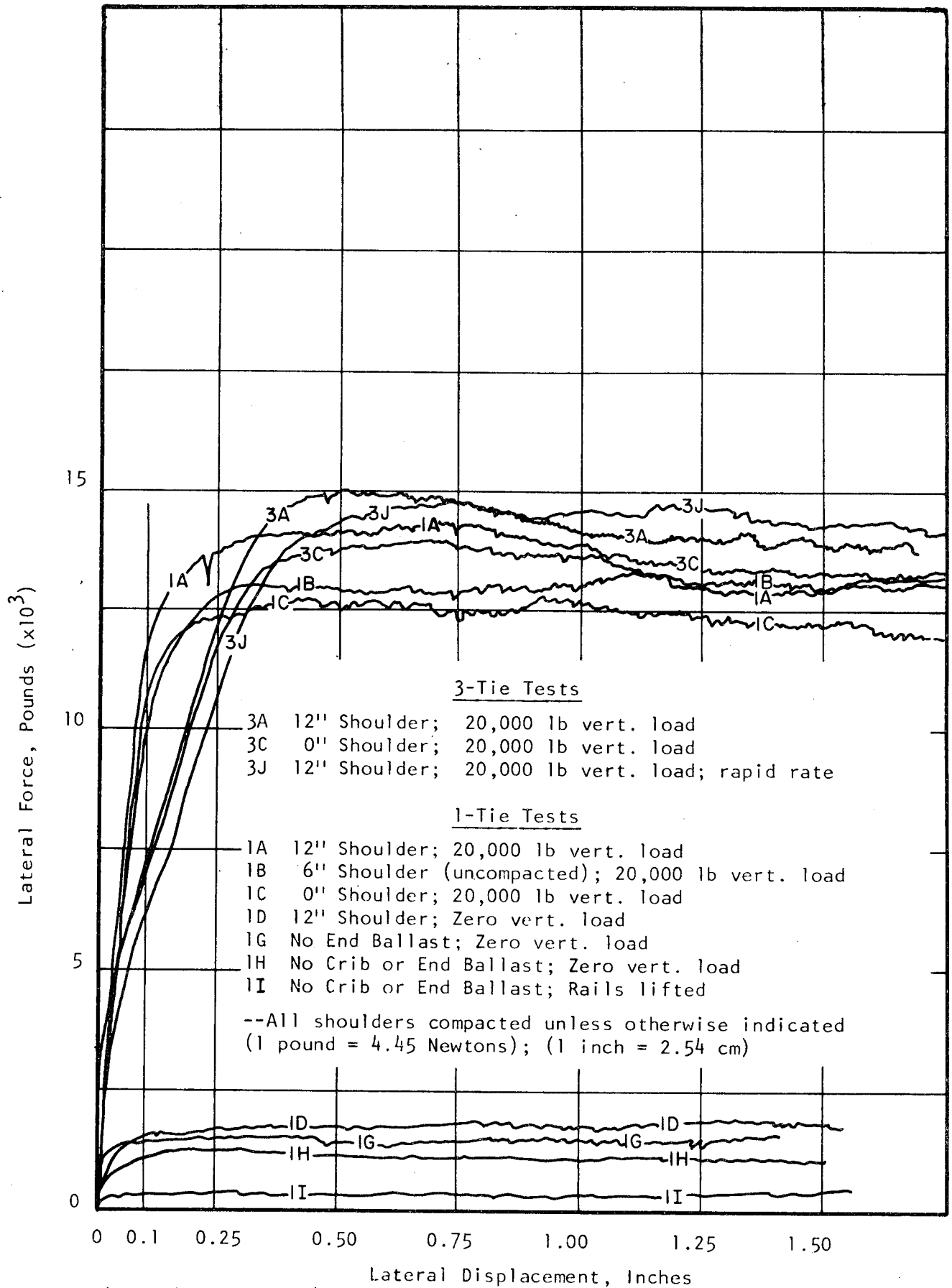

Figure 10. Number 4 Gravel: Lateral Force vs Lateral Displacement

slope, force at 0.1" (2.5 mm) displacement, and force at 0.25" (6.4 mm) displacement invalid. The 3-tie tests were uniformly performed for each material; 3 tests on each material under the same conditions. (See Tables 1, 2, and 3). Figure 11 shows the average force versus displacement curves for the loaded 3-tie tests for the three ballast types.

1. Peak Resisting Force - This is the maximum resisting force exerted by the ballast during a test and is an important factor in determining stability. Ideally, a ballast will have a very high peak resisting force.

The results show that while slag tends to have the highest value and gravel the least, the averages are within 10 percent of each other. With the 20,000 lb (89 kN) load distributed over three ties, the results indicate an L/V ratio (lateral force/vertical force) of about 0.8. Recent tests have shown wheel lift occurring at L/V of 0.8 and wheel climb at L/V of nearly 1.3.²⁰ Thus, before derailing, a train might exert lateral forces high enough to exceed the lateral stability of the track structure.

As pointed out earlier, the L/V ratio is not constant.¹⁹ It tends to decrease with increasing vertical loads up to about 25,000 pounds (111 kN). At higher vertical loads, this decrease begins to level off. (See Figure 1). The University of Illinois tests were conducted under simulated axle loads as much as three times lower than those found in actual service. Therefore,

Table 1. Lateral Stability Test Results

Material	Line	Test	Number of Ties	Shoulder Width	Vertical Load	Peak Force	(a) Yield Force	(a) Yield Force (% of Peak)	(a) Yield Displacement
Slag	1	1G	1	--	0	2.0	--	--	--
	2	1D	1	12	0	2.5	--	--	--
	3	1C	1	0	20	13.7	12.1	88	--
	4	1A	1	12	20	14.0	11.4	81	0.17
	5	3B	3	0	20	16.0	15.0	94	0.44
	6	3C	3	0	20	16.9	16.0	95	0.46
	7	3A	3	12	20	15.5	14.5	93	0.37
	8	3J	3	12	20	16.0	14.7	92	0.35
Limestone	9	1G	1	--	0	2.0(b)	--	--	--
	10	1D	1	12	0	2.0(b)	--	--	--
	11	1C	1	0	20	15.0	11.7	78	0.14
	12	1K	1	0	20	14.0	10.6	76	0.13
	13	1B	1	6	20	14.2	11.3	80	0.13
	14	1A	1	12	20	15.7	13.7	87	0.15
	15	1J	1	12	20	13.5	12.3	91	0.11
	16	3C	3	0	20	15.3	14.0	92	0.36
	17	3A	3	12	20	16.2	15.0	93	0.37
	18	3K	3	12	20	15.3	13.7	90	0.32
Gravel	19	1G	1	--	0	1.5	--	--	--
	20	1D	1	12	0	1.8	--	--	--
	21	1C	1	0	20	12.8	10.9	85	0.11
	22	1B	1	6	20	13.3	11.4	86	0.13
	23	1A	1	12	20	14.3	12.5	87	0.11
	24	3C	3	0	20	14.0	13.0	93	0.31
	25	3A	3	12	20	15.0	14.0	93	0.33
	26	3J	3	12	20	14.8	13.3	90	0.35
Sand	27	1J	1	12	50	21.5	20.0	93	0.25
	28	3M	3	12	20	17.7	20.0	93	0.25

All Loads and Forces are in 1,000's of Pounds. (1 Pound = 4.45 Newtons)

All Displacements and Shoulder Widths are in Inches. (1 Inch = 2.54 Centimeters)

(a) A yield point was chosen as the approximate point at which the curve changed from essentially a straight line to that of a pronounced curve.

(b) These results may have been affected by test irregularities.

Table 1. (Continued)

Material	Line	Test	Force at 0.25" Dis- placement	Force at 0.1" Dis- placement	(c) Approximate Straight Line Equation	(d) Slope M	Other Conditions
Slag	1	1G	--	--	--	--	No End Ballast
	2	1D	--	--	--	--	
	3	1C	7.0	3.0	y = Mx	30	
	4	1A	12.3	7.9		79	
	5	3B	10.8	5.8		58	
	6	3C	11.1	5.8		58	
	7	3A	11.2	5.8		58	
	8	3J	11.9	5.8		58	Rapid Rate
Limestone	9	1G	--	--	--	--	No End Ballast
	10	1D	--	--	--	--	
	11	1C	13.0	10.2	y = Mx	102	
	12	1K	12.5	9.6		96	Rapid Rate
	13	1B	12.7	10.2		102	
	14	1A	14.7	11.7		117	Uncompacted Shoulder
	15	1J	13.6	11.8		118	Rapid Rate
	16	3C	11.5	6.5		65	
	17	3A	12.0	7.5		75	
18	3K	11.7	7.0		70	Rapid Rate	
Gravel	19	1G	--	--	--	--	No End Ballast
	20	1D	--	--	--	--	
	21	1C	12.4	10.8	y = Mx	108	
	22	1B	12.8	10.2		102	
	23	1A	13.7	11.9		119	
	24	3C	11.9	7.1	-	71	
	25	3A	12.4	7.3		73	
	26	3J	10.8	6.2		62	Rapid Rate
Sand	27	1J	20.3	14.1	y = Mx	141	
	28	3M	16.5	10.6		106	

All Loads and Forces are in 1,000's of Pounds. (1 Pound = 4.45 Newtons)

All Displacements and Shoulder Widths are in Inches. (1 Inch = 2.54 Centimeters)

(c) These equations are intended to model the curves below the yield point.
y = value on the Force axis, M = slope of line, x = value on Displacement axis.

(d) These slopes were obtained as follows: $M = \frac{\text{Force at 0.1 inch displacement}}{0.1 \text{ (inch)}} \text{ kips/inch}$

Table 2. Lateral Stability Test Results

Line	Material	Test	Shoulder Width	Peak Force	Displacement at Peak Force	Yield Force (a)	Displacement at Yield Force	Force at 0.25" Displacement	Force at 0.1" Displacement	Other Conditions
1	Limestone	3A	12	16.2	0.90	15.0	0.37	12.0	7.0	
2	Slag	3A	12	15.5	0.60	14.5	0.37	11.2	5.8	
3	Gravel	3A	12	15.0	0.50	14.0	0.33	12.4	7.3	
4	Sand	3M	12	17.7	0.41	16.5	0.25	16.5	10.6	
5	Slag	3J	12	16.0	0.57	14.7	0.35	11.9	5.8	Rapid Rate
6	Limestone	3K	12	15.3	0.75	13.7	0.32	11.7	7.0	Rapid Rate
7	Gravel	3J	12	14.8	0.75	13.3	0.35	10.8	6.2	Rapid Rate
8	Slag	3B	0	16.0	0.61	15.0	0.44	10.8	5.8	Seated at 1.5 c.p.s.
9	Slag	3C	0	16.9	0.63	16.0	0.46	11.1	5.8	
10	Limestone	3C	0	15.3	0.75	14.0	0.36	11.5	6.5	
11	Gravel	3C	0	14.0	0.67	13.0	0.31	11.9	7.1	
12	Limestone	1A	12	15.7 (15.0)	1.15 (0.35)	13.7	0.15	14.7	11.7	Uncompacted Shoulder
13	Gravel	1A	12	14.3	0.75	12.5	0.11	13.7	11.9	
14	Slag	1A	12	14.0 (13.9)	1.06 (0.72)	11.4	0.17	12.3	7.9	
15	Limestone	1J	12	13.5	0.28	11.7	0.14	13.0	10.2	Rapid Rate
16	Limestone	1B	6	14.2 (13.8)	1.50 (0.70)	11.3	0.13	12.7	10.2	
17	Gravel	1B	6	13.3 (13.1)	1.10 (0.31)	11.4	0.13	12.8	10.2	
18	Limestone	1C	0	15.0	0.80	11.7	0.14	13.0	10.2	
19	Slag	1C	0	13.7 (13.0)	1.07 (0.55)	12.1	(b)	(b)	(b)	
20	Gravel	1C	0	12.8	0.40	10.9	0.11	12.4	10.8	
21	Limestone	1K	0	14.0	0.53	10.6	0.13	12.5	9.6	Rapid Rate

All Tests in Lines 1 to 21 with 20,000 Pound (89,000 Newtons) Vertical Force

Table 2. (Continued)

Line	Material	Test	Shoulder Width	Peak Force	Displacement at Peak Force	Yield Force (a)	Displacement at Yield Force	Force at 0.25" Displacement	Force at 0.1" Displacement	Other Conditions
22	Slag	1D	12	2.50	0.20	--	--	--	--	
23	Limestone	1D	12	2.00	0.28	--	--	--	--	
24	Gravel	1D	12	1.80	0.25	--	--	--	--	
25	Slag	1G	--	2.00	0.12	--	--	--	--	No End Ballast
26	Limestone	1G	--	2.00(b)	0.75	--	--	--	--	No End Ballast
27	Gravel	1G	--	1.50	0.20	--	--	--	--	No End Ballast
28	Slag	1H	--	1.30	0.09	--	--	--	--	No Crib or End Ballast
29	Limestone	1H	--	1.30	0.14	--	--	--	--	No Crib or End Ballast
30	Gravel	1H	--	1.30	0.18	--	--	--	--	No Crib or End Ballast
31	Gravel	1I	--	0.40	--	--	--	--	--	{No Ballast
32	Limestone	1I	--	0.34	--	--	--	--	--	Above Tie Bottom,
33	Slag	1I	--	0.26	--	--	--	--	--	Rails Lifted}

All Tests in Lines 22 to 33 with No Vertical Force.

(a) A yield point was chosen as the approximate point at which the curve changed from essentially a straight line to that of a pronounced curve.

(b) These results affected by test irregularities.

Numbers in parentheses are "secondary" peaks.

(One Pound = 4.45 Newtons)

(One Inch = 2.54 cm)

Table 3. Test Result Averages

MEASURED FACTOR	CONDITIONS	Material		
		SLAG	LIME-STONE	GRAVEL
YIELD FORCE	1-tie tests	11.75 (98.6)	11.92 (100)	11.60 (97.3)
	3-tie tests	15.05 (100)	14.23 (94.6)	13.43 (89.3)
	Tests 1A and 1C	11.75 (92.5)	12.70 (100)	11.70 (92.1)
PEAK RESISTING FORCE	1-tie tests	13.85 (95.7)	14.48 (100)	13.47 (93.0)
	3-tie tests	16.10 (100)	15.60 (97.3)	14.60 (90.9)
YIELD DISPLACEMENT	1-tie tests	0.170	0.132	0.117
	Test 1A	0.170	0.150	0.110
	3-tie tests	0.405	0.350	0.330
RESISTING FORCE AT 0.1" DISPLACEMENT	1-tie tests	7.90 (71.8)	10.70 (97.3)	11.00 (100)
	Test 1A	7.90 (66.4)	11.70 (98.3)	11.90 (100)
	3-tie tests	5.80 (84.4)	6.67 (97.1)	6.87 (100)
RESISTING FORCE AT 0.25" DISPLACEMENT	1-tie tests	12.30 (92.5)	13.30 (100)	12.97 (97.5)
	3-tie tests	11.25 (95.9)	11.73 (100)	11.70 (99.7)
1-TIE NO VERTICAL LOAD	12 Inch shoulder (test 1D)	2.50	2.00*	1.80
	No End Ballast (test 1G)	2.00	2.00*	1.50
	No Ballast Above Tie Bottom	1.30	1.30	1.30
	No Ballast Above Tie Bottom, Rails Lifted	0.26	0.34	0.40

--All FORCES are in 1,000's of POUNDS (One Pound = 4.45 Newtons)

--All DISPLACEMENTS are in INCHES (One Inch = 2.54 cm)

--Number in parentheses represent percentages. The best performing material is assigned a value of 100 percent.

*There were some uncertain test conditions associated with these tests.

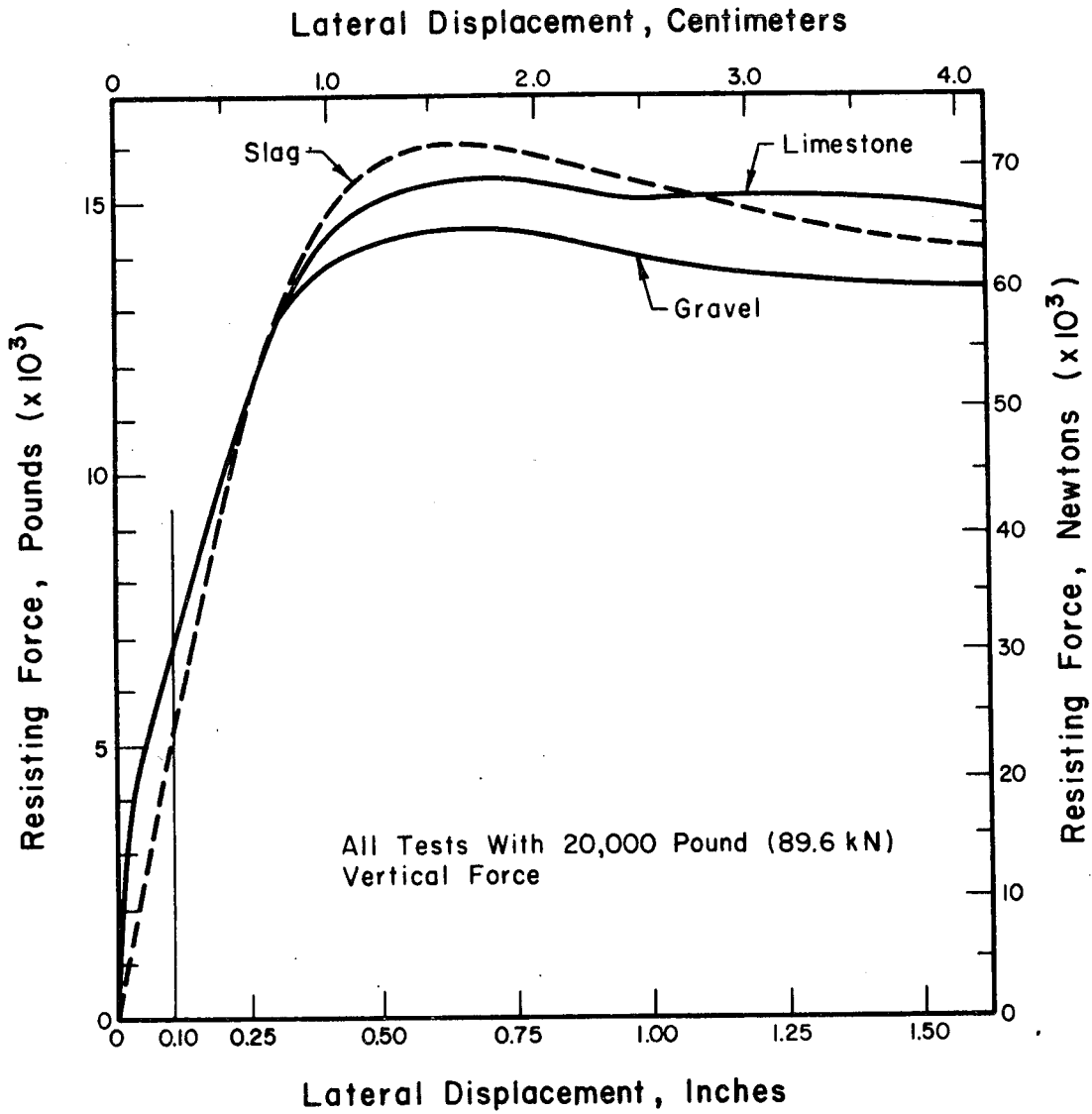

Figure 11. Average Force vs Displacement Curves for Loaded 3-Tie Tests

the resulting L/V ratios will be slightly higher than those obtained from actual service tests.

2. Displacement at Peak Resistance - While peak resistance is important, by definition, stability has been lost if any significant movement occurs, especially in the case of permanent displacement. Because the peaks were difficult to clearly define, especially for the 1-tie tests, only estimates of these displacements can be made. They are on the order of 0.5 inches to 0.6 inches (1.3 to 1.5cm). As this is past the limit of elastic displacement, track sustaining such movement would require realignment.

Because significant permanent displacement has taken place, it is necessary to examine the initial parts of the test curves. At the present displacements, it would be necessary for track gangs to restore the track to its original alignment. Therefore it is important to see how the ballast materials perform in the range below that of permanent displacement.

3. Yield Force - The test curves are generally similar in shape to those of a standard steel tensile test. This allowed a yield point, similar to that for steel, to be determined. Again, relying mostly on the 3-tie tests with 20,000 pound (89 kN) vertical load, the results are similar to the comparison among peak resisting forces. Slag is highest and gravel is lowest; all within about 10% of each other.

4. Displacement at Yield - It is desirable that displacement be small. For the 1-tie tests, the displacements are on the order of 1/8 inches to 3/16 inches (3.2 to 4.8 mm), near the limit of elastic displacement. The 3-tie tests have yield displacements in the 0.33 to 0.405 inch (0.84 to

1.03 cm) range, above the elastic limit. (Allowance for slack in test apparatus has been considered.)

5. Yield Force as a Percentage of Peak Resisting Force - The yield point represents the limit of the initial part of the force/displacement curves. In this initial part of the curve, the resisting forces are high compared with the corresponding displacements. It is therefore desirable that the yield force be a very high percentage of the peak resisting force. All tests on each ballast indicate good performance in this area, the 1-tie tests averaging just under 90 percent and the 3-tie tests just over 90 percent. The 3-tie tests show slag with a slightly higher average than limestone or gravel. The results for the 1-tie tests are mixed.

6. Slope of Initial Part of Curve - A steep slope is desirable as this indicates relatively high resisting forces at very small displacements. For the 1-tie tests, conclusions are difficult to make, but slag seems to have significantly lower slope values than either limestone or gravel. For the 3-tie tests, the three materials are nearly equal, with slag having a slightly higher average slope than limestone and gravel. The latter two materials have almost identical averages. Therefore the slope comparison does little to show any differences in the materials' stability.

For steep slopes, numerical values can be misleading. Angular measure might have been better, but as the slopes are only rough estimates and did little to help differentiate between the materials, this additional measurement was felt to be unnecessary.

The reason for the "kink" or sudden change in the slopes of the 1-tie tests for both gravel and limestone is not clearly understood. These occur

near forces of 3,500 pounds (15.6 kN) for gravel and 5,000 pounds (22.3 kN) for limestone (See Figures 7, 8, 9 and 10).

7. Resistance at 0.1 inch (2.5 mm) and 0.25 inch (6.4 mm) Displacements -

Ideally, a ballast will offer high resistance at small displacements. Because the initial parts of the test curves were not straight, something other than a slope comparison was needed. Comparing resisting forces at certain "critical" small displacements could give a good indication of the stability each ballast provides. A 0.1 inch (2.5 mm) displacement is within the elastic range and a 0.25 inch (6.4 mm) displacement is still small, being below the yield point for all 3-tie tests. These limits are approximately those of the minimum and maximum desirable displacements, respectively. (As a ballast section should have some resilience in the vertical direction, likewise, it seems appropriate to require some lateral resilience to lessen the shocks on both track structure and equipment.)

For both the 1-tie and 3-tie tests limestone and gravel perform about equally with slag noticeably below the other two materials. (For this category, there is only one reliable 1-tie test for slag, while there are five for limestone.)

8. Resistance with Zero Vertical Load, and Corresponding Displacements -

This situation approximates that the unloaded track, and allows a look at the resistance each ballast provides against, for example, thermal stresses in welded rail which tend to force track out of alignment. All tests in this category are 1-tie tests, and in most cases, peak resisting force is reached within 0.1 inches (2.5 mm) displacement.



CHAPTER 4

SUMMARY AND CONCLUSIONS

4.1 LATERAL RESISTANCE VS. BALLAST TYPE

Comparisons among the ballast materials will be based primarily on the 3-tie tests. These appear to better represent actual track conditions than do the 1-tie tests, and were more uniformly performed among the three materials. In addition, the eight parameters (as described in section 3.4) have been combined into three categories which are peak resistance, small displacements, and zero vertical load. These were chosen to represent the most common or more important operating situations. Comparisons are based on an overall average performance within each category.

Peak Resistance - This category indicates the relative maximum resistance offered by each of the materials under a 20,000 pound (89 kN) vertical load to both rails. This maximum lateral resistance occurred at displacements in the range of 1 to 1½ inches (2.54 to 3.81 cm), well beyond the elastic limit. Such large displacements may correspond to heavy run-in or derailment conditions which could cause lateral forces great enough to slide the track in the ballast section.

The relationship among the materials, found by an averaging of the test results, is practically identical between the 1-tie and 3-tie tests. While slag offered the highest resistance and gravel the least, the difference between the two was only about ten percent. Limestone's performance fell nearly half way between those of slag and gravel. (See Table 3).

In this situation, displacements are relatively unimportant, as track which has been moved enough to develop peak resistance in the ballast must be realigned immediately. However, a ballast with a high peak resistance

will help to restrain track which is subjected to large lateral forces, and thus provide an extra margin of safety against lateral failure (buckling).

Small Displacements - In this second category, lateral resistance was measured at a displacement of 0.1 inches (2.5 mm), which corresponds approximately to the elastic limit as determined in the SNCF tests.¹⁹

At displacements within the elastic limit, the resistance offered is that which could be expected without a loss of track alignment. Performance in this category may give an indication of the ability of each ballast type to hold the track in alignment under a passing train.

For gravel and limestone, the averages of the 1-tie and 3-tie tests showed nearly identical results. This was not the case with slag, which had only one reliable 1-tie test. The performances of limestone and gravel are nearly the same, with slag noticeably below. (See Table 3).

Zero Vertical Load - The third comparison was made using an unloaded track section. Data were taken from test ID, in which a full 12-inch (30.5 cm) shoulder was used.

This third category may serve to indicate the ability of each ballast to hold the track in alignment with no train passing over. Lateral stability in the unloaded condition is especially important in welded rail territory, where high thermal forces must be resisted. With welded rail, a 12-inch (30.5 cm) shoulder is commonly used, as in test ID. The results of this test show slag providing at least 25 percent more resistance than either limestone or gravel.

4.2 EFFECT OF SHOULDER WIDTH

The tests carried out under a 20,000 pound (89 kN) vertical track load indicate that a 12-inch (30.5 cm) shoulder provides no significant increase in lateral resistance over that of a 6-inch (15.2 cm) or even a 0-inch shoulder. As seen in Table 1, comparisons among tests made with different shoulder widths show mixed results. Thus, the addition of a ballast shoulder beyond the tie end showed no clear benefit with respect to lateral stability while under load.

Unlike the loaded track condition, in which the resistance offered is almost solely a function of material properties, the resistance to lateral forces obtained with unloaded track partly depends on the amount of ballast shoulder present. Tests with slag and gravel show an increase in peak resistance of 20 percent with the addition of a 12-inch (30.5 cm) shoulder over that measured with the No End Ballast condition (tests 1D and 1G). The results for limestone were inconclusive, but with a 12-inch (30.5 cm) shoulder, the peak resistance of this ballast did occur at smaller displacement than with the No End Ballast condition.

The SNCF tests¹³ also showed that a larger ballast section could increase the lateral stability of unloaded track by 20 percent. Exact comparisons, however, are difficult due to the lack of detailed descriptions of the ballast sections tested and the differences between American and French practice.

So it appears that the effective lateral resistance provided by a ballast shoulder varies with the magnitude of the vertical load; the percentage of extra resistance obtained decreasing as the vertical load increases.

4.3 OBSERVATIONS AND SUGGESTIONS FOR FURTHER TESTS

Due to economic limitations the tests performed were rather limited in number. Thus, the conclusions in this report have been based on a very small sample. For the most part, each set of conditions underwent only one test run for each material, and as samples of slag, limestone, and gravel can vary considerably from different sources (even within the same A.R.E.A. gradation) it was difficult to assign any absolute stability values to these materials.

In addition to determining peak resistance, it may be valuable to know the limit of elastic displacement for various ballast materials. Such a measurement, in both the loaded and unloaded conditions, would give a better indication as to the ability of a ballast to hold and maintain track alignment. Once permanent displacement has been reached, alignment has been lost, and it is then that the expense of restoring alignment must be incurred.

In the University of Illinois tests, shoulder resistance was measured using one tie. A track panel with several ties would more accurately represent actual track conditions and might therefore give a better indication of shoulder resistance.

Additional tests might also include a larger variety of ballast materials and gradations, as well as dynamic loadings to better simulate passing trains.

LIST OF REFERENCES

1. Federal Railroad Administration, Track Safety Standards, FR Doc. 71-15279, Washington, D.C., 1971, pp. 213.9 and 213.55.
2. Federal Railroad Administration - Railroad Safety Board, Railroad Accident Investigation Summary Report #42, Department of Transportation, Washington, D.C., 1973.
3. W. W. Hay, Railroad Engineering. Vol. 1, John Wiley & Sons, Inc., New York, 1953, pp. 297-298.
4. O. W. Clarke, Track Loading Fundamentals, Pt. 1-7, Railway Gazette, 1957, Vol. 106, No. 2, January 11, pp. 45-48; No. 4, January 25, pp. 103-107; No. 6, February 8, pp. 157-160, 163; No. 8, February 22, pp. 220-221; No. 10, March 8, pp. 274-278; No. 12, March 22, pp. 335-336; April 26, pp. 479-481.
5. F. Birmann, Lateral Strength or Resistance of the Track, Schnell Fahrt & Oberbau, 1971, pp. 45-49.
6. Keeping the Track in Its Place, Railway Gazette, Vol. 125, No. 19, October 1969, p. 720.
7. Kazuyosi Ono and Yosio Itoo, Analysis of the Vibrations in the Railway Track, Study at Kanazawa University, Japan, 1974.
8. G. M. Magee, Stabilized Ballast Investigation, Department of Transportation, Washington, D. C., 1969, PB 192 720.
9. "Welded" Ballast, Railway Track and Structures, November 1970, pp. 121-123.
10. E. L. Robinson, et al., Report on Assignment 10: Ballast, AREA Proceedings, Vol. 70, 1969, Chicago, pp. 656-657.
11. Dr. G. P. Raymond, et al., A Study of Stresses and Deformations under Dynamic and Static Load Systems in Track Structure and Support, Project 2.22, Canadian Institute of Guided Ground Transport Annual Report, Queens University, Kingston, Ontario, 1974, pp. 49-89.
12. Ir. B. van Bilderbeek, Ir. H. J. Th. Span, et al., Road and Railroad Research Laboratory, Research Activities, Department of Civil Engineering, Delft University of Technology, Netherlands, 1971-1973, pp. 164-170.
13. Roger Sonnevile and Andre Bentot, Lateral Strength of Permanent Way When Free from Load, Bulletin of the International Railway Congress Association, Vol. 33, No. 6, June 1956, pp. 481-491.

14. A. T. Goldbeck, et al., Report on Assignment 10: Ballast, AREA Proceedings, Vol. 54, 1953, Chicago, pp. 1140-1148.
15. E. L. Robinson, et al., Report on Assignment 2: Ballast, AREA Proceedings, Vol. 71, 1970, Chicago, pp. 579-583.
16. A. N. Talbot, et al., Second Progress Report of the Special Committee to Report on Stresses in Railroad Track, ASCE Transactions, No. 1455, 1919.
17. M. T. Salem and W. W. Hay, Vertical Pressure Distribution in the Ballast Section and on the Subgrade Beneath Statically Loaded Ties, Civil Engineering Studies - Transportation Series No. 1, University of Illinois at Urbana-Champaign, 1966.
18. M. T. Salem, Vertical Pressure Distribution in the Ballast Section and on the Subgrade Beneath Statically Loaded Ties, Ph.D. Thesis, University of Illinois at Urbana-Champaign, 1966.
19. Roger Sonnevile and Andre Bentot, Elasticity and Lateral Strength of the Permanent Way, Bulletin of the International Railway Congress Association, Vol. 32, No. 3, March 1955, pp. 184-208.
20. A. E. Hinson, Reliability Analysis Approach to Improving Train Operations, Proceedings of the Conference on Track/Train Dynamics Interaction, December 1971, Vol. 1, pp. 235-236.
21. A. T. Goldbeck, et al., Report on Assignment 10a: Ballast: Tests, AREA Proceedings, Vol. 48, 1947, Chicago, pp. 544-546.
22. H. O. Ireland, Railroad Subgrade Stresses, AREA Bulletin 641, Chicago, 1973.
23. H. C. Meacham and D. R. Ahlbeck, A Computer of Dynamic Loads Caused by Vehicle-Track Interaction, Transactions of the ASME, August 1969, pp. 808-816.
24. Ballast Compaction - A Preliminary Report, C N Engineering Technical Information Bulletin, Canadian National Railway, 1974.
25. What Benefits from Ballast Compaction? Railway Track and Structures, February 1974, pp. 25-31.
26. British Transport Commission, Experiments on the Stability of Long-Welded Rails, London, 1961.
27. V. E. Nemkova, Developing Automatic Control of Ballast Density, Put i putew chosj, RT 34068/66, December 1965, pp. 5-8.
28. I. A. Reiner, Testing Concrete Ties, Proceedings of the 12th Annual Railroad Conference, held at Pueblo, Colorado, October 23 and 24, 1975. FRA-OR&D 76-243, October, 1975.