

PB289-148



REPORT NO. FRA/ORD-77/73, II

RAIL SAFETY/EQUIPMENT CRASHWORTHINESS

Volume II: Design Guide

M.J. Reilly
J. Shefrin
L.M. Patrick

Boeing Vertol Company
P.O. Box 16858
Philadelphia PA 19142



JULY 1978
INTERIM REPORT

DOCUMENT IS AVAILABLE TO THE U.S. PUBLIC
THROUGH THE NATIONAL TECHNICAL
INFORMATION SERVICE, SPRINGFIELD,
VIRGINIA 22161

Prepared by
U.S. DEPARTMENT OF TRANSPORTATION
FEDERAL RAILROAD ADMINISTRATION
Office of Research and Development
Washington DC 20590

REPRODUCED BY
NATIONAL TECHNICAL
INFORMATION SERVICE
U.S. DEPARTMENT OF COMMERCE
SPRINGFIELD, VA. 22161

NOTICE

This document is disseminated under the sponsorship of the Department of Transportation in the interest of information exchange. The United States Government assumes no liability for its contents or use thereof.

NOTICE

The United States Government does not endorse products or manufacturers. Trade or manufacturers' names appear herein solely because they are considered essential to the object of this report.

1. Report No. FRA/ORD-77/73, II		2. Government Accession No. PB289148		3. Recipient's Catalog No.	
4. Title and Subtitle RAIL SAFETY/EQUIPMENT CRASHWORTHINESS Volume II: Design Guide				5. Report Date July 1978	
7. Author(s) M. J. Reilly, J. Shefrin, L. M. Patrick				6. Performing Organization Code	
9. Performing Organization Name and Address Boeing Vertol Company* Philadelphia PA 19142 P.O. Box 16858				8. Performing Organization Report No. D339-10022-1 DOT-TSC-FRA 77-15, II	
12. Sponsoring Agency Name and Address U.S. Department of Transportation Federal Railroad Administration Office of Research and Development Washington DC 20590				10. Work Unit No. (TRAIS) RR728/R8327	
15. Supplementary Notes *Under contract to: U.S. Department of Transportation Research and Special Programs Administration Transportation Systems Center Cambridge MA 02142				11. Contract or Grant No. DOT-TSC-821-2	
16. Abstract <p>The Department of Transportation, Transportation Systems Center (TSC), is providing technical assistance to the Federal Railroad Administration (FRA) in a program to improve railroad safety and efficiency by providing a technological basis for improvement and possible regulation in rail vehicle crashworthiness, inspection and surveillance of equipment, and other areas. As part of this program, TSC is conducting technical analyses of passenger railcar collisions, derailments, and other accidents, directed towards minimizing occupant injuries.</p> <p>This Design Guide, the second of four volumes, has been prepared to assist design engineers in understanding the basic problems associated with the development of crashworthy interiors of locomotives, cabooses and passenger railcars. Rail vehicle accident conditions are presented with the resulting interactions that can occur between one car and another. Types of injuries to the occupants of the cars, and the mechanism causing the injury, are discussed.</p> <p>Volume I reports on the collection of data for a representative accident sample. Volume III proposes engineering standards in the format of the <u>Code of Federal Regulations</u> (Title 49, Transportation, Parts 200). Volume IV is an executive summary.</p>				13. Type of Report and Period Covered Interim Report 6/74 - 9/76	
17. Key Words Caboose Crashworthy Collision Containment Restraint		Energy Attenuating Delethalization Human Tolerance Locomotive Passenger Railcar		18. Distribution Statement DOCUMENT IS AVAILABLE TO THE U.S. PUBLIC THROUGH THE NATIONAL TECHNICAL INFORMATION SERVICE, SPRINGFIELD, VIRGINIA 22161	
19. Security Classif. (of this report) Unclassified		20. Security Classif. (of this page) Unclassified		22. Price \$0.45 1/11 1/11	

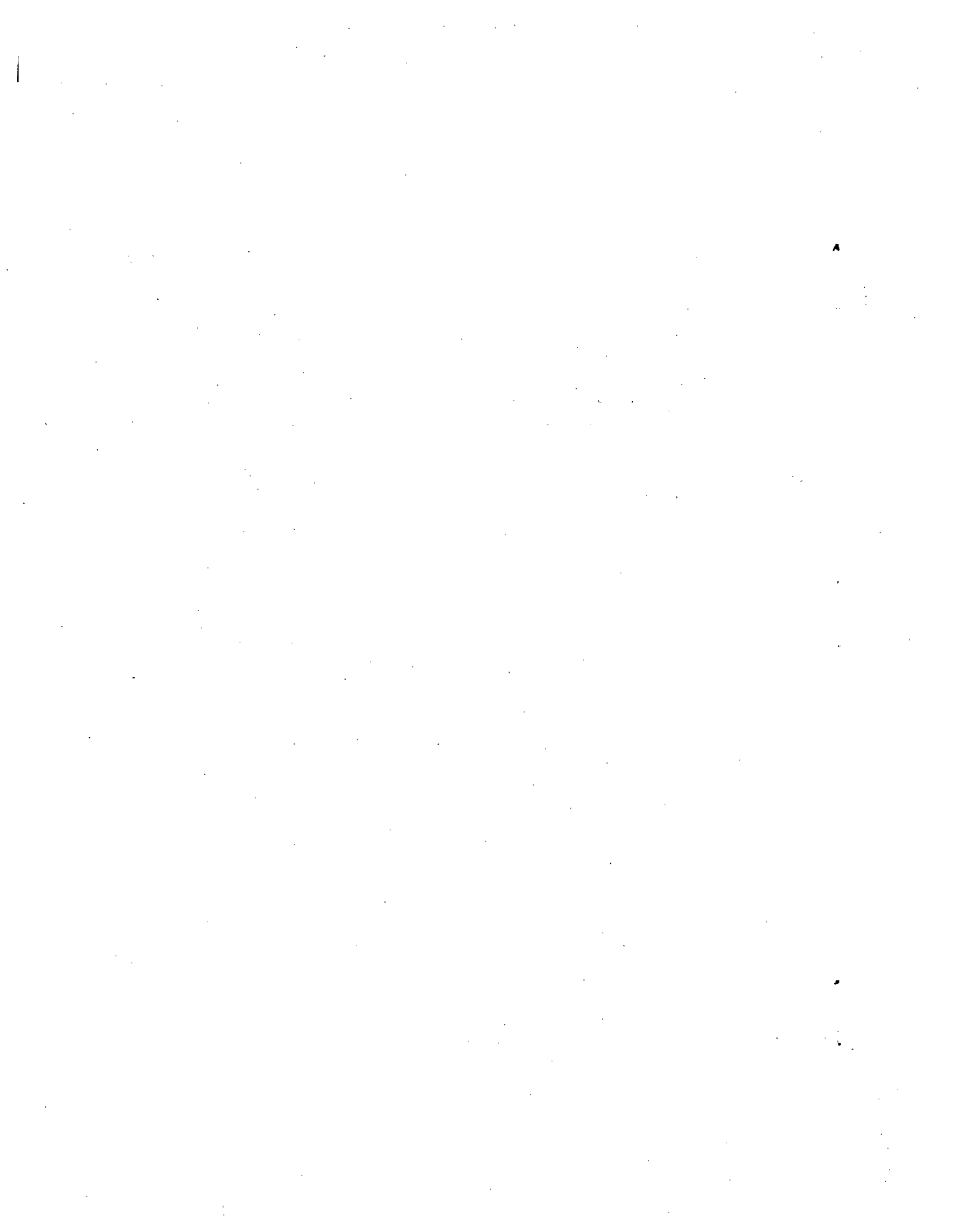

PREFACE

As part of a program to provide a technological basis for improvement in rail vehicle crashworthiness, inspection of equipment, surveillance of equipment and other areas, Transportation Systems Center has conducted technical analyses of passenger carrying rail vehicle collisions, derailments and other accidents.

This document summarizes the activities completed under this study contract wherein a) the accident data was reviewed, analyzed and categorized; b) design changes for improved occupant protection were suggested and c) proposed standards of application of the safety requirements were prepared. The author wishes to acknowledge assistance received from both Electro-Motive Division of General Motors and Prof. L. M. Patrick of Wayne State University under subcontract agreements. Acknowledgement is also made of the assistance provided by International Car Company of Kenton, Ohio and the former Penn Central Transportation Company. Additional credit is due to the many authors whose publications were referenced in the individual Interim Technical Reports.

METRIC CONVERSION FACTORS

Approximate Conversions to Metric Measures				Approximate Conversions from Metric Measures			
Symbol	When You Know	Multiply by	To Find	Symbol	When You Have	Multiply by	To Find
LENGTH							
in	inches	2.5	centimeters	mm	millimeters	0.04	inches
ft	feet	30	centimeters	cm	centimeters	0.4	inches
yd	yards	0.9	meters	m	meters	3.3	feet
mi	miles	1.6	kilometers	km	kilometers	0.6	miles
AREA							
sq in	square inches	6.5	square centimeters	sq cm	square centimeters	0.16	square inches
sq ft	square feet	0.09	square meters	sq m	square meters	1.2	square yards
sq yd	square yards	0.8	square meters	sq km	square kilometers	0.4	square miles
ac	acres	2.6	hectares	ha	hectares (10,000 m ²)	2.5	acres
MASS (weight)							
oz	ounces	28	grams	g	grams	0.035	ounces
lb	pounds (16 oz)	0.45	kilograms	kg	kilograms	2.2	pounds
	short tons (2000 lb)	0.9	tonnes	t	tonnes (1000 kg)	1.1	short tons
VOLUME							
tblsp	tablespoons	5	milliliters	ml	milliliters	0.03	fluid ounces
fl oz	fluid ounces	30	milliliters	l	liters	2.1	pints
c	cups	0.24	liters	qt	quarts	1.06	quarts
pt	pints	0.47	liters	gal	gallons	0.26	gallons
qt	quarts	0.95	liters	cu ft	cubic feet	35	cubic feet
gal	gallons	3.8	cubic meters	cu yd	cubic yards	1.3	cubic yards
cu ft	cubic feet	0.03	cubic meters	TEMPERATURE (exact)			
cu yd	cubic yards	0.76	cubic meters	°C	Celsius temperature	9/5 (then add 32)	Fahrenheit temperature
TEMPERATURE (exact)							
°F	Fahrenheit temperature	5/9 (then subtract 32)	Celsius temperature	°C	Celsius temperature	9/5 (then add 32)	Fahrenheit temperature



TABLE OF CONTENTS

<u>Section</u>	<u>Page</u>
1. INTRODUCTION	1
2. GENERAL DESIGN CRITERIA	4
3. RAIL VEHICLE INJURIOUS ENVIRONMENT	6
3.1 RAIL VEHICLE COLLISION DESIGN PULSE	6
3.1.1 Freight Locomotive Head-On Collision Pulse	6
3.1.2 Freight Locomotive and Caboose Rear-End Collision Pulse	9
3.1.3 Passenger Train Locomotive and Passenger Car Rear-End Collision Pulse	9
3.2 INJURY PRODUCING ENVIRONMENT	9
3.2.1 Locomotive Occupant Impact Hazards Environment	9
3.2.2 Caboose Occupants Impact Hazards Environment	15
3.2.3 Passenger Railcar Occupant Impact Hazards Environment	17
4. HUMAN TOLERANCE DATA	26
4.1 HEAD IMPACT	26
4.2 FACE IMPACTS	29
4.3 KNEE-THIGH-HIP COMPLEX IMPACT	30
4.4 FLEXION OR EXTENSION NECK INJURIES	30
4.5 FLAILING LIMBS	31
4.6 THORAX IMPACT	32
5. PROTECTIVE DESIGN CONSIDERATIONS	33
5.1 GENERAL CONSIDERATIONS	33
5.2 OCCUPANT RESTRAINT AND CONTAINMENT	33
5.2.1 Active Restraint Systems	34
5.2.2 Passive Restraint and Containment Systems	46
5.2.3 Passive Containment and Protection Systems	59
5.2.4 Passive Restraint and Containment Energy Absorption Design	66
5.3 RAIL VEHICLE INTERIOR DELETHALIZATION	81
5.3.1 Delethialized Surfaces	81
5.3.2 Equipment Securement	84
5.3.3 Material Selection	85
5.3.4 Glazing	85
REFERENCES	87
APPENDIX - New Technology	89

LIST OF ILLUSTRATIONS

<u>Figure</u>	<u>Page</u>
3-1 Freight Train Locomotives in Head-On Collision	7
3-2 Freight Trains in Rear-End Collision: Locomotive Impulse	10
3-3 Freight Trains in Rear-End Collision: Caboose Impulse	11
3-4 Passenger Car Impulse During Impact with Locomotive	12
3-5 Potential Hazards to Engineman Impact	13
3-6 Engineman Twisted by Forward Impact	13
3-7 Forward Acceleration Injury Potential - Fireman	14
3-8 Rearward Acceleration Whiplash - Fireman	14
3-9 Cupola Hazards Under Forward Acceleration	16
3-10 Cupola Hazards Under Side Acceleration	16
3-11 Conductor Impacting Desk Under Forward Acceleration	18
3-12 Conductor Without Restraint	18
3-13 Caboose Equipment Hazards	19
3-14 Caboose Lavatory Hazards	19
3-15 Injuries from Forward Acceleration - Passenger Railcar	21
3-16 Rollover Impact	22
3-17 Impact with Window	22
3-18 Lateral Sway	22
3-19 Longitudinal Acceleration - Passenger Lavatory	22

<u>Figure</u>	<u>Page</u>
3-20 Leg Entrapment	24
3-21 Lateral Impact	24
3-22 Longitudinal Impact	24
3-23 Lateral Sway	24
3-24 Lateral Acceleration Injury Potential	25
3-25 Snack Bar Partition	25
3-26 Snack Bar Appliances	25
5-1 Restraint System Concepts	35
5-2 Lap Belt Anchorage Geometry	36
5-3 Engineman's Rotational Envelope with Lap Belt .	38
5-4 Engineman Impact with Console	39
5-5 Helper Impact with Door	39
5-6 Engineman's Rotational Envelope with Shoulder Straps	41
5-7 Shoulder Restraint on Engineman	42
5-8 Shoulder Restraint on Helper	42
5-9 Rotational Envelope with Lap Belt - Caboose . . .	43
5-10 Conductor with Lap Belt Only	44
5-11 Brakeman with Lap Belt Only	45
5-12 Brakeman with Lap Belt and Diagonal Shoulder Strap	45
5-13 Rotational Envelope with Shoulder Straps - Caboose	47
5-14 Conductor with Double Shoulder Strap System . .	48
5-15 Engineman's Restraint Buffer - Forward Impact .	49
5-16 Helpers' Restraint Buffer - Forward Impact . . .	50
5-17 Existing Engineman's Station with Buffer and Padding	51

<u>Figure</u>	<u>Page</u>
5-18 Improved Crashworthiness Design Engineman's Station	53
5-19 Chest Buffer Installations in Caboose	56
5-20 Conductor Chest Buffer Restraint Rotational Envelope	57
5-21 Lateral Shoulder Buffer Restraint	58
5-22 Automatic Inflating Air Bag Restraint	58
5-23 Restraint and Containment Summary	67
5-24 Body Impact Velocity vs Distance Traveled	69
5-25 Cushion Penetration vs Cushion Thickness	70
5-26 Impact Pressure vs Cushion Stiffness	71
5-27 Passenger Railcar Collision, Occupant Impacts	74
5-28 Locomotive Collision Occupant Impacts	75
5-29 Caboose Collision Occupant Impacts	76
5-30 Shielded Windshield Wiper Motor	82
5-31 Recessed Light Panel	82

LIST OF TABLES

<u>Table</u>		<u>Page</u>
4-1	Injury Terms	27
4-2	Human Loading Tolerances	28
5-1	Locomotive Collision Injury Matrix	77
5-2	Caboose Collision Injury Matrix	78
5-3	Passenger Railcar Collision Injury Matrix	79

1. INTRODUCTION

The Transportation Systems Center (TSC), in providing technical assistance to the Federal Railroad Administration (FRA), has directed a program at improving railroad safety and efficiency through safer rail equipment. The basic problems in minimizing occupant injuries and fatalities (trainmen and passengers) in a collision environment are a function of: primary impact protection (injury due to structural crushing), secondary impact protection (injury due to occupant impacting structure or equipment), and safe post-crash egress. These problems are not mutually exclusive and their interaction must be considered in the analysis of potential design improvements. Included in secondary impact protection are provisions for safeguards against injury from train motions and normal operations.

In support of the TSC effort in improving occupant safety in rail vehicles, Boeing Vertol Company has been contracted to investigate both the primary and secondary impact protection problems under Contract DOT-TSC-856, "A Structural Survey of Classes of Vehicles for Crashworthiness", and Contract DOT-TSC-821, "Rail Safety-Equipment Crashworthiness", respectively.

The structural study (Contract 856) examines the impact effects which result from primary structural failure in several classes of vehicles. The goal of this study is to maintain a survivable occupant living space and to reduce equipment damage.

The rail safety study (Contract 821) concerns itself with the safety aspects of the interior environment of rail vehicles and addresses the problem of secondary impact effects on the occupants of locomotives, cabooses, and passenger cars. Also part of this study is a technical analysis of railcar accidents including passenger railcar collisions, derailments, and motions causing occupant injuries.

Together, these studies will provide a technological basis for crashworthy railcar structures; improved equipment performance specifications; and possible regulation of rail vehicle crashworthiness, inspection, and surveillance of equipment.

The 821 contract also provides for the preparation of a "Design Guide for Crashworthy Rail Vehicles and Equipment". It is the intent of this document to perform this function by

providing a technical base over the spectrum of hardware and interacting human subjects to assist designers in understanding the basic problems involved.

BACKGROUND: VEHICLE CRASHWORTHINESS STATE-OF-THE ART

Crash survivability study, test, and implementation in highway vehicles and aircraft have established a crash survival state-of-the-art.

Government requirements have been established for crash-worthiness of passenger cars, trucks, and buses, and for military aircraft. As a result, the development of crash-worthy features has been principally for these vehicles. The Department of Transportation (DOT) National Highway Traffic Safety Administration and the U.S. Army have issued regulations, standards, and guides for crashworthiness provisions. Safety and crashworthiness standards have been issued by DOT and are being incorporated in the manufacture of highway vehicles, with some standards directly applicable to rail vehicles.

The U.S. Army has issued the following documents dealing with aircraft crash safety standards:

TR71-22	Crash Survival Design Guide
MIL-STD-1290	Light Fixed- and Rotary-Wing Aircraft Crashworthiness
ADS-11	Aeronautical Design Standard Survivability Vulnerability

These documents present crashworthiness design data for potentially survivable aircraft crashes. Crash pulse criteria, human tolerances, and crash conditions are given in the document. Structural design principles are given for balancing strength and deformation and assuring retention of living space within the collapsed structure. Design criteria are specified for the design of crashworthy seats and restraint systems, and techniques for the delethalization of the occupied area are discussed. Requirements for minimizing post-crash fires and provision for maximizing emergency egress are discussed and specified.

Rather than being crash-oriented, existing federal regulations of the Department of Transportation's Federal Railroad Administration have been primarily based on accident safety. Amtrak locomotive specifications, however, include collision requirements for glass, seat structures, fire retardants, and escape provisions.

DATA SOURCE

Potential interior design improvements presented in this guide are based on:

- accident data
- current state-of-the-art design concepts used in other vehicles (such as automobiles and aircraft)
- development of new concept safety devices through fullscale mockups using live subjects, and the
- results of computer simulations of the dynamic response of occupants who impact vehicle interiors in typical accident scenarios.

Data collected from a representative accident sample was analyzed to identify injury types, locations, and when possible, injury causal factors. Vehicle interior design details are also considered in conjunction with the accident data to compile a listing of potential improvements and to develop occupant protection guidelines.

The analyzed sample consisted of accidents which occurred within the 1967-73 time frame, and warranted detailed investigation and the issuance of a formal report either by the National Transportation Safety Board (NTSB) or the FRA. This sample was selected because all reports were readily available and precluded excessive data searching into archive files.

Details on injuries sustained were obtained from FRA T-forms for the years 1972 and 1973. These data included injuries resulting from collisions, train motions, equipment failures and occupant clumsiness. Injuries occurred in locomotives, cabooses and passenger railcars.

As it now stands, the compilation on rail system crashworthiness in this document can be considered preliminary, since it is an initial effort, based on knowledge gained from other disciplines and innovative features and designs, which are unproven by test and operation. With use, experience with first generation crashworthy designs, better accident reporting and analysis, and updating with inputs from concerned users and agencies, its value will be considerably increased.

2. GENERAL DESIGN CRITERIA

The overall objectives in injury minimization to rail vehicle occupants in a collision are to restrain or contain seated occupants to prevent their being thrown into injurious objects, to minimize the distance unrestrained occupants are thrown and to remove injurious or loose objects from their environment. Cost minimization is an important factor in how these objectives are implemented. Another consideration in the implementation is whether the crashworthiness provisions are to be retrofitted into existing rail vehicles or are to be incorporated into new production vehicles. Keeping cost in mind, crashworthiness provisions for a new production vehicle may not be economically feasible to retrofit in an existing vehicle. Above all, consideration must be given to whether the device provided to prevent injury in a collision would be made use of if it required the occupant to willfully apply the device.

In general the design criteria for rail vehicle crashworthiness can be summed up in the following manner:

1. Restrain seated rail vehicle occupants from being thrown forward into an unyielding or hazardous surface.
2. Minimize the distance an unrestrained occupant can travel from their seated position to a non hazardous surface or object in front of them.
3. Assure that the object impacted in front of an unrestrained seated position presents a smooth surface free of protrusions and is sufficiently deformable or padded to absorb the impact energy, to reduce the forces below the injury threshold.
4. Provide sufficient seat back surface and strength to support the upper torso and head to prevent back and neck injury (whip-lash) due to rearward accelerations.
5. Eliminate the capability for passenger seats to be rotated to a face-to-face position or to become unlocked during a collision. (Seat rotation should be limited to train personnel using a special tool or key.)
6. Eliminate the capability for seated occupants legs to become wedged under a seat or equipment in front of them.

7. Eliminate or minimize hazardous furnishings such as window shades, unpadded or nonyielding sunvisors, flammable materials or materials which give off toxic fumes.
8. Equipment which is irregularly shaped or has a high temperature and which can be struck by standing rail vehicle occupants should be covered with shrouds, shields or flush panels.
9. Remove small irregularly surfaced objects mounted on bulkheads and stow in flush surface compartments.
10. Eliminate protective railings, grab rails and stanchions and replace with recessed hand grabs in flush panels.
11. Flush or recess all knobs, handles, latches, lighting fixtures etc.
12. Secure all portable and fixed equipment to withstand collision forces without tearing loose.
13. Provide closed compartments for passenger luggage.
14. Pad or design for deformation all surfaces subject to impact by rail vehicle occupants.

3. RAIL VEHICLE INJURIOUS ENVIRONMENT

Injuries to rail vehicle occupants during collision or derailment when the rail vehicle remains relatively uncrushed are generally caused by acceleration of the occupant into objects in their immediate vicinity. The degree of injury is dependent upon the velocity of the vehicle at the time of collision, the rigidity or irregular surface of the object struck and the distance thrown to the object struck. Collision velocity, up to a point, affects the acceleration of the occupant within the vehicle but the distance the occupant travels is the principal determinant of impact velocity. The injury mechanisms characteristics of deformability and surface continuity is of particular importance in injury determination.

3.1 RAIL VEHICLE COLLISION DESIGN PULSE

Design of protective devices for occupants of rail vehicles in a collision is dependent upon the deceleration pulse experienced by the vehicle in which they are riding. The magnitude and duration of the pulse varies for different types of rail vehicles such as locomotives, passenger cars and cabooses. The velocity of the car at impact also determines the pulse shape but to a lesser degree.

3.1.1 Freight Locomotive Head-On-Collision Pulse

Plots of deceleration versus time for either of two freight train locomotives in a head-on collision at speeds of 10, 20, 40 and 80 mph are shown in Figure 3-1. Three distinct regions are immediately evident.

The first region is characterized by a rapid rise to a peak followed by a more gentle drop to a plateau. This represents crushing of the locomotive front and rear ends and the front end of the car immediately behind the locomotive. The initial rise is due to buildup of compressive load in the front ends of the locomotives as they collide. The loads quickly reach a maximum value as the front ends start to crush. The following cars, in the meantime, are plowing into the locomotives. The forward push resulting from this tends to relieve the decelerative forces in the front end, and gives rise to the fall-off of deceleration. The peak deceleration is closely approximated by the ratio of locomotive front end crush load to the locomotive mass:

$$\text{peak deceleration} = \frac{\text{front end crush load}}{\text{locomotive mass}}$$

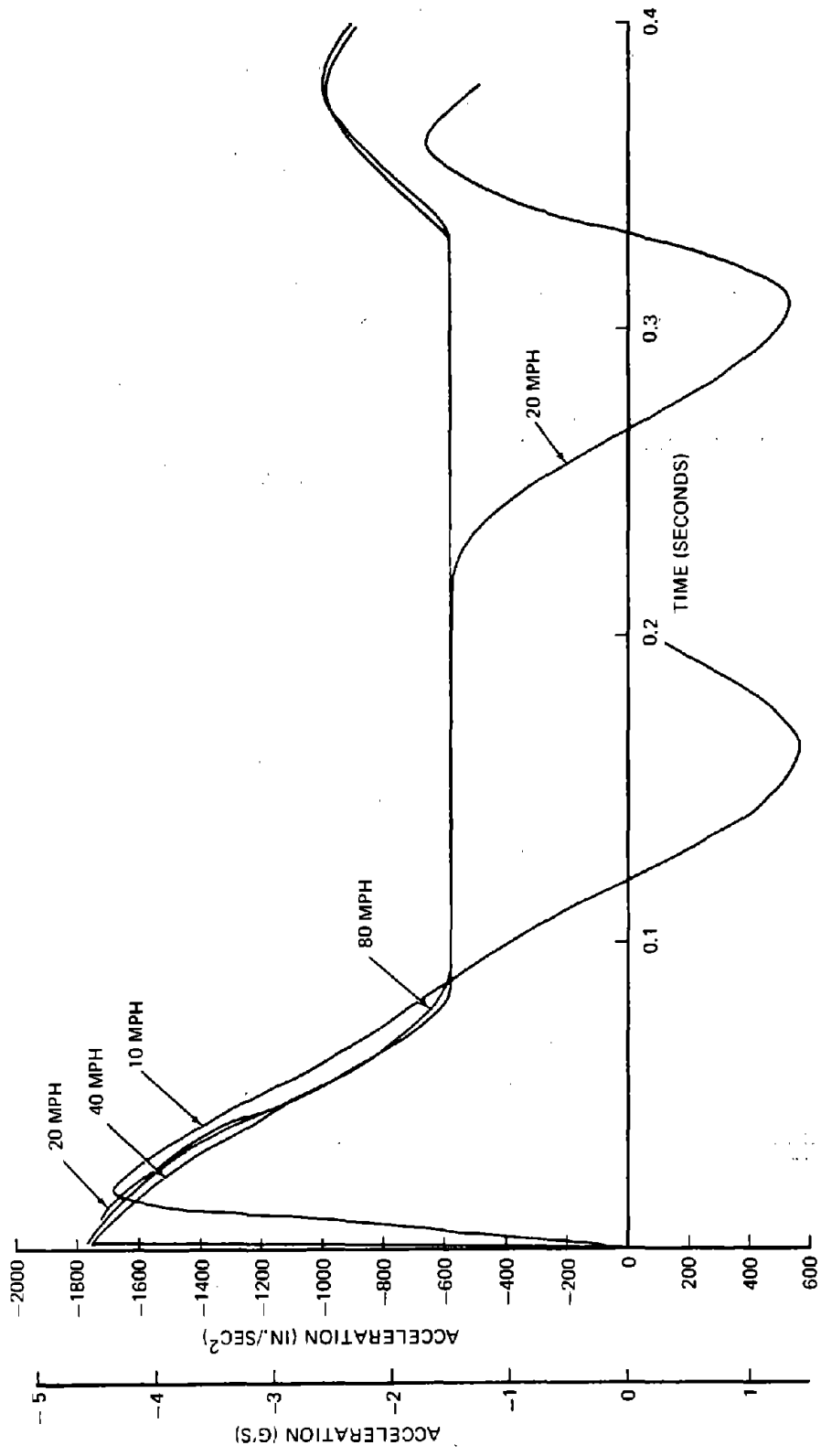

Figure 3-1. Freight Train Locomotives in Head-On Collision: Acceleration vs Time

The second zone develops as the second car plows into the locomotive, the compressive forces developed between the locomotive rear end and the car rapidly leads to crushing of the car front end, accompanied by attenuation of compressive loads. The locomotive then continues to decelerate at a constant rate, given by:

constant deceleration =

$$\frac{(\text{locomotive crush load}) - (\text{second car crush load})}{\text{locomotive mass}}$$

The third zone is initiated by the two locomotives rebounding off each other. Subsequently, a series of rebounds between each locomotive and its following car, as well as between the two locomotives, give rise to an oscillatory response. In practice, these rebounds will be quickly arrested by several mechanisms not included in the analysis, such as structural damping, friction, entanglement of structural components as crushing occurs, and energy dissipation due to pieces of structure being shed off at high velocities.

Figure 3-1 shows plots for 10, 40, and 80 mph contact velocities. Note that except for the 10 mph case, the general characteristics observed at the 20 mph closure speed are repeated at the other speeds.

The peak deceleration is the same in all cases, although the time to peak deceleration decreases with increasing contact speed. The total duration of the first zone, representing the time to initiate structural crushing in the locomotive and the second car, varies little with contact speed above 20 mph. Typically, this lies in the time range of 0.08 to 0.09 seconds.

The duration of the second zone is the period of crushing in the front end of the first car following the locomotive. The end of crushing occurs when either of the two locomotives rebound off each other, as is the case at 20 mph, or when the second car bounces off the locomotive. Figure 3-1 indicates that the duration increases with contact speed.

At low contact velocities, the deceleration-time characteristics, typified by the plot for 10 mph, differs markedly from those discussed above. The peak deceleration at 10 mph is slightly less than at the higher velocities, indicating that crushing of the locomotive does not occur. The system behavior is entirely elastic, comprising a series of rebounds which are quickly arrested by effective damping mechanisms such as those previously noted.

3.1.2 Freight Locomotive and Caboose Rear-End Collision Pulse

For a rear-end collision between two freight trains, Figure 3-2 shows the locomotive deceleration pulses for various closure speeds, and Figure 3-3 shows the corresponding plots for the caboose. The locomotive curves show distinct departures from those observed in the head-on case. This is because crushing occurs in the caboose and the car ahead of it instead of the locomotive and the car behind it. This is borne out by the curves for the caboose, which show the same shapes as in Figure 3-1 except that the plateau of zone two occurs at zero value of deceleration (the caboose and boxcars are assumed to have the same crush load).

3.1.3 Passenger Train Locomotive and Passenger Car Rear-End Collision Pulse

Figure 3-4 shows the deceleration pulses for passenger cars impacted at 10, 20, 40, and 80 mph. The characteristics and mechanics are similar to the preceding collision scenarios.

3.2 INJURY PRODUCING ENVIRONMENT

Accident injury analysis has associated the major causes of injury, other than those related to structural crushing, to environmental factors such as lack of occupant restraint and deficiencies of equipment design and location. To identify potential design improvements, simulated motions of occupants under collision acceleration are presented using typical high usage locomotives, passenger railcars, and cabooses.

3.2.1 Locomotive Occupant Impact Hazards Environment

An EMD GP-40 locomotive cab is shown to illustrate a typical interior arrangement and the potential collision hazards to the trainmen. Two or more trainmen occupy the cab: an engineman/engineer and a helper/fireman. The engineman is particularly vulnerable to injury in a collision due to the equipment directly in front of him into which he could be thrown (Figure 3-5). The principal objects which present hazards to the engineman during a collision are the control console with its rigid surfaces, glass instrument faces and protruding handles. Maintaining a grip on the controls tends to twist the engineman's body as he is thrown forward (Figure 3-6). The sharp edges on the window handle to his right also present a hazard. A heater, although less of a threat is positioned in front of the engineman's legs.

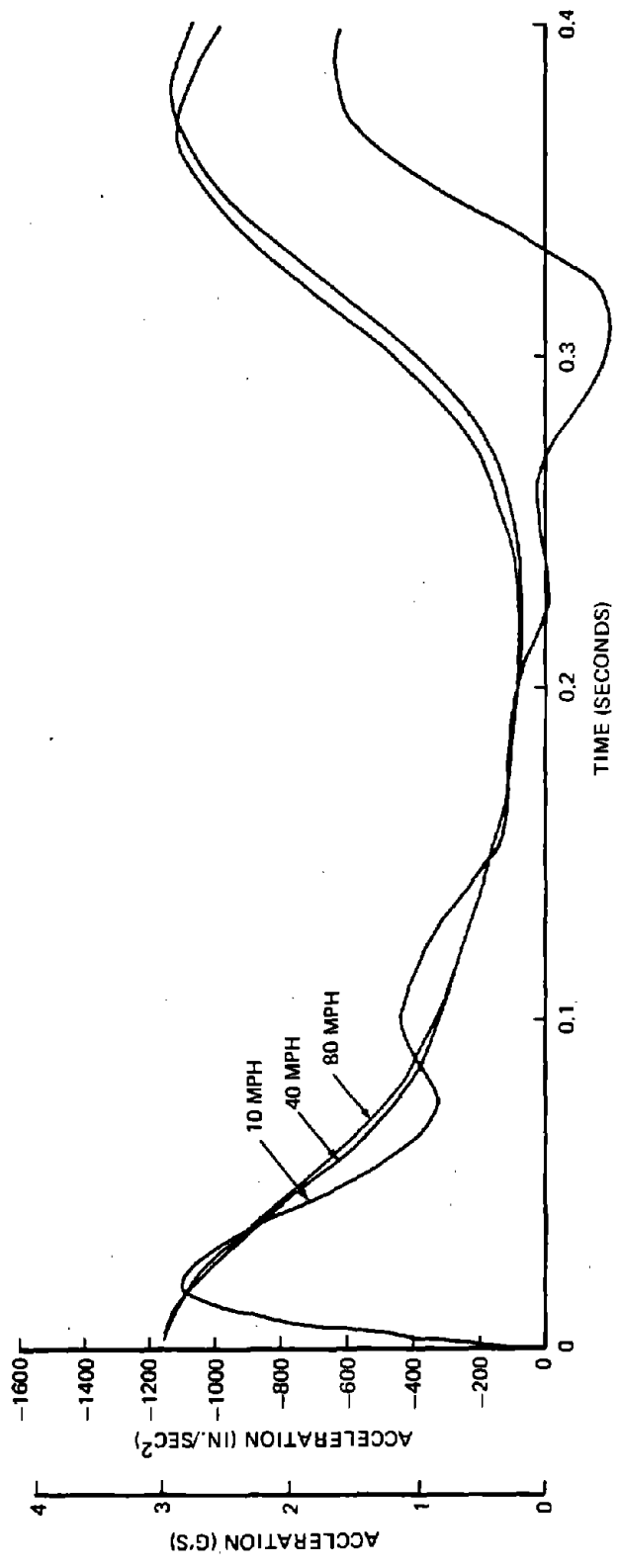
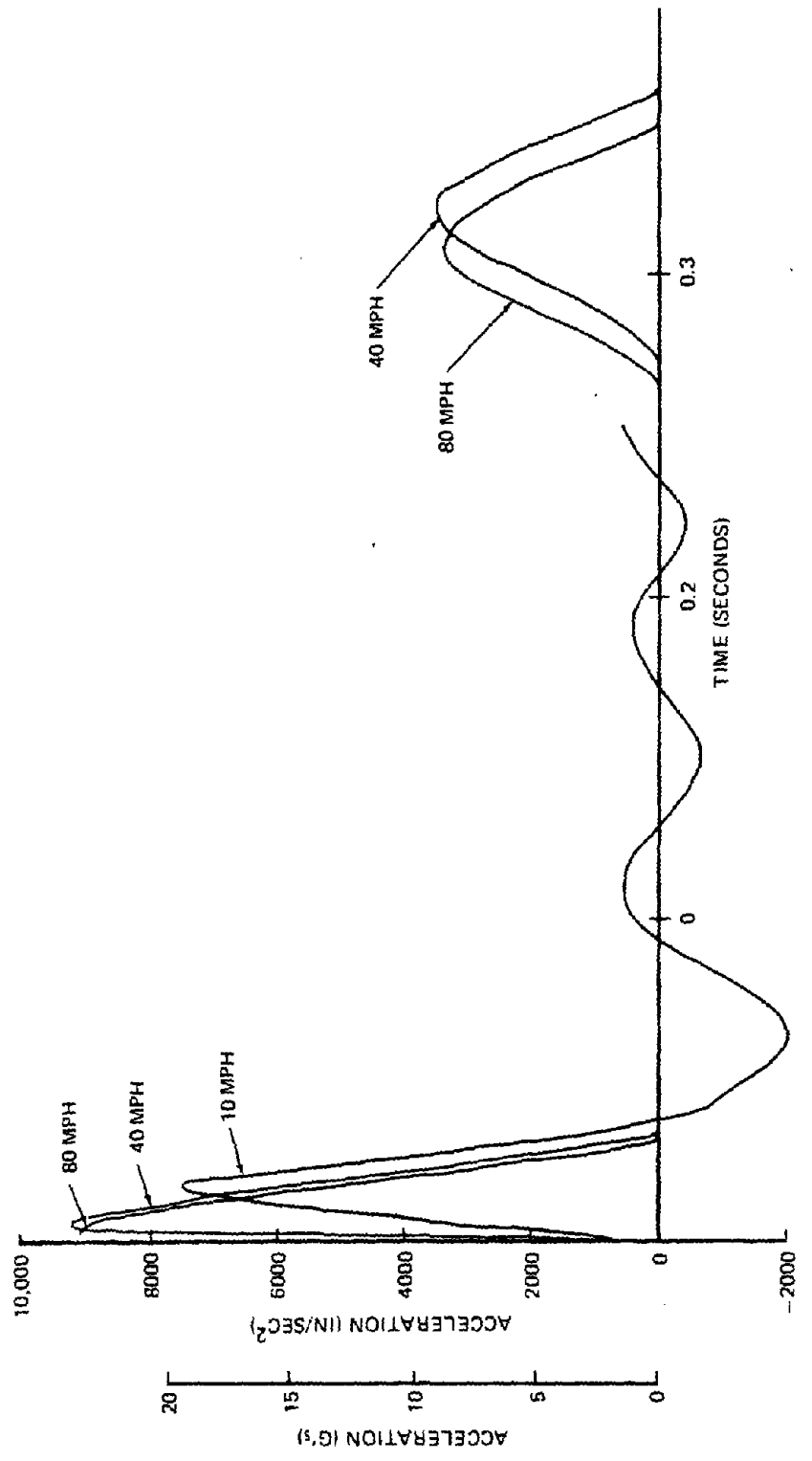

Figure 3-2. Freight Trains in Rear-End Collision: Locomotive Impulse During Collision with Caboose



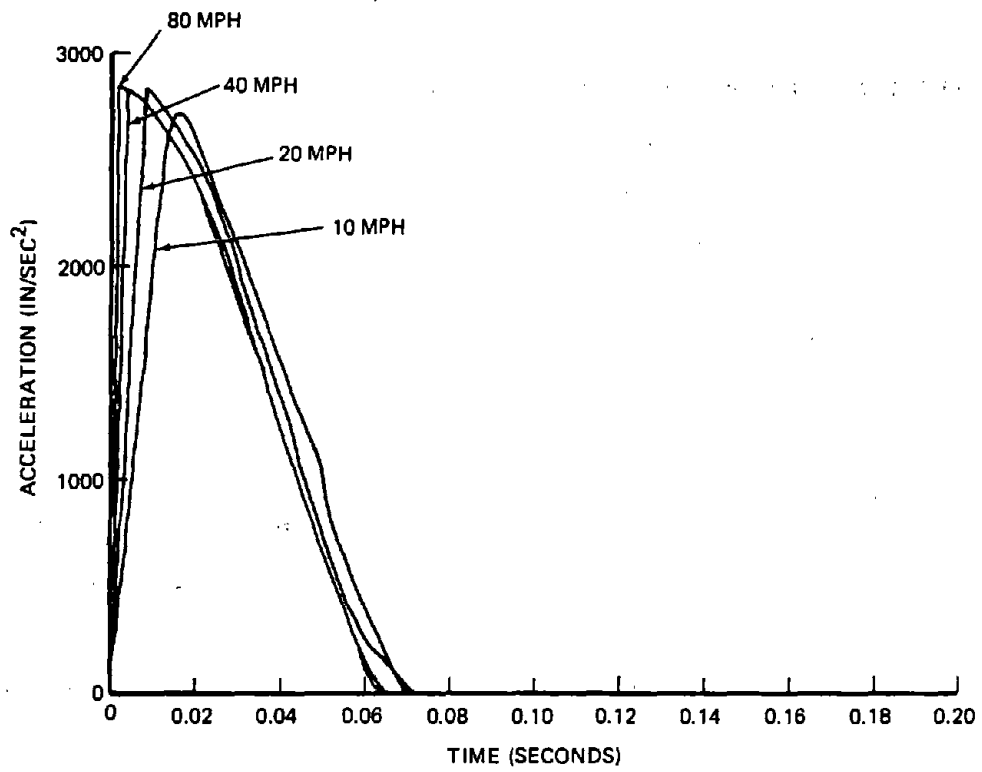

Figure 3-4. Passenger Car Impulse During Impact by Locomotive



Figure 3-5. Potential Hazards to Engineman Impact



Figure 3-6. Engineman Twisted by Forward Impact



Figure 3-7. Forward Acceleration Injury Potential – Fireman

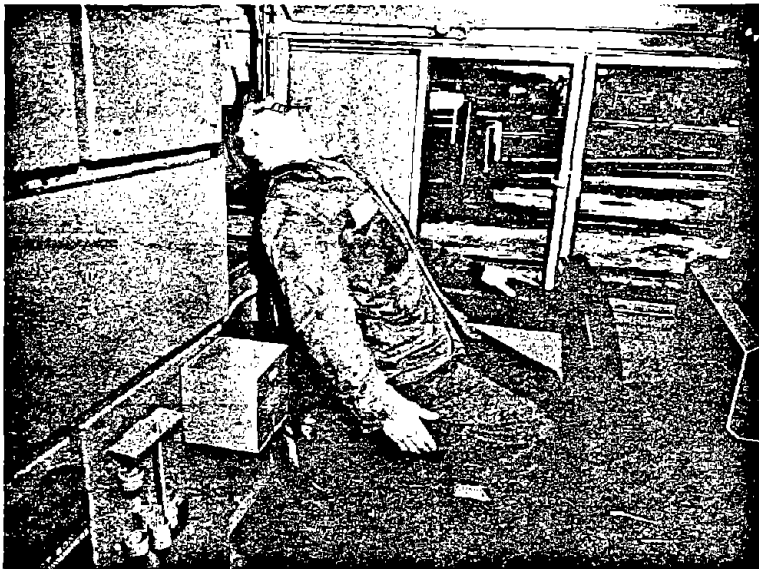

Figure 3-8. Rearward Acceleration Whiplash – Fireman

The locomotive cab space available for the helper and other trainman on the left side, fitted with adjustable swivel seats facing either forward or rearward, is usually clear and unobstructed. The main hazard for the helper is the potential for him to be thrown into the door or into the glass in the door (Figure 3-7). Whiplash is also a potential hazard during rear-end collisions or hard couplings due to the low seat backs (Figure 3-8). Sharp edges at the back end of the arm rest and on the seat back would be a hazard to the rear occupant in a tandem seat arrangement.

Equipment installed in the cab may present an impact hazard to occupants when accelerated from a seated or standing position. Consideration must be given to the placement and configuration of such items as:

Fire extinguishers	Windshield wiper motors
Water coolers	Instruments
Controls consoles	Gages and piping
Circuit breaker panels	Radios and telephones
Door handles and knobs	Heaters and ducts
Piping and valves	Sander control
Footrests	Deadman pedal or bar
Heaters	Handholds
Seats	Windows and armrests
First aid kits	Window latches

3.2.2 Caboose Occupants Impact Hazards Environment

An ICC wide vision cupola type caboose is shown to illustrate a typical interior arrangement and the potential collision hazards to the trainmen. The cupola observation post and the conductor's desk location areas are of particular interest for injury-producing situations.

In the cupola observation post, injury can result to an unrestrained trainman during collision, slack action, or hard coupling by being thrown into the bulkhead, handhold and possibly through the window (Figure 3-9). Injury is also possible by impacting the side wall, window, or guard railing or by falling from the cupola to the car floor during cross collision, derailment, or rollover (Figure 3-10).

Objects which can produce injury due to body contact in the cupola consist of fire extinguishers, sun visors, windshield wipers, grab bar, radio, and footrest. Seats which do not provide headrest restraint can result in whiplash injury during rearward acceleration from collision, slack action, and hard coupling.

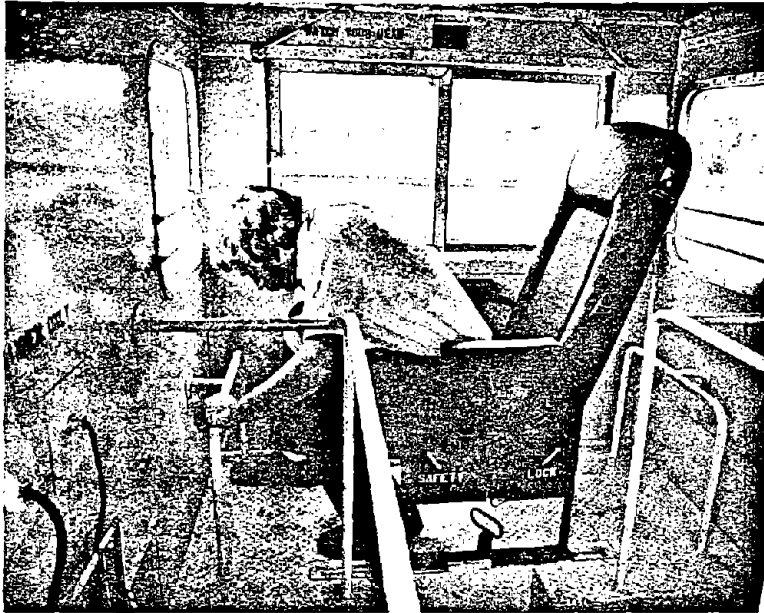

Figure 3-9. Cupola Hazards Under Forward Acceleration



Figure 3-10. Cupola Hazards Under Side Acceleration

The unrestrained conductor seated at his desk could sustain injury by impacting the front and top of the desk, bulkhead, and window (Figures 3-11 and 3-12). If thrown across the aisle he could impact the heater, railing, cooking stove, sink or cabinets.

While equipment varies from car to car, additional injury producing hazards are: fuel tank and bunk supporting structure, water coolers and refrigerators, fire extinguishers, fusee boxes, protruding door handles, grab rails and stanchions, seat frames, record storage racks, lamps, phones, gauges, valves, and foot-rests.

Caboose occupants who are standing or walking are exposed to all of the above hazards, particularly when time does not permit holding onto a door or ceiling grab rail. In the more severe collisions, further hazards exist from seat structure separation or failure, flying water bottles, and other non-stowed equipment (Figure 3-13). The lavatory, while offering body containment, also includes many hazards in the form of wall-mounted cabinets, exposed piping, tanks, windows and hard surface bulkheads (Figure 3-14).

3.2.3 Passenger Railcar Occupant Impact Hazards Environment

Hazards to railcar passengers depend upon their seated or standing environment. Environments differ depending upon the type of car in which the occupant is riding. Three types of passenger cars are presented representing typical environments. Shown are the Metroliner coach, parlor car, and snack bar coach with their seating arrangement, inherent containment provisions, and surfaces or equipment having potential to cause injury if impacted.

3.2.3.1 Coach Car Impact Hazards Environment

In the coach car, an arrangement of 38 double bench seats on each side of a central aisle are used. Each seat bench has three armrests dividing it into two individual seats. The armrests are rigid and unpadded, and are topped with a smooth plastic cap. The seat backs are the high headrest type which recline individually. The seat pair swiveles over a rigid frame providing either forward, rearward, or face-to-face seating.

In the coach car, passengers are contained during rearward or forward accelerations by their seat back and the seat back or bulkhead ahead of them. Injuries due to impact with these surfaces could occur if these surfaces lacked sufficient energy absorbing characteristics. Typical areas of impact into an upright seat back under forward acceleration are the head,

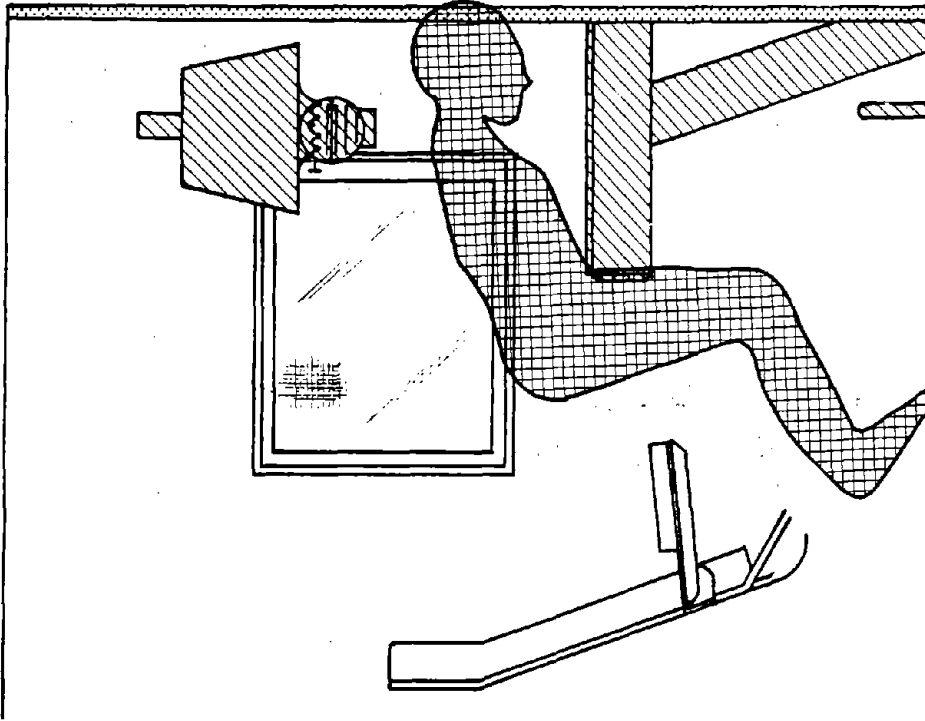

Figure 3-12. Conductor Without Restraint



Figure 3-11. Conductor Impacting Desk Under Forward Acceleration

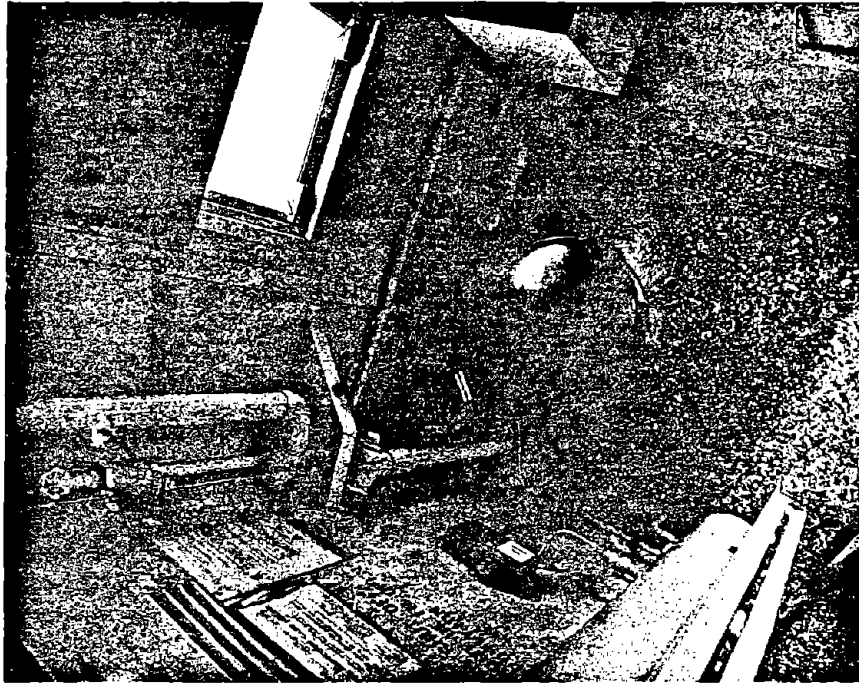

Figure 3-14. Caboose Lavatory Hazards

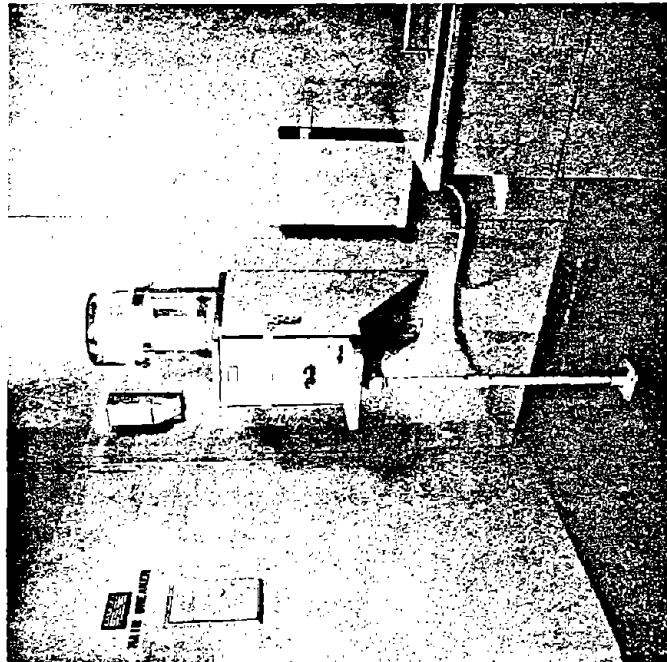

Figure 3-13. Caboose Equipment Hazards

face, legs, and arms (Figure 3-15). Sliding of the leg under the seat can produce concentrated bending loads applied to the tibia as the legs become jammed under the seat due to a forward acceleration (Figure 3-15). With the coach seat in the reclined position, additional injuries may be imparted to the chin, neck, and possibly the thorax, particularly if a rigid hand grab is included on the seat back.

Injuries may be produced in the upper torso, knee-thigh-complex, the back, or the head from being pitched into an unyielding bulkhead several feet from the seated passenger (Figure 3-15). Additional localized head and facial injuries could be imposed by the presence of a nonyielding magazine or display rack. Rotation of seats to a face-to-face position produces potential for injury when the rear passengers are hurled into the forward passengers (Figure 3-15).

A seated passenger may suffer hyperextension of the neck in a rear-end collision if a low seat back is used or when the body is not completely in the seat during the collision and becomes skewed. Side flexion and possible ribcage damage can occur from the seat armrest due to a severe side thrust or rollover of the car. Rollover can throw the occupant up from the seat causing the head to contact the baggage rack and the shoulder the upper window sill (Figure 3-16). Derailment or jackknifing can exert lateral accelerations to cause impact of the shoulder against the car side and the head against the window (Figure 3-17). Lateral sway, derailment or rollover would pitch a standee about the armrest with possible impact of the head against the window (Figure 3-18). A standee in the washroom could be thrown against the mirror and if seated could strike their head on the sink (Figure 3-19).

3.2.3.2 Parlor Car Impact Hazards Environment

The parlor car contains 38 seats in a low-density arrangement with a single row of seats on either side of the aisle. Adjacent to each seat is a fold-down desk cantilevered from the side wall. Each seat has thickly padded armrests and a reclining high seat back with a concave cushioned head rest. The seat also has a full swiveling feature which permits omnidirectional use during transit.

Containment is less likely in the parlor car than in the coach. Seats may be oriented in any position of their 360-degree rotational capability. The problem associated with face-to-face seating is present. Leg entrapment in face-to-back positions will also occur (Figure 3-20). One mitigating circumstance which may eliminate some of these problems, for seats positioned in a direction other than the direction of impact, is the seats capability to rotate. The center of gravity of the occupant is behind the swivel point and a



LEG ENTRAPMENT



INTO RECLINED SEAT

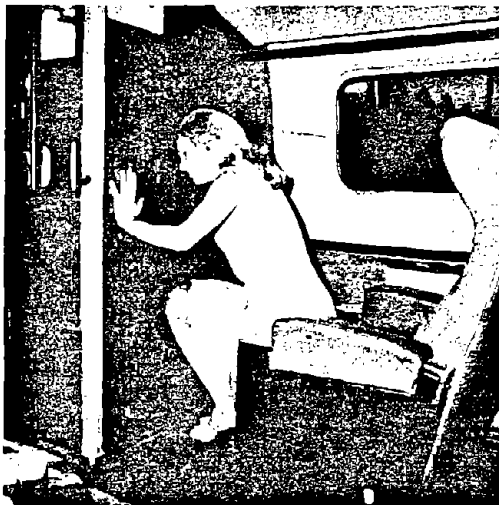

INTO BULKHEAD



FACE-TO-FACE SEATING

Figure 3-15. Injuries from Forward Acceleration – Passenger Railcar



Figure 3-16. Rollover Impact



Figure 3-17. Impact with Window



Figure 3-18. Lateral Sway



Figure 3-19. Longitudinal Acceleration – Passenger Lavatory

collision acceleration will tend to rotate the seat back in the direction of the acceleration. Provided the seat back will withstand the collision forces, this is the best direction for the occupant to be facing.

An occupant leaning over the desk would not be afforded this protection. A lateral load would cause abdominal impact with the desk, and head impact with the window (Figure 3-21). A seat facing rearward in a rear-end collision could cause an occupant to be thrust into the desk to the rear (Figure 3-22).

The larger aisle and smaller number of seats permits the standee to be closer to and more accessible to the baggage rack and more liable to impact due to lateral accelerations. The rack edge, if unpaddinged, could produce head injury (Figure 3-23).

3.2.3.3 Snack Bar Coach Impact Hazards Environment

In the snack bar coach, the same density of seating is used as in the coach. However, only 60 seats are available. The balance of the car space is devoted to a snack bar. This is a partitioned section in the center of the car with two smooth metal edged counters, one for food preparation and the other for standup eating.

Potential injury-producing circumstances would be the same in the coach portion as in a standard coach car. The snack bar is the only new area of consideration and this is confined to standee passengers. In lateral accelerations during derailment, jackknifing, or rollover, passengers standing at the bar could be thrown backwards over the counter or head first over the bar (Figure 3-24).

A partial partition with a transparent plastic panel insert is located at each end of the snack bar area. Longitudinal or lateral accelerations causing impact with the rigid partition or with its sharp corners could produce injury (Figure 3-25). The partition would, however, limit the distance a standee at the counter would be thrown in a longitudinal collision.

The food preparation area of the snack bar presents many sharp edges and much protruding hardware, which could produce injury upon impact (Figure 3-26).

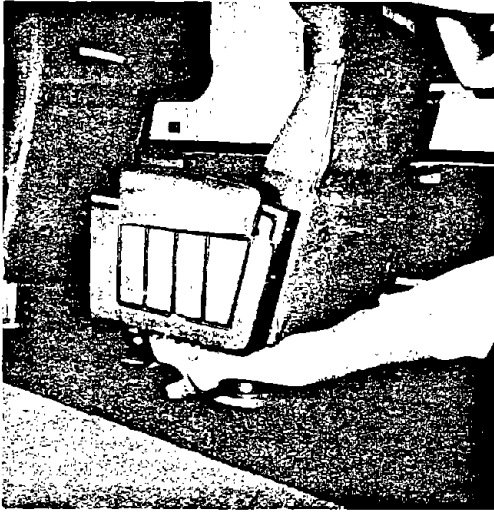

Figure 3-20. Leg Entrapment



Figure 3-21. Lateral Impact



Figure 3-22. Longitudinal Impact



Figure 3-23. Lateral Sway



SNACK BAR COUNTER



SNACK BAR

Figure 3-24. Lateral Acceleration Injury Potential

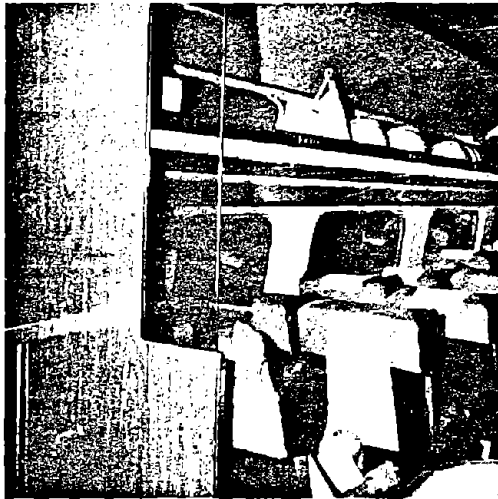

Figure 3-25. Snack Bar Partition



Figure 3-26. Snack Bar Appliances

4. HUMAN TOLERANCE DATA

Human tolerance to impact is difficult to establish because of the obvious impracticability of subjecting humans to impact at injury levels. Much of the data presented is a result of tests conducted with cadavers and minimum forces to produce fractures are documented. Designs for rail vehicle occupant protection in a collision must be for levels considerably below the fracture level. Where data was not available in establishing the non-injury or minor injury levels, an arbitrary force of 10 to 25 percent of the minimum fracture level is given as a design goal depending upon the vulnerability of the body parts. Human tolerance data on the more vulnerable parts of the human body are discussed. Terms used in the discussion are explained in Table 4-1 and a summary of the data is shown in Table 4-2.

4.1. HEAD IMPACT

- Injury Type: brain injury, skull fracture, and/or scalp laceration

Head injury is considered to be injury to the skull, scalp, and/or brain and does not include the facial injury.

Melvin and Evans¹ summarized the fracture forces from different investigators with a skull fracture range of 500 to 2200 pounds depending upon the impact conditions. A small area of impact resulted in the 500-pound fracture level while a 2200-pound fracture force resulted from a large area impact without padding. A flat surface impact to the frontal bone with approximately 3/4 inch of paddings shows no fracture at forces up to 2640 pounds.

Nahum² quotes a minimum fracture force of 900 pounds and average of 1100 pounds from impact to the frontal bone with

1. Melvin, J.W., and Evans, F.G., "A Strain Energy Approach to the Mechanics of Skull Fracture", Proceedings of the Fifteenth Stapp Car Crash Conference, November, 1971, SAE No. 710871.
2. Nahum, A.M., Gatts, J.D., Gadd, C.W., and Danforth, J., "Impact Tolerance of the Skull and Face," Proceedings of Twelfth Stapp Car Crash Conference, October, 1968, SAE Paper No. 680785.

TABLE 4-1. INJURY TERMS

AIS	Abbreviated Injury Scale; zero to nine (fatal)
AP Mandible	Anterior posterior on jaw
Basil	Base
Caudal	Posteriorly (opposed to cephalad)
Caudal Cephalad Direction	Loads transmitted vertically through the spine
Caudal Cephalad Loading	Vertically along the spine
Cephalad	Anterior part of body (opposed to caudal)
Cervical Vertebra	The seven vertebra in the neck region
Coccyx	A small bone at the lower end of the vertebral column
Condyles	Ball and socket joints
Contusion	Injury in which skin is not broken
Distal	Terminal
Dorsal	Of, on or near the back
Femur	Thigh bone
Fibula	Leg calf bone
Frontal Bone	Convex front portion of skull
GSI	Gadd Severity Index
HIC	Head Injury Criteria
Hyperextension	Extreme rearward rotation of head
Hyperflexion	Head striking chest
Ilium	Upper portion of the hip bone
Intervertebral Discs	Elastic discs interposed between the centra of adjoining vertebrae
Ischia	Lower portion of the hip bone
Laceration	Jaggedly torn flesh
Lateral Mandible	Sideways on Jaw
Ligaments	Tissue connecting the bones
Lumbar	Lower part of the back
Mandible	The jaw
Maxilla	Jaw bone
Occipital	Posterior part of the skull bone
Patella	The knee cap
Pelvis	A basin like cavity formed by a ring of bones supporting the spine
Sternum	The breastbone
Tibia	The lower leg (shin) bone
Thorax	The chest (between the neck and abdomen)
Torso	The trunk of the human body
Vertebra	The articulating bones of the spinal column
Viscera	The inner parts of the body especially of the thorax and abdomen
Zygoma	The anterior portion of the upper jaw bone

TABLE 4-2. HUMAN LOADING TOLERANCES

Condition	Minimum Fracture Force - lb	Design Load Limit Goal - lbs Rail Vehicle Occupants	Design Load Limit Goal - lbs/in. ² Rail Vehicle Occupants
Flat Surface to Head 6 in. ²	2200	550	90
1 in. ² Object to Head	500	50	50
5/8 in. Diameter Rod to Head	700	70	46
1 in. Diameter to Face Bone (Zygoma)	180	20	25
5.2 in. ² to Face Bone (Zygoma)	360	90	20
Nose Impact	<100	10	10
Chin Lips	-	40	20
Knee-Thigh-Hip Complex	1700	450	75
Concentrated Load on Leg (Tibia)	225	25	-
Concentrated Load on Arm	225	55	-
Vertical Load on Dorsal or Lumbar Intervertebral Discs	600	150	-
Chest, Rib (Thorax) Impact 6 in. Diameter Area	800	280	10 to 40

a one-square-inch impactor. Hodgson et al³ reported on impacting cadavers with 5.8 dia. steel cylinders. The average fracture level was 1250 pounds with a range of 700 to 1730 pounds.

Using padded surfaces designed for a three-inch decelerating distance from a head impact of 20 mph, the head acceleration should not exceed 80 g's and the HIC will be approximately 400. No brain injury or skull fracture should result but soft tissue or scalp injury can result with perhaps a bruise.

4.2 FACE IMPACTS

- Injury Type: Facial bone fracture, soft tissue injury and eye injury

Facial bone fractures are sensitive to the area and hardness of the impactor. The minimum force levels as recommended by Schneider⁴ and Nahum² are based upon an impact by a one-inch diameter impactor. With such a small impactor the force is concentrated on the bone in question. If the impact is to a large padded surface, the force is distributed over several facial bones and the tolerance level increases dramatically. For example, the minimum fracture level, as reported by Hodgson⁵, for impact to the Zygoma is 360 pounds or almost twice that reported by Schneider. Hodgson used an impactor of 5.2 square inches covered with a one-inch urethane pad. Similarly, the mandible fracture level was considerably higher with the padded impactor.

Injuries to soft tissues can occur from impacting glass⁶, small knobs, or hard surfaces, where the injury appears as a

3. Hodgson, V.R., Brinn, J., Thomas, L.M., and Greenberg, S.W., "Fracture Behavior of the Skull Frontal Bone Against Cylindrical Surfaces," Proceedings of the Fourteenth Stapp Car Crash Conference, November, 1970, SAE Paper No. 700909.
4. Schneider, D.C., and Nahum, A.M., "Impact Studies of Facial Bones and Skull," Proceedings of the Sixteenth Stapp Car Crash Conference, Detroit, Michigan, November, 1972.
5. Hodgson, V.R., "Tolerance of the Facial Bones to Impact," The American Journal of Anatomy, Dempster Memorial Issue, Vol. 120, No. 1, pp. 113-122, January, 1967.
6. Patrick, L.M., Lange, W.A., and Hodgson, V.R., "Facial Injuries - Causes and Prevention," Proceedings of the Seventh Stapp Car Crash Conference, Charles C. Thomas, Springfield, Illinois, 1965.

laceration but is actually a compression or explosion type of injury. Soft tissue injury to the upper lip, nose, and chin can be eliminated by adequate padding to distribute the force, especially over the facial bones.

Fracture of the nose occurs at low levels. A very soft padding of one inch or more in thickness over firmer padding will protect the nose by permitting the nose to sink into the soft padding and the major force then to be taken on other parts of the face.

4.3 KNEE-THIGH-HIP COMPLEX IMPACT

- Injury Type: Fracture of the patella, fracture of the femur, fracture of the pelvis, and/or joint injury.

Knee impact limitations are set at 1700 pounds in MVSS 208. Data generated by Patrick resulted in femur load limitations of 2000 pounds. Patrick^{7,8} reports on impacts to a rigid padded surface with cadavers in a normal seated position. The load cells measured the force at the knee. Since the intact cadaver was used, the force applied to the knee could result in fracture to the patella, femur and/or pelvis. With loads of 1800 to 2000 pounds, fractures can occur in some individuals from knee impact.

4.4 FLEXION OR EXTENSION NECK INJURIES

- Injury Type: Soft tissue, cervical vertebra fracture or basilar skull fracture.

Research has shown that the torque at the occipital condyles is the best measure of injury potential as a result of

7. Patrick, L.M., and Mertz, H.J., "Cadaver Knee, Chest and Head Impact Loads," Proceedings of the Eleventh Stapp Car Crash Conference, October, 1967, Anaheim, California, SAE Paper No. 670913.
8. Patrick, L.M., Kroell, C.K., and Mertz, H.J., "Forces on the Human Body in Simulated Crashes," Proceedings of the Ninth Stapp Car Crash Conference, Nolte Center for Continuing Education, University of Minnesota, 1966.

inertia loading in flexion or extension.^{9,10,11} In addition to the torque from the inertial loading, there is a shear and axial load applied at the occipital condyles. Experimental results indicate that these loads are well below the voluntary static limit when the torque exceeds the injury limit. Therefore, the shear and axial load under inertial loading conditions are not limiting factors.

During the extension of the head and neck during inertia loading (the so-called whiplash syndrome), soft tissue is injured more often than bone. Ligaments, muscles, and complex tissue attachments between the cervical vertebra are vulnerable to injury. Experimental programs with volunteers and cadavers indicate that there are no injuries until the angle between the head and neck reaches or exceeds a critical value. Consequently, hyperextension and hyperflexion injuries can be avoided by providing a suitable support to keep the head from rotating more than a predetermined amount with respect to the torso. The limiting angle appears to be approximately 80 degrees between the head and the torso, measuring from the normal head position.

4.5 FLAILING LIMBS

- Injury Types: Fracture of the long bones of the arm and legs and injury to joints.

Kramer¹² conducted tests on the lower limbs of 200 cadavers using a pendulum consisting of cylinders 5.7 or 8.5 inches in diameter. The forces measured ranged from 225 to 1330 pounds at fracture. The impact site varied from just below the knee to the distal end of the tibia. The maximum values were lower for females than for males.

9. Mertz, H.J., "The Kinematics and Kinetics of Whiplash," Ph.D. Dissertation, Wayne State University, 1967.
10. Mertz, H.J., and Patrick, L.M., "Investigation of the Kinematics and Kinetics of Whiplash," Proceedings of the Eleventh Stapp Car Crash Conference, Society of Automotive Engineers, Inc., New York, 1967.
11. Mertz, J.J., and Patrick, L.M., "Strength and Response of the Human Neck, : Fifteenth Stapp Car Crash Conference Coronada, California, November 17-19, 1971, SAE Paper No. 710020.
12. Kramer, M., Burow, K., and Heger, A., "Fracture Mechanism of Lower Legs Under Impact Load, : Proceedings of Seventeenth Stapp Car Crash Conference, November 12-13, Oklahoma City, Oklahoma, SAE Paper No. 730966.

Young¹³ found a range of 1000 to 1500 pounds when impacting the tibia at the distal third. His value corresponds to the upper end of the fracture range found by Kramer¹².

Flailing limbs coming in contact with a hard surface that concentrates the force near the center of the long bone will produce bending plus concentrated loads at the point of impact. When the force exceeds the fracture level, including the effect of the concentrated load on the bone, fractures will occur. Fracture in bending of the long bones of the arm is approximately as low as 225 pounds. The danger of fracture can be reduced by distributing the force over a substantial length of the bone and by padding the contact areas to avoid the concentrated loads at point of contact.

4.6 THORAX IMPACT

- Injury Types: Injuries to the thorax include rib fractures, sternal fractures, and thoracic viscera injuries.

The human tolerance to chest impact is dependent upon the area of contact. Patrick⁷ reports approximately 1000 pounds for rib fracture from impact to a 6-inch diameter padded target. Kroell¹⁴ reports about 800 pounds as the fracture level with a 6-inch diameter unpadded impactor. Kroell further notes that force is not as good a criterion as deflection of the chest for indicating injury potential. If the force is distributed over a substantial part of the thorax the recommended loading shall not exceed 40 g's continuously for more than 3 milliseconds.¹⁵

13. Young, J.W., "Threshold Value for Tibia Fracture, Male Cadavers (aged 29-57)," 1967 (unpublished).
14. Kroell, C.H., Schneider, D.C., and Nahum, A.M., "Impact Tolerance and Response of the Human Thorax II," Proceedings of Eighteenth Stapp Car Crash Conference, Ann Arbor, Michigan, December 4-5, 1974, SAE Paper No. 741187.
15. Title 49, Code of Federal Regulations Part 571.201, Occupant Protection in Interior Impacts, Motor Vehicle Safety Standards, National Highway Traffic Safety Administration, Department of Transportation, Washington, D.C.

5. PROTECTIVE DESIGN CONSIDERATIONS

5.1 GENERAL CONSIDERATIONS

In designing rail vehicle interiors for occupant safety and collision protection the assumption must be made that the structure surrounding occupiable areas remains reasonably intact, without significantly reducing occupant living space. If occupants are injured during a collision because the protective shell around them is crushed, efforts to improve survivability through methods such as occupant containment and delethalization are of little use. Design requirements for the minimization of rail vehicle structural crushing are discussed in a separate document TSC-856-3.

In the design of rail vehicle interiors for crashworthiness the following injury-prevention measures must be considered in conjunction with the various types of vehicle responses to optimize occupant safety environments:

- Provide occupant restraint or containment
- Provide crashworthy seating
- Delethalize occupant environment
- Adequately secure interior objects and equipment
- Employ flame-retardant and antitoxant materials

5.2 OCCUPANT RESTRAINT AND CONTAINMENT

To minimize railcar occupant injury it is essential to protect the occupant in his seated area and to prevent contact with hostile surfaces within this area. Many types of protective systems can be considered, both active and passive. Selection of a system will depend upon the proximity of hazardous equipment in relation to the occupant, the effect of the system on the occupant's ability to perform his duties, the cost of the protective system, and the probability of the system being used by the occupant if it requires a willful effort for use.

In selecting a system for containment of a rail vehicle occupant the designer should first consider the immediate seated environment. Maximum containment use should be made of the object or structure behind which the occupant is seated. Treatment of these surfaces to present a noninjurious impact

surface should be a prime consideration. Such a passive system requiring no effort for use on the part of the occupant should be a first preference in system selection provided that in the case of a trainman it does not interfere with the train operation and it is economically reasonable. Active restraining devices, though the least costly, should be limited to use by trainmen and should not be considered for passenger use.

5.2.1 Active Restraint Systems

Active restraints are those which must be willfully applied. The forms of basic active restraints are: lap belt only, single diagonal shoulder strap, and shoulder harness. The lap belt only is typical of those used for passengers in commercial aircraft. The diagonal shoulder strap and lap belt system is widely used in highway vehicles and the double shoulder strap system is used for pilots of military aircraft. Each type has application for rail vehicle use.

Variations can be made to the three basic restraint systems.¹⁶ A shoulder harness of double or single straps can be continuous with the lap belt or can be independent of the lap belt. Additions can be made to the basic double shoulder strap system by adding bias straps to improve lateral restraint.

The following restraint combinations, derived from the basic restraint forms, are shown in Figure 5-1.

1. Lap belt only
2. Continuous lap belt and diagonal shoulder strap
3. Continuous lap belt and double shoulder straps
4. Individual double shoulder straps and lap belt
5. Individual diagonal shoulder strap and lap belt

When properly installed, the lap belt restrains the body for forward accelerations at the body's strongest structural elements, and reasonably close to the total body center of gravity. To be effective a lap belt only system must be properly installed or transverse fracture of the vertebral body can occur (Figure 5-2). The anchor points must not be located too high or too far back. Proper installation is shown in Figure 5-2. Adequate clearance ahead of the occupant must be

16. Reilly, M.J., "CRASHWORTHY TROOP SEAT INVESTIGATION", The Boeing Vertol Company, Technical Report 74-93, U.S. Army Air Mobility Research and Development Laboratory, Fort Eustis, Virginia, 23604, December 1974.

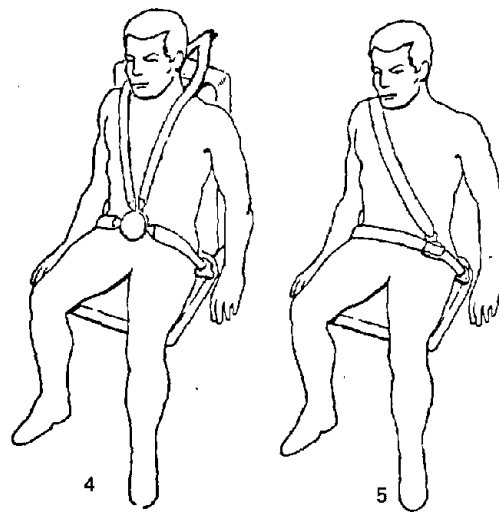
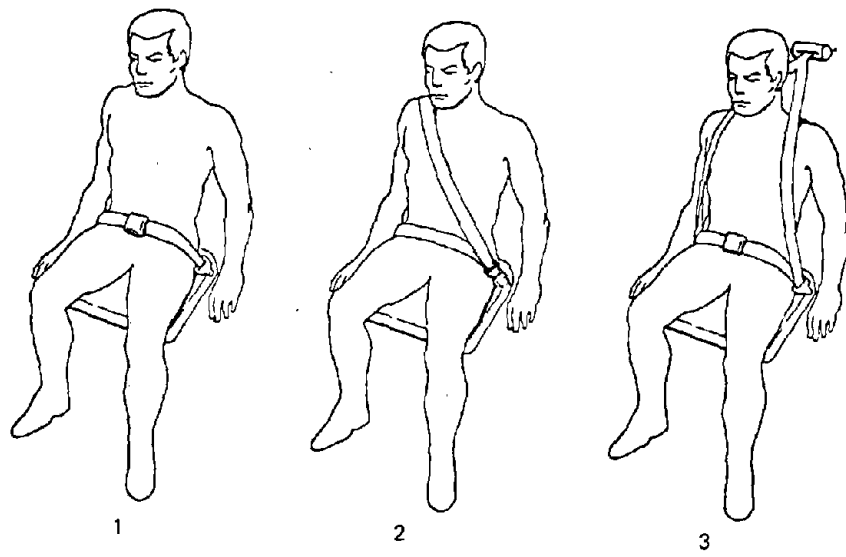
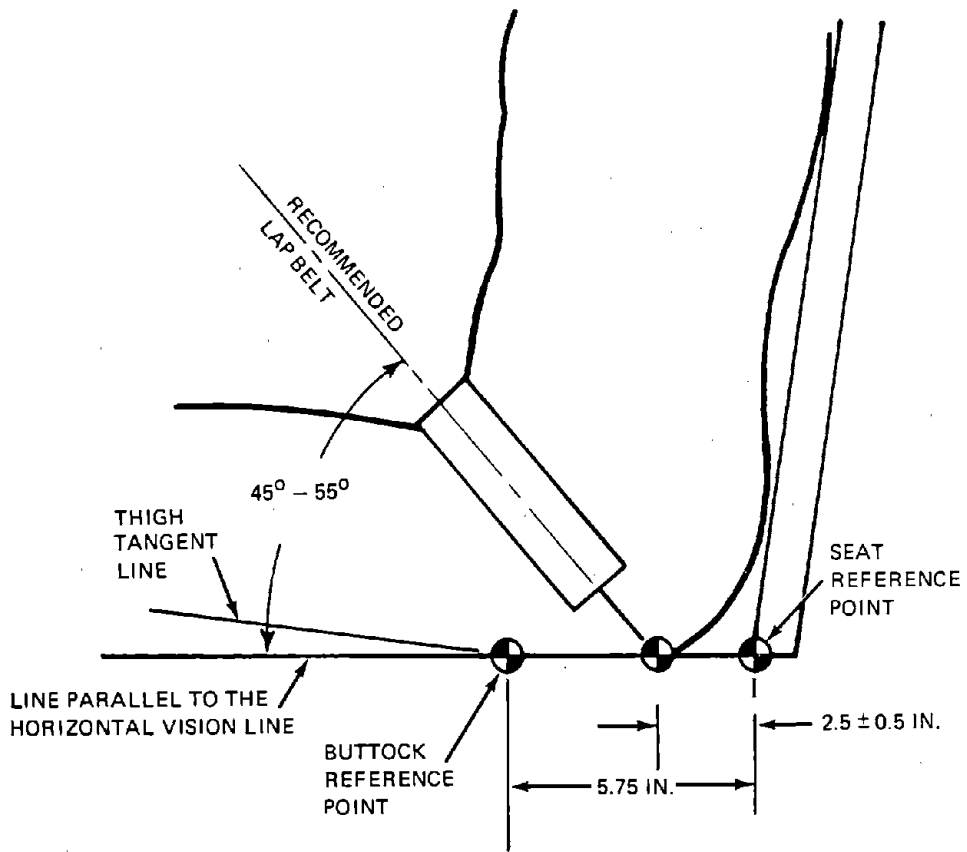
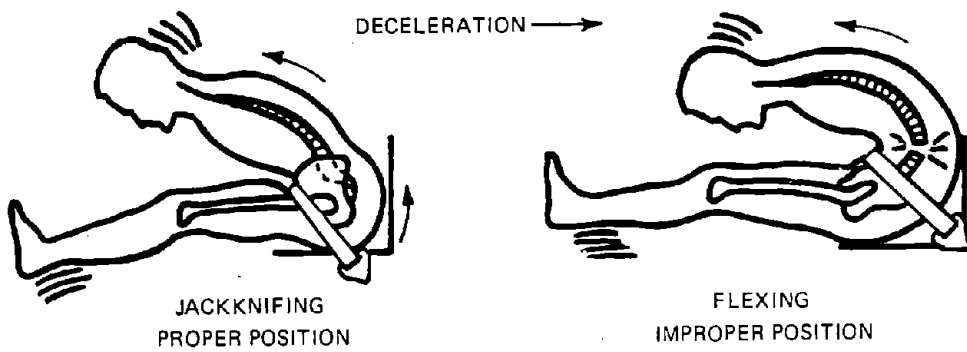

Figure 5-1. Restraint System Concepts



SOURCE: REFERENCE 24

Figure 5-2. Lap Belt Anchorage Geometry

available when selecting the lap belt only system. If such clearance is not available then a single or double shoulder strap system should be selected for use in conjunction with the lap belt.

5.2.1.1 Locomotive Trainmen Active Restraint Systems

A lap belt system can be considered for restraining locomotive enginemen, however, the rotational envelope of the engineman during a collision must be checked for clearance with controls, structure and furnishings in his vicinity.

When using a lap belt alone, for example, the body jackknives in the seat, exposing the upper torso and head to strikes within the rotational envelope.¹⁷ The plan and elevation views in Figure 5-3 show the locomotive engineer in a typical environment and define the strike envelope in which placement of equipment can result in injuries. The most serious threat is to the head, face, and chest, from impact with the console, heater, and to a lesser extent, the window frame and sash. Strikes of limb extremities with such items as the window latch, heater, and control console must be checked.

A lap belt used by a locomotive engineman in a typical EMD cab does not interfere with normal work functions in any seat position. However, simulated forward impact conditions with the lap belt (Figure 5-4) show the engineman's upper torso pitching forward and rotating into the controls. Head and thorax injuries can result from these impacts.

With adequate rotational clearance, use of lap restraint by the helper can eliminate forward impact injury. If a tandem seat arrangement is used, the rear seat occupant with lap belt must have adequate clearance with the forward seat. Seat spacing should be 34 inches between seats or the forward seat back must have adequate padding. Similarly, clearance ahead of the forward seat is essential in avoiding impact with the door and bulkhead during forward accelerations (Figure 5-5). Where tandem seat arrays do not have adequate seat-to-back and/or seat-to-bulkhead clearance, an alternate arrangement could be to use a side-by-side auxiliary seat beside the helpers. Additional considerations to permit the helper to use only a lap belt are to provide adequate padding on the door.

17. CRASH SURVIVAL DESIGN GUIDE, DYNAMIC SCIENCE, USAAMRDL Technical Report 71-22, U.S. Army Air Mobility Research and Development Laboratory, Fort Eustis, Virginia, 23604, October, 1971.

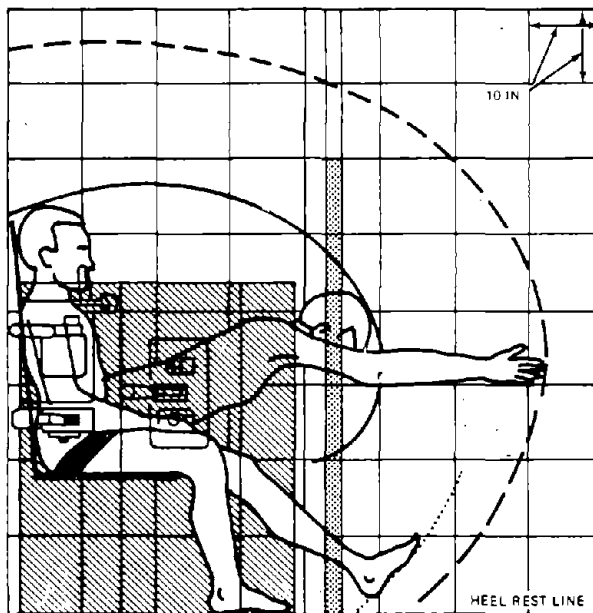
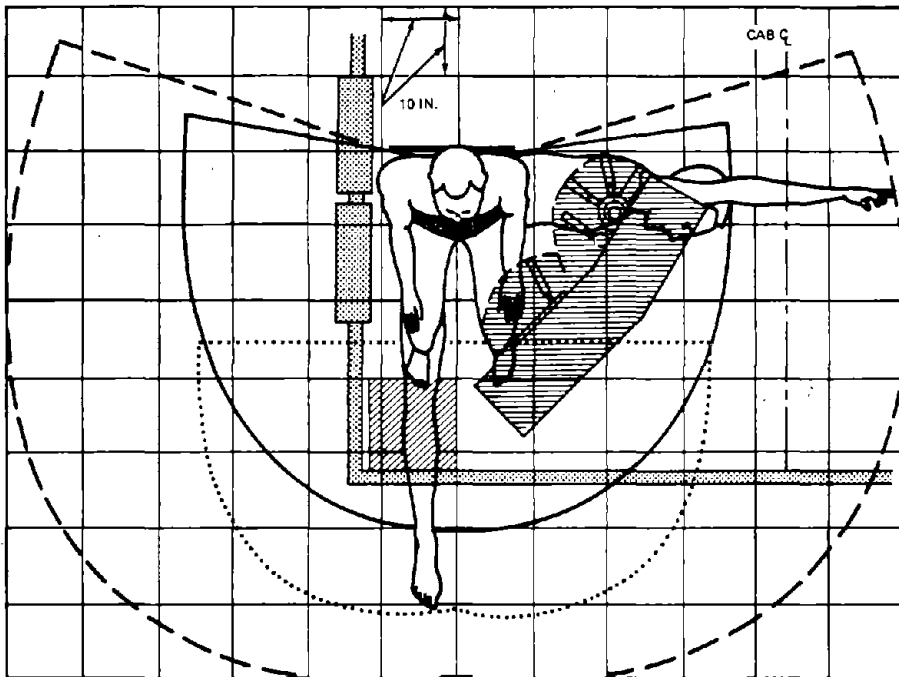

Figure 5-3. Engineerman Rotational Envelope with Lap Belt

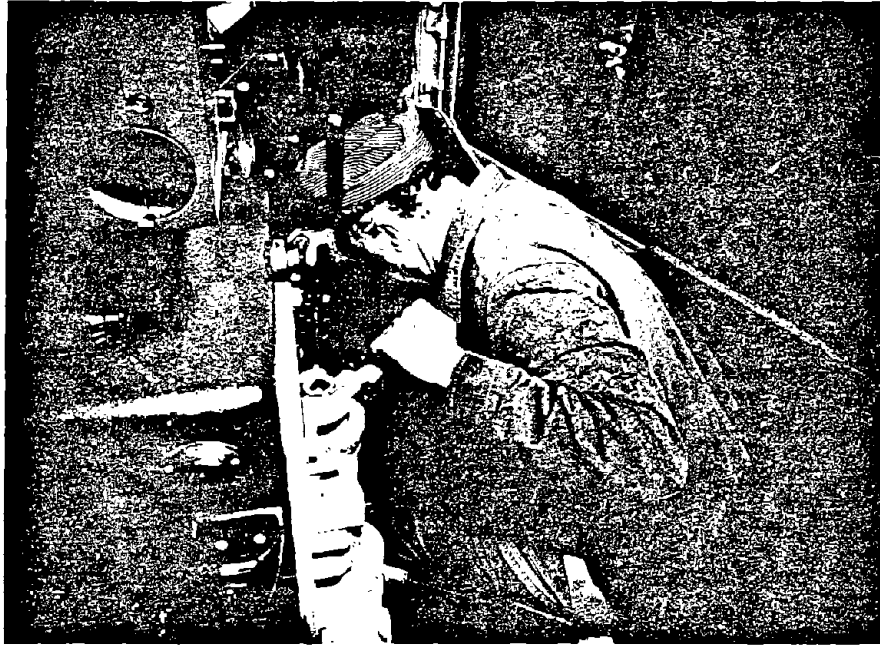

Figure 5-4. Engineman Impact with Console



Figure 5-5. Helper Impact with Door

Application of upper and lower torso restraint for the engineman reduces the strike envelope to 15 percent of that possible with a lap belt alone (Figure 5-6). Operation of the controls are not encumbered by wearing the system, and head and torso contact with the controls and side window are eliminated (Figure 5-7). Similar protection is afforded the helper. Impact with the door (Figure 5-8) and with the cab side and side window are eliminated. Arm flailing under impact loads is reduced approximately 30 percent with the full restraint. A high back seat would be necessary for mounting the shoulder harness. It is important, however, that the shoulder strap be attached to the seat at the shoulder level (26 inches above seat reference point). Attachment above this level permits upper torso rotation within the strap; attachment too low causes excessive loads on the shoulder.¹⁶

Use of a shoulder strap reduces the strike envelope and permits placement of hazardous items closer to the occupant. However, the single diagonal strap provides lateral restraint to only one side. The double shoulder strap with lap belt provides full torso restraint for forward and lateral accelerations. Use of an inertia reel in conjunction with the shoulder straps permits freedom of upper torso movement until the reel is locked by a forward acceleration.

5.2.1.2 Caboose Trainman Active Restraint Harness Systems

Accident investigations show that most caboose trainmen injuries occur from a seated position. A restraint harness system would minimize injuries from striking objects within the caboose due to accelerations from slack action, hard coupling, rear-end collisions or derailment. This necessity has been realized by caboose operators, and fabricators are providing restraint systems on seats for many railway customers.

A lap belt only restraint system can be considered for caboose trainmen provided adequate rotational clearance is maintained with equipment and furnishings. A lap belt alone should not be used for installation at the conductor's seat (Figure 5-9). Figure 5-10 shows the conductor's lap belt installation and the possible body injuries inflicted by forward and side accelerations. In the cupola caboose, the brakeman with lap belt may still encounter head injuries on the hand rail, window frame, or glazing, due to lateral acceleration (Figure 5-11).

Improved restraint of the conductor and brakeman can be provided by adding a shoulder harness to the lap belt. Addition of an inertia reel to the shoulder harness will permit full freedom of the upper torso if leaning away from the seat

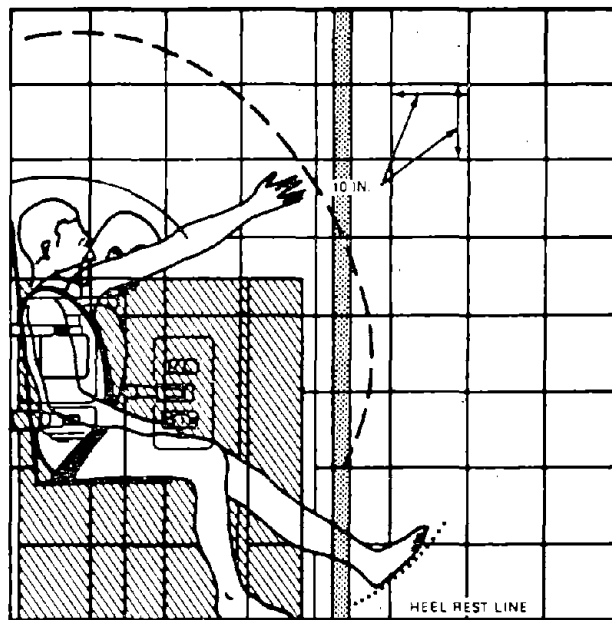
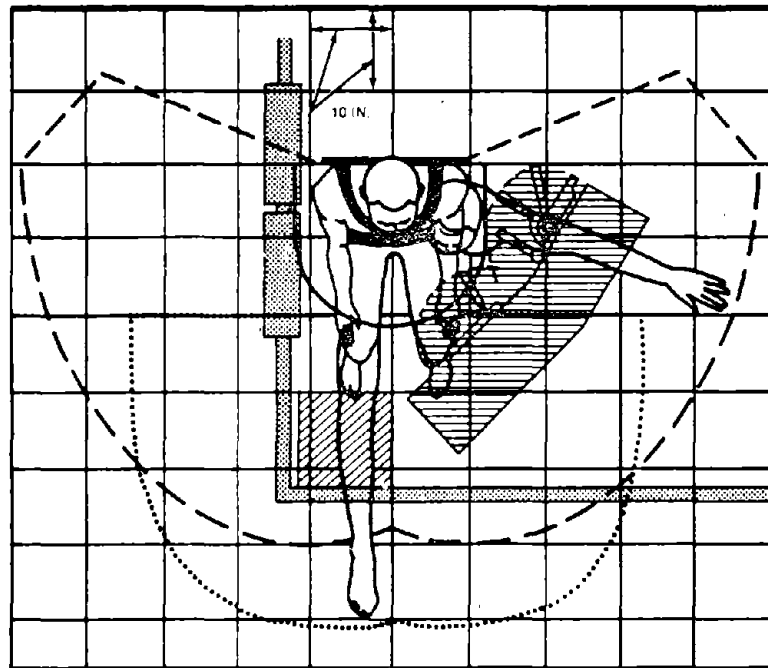

Figure 5-6. Engineman Rotational Envelope with Shoulder Strap

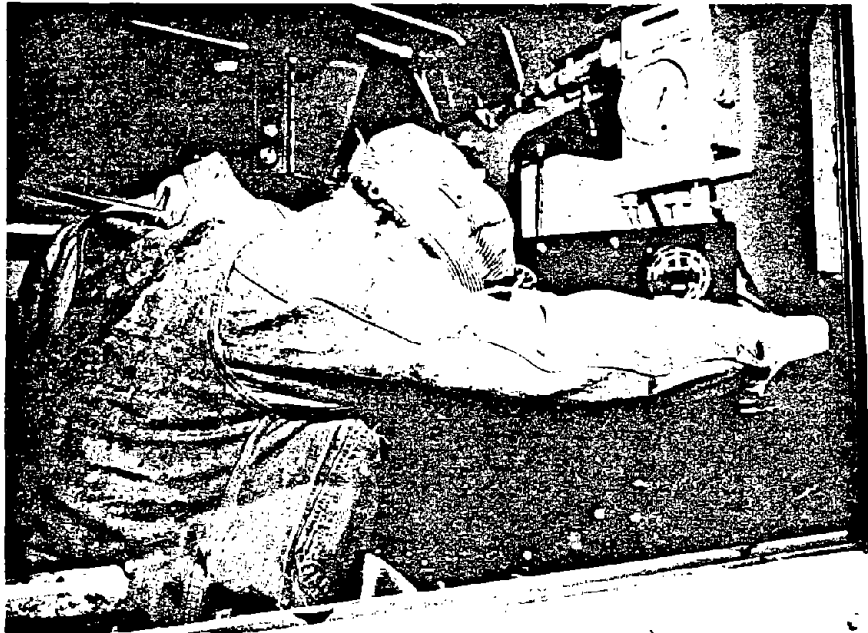
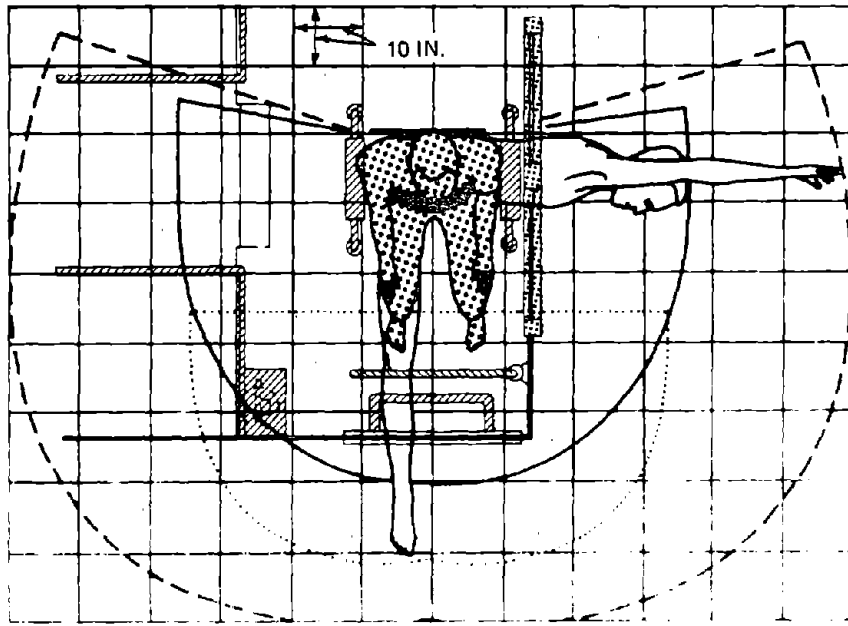

Figure 5-7. Shoulder Restraint on Engineman



Figure 5-8. Shoulder Restraint on Helper



BRAKEMAN - CABOOSE CUPOLA

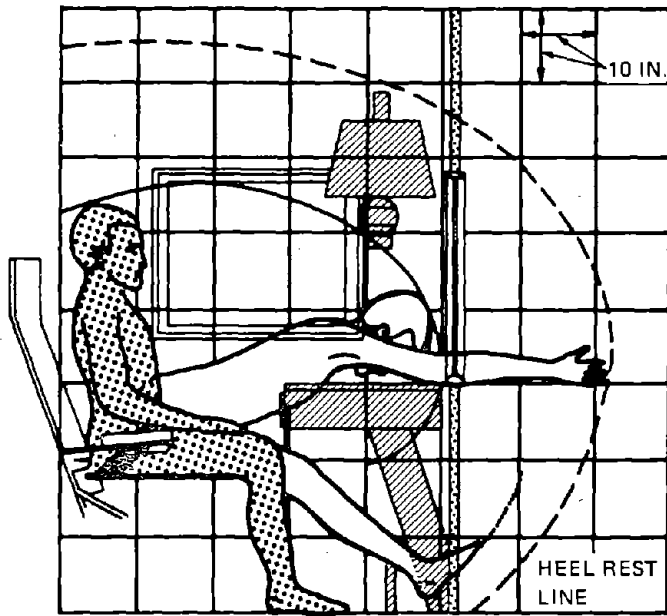

CONDUCTOR - CABOOSE

Figure 5-9. Rotational Envelope with Lap Belt - Caboose

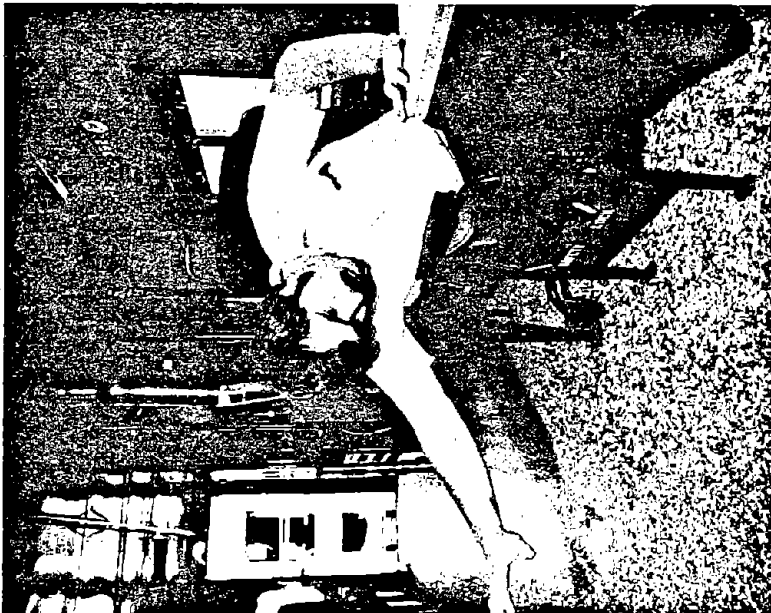

LATERAL ACCELERATION



FORWARD ACCELERATION

Figure 5-10. Conductor with Lap Belt Only

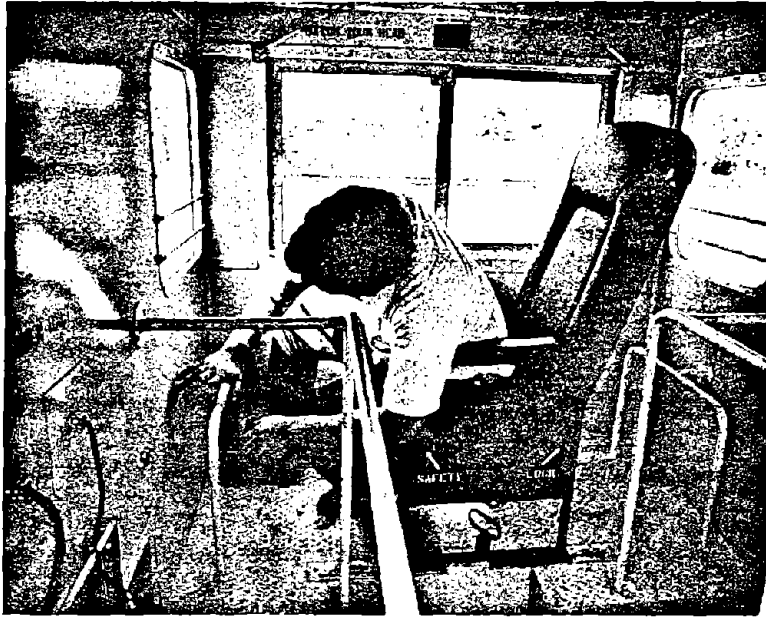

Figure 5-11. Brakeman with Lap Belt Only

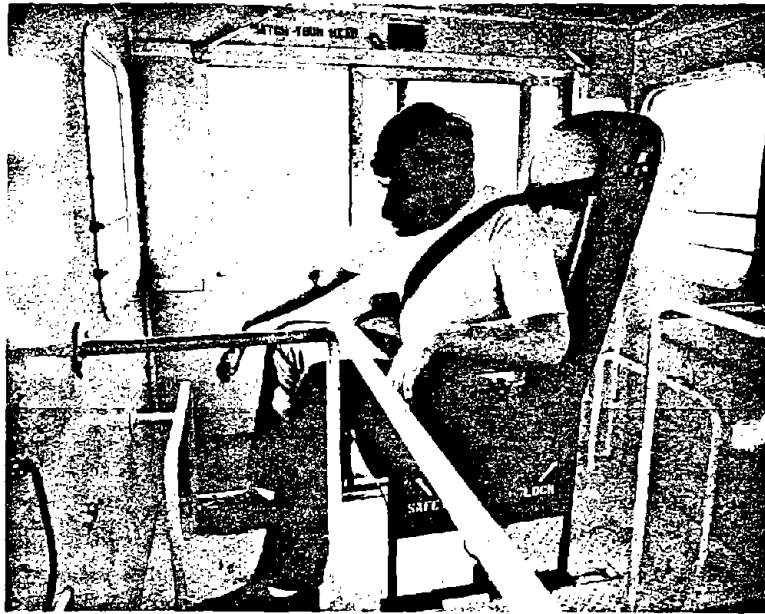

Figure 5-12. Brakeman with Lap Belt and Diagonal Shoulder Strap

back is necessary to perform normal duties. The use of the diagonal shoulder strap and lap belt combination reduces upper torso displacement under forward and side impact (Figure 5-12) where forward bodily contact with the bulkhead and the aisle guard rail is eliminated. Impact with the right side window/wall is still possible as the trainman can slip from under the diagonal shoulder restraint. Use of a double shoulder strap will provide restraint in both lateral directions as illustrated for the brakeman and conductor (Figures 5-13 and 5-14).

Providing a swivel seat with full restraint system for the brakeman/observer in the cupola would permit full coverage of all views from the caboose: front side and rear, while fully restrained. The conductor with a restraint harness likewise can perform his duties at the desk while fully restrained.

5.2.2 Passive Restraint and Containment Systems

Passive restraint or containment systems are those whose application do not require action on the part of the individual being protected. Three basic types of passive systems are as follows:

- Fixed passive restraint system which is a fixed part of the seating station
- Deployable passive restraint system which is deployed from a compartment at the instant of collision.
- Passive containment system which limits occupant travel distance from seat at collision and presents noninjurious impact surface.

5.2.2.1 Fixed Passive Restraint Systems

Fixed passive restraint systems should be considered primarily for locomotive and caboose occupants for forward accelerations. The system can consist of a padded structure permanently fixed in close proximity to the front of a seated occupant. This restraint or "buffer" should be configured to cover the abdomen and chest area of the occupant. The buffer should support the occupant at or above his center of gravity and prevent injury due to contact with hazardous items.

In a fixed seat, sufficient clearance should be provided for the occupant to slide into the seat from the side. Armrests, if installed may have to fold up to permit ingress or egress. A swivel seat or adjustable track-mounted seat can also be used to facilitate ingress or egress behind the buffer.

Buffers permanently fixed in front of a seated occupant's position should be placed as close to the occupant as practical.

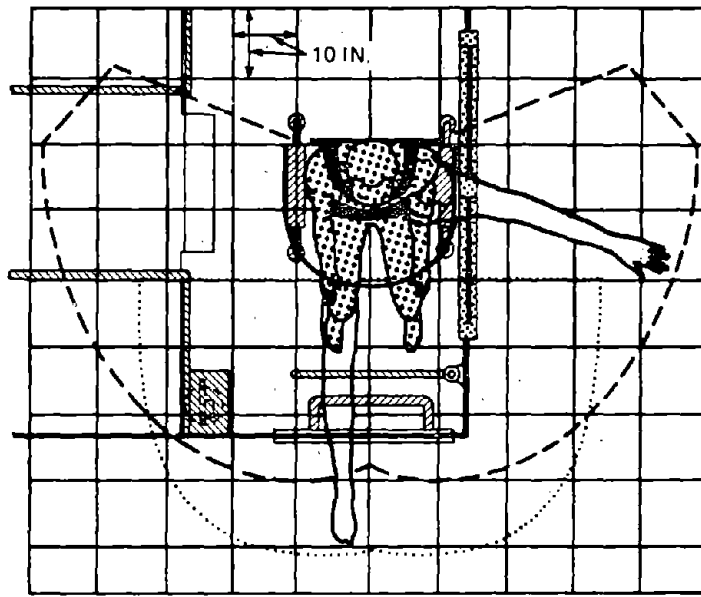

BRAKEMAN

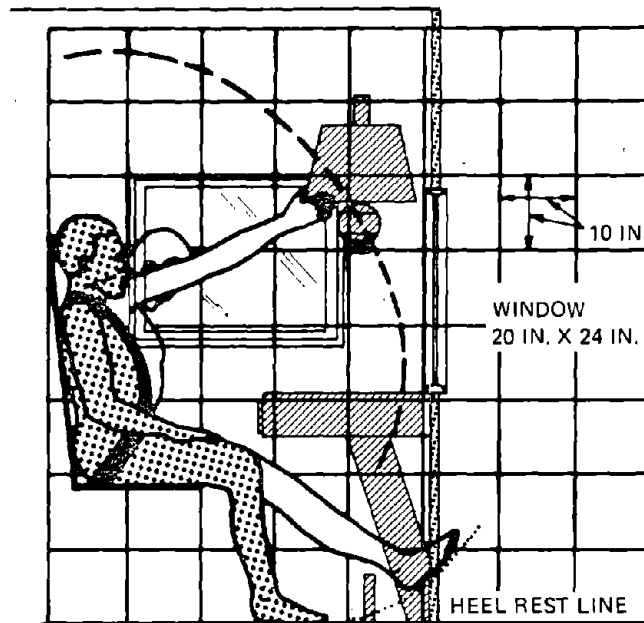

CONDUCTOR

Figure 5-13. Rotational Envelope with Shoulder Straps — Caboose



Figure 5-14. Conductor with Double Shoulder Strap System

Consideration should be given to the functions performed by the occupant and ingress and egress to the seat with the buffer in place. Clearance should be provided to permit a swiveling seat to rotate and to permit ingress to a fixed seat from the side for the heaviest occupant anticipated.

Buffers should be designed to be fixed in position. Rotating, swing-out, or adjustable buffers should not be considered if they can be left in an alternate position and not used. Buffers should be located to accommodate the full range of occupants expected to operate at the station. If an adjustable seat is used, it should also be taken into consideration in locating the buffer.

Materials selected for the cushion should not store energy and quickly release it to produce rebound. Deformable materials such as honeycomb may be used. It is preferable to use a material that will store the energy and slowly release it so that the device will restore itself to its original configuration and need not be replaced after an impact. Some foam materials with these properties are available.

Design of the energy-absorbing qualities of buffers, bulkheads, and padded surfaces depends on determining the maximum

distance between the surface in front of a seated occupant or the maximum distance a standee could travel before impacting a surface, after a collision. The further an occupant is from a given surface, the greater is his acceleration at impact, and, correspondingly, a more effective energy-attenuating cushion is required. Stiffness and thickness of the cushion design are discussed in paragraph 5.2.4.

5.2.2.1.1 Locomotive Fixed Passive Restraint System

Installation of buffers and padded surfaces is particularly applicable to locomotive trainmen stations. Existing locomotives can be retrofitted with the devices or new designs can incorporate the passive restraint devices in the new station configuration. An example of an existing locomotive engineer's station with a mockup of a buffer installation is shown in Figure 5-15 and Figure 5-16 shows an example of a helpers restraint buffer.

The criteria to be used for installation of the buffer restraint for locomotive trainmen is as follows:

- a. Non-interference with overall operating functions and ingress and egress

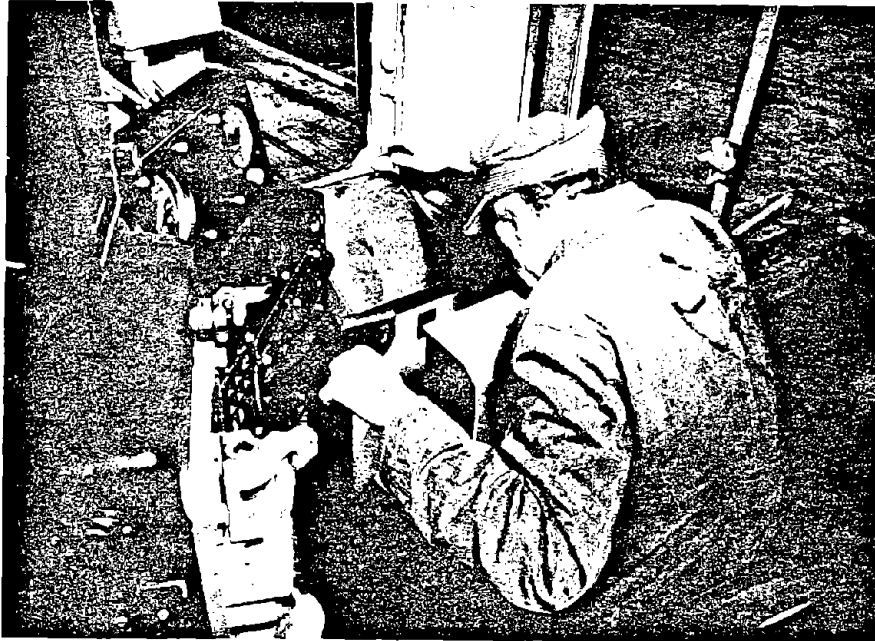

Figure 5-15. *Engineman's Restraint Buffer, Forward Impact*



Figure 5-16. Helper's Restraint Buffer, Forward Impact

- b. Maintenance of good visibility of track and controls for both forward and rearward operation
- c. Minimal rearrangement of equipment within the existing console structure for retrofit installations

An example of a typical design for engineman control console pad and chest buffer installation is shown in Figure 5-17. The buffer design provides restraint for forward acceleration and is extended to prevent impact with the control console handles.

The chest buffer is installed in front of the engineman in a fixed position supported from the side of the locomotive cab. An additional buffer is supported from the control console just below shoulder level and is positioned to "shade" the control handles without interfering with their operation. The size was minimized by regrouping of moving controls, and butted to the chest buffer to maximize the padded surface continuity. Rearrangement of switches and indicators was necessary for better visible reference using the eye level of the 50th percentile man (seated) as a basis.

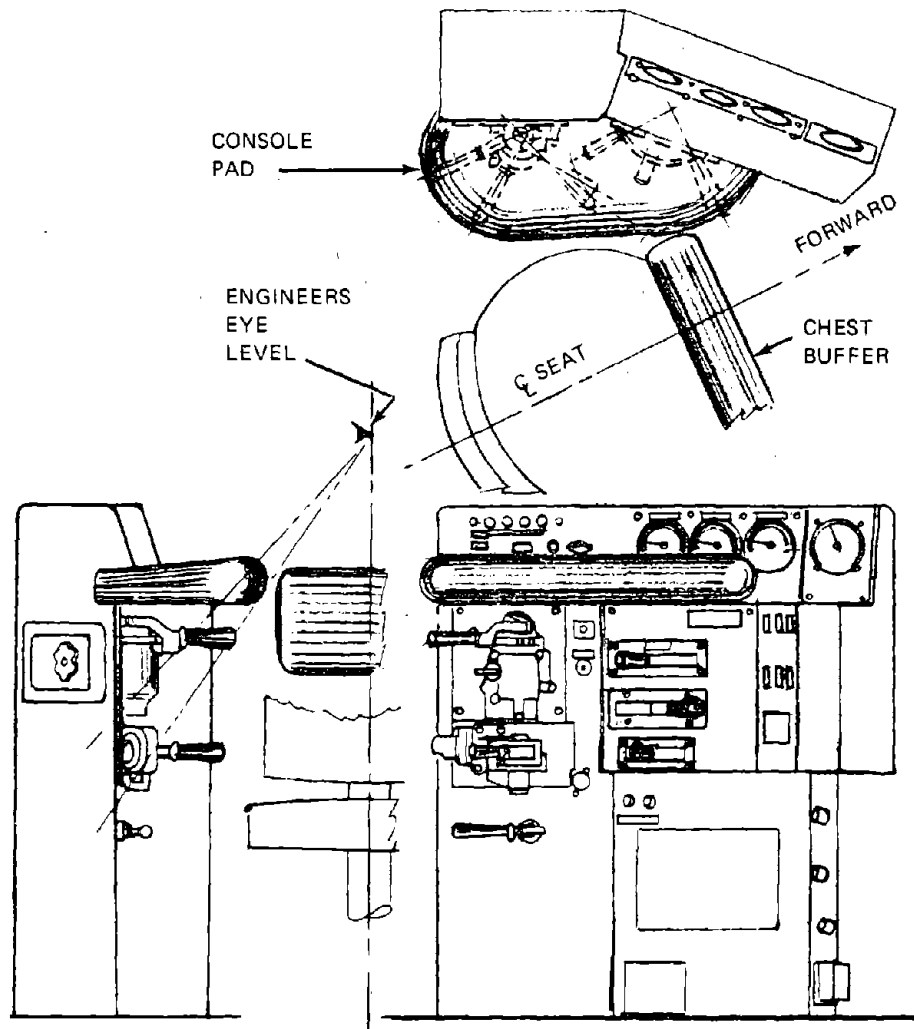

Figure 5-17. Existing Engineman's Station with Buffer and Padding

Necessary alterations in the controls, from their original position, are as follows:

1. Move train and locomotive brake valves down four inches
2. Relocate whistle valve handle below engine brake and rotate 90 degrees counterclockwise
3. Move indicators and power reduction lever from center to upper left portion of console.
4. Move indicators from right-hand edge toward engineman
5. Move pressure gage name plates from below gage face to above

Design of a new locomotive cab configuration¹⁸ permits more latitude in rearrangement of the engineman's controls and instruments. A suggested design concept with improved crash-worthiness features is shown in Figure 5-18; the design consists of the following:

- a. A contoured, semi-wraparound, cantilevered console incorporating a chest buffer and padded surfaces with unrestricted knee and leg area.
- b. Control valve handles located within easy reach for dual hand operation. Brake and power controls are grouped separately.
- c. Control, light, and other switches grouped in two flush panels distributed between right- and left-hand positions.
- d. A separate panel located over the front window containing air pressure gages, load current indicating meter, and indicating lights.
- e. An adjustable swivel seat with a high, anti-whiplash, headrest. The seat can be positioned to close proximity with the contoured console chest buffer.

Side-facing and limited rearward locomotive operation are still possible with the new control console. Duplicate controls can be provided for long duration rearward operation.

18. Robinson, J., et al, "LOCOMOTIVE CAB DESIGN DEVELOPMENT", Boeing Vertol Company, DOT-TSC-913, Department of Transportation, Transportation Systems Center, Cambridge, Mass., August 1975

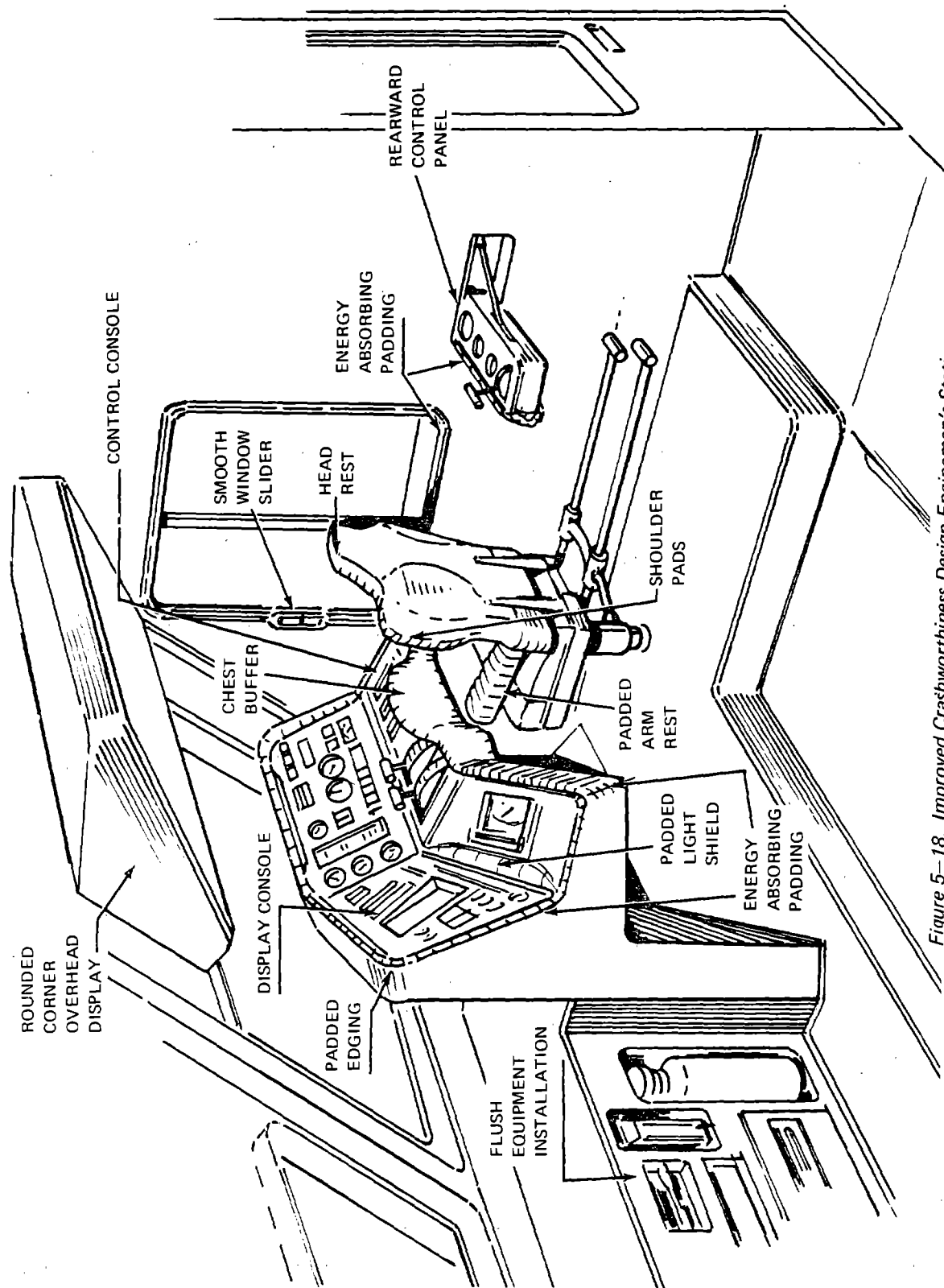

Figure 5-18. Improved Crashworthiness Design Engineman's Station

A variation of the above concept can be considered which provides a "wraparound" console improving passive restraint for forward and side directions and using an all-flush-control configuration for minimum lethality.

Benefits to be derived from these cab configurations are minimum encumbrance from passive restraint provisions and maximum protection during longitudinal and lateral accelerations. The design criteria for such a design are as follows:

- a. Decentralize controls and instruments to eliminate large console (a source of many injuries).
- b. Place hand controls on each side of a centrally located chest buffer.
- c. Design buffer pad sufficiently low to prevent pitching under the buffer (six inch maximum from top of seat) and sufficiently high to prevent upper torso rotation over the buffer (18 inch minimum from top of seat). Width to be maximum to spread load across torso.
- d. Design seat with headrest or high back to prevent rearward rotation of head (whiplash).
- e. Provide armrests and shoulder wings on seat for lateral restraint.
- f. Provide easily operable forward and aft adjustment of seat from seated or standing position to facilitate ingress and egress and permit adjustment to within close proximity of buffer.
- g. Design structure of control console and seat back to withstand a minimum of 8g acceleration of a 200 pound occupant without excessive deformation or failure.

5.2.2.1.2 Caboose Fixed Passive Restraint Systems

Installation of buffers as a passive restraint can be considered for caboose trainmen stations especially the conductor and brakeman/observer. The conductor's station is at a desk and he must be protected from being thrown into the edge of the desk. The brakeman/observer is stationed in a cupola or bay window and must be restrained from being thrown into the bulkhead or through the window ahead of him.

1. Conductor's station - design of a passive restraint buffer for the conductor requires the follow considerations:
 - a. Minimum encumbrance to the performance of the conductors duties of record keeping at his desk.

- b. Design of a buffer pad sufficiently low to prevent pitching under the buffer (six inch maximum above seat cushion) and sufficiently high to prevent upper torso rotation over the buffer (18 inch minimum from top of seat cushion).
- c. Buffer shall be built into the desk or installed in a manner so as not to be readily removable.
- d. Full length of desk face must be padded and height of face should be a minimum of five inches.
- e. Structure should be located outside of the rotational envelope of the occupant as much as possible (Figure 5-15).
- f. Design seat with headrest or high back to prevent rearward rotation of head (whiplash).
- g. Provide armrests and shoulder wings on seat for lateral restraint.
- h. Provide easily operable forward and aft adjustment of seat from seated or standing position to facilitate ingress and egress and permit adjustment to within close proximity of buffer.
- i. Design structure of desk and seat to withstand a minimum of 15g longitudinal acceleration and 5g lateral for a 200 pound occupant without excessive deformation or failure.
- j. Padding should be designed to minimize injury in accordance with procedure described in paragraph 5.2.4.

A mockup of a suggested conductor chest buffer is shown in Figure 5-19 and motion envelope in Figure 5-20.

- 2. Brakeman's station - design of a passive restraint buffer and seat for the brakeman station requires the following considerations:
 - a. Buffer should extend to cover the full width of the seat.
 - b. The bottom of the buffer should be a maximum of six inches above the seat cushion and the top of the buffer should be a minimum of 18 inches above the seat cushion.

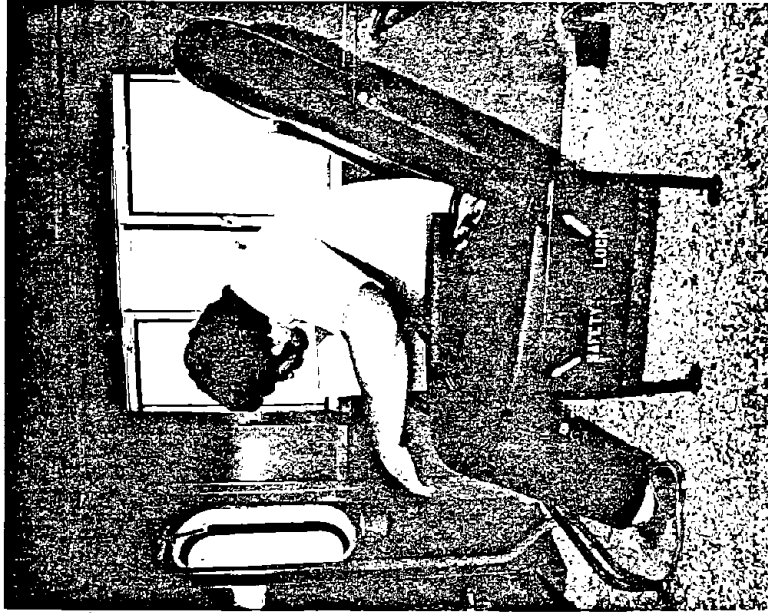

BRAKEMAN



CONDUCTOR

Figure 5-19. Chest Buffer Installations in Caboose

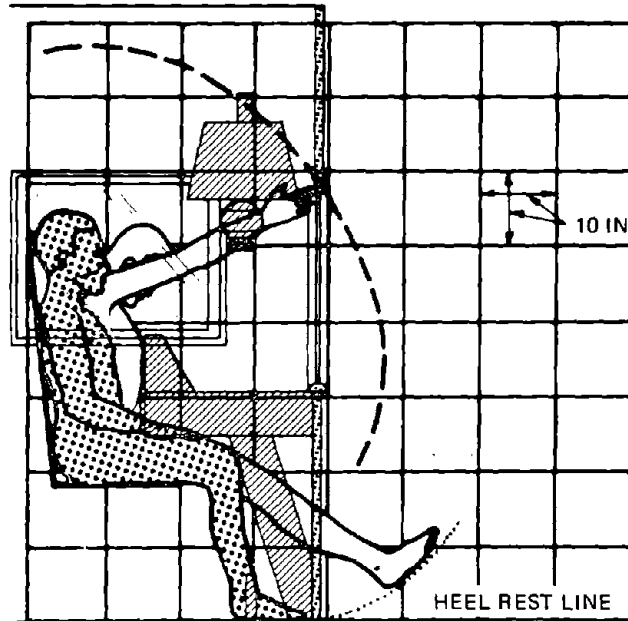

Figure 5-20. Conductor Chest Buffer Restraint Rotational Envelope

- c. The end of the buffer should be permanently fixed to the side of the caboose and should not fold or rotate to permit ingress or egress.
- d. A second buffer should be provided behind the seat for when facing rearward.
- e. Design seat with head rest or high back to prevent rearward rotation of head (whiplash).
- f. Provide arm rests and shoulder wings on seat for lateral restraint.
- g. Provide easily operable forward and aft adjustment of seat from seated or standing position to facilitate ingress and egress and permit adjustment to within close proximity of buffer.
- h. Design structure of buffer and seat to withstand a minimum of 15g longitude acceleration, and 5g lateral for a 200 pound occupant without excessive deformation.
- i. Padding should be designed to minimize injury in accordance with procedure described in paragraph 5.2.4.

A mockup of a suggested brakeman's buffer is shown in Figure 5-19. Lateral restraint provisions are shown in Figure 5-21.

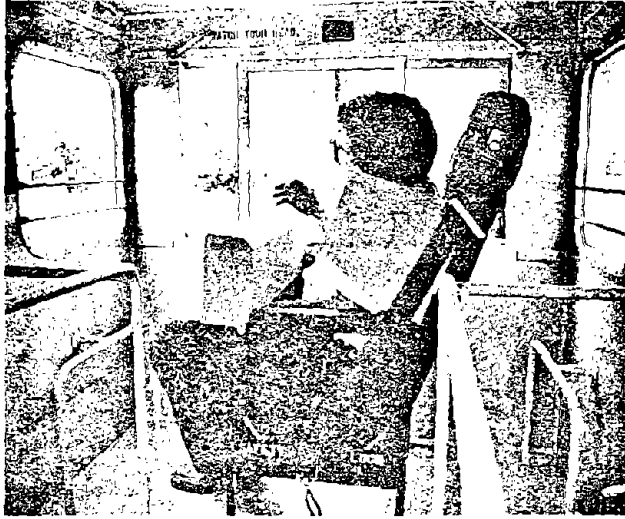

Figure 5-21. Lateral Shoulder Buffer Restraint



Figure 5-22. Automatic Inflating Air Bag Restraint

5.2.2.2 Deployable Passive Restraint Systems

A deployable restraint system can be considered for rail vehicle occupant restraint for installation if suitable structure or furnishings are in close proximity to the front of a seated occupant. The air bag system is an example of a deployable passive restraint. This system consists of an inflatable bag. An acceleration-sensitive switch is needed to cause gas from a storage cylinder to be released into the bag when a predetermined acceleration is exceeded. The space between the structure and the occupant becomes filled with the bag and prevents the occupant from striking the structure or from being thrown from the seat.

Installation of an air bag system requires a suitable structure 18 to 24 inches in front of the occupant for a mounting surface. A control panel, desk or bulkhead would be suitable for installing the system. A conductor's desk is an example of a suitable mounting surface.

5.2.2.2.1 Conductors Deployable Restraint System

The requirements for the air bag system installation which are in addition to the applicable requirements specified for the conductor's buffer installation (5.2.2.1.2) are as follows:

- a. Provide a compartment in the desk to stow the air bag.
- b. Provide sufficient desk front surface to react the impact loads on the deployed air bag.
- c. Provide a covering over the air bag to prevent abrasion from normal desk use.
- d. Provide a compressed gas source such as air or carbon dioxide to inflate the air bag.
- e. Provide an acceleration sensitive switch which will cause the gas to be released into the air bag when longitudinal or lateral acceleration exceeds 2g.

A mockup of a conductors deployed air bag is shown in Figure 5-22.

5.2.3 Passive Containment and Protection Systems

A containment system is used to limit the distance occupants are thrown from their seat or from a standing position. It provides a surface which will attenuate the impact forces and limit the loads on the occupant to tolerable levels.

Passive containment systems are particularly applicable for rail vehicle passengers and to a limited degree for locomotive and caboose trainmen.

Rail vehicle passengers for the most part are seated while the vehicle is in motion. Therefore the principal consideration for crashworthiness design should be concentrated on the seating area. Maximum advantage should be taken of the furnishings around the passenger for restraint or containment during accelerations resulting from collision and derailment. Application of an active restraint system for passengers should be avoided. Passive means of providing containment and protection should be considered for each passenger station.

Also of importance for crashworthiness design considerations are the areas where passengers or railway personnel are standing, walking or performing their duties. Specific areas for containment design considerations are as follows:

- Backs of passenger and tandem trainmen seats
- Partitions and bulkheads in front of seats
- Dining car areas
- Snack bar areas
- Lavatories
- Bunks and berths

5.2.3.1 Backs of Passenger and Tandem Trainmen Seats

Since the seat is the closest item to the railcar occupant, it is of prime importance in crashworthiness design. Passenger seats and trainman seats without other restraint provisions serve as the principal containment for occupants. Provisions for impact due to acceleration must not only be added to the occupants' seats but also to the backs of the seats they face. The following crashworthy features should be considered for seat design:

- High seat back
- Impact design for rear of seat back
- Anti-leg-entrapment skirt
- Shoulder buffers
- Padded arm rests
- Anti swivel lock
- Impact loads

- a. High Seat Backs - Seat backs or head rest extensions should extend a minimum of 34 inches above the seat reference point (the intersection of the top of the seat cushion and the seat back). The area behind the head should not be more than two inches behind the plane of the seat back. Extensions in front of the seat back plane are acceptable but should not be greater than two inches, or be an abrupt departure from the back plane surface. Extensive contouring of seat backs should be avoided so as to provide a more even distribution of rearward loading for small as well as large occupants. Spreader bars or ribs in the back should not be used so as not to produce concentrated loading on the occupant under rearward acceleration or for forward acceleration into seat backs. Continuous load supporting membranes should be used in the backs rather than intermittent members.

- b. Seat Back Design - The rear of seat backs should be sufficiently padded to minimize injury to passengers who are thrown into the backs of seats. Seat backs should be void of rigid handholds, ticket holders, head rest towel clips, etc. The top of the seat back which could be struck by the head, face, or chest should be covered with a soft cushion which does not exceed a stiffness which would cause nose injury. The cushion should be sufficiently soft to permit penetration of the nose and allow the force to be distributed over the face and forehead. A force of 10 pounds per square inch should not be exceeded. The distance the occupant is seated from the cushion determines the thickness of the cushion and can be calculated using the procedure described in paragraph 5.2.4.

In the area of the knees, seat backs should be kept clear of rigid, nonyielding members. This area should be designed to absorb the energy of a 170-pound occupant impacting with the knees without exceeding the human tolerance for the knee-leg-hip complex discussed under Human Tolerance (Section 4.0). The energy-attenuating properties for various impact distances are discussed in paragraph 5.2.4.

- c. Seat Back Skirt - The area from the bottom of the seat cushion to the floor, in back of the seats, is usually clear allowing the legs of occupants in the rear of a seat to slide under the seat. The injurious potential of this arrangement has been discussed previously. A skirt should be provided in this area to allow no more than the foot to extend under the skirt. There should be an opening approximately six inches from the bottom of the skirt to the floor. The skirt should be angled

forward sufficiently to permit maximum leg room yet not enough to allow a fulcrum to form. The bottom of the skirt should be rounded with approximately a 2-inch radius and padded with a minimum of 1/4 inch of foam.

- d. **Shoulder Buffers** - To improve containment for lateral accelerations, it is desirable to add shoulder buffers to the sides of passenger seats. The buffers should be approximately 7 inches wide by 10 inches long; the top of the buffer should be 24 inches above the seat reference point. A generous radius should be provided on all corners. Sufficient padding should be applied to all exposed surfaces.
- e. **Armrests** - Armrests are desirable, not only for comfort but to improve containment. The area of the armrest from the top of the seat cushion should be enclosed and padded; this will distribute the body load over a large area during lateral acceleration.
- f. **Anti-Swivel Locks** - Passenger seats in general use are reversible in direction by pulling the seat inward and then rotating the seat 180 degrees. In a collision (especially derailment), where lateral accelerations are present, the seats become disengaged and are free to swivel. Any crashworthy features added to a seat would be negated with this feature present. If a seat must be reversible, a positive locking device must be provided to prevent inadvertent seat rotation. Reversal of seats to a face-to-face arrangement must be avoided. Unlocking for reversal must be by a special tool or key for use by train personnel only.
- g. **Design Loads** - Passenger seats should be structurally designed to withstand the load of a 200-pound occupant thrust rearward into the seat back at 8 g, or 1,600 pounds, without failure or excessive deformation. The seat should also withstand loads of 800 pounds applied in a forward direction to the top area of the seat back and loads of 800 pounds applied simultaneously to a point to the seat back 20 inches above the floor. This loading simulates an occupant behind the seat being thrust into the seat back and contacting it with the knees and upper torso. Armrests and shoulder buffers should be designed to withstand distributed loads of 425 pounds applied to each simultaneously. Double-occupancy seats should be designed to withstand the above loads applied to each segment of the seat simultaneously. Carrythrough structure and floor attachments should withstand the total loading without failure, excessive deformation, or unlatching of the seat rotation locking device.

In general, locomotive and caboose seat design requirements are the same as for passenger seats. Seats used in tandem will require impact protection design of the rear surface of the seat back, including the anti-leg-entrapment skirt. Seats which employ lap belts and shoulder straps must be designed to withstand the strap loads. The design load for the lap belt attachment to a locomotive seat pan is 2000 pounds divided between each side of the seat. Locomotive seat backs with shoulder strap attachments must be designed to withstand a load of 1000 pounds applied to the point of single or double shoulder strap attachment.

Design of longitudinally adjustable and swiveling seats must preclude disengagement from tracks or base when experiencing accelerations about any of the three axes. The occupant should be able to make longitudinal adjustments without getting up from his seat. A positive lock should maintain the seat in the adjusted position. Individual seats with a swivel feature do not need swivel locks although detents are desirable.

Locomotive trainmen's seats which do not have restraint system attachments should be designed to the same loading requirements as passenger seats. This applies to seat back loading, carry-through structure and floor attachments, and lateral loading on armrests and shoulder buffers.

Caboose trainmen's seats are subjected to much higher collision loads than locomotive and passenger seats and must be designed accordingly. Seats with restraint system attachments should be designed for a 3000-pound lap belt load divided between the seat pan attachments on each side of the seat. Seat backs with shoulder strap attachments must be designed to withstand a load of 1500 pounds applied to the point of attachment of single or double shoulder straps. Seats with or without shoulder straps should be designed to withstand the load of a 200-pound occupant thrust rearward in the seat back at 15g or 3000 pounds. Caboose seats placed in tandem should have backs designed for rear occupant impact protection meeting the same requirements as passenger seat backs. Lateral loading requirements for armrests and shoulder buffers is the same as for the above seats. Carry-through structure and floor attachments should withstand the maximum of the above loads in each direction without failure or excessive deformation.

5.2.3.2 Partitions and Bulkheads

Partitions or bulkheads behind which passengers or trainmen are seated or which are subject to impact from standing occupants should be designed to absorb the impact energy. Use of glass, mirrors, pamphlet or magazine racks or other rail vehicle equipment on the partition or bulkhead should be

avoided. Seats behind bulkheads used for containment should be located as close to the bulkhead as practical to minimize the distance the occupant can be thrown, thereby reducing the acceleration. Foot clearance wells below the partition are recommended to permit adequate foot clearance while moving the partition closer to the occupant.

The partition should be constructed in a manner such that rigid formers or stiffeners are not located in areas likely to be struck by the seated occupant's knees or head when thrust forward into the partition. The partition and particularly the likely areas to be impacted should be designed to yield under impact. A nonyielding bulkhead should be adequately padded. A maximum stiffness for passenger car partitions of 3000 pounds per inch should be used and should deform a minimum of one inch. For further detail design data refer to the procedure described in paragraph 5.2.4.

5.2.3.3 Dining Car Occupant Containment

Designs for containment of occupants seated in the dining area should utilize the furnishings to a maximum extent. Accelerations anticipated in a dining car are less than those that would be experienced in a caboose or locomotive, therefore the use of buffers or other restraining devices is not necessary. Sufficient padding should be added to the faces of the tables which should be a minimum of five inches high. Depth and spring rate of the padding should be determined by the procedure described in paragraph 5.2.4. The material used in the padding should be nonelastic or should have slow rebound properties.

The table to serve as a containment for the occupant must be rigidly fixed to the side of the railcar and floor. It should be designed to withstand a force of 2400 pounds applied at the center of the table in a forward or rearward direction without tearing loose or without excessive deflection.

Chairs at the dining car tables should serve to contain occupants for rearward acceleration. The chairs should be fixed to the floor or should be restricted from moving more than six inches rearward from a neutral seating position by the use of a barrier. Seat back height should be a minimum of 34 inches above the seat reference point to contain the head and prevent whiplash. The seat backs while against the barrier or while fixed to the floor must withstand a load of a 200 pound occupant at 8g or 1600 pounds distributed over the surface without excessive deformation or failure. If a barrier is used it should withstand the loading of two seats simultaneously. A continuous padded surface free of openings should be used for the seat backs to distribute the load evenly over the occupants backs.

5.2.3.4 Snack Bar Area Containment

Areas of passenger cars normally occupied by standing passengers such as snack bars, club car bars, etc. should be provided with containment provisions to limit the distance occupants can be thrown during a collision. Panels, partitions or compartments can be used for containment. The partitions should be designed for controlled deformation or should be sufficiently padded with an energy-absorbing material to reduce collision impact forces to the no injury human tolerance level. Impact attenuation requirements will be dependent upon the distance an occupant can be thrown to the partition. The procedure described in paragraph 5.2.4 should be used in designing the force/deflection characteristics.

Counters, bars, shelves, etc. should be designed to present as much flat surface area as possible to distribute impact forces over a maximum area of the body. Orientation of such counters perpendicular to the length of the car should be avoided. If not practical then the forward or rearward surface of such counter should be designed to absorb collision impact energy in a manner similar to the partition designs.

5.2.3.5 Lavatory Area Containment

Provisions should be made to contain seated or standing occupants in a rail vehicle whether it be in a passenger car, caboose or locomotive. Bulkheads, partitions, or doors should be provided as a barrier to limit the occupants travel as a result of collision. Toilets oriented in a forward or rearward direction should have a barrier placed a maximum of 14 inches in front of the seat and immediately behind the seat. Toilets oriented in a lateral direction should have barriers placed 14 inches on each side of the centerline of the seat. The barriers should be designed to deform at a force level below the human injury level or should be padded with an energy-absorbing material to reduce collision impact forces. Impact accelerations vary for various type rail vehicles and the procedure described in paragraph 5.2.4 should be referred to in the design of the barriers.

5.2.3.6 Bunk and Berth Area Containment

Provisions should be made to contain an occupant lying on a bunk or berth during a collision acceleration. It is preferable that the bunk be oriented in a longitudinal direction. A barrier should be placed at each end of the bunk to prevent longitudinal ejection from the bunk. The barrier can be of a fabric or webbing material. If a solid partition is used it should be designed to deform at a noninjury force level under collision impact from the occupants head or feet. The amount of deformation required varies depending on the type of rail

vehicle. The amount of force/deflection or the amount of padding necessary can be determined by the procedure described in paragraph 5.2.4.

Lateral containment should be provided for bunk occupants by padding the closed side of the bunk and by providing webbing straps placed one-third the length of the bunk, from each end, on the open side. The straps should be a minimum of four inches wide and should extend from the bunk surface to the ceiling or to the upper bunk. Each strap should withstand a load of 1000 pounds applied at the center of the strap.

5.2.3.7 Restraint and Containment Summary

Restraint selection is dependent upon the application. Selection criteria include the degree of hazard exposure, the presence of work functions, the mobility desired, and expected acceptance of the restraints.

The use of active restraints such as the lap belt have been successful where confinement and delethalization of surrounding space was more acceptable than being thrown from the seat. Where space limitations prevail and delethalization is inadequate, the more complex lap belt and shoulder harnesses are used.

Passive restraints offer alternatives to active restraints whose use is often ignored, and where confinement is not accepted or would be an impediment to work performance. Padded surfaces, buffers, and automatically applied air bags are typical of such applications.

A general comparison of the advantages and disadvantages of various restraint systems for intercity transit is made in Figure 5-23.

5.2.4 Passive Restraint and Containment Energy Absorption Design

Design for occupant protection from injury due to acceleration into a surface during a collision is dependent upon the following factors:

- The velocity of the rail vehicle at the time of collision
- The type of rail vehicle in which the occupant is riding
- The distance the occupant travels to the surface impacted







RESTRAINT	ADVANTAGES	DISADVANTAGES
<p>NONE</p> 	<ul style="list-style-type: none"> - COMPLETE FREEDOM TO MOVE WITHIN RAILCAR AS NECESSARY - HIGH ACCEPTANCE 	<ul style="list-style-type: none"> - CAN BE THROWN INTO BULKHEADS, SEATS, TRAIN EQUIPMENT, OR THROUGH WINDOWS CAUSING SERIOUS INJURY
<p>PADDED SURFACES</p> 	<ul style="list-style-type: none"> - COMPLETE FREEDOM WITHIN RAILCAR - REDUCED IMPACT FORCES AND INJURY - HIGH ACCEPTANCE 	<ul style="list-style-type: none"> - LONGITUDINAL CONFINEMENT ONLY - REQUIRES OTHER RESTRAINT PROVISIONS FOR LATERAL AND VERTICAL ACCELERATIONS
<p>LAP BELT</p> 	<ul style="list-style-type: none"> - ELIMINATES BEING THROWN ACROSS CAR OR INTO LETHAL OBJECTS - SIMPLE ATTACHMENT AND RELEASE 	<ul style="list-style-type: none"> - PERMITS JACKKNIFING - LACKS UPPER TORSO AND LATERAL RESTRAINT - HEAD AND LIMB INJURIES POSSIBLE - CONFINEMENT - LOW ACCEPTANCE
<p>LAP BELT AND DOUBLE SHOULDER HARNESS</p> 	<ul style="list-style-type: none"> - ELIMINATES SERIOUS INJURY - PROVIDES RESTRAINT IN ALL DIRECTIONS 	<ul style="list-style-type: none"> - INSTALLATION PROCEDURE DISCOURAGES USE - CONFINEMENT - LOW ACCEPTANCE
<p>CHEST BUFFER</p> 	<ul style="list-style-type: none"> - ELIMINATES BEING THROWN INTO LETHAL OBJECTS - NO INSTALLATION ACTIONS - MINIMIZES IMPACT 	<ul style="list-style-type: none"> - FORWARD RESTRAINT ONLY - PARTIALLY CONFINING - LOW ACCEPTANCE
<p>AUTOMATIC AIR BAG</p> 	<ul style="list-style-type: none"> - COMPLETE FREEDOM OF RAILCAR - CONFINES OCCUPANT TO SEAT AT SMALL TIME INTERVAL AFTER CRASH 	<ul style="list-style-type: none"> - DIRECTIONAL RESTRAINT PRINCIPALLY FORWARD - COMPLEX AND MORE COSTLY SYSTEM - REQUIRES SUPPORT STRUCTURE CLOSE TO FRONT OF OCCUPANT - LOW ACCEPTANCE

Figure 5-23. Restraint and Containment Summary

- The part or parts of the body which contact the surface
- The area of the body that contacts the surface
- The area of the surface contacted
- The energy absorption or deformation characteristics of the surface

These factors must be considered in the design of a bulk-head, seat back, buffer or other padded surface to reduce the impact forces on the occupant to within human tolerance limits.

5.2.4.1 Design of Energy Absorbing Surfaces

Energy-absorbing characteristics of padded surfaces impacted depend upon the padding stiffness and thickness. Using simple calculations and graphs, it is possible to determine the padding stiffness and thickness necessary to insure that specified body pressure or human tolerances are not exceeded during impact. Impact tolerances to various parts of the body are discussed in Human Tolerance, Section 4, and a summary of the body pressure limits are presented in Table 4-2.

In order to determine the required padding properties, the impacting body's kinetic energy and the body contact area must be known. The velocity of the body at impact and the masses of the body segments for a 156-pound occupant are given in Figure 5-24; from these the kinetic energy can be calculated. The body contact area is estimated by the designer. From the kinetic energy and the padding contact area, the kinetic energy density, μ , defined as the kinetic energy, per body padding contact area (inch-pounds per square inch), is determined. Assuming a padding thickness, and with the previously calculated kinetic energy density, μ , a minimum padding stiffness value can be obtained (Figure 5-25). With the known body pressure tolerance (Table 4-2) and the kinetic energy density, μ (Figure 5-26), the maximum allowable cushion stiffness is obtained, the designer can then select a suitable padding material within the range of these stiffness values.

Example

Determine the required padding for a chest buffer 10 inches from the locomotive engineman's chest. An arbitrary padding thickness of 3 inches is used.

- Step 1 - Calculate Kinetic Energy

$$K.E. = 1/2M V^2$$

BODY SEGMENT	MASS DISTRIBUTION FOR 156-LB OCCUPANT	EQUIVALENT WEIGHT DISTRIBUTION FOR 156-LB OCCUPANT
HEAD	0.05176 LB SEC ² /IN.	20.0 LB
CHEST	0.12008 LB SEC ² /IN.	46.4 LB
PELVIS	0.13200 LB SEC ² /IN.	51.1 LB
UPPER LEG	0.06640 LB SEC ² /IN.	25.7 LB
LOWER LEG	0.03312 LB SEC ² /IN.	12.8 LB

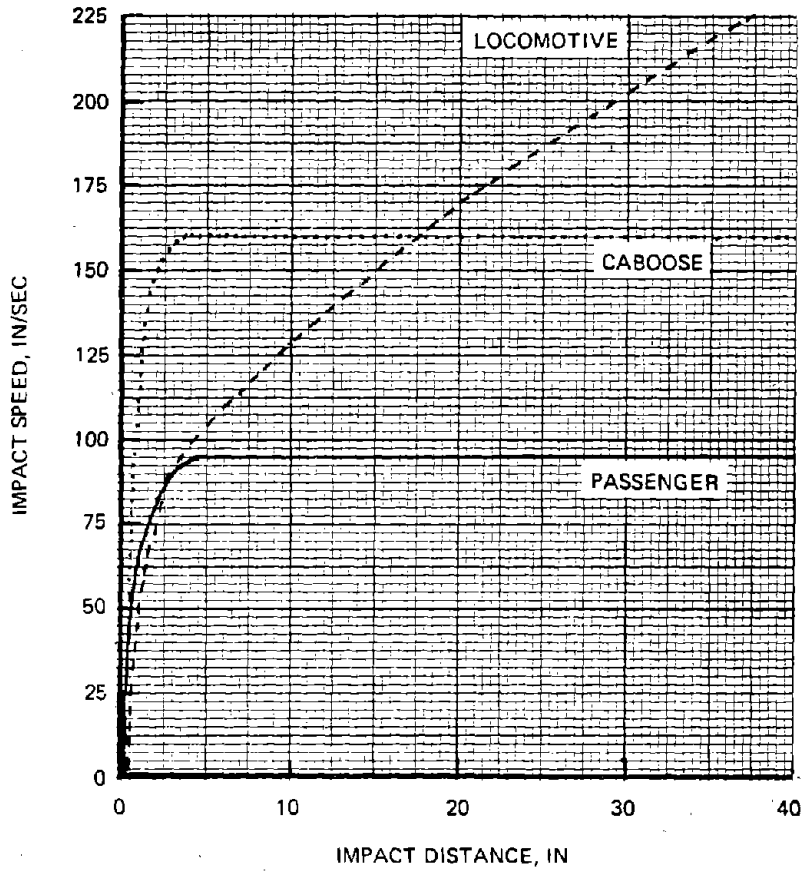

Figure 5-24. Body Impact Velocity vs Distance Traveled

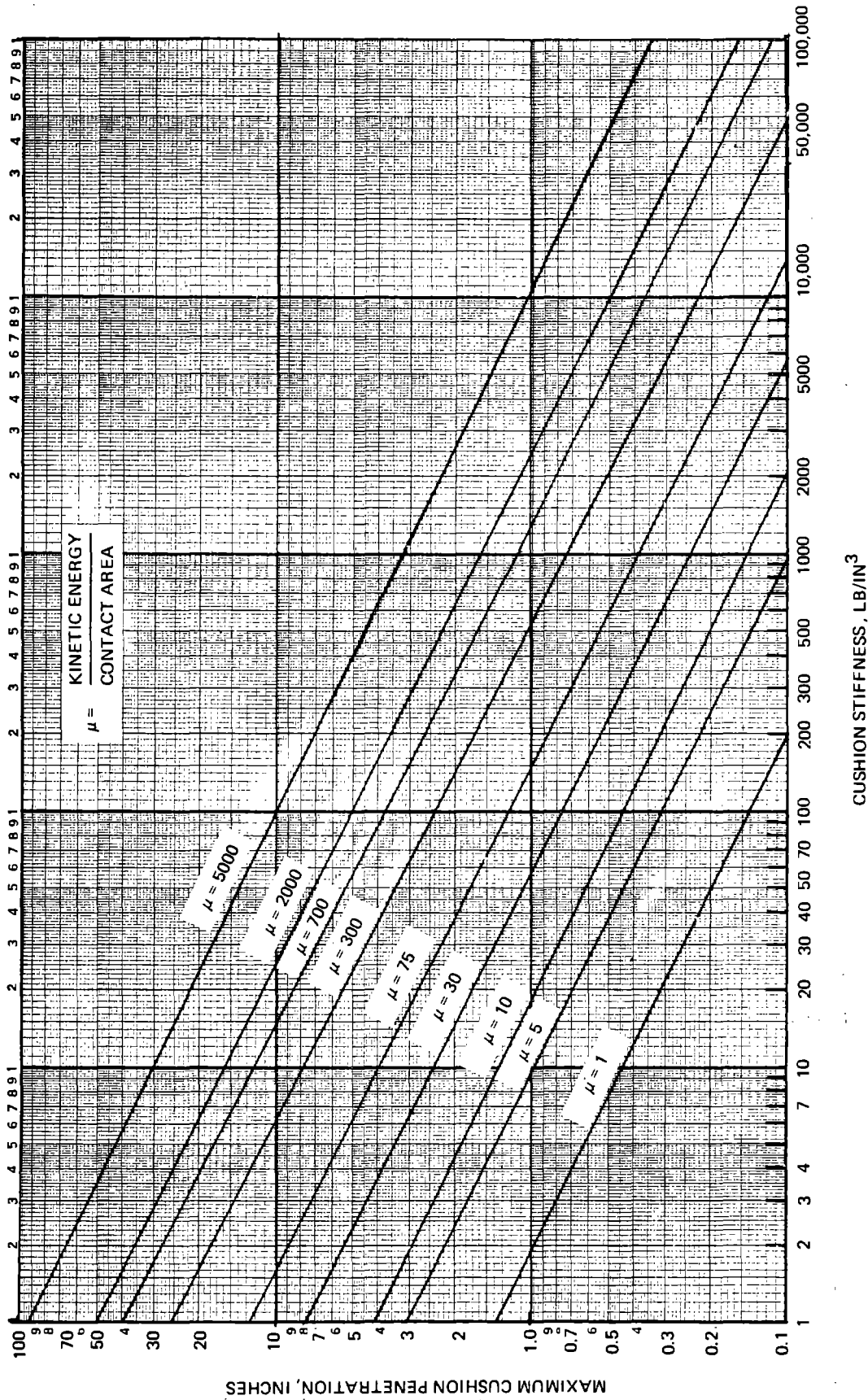

Figure 5-25. Cushion Penetration vs Cushion Stiffness

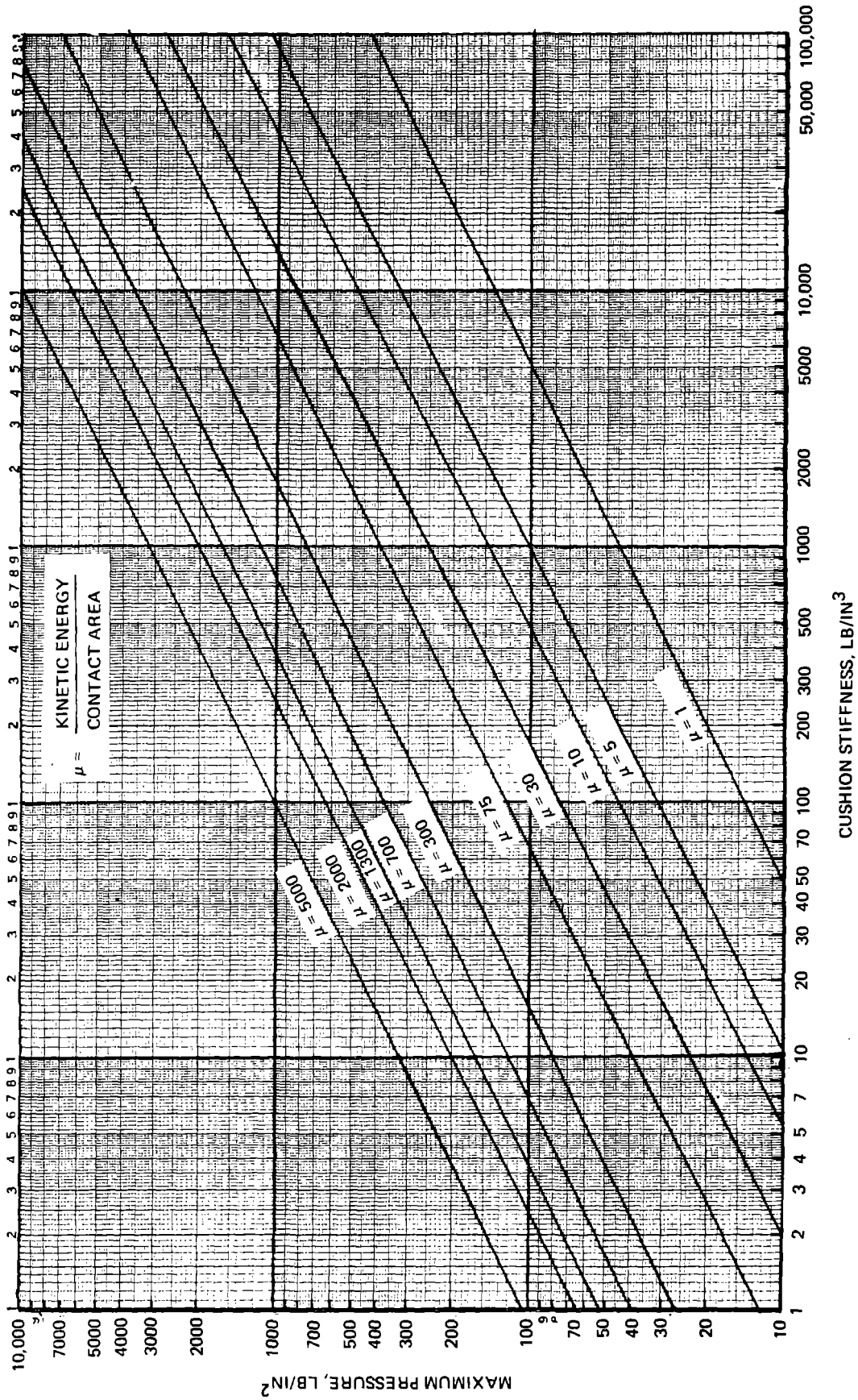

Figure 5-26. Impact Pressure vs Cushion Stiffness

- a. With the known impact distance of 10 inches, the impact speed is found to be 128 in./sec on the locomotive curve (Figure 5-24).
- b. From Figure 5-24, the chest mass is found to be 0.12008
- c. Therefore the kinetic energy = $1/2 (0.12008) (128)^2 = 983.7$ in.-lb

- Step 2 - Determine the Contact Area

- a. The chest/cushion contact area is assumed to be 36 square inches. The designer will base his assumption on design geometry, occupant position, area of the body likely to impact the surface, etc.

- Step 3 - Calculate the Kinetic Energy Density, μ

$$\mu = \frac{983.7 \text{ in.-lb}}{36 \text{ in.}^2} = 27.3 \text{ in.-lb/in.}^2$$

- Step 4 - Determine Minimum Padding Stiffness

- a. Using the assumed padding thickness of 3 inches and kinetic energy density or, μ , of 27.3, the minimum padding stiffness value is determined from Figure 5-25.

$$K_{\text{minimum}} = 6.6 \text{ lb/in.}^3$$

This minimum stiffness value is controlled by padding thickness. For the padding to be effective, the occupant must be decelerated within the working range of the padding.

- Step 5 - Determine the Maximum Padding Stiffness

- a. From Table 4-2 the chest pressure tolerance is found to be 40 pounds per square inch.
- b. Knowing that μ , the kinetic energy density, is 27.3 in.-lb/in.², the maximum padding is determined from Figure 5-26.

$$K_{\text{maximum}} = 29 \text{ lb/in.}^3$$

The maximum value of the stiffness is controlled by the body pressure tolerance. Stiffer padding values would exceed human tolerances.

- Note: If the value calculated in Step 4 exceeds the value calculated in Step 5, this indicates a greater padding thickness is necessary. A greater padding thickness is estimated and Steps 4 and 5 must be repeated.

5.2.4.2 Typical Energy Absorbing Properties of Rail Vehicle Surfaces

Typical occupant impact scenarios for locomotives, cabooses and passenger railcars in collisions are presented in Figures 5-27, 5-28, and 5-29 respectively. Impact forces on the occupants are determined using the procedures of 5.2.4.1 for each scenario presented. Energy absorbing properties of equipment, furnishings and structures found in existing rail vehicles are used in determining the impact forces and resulting injuries. Where injuries are determined to be probable corrective actions are recommended and listed in a matrix (Tables 5-1, 5-2, and 5-3).

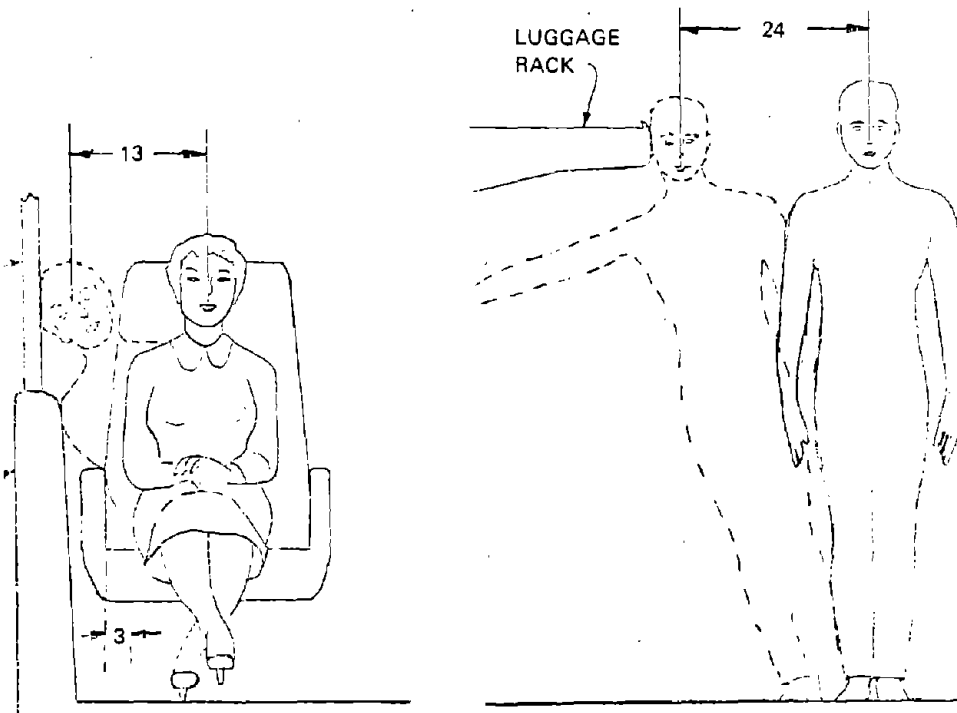
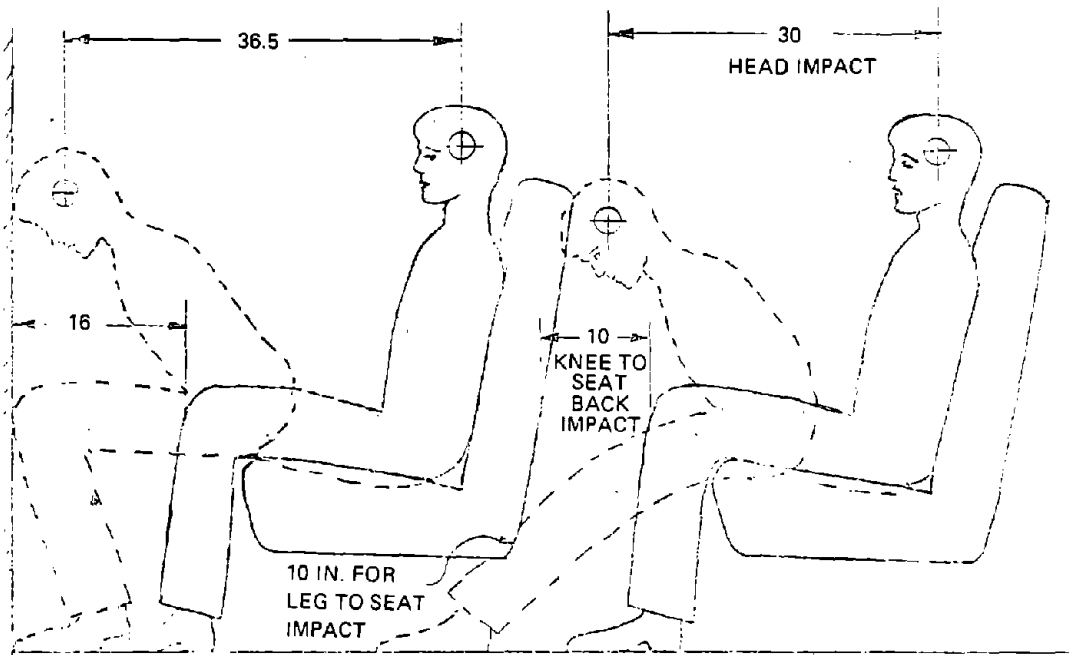

Figure 5-27. Passenger Railcar Collision Occupant Impacts

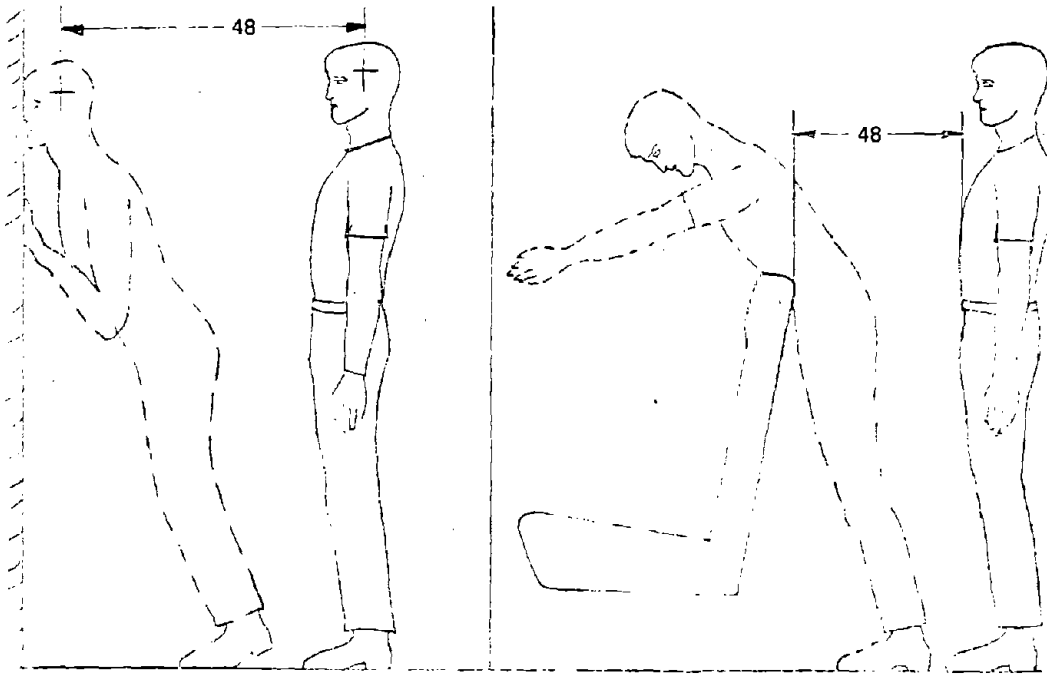

Figure 5-27. Passenger Railcar Collision Occupant Impacts (Continued)

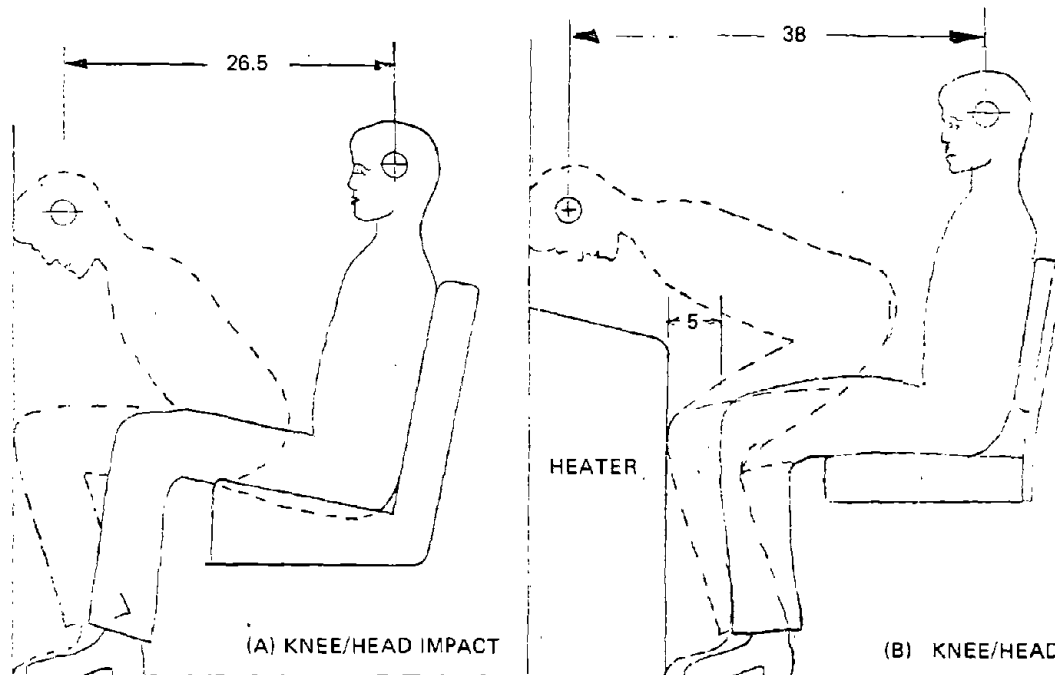

Figure 5-28. Locomotive Collision Occupant Impacts

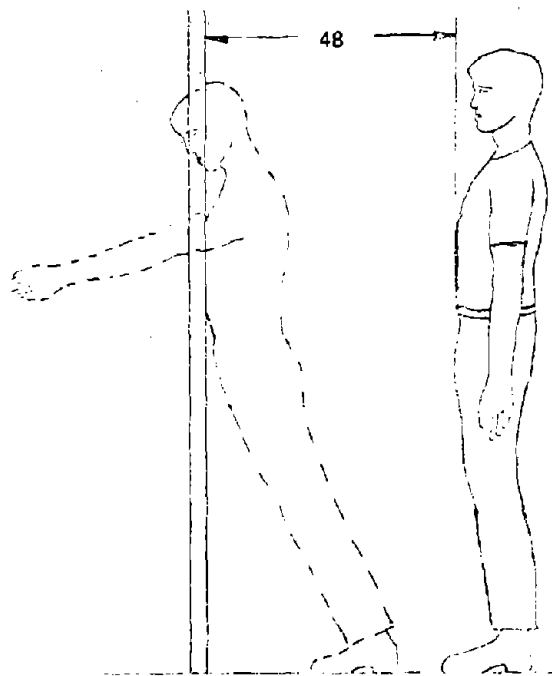
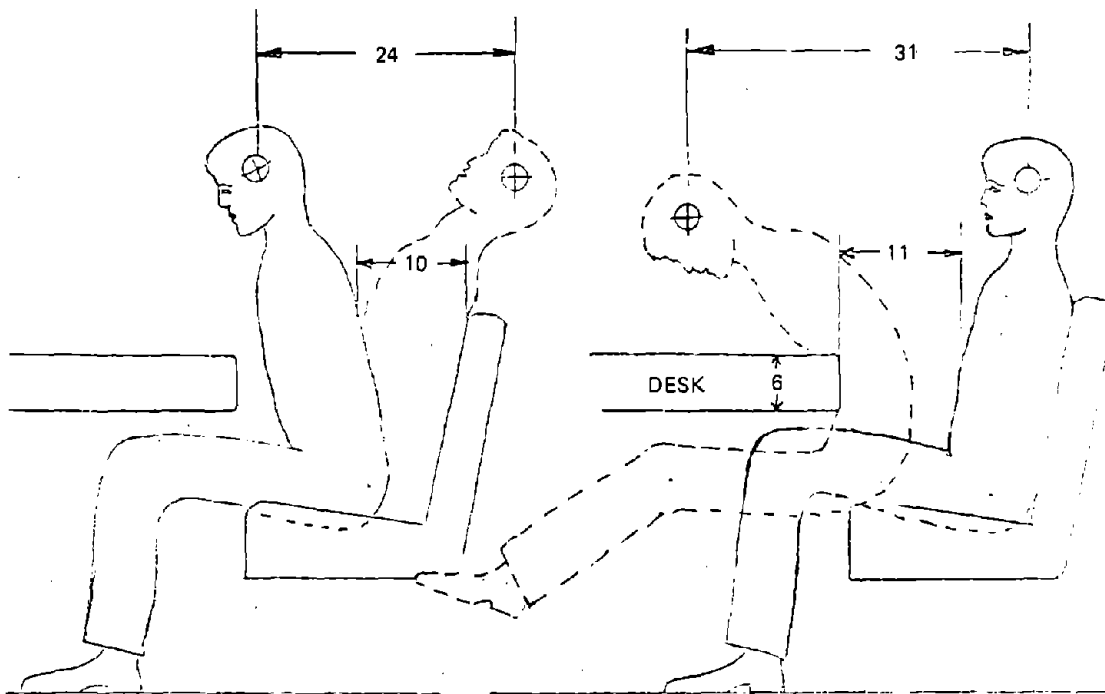

Figure 5-29. Caboose Collision Occupant Impacts

TABLE 5-1. LOCOMOTIVE COLLISION INJURY MATRIX

Collision Conditions	Injury Mechanism	Impact Surface Properties	Injury Potential	Modifications For Minor or No Injury
10 to 80 MPH Occupant, Impact Vel. 220 in./sec	Fireman's Head into Door from 26.5 in.	5/8 inch Safety Glass K=10,000 lb/in.	Severe to Fatal >500 lb/in. ² H.I.C. 1160	Restraint System or 4.5 in. Padded Buffer with Effective Cushion (Stiffness) of 280 lb/in.
10 to 80 MPH Occupant Impact Vel. 120 in./sec	Fireman's Knees into Door from 9 in.	Steel Plate Door K=3000 lb/in.	Moderate to Severe 1200 lb (300 lb/in. ²) Force on Knee	Same as above
10 to 80 MPH Impact Vel. 235 in./sec	Engineman's Head into Window from 38 in.	5/8 inch Safety Glass K=10,000 lb/in.	Severe to Fatal >500 lb/in. ² H.I.C. >1000	Same as above
10 to 80 MPH Impact Vel. 170 in./sec	Engineman's Knees into Heater from 5 in.	Sheet Steel Construction K=600 lb/in.	Minor to Moderate 600 lb/in. ²	Same as above

K = Deflection Stiffness (lb/in.)
 δ = Deflection (in.)

TABLE 5-2. CABOOSE COLLISION INJURY MATRIX

Collision Conditions	Injury Mechanism	Impact Surface Properties	Injury Potential	Modifications For Minor or No Injury
10 to 80 MPH Forward Acceleration	Chest into 6 in. Desk from 11 in.	Padded Face K=3000 lb/in. $\delta=1$ in.	Moderate to Severe >60 G/3ms	Restraint System or Chest Buffer with 80 in. ² Contact Area
10 to 80 MPH Rearward Acceleration	Occupant into Seat Back	Low Seat Back	Moderate to Severe Neck Hyperextension (Whiplash)	High Seat Back with Headrest
10 to 80 MPH Longitudinal Occupant Acceleration 165 in./sec	Torso into Stantion from 48 in. 10 in. ² Contact Area	Vertical Steel Stantion K=107 lb/in. $\delta=5.56$ in.	Minor to Moderate 12 G over Sustained Time	Replace Vertical Stantions with Horizontal Recessed Grab Rail

K = Deflection Stiffness (lb/in.)
 δ = Deflection (in.)

TABLE 5-3. PASSENGER RAILCAR COLLISION INJURY MATRIX

Collision Conditions	Injury Mechanism	Impact Surface Properties	Injury Potential	Modifications For Minor or No Injury
10 to 80 MPH Occupant Impact Vel. 95 in./sec	Frontal Head Striking Partition From 36.5 in. 8 in. 2 Contact Area	Sheetmetal Over Sheetmetal Former Stiffness 3000 lb/in. Penetration 0.4 in.	Minor Injury 148 lb/in. 2 Skull Pressure H.I.C. 27	Reduce Stiffness or Add Padding
10 to 80 MPH Occupant Impact Vel. 95 in./sec	Side of Head Striking Partition From 36.5 in. 3 in. 2 Contact Area	Sheetmetal Over Sheetmetal Formers Stiffness 3000 lb/in. Penetration 0.4 in.	Minor Injury 394 lb/in. 2 H.I.C. 27	Reduce Stiffness or Add Padding
10 to 80 MPH Occupant Impact Vel. 95 in./sec	Knees into Partitio From 16 in. 6 in. 2 contact Area	Sheetmetal Spanning Formers Stiffness 3000 lb/in.	Moderate Injury Knee Force 945 lb Pressure 157 lb/in. 2	Reduce Stiffness or Add Padding
10 to 80 MPH Occupant Impact Vel. 95 in./sec	Legs Wedged Under Forward Seat - 1 in. 2 Contact Area	Steel Member Across Seat Bottom	Leg Fracture Probable Force >1000 lbs	Add Seat Skirt to Prevent Leg Entrapment
10 to 80 MPH Occupant Impact Vel. 95 in./sec	Face/Head into Seat Back From 30 in.	Standard Padded Seat Back 580 lb/in. Stiffness	No Head Injury H.I.C. 3.5 60 lb/in. 2 Nose Injury Likely	Add Softer Padding to Top Back of Seat

TABLE 5-3 - Continued

Collision Conditions	Injury Mechanism	Impact Surface Properties	Injury Potential	Modifications For Minor or No Injury
Roll Over Occupant Impact Vel. 34 in./sec	Rib Impact with Armrest From 3 in. 4 in. ² Contact A	Rigid Armrest Unpadded K=1000 lb/in. ²	Rib Fracture Rib Pressure 60 lb/in. ²	Add Padding to Armrest
Roll Over Occupant Impact Vel. 34 in./sec	Side of Head Striking Window - 3 in. ² Contact Area	Safety Glass K=10,000 lb/in. ² 260 lb/in. ² to Fracture Penetration .08 in.	Minor Injury @ 13 in. H.I.C.=13 Serious Injury @60 in.HIC >500	Design Glass for Greater Deformation K=1000 Max
10 to 80 MPH Occupant Impact Vel. 150 in./sec	Standing Occupant Head into Door 8 in. ² Contact Area	Conventional Steel Panel Entrance Door 4000 lb/in. ² Stiffness Penetration 0.34 in.	Minor to Moderate 267 lb/in. Skull Pressure H.I.C. 125	Add Padding to Door or Design for Increased Deflection
10 to 80 MPH Occupant Impact Vel. 150 in./sec	Standing Occupant Rib Cage into Seat Back	Padded Seat Back 500 lb/in. ² Stiffness Penetration 2.45 in.	Minor Injury GADD 11.71	Increase Seat Back Padding
10 to 80 MPH Occupant Impact Vel. 136 in./sec	Standing Occupant Head into Luggage Rack Rail 3000 lb/in. ² Stiffness	Structural Member Along Edge of Luggage Rack Penetration 0.56 in.	Minor to Moderate 210 lb/in. Skull Pressure H.I.C. 82	Add Padding to Luggage Rack Rail

K = Deflection Stiffness (lb/in.)
 δ = Deflection (in.)

5.3 RAIL VEHICLE INTERIOR DELETHALIZATION

Rail car delethalization is applicable to locomotives, cabooses, and passenger cars. The degree of delethalization necessary depends on the degree of restraint or confinement provided for the occupant. An occupant fully restrained to a seat or confined to an area by buffers and padded surfaces will not strike lethal objects outside of the confined area. However, occupants (passengers or trainmen) are sometimes out of their seats while the train is in motion, and, if accelerated while away from their seats, may strike hazardous objects. Occupants may also be injured due to being struck by loose objects or objects torn loose during a collision. In addition, occupants may be burned or overcome by toxic fumes from burning materials within the rail vehicle.

5.3.1 Delethalized Surfaces

Surfaces or objects can be rendered safe for impact by the following techniques:

- Shrouding
- Paneling
- Shielding
- Recessing
- Compartmenting
- Padding
- Remoting
- Fragmenting
- Eliminating

5.3.1.1 Shrouding

Shrouding can be used to provide a smooth or load-distributing surface covering an item which in itself cannot be made without sharp corners or projections. Shrouding can take the form of an external pan covering or panel. Pan covers may be placed over components which do not require access for normal operation. Such a covering as shown for a windshield wiper motor in Figure 5-30.

5.3.1.2 Paneling

Protection from impact with large irregular surfaced or

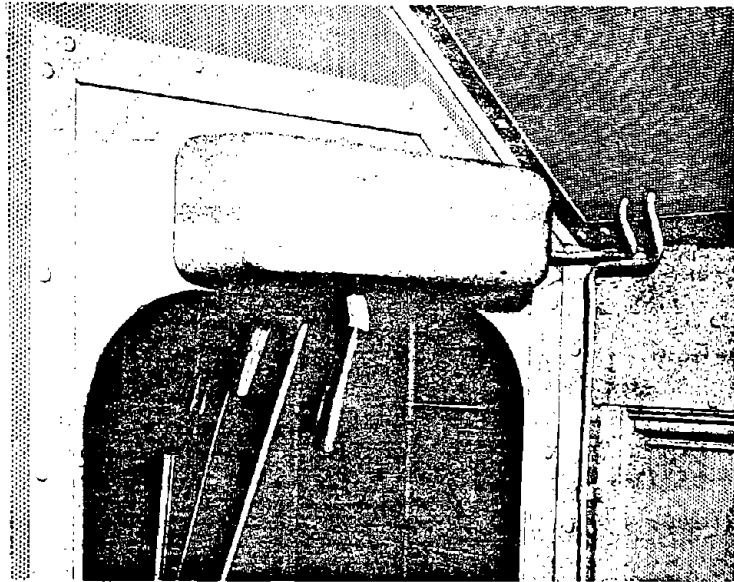

Figure 5-30. Shielded Windshield Wiper Motor

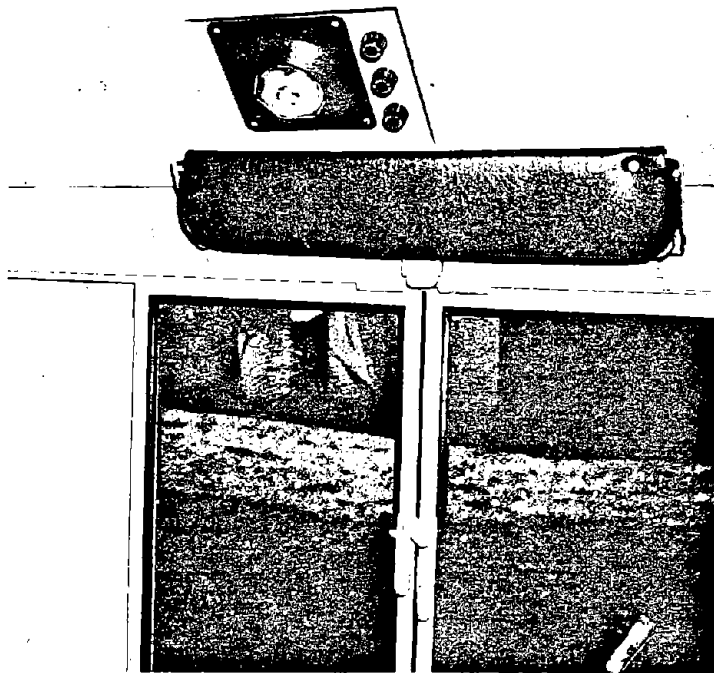

Figure 5-31. Recessed Light Panel

high temperature equipment can be accomplished with paneling. Flush panels may be used to cover heaters, stoves, fuel tanks, water tanks, water coolers, etc. Grills may be used in the panels, if required, for air circulation to such equipment as space heaters or refrigeration equipment. Panels can be hinged or doors can be added as necessary to provide service access to the equipment. Operational access to such items as a water cooler can be accomplished by providing a hole in the panel in which the spigot is recessed.

5.3.1.3 Shielding

Shielding may be employed to provide a load-distributing surface for the impacting occupant around protruding controls and handles which cannot otherwise be recessed, and require access for operation. A sample shield around locomotive control console handles is shown in Figure 5-18. Clearance around the handles must be sufficient to allow unencumbered operation and visual reference. To distribute loads over an occupant's impacted body area and not cause injury, the shield may employ deformable materials or padding as necessary, depending on the orientation, area of impact, and distance from occupant. Energy-absorbing material design is discussed in paragraph 5.2.4.

5.3.1.4 Recessing

In new designs and where space and operational requirements permit in existing railcars, all small protruding items which can cause injury if impacted should be recessed in a flush panel. Items which can be recessed are limited to small articles. The item should be recessed in a manner to present a flush area around the item for sufficient load distribution over the body area impacted. In determining the maximum size of the recess, consideration should be given to the relationship of the location and the probable body areas which will span the recess during impact. Narrow recesses are better than square recesses and should be oriented perpendicular to the probable body impact direction. Figure 5-31 shows a recessed light fixture and windshield wiper controls. All door knobs, handles, window latches and other small protuberances must be recessed or flush with mounting surface.

5.3.1.5 Compartmenting

The present practice of hanging such items as fire extinguishers, first-aid kits, towel dispensers, control handle stowage racks, and fusee and torpedo boxes on bulkheads should be avoided. Compartments with flush doors (marked with the contents) should be provided. Doors should be designed so they will not swing open under collision accelerations. Latches for securing the doors and handles should be flush with the face of the doors.

5.3.1.6 Padding

Equipment which cannot be shielded, recessed, or stowed in compartments and will therefore present an impact hazard to occupants should have their corners rounded to the maximum extent practical and should be padded.

5.3.1.7 Remoting and Fragmenting

Some protuberances such as control handles are impractical to pad. Several methods can be considered to render them safe from injury due to impact. One is the shield method described previously. Another, more costly, approach is to provide a remote control system and eliminate the handles. Electrical switches or buttons in a flush panel can be employed to activate remote actuators. This method provides the safest control system, from an injury minimization standpoint. A less costly approach is to use conventional manual controls which are frangible. Impact against these handles would cause them to break off or bend at a load below the injury threshold. The difficulty becomes one of designing to balance the breaking load to prevent injury against breakage due to normal operation.

5.3.1.8 Eliminating

Interior furnishings which can not be made safe for occupant impact should be eliminated if at all possible. Substitute methods should be found to perform a necessary function without use of an item which could cause injury. Such an example is window shades. Such shades used in passenger cars contain a metal rod or bar at the bottom for stiffening the shade. In a collision, if the shade becomes loose from its track, it can become lethal. Substitutes such as tinted window glass could be used to eliminate shades. Foot rests are another source of injury which should be eliminated, if possible. Where necessary the foot rest should be designed so that the foot can not be trapped below the foot rest.

5.3.2 Equipment Securement

Whether or not they are permanently bolted to the railcar structure, equipment such as control consoles, water coolers, refrigerators, water tanks, and heaters, or portable equipment such as fire extinguishers, first-aid kits, and luggage should be provided with adequate securement to withstand collision impacts. Impact requirements for various types of rail cars are discussed in paragraph 3.1. Permanently attached equipment should be designed to withstand a load five times its weight without failing its attachments for accelerations in the longitudinal directions, and three times its weight in lateral and vertical directions in locomotives and passenger cars. Caboose

equipment should be designed for 15-g longitudinal and 5-g lateral loading.

Portable train equipment should be provided with sturdy clamps to secure them in their stowed positions. The clamps should not be subject to distortion or failure as a result of repeated operations. The design strength should be the same as that for permanent equipment. Equipment capable of being stowed in more than one orientation should be designed to withstand the highest loading in all orientations.

Loose baggage is a source of injury in passenger car collisions. Luggage racks usually are open on the sides with no restraints provided. Airlines prohibit placement of parcels or luggage in the overhead racks. Newer airliners have doors on the overhead racks to secure briefcases, packages, and other hard objects previously not permitted in overhead racks. Similar doors should be provided on passenger railcar luggage racks. The doors can be hinged at the top or bottom and latched on the opposite side. Doors with latches should be designed to withstand a load in the lateral direction of 150 pounds per square foot without excessive deformation or failure. Baggage racks should be compartmented in the longitudinal direction into units not exceeding six feet. The compartment dividers should be designed for a distributed load of 1500 pounds.

5.3.3 Material Selection

Materials selected for occupied railcar interiors should be flame retardant and antitoxant. All nonmetallic materials and paint properties should be checked before use by reviewing the Transportation Systems Center Material Data Bank Catalog, DOT-TSC-926-3.

5.3.4 Glazing

The design of glazing for rail vehicle occupant safety must not only consider the softness or resilience of the glass to reduce occupant injury when impacted but the rigidity of the glass to prevent occupant ejection through the glass and foreign object penetration into the rail vehicle. A compromise must be reached between these opposing requirements. In addition to these requirements consideration must be given to design for air pressure at top speeds, shock due to passing other trains, shocks due to entering and exiting tunnels and all other pertinent stress and strains.

Location of the glass in the rail vehicle and the probability of occupant impact with the glass will also have a bearing on the design. Glass used in windshields of locomotives must be designed for the pressures of forward maximum speeds and

also to prevent penetration by impact of large foreign objects such as a concrete block hung or dropped from an overpass by vandals. Design for these requirements will predominate. Occupant impact requirements should be disregarded as the locomotive occupants should be provided with restraint or containment devices to prevent impact with the windshield.

Glazing in cabooses at brakeman observation posts which face in a forward direction, and rearward direction if the caboose can be operated in both directions, should be designed for the pressures of maximum forward speeds for freight trains and must also meet the impact requirements from large foreign objects. Occupant impact safety requirements can be disregarded if restraint or containment systems are provided at the observation posts.

Passenger railcar side windows must meet the requirements for pressure and shock requirements previously discussed. In addition they must be designed to withstand without penetration from the outside, the impact of objects of the size, density, weight and hardness of a standard baseball impacting at 75 ft/sec. Maximum retention of shattered particles shall be provided for. The glass must also be designed to yield when an occupant's head impacts at the center for a minimum deflection of 1.5 inches at a velocity of 150 in./sec or a maximum spring rate of 1000 lb/in. The window glass and sash retainer must be designed to prevent ejection of a 200 pound occupant impacting the glass at 150 in./sec.

Glass in passenger railcar interior doors, lavatories and partitions should be designed primarily for the prevention of injury to occupants during impact. The glass should be designed to yield a minimum of 1.5 inches with an force of 1000 pound applied over a 12 square inch area. A membrane should be used in the glass to retain the integrity of the glass as a barrier in preventing occupant penetration through the glass. Maximum retention of shattered glass granules should be provided for.

REFERENCES

1. Melvin, J.W., and Evans, F.G., "A STRAIN ENERGY APPROACH TO THE MECHANICS OF SKULL FRACTURE," Proceedings of the Fifteenth Stapp Car Crash Conference, November 1971, SAE Paper No. 710871.
2. Nahum, A.M., Gatts, J.D., Gadd, C.W., and Danforth, J., "IMPACT TOLERANCE OF THE SKULL AND FACE," Proceedings of the Twelfth Stapp Car Crash Conference, October 1968, SAE Paper No. 680785.
3. Hodgson, V.R., Brinn, J., Thomas, L.M., and Greenberg, S.W., "FRACTURE BEHAVIOR OF THE SKULL FRONTAL BONE AGAINST CYLINDRICAL SURFACES," Proceedings of the Fourteenth Stapp Car Crash Conference, November 1970, SAE Paper No. 700909.
4. Schneider, D.C., and Nahum, A.M., "IMPACT STUDIES OF FACIAL BONES AND SKULL," Proceedings of the Sixteenth Stapp Car Crash Conference, Detroit, Michigan, November 1972.
5. Hodgson, V.R., "TOLERANCE OF THE FACIAL BONES TO IMPACT," The American Journal of Anatomy, Dempster Memorial Issue, Vol. 120, No. 1, pp. 113-122, January 1967.
6. Patrick, L.M., Lange, W.A., and Hodgson, V.R., "FACIAL INJURIES - CAUSES AND PREVENTION," Proceedings of the Seventh Stapp Car Crash Conference, Charles C. Thomas (Publisher), Springfield, Illinois, 1965.
7. Patrick, L.M., and Mertz, H.J., "CADAVER KNEE, CHEST AND HEAD IMPACT LOADS," Proceedings of the Eleventh Stapp Car Crash Conference, October 1967, Anaheim, California, SAE Paper No. 670913.
8. Patrick, L.M., Kroell, C.K., and Mertz, H.J., "FORCES ON THE HUMAN BODY IN SIMULATED CRASHES," Proceedings of the Ninth Stapp Car Crash Conference, Nolte Center for Continuing Education, University of Minnesota, 1966.
9. Mertz, H.J., "THE KINEMATICS AND KINETICS OF WHIPLASH", Ph.D. Dissertation, Wayne State University, 1967.
10. Mertz, H.J., and Patrick, L.M., "INVESTIGATION OF THE KINEMATICS AND KINETICS OF WHIPLASH," Proceedings of the Eleventh Stapp Car Crash Conference, Society of Engineers, Inc., New York, 1967.

11. Mertz, J.J., and Patrick, L.M., "STRENGTH AND RESPONSE OF THE HUMAN NECK," Proceedings of the Fifteenth Stapp Car Crash Conference, Coronado, California, November 17-19, 1971, SAE Paper No. 710020.
12. Kramer, M., Burow, K., and Heger, A., "FRACTURE MECHANISM OF LOWER LEGS UNDER IMPACT LOAD," Proceedings of Seventeenth Stapp Car Crash Conference, November 12-13, Oklahoma City, Oklahoma, SAE Paper No. 730966.
13. Young, J.W., "THRESHOLD VALUE FOR TIBIA FRACTURE, MALE CADAVERS (AGED 29-57)," 1967 (unpublished).
14. Kroell, C.H., Schneider, D.C., and Nahum, A.M., "IMPACT TOLERANCE AND RESPONSE OF THE HUMAN THORAX II," Proceedings of Eighteenth Stapp Car Crash Conference, Ann Arbor, Michigan, December 4-5, 1974, SAE Paper No. 741187.
15. Title 49, Code of Federal Regulations Part 571.201, Occupant Protection in Interior Impacts, Motor Vehicle Safety Standards, National Highway Traffic Safety Administration, Department of Transportation, Washington, D.C.
16. Reilly, M.J., "CRASHWORTHY TROOP SEAT INVESTIGATION," The Boeing Vertol Company, Technical Report 74-93, U.S. Army Air Mobility Research and Development Laboratory, Fort Eustis, Virginia, 23604, December 1974.
17. CRASH SURVIVAL DESIGN GUIDE, Dynamic Science, USAAMRDL Technical Report 71-22, U.S. Army Air Mobility Research and Development Laboratory, Fort Eustis, Virginia, 23604, October 1971.
18. Robinson, J., et al, "LOCOMOTIVE CAB DESIGN DEVELOPMENT," Boeing Vertol Company, DOT-TSC-913-3, Department of Transportation, Transportation Systems Center, Cambridge, Mass., August 1975.

APPENDIX - NEW TECHNOLOGY

No innovation, discovery, or invention was made in the performance of this study. However, some improvements are noted. For example, in Section 5, pages 33ff, protective-design considerations are presented for the first time for locomotives, passenger cars, and cabooses relating to the rail-vehicle interiors and crashworthiness.

