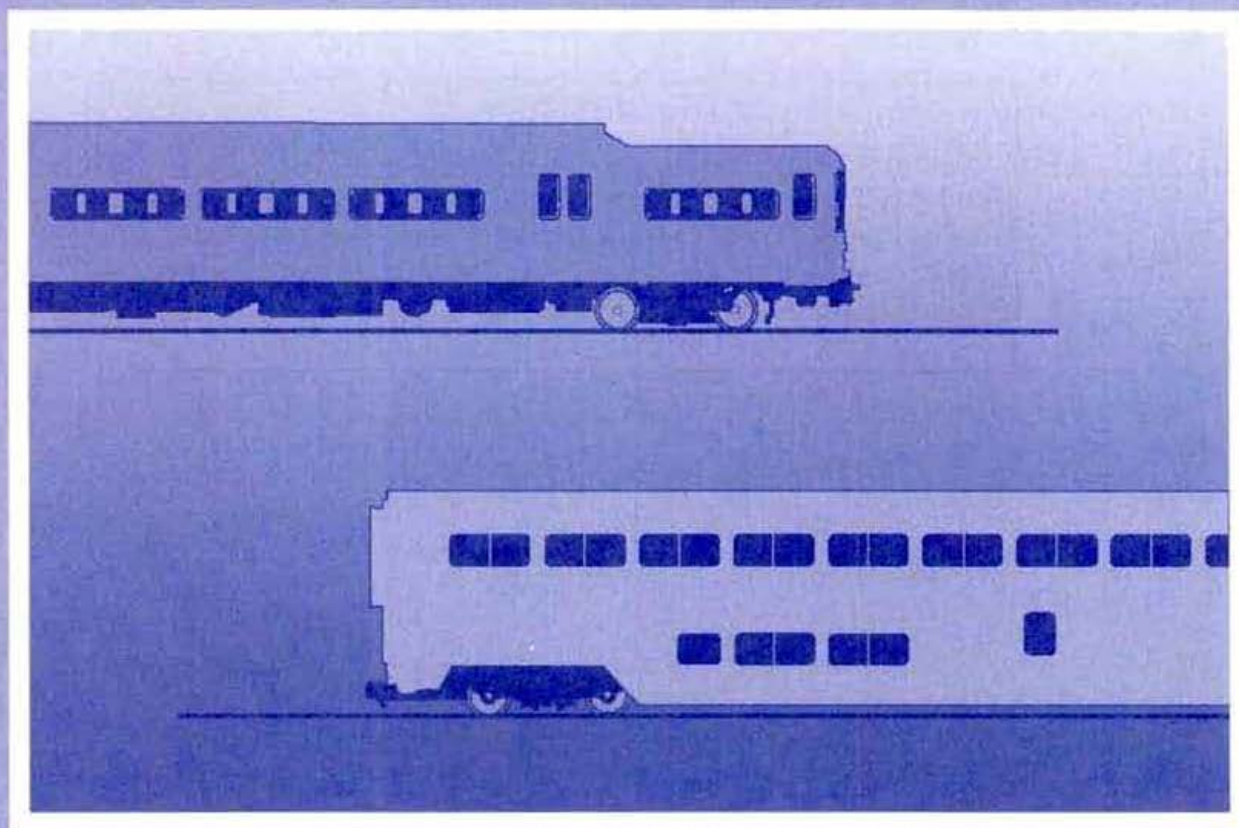




U.S. Department  
of Transportation  
**Federal Railroad  
Administration**

# Design Data on Suspension Systems of Selected Rail Passenger Cars

Office of Research  
and Development  
Washington, DC 20590



DOT/FRA/ORD-96-01  
DOT-VNTSC-FRA-95-5

Final Report  
July 1996

This document is available to the  
public through the National Technical  
Information Service, Springfield, VA 22161

Rail Vehicles &  
Components

**NOTICE**

This document is disseminated under the sponsorship of the Department of Transportation in the interest of information exchange. The United States Government assumes no liability for its contents or use thereof.

**NOTICE**

The United States Government does not endorse products or manufacturers. Trade or manufacturers' names appear herein solely because they are considered essential to the objective of this report.

# REPORT DOCUMENTATION PAGE

*Form Approved*  
**OMB No. 0704-0188**

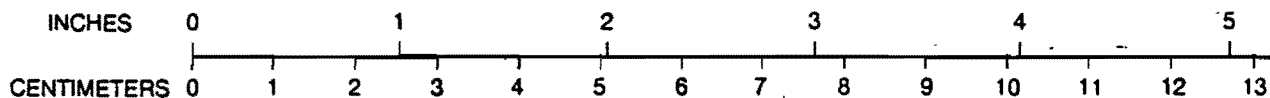
Public reporting burden for this collection of information is estimated to average 1 hour per response, including the time for reviewing instructions, searching existing data sources, gathering and maintaining the data needed, and completing and reviewing the collection of information. Send comments regarding this burden estimate or any other aspect of this collection of information, including suggestions for reducing this burden, to Washington Headquarters Services Directorate for Information Operations and Reports, 1215 Jefferson Davis Highway, Suite 1204, Arlington, VA 22202-4302, and to the Office of Management and Budget, Paperwork Reduction Project (0704-0188), Washington, DC 20503.

<b>1. AGENCY USE ONLY (Leave blank)</b>	<b>2. REPORT DATE</b> July 1996	<b>3. REPORT TYPE AND DATES COVERED</b> Final Report October 1993-December 1994	
<b>4. TITLE AND SUBTITLE</b> Design Data on Suspension Systems of Selected Rail Passenger Cars		<b>5. FUNDING NUMBERS</b> RR 593/R 5021	
<b>6. AUTHORS</b> Alan J. Bing, Shaun R. Berry and Hal B. Henderson			
<b>7. PERFORMING ORGANIZATION NAME(S) AND ADDRESS(ES)</b> Arthur D. Little, Inc.* Acorn Park Cambridge, MA 02140		<b>8. PERFORMING ORGANIZATION REPORT NUMBER</b> DOT-VNTSC-FRA-95-5	
Parsons Brinckerhoff Quade and Douglas, Inc.* 120 Boylston Street Boston, MA 02116			
<b>9. SPONSORING/MONITORING AGENCY NAME(S) AND ADDRESS(ES)</b> U.S. Department of Transportation Federal Railroad Administration Office of Research and Development Washington, D.C. 20590		<b>10. SPONSORING/MONITORING AGENCY REPORT NUMBER</b> DOT/FRA/ORD-96-01	
<b>11. SUPPLEMENTARY NOTES</b> *Under contract to U.S. Department of Transportation Volpe National Transportation Systems Center Kendall Square, Cambridge, MA 02142			
<b>12a. DISTRIBUTION/AVAILABILITY STATEMENT</b> This document is available to the public through the National Technical Information Service, Springfield, VA 22161 (Tel: 703-487-4634)		<b>12b. DISTRIBUTION CODE</b>	
<b>13. ABSTRACT (Maximum 200 words)</b>  This report presents the results of an effort to compile data for the U.S. fleet of railroad passenger cars, and to describe the different passenger car truck designs and design features used in the United States.  The report provides a detailed discussion of the functions of a rail passenger car truck, and how different truck designs and truck components are selected to perform the functions. Both the two-axle truck normally applied to rail passenger cars and truck designs with additional or alternative features (such as car body tilt, articulation, and single-axle trucks) are described.  A full listing of passenger cars and truck designs in service in the United States is provided. Detailed descriptions and engineering data, to the extent available, are provided on eight selected truck designs representative of the majority of trucks in service. The truck data include a general description of the truck, the mass and inertias of principal truck components (wheelset, truck frame, bolster), spring stiffnesses and damping rates, and the car body mass, inertia, and truck to car body interface characteristics. Information is also provided on the service environment in which the truck operates, and on maintenance history.			
<b>14. SUBJECT TERMS</b> Rail transportation, rail passenger cars, passenger car trucks, rail vehicle dynamics, vehicle-track interaction, bogies		<b>15. NUMBER OF PAGES</b> 192	
		<b>16. PRICE CODE</b>	
<b>17. SECURITY CLASSIFICATION OF REPORT</b> Unclassified	<b>18. SECURITY CLASSIFICATION OF THIS PAGE</b> Unclassified	<b>19. SECURITY CLASSIFICATION OF ABSTRACT</b> Unclassified	<b>20. LIMITATION OF ABSTRACT</b>

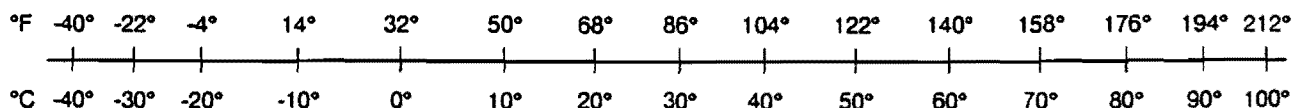
## METRIC/ENGLISH CONVERSION FACTORS

ENGLISH TO METRIC	METRIC TO ENGLISH
<p style="text-align: center;"><b>LENGTH (APPROXIMATE)</b></p> <p>1 inch (in) = 2.5 centimeters (cm)                      1 foot (ft) = 30 centimeters (cm)                      1 yard (yd) = 0.9 meter (m)                      1 mile (mi) = 1.6 kilometers (km)</p>	<p style="text-align: center;"><b>LENGTH (APPROXIMATE)</b></p> <p>1 millimeter (mm) = 0.04 inch (in)                      1 centimeter (cm) = 0.4 inch (in)                      1 meter (m) = 3.3 feet (ft)                      1 meter (m) = 1.1 yards (yd)                      1 kilometer (km) = 0.6 mile (mi)</p>
<p style="text-align: center;"><b>AREA (APPROXIMATE)</b></p> <p>1 square inch (sq in, in<sup>2</sup>) = 6.5 square centimeters (cm<sup>2</sup>)                      1 square foot (sq ft, ft<sup>2</sup>) = 0.09 square meter (m<sup>2</sup>)                      1 square yard (sq yd, yd<sup>2</sup>) = 0.8 square meter (m<sup>2</sup>)                      1 square mile (sq mi, mi<sup>2</sup>) = 2.6 square kilometers (km<sup>2</sup>)                      1 acre = 0.4 hectare (ha) = 4,000 square meters (m<sup>2</sup>)</p>	<p style="text-align: center;"><b>AREA (APPROXIMATE)</b></p> <p>1 square centimeter (cm<sup>2</sup>) = 0.16 square inch (sq in, in<sup>2</sup>)                      1 square meter (m<sup>2</sup>) = 1.2 square yards (sq yd, yd<sup>2</sup>)                      1 square kilometer (km<sup>2</sup>) = 0.4 square mile (sq mi, mi<sup>2</sup>)                      10,000 square meters (m<sup>2</sup>) = 1 hectare (ha) = 2.5 acres</p>
<p style="text-align: center;"><b>MASS - WEIGHT (APPROXIMATE)</b></p> <p>1 ounce (oz) = 28 grams (gm)                      1 pound (lb) = .45 kilogram (kg)                      1 short ton = 2,000 pounds (lb) = 0.9 tonne (t)</p>	<p style="text-align: center;"><b>MASS - WEIGHT (APPROXIMATE)</b></p> <p>1 gram (gm) = 0.036 ounce (oz)                      1 kilogram (kg) = 2.2 pounds (lb)                      1 tonne (t) = 1,000 kilograms (kg) = 1.1 short tons</p>
<p style="text-align: center;"><b>VOLUME (APPROXIMATE)</b></p> <p>1 teaspoon (tsp) = 5 milliliters (ml)                      1 tablespoon (tbsp) = 15 milliliters (ml)                      1 fluid ounce (fl oz) = 30 milliliters (ml)                      1 cup (c) = 0.24 liter (l)                      1 pint (pt) = 0.47 liter (l)                      1 quart (qt) = 0.96 liter (l)                      1 gallon (gal) = 3.8 liters (l)                      1 cubic foot (cu ft, ft<sup>3</sup>) = 0.03 cubic meter (m<sup>3</sup>)                      1 cubic yard (cu yd, yd<sup>3</sup>) = 0.76 cubic meter (m<sup>3</sup>)</p>	<p style="text-align: center;"><b>VOLUME (APPROXIMATE)</b></p> <p>1 milliliter (ml) = 0.03 fluid ounce (fl oz)                      1 liter (l) = 2.1 pints (pt)                      1 liter (l) = 1.06 quarts (qt)                      1 liter (l) = 0.26 gallon (gal)                      1 cubic meter (m<sup>3</sup>) = 36 cubic feet (cu ft, ft<sup>3</sup>)                      1 cubic meter (m<sup>3</sup>) = 1.3 cubic yards (cu yd, yd<sup>3</sup>)</p>
<p style="text-align: center;"><b>TEMPERATURE (EXACT)</b></p> <p style="text-align: center;">[(x - 32)(5/9)]°F = y°C</p>	<p style="text-align: center;"><b>TEMPERATURE (EXACT)</b></p> <p style="text-align: center;">[(9/5)(y + 32)]°C = x°F</p>

### QUICK INCH-CENTIMETER LENGTH CONVERSION



### QUICK FAHRENHEIT-CELSIUS TEMPERATURE CONVERSION



For more exact and or other conversion factors, see NIST Miscellaneous Publication 286, Units of Weights and Measures. Price \$2.50. SD Catalog No. C13 10286.

Updated 9/29/95

## PREFACE

In recent years, there has been a resurgence of interest in expanding railroad passenger service in the United States. The interest has encompassed both intercity service and, especially, commuter service around large cities. Several factors have combined to create this interest, including a need to reduce airport and highway congestion, and to reduce air pollution in some regions of the country. The attractiveness of passenger rail is enhanced by the ability to make use of existing railroad rights-of-way to initiate service quickly and at relatively modest cost compared with other options for improving local and regional public transportation.

A consequence of this interest is a substantial and growing investment in new railroad passenger cars (as distinct from heavy rail mass transit and light rail cars) for operation in the United States. About 200 new railroad passenger cars are purchased each year. In an effort to improve car performance and productivity, these purchases are likely to include car and truck designs not previously used in the United States. In the past there have been problems with newly introduced car designs: as an example, the cars may encounter operational or track conditions not considered in the design. It is necessary to perform engineering analysis to resolve such problems, and also to perform proactive evaluations of novel truck and car designs to ensure that safety and performance goals are being met. This report presents engineering descriptions and data on selected railroad passenger cars and trucks to support these analyses and evaluations.

The report was prepared by Arthur D. Little, Inc., together with Parsons Brinckerhoff Quade and Douglas, Inc. as subcontractor to Arthur D. Little, under Contract Number DTS-57-93-D-00036 with the John A. Volpe National Transportation Systems Center (Volpe Center). The Federal Railroad Administration, Office of Research and Development was the sponsor of the study.

The authors of the study wish to express their appreciation to Harvey Lee (the project manager for this effort), David Tyrell and Herbert Weinstock of the Volpe Center and Tom Tsai of the Federal Railroad Administration for their assistance and support throughout the study and for helpful comments on the draft report, and to Ronald Mayville at Arthur D. Little and Mike Sadler at Parsons Brinckerhoff. The authors would also like to thank the numerous representatives of U.S. intercity and commuter rail authorities and passenger car and truck manufacturers who provided information and assistance throughout the study.



## TABLE OF CONTENTS

<b>Section</b>	<b>Page</b>
EXECUTIVE SUMMARY .....	ix
1. INTRODUCTION .....	1-1
1.1 BACKGROUND .....	1-1
1.2 PRIOR WORK .....	1-2
1.3 OBJECTIVES OF THE STUDY .....	1-3
1.4 CONTENTS OF THE REPORT .....	1-4
2. OVERVIEW OF RAIL PASSENGER CAR TRUCK DESIGN .....	2-1
2.1 INTRODUCTION .....	2-1
2.1.1 Background .....	2-1
2.1.2 Definitions .....	2-1
2.2 FUNCTIONS OF A RAIL PASSENGER CAR SUSPENSION .....	2-4
2.2.1 Overview .....	2-4
2.2.2 Support .....	2-5
2.2.3 Guidance and Stability .....	2-6
2.2.4 Isolation .....	2-10
2.2.5 Suspension Mounted Equipment .....	2-13
2.3 CONVENTIONAL 2-AXLE TRUCK DESIGNS .....	2-19
2.3.1 Introduction .....	2-19
2.3.2 Primary Suspension Configurations .....	2-19
2.3.3 Secondary Suspension Configurations .....	2-26
2.4 TRUCK AND CAR DESIGNS WITH SPECIALIZED FEATURES .....	2-33
2.4.1 Bi-Level Car Body Designs .....	2-33
2.4.2 Articulated Trainsets .....	2-35
2.4.3 Single-Axle Trucks .....	2-35
2.4.4 Independent Wheel Suspensions .....	2-38
2.4.5 Steering Trucks .....	2-38
2.4.6 Body Tilt Suspensions .....	2-41

**TABLE OF CONTENTS (Continued)**

<b><u>Section</u></b>	<b><u>Page</u></b>
3. SUMMARY DESCRIPTIONS AND DATA FOR MAJOR AND DISTINCTIVE TRUCK DESIGNS .....	3-1
3.1 INTRODUCTION .....	3-1
3.2 CLASSIFICATION OF TRUCK DESIGNS .....	3-1
3.3 TRUCK POPULATION DATA .....	3-8
3.4 SUMMARY TRUCK DESCRIPTIONS AND DATA .....	3-10
3.4.1 Choice of Truck Designs for Detailed Descriptions .....	3-10
3.4.2 Methodology and Data Sources for Truck Data .....	3-14
APPENDIX 1 DETAILED PASSENGER CAR TRUCK DATA AND DESCRIPTIONS .....	A1-1
APPENDIX 2 PASSENGER CAR POPULATION DATA .....	A2-1
REFERENCES .....	R-1



## LIST OF FIGURES

<b>Figure</b>		<b>Page</b>
Figure 2.1	Parts of a Typical Truck .....	2-2
Figure 2.2	Conventional Rail Vehicle Curving .....	2-7
Figure 2.3	Dynamic Stability .....	2-9
Figure 2.4	Ride Quality Standards: ISO 2631 Reduced Proficiency Boundaries for Vertical Accelerations on Standing or Seated Person .....	2-12
Figure 2.5	Alternative Brake Arrangements .....	2-15
Figure 2.6	Traction Motor Arrangements .....	2-17
Figure 2.7	Transmission Shaft Drive Through Right-Angle Gearbox .....	2-18
Figure 2.8	Journal - Bearing Arrangements .....	2-20
Figure 2.9	Flexible or Articulated Truck Frames .....	2-22
Figure 2.10	Equalizer Beam Primary Suspension .....	2-23
Figure 2.11	Primary Suspension and Journal Bearing Arrangements .....	2-25
Figure 2.12	Secondary Suspension Arrangements .....	2-27
Figure 2.13	Secondary Suspension Arrangements .....	2-28
Figure 2.14	Suspension Components .....	2-30
Figure 2.15	Bi-Level Car Layout .....	2-34
Figure 2.16	Articulation Arrangements .....	2-36
Figure 2.17	Single-Axle Suspensions .....	2-37
Figure 2.18	Talgo Suspension System Showing Independent Wheels .....	2-39
Figure 2.19	Truck Axle Steering Systems .....	2-40
Figure 2.20	Car Body Tilt System Arrangements .....	2-42
Figure 3.1	Schematics of Truck Types 21 and 22 .....	3-4
Figure 3.2	Schematics of Truck Types 31 and 32 .....	3-6
Figure 3.3	Schematics of Truck Types 41, 42 and 43 .....	3-7
Figure 3.4	Coordinate System for Non-articulated Railroad Passenger Car with Two 2-axle Trucks .....	3-15
Figure A1.1.1	Budd Pioneer III for Amtrak Cars - Exploded View .....	A1-4
Figure A1.1.2	Budd Pioneer III for Amtrak Cars - Schematic .....	A1-5
Figure A1.2.1	GSI Truck for MBTA Commuter Various Single-Level Cars - Exploded View .....	A1-17
Figure A1.2.2	GSI Truck for MBTA Commuter Various Single-Level Cars - Schematic .....	A1-18
Figure A1.3.1	GSI Truck for Budd M3 for Long Island RR - Exploded View .....	A1-30
Figure A1.3.2	GSI Truck for Budd M3 for Long Island RR - Schematic .....	A1-31
Figure A1.4.1	GSI Truck for Amtrak Superliner II - Exploded View .....	A1-43
Figure A1.4.2	GSI Truck for Amtrak Superliner II - Schematic .....	A1-44
Figure A1.5.1	Waggon Union MD76 for Amtrak Superliner 1 - Exploded View .....	A1-56
Figure A1.5.2	Waggon Union MD76 for Amtrak Superliner 1 - Schematic .....	A1-57
Figure A1.6.1	Kawasaki Truck for Kawasaki Bi-Level for MBTA - Exploded View ...	A1-68
Figure A1.6.2	Kawasaki Truck for Kawasaki Bi-Level for MBTA - Schematic .....	A1-69
Figure A1.7.1	Nippon Sharyo NT319 Truck for Marc Commuter - Exploded View ....	A1-80
Figure A1.7.2	Nippon Sharyo NT319 Truck for Marc Commuter - Schematic .....	A1-81
Figure A1.8.1	Comeng Truck for Long Island RR Tokyu Car Bi-Level Commuter Car - Exploded View .....	A1-93
Figure A1.8.2	Comeng Truck for Long Island RR Tokyu Car Bi-Level Commuter Car - Schematic .....	A1-94

## LIST OF TABLES

	<b>Page</b>
<b>Table</b>	
Table 3.1	Principal Truck Design Classifications . . . . . 3-3
Table 3.2	U.S. Rail Passenger Car Fleet by Operator . . . . . 3-9
Table 3.3	Car Population by Truck Classification and Model - Unpowered Cars . . . . . 3-11
Table 3.4	Car Population by Truck Classification and Model - Powered Cars . . . . . 3-12
Table 3.5	Truck and Car Combinations Selected for Detailed Study . . . . . 3-13
Table A2-1	Passenger Car Population Data by Operator . . . . . A2-3
Table A2-2	Passenger Car Population Data by Truck Classification . . . . . A2-7

## EXECUTIVE SUMMARY

In recent years, there has been a resurgence of interest in the United States in intercity and commuter railroad passenger services. Several factors have combined to create this interest, including a need to reduce airport and highway congestion in major cities, and to reduce air pollution and other adverse environmental impacts of heavy automobile traffic.

Commuter rail services are an attractive option for improving public passenger transportation in large urban areas. Services can be initiated quickly and cheaply using existing infrastructure, and can reach the outer suburbs of the cities where there are many potential riders. Improved intercity rail services are of continuing interest in many corridors, offering the potential to reduce airport congestion and to provide an attractive service in selected segments of the travel market. New and expanded commuter and intercity rail services are under active development in several regions, most notably in the Northeast Corridor, between Washington and Boston, in the Chicago area, and in various locations in California.

This interest has led to a substantial investment each year in new and refurbished railroad passenger cars in the United States. Over 600 cars are presently in operation in the United States, and new cars are being delivered at an annual rate of about 200 per year, representing an investment on the order of \$200 million.

These purchases are likely to include car and truck designs new to the United States that offer potential benefits in the form of higher speed capability, improved comfort, greater passenger capacity, and reduced capital and operating costs. However, experience suggests that such new designs are vulnerable to performance problems when first placed into service, for example due to the car and truck encountering track or other operational conditions not considered in the design. To reduce the risk of such problems, it is desirable to perform engineering evaluations of truck performance prior to finalizing car and truck design for a particular application. Such evaluations are particularly valuable when the cars or trucks embody novel features such as a tilt body or a radial truck. Also it is sometimes necessary to perform these evaluations to resolve safety problems with newly introduced truck and car designs.

One class of engineering evaluation of rail passenger car performance involves the application of computer analysis tools to investigate the car and truck dynamics, including track-train interaction, ride quality and derailment safety. To perform such analyses, data are required on the arrangement of cars and trucks used, on the mass and inertia of the car and truck components, and on truck suspension characteristics such as spring and damping rates.

At present much of these data is not readily available. Although a number of prior studies in this general area have been performed by agencies of the United States Department of Transportation, the data in these studies are either incomplete or outdated. This study was initiated to help fill the need for current truck and car data relevant to the analysis of rail passenger car and truck dynamics.

The specific contents of this report are as follows:

- A detailed discussion of the functions of a passenger car truck, and descriptions of the different mechanical arrangements used to perform the functions.
- Tabulations and descriptions of the present population of railroad passenger cars in the United States.
- Detailed engineering data, as available, on selected major and distinctive passenger car trucks used in the United States. Major and distinctive means trucks that are widely used or may be widely used in the future, and which have a distinctive arrangement of major components and their interconnections.

The discussion of passenger car truck functions and design alternatives begins with a definition of the principal technical terms used to describe trucks and railroad operating conditions. Following this, the primary truck functions are described:

- To support the rail vehicle by providing adequate load paths from the car body to the track for vertical, lateral and longitudinal loads. These load paths react gravitational, acceleration, braking and guidance forces applied to the car.
- To guide the vehicle along the track without incurring wheel to rail forces and force combinations that could lead to a risk of unacceptable track damage or derailment. The requirement usually means avoiding dynamic instability and the generation of excessive forces in curves.
- To isolate the car body from track irregularities, so as to give the car occupants an acceptably comfortable ride, and to maintain vehicle-track loads within acceptable limits.

In addition, a passenger car truck may have to accommodate a variety of auxiliary equipment, such as brakes, electric motors, and gearboxes.

The wide variety of truck designs which have evolved to meet these operating requirements are described, including both the basic four-wheel truck that is used on almost all cars currently operating in the United States, and trucks with added features designed to improve one or more aspects of performance. Different sections of the report describe truck frame arrangements, primary suspension alternatives (between the wheel set and the truck frame), and secondary suspension designs (between the truck frame and the car body). The discussion of trucks and car designs with added features includes bi-level car designs, steering trucks of different types, and single-axle trucks and independent wheel wheel sets.

To provide a structure for the data and descriptions for individual truck designs, a truck design classification scheme was developed. The scheme classified trucks by truck frame type as the primary division, with secondary classification by secondary suspension layout and the presence of additional features.

The primary classifications were as follows:

- Single-axle trucks, for example as fitted to the Spanish Talgo Pendular high-speed tilting train.
- Trucks with independent sideframes, which are commonly used on freight cars and on some baggage cars used in intercity passenger service.

- Articulated frame trucks, such as the Budd Pioneer applied to Amtrak's Amfleet cars used in the Northeast Corridor (at speeds up to 200 km/h (125 mph)), and elsewhere on shorter intercity corridors in the Amtrak system.
- Rigid frame equalizer beam trucks, such as the Buckeye (formerly GSI) G70 series.
- Rigid frame trucks, with the primary suspension positioned between the axle journal and the truck frame, directly above the journal. Trucks of this design are widely used in Europe and Japan, and a number have been supplied to the United States on recently purchased cars.

An analysis of the population of railroad passenger cars in the United States is detailed in Appendix 2. Note that this population only includes cars that operate on the main line railroad system. Cars which only operate on segregated heavy and light rail mass transit systems are not included. The population data show that at the beginning of 1994 there were approximately 6400 passenger cars in operation in the United States. Over 90% of these cars were operated by Amtrak (who operates 26% of the cars), and the six largest commuter rail authorities (Long Island RR, METRA (Chicago), Metro-North, New Jersey Transit, and Boston and Philadelphia's commuter rail systems). Of the 6400 passenger cars, nearly 60% are equipped with different variants and generations of the GSI/Buckeye equalizer-beam cast steel truck. The other leading truck type in the population is the Budd Pioneer at 24% (on Amtrak Amfleet cars and in a powered version on Metro-North and Long Island electric multiple-unit cars). The remaining 16% of the 6400 cars are equipped with rigid frame trucks having the primary suspension directly above the axle journal, the design of which originate in Canada, Europe, Australia, and Japan.

Detailed data on eight selected truck design and passenger car combinations are provided in Appendix 1. The designs were selected to be representative of the trucks currently in use and of trucks likely to be used in increasing numbers in the future. The specific designs included are:

- The Budd Pioneer, as the only truck operated at speeds of 200 km/h (125 mph).
- The GSI/Buckeye G70 inside frame unpowered truck used on most single-level commuter cars.
- The GSI/Buckeye G70 inside frame powered truck, the most commonly used truck on single-level electric multiple-unit commuter cars.
- The GSI/Buckeye G70 outside frame unpowered truck used on recently purchased intercity cars.
- The German Waggon Union MD 76 truck used on the first series of Amtrak Superliner bi-level long-distance intercity cars.
- Three types of unpowered rigid frame journal spring trucks from foreign manufacturers, the Nippon Sharyo and Kawasaki from Japan and the bolsterless Comeng truck from Australia. The Nippon Sharyo trucks are used on single-level commuter cars, and the other two designs on bi-level commuter cars that are increasingly favored by the commuter rail authorities.



# 1. INTRODUCTION

## 1.1 BACKGROUND

In recent years there has been a resurgence of interest in the United States in intercity and commuter railroad passenger services. Several factors have combined to create this interest, including a need to reduce airport and highway congestion in major cities, and to reduce air pollution and other adverse environmental impacts of heavy automobile traffic.

Commuter rail service is an attractive option for improving public transport in medium and large cities. Services can be initiated quickly and at modest cost on existing railroad infrastructure, and can reach the outer suburbs of cities where there are many potential users. As a result, there has been considerable investment in new and expanded commuter rail services. Notable examples of entirely new services are those between Miami and Fort Lauderdale in Florida, several routes in Southern California, and from Washington DC to several points in Northern Virginia. Expansions of existing commuter services are in progress or planned in Boston, San Francisco, Chicago, and elsewhere.

Improved intercity rail services are being proposed as a way to reduce airport congestion and fossil fuel consumption, as well as to provide an attractive service to a segment of the travel market. Amtrak and the federal government are making a major investment in electrifying the Northeast Corridor between New Haven and Boston, and will be acquiring a fleet of 26 high-speed electric trainsets. In addition, federal and state transportation agencies, together with private sector interests, are actively pursuing plans for the development of high-speed rail services in several other intercity corridors. The current (1994) emphasis in these plans is on providing improved service through incremental improvements to existing infrastructure. Plans exist in various stages of development for service improvements between San Francisco and San Diego in California, between Portland, Oregon and Vancouver in the northwest, on several lines centered on Chicago, between Miami, Orlando and Tampa in Florida, and elsewhere. Under Section 1010 of the Intermodal Surface Transportation Efficiency Act of 1991 (ISTEA), incremental infrastructure improvements in selected corridors are eligible for financial support from the federal government.

This interest has led to a substantial and growing investment each year in new rail passenger cars in the United States. Over 6000 rail passenger cars are presently in operation in the United States, and new cars are being delivered at an annual rate of about 200, representing an investment on the order of \$200 million per year. These purchases will likely include cars of new designs, not previously operated in the US, that offer potential benefits in the form of higher speeds, improved comfort, greater passenger capacity, and reduced capital and maintenance costs.

In the past, however, there have been problems with some new car designs when first placed into service in the US. For example, problems can arise when the car encounters operational or track conditions that were not considered in the car design or specification. Where such problems can be detrimental to safety, engineering evaluations must be performed to investigate the causes of the problem. In addition, it is desirable to perform engineering evaluations of new passenger rail car and truck designs, especially those with novel car features such as car body tilt systems and radial or steering trucks. The evaluations are used to determine the safety performance of the car and truck, the benefits of the novel features, to support the car purchaser in developing effective performance specifications, and to compare alternative equipment

options. One class of engineering evaluation is the evaluation of car and truck dynamics, including track-train interaction, ride quality and related issues.

In support of Federal Railroad Administration's (FRA) efforts to improve passenger rail car safety with respect to the dynamics of track-train interaction, the Volpe National Transportation Systems Center (the Volpe Center) is developing analytical tools capable of modelling the various passenger rail car designs currently in service, or which may be considered for service in the United States. The analytical tools will be used to perform analytical studies of the dynamic performance of different car and truck designs for specified track and operational conditions.

The dynamic performance of passenger rail cars is primarily a function of the mass and inertia of car and truck components, and truck or suspension characteristics such as spring stiffnesses and damper rates. Before dynamic analyses can be performed on a particular car design, it is necessary to assemble data on the engineering parameters of the car such as masses, inertias, spring stiffnesses, spring travel, and damping rates. At present, much of the required data are not readily available. The purpose of the study described in this report is to provide, to the extent possible, truck and car engineering data for selected representative car and truck designs. The data can be used to support dynamics analyses, and the accompanying descriptions of truck designs and usage will be useful in helping car operators select appropriate truck or suspension designs for a given application.

## 1.2 PRIOR WORK

Several studies have been carried out in the past to obtain descriptive information and engineering data for different passenger car and truck designs, under the sponsorship of the Volpe Center and the FRA. The most relevant to this study are the following:

- A compilation of engineering data on rapid transit and light rail car trucks, published in 1984 (Reference 1). This study was limited to trucks used on segregated heavy mass transit and light rail systems, and did not address trucks used on commuter or intercity passenger cars. This study is the prototype for the study documented in this report.
- A compilation of data on high-speed passenger trucks published in 1978 (Reference 2). This report provided comprehensive data on high speed truck designs then in service, principally in Europe and Japan. A few of the truck designs covered in this report are currently in service in the US, or are being proposed for service in the future, However, most have been superseded by more recent designs, and the data now has limited applicability.
- A compilation of engineering data on freight and passenger rail cars operating in the United States published in 1981 (Reference 3). The report included data on four passenger car trucks and on two 'generic' passenger car body types.
- A series of reports prepared in the Improved Passenger Equipment Evaluation Program (IPEEP) in the period from 1977 to 1981 (Reference 4). These reports provided descriptions and limited data on intercity passenger train systems existing at that time, but did not provide the level of detail required for dynamics analysis. Also, many of the trains described have now been superseded by more recent designs.
- A report discussing high-speed rail safety issues, accompanied by descriptions and limited data on high-speed train systems, published in 1990 (Reference 5). Like the IPEEP studies, this report provides some general descriptions of the train systems, but the data lacks the detail needed for dynamics analysis.



- A report describing international tilt train systems, published in 1992 (Reference 6). This report is current and provides good qualitative descriptions of the train and tilting truck systems, including some radial or steering trucks, but provides only limited numerical truck parameter data.

It can be seen that these reports are either out-of-date, or fail to provide the detailed numerical data on railroad passenger cars and trucks sufficient to meet the needs of dynamics analysis. Furthermore, the past work has concentrated on foreign high-speed car and truck designs, and has not covered conventional speed intercity and commuter car trucks now being used in increasing numbers. Therefore, there is a strong need for a fresh effort to obtain passenger car and truck descriptions and dynamic data for car designs in use or proposed for use in the United States, to be used in dynamics analysis for safety evaluation and problem-solving.

### **1.3 OBJECTIVES OF THE STUDY**

The overall objective of the study documented in this report is to provide, to the extent practical, detailed engineering data on a representative sample of railroad passenger car trucks and car bodies currently being used, or likely to be used, in the United States. The data are supported by information on the population of railroad car trucks currently in use, and on the operating environment and maintenance experience for the sample trucks. For the purpose of the study, railroad passenger cars are defined as those which operate on the general railroad system of the United States, and are built and operated in compliance with applicable safety regulations of the Federal Railroad Administration and rules, standards and recommended practices of the Association of American Railroads. Truck designs used only on rail vehicles operated on segregated mass transit systems are not included in the study.

In more detail, the specific objectives of the study were:

- Identification of major and distinctive railroad truck designs from domestic US and foreign manufacturers that are in current use, or are proposed for use, on commuter and intercity passenger cars in the United States. In the context of this objective, 'major' means a truck being used or likely to be used in significant numbers in the US, and 'distinctive' means a truck design having unique load-paths between track and car body, or incorporating unique components to perform one or more of the primary functions of a truck.
- Assemble engineering data describing a representative sample of the major and distinctive truck designs in terms of principal masses, inertias, suspension characteristics, dimensions and clearances, and other parameters likely to influence truck dynamic performance. The data include descriptions and illustrations of the layout of each truck design; location of major components and connections between components, and vertical, lateral and longitudinal load paths.
- Assemble engineering data on the car body and truck-car body interface linkages and connections likely to influence dynamic performance for each of the selected major and distinctive truck designs. As with truck data, the data is accompanied by illustrations and descriptions of the layout of mechanical components and the load paths between truck and car body.
- Provide population statistics for railroad passenger car and truck designs in use in the United States, and truck-related maintenance history and typical usage scenarios for the selected major and distinctive truck designs. The usage information includes details of the kinds of rail service in which the trucks are used, maximum speeds, and track conditions likely to be encountered by the trucks and cars on the main line and in yards.

## **1.4 CONTENTS OF THE REPORT**

The principal chapters of the report and the Appendices cover the following subjects:

Chapter 2 provides a detailed discussion of the generic functions of a passenger car truck, and descriptions of the different mechanical truck arrangements that have been developed to perform the functions. The descriptions include both the different arrangements of the widely used basic four-wheel truck, and trucks with added or uncommon features such as single-axle trucks, car body tilt systems or independently rotating wheels.

Chapter 3 introduces a system of classifying railroad passenger car trucks, and provides summary descriptions of trucks currently in use or under consideration for use in the United States (other than trucks specifically developed for high-speed and car body tilt trains), and information on the usage scenarios and maintenance histories of selected truck designs.

Two appendices contain detailed numerical data. Appendix 1 contains detailed truck data for selected major and distinctive truck designs, including all available masses, inertias, suspensions stiffnesses and damping rates, and truck dimensions. Information on usage scenarios and maintenance histories accompany the engineering data for each truck, as well as illustrative drawings and schematics. Appendix 2 contains the details of the population of railroad passenger cars and trucks presently in service or on order in the United States, organized by class of truck and by operator.

## 2. OVERVIEW OF RAIL PASSENGER CAR TRUCK DESIGN

### 2.1 INTRODUCTION

#### 2.1.1 Background

This chapter provides a general discussion of the functions of a rail passenger vehicle suspension system, and describes the different mechanical arrangements that can be used to perform the functions. The basic four-wheel truck design applied to the majority of railroad passenger cars is described separately from alternative designs with added features, such as single-axle and independent-wheel designs. The designs descriptions include general discussions of the constraints and tradeoffs that must be considered by the truck designer in making a selection among alternative mechanical arrangements. Finally, descriptions are provided of different passenger car and train configurations which influence truck design selection and truck performance. These descriptions particularly address articulated train-sets and the differences between single and bi-level cars.

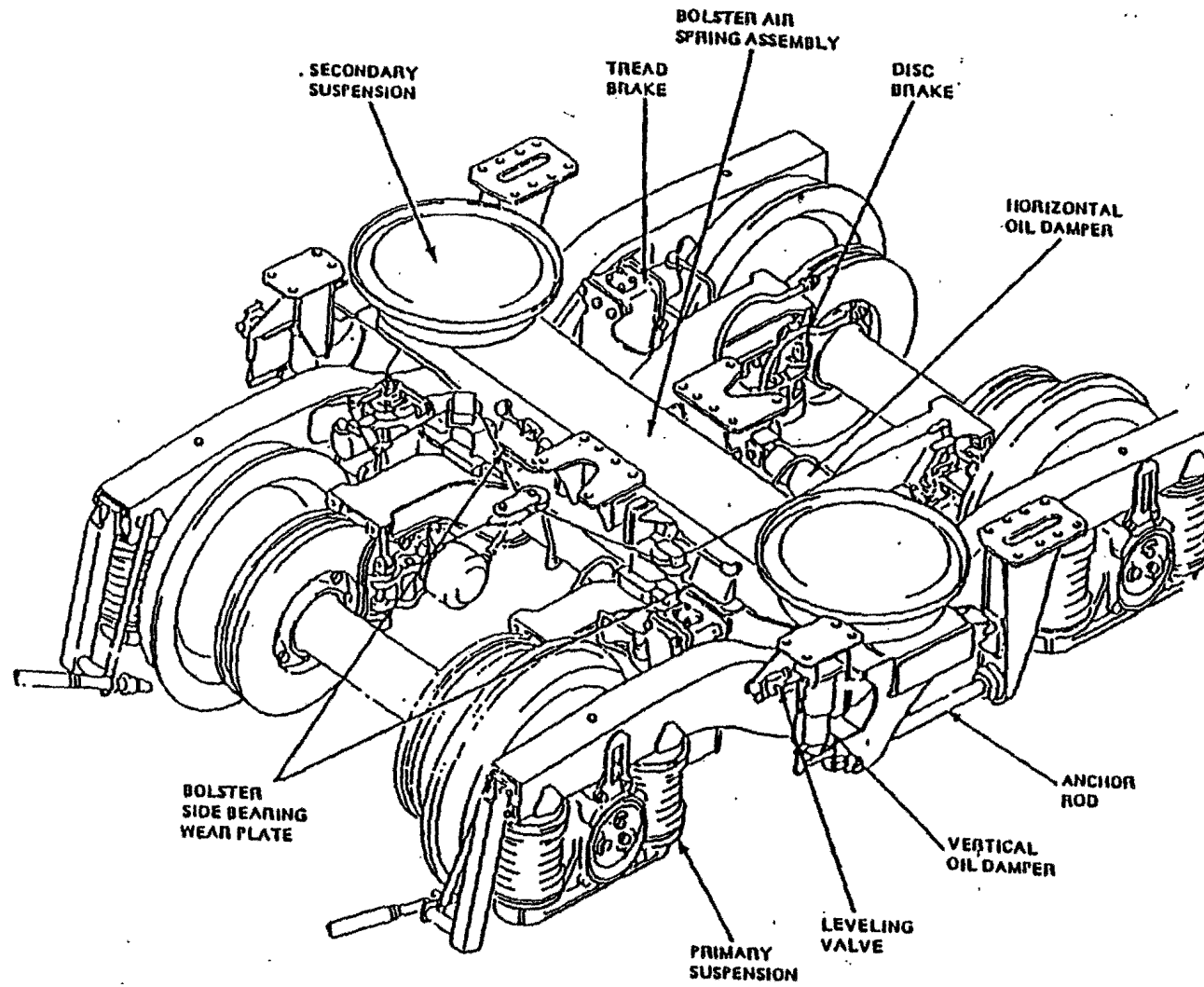
#### 2.1.2 Definitions

In order to better understand the following discussion, it is helpful to define the principal terms used to identify passenger rail vehicle suspension system types and components.

The *Suspension System* is the entire assembly of wheels, springs, dampers, load-bearing structure, and other components which support the vehicle car body, and which perform all the functions described in Section 2.2.

The most commonly used suspension system on passenger rail vehicles is the basic *two-axle truck* (called bogie in European English), with the car body supported by two trucks. A typical truck is illustrated in Figure 2.1. The principal parts of a truck are:

- A *Wheel set*, consisting of two wheels connected by an axle, and axle journal bearings. Usually wheels are solidly attached to the axle, but independently rotating wheels are used in a few designs.
- A *Primary Suspension*, connecting the wheel set to the truck frame, and providing the required stiffness and freedom of movement in all coordinates. In particular, the primary suspension provides sufficient vertical and roll flexibility to reasonably equalize vertical wheel-rail loads, and lateral and yaw stiffness to give the desired dynamic stability and curving performance.
- A *Truck Frame*, providing a structural connection between the primary and secondary suspension. The truck frame may be a one-piece rigid structure, or may incorporate articulation joints or flexible structures.
- A *Brake System*, usually consisting of axle-mounted disk or clasp brakes acting on the wheel tread.



**Figure 2.1 Parts of a Typical Truck  
[Nippon Sharyo NT319]**

**[Source: Manufacturers Information]**

- A *Secondary Suspension*, connecting the truck frame to the car body, and providing the required stiffness and freedom of movement in all coordinates. In particular the secondary suspension provides the soft lateral and vertical springing necessary for a comfortable ride, and a means for the truck to swivel (yaw) relative to the car body.

Commonly used designs for the basic four-wheel truck and its major components are described in Section 2.3 of this chapter.

In addition, there are a number of passenger car truck and trainset designs with additional suspension features. The aim of the additional features is usually to achieve a better compromise between the various conflicting truck design requirements. These designs are usually more complex than the basic designs, and thus are typically used where there is a strong need for higher performance, such as in high-speed intercity trains. The principal truck and vehicle designs having additional features are:

- *Articulated Trains*, in which the suspension system supports the ends of two adjacent vehicles connected by an articulation joint. Articulation is normally used to reduce the overall weight of a train of a given seating capacity, and to increase the ratio of car body to truck mass for improved dynamic performance.
- *Single-Axle Trucks*, in which the suspension system is placed directly between a single wheel set and the car body.
- *Independent Wheel Wheel sets*, where each wheel of the same wheel set rotates independently. Independent wheels are used mainly when a solid axle conflicts with a desired vehicle feature such as a low floor, but also may produce beneficial changes in how the vehicle negotiates curves and achieves dynamic stability.
- *Body Tilt Suspensions*, which incorporate the means for tilting the car body inward in a curve, to improve passenger comfort when curving at high cant deficiency. Tilt systems can either be passive, relying on a pendulum action, or active with tilting provided by a servo-controlled actuator.
- *Radial Trucks*, which have linkages between the axle journals on the axles of the two-axle truck, or between the axle journals and the vehicle body, that either allow or force the axles to assume a more radial attitude in curves. The purpose of radial truck designs is to reduce lateral and longitudinal wheel-rail forces, and thus wear and rolling resistance, without compromising dynamic stability.

Trucks with these additional suspension features are described in Section 2.4.

It is also helpful to define terms used to describe railroad curves and rail vehicle curving, which are important in understanding passenger car truck design features and how they affect performance:

- *Cant* or *Superelevation* is the inward banking of the track applied in curves to counteract the effect of centrifugal force. The usual measure of cant is the height of the outer rail over the inner rail in millimeters or inches.
- *Balance Speed* is that speed on a given curve at which the centrifugal force is exactly balanced by the cant, so that the resultant force is perpendicular to the plane of the rails.
- *Cant Deficiency* or *Unbalance* is the difference between the cant required to produce balance at a given speed on a given curve and the actual track cant.

## 2.2 FUNCTIONS OF A RAIL PASSENGER CAR SUSPENSION

### 2.2.1 Overview

There are three broad functions that a rail passenger car suspension system must perform in order to meet the basic requirements of railroad operation - to permit safe, comfortable and economical operation at the desired speed over track of specified geometrical and strength characteristics. The three broad functions are as follows:

#### 1. Support

- To distribute loads over a sufficient number of wheel sets, to avoid exceeding acceptable static loads on the track.
- To provide paths for transferring support, guidance, propulsion and braking forces from the vehicle body to the track.

#### 2. Guidance and Stability

- To ensure that the vehicle is guided along both tangent and curved track without exceeding acceptable lateral wheel-rail loads.
- To ensure that the truck or suspension system is dynamically stable in all respects, and does not generate unacceptable loads or load combinations as a result of an instability.
- To control the movements of the vehicle relative to fixed structures adjacent to the track, to ensure that clearance limits are not exceeded.

#### 3. Isolation

- To isolate the vehicle body from track irregularities so that ride quality in the body is of a specified quality.
- To ensure that dynamic loads applied to the track in response to track irregularities remain within acceptable limits.

In all the above functions, acceptable wheel-rail or vehicle-track loads means loads and load combinations that do not damage the track, cause excessive wear or deterioration, or pose a risk of derailment.

In addition to the three basic functions, it is frequently necessary or convenient to mount brake, propulsion and other equipment on the suspension system.

The functions and sub-functions are described in more detail in the following sections. The descriptions are derived in part from more detailed discussions of truck performance requirements and performance analysis methods found in the literature. There is a very extensive literature (too vast to be reviewed here) devoted to the mathematical analysis of truck performance (ride quality, curving and stability), to techniques for the experimental measurement of truck performance, and test results for particular truck designs. Of more relevance to the matters discussed in this chapter, however, are discussions of how analytical and testing techniques can be applied to truck design and the selection of truck features for a particular application. References [7] and [8], are particularly helpful. There are also useful sources in the literature which provide data on acceptable performance criteria for different kinds of rail operation, including ride quality, force limits and force ratio limits, for example, [9], [10], [11], and [12].

## **2.2.2 Support**

### **2.2.2.1 Load Distribution**

Rail systems customarily limit the maximum load on one axle allowed to operate over their tracks, to prevent potential damage to track, and to railroad structures such as bridges. The suspension design must distribute the static load from the vehicle over sufficient wheel sets not to violate these limits. Load distribution is most often an issue with power cars, which can have axleloads near acceptable limits.

### **2.2.2.2 Load Paths**

A rail vehicle is ultimately supported and guided by the track structure. The suspension system must provide paths through its structure and load bearing components, such as springs, so that the weight of the vehicle is supported on the track. Vertical, lateral and rotational forces and moments are generated as the vehicle negotiates lateral or vertical curves, and these forces also must be reacted through the track structure. Important specific cases are the lateral and roll forces on the vehicle suspension produced by centrifugal forces when the vehicle travels around a curve at above or below balance speed.

Propulsion and braking forces must be transmitted through appropriate longitudinal suspension connections between the car body and suspension components to the track structure, usually through the wheel-rail contact point. Some more innovative braking and propulsion systems use alternative paths for transmitting braking and propulsion forces, such as directly from magnetic or eddy-current brake coils to the rail, or between the vehicle and track-mounted linear motor components.

## **2.2.3 Guidance and Stability**

### **2.2.3.1 Overview**

Guidance and stability performance must be such that safe wheel to rail force levels and combinations of forces (such as maximum lateral to vertical forces ratios) must not be exceeded. In addition, passenger rail operators may wish to place more restrictive force limits to control the rate of track degradation, and thus maintenance effort.

Commonly used limits are:

- maximum acceptable values of the lateral to vertical ( $L/V$ ) force ratios at individual wheels;
- maximum acceptable ratio of the total of lateral and vertical forces applied by the entire truck to the track structure;
- maximum vertical impact loading at any wheel when passing over a defined track irregularity; and
- minimum value of the vertical load at any wheel.

These limits must be observed under all operating conditions - maximum speed, all conditions of curvature and cant deficiency, and applicable to all track geometry conditions, including low class track in yards and sidings.

Acceptable wheel to rail force levels can be obtained only if adequate dynamic stability, and guidance and curving performance are achieved. These two performance requirements are discussed in more detail below.

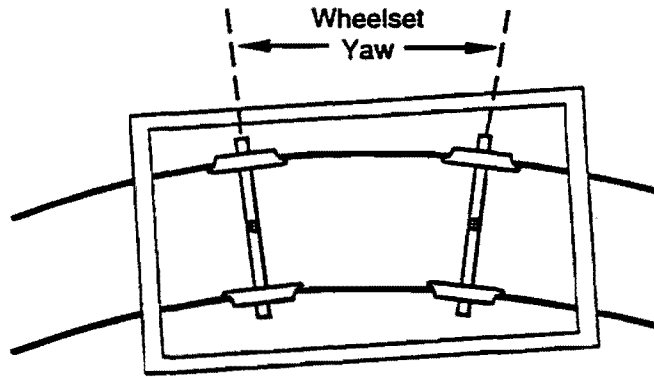
### **2.2.3.2 Guidance**

A vehicle must be able to negotiate all tangent and curved track on the system over which it will operate at all permitted speeds without exceeding acceptable lateral wheel forces or force combinations. Most difficulties in meeting this requirement arise during curving. There are three matters to be considered when a rail passenger vehicle with two two-axle trucks negotiates a curve:

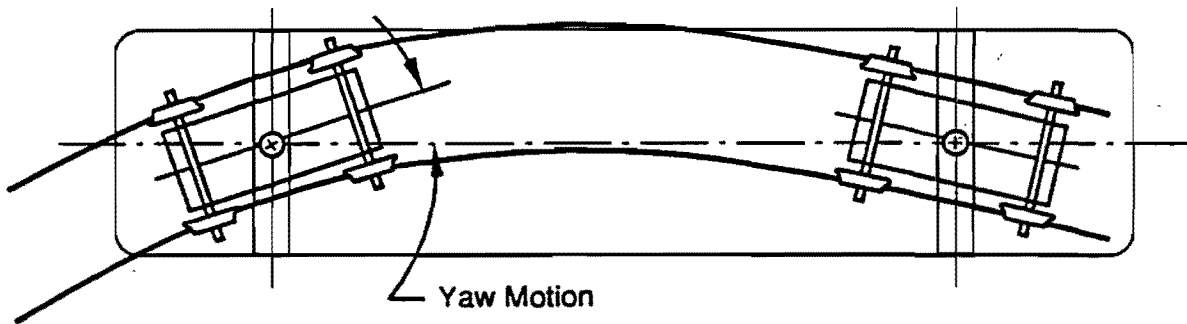
- the need for the wheel sets in each truck to align themselves radially on a curve, and adjust to the greater distance travelled by the outer wheels;
- the transfer of unbalanced centrifugal forces to the track; and
- the yaw of the truck relative to the vehicle body.

While negotiating a curve, wheel sets align themselves approximately radially, with individual axles in the truck yawing relative to the truck frame, as shown in Figure 2.2a. The yaw of wheel sets against the restraint of the primary yaw suspension creates longitudinal and lateral forces at the wheel-rail interface. Lateral forces from unbalanced centrifugal forces, and the yaw torque exerted on the truck frame through the truck to car body yaw restraint (Figure 2.2b) are

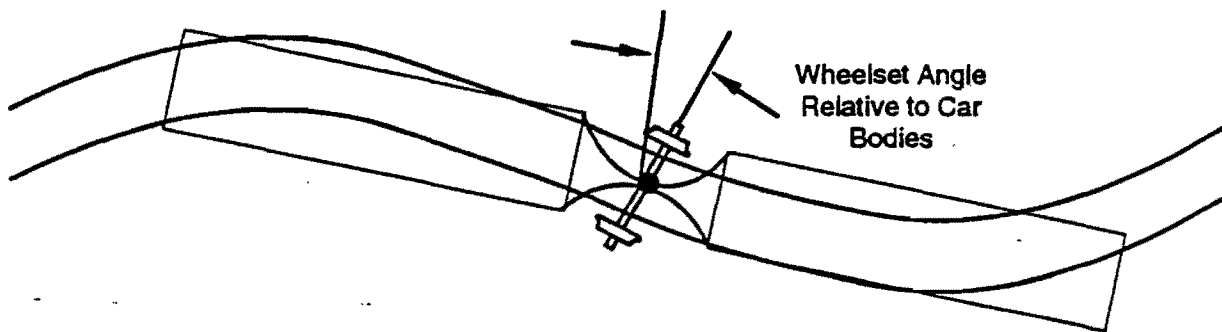




**Figure 2.2a Yaw Motion of Wheelsets in a Curve**



**Figure 2.2b Yaw Motion of Truck Relative to Car Body**



**Figure 2.2c Articulated Single-Axle Train on Reverse Curve**

**Figure 2.2 Conventional Rail Vehicle Curving**

superimposed on the wheel set yaw forces. In response, the truck attains an internal balance where the lateral and longitudinal forces on each wheel set and the truck frame are in equilibrium. Curving performance is satisfactory only when wheel-rail interface forces are within acceptable limits, as described in Section 2.1. Generally, a soft primary yaw suspension reduces curving forces, but tends to degrade stability, as described in Section 2.2.3.3 below.

In order to minimize rail and wheel wear in curves, it is desirable to reduce curving forces to the lowest level possible while still maintaining the necessary stability performance. Given the fundamental limitation on the curving and stability performance of a conventional 4-wheel truck, a number of innovative steering suspension systems have been developed or proposed. Such systems incorporate linkages between the wheel sets and between the truck and car body which permit or force wheels to assume a near-radial position on a curve, reducing curving forces without degrading stability performance. Single-axle trucks and independent wheel suspensions (lacking a rigid axle) also have been used to achieve improved curving performance while maintaining stability. Generally the innovative steering systems are used on high performance passenger cars where the additional cost and complexity can be justified. Particular mechanical arrangements are described later in this chapter.

Finally, a simpler but still important curving requirement is that the truck or suspension design must be able to negotiate a specified tightest curve without mechanical contact between car body and truck structures or components. It is also important to ensure that cables and hoses between the truck and body can accommodate these maximum movements without damage. A minimum curve radius of 73 m (240 ft) is typical of U.S. operating conditions. A minimum radius reverse curve (for example a crossover) may also be specified, and can be a particularly critical design requirement for articulated train designs with single-axle trucks, as illustrated in Figure 2.2c.

### **2.2.3.3 Stability**

A conventional rail vehicle wheel set with a rigid axle and tapered or profiled wheel treads (Figure 2.3a) will automatically tend to center itself on the rails minimizing flange contact on both straight and curved tracks. The effectiveness of this centering action is a function of primary yaw suspension stiffnesses, the mass and inertia of the wheel set and track frame, speed, and other factors. Desirably, the centering action shall be well damped, so that the wheel set or truck returns quickly to a centered position when displaced (Figures 2.3b and 2.3c). However, as speed increases, the centering action usually becomes less damped, and dynamic instability can be encountered. Under unstable conditions, the truck will oscillate laterally and yaw, constrained only by flange/rail contact, and suspension displacement limits (Figure 2.3d). The minimum speed at which instability occurs is known as the critical speed. The instability can be very violent, leading to rapid wear, damage to vehicle and track components, and derailment. Therefore, it follows that rail vehicles must be designed to be stable and well damped at all speeds in the operating range, and with all combinations of wheel tread and rail head geometry likely to be encountered in service, in order to ensure that wheel-rail forces and force ratios remain within acceptable limits.

It is customary to carry out computer analyses of rail vehicle dynamics at the design stage to ensure that stability requirements have been met. Generally, increasing lateral and yaw stiffness between the wheel set and the truck frame, increasing yaw damping between the truck and vehicle body, and reducing the mass and yaw inertia of the wheel set and truck frame relative to the car body tend to increase critical speed.

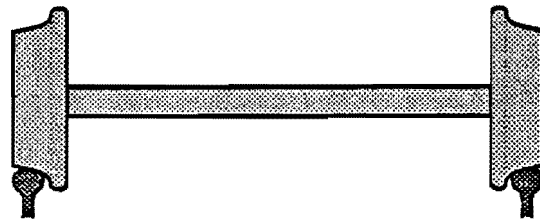


Figure 2.3a Centered Profiled Wheelset

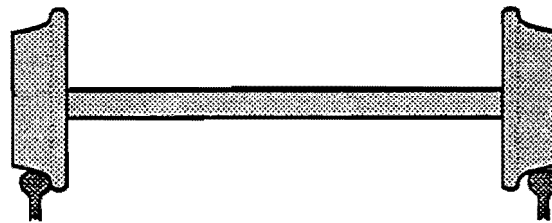


Figure 2.3b Displaced Profiled Wheelset

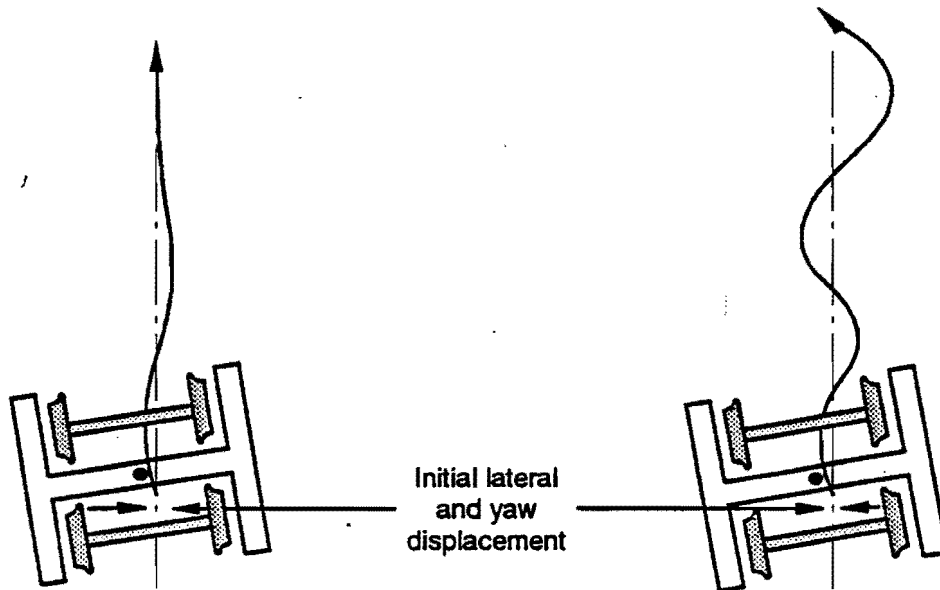


Figure 2.3c Stable Truck Response

Figure 2.3d Unstable Truck Response

Figure 2.3 Dynamic Stability

The requirements for a high critical speed are generally opposite to those for good curving performance (as described in Section 2.2.3.2). Therefore, the truck designer is usually forced to compromise curving performance to achieve stability. Radial or steering truck designs, as described in Section 2.4, use linkages and mechanisms to overcome the performance limits imposed by the stability/curving compromise in the basic two-axle truck design.

Because low wheel set and truck mass and inertia are important in stability performance, it follows that it is most difficult to achieve the necessary stability in powered truck designs that have to carry traction motors or power transmission equipment on the truck frame and axles. In very high speed train designs, complex mechanical arrangements are used to decouple, to the degree possible, the mass of electric traction motors and mechanical transmission components (gearboxes, couplings, drive shafts) from the truck frame and wheel set to achieve a high critical speed.

#### **2.2.3.4 Controlling Vehicle Movements on Suspension**

All rail systems use cross sectional clearance diagrams giving the maximum envelope within which the vehicle cross section must fit at all times, including with maximum deflections of the suspension system in vertical, lateral, yaw roll and pitch within the limits of bump stops. Lateral displacement of the center and ends of the vehicle in curves must also be taken into account in calculating the maximum movements. If any part of the vehicle violates the allowable clearance diagram, there is a risk of it hitting wayside structures such as tunnels, bridges and station platforms, or the power rail in third-rail electrified territory.

A second suspension function on some railroad networks is to maintain floor height adjacent to doors and entryways level with the platform to facilitate passenger loading and unloading. High platforms, at the floor height of a single-level passenger car, are widely used at commuter and intercity rail stations in the Northeast Corridor between Washington and Boston, but are uncommon elsewhere in the U.S. Such platforms allow passage in and out of the car without stepping up or down. Limits may be specified for the maximum difference between floor and platform height under all passenger load conditions. Air spring secondary suspensions with an automatic levelling system are commonly used to meet this requirement.

Use of high platforms and matching of floor and platform heights has become more important with the passage of the Americans with Disabilities Act (ADA), requiring that at least one car in each train is accessible to the disabled. High platforms are one way of meeting the requirements of the Act.

#### **2.2.4 Isolation**

The third major function of a passenger car suspension system is to control the effects of track geometry variations on dynamic loads on the track structure and the ride quality in the car body. These functions are discussed in the following paragraphs, together with wheel-rail load equalization. Equalization is concerned with keeping the quasi-static vertical load variations within acceptable limits as a car negotiates twisted or warped track.

#### **2.2.4.1 Dynamic Track Loads**

Dynamic vertical and lateral loads on the track result from the response of the passenger car to track geometry variations. The magnitudes of dynamic loads depend on suspension stiffnesses and car and truck component masses. Unsprung mass, usually the mass of the wheel set and its attachments, primary vertical stiffness, and the mass of the truck frame are among the important factors affecting dynamic loading. Generally the higher the masses and stiffnesses, the higher the dynamic loads. Loads also generally increase with speed, and are affected by harmonic resonance between periodic geometry inputs and suspension natural frequencies. Dynamic load limits are usually specified by passenger car purchasers, and cars are tested to demonstrate compliance. The load limits are those loads and load combinations known to be safe, and to not cause excessive degradation of the track. Control of dynamic loads is also a reason why higher class track with tighter geometrical tolerances is required for higher speed operation.

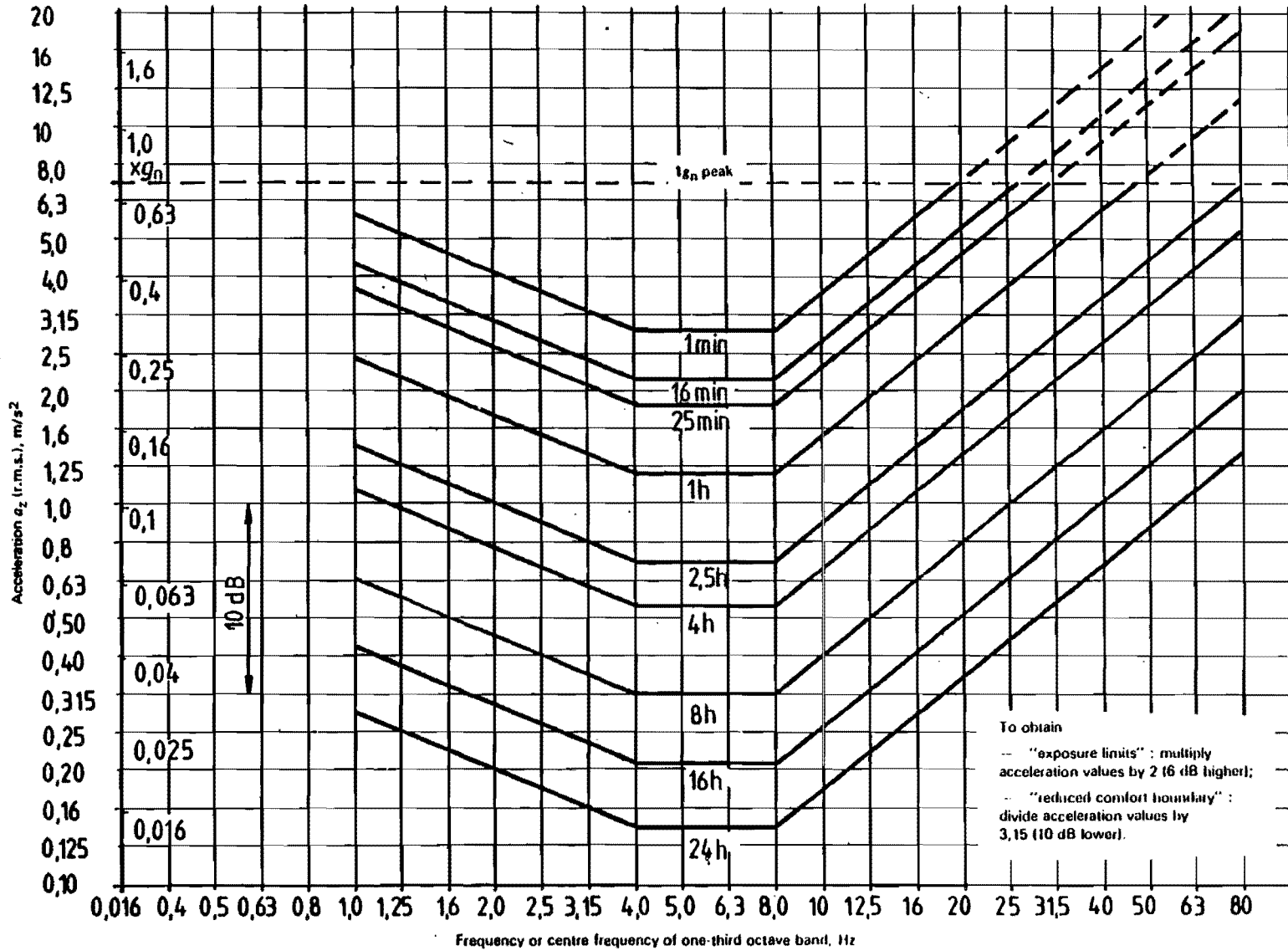
#### **2.2.4.2 Equalization**

Equalization is the ability of the rail vehicle to maintain vertical wheel load variations within acceptable limits on all wheels while negotiating warped or twisted track. Acceptable equalization performance, defined as not reducing load on any one wheel below a specified minimum, must be achieved between the wheel sets of a truck and between the trucks (of any design) applied to a single vehicle or an articulated trainset. The minimum load is that which in combination with estimated lateral load and wheel-rail contact conditions has an acceptably low risk of derailment or damaging the track. A demanding condition is passage through a sharp curve (where lateral wheel-rail forces are high), on low-quality track with large warp geometry variations.

Because twist or warp track irregularities tend to be of relatively short wavelength (less than one rail length) and vehicle secondary vertical and roll suspensions are soft, equalization between trucks is rarely a problem. Truck primary vertical suspensions, however, can be relatively stiff, and the major truck design concern is to achieve satisfactory wheel load equalization between the wheel sets of the basic two-axle truck. A variety of truck arrangements are used to achieve satisfactory equalization, including articulated truck frames, equalizer beams to reduce truck primary pitch stiffness, and soft primary vertical suspensions. These arrangements are described in Section 2.3.2.

#### **2.2.4.2 Isolation of the Vehicle Body from Track Irregularities**

A passenger-carrying rail vehicle is expected to provide a defined ride quality in the passenger seating areas. The ride quality required depends on the kind of rail service: a higher quality is required of a car used in long-distance intercity service than one used for short commuter trips. Ride quality can be specified in a number of ways, typically including acceptable mean or peak accelerations over the frequency ranges of interest. The variation in human sensitivity to vibration at different frequencies is reflected in the specified vibration levels or vibration weighting function. Figure 2.4 is taken from the widely used ISO ride quality standard ISO 2631/1 (1985)[Reference 11]. Ride quality targets should be attained through the operating speed range of the vehicle and over the prevailing track quality on the lines over which the vehicle will be operated.



**Figure 2.4 Ride Quality Standards: ISO 2631 Reduced Proficiency Boundaries for Vertical Accelerations on Standing or Seated Person**

[Source: Reference 11]

Achieving acceptable ride quality on a passenger vehicle usually requires soft vertical and lateral secondary suspensions, with rigid body natural frequencies ranging from 1.5 Hz down to below 1 Hz, plus suitable damping. Since a directly connected damper in parallel with the secondary spring degrades suspension performance at higher input frequencies (exceeding twice the natural frequency), it is very desirable to place a spring in series with the damper to prevent undesirable high frequency vibration transmission to the body. Such a spring, usually in the form of a rubber bush, also serves to reduce noise transmission through the suspension system.

Another ride quality requirement is to maintain steady state lateral and longitudinal accelerations within acceptable limits, together with rates of change of lateral and longitudinal acceleration (sometimes called jerk). Typical maximum values of steady state lateral or longitudinal acceleration for rail vehicles are of the order of 0.1 g, the most that can be conveniently sustained by standing and walking passengers [Reference 10]. This requirement particularly places limits on the maximum cant deficiency (deficiency of superelevation) that is permissible when negotiating a curve. The combined effects of centrifugal acceleration and the outward lean of a vehicle on its suspension mean that maximum allowable cant deficiency is in the range 100 to 150 mm (4-6 inches). The ride quality limit on curving speed is typically encountered before the wheel-rail force safety limits. Thus, active or passive pendular body tilt systems have been developed to maintain ride quality while allowing higher curving speeds. Tilt systems have been described in detail in Reference [6].

In general, ride quality requirements which typically limit the maximum stiffness of the secondary suspension, conflict with the requirement to limit vehicle movement on its suspension to avoid violating clearances. Bump-stops to limit suspension movement in each direction (lateral, vertical) are required, and frequent bump-stop contact degrades ride quality. One way of improving ride quality is to restrict the cross-sectional size of the vehicle, thus permitting a suspension system to be softer, with greater suspension travel to bump-stops.

Active suspension systems can be used to improve ride quality without accepting larger vehicle movement on its suspension. In an active suspension, a servo-controlled system replaces or supplements passive suspension components such as springs and dampers. An active system can be capable of improving on the ride quality provided by passive suspension components within a given permitted maximum suspension travel.

To date, use of active suspension systems in rail vehicles has been restricted to active tilt systems, to enable vehicles to negotiate a curve at high cant deficiency without exceeding permissible steady-state lateral acceleration criteria in the car body. However, active suspensions are beginning to be used in highway vehicles, and the technology may be applicable to passenger rail vehicles to improve ride quality on lower quality track, thus reducing the overall cost of providing service.

### **2.2.5 Suspension Mounted Equipment**

Almost all passenger rail vehicle trucks or suspension systems have to accommodate a brake system, and a traction motor and/or gearbox on powered axles. It is also a common requirement to attach other equipment to the trucks or suspension systems such as a third-rail contact shoe for power collection, a grounding brush (to provide a return path from the vehicle to the wheel and track for electric power, and to ensure that the vehicle is properly grounded), and antennae or

pick-ups for signal and train control commands. Brakes, traction systems, and other equipment are described in the following paragraphs.

### **2.2.5.1 Brakes**

Most types of passenger car brake systems apply a braking torque to the wheel set, producing a longitudinal braking force at the wheel-rail interface. The braking torque can be produced by a single brake shoe acting on the wheel tread (Figure 2.5a), a clasp-type brake having two shoes acting on each wheel (Figure 2.5b), or a disk brake mounted on the axle (Figure 2.5c). An alternative form of the disk brake has the discs mounted on the web of the wheel. Usually two disks per axle are used, but high speed trains, operating at over 200 km/h (124 mph), may need 3 or 4 disks on an axle. Brakes are usually operated by a pneumatic actuator mounted on the truck or car body

The impact of braking systems on suspension system design is three fold.

- Space has to be found within the suspension or truck design for the brake mechanism.
- The brake actuators and linkages are normally, at least in part, on the truck frame or wheel set.
- Braking induced forces or torques in suspension components such as springs should be tolerable, and in particular should still leave adequate suspension travel for proper operation. Braking arrangements that produce excessive suspension forces, or which have the effect of creating an undesired alternative load path for suspension forces, must be avoided.

In high-speed trains, and also on some types of transit car, brakes acting on the wheel or wheel-set may be supplemented by brakes that act directly on the rail. Two types of brake are used - eddy current brakes in which electrical windings have to be positioned just above the rail, and magnetic track brakes which clamp onto the rail when energized. In both cases, the brake unit must be supported on the truck frame or an equivalent part of the suspension structure just above the rail, as shown in Figure 2.5d.

On electrically driven passenger and power cars, braking can be provided by operating the electric motors as generators. The energy can be dissipated in resistor banks (dynamic braking) or returned to the power supply system on an electrified railroad (regenerative braking).

### **2.2.5.2 Traction Equipment**

All powered rail vehicles presently in service are driven through the wheels. A wide variety of mechanical arrangements are used, depending on power levels, operating speeds, and other factors. The overall objective of the designer of a powered truck or suspension system is to have the simplest traction system possible, while observing limits on wheel set and truck frame mass and inertia that derive from stability and isolation requirements.

The majority of rail passenger car and locomotive power trucks are electrically powered, with the motor armature shaft parallel to and adjacent to the axle, driving the wheel set through a



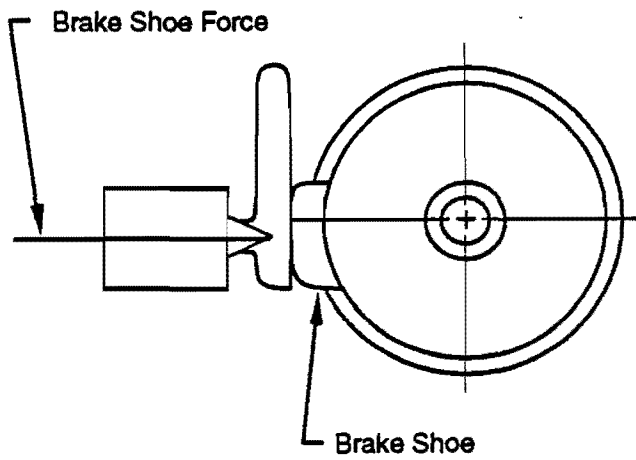


Figure 2.5a Single Shoe Tread Brake

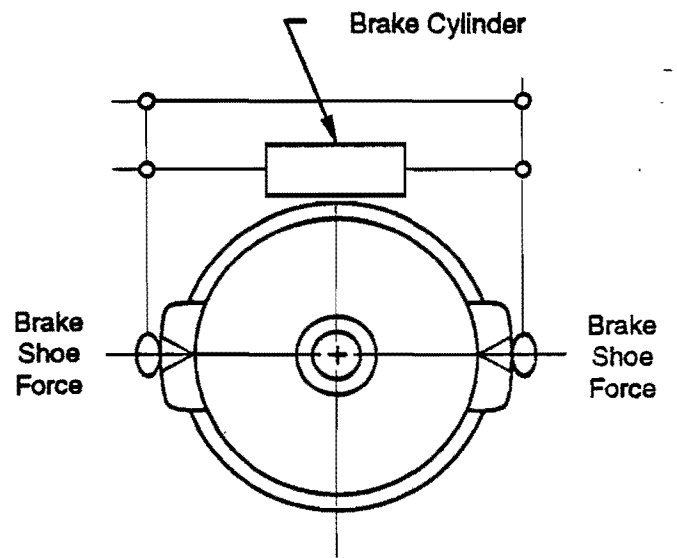


Figure 2.5b Clasp Tread Brake

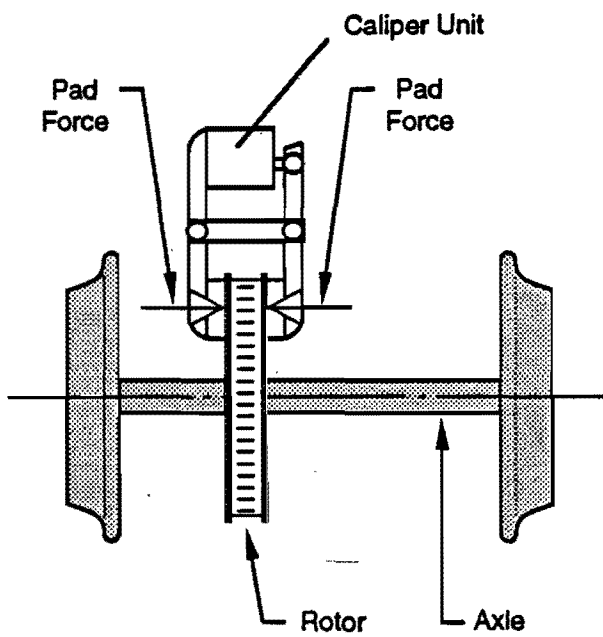


Figure 2.5c Disk Brake

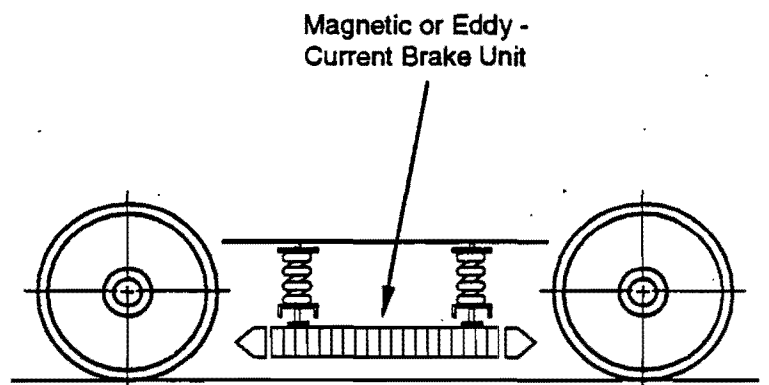


Figure 2.5d Track Brake

Figure 2.5 Alternative Brake Arrangements

gearbox (Figure 2.6a). The motor and gearbox can be supported in several ways, depending on the motor weight and the speed of operation.

- *Axle-hung motor*, with the motor/gear box assembly is partially supported on the axle and partly on the truck frame (Figure 2.6b). This arrangement is very simple, needing no flexible couplings, but part of the motor mass is added to the wheel set vertically and all the motor mass is coupled to the wheel set in lateral and yaw, increasing effective wheel set mass and yaw inertia. This arrangement is unsuitable for high speed, but is widely used for slower speed operations such as on diesel-electric freight locomotives.
- *Truck frame supported motor* with flexible coupling between motor and gearbox or gearbox and axle (Figure 2.6c). In this arrangement, all of the motor mass is supported on the truck frame, and only part or all of the gearbox and coupling assembly is supported on the axle. This arrangement is widely used on multiple unit (mu) trains and power cars designed for speeds between 125 and 200 km/h (79-125 mph).
- *Car body mounted motors*, with the motor in the same location as with a truck-frame mounted motor but with motor mass largely supported on the car body. The flexible couplings have to be able to accommodate large car body to truck movements. This complex and costly arrangement is used only on the power cars of very high-speed trains, designed for 250 km/h (155 mph) and above, such as the German ICE train.
- *Direct drive from the vehicle body* using a longitudinal drive shaft and a truck frame or axle mounted right-angle gearbox (Figure 2.7). This arrangement is used in diesel- or turbine-mechanical direct-drive rail cars, and with body-mounted electric motors, most notably in the Italian Pendolino tilt train. The diesel engines, turbines, or electric motors are typically mounted under the floor of the car body, inboard of the trucks. The only drives of this type currently used in the United States are on the Rohr and ANF French-design turbo-trains, currently providing Amtrak service between New York and Albany, NY.

### 2.2.5.3 Miscellaneous Equipment

In general, there are rarely significant difficulties in accommodating the miscellaneous equipment on the suspension, provided the designer takes requirements into account at an early stage in the design. Typical types of equipment that may be installed on a truck include the following:

- Grounding brush to provide an electrical connection between the axle and the vehicle. The grounding brush is typically mounted in the axle journal-bearing cover, and bears on the end of the axle.
- A speed sensor for braking and other train control functions. The speed sensor is also typically mounted on the axle journal bearing, but in the future may be supplemented by doppler radar-based systems.
- Antennae or pick-ups for track-to-train communication systems. These units are sometimes required to be mounted on a truck frame so as to maintain the desired spacial relationship with track-mounted or wayside equipment.

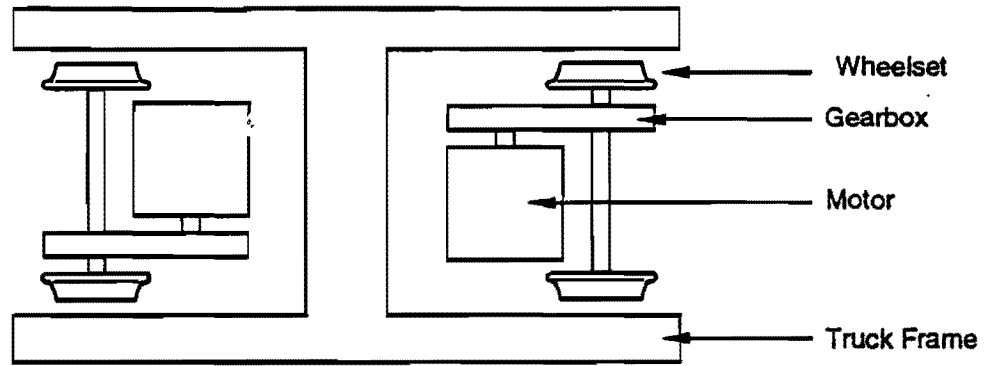


Figure 2.6a Parallel-axis Motor Position in Truck

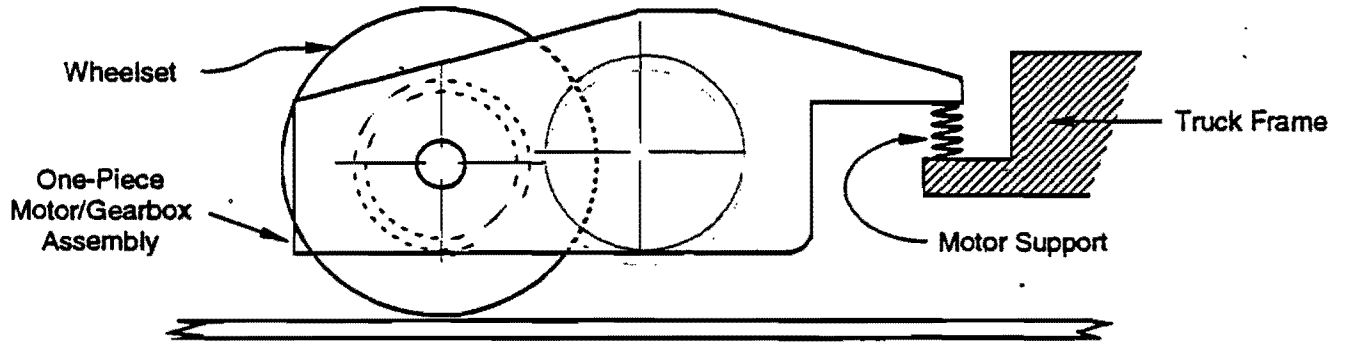


Figure 2.6b Axle-Hung Motor Support

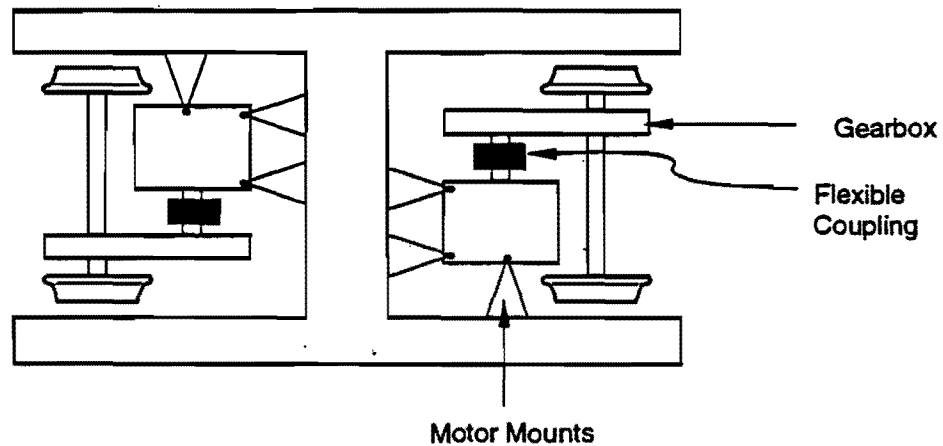
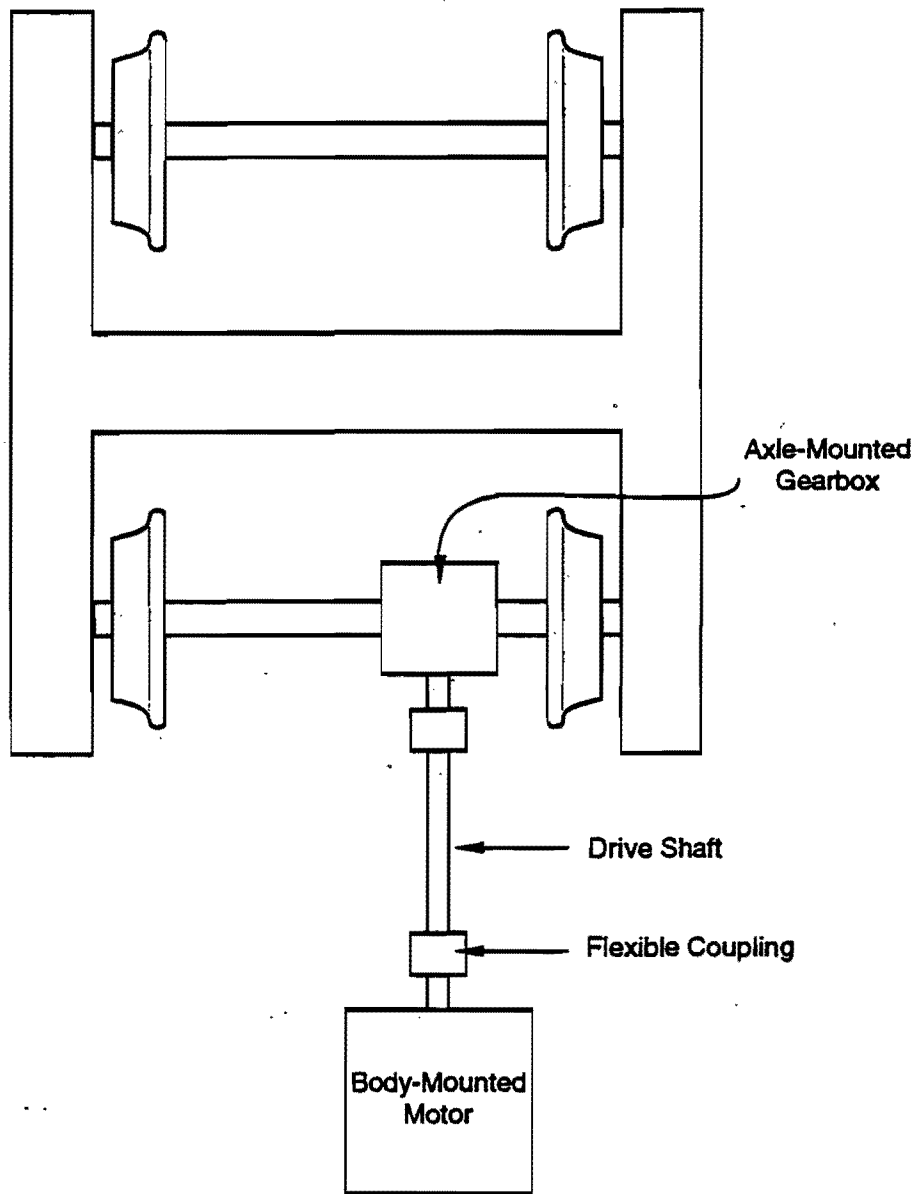


Figure 2.6c Truck-Frame-Supported Motor (representative)

Figure 2.6 Traction Motor Arrangements



**Figure 2.7 Transmission Shaft Drive Through Right-Angle Gearbox**

- Third-rail pick-up shoe. The allowable movements of the pick-up shoe relative to the third rail are usually very limited. Therefore, the pick-up shoes need to be mounted directly on an unsprung component of the truck. Usual practice is to mount the shoes on a beam of insulating material attached at each end to the journal boxes.

## **2.3 CONVENTIONAL 2-AXLE TRUCK DESIGNS**

### **2.3.1 Introduction**

This section describes the major designs of basic two-axle powered or unpowered trucks, applied to all single or bi-level passenger cars presently operating in the United States. Truck and suspension designs having alternative or specialized features (tilting, steering, articulated trainsets, and single-axle and independent wheel systems) are described in Section 2.4, concentrating on differences from the basic two-axle truck. Separate descriptions are provided for truck primary and secondary suspension arrangements.

The primary suspension is situated between the wheel set and the truck frame. The primary suspension strongly influences wheel-rail forces (stability, curving, equalization), and provides a path between the truck frame and the wheel set for support, guidance, traction and braking forces.

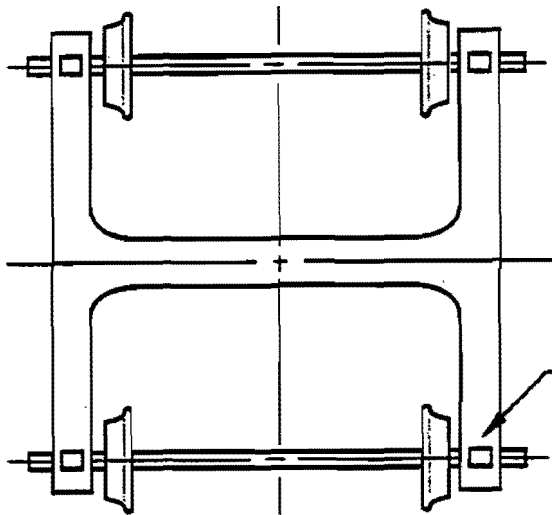
The secondary suspension is situated between the truck frame and the car body. The secondary suspension strongly influences the ride quality in the car body and the vehicle movements on the suspension relative to wayside structures. It also provides a path between the car body and the truck frame for support, guidance, braking and traction forces.

### **2.3.2 Primary Suspension Configurations**

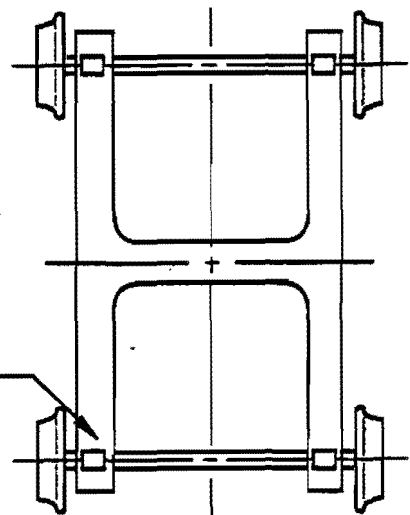
There are three basic primary suspension configurations:

- articulated frame;
- rigid frame equalizer beam; and
- rigid frame journal spring.

All three primary suspension configurations can be applied to trucks having either inboard or outboard axle journal bearings. The axle journal bearings which connect the axle to the truck frame are outboard bearings if they are situated outside the wheels, as illustrated in Figure 2.8a, and inboard bearings if they are between the wheels, as illustrated in Figure 2.8b. Thus, the truck frame of an outboard bearing truck will typically have a longitudinal structural member situated above the bearings outboard of the wheels, whereas in an inboard bearing truck, this member is situated between the wheels. Inboard journals result in a lighter truck frame (because of a shorter transverse truck frame member), a lower primary roll stiffness and better equalization performance, but provide less space within the frame to accommodate brake and traction motor equipment. Outboard journal trucks are heavier because of the longer center cross-member (usually called a transom), but are stiffer in roll and provide more space for brake and traction motor equipment.



**Figure 2.8a Outboard Bearing Truck**



**Figure 2.8b Inboard Bearing Truck**

Bearing Location

**Figure 2.8 Journal – Bearing Arrangements**

### **2.3.2.1 Flexible or Articulated Frame Truck**

The principal characteristic of the articulated frame truck is the ability of one sideframe to pitch relative to the other with a comparatively low relative pitching (twisting) stiffness. Flexible articulated frame trucks meet equalization design requirements using this side frame relative pitching capability. The only type of flexible or articulated frame truck is currently used in railroad operation in the United States is that having a central articulation pivot (Figure 2.9a).

Other types used in transit applications or elsewhere in the world are:

- Independent sideframes with two diagonally-opposite ball-joints in the transverse transom (Figure 2.9b).
- One-piece truck frames with a flexible transverse member (transom), to accommodate relative pitch of the sideframes (Figure 2.9c). The transom must be sufficiently stiff in longitudinal shear and bending to prevent undesirable "parallelogramming" of the truck frame, and, at the same time, allow relative pitch of the sideframes.

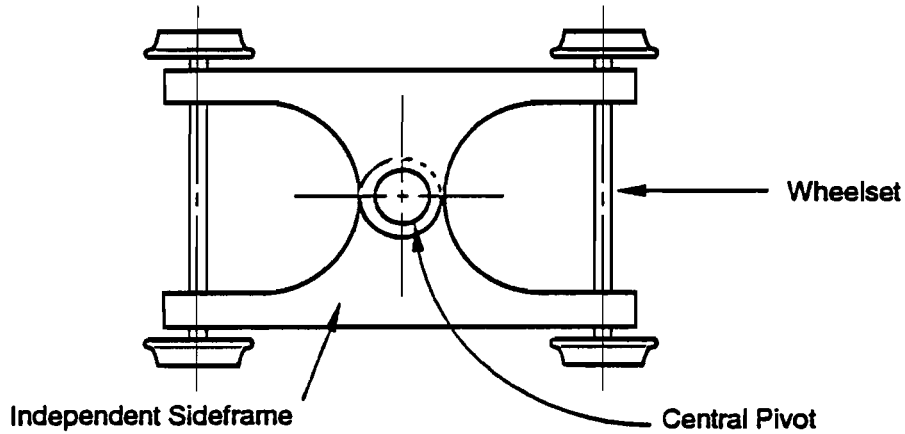
Since equalization is provided by frame flexing or articulation, this truck type does not need soft suspension between the truck frame and journal box. Usual practice is to enclose the bearing in a rubber bush providing a relatively stiff wheel set-to-frame yaw and lateral suspension for stability.

The advantage of the articulated truck frame is that equalization is very good, and the complication of four-axle journal vertical suspension units is avoided. The disadvantages are that the truck frame is nearly completely unsprung vertically, leading to relatively high vertical dynamic loads on the track, and that the articulation pivot can be complex and subject to wear.

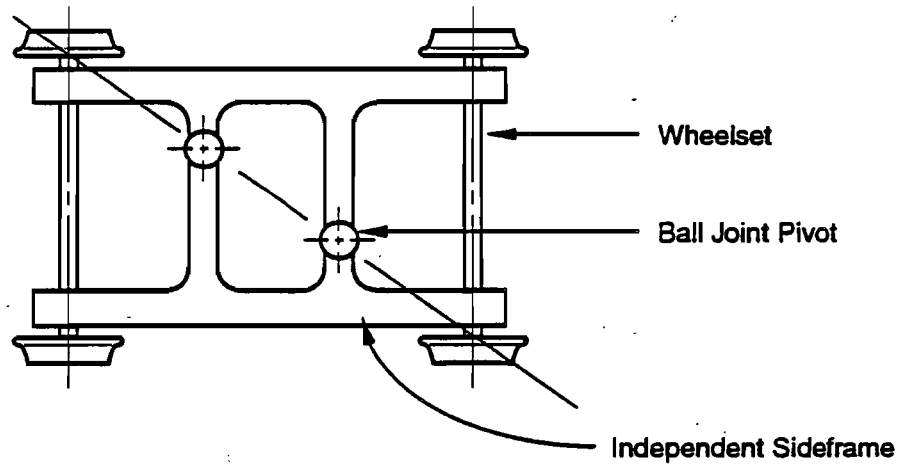
### **2.3.2.2 Equalizer Beam Truck**

In the equalizer-beam truck, the journal boxes are free to move vertically in pedestal guides on the truck frame. The ends of the equalizer beam rest on the journal boxes, and the truck frame is supported on the equalizer beam on springs situated inboard of the journal boxes (Figure 2.10). The relative roll stiffness between the axles of the truck, and thus equalization performance, is a function of the longitudinal and lateral primary spring spacing. As spacing reduces, relative roll stiffness between axles reduces and better wheel load equalization on twisted track is achieved. The lateral spacing of primary vertical springs depends directly on whether inboard and outboard journal bearings are used, as described in the introduction to Section 2.3.2.

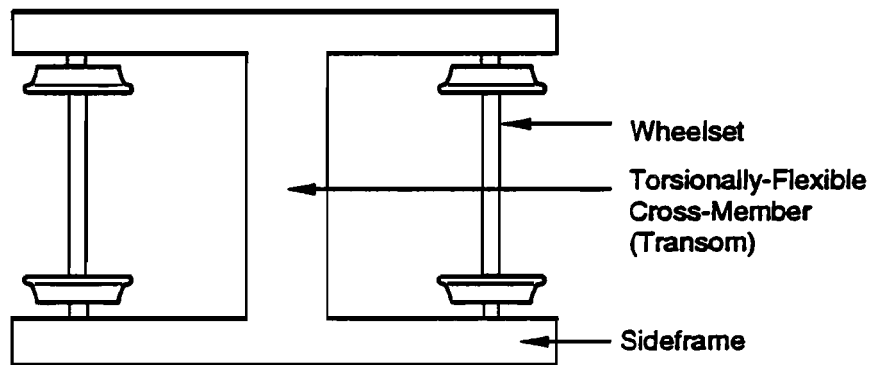
The advantages of equalizer beam trucks are that good equalization can be achieved even with a relatively stiff vertical primary suspension. The disadvantages are that the equalizer beam adds unsprung mass, and the pedestal guides normally used with the equalizer beam arrangement have sliding, wearing surfaces, and do not provide the closely controlled primary longitudinal and lateral stiffness desirable in a high-speed truck.



**Figure 2.9a Central Pivot (Budd Pioneer)**



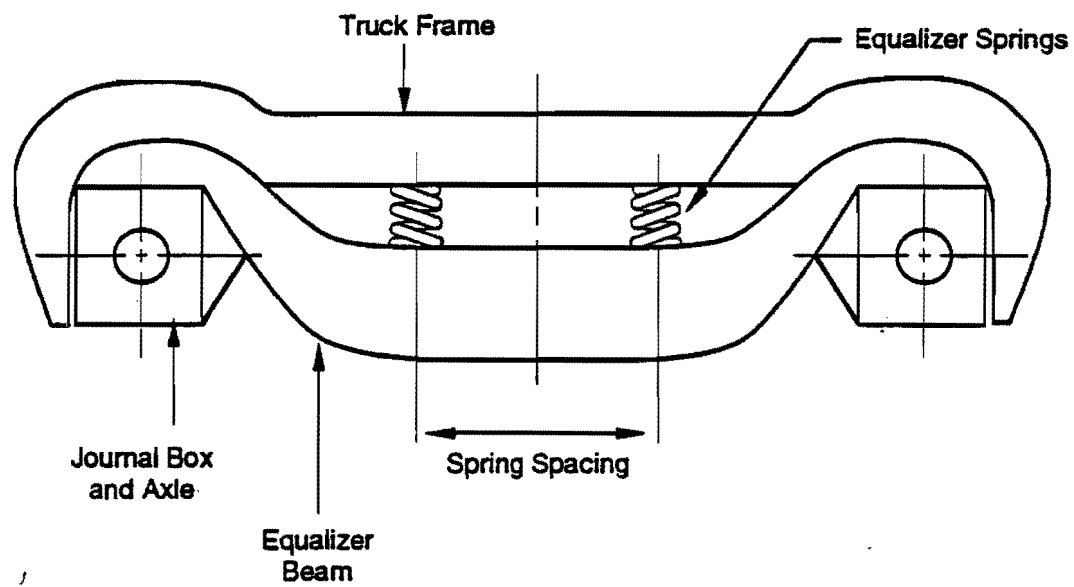
**Figure 2.9b Pivots in Transoms (Rockwell)**



**Figure 2.9c Torsionally-Flexible Frame**

**Figure 2.9 Flexible or Articulated Truck Frames**





**Figure 2.10 Equalizer Beam Primary Suspension**

### 2.3.2.3 Rigid Frame Journal Spring Trucks

In the rigid frame, journal spring truck design, vertical, lateral and longitudinal springs directly connect the journal box to the truck frame. This arrangement is the most common in current international truck design practice, and a large number of variants exist. Journal spring trucks have not been widely used in the U.S., principally because passenger cars have been operated over track with relatively poor geometry, on which good wheel-load equalization is important. With otherwise similar features, the equalization performance of journal spring trucks is inferior to the equalizer beam and articulated frame trucks. Another factor is the North American practice of using staggered joints in bolted-joint rail, which can produce large twist track geometry variations. Parallel rail joints used in Europe and Japan do not produce such twist variations, lessening the importance of equalization in truck design.

In all journal spring truck variants, equalization is provided by the primary vertical springs situated above or alongside the journal box. Thus, the journal spring truck has to have correspondingly softer vertical springs than the equalizer beam truck to achieve the same equalization performance. The advantages of the journal spring arrangements are that it provides a low unsprung mass, and good control of all primary suspension parameters is possible. The variants most commonly used are:

- **Coil Spring and Pedestal (Figure 2.11a).** In this arrangement, the journal box is constrained to move vertically in pedestal guides attached to the truck frame. The spring is situated between the journal box and the truck frame. This design has the same disadvantages as the pedestal guide used in the equalizer beam design, in that it has sliding, wearing surfaces and primary lateral and longitudinal stiffness cannot be closely controlled. A vertical hydraulic damper can be used alongside the spring, and some damping is provided in any case by the friction between the pedestal guide and the journal box.
- **Rubber Chevron (Figure 2.11b).** In this arrangement, vertical, longitudinal and lateral journal box to frame suspension is provided by a rubber/steel sandwich spring. Stiffness variation in the three coordinates is obtained by adjusting the angles of the spring elements relative to the main truck axes, and the number and dimensions of rubber blocks between the steel leaves. The rubber chevron design provides closely controlled stiffness in all three axes, but because of the relatively low strength of rubber, they tend to be bulky in comparison to designs using steel springs, especially if a low vertical stiffness is desired for good equalization.
- **Rolling Rubber Ring (Figure 2.11c).** This is another rubber spring design, in which a rolling rubber ring is trapped between tapered cylindrical guidepost and pedestal elements. The vertical stiffness is provided by progressive squeezing of the ring as the suspension is compressed. Usually two units are used, situated at either side of the journal box. Lateral and longitudinal primary stiffnesses are a function of the thickness and diameter of the rubber ring, and cannot be varied independently. Like the chevron spring, the rolling ring spring tends to be bulky in comparison with steel spring designs.

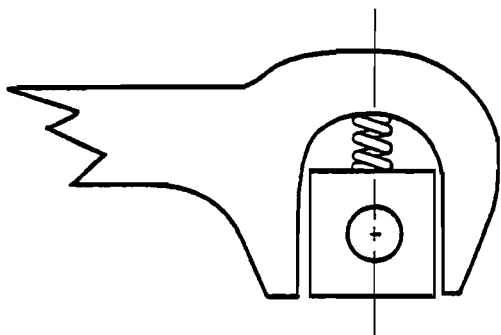


Figure 2.11a Coil Spring/Pedestal

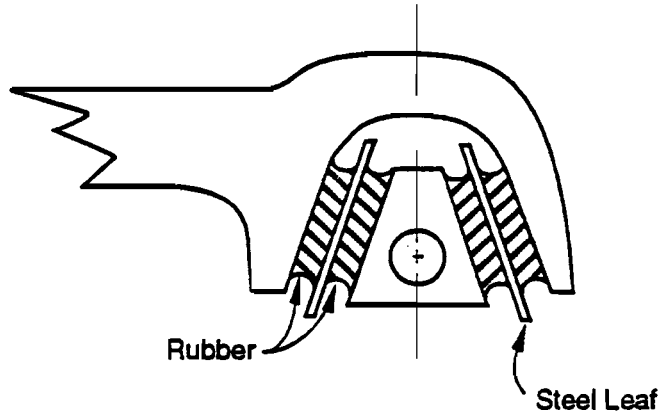


Figure 2.11b Rubber Chevron

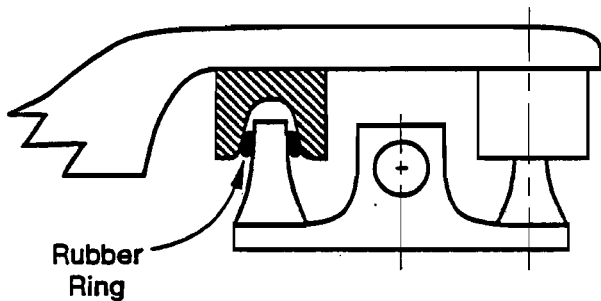


Figure 2.11c Rolling Rubber Ring

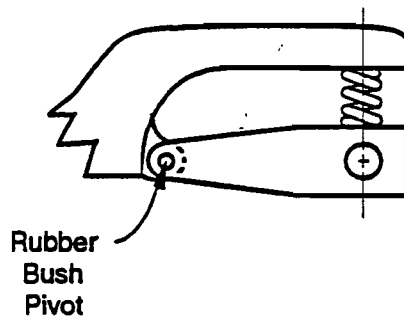


Figure 2.11d Radius Arm

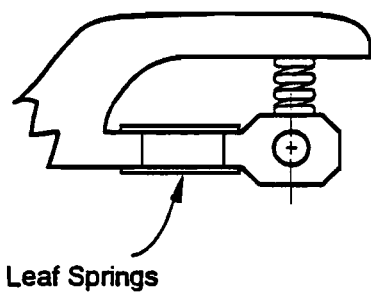


Figure 2.11e Leaf Spring Guides

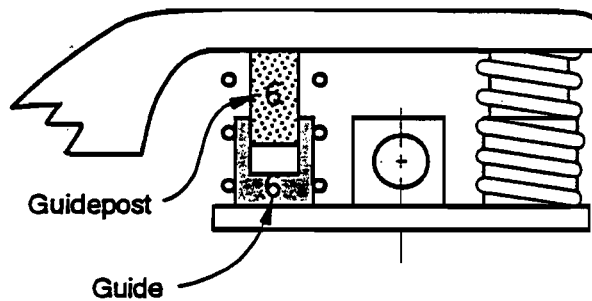


Figure 2.11f Guidepost

Figure 2.11 Primary Suspension and Journal Bearing Arrangements

- **Radius Arm Suspension (Figure 2.11d).** In this arrangement, the journal bearing is situated at the end of a radius arm pivoted to the truck frame and the spring (usually a coil spring, although a rubber spring can also be used) is situated above the journal box, between the journal box and the truck frame. Longitudinal and lateral stiffness is controlled by a rubber bush at the trailing arm pivot. This arrangement is widely used in Europe, including for high-speed trains such as the TGV, but has been little used in the U.S. Relatively high longitudinal and yaw primary stiffnesses are a usual characteristic, providing good high-speed stability but reduced curving performance.
- **Leaf Spring Guides (Figure 2.11e).** In this arrangement, the journal box is located by a pair of leaf springs attached to the journal box at one end, and to the truck frame at the other end. The primary vertical spring (usually steel coil), is situated above the journal box, or a pair of springs are situated either side of the journal box. Leaf spring suspensions are sometimes called Minden-Deutz or MD suspensions, because of the origin of this design in the Minden Technical Center of German Federal Railways (DB).

The longitudinal and lateral suspension is provided by rubber blocks at the ends of the leaves. However, it is difficult to provide much flexibility in this way, and leaf spring suspensions are typically very stiff laterally and longitudinally.

- **Guidepost Suspension (Figure 2.11f).** In this arrangement, the journal box is equipped with a pair of hollow guides, which slide on vertical guideposts mounted in the truck frame. The hollow guides can incorporate rubber bushes which provide primary lateral and longitudinal suspension, and vertical springing is provided by a coil spring outside the guidepost. The guides can be oil lubricated, or a dry bearing material can be used. This arrangement is popular in Switzerland, where the design originated.

### **2.3.3 Secondary Suspension Configurations**

There are four broad secondary suspension configurations commonly used on 2-axle trucks, distinguished by the truck pivot location and arrangement, the degrees of freedom of the secondary vertical springs, and the type of secondary vertical spring used. The principal different configurations are:

- Traditional swing hanger, center pivot truck with single-function (vertical only) secondary springs, as illustrated in Figure 2.12a;
- Upper yaw pivot arrangement, with dual function (lateral/vertical) secondary springs, as illustrated in Figure 2.12b;
- Lower yaw pivot arrangement, with dual function (lateral/vertical) secondary springs, as illustrated in Figure 2.13a; and
- Pivotless, bolsterless arrangement with triple function (lateral, vertical, yaw) secondary springs, as illustrated in Figure 2.13b.

Different types of secondary springs (coil or air springs) and dampers can be used in any of the four configurations.

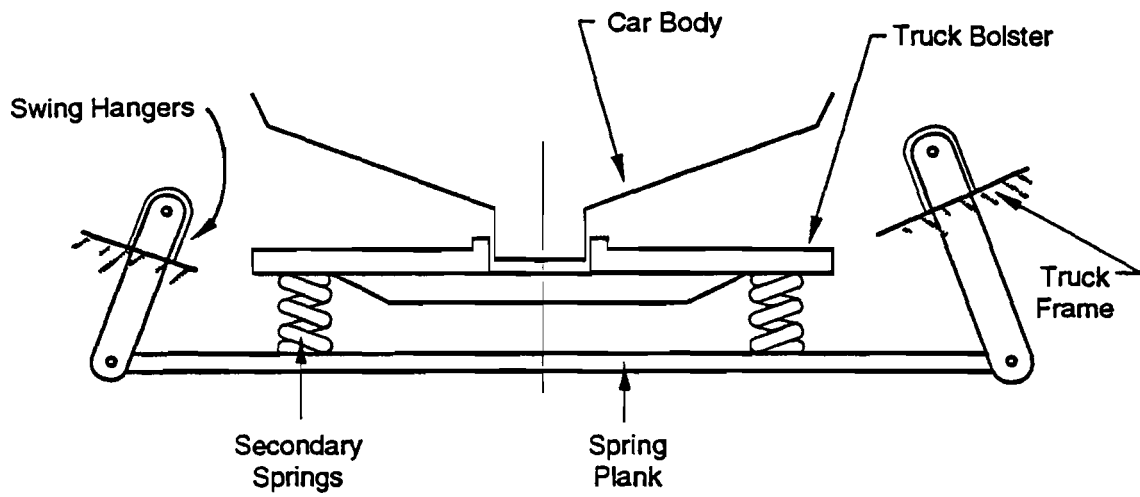


Figure 2.12a Swing-Hanger, Center Pivot

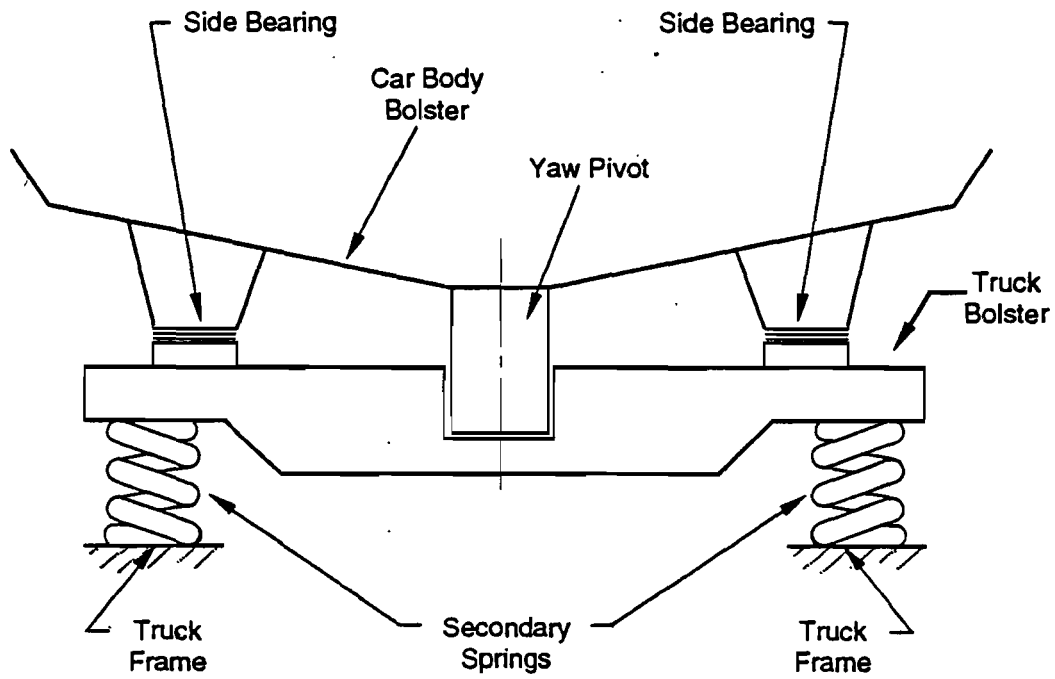


Figure 2.12b Upper Yaw Pivot

Figure 2.12 Secondary Suspension Arrangements

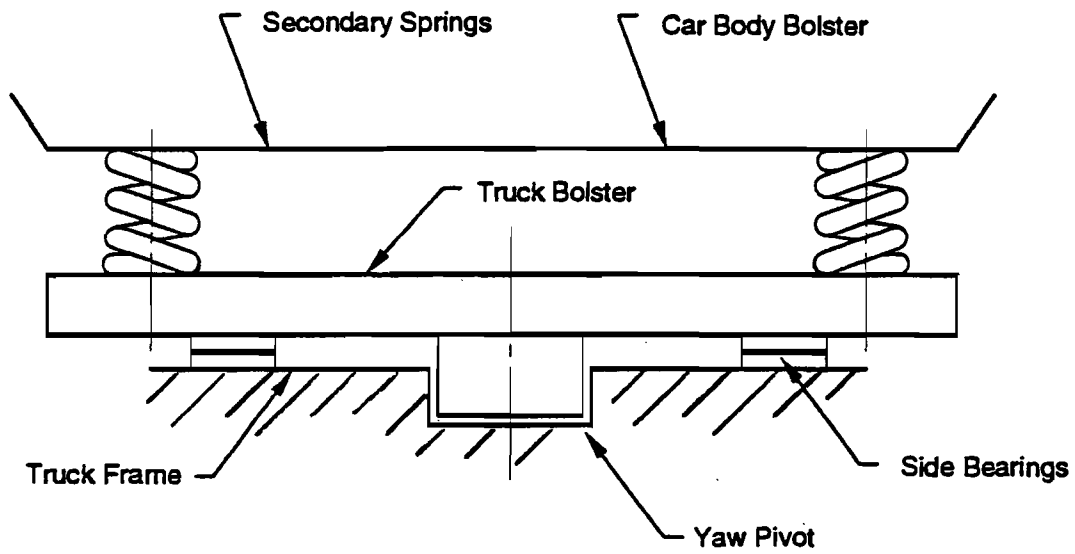


Figure 2.13a Lower Yaw Pivot

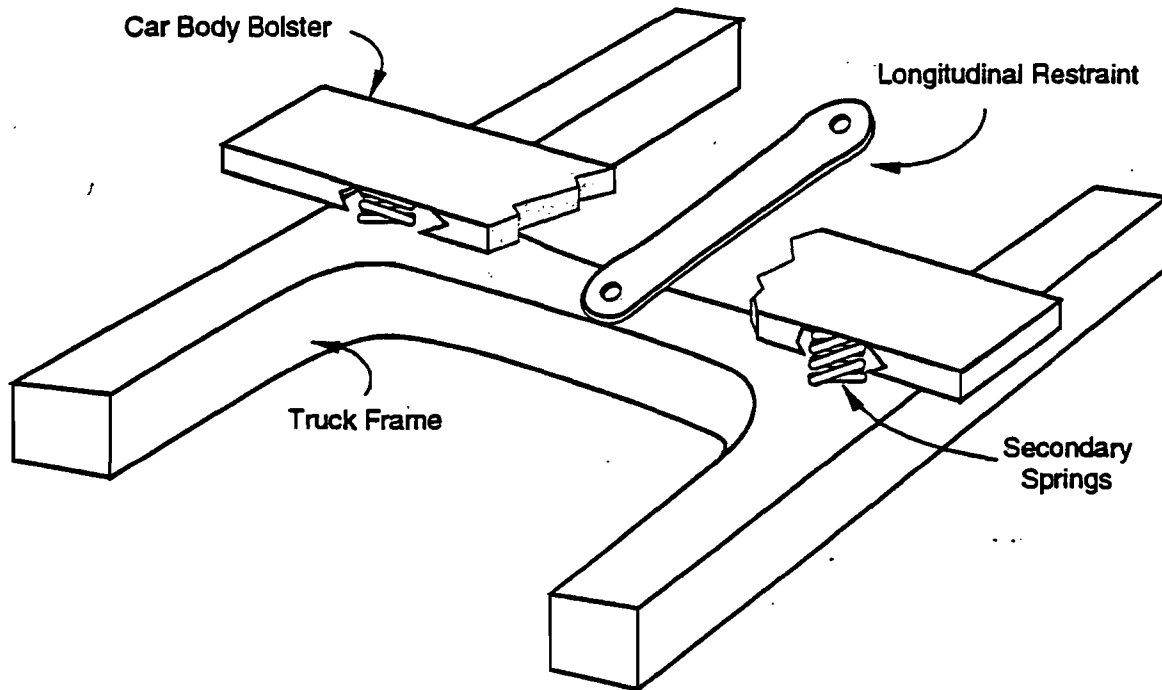


Figure 2.13b Pivotless, Bolsterless Arrangement

Figure 2.13 Secondary Suspension Arrangements

### **2.3.3.1 Traditional Swing Hanger, Center Pivot Truck (Figure 2.12a)**

In this arrangement, the car body is supported on a center pivot and a transverse bolster. The bolster is attached longitudinally and in yaw to the truck frame by two laterally-spaced traction links. The bolster rests on secondary springs which in turn rest on a transverse spring-plank suspended from the truck frame on swing hangers. The lateral suspension is provided by lateral deflection of the swing hangers. Lateral stiffness is dependent on hanger length, with a lower stiffness being provided by longer hangers. The swing hanger may be vertical, or slightly inclined. Inclination outward from the truck frame to the swing plank tends to tilt the car body in the opposite direction to the lateral movement of the swing hanger, and offsets the tendency of a car body to roll outward on the secondary springs when operating in a curve with cant deficiency. This truck arrangement was almost universal on cars built in North America and Europe prior to the late 1960s, but has been little used since.

### **2.3.3.2 Upper Yaw Pivot Arrangement (Figure 2.12b)**

This arrangement is similar to the traditional arrangement described in Section 2.3.3.1 above, but the swing hangers are omitted, and lateral suspension is provided by lateral shear of the secondary vertical springs, and further controlled by lateral bump stops to increase stiffness as the limit of allowable lateral movement is approached. The bolster is tied longitudinally and in yaw to the truck frame by longitudinal links.

### **2.3.3.3 Lower Yaw Pivot Arrangement (Figure 2.13a)**

This arrangement reverses the secondary spring/pivot sequence of the upper yaw pivot arrangement. The car body rests directly on the secondary springs which in turn rest on a transverse bolster. The bolster rests on a center pivot on the truck frame, and is tied to the car body longitudinally and in yaw by longitudinal links. The benefit of the lower yaw pivot arrangement over the upper yaw pivot is that the secondary springs are higher relative to the car body center of gravity, reducing outward roll when curving with cant deficiency. Also geometrical clearances are often such that the lateral spacing of the springs can be increased with the higher location. This arrangement has been widely used on trucks placed in service in the U.S. since about 1970.

### **2.3.3.4 Pivotless, Bolsterless Arrangement (Figure 2.13b)**

In this arrangement, the car body is supported on springs which are mounted directly on the truck sideframe without the use of a bolster. Without the bolster to transmit longitudinal loads and to provide the yaw pivot, the bolsterless truck achieves car body to truck pivoting by shearing the secondary springs, and longitudinal loads are carried by a separate longitudinal connection. This connection can be a simple longitudinal link, a rubber/steel sandwich element which is stiff longitudinally but soft laterally and vertically, or a "Watts" linkage (Figure 2.14a). This truck design is widely used in Europe, but has had very limited application in the U.S.

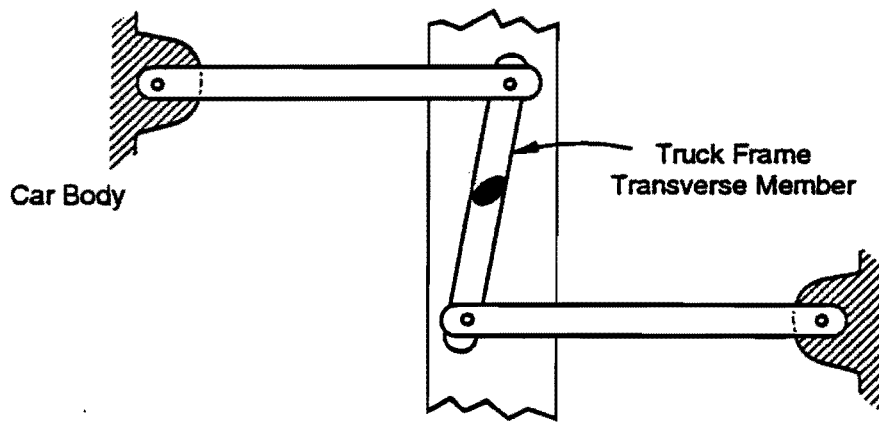


Figure 2.14a Watts Linkage for Longitudinal Restraint

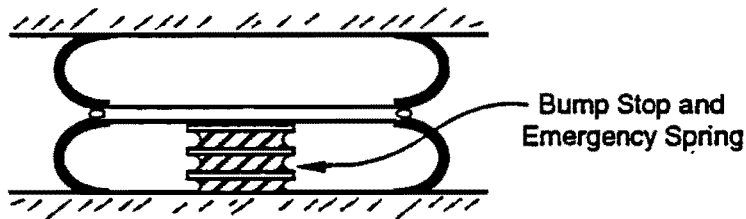


Figure 2.14b Bellows Air Spring

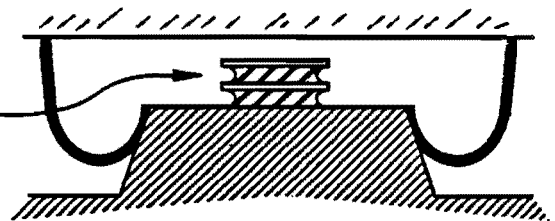


Figure 2.14c Rolling Diaphragm Air Spring

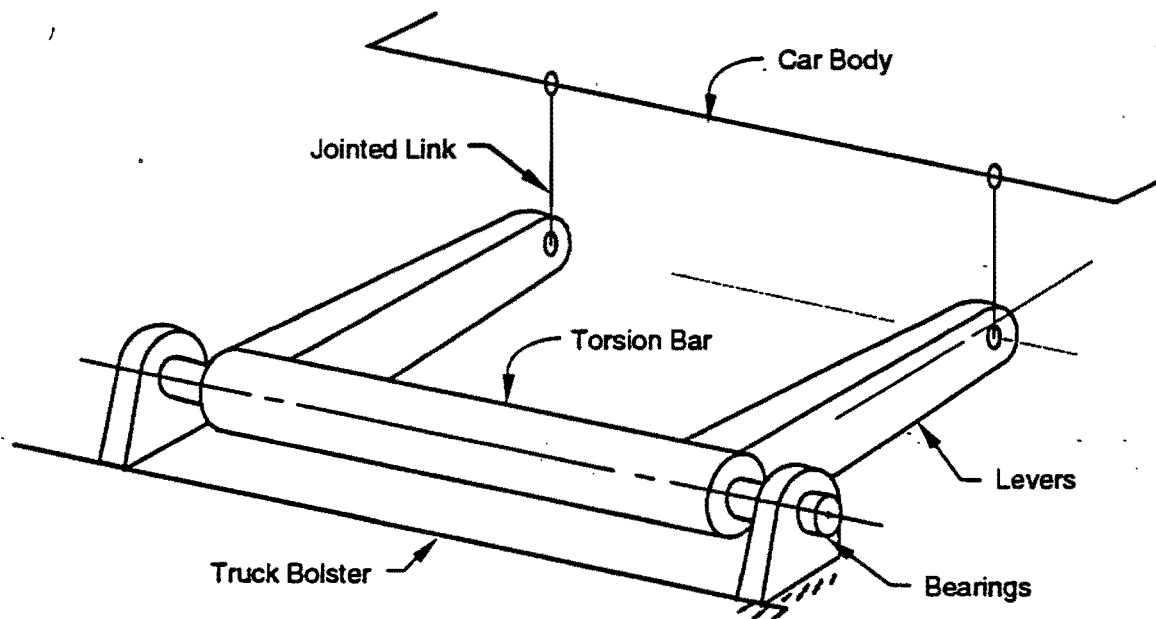


Figure 2.14d Anti-Roll Bar

Figure 2.14 Suspension Components



### 2.3.3.5 Secondary Springs

Either steel coil or air springs are used in combination with any of the four secondary suspension configurations. When mechanical coil springs are used, they are generally combined with elastomeric pads to minimize the mechanical vibration transmitted through the steel springs or generated by spring surge. Mechanical and elastomeric springs sometimes are combined to generate non-linear spring rates to reduce the displacement under load, while maintaining the resonant frequency nearly fixed.

Air springs are divided into two basic types: the bellows type spring and the rolling diaphragm type spring (Figures 2.14b and 2.14c). The bellows type springs have significant increases in the effective area under compression, and soft lateral spring rates. The rolling diaphragm type spring can provide a variety of positive or negative effective area changes with compression depending upon the design of the pedestal upon which the springs roll. The lateral spring rate is a function of the spring diameter and the shape of the diaphragm, the cover and the pedestal. Stiffness of all air spring variants is also a function of the air volume in the spring - the greater the volume the lower the stiffness. Air reservoirs, sometimes using the interior of the truck frame or bolster structure, are connected to the air spring interior to increase the effective volume inside the spring and reduce air spring stiffness.

Since air springs are subject to failure in service, provision must be made for the vehicle to operate safely with the springs deflated. The customary method is to use a rubber/steel sandwich spring situated inside or below the air spring to provide an emergency suspension. The vehicle must be able to operate safely on the emergency spring at maximum speed, but ride quality may be degraded.

When air springs are used, the floor height of the car body is controlled by levelling valves which admit compressed air to the springs when floor height is too low and release air when the floor is too high. Thus, constant floor height is maintained regardless of the load carried by the car. Levelling valves also have a small dead band [about 5 mm (0.2 in)] either side of the set level, to prevent excessive air due to constant admission and release of air with normal suspension movements.

There are three arrangements of levelling valve in use, having 2, 3, or 4 valves on a car. With two levelling valves, one valve controls the height of both air springs on each truck. With this arrangement, the two springs on a truck are controlled to have the same air pressure. The static roll stiffness derives only from the change of cross section area of the air spring with vertical compression, and depends on the air spring design used. This means that with the two levelling valve arrangement, a car will roll on the secondary springs when subject to a static roll load. Examples of this situation are when there is a lateral unbalance of passenger load or when traversing a long curve with cant deficiency. Dynamic air spring stiffness is unaffected, as the air pipe between the springs is usually too small to transfer significant air volumes under dynamic conditions.

In a three levelling valve arrangement, one truck has a single-levelling valve and the other truck has a valve at each air spring. On the truck with two valves, an air pressure differential can be maintained between the two air springs to react any lateral load imbalance and keep the car upright (i.e., with the floor parallel to the plane of the rails). Such lateral load imbalance, including that from cant deficiency in curves, is reacted only by the truck with two levelling valves. The two air springs on the two-valve truck are connected by an air line containing a

crossover or relief valve, which allows air to pass if the pressure differential exceeds a preset value, normally a little greater than any differential likely to occur in normal service. The function of this valve is to ensure that both air springs deflate if there is a failure of one air bag or levelling valve, thus preventing the dangerous condition of having an inflated and a deflated air bag on the same truck. The three-valve arrangement is widely used on air spring cars in the U.S.

With four levelling valves, both trucks have the two-valve arrangement as described for the three-valve arrangement. This system has the advantage that static roll imbalances are shared by both trucks instead of being reacted by one truck, as in the three-valve arrangement. The disadvantage of the four-valve arrangement is that valve height settings for air admission and release have to be carefully adjusted to prevent a situation where air is admitted to diagonally opposite springs to correct an apparent but non-existent static roll deflection. This situation reduces the static load on diagonally opposite sides of the two trucks, and is potentially dangerous.

Where the roll stiffness of the secondary suspension is too low for adequate stability under roll and curving forces, an anti-roll bar can be installed in parallel with the secondary suspension. Typically, the anti-roll bar system consists of a torsion bar attached to the bolster or car body with bearings at each end (Figure 2.14d). Attached to the roll bar are horizontal levers with jointed links to the car body or bolster respectively. When a roll motion occurs between the bolster and the car body, the horizontal levers are rotated in opposite directions. This motion is resisted by the torsion bar, providing increased roll stiffness. Under vertical motions, the horizontal levers rotate in the same direction, rotating the torsion bar within its bearings and applying no force across the secondary suspension.

#### **2.3.3.6 Secondary Vertical and Lateral Dampers**

The use of hydraulic dampers or shock absorbers to achieve correct lateral and vertical damping is almost universal in modern truck designs. The vertical dampers are connected in parallel to the secondary springs, and the lateral dampers in parallel with swing hangers or the secondary lateral spring. Rubber end bushes are used to reduce the transmission of higher frequency vibration and noise through the dampers.

Where air springs are used, it is possible to provide partial vertical damping by restricting air flow between the air spring itself and an adjoining air reservoir. The damping effect is produced by pumping air through the restricting orifice.

#### **2.3.3.7 Yaw Restraint**

The truck designer is presented with conflicting requirements with regard to yaw restraint between the truck and the car body. A stiff yaw restraint is desirable for good dynamic stability and high critical speed, but the truck has to be able to swivel to negotiate curves. The truck pivot, where used, is usually lined with a bearing material that needs a considerable applied yaw torque to become "unstuck" and move. While the pivot is "stuck" the truck has a stiff yaw restraint via longitudinal traction rods positioned in series to the yaw pivot. Rubber bushes in the traction rod ends, and the brackets to which the traction rods are attached provide the yaw restraint at loads below the pivot break-out force.

Bolsterless trucks without a center-pivot to provide yaw restraint are nearly freely-pivoting, with restraint only provided by the low longitudinal shear stiffness of the secondary springs. This stiffness is far too low to have a significant effect on truck stability. For low or moderate speed operation, such as a commuter train, stability may be attainable without additional yaw restraint, and only careful adjustment of primary lateral and longitudinal suspension stiffness is needed. However, at high speed additional secondary yaw restraint is essential, and hydraulic secondary yaw dampers are commonly used on bolsterless trucks.

## **2.4 TRUCK AND CAR DESIGNS WITH SPECIALIZED FEATURES**

This section provides descriptions of truck and car designs having specialized features, other than those found in the basic two-axle truck applied to a conventional single-level passenger car. With the exception of bi-level car body designs, application of cars and trucks with these features in the U.S. has been confined to test and demonstration service.

### **2.4.1 Bi-Level Car Body Designs**

Bi-level car body designs are finding increasing use in the U.S. and elsewhere. Bi-level designs are economically attractive for passenger rail service operators; the space available for passenger accommodation is increased with a less-than-proportional increase in cost, train weight, and train length, thus lowering capital and operating cost per passenger. The principal barrier to using bi-level cars has been restricted height clearances on some routes. However, in recent years innovative car designs, clearance improving efforts on some routes, and a reduction in the space occupied by power and auxiliary systems on cars have all widened the scope for application of bi-level cars. It is likely that a majority of cars purchased in future years will be of bi-level design.

The significance of bi-level cars for truck design is that the trucks have to carry the greater weight of the bi-level body, which is typically of the order of 50% heavier than a single-level body. Additionally the car body center of gravity can be higher, potentially imposing higher roll moments on the suspension. Particular care in car design has to be taken to ensure that roll deflections of a bi-level car, for example while negotiating a curve with cant deficiency, are not excessive and do not violate clearances or comfort criteria.

There are three common bi-level car body layouts used in the U.S., as illustrated in Figure 2.15. The first layout, with doors and entrance vestibules at the ends of the car, and at the same floor height as a single-level cars, is shown in Figure 2.15a. The bi-level portion is situated between the trucks. This layout is well suited to commuter operations; it can be coupled to single-level cars and used with both high and low platforms. Wide, short stairways to the upper and lower levels allow good passenger flow at stops. Cars purchased in recent years for commuter service in Boston, New York (Long Island), southern Florida, and southern California have this layout.

Figure 2.15b illustrates the layout of bi-level long distance intercity cars operated by Amtrak. This layout has a full length upper level, with access to adjacent cars being at the upper level. A lower level is situated between the trucks, with entrance doors and stairs to the upper level. Auxiliary equipment is housed in the spaces above the trucks. Having doors on the lower level means that this layout is not compatible with high platforms.

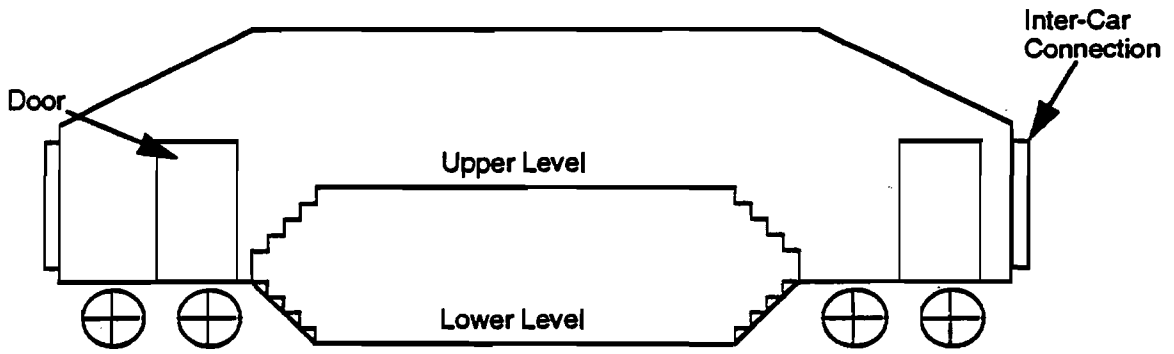


Figure 2.15a Car End Floor at Conventional Height

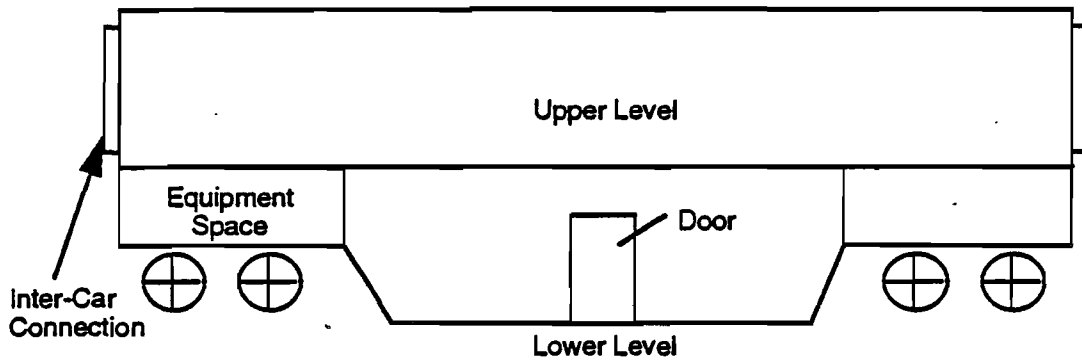


Figure 2.15b Full Length Upper Level

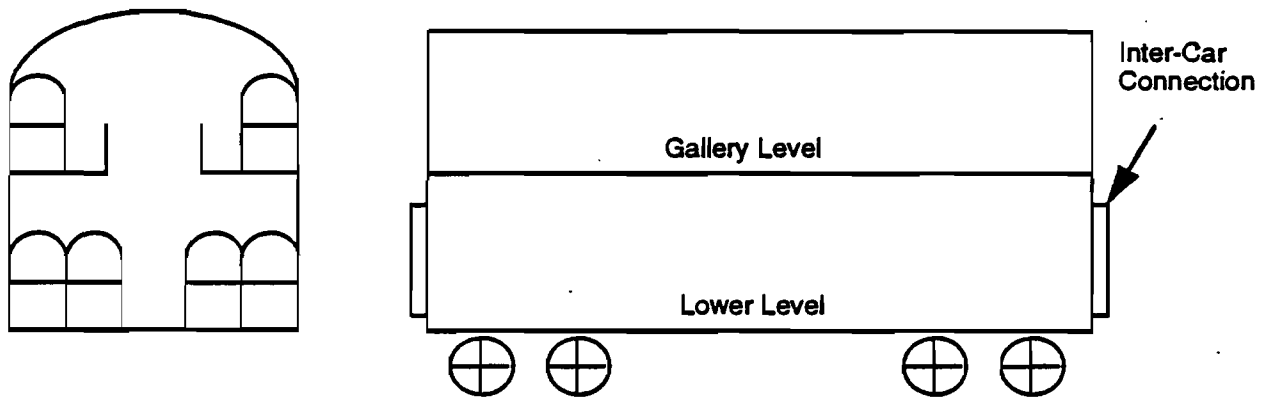


Figure 2.15c Gallery Car

Figure 2.15 Bi-Level Car Layout

Figure 2.15c illustrates the cross section of a gallery type bi-level car which is extensively used on commuter services in Chicago. Gallery cars have a lower level with the same floor height as single-level cars. The upper level consists of narrow galleries on each side of the car containing single seats and a walkway. The space between the galleries provides headroom for walking in the center gangway of the lower level.

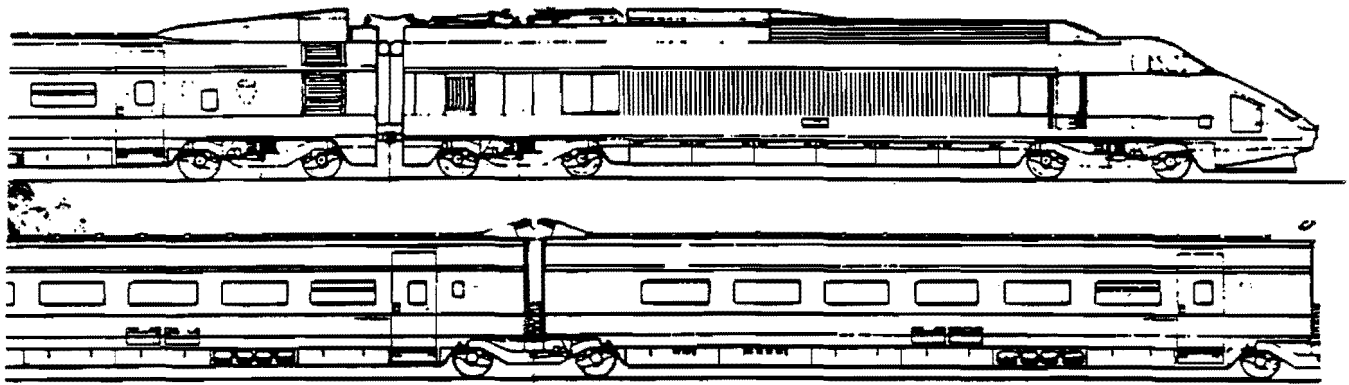
#### **2.4.2 Articulated Trainsets**

In an articulated trainset, the ends of adjacent vehicles in a trainset are supported on a single truck. The truck can be an otherwise conventional two-axle truck, as in the French TGV trains, or a single-axle truck, as in the Spanish Talgo Pendular. These applications of passenger car articulation are illustrated in Figure 2.16. Other applications of articulation include light rail transit vehicles and several designs of intermodal freight cars used on U.S. railroads. A principal advantage of articulation is that the total number of trucks or suspension units needed in a train of a given size is reduced, at a saving in weight and cost. Articulated trains may also be less likely to buckle or override in a collision due to the greater restraint provided by the articulation joint as compared with a conventional coupler. The primary disadvantage of articulated trainsets is that it is more difficult to separate a single car from the train for maintenance or in the case of a failure, potentially increasing maintenance costs and car downtime.

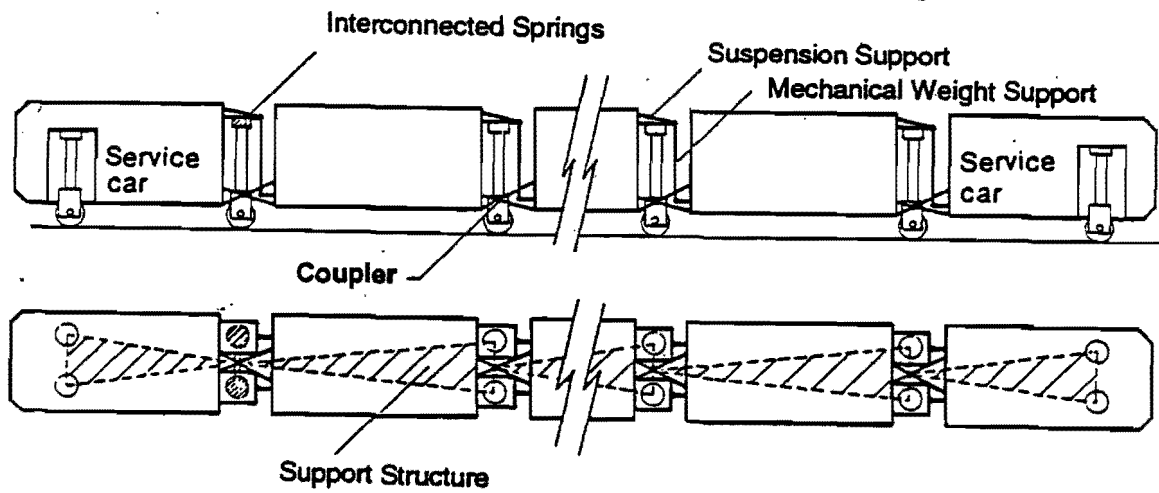
Truck designs for articulated trains differ little from those for use with independent cars. Truck structures must be designed to support the weight of the two car bodies and the secondary suspension attachments to the cars must be compatible with the inter-car connector arrangement used. Otherwise the truck functions exactly as a truck on a single car. A potential advantage of articulation on very high-speed trains is that the increased load supported by an articulated truck increases the ratio of car mass supported to truck mass, making it easier to attain lateral dynamic stability at high speed. This consideration is believed to have been a factor in the original choice of articulation for the TGV.

#### **2.4.3 Single-Axle Trucks**

With a single-axle truck, the car body is directly supported on a single-axle and each axle has an individual suspension system, as shown in the sketches in Figure 2.17. The suspension may be single stage, or have separate primary and secondary elements. The primary benefit of single-axle suspensions is that they offer the potential for weight saving relative to a two-axle truck. A notable application of the single truck to railroad passenger cars is the Spanish Talgo Pendular train, illustrated in Figure 2.16. Single-axle suspensions have also been used in some freight car designs, and in innovative transit and commuter car designs in Europe.

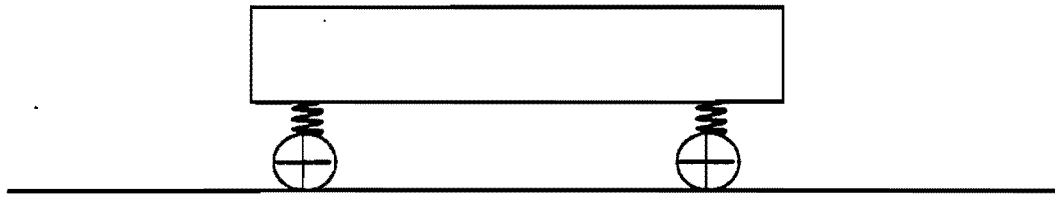


**Figure 2.16a French TGV Articulation Arrangement with Independent Power Cars**

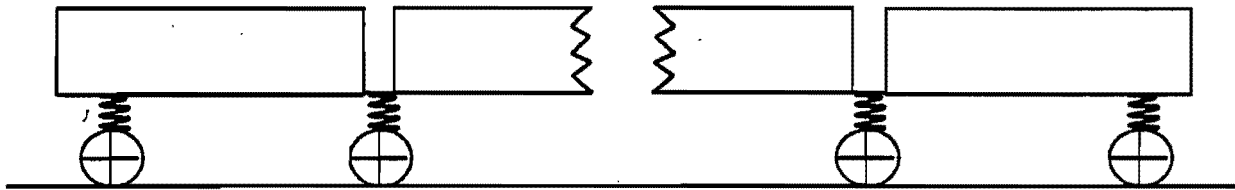


**Figure 2.16b Spanish Talgo Single-Axle Articulation Arrangement**

**Figure 2.16 Articulation Arrangements  
[Illustrations from Manufacturers Literature]**



**Single Independent Car**



**Articulated Trainset (e.g., Talgo)**

**Figure 2.17 Single-Axle Suspensions**

#### **2.4.4 Independent Wheel Suspensions**

In the conventional railcar wheel set, the wheels are solidly attached to the axle. An alternative is for each wheel to rotate independently on its own bearings, and to dispense with the solid axle. The benefits of dispensing with the axle are to free up space between the wheels for other equipment or a low floor passageway, and to remove the risk of dynamic instability due to the action of profiled wheels on a solid axle. However, removing the solid axle also removes the steering action of the conventional wheel set, thus some substitute steering mechanism is likely to be required with any independent wheel suspension.

The most notable application of independent wheels to a railroad passenger equipment is the Spanish Talgo Pendular. The suspension design philosophy for the Talgo Pendular combines a low center of gravity for the car body with passive tilt, articulation and forced steering of the independent-wheel suspension units, as illustrated in Figure 2.18. Independent wheel suspensions are also used in several designs of low-floor streetcar and light rail vehicle.

#### **2.4.5 Steering Trucks**

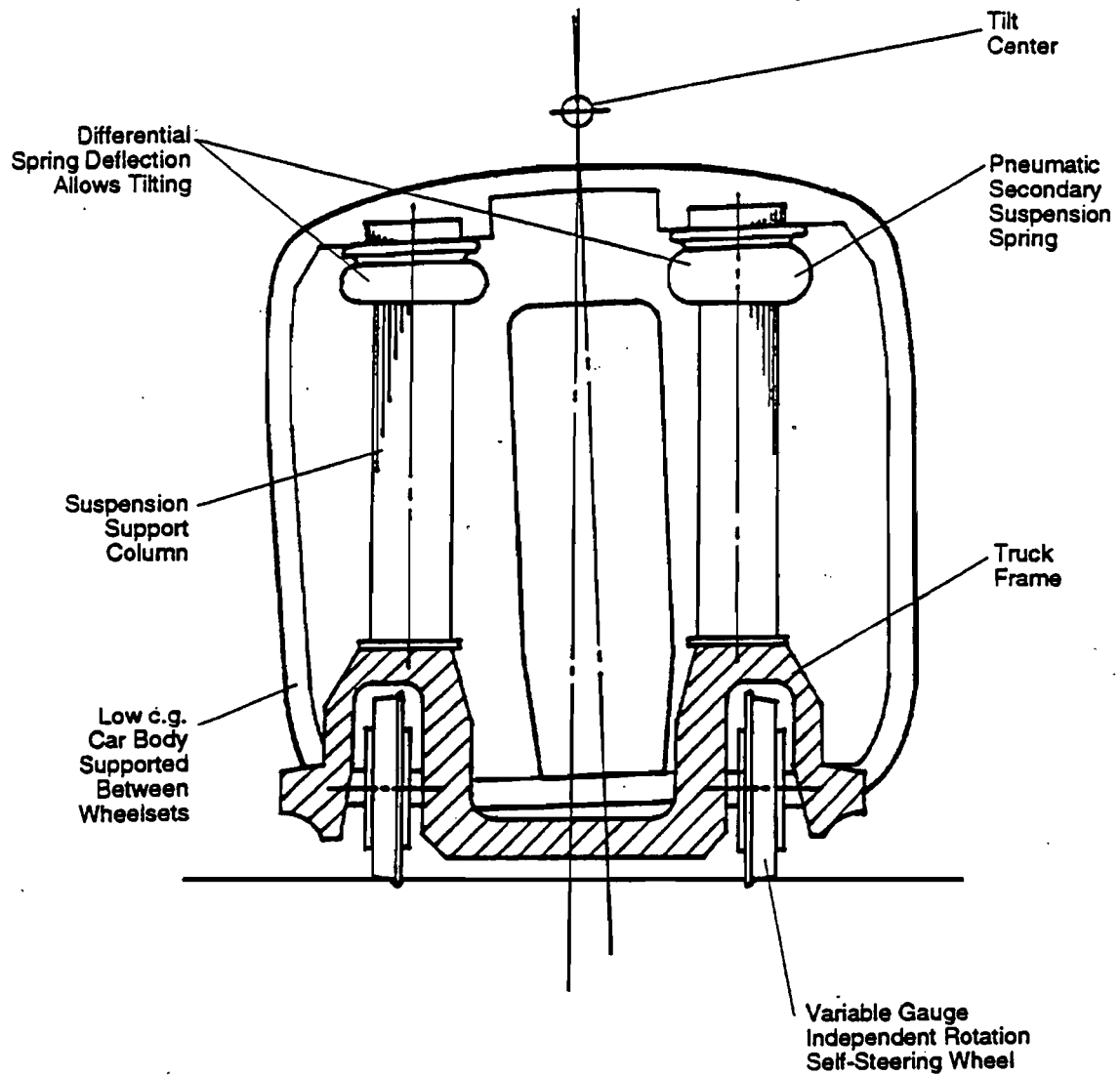
##### **2.4.5.1 Passive Steering**

Passive steering is achieved by interconnecting the axles of a truck so as to allow relative yaw movements at the same time as providing a high stiffness against relative shear of the axles. The action of wheel-rail forces causes the wheel set to take up a radial attitude in curves. Alternative mechanical arrangements to achieve passive steering are shown in Figure 2.19a. The benefits of passive steering are that curving performance can be improved, compared with that achievable with a similar truck lacking the axle interconnections, without degrading dynamic stability. Trucks that achieve improved curving performance by careful selection of primary yaw and lateral suspension stiffnesses, but which lack axle interconnections, would not be termed a steering truck under this definition, although manufacturers will sometimes call such truck a steering or radial truck.

One novel approach to passive steering is used in the ABB X2000 tilt train. Passive steering of the axles is permitted by having a soft primary longitudinal suspension. Then instead of using interaxle connections to achieve the required dynamic stability, primary longitudinal dampers are used in parallel to the primary longitudinal springs.

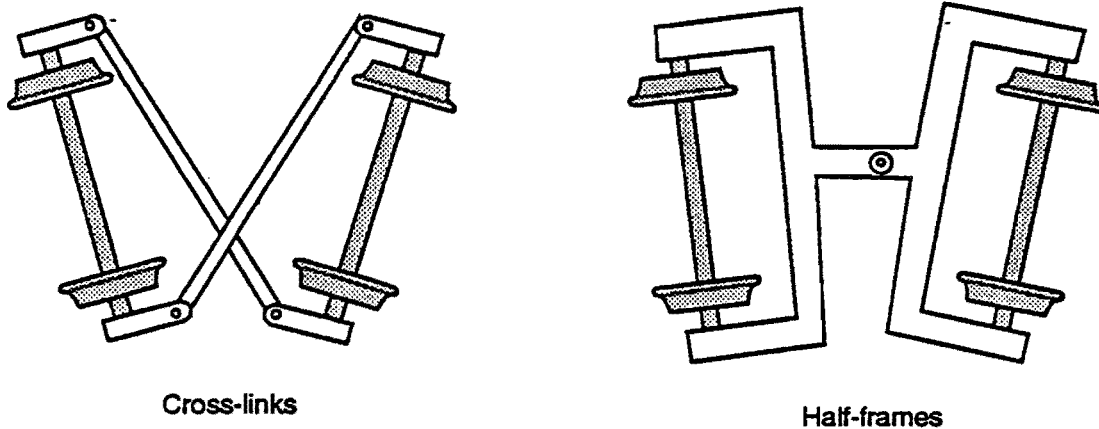
Other than the X2000, passive steering has not been much used on railroad passenger car trucks. The widest application has been to three-piece freight car trucks, where substantial reductions in wheel and rail wear on heavily curved routes have been demonstrated. In the application to three-piece trucks, axle interconnection prevents undesirable 'parallelogramming' of the independent truck sideframes, as well as facilitating radial steering.



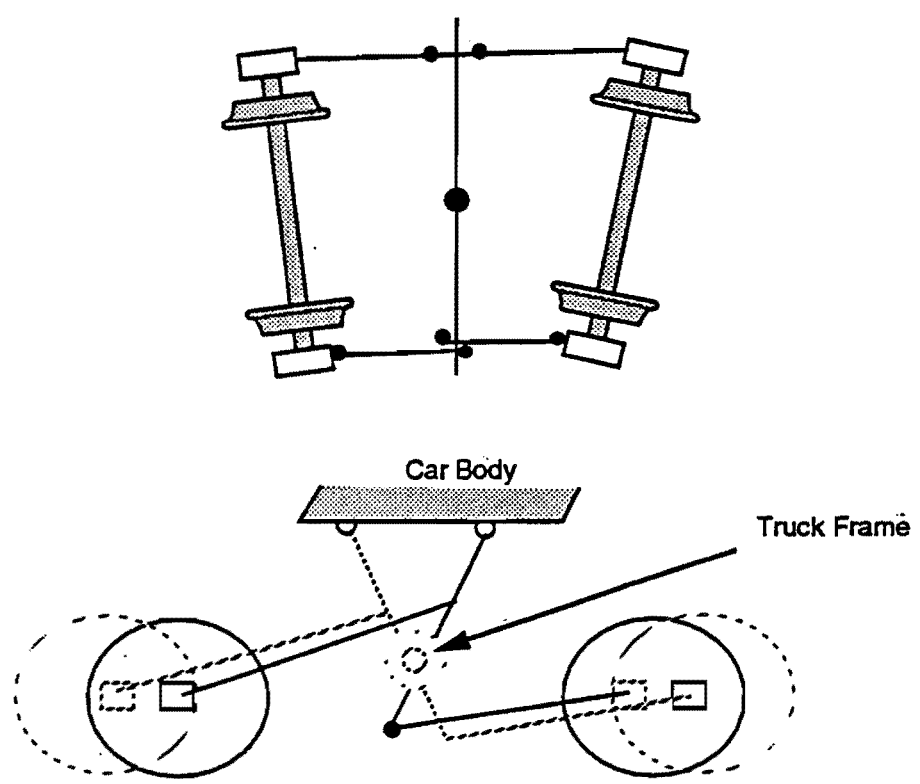


**Figure 2.18 Talgo Suspension System Showing Independent Wheels**

[Source: Reference 6]



**Figure 2.19a Alternative Passive Steering Interconnection on a Two-Axle Truck**



**Figure 2.19b Forced Steering on a Two-Axle Truck**

**Figure 2.19 Truck Axle Steering Systems**

### **2.4.5.2 Forced Steering**

Passive steering works through allowing the longitudinal and lateral creep forces at the wheel-rail interface to move the axles to an approximately radial attitude in curves. Forced steering uses linkages between the car body, truck frame and axles to force the axles into a radial position. The yaw rotation of the car body relative to the truck frame can be used through a truck-frame mounted mechanism to produce axle yaw, as illustrated in Figure 2.19b. An alternative mechanical arrangement, used in the Spanish Talgo train, is to use a linkage to cause the axle to bisect the angle between car bodies at the articulation point.

Apart from the Talgo mechanism, forced steering has not been much used in railroad passenger cars, although applications exist in other types of rail vehicle, especially in light rail vehicles which have to negotiate very tight curves.

### **2.4.6 Body Tilt Suspensions**

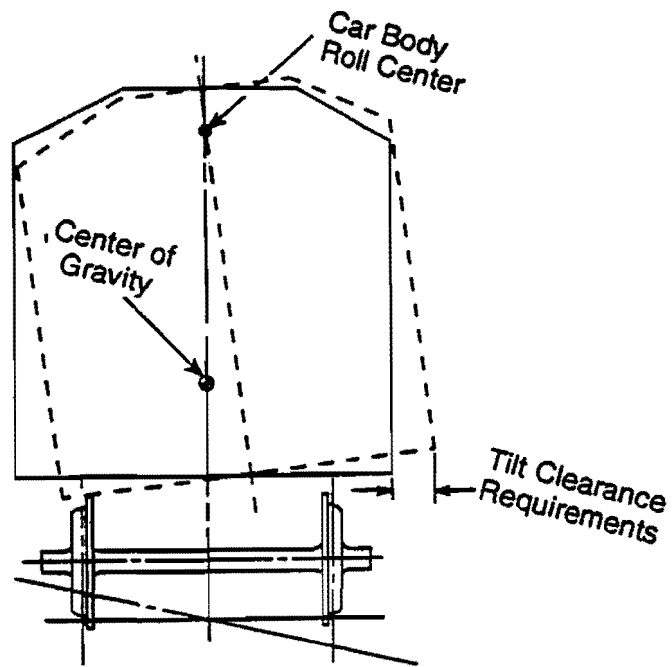
Car body tilt systems tilt the car body laterally in curves to reduce or eliminate the lateral force felt by car occupants when a curve is negotiated with cant deficiency. Tilt mechanisms are usually incorporated into the truck, and are a major factor in truck design for tilt trains. The purpose of tilt is to improve passenger comfort and thus allow higher speed curving than would otherwise be possible with given passenger comfort criteria. Tilt systems do not change substantially the risks of a car overturning or derailment on curves. Established safety criteria for lateral forces on track and overturning moment must still be observed.

Car body tilt suspension systems were the subject of a survey conducted for the FRA [Reference 6]. Therefore, only very brief descriptions of the main types of tilt system will be given, based on this previous report.

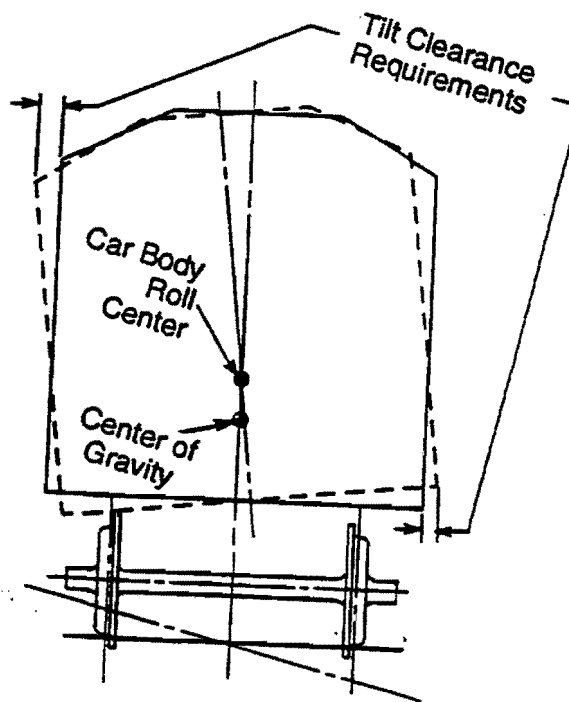
#### **2.4.6.1 Passive Tilt Systems**

Passive tilt systems rely on the pendulum effect provided by centrifugal and gravity forces when the car body roll center is placed well above the car's center of gravity. The car body behaves as though it is suspended from a longitudinal axis near the top of the car, causing it to swing outward when negotiating a curve with cant deficiency, as shown in Figure 2.20a. Passive tilt systems have the advantage of mechanical simplicity, but the high roll center can mean a large outward movement of the center of gravity, eroding the safety margin against overturning, and large lateral movements at floor level which may be difficult to accommodate within allowable clearances. Also, passive pendular systems may not respond as quickly as active systems to the spiral at the entry of curves, thus subjecting car occupants to a transient lateral acceleration and adversely affecting ride comfort.

Train and car designs using passive tilt include the Talgo Pendular, the Japanese Series 381 electric multiple-unit train for service on meter-gauge lines, and the United Aircraft Turbo trains operated in the U.S. and Canada in the 1970s and early 1980s.



**Figure 2.20a** Passive Tilt, High Roll Center



**Figure 2.20b** Active Tilt, Low Roll Center

**Figure 2.20** Car Body Tilt System Arrangements  
[Sources: Reference 6]

### **2.4.6.2 Active Tilt Systems**

In active tilt systems, body tilt is produced by a powered actuator situated between the car body and the truck frame in response to control signals provided by sensors indicating the presence of a curve. A wide variety of mechanical arrangements of actuators, secondary suspension elements and linkages are used in different tilt train designs to produce rotation about the desired tilt center. Likewise a variety of sensor types and locations and signal processing algorithms can be used to provide optimum passenger comfort over the range of track conditions encountered in service.

The advantages of active tilt are the ability to tilt about a point near the center of gravity, eliminating undesirable outward movement of the center of gravity (as shown in Figure 2.20b), and the flexibility of control strategies to optimize passenger comfort. The primary disadvantage of active tilt is its complexity, which adds to capital and maintenance costs and can detract from reliability. Many difficulties were encountered by tilt system developers in evolving satisfactory control systems, combining reliability with acceptable safety and comfort performance.



### 3. SUMMARY DESCRIPTIONS AND DATA FOR MAJOR AND DISTINCTIVE TRUCK DESIGNS

#### 3.1 INTRODUCTION

This chapter is the core of the report, containing information on the population of different truck designs in the U.S., and introducing the descriptions and data for selected truck designs. The approach used is to present summary data, with observations on the population and highlighting the similarities and differences between the selected designs. The full data are provided in two appendices, Appendix 1 for the truck descriptions and data, and Appendix 2 for the population data. Both the truck population and the truck data and descriptions are referenced to a truck classification system, described in Section 3.2.

#### 3.2 CLASSIFICATION OF TRUCK DESIGNS

A system of classifying truck designs has been developed for this study, distinguishing between truck design features that may affect truck performance in the widest sense. Trucks having a given classification under the system may be regarded as being distinctive, in that they have a unique arrangement of rigid structural components and connecting elements (such as springs, dampers, and connecting rods) that control the kinematic relationship between the structural components.

The *primary division* in the classification system is by truck frame type and equalization method, indicated by the number  $n_2$  in the code below. The *secondary division*, indicated by the number  $n_3$  in the code, indicates variants within a specific truck frame type and/or different secondary suspension arrangements. Other truck characteristics such as use of inboard or outboard journal bearings, whether or not one or more axles of the truck are powered, and whether or not the truck is fitted with a body tilt system or wheel set steering, are indicated by added letters.

The basic classification code is as follows:

$n_1 n_2 n_3 a_1 - P_{n_4} S_{n_5} T_{n_6} W$

where:

- $n_1$  the number 1 in this location indicates a 3-axle truck. No number is shown in this location for 1- and 2-axle trucks, and truck-frame type classifications for 3-axle trucks are the same as for 2-axle trucks.
- $n_2$  is a number between 0 and 9 identifying the primary classification of truck frame type and equalization method.
- $n_3$  is a number between 0 and 9 indicating variants on the primary classification, especially different secondary suspension arrangements.
- $a_1$  indicates whether the journal bearings relative to the wheel location are internal (i) or external (e) (internal and external bearings are also referred to as inboard and outboard bearings). Journal bearing location does not affect the kinematic relationships between major truck components, but can significantly affect the numerical values of suspension parameters.
- P indicates that the truck is powered. The number of powered axles is indicated by the suffix  $n_4$ .

S indicates the presence of axle steering. Individual steering arrangements are indicated by the suffix n5:

- S<sub>1</sub> Passive interaxle steering using linkages or other means
- S<sub>2</sub> Forced steering using truck to body linkage

T indicates the presence of a car body tilt system. Individual tilt system arrangements are indicated by the suffix n6.

- T<sub>1</sub> Passive pendular tilt
- T<sub>2</sub> Active servo controlled tilt

W indicates the presence of independent wheels.

Table 3.1 lists the primary and secondary classifications chosen to represent all truck designs currently in operation on railroad passenger cars in the U. S., and all designs that are under consideration for application in the U.S. Note that all truck arrangements that have been used on or proposed for heavy rail mass transit or light rail applications are not necessarily covered by the classification.

The primary and secondary design classifications are further described in the following paragraphs and illustrations.

*Type 00* single-axle trucks have individual suspension systems between each axle and the car body. Single-axle trucks are used on two-axle cars, and in articulated arrangements. Historically, single-axle trucks have been little used in the U.S. on railroad passenger cars, the only recent application was the United Aircraft Company Turbotrain that operated in the Northeast Corridor and in Canada in the 1970s and early 1980s. The Turbotrain combined single-axle trucks with articulation, forced steering and passive tilt. More recently, there has been interest in applying the Spanish Talgo Pendular train design to selected intercity corridors, which also combines single-axle trucks with articulation, passive tilt and forced steering, and as well as having independent wheels. The Type 01 truck in the classification scheme represents the Talgo Pendular and similar truck designs.

Single-axle trucks have recently applied to innovative mass transit vehicles in Europe, such as the Paris Metro Boa trains, and Copenhagen commuter (S-Bane) trains built by Linke Hoffmann Busch.

*Type 10* trucks have independent sideframes, of the type used for all North American freight cars, and sometimes on baggage cars in passenger trains. The Type 11 truck in the classification represents the three-piece freight car truck, having a very stiff or rigid primary suspension, a bolster resting on secondary coil or leaf springs, and the car body resting on the bolster center pivot and sidebearings.

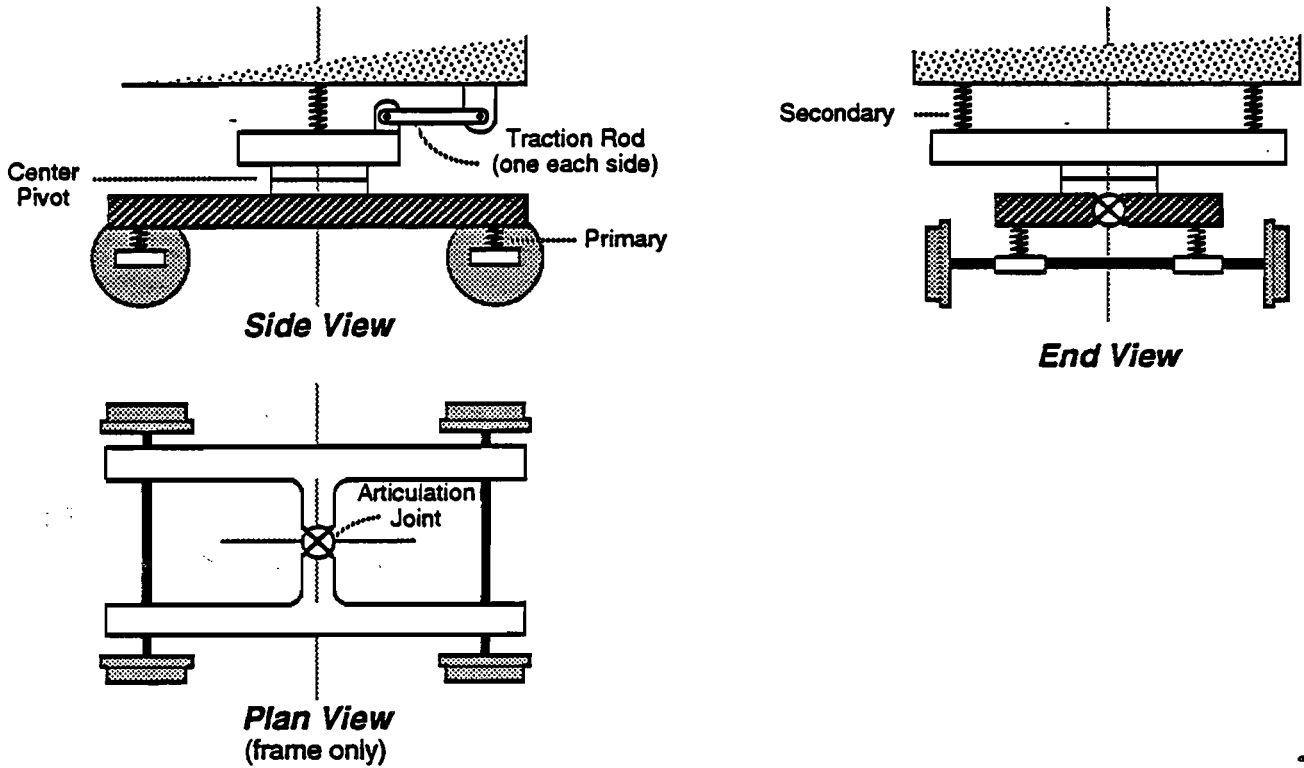
*Type 20* trucks have articulated truck frames that allow relative pitch between the sideframes to achieve wheel load equalization on twisted track. Figures 3.1a and 3.1b illustrate two arrangements of Type 20 trucks included in the classification.

- *Type 21* trucks have a combination truck-frame articulation ball joint and truck frame to bolster center pivot, as shown in Figure 3.1a. This arrangement is used on the Budd Pioneer truck design, applied to many intercity cars, and in powered form to some commuter cars. This design has also been used in mass transit applications.



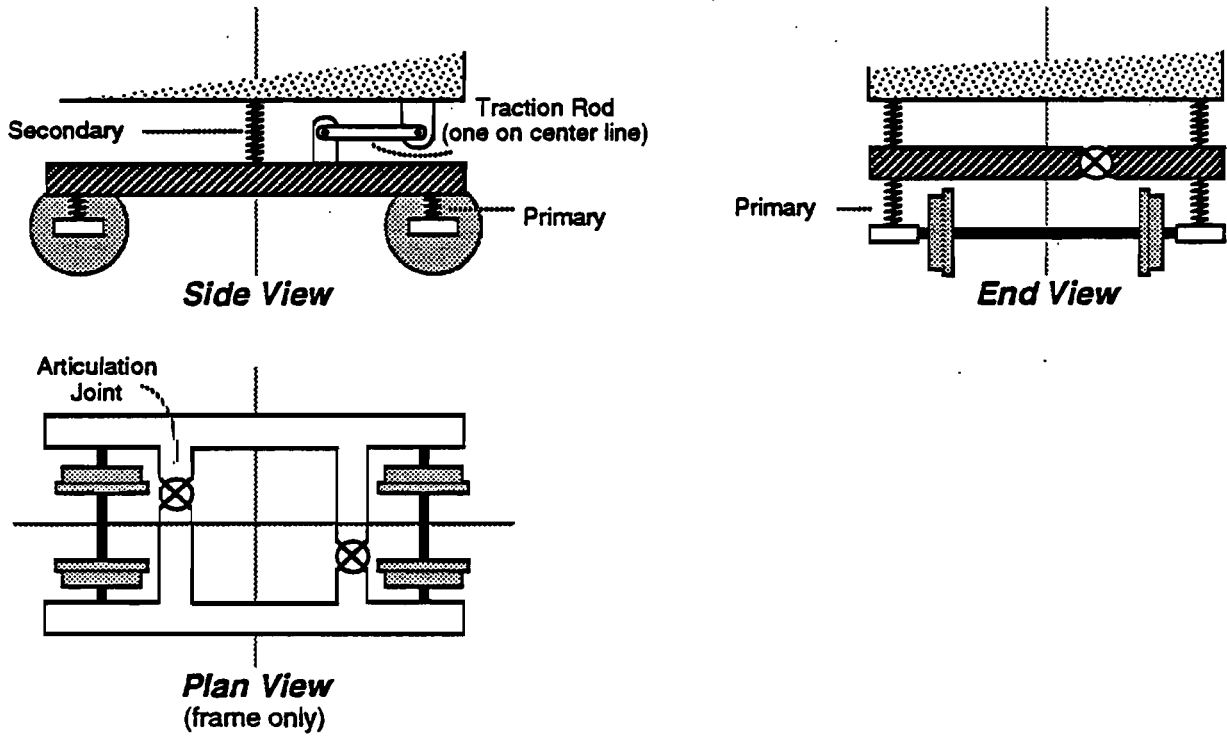
**Table 3.1 Principal Truck Design Classifications**

<b>Primary Classification</b>	<b>Secondary Individual Truck Types</b>	<b>Description</b>	<b>Example</b>	<b>Classification of Example Truck</b>
00 Single-Axle Truck	01	No primary suspension Bolsterless secondary suspension	Spanish Talgo	01-S <sub>2</sub> T <sub>1</sub> W
10 Independent Side Frames	11	3-piece freight truck	Some Amtrak baggage cars	11e
20 Articulated Frame	21 22	Single center articulation Ball joint in each transom	Budd Pioneer III Fiat Pendelino	21i or 21i-P <sub>2</sub> 22e-P <sub>2</sub> T <sub>2</sub>
30 Rigid Frame, Equalizer Beam Primary	31 32	Swinghanger/springplank/bolster Yaw pivot below secondary suspension	Traditional GSI truck GSI G70 series	31e 32i or 32i-P <sub>2</sub>
40 Rigid Frame, Journal Spring Primary	41 42 43	Swinghanger/springplank/bolster Yaw pivot below secondary suspension Bolsterless	MD76 (Superliner I) Nippon Sharyo NT319 Comeng/Tokyu Car	41e 42e 43e



**Figure 3.1a**

Type 21: Articulated frame with center ball joint and truck pivot



**Figure 3.1b**

Type 22: Articulated frame with ball joints in transoms and no bolster

**Figure 3.1 Schematics of Truck Types 21 and 22**

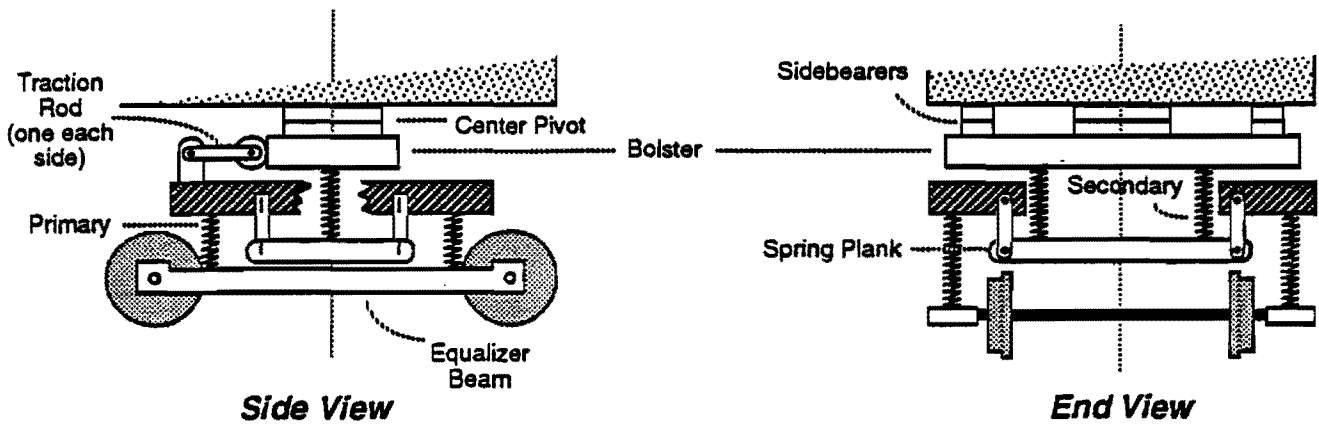
- *Type 22* trucks have a ball joint in each of two transoms (Figure 3.1b), allowing relative truck frame pitch about a diagonal axis. This arrangement is used on the Fiat ETR 450 series of tilt body trains for Italian State Railways, and also on a heavy rail mass transit truck manufactured by Rockwell, and used in San Francisco (BART) and Washington DC (WMATA). Note that subsequent series of Fiat tilt trucks, including the candidate for Amtrak high-speed trains for Northeast Corridor service, may have a different truck frame arrangement. Type 22 trucks may be bolsterless, as shown in Figure 3.1b, or have a bolster supporting the body through a center pivot (the Rockwell arrangement) or through the tilt mechanism (the Fiat arrangement)

*Type 30* trucks have a rigid truck frame supported on primary vertical springs situated inboard of the wheel sets. The lower ends of the springs rest on an equalizer beam which in turn is supported on the axle journal bearings. The equalizer beam effectively reduces the pitch and warp stiffnesses of the primary suspension. The good equalization has made Type 30 trucks the most widely used in the U.S. Two significant variations of the Type 30 are described below:

- *Type 31*, shown in Figure 3.2a, has a secondary suspension comprising swinghangers for lateral flexibility supporting a spring plank, which in turn supports the secondary vertical springs. A transverse bolster rests on the springs and supports the car body through a center pivot. Type 31 trucks were almost universally used in the U.S. prior to about 1970.
- *Type 32*, shown in Figure 3.2b, reverses the sequence of components in the Type 31 and eliminates the swinghangers and spring plank, so that the car body rests on the bolster through secondary vertical springs, and the bolster rests on the truck frame through a center pivot. The Type 32 is the most widely used arrangement in the U.S., with a number of variants (powered and unpowered, inside and external bearings).

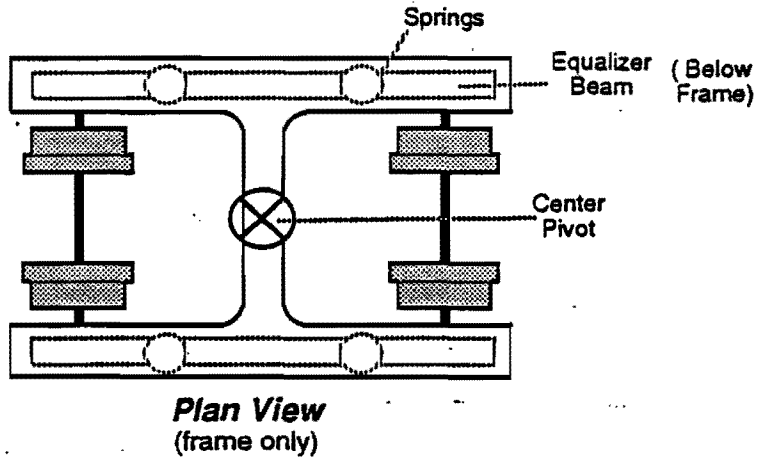
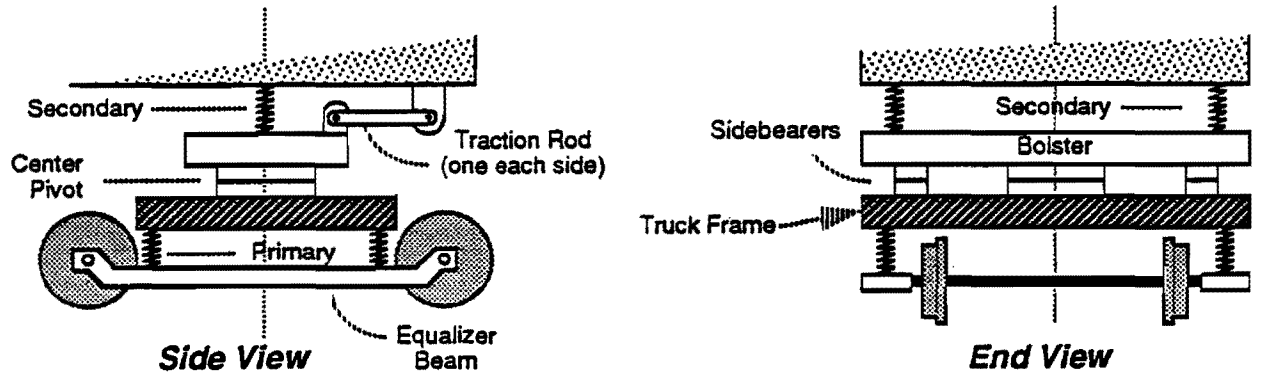
*Type 40* trucks are characterized by having the primary vertical suspension directly above or adjacent to the axle bearing journal box. Compared with Type 30 trucks, Type 40 trucks tend to have stiffer primary pitch and warp stiffnesses. Type 40 trucks are widely used in Europe and Japan, and are the principal arrangement of imported truck design in use or proposed for use in the U.S. There are three distinct arrangements of Type 40 truck, as described below and illustrated in Figure 3.3.

- *Type 41* trucks, shown in Figure 3.3a, have the same secondary suspension arrangement as the Type 31, with swinghangers, spring plank, secondary vertical springs, bolster, and center pivot. The only example of a Type 41 in the U.S. is the MD 76 truck used on Amtrak's Superliner I bi-level cars. Type 41 trucks were widely used in Europe until the 1970s, but have since been superseded by the simpler Type 42 and 43 trucks described below.
- *Type 42* trucks, shown in Figure 3.3b, have the same secondary suspension layout as the Type 32, with the bolster resting on the center pivot and secondary vertical springs between the bolster and the car body. Several Japanese truck designs used in the U.S. have the Type 42 arrangement.
- *Type 43* trucks, shown in Figure 3.3c, have no bolster or center pivot, and the car body is carried directly on springs mounted on the truck frame. The secondary springs have enough lateral and longitudinal flexibility to accommodate truck lateral and yaw movements. The only U.S. application of Type 43 trucks is on some commuter cars on the Long Island Railroad. This truck arrangement is extensively used in Europe.



**Figure 3.2a**

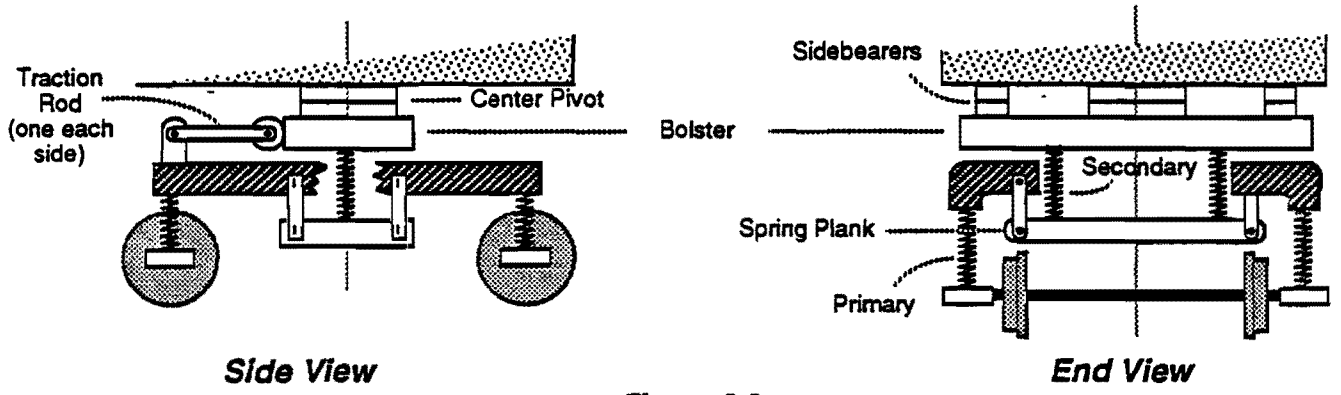
**Type 31: Rigid frame truck with equalizer beam and swinghanger secondary**



**Figure 3.2b**

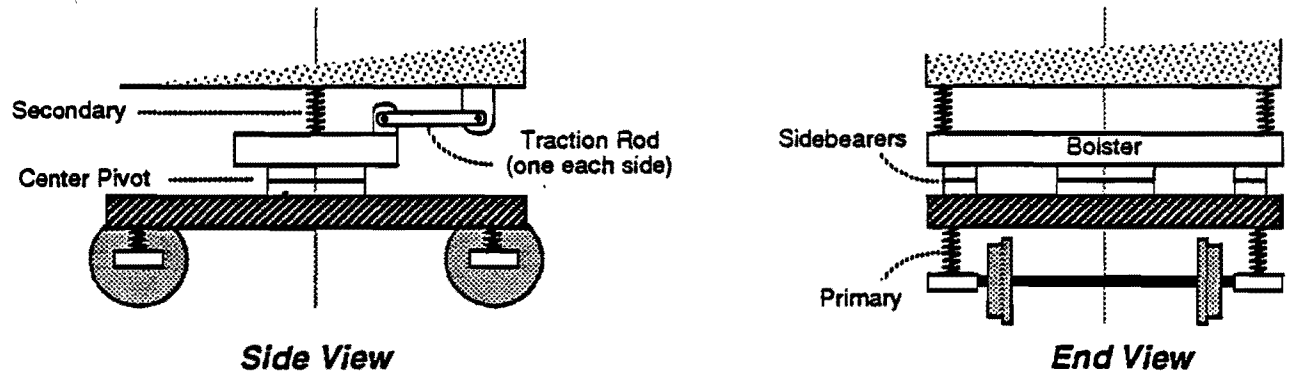
**Type 32: Rigid frame truck with equalizer beam and lower yaw pivot**

**Figure 3.2 Schematics of Truck Types 31 and 32**



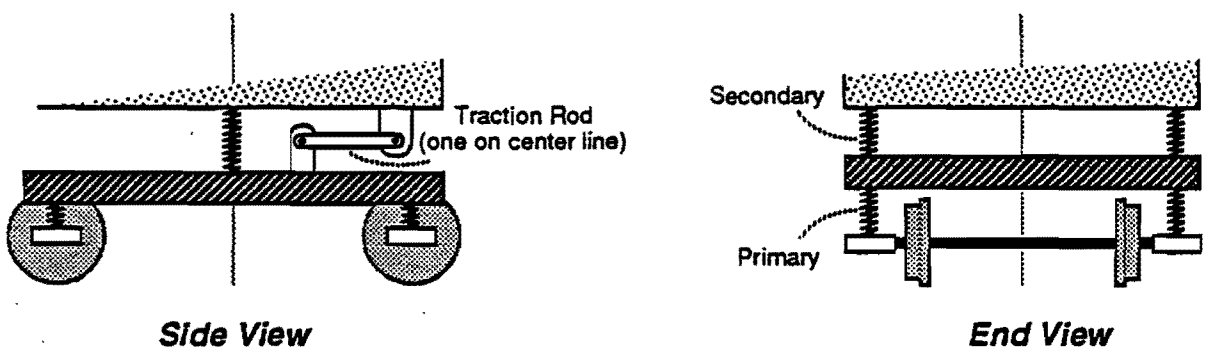
**Figure 3.3a**

Type 41: Rigid frame truck with journal springs and swinghanger secondary



**Figure 3.3b**

Type 42: Rigid frame truck with journal springs and lower yaw pivot



**Figure 3.3c**

Type 43: Rigid frame truck with journal springs and bolsterless secondary

**Figure 3.3 Schematics of Truck Types 41, 42, and 43**

The types of axle steering and car body tilt systems which could potentially be applied to passenger cars for operation in the U.S. are now described.

*Steering Systems* improve the ability of the axles of a truck to become aligned radially with respect to a curve, beyond that which occurs as a result of the interaction between wheel-to-rail forces and the primary yaw and lateral suspension. There are two kinds of steering:

- Type S<sub>1</sub>     Passive inter-axle linkages or other passive suspension elements permitting radial alignment of axles. Example: X 2000 trailer trucks.
- Type S<sub>2</sub>     Forced steering using linkages between axles, truck frame and car body to force the wheels to take up a correct yaw angle relative to the truck frame or car body. Examples: SIG Navigator and the Talgo intermediate articulation trucks.

*Car Body Tilt Systems* alleviate passenger discomfort when negotiating curves with high cant deficiency by tilting the car body inwards.

- Type T<sub>1</sub>     Passive tilt, with a secondary suspension or tilt center situated well above the car body center of gravity, allowing the body to swing outwards under centrifugal forces. Example: Talgo Pendular.
- Type T<sub>2</sub>     Active tilt, with the tilt mechanism typically situated between a tilting bolster and a bolster supported on the truck pivot, or between a bolster and the car body. Examples: ABB X 2000 trailer truck, the Italian Pendolino, and various Japanese systems.

### 3.3 TRUCK POPULATION DATA

The population of passenger car truck designs presently in operation in the U.S. is summarized in this section, using the detailed data provided in Appendix 2. Appendix 2 lists all car series' in operation in the U.S. by ownership and by truck classification as defined in Section 3.2 above. A car series is defined as a group of cars having the same body and truck design, of the same age, and, except in the case of some groups of older cars, manufactured by the same car builder. The data in the appendix reflects car fleets at approximately the beginning of 1994. The primary source of the data is the American Public Transit Association listing of railroad passenger cars for 1/1/94 [Reference 13].

About 92% of the 6392 cars identified in the listings are owned or operated by Amtrak and the six largest commuter rail systems, as shown in Table 3.2 in descending order of fleet size. Seven smaller commuter rail operators share the remaining 8%, making a total of 14 operators. Table 3.2 also lists the predominant car body and truck types used by each operator. The choice between bi-level and single-level car bodies is largely a function of railroad clearances. East coast operators with restricted clearances use single-level, whereas bi-level cars are used elsewhere. However, innovative bi-level designs have now been developed for eastern clearances and are being operated in the Boston area and on the Long Island Railroad. With regard to truck types, all the commuter operators have tended to limit their choices to one or two truck models over a long period. Amtrak, with a larger fleet and more varied operating conditions, uses a wider variety of truck models.

**Table 3.2 U.S. Rail Passenger Car Fleet by Operator**

Operator	Cars Owned			Principal Car and Truck Types
	Unpowered	Powered	Total	
National Railroad Passenger Corp. (Amtrak)	1668	18	1686	Bi-level (505) and single-level cars, various trucks
Long Island Railroad	199	832	1031	Single-level MU cars, Budd and GSI trucks
METRA (Chicago)	857	165	1022	Gallery bi-levels, some MU cars, GSI trucks
Metro-North Commuter Railroad	78	725	803	Single-level MU cars, GSI trucks
New Jersey Transit	366	300	666	Single-level MU and push-pull cars, GSI trucks
Massachusetts Bay Transportation Authority	346	-	346	Single-level push-pull cars, GSI trucks
Southeast Pennsylvania Transportation Authority	35	304	339	Single-level MU cars, GSI trucks
Maryland Department of Transportation (MARC)	119	-	119	Single-level push-pull cars, Nippon Sharyo trucks on newer cars
Southern California Regional Rail	106	-	106	Lozenge bi-level cars, Dofasco/Acheson trucks
Peninsular Service (San Francisco)	96	-	96	Bi-level cars of various types, GSI trucks
Virginia Rail Express (Washington DC Area)	59	-	59	Single-level push-pull cars, Nippon Sharyo trucks on newer cars
Northern Indiana Commuter Transportation District (Chicago South Shore)	-	58	58	Single-level MU cars, Nippon Sharyo trucks
California Department of Transportation	40	-	40	Amtrak-style bi-level cars, GSI trucks
Tri-county Commuter Rail Authority (South Florida)	21	-	21	Lozenge bi-level cars, Dofasco/Acheson trucks
<b>Total</b>	<b>3390</b>	<b>2402</b>	<b>6392</b>	

63

The car populations by truck classification and model are shown in Tables 3.3 and 3.4 for cars with unpowered and powered trucks, respectively. Among the unpowered cars, 80% of the fleet is equipped with just four truck models, all of U.S. manufacture: the Budd Pioneer, the traditional GSI swinghanger truck, and inboard and outboard bearing versions of the GSI G70 truck. Of these four models, only the two GSI G70 models are currently in production. The remaining 20% of the cars are equipped with seven different imported truck models from Europe and Japan. Furthermore, the most widely used imported model, the Dofasco truck, is now being manufactured in the U.S. by Atcheson Castings.

Truck models used on powered cars are even more concentrated, with 85% of the population of powered cars equipped with just two models; the Budd Pioneer (no longer in production) and the inboard bearing GSI G70. The remaining 15% are equipped with five different truck models, two of which are of U.S. manufacture (the traditional GSI swinghanger truck and the external bearing variant of the GSI G70), and the other three models, comprising only 5% of the fleet, are of European and Japanese manufacture.

Two factors have contributed to the concentration of trucks among so few models. Since about 1980 there has been only one domestic truck manufacturer in the U.S., producing the widely-used GSI G70 family. Also 'Buy America' legislation requires a specified minimum domestic content in passenger railcars which are purchased using Federal government funds, providing a strong incentive to use American-built trucks.

### **3.4 SUMMARY TRUCK DESCRIPTIONS AND DATA**

#### **3.4.1 Choice of Truck Designs for Detailed Descriptions**

Tables 3.3 and 3.4 indicate a total of 18 truck models in service in the U.S. Resources were not available to assemble detailed truck descriptions and data on all these models, so the approach taken was to assemble data on a sample of trucks representing major and distinctive designs in use or likely to be used in the U.S. The selected trucks, listed in Table 3.5, were chosen to cover a significant fraction of the cars in service, to include an example of most truck classifications that have been purchased in recent years, and to include trucks used in different kinds of service. The selected trucks are applied to a total of 57% of all cars in service. The rationale for the individual choices were as follows:

- The Budd Pioneer, because it is the only truck currently in regular high-speed service (200 km/h, 125 mph) in the Northeast Corridor.
- The unpowered and powered versions of the inboard bearing GSI G70 truck, because it is the most widely used truck for single-level commuter cars, and is of a notably simple and economical design.
- The outboard bearing version of the GSI G70 unpowered truck, because it has been purchased in significant numbers in recent years by Amtrak and California Department of Transportation for application to single and bi-level intercity cars.
- The MD 76, because it has the most extensive service experience on an intercity bi-level car.
- The two Japanese Type 42e trucks, because both are examples of a truck type that may be used more extensively in the future, and because one of the two had encountered some operational problems.
- The Comeng/Tokyu Car truck, because it is the only representative of a modern bolsterless truck design, a type that could be more extensively used in the future.



**Table 3.3 Car Population by Truck Classification and Model - Unpowered Cars**

Classification	Origin	Model	Number of Cars in Service	Typical Applications
21i	United States	Budd Pioneer III	684	Amtrak Amfleet and Capitoliner cars
31e		Traditional	1185	Pre 1970 cars: Amtrak Heritage, METRA, other commuter
32i		GSI G70 inboard bearing	750	Pullman/Bombardier single-level push-pull commuter cars
32e		GSI G70 outboard bearing	564	Amtrak Superliner II, Horizon, and bi-level commuter cars
42i	United States/Canada	Dofasco/Atcheson	300	'Lozenge' bi-level commuter cars in Miami and Southern California
41e	Germany	MD76	282	Amtrak Superliner I bi-level cars
43e	France	Creusot-Loire	27	Amtrak Turbo trailer cars
	Australia	Comeng/Tokyo Car	10	LIRR bi-level commuter cars
42e	Japan	Nippon Sharyo NT319	75	MARC push-pull commuter car
		Tokyu Car	38	VRE push-pull commuter car
		Kawasaki	75	MBTA bi-level push-pull commuter cars
<b>Total</b>			<b>3990</b>	

**Table 3.4 Car Population by Truck Classification and Model - Powered Cars**

<b>Classification</b>	<b>Origin</b>	<b>Model</b>	<b>Number of Cars in Service</b>	<b>Typical Applications</b>
21i - P <sub>2</sub>	United States	Budd Pioneer	836	Long Island and Metro-North MU commuter cars
31e - P <sub>2</sub>		GSI Traditional	61	Old Metro-North MU cars
32i - P <sub>2</sub>		GSI G70 inboard bearing	1210	SEPTA, NJT, LIRR, MNCR MU commuter cars
32e - P <sub>2</sub>		GSI G70 outboard bearing	165	METRA Chicago bi-level MU cars
42e - P <sub>2</sub>	Japan	Nippon Sharyo NP312	58	NICTD - South Shore single-level MU cars
42i - P <sub>2</sub>		Tokyu Car	54	Metro North M4 series MU cars
43e - P <sub>2</sub>	France	Creusot-Loire	18	Amtrak Turbo Power Car
<b>Total</b>			<b>2402</b>	

**Table 3.5 Truck and Car Combinations Selected for Detailed Study**

Classification	Origin	Model	Number of Cars in Service	Applications Studied
21i	United States	Budd Pioneer III (unpowered)	684	Amtrak Amfleet single-level intercity cars
32i		GSI G70 inboard bearing (unpowered)	750	MBTA/Bombardier single-level push-pull commuter car
32e		GSI G70 outboard bearing (unpowered)	564	Amtrak Superliner II bi-level, Horizon single-level intercity cars
32i - P <sub>2</sub>		GSI G70 inboard bearing (powered)	1210	LIRR MU car Single-level
41e	Germany	MD76	282	Amtrak Superliner I bi-level intercity car
42e	Japan	Nippon Sharyo NT 319	75	MARC Northeast Corridor commuter cars, Virginia Railway Express cars
		Kawasaki	75	MBTA bi-level cars
43e	Australia	Comeng/Tokyu car	10	LIRR unpowered bi-level cars
Total			3650	

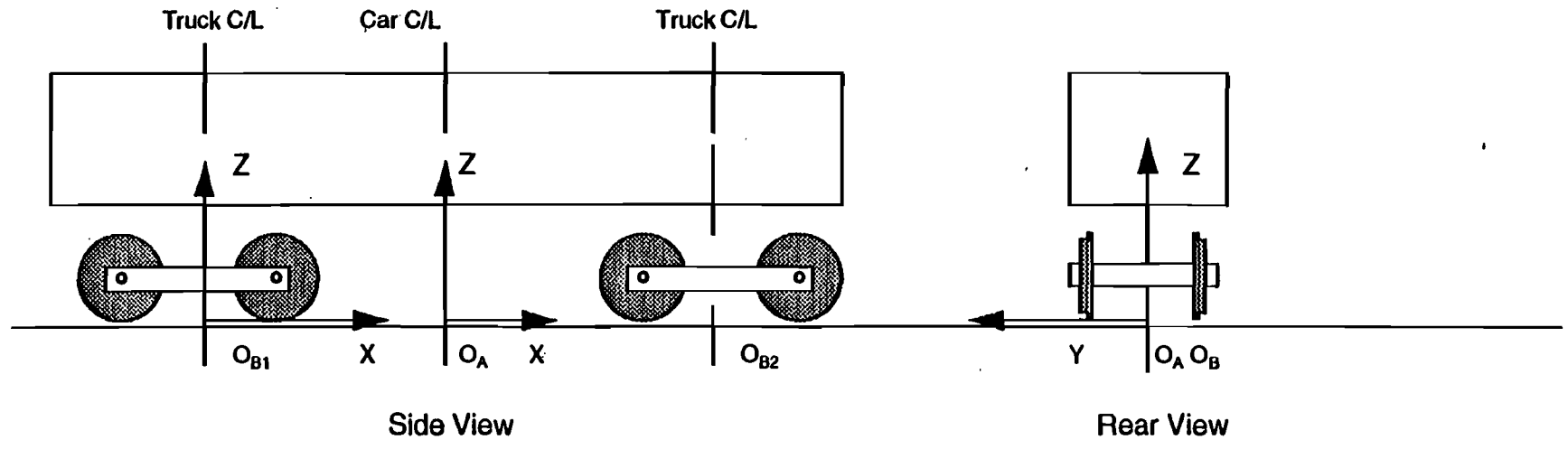
### 3.4.2 Methodology and Data Sources for Truck Data

The full data assembled on each truck are provided in Appendix 1. A variety of sources have been used to assemble the data, as follows:

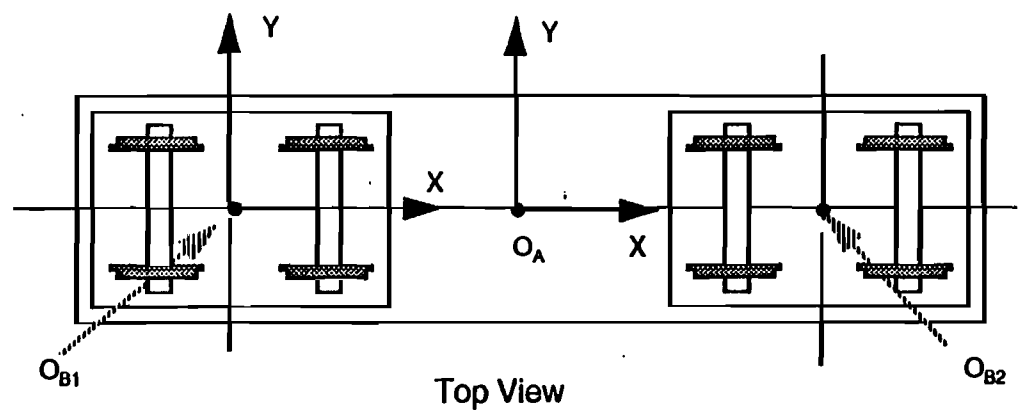
- *Data provided by the manufacturer.* Most manufacturers were willing to provide data on the truck layout, including assembly drawings, dimensions of the truck and components, and overall weights. However, manufacturers were not able to provide component mass and inertia, or any spring and damping rates. This information is regarded as proprietary, and could not be released for general publication. Such information is normally made available to the car purchaser, and any other person or organization performing truck analysis on behalf of the purchaser.
- *Prior technical reports and specifications.* Some truck data on the selected trucks has appeared in prior technical reports published by the Federal Railroad Administration and other agencies. Some data on the selected trucks has appeared in these reports, most notably References 2 and 3, and is repeated in this report. Reference 14 contains some data on service conditions on Amtrak lines relevant to trucks in Amtrak service. Finally specifications prepared by car purchasers for prospective car suppliers often contain relevant information about the expected operating environment.
- *Visits to operators.* Data on the operating environment for the trucks was generally obtained from the operator, supplemented by information in purchase specifications. In some cases it was also possible to see a disassembled truck and to take notes regarding truck mechanics and suspension components that could be used to estimate suspension characteristics.
- *Consultant estimates.* In some cases, it was possible for the consultant to make reasonable estimates of suspension parameters. This method was primarily used for estimates of the mass and inertia of suspension components. Given the overall mass of a truck, it is possible to develop a reasonable breakdown of the weight among the major components. The dimensional data typically available on general arrangement or assembly drawings can be used to estimate the location of the center of gravity and inertia about each axis.

In spite of the above efforts, it has not been possible to obtain or estimate a value for every parameter. Therefore some of the values in the tables in Appendix 1 are necessarily blank. Also it should be borne in mind that no parameter can be regarded as a fixed accurate value. All parameters are subject to variation, due to variability in the manufacturing process, inaccuracy in calculation (even when the calculations are done by a manufacturer in possession of fully detailed design data), and the wear and deterioration of components during use and over time. For example, the manufacturing process for molded rubber components is such that it is not possible to control stiffness to better than about + or - 10% when new, and rubber can creep and age over time, further altering stiffness and damping characteristics. Another factor is that operators may change suspension parameters over time, often in an effort to overcome a performance or durability problem, and these changes are not always well documented in terms of the effect on suspension parameters.

When detailing dimensions, stiffnesses, damping rates, and especially inertias, it is necessary to refer the data to a defined set of coordinates and an origin. The coordinates for rail passenger cars and trucks are given in Figure 3.4. The origin for both the car body and truck coordinates is located on the track centerline laterally and at the top of the rail vertically. The longitudinal origin for the car body is at the midpoint between the truck centers, and for a truck is at the midpoint between the outermost wheel sets. Roll, pitch and yaw are rotational movements about longitudinal, transverse and vertical axes respectively, passing through the origin.



3-15



Coordinate	Coordinate Origin	
	Truck	Car Body
Longitudinal, X	Half Truck Wheelbase	Half Truck Center Spacing
Lateral, Y	Track Center	Track Center
Vertical, Z	Top of Rail	Top of Rail

Figure 3.4 Coordinate System for Non-articulated Railroad Passenger Car with Two 2-axle Trucks



## APPENDIX 1

### DETAILED PASSENGER CAR TRUCK DATA AND DESCRIPTIONS

#### A1.0 INTRODUCTION

This appendix contains detailed descriptions and data for each of the eight selected truck designs. The specific information provided for each truck design is as follows:

##### A1.0.1 Truck Data

- A general narrative description of the truck design.
- An exploded engineering drawing of the truck showing the principal components, and a schematic showing the relationship between truck structural components and interconnecting elements such as springs and dampers.
- Basic truck dimensional and mass data.
- Detailed tabulations of truck mass, inertia, and suspension parameters
  - Centers of gravity, masses and moments of inertia of principal components
  - Primary suspension parameters
  - Secondary suspension parameters
- A narrative description of longitudinal, lateral and vertical load paths.

##### A1.0.2 Operating Environment and Operating Experience Data

- General information on passenger car series to which the truck is applied.
- Operating data and route data for typical routes over which the car is operated, such as speed, train length, frequency of stops, etc.
- Maintenance and service experience.

##### A1.0.3 Engineering Data on the Passenger Railroad Car and Car-Truck Interface

This section provides general information on the car to which the truck is applied (mass, etc.), and details of the car-truck interface.

The specific trucks for which this information has been prepared are given in the table below.

Section	Truck Classification	Truck & Classification(s)	Page
A1.1	2li	Budd Pioneer III truck for Amtrak Amfleet Car	A1.3
A1.2	32i	GSI-G70 truck for single-level commuter car	A1.16
A1.3	32i-P <sub>2</sub>	Powered GSI-G70 truck for LIRR M3 MU car	A1.29
A1.4	32e	Buckeye/GSI-G70 truck for Amtrak Superliner II bi-level car	A1.42
A1.5	41e	Waggon Union MD-76 truck for Amtrak Superliner I bi-level car	A1.55
A1.6	42e	Kawasaki truck for MBTA bi-level commuter car	A1.67
A1.7	42e	Nippon Sharyo truck for Marc II commuter car	A1.79
A1.8	43e	Comeng truck for LIRR bi-level commuter car	A1.92



## **A1.1: BUDD PIONEER III**

### **A1.1.1 Engineering Data**

#### **A1.1.1.1 Narrative Description of Truck Design**

**Truck Classification** 21i

**General Characteristics** For the Amtrak application under the Amfleet cars the Pioneer III is an unpowered version of the design that uses inboard journal bearings and a lower yaw pivot.

**Frame** The side frames are rectangular tubes. A triangular structure, integral with each side frame, is terminated in a half bearing at the central pivot that is attached to the bolster. This arrangement provides independent pitch motion of the two side frames in that the wheels can negotiate cross level irregularities with satisfactory load equalization. The frame assembly supports a bolster through the center pivot.

#### **Suspension System**

– **Primary** The primary springing is a unique arrangement that uses an unbonded rubber ring between the axle bearings and their housings. Dampers are not used. Rubber pads are also used between the truck side frames and the bolster side bearers. Both rubber sections also provide some degree of damping.

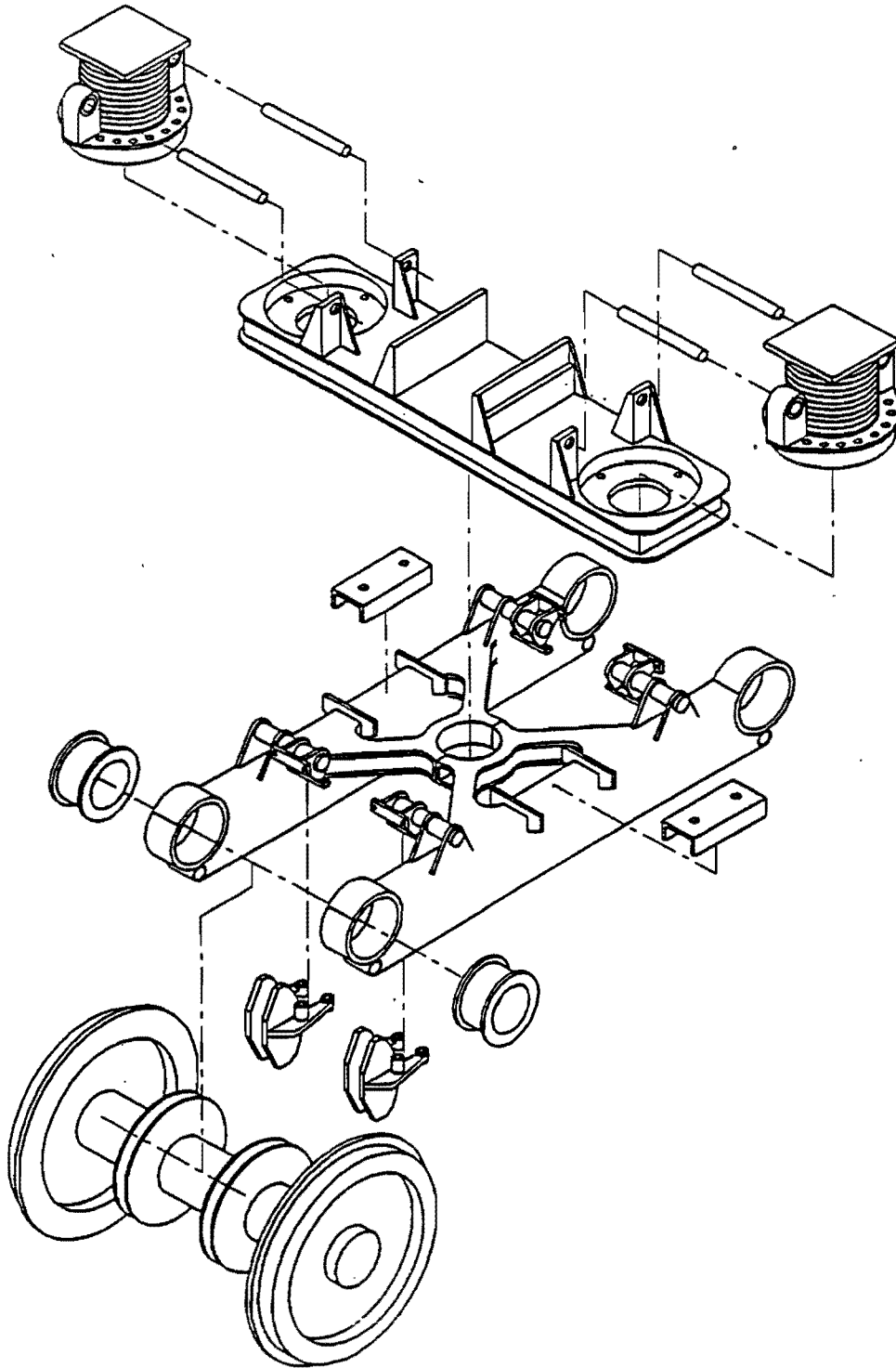
– **Secondary** The secondary suspension uses a series arrangement of coil and air springs. The wide spacing of the secondary springs provides roll stability that eliminates the need for a roll stabilizer. Hydraulic dampers are provided for vertical and lateral car body motion.

**Propulsion System** Not applicable.

**Braking System** Originally used only with disc brakes, two per axle. Later modified to also include tread brakes, forming a blended dual-brake system.

Exploded engineering and schematic drawings of this truck are provided in Figures A1.1.1 and A1.1.2

**A1.1: BUDD PIONEER III (continued)**



**Figure A1.1.1 Budd Pioneer III for Amtrak Cars - Exploded View**

A1.1: BUDD PIONEER III (continued)

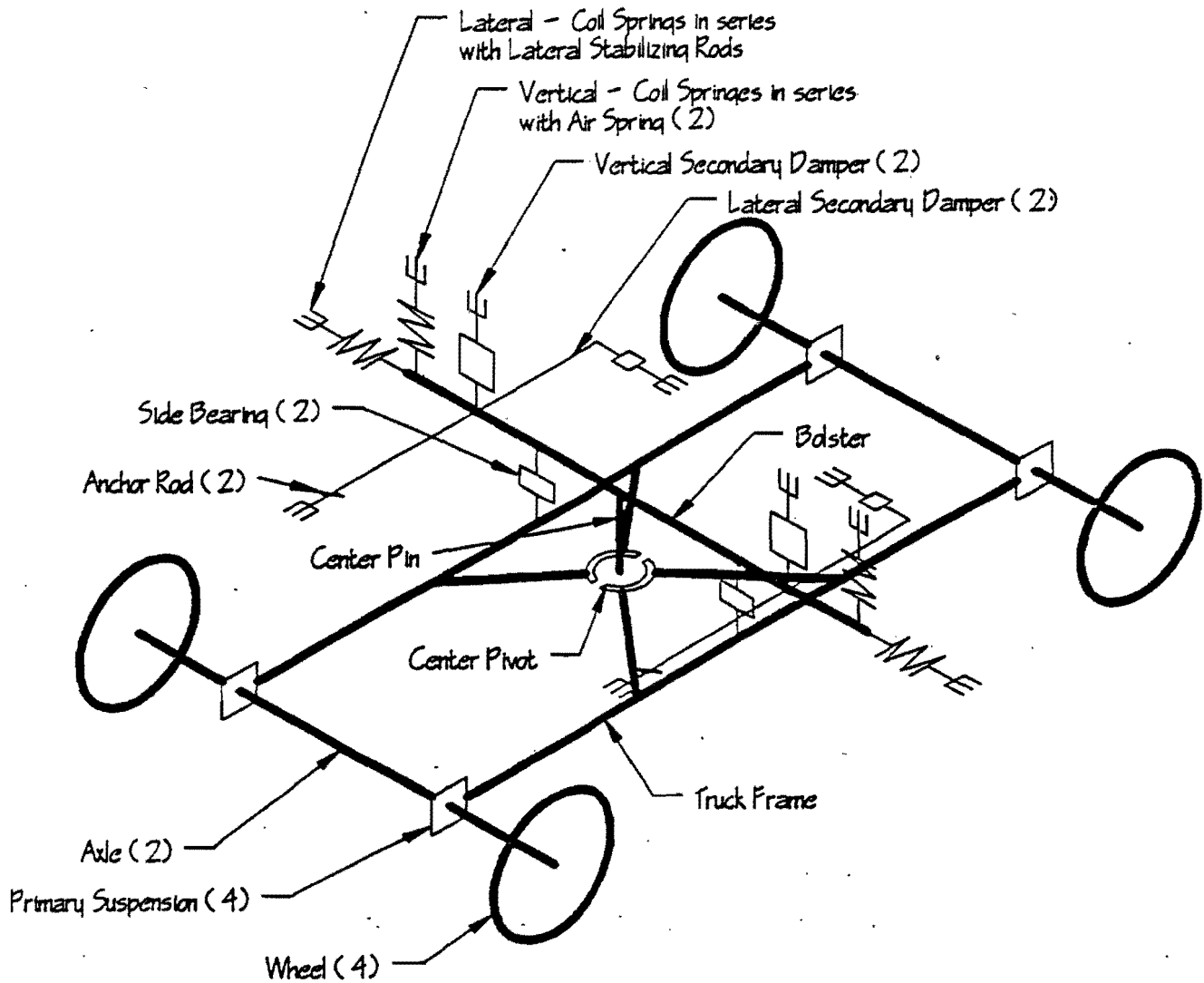


Figure A1.1.2 Budd Pioneer III for Amtrak Cars - Schematic

## **A1.1: BUDD PIONEER III (continued)**

### **A1.1.1.2 Basic Truck Data**

Track Gauge	1435 mm (56.5 in)
Wheel Base	2591 mm (102 in)
Wheel Diameter	914 mm (36 in)
Bolster Bowl Diameter	Not applicable
Truck Rotational Break Out Torque	10.17x10 <sup>6</sup> mm-N (0.9x10 <sup>5</sup> in-lb <sub>f</sub> )
Design Load (Top of Bolster Bowl)	198.2 kN (44700 lb <sub>f</sub> )
Total Truck Weight	60.97 kN (13700 lb <sub>f</sub> )
Brake Type	See Section A1.1.1.1
Motor	None
Gear Box	None

A1.1.1.3 Truck Center of Gravity, Mass and Moment of Inertia

Component Description	Number of Components	Mass of 1 Component kg (lb <sub>f</sub> ·sec <sup>2</sup> /in)	Center of Gravity Location mm (in)			Moment of Inertia kg·m <sup>2</sup> (lb <sub>f</sub> ·in·sec <sup>2</sup> )		
			X	Y	Z	I <sub>xx</sub>	I <sub>yy</sub> <sup>*</sup>	I <sub>zz</sub>
Wheel & Axle Set	2	1562.0 (8.9)	1297.5 (51.1)	0.0	457.2 (18)	657 (5.8)	---	657.0 (5.8)
Truck Frame	1	1716.9 (9.8)	0.0	0.0	472.4 (18.6)	11.0 (9.72)	4.05 (3.58)	16.1 (14.2)
Bolster	1	1384.0 (7.9)	0.0	0.0	668.0 (26.3)	***	***	***
Equalizer Bar	---	---	---	---	---	---	---	---
Motor	---	---	---	---	---	---	---	---
Gear Box	---	---	---	---	---	---	---	---
Tread Brake Unit	4	***	***	***	***	***	***	***
Primary Spring	---	---	---	---	---	---	---	---
Secondary Vertical Damper	2	***	***	***	***	***	***	***
Secondary Lateral Damper	2	***	***	***	***	***	***	***
Anchor Rod	2	***	***	***	***	***	***	***
Air Spring Assy.	2	***	***	***	***	***	***	***

--- Not applicable to this truck or value not relevant  
 \* Non-rotating component only for wheel and axle set  
 \*\*\* Value required, but not available or estimated

A1-7

A1.1: BUDD PIONEER III (continued)

**A1.1.1.4 Truck Suspension Parameters**

**A1.1.1.4.1 Primary Suspension**

Component	Stiffness N/mm (lb/in)			Damping Rates N sec/mm (lb <sub>f</sub> sec/in)			Clearance and Travel Tolerances mm (in)		
	Longi- tudinal	Lateral	Vertical	Longi- tudinal	Lateral	Vertical	Longi- tudinal	Lateral	Vertical
Individual Springs									
- Inside	---	---	---	---	---	---	---	---	---
- Outside	---	---	---	---	---	---	---	---	---
Double Coil Spring Set	---	---	---	---	---	---	---	---	---
Total/Wheel	180.4x10 <sup>3</sup> (1030x10 <sup>3</sup> )	28.2x10 <sup>3</sup> (161x10 <sup>3</sup> )	180.4x10 <sup>3</sup> (1030x10 <sup>3</sup> )	89.250	85-2125*	89-250*	***	***	***

\*Range, metric units (estimates)

--- Not applicable to this truck or value not relevant

\*\*\* Value required, but not available or estimated

**A1.1.1.4.2 Secondary Suspension**

Component	Stiffness N/mm(lb <sub>f</sub> /in.)			Damping Rates N sec/mm(lb <sub>f</sub> sec/in.)		
	Longitudinal	Lateral	Vertical	Longitudinal	Lateral	Vertical
Spring (per Truck)	---	728 (4000)	674 (3700)	---	---	---
Lateral Bumper (Bolster/Car)	***	***	***	---	---	---
Vertical Shock Absorber	---	---	---	---	---	44 (240)
Lateral Shock Absorber	---	---	---	---	37 (200)	---
Center Pivot	---	---	---	---	---	---
Anchor Assembly	4553 (25000)	---	---	14 (78)	---	---

Component	Clearance & Travel Tolerances mm (in.)			Torque or Friction Force		
	Longitudinal	Lateral	Vertical	Longitudinal	Lateral	Vertical
Spring	---	***	***	---	---	---
Lateral Bumper (Bolster/Car)	---	***	---	---	---	---
Vertical Shock Absorber	---	---	***	---	---	---
Lateral Shock Absorber	---	***	---	---	---	---
Center Pivot	---	---	---	Breakout friction torque about vertical axis 9.81 KN-m (0.9x10 <sup>5</sup> in.lbf)		
Anchor Assembly	***	---	---	---	---	---

--- Not applicable for this truck or value not relevant  
 \*\*\* Data required, but not available or estimated  
 Data taken from Reference 2.

61-9

A1.1: BUDD PIONEER III (continued)

## **A1.1: BUDD PIONEER III (continued)**

### **A1.1.1.5 Narrative Description of Load Path**

#### **A1.1.1.5.1 Longitudinal**

This load path, beginning at the car body, goes through outside anchor rods into the bolster, then into the interface between the bolster and the truck frame at the center pin. This force then continues through to the outside portion of the truck frame and then through the axle bearings.

#### **A1.1.1.5.2 Lateral**

This load path goes from the car body into the bolster through lateral coil springs that are in series with lateral stabilizing rods. The load path continues through the bolster center pin and on into the axle bearings.

#### **A1.1.1.5.3 Vertical**

This load path is from the car body, through the secondary suspension, into and along the bolster, into the frame through the side bearers and then into the axle bearing assembly of rubber rings and bearings.

#### **A1.1.1.6 Wheel Profile**

1/20 wheel conicity.



## **A1.1: BUDD PIONEER III (continued)**

### **A1.1.2 Operating Environment and Operating Experience Data**

#### **A1.1.2.1 Background Information/Car Series**

Operator	Amtrak
Type of Car	Corridor and long-haul intercity services
Name of Car Series	Amfleet I and II
Number in Service	622
Date(s) put into Service	1975/1979
Manufacturer of Car	Budd
Type of Truck (Volpe/ADL Designation)	21i
Truck Manufacturer and Model	Budd Company, Pioneer III

#### **A1.1.2.2 Operating and Route Data**

Amfleet I and II cars are primarily used in Amtrak's shorter-haul corridor intercity services, between cities 150 and 750 km (90-450 miles) apart. Most notably, Amfleet cars are the primary equipment used in conventional and high-speed Metroliner services between Washington, DC and Boston. Maximum speeds in Metroliner service are 200 km/h (125 mph).

Train Lengths Operated	Up to 12 cars
Braking Patterns (Friction/Dynamic)	Corridor type services with relatively frequent stops with typically 30 to 60 minutes between stations. Dynamic braking is used on electric and diesel-electric locomotives.



**A1.1: BUDD PIONEER III (continued)**

**A1.1.2.4 Maintenance and Service Experience**

Regular Servicing and  
Inspection Schedules

Major overhaul every three years. Routine servicing regularly for wheel turning, brake shoes, shims, etc.

Rationale for Maintenance  
Schedules

Experience has shown need for three year interval to prevent high failure rates.

Average or Typical Intervals  
(time or miles) Between  
Maintenance Action or  
Component Replacement

Three years or about 500,000 miles.

Information on Any Unusual  
Problems with Truck

Unusually high primary spring stiffness has created high force levels on truck components and on track structures.

Information on the  
Maintainability of  
the Truck

Truck maintenance is routine using normal procedures.

Information on the Operator's  
Experience  
with the Truck

Tests have shown high track forces with original primary spring design. Hot journal bearing detection continues to be a problem because of the inboard journal bearing design.

## **A1.1: BUDD PIONEER III (continued)**

### **A1.1.3 Engineering Data on Railroad Passenger Cars and Car-Truck Interface**

#### **A1.1.3.1 General Description of Car**

The Amfleet car is a single-level stainless steel car equipped for corridor intercity service. Various seating arrangements are used, and the fleet includes food service cars. Miscellaneous car equipment, such as braking and HVAC systems are mounted under the car floor. The cars were built in two series, between 1974-76, and 1980-81.

#### **A1.1.3.2 Car and Car Body Data**

##### **Overall Dimensions**

Length (over coupler faces)	26.00m (85.3 ft)
Width	3.20m (10.5 ft)
Height (from top of rail)	3.87m (12.7 ft)
Truck Center Spacing	18.13m (59.5 ft)
Car Weight	
- Ready to run	464 kN (104300 lbf)
- With maximum load	531 kN (119440 lbf)
Mass of Car Body (without trucks) (ready to run)	34890 kg (2389 lbf-sec <sup>2</sup> /ft)
Radius of gyration	
Roll	1.57m (5.2 ft)
Pitch	7.57m (24.8 ft)
Yaw	7.57m (24.8 ft)
Center of Gravity of Car Body (from top of rail)	1.91m (6.27 ft)
Car Body Natural Frequency (first vertical bending mode)	7.5 Hz

## **A1.1: BUDD PIONEER III (continued)**

### **A1.1.3.3 Car Body to Truck Interface**

The car body rests on two combination air and coil springs which rest on the truck bolster. Laterally spaced anchor rods provide the longitudinal connection between the bolster and the car body. Secondary lateral and vertical dampers are situated in parallel with the coil/air spring unit. Specific dimensions are as follows:

Vertical Spring Units (lateral spacing)	2.29m (7.5 ft)
Anchor Rods	
Lateral spacing	2.74m (9.0 ft)
Height above top of rail	0.51m (1.7 ft)

## **A1.2: GSI - G70 TRUCK**

### **A1.2.1 Engineering Data**

#### **A1.2.1.1 Narrative Description of Truck Design**

Truck Classification	32i
General Characteristics	This is an unpowered, inside frame truck, with a lower yaw pivot configuration. The truck is an equalizer beam design.
Frame	One piece cast steel pedestal H-type frame with or without end transoms. The frame supports a bolster on a 22-inch diameter central bearing which accommodates a 1-inch thick bearing wear plate and a vertical wear sleeve.
Suspension System	
- Primary	Two single bar type equalizer beams and four sets of double nested steel coil springs provide vertical and lateral stiffness. There is no vertical damping except axle box to pedestal friction.
- Secondary	An air spring assembly is mounted at each end of the bolster to support the car body. There are two lateral shock absorbers and two vertical shock absorbers, one of each on each side of the truck.
Propulsion & Braking System	No propulsion system. The truck is equipped with four WABCO type GO-5 tread brakes. The truck is also equipped with hand brake connection.

Exploded engineering and schematic drawings of this truck are provided in Figures A1.2.1 and A1.2.2.

A1.2: GSI - G70 TRUCK (continued)

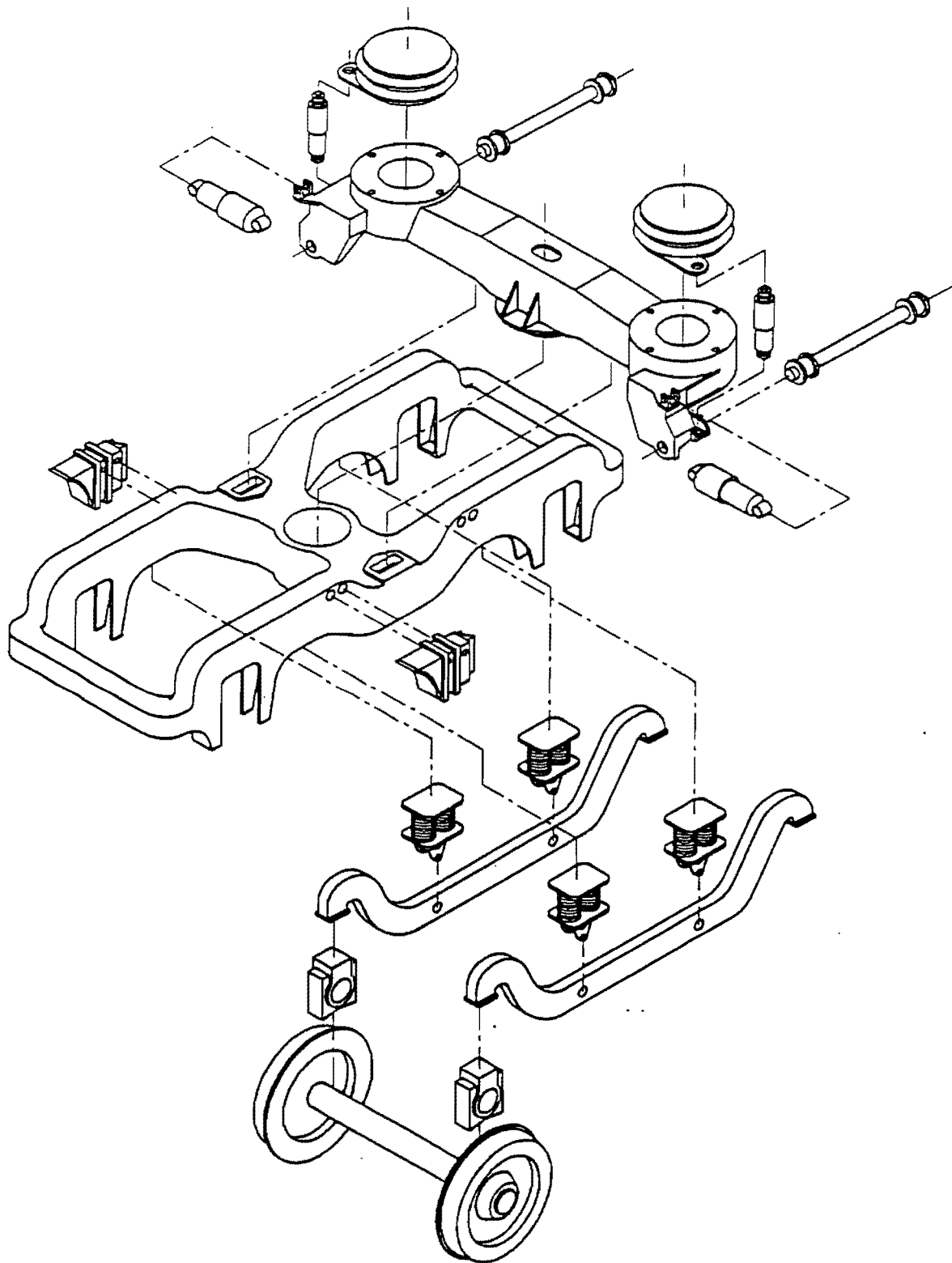


Figure A1.2.1 GSI Truck for MBTA Commuter Various Single-Level Cars - Exploded View

A1.2: GSI - G70 TRUCK (continued)

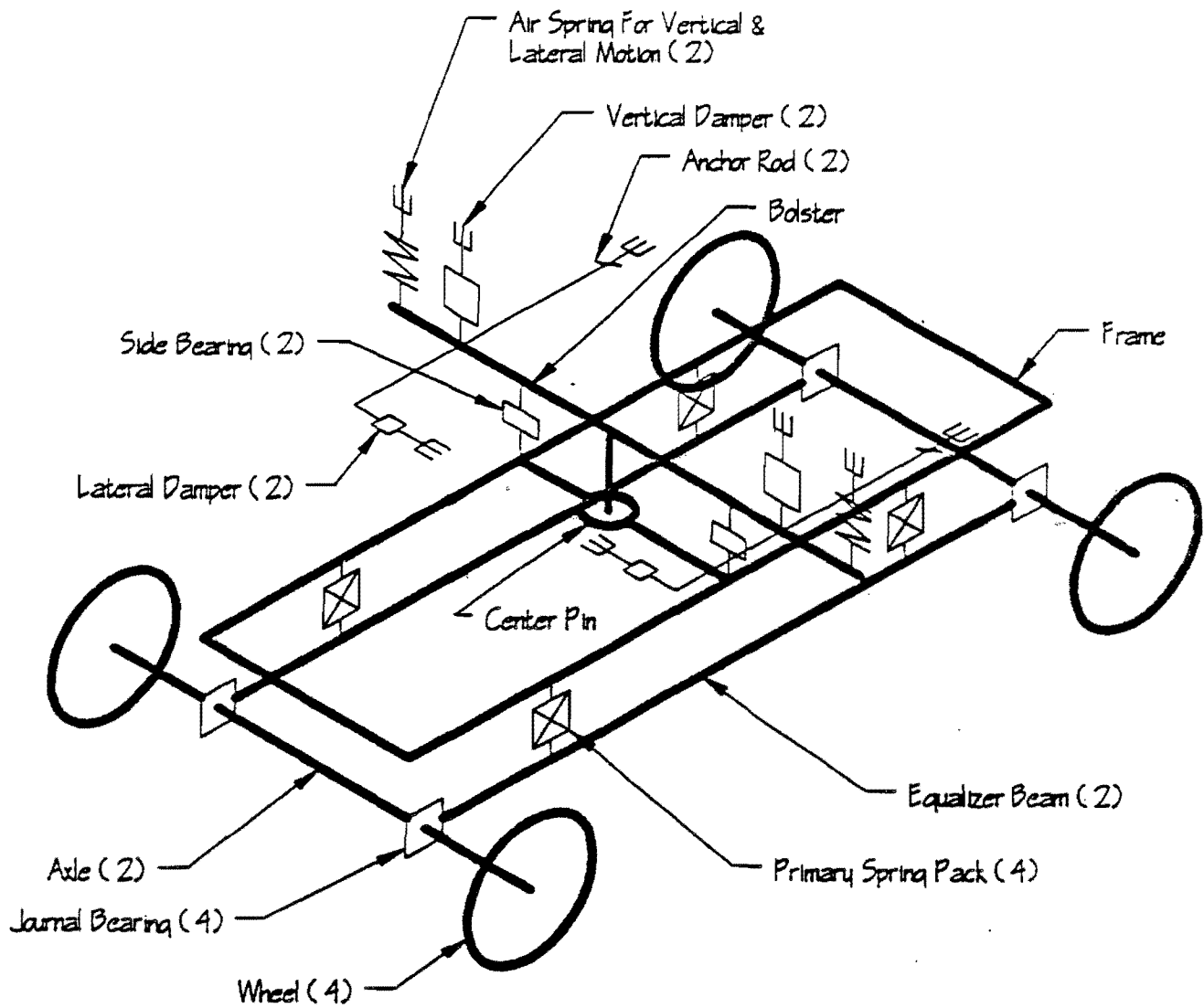


Figure A1.2.2 GSI Truck for MBTA Commuter Various Single-Level Cars - Schematic



## A1.2: GSI - G70 TRUCK (continued)

### A1.2.1.2 Basic Truck Data

Track Gauge	1435.1 mm (56.5 in)
Wheel Base	2590.8 mm (102 in)
Wheel Diameter	813.8 mm (32.0 in)
Bolster Bowl Diameter	558.8 mm (22.0 in)
Truck Rotational Break Out Torque	Not available
Design Load (Top of Bolster Bowl)	271.5 kN (61,000 lb <sub>f</sub> )
Total Truck Weight	53.4 kN (12,000 lb <sub>f</sub> )
Brake Type	WABCO GO-5 inch tread brake
Motor	N/A
Gear Box	N/A

### A1.2.1.3 Truck Center of Gravity, Mass and Moment of Inertia

Component Description	Number of Components	Mass of 1 Component kg (lb <sub>f</sub> -sec <sup>2</sup> /in)	Center of Gravity Location mm (in)			Moment of Inertia kg-m <sup>2</sup> (lb <sub>f</sub> -in-sec <sup>2</sup> )		
			X	Y	Z	I <sub>xx</sub>	I <sub>yy</sub> *	I <sub>zz</sub>
Wheel & Axle Set	2	1073 (5.84)	1295.4 (51.00)	0.0	406.4 (16.00)	492 (4342)	4 (31)	492 (4342)
Truck Frame	1	1219.3 (6.96)	0.00	0.0	575.3 (22.65)	3.28 (2899)	7.92 (7006)	11.0 (9758)
Bolster	1	602.7 (3.44)	0.00	0.0	762.0 (30.0)	3.34 (2954)	0.16 (137)	3.33 (2946)
Equalizer Bar	2	154.2 (0.88)	0.00	582.7 (22.94)	325.1 (12.80)	0.11 (94)	1.88 (1661)	1.77 (1567)
Motor	---	---	---	---	---	---	---	---
Gear Box	---	---	---	---	---	---	---	---
Tread Brake Unit	4	34.2 (0.20)	***	***	***	***	***	***
Primary Spring	4 sets	22.8 (0.13)	736.6 (29.00)	582.7 (22.94)	508.0 (20.00)	***	***	***
Secondary Vertical Damper	2	***	192.0 (7.56)	1428.8 (56.25)	480.1 (18.9)	***	***	***
Secondary Lateral Damper	2	***	393.7 (15.5)	1166.9 (45.94)	908.1 (35.75)	***	***	***
Anchor Rod	2	31.5 (0.18)	62.0 (2.44)	1352.6 (53.25)	482.6 (19.00)	***	***	***
Air Spring Assy.	2	49.1 (0.28)	0.00	1098.6 (43.25)	1062.0 (41.81)	***	***	***

--- Not applicable to this truck, or value not relevant

\* Non-rotating components only for wheel and axle set

\*\*\* Value required, but not available or estimated

**A1.2.1.4 Truck Suspension Parameters**

**A1.2.1.4.1 Primary Suspension**

Component	Stiffness N/mm (lb/in)			Damping Rates N sec/mm (lb <sub>f</sub> sec/in)			Clearance and Travel Tolerances mm (in)		
	Longitudinal	Lateral	Vertical	Longitudinal	Lateral	Vertical	Longitudinal	Lateral	Vertical
Individual Springs									
- Inside (3.375 in. O.D.)	70 (401)	70 (401)	70 (1147)	---	---	---	***	***	-79.0 (-3.11 (max))
- Outside (5.625 in. O.D.)	433 (2470)	433 (2470)	481 (2743)	---	---	---	***	***	-79.0 (-3.11 (max))
Double Coil Spring Set	1006 (5742)	1006 (5742)	1363 (7780)	---	---	---	---	---	---

--- Not applicable to this truck, or value not relevant

\*\*\* Value required but not available or estimated

**A1.2.1.4.2 Secondary Suspension**

Component	Stiffness N/mm(lb <sub>f</sub> /in.)			Damping Rates N sec/mm(lb <sub>f</sub> sec/in.)		
	Longitudinal	Lateral	Vertical	Longitudinal	Lateral	Vertical
Air Spring	*Firestone(#29-C)	***	***	---	---	---
Lateral Bumper (Bolster/Car)	---	***	---	---	---	---
Vertical Shock Absorber	---	---	---	---	---	*(Monroe 80131)
Lateral Shock Absorber	---	---	---	---	*(Monroe 70051)	---
Center Pivot	---	---	---	---	---	---
Anchor Assembly	***	---	---	---	---	---

Component	Clearance & Travel Tolerances mm(in.)			Torque or Friction Force		
	Longitudinal	Lateral	Vertical	Longitudinal	Lateral	Vertical
Air Spring	---	---	330.2 (13.0) (max)	---	---	---
Lateral Bumper (Bolster/Car)	---	3.175 (0.125) (free) 9.575 (0.375) (max)	---	---	---	---
Vertical Shock Absorber	---	---	***	---	---	---
Lateral Shock Absorber	---	***	---	---	---	---
Center Pivot	---	---	---	---	***	(about vertical axis)
Anchor Assembly	***	---	---	---	---	---

\*Manufacturer and part number

--- Not applicable to this truck or value not relevant

\*\*\* Value required, but not available or estimated

A1-22

A1.2: GSI - G70 TRUCK (continued)

## **A1.2: GSI - G70 TRUCK (continued)**

### **A1.2.1.5 Narrative Description of Load Path**

#### **A1.2.1.5.1 Longitudinal**

The path of a longitudinal load travels through the wheel to the truck frame. The load goes through the center pivot to the bolster. From the bolster it goes through the anchor rods to the car body. When the brakes are applied the load produced is reacted at the pedestal guides.

#### **A1.2.1.5.2 Lateral**

A lateral load goes through the wheel to the truck frame through the center pivot to the bolster. From the bolster it travels through the rubber bump stops to the car body.

#### **A1.2.1.5.3 Vertical**

The path of a vertical load travels from the wheel to the equalizer beam to the primary springs to the truck frame. From the frame it goes through the center pivot to the bolster through the air spring to the car body.



## A1.2: GSI - G70 TRUCK (continued)

Train Lengths Operated	5-9 cars
Braking Patterns (Friction/Dynamic)	Policy is to use dynamic brake. Eighteen of 55 locomotives not equipped with dynamic brake. Policy is to run with EP brake cut out: Bombardier 350 series do not have EP brake.

### A1.2.2.3 Track System Data

#### FRA Track Class

- Main  
The MBTA attempts to maintain its track at class 4-5 with 5% above class 6 (Northeast Corridor segment).
- Sidings and Yard  
90% exceeds class 3, and 10% borderline class 1.

#### Approximate Percentage of Welded & Jointed Rail

Approximately 40% welded rail.

#### Rail-Tie Fastener System

Conventional cut-spike on wood tie. Pandrol clips on concrete ties on Northeast Corridor.

#### Curvature Data

- Average/Typical Curvature on Main Track  
3-4°
- Maximum Curvature on Track  
13° 30' max. curve on main line.
- Approximate Percentage of Curved /and Tangent Main Track  
No definitive information. Track dept. estimates 20%.
- Typical Spiral Length Relative to AREA Recommendations  
Not available
- Typical Curvature in Yard and Siding Tracks  
10-12°
- Maximum Curve Radius in Yards and Sidings  
32° max. curve in Boston Engine Terminal yard.

## **A1.2: GSI - G70 TRUCK (continued)**

### **- Typical Turnout Size (AREA Number)**

Main line	Generally minimum No. 10 with some exceptions at No. 8.
Yard	No. 8 with a couple of exceptions at No. 6.

### **A1.2.2.4 Maintenance and Service Experience**

Regular Servicing and Inspection Schedules	Cab or inspection every 3 months (92 days) by law. Blind traveler car (without cab) inspected every 180 days. Trucks generally inspected for wheels, brakes, springs and wear plates and structural integrity. Air brake inspection mandated every 3 years.
Rationale for Maintenance Schedules	Major truck overhaul is scheduled every 6 years (this is based on Amtrak experience). Attempt is to refurbish to new condition. Springs and liners, wheelsets and wear plates (pedestal) are replaced with new.
Average or Typical Intervals (time or miles) between Maintenance Action or Component Replacement	Other than above scheduled maintenance, components are replaced on a failure basis, e.g., broken equalizer springs and ruptured air bags (neither have been a problem). Wheel reprofiling and side bearing replacement as required.
Information on any Unusual Problems with Truck	Three incidents of cracked equalizer bars on MBB cars which resulted from a bad welding practice. One other cracked equalizer - cause not known. Isolated broken primary springs. Essentially, no unusual problems on this truck.
Information on the Maintainability of the Truck	This truck is simple and relatively easy to maintain. Brakes and other components are accessible. Maintenance supervisor reports good experience with this truck.
Information on the Operator's Experience with the Truck	Used since 1979 with no problems. Wheel damage has been a problem, but this was a result of operating without the wheel slide system. This situation has been rectified (100% operative wheel slide systems) and is no longer an acute problem.



## A1.2: GSI - G70 TRUCK (continued)

### A1.2.3 Engineering Data on Passenger Railroad Cars and Car-Truck Interface

#### A1.2.3.1 General Description of Car

The car is a single-level commuter coach car manufactured by Bombardier. The car design originated with Pullman Standard in the early 1970s and was later acquired by Bombardier. Approximately 30% of the cars are equipped with a control cab for push-pull operations. The car body is of welded aluminum construction, mounted on a steel underframe. Miscellaneous car equipment (HVAC systems, brake systems, etc.) are mounted under the floor between the trucks. As well as the MBTA application, a large number of similar cars are in service with other east coast commuter agencies, including Metro North, New Jersey Transit, and SEPTA.

#### A1.2.3.2 Car and Car Body Data

##### Overall Dimensions

Length (over coupler faces)	26.00m (85.3 ft)
Width	3.20m (10.5 ft)
Height (from top of rail)	3.89m (12.7 ft)

Truck Center Spacing	18.14m (59.5 ft)
----------------------	------------------

##### Car Weight

- Ready to run	
Trailer cars	397 kN (89,000 lbf)
Cab cars	424 kN (95,000 lbf)
- With maximum load	
Trailer cars	478 kN (107,300 lbf)
Cab cars	505 kN (113,300 lbf)

##### Mass of Car Body (without trucks)

- Ready to run	
Trailer cars	29562 kg (2019 lbf-sec <sup>2</sup> /ft)
Cab cars	32314 kg (2205 lbf-sec <sup>2</sup> /ft)

##### Radius of gyration

Roll	1.58m (5.2 ft) (est)
Pitch	7.57m (24.8 ft)
Yaw	7.57m (24.8 ft)

Center of Gravity of Car Body (from top of rail)	1.52m (5.6 ft) (est)
---	----------------------

Car Body Natural Frequency (first vertical bending mode)	6-6.5 Hz (est)
---	----------------

## **A1.2: GSI - G70 TRUCK (continued)**

### **A1.2.3.3 Car Body to Truck Interface**

The car body rests on two Firestone air springs at each truck, situated at the outer end of the bolster. The longitudinal connection between the trucks and the car body is via two laterally spaced longitudinal anchor rods between the car body and the truck bolster. Secondary vertical and lateral dampers (two of each) are also provided between the bolster and body.

Specific dimensions are as follows:

Lateral Spacing of Airsprings	2.19m (7.2 ft )
Lateral spacing of secondary vertical dampers	2.86m (9.4 ft)
Lateral spacing of anchor rods	2.70m (8.9 ft)
Height of anchor rods above top of rail	0.48m (1.6 ft)

## **A1.3: POWERED GSI-G70 TRUCK FOR LIRR M3 MU CAR**

### **A1.3.1 Engineering Data**

#### **A1.3.1.1 Narrative Description of Truck Design**

Truck Classification	32i - P <sub>2</sub>
General Characteristics	This cast steel truck is fully equalized, with inboard journal bearings, a bolster, and traction rods connected to the car body. It is a motorized design.
Frame	The cast steel H frame uses pedestal guides to control axle position and has two side bearings.
Suspension System	
- Primary	Two separate multi-coil steel spring packs are used with each of the two equalizer beams. Primary dampers are not used.
- Secondary	Two air springs are used between the truck bolster and the car body. Vertical and lateral shock absorbers are used for damping to supplement the air spring orifice system.
Propulsion & Braking System	Each axle is driven by a D.C. traction motor that is controlled by a resistance - cam controller system. The motor also provides dynamic braking that is blended with the friction braking. Friction braking is provided by a tread brake unit at each wheel.

Exploded engineering and schematic drawings of this truck are provided in Figures A1.3.1 and A1.3.2.

A1.3: POWERED GSI-G70 TRUCK FOR LIRR M3 MU CAR (continued)

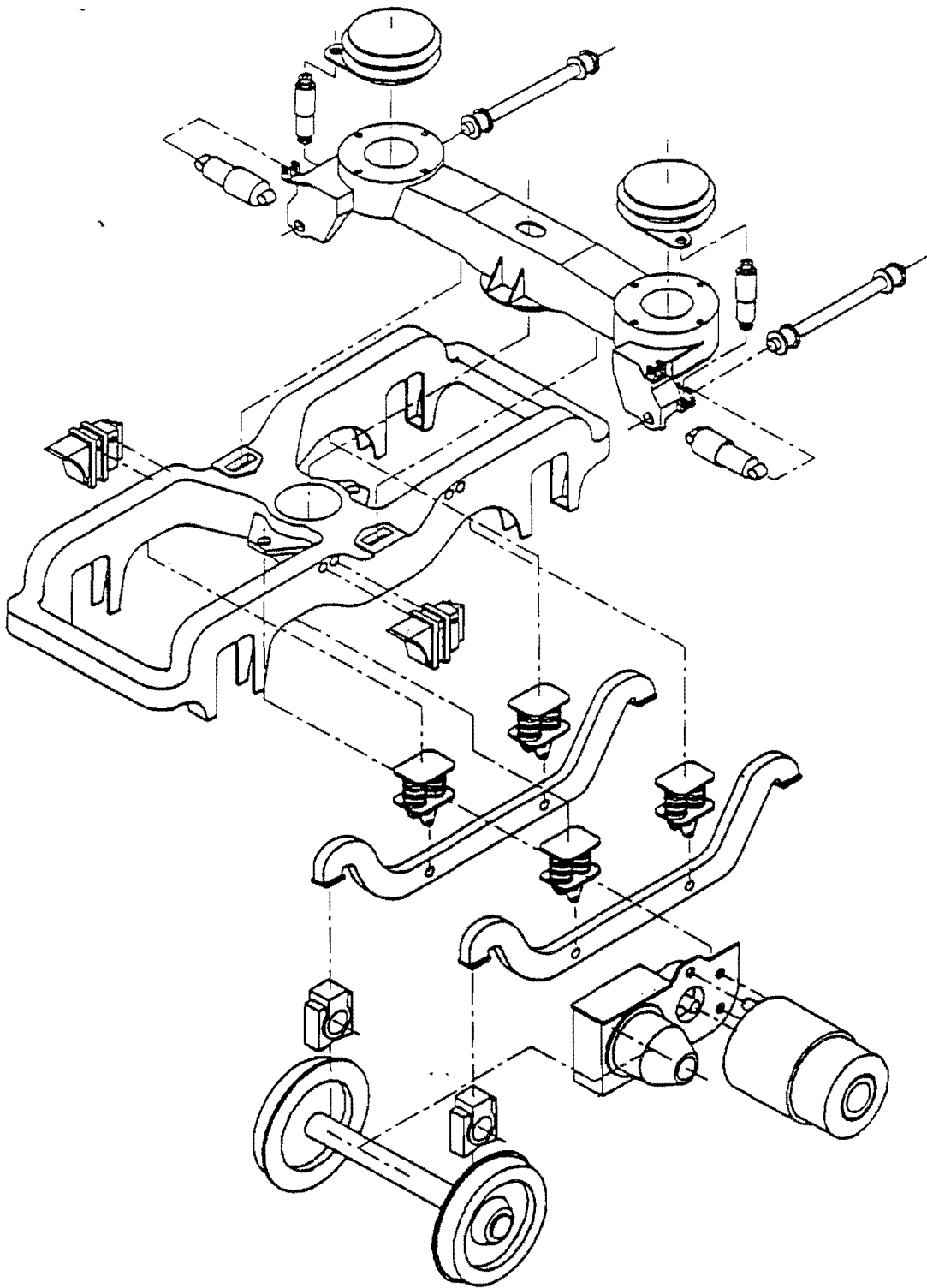


Figure A1.3.1 GSI Truck for Budd M3 for Long Island RR - Exploded View

A1.3: POWERED GSI-G70 TRUCK FOR LIRR M3 MU CAR (continued)

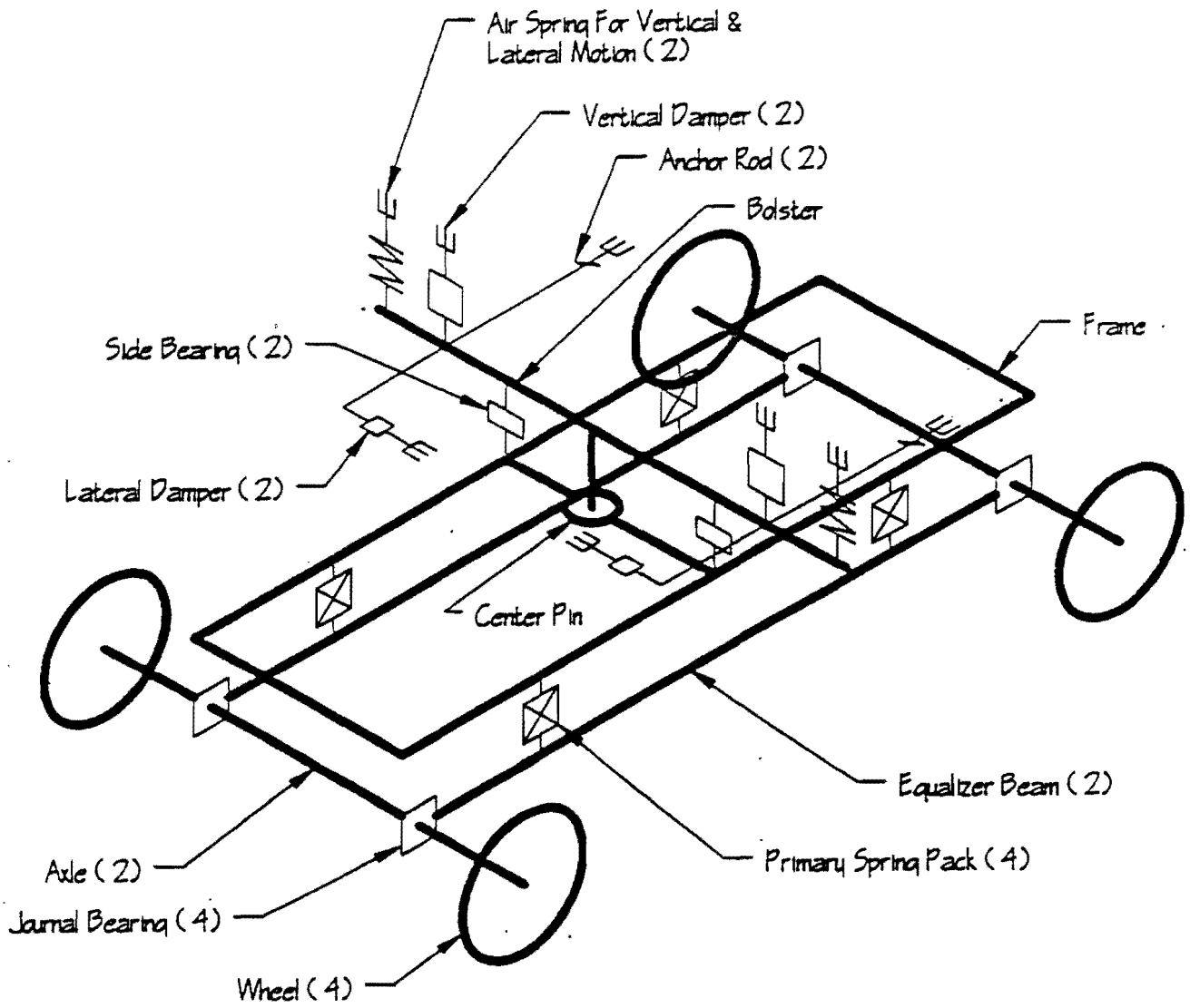


Figure A1.3.2 GSI Truck for Budd M3 for Long Island RR - Schematic

### **A1.3: POWERED GSI-G70 TRUCK FOR LIRR M3 MU CAR (continued)**

#### **A1.3.1.2 Basic Truck Data**

Track Gauge	1435 mm (56.5 in)
Wheel Base	2591 mm (102 in)
Wheel Diameter	813 mm (32 in)
Bolster Bowl Diameter	559 mm (22 in)
Truck Rotational Break-Out Torque	Not available
Design Load (Top of Bolster Bowl)	Not available
Total Truck Weight	80.1 kN (18000 lb <sub>f</sub> )
Brake Type	WABCO 26C-CS2 -Disc SAB - Tread brake
Motor	GE 1261B1 (DC 4 pole)
Gear Box	GA 56F3 Double Reduction Parallel Drive

**Gear box supported on one end by direct connection to the axle and on the other end by a cushioned link to the truck frame. The traction motor is resiliently supported on the coupling end to the gear box. The motor frame is supported by trunnions to the gear case and by cushioned rods to the gear case housing.**

### A1.3.1.3 Truck Center of Gravity, Mass and Moment of Inertia

Component Description	Number of Components	Mass of 1 Component kg (lb <sub>f</sub> sec <sup>2</sup> /in)	Center of Gravity Location mm (in)			Moment of Inertia kg-m <sup>2</sup> (lb <sub>f</sub> in-sec <sup>2</sup> )		
			X	Y	Z	I <sub>xx</sub>	I <sub>yy</sub> *	I <sub>zz</sub>
Wheel & Axle Set	2	1252 (12.7)	1295.4 (±51.00)	0.0	406.4 (16.0)	504 (4448)	61 (537)	504 (4448)
Truck Frame	1	1270 (7.25)	0.0	0.0	649.7(25.58)	5.0 (4440)	17.1 (15138)	21.5 (18976)
Bolster	1	862 (4.92)	0.0	0.0	711.2 (28.0)	6.4 (5636)	0.36 (320)	6.6 (5824)
Equalizer Bar	2	195.5 (1.11)	0.0	582.7(±22.94)	365.8 (14.4)	0.09 (77)	1.6 (1419)	1.5 (1343)
Motor	2	635 (3.63)	807.7 (±31.8)	0.0	440.7 (17.35)	***	***	***
Gear Box	2	454 (2.59)	1295.4 (±51.0)	121.9 (±4.8)	406.4 (16.0)	***	***	***
Tread Brake Unit	4	62.3 (0.36)	***	***	***	***	***	***
Primary Spring	4 sets	22.8 (0.13)	723.9 (±28.5)	582.7 (±22,94)	487.7 (19.2)	***	***	***
Secondary Vertical Damper	2	45.5 (0.26)	***	***	***	***	***	***
Secondary Lateral Damper	2	45.5 (0.26)	***	***	***	***	***	***
Anchor Rod	2	34 (0.20)	***	***	***	***	***	***
Air Spring Assy.	2	105 (0.6)	0.0	1016.0 (±40.0)	990.6 (39.0)	***	***	***

--- Not applicable to this truck, or value not estimated

\* Non-rotating components only for wheel and axle set

\*\*\* Value required, but not available or estimated

**A1.3.1.4 Truck Suspension Parameters**

**A1.3.1.4.1 Primary Suspension**

Component	Stiffness N/mm (lb/in)			Damping Rates N sec/mm (lb <sub>f</sub> sec/in)			Clearance and Travel Tolerances mm (in)		
	Longi- tudinal	Lateral	Vertical	Longi- tudinal	Lateral	Vertical	Longi- tudinal	Lateral	Vertical
Individual Springs									
- Inside	---	---	---	---	---	---	---	---	---
- Outside	---	---	---	---	---	---	---	---	---
Double Coil Spring Set	***	***	5290	---	---	---	***	***	***

--- Not applicable to this truck, or value not relevant

\*\*\* Value required, but not available or estimated



### A1.3.1.4.2 Secondary Suspension

Component	Stiffness N/inm(lb <sub>f</sub> /in.)			Damping Rates N sec/mmi(lb <sub>f</sub> sec/in.)		
	Longitudinal	Lateral	Vertical	Longitudinal	Lateral	Vertical
Air Spring	---	---	540.5 (3085) Loaded 356.3 (2033) Empty	---	---	---
Lateral Bumper (Bolster/Car)	---	***	---	---	---	---
Vertical Shock Absorber	---	---	---	---	---	*Monroe 80141 ***
Lateral Shock Absorber	---	---	---	---	*Monroe 70073 ***	---
Center Pivot	---	---	---	---	---	---
Anchor Assembly	***	---	---	---	---	---

Component	Clearance & Travel Tolerances mm(in.)			Torque or Friction Force		
	Longitudinal	Lateral	Vertical	Longitudinal	Lateral	Vertical
Spring Side Bearing	---	4.76 (3/16)	---	---	---	---
Lateral Bumper (Bolster/Car)	---	***	---	---	---	---
Vertical Shock Absorber	---	---	***	---	---	---
Lateral Shock Absorber	3.175(±1/8) ---	---	---	---	---	---
Center Pivot	---	---	---	*** (Torque about vertical axis)		
Anchor Assembly	***	---	---	---	---	---

\*Manufacturer and part number

--- Not applicable to this truck, or value not relevant

\*\*\* Value required, but data not available or estimated

A1-35

A1.3: POWERED GSI-G70 TRUCK FOR LIRR M3 MU CAR (continued)

## **A1.3: POWERED GSI-670 TRUCK FOR LIRR M3 MU CAR (continued)**

### **A1.3.1.5 Narrative Description of Load Path**

#### **A1.3.1.5.1 Longitudinal**

This load path beginning at the car body goes through the traction rods at each side of the car, then to the truck bolster, through the bolster to its center pin, then to the frame, then to the pedestal liners to the journal bearing housings.

#### **A1.3.1.5.2 Lateral**

The lateral load passes from the car body to the air springs, to the truck bolster, to the center pin, to the truck frame, to the equalizer springs to the equalizer beam, to the journal bearing housings. If motion is excessive, stops between the car body and the truck bolster engage.

#### **A1.3.1.5.3 Vertical**

The vertical load passes from the car body to the secondary air springs, to the truck bolster, through this bolster to the frame center pin to the equalizer spring packs, to the equalizer beams, to the top of the journal bearing housings.

#### **A1.3.1.6 Wheel Profile Drawing**

AAR B-32.

### **A1.3: POWERED GSI-G70 TRUCK FOR LIRR M3 MU CAR (continued)**

#### **A1.3.2 Operating Environment and Operating Experience Data**

##### **A1.3.2.1 Background Information/Car Series**

Operator	Long Island RR
Type of Car	Commuter, EMU
Name of Car Series	M3
Number in Service	174
Date(s) put into Service	1985
Manufacturer of Car	BUDD
Type of Truck (Volpe/ADL Designation)	32i - P <sub>2</sub>
Truck Manufacture and Model	GSI G70 GSI Drawing 35765

##### **A1.3.2.2 Operating and Route Data**

These cars are operated on the electrified portion of the Long Island Railroad in short and medium-distance commuter service (30-60 miles total journey length) between New York City and points on Long Island. Speeds are typically up to 127 km/h (79 mph) with occasional operation up to 160 km/h (100 mph). Very similar cars are operated in similar service by Metro-North Commuter Railroad, New Jersey Transit and Southeast Pennsylvania Transportation Authority.

Train Lengths Operated	Up to 10 cars
Braking Patterns (Friction/Dynamic)	Typical of short and medium-distance commuter operations with stops at 3-10 mile intervals.

## **A1.3: POWERED GSI-G70 TRUCK FOR LIRR M3 MU CAR (continued)**

### **A1.3.2.3 Track System Data**

FRA Track Class

LIRR Electrified System: no other information available

- Main
- Sidings and Yard

Approximate Percentage of  
Welded & Jointed Rail

Rail-Tie Fastener System

Curvature Data

- Average/Typical  
Curvature on Main  
Track
- Maximum Curvature on  
Track
- Approximate Percentage  
of Curved and Tangent  
Main Track
- Typical Spiral Length  
Relative to AREA  
Recommendations
- Typical Curve Radius  
in Yard and Siding  
Tracks
- Minimum Curve Radius  
in Yards and Sidings
- Typical Turnout Size  
(Area Number)  
Main line  
Yard

**A1.3: POWERED GSI-G70 TRUCK FOR LIRR M3 MU CAR (continued)**

**A1.3.2.4 Maintenance and Service Experience**

Regular Servicing and Inspection  
Schedules

No information available.

Rationale for Maintenance Schedules

Average or Typical Intervals  
(time or miles) between Maintenance  
Action or Component Replacement

Information on any Unusual  
Problems with Truck

Information on the Maintainability  
of the Truck

Information on the Operator's  
Experience with the Truck

## **A1.3: POWERED GSI-G70 TRUCK FOR LIRR M3 MU CAR (continued)**

### **A1.3.3 Engineering Data on Railroad Passenger Cars and Car-Truck Interface**

#### **A1.3.3.1 General Description of Car**

The car is a single-level electrically-powered commuter multiple unit car, using a third rail DC power supply. The car body is welded stainless steel. Miscellaneous car equipment including electric traction controls, HVAC equipment and brake equipment are mounted under the car floor. In addition to the Long Island application, similar MU cars using the same truck are operated by other northeastern U.S. commuter railroads.

#### **A1.3.3.2 Car and Car Body Data**

##### **Overall Dimensions**

Length (over coupler faces)	25.9 m (85 ft)
Width	3.25 m (10.7 ft)
Height (from top of rail)	3.95 m (12.9 ft)
Truck Center Spacing	18.14 m (59.5 ft)
Car Weight	
- Ready to Run	500 kN (112400 lb <sub>f</sub> )
- With Maximum Load	580 kN (131000 lb <sub>f</sub> )
Mass of Car Body (without trucks) (ready to run)	36440 kg (3273 lb <sub>f</sub> -sec <sup>2</sup> /ft)
Radius of Gyration	
Roll	1.55 m (5.1 ft) (Est)
Pitch	7.50 m (24.6 ft) (Est)
Yaw	7.50 m (24.6 ft) (Est)
Center of Gravity of Car Body (from top of rail)	1.50 m (4.9 ft) (Est)
Car Body Natural Frequency (first vertical bending mode)	6-6.5 Hz (Est)

## **A1.3: POWERED GSI-G70 TRUCK FOR LIRR M3 MU CAR (continued)**

### **A1.3.3.3 Car Body to Truck Interface**

The car body rests on two airsprings per truck, situated at the outer ends of the truck bolster. The longitudinal connection between the truck and the car body is provided by laterally spaced longitudinal anchor rods between the car body and the truck bolster. Two lateral and two vertical dampers also connect the truck bolster to the car body.

Specific dimensions are as follows:

Lateral spacing of airsprings	2.03 m (6.7 ft)
Lateral spacing of secondary vertical dampers	2.88 m (9.5 ft)
Lateral spacing of anchor rods	2.81 m (9.3 ft)
Height of anchor rods above top of rail	0.50 m (1.6 ft)

## **A1.4: BUCKEYE/GSI-G70 FOR AMTRAK SUPERLINER II BI-LEVEL CAR**

### **A1.4.1 Engineering Data**

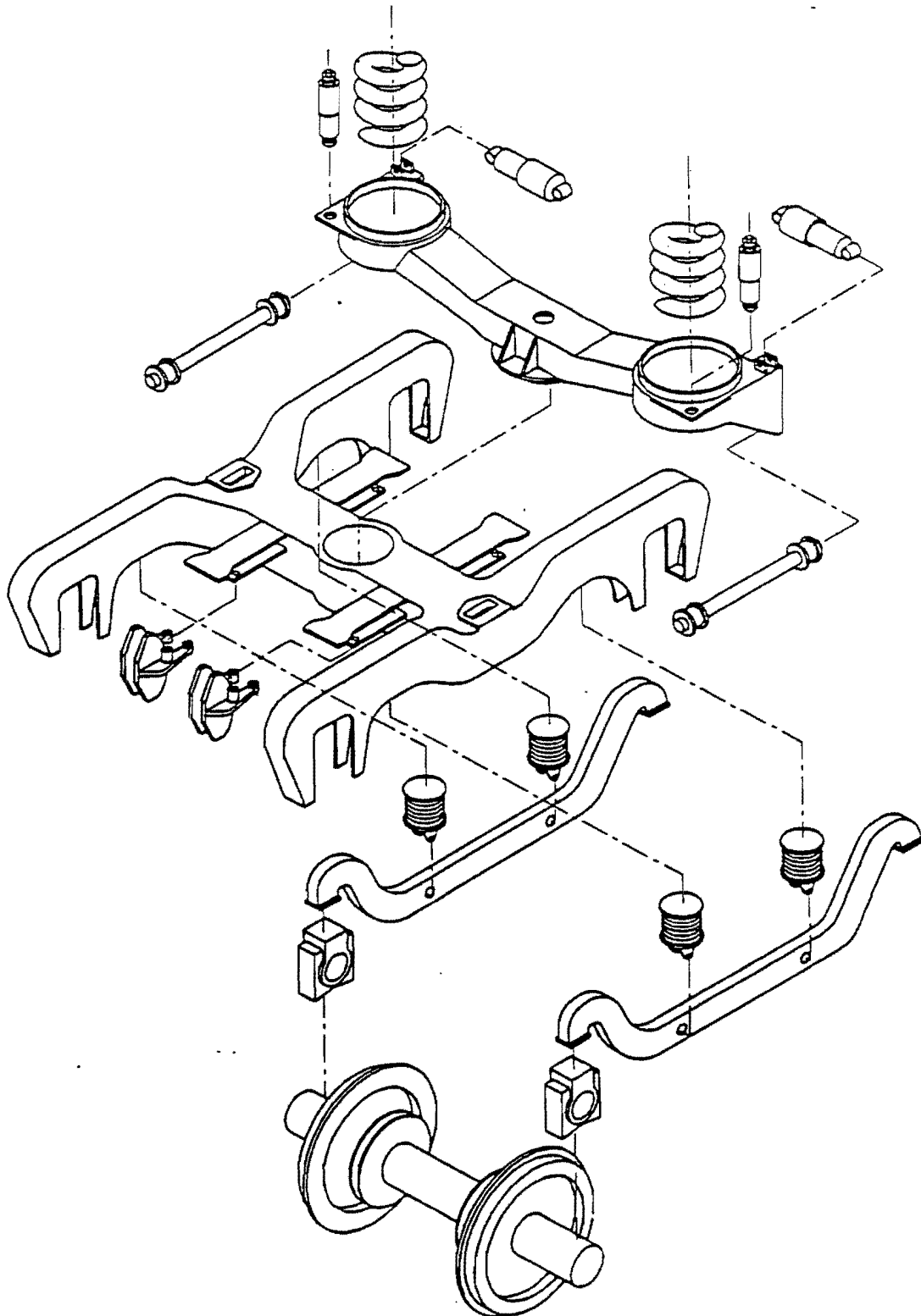
#### **A1.4.1.1 Narrative Description of Truck Design**

Truck Classification	32e
General Characteristics	This is an unpowered, rigid frame, outside journal bearing, equalizer beam design using a bolster with a center pin arrangement. Wheel alignment is provided by the pedestal guides for the journal bearing housings.
Frame	A cast steel H frame is used with a center hole and side bearing to accommodate the truck bolster.
Suspension System	
- Primary	The primary suspension is two coil spring packs between each equalizer and one side of the truck frame. Dampers are not used. Longitudinal and lateral wheelset restraint is provided by the pedestal guides.
- Secondary	The secondary suspension is two coil spring packs used between the truck bolster and the car underframe. At each side of the car a lateral shock absorber and a vertical shock absorber are connected between the end of the truck bolster and the car body for a total of four secondary shock absorbers per truck.
Propulsion System	N/A
Braking System	Two disks per axle plus one tread brake per wheel.

Exploded engineering and schematic drawings of this truck are provided in Figures A1.4.1 and A1.4.2.

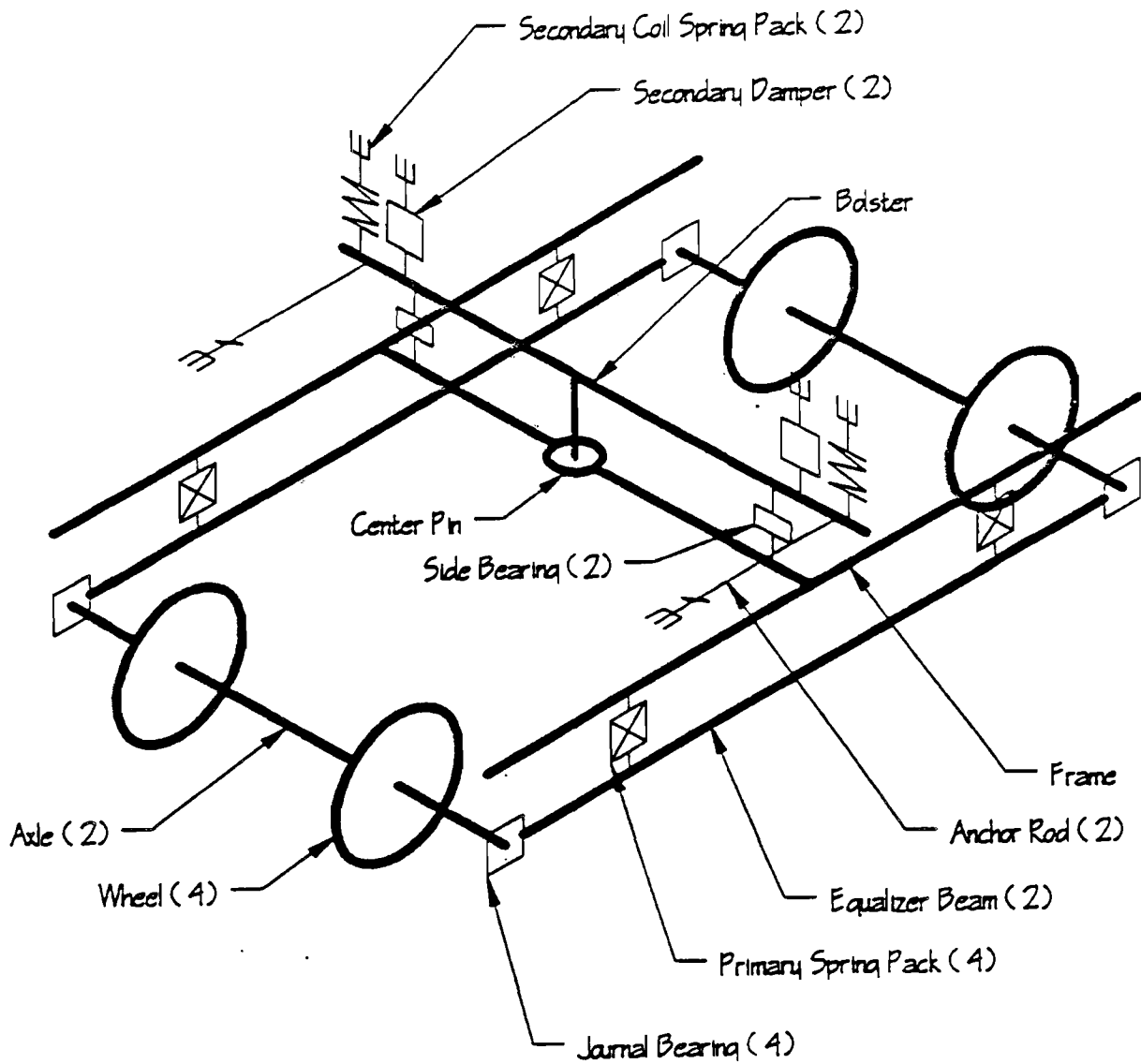


**A1.4: BUCKEYE/GSI-G70 FOR AMTRAK SUPERLINER II BI-LEVEL CAR  
(continued)**



**Figure A1.4.1 GSI Truck for Amtrak Superliner II - Exploded View**

**A1.4: BUCKEYE/GSI-G70 FOR AMTRAK SUPERLINER II BI-LEVEL CAR  
(continued)**



**Figure A1.4.2 GSI Truck for Amtrak Superliner II - Schematic**

**A1.4: BUCKEYE/GSI-G70 FOR AMTRAK SUPERLINER II BI-LEVEL CAR  
(continued)**

**A1.4.1.2 Basic Truck Data**

Track Gauge	1435 mm (56.5 in)
Wheel Base	2591 mm (102 in)
Wheel Diameter	914 mm (36 in)
Bolster Bowl Diameter	Approximately 305 mm (12 in)
Truck Rotational Break Out Torque	Not Available
Design Load (Top of Bolster Bowl)	296 kN (66500 lb <sub>f</sub> )
Total Truck Weight	Approximately 97.9 kN (22000 lb <sub>f</sub> )
Brake Type	2 disk brakes per axle 1 tread brake per wheel
Motor	None
Gear Box	None

A1.4.1.3 Truck Center of Gravity, Mass and Moment of Inertia

Component Description	Number of Components	Mass of 1 Component kg (lb <sub>f</sub> -sec <sup>2</sup> /in)	Center of Gravity Location mm (in)			Moment of Inertia kg-m <sup>2</sup> (lb <sub>f</sub> -in-sec <sup>2</sup> )		
			X	Y	Z	I <sub>xx</sub>	I <sub>yy</sub> *	I <sub>zz</sub>
Wheel & Axle Set	2	1940.0 (11.0)	1295.4 (51.00)	0.0	456.2 (18.00)	944 (8330)	0.13 (116)	944 (8330)
Truck Frame	1	2223.2 (12.69)	0.0	0.0	708.4 (27.89)	15.3 (13520)	12.6 (11182)	26.9 (23794)
Bolster	1	907.5 (5.18)	0.0	0.0	673.1 (26.5)	4.97 (4396)	0.28 (249)	5.13 (4542)
Equalizer Bar	2 outside 2 inside	192.7 (1.1) 192.7 (1.1)	0.0 0.0	1127.8 (44.4) 967.7 (38.1)	376.9 (14.84) 376.9 (14.84)	0.09 (78)	1.15 (1016)	1.06 (939)
Motor	---	---	---	---	---	---	---	---
Gear Box	---	---	---	---	---	---	---	---
Tread Brake Unit	4	67.9 (0.39)	***	***	***	***	***	***
Disk Brakes/ Brackets	4	192.7 (2.2)	***	***	***	***	***	***
Primary Spring	4	85.0 (0.485)	***	***	***	***	***	***
Secondary Vertical Damper	2	34.2 (0.195)	***	***	***	***	***	***
Secondary Lateral Damper	2	81.5 (0.465)	***	***	***	***	***	***
Anchor Rod	2	51.7 (0.295)	***	***	***	***	***	***
Coil Spring Assy Pack	2	51.7 (0.295)	***	***	***	***	***	***

--- Not applicable to this truck, or value not relevant  
 \* Non-rotating components only for wheel and axle set.  
 \*\*\* Value required, but not available or estimated

A1-46

A1.4: BUCKEYE/GSI-G70 FOR AMTRAK SUPERLINER II BI-LEVEL CAR  
 (continued)

**A1.4.1.4 Truck Suspension Parameters**

**A1.4.1.4.1 Primary Suspension**

Component	Stiffness N/mm (lb/in)			Damping Rates N sec/mm(lb <sub>f</sub> sec/in)			Clearance and Travel Tolerances mm (in)		
	Longi- tudinal	Lateral	Vertical	Longi- tudinal	Lateral	Vertical	Longi- tudinal	Lateral	Vertical
Individual Springs									
- Inside	---	---	---	---	---	---	---	---	---
- Outside	---	---	---	---	---	---	---	---	---
Double Coil Spring Set	---	---	---	---	---	---	---	---	---
Total	***	***	1795 (10244) per Journal	---	---	---	***	***	***

--- Not applicable to this truck, or value not relevant

\*\*\* Value required, but not available or estimated

**A1.4.1.4.2 Secondary Suspension**

Component	Stiffness N/mm(lb <sub>f</sub> /in.)			Damping Rates N sec/mm(lb <sub>f</sub> sec/in.)		
	Longitudinal	Lateral	Vertical	Longitudinal	Lateral	Vertical
Coil Spring	---	656 (3744)	***	---	---	---
Lateral Bumper (Bolster/Car)	---	***	---	---	---	---
Vertical Shock Absorber	---	---	---	---	---	***(†)
Lateral Shock Absorber	---	---	---	---	***(††)	---
Center Pivot	---	---	---	---	---	---
Anchor Assembly	***	---	---	---	---	---

Component	Clearance & Travel Tolerances mm(in.)			Torque or Friction Force		
	Longitudinal	Lateral	Vertical	Longitudinal	Lateral	Vertical
Coil Spring	---	---	***	---	---	---
Lateral Bumper (Bolster/Car)	---	12.7 (0.5)	---	---	---	---
Vertical Shock Absorber	---	---	***	---	---	---
Lateral Shock Absorber	---	***	---	---	---	---
Center Pivot	---	---	---	*** (Friction torque about vertical axis)		
Anchor Assembly	***	---	---	---	---	---

† Two Monroe 70148 450/truck

†† Two Monroe 70147 600/truck

--- Not applicable to this truck, or value not relevant

\*\*\* Value required, but not available or estimated

A1.4: BUCKEYE/GSI-G70 FOR ANTRAK SUPERLINER II BI-LEVEL CAR (continued)

**A1.4: BUCKEYE/GSI-G70 FOR AMTRAK SUPERLINER II BI-LEVEL CAR  
(continued)**

**A1.4.1.5 Narrative Description of Load Path**

**A1.4.1.5.1 Longitudinal**

The longitudinal load path beginning at the car body bolster anchor rod supports goes through the anchor rods, then to the outer position of the truck bolster, then to the center pin location of the truck frame, then to the pedestal liners to the journal bearing housing.

**A1.4.1.5.2 Lateral**

The lateral load path beginning at the car body to secondary springs interface then goes to the truck bolster, to the frame center pin, to the frame, to the equalizer springs, to the equalizer and then to the journal bearing housing. Pedestal limits lateral movement between wheelset journal and truck frame.

**A1.4.1.5.3 Vertical**

The vertical load path beginning at the car body to secondary spring interface goes through the secondary springs to the truck bolster, then to the side bearings and through to the frame, then to the primary equalizer springs, then to the equalizer and then to the journal bearing housing.

**A1.4.1.6 Wheel Profile**

1/20 wheel conicity.

**A1.4: BUCKEYE/GSI-G70 FOR AMTRAK SUPERLINER II BI-LEVEL CAR  
(continued)**

**A1.4.2 Operating Environment and Operating Experience Data**

**A1.4.2.1 Background Information/Car Series**

Operator	Amtrak
Type of Car	Long distance intercity car (transcontinental services)
Name of Car Series	Superliner II
Number in Service	128
Date(s) put into Service	1993-95
Manufacturer of Car	Bombardier
Type of Truck (Volpe/ADL Designation)	32e
Truck Manufacture and Model	GSI Arrangement G36500

**A1.4.2.2 Operating and Route Data**

Superliner II cars fitted with the GSI G70 outside frame truck are primarily used on Amtrak's long-distance western routes between the mid-west and west coast destinations. Most operations are limited to 79 mph by the lack of automatic train-control (ATC), but speeds of 90-100 mph are attained in some locations where train control is available.

Train Lengths Operated	Up to 20 cars, including Superliner bi-level and single-level equipment.
------------------------	--

Braking Patterns (Friction/Dynamic)	Friction braking on train. Dynamic braking on locomotive for speed control. Long distance service with widely-spaced stops, typically 1-3 hours apart. Many routes have long downgrades where locomotive dynamic brakes are used with the train friction brakes to hold safe speed.
--	---





**A1.4: BUCKEYE/GSI-G70 FOR AMTRAK SUPERLINER II BI-LEVEL CAR  
(continued)**

**A1.4.2.4 Maintenance and Service Experience**

Regular Servicing and Inspection Schedules	Routine servicing done for wheels, brakes, shims, lubrication, etc.
Rationale for Maintenance Schedules	Expect excellent service life with six year overhaul period to be established by FRA rules for friction brake system.
Average or Typical Intervals (time or miles) Between Maintenance Action or Component Replacement	Overhaul expected at about one million miles.
Information on any Unusual Problems with Truck	None. This design is based on similar designs used on earlier single-level Amtrak cars.
Information on the Maintainability of the Truck	Maintenance is routine as it is the same as that required for other similar GSI or Buckeye designs.
Information on the Operator's Experience with the Truck	Good experience on Superliner II with very minimum wear shown.

## **A1.4: BUCKEYE/GSI-G70 FOR AMTRAK SUPERLINER II BI-LEVEL CAR (continued)**

### **A1.4.3. Engineering Data on Railroad Passenger Cars and Car-Truck Interface**

#### **A1.4.3.1 General Description of Car**

The Rockwell G70 outside frame truck is applied to Amtrak's Superliner II bi-level long-distance cars. The cars have a full length upper level and a shorter lower level between the trucks. Miscellaneous equipment such as braking, HVAC and toilet systems are housed in the space above the trucks and below the upper level. The cars are being built over the period 1993-1995, for use in long-distance services in the western part of the U.S., and between Washington DC and Florida. The G70 outside frame truck is also applied to the Horizon and Viewliner series of Amtrak single-level cars, and to bi-level cars being purchased by the California Department of Transportation.

#### **A1.4.3.2 Car and Body Data**

##### Overall Dimensions

Car Length (over coupler faces)	25.91 m (85.0 ft)
Width	3.10 m (10.2 ft)
Height (from top of rail)	4.92 m (16.1 ft)

##### Truck Center Spacing

18.14 m (59.5 ft)

##### Car Weight

Ready to Run	672 to 719 kN (151000 to 161500 lb <sub>f</sub> )
With Maximum Load	719 to 757 kN (161500 to 170200 lb <sub>f</sub> )

Note: the weight range covers the different versions of this car: sleepers, diners and coach cars.

##### Mass of Car Body

(without trucks) (ready to run) 48535-53298 kg (3323-3741 lb-sec<sup>2</sup>/ft)

##### Radius of gyration about center of gravity

Roll	2.00 m (6.7 ft) Est
Pitch	7.57 m (24.8 ft) Est
Yaw	7.57 m (24.8 ft) Est

##### Center of Gravity of Car Body (from top of rail)

2.20 m (7.5 ft) Est

##### Car Body Natural Frequency (first vertical bending mode)

8.0-8.5 Hz (Est)

**A1.4: BUCKEYE/GSI-G70 FOR AMTRAK SUPERLINER II BI-LEVEL CAR  
(continued)**

**A1.4.3.3 Car Body to Truck Interface**

The car body rests on two steel coil springs at each truck which rest on the truck bolster. The longitudinal connection between the truck and the car body is via two laterally spaced longitudinal anchor rods between the car body and the truck bolster. Secondary vertical dampers are provided in parallel with the cant springs.

Specific dimensions are as follows:

Lateral spacing of coil spring	2.18 m (7.17 ft)
Lateral spacing of anchor rods	2.72 m (8.92 ft)
Height of anchor rods above top of rail	0.48 m (1.58 ft)

**A1.5: WAGGON UNION MD-76 FOR AMTRAK SUPERLINER I BI-LEVEL CAR**

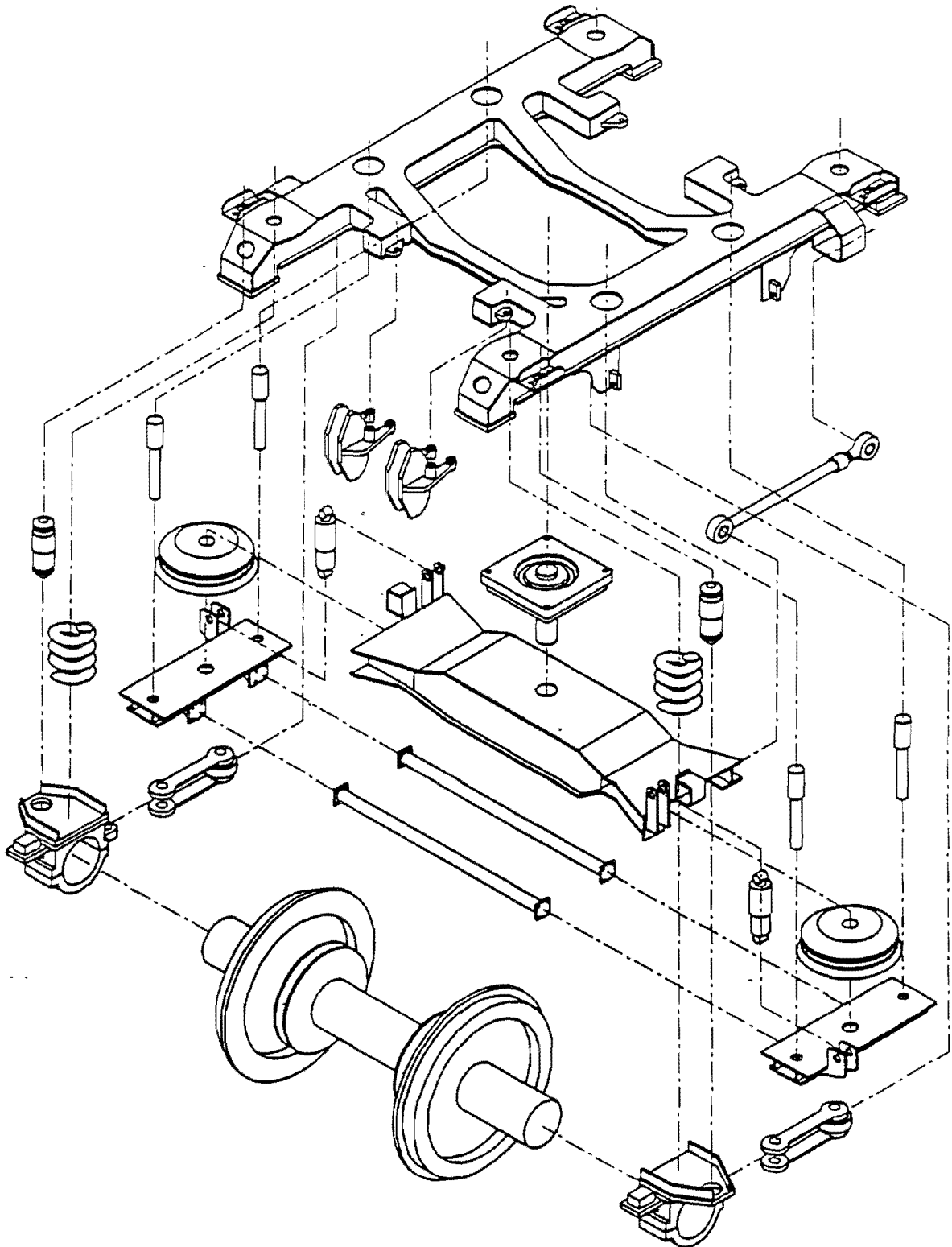
**A1.5.1 Engineering Data**

**A1.5.1.1 Narrative Description of Truck Design**

Truck Classification	41e
General Characteristics	This is an unpowered rigid frame, outside journal bearing design with an inside swing hanger secondary. Axle alignment is provided by rubber-metal leaf guiders connected between the axle bearings and the frame.
Frame	The frame is a fabricated doubled cross beam design with limited torsional elasticity. The frame supports the spring plank through links.
Suspension System	
- Primary	The primary suspension uses coil springs located on top of the axle bearing housing with parallel hydraulic dampers on all four of these bearings. The axle is located in the longitudinal and lateral direction by horizontal leaf-spring guides.
- Secondary	The secondary vertical suspension uses air springs with hydraulic dampers. Swing hangers and lateral hydraulic dampers provide the lateral suspension.
Propulsion System	N/A
Braking System	Disc brakes, 2 per axle

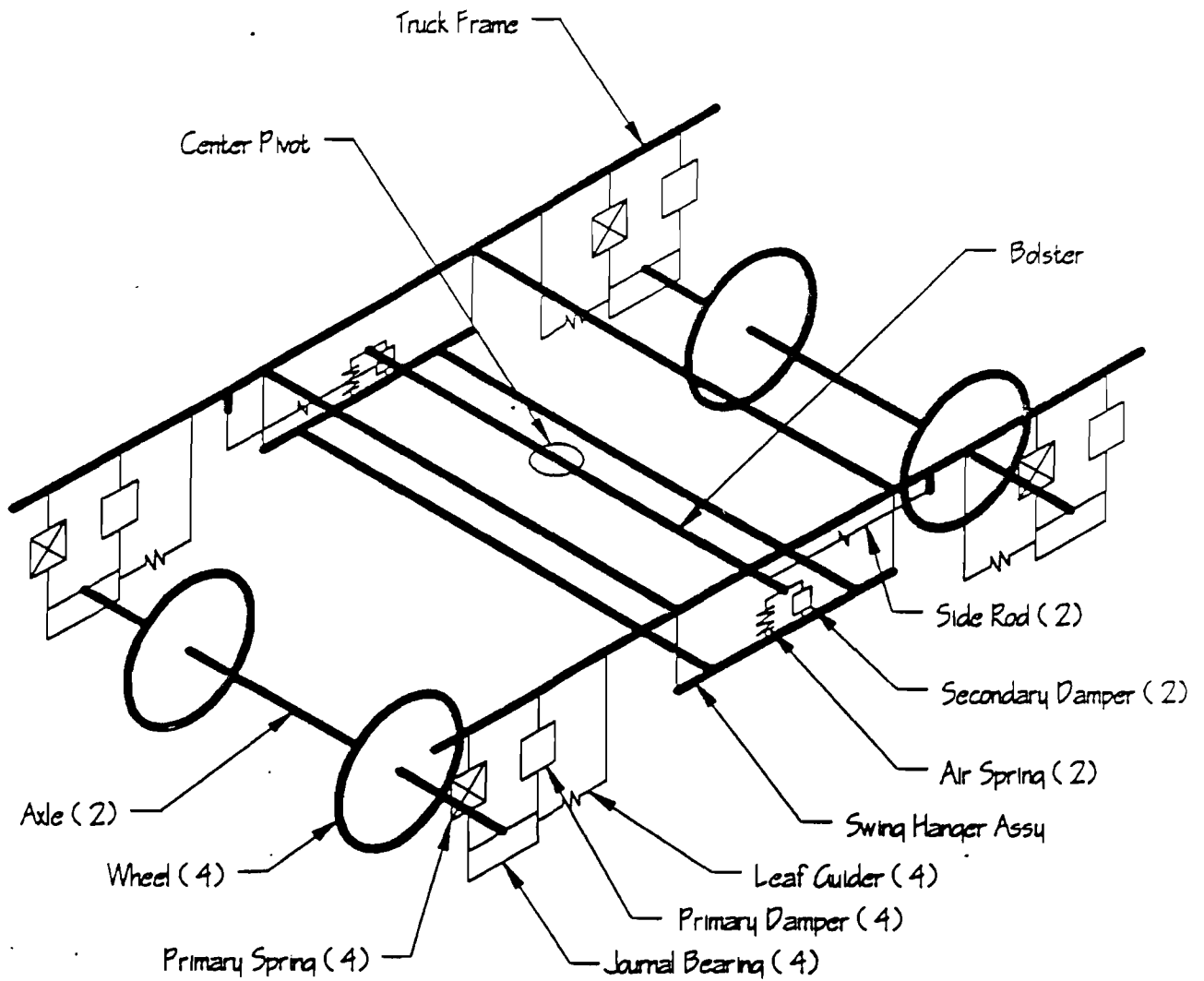
Exploded engineering and schematic drawings of this truck are provided in Figures A1.5.1 and A1.5.2.

**A1.5: WAGGON UNION MD-76 FOR AMTRAK SUPERLINER I BI-LEVEL  
CAR (continued)**



**Figure A1.5.1 Waggon Union MD76 for Amtrak Superliner 1 - Exploded View**

**A1.5: WAGGON UNION MD-76 FOR AMTRAK SUPERLINER I BI-LEVEL CAR (continued)**



**Figure A1.5.2 Waggon Union MD76 for Amtrak Superliner I - Schematic**

**A1.5: WAGGON UNION MD-76 FOR AMTRAK SUPERLINER I BI-LEVEL  
CAR (continued)**

**A1.5.1.2 Basic Truck Data**

Track Gauge	1435 mm (56.5 in)
Wheel Base	2600 mm (102.4 in)
Wheel Diameter	914 mm (36.0 in)
Bolster Bowl Diameter	508 mm (20 in)
Truck Rotational Break Out Torque	Not available
Design Load (Top of Bolster Bowl)	292 kN (66,000 lb <sub>f</sub> ) minimum (est)
Total Truck Weight	85.65 kN (19246 lb <sub>f</sub> )
Brake Type	Two disc brakes per axle
Motor	N/A
Gear Box	N/A



A1.5.1.3 Truck Center of Gravity, Mass and Moment of Inertia

Component Description	Number of Components	Mass of 1 Component kg (lb <sub>f</sub> -sec <sup>2</sup> /in)	Center of Gravity Location mm (in)			Moment of Inertia kg-m <sup>2</sup> (lb <sub>f</sub> -in-sec <sup>2</sup> )		
			X	Y	Z	I <sub>xx</sub>	I <sub>yy</sub> *	I <sub>zz</sub>
Wheel & Axle Set	2	2024.0 (11.5)	1300.0 (51.0)	0.0	457.2 (18.0)	1076 (9504)	0.06 (49)	1076 (9504)
Truck Frame	1	988.1 (5.5)	0.0	0.0	827.8 (32.59)	7.1 (6301)	5.3 (4711)	12.4 (10927)
Bolster	1	727.1 (4.15)	0.0	0.0	559.1 (22.01)	2.8 (2442)	0.28 (252)	2.9 (2541)
Equalizer Bar	---	---	---	---	---	---	---	---
Motor	---	---	---	---	---	---	---	---
Gear Box	---	---	---	---	---	---	---	---
Tread Brake Unit	---	---	---	---	---	---	---	---
Disc Brakes	4	31.3 (1.78)	***	***	***	***	***	***
Primary Spring	4 sets	90.7 (0.52)	***	***	***	***	***	***
Secondary Vertical Damper	2	34.2 (0.195)	***	***	***	***	***	***
Secondary Lateral Damper	2	***	***	***	***	***	***	***
Anchor Rod	2	***	***	***	***	***	***	***
Air Spring Assembly	2	91.1 (0.52)	***	***	***	***	***	***

--- Not applicable to this truck, or value not relevant

\* Non-rotating components only for wheel and axle set

\*\*\* Value required, but not available or estimated

A1-59

A1.5: WAGGON UNION MD-76 FOR AMTRAK SUPERLINER I BI-LEVEL  
CAR (continued)

**A1.5.1.4 Truck Suspension Parameters**

**A1.5.1.4.1 Primary Suspension**

Component	Stiffness N/mm (lb/in)			Damping Rates N sec/mm(lb <sub>f</sub> sec/in)			Clearance and Travel Tolerances mm (in)		
	Longi- tudinal	Lateral	Vertical	Longi- tudinal	Lateral	Vertical	Longi- tudinal	Lateral	Vertical
Individual Springs									
- Inside	---	---	---	---	---	---	---	---	---
- Outside	---	---	---	---	---	---	---	---	---
Double Coil Spring Set	***	8.3x10 <sup>3</sup> (44.7x10 <sup>3</sup> )  (per wheel figures)	1.35x10 <sup>3</sup> (7.27x10 <sup>3</sup> )	---	12.5 (70)  (per wheel figures)	1.51 (84)	***	***	***

--- Not applicable to this truck, or value not relevant

\*\*\* Value required, but not available or estimated

Note: Data taken from Reference 3

**A1.5.1.4.2 Secondary Suspension**

Component	Stiffness N/mm(lb <sub>f</sub> /in.)			Damping Rates N sec/mm(lb <sub>f</sub> sec/in.)		
	Longitudinal	Lateral	Vertical	Longitudinal	Lateral	Vertical
Air Spring	---	---	1.03x10 <sup>3</sup> (554x10 <sup>3</sup> )	---	---	---
Swing Hangers	---	***	---	---	---	---
Lateral Bumper (Bolster/Car)	---	***	---	---	---	---
Vertical Shock Absorber	---	---	---	---	---	37 (200)
Lateral Shock Absorber	---	---	---	---	81 (438)	---
Center Pivot	---	---	---	---	---	---
Anchor Assembly	***	---	---	---	---	---

Component	Clearance & Travel Tolerances mm (in.)			Torque or Friction Force		
	Longitudinal	Lateral	Vertical	Longitudinal	Lateral	Vertical
Spring Side Bearing	---	---	***	---	---	---
Lateral Bumper (Bolster/Car)	---	***	---	---	---	---
Vertical Shock Absorber	---	---	***	---	---	---
Lateral Shock Absorber	---	***	---	---	---	---
Center Pivot	---	---	---	114x10 <sup>6</sup> N-MM/rad (0.817x10 <sup>6</sup> lb-in/rad)		
Anchor Assembly	***	---	---	---	---	---

--- Not applicable to this truck, or value not relevant  
 \*\*\* Value required, but not available or estimated

Note: Data taken from Reference 3

A1-61

A1.5: WAGGON UNION MD-76 FOR AMTRAK SUPERLINER 1 BI-LEVEL  
 CAR (continued)

## **A1.5: WAGGON UNION MD-76 FOR AMTRAK SUPERLINER | BI-LEVEL CAR (continued)**

### **A1.5.1.5 Narrative Description of Load Path**

#### **A1.5.1.5.1 Longitudinal**

The longitudinal force from the car body is transmitted to the truck bolster through a center pin. The bolster transmits this force to the frame through rods on the outside of the frame which in turn is connected by leaf guiders to each axle bearing housing. At high force levels force can also be transmitted from the bolster directly to the frame through travel stops.

#### **A1.5.1.5.2 Lateral**

The car body to truck bolster lateral force is through the center pin. The force continues through the secondary suspension to the spring plank that moves on its pendulum supports and transmits force to the truck frame and finally to the axle bearings. Lateral damping is used between the bolster and the frame.

#### **A1.5.1.5.3 Vertical**

The car body rests on the truck bolster at the center pin. Load is distributed along the bolster to the secondary air springs and then to the spring plank and its support hangers that are suspended from the frame. The frame is supported by springs supported on top of the axle bearing housing.

**A1.5: WAGGON UNION MD-76 FOR AMTRAK SUPERLINER I BI-LEVEL CAR (continued)**

**A1.5.2 Operating Environment and Operating Experience Data**

**A1.5.2.1 Background Information/Car Series**

Operator	Amtrak
Type of Car	Long-Distance Intercity (transcontinental services)
Name of Car Series	Superliner I
Number in Service	282
Date(s) put into Service	1978-1981
Manufacturer of Car	Pullman-Standard
Type of Truck (Volpe/ADL Designation)	41e
Truck Manufacture and Model	Waggon Union (New York Air Brake as Licensee) MD-76

**A1.5.2.2 Operating and Route Data**

Superliner I cars fitted with the MD76 truck are primarily used on Amtrak's long-distance Western routes between the mid-west and west coast destinations. Most operations are limited to 79 mph by the lack of automatic train control, but speeds of 90-100 mph are attained in some locations where train control is available.

Train Lengths Operated	Up to 20 cars, including Superliner cars, and single-level equipment
Braking Patterns (Friction/Dynamic)	Long-distance service with widely-spaced stops, typically 1-3 hours apart. Many routes have long downgrades where locomotive dynamic brakes are used with train brakes to hold safe speed.



**A1.5: WAGGON UNION MD-76 FOR AMTRAK SUPERLINER I BI-LEVEL  
CAR (continued)**

**A1.5.2.4 Maintenance and Service Experience**

Regular Servicing and Inspection  
Schedules

Three years for heavy overhaul.  
Servicing on routine basis.

Rationale for Maintenance Schedules

Provide an acceptable failure rate.

Average or Typical Intervals  
(time or miles) between Maintenance  
Action or Component Replacement

500,000 miles typical.

Information on any Unusual  
Problems with Truck

A wide range of problems initially that were  
corrected by the manufacturer.

Information on the Maintainability  
of the Truck

Leaf guider requires adjustment. Several  
wearing and pivoting surfaces need  
attention.

Information on the Operator's  
Experience with the Truck

Experience has been a shorter overhaul  
period than trucks based on previous U.S.  
designs.

## **A1.5: WAGGON UNION MD-76 FOR AMTRAK SUPERLINER I BI-LEVEL CAR (continued)**

### **A1.5.3 Engineering Data on Railroad Passenger Cars and Car-Truck Interface**

#### **A1.5.3.1 General Description of Car**

The MD76 truck is applied to Amtrak's Superliner I bi-level long-distance cars. The cars have a full length upper level and a shorter lower level between the trucks. Miscellaneous equipment such as braking, HVAC and toilet systems are housed in the space above the trucks and below the upper level. The cars were built over the period 1978-1982, and are used in long-distance services in the western part of the U.S.

#### **A1.5.3.2 Car and Car Body Data**

##### Overall Dimensions

Car Length (over coupler faces)	25.91 m (85.0 ft)
Width	3.10 m (10.2 ft)
Height (from top of rail)	4.92 m (16.1 ft)

Truck Center Spacing	18.14 m (59.5 ft)
----------------------	-------------------

##### Total Car Weight

Ready to Run	670 kN (151,000 lb <sub>f</sub> )
With Maximum Load	730 kN (164,800 lb <sub>f</sub> )

Mass of Car Body (without trucks)  
(ready to run)

50838 kg (3480 lb-sec<sup>2</sup>/ft)

##### Radius of gyration

Roll	2.00 m (6.7 ft) (Est)
Pitch	7.57 m (24.8 ft) (Est)
Yaw	7.57 m (24.8 ft) (Est)

Center of Gravity of Car Body  
from Top of Rail

2.20 m (7.5 ft) (Est)

Car body natural frequency  
(first vertical bending mode)

8.5 Hz (Est)

#### **A1.5.3.3 Car Body and Truck Interface**

The car body rests on a center pivot and is secured to the truck bolster by a large bolt running through the truck and car body components of the center pivot. Excess lateral rocking is controlled by non-contacting sidebearers on the truck bolster at 1.40 m (4-6 ft) lateral spacing. Anchor rods between truck and car body are not required.



## A1.6: KAWASAKI TRUCK FOR MBTA BI-LEVEL COMMUTER CAR

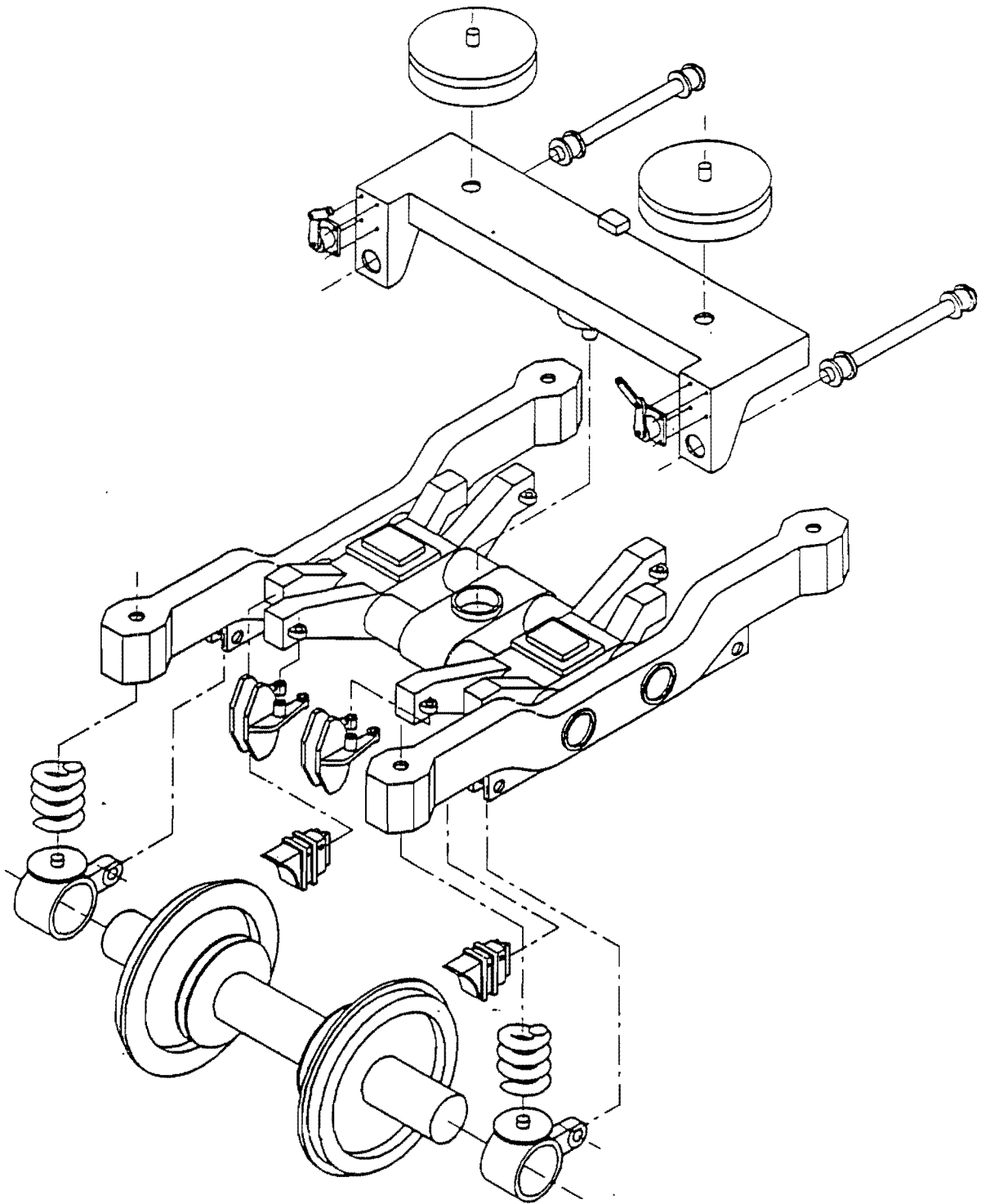
### A1.6.1 Engineering Data

#### A1.6.1.1 Narrative Description of Truck Design

Truck Classification	42e
General Characteristics	This truck is used with the Kawasaki bi-level commuter cars operated by MBTA (Boston commuter service). It uses a fabricated H truck frame and bolster with outside journal bearings.
Frame	<p>The frame is of welded steel and consists of two side beams of box structure and two cross beams of pipe structure. Two side bearings that use a special resin are located on the cross beams.</p> <p>The truck bolster is a welded box structure that is also used as an auxiliary air supply for the air springs. A center pivot with a nylon brushing provides the interface between the frame and truck bolster.</p>
Suspension System	
- Primary	The primary suspension also provides wheel set guidance by using a radius arm between the truck frame and the journal bearing. The primary spring is an arrangement of multiple steel coil springs supported on the journal bearing housing through a rubber pad.
- Secondary	An air spring secondary is used that contains a back-up rubber spring with a Teflon sheet to operate in emergency conditions if air is lost. The air spring is also used to level the car with varying passenger load. Lateral movement is limited by rubber stops on the truck bolster. Vertical movement is limited by a stop between the body and truck bolsters. Damping is provided for lateral and vertical motion by two rotary shock absorbers connected between the truck bolster and the car body.
Propulsion & Braking System	This truck is unpowered. Two disc brakes are mounted on each axle and one tread brake unit is mounted at each wheel.

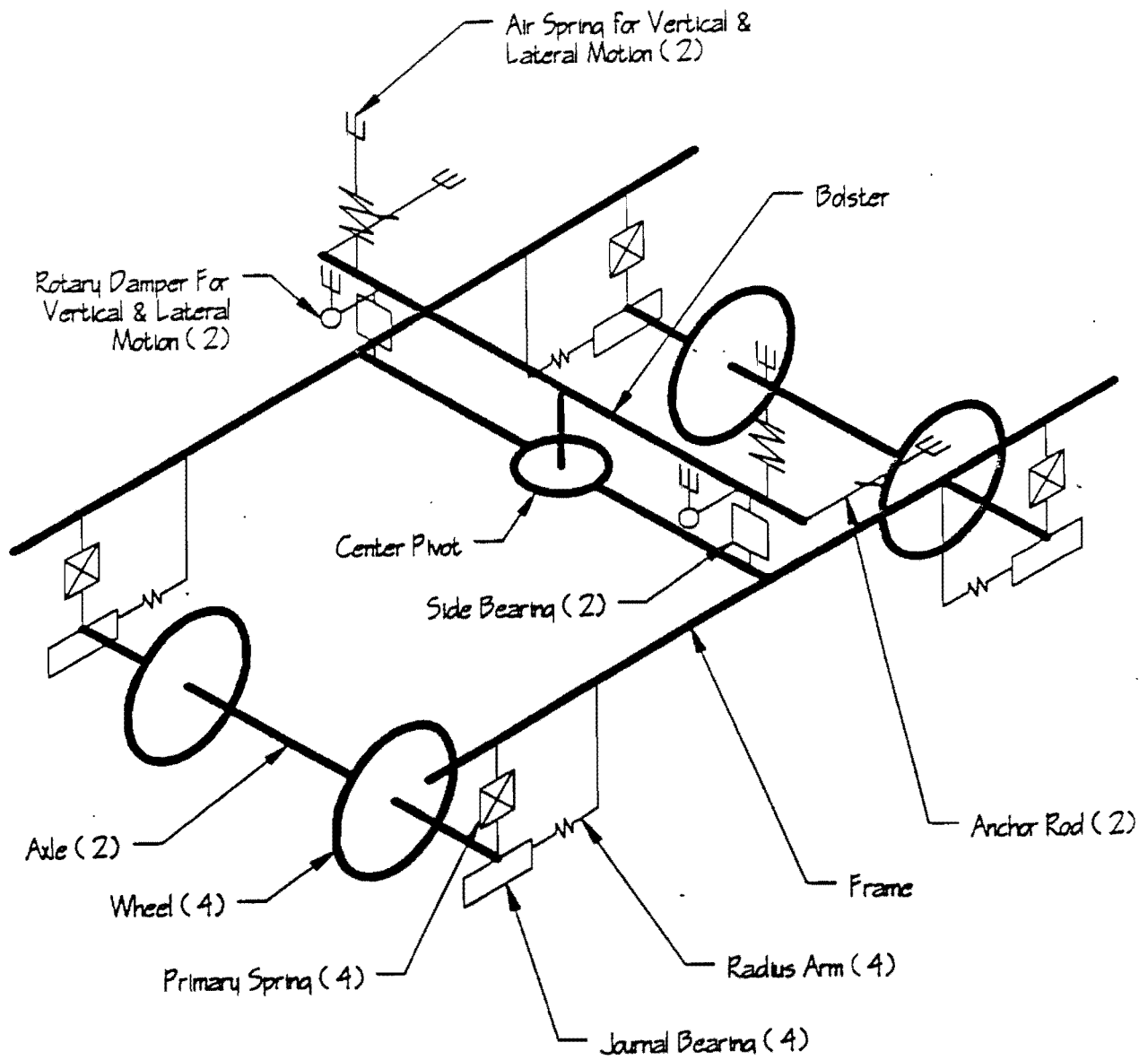
Exploded engineering and schematic drawings of this truck are provided in Figures A1.6.1 and A1.6.2.

**A1.6: KAWASAKI TRUCK FOR MBTA BI-LEVEL COMMUTER CAR**  
(continued)



**Figure A1.6.1 Kawasaki Truck for Kawasaki Bi-Level for MBTA - Exploded View**

**A1.6: KAWASAKI TRUCK FOR MBTA BI-LEVEL COMMUTER CAR  
(continued)**



**Figure A1.6.2 Kawasaki Truck for Kawasaki Bi-Level for MBTA - Schematic**

**A1.6: KAWASAKI TRUCK FOR MBTA BI-LEVEL COMMUTER CAR  
(continued)**

**A1.6.1.2 Basic Truck Data**

Track Gauge	1435 mm (56.5 in)
Wheel Base	2591 mm (102 in)
Wheel Diameter	915 mm (36 in)
Bolster Bowl Diameter	Approx. 254 mm (10 in)
Truck Rotational Break Out Torque	Not Available
Design Load (Top of Bolster Bowl)	650 kN (146000 lb <sub>f</sub> ) (Est)
Total Truck Weight	74.09 kN (16650 lb <sub>f</sub> )
Brake Type	Two disc brakes per axle, one tread brake unit per wheel.
Motor	None
Gear Box	None

A1.6.1.3 Truck Center of Gravity, Mass and Moment of Inertia

Component Description	Number of Components	Mass of 1 Component kg (lb <sub>r</sub> sec <sup>2</sup> /in)	Center of Gravity Location mm (in)			Moment of Inertia kg-m <sup>2</sup> (lb <sub>r</sub> -in-sec <sup>2</sup> )		
			X	Y	Z	I <sub>xx</sub>	I <sub>yy</sub> *	I <sub>zz</sub>
Wheel & Axle Set	2	2086 (11.87)	1295.4 (51.00)	0.0	457.2 (18.0)	978 (8631)	0.07 (58)	978 (8631)
Truck Frame	1	1801.0 (10.28)	0.0	0.0	563.4 (22.18)	13.9 (12289)	9.1 (8012)	21.9 (19396)
Booster	1	681.5 (3.89)	0.0	0.0	723.9 (28.50)	2.6 (2331)	0.14 (125)	2.7 (2417)
Equalizer Bar	---	---	---	---	---	---	---	---
Motor	---	---	---	---	---	---	---	---
Gear Box	---	---	---	---	---	---	---	---
Tread Brake Unit & Disc	4	313 (1.78)	***	***	***	***	***	***
Primary Spring	4	127 (0.73)	***	***	***	***	***	***
Secondary Vertical Damper	2	35.0 (0.2)	***	***	***	***	***	***
Secondary Lateral Damper	2	35.0 (0.2)	***	***	***	***	***	***
Anchor Rod	2	43.8 (0.25)	***	***	***	***	***	***
Air Spring Assembly	2	85.7 (6.49)	***	***	***	***	***	***

--- Not applicable to this truck, or value not relevant  
 \* Non-rotating components only for wheel and axle set  
 \*\*\* Value required, but not available or estimated

A1-71

A1.6: KAWASAKI TRUCK FOR MBTA BI-LEVEL COMMUTER CAR  
 (continued)

**A1.6.1.4 Truck Suspension Parameters**

**A1.6.1.4.1 Primary Suspension**

Component	Stiffness N/mm (lb/in)			Damping Rates N sec/mm(lb <sub>f</sub> sec/in)			Clearance and Travel Tolerances mm (in)		
	Longi- tudinal	Lateral	Vertical	Longi- tudinal	Lateral	Vertical	Longi- tudinal	Lateral	Vertical
Individual Springs									
- Inside	---	---	---	---	---	---	---	---	---
- Outside	---	---	---	---	---	---	---	---	---
Double Coil Spring Set	---	---	686.8 (3920)	---	---	1.05 (6)	---	---	***
Radius Arm Assembly	***	***	---	---	---	---	***	***	---

--- Not applicable to this truck, or value not relevant

\*\*\* Value required, but not available or estimated

**A1.6.1.4.2 Secondary Suspension**

Component	Stiffness N/mm(lb/in.)			Damping Rates N sec/mm(lb <sub>f</sub> sec/in.)		
	Longitudinal	Lateral	Vertical	Longitudinal	Lateral	Vertical
Air Spring	---	***	550 (3140)	---	---	---
Lateral Bumper (Bolster/Car)	---	***	---	---	***	---
Vertical Shock Absorber	---	---	---	---	---	45.55 (260)
Lateral Shock Absorber	---	---	---	---	***	---
Center Pivot	---	---	---	---	---	---
Anchor Assembly	***	---	---	---	---	---

Component	Clearance & Travel Tolerances mm (in.)			Torque or Friction Force		
	Longitudinal	Lateral	Vertical	Longitudinal	Lateral	Vertical
Spring Side Bearing	---	---	***	***	---	---
Lateral Bumper (Bolster/Car)	25.4 (1.00)	39.9 (1.57)	39.9 (1.57)	---	---	---
Vertical Shock Absorber	---	---	***	---	---	---
Lateral Shock Absorber	---	***	---	---	---	---
Center Pivot	---	---	---	*** (rotational friction about vertical axis)		
Anchor Assembly	***	---	---	---	---	---

--- Not applicable to this truck, or value not relevant

\*\*\* Value required, but not available or estimated

**A1.6: KAWASAKI TRUCK FOR MBTA BI-LEVEL COMMUTER CAR  
(continued)**

**A1.6.1.5 Narrative Description of Load Path**

**A1.6.1.5.1 Longitudinal**

The load path in the longitudinal direction is from the car body to the two bolster anchor rods, to the truck bolster, to the center pin, to the truck frame, to the radius rods and then to the journal bearing housing.

**A1.6.1.5.2 Lateral**

The load path in the lateral direction is from the car body to air springs, to the truck bolster, to the center pin, to the truck frame, to the radius rods and then to the journal bearing housings.

**A1.6.1.5.3 Vertical**

The load path in the vertical direction is from the car body to the air springs, to the side bearings, to the truck frame, through the coil spring and rubber pad assembly located on top of the journal bearing.

**A1.6.1.6 Wheel Profile Drawing**

Narrow flange tapered contour.



**A1.6: KAWASAKI TRUCK FOR MBTA BI-LEVEL COMMUTER CAR  
(continued)**

**A1.6.2 Operating Environment and Operating Experience Data**

**A1.6.2.1 Background Information/Car Series**

Operator MBTA (Boston) Commuter Service  
 Type of Car Commuter, bi-level, unpowered  
 Name of Car Series Kawasaki bi-level  
 Number in Service 75  
 Date(s) put into Service 1992-1993  
 Manufacturer of Car Kawasaki Heavy Industries, Ltd.  
 Type of Truck (Volpe/ADL Designation) 42e  
 Truck Manufacturer and Model Kawasaki Radius Arm Fabricated

**A1.6.2.2 Operating and Route Data**

	Route	(Length) Mileage	(Stops) Stations	Speed (Max)
NORTH	Rockport	35	12	60
	Haverhill	33	13	60
	Lowell	26	7	60
	Fitchburg	49	18	60
SOUTH	Providence	43	12	80
	Framingham	21	10	60
	Needham	14	11	80
	Franklin	31	16	60

Train Lengths Operated: 5-9 cars

Braking Patterns (Friction/Dynamic) Policy is to use dynamic brake. Eighteen of 55 locomotives not equipped with dynamic brake. Policy is to run with EP brake, to cut out Bombardier 350 series which do not have EP brake.



**A1.6: KAWASAKI TRUCK FOR MBTA BI-LEVEL COMMUTER CAR  
(continued)**

**A1.6.2.4 Maintenance and Service Experience**

Regular Servicing and Inspection Schedules	New track: not yet determined.
Rationale for Maintenance Schedules	This truck has not operated for a sufficient duration or mileage to establish an optimum maintenance schedule.
Average or Typical Intervals (time or miles) between Maintenance Action or Component Replacement	New track: not yet determined.
Information on any Unusual Problems with Truck	Derailment problem on sharp curves in yards, currently under investigation.
Information on the Maintainability of the Truck	New track: not yet determined.
Information on the Operator's Experience with the Truck	New track: not yet determined.

**A1.6.3 Engineering Data on Railroad Passenger Cars and Car-Truck Interface**

**A1.6.3.1 General Description of Car**

The car is a bi-level commuter coach car manufactured by Kawasaki. Approximately 30% of the cars are equipped with a control cab for push-pull operation and the remainder are blind trailer cars. The car body is of stainless steel welded construction. Two levels are provided between the trucks, accessed by up and down stairways from a vestibule area with a conventional floor height at the ends of the car.

**A1.6.3.2 Car and Car Body Data**

Overall Dimensions	
Car Length (over coupler faces)	26.00 m (85.3 ft)
Width	3.05 m (10.0 ft)
Height (from top of rail)	4.72 m (15.5 ft)
Truck Center Spacing	19.05 m (62.5 ft)

## A1.6: KAWASAKI TRUCK FOR MBTA BI-LEVEL COMMUTER CAR (continued)

Car Weight Ready to Run	
- Trailer car	540 kN (121000 lb <sub>f</sub> )
- Cab car	560 kN (126000 lb <sub>f</sub> )
With maximum load	
- Trailer car	670 kN (149675 lb <sub>f</sub> )
- Cab car	680 kN (153125 lb <sub>f</sub> )
Mass of car body (without trucks) (ready to run)	
- Trailer car	39959 kg (2724 lb-sec <sup>2</sup> /ft)
- Cab car	41998 kg (2879 lb-sec <sup>2</sup> /ft)
Radius of gyration	
- Roll	1.83 m (6.0 ft) (Est)
- Pitch	7.47 m (24.5 ft) (Est)
- Yaw	7.47 m (24.5 ft) (Est)
Center of gravity of car body (from top of rail)	1.98 m (6.5 ft) (Est)
Car body natural frequency (first vertical bending mode)	7.5-8.0 Hz (Est)

### A1.6.3.3 Car Body to Truck Interface

The car body rests on two air springs at each truck situated at the outer ends of the truck bolster. The longitudinal connection between the car body and the truck bolsters is provided by two laterally spaced longitudinal anchor rods. Secondary vertical and lateral dampers (two of each) are also provided between the bolster and the car body.

Approximate dimensions are as follows:

Lateral spacing of air springs	2.13 m (7.0 ft)
Lateral spacing of second dampers	2.74 m (9.0 ft)
Lateral spacing of anchor rods	2.62 m (8.6 ft)
Height of anchor rods above top of rail	0.48 m (1.58 ft)

## **A1.7: NIPPON SHARYO TRUCK FOR MARC II COMMUTER CAR**

### **A1.7.1 Engineering Data**

#### **A1.7.1.1 Narrative Description of Truck Design**

Truck Classification	42e
General Characteristics	This unpowered truck is a fabricated design that is Amtrak-approved to operate at 200 km/hr. It was produced by NIPPON SHARYO with designation NT-319 and is used by the Marc II (Maryland) commuter cars and in a powered form (NT312) on the Northern Indiana CTD EMU commuter cars. It is a rigid frame design with outboard journal bearings.
Frame	The welded H frame and bolster use steel plate and forgings. The inside of the bolster also is used as an auxiliary air reservoir for the secondary air springs.
Suspension System	
- Primary	The primary suspension uses cylindrical guide type Eligo (coil/rubber combination) springs that are supported on winged journal bearing housings. Two spring assemblies are used at each journal bearing.
- Secondary	Diaphragm type air springs are installed between the car body and the truck bolster with hydraulic lateral and vertical shock absorbers also used at this same interface. The air springs have a back-up rubber spring. Floor height is also maintained by the air springs with changing passenger load. Truck rotation is provided by the truck bolster rotating on the truck frame on side bearing wear plates. The truck bolster uses a center pin connection to the truck frame and two anchor rods for connection to the car body.
Propulsion & Braking System	This truck as used with the MARC II commuter car is unpowered. Friction braking is provided with two cast iron disc brakes on each axle and a single shoe tread brake unit used for each wheel. The disc brake actuators are supported by the truck frame.

Exploded engineering and schematic drawings of this truck are provided in Figures A1.7.1 and A1.7.2.

A1.7: NIPPON SHARYO TRUCK FOR MARC II COMMUTER CAR (continued)

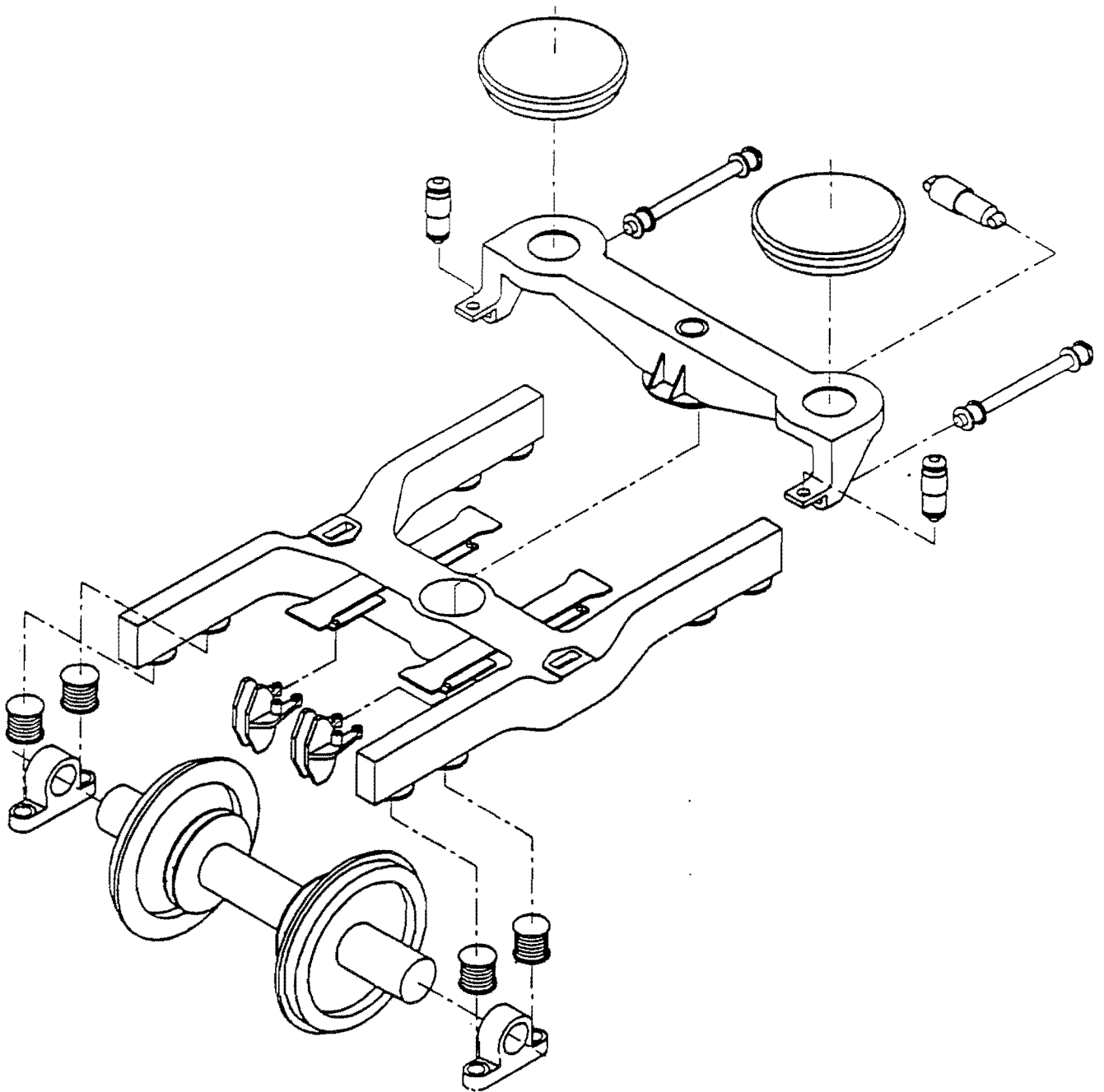


Figure A1.7.1 Nippon Sharyo NT319 Truck for Marc Commuter - Exploded View

A1.7: NIPPON SHARYO TRUCK FOR MARC II COMMUTER CAR (continued)

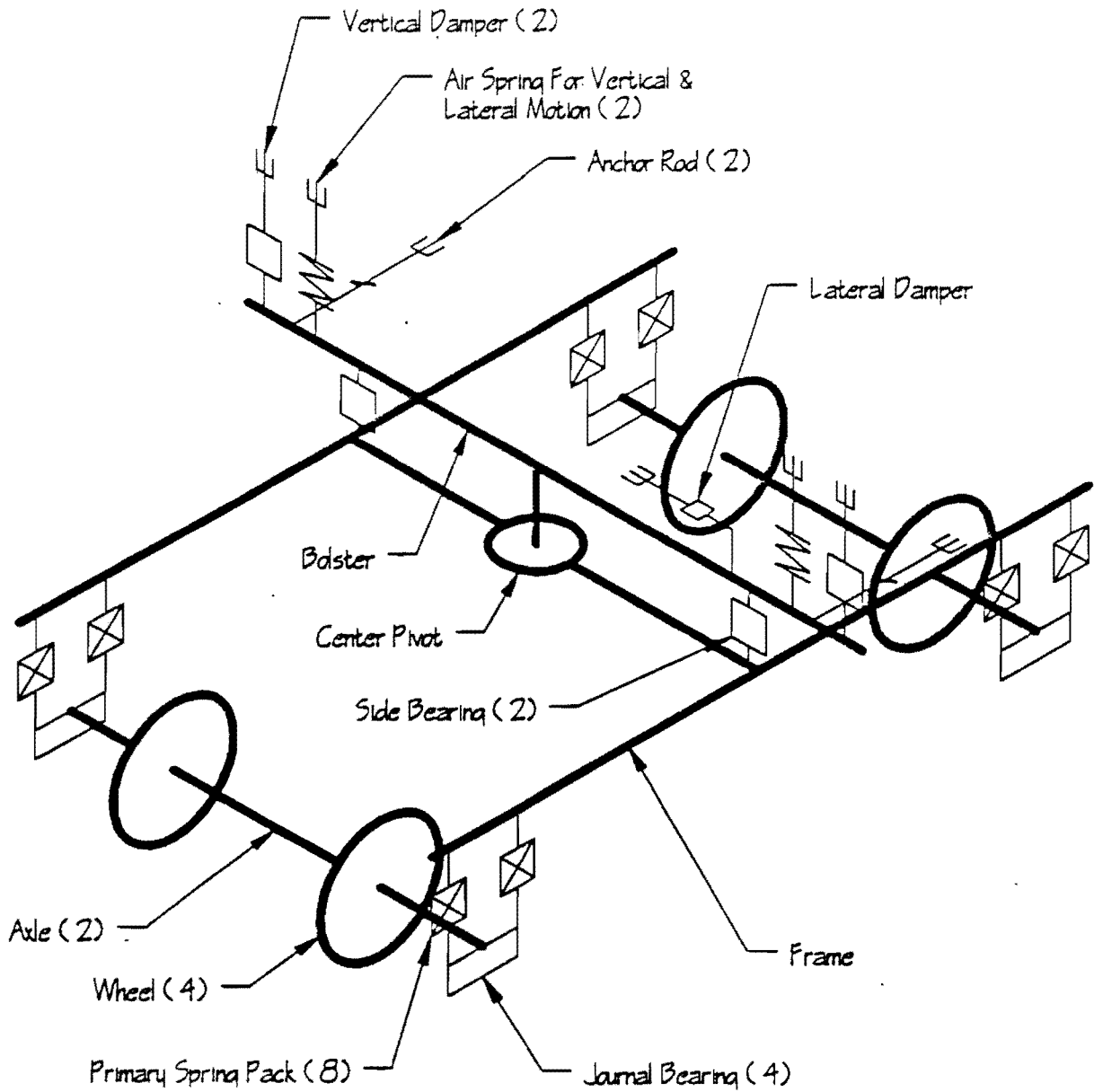


Figure A1.7.2 Nippon Sharyo NT319 Truck for Marc Commuter - Schematic

**A1.7: NIPPON SHARYO TRUCK FOR MARC II COMMUTER CAR  
(continued)**

**A1.7.1.2 Basic Truck Data**

Track Gauge	1435 mm (56.5 in)
Wheel Base	2500 mm (98.44 in)
Wheel Diameter	915 mm (36 in)
Bolster Bowl Diameter	Approx. 210 mm (8.25 in)
Truck Rotational Break Out Torque	Not Available
Design Load (Top of Bolster Bowl)	310 kN (68784 lb <sub>f</sub> )
Total Truck Weight	68.4 kN w/hand (15366 lb <sub>f</sub> ) brake
Brake Type	Two disc brakes per axle, single shoe tread brake unit per wheel.
Motor	None
Gear Box	None



### A1.7.1.3 Truck Center of Gravity, Mass and Moment of Inertia

Component Description	Number of Components	Mass of 1 Component kg (lb <sub>f</sub> sec <sup>2</sup> /in)	Center of Gravity Location mm (in)			Moment of Inertia kg-m <sup>2</sup> (lb <sub>f</sub> -in-sec <sup>2</sup> )		
			X	Y	Z	I <sub>xx</sub>	I <sub>yy</sub> *	I <sub>zz</sub>
Wheel & Axle Set	2	2358 (13.4)	1250.2 (49.22)	0.00	457.2 (18.0)	978 (8631)	0	978 (8631)
Truck Frame	1	1151.0 (6.57)	0.0	0.0	651.5 (24.47)	13.6 (12009)	11.1 (9783)	24.0 (21268)
Bolster	1	450.2 (2.57)	0.0	0.0	727.9 (28.66)	4.32 (3823)	0.14 (122)	4.4 (3869)
Equalizer Bar	---	---	---	---	---	---	---	---
Motor	---	---	---	---	---	---	---	---
Gear Box	---	---	---	---	---	---	---	---
Disc Brake Unit	4	*** 313 (1.78)	***	***	***	***	***	***
Primary Spring	4 sets	120.5 (0.69)	1250.2 (49.22)	1003 (39.5)	457.2 (18.0)	***	***	***
Secondary Vertical Damper	2	34.2 (0.195)	***	***	***	***	***	***
Secondary Lateral Damper	2	35.0 (0.2)	***	***	***	***	***	***
Anchor Rod	2	87.6 (0.5)	***	***	***	***	***	***
Air Spring Assembly	2	124.4 (0.71)	***	***	***	***	***	***

--- Not applicable to this truck, or value not relevant

\* Non-rotating components only for wheel and axle sets

\*\*\* Value required, but not available or estimated

**A1.7.1.4 Truck Suspension Parameters**

**A1.7.1.4.1 Primary Suspension**

Component	Stiffness N/mm (lb/in)			Damping Rates N sec/mm(lb <sub>f</sub> sec/in)			Clearance and Travel Tolerances mm (in)		
	Longi- tudinal	Lateral	Vertical	Longi- tudinal	Lateral	Vertical	Longi- tudinal	Lateral	Vertical
Individual Springs									
- Inside	---	---	---	---	---	---	---	---	---
- Outside	---	---	---	---	---	---	---	---	---
Double Coil Spring Set	***	***	***	---	---	***	***	***	***

--- Not applicable to this truck, or value not relevant

\*\*\* Value required, but not available or estimated

**A1.7.1.4.2 Secondary Suspension**

Component	Stiffness N/mm(lb <sub>f</sub> /in.)			Damping Rates N sec/mm(lb <sub>f</sub> sec/in.)		
	Longitudinal	Lateral	Vertical	Longitudinal	Lateral	Vertical
Air Spring	---	***	***	---	---	---
Lateral Bumper (Bolster/Car)	---	***	---	---	---	---
Vertical Shock Absorber	---	---	---	---	---	***
Lateral Shock Absorber	---	---	---	---	***	---
Center Pivot	---	---	---	---	---	---
Anchor Assembly	***	---	---	---	---	---

Component	Clearance & Travel Tolerances mm (in.)			Torque or Friction Force		
	Longitudinal	Lateral	Vertical	Longitudinal	Lateral	Vertical
Spring Side Bearing	---	---	***	***	---	---
Lateral Bumper (Bolster/Car)	---	***	---	---	---	---
Vertical Shock Absorber	---	---	***	---	---	---
Lateral Shock Absorber	---	***	---	---	---	---
Center Pivot	---	---	---	*** (rotational about vertical axis)		
Anchor Assembly	***	---	---	---	---	---

--- Not applicable to this truck or value not relevant

\*\*\* Value required, but not available or estimated

## **A1.7: NIPPON SHARYO TRUCK FOR MARC II COMMUTER CAR (continued)**

### **A1.7.1.5 Narrative Description of Load Path**

#### **A1.7.1.5.1 Longitudinal**

The longitudinal forces from the car body to the wheels originate with the anchor rod car support, through the anchor rod to the truck bolster, through the center pin to the truck frame, and then through the journal bearing housing.

#### **A1.7.1.5.2 Lateral**

The lateral load path is from the car body to the air springs, then to the truck bolster, to the center pin, to the truck frame and then to the journal bearing housings.

#### **A1.7.1.5.3 Vertical**

The vertical load path beginning at the car body will go through the two air springs, then to the truck bolster, then to the two side bearings to the frame and finally to the two separate coil spring assemblies that rest in the wing type journal bearing housings.

## **A1.7: NIPPON SHARYO TRUCK FOR MARC II COMMUTER CAR (continued)**

### **A1.7.2 Operating Environment and Operating Experience Data**

#### **A1.7.2.1 Background Information/Car Series**

Operator	Maryland Dept. of Transportation (MTA)
Type of Car	Commuter, single-level, unpowered
Name of Car Series	MARC II
Number in Service	64
Date(s) put into Service	1985 through 1993
Manufacturer of Car	NIPPON SHARYO
Type of Truck (Volpe/ADL Designation)	42e
Truck Manufacture and Model	NIPPON SHARYO NT 319

#### **A1.7.2.2 Operating and Route Data**

The MARC cars are used on commuter services in the Baltimore and Washington DC areas, both over the main line of the Northeast Corridor, and on the tracks of freight railroads. Services are operated with electric or diesel-electric locomotives in push-pull fashion with cab control cars. Maximum speeds are 160 km/h (100 mph) on the Northeast Corridor and 127 km/h (79 mph) on other lines.

Train Lengths Operated	Typically 4 to 8 cars
Braking Pattern (Friction/Dynamic) brakes	Typical of commuter service with stops every 3 to 10 miles, primarily using friction

## A1.7: NIPPON SHARYO TRUCK FOR MARC II COMMUTER CAR (continued)

### A1.7.2.3 Track System Data

#### FRA Track Class

- Main 4 (6 on Northeast Corridor)
- Sidings and Yard 1

Approximate Percentage of Welded & Jointed Rail 99% welded

Rail-Tie Fastener System Standard double/shouldered 14" tie plates, 3 spikes up to 2, 4 spikes over 2. Pandrol clips on concrete ties on the Northeast Corridor

#### Curvature Data

- Average/Typical Curvature on Main Track 2° 30'
- Maximum Curvature on Track 9°
- Approximate Percentage of Curved and Tangent Main Track 50% curved and 50% tangent
- Typical Spiral Length Relative to AREA Recommendations 40' per 1/2" elevation
- Typical Curvature in Yard and Siding Tracks 4°
- Maximum Curvature in Yards and Sidings 12°
- Typical Turnout Size (AREA Number)  
Main line  
Yard

**A1.7: NIPPON SHARYO TRUCK FOR MARC II COMMUTER CAR (continued)**

**A1.7.2.4 Maintenance and Service Experience**

Regular Servicing and Inspection  
Schedules

No information.

Rationale for Maintenance Schedules

Average or Typical Intervals  
(time or miles) between Maintenance  
Action or Component Replacement

Information on any Unusual  
Problems with Truck

- Information on the Maintainability  
of the Truck

Information on the Operator's  
Experience with the Truck

## A1.7: NIPPON SHARYO TRUCK FOR MARC II COMMUTER CAR (continued)

### A1.7.3. Engineering Data on Railroad Passenger Cars and Car-Truck Interface

#### A1.7.3.1 General Description of Car

The cars are single-level commuter coach cars designed by Tokyu Car for Maryland DOT and the Virginia Railway Express. Car body material is welded stainless steel. Some cars are equipped with a control cab for push-pull operation. Miscellaneous car equipment (HVAC, brake controls, etc.) are mounted under the car floor between the trucks.

#### Overall Dimensions

Length (over coupler faces)	25.91m (85.0 ft)
Width	3.20m (10.5 ft)
Height (from top of rail)	4.05m (13.3 ft)

Truck Center Spacing	18.13m (59.5 ft)
----------------------	------------------

#### Car Weight

- Ready to Run	
Cab Car	496 kN (111,000 lbf)
Trailer Car	454 kN (102,000 lbf)
With Maximum Load	
Cab Car	641 kN (144,000 lbf)
Trailer Car	600 kN (134,840 lbf)

#### Mass of Car Body (without trucks)

- Ready to Run	
Cab Car	36412 kg (2493 lbf-sec <sup>2</sup> /ft)
Trailer Car	32327 kg (2213 lbf-sec <sup>2</sup> /ft)

#### Radius of Gyration

Roll	1.6m (5.25 ft) (est)
Pitch	7.57m (24.8 ft) (est)
Yaw	7.57m (24.8 ft) (est)

Center of Gravity of Car Body	1.55m (5.1 ft) (est)
-------------------------------	----------------------

Car Body Natural Frequency (first vertical bending mode)	6.5 - 7.0 Hz (est)
---	--------------------



## A1.7: NIPPON SHARYO TRUCK FOR MARC II COMMUTER CAR (continued)

### A1.7.3.3 Car Body to Truck Interface

The car body rests on two air springs at each truck situated at the outer ends of the truck bolster. The longitudinal connection between the truck and the car body is by two laterally-spaced longitudinal anchor rods between the car body and truck bolster. Secondary vertical and lateral dampers (two of each) are also provided between the bolster and car body.

Specific dimensions are as follows:

Lateral spacing of airsprings	2.10m (6.9 ft ) (est)
Lateral spacing of secondary vertical dampers	2.64m (8.7 ft) (est)
Lateral spacing of anchor rods	2.66m (8.8 ft) (est)
Height of anchor rods above top of rail	0.50m (1.65 ft) (est)

## **A1.8: COMENG TRUCK FOR LIRR BI-LEVEL COMMUTER CAR**

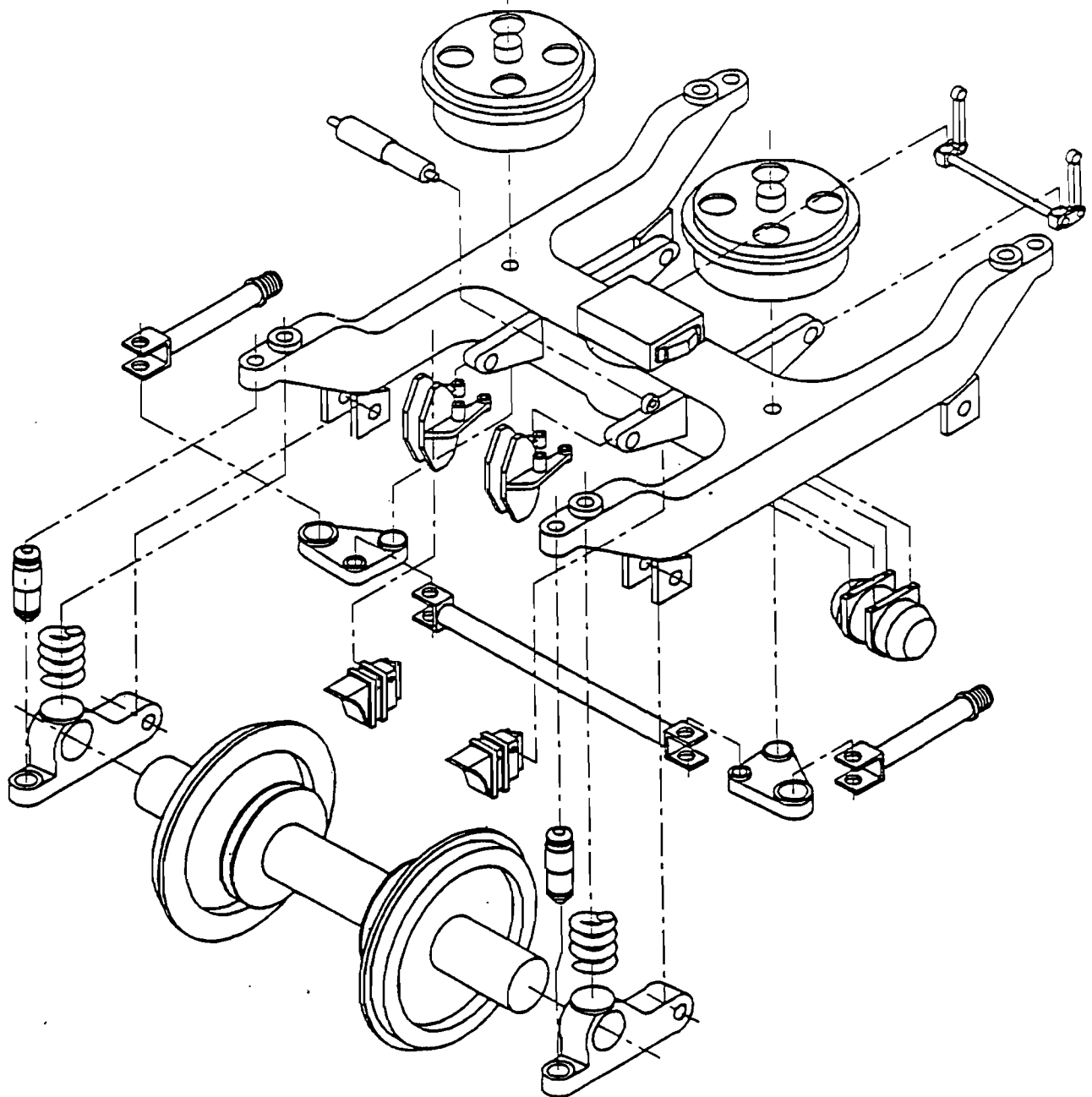
### **A1.8.1 Engineering Data**

#### **A1.8.1.1 Narrative Description of Truck Design**

Truck Classification	43e
General Characteristics	Bolsterless design with steering rod assembly.
Frame	Plate steel and casting in welded fabrication. Steering rod assembly used for car body connection is pivoted from underside of frame on both sides.
Suspension System	
– Primary	Swing arm type with soft coil springs. Four vertical dampers.
– Secondary	Air springs
Propulsion & Braking System	<ul style="list-style-type: none"><li>– No propulsion</li><li>– Disc brake, WABCO 26C-C52</li><li>– Tread brake, WABCO GAB-D, COBRA shoe, one per wheel.</li></ul>

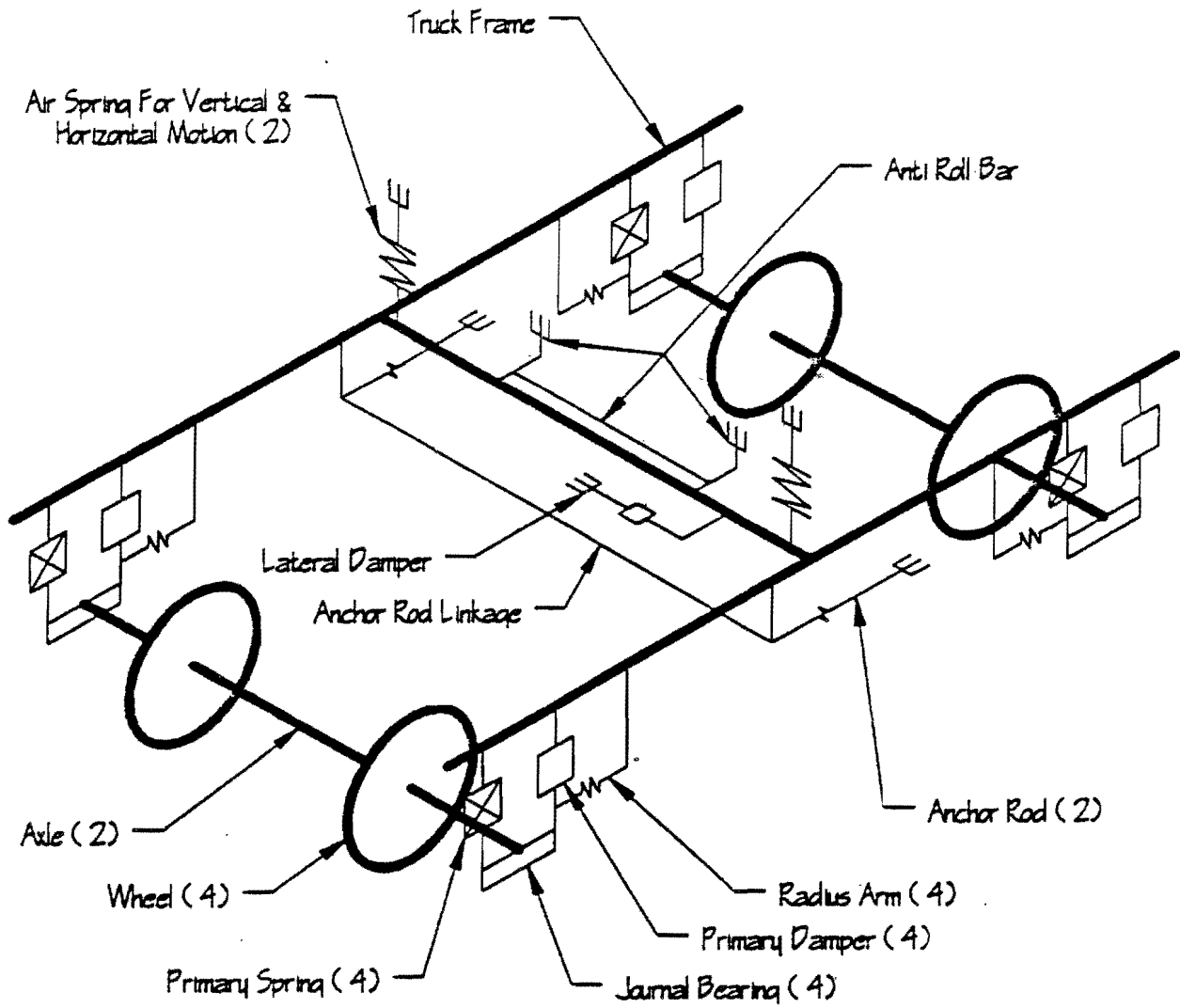
Exploded engineering and schematic drawings of this truck are provided in Figures A1.8.1 and A1.8.2.

**A1.8: COMENG TRUCK FOR LIRR BI-LEVEL COMMUTER CAR (continued)**



**Figure A1.8.1 Comeng Truck for Long Island RR Tokyu Car Bi-Level  
Commuter Car - Exploded View**

**A1.8: COMENG TRUCK FOR LIRR BI-LEVEL COMMUTER CAR (continued)**



**Figure A1.8.2 Comeng Truck for Long Island RR Tokyu Car Bi-Level Commuter Car - Schematic**

## **A1.8: COMENG TRUCK FOR LIRR BI-LEVEL COMMUTER CAR (continued)**

### **A1.8.1.2 Basic Truck Data**

Track Gauge	1435 mm (56.5 in)
Wheel Base	2438 mm (96 in)
Wheel Diameter	914 mm (36 in)
Bolster Bowl Diameter	None
Truck Rotational Break Out Torque	Not Applicable
Design Load (On Air Springs)	734 kN (165,000 lbf) (est)
Total Truck Weight	45.4 kN (10,200 lbf)
Brake Type	WABCO Disc WABCO Tread
Motor	None
Gear Box	None

### A1.8.1.3 Truck Center of Gravity, Mass and Moment of Inertia

Component Description	Number of Components	Mass of 1 Component kg (lb <sub>r</sub> sec <sup>2</sup> /in)	Center of Gravity Location mm (in)			Moment of Inertia kg-m <sup>2</sup> (lb <sub>r</sub> in-sec <sup>2</sup> )		
			X	Y	Z	I <sub>xx</sub>	I <sub>yy</sub> *	I <sub>zz</sub>
Wheel & Axle Set	1	1870 (10.7)	1219.2 (48.00)	0.00	457.2 (18.0)	733 (6487)	0.05 (47)	733 (6487)
Truck Frame	1	1138.0 (6.5)	0.0	0.0	726.9 (28.62)	17.8 (15733)	9.8 (8577)	27.0 (23874)
Bolster	---	---	---	---	---	---	---	---
Equalizer Bar	---	---	---	---	---	---	---	---
Motor	---	---	---	---	---	---	---	---
Gear Box	---	---	---	---	---	---	---	---
Tread Brake Unit	4	62.4	***	***	***	***	***	***
Disc Brake	4	313 (1.78)	***	***	***	***	***	***
Primary Spring	4	44 (0.26)	***	***	***	***	***	***
Primary Damper	4	43.3 (0.25)	***	***	***	***	***	***
Secondary Vertical Damper	2	---	---	---	---	---	---	---
Secondary Lateral Damper	2	35.0 (0.20)	***	***	***	***	***	***
Anchor Rod	2	0	***	***	***	***	***	***
Air Spring Assembly	2	86.1 (0.49)	***	***	***	***	***	***

--- Not applicable to this truck, or value not relevant

\*\*\* Value required, but not available as estimated

\* Non-rotating parts only for wheel and axle sets

**A1.8.1.4 Truck Suspension Parameters**

**A1.8.1.4.1 Primary Suspension**

Component	Stiffness N/mm (lb/in)			Damping Rates N sec/mm(lb <sub>f</sub> sec/in)			Clearance and Travel Tolerances mm (in)		
	Longi- tudinal	Lateral	Vertical	Longi- tudinal	Lateral	Vertical	Longi- tudinal	Lateral	Vertical
Individual Spring Damper Unit									
- Inside	---	---	---	---	---	---	---	---	---
- Outside	***	***	***	---	---	***	---	---	***
Double Coil Spring Set	---	---	---	---	---	---	---	---	---
Radium Arm	***	***	---	---	---	---	***	***	---

--- Not applicable to this truck, or value not relevant

\*\*\* Value required, but not available or estimated

A1-97

A1.8: COMENG TRUCK FOR LIRR BI-LEVEL COMMUTER CAR (continued)

**A1.8.1.4.2 Secondary Suspension**

Component	Stiffness N/mm(lb <sub>f</sub> /in.)			Damping Rates N sec/mm(lb <sub>f</sub> sec/in.)		
	Longitudinal	Lateral	Vertical	Longitudinal	Lateral	Vertical
Air Spring	***	***	***	---	---	***
Lateral Bumper (Bolster/Car)	---	***	---	---	---	---
Vertical Shock Absorber	---	---	---	---	---	---
Lateral Shock Absorber	---	---	---	---	***	---
Center Pivot	---	---	---	---	---	---
Anchor Assembly	---	---	---	---	---	---

Component	Clearance & Travel Tolerances mm (in.)			Torque or Friction Force		
	Longitudinal	Lateral	Vertical	Longitudinal	Lateral	Vertical
Spring	***	***	***	---	---	---
Lateral Bumper (Bolster/Car)	---	50.8 (2)	---	---	---	---
Vertical Shock Absorber	---	---	***	---	---	---
Lateral Shock Absorber	---	***	---	---	---	---
Center Pivot	---	---	---	---	---	---
Anchor Assembly	---	---	---	---	---	---

--- Not applicable to this truck, or value not relevant

\*\*\* Value required, but not available or estimated

A1-98

A1.8: COMING TRUCK FOR LIRR BI-LEVEL COMMUTER CAR (continued)



## **A1.8: COMENG TRUCK FOR LIRR BI-LEVEL COMMUTER CAR (continued)**

### **A1.8.1.5 Narrative Description of Load Path**

#### **A1.8.1.5.1 Longitudinal**

Longitudinal load path from car body to steering rod assembly, to truck frame, to swing arm assembly, to journal bearing housing.

#### **A1.8.1.5.2 Lateral**

Lateral load path is through the air springs, to the truck frame to the swing arm assembly, to the journal bearing housings.

#### **A1.8.1.5.3 Vertical**

The vertical load path is from the car body to the air springs, to the truck frame, to the primary springs, to the journal bearing housing.

### **A1.8.1.6 Wheel Profile Drawing**

AAR standard, narrow flange, B-36.

**A1.8: COMENG TRUCK FOR LIRR BI-LEVEL COMMUTER CAR (continued)**

**A1.8.2 Operating Environment and Operating Experience Data**

**A1.8.2.1 Background Information/Car Series**

Operator	Long Island RR
Type of Car	Commuter, bi-level, unpowered
Name of Car Series	C-1 Push Pull
Number in Service	10
Date(s) put into Service	1990
Manufacturer of Car	Tokyu Car
Type of Truck (Volpe/ADL Designation)	43e
Truck Manufacture and Model	Comeng (Australia) TS-1008

**A1.8.2.2 Operating and Route Data**

The car is operated on the longer distance diesel-electric locomotive powered services of the Long Island Railroad. Journey lengths can be up to approximately 100 miles with maximum operating speeds normally up to 79 mph.

Train Lengths Operated	Up to 12 cars
Braking Patterns (Friction/Dynamic)	Typical of longer distance commuter operation, with stops at 5-10 mile intervals, depending on specific service. Primarily friction braking with some dynamic braking assistance from diesel-electric locomotive.

## **A1.8: COMENG TRUCK FOR LIRR BI-LEVEL COMMUTER CAR (continued)**

### **A1.8.2.3 Track System Data**

#### **FRA Track Class**

- Main LIRR non electrified system, no other information available.
  
- Sidings and Yard

#### **Approximate Percentage of Welded & Jointed Rail**

#### **Rail-Tie Fastener System**

#### **Curvature Data**

- Average/Typical Curvature on Main Track
  
- Maximum Curvature on Track
  
- Approximate Percentage of Curved and Tangent Main Track
  
- Typical Spiral Length Relative to AREA Recommendations
  
- Typical Curve Radius in Yard and Siding Tracks
  
- Minimum Curve Radius in Yards and Sidings
  
- Typical Turnout Size (Area Number)  
Main line  
Yard

**A1.8: COMENG TRUCK FOR LIRR BI-LEVEL COMMUTER CAR (continued)**

**A1.8.2.4 Maintenance and Service Experience**

Regular Servicing and Inspection  
Schedules

No information available.

Rationale for Maintenance Schedules

Average or Typical Intervals  
(time or miles) between Maintenance  
Action or Component Replacement

Information on any Unusual  
Problems with Truck

Information on the Maintainability  
of the Truck

Information on the Operator's  
Experience with the Truck

## **A1.8: COMENG TRUCK FOR LIRR BI-LEVEL COMMUTER CAR (continued)**

### **A1.8.3 Engineering Data on Railroad Passenger Cars and Car-Truck Interface**

#### **A1.8.3.1 General Description of Car**

The car is a bi-level commuter coach car designed by Tokyu Car. The car body material is stainless steel. Two seating levels are provided between the trucks, with a single-level area with a conventional floor height over the trucks. The car ends contain an entry vestibule and additional seating. Car equipment (HVAC units, water tanks, etc.) are contained in the rear space at the ends of the car.

#### **A1.8.3.2 Car and Car Body Data**

##### **Overall Dimensions**

- Length (over coupler faces) 25.04m (82.2 ft)
- Width 3.05m (10.0 ft)
- Height (from top of rail) 4.42m (14.5 ft)

##### **Truck Center Spacing**

18.13m (59.5 ft)

##### **Car Weight**

- Ready to Run 589 kN (132,500 lbf)
- With Maximum Load 721 kN (161,822 lbf)

##### **Mass of Car Body (without trucks) (ready to run)**

50848 kg (3481 lbf-sec<sup>2</sup>/ft)

##### **Radius of Gyration**

- Roll 1.62m (5.4 ft) (est)
- Pitch 7.50m (24.6ft) (est)
- Yaw 7.50m (24.6 ft) (est)

##### **Center of Gravity of Car Body (from top of rail)**

1.8m (5.9 ft)

##### **Car Body Natural Frequency (first vertical bending mode)**

7.0 -7.5 Hz

## A1.8: COMENG TRUCK FOR LIRR BI-LEVEL COMMUTER CAR (continued)

### A1.8.3.3 Car Body to Truck Interface

The car body rests on two combination air springs which in turn rest directly on the truck side frame. No bolster is used. Longitudinal connection is via two laterally spaced anchor rods attached to bell cranks mounted beneath the truck side frames with a lateral tie bar between the bell cranks. This mechanism permits truck swivelling but provides a longitudinal connection. Other truck frame to car body connections are from an anti-roll torsion bar and two lateral dampers.

Approximate dimensions are:

Lateral spacing of air springs	1.80m (5.9ft)
Lateral spacing of anchor rods	2.60m (8.5 ft)
Height of anchor rods above top of rail	0.46m (1.5 ft)

## APPENDIX 2

### PASSENGER CAR POPULATION DATA

#### A2.1 Introduction

The two tables in this appendix list all railroad passenger cars in operation in the United States. The effective date of the data in the table is approximately the beginning of 1994, and reflects information available in early 1994. The data also includes some cars on order but not delivered in early 1994. There is typically a time lapse of one to two years between an order being placed for a series of railroad passenger cars, and the delivery of the first car from the manufacturer.

It should be noted that the fleets of passenger rail service operators are constantly changing, with older cars being retired or sold and new or secondhand cars being purchased. Any list such as those in Tables A2-1 and A2-2 will gradually become out of date.

The U.S. population of railroad passenger cars is presented in two ways. Table A2-1 lists all individual car series by operator, in the rough order of age, starting with the oldest cars within each operator's fleet. Table A2-2 lists the individual car series by truck classification, also in rough order of age, starting with the oldest cars within each truck classification. The truck classification table distinguishes between powered and unpowered trucks.

Generally, a car series is a group of cars of a single design, built at the same time under one order from the manufacturer. In the case of older cars, several series of similar design have been grouped under one entry in the table, for example Amtrak's heritage single-level passenger cars which were supplied to the predecessor railroads over a period of time. Also, a car series can include cars with detail differences in the car body and interior appointments. Many commuter car series include both cab cars and trailer cars. Intercity car series can include diners, sleepers, and coaches. The practical difference from the point of view of car dynamics is that there can be weight variations up to about 10 percent between the lightest and heaviest car in a series.

The specific information provided in the tables is as follows:

- Car series designation, generally the initials or an abbreviation of the car owner or operator, followed by a number.
- The formal owner of the car series, which is sometimes a different entity from the operator.
- The contract operator of the service, if different from the owner. Amtrak operates several commuter services for local government agencies, and in Chicago some freight railroads, notably Chicago and North Western and Burlington Northern, operate commuter services under contract.
- The name of the car series, if used.
- The car manufacturer.
- The number of cars in service.

- The dates between which the cars were originally built. Rebuilding dates, if applicable, are not given.
- Whether the car is unpowered, or a powered car used in electric or gas turbine self-propelled trainsets.
- The body style of the car, specifically whether single or bi-level.
- Typical maximum speed of operation in units of km/h and mph.
- Approximate total car weight in units of kg and lb. The weights are for a fully equipped but empty car. Typically there will be weight variations within a series of the order of  $\pm 5\%$  due to different passenger accommodation arrangements or the provisions of a control cab.
- Truck manufacturer and model.
- Truck classification, as given in Section 3.2 of this report.

A comments column is also provided under both car and truck descriptions for further relevant information.



Table A2-1 Passenger Car Population Data by Operator  
 [Effective Date Approximately 1/1/94]

Car	Contract	Type	Series	Number	Dates	Powered or	Car Description	Truck Description								
Series	Owner	Operator	of	Name	Manufacturer	In	Put into	Powered or	Body	Typical Max	Approximate	Comments	Manufacturer	Model	Classification	Comments
Designation	(If Different)	Operation	(Where Used)	Service	Service	Unpowered	Type	Speed	Total Weight (Empty)	kn/h (mph)	kg (lb)					
<b>National Passenger Railroad Corporation</b>																
AMTK 1	Amtrak		Intercity	Heritage	Mostly Budd	299	1948-58	Unpowered	Single-Level Coach	177 (110)	63500 (140000)	Coaches, Diners and Sleepers	GSI	Traditional	31e	
AMTK 2	Amtrak		Intercity	Santa Fe Hi-Level	Budd	95	1954-63	Unpowered	Full Bi-Level	177 (110)	72500 (160000)	Coaches, Diners and Sleepers	GSI	Traditional	31e	
AMTK 3	Amtrak		Intercity	Capitoliner	Budd	62	1967-69	Unpowered	Single-Level Coach	177 (110)	59000 (130000)	Coaches	Budd	Pioneer III	21i	
AMTK 4	Amtrak		Intercity	Amfleet I	Budd	474	1975-77	Unpowered	Single-Level Coach	201 (125)	50000 (110000)	Coaches and Food Service Cars	Budd	Pioneer III	21i	
AMTK 5	Amtrak		Intercity	Superliner Bi-Level	Pullman Standard	282	1979-81	Unpowered	Full Bi-Level	177 (110)	70000 (155000)	Coaches, Diners and Sleepers	Waggon Union	MD 76	41e	Wt 8250 kg (18187lb)
AMTK 6	Amtrak		Intercity	Amfleet II	Budd	148	1979-80	Unpowered	Single-Level Coach	201 (125)	50000 (110000)	Coaches and Food Service Cars	Budd	Pioneer III	21i	
AMTK 7	Amtrak		Intercity	Turbo Power Car	Rohr/ANF	18	1975-77	Powered	Single-Level Coach	177 (110)		Gas Turbine and Electric 3rd Rail	ANF		43e-P2	
AMTK 8	Amtrak		Intercity	Turbo Coach/Snack	Rohr/ANF	27	1975-77	Unpowered	Single-Level Coach	177 (110)		Coaches and Food Service Cars	ANF		43e	
AMTK 9	Amtrak		Intercity	Horizon	Bombardier	103	1989-90	Unpowered	Single-Level Coach	201 (125)	53000 (116000)	Coaches and Food Service Cars	GSI	General 70	32e	Outside Frame
AMTK 10	Amtrak		Intercity	Superliner II Bi-Level	Bombardier	128	1993-94	Unpowered	Full Bi-Level	177 (110)	70000 (155000)	Coaches, Diners and Sleepers	GSI	General 70	32e	Outside Frame
AMTK 11	Amtrak		Intercity	Viewliner	Morrison Knudsen	50	1993-94	Unpowered	Single-Level Coach	177 (110)		Coaches, Diners and Sleepers	GSI	General 70	32e	Outside Frame
					Total	1686										
<b>California Department of Transportation</b>																
CDOT 1	California DOT		Intercity	California car	Morrison Knudsen	40	1994	Unpowered	Full Bi-Level	201 (125)	63500 (140000)	Includes Cab Cars	GSI	General 70	32e	Outside Frame
					Total	40										
<b>Maryland Department of Transportation, Mass Transit Administration</b>																
MDOT 1	Maryland DOT	Amtrak	Commuter		Budd	44	1955	Unpowered	Single-Level Coach	127 (79)	54500 (120000)	Coaches Only	GSI	Traditional	31e	
MDOT 2	Maryland DOT	Amtrak	Commuter		Nippon Sharyo	64	1985-91	Unpowered	Single-Level Coach	177 (110)	50000 (111000)	Includes Cab Cars	Nippon Sharyo	NT 319	42e	Wt 6970 kg (15366 lb)
MDOT 3	Maryland DOT	Amtrak	Commuter		Sumitomo	11	1992-93	Unpowered	Single-Level Coach	177 (110)	50000 (111000)	Includes Cab Cars	Nippon Sharyo	NT 319	42e	Wt 6970 kg (15366 lb)
					Total	119										
<b>Massachusetts Bay Transportation Authority</b>																
MBTA 1	MBTA	Amtrak	Commuter		Pullman Standard	57	1979	Unpowered	Single-Level Coach	129 (80)	43000 (95000)	Includes Cab Cars	GSI	General 70	32i	Inside Frame
MBTA 2	MBTA	Amtrak	Commuter		MBT	67	1987-88	Unpowered	Single-Level Coach	129 (80)	43000 (95000)	Includes Cab Cars	GSI	General 70	32i	Inside Frame
MBTA 3	MBTA	Amtrak	Commuter		Bombardier	147	1987-90	Unpowered	Single-Level Coach	129 (80)	43000 (95000)	Includes Cab Cars	GSI	General 70	32i	Inside Frame
MBTA 4	MBTA	Amtrak	Commuter		Kawasaki	75	1993-94	Unpowered	Single-Level Coach	129 (80)	56000 (123500)	Includes Cab Cars	Kawasaki		42e	Outside Frame
					Total	346										
<b>Chicago Commuter Rail Service Board</b>																
METRA 1	Chicago	METRA, BN, CNW	Commuter		Various	464	1950-70	Unpowered	Gallery Bi-Level Coach	121 (75)	59000 (130000)	Includes Cab Cars	GSI	Traditional	32e	Outside Frame
METRA 2	Chicago	METRA, BN, CNW	Commuter		St. Louis Car	129	1971-72	Powered	Gallery Bi-Level MU Coach	121 (75)	63500 (140000)	Overhead Catenary	GSI	General 70	32e-P2	Outside Frame, Powered
METRA 3	Chicago	METRA, BN, CNW	Commuter		Budd	66	1973-74	Unpowered	Gallery Bi-Level Coach	121 (75)	59000 (130000)	Includes Cab Cars	GSI	General 70	32e	Outside Frame
METRA 4	Chicago	METRA, BN, CNW	Commuter		Budd	104	1978-79	Unpowered	Gallery Bi-Level Coach	121 (75)	59000 (130000)	Includes Cab Cars	GSI	General 70	32e	Outside Frame
METRA 5	Chicago	METRA, BN, CNW	Commuter		Budd	50	1980	Unpowered	Gallery Bi-Level Coach	121 (75)	59000 (130000)	Includes Cab Cars	GSI	General 70	32e	Outside Frame
METRA 6	Chicago	METRA, BN, CNW	Commuter		Bombardier	36	1978-79	Powered	Gallery Bi-Level MU Coach	121 (75)	63500 (140000)	Overhead Catenary	GSI	General 70	32e-P2	Outside Frame, Powered
METRA 7	Chicago	METRA, BN, CNW	Commuter		Morrison Knudsen	173	1993-94	Unpowered	Gallery Bi-Level Coach	121 (75)	59000 (130000)	Includes Cab Cars	Atcheson		42i	Dofasco Design
					Total	1022										
<b>Northern Indiana Commuter Transportation District</b>																
NICTD 1	NICTD		Commuter		Sumitomo	41	1982-83	Powered	Single-Level MU Coach	121 (75)	48500 (107000)	Overhead Catenary	Nippon Sharyo	ND 312	42e-P2	
NICTD 2	NICTD		Commuter		Sumitomo	17	1992	Powered	Single-Level MU Coach	121 (75)	48500 (107000)	Overhead Catenary	Nippon Sharyo	ND 312	42e-P2	
					Total	58										
<b>Southern California Regional Rail Authority</b>																
SCRRA 1	SCRRA	Amtrak	Commuter	Series V	UTDC Canada	63	1992	Unpowered	Lozenge Style Bi-Level	135 (84)	51000 (113000)	Includes Cab Cars	Dofasco		42i	
SCRRA 2	SCRRA	Amtrak	Commuter	Series V	Bombardier	43	1994	Unpowered	Lozenge Style Bi-Level	135 (84)	51000 (113000)	Includes Cab Cars	Dofasco		42i	
					Total	106										
Note: The SCRRA total includes 8 identical cars owned by North San Diego County Transit District, and 4 identical cars owned by Orange County Transportation Authority.																

100

Table A2-1 Passenger Car Population Data by Operator (continued)  
[Effective Date Approximately 1/1/94]

Car Series	Owner	Contract Operator	Type of Operation	Series Name (Where Used)	Manufacturer	Number in Service	Dates Put Into Service	Powered or Unpowered	Body Type	Car Description			Truck Description			
										Typical Max Speed	Approximate Total Weight (Empty)	Comments	Manufacturer	Model	Classification	Comments
Designation		(If Different)								km/h (mph)	kg (lb)					
<b>Tri-County Commuter Rail Authority</b>																
TRI1	TCORA		Commuter	Series III	UTDC Canada	18	1992	Unpowered	Lozenge Style Bi-Level	135 (84)	51000 (113000)	Includes Cab Cars	Dofasco		42i	
TRI2	TCORA		Commuter	Series V	UTDC Canada	3	1994	Unpowered	Lozenge Style Bi-Level	135 (84)	51000 (113000)	Includes Cab Cars	Dofasco		42i	
					Total	21										
<b>Long Island Railroad</b>																
LRR1	NYMTA	LRR	Commuter		Pullman Standard	189	1955-63	Unpowered	Single-Level Coach		54500 (120000)	Coaches Only	GSI	Traditional	31e	
LRR2	NYMTA	LRR	Commuter	M1 MU Coach	Budd	510	1968-71	Powered	Single-Level M/J Coach		50000 (110000)	3rd Rail 750V DC Electrification	Budd	Pioneer III	21i-P2	Powered Inside Frame
LRR3	NYMTA	LRR	Commuter	M1 MU Coach	General Electric	148	1972	Powered	Single-Level M/J Coach		50000 (110000)	3rd Rail 750V DC Electrification	Budd	Pioneer III	21i-P2	Powered Inside Frame
LRR4	NYMTA	LRR	Commuter	M3 MU Coach	Budd	174	1985	Powered	Single-Level M/J Coach		50000 (110000)	3rd Rail 750V DC Electrification	GSI	General 70	32i-P2	Powered Inside Frame
LRR5	NYMTA	LRR	Commuter	C1 MU Coach	Tokyu Car	10	1990	Powered	Bi-Level MU Coach		56000 (124000)	3rd Rail 750V DC Electrification	Comeng (Design)		43e	Fabricated, Bolsterless
					Total	1031										
<b>Metro North Commuter Railroad</b>																
MNCR1	NYMTA	MNCR	Commuter		Pullman Standard	61	1962	Powered	Single-Level M/J Coach	145 (90)	54000 (120000)	11.5 kv AC Overhead + DC 3rd Rail	GSI	Traditional	31e-P2	
MNCR2	NYMTA	MNCR	Commuter	M1A MU Coach	Budd	178	1971	Powered	Single-Level M/J Coach	145 (90)	50000 (110000)	750v 3rd Rail DC Electric	GSI	Pioneer III	21i-P2	Powered Inside Frame
MNCR3	NYMTA	MNCR	Commuter	M2 MU Coach	General Electric	242	1973	Powered	Single-Level M/J Coach	145 (90)	50000 (110000)	11.5 kv AC Overhead + DC 3rd Rail	GSI	General 70	32i-P2	Powered Inside Frame
MNCR4	NYMTA	MNCR	Commuter	M3A MU Coach	Budd	142	1984	Powered	Single-Level M/J Coach	145 (90)	50000 (110000)	750v 3rd Rail DC Electric	GSI	General 70	32i-P2	Powered Inside Frame
MNCR5	NYMTA	MNCR	Commuter		Bombardier	60	1986	Unpowered	Single-Level Coach	145 (90)	40000 (88000)	Includes Cab Cars	GSI	General 70	32i	Inside Frame
MNCR6	NYMTA	MNCR	Commuter	M4 MU Coach	Tokyu Car	54	1988	Powered	Single-Level M/J Coach	145 (90)	50000 (110000)	11.5 kv AC Overhead + DC 3rd Rail	Tokyu Car		42i-P2	Fabricated, Inside Frame
MNCR7	NYMTA	MNCR	Commuter		Bombardier	18	1991	Unpowered	Single-Level Coach	145 (90)	40000 (88000)	Includes Cab Cars	GSI	General 70	32i	Inside Frame
MNCR8	NYMTA	MNCR	Commuter	M6 MU Coach	Morrison Knudsen	48	1993-94	Powered	Single-Level M/J Coach	145 (90)	50000 (110000)	11.5 kv AC Overhead + DC 3rd Rail	GSI	General 70	32i-P2	Powered Inside Frame
					Total	803										
<b>New Jersey Transit</b>																
NJT1	NJT		Commuter	Comet IB	St Louis Car	30	1968	Unpowered	Single-Level Coach	129 (80)	41000 (90000)	Includes Cab Cars	GSI	General 70	32i	Inside Frame
NJT2	NJT		Commuter	Comet I	Pullman Standard	147	1971	Unpowered	Single-Level Coach	129 (80)	41000 (90000)	Includes Cab Cars	GSI	General 70	32i	Inside Frame
NJT3	NJT		Commuter	Arrow II MU Coach	General Electric	70	1974-75	Powered	Single-Level MU Coach	160 (100)	50000 (110000)	11.5 kv Overhead Electric	GSI	General 70	32i-P2	Powered Inside Frame
NJT4	NJT		Commuter	Arrow III MU Coach	General Electric	230	1977-78	Powered	Single-Level MU Coach	160 (100)	50000 (110000)	11.5 kv Overhead Electric	GSI	General 70	32i-P2	Powered Inside Frame
NJT5	NJT		Commuter	Comet II and IIA Coach	Bombardier	132	1982-83	Unpowered	Single-Level Coach	129 (80)	41000 (90000)	Includes Cab Cars	GSI	General 70	32i	Inside Frame
NJT6	NJT		Commuter	Comet IIB Coach	Bombardier	52	1987-88	Unpowered	Single-Level Coach	129 (80)	41000 (90000)	Includes Cab Cars	GSI	General 70	32i	Inside Frame
NJT7	NJT		Commuter	Comet III Coach	Bombardier	5	1990-91	Unpowered	Single-Level Coach	129 (80)	41000 (90000)	Includes Cab Cars	GSI	General 70	32i	Inside Frame
					Total	666										
<b>Southeastern Pennsylvania Transportation Authority</b>																
SEPTA1	SEPTA		Commuter	Silverliner II MU Coach	Budd	53	1963-64	Powered	Single-Level MU Coach		50000 (110000)	11.5 kv Overhead Electric	GSI	General 70	32i-P2	Powered Inside Frame
SEPTA2	SEPTA		Commuter	Silverliner III MU Coach	St Louis Car	20	1967	Powered	Single-Level MU Coach		50000 (110000)	11.5 kv Overhead Electric	GSI	General 70	32i-P2	Powered Inside Frame
SEPTA3	SEPTA		Commuter	Silverliner IV MU Coach	General Electric	231	1973-77	Powered	Single-Level MU Coach		50000 (110000)	11.5 kv Overhead Electric	GSI	General 70	32i-P2	Powered Inside Frame
SEPTA4	SEPTA		Commuter		Bombardier	35	1987	Unpowered	Single-Level Coach	129 (80)	42000 (92000)	Includes Cab Cars	GSI	General 70	32i	Inside Frame
					Total	339										
<b>Peninsular Corridor Joint Powers Board (San Francisco)</b>																
SANF1	PCJPB	Amtrak	Commuter		Sumitomo/Nippon Sharyo	73	1985-1987	Unpowered	Bi-level Coach	121 (75)	59000 (130000)	Includes Cab Cars	GSI	Traditional	31e	Recycled Trad., Anti Roll Bar
SANF2	PCJPB	Amtrak	Commuter	California Coach	Morrison Knudsen	23	1993	Unpowered	Bi-level Coach	121 (75)	63500 (140000)	Includes Cab Cars	GSI	General 70	32e	Outside Frame
					Total	96										
<b>Virginia Railway Express</b>																
VRE1	VRE	Amtrak	Commuter		Budd	21	1955	Unpowered	Single-Level Coach		48000 (106000)	Ex Boston RDC's	GSI	Traditional	31e	
VRE2	VRE	Amtrak	Commuter		Morrison Knudsen	38	1992	Unpowered	Single-Level Coach		48000 (106000)	Includes Cab Cars	Tokyu Car	NT319	42e	Fabricated, Outside Frame
					Total	59										
					<b>Grand Total</b>	<b>6392</b>										



**Table A2-2 Passenger Car Population Data by Truck Classification**  
 [Effective Date Approximately 1/1/94]

Car Series	Owner	Contract Operator (If Different)	Type of Operation	Series Name (Where Used)	Manufacturer	Number In Service	Dates Put Into Service	Powered or Unpowered	Body Type	Car Description		Comments	Truck Description			
										Typical Max Speed km/h (mph)	Approximate Total Weight (Empty) kg (lb)		Manufacturer	Model	Classification	Comments
<b>Type 21i: Articulated Frame with Center Pivot, Unpowered</b>																
AMTK 3	Amtrak		Intercity	Capitoliner	Budd	62	1967-69	Unpowered	Single-Level Coach	177 (110)	59000 (130000)	Coaches	Budd	Pioneer III	21i	
AMTK 4	Amtrak		Intercity	Amfleet I	Budd	474	1975-77	Unpowered	Single-Level Coach	201 (125)	50000 (110000)	Coaches and Food Service Cars	Budd	Pioneer III	21i	
AMTK 6	Amtrak		Intercity	Amfleet II	Budd	148	1979-80	Unpowered	Single-Level Coach	201 (125)	50000 (110000)	Coaches and Food Service Cars	Budd	Pioneer III	21i	
						Total										
<b>Type 21i-P2: Articulated Frame with Center Pivot, Powered</b>																
LRR 2	NYMTA	LRR	Commuter	M1 MU Coach	Budd	510	1968-71	Powered	Single-Level MU Coach		50000 (110000)	3rd Rail 750V DC Electrification	Budd	Pioneer III	21i-P2	Powered Inside Frame
LRR 3	NYMTA	LRR	Commuter	M1 MU Coach	General Electric	148	1972	Powered	Single-Level MU Coach		50000 (110000)	3rd Rail 750V DC Electrification	Budd	Pioneer III	21i-P2	Powered Inside Frame
MNCR 2	NYMTA	MNCR	Commuter	M1A MU Coach	Budd	178	1971	Powered	Single-Level MU Coach		50000 (110000)	750v 3rd Rail DC Electric	GSI	Pioneer III	21i-P2	Powered Inside Frame
						Total										
<b>Type 31e: Traditional GSI with Equalizer Beam Primary, Bearings Outside Wheels, and Swinghanger Secondary, Unpowered</b>																
AMTK 1	Amtrak		Intercity	Heritage	Mostly Budd	299	1948-58	Unpowered	Single-Level Coach	177 (110)	63500 (140000)	Coaches, Diners and Sleepers	GSI	Traditional	31e	
AMTK 2	Amtrak		Intercity	Santa Fe Hi-Level	Budd	95	1954-63	Unpowered	Full Bi-level	177 (110)	72500 (160000)	Coaches, Diners and Sleepers	GSI	Traditional	31e	
METRA 1	Chicago	METRA, BN, CNW	Commuter		Various	464	1950-70	Unpowered	Gallery Bi-Level Coach		59000 (130000)	Includes Cab Cars	GSI	Traditional	31e	Outside Frame
MDOT 1	Maryland DOT	Amtrak	Commuter		Budd	44	1955	Unpowered	Single-Level Coach	127 (79)	54500 (120000)	Coaches Only	GSI	Traditional	31e	
LRR 1	NYMTA	LRR	Commuter		Pullman Standard	189	1955-63	Unpowered	Single-Level Coach		54500 (120000)	Coaches Only	GSI	Traditional	31e	
SANF 1	PCJFB	Amtrak	Commuter		Sumikomo/Nippon Sharyo	73	1985-1987	Unpowered	Bi-level Coach		59000 (130000)	Includes Cab Cars	GSI	Traditional	31e	Recycled Trad., Anti Roll Bar
VRE 1	VRE	Amtrak	Commuter		Budd	21	1955	Unpowered	Single-Level Coach		48000 (106000)	Ex Boston RDC's	GSI	Traditional	31e	
						Total										
<b>Type 31e-P2: Traditional GSI with Equalizer Beam Primary, Bearings Outside Wheels, and Swinghanger Secondary, Powered</b>																
MNCR 1	NYMTA	MNCR	Commuter		Pullman Standard	61	1962	Powered	Single-Level MU Coach		54000 (120000)	11.5 kv AC Overhead + DC 3rd Rail	GSI	Traditional	31e-P2	
						Total										
<b>Type 32i: Equalizer Beam Primary, Bearings Inside Wheels, and Yaw Pivot Below Secondary Suspension, Unpowered</b>																
MBTA 1	MBTA	Amtrak	Commuter		Pullman Standard	57	1979	Unpowered	Single-Level Coach		43000 (95000)	Includes Cab Cars	GSI	General 70	32i	Inside Frame
MBTA 2	MBTA	Amtrak	Commuter		MBB	67	1987-88	Unpowered	Single-Level Coach		43000 (95000)	Includes Cab Cars	GSI	General 70	32i	Inside Frame
MBTA 3	MBTA	Amtrak	Commuter		Bombardier	147	1987-90	Unpowered	Single-Level Coach		43000 (95000)	Includes Cab Cars	GSI	General 70	32i	Inside Frame
MNCR 5	NYMTA	MNCR	Commuter		Bombardier	60	1986	Unpowered	Single-Level Coach		40000 (88000)	Includes Cab Cars	GSI	General 70	32i	Inside Frame
MNCR 7	NYMTA	MNCR	Commuter		Bombardier	18	1991	Unpowered	Single-Level Coach		40000 (88000)	Includes Cab Cars	GSI	General 70	32i	Inside Frame
NJT 1	NJT		Commuter	Comet IB	St Louis Car	30	1968	Unpowered	Single-Level Coach		41000 (90000)	Includes Cab Cars	GSI	General 70	32i	Inside Frame
NJT 2	NJT		Commuter	Comet I	Pullman Standard	147	1971	Unpowered	Single-Level Coach		41000 (90000)	Includes Cab Cars	GSI	General 70	32i	Inside Frame
NJT 5	NJT		Commuter	Comet II and IIA Coach	Bombardier	132	1962-83	Unpowered	Single-Level Coach		41000 (90000)	Includes Cab Cars	GSI	General 70	32i	Inside Frame
NJT 6	NJT		Commuter	Comet IIB Coach	Bombardier	52	1987-88	Unpowered	Single-Level Coach		41000 (90000)	Includes Cab Cars	GSI	General 70	32i	Inside Frame
NJT 7	NJT		Commuter	Comet III Coach	Bombardier	5	1990-91	Unpowered	Single-Level Coach		41000 (90000)	Includes Cab Cars	GSI	General 70	32i	Inside Frame
SEPTA 4	SEPTA		Commuter		Bombardier	35	1987	Unpowered	Single-Level Coach		42000 (92000)	Includes Cab Cars	GSI	General 70	32i	Inside Frame
						Total										
<b>Type 32i-P2: Equalizer Beam Primary, Bearings Inside Wheels, and Yaw Pivot Below Secondary Suspension, Powered</b>																
LRR 4	NYMTA	LRR	Commuter	M3 MU Coach	Budd	174	1985	Powered	Single-Level MU Coach		50000 (110000)	3rd Rail 750V DC Electrification	GSI	General 70	32i-P2	Powered Inside Frame
MNCR 3	NYMTA	MNCR	Commuter	M2 MU Coach	General Electric	242	1973	Powered	Single-Level MU Coach		50000 (110000)	11.5 kv AC Overhead + DC 3rd Rail	GSI	General 70	32i-P2	Powered Inside Frame
MNCR 4	NYMTA	MNCR	Commuter	M3A MU Coach	Budd	142	1984	Powered	Single-Level MU Coach		50000 (110000)	750v 3rd Rail DC Electric	GSI	General 70	32i-P2	Powered Inside Frame
MNCR 8	NYMTA	MNCR	Commuter	M6 MU Coach	Morrison Knudsen	48	1993-94	Powered	Single-Level MU Coach		50000 (110000)	11.5 kv AC Overhead + DC 3rd Rail	GSI	General 70	32i-P2	Powered Inside Frame
NJT 3	NJT		Commuter	Arrow II MU Coach	General Electric	70	1974-75	Powered	Single-Level MU Coach		50000 (110000)	11.5 kv Overhead Electric	GSI	General 70	32i-P2	Powered Inside Frame
NJT 4	NJT		Commuter	Arrow III MU Coach	General Electric	230	1977-78	Powered	Single-Level MU Coach		50000 (110000)	11.5 kv Overhead Electric	GSI	General 70	32i-P2	Powered Inside Frame
SEPTA 1	SEPTA		Commuter	Silverliner II MU Coach	Budd	53	1963-64	Powered	Single-Level MU Coach		50000 (110000)	11.5 kv Overhead Electric	GSI	General 70	32i-P2	Powered Inside Frame
SEPTA 2	SEPTA		Commuter	Silverliner III MU Coach	St Louis Car	20	1967	Powered	Single-Level MU Coach		50000 (110000)	11.5 kv Overhead Electric	GSI	General 70	32i-P2	Powered Inside Frame
SEPTA 3	SEPTA		Commuter	Silverliner IV MU Coach	General Electric	231	1973-77	Powered	Single-Level MU Coach		50000 (110000)	11.5 kv Overhead Electric	GSI	General 70	32i-P2	Powered Inside Frame
						Total										
						Total										



Table A2-2 Passenger Car Population Data by Truck Classification (continued)  
[Effective Date Approximately 1/1/94]

Car Series	Owner	Contract Operator (If Different)	Type of Operation	Series Name (Where Used)	Manufacturer	Number In Service	Dates Put into Service	Powered or Unpowered	Body Type	Car Description		Comments	Truck Description			
										Typical Max Speed km/h (mph)	Approximate Total Weight (Empty) kg (lb)		Manufacturer	Model	Classification	Comments
<b>Type 32e: Equalizer Beam Primary, Bearings Outside Wheels, and Yaw Pivot Below Secondary Suspension, Unpowered</b>																
AMTK 9	Amtrak		Intercity	Horizon	Bombardier	103	1989-90	Unpowered	Single-Level Coach	201 (125)	53000 (118000)	Coaches and Food Service Cars	GSI	General 70	32e	Outside Frame
AMTK 10	Amtrak		Intercity	Superliner II Bi-Level	Bombardier	128	1993-94	Unpowered	Full Bi-Level	177 (110)	70000 (155000)	Coaches, Dining and Sleepers	GSI	General 70	32e	Outside Frame
AMTK 11	Amtrak		Intercity	Viewliner	Morrison Knudsen	50	1993-94	Unpowered	Single-Level Coach	177 (110)		Coaches, Dining and Sleepers	GSI	General 70	32e	Outside Frame
COOT 1	California DOT		Intercity	California car	Morrison Knudsen	40	1994	Unpowered	Full Bi-Level	201 (125)	63500 (140000)	Includes Cab Cars	GSI	General 70	32e	Outside Frame
METRA 3	Chicago	METRA, BN, CNW	Commuter		Budd	66	1973-74	Unpowered	Gallery Bi-Level Coach		59000 (130000)	Includes Cab Cars	GSI	General 70	32e	Outside Frame
METRA 4	Chicago	METRA, BN, CNW	Commuter		Budd	104	1978-79	Unpowered	Gallery Bi-Level Coach		59000 (130000)	Includes Cab Cars	GSI	General 70	32e	Outside Frame
METRA 5	Chicago	METRA, BN, CNW	Commuter		Budd	50	1980	Unpowered	Gallery Bi-Level Coach		59000 (130000)	Includes Cab Cars	GSI	General 70	32e	Outside Frame
SANF 2	PCJFB	Amtrak	Commuter	California Coach	Morrison Knudsen	23	1993	Unpowered	Bi-level Coach		63500 (140000)	Includes Cab Cars	GSI	General 70	32e	Outside Frame
						Total	564									
<b>Type 32e-P2: Equalizer Beam Primary, Bearings Outside Wheels, and Yaw Pivot Below Secondary Suspension, Powered</b>																
METRA 2	Chicago	METRA, BN, CNW	Commuter		St Louis Car	129	1971-72	Powered	Gallery Bi-Level MU Coach		63500 (140000)	Overhead Catenary	GSI	General 70	32e-P2	Outside Frame, Powered
METRA 6	Chicago	METRA, BN, CNW	Commuter		Bombardier	36	1978-79	Powered	Gallery Bi-Level MU Coach		63500 (140000)	Overhead Catenary	GSI	General 70	32e-P2	Outside Frame, Powered
						Total	165									
<b>Type 41e: Journal Spring Primary, Bearings Outside Wheels, and Swing Hanger Secondary, Unpowered</b>																
AMTK 5	Amtrak		Intercity	Superliner Bi-Level	Pullman Standard	282	1979-81	Unpowered	Full Bi-Level	177 (110)	70000 (155000)	Coaches, Dining and Sleepers	Waggon Union	MD 76	41e	Wt 8250 kg (18187lb)
						Total	282									
<b>Type 42i: Journal Spring Primary, Bearings Inside Wheels, and Yaw Pivot Below Secondary Suspension, Unpowered</b>																
METRA 7	Chicago	METRA, BN, CNW	Commuter		Morrison Knudsen	173	1993-94	Unpowered	Gallery Bi-Level Coach		59000 (130000)	Includes Cab Cars	Acheson		42i	Dofasco Design
SCRRA 1	SCRRA	Amtrak	Commuter	Series V	UTDC Canada	63	1992	Unpowered	Lozenge Style Bi-Level		51000 (113000)	Includes Cab Cars	Dofasco		42i	
SCRRA 2	SCRRA	Amtrak	Commuter	Series V	Bombardier	43	1994	Unpowered	Lozenge Style Bi-Level		51000 (113000)	Includes Cab Cars	Dofasco		42i	
TRI 1	TCORA		Commuter	Series III	UTDC Canada	18	1992	Unpowered	Lozenge Style Bi-Level		51000 (113000)	Includes Cab Cars	Dofasco		42i	
TRI 2	TCORA		Commuter	Series V	UTDC Canada	3	1994	Unpowered	Lozenge Style Bi-Level		51000 (113000)	Includes Cab Cars	Dofasco		42i	
						Total	300									
<b>Type 42i-P2: Journal Spring Primary, Bearings Inside Wheels, and Yaw Pivot Below Secondary Suspension, Powered</b>																
MNCR 6	NYMTA	MNCR	Commuter	M4 MU Coach	Tokyu Car	54	1988	Powered	Single-Level MU Coach		50000 (110000)	11.5 kv AC Overhead + DC 3rd Rail	Tokyu Car		42i-P2	Fabricated, Inside Frame
						Total	54									
<b>Type 42e: Journal Spring Primary, Bearings Outside Wheels, and Yaw Pivot Below Secondary Suspension, Unpowered</b>																
MDOT 2	Maryland DOT	Amtrak	Commuter		Nippon Sharyo	64	1985-91	Unpowered	Single-Level Coach	177 (110)	50000 (111000)	Includes Cab Cars	Nippon Sharyo	NT 319	42e	Wt 6970 kg (15366 lb)
MDOT 3	Maryland DOT	Amtrak	Commuter		Sumitomo	11	1992-93	Unpowered	Single-Level Coach	177 (110)	50000 (111000)	Includes Cab Cars	Nippon Sharyo	NT 319	42e	Wt 6970 kg (15366 lb)
MBTA 4	MBTA	Amtrak	Commuter		Kawasaki	75	1993-94	Unpowered	Single-Level Coach		56000 (123500)	Includes Cab Cars	Kawasaki		42e	Outside Frame
VRE 2	VRE	Amtrak	Commuter		Morrison Knudsen	38	1992	Unpowered	Single-Level Coach		48000 (106000)	Includes Cab Cars	Tokyu Car	INT319	42e	Fabricated, Outside Frame
						Total	188									
<b>Type 42e-P2: Journal Spring Primary, Bearings Outside Wheels, and Yaw Pivot Below Secondary Suspension, Powered</b>																
NICTD 1	NICTD		Commuter		Sumitomo	41	1982-83	Powered	Single-Level MU Coach		48500 (107000)	Overhead Catenary	Nippon Sharyo	ND 312	42e-P2	
NICTD 2	NICTD		Commuter		Sumitomo	17	1992	Powered	Single-Level MU Coach		48500 (107000)	Overhead Catenary	Nippon Sharyo	ND 312	42e-P2	
						Total	58									
<b>Type 43e: Journal Spring Primary, Bearings Outside Wheels, and Bolsterless Secondary, Unpowered</b>																
AMTK 8	Amtrak		Intercity	Turbo Coach/Coach	Rohr/ANF	27	1975-77	Unpowered	Single-Level Coach	177 (110)		Coaches and Food Service Cars	ANF		43e	
LIRR 5	NYMTA	LIRR	Commuter	C1 MU Coach	Tokyu Car	10	1990	Powered	Bi-Level MU Coach		56000 (124000)	3rd Rail 750V DC Electrification	Comeng (Design)		43e	Fabricated, Bolsterless
						Total	37									
<b>Type 43e-P2: Journal Spring Primary, Frame Outside Bearings, and Bolsterless Secondary, Powered</b>																
AMTK 7	Amtrak		Intercity	Turbo Power Car	Rohr/ANF	18	1975-77	Powered	Single-Level Coach	177 (110)		Gas Turbine and Electric 3rd Rail	ANF		43e-P2	
						Total	18									
						Grand Total	6392									





## REFERENCES

1. J. M. Herring Jr, H. A. List, and M. J. Pavlick: "Engineering Data on North American Rapid Transit and Light Rail Vehicle Trucks," U.S. Department of Transportation, Transportation Systems Center, Cambridge Massachusetts, June 1984.
2. Stephen M. Shapiro: "Engineering Data on Selected High Speed Passenger Trucks," Federal Railroad Administration Report No. FRA/ORD-78/29, July 1978.
3. P. G. Przybylinski and G. B. Anderson: "Engineering Data Characterizing the Fleet of U.S. Railway Rolling Stock," Federal Railroad Administration Report No. FRA/ORD-81/75, November 1981.
4. J. A. Bachman et. al. "Improved Passenger Equipment Evaluation Program (IPEEP), Train System Review Reports," Federal Railroad Administration Report No. FRA/ORD 80/14.
5. Alan J. Bing: "HSR Safety Research Needs," Federal Railroad Administration Report No. FRA/ORD- 90/04.
6. Chris T. Boon, William F. Hayes, J. Kevin Kessler, and Brian T. Whitten: "High-Speed Tilt Train Technology: a State of the Art Survey," Federal Railroad Administration Report No. FRA/ORD/-92-03.
7. D. Wormley, K. Hedrick, D. Horak, and C. Bell: "Rail Passenger Vehicle Truck Design Methodology," Federal Railroad Administration Report No. FRA/ORD - 81/1, January 1981.
8. D. E. Newland and R. J. Cassidy: "Suspension and Structure: Some Fundamental Design Considerations for Railway Vehicles," Railway Engineering Journal, Institution of Mechanical Engineers (UK), March 1974.
9. Herbert Weinstöck: "Wheel Climb Criteria for Evaluation of Rail Vehicle Safety," American Society of Mechanical Engineers, paper 84-WA/RT-1, Winter Annual Meeting, 1984.
10. Raymond P. Owings and Patrick L. Boyd: "Railroad Passenger Ride Safety," Federal Railroad Administration Report, April 1989.
11. International Standard ISO 2631 "Evaluation of Human Exposure to Whole Body Vibration," International Standards Organization 1985 and 1989.
12. P. L. Boyd, R. E. Scofield, and J. P. Zaiko: "High Cant Deficiency Testing of the LRC Train, AEM7 Locomotive and the Amcoach," Federal Railroad Administration Report, January 1982.
13. "1994 Transit Passenger Vehicle Inventory," American Public Transit Association, April 1994.
14. Kenneth B. Ullman and Alan J. Bing, "High Speed Passenger Trains in Freight Railroad Corridors: Operations and Safety Considerations," Federal Railroad Administration Report No. DOT/FRA/ORD---/94.



1  
12



THE UNIVERSITY OF THE STATE OF NEW YORK  
LIBRARY OF THE STATE ARCHIVES  
ALBANY

