



U. S. Department
of Transportation
**Federal Railroad
Administration**

Safety of High Speed Guided Ground Transportation Systems

Office of Research
and Development
Washington, D.C. 20590

Magnetic and Electric Field Testing of the French Train A Grande Vitesse (TGV) Rail Systems

Volume I: Analysis

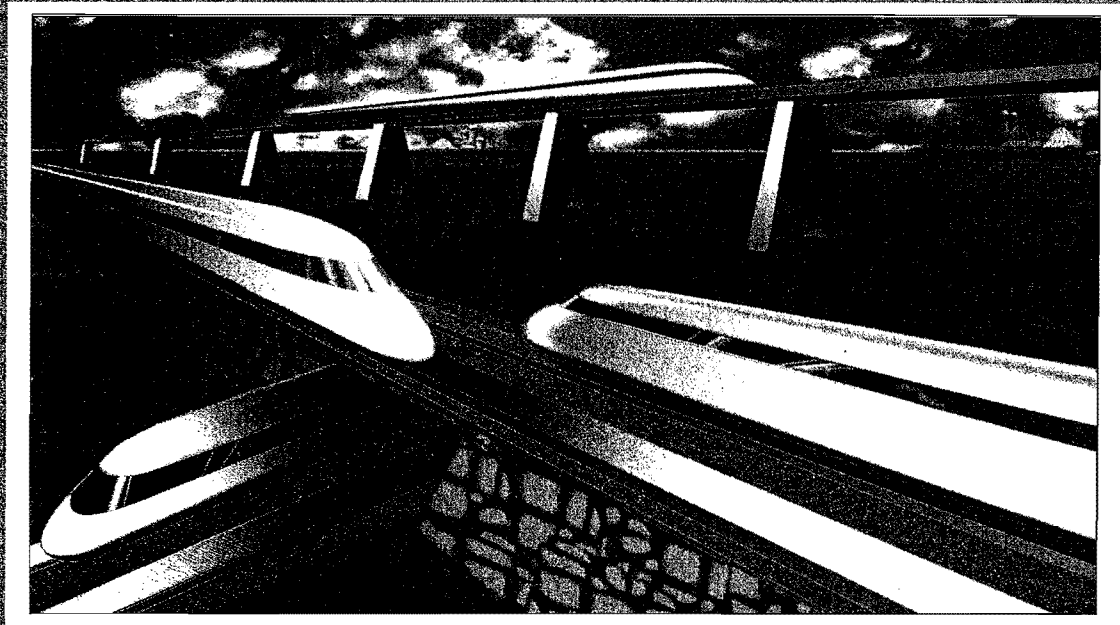

DOT/FRA/ORD-93/03.1
DOT-VNTSC-FRA-93-7.1

Final Report
May 1993

This document is available to the
public through the National Technical
Information Service, Springfield, VA 22161

REPORT DOCUMENTATION PAGE

Form Approved
OMB No. 0704-0188

Public reporting burden for this collection of information is estimated to average 1 hour per response, including the time for reviewing instructions, searching existing data sources, gathering and maintaining the data needed, and completing and reviewing the collection of information. Send comments regarding this burden estimate or any other aspect of this collection of information, including suggestions for reducing this burden, to Washington Headquarters Services, Directorate for Information Operations and Reports, 1215 Jefferson Davis Highway, Suite 1204, Arlington, VA 22202-4302, and to the Office of Management and Budget, Paperwork Reduction Project (0704-0188), Washington, DC 20503.

1. AGENCY USE ONLY (Leave blank)

2. REPORT DATE
May 1993

3. REPORT TYPE AND DATES COVERED
Final Report
September 1992 - March 1993

4. TITLE AND SUBTITLE Safety of High Speed Guided Ground Transportation Systems: Magnetic and Electric Field Testing of the French Train A Grande Vitesse (TGV) Volume I - Analysis

5. FUNDING NUMBERS
R3010/RR393

6. AUTHOR(S) Fred M. Dietrich, Petros N. Papas, William L. Jacobs, William E. Ferro *

7. PERFORMING ORGANIZATION NAME(S) AND ADDRESS(ES)
Electric Research and Management, Inc.
P.O. Box 165
State College, PA 16804

8. PERFORMING ORGANIZATION REPORT NUMBER
DOT-VNTSC-FRA-93-7.1

9. SPONSORING/MONITORING AGENCY NAME(S) AND ADDRESS(ES)
U.S. Department of Transportation
Federal Railroad Administration
Office of Research and Development
Washington, D.C. 20590

10. SPONSORING/MONITORING AGENCY REPORT NUMBER
DOT/FRA/ORD-93/03.1

11. SUPPLEMENTARY NOTES
* Under contract to: U.S. Department of Transportation
Research and Special Programs Administration
John A. Volpe National Transportation Systems Center
Kendall Square, Cambridge, MA 02142

12a. DISTRIBUTION/AVAILABILITY STATEMENT
This document is available to the public through the National Technical Information Service, Springfield, VA 22161

12b. DISTRIBUTION CODE

13. ABSTRACT (Maximum 200 words)

The safety of magnetically levitated (maglev) and high speed rail (HSR) trains proposed for application in the United States is the responsibility of the Federal Railroad Administration (FRA). A franchise has been awarded to the Texas High Speed Rail Corporation to operate a 200 mph French Train a Grande Vitesse (TGV) in the Texas Triangle (Dallas-Fort Worth, Houston, San Antonio), with construction to begin in 1995.

This report provides the Analysis (Vol. I) of results, and detailed data and statistical summaries (Vol. II, Appendices) of representative electric and magnetic field (EMF) profiles on TGV-A trains between Paris and Tours for two electro-technologies (1.5 KV DC near Paris, and 2x25 KV at 50 Hz AC). EMF data represent a range of train operating conditions and locations (in vehicles, stations and wayside), as well as in traffic control and electrical facilities. A portable magnetic field monitoring system (augmented to include an electric fields probe) was used to sample, record and store 3 axis static and AC magnetic fields waveforms simultaneously, at multiple locations. A real time Digital Audio Tape (DAT) recorder able to capture EMF transients, and two personal power-frequency magnetic field monitors were used to collect complementary data.

The statistical and Fourier analysis of results in Volume I-Analysis enable a comparative characterization of EMF intensities, and spatial and temporal variability, by frequency band, and by distance from the source. EMF Extra Low Frequency (ELF) levels for the TGV system are comparable to those produced by common home, work, and power lines. EMF field levels for the TGV rail system components are within the ranges of other common environmental EMF sources, but have specific frequency signatures. Volume II-Appendices catalogs and documents detailed data files by electro-technology, source and location.

14. SUBJECT TERMS Electric and Magnetic Fields (EMF); Static (dc) Magnetic field; Alternating (ac) Field; Extreme Low Frequency (ELF); Train a Grande Vitesse (TGV); Electrified Rail; Electric Locomotive; Traffic Control Center; Railroad Stations; Power Substations; Catenary; Autotransformer; Power Frequency (PF); Harmonics; Transients; Fourier Analysis; EMDEX Personal Magnetic Field Exposure Monitor; Digital Audio Tape (DAT) Recorder; MultiWave Magnetic Field Recording System.

15. NUMBER OF PAGES
220

16. PRICE CODE

17. SECURITY CLASSIFICATION OF REPORT
Unclassified

18. SECURITY CLASSIFICATION OF THIS PAGE
Unclassified

19. SECURITY CLASSIFICATION OF ABSTRACT
Unclassified

20. LIMITATION OF ABSTRACT

SYSTÈME INTERNATIONAL (SI) UNIT DEFINITIONS AND
CONVERSIONS USED IN THIS REPORT

DISTANCE (ENGLISH-TO-SI CONVERSION):

1 inch (in)	= 2.54 centimeters (cm)	= 0.025 meters (m)
1 foot (ft)	= 30.5 centimeters (cm)	= 0.305 meters (m)
1 yard (yd)	= 91.4 centimeters (cm)	= 0.914 meters (m)
1 mile (mi)	= 1.61 kilometers (km)	= 1,610 meters (m)

ELECTRICAL QUANTITIES:

Electric Fields

1 Volt/meter (V/m)	= 0.01 Volts/centimeter (V/cm)
1 kiloVolt/meter (kV/m)	= 1000 Volts/meter (V/m)
1 kiloVolt/meter (kV/m)	= 10 Volts/centimeter (V/cm)

Magnetic Flux Densities (English-to-SI Conversion)

10,000 Gauss (G)	= 1 Tesla (T)
10 milliGauss (mG)	= 1 microTesla (μ T)
1 milliGauss (mG)	= .1 microTesla (μ T)
0.01 milliGauss (mG)	= 1 nanoTesla (nT)

Electromagnetic Frequency Bands

1 cycle per second	= 1 Hertz (Hz)
1,000 cycles per second	= 1 kiloHertz (kHz)
Ultra Low Frequency (ULF) Band	= 0 Hz to 3 Hz
Extreme Low Frequency (ELF) Band	= 3 Hz to 3 kHz
Very Low Frequency (VLF) Band	= 3 kHz to 30 kHz
Low Frequency (LF) Band	= 30 kHz to 300 kHz

PREFACE

The Federal Railroad Administration (FRA) has undertaken a series of studies to assess the safety and facilitate the introduction of advanced high speed guided ground transportation (HSGGT) technology to the US. These studies include both magnetic levitation (maglev) and steel wheel on rail alternatives. HSGGT technology options, such as the French Train a Grande Vitesse (TGV), the Swedish Tilt Train (X2000), or the German Intercity Express (ICE), can be expected to undergo public scrutiny and environmental assessment in order to convincingly establish their safety. A franchise has been awarded to the Texas High Speed Rail Corporation to operate a 200 mph French TGV in the Texas Triangle (Dallas-Fort Worth, Houston, San Antonio), with construction to begin in 1995.

Timely development of technical information required for rulemaking initiatives is needed to ensure the public safety. An emerging concern that relates to the environment, workers and public health and safety is that potentially adverse health effects of extra-low frequency (ELF) electric and magnetic fields (EMF) commonly associated with power transmission and distribution lines. Magnetic fields are of greater concern, because they are pervasive, penetrate biological tissues without attenuation, and are more difficult to shield than electric fields.

To enable informed assessments and comparisons to be made amongst emerging and existing technologies, a thorough EMF characterization (frequency, intensity, spatial and temporal variability, source analysis) of all representative existing and advanced electrical transportation systems is needed.

This report is one of a comprehensive series of studies and reports addressing the ELF EMF safety issues for candidate HSGGT technologies and systems. Electric Research and Management, Inc. (ERM) was engaged to measure, characterize and analyze the EMF for representative existing and advanced rail and transit systems.

An EMF survey of the TGV-Atlantique (TGV-A) system, a close analog of the Texas proposal, was performed. This report presents data on static and alternating (AC) magnetic fields and AC electric fields obtained between Paris and Tours in September, 1992. Volume I, Analysis presents a summary of representative EMF data on rail system components and facilities, over a full range of operating conditions, as well as a comparison with EMF produced by home appliances and common electric power distribution and transmission lines. Volume II, Appendices contains detailed EMF data files by location, time, and frequency range, as well as statistics.

This report was prepared by a team of ERM personnel designated as authors for each volume, including: The ERM project was led by Fred M. Dietrich, Program Manager and William E. Feero, President.

The technical monitor for this task and for the series of reports characterizing ELF EMF for rail technologies was Dr. Aviva Brecher of the John A. Volpe National Transportation Systems Center

(VNTSC), who manages the FRA's EMF Research Program. Guidance and program support was provided by Robert Dorer, the HSGGT Safety Program Manager at VNTSC. Arne Bang, Senior Manager of Special Programs and the FRA sponsor for this work is thanked for overall direction and oversight.

The French National Rail Company (SNCF) provided a special TGV test trainset, access to facilities and excellent technical and logistical support. Special thanks are due to M. Jaques Balause and Jean- Michel Gayon of the SNCF International Affairs, Mme. Nicole Dubalen and Alain Jeunesse from the SNCF Center for Signal and Telecommunications, Christian Courtois, SNCF power system expert and Patrick Meyer, SNCF interpreter. Assistance from technical representatives from GEC Alsthom (especially G. Beaudienville) and the participation of other SNCF and French Ministry of Transportation representatives in our technical briefings are gratefully acknowledged.

VOLUME I

TABLE OF CONTENTS

<u>Section</u>	<u>Page</u>
1. EXECUTIVE SUMMARY	1-1
1.1 Background	1-1
1.2 Measurement Approach	1-3
1.3 Summary of TGV-A Field Levels	1-3
1.3.1 Coaches	1-4
1.3.2 Locomotive (Power Car) Cabs	1-4
1.3.3 Railroad Waysides	1-5
1.3.4 Passenger Station Platforms	1-5
1.3.5 Electric Power Supply Stations	1-5
1.3.6 Control Facilities	1-6
1.4 Comparison of TGV-A Fields to Other Electro- Technologies	1-6
1.4.1 Static Fields	1-6
1.4.2 Frequency Spectrum	1-6
1.4.3 Time Characteristics	1-7
1.4.4 Amplitude Characteristics	1-7
1.4.4.1 Coaches	1-7
1.4.4.2 Locomotive Cabs	1-7
1.4.4.3 Along the Wayside	1-7
1.4.4.4 Passenger Stations	1-11
1.4.4.5 Substations and Autotransformers	1-11
1.4.4.6 Control Center	1-11
1.5 Conclusions	1-16
2. OVERVIEW	2-1
2.1 Report Organization	2-1
2.2 Background	2-2
2.2.1 Geomagnetic Field Characteristics	2-2
2.2.2 Technological Magnetic Field Perturbations	2-3
2.2.3 Electric and Magnetic Fields and Biological Effects	2-3
2.3 The French TGV-A Train and Rail System	2-5
2.4 Approach to Organizing Electromagnetic Data ...	2-6
2.5 Instrumentation	2-7
2.5.1 Portable Waveform Capture System	2-9
2.5.2 Digital Audio Tape Recorder	2-10
2.5.3 EMDEX-II Recorders	2-10

VOLUME I

TABLE OF CONTENTS (CONT'D)

<u>Section</u>		<u>Page</u>
	2.6 Repetitive Waveform Data	2-10
	2.7 DAT Waveform Data	2-11
	2.8 RMS Recorder Data	2-12
3.	ONBOARD COACH MEASUREMENTS	3-1
	3.1 Measurement Locations	3-3
	3.2 Repetitive Waveform Datasets	3-4
	3.3 Magnetic Field Source Identification.....	3-6
	3.4 DAT Waveform Data	3-18
	3.5 RMS Recorder Data	3-19
	3.6 Summary of Magnetic Field Levels	3-20
	3.7 Electric Field Sources and Levels	3-26
4.	ENGINEER'S COMPARTMENT MEASUREMENTS	4-1
	4.1 Measurement Locations	4-1
	4.2 Repetitive Waveform Datasets.....	4-3
	4.3 Field Source Identification	4-3
	4.4 DAT Waveform Data	4-10
	4.5 RMS Recorder Data	4-12
	4.6 Summary of Magnetic Field Levels	4-13
	4.6.1 Train Stationary	4-13
	4.6.2 Trains Operating on DC	4-13
	4.6.3 Trains Operating on AC	4-13
	4.6.4 Effects of Passenger Load	4-18
	4.7 Electric Field Sources and Levels	4-20
5.	MEASUREMENTS ALONG THE WAYSIDE	5-1
	5.1 Measurement Locations	5-1
	5.2 Repetitive Waveform Datasets	5-1
	5.3 Field Source Identification	5-5
	5.3.1 At Overpass	5-5
	5.3.2 At Underpass	5-7
	5.3.3 At Grade Open Space	5-10
	5.4 DAT Waveform Data	5-12
	5.5 RMS Recording Data	5-14
	5.6 Summary of Magnetic Field Levels	5-17
	5.7 Attenuation of Magnetic Fields	5-22
	5.8 Summary of Electric Field Levels	5-22

VOLUME I

TABLE OF CONTENTS (CONT'D)

<u>Section</u>	<u>Page</u>
6. PASSENGER STATION MEASUREMENTS	6-1
6.1 Measurement Locations	6-1
6.2 Repetitive Waveform Datasets	6-1
6.3 Field Source Identification	6-1
6.4 DAT Waveform Data	6-8
6.5 RMS Recorder Data	6-9
6.6 Summary of Magnetic Field Levels	6-12
7. POWER SUPPLY SYSTEM MEASUREMENTS	7-1
7.1 Measurement Locations	7-1
7.2 Repetitive Waveform Datasets	7-4
7.3 Field Source Identification	7-5
7.4 DAT Waveform Data	7-7
7.5 RMS Recorder Data	7-10
7.6 Summary of Magnetic Field Levels	7-11
7.7 Summary of Electric Field Levels	7-15
8. MEASUREMENTS AT TRAFFIC CONTROL FACILITIES	8-1
8.1 Measurement Locations	8-1
8.2 Repetitive Waveform Datasets	8-1
8.3 Field Source Identification	8-4
8.4 DAT Waveform Data	8-6
8.5 Summary of Magnetic Field Levels	8-8
9. CONCLUSIONS	9-1
9.1 Summary of TGV-A Field Levels	9-1
9.1.1 Coaches	9-1
9.1.2 Locomotive (Power Car) Cabs	9-2
9.1.3 Railroad Waysides	9-2
9.1.4 Passenger Station Platforms	9-3
9.1.5 Electric Power Supply Stations	9-3
9.1.6 Traffic Control Facilities	9-4
9.2 Environmental Magnetic Field Levels	9-4
9.3 Comparison of TGV-A Fields to Other Electro- Technologies	9-8
9.3.1 Static Fields	9-8
9.3.2 Frequency Characteristics	9-10
9.3.3 Time Characteristics	9-10
9.3.4 Amplitude Characteristics	9-10
9.3.4.1 Coaches	9-10
9.3.4.2 Locomotive Cabs	9-12

VOLUME I

TABLE OF CONTENTS (CONT'D)

<u>Section</u>		<u>Page</u>
	9.3.4.3 Along the Wayside	9-12
	9.3.4.4 Passenger Stations	9-15
	9.3.4.5 Substations and Autotransformers	9-15
	9.3.4.6 Traffic Control Centers	9-21
9.4	Comparison of TGV-A Fields to Existing Standards	9-21
9.4.1	World Health Organization	9-21
9.4.2	International Radiation Protection Association	9-23
9.4.3	American Conference of Governmental Industrial Hygienists	9-24
9.4.4	State Power Line Limits	9-24
10.	REFERENCES	10-1

VOLUME I

LIST OF FIGURES

<u>Figure</u>		<u>Page</u>
1-1	ROUTE OF THE TGV ATLANTIQUE WITH LOCATIONS OF WAYSIDE, AUTOTRANSFORMER AND SUBSTATION MEASUREMENTS.....	1-2
1-2	THE RANGE OF TOTAL TIME VARYING MAGNETIC FIELD LEVELS IN THE TGV-A PASSENGER COACHES AT VARIOUS HEIGHTS ABOVE THE FLOOR COMPARED TO TYPICAL LEVELS OF POWER-FREQUENCY MAGNETIC FIELDS PRODUCED BY COMMON SOURCES AT VARIOUS DISTANCES FROM THE SOURCE	1-8
1-3	THE RANGE OF TOTAL TIME VARYING MAGNETIC FIELD LEVELS IN THE TGV-A LOCOMOTIVE CABS AT VARIOUS HEIGHTS ABOVE THE FLOOR COMPARED TO TYPICAL LEVELS OF POWER-FREQUENCY MAGNETIC FIELDS PRODUCED BY COMMON SOURCES AT VARIOUS DISTANCES FROM THE SOURCE	1-9
1-4	THE RANGE OF TOTAL TIME VARYING MAGNETIC FIELD ON AN OVERPASS, UNDERPASS AND OPEN SPACE ALONG THE WAYSIDE OF THE TGV-A ELECTRIFIED RAILROAD AT VARIOUS DISTANCES FROM THE NEAREST TRACK, COMPARED TO TYPICAL LEVELS OF POWER-FREQUENCY MAGNETIC FIELDS PRODUCED BY COMMON SOURCES	1-10
1-5	MAXIMUM TIME VARYING ELECTRIC FIELD AT THE WAYSIDE OF THE TGV-A ELECTRIFIED RAILROAD AS A FUNCTION OF DISTANCE FROM THE NEAREST TRACK COMPARED TO TYPICAL LEVELS OF POWER-FREQUENCY ELECTRIC FIELDS PRODUCED BY COMMON SOURCES	1-12
1-6	THE RANGE OF TOTAL TIME VARYING MAGNETIC FIELD LEVELS ON THE VENDOME STATION PLATFORM APPROXI- MATELY 1.5 m (5 ft) FROM CENTERLINE OF THE NEAREST TRACK COMPARED TO TYPICAL POWER-FREQUENCY MAGNETIC FIELD LEVELS FROM COMMON SOURCES	1-13
1-7	MEASURED TOTAL TIME VARYING ELECTRIC FIELD AT SUBSTATION LOW AND HIGH VOLTAGE SIDES AND AUTOTRANSFORMER STATION AS A FUNCTION OF DISTANCE FROM FENCE, COMPARED TO TYPICAL POWER-FREQUENCY ELECTRIC FIELD LEVELS FROM COMMON SOURCES	1-14
1-8	THE RANGE OF TOTAL TIME VARYING MAGNETIC FIELD LEVELS IN FRONT OF A DISPATCHER'S VIDEO DISPLAY TERMINAL COMPARED TO TYPICAL POWER-FREQUENCY MAGNETIC FIELD LEVELS FROM COMMON SOURCES	1-15

VOLUME I

LIST OF FIGURES (CONT'D)

<u>Figure</u>		<u>Page</u>
2-1	MEASUREMENTS BEING TAKEN ON A TGV-A STATION PLATFORM WITH THE WAVEFORM CAPTURE SYSTEM	2-6
2-2	MAGNETIC FIELD FLUX DENSITIES GROUPED BY FREQUENCY PARTITIONS WITHIN THE ELF BAND AND ULF BAND	2-8
3-1	TRAIN LAYOUT AND REPETITIVE WAVEFORM MEASUREMENT LOCATIONS FOR BOTH THE DOUBLE TEST TRAIN (FIRST DAY) AND THE SINGLE REVENUE TRAIN (SECOND DAY)	3-2
3-2	REPETITIVE WAVEFORM MEASUREMENT LOCATIONS IN CARS R1B-FIRST CLASS SALON, R2B-FIRST CLASS CLUB COACH AND R5B-SECOND CLASS COACH	3-5
3-3	MAGNETIC FIELD LEVEL, WITH AND WITHOUT THE STATIC COMPONENT, I.E., TRANSITION FROM DC TO AC TRACK SECTIONS AT APPROXIMATELY 500 SECONDS, 60 cm HEIGHT ABOVE THE FLOOR IN THE FIRST COACH AS A FUNCTION OF FREQUENCY AND TIME	3-9
3-4	VERTICAL PROFILE OF POWER FREQUENCY (50-60 Hz) AND POWER HARMONICS MAGNETIC FIELDS OVER TIME IN THE FIRST COACH	3-11
3-5	VERTICAL PROFILE OF POWER FREQUENCY (50-60 Hz) MAGNETIC FIELDS FOR ALL COACHES	3-12
3-6	VERTICAL PROFILE OF AVERAGE VALUE OF POWER FREQUENCY (50-60 Hz) MAGNETIC FIELDS FOR THE THREE COACHES ...	3-13
3-7	MAGNETIC FIELD LEVEL OF POWER FREQUENCY (50-60 Hz) COMPARISON AMONG THE COACHES	3-15
3-8	TRANSVERSE PROFILE OF POWER FREQUENCY (50-60 Hz) MAGNETIC FIELDS FOR ALL COACHES	3-17
3-9	ELECTRIC FIELD LEVEL AS A FUNCTION OF FREQUENCY AND TIME AT 170 cm ABOVE THE FLOOR IN COACH R1B OF THE TGV-A	3-27
4-1	FIELD MEASUREMENT LOCATIONS IN THE CAB OF THE TEST TRAIN AND CAB OF A NORMAL SCHEDULED TRAIN IN REVENUE SERVICE	4-2
4-2	MAGNETIC FIELD LEVEL BY TIME AND FREQUENCY AT A POINT NEAR THE ENGINEER IN THE CAB OF A TGV-A TRAIN AS IT DEPARTS ST. PIERRE-DES-CORPS ENROUTE TO PARIS. THE STATIC FIELD COMPONENT IS SUPPRESSED IN THE LOWER FRAME	4-5

VOLUME I

LIST OF FIGURES (CONT'D)

<u>Figure</u>		<u>Page</u>
4-3	MAGNETIC FIELD LEVELS VERSUS HEIGHT ABOVE THE FLOOR OVER TIME FOR STATIC FIELDS AND FIELDS IN THE LOW FREQUENCY (5-45 Hz) BAND, AT A POINT NEAR THE ENGINEER'S RIGHT SHOULDER	4-7
4-4	MAGNETIC FIELD LEVELS VERSUS HEIGHT ABOVE THE FLOOR OVER TIME FOR FIELDS IN THE POWER FREQUENCY (50-60 Hz) AND POWER HARMONIC (65-300 Hz) BANDS, AT A POINT NEAR THE ENGINEER'S RIGHT SHOULDER	4-8
4-5	MAGNETIC FIELD LEVEL 1.3 m (4.3 ft) ABOVE THE FLOOR VERSUS DISTANCE FORWARD OF THE CAB'S REAR BULKHEAD OVER TIME, FOR FIELDS IN THE POWER FREQUENCY (50-60 Hz) BAND ALONG THE CENTERLINE OF THE LOCOMOTIVE	4-9
4-6	MAGNETIC FIELD LEVEL BY TIME AND FREQUENCY AT A POINT NEAR THE ENGINEER IN THE CAB OF A TGV-A TRAIN SHOWING ONLY FIELD COMPONENTS IN THE 2000 TO 2560 Hz RANGE	4-11
4-7	EXAMPLE OF ELECTRIC FIELD MEASURED IN THE LOCOMOTIVE AT STANDING HEAD POSITION BY THE ENGINEER'S SEAT	4-21
5-1	REPETITIVE WAVEFORM MEASUREMENT LOCATION ON THE HIGHWAY OVERPASS NEAR 121 km MARKER	5-2
5-2	REPETITIVE WAVEFORM MEASUREMENT LOCATION AT THE HIGHWAY UNDERPASS NEAR 105 km MARKER	5-3
5-3	REPETITIVE WAVEFORM MEASUREMENT LOCATION AT AN OPEN SPACE ALONG THE WAYSIDE NEAR 104 km MARKER	5-4
5-4	MAGNETIC FIELD LEVEL, WITH AND WITHOUT THE STATIC COMPONENT, AT 110 cm HEIGHT ABOVE THE SIDEWALK ON THE OVERPASS AS A FUNCTION OF FREQUENCY AND TIME ...	5-6
5-5	ELECTRIFICATION SCHEMATIC FOR THE AC POWERED SECTION OF THE TGV ATLANTIQUE LINE SHOWING THE LOCATION OF THE SUBSTATIONS AND THE AUTOTRANSFORMERS	5-8
5-6	MAGNETIC FIELD LEVEL, WITH AND WITHOUT THE STATIC COMPONENT, AT 110 cm HEIGHT ABOVE THE PAVEMENT AT THE HIGHWAY UNDERPASS AS A FUNCTION OF FREQUENCY AND TIME	5-9

VOLUME I

LIST OF FIGURES (CONT'D)

<u>Figure</u>		<u>Page</u>
5-7	MAGNETIC FIELD LEVEL, WITH AND WITHOUT THE STATIC COMPONENT, AT 10 cm HEIGHT ABOVE THE GROUND, AT AN OPEN SPACE ALONG THE WAYSIDE NEAR 104 km MARKER, AS A FUNCTION OF FREQUENCY AND TIME	5-11
5-8	MAGNETIC FIELD LEVEL, WITH AND WITHOUT THE STATIC COMPONENT, OF THE REFERENCE PROBE AT 10 cm HEIGHT ABOVE THE GROUND AND 15 m (49 ft) AWAY FROM THE STAFF, AT AN OPEN SPACE ALONG THE WAYSIDE NEAR 104 km MARKER, AS A FUNCTION OF FREQUENCY AND TIME	5-13
5-9	MAGNETIC FIELD LEVEL AS RECORDED BY THE DAT AT A POINT 22.5 m (74 ft) FROM CENTERLINE OF THE NEAREST TRACK, AS A FUNCTION OF TIME, AT AN OPEN SPACE ALONG THE WAYSIDE NEAR THE 104 km MARKER	5-15
5-10	MAGNETIC FIELD LEVEL AS RECORDED USING AN RMS RECORDER, AT AN OPEN SPACE ALONG THE WAYSIDE NEAR 104 km MARKER, AS A FUNCTION OF TIME	5-16
5-11	PROFILE OF ELECTRIC FIELD LEVEL AT AN OPEN SPACE ALONG THE WAYSIDE, AS A FUNCTION OF PERPENDICULAR DISTANCE FROM THE TRACKS	5-24
6-1	REPETITIVE WAVEFORM MEASUREMENT LOCATIONS ON THE PASSENGER PLATFORM AT VENDOME	6-2
6-2	ELECTRIFICATION SCHEMATIC FOR THE AC POWERED SECTION OF THE TGV ATLANTIQUE LINE SHOWING THE LOCATION OF THE SUBSTATIONS AND AUTOTRANSFORMERS	6-3
6-3	MAGNETIC FIELD LEVEL, WITH AND WITHOUT THE STATIC COMPONENT, AT 110 cm HEIGHT ABOVE THE PASSENGER PLATFORM AT VENDOME WHILE A TRAIN FROM PARIS PASSED BY, AS A FUNCTION OF FREQUENCY AND TIME	6-5
6-4	MAGNETIC FIELD LEVEL, WITH AND WITHOUT THE STATIC COMPONENT, AT 110 cm HEIGHT ABOVE THE PASSENGER PLATFORM AT VENDOME WHILE ANOTHER TRAIN FROM PARIS PASSED BY, AS A FUNCTION OF FREQUENCY AND TIME	6-6
6-5	MAGNETIC FIELD LEVEL, WITH AND WITHOUT THE STATIC COMPONENT, AT 110 cm HEIGHT ABOVE THE PASSENGER PLATFORM AT VENDOME WHILE A TRAIN TO PARIS PASSED BY, AS A FUNCTION OF FREQUENCY AND TIME	6-7
6-6	MAGNETIC FIELD LEVEL RECORDED ON THE PASSENGER PLATFORM AT VENDOME USING AN RMS RECORDER, WHILE A TRAIN FROM PARIS PASSED BY, AS A FUNCTION OF TIME	6-10

VOLUME I

LIST OF FIGURES (CONT'D)

<u>Figure</u>		<u>Page</u>
6-7	MAGNETIC FIELD LEVEL RECORDED ON THE PASSENGER PLATFORM AT VENDOME USING AN RMS RECORDER, WHILE A TRAIN TO PARIS PASSES BY, AS A FUNCTION OF TIME	6-11
7-1	REPETITIVE WAVEFORM MEASUREMENT LOCATIONS AT THE GAULT ST. DENIS SUBSTATION, ALSO SHOWING THE ELECTRIC FIELD PROFILES	7-2
7-2	REPETITIVE WAVEFORM MEASUREMENT LOCATIONS AT THE CHAILLOT AUTOTRANSFORMER STATION, ALSO SHOWING THE ELECTRIC FIELD PROFILE	7-3
7-3	MAGNETIC FIELD LEVEL, WITH AND WITHOUT THE STATIC COMPONENT, AT 110 cm HEIGHT ABOVE GROUND NEAR THE FENCE AT GAULT ST. DENIS SUBSTATION, AS A FUNCTION OF FREQUENCY AND TIME	7-6
7-4	MAGNETIC FIELD LEVEL, WITH AND WITHOUT THE STATIC COMPONENT, AT 110 cm HEIGHT ABOVE GROUND INSIDE THE CONTROL HOUSE AT GAULT ST. DENIS SUBSTATION, AS A FUNCTION OF FREQUENCY AND TIME	7-8
7-5	MAGNETIC FIELD LEVEL, WITH AND WITHOUT THE STATIC COMPONENT, AT 110 cm HEIGHT ABOVE GROUND NEAR THE FENCE AT CHAILLOT AUTOTRANSFORMER STATION, AS A FUNCTION OF FREQUENCY AND TIME	7-9
7-6	PROFILE OF ELECTRIC FIELD LEVEL NEAR THE GAULT ST. DENIS SUBSTATION ON THE LOW VOLTAGE SIDE, AS A FUNCTION OF PERPENDICULAR DISTANCE FROM THE FENCE	7-17
7-7	PROFILE OF ELECTRIC FIELD LEVEL NEAR THE GAULT ST. DENIS SUBSTATION ON THE HIGH VOLTAGE SIDE, AS A FUNCTION OF PERPENDICULAR DISTANCE FROM THE FENCE	7-18
7-8	PROFILE OF ELECTRIC FIELD LEVEL NEAR THE CHAILLOT AUTOTRANSFORMER STATION, AS A FUNCTION OF PERPENDICULAR DISTANCE FROM THE FENCE	7-19
8-1	REPETITIVE WAVEFORM MEASUREMENT LOCATIONS INSIDE THE TGV-A CONTROL CENTER AT GARE MONTPARNASSE	8-2
8-2	REPETITIVE WAVEFORM MEASUREMENT LOCATIONS INSIDE THE RELAY ROOM AT VENDOME	8-3

VOLUME I

LIST OF FIGURES (CONT'D)

<u>Figure</u>		<u>Page</u>
8-3	MAGNETIC FIELD LEVEL, WITH AND WITHOUT THE STATIC COMPONENT, AT 10 cm HEIGHT ABOVE THE FLOOR AND IN FRONT OF THE CENTERMOST MONITOR SCREEN INSIDE THE TGV-A CONTROL CENTER AT GARE MONTPARNASSE, AS A FUNCTION OF FREQUENCY AND TIME	8-5
8-4	MAGNETIC FIELD LEVEL, WITH AND WITHOUT THE STATIC COMPONENT, AT 110 cm HEIGHT ABOVE THE FLOOR NEAR THE AC SUPPLY CABINET INSIDE THE RELAY ROOM AT VENDOME, AS A FUNCTION OF FREQUENCY AND TIME	8-7
9-1	ILLUSTRATION OF HOW THE MAGNETIC FIELD INTENSITY AT GROUND LEVEL CHANGES WITH HORIZONTAL DISTANCE FROM THREE COMMON SOURCES OF POWER-FREQUENCY MAGNETIC FIELDS. THE BANDS REPRESENT VARIATION ACROSS INDIVIDUAL SOURCES IN EACH GROUP. ADAPTED FROM NAIR, ET AL ⁴	9-6
9-2	MAGNETIC FIELD 30 cm FROM A SHOP VAC	9-7
9-3	ILLUSTRATION OF HOW ELECTRIC FIELD INTENSITY NEAR GROUND LEVEL WILL CHANGE WITH HORIZONTAL DISTANCE FROM THREE COMMON SOURCES OF POWER-FREQUENCY ELECTRIC FIELDS. THE BANDS REPRESENT VARIATION ACROSS INDIVIDUAL SOURCES IN EACH GROUP. ADAPTED FROM NAIR, ET AL ⁴	9-9
9-4	THE RANGE OF TOTAL TIME VARYING MAGNETIC FIELD LEVELS IN THE TGV-A PASSENGER COACHES AT VARIOUS HEIGHTS ABOVE THE FLOOR COMPARED TO TYPICAL LEVELS OF POWER-FREQUENCY MAGNETIC FIELDS PRODUCED BY COMMON SOURCES AT VARIOUS DISTANCES FROM THE SOURCE	9-11
9-5	THE RANGE OF TOTAL TIME VARYING MAGNETIC FIELD LEVELS IN THE TGV-A LOCOMOTIVE CABS AT VARIOUS HEIGHTS ABOVE THE FLOOR COMPARED TO TYPICAL LEVELS OF POWER-FREQUENCY MAGNETIC FIELDS PRODUCED BY COMMON SOURCES AT VARIOUS DISTANCES FROM THE SOURCE	9-13
9-6	THE RANGE OF TOTAL TIME VARYING MAGNETIC FIELD ON AN OVERPASS, UNDERPASS AND OPEN SPACE ALONG THE WAYSIDE OF THE TGV-A ELECTRIFIED RAILROAD AT VARIOUS DISTANCES FROM THE NEAREST TRACK, COMPARED TO TYPICAL LEVELS OF POWER-FREQUENCY MAGNETIC FIELDS PRODUCED BY COMMON SOURCES	9-14

VOLUME I

LIST OF FIGURES (CONT'D)

<u>Figure</u>		<u>Page</u>
9-7	MAXIMUM TIME VARYING ELECTRIC FIELD AT THE WAYSIDE OF THE TGV-A ELECTRIFIED RAILROAD AS A FUNCTION OF DISTANCE FROM THE NEAREST TRACK COMPARED TO TYPICAL LEVELS OF POWER-FREQUENCY ELECTRIC FIELDS PRODUCED BY COMMON SOURCES	9-16
9-8	THE RANGE OF TOTAL TIME VARYING MAGNETIC FIELD LEVELS ON THE VENDOME STATION PLATFORM APPROXIMATELY 1.5 m (5 ft) FROM CENTERLINE OF THE NEAREST TRACK COMPARED TO TYPICAL POWER-FREQUENCY MAGNETIC FIELD LEVELS FROM COMMON SOURCES	9-17
9-9	THE RANGE OF TOTAL TIME VARYING MAGNETIC FIELD LEVELS AT VARIOUS DISTANCES OUTSIDE THE FENCE OF THE GAULT ST. DENIS SUBSTATION COMPARED TO TYPICAL POWER-FREQUENCY MAGNETIC FIELD LEVELS FROM COMMON SOURCES	9-18
9-10	THE RANGE OF TOTAL TIME VARYING MAGNETIC FIELD LEVELS AT VARIOUS DISTANCES OUTSIDE THE FENCE OF THE CHAILLOT AUTOTRANSFORMER COMPARED TO TYPICAL POWER-FREQUENCY MAGNETIC FIELD LEVELS FROM COMMON SOURCES	9-19
9-11	MEASURED TOTAL TIME VARYING ELECTRIC FIELD AT SUBSTATION LOW AND HIGH VOLTAGE SIDES AND AUTOTRANSFORMER STATION AS A FUNCTION OF DISTANCE FROM FENCE, COMPARED TO TYPICAL POWER-FREQUENCY ELECTRIC FIELD LEVELS FROM COMMON SOURCES	9-20
9-12	THE RANGE OF TOTAL TIME VARYING MAGNETIC FIELD LEVELS IN FRONT OF A DISPATCHER'S VIDEO DISPLAY TERMINAL COMPARED TO TYPICAL POWER-FREQUENCY MAGNETIC FIELD LEVELS FROM COMMON SOURCES	9-22

VOLUME I

LIST OF TABLES

<u>Table</u>		<u>Page</u>
2-1	INDEX OF REPETITIVE WAVEFORM DATA FRENCH TGV-A SEPTEMBER 8-SEPTEMBER 9, 1992	2-13
2-2	INDEX OF CONTINUOUS WAVEFORM (DAT) DATA FRENCH TGV-A MEASUREMENTS SEPTEMBER 8-SEPTEMBER 9, 1992	2-20
3-1	REPETITIVE MAGNETIC FIELD WAVEFORM DATASETS MEASURED ONBOARD COACHES	3-4
3-2	AVERAGE MAGNETIC FIELD VALUES IN mG MEASURED ONBOARD COACHES AT DIFFERENT OPERATING CONDITIONS	3-7
3-3	MAXIMUM MAGNETIC FIELD VALUES IN mG MEASURED ONBOARD COACHES AT DIFFERENT OPERATING CONDITIONS	3-8
3-4	LOG OF PASSING TRAINS AS SEEN FROM ONBOARD THE COACHES FOR THE DIFFERENT DATASETS	3-10
3-5	LOG OF POWER SUPPLY EQUIPMENT PASSED WHILE ONBOARD THE COACHES FOR THE DIFFERENT DATASETS	3-10
3-6	MAXIMUM AND AVERAGE MAGNETIC FIELD VALUES OF THE POWER FREQUENCY RANGE ON A TRANSVERSE PROFILE INSIDE THE COACHES FOR THE THREE CARS AND THE COMBINATION .	3-18
3-7	SUMMARY OF MAGNETIC FIELD LEVELS RECORDED IN A PASSENGER SEAT OF A COACH RECORDED WITH THE DIGITAL AUDIO TAPE RECORDER (DAT)	3-19
3-8	STATISTICAL SUMMARY OF MAGNETIC FIELD LEVELS RECORDED IN ALL COACHES USING RMS RECORDERS	3-21
3-9	SUMMARY STATISTICS FOR ALL VERTICAL DATASETS FOR ALL COACHES MEASURED WHILE TRAVELLING ALL SECTIONS OF THE LINE (DATASETS TGV001, 002, 012, 020, 021 AND 024)	3-22
3-10	SUMMARY STATISTICS FOR ALL VERTICAL DATASETS FOR ALL COACHES MEASURED WHILE TRAVELLING THE DC SECTIONS OF THE LINE (DATASETS TGV001, 012, AND 024)	3-23
3-11	SUMMARY STATISTICS FOR ALL VERTICAL DATASETS FOR ALL COACHES MEASURED WHILE TRAVELLING THE AC SECTIONS OF THE LINE (DATASETS TGV001, 002, 012, 020, 021 AND 024)	3-24

VOLUME I

LIST OF TABLES (CONT'D)

<u>Table</u>		<u>Page</u>
3-12	SUMMARY STATISTICS FOR ALL TRANSVERSE DATASETS FOR ALL COACHES MEASURED WHILE TRAVELLING THE AC SECTIONS OF THE LINE (DATASETS TGV004, 013, AND 022)	3-25
4-1	REPETITIVE MAGNETIC FIELD WAVEFORM DATASETS MEASURED IN LOCOMOTIVE CABS	4-4
4-2	SUMMARY OF TIME VARYING MAGNETIC FIELD LEVELS RECORDED ON THE CONSOLE IN FRONT OF THE ASSISTANT ENGINEER'S SEAT IN THE CAB OF THE TGV-A WITH THE DIGITAL AUDIO TAPE RECORDER (DAT)	4-11
4-3	STATISTICAL SUMMARY OF MAGNETIC FIELDS MEASURED IN LOCOMOTIVE CABS USING RMS RECORDERS	4-12
4-4	STATISTICAL SUMMARY OF MAGNETIC FIELD LEVELS AT VARIOUS HEIGHTS ABOVE THE FLOOR AT THE RIGHT REAR CORNER OF THE ENGINEER'S SEAT WHILE THE TRAIN IS AT REST	4-14
4-5	STATISTICAL SUMMARY OF MAGNETIC FIELD LEVELS AT VARIOUS HEIGHTS ABOVE THE FLOOR AT THE RIGHT REAR CORNER OF THE ENGINEER'S SEAT IN THE TEST TRAIN WHILE OPERATING ON A 1500 V DC CATENARY	4-15
4-6	STATISTICAL SUMMARY OF THE MAGNETIC FIELD LEVELS AT VARIOUS HEIGHTS ABOVE THE FLOOR AT THE RIGHT REAR CORNER OF THE ENGINEER'S SEAT IN A NORMAL REVENUE SERVICE TRAIN WHILE OPERATING ON A 1500 V DC CATENARY	4-16
4-7	STATISTICAL SUMMARY OF THE MAGNETIC FIELD LEVELS AT VARIOUS HEIGHTS ABOVE THE FLOOR AT THE RIGHT REAR CORNER OF THE ENGINEER'S SEAT IN THE CAB OF THE TEST TRAIN OPERATING ON A 25 kV, 50 Hz AC CATENARY	4-17
4-8	STATISTICAL SUMMARY OF THE MAGNETIC FIELD LEVELS AT VARIOUS HEIGHTS ABOVE THE FLOOR AT THE RIGHT REAR CORNER OF THE ENGINEER'S SEAT IN THE CAB OF A TRAIN IN NORMAL SCHEDULED REVENUE SERVICE OPERATING ON A 15 kV, 50 Hz AC CATENARY	4-19
5-1	REPETITIVE MAGNETIC FIELD WAVEFORM DATASETS MEASURED ALONG THE WAYSIDE	5-5

VOLUME I

LIST OF TABLES (CONT'D)

<u>Table</u>	<u>Page</u>
5-2 SUMMARY OF MAGNETIC FIELD LEVELS RECORDED ALONG THE WAYSIDE WITH THE DIGITAL AUDIO TAPE RECORDER (DAT)	5-17
5-3 SUMMARY OF MAGNETIC FIELD LEVELS RECORDED ALONG THE WAYSIDE OVERPASS, UNDERPASS, AND OPEN SPACE USING THE RMS RECORDERS	5-18
5-4 SUMMARY STATISTICS OF VERTICAL DATASET MEASURED ON THE OVERPASS NEAR 121 km MARKER ABOVE PARIS BOUND LINE (DATASET TGV029)	5-19
5-5 SUMMARY STATISTICS OF VERTICAL DATASET MEASURED AT THE UNDERPASS NEAR 105 km MARKER UNDER PARIS BOUND LINE (DATASET TGV030)	5-20
5-6 SUMMARY STATISTICS OF VERTICAL DATASET MEASURED ALONG WAYSIDE NEAR 104 km MARKER AT AN OPEN SPACE (DATASET TGV031)	5-21
5-7 CALCULATED DISTANCES FROM TRACK TO REACH A 1 mG MAGNETIC FIELD MAXIMUM OR AVERAGE LEVEL BASED ON CURVE FIT OF DATA FOR THREE DIFFERENT TRAIN PASSES ALONG THE WAYSIDE OPEN SPACE	5-23
5-8 ELECTRIC FIELD MEASUREMENTS ALONG A PERPENDICULAR PROFILE TO THE TRACKS ALONG THE WAYSIDE AT AN OPEN SPACE	5-23
6-1 REPETITIVE MAGNETIC FIELD WAVEFORM DATASETS MEASURED ON THE VENDOME PASSENGER PLATFORM	6-4
6-2 COMPARISON OF MAXIMUM RMS MAGNETIC FIELD LEVELS AT THE EDGE OF THE PLATFORM NEAR THE TRACKS (10 cm PROBE) AND A POINT 5 m (16.4 ft) MORE DISTANT (REFERENCE)	6-8
6-3 SUMMARY OF MAGNETIC FIELD LEVELS RECORDED AT THE PASSENGER STATION WITH THE DIGITAL AUDIO TAPE RECORDER (DAT)	6-9
6-4 STATISTICAL SUMMARY OF MAGNETIC FIELDS MEASURED ON THE PASSENGER PLATFORM USING RMS DATA RECORDERS	6-12
6-5 SUMMARY STATISTICS OF VERTICAL DATASET MEASURED ON THE VENDOME PASSENGER PLATFORM AS TRAIN FROM PARIS PASSED BY (DATASET TGV017)	6-13

VOLUME I

LIST OF TABLES (CONT'D)

<u>Table</u>	<u>Page</u>
6-6 SUMMARY STATISTICS OF VERTICAL DATASET MEASURED ON THE VENDOME PASSENGER PLATFORM AS TRAIN FROM PARIS PASSED BY (DATASET TGV018)	6-14
6-7 SUMMARY STATISTICS OF VERTICAL DATASET MEASURED ON THE VENDOME PASSENGER PLATFORM AS TRAIN TO PARIS PASSED BY (DATASET TGV019)	6-15
6-8 SUMMARY STATISTICS OF COMBINED VERTICAL DATASETS MEASURED ON THE VENDOME PASSENGER PLATFORM (DATASETS TGV017, 18 AND 19)	6-16
7-1 REPETITIVE MAGNETIC FIELD WAVEFORM DATASETS MEASURED NEAR A SUBSTATION AND AN AUTOTRANSFORMER STATION....	7-4
7-2 SUMMARY OF MAGNETIC FIELD LEVELS RECORDED NEAR A SUBSTATION AND AN AUTOTRANSFORMER STATION WITH THE DIGITAL AUDIO TAPE RECORDER (DAT).....	7-10
7-3 STATISTICAL SUMMARY OF MAGNETIC FIELDS IN mG MEASURED AT THE GAULT ST. DENIS SUBSTATION AND THE CHAILLOT AUTOTRANSFORMER USING RMS DATA RECORDERS.....	7-11
7-4 SUMMARY STATISTICS OF COMBINED VERTICAL DATASETS MEASURED AT THE GAULT ST. DENIS SUBSTATION 2 m (6.6 ft) FROM THE FENCE (DATASETS TGV032 AND 33)....	7-12
7-5 SUMMARY STATISTICS OF VERTICAL DATASET MEASURED AT THE GAULT ST. DENIS SUBSTATION INSIDE THE CONTROL HOUSE (DATASET TGV034).....	7-13
7-6 SUMMARY STATISTICS OF COMBINED VERTICAL DATASETS MEASURED AT THE CHAILLOT AUTOTRANSFORMER STATION 2 m (6.6. ft) FROM THE FENCE (DATASETS TGV027 AND 28)...	7-14
8-1 REPETITIVE MAGNETIC FIELD WAVEFORM DATASETS MEASURED IN CONTROL FACILITIES	8-4
8-2 SUMMARY OF MAGNETIC FIELD LEVELS RECORDED AT THE DISPATCHER'S SEAT INSIDE THE TGV-A CONTROL CENTER AT GARE MONTPARNASSE WITH THE DIGITAL AUDIO TAPE RECORDER (DAT).....	8-6
8-3 SUMMARY STATISTICS OF VERTICAL DATASET MEASURED IN THE TGV-A CONTROL CENTER AT GARE MONTPARNASSE IN FRONT OF THE CENTERMOST MONITOR SCREEN (DATASET TGV010)	8-9

VOLUME I

LIST OF TABLES (CONT'D)

<u>Table</u>		<u>Page</u>
8-4	SUMMARY STATISTICS OF HORIZONTAL PROFILE DATASET MEASURED IN THE TGV-A CONTROL CENTER AT GARE MONTPARNASSE FROM THE CENTERMOST MONITOR SCREEN (DATASET TGV011).....	8-10
8-5	SUMMARY STATISTICS OF VERTICAL DATASET MEASURED IN THE RELAY ROOM AT VENDOME NEAR THE AC SUPPLY CABINET (DATASET TGV015).....	8-11
8-6	SUMMARY STATISTICS OF VERTICAL DATASET MEASURED IN THE RELAY ROOM AT VENDOME BETWEEN THE RELAY CABINETS (DATASET TGV016).....	8-12
8-7	SUMMARY STATISTICS OF COMBINED VERTICAL DATASETS MEASURED IN THE RELAY ROOM AT VENDOME (DATASETS TGV015 AND 16)	8-13

VOLUME II

TABLE OF CONTENTS

<u>Section</u>		<u>Page</u>
APPENDIX A	Description of Appended Data	A-1
APPENDIX B	Dataset TGV001 - First Class Salon at Front of Coach R1B	B-1
APPENDIX C	Dataset TGV002 - First Class Salon at Front of Coach R1B	C-1
APPENDIX D	Dataset TGV003 - Axial Profile in First Class Salon at Front of Coach R1B	D-1
APPENDIX E	Dataset TGV004 - Transverse Profile in First Class Salon at Front of Coach R1B	E-1
APPENDIX F	Dataset TGV005 - Test Train Locomotive, Against Engineer's Chair	F-1
APPENDIX G	Dataset TGV006 - Test Train Locomotive, Against Engineer's Chair	G-1
APPENDIX H	Dataset TGV007 - Transverse Profile From Side Wall of Test Train Locomotive	H-1
APPENDIX I	Dataset TGV008 - Axial Profile From Rear Wall of Test Train Locomotive	I-1
APPENDIX J	Dataset TGV009 - Test Train Locomotive, Against Engineer's Chair	J-1
APPENDIX K	Dataset TGV010 - TGV Control Center in Montparnasse Station	K-1
APPENDIX L	Dataset TGV011 - Horizontal Profile From Console Monitor TGV Control Center in Montparnasse Station	L-1
APPENDIX M	Dataset TGV012 - Center of First Class Coach R2B	M-1
APPENDIX N	Dataset TGV013 - Transverse Profile From Side Wall of First Class Coach R2B	N-1
APPENDIX O	Dataset TGV014 - Axial Profile From Center of First Class Coach R2B	O-1
APPENDIX P	Dataset TGV015 - Vendome Station Relay Room Near AC Supply Cabinet	P-1

VOLUME II

TABLE OF CONTENTS (CONT'D)

<u>Section</u>		<u>Page</u>
APPENDIX Q	Dataset TGV016 - Vendome Station Relay Room Between Two Rows of Relay Shelves	Q-1
APPENDIX R	Dataset TGV017 - Vendome Station Platform as Train From Paris Passed	R-1
APPENDIX S	Dataset TGV018 - Vendome Station Platform as Train From Paris Passed	S-1
APPENDIX T	Dataset TGV019 - Vendome Station Platform as Train To Paris Passed	T-1
APPENDIX U	Dataset TGV020 - Center of Second Class Coach R5B	U-1
APPENDIX V	Dataset TGV021 - Center of Second Class Coach R5B	V-1
APPENDIX W	Dataset TGV022 - Transverse Profile From Side Wall of Second Class Coach R5B	W-1
APPENDIX X	Dataset TGV023 - Axial Profile From Center of Second Class Coach R5B	X-1
APPENDIX Y	Dataset TGV024 - Center of Second Class Coach R5B	Y-1
APPENDIX Z	Dataset TGV025 - Revenue Train Locomotive, Against Engineer's Chair	Z-1
APPENDIX AA	Dataset TGV026 - Revenue Train Locomotive, Against Engineer's Chair	AA-1
APPENDIX AB	Dataset TGV027 - At Chaillot Autotransformer ..	AB-1
APPENDIX AC	Dataset TGV028 - At Chaillot Autotransformer ..	AC-1
APPENDIX AD	Dataset TGV029 - Overpass	AD-1
APPENDIX AE	Dataset TGV030 - Underpass	AE-1
APPENDIX AF	Dataset TGV031 - Wayside Near 104 km Marker ...	AF-1
APPENDIX AG	Dataset TGV032 - Behind Gault St. Denis Substation	AG-1

VOLUME II

TABLE OF CONTENTS (CONT'D)

<u>Section</u>	<u>Page</u>
APPENDIX AH Dataset TGV033 - Behind Gault St. Denis Substation	AH-1
APPENDIX AI Dataset TGV034 - Inside Control House at Gault St. Denis Substation	AI-1

VOLUME II
LIST OF FIGURES

<u>Figure</u>		<u>Page</u>
A-1	CAR R1-FIRST CLASS, CAR R2-FIRST CLASS CLUB COACH, CAR R5-SECOND CLASS COACH	A-11
A-2	FIRST LOCOMOTIVE OF TEST TRAIN, FIRST LOCOMOTIVE OF REVENUE TRAIN	A-12
A-3	TGV CONTROL CENTER IN PARIS (MONTPARNASSE STATION)	A-13
A-4	RELAY ROOM VENDOME STATION	A-14
A-5	VENDOME STATION	A-15
A-6	AUTO-TRANSFORMER STATION CHAILLOT AT MARKER 120.875 km	A-16
A-7	HIGHWAY OVERPASS	A-17
A-8	HIGHWAY UNDERPASS	A-18
A-9	WAYSIDE MEASUREMENT AT MARKER 104 km	A-19
A-10	GAULT ST. DENIS SUBSTATION	A-20

VOLUME II
LIST OF TABLES

<u>Table</u>		<u>Page</u>
A-1	INDEX OF REPETITIVE WAVEFORM DATA FRENCH TGV SEPTEMBER 8-SEPTEMBER 9, 1992	A-4

1. EXECUTIVE SUMMARY

This report documents the low frequency electric and magnetic fields associated with the operation of the French Train a Grande Vitesse-Atlantique (TGV-A). With excellent cooperation and assistance of the personnel of the French National Railroads (SNCF), comprehensive measurements were made on the train and along the route between Paris and Tours, France.

Figure 1-1 depicts the general route of the TGV-A. Magnetic and electric field measurements were made on the portion from Montparnasse Station in Paris to St. Pierre des Corps Station near Tours. The approximate locations where off-train measurements were made are also indicated.

1.1 BACKGROUND

Prior to conducting the measurements and analysis reported in this document, extensive measurements have been made and were reported for two other electrified rail systems^{1,2,3}. Similar but less extensive measurements were made on the Transrapid TR07 Maglev System at the test track in Emsland, Germany. Extensive measurements were made in the United States on the train systems that make up the Northeast Corridor (NEC) and on a New Jersey Transit Line.

The motivation for these extensive measurements was to enable a comparison of TGV-A electric and magnetic field characteristics with the findings of the Maglev study. While Maglev magnetic field magnitudes were within the range of other well documented sources of magnetic fields, the temporal characteristics differed. The previously well documented sources were transmission and distribution lines which are largely a single frequency source. Magnitude comparisons only of such temporally different sources are not appropriate for the multi-frequency and complex time characteristics found associated with the Maglev operation. To have data to fairly assess the electric and magnetic fields from any newly-electrified rail system installed in the United States, the FRA research program sponsored a measurement program to fully quantify four existing electrified rail systems. These include the TGV, along with the NEC and data yet to be reported on the Washington, DC Metro and the Boston Metro. With such a basic electric and magnetic field dataset, obtained by similar equipment and test approach, more appropriate comparisons can be made.

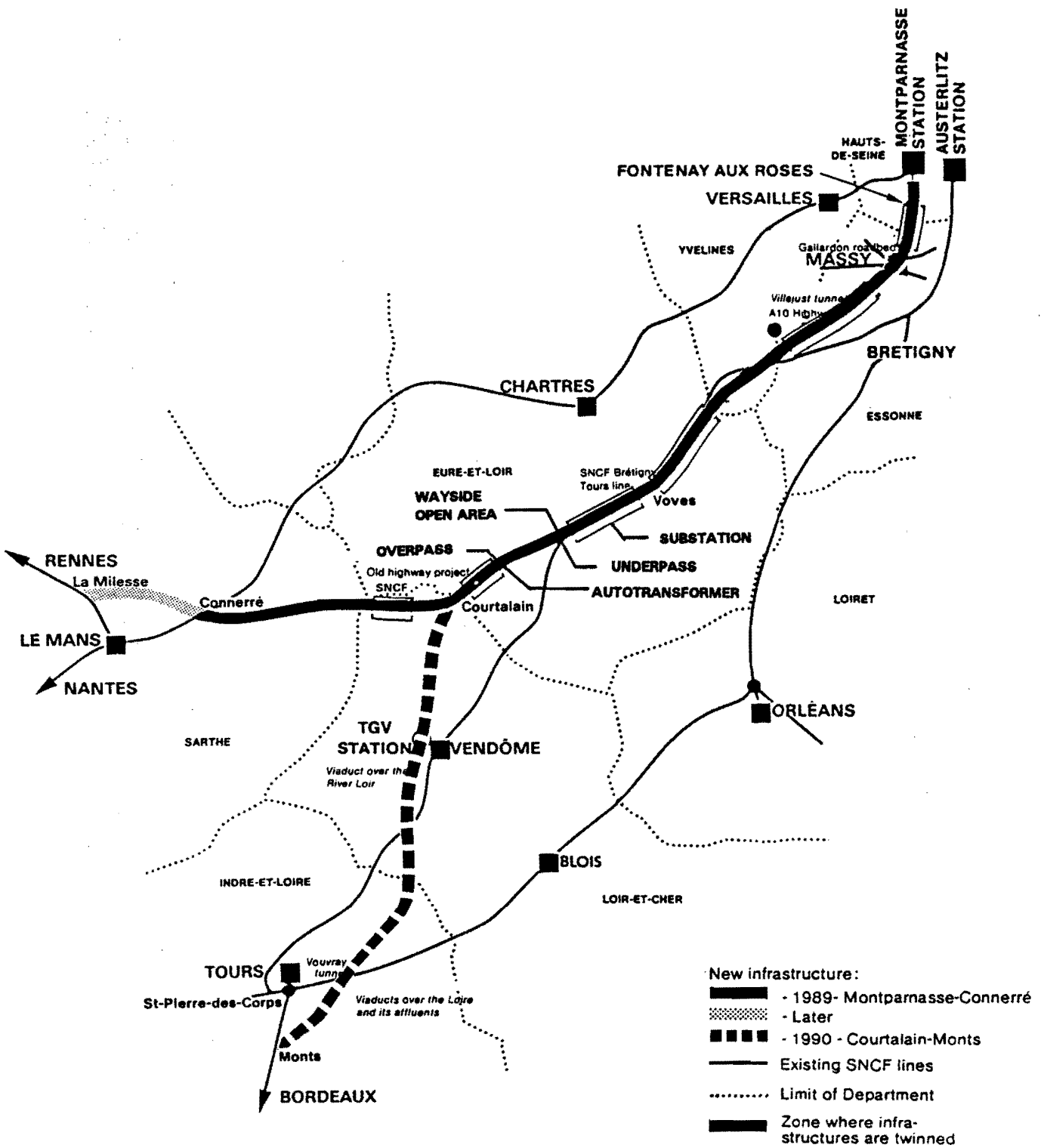

FIGURE 1-1. ROUTE OF THE TGV ATLANTIQUE WITH LOCATIONS OF WAYSIDE, AUTOTRANSFORMER AND SUBSTATION MEASUREMENT

1.2 MEASUREMENT APPROACH

All of the electric and magnetic field measurements were made using the *MultiWave*™ System instrumentation package originally developed under sponsorship of the Electric Power Research Institute (EPRI). The measurement system was repackaged for portability to make the measurements reported in this study. This system quantifies both the spatial and temporal characteristics of the magnetic field. By recording the actual waveform of the magnetic field with sensors having frequency responses from 0 to 3 kHz, the *MultiWave*™ System (hereinafter referred to as the waveform capture system) makes it possible to examine the temporal characteristic throughout the ELF band. (The reader who is unfamiliar with basic terms like "Hz" and "ELF" is encouraged to review the conversion table in the front of this report.) For the NEC and the TGV-A measurements, the waveform capture system also recorded the electric field at head height. Also for the NEC and TGV-A measurements, the waveform capture system data was complemented by recording on a TEAC Model RD 130 T digital audio tape (hereinafter referred to as DAT) to capture transient events and with two personal dosimeters which record the root mean square (rms) of the magnetic field. These personal exposure recorders were EMDEX-II's (hereinafter referred to as "rms recorders") and were normally worn at belt height by the test personnel.

The magnetic field and electric field measurements associated with the TGV-A operation were grouped into four areas. They were onboard the trains, in the passenger stations, along the track rights-of-way, and near the substations which supply power to rail system.

Onboard the train measurements were made in the passenger coaches and in the engineer's cab.

At the stations, electric and magnetic field measurements were taken at both ends of the platforms at points nearest the track where a person could reasonably stand.

Wayside measurements were made to quantify the field environment in areas open to the general public. Wayside refers to the public accesses along the system of track rights-of-way. Field measurements were made with no trains on the track and during times of passing trains.

Power substation measurements were made near the substation fences and under the connected transmission lines.

1.3 SUMMARY OF TGV-A FIELD LEVELS

The following is a concise description of the time varying magnetic field characteristic found in each of the areas examined. Electric fields are only mentioned for those areas where fields above ten volts per meter (10 V/m) were found.

fields are only mentioned for those areas where fields above ten volts per meter (10 V/m) were found.

1.3.1 Coaches

The magnetic fields in coaches arise mainly from the traction power current which flows in the catenaries, tracks, and a 25 kV ac single phase cable in the roof of the coaches. These are the principal sources of time varying magnetic fields within the coaches. There are hotel power cables, both ac and dc, that interconnect the coaches. A 1500 volt dc cable under the coaches interconnects the push-pull locomotives during dc track operation.

The static magnetic field in the dc powered section of the line, as measured by the waveform capture system, averaged 913 mG over all samples and all sensor locations. The maximum static field encountered during the same periods was 3066 mG.

Correspondingly, the 50 Hz power frequency component of the magnetic field was the largest component in the coaches while the train was in the ac powered section of the line. It averaged 31 mG over all samples and all sensor locations. The maximum ac magnetic field encountered during the same periods was 165 mG. The magnetic field components in the 5 to 45 Hz sub-band were comparable, with an average of 23 mG and a maximum of 106 mG.

Overall, the magnetic field was relatively uniform throughout the coaches and had frequency components consistent with the main power supply frequency and its harmonics.

1.3.2 Locomotive (Power Car) Cabs

The principal source of magnetic field in the engineer's cab is the current in the catenary and track circuit perhaps augmented by fields from current circuits passing through the locomotive, such as the 25 kV cabling, circuit breaker and transformer connections. The following summary values are obtained close to the engineer's seat. The magnetic field of the power frequency band is relatively spatially uniform from side to side but shows a consistent spatial gradient in the axial direction. This axial spatial gradient may be caused by close proximity to structural steel in the cab.

The static magnetic field in the dc powered sections of the track averaged 815 mG over all samples and all sensor locations. The maximum static field encountered during the same periods was 2580 mG.

Correspondingly, the power frequency range magnetic field in the ac powered sections of the track averaged 87 mG over all samples and all sensor locations. The maximum ac magnetic field encountered during the same periods was 367 mG.

Overall, the magnetic field had frequency components consistent with the main power supply frequency and its harmonics.

1.3.3 Railroad Waysides

The magnetic field at the wayside of electrified railroads arises almost exclusively from the current in the catenary and tracks. These fields are functions of both the load of the nearby circuits, within the electrification sector, and the distance from them. As a train leaves the electrification sector between autotransformers, the magnetic field becomes considerably smaller. Moreover, the magnetic field at the railroad wayside attenuates rapidly with distance from the tracks.

The largest power frequency magnetic fields measured were on an overpass because the probes were closest to the catenaries, approximately 4 m (13.1 ft) below. The average magnetic field was 118 mG at the overpass. Correspondingly, the maximum measured magnetic field was 467 mG at the overpass. At underpasses and in open spaces the average magnetic fields were 1.7 and 7.2 mG, respectively. The maximum values measured at the underpass and open space were 8.7 and 24 mG, respectively.

The electric fields measured at the open space along the wayside are due to the catenary and the feeder conductor. The highest measured electric field was 385 V/m at 7.5 m (24.6 ft) from the tracks.

1.3.4 Passenger Station Platforms

The magnetic field environment on the open passenger station platform is similar to the wayside, except that the rider is closer to the train, its power catenaries and tracks, but not as close as the overpass. The average 50 Hz magnetic fields measured at the platform were 5.9 mG, considering all samples and at all heights, for trains going in both directions. The maximum value was 43.8 mG.

1.3.5 Electric Power Supply Stations

Only modest strength power frequency magnetic fields were observed at 2 m (6.6 ft) outside the fence of power supply stations. The measured average 50 Hz magnetic fields were 5.0 mG at the substation and 3.4 mG at the autotransformer location. The corresponding measured maximum 50 Hz magnetic fields were 9.0 mG at the substation and 12.6 mG at the autotransformer location. The magnetic field levels inside the substation control house were larger, namely 10.9 mG for the measured average and 34.3 mG for the measured maximum, but that is as expected due to the proximity to current circuits.

The electric fields measured at the substation and autotransformer yard are due to the entering and exiting transmission lines and conductors. The highest measured electric field was 817 V/m at 4 m (13.1 ft) from the fence on the high voltage side of the substation.

1.3.6 Control Facilities

The major source of power frequency magnetic fields is the current in the power supply to the equipment. The measured average 50 Hz magnetic fields were 0.91 mG in the TGV-A control room and 0.36 mG in the relay room. The corresponding measured maximum 50 Hz magnetic fields were 3.10 mG in the TGV-A control room and 2.81 mG in the relay room.

1.4 COMPARISON OF TGV-A FIELDS TO OTHER ELECTRO-TECHNOLOGIES

Much of the concern about ELF magnetic field levels is driven by uncertainty as to whether such fields exert an adverse effect on human health. Existing scientific knowledge provides no sound insight as to what aspects of ELF magnetic exposure, if any, are of biological concern⁴. Consequently, public acceptance of magnetic field exposures is presently based more on equity and comparability to other exposures than to quantifiable characteristics of the field itself. Therefore, this section compares and contrasts the magnetic fields produced by TGV-A operation to other sources of magnetic fields.

1.4.1 Static Fields

"Static" or dc fields are caused by dc current flowing in nearby conductor systems. Static magnetic fields beyond normal perturbation of the earth's geomagnetic field exist inside the coaches and the locomotives while operating in the dc portion of the railroad line. While these static field levels fluctuate in intensity in response to traction power needs of the train, they are considered static in this report because the time periods of their fluctuation are long (> 2 seconds) compared to the field sampling period. The maximum static value recorded was approximately three times perturbed levels found in commercial buildings or approximately six times the ambient geomagnetic field.

1.4.2 Frequency Spectrum

The frequency characteristics of the magnetic fields onboard or near the TGV-A high speed line are similar to those near many electrical power systems and appliances. The main component of the magnetic field is the fundamental of the 50 Hz power frequency. Onboard the coaches there is nearly comparable magnetic field energy in the 5 to 45 Hz sub-band which is different from most

power system and appliance magnetic fields. In all other measurement areas the power frequency field dominates with some energy in its odd harmonics.

1.4.3 Time Characteristics

The magnetic fields onboard the TGV-A trains or near the TGV-A tracks have pronounced temporal variability similar to the variability of magnetic fields near appliances with varying load or intermittent use. These fields have much greater variability than the fields found near most commercial electric power lines.

1.4.4 Amplitude Characteristics

This subsection compares the measured total ELF field levels onboard the TGV-A trains or near the electrified TGV-A rail line and its facilities to the reported environmental field levels from various power frequency sources, without adjustment for the 50 to 60 Hz difference. Since little data exist on specific frequency characteristics which match the comprehensiveness of the TGV-A data, the reader is cautioned that the following is not a quantitative analysis.

1.4.4.1 Coaches - Figure 1-2 (Figure 9-4 in the Conclusions) shows the range of total time varying magnetic fields measured in the coaches on the TGV-A train as a function of distance from the source (track and catenary). The range is plotted over the graph of a typical power line and appliance field levels⁴. As the graph illustrates, the intensity of the ELF magnetic field inside the coaches is nearly independent on the distance from the tracks or the catenaries. The range of magnetic field intensities spans more than two orders of magnitude, including the range of magnetic fields found under distribution lines or transmission lines. However, fields of comparable or greater intensity are found close to appliances.

1.4.4.2 Locomotive Cabs - Figure 1-3 (Figure 9-5 in the Conclusions) shows the range of total time varying magnetic fields recorded in the TGV-A locomotive cabs as a function of distance from the catenary. The data are plotted over the same typical power frequency magnetic field levels. The magnetic field levels in the locomotive cabs are within the range of field levels found beneath electric power lines or near appliances.

1.4.4.3 Along the Wayside - The time varying magnetic field at the wayside attenuates away from the catenary and tracks. The rate is near the theoretical rate of attenuation of current flowing in opposite directions in two long parallel wires, i.e., proportional to the reciprocal of the square of the distance. Figure 1-4 (Figure 9-6 in the Conclusions) shows the plot of the ranges

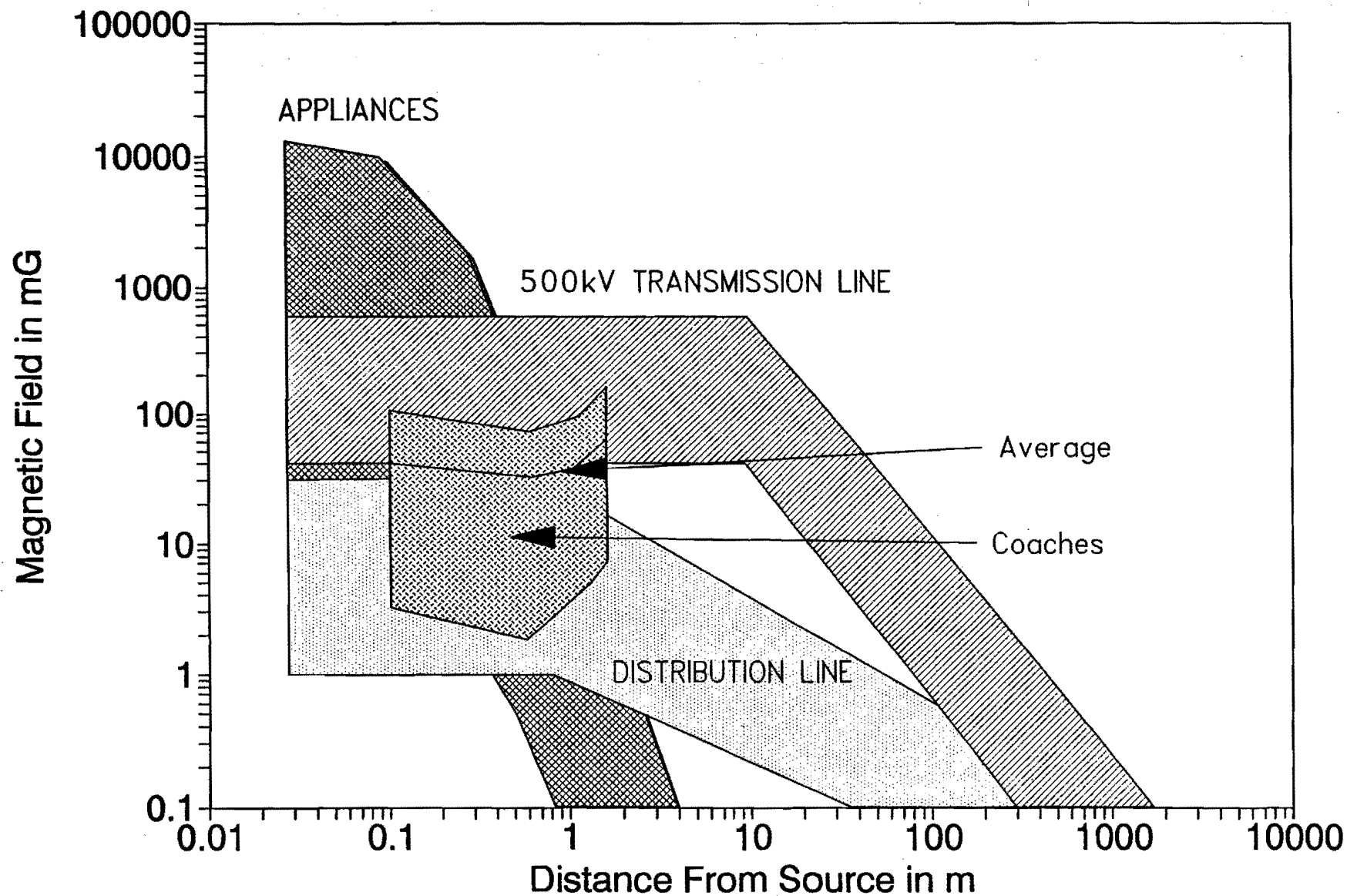

FIGURE 1-2. THE RANGE OF TOTAL TIME VARYING MAGNETIC FIELD LEVELS IN THE TGV-A PASSENGER COACHES AT VARIOUS HEIGHTS ABOVE THE FLOOR COMPARED TO TYPICAL LEVELS OF POWER-FREQUENCY MAGNETIC FIELDS PRODUCED BY COMMON SOURCES AT VARIOUS DISTANCES FROM THE SOURCE

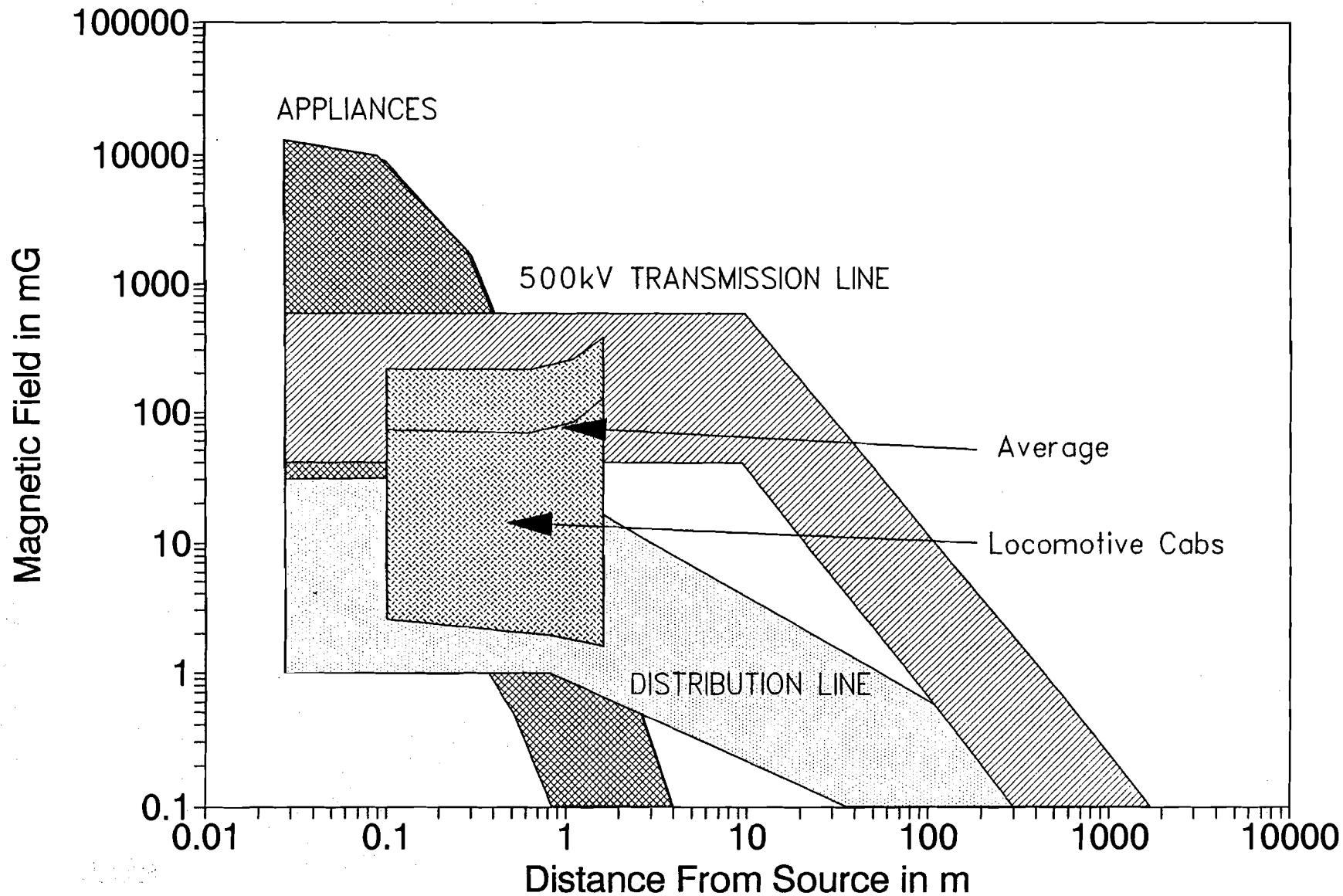

FIGURE 1-3. THE RANGE OF TOTAL TIME VARYING MAGNETIC FIELD LEVELS IN THE TGV-A LOCOMOTIVE CABS AT VARIOUS HEIGHTS ABOVE THE FLOOR COMPARED TO TYPICAL LEVELS OF POWER-FREQUENCY MAGNETIC FIELDS PRODUCED BY COMMON SOURCES AT VARIOUS DISTANCES FROM THE SOURCE

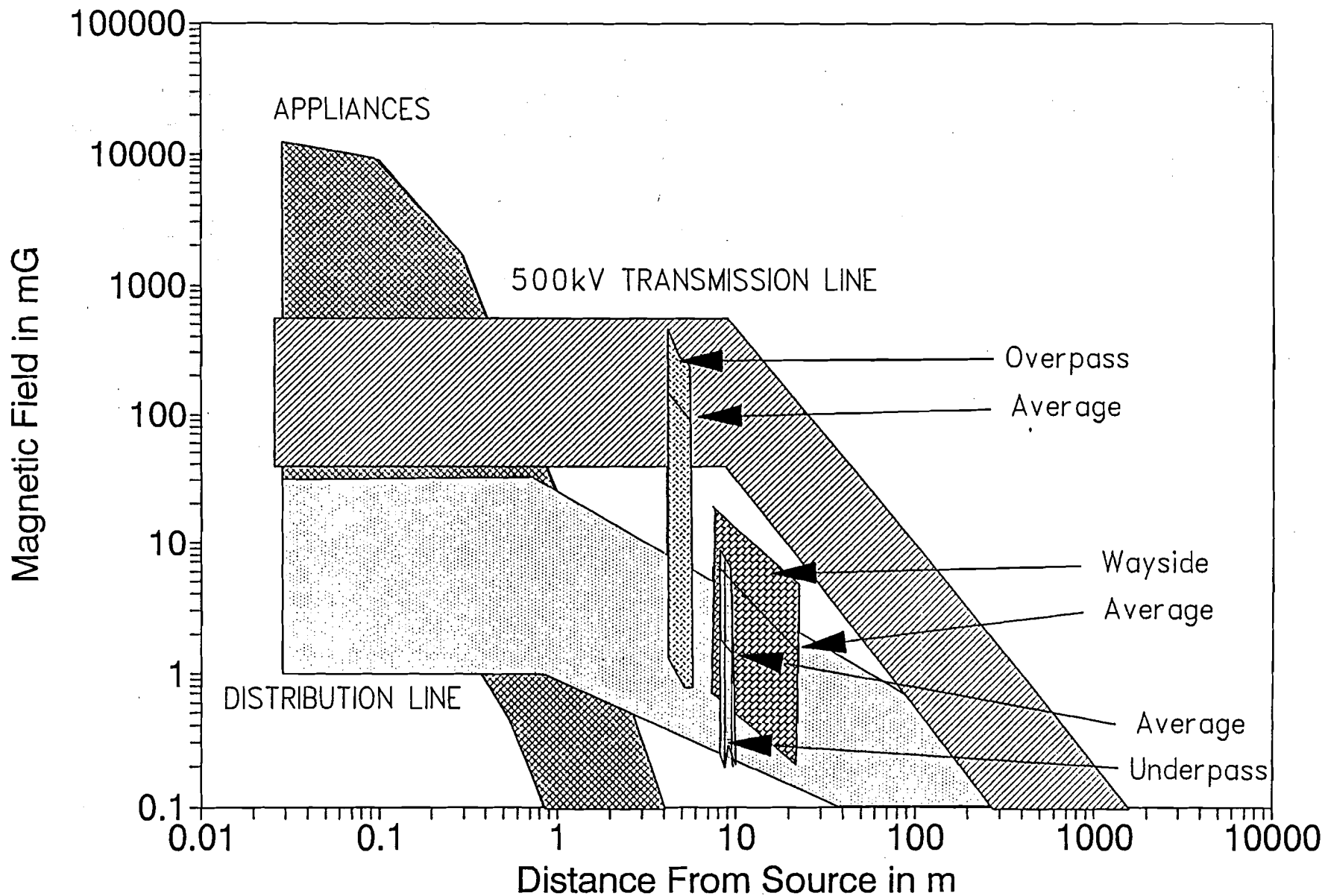

FIGURE 1-3. THE RANGE OF TOTAL TIME VARYING MAGNETIC FIELD LEVELS IN THE TGV-A LOCOMOTIVE CABS AT VARIOUS HEIGHTS ABOVE THE FLOOR COMPARED TO TYPICAL LEVELS OF POWER-FREQUENCY MAGNETIC FIELDS PRODUCED BY COMMON SOURCES AT VARIOUS DISTANCES FROM THE SOURCE

corresponding to the three measurement locations, namely the overpass, the underpass and the open space along the wayside. The distance to the source for the overpass and the underpass is measured to the catenary. The distance for the open space is measured to the tracks. The figure shows that the range of magnetic field levels at the wayside, at various distances from the track or catenary, are in the general range of magnetic fields near power lines, including distribution lines and moderate-sized transmission lines.

The measured electric field attenuation curve is superimposed on the graph of commonly-encountered electric fields in Figure 1-5 (Figure 9-7 in the Conclusions)⁴. This is an maximum boundary in that the minimum electric field can extend to near zero, if shielding objects such as trees and tall vegetation are present. The range of electric field values is seen to span the range for electric distribution lines and moderate-sized transmission lines.

1.4.4.4 Passenger Stations - The ranges of time varying magnetic fields measured in the Vendome passenger station are shown in relation to other sources in Figure 1-6 (Figure 9-8 in the Conclusions). Magnetic field levels at the platform are in the general range of magnetic fields near distribution lines.

1.4.4.5 Substations and Autotransformers - The range of total time varying magnetic fields recorded 2 m (6.6 ft) outside the fence of the Gault St. Denis electric power supply substation was comparable to field found under distribution lines.

The time varying magnetic fields recorded 2 m (6.6 ft) outside the fence of the Chaillot autotransformer station were also within the range of field levels found beneath electric distribution lines or near appliances.

The measured electric field attenuation curves are superimposed on the graph of commonly encountered electric fields in Figure 1-7 (Figure 9-11 in the Conclusions). This is a maximum level since the minimum electric field can extend to near zero when shielding vegetation is present. The range of the electric field is seen to span the range of electric fields produced by electric distribution lines and high voltage transmission lines.

1.4.4.6 Control Center - Figure 1-8 (Figure 9-12 in the Conclusions) shows the plot of the range of time varying magnetic fields in front of the dispatcher's video display terminal in the TGV-A control room. The distance to the source is the distance to the VDT screen. The figure shows that the range of magnetic field levels in the TGV-A control room are under the range of magnetic fields near distribution lines and in the same range as appliances.

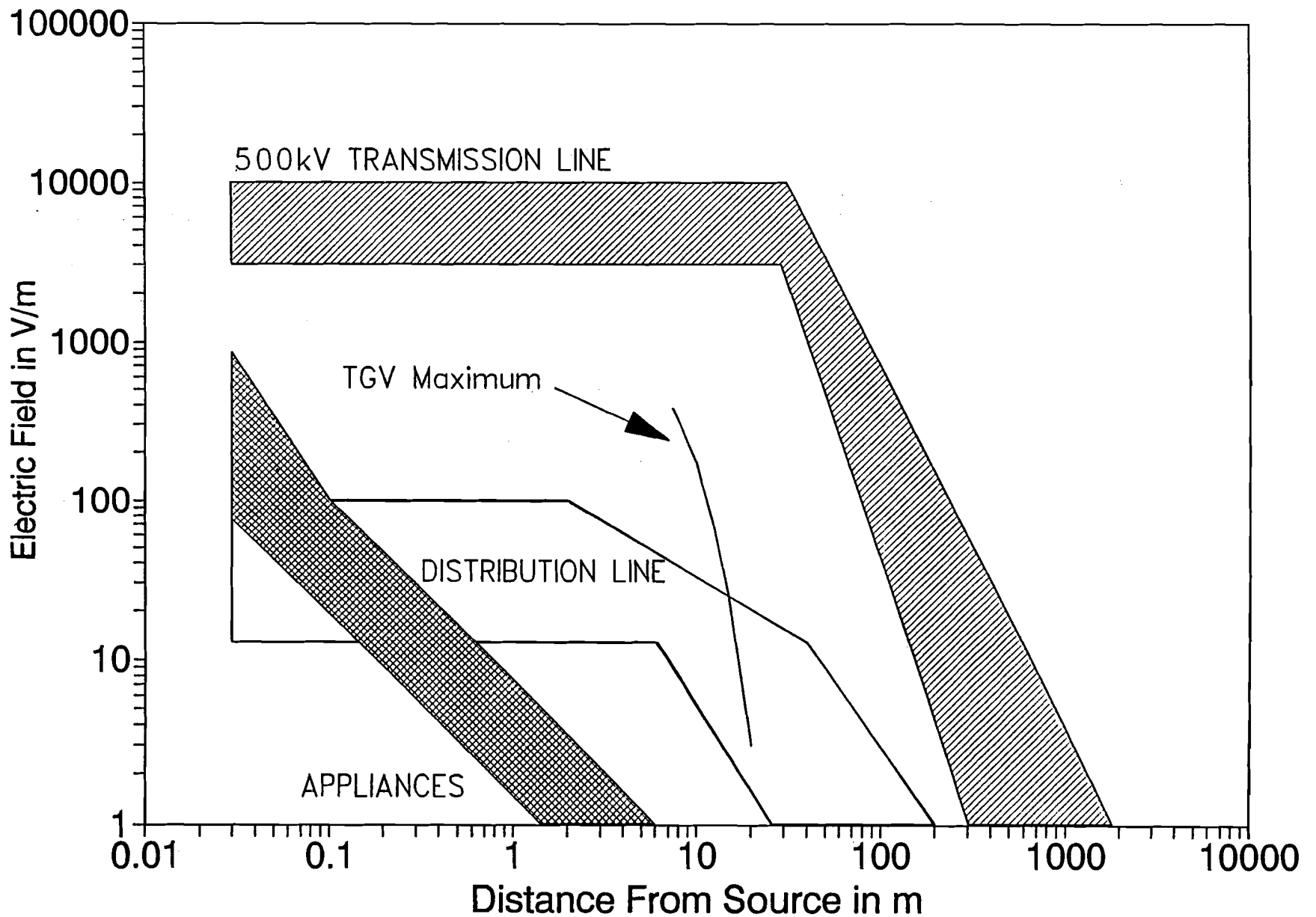

FIGURE 1-5. MAXIMUM TIME VARYING ELECTRIC FIELD AT THE WAYSIDE OF THE TGV-A ELECTRIFIED RAILROAD AS A FUNCTION OF DISTANCE FROM THE NEAREST TRACK COMPARED TO TYPICAL LEVELS OF POWER-FREQUENCY ELECTRIC FIELDS PRODUCED BY COMMON SOURCES

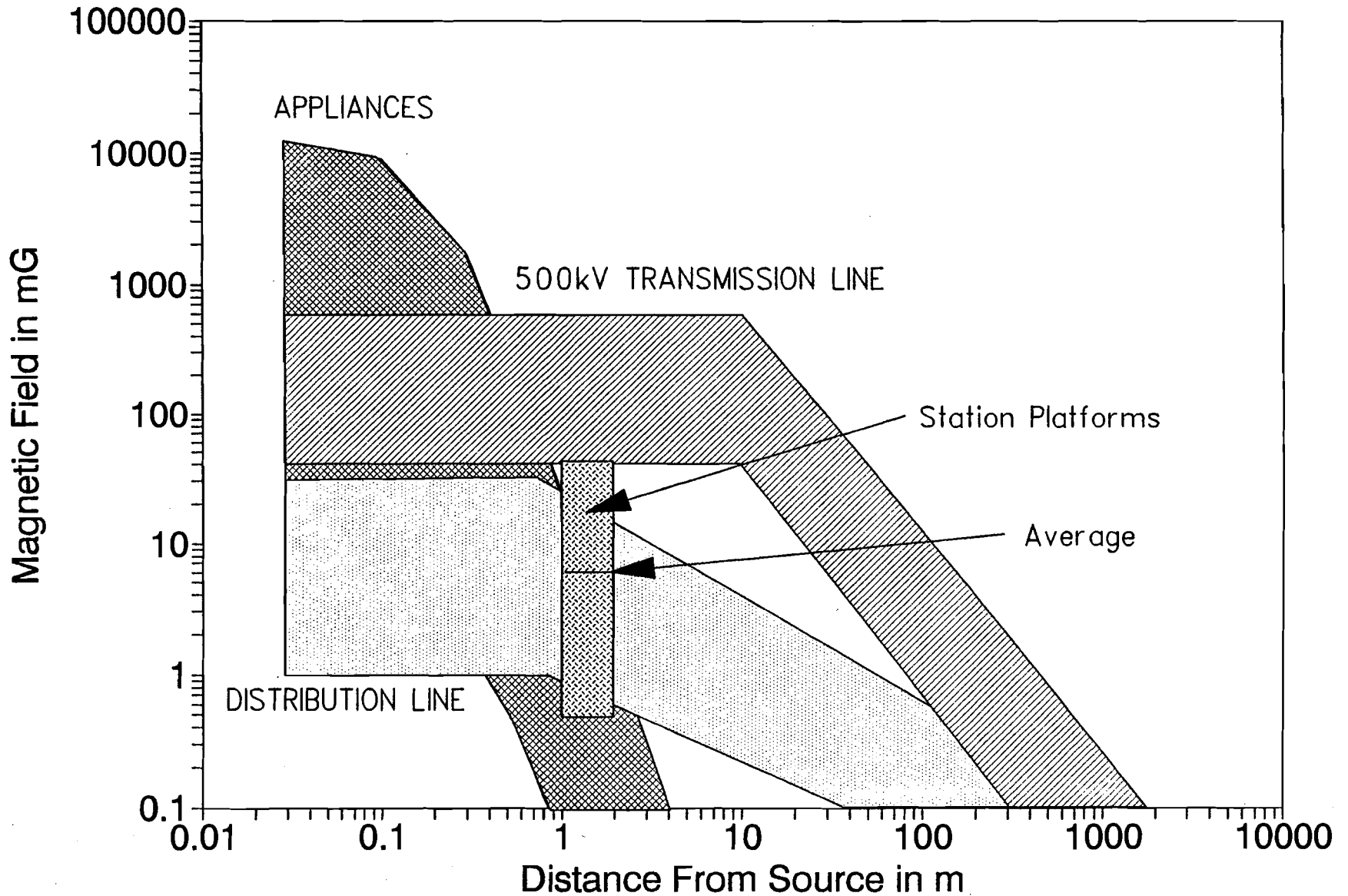

FIGURE 1-6. THE RANGE OF TOTAL TIME VARYING MAGNETIC FIELD LEVELS ON THE VENDOME STATION PLATFORM APPROXIMATELY 1.5 m (5 ft) FROM CENTERLINE OF THE NEAREST TRACK COMPARED TO TYPICAL POWER-FREQUENCY MAGNETIC FIELD LEVELS FROM COMMON SOURCES

1-14

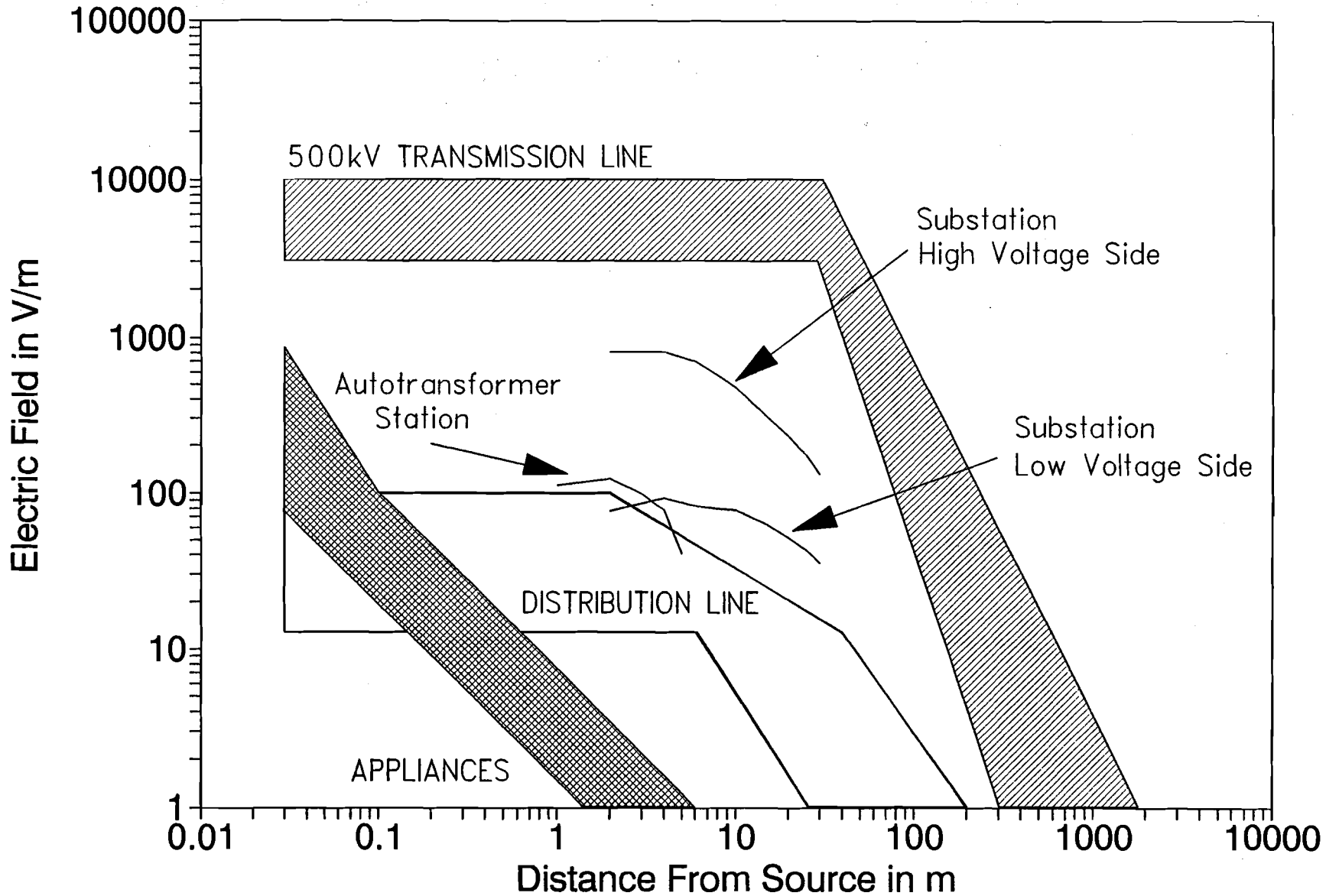

FIGURE 1-7. MEASURED TOTAL TIME VARYING ELECTRIC FIELD AT SUBSTATION LOW AND HIGH VOLTAGE SIDES AND AUTOTRANSFORMER STATION AS A FUNCTION OF DISTANCE FROM FENCE, COMPARED TO TYPICAL POWER-FREQUENCY ELECTRIC FIELD LEVELS FROM COMMON SOURCES

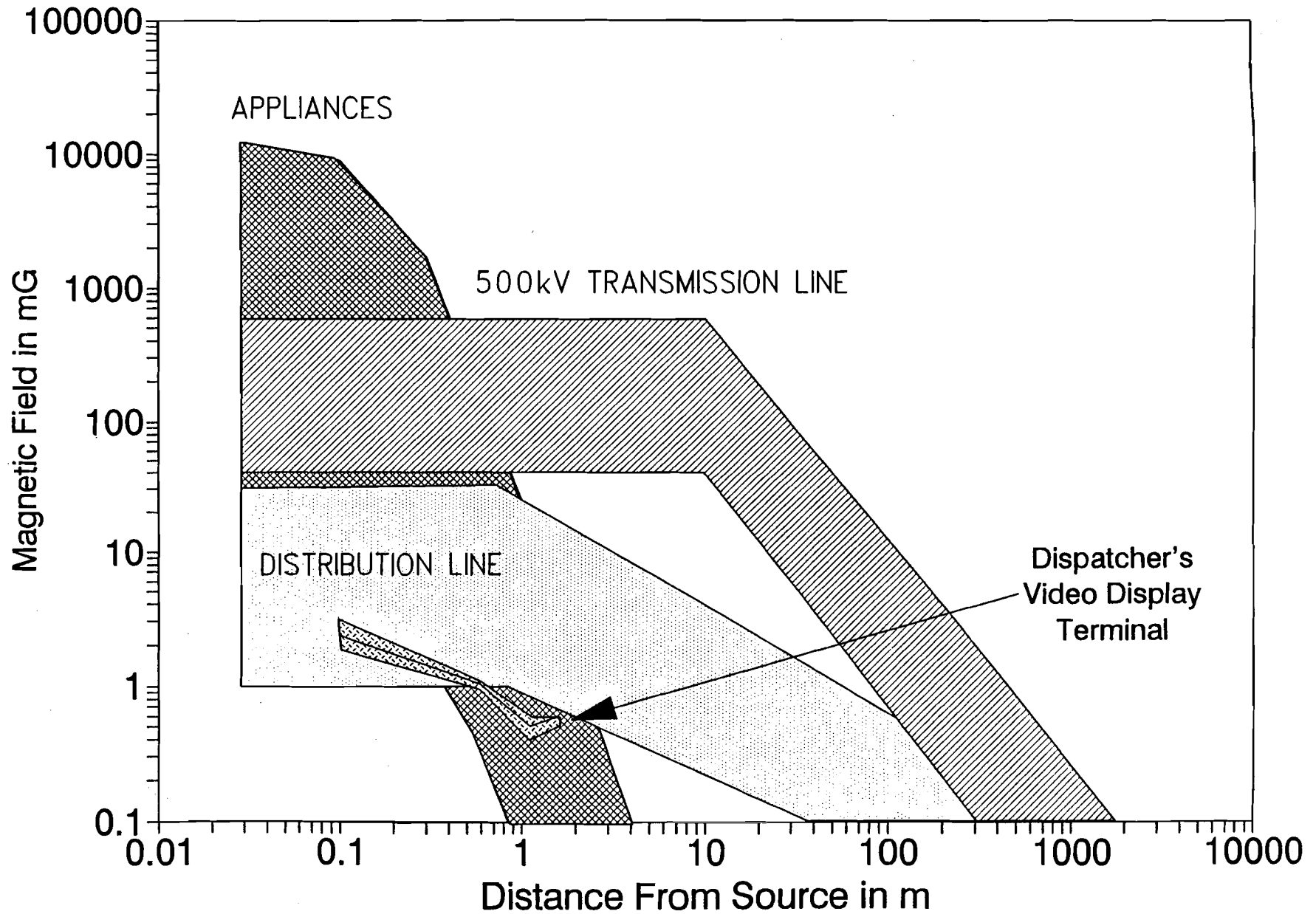

FIGURE 1-8.

THE RANGE OF TOTAL TIME VARYING MAGNETIC FIELD LEVELS IN FRONT OF A DISPATCHER'S VIDEO DISPLAY TERMINAL COMPARED TO TYPICAL POWER-FREQUENCY MAGNETIC FIELD LEVELS FROM COMMON SOURCES

1.5 CONCLUSIONS

This report presents the results of the analysis of extensive measurements of magnetic and electric fields within the coaches and locomotives, along the wayside, at passenger stations, near electric power supply stations and inside control facilities of the TGV-A rail system in France.

The time varying magnetic fields at most locations on the trains, the platforms, or along the wayside arise predominantly from current in the catenary, feeder circuit and track. The power distribution within the trains consists of conductors in the roof and under the floor in the coaches and locomotives. Because power needs of the locomotive are set by terrain and speed control, these fields are highly variable over time. The odd harmonics of the power frequency follow the same temporal variation. The magnitudes and frequency characteristic of the magnetic fields reported during ac operation were in the same range as those found under distribution lines or near appliances.

The static magnetic field at all outside locations is the natural geomagnetic field of the earth. However, the static field inside the coaches and locomotive is highly variable while the train is operating in the dc portion of the track.

Significant electric fields were detected only outside electric equipment installations, such as substations and autotransformers and at the wayside. The higher levels occurred closest to the substation high voltage lines. No significant electric fields were detected inside the locomotive or the coaches, as expected, because of the shielding by the train metallic bodies.

2. OVERVIEW

This report presents quantitative data on the low frequency (0 to 3000 Hz) electric and magnetic fields associated with the French *Train à Grand Vitesse-Atlantique* (TGV-A). It is one of a series of reports by Electric Research & Management, Inc. (ERM) for the Federal Railroad Administration (FRA) on the general characteristics of magnetic and electric fields associated with railroad systems. The previous reports have covered a number of different technologies. Specifically, measurements have been made and reported on the German Transrapid (TR07) Maglev System, onboard AMTRAK standard (Diesel) and electrified trains and near the facilities of the Northeast Corridor (NEC), and onboard trains and near the facilities of New Jersey Transit's North Jersey Coast Line from Matawan to Long Branch.

2.1 REPORT ORGANIZATION

The results of the study are organized into two volumes. Volume I focuses on representative data which demonstrates the general characteristics of the magnetic fields on or in the vicinity of the TGV-A electrified railroad and presents summary statistical data. The extensive appendices of Volume II detail the magnetic fields on or near the TGV-A electrified railroad for the reader looking for specific details of field characteristics.

The first section of this report is an Executive Summary intended for the less technically inclined reader. It describes the magnetic fields produced by the TGV-A System and the conclusions reached by these measurements in language which avoids engineering jargon to the greatest extent practical. In spite of its non-technical nature, it is recommended to all readers as an orientation to the report contents and will assist the technical reader in critically examining the contents of the report.

This section is an overview describing the report structure in more detail and directing the reader to other sources of relevant information not contained herein. It also provides some background information about the measurement program, describes instrumentation, explains the significance of the repetitive waveform data, the method of analysis, the format of data presentation, and tabulates data files by location in the field, with reference to Appendices in Volume II.

Sections 3 through 8 focus on the characteristics of the magnetic fields measured onboard the coaches, within the engineer's areas, along the wayside, at passenger stations, near power supply facilities, and at control facilities, respectively.

The ninth section of the report summarizes the magnetic field characteristics of the TGV-A electrified railroad and compares the characteristics of those fields to magnetic fields produced by other common sources.

2.2 BACKGROUND

The increasing public awareness of the controversy over possible health implications of exposure to power frequency magnetic fields makes it desirable to quantify the magnetic fields associated with use or operation of all electrical apparatus including transportation sources. Previous measurements have characterized the magnetic fields onboard the TR07 magnetically levitated vehicle and near associated facilities. Similar measurements have been made on board AMTRAK electrified trains and near the facilities of the Northeast Corridor (NEC) to provide baseline magnetic field data on a conventional, historically well accepted transportation technology against which the magnetic field environment of emerging technologies may be compared. Additional magnetic field measurements have been made onboard trains and adjacent to facilities of New Jersey Transit's North Jersey Coast Line from Matawan to Long Branch. That section of the railroad is electrified using somewhat newer technology. Other reports will quantify urban electrified rail systems in the Washington, DC and Boston Metro areas. This study concentrates on the characteristics of the French TGV-A System (*Train à Grande Vitesse*) electrified railroad, which holds the world's speed record of 515.3 km/h (320 mph).

To achieve the goal of fully quantifying the electromagnetic environment of the TGV-A electrified railroad, an exhaustive set of measurements was made onboard trains, in the engineer's areas, at passenger stations, along the wayside, in control facilities, and near power supply facilities. These measurements were made for a sampling of operating conditions. However, before the amplitude, time, and frequency characteristics of the fields are analyzed and presented, it is necessary to discuss some general background information on magnetic fields.

2.2.1 Geomagnetic Field Characteristics

The earth's naturally-occurring geomagnetic field is generally considered to be static, i.e., not variable over time (in some literature, static fields are referred to as dc fields). The earth's field is normally static at levels between 240 milligauss in Southern Brazil to 670 milligauss at the magnetic South Pole. In any region of the earth's surface, fluctuations will occur during solar magnetic disturbances. These fluctuations normally have frequencies that are less than one hundredth of a cycle per second to as high as 1000 cycles per second. The magnitude of these fluctuations is normally largest at the lowest frequencies and in the polar regions. Mid-latitude variations of 2 to 4

milligauss are common during strong solar storms. In polar regions, solar magnetic disturbances will exceed ± 20 milligauss fluctuations. Therefore, the natural environment is made up of magnetic fields with both spatial and temporal characteristics.

2.2.2 Technological Magnetic Field Perturbations

Man-made ferromagnetic structures and electro-technologies perturb these natural fields. In close proximity to building and vehicle steel, increases or decreases to the earth's unperturbed geomagnetic field of two-to-one are readily observed. Any electrical device that draws significant current for operation or uses magnetic material will create magnetic field intensities close to the device that are in the order of the naturally occurring magnetic fields. Most electrical devices in common usage are powered by alternating current (ac) sources. The magnetic fields produced have the frequency of the power source and tiny harmonics (sub or super) which result from the device's operating characteristics. On the North American continent, the dominant power source frequency is 60 cycles per second (the engineering and scientific communities have agreed to refer to cycles per second as hertz and to further shorten the reference by using the abbreviation Hz). In Europe most power systems operate at 50 Hz, which is the case for the TGV-A. Therefore, most electro-technology magnetic fields produced are primarily at these power frequencies. The magnitudes of the magnetic fields at the power frequencies range from fractions of milligauss in rural residences to tens of gauss near high-current-carrying conductors found in many commercial and industrial facilities. Many commonly-used household appliances such as high speed hair dryers and handheld drills exhibit power frequency magnetic fields well above 1 gauss (one thousand mG) in close proximity to the appliance.

2.2.3 Electric and Magnetic Fields and Biological Effects

Since the late 1800s, electro-technologies have been perturbing the natural electromagnetic environment. In the early 1970s, the subject of electric fields surfaced as a possible health concern when electric utilities tried to gain rights-of-way for power transmission lines. Transmission lines were one of a small number of electro-technologies that produced strong power frequency electric fields where there is public access. The transmission lines at the center of the controversy were a new technology in that the operating voltage was 60% higher than previous design. The frequency characteristics were unchanged. While magnetic fields were raised as a biological issue in the 1970s because of a Navy submarine communications project, it was not until 1979 that magnetic fields appeared as a possible health concern. It was suggested that there was a weak correlation with an increased risk of childhood leukemia for populations living near distribution lines. While the first such study was considered to be technically flawed, two subsequent, improved epidemiological studies continued to find a consistent pattern when a surrogate for magnetic fields,

power lines with large conductors and proximity to the cases, were documented^{5,6,7}. In 1992 Swedish researchers reported on finding a somewhat stronger association for childhood leukemia among children living in close proximity to transmission lines in Sweden⁸. Starting with the assertion of biological effects from electric fields and redoubled with emergence of the magnetic field effect hypothesis, laboratory scientists have reported a variety of electric and magnetic field effects found by *in vitro* (tissue culture preparations) and *in vivo* (whole animal studies) experiments.

Many of the laboratory studies and a concurrent body of clinical studies have reported effects which appear to result from exposure to fields with a wide range of magnitudes and frequencies⁹. To explain these observations, hypotheses such as "cyclotron resonance" which links the co-existence of static and ac fields have been offered. Because much of the controversy has been focused on determining if transmission lines can be cited, most of the laboratory effort has been directed at the very selective power frequencies, 50 and 60 Hz. Yet many reported results have little to do with the power frequencies. Studies report findings in the few hertz to tens of hertz frequency band. There are reports of findings when the exposure repetition rate was above the power frequencies. Some studies suggest the duration of exposure is important. Some studies suggest that both intensity (magnitude) and frequency windows exist, i.e., above or below a certain region no effect is observed. A few studies suggest that the transition from one field level to another is important, others debate whether magnetic fields act directly on the body or via induced currents. Few of these studies have been replicated and no accepted mechanism of interaction of environmentally relevant electric or magnetic field exists.

In the absence of an accepted mechanism, many have chosen to relegate the reported effect of electric and magnetic fields to the category of "pathological science" (a term coined by the late Irving Langmuir). However, the persistence of public concern necessitates that any serious attempt at magnetic field quantification which claims to serve as a basis for evaluating possible health effects must not be an inadvertently selective measure of magnitude at a single or narrow band of frequencies. In the extreme, if health effects are found, the continuum of electromagnetic exposure may be required to establish relative risk. Practically, it has only recently become possible to record and store all of the discrete segments of frequency bands which biological reports suggest may be important. Based on the biological studies reported to 1992, the electrified railroad measurements focused on the 0 to 2500 Hz portion of the electromagnetic spectrum.

2.3 THE FRENCH TGV-A TRAIN AND RAIL SYSTEM

This study concentrates on the characteristics of the French Atlantic TGV System (*Train à Grande Vitesse-Atlantique* or TGV-A) electrified railroad, which holds the world's speed record of 515.3 km/h (320 mph). The Atlantic TGV-A System line, in operation since 1989, uses somewhat newer technology than the Paris Southeast TGV-A System line. The train is in regular service from Paris to the Atlantic Coast of France, as part of the French National Railroad (SNCF). The train consists of an articulated core of ten coaches, bracketed by two locomotives at either end; one push and one pull locomotive. Multiple train sets can be coupled together.

The majority of the tests reported herein were conducted in a train consisting of two train sets coupled together. The tests in the coach portion of the train were conducted with the train out of revenue service, i.e., no passenger load. However, a two-train set required considerably more power than a fully-loaded, simple train. In fact, as the data will show, passenger loading did not appear to have a significant impact on magnetic fields. Therefore, the fields measured during this test series were representative of in-service conditions.

The double train set can be seen in the background of the photograph in Figure 2-1. The train can be powered by either power supply available to the rail network, namely 1500 volts dc or 25 kV, 50 Hz ac. The dc power is in cities such as Paris and Tours. The ac supply is throughout most of the rest of the rail line. The train is propelled via synchronous motors supplied by a variable frequency thyristor supply. There is also auxiliary 380 v, 50 Hz, three phase power for the "hotel" motors and 72 volts dc power for the lights.

The ac power supply network is comprised of a series of substations that convert incoming power transmission line voltages (typically 200 kV) into the 50 kV voltage that is applied between the catenary and the feeder line. This 50 kV supply is then transformed via a series of autotransformers into the 25 kV supply, from catenary to the rail neutral. The autotransformer stations are on the average about 9.4 km apart, from a minimum of 3.3 km to a maximum of 15.8 km. This method of supplying power to the railroad catenary system is sometimes called a 2 x 25 kV system because the feed to the 50 kV autotransformer primaries is by a balanced circuit in which the two conductors each 25 kV above ground but opposite in electrical phase. This system also has some advantages in reducing magnetic fields from current in the railroad electrification system¹⁰.



FIGURE 2-1. MEASUREMENTS BEING TAKEN ON A TGV-A STATION PLATFORM WITH THE WAVEFORM CAPTURE SYSTEM

2.4 APPROACH TO ORGANIZING ELECTROMAGNETIC DATA

The magnetic field environment over the desired frequency range from 0 to 3000 Hz can be efficiently recorded with excellent resolution using the waveform capture system described in the following subsection. Unlike most systems, which merely report the total magnetic field over their frequency range, the repetitive field waveform recording system was operated during these tests in a manner which detected and recorded the magnetic field in very narrow frequency bands, from 0 to 3000 Hz. Since magnetic field data measured earlier on other guided ground transportation systems were reported in detail over the frequency range from 0-2562 Hz, a similar range of field frequencies is employed for data reporting herein. The effective frequency resolution in the TGV-A data contained in this report and its appendices is 1 Hz increments from 0 to 64.5 Hz and 5 Hz increments up to 2562.5 Hz. Examination of the data revealed no significant magnetic field components in the frequency range from 2562.5 Hz to 3 kHz. All magnetic fields having frequency less than 0.5 Hz are classified as static fields in this report even though they may change in value over longer time scales of tens of seconds or minutes.

The data collected in this manner brackets most of the frequency bandwidth implicated by the biological findings discussed briefly above. Both temporal and spatial quantification in and around the electrified railroad are available. Because each of these measurements was repeated every few seconds to gain a measure of the long term temporal characteristics of the magnetic fields, a large as well as comprehensive dataset exists. The challenge of this report has been to reduce this data without losing the uniqueness of the information. Also to maximize the utility of the data, it must be presented so that it can be compared to data collected on the magnetic field characteristics of other electro-technologies.

To this end, the following aggregation was chosen for this evaluation. It was observed in previous Maglev and Northeast Rail Corridor electric and magnetic field studies^{1,2,3}, and is also being followed in an ongoing project to establish a rigorous protocol for quantifying the magnetic fields associated with appliances. Shown in pictorial form in Figure 2-2, this system allows for the grouping of data into frequency bands where effects have been reported and/or other datasets have been collected. The two large boxes depict the frequency regions defined by IEEE Std 100-1988¹¹ as Ultra Low Frequency (ULF), which covers the frequency range from 3 Hz down to static, and Extreme Low Frequency (ELF), which covers the frequency band from 3 Hz to 3000 Hz. Other organizations and agencies sometimes define these bands differently, but the IEEE definitions will be used throughout this report. The boxes within the large boxes depict the partitioning which was chosen to present clearly but succinctly the findings of the TGV-A electrified railroad measurements. Although the frequency groupings of the measurement data indicated as the smaller boxes do not correspond exactly with the ELF and ULF band limits indicated as the larger boxes, the aggregation illustrated in Figure 2-2 effectively divides the field measurement data into bands consistent with the definitions of the ULF and ELF frequency bands.

The partitioning in Figure 2-2 also allows for comparison with data collected by less sophisticated instruments. In particular, the EMDEX-II widely used in the utility industry has a 3 dB bandwidth between 40 Hz and 800 Hz. Other survey meters only respond to the power frequency band.

2.5 INSTRUMENTATION

The principal instrumentation system used for magnetic field measurements on the electrified railroads was a portable version of the waveform capture system recorder. The waveform capture system was augmented with a digital audio tape (DAT) recorder to obtain a continuous record of magnetic field levels at one location. RMS

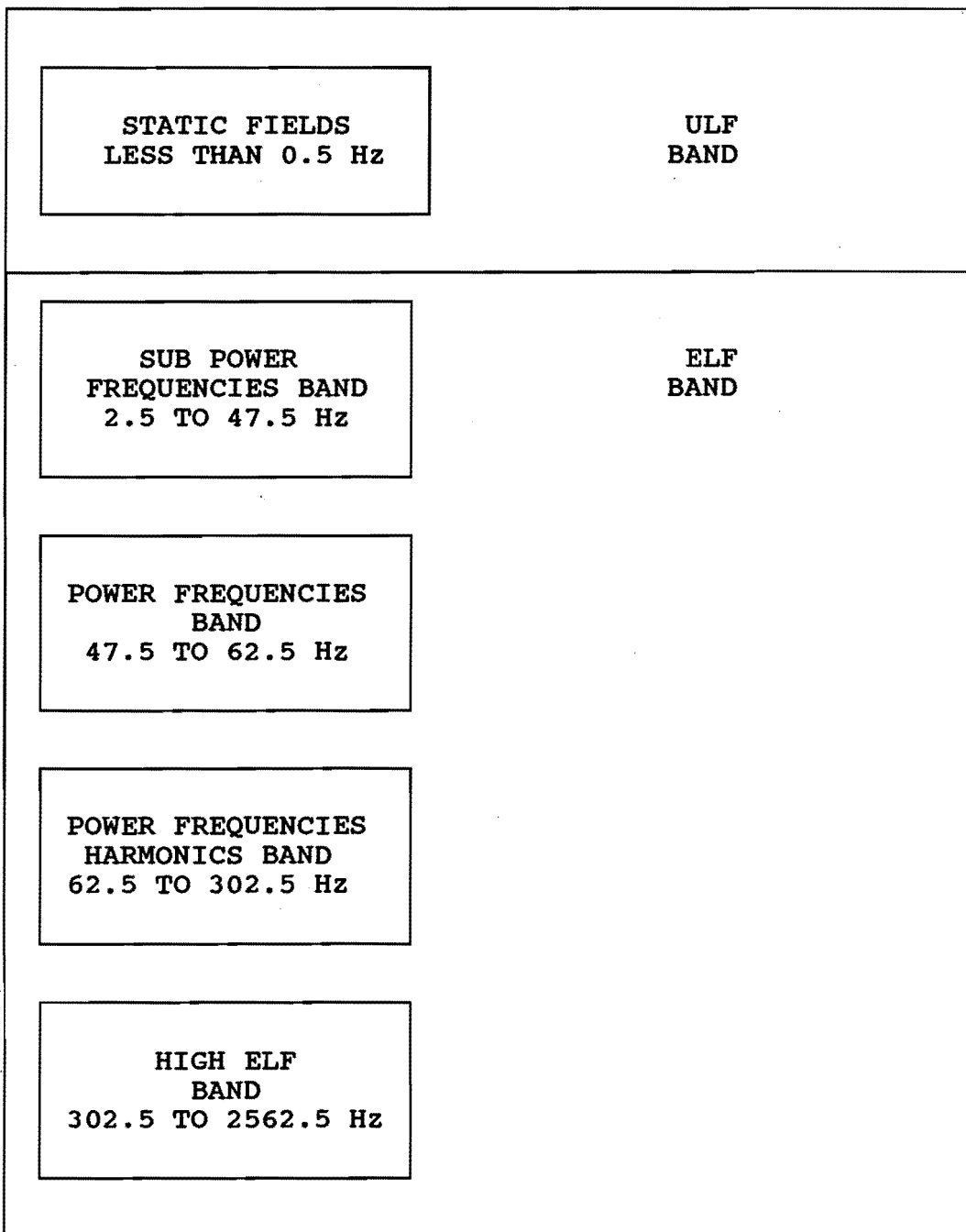

FIGURE 2-2. MAGNETIC FIELD FLUX DENSITIES GROUPED BY FREQUENCY PARTITIONS WITHIN THE ELF BAND AND ULF BAND

personal exposure monitors were also used to document the significance of personal movement throughout the train and associated facilities. Additionally, an electric field meter was used for some of the tests.

2.5.1 Portable Waveform Capture System

The portable repetitive field waveform recording system used in the electrified railroad tests is a version of the waveform capture system recorder used for the Transrapid TR07 measurements, as optimized for measurements on transportation systems. The magnetic field waveform recording approach utilized by the waveform capture system has already been reported¹. The portable version configured for transportation system measurements employs the same measurement philosophy and uses software nearly identical to the standard waveform capture system software in the following ways:

- A high performance 386-based notebook computer replaces the larger portable computer
- A battery-powered system box has been developed to house the input signal programmable amplifiers, the analog-to-digital conversion circuitry, and the bus interface to the computer.
- 32 input channels (10 3-axis signals and 2 single-axis signals) can be monitored simultaneously
- Fluxgate magnetometers with improved range (0-6 gauss) and improved frequency response (0-3 kHz) are used as input sensors
- Miniaturized coil type sensors with overall system frequency response (5 Hz - 3 kHz) used as input if the total field exceeds 5 gauss
- Anti-aliasing filters included in the design
- Increased sampling rate
- Interface provided to a DAT recorder
- Four sensors incorporated into a measurement staff.

The functional significance of these changes is as follows:

- The system is now truly portable
- ac power is not required for operation
- ac and dc magnetic fields are measured simultaneously at the same locations
- Measurement staff ensures the rapid and accurate placement of four sensors for field profile measurements.

The portable waveform capture system was operated throughout the TGV-A System tests in modes which produce data directly comparable to the data obtained on the Transrapid TR07 Maglev and the NEC^{1,2,3}. Hence the results reported for the TR07 and the NEC system can be compared directly to the results reported herein for the TGV-A electrified railroad.

2.5.2 Digital Audio Tape Recorder

The repetitive field waveform recording system is a sampling-type recording system in the sense that it records the magnetic field environment in great detail for a brief period of time (0.2 to 1.0 seconds) then pauses for a period of time (5 to 60 seconds) before initiating another detailed sample. Hence, there is a possibility that the repetitive field waveform system could miss capturing brief events such as rapid field transients if they are very rare. Since transients are defined as any non-periodic change in the field, transients can and do span time periods from nanoseconds to tens of seconds. In order to determine whether the sampling recording system was failing to capture rare short-term events (longer than 50 microseconds and shorter than 5 seconds), a Teac Model RD 130T digital audio tape recorder (DAT) was connected to the analog output port of the waveform capture system's reference probe. This permitted the DAT to make continuous recordings of the three-axis field (0-2500 Hz, 6 gauss full scale) at the reference probe. Three additional channels of the DAT made continuous recordings of the ac field (3-2500 Hz) amplified by a factor of ten or more to ensure enough resolution for accurate recording of the higher frequency components.

2.5.3 EMDEX-II Recorders

The Electric and Magnetic Digital Exposure (EMDEX) (hereinafter referred to as "rms") meters developed for the Electric Power Research Institute (EPRI) are convenient and useful instruments for monitoring personal exposure to magnetic fields from power systems. Their broadband response is nominally 40 to 800 Hz, which is adequate to capture the fundamental and low order harmonic components of the magnetic fields from 50 Hz or 60 Hz power systems. Unfortunately the pass band of the rms meter is not sufficient to capture the low frequency time varying fields encountered in the TGV-A System coaches or in the cab while operating accurately on the dc catenary. Nevertheless, the rms recorders have been used throughout the measurement programs as personal exposure monitors to determine the extent to which stationary field measurements correlate with exposure of a passenger moving throughout the train.

2.6 REPETITIVE WAVEFORM DATA

As described in the preceding reports^{2,11}, the repetitive field waveform recording system records the actual waveform of the three orthogonal components of the magnetic field at multiple measurement locations by sampling those waveforms at a high rate and storing the values digitally on computer disk or computer tape. These digital waveform recordings are saved one after another in rapid succession. Any one of these waveform recordings can be viewed individually in either the time or frequency domain to get a

"snapshot view" of the waveform or frequency spectrum of the magnetic field at the particular instant in time when the waveform sample was recorded. These "snapshots" when viewed individually have little statistical validity and tell nothing about the evolution of magnetic field characteristics over time as the train speeds up, slows down, makes use of its dynamic braking, passes the station, and so on. In order to examine these questions of statistical and temporal variability of the magnetic field, many of these "snapshots" must be played back in rapid succession to produce a "moving picture" of the magnetic field at each measurement location.

As described in later sections of the report, the measurement protocol applied for the electrified railroad measurements generally involved the use of five fluxgate magnetic field (B) sensors arrayed in such a way that spatial variability of the magnetic field could be characterized. Since magnetic fields onboard or near the train can arise from numerous sources, each with different temporal characteristics, the spatial pattern of the magnetic field is a dynamic characteristic which must be assessed from the "moving picture" of the magnetic field obtained from analysis of the repetitive waveform samples.

A list of the repetitive waveform datasets collected during the measurements on the TGV-A electrified railroad is given in Table 2-1. The table also identifies the nature of the measurement, the measurement time, and the sample time for each of the 34 datasets.

Table 2-1 also gives numerical code sensor locations which are described in more detail later in the report. The analysis method applied to these repetitive waveform datasets is described in detail in a previous report². The information contained in each of the 34 datasets has been processed using the procedure described in the following subsection and is presented in detail in Appendices B through AI in Volume II of this report.

2.7 DAT WAVEFORM DATA

Three-axis magnetic field waveforms from the waveform capture system reference sensor were recorded using the digital audio tape recorder. Two recordings were made of each orthogonal component (axis) of the field: one of the signal directly from the magnetometer; and a second of the signal with the static component filtered out and the time varying components amplified (usually by a factor of ten) to provide better resolution of higher frequency components. Approximately six hours of recordings were produced for the test conditions reported in Table 2-2.

The continuous recordings of magnetic field waveform were reviewed for transient magnetic field conditions which might exist as the train crosses catenary phase breaks or passes from the dc to 50 Hz

section of the line. Rapidly changing magnetic field conditions such as those at a station platform were also examined.

The final type of analysis conducted on the DAT data was to conduct plots of rms ac magnetic field and total static field over the time of the recordings. These results were compared to the corresponding data from the portable waveform capture system to determine whether the data sampling procedure of the waveform capture system lost any significant data which is obtainable by continuous monitoring.

2.8 RMS RECORDER DATA

Several rms recordings were made by members of the measurement crew while traveling on the electrified railroad or working at the stations, wayside, or power supply facilities. These data are compared and contrasted with the waveform capture system and DAT data.

TABLE 2-1.

INDEX OF REPETITIVE WAVEFORM DATA FRENCH TGV-A
SEPTEMBER 8-SEPTEMBER 9, 1992

DATA FILE NUMBER	APPENDIX CONTAINING DATA	DATE/TIME	PROBE LOCATION FIG. STAFF REF.			SAMPLE INTERVAL, SECONDS	NUMBER OF SAMPLES	LOCATION AND TYPE OF MEASUREMENT
		SEP 08						
TGV001	B	07:57-08:17	3-2	1	4	10	101	TGV-A TEST TRAIN, DOUBLE TRAIN SET, IN 1ST COACH, (R1B, FIGURE 3-1). FOUR SENSOR STAFF AT FRONT OF COACH IN 1ST CLASS SALON. STAFF IN VERTICAL POSITION. FLOOR OF COACH AS REFERENCE.
TGV002	C	08:18-08:22	3-2	1	4	30	09	SAME
TGV003	D	08:23-08:27	3-2	2	4	30	10	SAME EXCEPT STAFF IS IN A HORIZONTAL POSITION ALONG THE AXIS OF THE TRAIN 1 m (3.3 ft) ABOVE THE FLOOR. DOOR ABOVE MIDDLE SEAT IS REFERENCE.
TGV004	E	08:28-08:33	3-2	3	4	30	10	SAME EXCEPT STAFF IS IN A HORIZONTAL POSITION TRANSVERSE TO THE AXIS OF THE TRAIN 1 m (3.3 ft) ABOVE THE FLOOR. WINDOW ABOVE SIDE SEAT IS REFERENCE.

TABLE 2-1.

INDEX OF REPETITIVE WAVEFORM DATA FRENCH TGV-A
SEPTEMBER 8-SEPTEMBER 9, 1992 (CONT'D)

DATA FILE NUMBER	APPENDIX CONTAINING DATA	DATE/TIME	PROBE LOCATION			SAMPLE INTERVAL, SECONDS	NUMBER OF SAMPLES	LOCATION AND TYPE OF MEASUREMENT
			FIG.	STAFF	REF.			
TGV005	F	09:15-09:29	4-1	5	8	10	75	TGV-A TEST TRAIN, DOUBLE TRAIN SET, IN PULL LOCOMOTIVE TGV24081 (TU1B, FIGURE 3-1). FOUR SENSOR STAFF AT DRIVERS RIGHT SHOULDER IN THE LOCOMOTIVE CAB. STAFF IN VERTICAL POSITION. FLOOR OF CAB AS REFERENCE.
TGV006	G	09:30-09:42	4-1	5	8	30	25	SAME
TGV007	H	09:43-09:48	4-1	6	8	30	10	SAME EXCEPT STAFF IS IN A HORIZONTAL POSITION TRANSVERSE TO THE AXIS OF THE TRAIN 1 m (3.3 ft) ABOVE THE FLOOR. SIDE WALL OF CAB IS REFERENCE.
TGV008	I	09:49-09:53	4-1	7	8	30	10	SAME EXCEPT STAFF IS IN A HORIZONTAL POSITION ALONG THE AXIS OF THE TRAIN 1.3 m (4.3 ft) ABOVE THE FLOOR. BACK WALL OF CAB IS THE REFERENCE.
TGV009	J	09:56-10:14	4-1	5	8	30	38	STAFF IN SAME POSITION AS FOR DATASET TGV005
TGV010	K	10:50-10:51	8-1	10	12	10	10	IN THE TGV-A CONTROL CENTER ON 6TH FLOOR IN FRONT OF COMPUTER MONITORS. USING 4 SENSOR STAFF IN THE VERTICAL POSITION. FLOOR OF CONTROL CENTER IS THE REFERENCE.

TABLE 2-1.

INDEX OF REPETITIVE WAVEFORM DATA FRENCH TGV-A
SEPTEMBER 8-SEPTEMBER 9, 1992 (CONT'D)

DATA FILE NUMBER	APPENDIX CONTAINING DATA	DATE/TIME	PROBE LOCATION			SAMPLE INTERVAL, SECONDS	NUMBER OF SAMPLES	LOCATION AND TYPE OF MEASUREMENT
			FIG.	STAFF	REF.			
TGV011	L	10:52-10:54	8-1	11	12	10	10	SAME EXCEPT STAFF IS IN THE HORIZONTAL DIRECTION .9 m (3 ft) ABOVE THE FLOOR. CENTER OF A MONITOR SCREEN IS THE REFERENCE.
TGV012	M	14:03-14:20	3-3	13	16	10	95	TGV-A TEST TRAIN, DOUBLE TRAIN SET, IN 2ND COACH (R2B, FIGURE 3-1). FOUR SENSOR STAFF IN CENTER OF A 1ST CLASS CLUB CAR. STAFF IN VERTICAL DIRECTION. FLOOR OF COACH AS REFERENCE.
TGV013	N	14:21-14:26	3-3	14	16	30	10	SAME EXCEPT STAFF IS IN A HORIZONTAL POSITION TRANSVERSE TO THE AXIS OF THE TRAIN 1 m (3.3 ft) ABOVE THE FLOOR. SIDE WALL ABOVE SEATS 42 & 43 IS THE REFERENCE.
TGV014	O	14:28-14:32	3-3	15	16	30	10	SAME EXCEPT STAFF IS IN A HORIZONTAL POSITION ALONG THE AXIS OF THE TRAIN 1 m (3.3 ft) ABOVE THE FLOOR. MIDLINE BETWEEN SEATS 41 & 42 IS THE REFERENCE.
TGV015	P	15:09-15:11	8-2	17	-	10	12	IN VENDOME RELAY ROOM. FOUR SENSOR STAFF NEAR AC POWER CABINET. STAFF IN VERTICAL POSITION. FLOOR OF RELAY ROOM IS REFERENCE.

TABLE 2-1.

INDEX OF REPETITIVE WAVEFORM DATA FRENCH TGV-A
 SEPTEMBER 8-SEPTEMBER 9, 1992 (CONT'D)

DATA FILE NUMBER	APPENDIX CONTAINING DATA	DATE/TIME	PROBE LOCATION			SAMPLE INTERVAL, SECONDS	NUMBER OF SAMPLES	LOCATION AND TYPE OF MEASUREMENT
			FIG.	STAFF	REF.			
TGV016	Q	15:15-15:17	8-2	18	-	10	12	IN VENDOME RELAY ROOM. FOUR SENSOR STAFF BETWEEN TWO ROWS OF RELAYS. STAFF IN VERTICAL POSITION. FLOOR OF RELAY ROOM IS REFERENCE.
TGV017	R	16:03-16:05	6-1	19	20	5	13	ON TGV-A PLATFORM AT VENDOME. HIGH SPEED TRAIN TO TOURS ON FAR TRACK. SINGLE TRAIN SET. FOUR SENSOR STAFF. STAFF IN VERTICAL POSITION. TO PARIS PLATFORM FLOOR AS REFERENCE.
TGV018	S	16:34-16:45	6-1	19	20	5	73	SAME EXCEPT A DIFFERENT TRAIN PASSED HEADING TO TOURS.
TGV019	T	16:50-16:54	6-1	19	20	5	25	SAME EXCEPT HIGH SPEED TRAIN TO PARIS ON THE NEAR TRACK. DOUBLE TRAIN SET.
TGV020	U	17:14-17:16	3-4	21	24	5	22	TGV-A TEST TRAIN, DOUBLE TRAIN SET, IN 5TH COACH (R5B, FIGURE 3-1). FOUR SENSOR STAFF IN CENTER OF 2ND CLASS CAR. STAFF IN VERTICAL POSITION. FLOOR OF COACH NEAR CORNER OF SEAT 47 IS THE REFERENCE.
TGV021	V	17:17-17:27	3-4	21	24	5	63	SAME

2-16

TABLE 2-1.

INDEX OF REPETITIVE WAVEFORM DATA FRENCH TGV-A
 SEPTEMBER 8-SEPTEMBER 9, 1992 (CONT'D)

DATA FILE NUMBER	APPENDIX CONTAINING DATA	DATE/TIME	PROBE LOCATION			SAMPLE INTERVAL, SECONDS	NUMBER OF SAMPLES	LOCATION AND TYPE OF MEASUREMENT
			FIG.	STAFF	REF.			
TGV022	W	17:28-17:32	3-4	22	24	30	10	SAME EXCEPT STAFF IS IN A HORIZONTAL POSITION TRANSVERSE TO THE AXIS OF THE TRAIN 1 m (3.3 ft) ABOVE THE FLOOR. SIDE WINDOW ACROSS FROM SEATS 41 & 42 IS THE REFERENCE.
TGV023	X	17:33-17:38	3-4	23	24	30	10	SAME EXCEPT STAFF IS IN A HORIZONTAL POSITION ALONG THE AXIS OF THE TRAIN 1 m (3.3 ft) ABOVE THE FLOOR. CORNER OF SEAT 46 IS THE REFERENCE.
TGV024	Y	17:38-17:54	3-4	21	24	30	32	STAFF IN SAME POSITION AS FOR DATASET TGV020
		SEP 09						
TGV025	Z	07:45-08:01	4-2	25	26	10	88	TGV-A REVENUE TRAIN, SINGLE TRAIN SET, IN PULL LOCOMOTIVE TGV24006 (TU2, FIGURE 3-1). FOUR SENSOR STAFF AT DRIVER'S RIGHT SHOULDER IN THE LOCOMOTIVE CAB. STAFF IN VERTICAL DIRECTION. FLOOR OF CAB IS STAFF REFERENCE.
TGV026	AA	08:01-08:21	4-2	25	26	30	40	SAME

TABLE 2-1.

INDEX OF REPETITIVE WAVEFORM DATA FRENCH TGV-A
 SEPTEMBER 8-SEPTEMBER 9, 1992 (CONT'D)

DATA FILE NUMBER	APPENDIX CONTAINING DATA	DATE/ TIME	PROBE LOCATION			SAMPLE INTERVAL, SECONDS	NUMBER OF SAMPLES	LOCATION AND TYPE OF MEASUREMENT
			FIG.	STAFF	REF.			
TGV027	AB	10:16- 10:18	7-2	27	28	10	12	TGV-A AUTOTRANSFORMER AT CHAILLOT. MEASUREMENTS OUTSIDE BACK FENCE OF AUTOTRANSFORMER ALONG TGV-A LINE AT CHAILLOT NEAR THE 121 km MARKER. STAFF IN VERTICAL POSITION. GROUND IS STAFF REFERENCE.
TGV028	AC	10:26- 10:34	7-2	27	28	10	36	SAME
TGV029	AD	10:58- 11:03	5-1	29	30	5	33	OVERPASS NEAR THE 120 km MARKER CLOSE TO CHAILLOT. MEASUREMENTS OVER THE CATENARY 1 m (3.3 ft) FROM THE STEEL GUARD RAIL. MEASUREMENTS TAKEN AS HIGH SPEED (DOUBLE TRAIN SET) TRAIN TO PARIS PASSED UNDER THE OVERPASS. STAFF IN VERTICAL POSITION. GROUND IS STAFF REFERENCE.
TGV030	AE	13:24- 13:29	5-2	31	32	10	23	UNDERPASS NEAR THE 105 km MARKER CLOSE TO BONNEVAL. MEASUREMENTS TAKEN AS HIGH SPEED TRAIN TO PARIS PASSED OVER THE UNDERPASS. STAFF IN VERTICAL POSITION. GROUND IS STAFF REFERENCE.

TABLE 2-1.

INDEX OF REPETITIVE WAVEFORM DATA FRENCH TGV-A
SEPTEMBER 8-SEPTEMBER 9, 1992 (CONT'D)

DATA FILE NUMBER	APPENDIX CONTAINING DATA	DATE/ TIME	PROBE LOCATION			SAMPLE INTERVAL, SECONDS	NUMBER OF SAMPLES	LOCATION AND TYPE OF MEASUREMENT
			FIG.	STAFF	REF.			
TGV031	AF	14:15- 14:32	5-3	33	34	10	83	OPEN SPACE NEAR TRACK AT THE 104 km MARKER. MEASUREMENT STAFF 7.5 m (24.6 ft) FROM THE NEAR TRACK (TO PARIS). MEASUREMENTS TAKEN FOR DOUBLE TRAIN SET TO TOURS, SINGLE TRAIN SET TO TOURS, AND SINGLE TRAIN SET TO PARIS. STAFF IN THE VERTICAL POSITION. GROUND IS STAFF REFERENCE.
TGV032	AG	15:18- 15:22	7-1	35	36	10	25	GAULT ST. DENIS SUBSTATION AT THE 94.75 km MARKER. MEASUREMENTS TAKEN 2 m (6.6 ft) OUTSIDE OF FENCE AT THE BACK OF THE SUBSTATION. DURING MEASUREMENT SEQUENCE SINGLE TRAIN SET TO PARIS PASSED. STAFF IN THE VERTICAL POSITION. GROUND IS STAFF REFERENCE.
TGV033	AH	15:25- 15:28	7-1	35	36	10	19	SAME
TGV034	AI	15:43- 15:56	7-1	37	38	10	68	SAME EXCEPT MEASUREMENT WAS TAKEN IN SIDE OF THE SUBSTATION CONTROL HOUSE. MEASUREMENT TAKEN WHILE SINGLE TRAIN SET TO TOURS AND A SINGLE TRAIN SET TO PARIS PASSED BY. STAFF IN THE VERTICAL DIRECTION. CONTROL HOUSE FLOOR IS STAFF REFERENCE.

TABLE 2-2.

**INDEX OF CONTINUOUS WAVEFORM (DAT) DATA FRENCH TGV-A MEASUREMENTS
SEPTEMBER 8-9, 1992**

TAPE/ RECORD #	DATE/TIME	PROBE LOCATION		RECORD LENGTH MIN:SEC	LOCATION AND TYPE OF MEASUREMENT
		FIGURE	LOCATION		
	SEP 08				
5/1	7:57:22	3-2	4	64:49	PASSENGER SEAT IN THE FIRST CLASS SALON DURING A TRIP FROM PARIS TO ST PIERRE-DES-CORPS
5/2	9:14:24	4-1	8	57:14	ON CONSOLE IN FRONT OF THE ASST ENGINEER'S SEAT IN THE CAB DURING A TRIP FROM ST PIERRE-DES-CORPS TO PARIS
2/1	10:41:29	8-1	12	4:22	DISPATCHER'S SEAT IN THE MONTPARNASSE STATION CONTROL ROOM
2/2	14:03:28	3-2	16	41:05	PASSENGER SEAT IN A FIRST CLASS COACH (R2 OF FIGURE 3-1) DURING A TRIP FROM PARIS TO VENDOME
2/3	15:57:34	6-1	20	35:21	STATION PLATFORM AT VENDOME (PAUSE IN RECORDING FROM 16:09:50 TO 16:27:11)
3/1	17:12:21	3-2	24	42:16	PASSENGER SEAT IN A SECOND CLASS COACH (R5 OF FIGURE 3-1) DURING A TRIP FROM VENDOME TO PARIS

TABLE 2-2.

INDEX OF CONTINUOUS WAVEFORM (DAT) DATA FRENCH TGV-A MEASUREMENTS
SEPTEMBER 8-9, 1992 (CONT'D)

TAPE/ RECORD #	DATE/TIME	PROBE LOCATION		RECORD LENGTH MIN:SEC	LOCATION AND TYPE OF MEASUREMENT
		FIGURE	LOCATION		
	SEP 09				
3/2	7:51:57	4-1	26	42:16	ON CONSOLE IN FRONT OF THE ASST ENGINEER'S SEAT IN THE CAB OF A REVENUE SERVICE TRAIN DURING A TRIP FROM PARIS TO VENDOME
3/3	10:15:33	7-2	28	18:26	15 m (49 ft) OUTSIDE AN AUTO-TRANSFORMER STATION
3/4	10:57:01	5-1	30	6:23	ON THE SIDEWALK OF AN OVERPASS ABOVE THE CATENARY
3/5	13:24:56	5-2	32	4:14	10 cm (.3 ft) ABOVE GROUND BENEATH THE TRACKS AT AN UNDERPASS
3/6	14:14:09	5-3	34	18:12	22.5 m (74 ft) FROM THE TRACKS AT AN OPEN WAYSIDE AREA
4/1	15:18:18	7-1	36	10:47	15 m (49 ft) OUTSIDE THE SUBSTATION
4/2	15:42:55	7-1	38	12:42	10 cm (.3 ft) ABOVE GROUND INSIDE THE SUBSTATION BENEATH THE LOW VOLTAGE BUS

2-21/2-22

3. ONBOARD COACH MEASUREMENTS

When developing the measurement plan for these tests, it was apparent that magnetic fields within the coach could arise from various sources:

- Catenary and track power circuit;
- Equipment in the locomotive (Power Car);
- Rectifiers and inverters under the coaches;
- Hotel power above the coaches;
- Heating, lighting, air conditioning and other equipment on the coaches; and
- External sources, such as other trains and nearby transmission lines.

It should also be noted that the major portion of the line is fed by a catenary system supplied by 25 kV, 50 Hz power, except in cities such as Paris and Tours. In these cities, the train is powered by a catenary system supplied by 1500 volts dc. In order to best evaluate the significance of the above-mentioned sources and power supply arrangements, field measurements were made at three locations inside the double train set made available for these tests. Figure 3-1 depicts the TGV-A System train layout and the measurement locations. The test train, running empty of passengers but with normal speed profiles, made four trips on September 8, 1992. The three measurement locations in the coach section of the train were:

- 1) Front of first coach - This point nearest the locomotive maximizes the chance of detecting fields from equipment in the locomotive.
- 2) Middle of second coach - This is a coach with no major equipment onboard. Measurements here maximize the chance of detecting fields from hotel power cables above in the ceiling of the coach because it is somewhat removed from possible effects from the locomotive, yet is near cables which provide power to the other coaches.
- 3) Middle of fifth coach - This is approximately the midpoint of the train. There is also a three phase inverter for "hotel" power under the car.

Each train set is comprised of ten coach cars and two locomotives, one push and one pull. Coaches are numbered R1 to R10, with R1 being the coach nearest the direction to Paris, regardless of the direction of the train. In other words, the train reverses simply by having the push locomotive become the pull locomotive, and vice versa. The train does not turn around. Thus, Coach R1 is the last coach on the trip to Tours and the first coach on the trip to Paris. As the name implies, a double train set consists of two single sets, that is, a total of four locomotives and 20 coach cars.

TGV Train and Measurement Layout

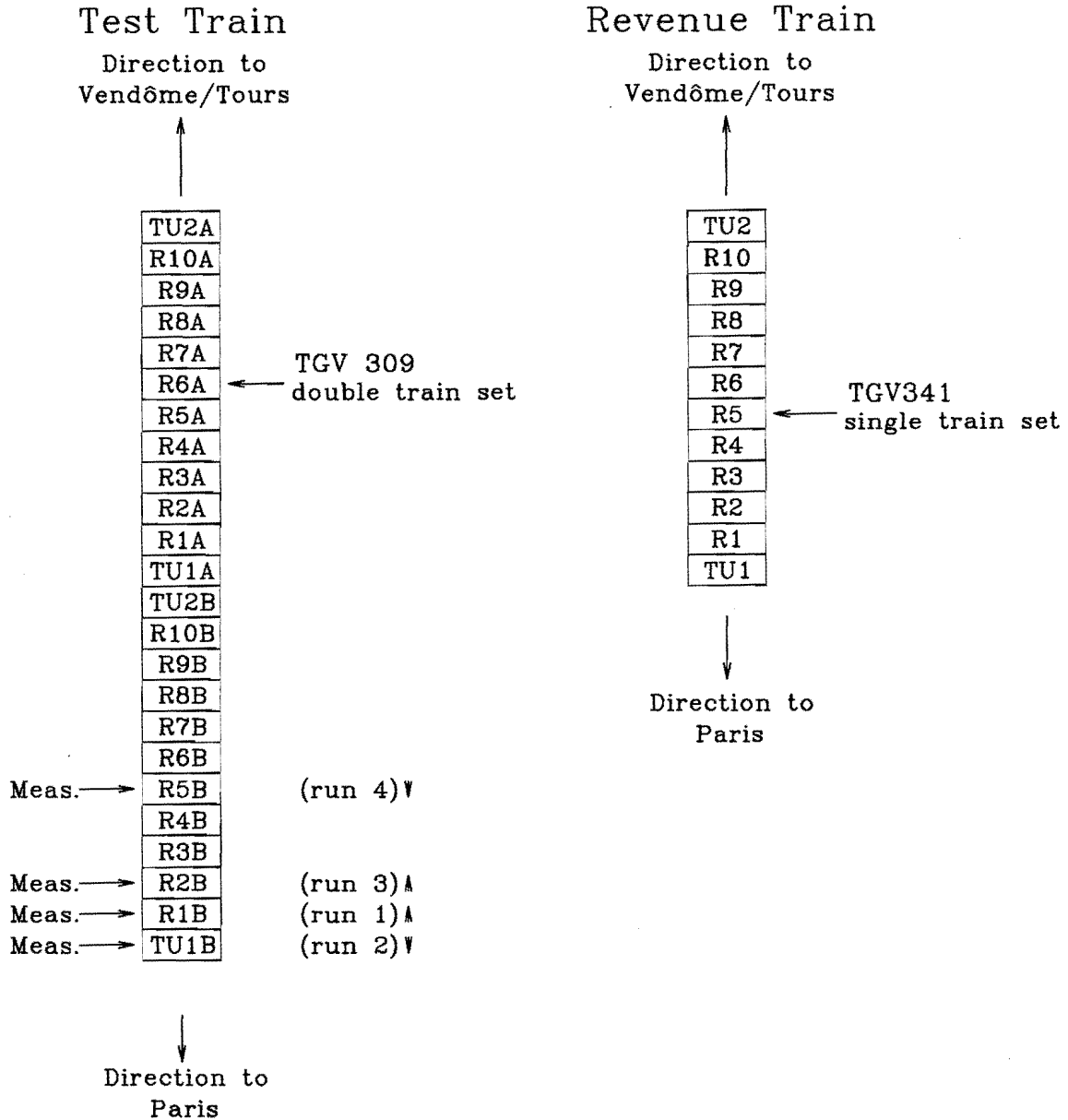

FIGURE 3-1. TRAIN LAYOUT AND REPETITIVE WAVEFORM MEASUREMENT LOCATIONS FOR BOTH THE DOUBLE TEST TRAIN (FIRST DAY) AND THE SINGLE REVENUE TRAIN (SECOND DAY)

The trips for the day were as follows:

Trip 1	Paris to Tours, 1st Class salon, 1st coach
Trip 2	Tours to Paris, Cab
Trip 3	Paris to Vendome, 1st Class, 2nd coach
Trip 4	Vendome to Paris, 2nd Class, 5th coach

3.1 MEASUREMENT LOCATIONS

The numbered measurement locations are keyed to datasets in Tables 2-1 and 3-1 and to the data in the corresponding appendices. The numbered locations are also shown in the corresponding figures.

Figure 3-2 depicts the layout of all three TGV-A System coaches. The upper part shows coach R1B. This coach was selected as the coach that is closest to the locomotive. Measurements were made in the 1st Class salon at three different positions. Datasets TGV001 and TGV002 were made with the staff in a vertical position. Dataset TGV003 was made with the staff in a horizontal position, in the direction of travel. Dataset TGV004 was made with the staff in a horizontal position above a side seat, in the transverse orientation, from the window towards the center of the train. The reference probe was always on the corner seat. Both horizontal profiles were measured at a height of approximately 1 m (3.3 ft) above the floor. These datasets were taken aboard the test train on September 8, 1992 from 07:57 to 08:33.

Figure 3-2 also depicts coach R2B and the specific locations where measurements were taken on the 3rd trip from Paris to Vendome. The measurement locations were onboard the 2nd coach, in the middle of the car. Dataset TGV012 was taken with the staff in a vertical position, #13 in the figure. Dataset TGV013 was taken with the staff in a horizontal position transverse to the train, from the wall toward the center of the car, above seats 42 and 43. It is 1 m (3.3 ft) above the floor and is marked #14 in the figure. Dataset TGV014 was taken with the staff in a horizontal position, 1 m (3.3 ft) above the floor, in the axial direction of the train. It is marked as position #15 in the figure. The reference probe was always located by the aisle on seat 42 and is marked #16 in the figure. All measurements were taken between the hours of 14:03 and 14:32 on September 8, 1992.

Figure 3-2 shows the locations of the measurements made in car number R5B during trip number 4. All five datasets were taken in the middle of the car. Datasets TGV020, TGV021 and TGV024 were taken with the staff in a vertical position between seats 46 and 47. Their position is shown as position #21 in the figure. Dataset TGV022 was taken in a horizontal position, 1 m (3.3 ft) above the floor, in a transverse direction to travel, between seats 41 and 45. It is shown as position #22. Finally, dataset TGV023 was taken with the staff in a horizontal position, 1 m (3.3 ft) above the floor, along the axis of the train. The position is

TABLE 3-1.

REPETITIVE MAGNETIC FIELD WAVEFORM
DATASETS MEASURED ONBOARD COACHES

DATASET NUMBER	DATE/ TIME	LOCATION FIG. #	# OF SAMPLES & RATE	APPENDIX	REMARKS: CAR # & STAFF POS.
TGV001	SEP. 8 07:57-08:17	1 3-2	101 10 SEC	B	CAR R1 VERTICAL
TGV002	SEP. 8 08:18-08:22	1 3-2	9 30 SEC	C	CAR R1 VERTICAL
TGV003	SEP. 8 08:23-08:27	2 3-2	10 30 SEC	D	CAR R1 AXIAL
TGV004	SEP. 8 08:28-08:33	3 3-2	10 30 SEC	E	CAR R1 TRANSVERSE
TGV012	SEP. 8 14:03-14:20	13 3-3	95 10 SEC	M	CAR R2 VERTICAL
TGV013	SEP. 8 14:21-14:26	14 3-3	10 30 SEC	N	CAR R2 TRANSVERSE
TGV014	SEP. 8 14:28-14:32	15 3-3	10 30 SEC	O	CAR R2 AXIAL
TGV020	SEP. 8 17:14-17:16	21 3-4	22 5 SEC	U	CAR R5 VERTICAL
TGV021	SEP. 8 17:17-17:27	21 3-4	63 5 SEC	V	CAR R5 VERTICAL
TGV022	SEP. 8 17:28-17:32	22 3-4	10 30 SEC	W	CAR R5 TRANSVERSE
TGV023	SEP. 8 17:33-17:38	23 3-4	10 30 SEC	X	CAR R5 AXIAL
TGV024	SEP. 8 17:38-17:54	21 3-4	32 30 SEC	Y	CAR R5 VERTICAL

marked #23 in the figure. The reference probe was located on seat 46 and is shown as position #24. These five datasets were taken aboard the test train on September 8, 1992 from 17:14 to 17:54.

3.2 REPETITIVE WAVEFORM DATASETS

Twelve repetitive waveform datasets quantifying magnetic field characteristics within the coaches were recorded with the waveform capture system. Table 3-1 is a summary of pertinent information about these datasets, obtained from Table 2-1. All of these

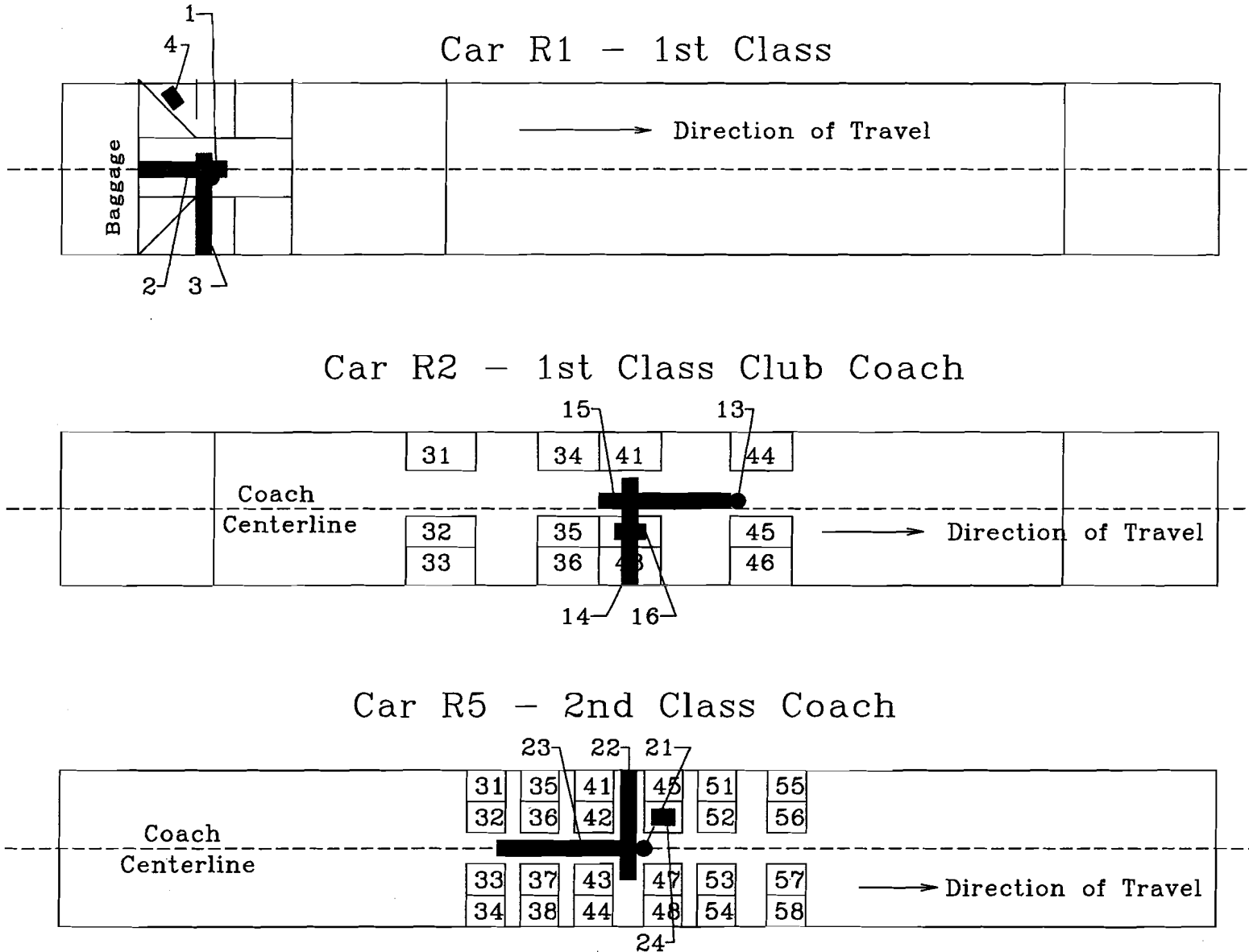

3-5

FIGURE 3-2. REPETITIVE WAVEFORM MEASUREMENT LOCATIONS IN CARS R1B-FIRST CLASS SALON, R2B-FIRST CLASS CLUB COACH AND R5B-SECOND CLASS COACH

datasets represent profile measurements, either vertical or horizontal, at distances of 10, 60, 110, and 160 cm along the staff. Complete plots of field versus frequency over time, and field versus distance over time, are found in the appendices as indicated in Tables 2-1 and 3-1. The appendices also contain notes about train operating conditions, locations and, where pertinent, the presence of external field sources such as power lines or substations.

3.3 MAGNETIC FIELD SOURCE IDENTIFICATION

Magnetic field measurements onboard the coaches provided the opportunity to measure the extent to which various operating conditions contribute to the total magnetic field environment. That is because measurements were made onboard the train while operating from both dc and ac catenaries, during the transition between the two, and also while at rest. Table 3-2 summarizes the average values of the measured field during these various operating conditions. The maximum measured values appear in Table 3-3.

It appears that the major contribution to the onboard fields comes from the dominant power supply. For example, the maximum STATIC value for the AT REST and ac cases is less than 1000 mG; the corresponding maximum value during the dc supply operation is more than three times the AT REST value. Conversely, the maximum value in the power frequency range is less than 6 mG in all cases except during operation with the ac power supply, where it is 165 mG, almost 30 times larger. These are clear indications that the major contributors are power current in the catenary, tracks, return feeder, conductor or conductors running above (for ac) and below (for dc) the coaches linking the two locomotives.

This effect can also be seen by examining one of the many figures in the appendix. An illustrative dataset is that of the 60 cm above the floor of dataset TGV001. Figure 3-3 shows pseudo-three-dimensional graphs of the magnetic field versus frequency and time in the 1st Class salon near the end of the train (Location 2 on Figure 3-1) for dataset TGV001 (Appendix B). Figure 3-3 demonstrates the following characteristics, all of which implicate the catenary-track circuit as the primary source:

- Field intensity is highly variable over time, consistent with fluctuating catenary-track current required to supply the locomotive's traction power needs;
- Field characteristics change at approximately 500 seconds into the run. This is the time of transition from dc to ac power. The high variability is exhibited first in the static field and then in the 50 Hz field (upper portion of Figure 3-3);

TABLE 3-2.

AVERAGE MAGNETIC FIELD VALUES IN MG
MEASURED ONBOARD COACHES
AT DIFFERENT OPERATING CONDITIONS

FREQUENCY BAND	TRAIN AT REST	DC SECTION	DC TO AC TRANSITION	AC SECTION
	19 SAMPLES TGV001	29 SAMPLES TGV001, 012 & 024	10 SAMPLES TGV001	252 SAMPLES TGV001, 002, 012, 020, 021 & 024
STATIC	433.76	912.77	415.17	544.97
5-45 Hz LOW FREQ	0.39	9.51	10.69	23.34
50-60 Hz PWR FREQ	0.33	1.02	0.90	30.54
65-300 Hz PWR HARM	0.70	6.02	1.51	2.70
305-2560 Hz HIGH FREQ	0.68	1.14	0.96	1.45
5-2560 Hz ALL FREQ	1.14	9.95	10.96	43.16

- Frequency components of the magnetic field are 50 Hz and its odd harmonics (150 Hz, 250 Hz, 350 Hz, 450 Hz, 550 Hz, etc.) consistent with the frequency characteristics of the catenary-track current.

Closer examination of Figure 3-3 reveals a very low magnitude and variable frequency component that starts at approximately 500 sec. into the run and ranges from 100 Hz to 200 Hz. This trace and its characteristics correlate with the researcher's log of the train speed while running in the ac sector. The log states that the train started coasting (stopped accelerating) at approximately 600 seconds into the TGV001 run, started to accelerate again at approximately 720 seconds, and later reached cruising speed at approximately 850 seconds. This variable frequency component of the magnetic field may have existed earlier (see discussion in Section 4.3), but may have been masked by the low frequency fields from other sources.

There does not seem to be any effect from external sources, either from other trains passing by or the test train passing substations, power lines or autotransformers. Several instances of such events

TABLE 3-3.

MAXIMUM MAGNETIC FIELD VALUES IN mG
MEASURED ONBOARD COACHES
AT DIFFERENT OPERATING CONDITIONS

FREQUENCY BAND	TRAIN AT REST	DC SECTION	DC TO AC TRANSITION	AC SECTION
	19 SAMPLES TGV001	29 SAMPLES TGV001, 012 & 024	10 SAMPLES TGV001	252 SAMPLES TGV001, 002, 012, 020, 021 & 024
STATIC	813.05	3065.40	1057.78	962.25
5-45 Hz LOW FREQ	2.96	63.09	30.13	106.21
50-60 Hz PWR FREQ	0.65	5.61	2.86	164.68
65-300 Hz PWR HARM	2.01	7.22	4.70	10.40
305-2560 Hz HIGH FREQ	1.76	4.27	4.20	5.40
5-2560 Hz ALL FREQ	4.00	63.15	30.17	165.02

are summarized in Tables 3-4 and 3-5. Table 3-4 summarizes the log entries for passing trains. Table 3-5 displays the log entries for electrical equipment passed by the train. Examination of the data taken during those time periods shown in the tables does not reveal any detectable change in the 50 Hz field levels.

Figure 3-4 is a plot of the magnetic flux density versus distance from the floor and time in the same 1st Class salon for dataset TGV001. It shows clearly that the field is larger at head height (160 cm) than at the floor (10 cm) for the power frequencies, the 50 Hz - 60 Hz fundamental. The same is true for the other datasets in the same location (e.g., TGV002). The power harmonics plot at the bottom of Figure 3-4 follows the same general trend, but with some slight discrepancies.

Examination of vertical data sets for the other cars (TGV012 for Coach R2; TGV020, -21, -24 for Coach R5) also reveals a larger field closer to the ceiling for the power frequency components. Figure 3-5 shows this variation with height for the combined data from all three coaches, for the power frequency range of values. The figure displays the maximum, average and minimum values of the field versus distance. Figure 3-6 shows the same effect of field

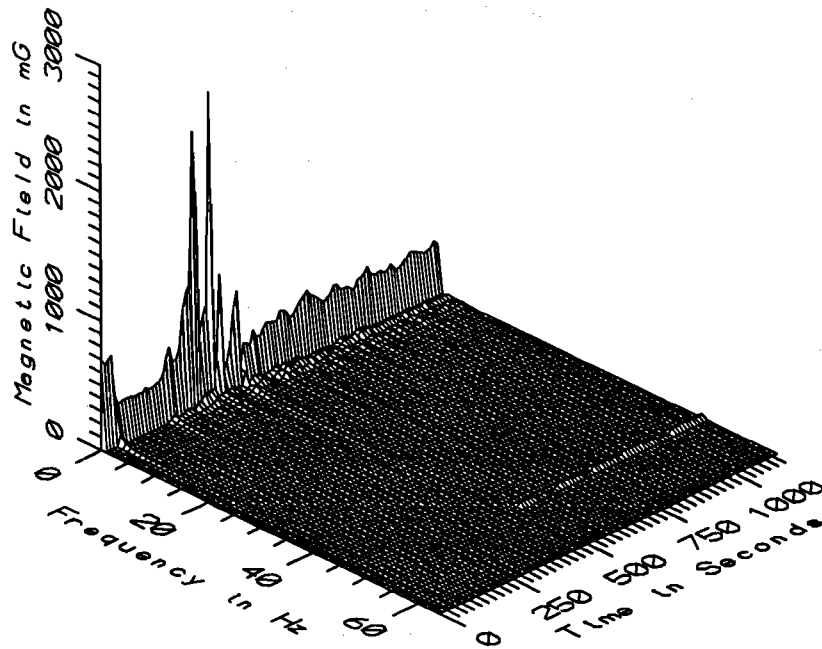

TGV001 - 60cm ABOVE FLOOR IN CENTER OF AISLE AT FRONT OF COACH R1B

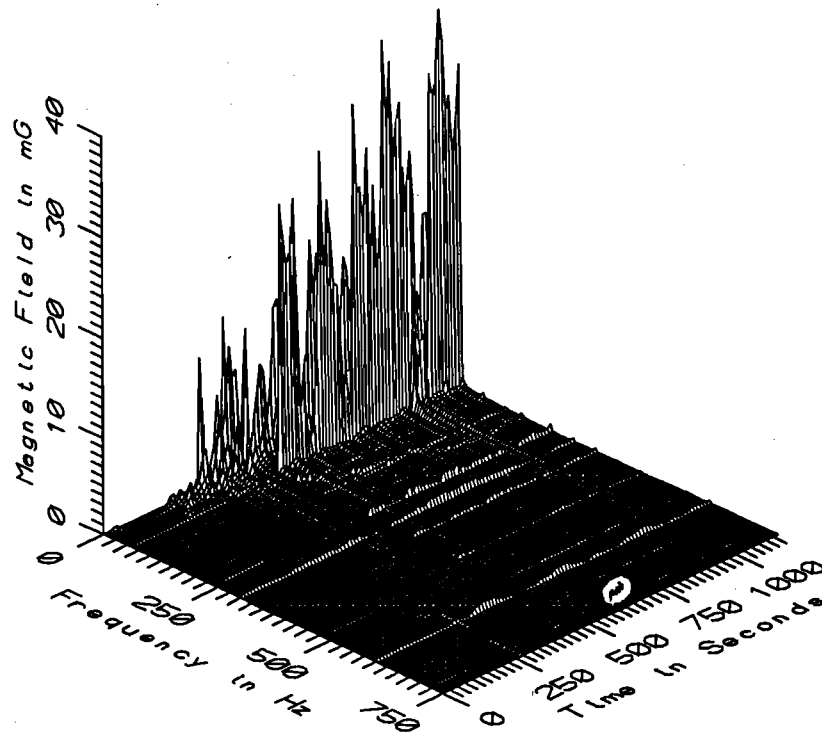

TGV001 - 60cm ABOVE FLOOR IN CENTER OF AISLE AT FRONT OF COACH R1B

FIGURE 3-3. MAGNETIC FIELD LEVEL, WITH AND WITHOUT THE STATIC COMPONENT, I.E., TRANSITION FROM DC TO AC TRACK SECTIONS AT APPROXIMATELY 500 SECONDS, AT 60 cm HEIGHT ABOVE THE FLOOR IN THE FIRST COACH AS A FUNCTION OF FREQUENCY AND TIME

TABLE 3-4.

**LOG OF PASSING TRAINS
AS SEEN FROM ONBOARD THE COACHES
FOR THE DIFFERENT DATASETS**

DATASET #	TIME-INTO-RUN SECONDS	APPROX TIME OF DAY
TGV001	480	08:05
TGV001	600	08:07
TGV001	1080	08:15
TGV002	120	08:19
TGV021	5	17:17
TGV024	300	17:43
TGV024	600	17:48

TABLE 3-5.

**LOG OF POWER SUPPLY EQUIPMENT PASSED
WHILE ONBOARD THE COACHES
FOR THE DIFFERENT DATASETS**

DATASET #	TYPE OF EQUIPMENT	RUN TIME (SECONDS)	km MARKER
TGV001	POWER LINES	660 TO 720	17 TO 24
TGV001	SUBSTATION LES CARRES	720	23
TGV003	HV TRANSFORMER (SUB. GAULT-ST- DENIS)	180	94
TGV021	AUTOTRANSFORMERS (LE BOIS)	260	155
TGV024	TRANSMISSION LINES	420	NOT NOTED
TGV024	SUBSTATION (LES CARRES)	450 TO 480	NOT NOTED
TGV024	12 TRANSMISSION LINES AT RIGHT	570	NOT NOTED
TGV024	PASSENGER STATION AT LEFT	660	NOT NOTED

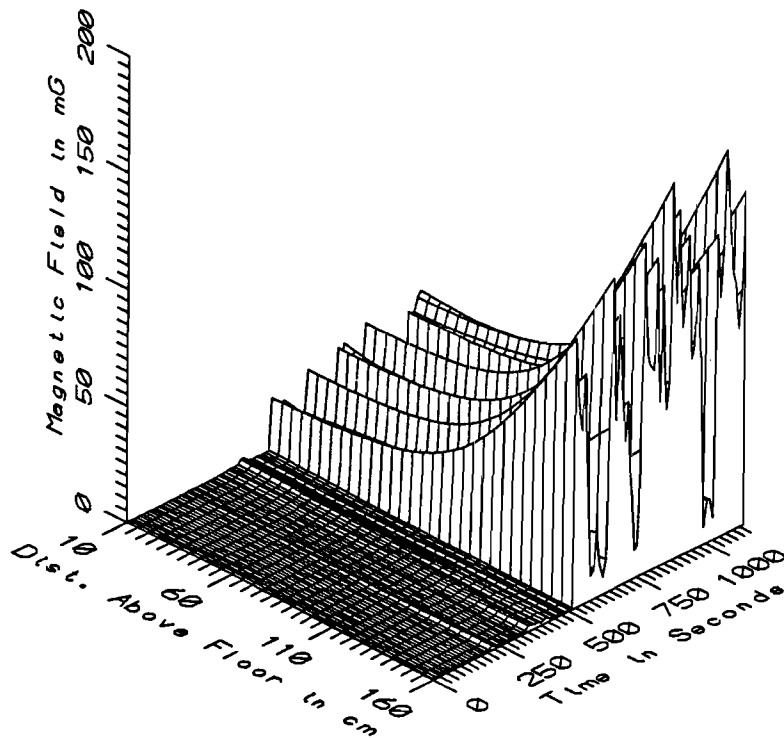

TGV001 - CENTER OF AISLE AT FRONT OF COACH R1B - POWER FREQ, 50-60Hz

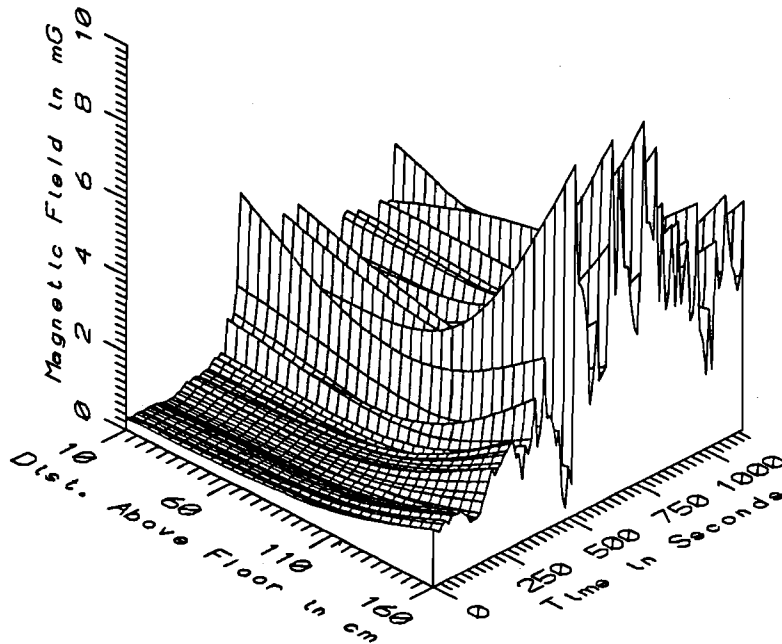

TGV001 - CENTER OF AISLE AT FRONT OF COACH R1B - POWER HARM, 65-300Hz

FIGURE 3-4. VERTICAL PROFILE OF POWER FREQUENCY (50-60 Hz) AND POWER HARMONICS MAGNETIC FIELDS OVER TIME IN THE FIRST COACH

ALL COACHES - VERTICAL

Power Freq. (50 - 60 Hz)

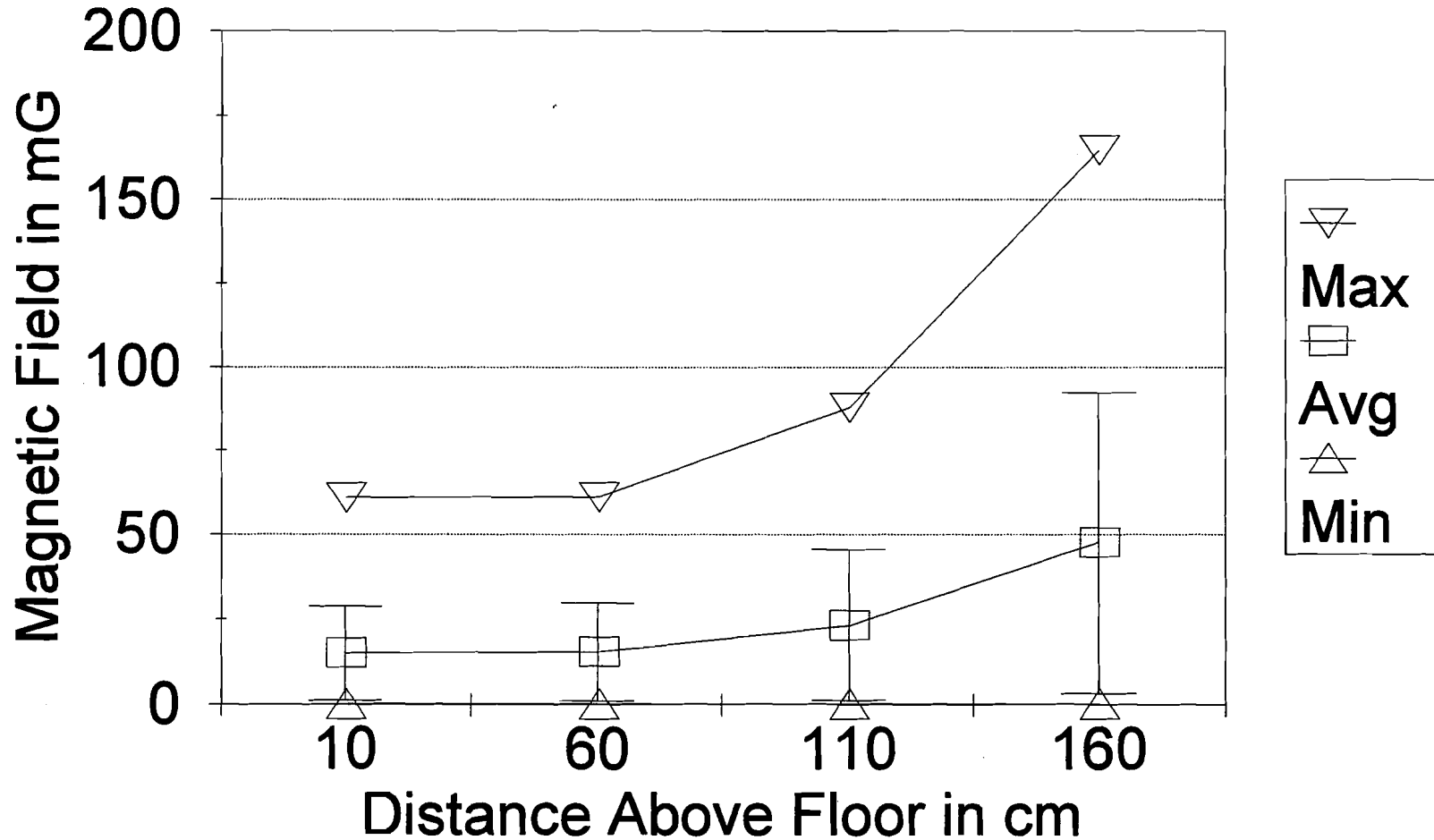

3-12

FIGURE 3-5. VERTICAL PROFILE OF POWER FREQUENCY (50-60 Hz) MAGNETIC FIELDS FOR ALL COACHES

ALL COACHES - AVERAGE FIELDS

Power Freq. (50 - 60 Hz)

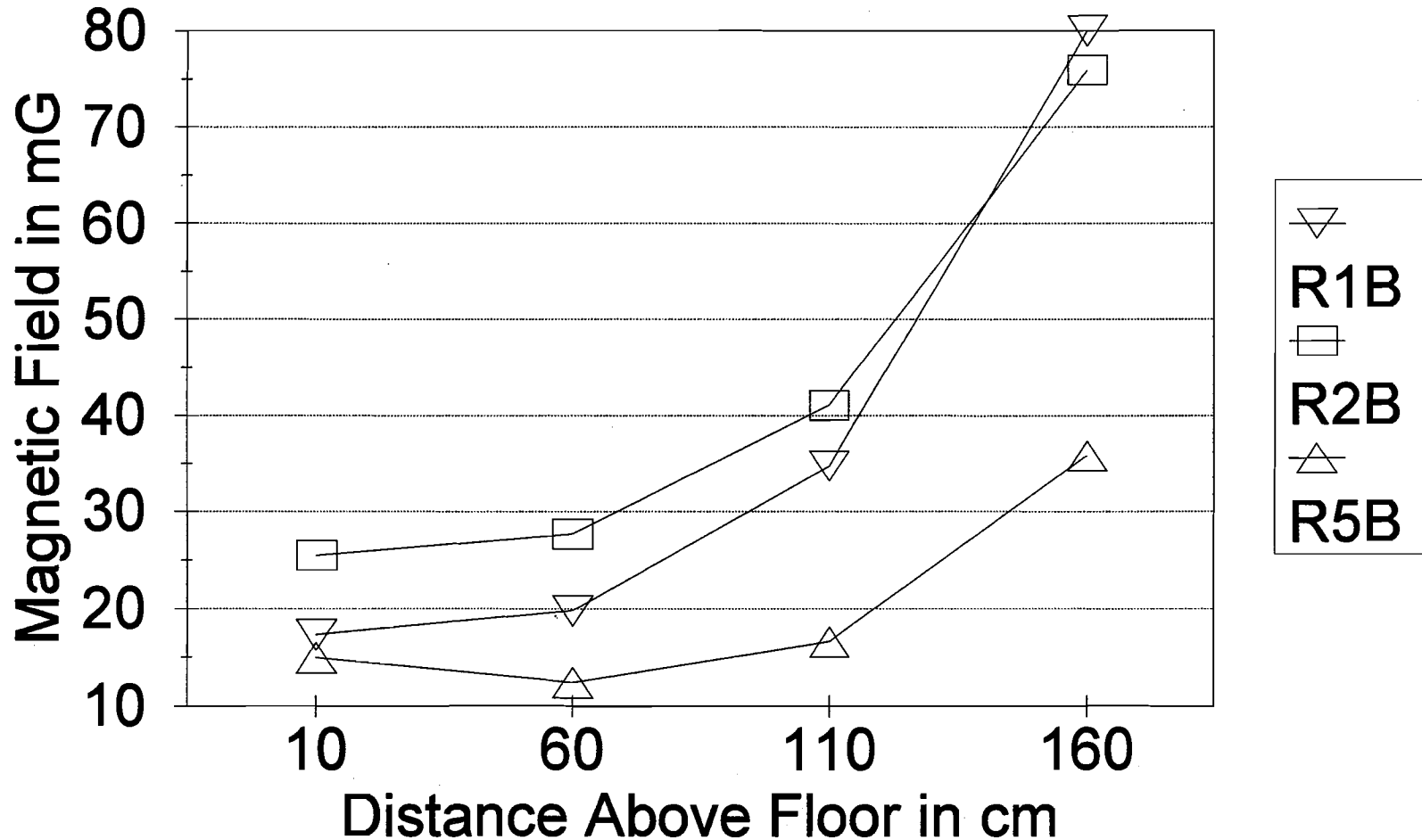

3-13

FIGURE 3-6.

VERTICAL PROFILE OF AVERAGE VALUE OF POWER FREQUENCY (50-60 Hz) MAGNETIC FIELDS FOR THE THREE COACHES

variation with height for each coach, but only for the average values in the power frequency range. The data samples used in both Figures 3-5 and 3-6 were taken from the ac powered section of the track.

These data indicate that the main 50 Hz magnetic field, at least near the ceiling of the coach, comes from the 25 kV ac line in the middle of the ceiling. Current in the catenary and track circuit appears to produce a more spatially uniform 50 Hz field which is apparent at the measurement points nearer the floor of the coaches. The extent to which the 3-phase, 380 V ac (for auxiliary onboard equipment) power cables in the corner of the ceiling contribute to the 50 Hz field cannot be accurately determined. These data also indicate that the power harmonics come from two distinctly different sources: the main 25 kV power cable on top of the car, which contains the harmonic currents of the equipment tied to it, including rectifiers and traction power electronics; and the harmonics from a source beneath the coaches, either a cable beneath the floor or the return current in the tracks. Datasets TGV001, TGV012 and TGV025 show the even harmonic frequency components at the 160 cm level. These are the 300, 600, 900, 1200 Hz, etc frequencies. The same harmonics are not distinguishable at the 10 cm level, which indicates the presence of these harmonics in the conductors in the ceiling.

The distribution of the power frequency magnetic field strength in the cars at various distances from the locomotive was examined. Nine datasets that were from either the vertical or axial positions and in the center of the aisle were examined for attenuation trends. These were datasets TGV001, TGV002, TGV003, TGV012, TGV014, TGV020, TGV021, TGV023 and TGV024, and correspond to locations in three different coaches. Since these datasets were not measured simultaneously, comparisons were done on a statistical basis. Figure 3-7 shows a plot of the maximum, average and minimum magnetic field levels in the power frequency band for three distances. This frequency band contains the fundamental frequency of the ac power supply, 50 Hz. The statistics were obtained by averaging all four sensors of the staff, for all applicable datasets. As can be seen in the figure, both the average and maximum magnetic field values appear to show some attenuation in the fifth car. No appreciable difference exists between the first two cars.

As described earlier, the principal magnetic field source inside the coaches appears to be current in the catenary and track circuit which includes the pantographs, 25 kV cabling along the top of the coaches, and the locomotive circuitry on the primary side of the main transformer. In the coaches, the significant field sources are the current in the catenary, current in the 25 kV cables on top of the coaches, and current in the tracks. Those components of the power supply system are identical in all three coaches and should therefore produce similar magnetic field levels. Without examining the conditions under which the measured data were recorded, these predictions would not seem to be supported.

ALL COACHES - POWER FREQUENCY

All Probe Locations

3-15

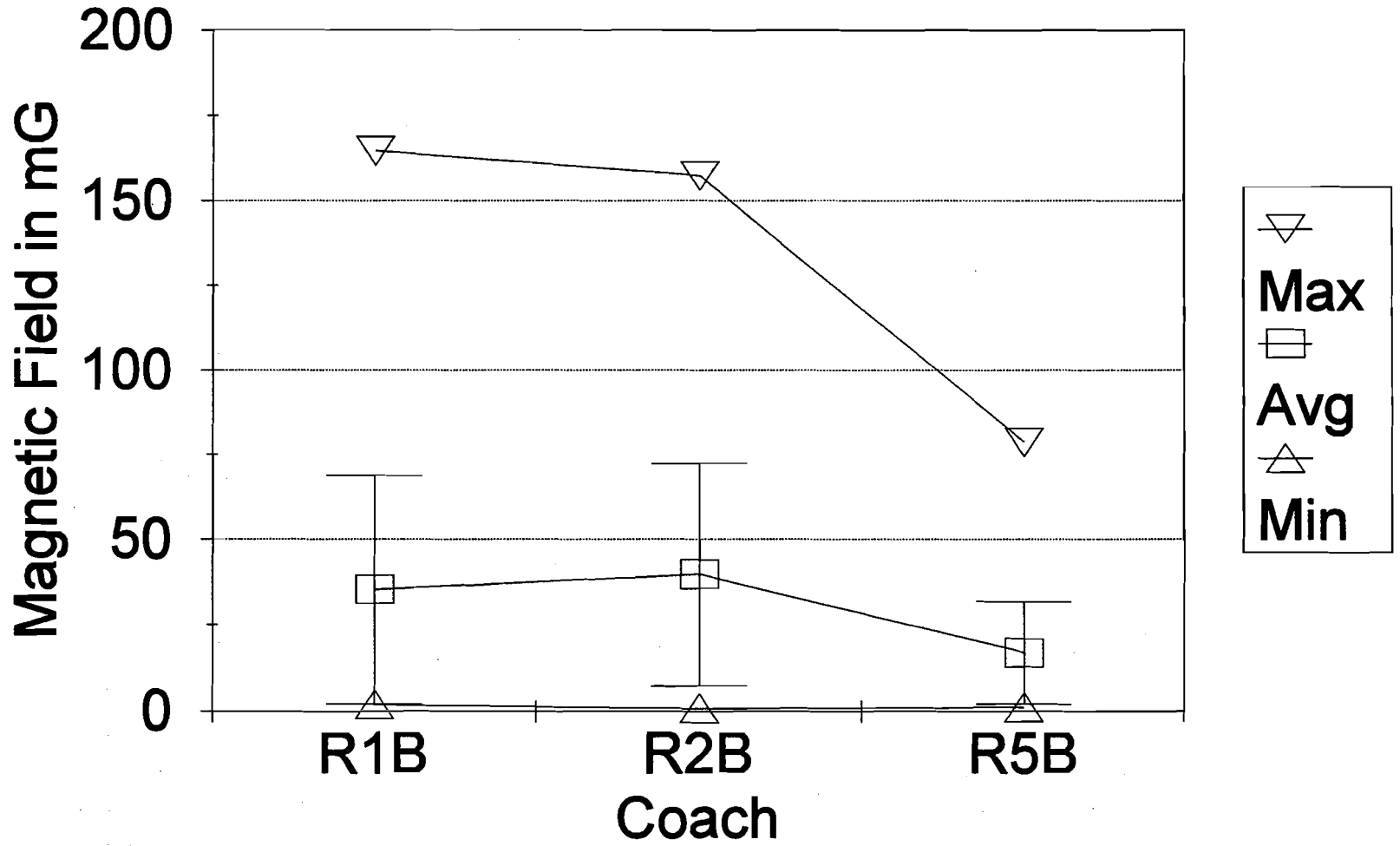

FIGURE 3-7. MAGNETIC FIELD LEVEL OF POWER FREQUENCY (50-60 Hz) COMPARISON AMONG THE COACHES

However, examination of the measurement sequence reveals that measurements were made in Coaches R1 and R2 while traveling toward Tours, and in Coach R5 while traveling toward Paris. Thus, field level differences are not due to the position of the coach within the train set, but whether measurements were made in the leading or trailing train set. The measurements in Coaches R1 and R2 were made while traveling toward Tours, which places them in the rear train set (see Figure 3-1). Since only the pantograph of the rear locomotive in each train set is in use, the coaches of the rear train set are between the two pantographs. For a significant period of time after passing an autotransformer station, current in the catenary (to the front train set) and current in the cable along the tops of the coaches (to the front locomotive of the trailing train set) are in phase and flowing in the same direction thereby producing fields within the coaches which add to one another. However, when in the leading train set, as Coach R5 was during the measurement trip toward Paris, the coach is not between the two pantographs and the directions of the current in the rooftop cable and the overhead catenary are always opposite. Hence, the magnetic field from one source tends to cancel part of the magnetic field from the other.

The geomagnetic field (natural field of the earth) in the vicinity of Paris is 470 mG. This is slightly less than what is seen in the coaches operating on the ac section of the route. Static field levels were markedly higher than the expected geomagnetic field level on the dc portions of the route. Although iron and steel components exist in the coaches, the overriding influence is the dc field produced by either the traction currents during the dc operation or the auxiliary power currents during the ac operation.

Magnetic field measurements were made near the walls and simultaneous measurements towards the center of the coach. These measurements were recorded in order to detect any appreciable variation between the center aisle and the side of the car. The resulting data are in datasets TGV004, TGV013 and TGV022, shown in Appendices E, N and W, respectively. These data are consistent with the measurements near the aisle and with the data measured with the reference probe near the window seats (see position 1, position 16 and position 24 in Figure 3-2). Figure 3-8 depicts the flux level as a function of distance from wall. This plot is typical of all three datasets, in that it shows attenuation of the field in both directions, over time. Table 3-6 shows the power frequency range maxima and average values for the three datasets and for the combined total. The three maxima are 59.40, 66.43 and 45.25 mG, all occurring near the wall. Figure 3-8 is a plot of these data along with the minimum values. Overall, the data indicate that there is a tendency for slightly higher levels near the wall. Since this point was usually at a window, the increased field may be due to passive field enhancement by the ferromagnetic coach body above and below the gap produced by the window.

ALL COACHES, TRANSVERSE

Power Freq. (50 - 60 Hz)

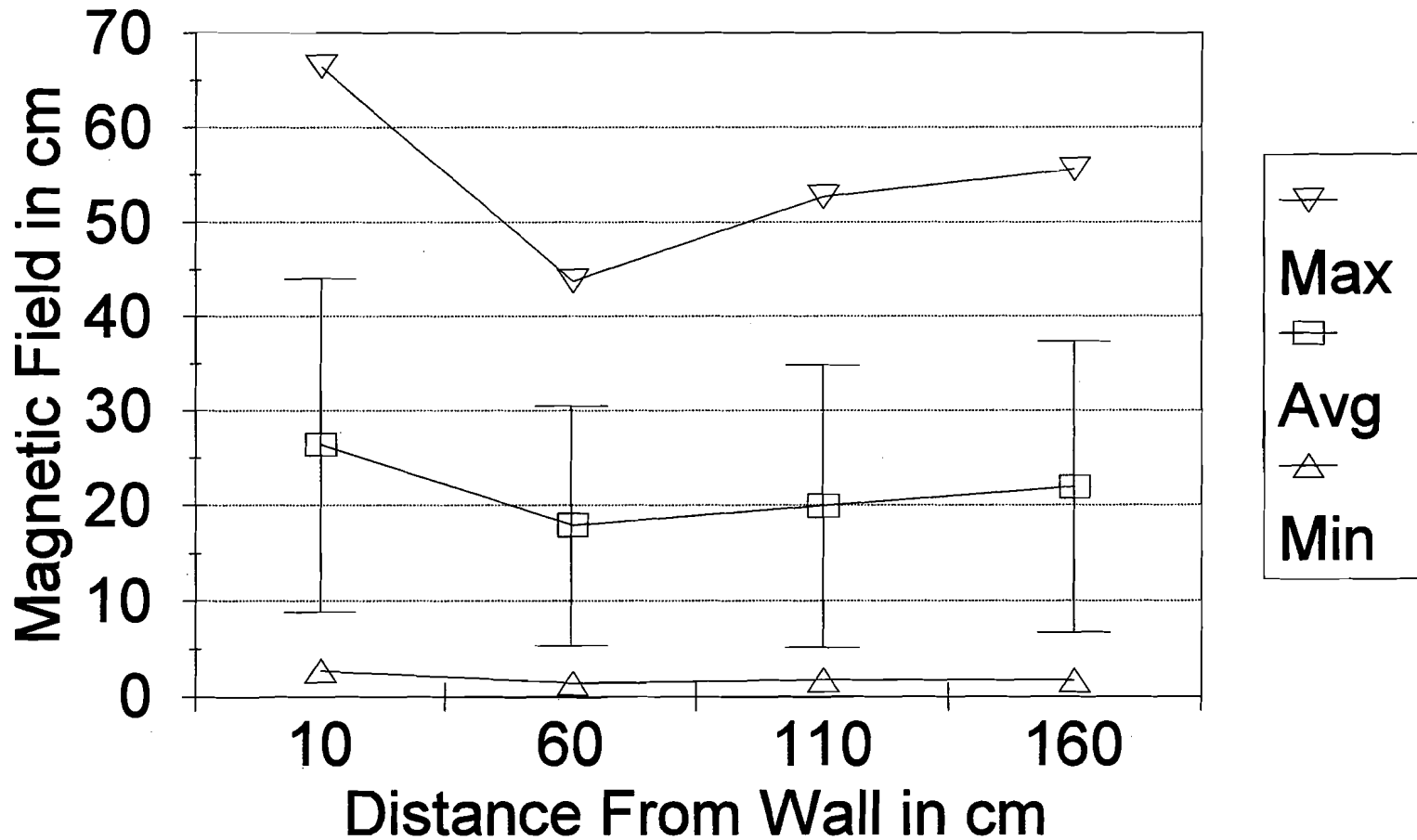

3-17

FIGURE 3-8. TRANSVERSE PROFILE OF POWER FREQUENCY (50-60 Hz) MAGNETIC FIELDS FOR ALL COACHES

TABLE 3-6.

**MAXIMUM AND AVERAGE MAGNETIC FIELD VALUES
OF THE POWER FREQUENCY RANGE
ON A TRANSVERSE PROFILE INSIDE THE COACHES
FOR THE THREE CARS AND THE COMBINATION**

	TGV004 CAR 1	TGV013 CAR 2	TGV022 CAR 5	COMBINED DATASET
MAXIMUM				
10 cm	59.40	66.43	59.73	66.43
60 cm	35.11	43.76	19.50	43.76
110 cm	38.08	52.63	15.26	52.63
160 cm	39.72	55.58	19.80	55.58
AVERAGE				
10 cm	29.69	30.50	19.04	26.41
60 cm	17.76	28.10	7.89	17.92
110 cm	18.66	32.94	8.32	19.97
160 cm	20.67	34.97	10.23	21.96

3.4 DAT WAVEFORM DATA

Magnetic field data from the reference probe of the waveform capture system was recorded continuously with a Digital Audio Tape Recorder, as described in Section 2.5. Continuous field data were measured in Coaches R1, R2, and R5 periodically during the trip between Paris and St. Pierre-des-Corps and between Paris and Vendome. Table 2-2 shows the pertinent data on those recordings, which are identified as Tape and Record 1-1, 2-2, and 3-1. Those recordings were continuously scanned for transient fields or sudden, brief excursions in field level which could be missed by the periodic sampling of the waveform capture system. Neither transient fields nor short term deviations in field level were detected.

A statistical summary of rms magnetic field levels in the pass band of the DAT Recording System (0.1 Hz to 2.5 kHz) recorded in the coaches is presented in Table 3-7. These values tend to be higher than those reported for the statistical analysis of the waveform capture system data because of the difference in effective low frequency bandwidth brought about by the different analysis techniques (0.1 Hz for the DAT data analysis and 2.5 Hz for the waveform capture system analysis). As Figure 3-3 indicates, the magnetic fields in the coaches contain considerable amounts of

TABLE 3-7.

SUMMARY OF MAGNETIC FIELD LEVELS RECORDED
IN A PASSENGER SEAT OF A COACH RECORDED WITH
THE DIGITAL AUDIO TAPE RECORDER (DAT)

COACH AND SECTION	MEASUREMENT LOCATION		TIME VARYING MAGNETIC FIELD MILLIGAUSS, RMS		
	FIGURE #	LOCATION	MINIMUM	AVERAGE	MAXIMUM
FIRST DC SECTION (1-1)	3-2	4	7.6	34.5	203.7
FIRST AC SECTION (1-1)	3-2	4	14.3	67.4	273.4
SECOND DC SECTION (2-2)	3-2	16	8.1	30.9	165.0
SECOND AC SECTION (2-2)	3-2	16	16.6	64.4	222.1
FIFTH DC SECTION (3-1)	3-2	24	3.29	19.4	66.3
FIFTH AC SECTION (3-1)	3-2	24	1.5	53.4	156.3

ultra low frequency (ULF) field. Since the analysis technique used to calculate the rms value of the field waveform data recorded by the DAT produces more response at low frequencies than the technique used with waveform capture system, these low frequency components are included in the calculation of total rms field in Table 3-7, producing values somewhat larger than those reported for the waveform capture system measurements. In locations without significant ULF time varying field components such as in the locomotives, the rms field values reported from DAT and waveform capture system measurements are nearly identical.

3.5 RMS RECORDER DATA

Magnetic field levels measured by the waveform capture system or Digital Audio Tape Recorder provide detailed documentation of magnetic field levels at a few discrete locations within the

coaches but do not factor in the possibility that passengers moving about the coaches may encounter high fields from specific, localized sources. To examine the extent to which spot measurements of magnetic fields can be generalized to passenger exposure, one, and sometimes two, members of the measurement team wore rms personal magnetic field exposure monitors.

The rms monitors lack the ability to resolve the frequency characteristics of the magnetic field, recording instead the total magnetic field level within a particular frequency range. For these tests, the instruments were used in the "broadband" mode which yielded the widest frequency response (nominally a 3 db bandwidth between 40 Hz and 800 Hz) and therefore, provided the instrument's most complete measurement of ELF magnetic fields.

The rms units were carried, mostly waist high, while wandering about the approximate vicinity of the other measurements. The only exception is during trip 4, when the Coach 5 data were measured. On this trip one of the people wearing an rms recorder was in a different part of the train; therefore, the statistics of the two simultaneous measurements were not combined.

Table 3-8 shows the statistical minimum, average and maximum values obtained by the rms recorders onboard the coaches. Three sets of recordings are summarized, corresponding to the trips in the three different coaches. The values of the magnetic field summaries are in mG. Only the recordings made while the train was operating in the ac powered portion of the railroad are included in these statistics.

3.6 SUMMARY OF MAGNETIC FIELD LEVELS

As discussed in the preceding subsections, currents in the power supply lines in the roofs of the coaches, in the catenary, and in the track are the principal sources of time-varying magnetic fields within the coaches.

There is significant static magnetic field production within the coaches during travel through the dc section of the line.

Tables 3-9 through 3-12 summarize the measured field levels in four meaningful ways, combining the statistics of all the coaches. Each table shows the minimum, maximum and average field levels as well as the standard deviation and the coefficient of variation for the repetitive waveform datasets listed in the title heading. Each table provides the statistics for the four measurement locations along the staff and for five adjacent frequency ranges, as well as the overall ELF frequency range.

TABLE 3-8.

STATISTICAL SUMMARY OF MAGNETIC FIELD LEVELS
RECORDED IN ALL COACHES USING
RMS RECORDERS

LOCATION	RMS RECORDER #	MINIMUM	AVERAGE	MAXIMUM
1ST COACH				
	PERSON 1	0.10	15.44 *	252.80 *
	PERSON 2	0.10	9.38	47.00
	COMBINED	0.10	12.51	252.80
2ND COACH				
	PERSON 1	0.10	22.26 *	81.40 *
	PERSON 2	0.10	13.46	57.80
	COMBINED	0.10	17.89	81.40
5TH COACH				
	PERSON 1	0.20 **	15.36 **	152.40 **
	PERSON 2	0.20	8.68	131.20

* Note that there is a large difference between the two recordings. The reason for this is that Person 1 was intentionally surveying and experimenting in trying to find local high field sources by walking around the coach and placing the rms recorder up against electrical equipment and cabinets. Person 2 kept the recorder at waist level and continued to conduct other measurements.

** During most of the trip on which measurements were made in Coach 5, Person 1 stayed in another part of the train. Hence, the two recordings were not combined.

TABLE 3-9.

SUMMARY STATISTICS FOR ALL VERTICAL DATASETS FOR ALL COACHES MEASURED WHILE TRAVELLING
ALL SECTIONS OF THE LINE (DATASETS TGV001, 002, 012, 020, 021 AND 024)

TGV001, 002, 012, 020, 021, 024 - ALL COACHES - ALL SAMPLES					TOTAL OF 322 SAMPLES	
FREQUENCY BAND	HEIGHT ABOVE FLOOR (cm)	MINIMUM MAGNETIC FIELD (mG)	MAXIMUM MAGNETIC FIELD (mG)	AVERAGE MAGNETIC FIELD (mG)	STANDARD DEVIATION (mG)	COEFFICIENT OF VARIATION (%)
STATIC	10	140.82	2670.86	476.99	278.88	58.47
	60	109.82	2387.63	534.68	226.34	42.33
	110	37.37	2272.85	572.43	246.22	43.01
	160	138.85	3065.39	673.82	300.84	44.65
5-45Hz LOW FREQ	10	0.19	106.21	29.64	20.85	70.34
	60	0.17	66.88	19.86	13.32	67.06
	110	0.12	58.65	16.47	10.87	65.99
	160	0.22	47.39	13.38	8.14	60.81
50-60Hz PWR FREQ	10	0.13	60.97	14.31	13.60	95.03
	60	0.17	61.10	14.61	14.25	97.56
	110	0.16	87.84	22.17	21.92	98.88
	160	0.24	164.68	45.35	43.88	96.76
65-300Hz PWR HARM	10	0.24	10.40	2.68	1.91	71.10
	60	0.30	7.42	1.96	1.23	62.81
	110	0.37	5.54	2.01	1.04	51.91
	160	0.31	9.30	2.88	1.62	56.34
305-2560Hz HIGH FREQ	10	0.18	4.92	1.34	0.84	63.09
	60	0.16	3.27	1.04	0.52	50.13
	110	0.18	2.68	1.14	0.48	41.88
	160	0.14	5.40	1.83	1.06	57.88
5-2560Hz ALL FREQ	10	0.44	106.67	35.04	22.10	63.06
	60	0.53	71.58	26.79	16.64	62.13
	110	0.80	92.00	30.22	21.32	70.56
	160	1.11	165.02	49.85	41.92	84.09

TABLE 3-10.

SUMMARY STATISTICS FOR ALL VERTICAL DATASETS FOR ALL COACHES MEASURED WHILE TRAVELLING THE DC SECTIONS OF THE LINE (DATASETS TGV001, 012, AND 024)

TGV001, TGV012, TGV024 - ALL COACHES - ALL DC SAMPLES					TOTAL OF 29 SAMPLES	
FREQUENCY BAND	HEIGHT ABOVE FLOOR (cm)	MINIMUM MAGNETIC FIELD (mG)	MAXIMUM MAGNETIC FIELD (mG)	AVERAGE MAGNETIC FIELD (mG)	STANDARD DEVIATION (mG)	COEFFICIENT OF VARIATION (%)
STATIC	10	273.91	2670.86	973.42	682.02	70.07
	60	109.82	2387.63	797.03	587.74	73.74
	110	196.31	2272.85	799.61	571.08	71.42
	160	138.85	3065.39	1081.01	682.83	63.17
5-45Hz LOW FREQ	10	1.45	63.09	15.17	18.08	119.19
	60	1.18	28.01	8.53	8.48	99.41
	110	1.09	19.96	6.97	6.08	87.24
	160	0.89	19.11	7.37	5.10	69.16
50-60Hz PWR FREQ	10	0.28	5.61	1.27	1.47	115.29
	60	0.28	2.72	0.76	0.65	84.87
	110	0.35	2.18	0.85	0.48	56.27
	160	0.35	3.42	1.20	0.76	63.64
65-300Hz PWR HARM	10	0.40	7.22	1.50	1.72	115.14
	60	0.31	3.42	0.99	0.77	77.58
	110	0.38	2.93	1.20	0.53	44.36
	160	0.46	3.55	2.33	0.58	24.95
305-2560Hz HIGH FREQ	10	0.20	3.22	0.81	0.75	93.12
	60	0.16	1.62	0.70	0.39	55.60
	110	0.22	1.72	0.95	0.41	43.21
	160	0.33	4.27	2.08	1.07	51.35
5-2560Hz ALL FREQ	10	1.61	63.15	15.38	18.18	118.22
	60	1.32	28.06	8.72	8.48	97.18
	110	1.26	20.10	7.31	5.98	81.81
	160	1.11	19.32	8.38	4.81	57.43

TABLE 3-11.

SUMMARY STATISTICS FOR ALL VERTICAL DATASETS FOR ALL COACHES MEASURED WHILE TRAVELLING THE AC SECTIONS OF THE LINE (DATASETS TGV001, 002, 012, 020, 021 AND 024)

TGV001, 002, 012, 020, 021, 024 - ALL COACHES, ALL AC SAMPLES					TOTAL OF 252 SAMPLES	
FREQUENCY BAND	HEIGHT ABOVE FLOOR (cm)	MINIMUM MAGNETIC FIELD (mG)	MAXIMUM MAGNETIC FIELD (mG)	AVERAGE MAGNETIC FIELD (mG)	STANDARD DEVIATION (mG)	COEFFICIENT OF VARIATION (%)
STATIC	10	165.41	616.00	426.78	104.55	24.50
	60	310.21	759.11	528.41	107.06	20.26
	110	243.42	763.46	575.32	158.92	27.62
	160	294.30	962.24	649.37	188.19	28.98
5-45Hz LOW FREQ	10	0.88	106.21	34.81	19.14	55.00
	60	0.67	66.88	23.52	12.10	51.46
	110	0.73	58.65	19.50	9.92	50.86
	160	0.85	47.39	15.54	7.43	47.78
50-60Hz PWR FREQ	10	1.50	60.97	17.98	13.17	73.25
	60	0.86	61.10	18.48	13.80	74.67
	110	1.00	87.84	28.11	21.24	75.58
	160	0.75	164.68	57.60	42.05	73.02
65-300Hz PWR HARM	10	0.43	10.40	3.10	1.81	58.47
	60	0.47	7.42	2.27	1.17	51.62
	110	0.64	5.54	2.28	0.98	43.03
	160	0.69	9.30	3.16	1.68	53.11
305-2560Hz HIGH FREQ	10	0.31	4.92	1.53	0.81	52.84
	60	0.23	3.27	1.16	0.50	43.00
	110	0.34	2.68	1.23	0.46	37.10
	160	0.39	5.40	1.88	1.08	57.78
5-2560Hz ALL FREQ	10	3.47	106.67	41.62	18.91	45.44
	60	1.86	71.58	32.31	13.99	43.32
	110	4.07	92.00	36.93	19.05	51.60
	160	7.23	165.02	61.78	39.77	64.37

TABLE 3-12.

SUMMARY STATISTICS FOR ALL TRANSVERSE DATASETS FOR ALL COACHES MEASURED WHILE TRAVELLING THE AC SECTIONS OF THE LINE (DATASETS TGV004, 013, AND 022)

TGV004, 013, 022 - ALL COACHES, TRANSVERSE DATASETS					TOTAL OF 30 SAMPLES	
FREQUENCY BAND	DIST. FROM SIDE (cm)	MINIMUM MAGNETIC FIELD (mG)	MAXIMUM MAGNETIC FIELD (mG)	AVERAGE MAGNETIC FIELD (mG)	STANDARD DEVIATION (mG)	COEFFICIENT OF VARIATION (%)
STATIC	10	340.42	778.93	527.05	165.72	31.44
	60	28.82	665.44	369.77	234.31	63.37
	110	197.94	707.13	454.56	188.68	41.51
	160	366.80	694.75	558.29	123.78	22.17
5-45Hz LOW FREQ	10	10.32	52.46	26.81	9.76	36.41
	60	8.32	45.66	24.29	9.49	39.06
	110	8.31	49.09	24.86	10.18	40.93
	160	8.79	49.85	25.33	10.29	40.62
50-60Hz PWR FREQ	10	2.72	66.43	26.41	17.64	66.79
	60	1.39	43.76	17.92	12.61	70.39
	110	1.76	52.63	19.97	14.84	74.30
	160	1.71	55.58	21.96	15.33	69.82
65-300Hz PWR HARM	10	0.95	6.38	2.73	1.13	41.56
	60	0.96	4.61	2.02	0.97	48.15
	110	1.06	4.87	2.13	1.03	48.17
	160	0.97	5.01	2.22	1.07	48.11
305-2560Hz HIGH FREQ	10	0.54	3.53	1.57	0.62	39.65
	60	0.43	2.20	1.03	0.48	46.05
	110	0.50	2.39	1.11	0.51	46.33
	160	0.55	2.50	1.17	0.55	46.55
5-2560Hz ALL FREQ	10	14.93	84.96	40.06	14.92	37.23
	60	10.82	59.47	32.16	11.34	35.27
	110	11.63	61.27	34.19	13.18	38.55
	160	12.23	62.98	35.86	13.45	37.52

Table 3-9 displays the statistics for all the vertical position staff measurements in all of the coaches and for all sections of the line, shown for the four heights. The maximum static field was 3066 mG and the maximum ac field was 165 mG, occurring in the power frequency range. Both of these maxima occur at the highest staff position.

Table 3-10 has the overall statistics of all the vertical position measurements taken on the dc powered section of the line. As expected, the static field maximum is precisely the same as in the Table 3-9, i.e., 3066 mG, occurring at the highest staff sensor location. On the other hand, the maximum ac field was 63 mg, occurring in the low frequency range and at the lowest point of the staff. Table 3-11 displays the corresponding statistics of magnetic field measurements made during the run on the ac powered section of the line. As expected, the static maximum is lower than before and the ac maximum occurs in the power frequency range. The maximum values are 962 mG (static) and 165 mg (power frequency), both occurring closest to the coach roof.

Table 3-12 presents the overall results for the transverse measurements. All these data were taken while the train was running on the ac powered section of the line. The four distances along the staff are shown as distances from the wall of the car. Since the overall inside width dimension of the car is 2.9 m (9.5 ft), the midpoint (1.45 M (4.8 Ft)) falls between the third and fourth sensors, just short of the fourth sensor at 1.6 m (5.2 ft). The maximum static component is 779 mG, occurring closest to the wall. The maximum ac magnetic field value of 66 mg occurred at the wall, in the power frequency range.

3.7 ELECTRIC FIELD SOURCES AND LEVELS

Ultra low frequency (ULF) and extreme low frequency (ELF) electric fields are effectively attenuated by conductive barriers such as the metallic bodies of the TGV-A coaches. Consequently, significant electric fields from external sources associated with the railroad or the commercial power system were not expected to be present inside the coaches.

Figure 3-9 shows the electric field as measured with the staff in position 1 (see Figure 3-2) at 170 cm above the floor. As the instrument does not measure static fields, what is shown at the very low frequencies is transient changes in the static field due to, for instance, motion of the researchers. There is a very small 50 Hz field present, less than 0.1 V/m, that is clearly due to the ac train power, because the component changes from zero to this small value at the time that the train goes from the dc to the ac powered sections.

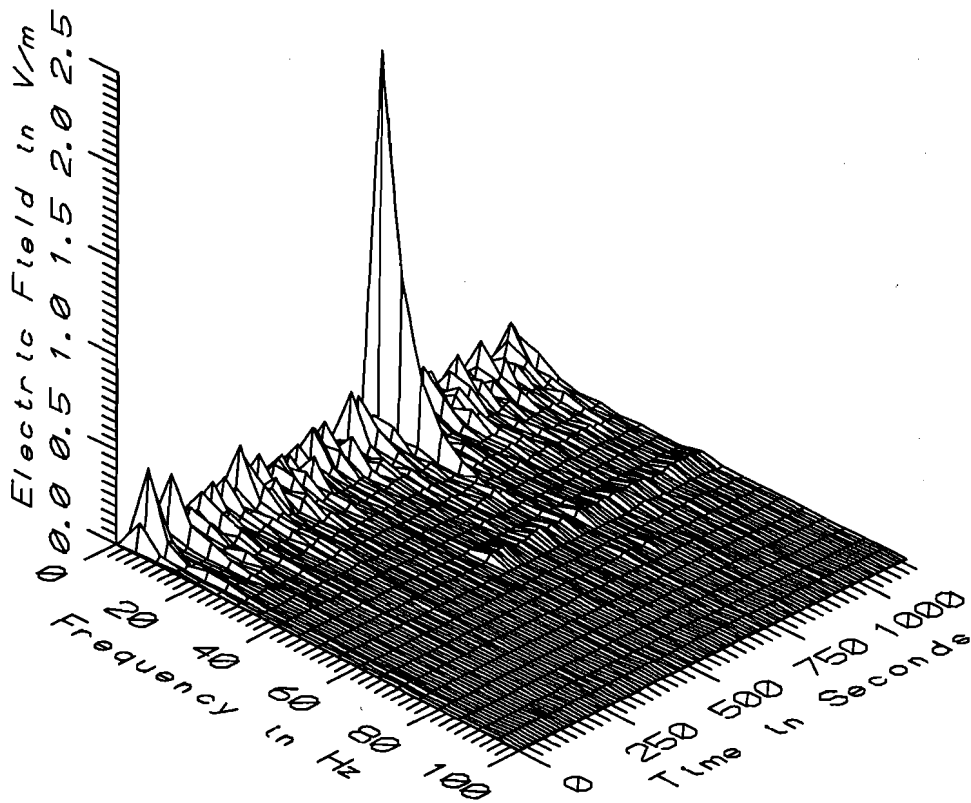

TGV001 - ELECTRIC FIELD IN COACH R1B

FIGURE 3-9. ELECTRIC FIELD LEVEL AS A FUNCTION OF FREQUENCY AND TIME AT 170 cm ABOVE THE FLOOR IN COACH R1B OF THE TGV-A

4. ENGINEER'S COMPARTMENT MEASUREMENTS

The electric and magnetic field measurements in the engineer's compartment address the question of occupational exposure of the engineer. The electric and magnetic field environment of the locomotive cab has contributions from various field sources, as described in the preceding section. However, sources within the locomotive are more likely to be significant contributors to the field environment of the engineer's cab.

The majority of the measurements reported in this section were made in the operational cab of the power car (locomotive) of the test train. Since measurements were not permitted in the coaches of trains in revenue service, and therefore were conducted in an empty test train, it was desirable to also obtain comparative data in the cab of a heavily loaded train in revenue service. Those data are also reported in this section, followed by a discussion of the apparent role of passenger load on magnetic field levels.

4.1 MEASUREMENT LOCATIONS

The principal measurement emphasis in the cab of the locomotive was documentation of magnetic field levels in the vicinity of the engineer. Electric fields received less emphasis because the steel construction of the locomotive shell, the steel bulkhead which separated the cab from the machinery portion of the locomotive, and the steel consoles which house control equipment all serve as effective shields to ELF electric fields.

The top frame of Figure 4-1 shows the approximate locations of the waveform capture system measurement staffs when magnetic field repetitive waveform measurements were made in the front cab of the test train. Four simultaneous measurements at various heights from the floor were measured at the right shoulder of the engineer, indicated as measurement Location 5, to document the vertical profile of field conditions at the side of the engineer nearest the locomotive machinery and equipment. A horizontal profile was measured behind the engineer's seat at a height of 1 m (3.3 ft) above the floor (Location 6 on Figure 4-1) to quantify the lateral variability of the magnetic field in the vicinity of the engineer. Another profile was measured 1.3 m (4.3 ft) above the cab floor along the axial direction going forward from the back bulkhead of the cab. That profile, Location 7, was intended to document the extent to which fields from locomotive machinery enter the cab and the rate at which they attenuate. During all of the tests in the locomotive cab, the reference sensor was placed on the console to the front right of the assistant engineer's seat, indicated as Location 8 in Figure 4-1. Continuous waveform recordings of the magnetic field at the reference sensor location were made with the DAT. One rms recorder was worn by a member of the test team

First Locomotive of Test Train

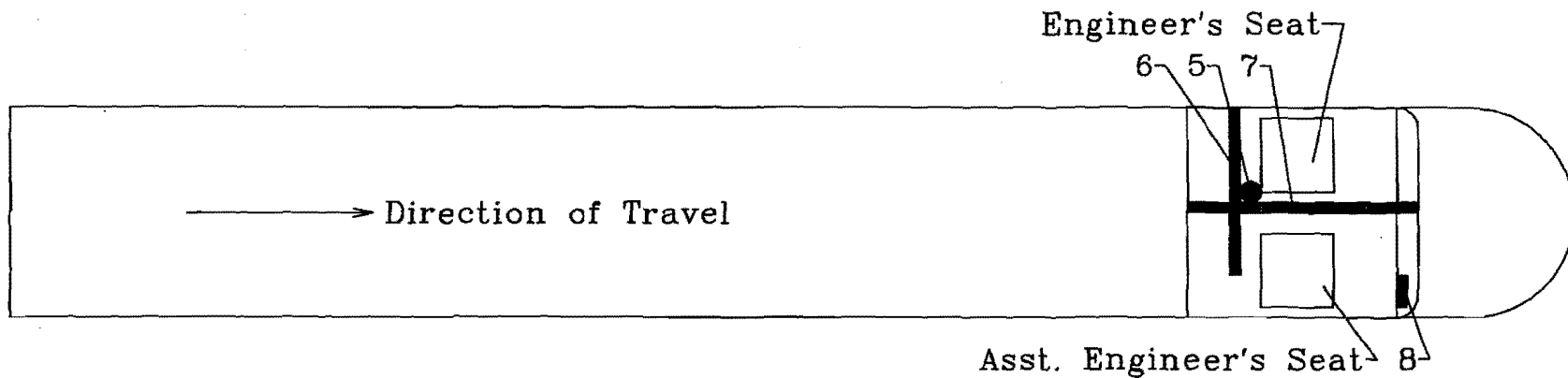

First Locomotive of Revenue Train

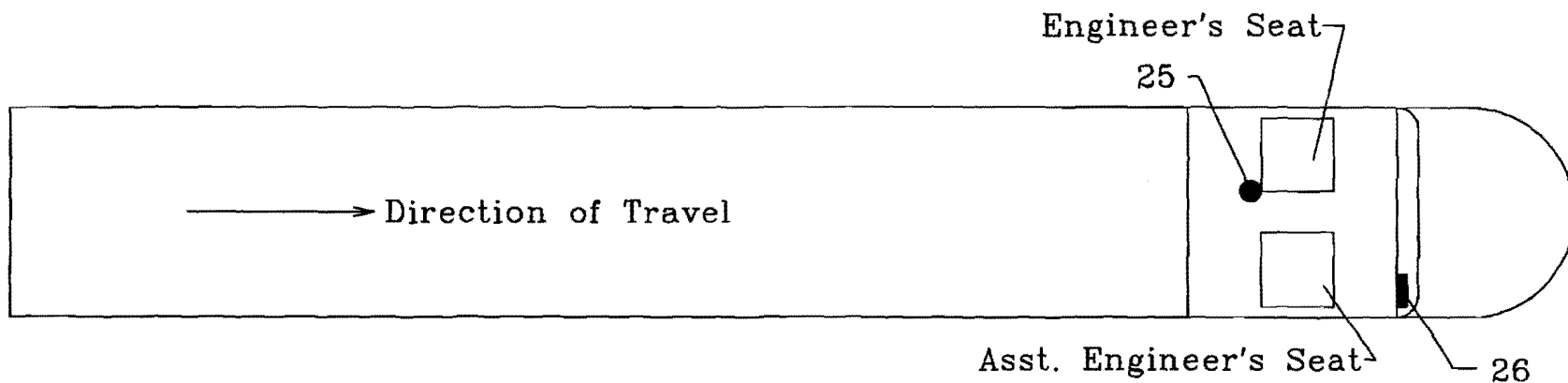

4-2

FIGURE 4-1. FIELD MEASUREMENT LOCATIONS IN THE CAB OF THE TEST TRAIN AND CAB OF A NORMAL SCHEDULED TRAIN IN REVENUE SERVICE

seated in the assistant engineer's seat, while the second was worn by a person who spent time both in the cab and walking around the electrical and mechanical equipment in the machinery portion of the locomotive.

Magnetic field measurements in the cab of the train in typical scheduled revenue service were less extensive than those in the test train. They were intended only as a comparison to account for the effects of passenger load on motive power requirements and, therefore, magnetic field levels. Measurements consisted primarily of repetitive magnetic field waveform measurements at four heights above the floor at the engineer's right shoulder (Location 25 on Figure 4-1) and at a reference location on the console in front of the assistant engineer's seat (Location 26 on Figure 4-1). Continuous recordings of the magnetic field at the reference sensor were made with the DAT and rms recorders which were worn by test personnel in the cab and machinery compartment of the locomotive.

4.2 REPETITIVE WAVEFORM DATASETS

Seven repetitive waveform datasets were collected in the engineer's compartments. These tests were distributed across the cab of the test train and the cab of the train in normal scheduled service, as illustrated in Table 4-1. Note that the sampling is heaviest at the test location next to the engineer's seat where the most routine exposure to magnetic fields occurs. The field-by-frequency-by-time plots and field-by-distance-by-time plots for these datasets are found in the appendices of this report (Volume II). The appropriate appendix is identified on Table 4-1. Comparisons across datasets allow evaluation of the effect of passenger load on field characteristics in the locomotive cab and, to some extent, can be extrapolated to the likely effect of passenger load on magnetic field levels in passenger coaches.

4.3 FIELD SOURCE IDENTIFICATION

Frequency, temporal, and spatial characteristics of the magnetic fields as measured by the repetitive waveform sampling technique provide excellent opportunities for evaluation of various field sources which contribute significantly to the magnetic field environment within the cab. As described in Section 3.3 above, data from comparable measurements with the train operating on the 1.5 kV dc catenary and on the 25 kV, 50 Hz ac catenary add further insight to that process.

Figure 4-2 shows pseudo-three-dimensional graphs of the magnetic field versus frequency and time at a height of 1.1 m (3.6 ft) above the floor at the right of the engineer's seat. These data come from dataset TGV005 (Appendix F) which was measured in locomotive TGV 309 as it departed St. Pierre-des-Corps enroute to Paris on the 1.5 kV dc section of the route. Approximately 400 seconds into

TABLE 4-1.

REPETITIVE MAGNETIC FIELD WAVEFORM
DATASETS MEASURED IN LOCOMOTIVE CABS

DATA FILE NUMBER	APPENDIX	DATE AND TIME	SENSOR LOCATION SEE FIGURE 4-1		NUMBER OF SAMPLES	TRAIN AND CATENARY FREQUENCY
			STAFF	REF.		
TGV005	F	SEPT. 8 9:14-9:29	5	8	75	TEST TRAIN DC & 50 Hz
TGV006	G	SEPT. 8 9:30-9:42	5	8	25	TEST TRAIN 50 Hz
TGV007	H	SEPT. 8 9:43-9:48	6	8	10	TEST TRAIN 50 Hz
TGV008	I	SEPT. 8 9:48-9:54	7	8	10	TEST TRAIN 50 Hz
TGV009	J	SEPT. 8 9:56-10:14	5	8	38	TEST TRAIN 50 Hz & DC
TGV025	Z	SEPT. 9 7:45-8:01	25	26	88	REVENUE TRAIN DC & 50 Hz
TGV026	AB	SEPT. 9 8:01-8:21	25	26	40	REVENUE TRAIN 50 Hz

the record, the train leaves the dc portion of the catenary and joins the 25 kV, 50 Hz powered main line system. The top frame of the figure shows the static and lower frequency field characteristics. The static component of the field is clearly the dominant component. A 50 Hz component appears when the train enters the region having ac catenary power and the static field decreases. It is similar in character to the fields measured in the coaches arising from current in the catenary and track (Figures 3-5 and 3-6). Examination of the bottom frame provides more detail of the time varying field characteristics because the static field has been suppressed and the scales adjusted accordingly. The 50 Hz magnetic field component and its odd harmonics appeared as the dominant feature of the field when entering the high speed line.

Data presented in Figure 4-2 represents the magnetic field conditions at one sample height above the floor. Similar data measured simultaneously at other heights above the floor (provided in Appendix F) provide information about the variability in

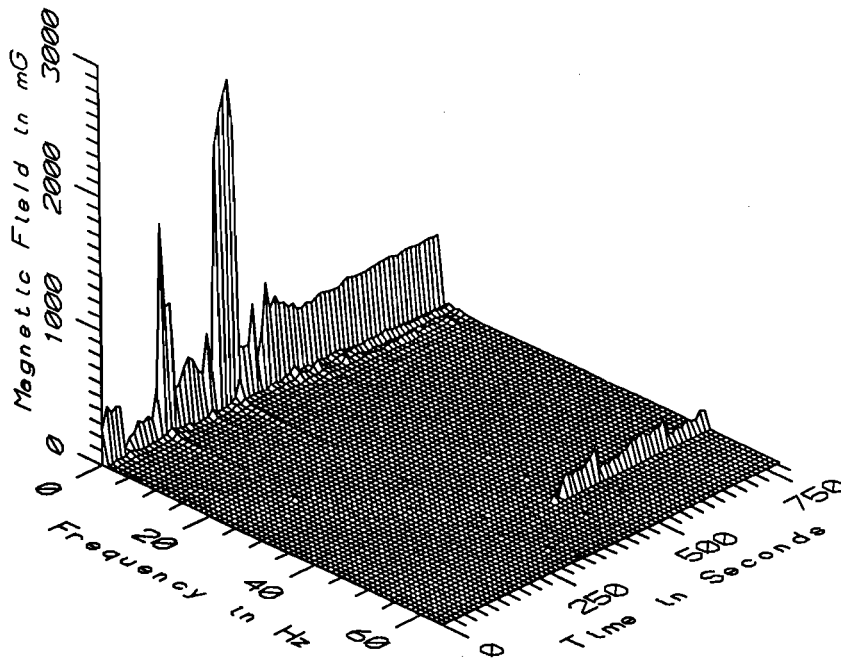

TGV005 - 110cm ABOVE FLOOR AGAINST ENGINEER'S CHAIR, PULL LOCOMOTIVE

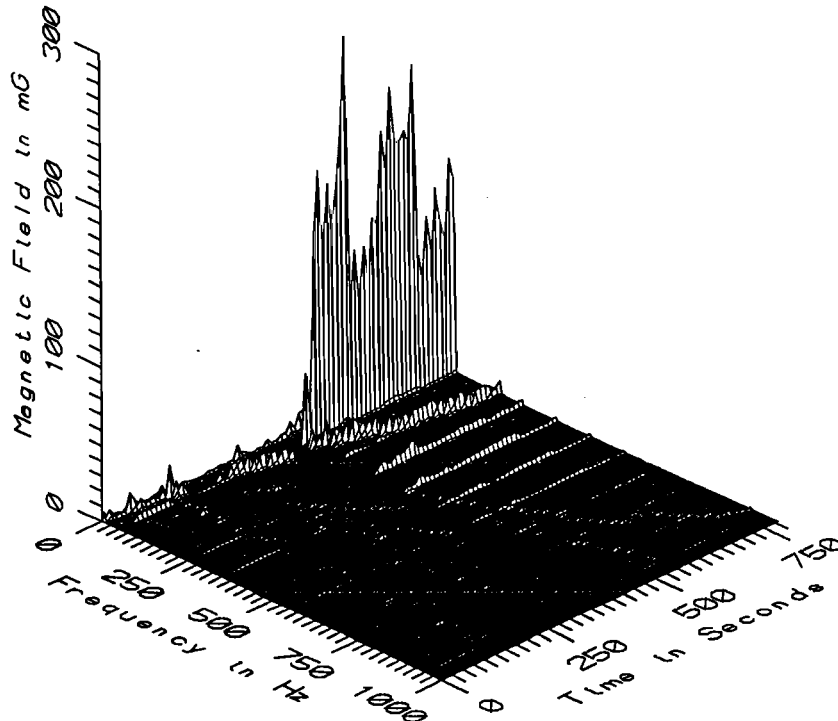

TGV005 - 110cm ABOVE FLOOR AGAINST ENGINEER'S CHAIR, PULL LOCOMOTIVE

FIGURE 4-2. MAGNETIC FIELD LEVEL BY TIME AND FREQUENCY AT A POINT NEAR THE ENGINEER IN THE CAB OF A TGV-A TRAIN AS IT DEPARTS ST. PIERRE-DES-CORPS ENROUTE TO PARIS. THE STATIC FIELD COMPONENT IS SUPPRESSED IN THE LOWER FRAME

magnetic field with height above the floor. Figures 4-3 and 4-4 show the magnetic field levels at the right rear corner of the engineer's seat as a function of height above the floor and time in four frequency bands. The static magnetic fields shown in the top frame of Figure 4-3 are highly variable in amplitude while the train is running on the dc catenary (0-400 seconds), but there is no consistent variability with height above the floor. Similarly, when the train is running on the 50 Hz catenary (beyond the 400 second point), the magnetic field in the power frequency band (50-60 Hz) shown in the top frame of Figure 4-4 is relatively uniform at the four measurement heights but variable over time in response to the train's power requirements.

Lateral profile measurements made around the engineer's seat (Appendices H and I) show that the power frequency magnetic field is spatially uniform from side to side, but there is a strong consistent spatial gradient in the axial direction. Figure 4-5 shows representative data from Appendix I. Data from the 10 cm, 60 cm, and 110 cm sensor locations show a modest but consistent reduction in magnetic field level with increasing distance from equipment in the machinery section of the locomotive consistent with the existence of a field source in that area. The elevated field levels at the point 160 cm forward of the rear bulkhead of the cab may be due in part to field perturbation by the ferromagnetic properties of the steel train body and operator's console. That sensor was in a tight recess between the locomotive's windshield and the steel instrument console. The magnetic field at the 160 cm sensor location does not appear to arise from a localized source in the console because it is temporally correlated with the power frequency magnetic field at other locations. These observations support the conclusion that the principal source of magnetic field in the engineer's cab is current in the catenary and track circuit, perhaps augmented fields from current in the portion of that circuit passing through the locomotive (25 kV, 50 Hz cabling, circuit breaker, transformer connections, and bonding conductors to the trucks).

Examination of the lower frames of Figures 4-3 and 4-5 reveals that there are other components of the magnetic field environment in the locomotive cab which are not spatially uniform and therefore probably originate from onboard sources. The field gradient indicated in those cited graphs suggests a source beneath the floor of the cab.

A smaller magnetic field component of variable frequency is also seen to run through the lower frame of Figure 4-2. This component, which starts at a very low frequency at time zero and grows in frequency as the train gains speed to approximately 200 Hz at the end of the graph (780 seconds), is apparently related to variable frequency current produced by the onboard inverters and delivered to the synchronous traction motors. Small magnetic fields at the odd harmonics of this variable frequency magnetic field are also

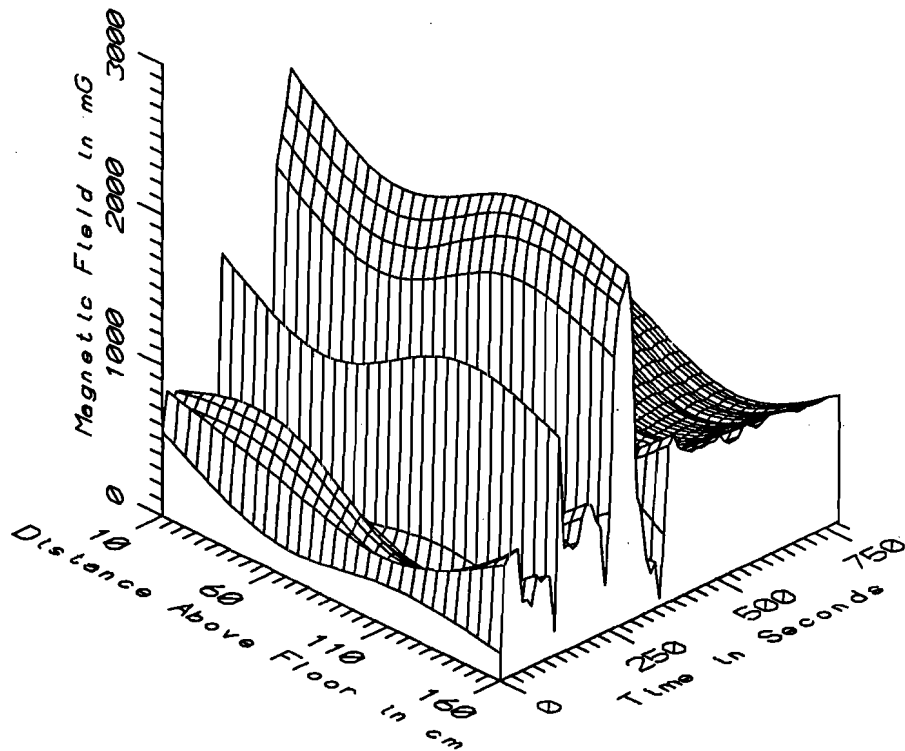

TGV005 - AGAINST ENGINEER'S CHAIR, PULL LOCOMOTIVE - STATIC

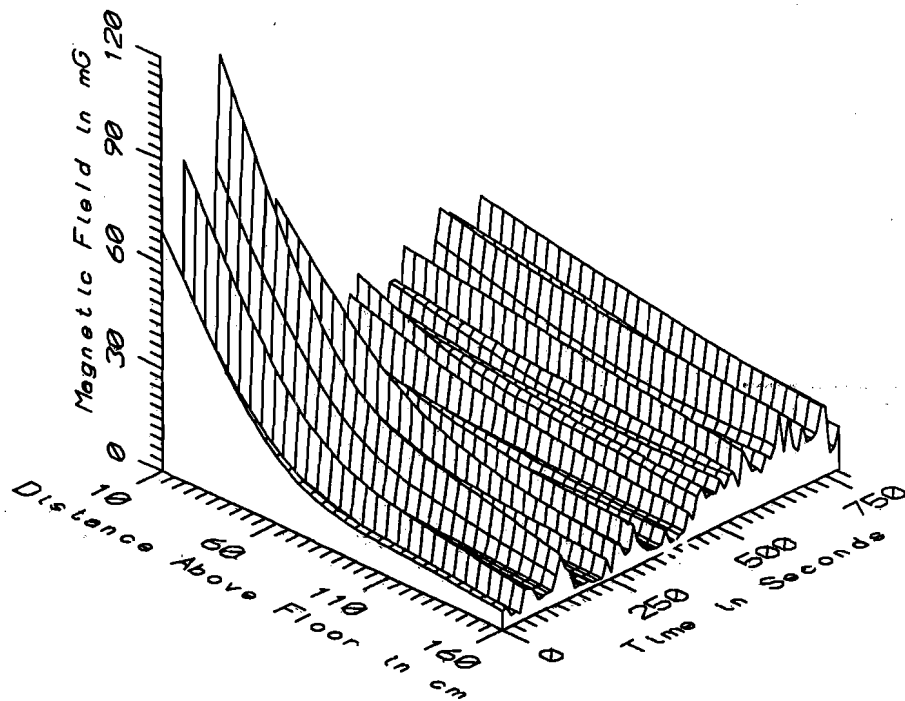

TGV005 - AGAINST ENGINEER'S CHAIR, PULL LOCOMOTIVE - LOW FREQ, 5-45Hz

FIGURE 4-3. MAGNETIC FIELD LEVELS VERSUS HEIGHT ABOVE THE FLOOR OVER TIME FOR STATIC FIELDS AND FIELDS IN THE LOW FREQUENCY (5-45 Hz) BAND, AT A POINT NEAR THE ENGINEER'S RIGHT SHOULDER

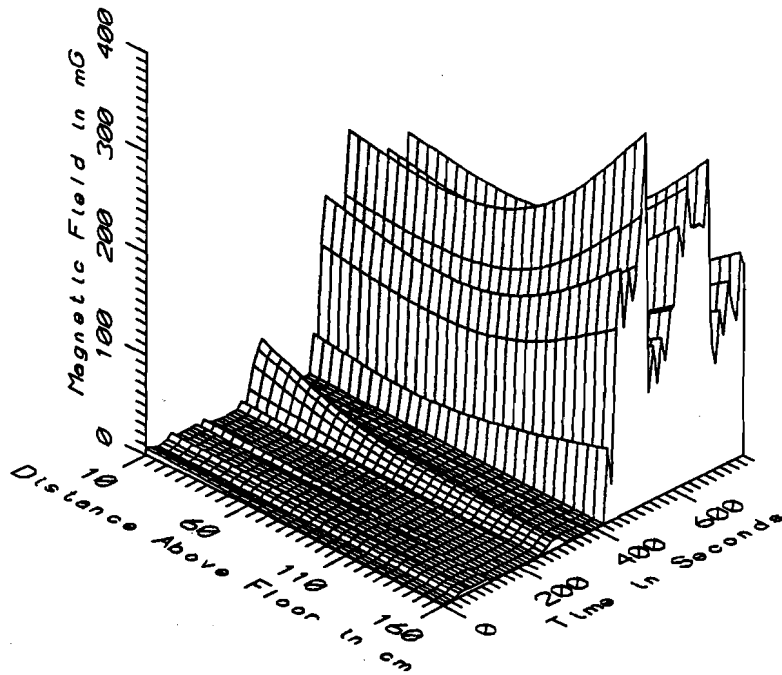

TGV005 - AGAINST ENGINEER'S CHAIR, PULL LOCO. - POWER FREQ, 50-60Hz

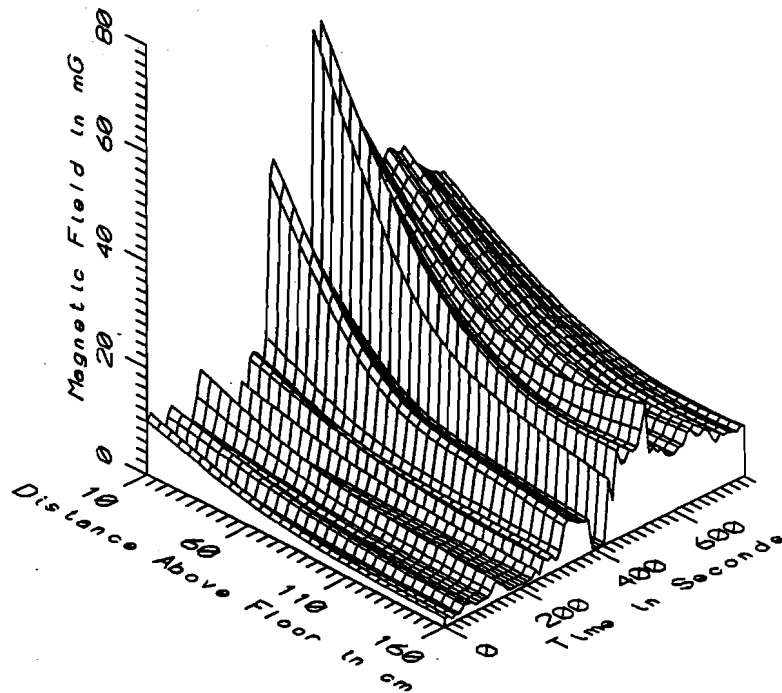

TGV005 - AGAINST ENGINEER'S CHAIR, PULL LOCO. - POWER HARM, 65-300Hz

FIGURE 4-4. MAGNETIC FIELD LEVELS VERSUS HEIGHT ABOVE THE FLOOR OVER TIME FOR FIELDS IN THE POWER FREQUENCY (50-60 Hz) AND POWER HARMONIC (65-300 Hz) BANDS, AT A POINT NEAR THE ENGINEER'S RIGHT SHOULDER

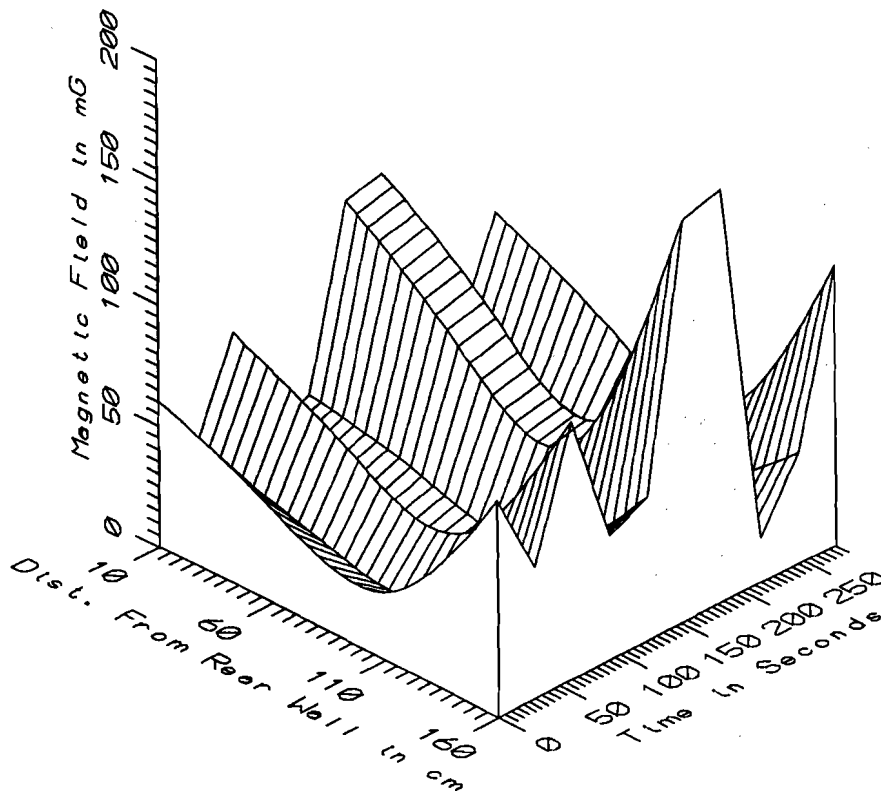

TGV008 - LONG. PROFILE FROM REAR WALL, PULL LOCO. - POWER FREQ, 50-60Hz

FIGURE 4-5. MAGNETIC FIELD LEVEL 1.3 m (4.3 ft) ABOVE THE FLOOR VERSUS DISTANCE FORWARD OF THE CAB'S REAR BULKHEAD OVER TIME, FOR FIELDS IN THE POWER FREQUENCY (50-60 Hz) BAND ALONG THE CENTERLINE OF THE LOCOMOTIVE

present in the cab. From the data available, one cannot determine with certainty whether the magnetic field component originates from the current in the inverters, traction motors and interconnecting wiring or whether it arises from "ripple" current in other onboard wiring. Examination of the field by frequency and time graphs at other heights above the floor (Appendix F) shows that the variable frequency magnetic field was much stronger near the floor of the locomotive and it is a component of the magnetic field which accounts for the spatial gradient of the magnetic field in the low frequency and power harmonic frequency sub-bands shown in the bottom frames of Figures 4-3 and 4-4, respectively. This gradient field shifts from the low frequency field sub-band (lower frame of Figure 4-3) to the higher power harmonic frequency band (lower

frame of Figure 4-4) in the time period from 200 to 300 seconds because the train is accelerating and the frequency of this field component increases accordingly. The passage of this variable frequency component through the power frequency band (top frame of Figure 4-4) is not apparent because this modest component is dominated by similar frequency magnetic fields from the catenary and track power circuit.

Since data from lateral profile measurements around the engineer's seat (Appendices H and I) show no significant variability in the magnitude of the variable frequency component of the magnetic field, it appears that the source of that field component is beneath the coach floor. This same field component was also detected in the coaches, but became progressively weaker in measurements made in coaches more distant from the locomotive.

The third distinct magnetic field component detected in the locomotive cab was a high frequency field of approximately 2470 Hz which remained approximately constant in magnitude (typically 0.5 to 1.0 mG) over time and at various locations throughout the cab.

Figure 4-6 shows a field by frequency and time plot focusing on the frequency range above 2000 Hz for the same measurement reported in Figure 4-2 which clearly shows this high frequency field component. Although there was a weak spatial gradient indicating a higher field level near the rear bulkhead of the cab, the spatial distribution would be more accurately characterized as "approximately uniform". It is undetermined whether this field is associated with train communication and signaling or some other function. Its magnitude is apparently not temporally correlated with train power requirements or train speed. The field was not examined for amplitude or frequency modulation.

4.4 DAT WAVEFORM DATA

Continuous recordings of the magnetic field waveforms at a sensor sitting on the right side of the console in front of the assistant engineer's seat were obtained with the Digital Audio Tape Recorder (DAT) in the cabs of the TGV-A locomotives. The time and length of those recordings are provided in Table 4-2. These tapes were scanned for transient fields which might result from pantograph bounce on the catenary or the operation of the circuit breaker as was done for the recordings in the coaches described in Section 3.4. No significant transients were found.

The correlation between DAT recordings and waveform capture system recordings was demonstrated in Section 3.4 above and is not repeated here. However, the mean, maximum, and minimum rms values of the field recorded by the DAT were determined and are presented in Table 4-2.

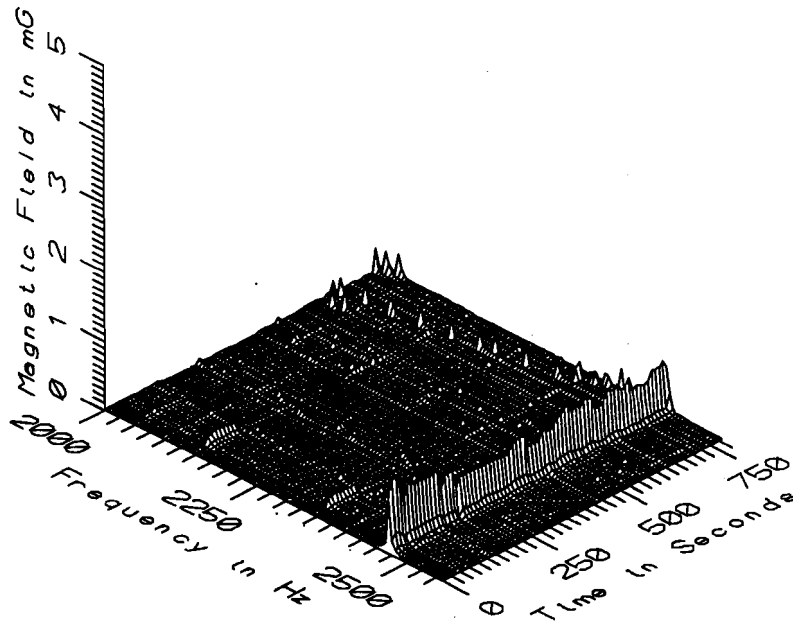

TGV005 - 110cm ABOVE FLOOR AGAINST ENGINEER'S CHAIR, PULL LOCOMOTIVE

FIGURE 4-6. MAGNETIC FIELD LEVEL BY TIME AND FREQUENCY AT A POINT NEAR THE ENGINEER IN THE CAB OF A TGV-A TRAIN SHOWING ONLY FIELD COMPONENTS IN THE 2000 TO 2560 Hz RANGE

TABLE 4-2.

SUMMARY OF TIME VARYING MAGNETIC FIELD LEVELS RECORDED ON THE CONSOLE IN FRONT OF THE ASSISTANT ENGINEER'S SEAT IN THE CAB OF THE TGV-A WITH THE DIGITAL AUDIO TAPE RECORDER (DAT)

TRAIN (DATASETS)	MEASUREMENT LOCATION		MAGNETIC FIELD MILLIGAUSS, RMS		
	FIGURE #	LOCATION	MINIMUM	AVERAGE	MAXIMUM
TEST TRAIN - DC PORTION (1-2)	4-1	8	1.8 mG	10.6 mG	132.04 mG
TEST TRAIN - AC PORTION (1-2)	4-1	8	5.4 mG	63.0 mG	206.8 mG
REVENUE SVC.- AC PORTION (3-2)	4-1	26	10.7 mG	41.4 mG	100.0 mG

4.5 RMS RECORDER DATA

RMS recorders were worn by two members of the test team during the trip in the test locomotive cab from St. Pierre-des-Corps to Paris and in the cab of the locomotive in normally scheduled revenue service from Paris to Vendome.

The average, maximum, and minimum values of the magnetic fields recorded with the rms meters are reported in Table 4-3. Data are not tabulated for the dc portions of the route because of errors introduced by the frequency limitations of the instrument.

TABLE 4-3.

STATISTICAL SUMMARY OF MAGNETIC FIELDS MEASURED
IN LOCOMOTIVE CABS USING RMS RECORDERS*

SYSTEM	MINIMUM	AVERAGE	MAXIMUM
TEST TRAIN			
RMS RECORDER 1**	0.5 mG	77.3 mG	694.4 mG
RMS RECORDER 2	0.3 mG	71.0 mG	323.2 mG
COMBINED	0.3 mG	74.2 mG	694.4 mG
REVENUE SERVICE TRAIN			
RMS RECORDER 1	0.4 mG	32.5 mG	95.6 mG
RMS RECORDER 2	0.2 mG	26.6 mG	80.2 mG
COMBINED	0.2 mG	29.6 mG	95.6 mG

* Data are only shown for measurements while the train was on the 50 Hz catenary. The principal time varying field components while on the dc catenary are at frequencies outside the instrument's response band.

** This rms recorder was intentionally held next to pieces of electrical equipment in the machinery portion of the locomotive for brief periods of time, hence the data may not be representative of magnetic field levels within the cab.

4.6 SUMMARY OF MAGNETIC FIELD LEVELS

As discussed in Section 4.3 above, the magnetic field environment in the cab of the TGV-A is quite different when the train is operating on a 1500 V dc catenary system compared to when it is operating on a 25 kV, 50 Hz ac system. Therefore, the field levels during those conditions of operation are analyzed separately. Some data are also available with the locomotive auxiliary equipment operating, but while the train is stationary in the Montparnasse Station. Those data are presented as well.

4.6.1 Train Stationary

Nine repetitive waveform samples of the magnetic field levels at various heights above the floor at the engineer's right shoulder were measured in the cab of the normal revenue train while it was standing at the Montparnasse Station. Power is supplied to the train via a 1500 V dc catenary at this station. The results of those measurements are summarized in Table 4-4. These data indicate a modest increase in static field levels above normal geomagnetic levels (approximately 470 mG near the floor and some average static field reduction at the higher measurement locations). Time varying fields are low and distributed throughout the ELF frequency range.

4.6.2 Trains Operating on DC

When the train is operating on dc catenaries near the Montparnasse or St. Pierre-des-Corps Stations, the magnetic field levels increase above those found in the stationary train. Detailed information about field characteristics in the cab of the test train is found in Appendices F and J and is summarized in Table 4-5. Similar data for the cab of a train in normal revenue service are found in Appendix Z and summarized in Table 4-6. While both tables show similar patterns of spatial and frequency distribution of magnetic field levels, the levels are consistently larger in the cab of the test train.

4.6.3 Trains Operating on AC

The normal catenary system for the TGV-A is a 25 kV, 50 Hz ac catenary fed via autotransformers from a balanced 50 kV single phase system. Much more extensive data were collected while the trains were operating on the ac catenary system.

Five appendices (F through J) contain data measured in the cab of the test train while operating on ac catenaries. Statistical summaries for each dataset are contained in the appendices with the data. Magnetic field data for the vertical profile measurements next to the engineer's seat with the test train on ac catenaries from Appendices F, G, and J are pooled and summarized in Table 4-7. Similarly, data from the two vertical profiles in the revenue

TABLE 4-4.

STATISTICAL SUMMARY OF MAGNETIC FIELD LEVELS AT VARIOUS HEIGHTS ABOVE THE FLOOR AT THE RIGHT REAR CORNER OF THE ENGINEER'S SEAT WHILE THE TRAIN IS AT REST

TGV025 - TRAIN AT REST		TOTAL OF 9 SAMPLES				
FREQUENCY BAND	HEIGHT ABOVE FLOOR (cm)	MINIMUM MAGNETIC FIELD (mG)	MAXIMUM MAGNETIC FIELD (mG)	AVERAGE MAGNETIC FIELD (mG)	STANDARD DEVIATION (mG)	COEFFICIENT OF VARIATION (%)
STATIC	10	510.16	640.58	616.86	41.45	6.72
	110	349.86	870.29	439.48	176.57	40.18
	160	170.00	477.30	414.41	98.99	23.89
5-45Hz LOW FREQ	10	0.43	4.03	1.53	1.25	81.47
	110	0.28	1.74	1.08	0.53	48.89
	160	0.33	2.09	1.14	0.56	49.22
50-60Hz PWR FREQ	10	0.79	1.21	1.05	0.12	11.37
	110	0.83	1.06	0.93	0.08	8.14
	160	0.85	1.12	0.97	0.10	10.18
65-300Hz PWR HARM	10	0.46	1.02	0.62	0.18	28.28
	110	0.43	1.07	0.62	0.19	30.20
	160	0.55	1.51	0.87	0.29	33.30
305-2560Hz HIGH FREQ	10	0.78	0.98	0.88	0.07	7.55
	110	0.71	0.87	0.79	0.06	8.06
	160	0.92	1.13	1.02	0.08	7.87
5-2560Hz ALL FREQ	10	1.45	4.42	2.27	1.00	44.03
	110	1.25	2.39	1.79	0.37	20.55
	160	1.48	2.78	2.06	0.43	20.69

TABLE 4-5.

STATISTICAL SUMMARY OF MAGNETIC FIELD LEVELS AT VARIOUS HEIGHTS ABOVE THE FLOOR AT THE RIGHT REAR CORNER OF THE ENGINEER'S SEAT IN THE TEST TRAIN WHILE OPERATING ON A 1500 V DC CATENARY

TGV005, TGV009 - TEST TRAIN - ALL DC SAMPLES		TOTAL OF 37 SAMPLES				
FREQUENCY BAND	HEIGHT ABOVE FLOOR (cm)	MINIMUM MAGNETIC FIELD (mG)	MAXIMUM MAGNETIC FIELD (mG)	AVERAGE MAGNETIC FIELD (mG)	STANDARD DEVIATION (mG)	COEFFICIENT OF VARIATION (%)
STATIC	10	307.50	2579.82	988.92	560.72	56.70
	60	187.79	2130.40	864.14	507.33	58.71
	110	37.21	2443.37	693.59	672.87	97.01
	160	157.74	2277.68	888.99	534.44	60.12
5-45Hz LOW FREQ	10	3.31	112.47	38.75	26.92	69.47
	60	1.97	41.95	14.14	9.31	65.86
	110	1.38	21.76	7.55	4.73	62.59
	160	1.17	13.60	5.51	3.24	58.88
50-60Hz PWR FREQ	10	1.05	59.39	9.43	15.00	159.06
	60	0.79	22.24	4.29	5.64	131.34
	110	0.61	12.95	2.91	3.28	112.59
	160	0.68	9.48	2.47	2.44	98.85
65-300Hz PWR HARM	10	0.68	14.77	6.33	4.45	70.39
	60	0.50	7.73	3.07	2.08	67.89
	110	0.47	4.80	1.85	1.17	63.53
	160	0.54	3.70	1.56	0.86	54.92
305-2560Hz HIGH FREQ	10	0.83	7.98	3.43	2.21	64.30
	60	0.78	4.62	2.08	1.15	55.27
	110	0.75	3.37	1.58	0.73	46.23
	160	0.92	3.00	1.67	0.58	35.00
5-2560Hz ALL FREQ	10	3.75	113.72	43.18	27.30	63.23
	60	2.36	42.90	16.02	9.96	62.16
	110	1.85	22.55	8.89	5.21	58.62
	160	1.88	15.34	6.78	3.64	53.64

TABLE 4-6.

STATISTICAL SUMMARY OF MAGNETIC FIELD LEVELS AT VARIOUS HEIGHTS ABOVE THE FLOOR AT THE RIGHT REAR CORNER OF THE ENGINEER'S SEAT IN A NORMAL REVENUE SERVICE TRAIN WHILE OPERATING ON A 1500 V DC CATENARY

TGV025 - DC SECTION ONLY		TOTAL OF 18 SAMPLES				
FREQUENCY BAND	HEIGHT ABOVE FLOOR (cm)	MINIMUM MAGNETIC FIELD (mG)	MAXIMUM MAGNETIC FIELD (mG)	AVERAGE MAGNETIC FIELD (mG)	STANDARD DEVIATION (mG)	COEFFICIENT OF VARIATION (%)
STATIC	10	290.71	2062.19	854.19	550.41	64.44
	60	89.56	1776.04	618.50	507.21	82.01
	110	228.62	1855.00	820.13	536.96	65.47
	160	106.94	1732.20	600.61	524.22	87.28
5-45Hz LOW FREQ	10	5.08	22.28	10.19	4.63	45.44
	60	3.42	15.55	7.74	3.59	46.39
	110	2.33	9.43	4.67	2.21	47.28
	160	1.73	8.52	4.26	2.11	49.59
50-60Hz PWR FREQ	10	0.80	2.91	1.41	0.49	34.89
	60	0.82	8.92	2.05	2.42	118.19
	110	0.63	1.37	1.00	0.21	21.17
	160	0.66	1.35	0.98	0.16	16.50
65-300Hz PWR HARM	10	1.05	3.14	1.56	0.50	32.21
	60	0.85	6.79	1.89	1.79	94.99
	110	0.65	1.61	1.08	0.26	23.76
	160	0.72	2.51	1.35	0.48	35.66
305-2560Hz HIGH FREQ	10	0.80	1.33	0.96	0.15	15.37
	60	0.76	2.76	1.09	0.60	54.98
	110	0.71	1.01	0.83	0.08	10.02
	160	0.91	1.46	1.05	0.14	13.57
5-2560Hz ALL FREQ	10	5.41	22.73	10.48	4.63	44.14
	60	3.79	19.10	8.43	4.47	52.98
	110	2.79	9.62	5.01	2.13	42.55
	160	2.80	8.94	4.77	1.98	41.40

TABLE 4-7.

STATISTICAL SUMMARY OF MAGNETIC FIELD LEVELS AT VARIOUS HEIGHTS ABOVE THE FLOOR AT THE RIGHT REAR CORNER OF THE ENGINEER'S SEAT IN THE CAB OF THE TEST TRAIN OPERATING ON A 25 kV, 50 Hz AC CATENARY

TGV005, TGV006, TGV009 - TEST TRAIN - ALL AC SAMPLES				TOTAL OF 83 SAMPLES		
FREQUENCY BAND	HEIGHT ABOVE FLOOR (cm)	MINIMUM MAGNETIC FIELD (mG)	MAXIMUM MAGNETIC FIELD (mG)	AVERAGE MAGNETIC FIELD (mG)	STANDARD DEVIATION (mG)	COEFFICIENT OF VARIATION (%)
STATIC	10	764.15	1080.08	889.35	83.87	9.43
	60	807.46	1149.41	922.28	90.53	9.82
	110	433.55	608.93	509.68	34.69	6.81
	160	738.38	939.28	857.81	44.32	5.17
5-45Hz LOW FREQ	10	8.13	50.15	23.70	8.64	36.47
	60	6.12	37.50	18.95	7.43	39.21
	110	5.18	32.27	15.68	6.33	40.34
	160	4.54	27.65	13.65	5.38	39.37
50-60Hz PWR FREQ	10	2.49	220.66	72.63	50.56	69.62
	60	1.91	210.75	68.30	48.94	71.66
	110	1.73	247.45	82.71	57.31	69.29
	160	1.62	366.56	125.48	86.02	68.55
65-300Hz PWR HARM	10	2.04	68.33	29.19	14.08	48.21
	60	2.07	33.85	17.12	6.78	39.59
	110	1.80	19.82	10.44	3.71	35.53
	160	1.79	22.67	9.62	3.41	35.46
305-2560Hz HIGH FREQ	10	1.33	10.51	5.34	1.96	36.77
	60	1.21	7.54	3.90	1.50	38.33
	110	0.99	8.07	3.56	1.57	44.05
	160	1.15	11.85	4.67	2.41	51.64
5-2560Hz ALL FREQ	10	20.05	227.36	85.74	46.82	54.61
	60	14.85	213.38	75.90	45.44	59.87
	110	11.11	248.67	87.00	54.54	62.70
	160	9.76	367.65	128.17	84.03	65.56

service train operating on ac catenaries (Appendices Z and AA) are pooled to create Table 4-8. Both tables show similar distribution of magnetic fields across frequency bands and measurement locations. Temporal variability as evidenced by the coefficient of variation of repetitive measurements over time is also similar between measurements in the two locomotives. Time varying magnetic fields at the 50 Hz power frequency and its harmonics are higher in the test train than in the revenue service train. The static field level and low frequency time varying magnetic field level (due primarily to variability in "static" field level) are somewhat higher in the test train, but the increase above the revenue train field levels is considerably less pronounced.

4.6.4 Effects of Passenger Load

Magnetic fields were measured in the cab of the train in normal revenue service to determine if passenger load would significantly affect traction power requirements and thereby affect magnetic field levels generated by current in the catenary and tracks or affect magnetic field levels generated by the locomotive and other onboard systems. The comparison is complicated somewhat by the fact that the test train consisted of two train sets coupled together, while the revenue service train was a single train set. Furthermore, the measurements were not made on identical runs; the test train traveled from St. Pierre-des-Corps to Paris while the revenue service train traveled from Paris to Vendome. However, the datasets are large enough that the concern about differences in runs are minimal.

The power frequency component of the magnetic field should be the component most closely correlated with motive power requirement. The average power frequency magnetic field for all four heights above the floor in the test train (from Table 4-7) is 87.3 mG, which is two and one third times larger than the 37.4 mG average across measurement heights in the revenue train (Table 4-8). Similar differences between field levels in the test train and revenue train were found in the DAT measurements (Table 4-2) and the rms recorder measurements (Table 4-3). Since the test train is a double train set, a twofold increase in magnetic field (two trains draw approximately twice the catenary current) would be expected. The actual increase was more than twofold. Hence, based on these tests, the mass of the passengers in the revenue service train does not lead to a detectable increase in magnetic field levels. In fact, after a 2:1 scaling to account for double versus single trains, the empty test train still produced larger power frequency magnetic fields in the cab than did the fully loaded revenue service train.

These results can be extrapolated to the power-frequency and harmonic components of the magnetic fields in the coaches as well. That is, field levels in a single train set might be expected to be roughly half those reported for the double train set test train in Section 3. When the trains are operating on the ac section of the

TABLE 4-8.

STATISTICAL SUMMARY OF MAGNETIC FIELD LEVELS AT VARIOUS HEIGHTS ABOVE THE FLOOR AT THE RIGHT REAR CORNER OF THE ENGINEER'S SEAT IN THE CAB OF A TRAIN IN NORMAL SCHEDULED REVENUE SERVICE OPERATING ON A 15 KV, 50 Hz AC CATENARY

TGV025, TGV026 - REVENUE TRAIN - ALL AC SAMPLES					TOTAL OF 95 SAMPLES	
FREQUENCY BAND	HEIGHT ABOVE FLOOR (cm)	MINIMUM MAGNETIC FIELD (mG)	MAXIMUM MAGNETIC FIELD (mG)	AVERAGE MAGNETIC FIELD (mG)	STANDARD DEVIATION (mG)	COEFFICIENT OF VARIATION (%)
STATIC	10	662.30	830.94	727.95	36.70	5.04
	60	486.44	668.90	555.72	36.82	6.63
	110	328.62	526.35	408.37	43.77	10.72
	160	673.14	897.41	752.17	50.73	6.75
5-45Hz LOW FREQ	10	4.17	54.50	24.40	8.68	35.57
	60	3.36	37.49	15.74	6.10	38.73
	110	3.55	33.90	13.53	5.55	41.04
	160	4.29	29.71	11.75	5.09	43.32
50-60Hz PWR FREQ	10	0.76	89.60	31.54	17.88	56.68
	60	0.41	70.05	25.59	14.03	54.84
	110	0.48	104.12	35.75	21.43	59.96
	160	0.58	159.82	56.59	36.13	63.83
65-300Hz PWR HARM	10	0.84	7.27	2.81	1.36	48.48
	60	0.47	5.81	2.08	0.91	43.85
	110	0.52	6.23	2.35	1.01	42.72
	160	0.73	9.23	3.19	1.61	50.48
305-2560Hz HIGH FREQ	10	0.73	3.74	1.84	0.58	31.65
	60	0.60	2.61	1.50	0.39	25.73
	110	0.59	3.48	1.84	0.52	28.16
	160	0.77	5.22	2.71	0.92	33.96
5-2560Hz ALL FREQ	10	14.34	94.73	42.25	14.52	34.37
	60	11.79	73.10	31.64	11.91	37.64
	110	11.55	105.80	39.74	19.51	49.11
	160	9.89	160.83	59.07	34.66	58.67

tracks the static field component and low frequency time varying magnetic field components appear to come from onboard sources; rather than the catenary-track circuit. Therefore, they should not be scaled by the number of connected train sets.

4.7 ELECTRIC FIELD SOURCES AND LEVELS

Ultra low frequency (ULF) and extreme low frequency (ELF) electric fields are effectively attenuated by conductive barriers such as the metallic bodies of locomotives. Consequently, significant electric fields from external sources associated with the railroad or the commercial power system were not expected to be present inside the locomotives. Lighting is powered by dc, hence it does not contribute to the time varying electric field.

Figure 4-7 shows the electric field as measured with the staff in position 5 (see Figure 4-1) at 170 cm above the floor. As the instrument does not measure static fields, what is shown at the very low frequencies is transient changes in the static field due to, for instance, motion of the researchers. There is a very small 50 Hz field present, less than 1 V/m, that is clearly due to the ac train power.

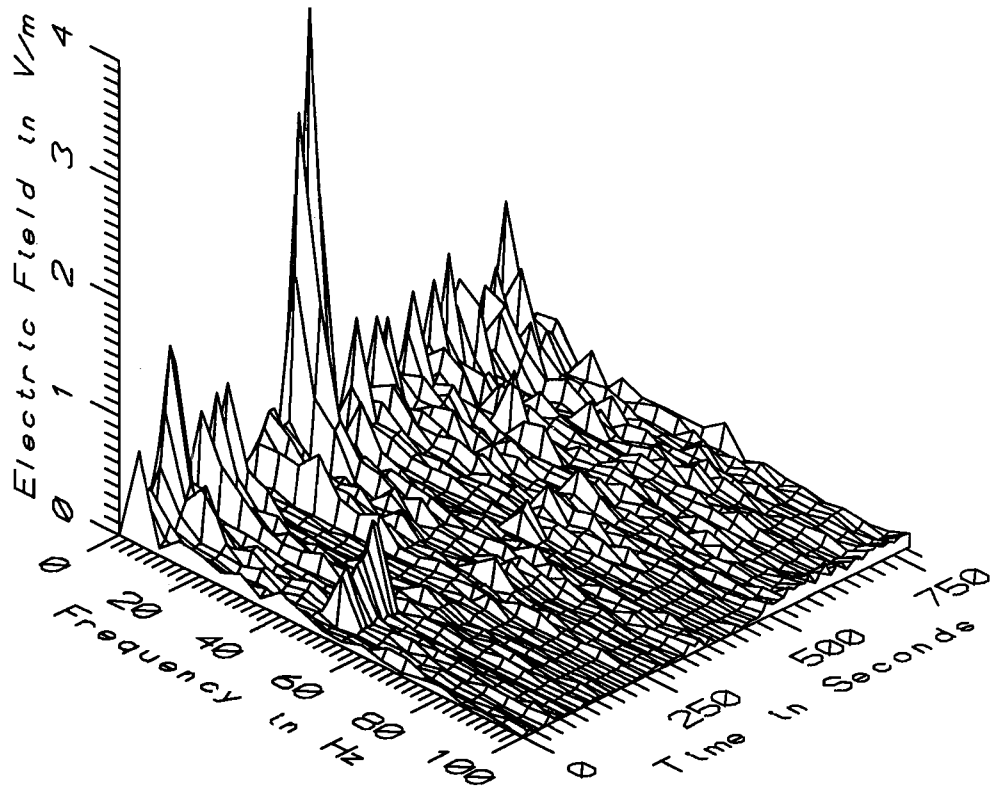

TGV005 - ELECTRIC FIELD IN TEST TRAIN LOCOMOTIVE

FIGURE 4-7. EXAMPLE OF ELECTRIC FIELD MEASURED IN THE LOCOMOTIVE AT STANDING HEAD POSITION BY THE ENGINEER'S SEAT

5. MEASUREMENTS ALONG THE WAYSIDE

Measurements along the wayside were conducted to determine the magnetic field in the vicinity of the TGV-A line. The data in this section show the contribution to the environmental field made by the TGV-A System and the attenuation of the field with distance away from the tracks.

5.1 MEASUREMENT LOCATIONS

Measurements were made at three different locations, exemplifying three distinctly different situations. All locations were along the TGV Atlantique line, that starts at the Montparnasse station in Paris. The three locations were an overpass at marker 121 km, an underpass at marker 105 km and at grade level in an open space along the track at marker 104 km.

Figure 5-1 is the schematic of the highway overpass at marker 121 km. The staff was over the catenary of the Paris bound train, on the sidewalk of the overpass. The staff was positioned vertically on the sidewalk, 1 meter from the steel guard rail of the overpass. The reference probe was located on the sidewalk, over the other track catenary. Measurements were taken on September 9, 1992 from 10:57 to 11:03 hours.

Figure 5-2 is the schematic of the highway underpass at marker 105 km. The staff was under the tracks of the Tours bound train, on the road next to the cement support structure of the train overpass. The reference probe was located at 10 cm above the road surface, under the other train track. The staff was in the vertical position. Measurements were taken on September 9, 1992 from 13:24 to 13:29 hours.

Figure 5-3 is the schematic of the measurement location in the at-grade open space along the track at marker 104 km. The staff was placed vertically at a distance of 7.5 m (24.6 ft) from the Paris bound track. The reference probe was located at a distance of 15 m (49.2 ft) from the staff, or 22.5 m (73.8 ft) from the track. Measurements were taken on September 9, 1992 from 14:14 to 14:32 hours.

5.2 REPETITIVE WAVEFORM DATASETS

The datasets that contain the information from the three locations described in Section 5.1 are TGV029, TGV030 and TGV031. Table 5-1 repeats the pertinent summary information about these datasets, shown previously in Table 2-1, including the number of samples and

HIGHWAY OVERPASS

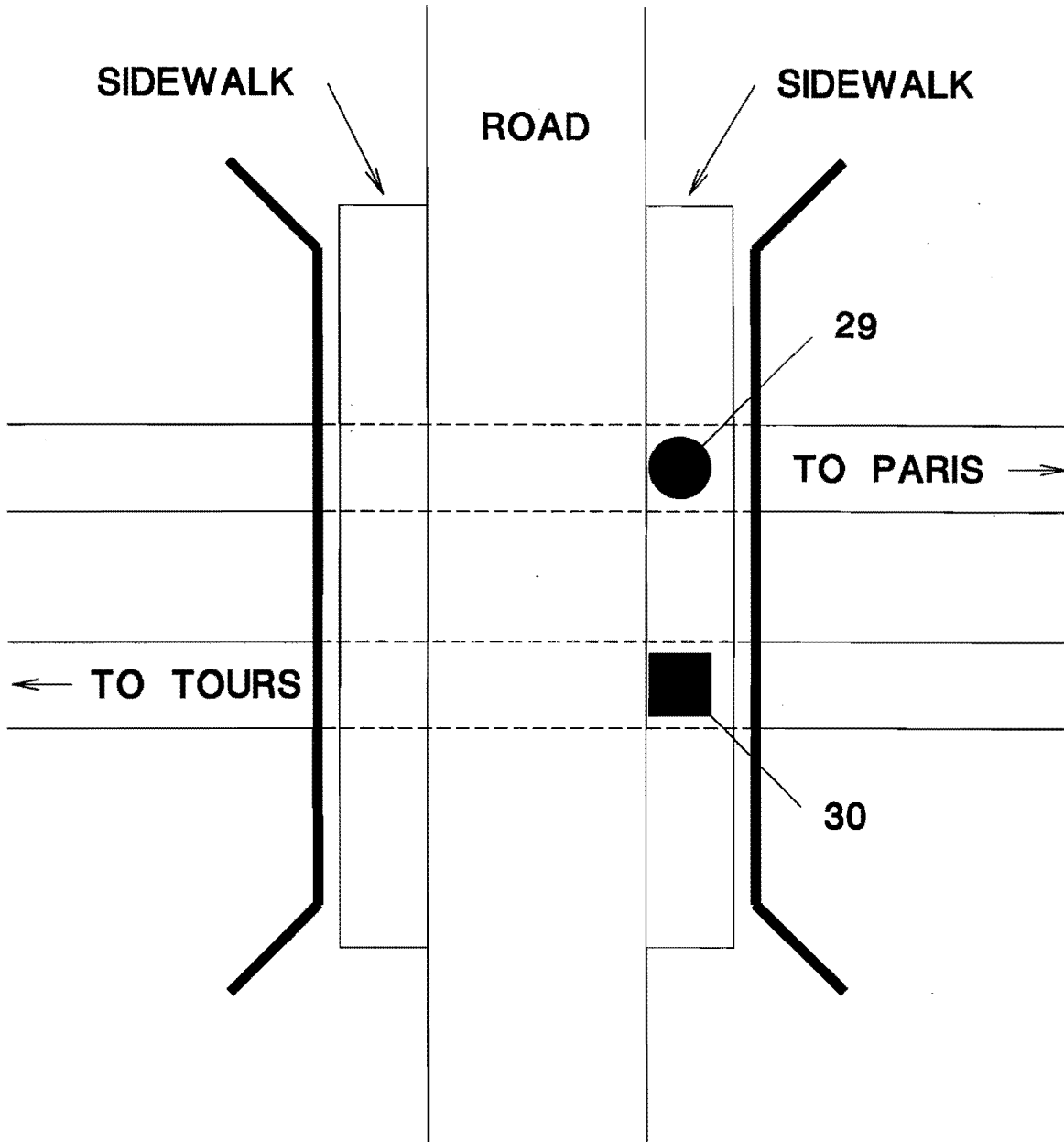
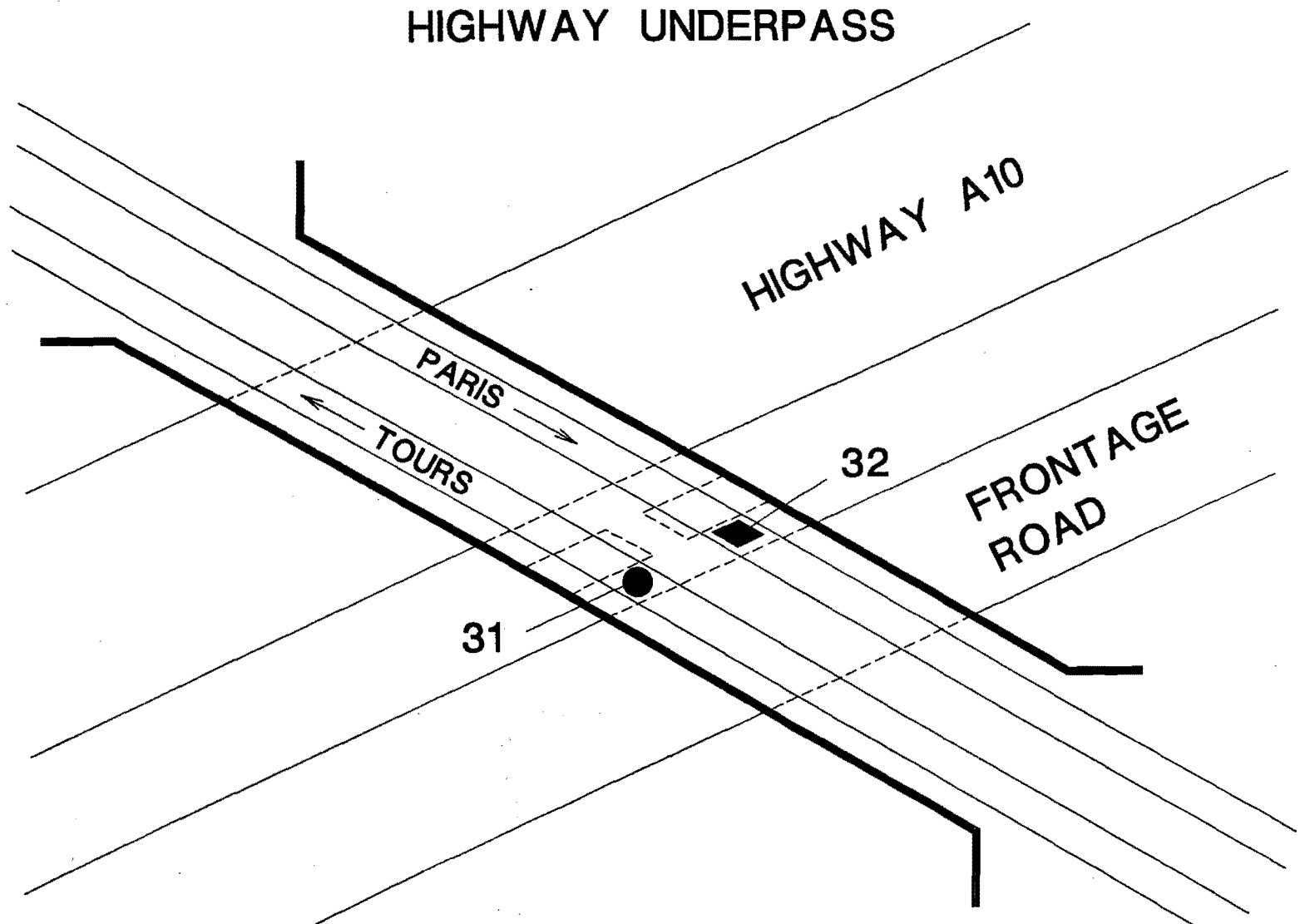

FIGURE 5-1. REPETITIVE WAVEFORM MEASUREMENT LOCATION ON THE HIGHWAY OVERPASS NEAR 121 km MARKER



5-3

FIGURE 5-2. REPETITIVE WAVEFORM MEASUREMENT LOCATION AT THE HIGHWAY UNDERPASS NEAR 105 km MARKER

Wayside Measurement at Marker 104km

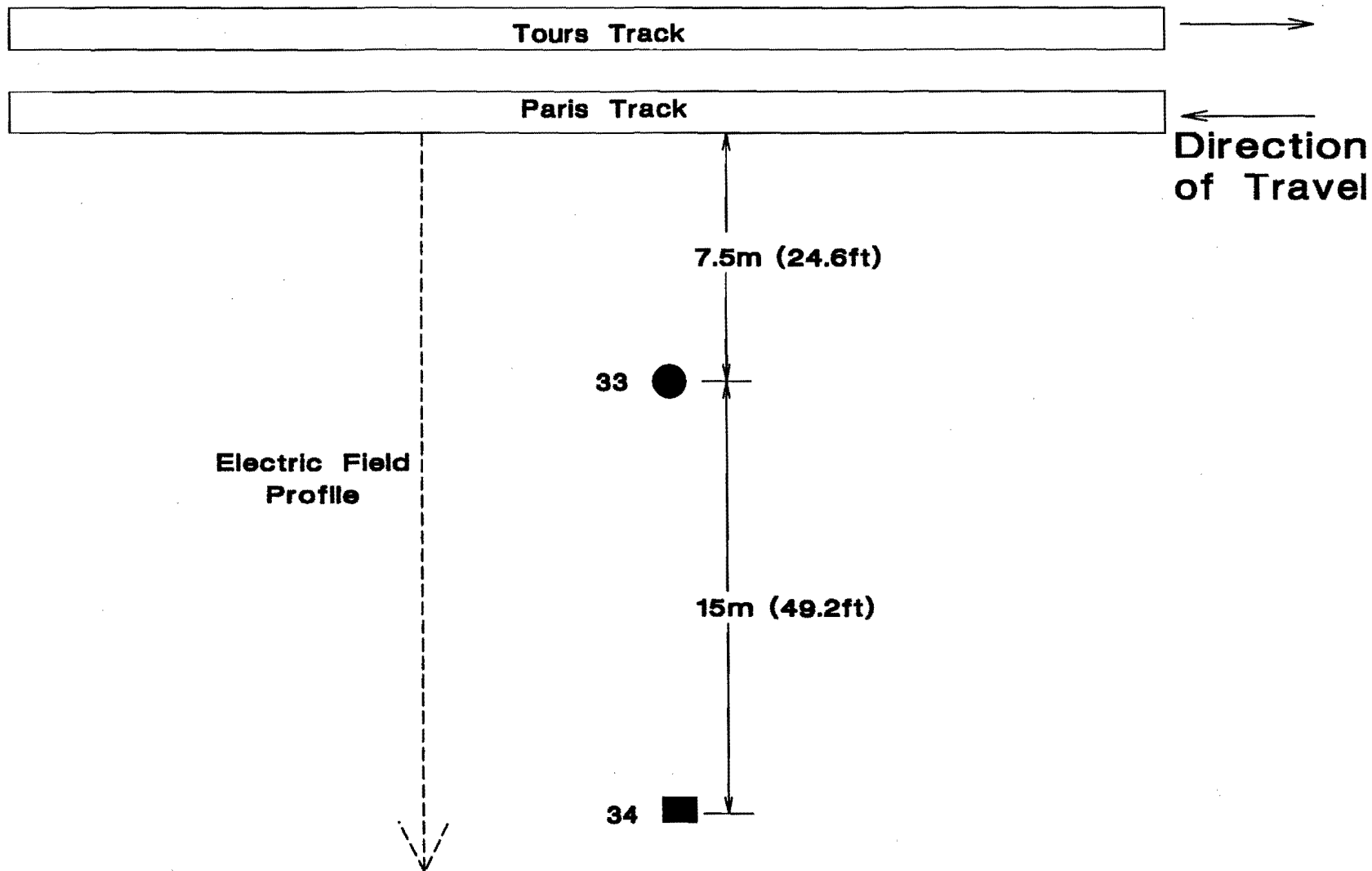

5-4

FIGURE 5-3. REPETITIVE WAVEFORM MEASUREMENT LOCATION AT AN OPEN SPACE ALONG THE WAYSIDE NEAR 104 km MARKER

the appendix number that has the complete set of data collected. TGV029 was taken at a sample interval of 5 seconds (12 per minute). The other two datasets were taken at sample intervals of 10 seconds (6 per minute).

A double train set passed by during the recordings at the overpass point. At the underpass site, a train set passed by starting at 100 seconds into the recording. Three trains went by at the open space site: the first from Paris starting at 130 seconds into the recording of data, the second from Paris starting at 440 seconds and the third to Paris starting at 710 seconds.

TABLE 5-1.

**REPETITIVE MAGNETIC FIELD WAVEFORM DATASETS
MEASURED ALONG THE WAYSIDE**

DATA FILE NUMBER	DATE/ TIME	LOCATION FIG. #	# OF SAMPLES & RATE	APPENDIX	REMARKS
TGV029	SEP. 9 10:57-11:03	5-1	33 5 SEC	AD	OVERPASS DOUBLE TRN
TGV030	SEP. 9 13:24-13:29	5-2	23 10 SEC	AE	UNDERPASS ONE TRAIN
TGV031	SEP. 9 14:14-14:32	5-3	83 10 SEC	AF	OPEN SPACE THREE TRNS

5.3 FIELD SOURCE IDENTIFICATION

There are several sources of magnetic fields along the wayside. The most common are the catenaries that carry the load, the adjacent feeder circuits that run on one side of the tracks and any nearby electric transmission or distribution lines.

5.3.1 At Overpass

Figure 5-4 is the three dimensional plot of dataset TGV029, for the 110 cm height probe. The plot is of the rms magnetic flux density in mG versus frequency in Hz and also versus time, in seconds. The 50 Hz component and its odd harmonics are clearly distinguishable for the time period that the train is in the vicinity. The first few harmonics, visible on the plot, are the third (150 Hz), the fifth (250 Hz), the seventh (350 Hz), the ninth (450 Hz) and the eleventh (550 Hz). The magnetic field peaks at approximately 270 mG as the train draws power from this section of track (between

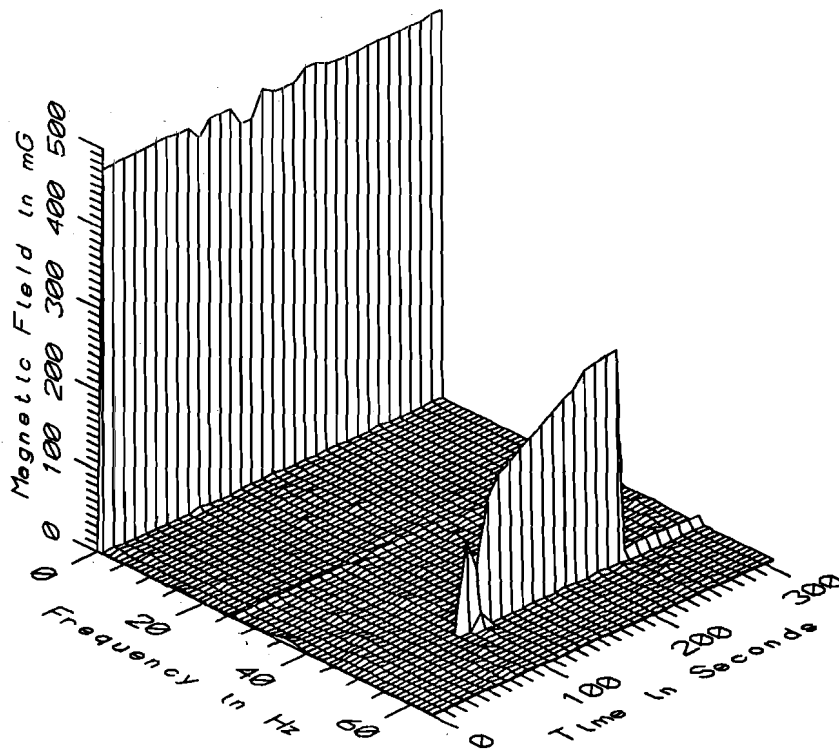

TGV029 - 110cm ABOVE OVERPASS BASE, ABOVE PARIS BOUND LINE. 120km MARKER

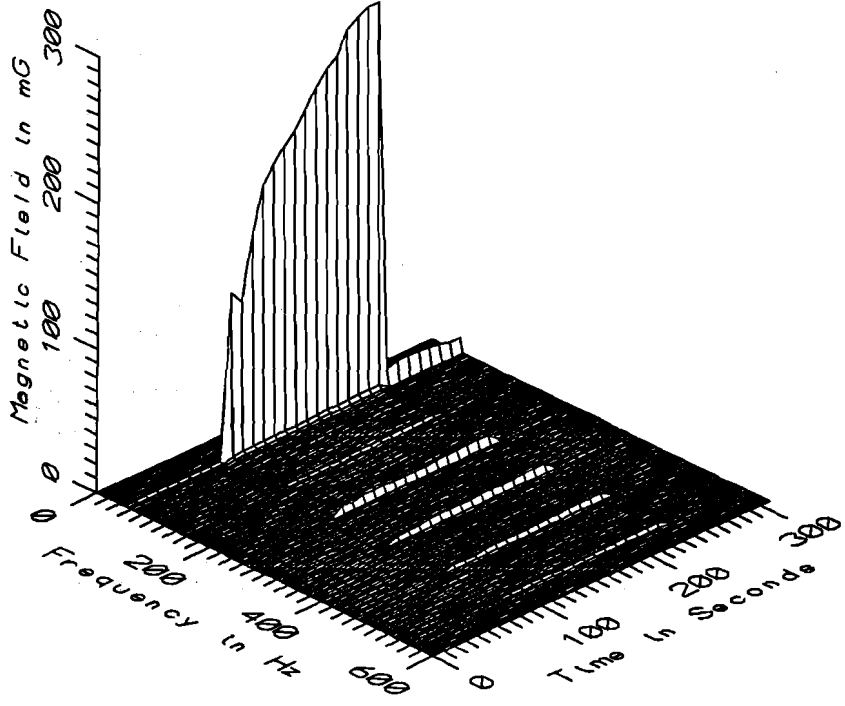

TGV029 - 110cm ABOVE OVERPASS BASE, ABOVE PARIS BOUND LINE. 120km MARKER

FIGURE 5-4. MAGNETIC FIELD LEVEL, WITH AND WITHOUT THE STATIC COMPONENT, AT 110 CM HEIGHT ABOVE THE SIDEWALK ON THE OVERPASS AS A FUNCTION OF FREQUENCY AND TIME

autotransformers) and then drops to about 10 mG as the train draws power from the next section. This occurs at approximately the 240 second time point of the plot. These plots indicate that the source of the 50 Hz field is probably the load in the catenary.

Comparing the fields measured by the 10 cm probe on the staff and the reference probe, the staff probe field is larger (See Appendix AD). This indicates that the train was closer to the staff probe, or that the train was Paris bound. The train stayed in the section between autotransformers from the 90 to the 240 second points, or for a total of 150 seconds. The structure of the electric supply system, shown schematically in Figure 5-5, indicates that the distance between the Chaillot and Les Arpents or Forgerie autotransformers is approximately 12 to 14 km. Since there is a phase break at the distant autotransformer stations, the TGV-A will coast for some distance after the phase break before reclosing the circuit breaker and drawing power from the catenary. The distance over which the train is drawing power might be 10 to 12 km. This means that the train speed can be calculated to be 240 to 288 km/h, which is a cross check for normal operating conditions.

The harmonics, although only 4.0% of the fundamental, follow the temporal variation of the 50 Hz fundamental. This is a further indication that the harmonics are also a function of the catenary current, or train load.

There is also a very small field, about 0.15 mG, at 15±5 Hz (measurement resolution). The amplitude of this field is relatively constant over the time period. Since the data is not affected by train load, the source is not related to the power consumption of the train. From the frequency, it is possibly due to a signalling system.

The magnetic field is stronger at the lowest sensor position on the staff (10 cm) which is closest to the catenary at the overpass and becomes weaker at higher sensor locations. A second order curve fit of the magnetic field attenuation between the 10 cm and the 160 cm probes suggests the center of the magnetic field loop source (the catenary with track return) is between 4.0 and 4.4 meters (13.1 to 14.4 ft) below the sidewalk of the overpass.

These data demonstrate that the main source of field is current in the catenary. That current and the resulting magnetic field is the highest when a train is present in the block between adjacent autotransformers.

5.3.2 At Underpass

Figure 5-6 is the three dimensional plot of dataset TGV030, for the 110 cm height probe. The plot is of the rms magnetic flux density in mG versus frequency in Hz and also versus time, in seconds,

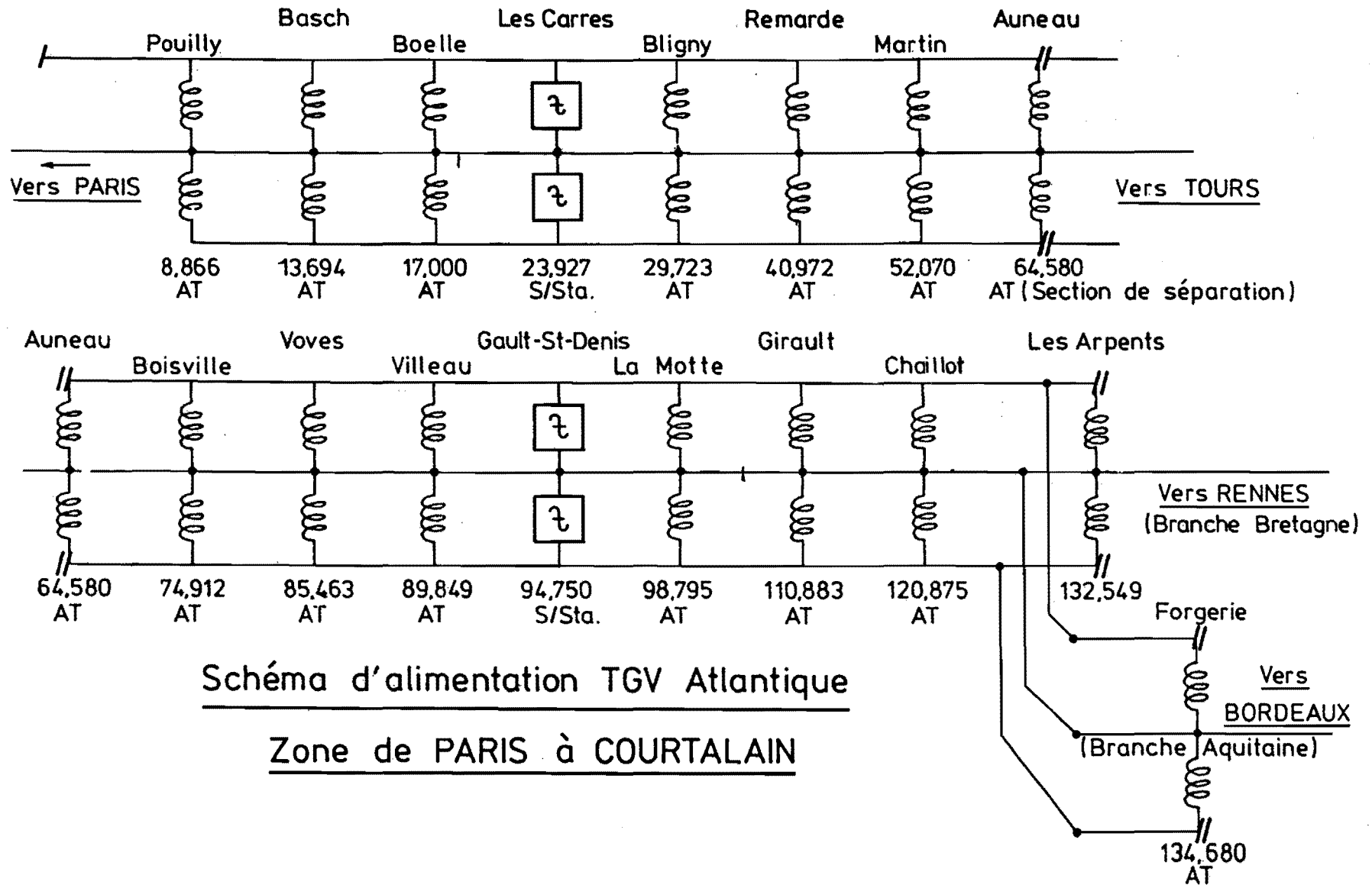
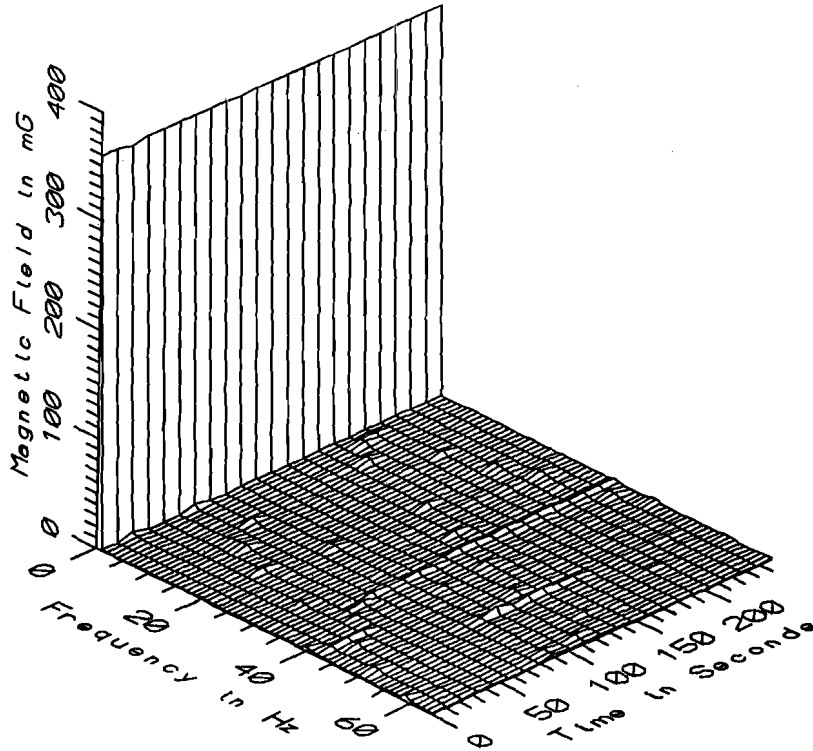
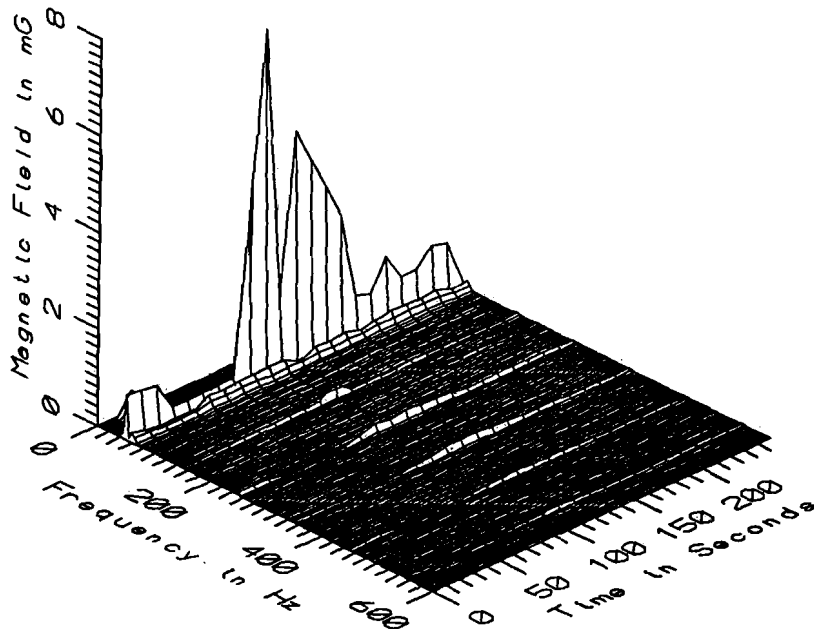

FIGURE 5-5. ELECTRIFICATION SCHEMATIC FOR THE AC POWERED SECTION OF THE TGV ATLANTIQUE LINE SHOWING THE LOCATION OF THE SUBSTATIONS AND THE AUTOTRANSFORMERS



TGV030 - 110cm ABOVE GROUND UNDER TOURS BOUND LINE AT UNDERPASS



TGV030 - 110cm ABOVE GROUND UNDER TOURS BOUND LINE AT UNDERPASS

FIGURE 5-6. MAGNETIC FIELD LEVEL, WITH AND WITHOUT THE STATIC COMPONENT, AT 110 cm HEIGHT ABOVE THE PAVEMENT AT THE HIGHWAY UNDERPASS AS A FUNCTION OF FREQUENCY AND TIME

which are the same axes as used in Figure 5-4. The 50 Hz component and its odd harmonics are clearly distinguishable for the time period that the train is in the vicinity. The first few harmonics, visible on the plot, are the third through the eleventh, as in the case of the overpass. The magnetic field peaks at approximately 7.2 mG as the train draws power from this section (between autotransformers) and is lower before the train arrives. The lower field is approximately 0.8 mG as the train draws power from another section. These plots indicate that the source of the 50 Hz field is again the load current in the catenary and return current in the tracks.

By comparing the field data of the 10 cm probe on the staff and the reference probe, we see that the staff probe field is larger (See Appendix AE). This indicates that the train was closer to the staff probe, or that the train was Tours bound. The train stayed in the section between autotransformers from the 80 to at least the 250 second points, or for a total of at least 170 seconds. The structure of the electric supply system, again referring to Figure 5-5, shows that the distance between the La Motte and Girault autotransformers is approximately 12 km. Thus, the train speed was calculated to be, at most, 254 km/h, which is in the normal operating range.

The harmonics, although only 5.2% of the fundamental, follow the temporal variation of the 50 Hz fundamental, to the extent that they can be measured, while the train is in the supply sector. This is a further indication that the harmonics are also a function of the catenary current, or train load.

Again, there is a very small field, about 0.14 mG, at 15±5 Hz (measurement resolution). The amplitude of this field is also relatively constant over the time period which is further confirmation that the source is not related to the power consumption of the train. From the frequency, it appears to be part of the signalling system.

The field at the underpass also changes with staff sensor height. Considering a second order curve fit of the attenuation between the 10 cm and the 160 cm probes yields a virtual source distance of 9.8 to 10.2 meters (32.1 to 33.4 ft). These are distances measured from the roadway pavement, and they appear reasonable, just by adding the estimated underpass clearance (5.5 m/18 ft), the thickness of the bridge members and ballast (2 m/6.6 ft) and half of the track-to-catenary height (2.5 m/8.2 ft). These calculations and the field plots indicate that the main source of field is current in the catenary and track return circuit while the train is in the block between adjacent autotransformers.

5.3.3 At Grade Open Space

Figure 5-7 is the three dimensional plot of field by frequency and time for dataset TGV031, for the 10 cm height probe. The 50 Hz component, and the odd harmonics to that fundamental, are clearly

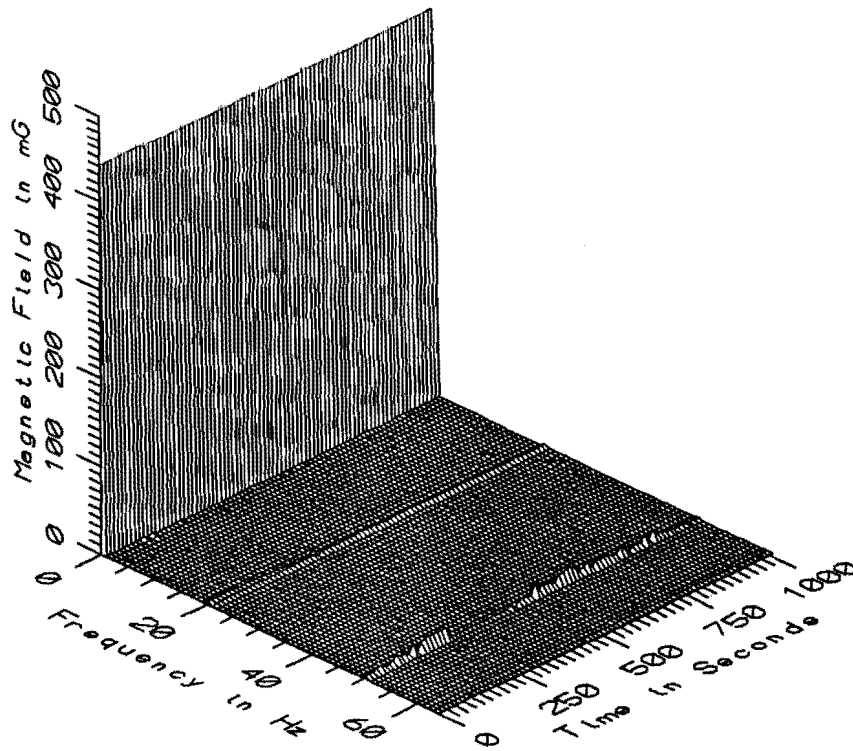

TGV031 - 10cm ABOVE GROUND 7.5m FROM PARIS BOUND LINE AT WAYSIDE

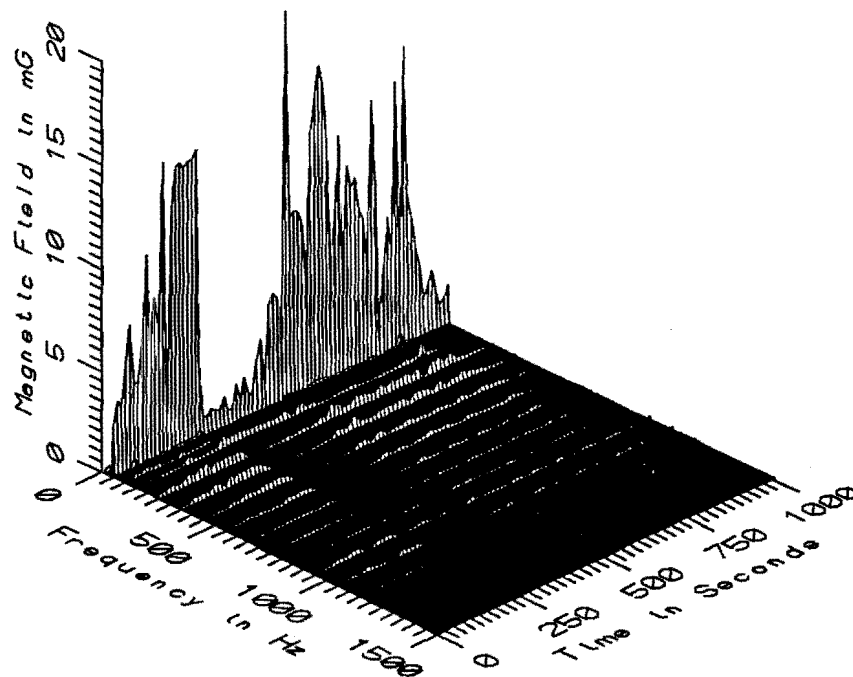

TGV031 - 10cm ABOVE GROUND 7.5m FROM PARIS BOUND LINE AT WAYSIDE

FIGURE 5-7. MAGNETIC FIELD LEVEL, WITH AND WITHOUT THE STATIC COMPONENT, AT 10 cm HEIGHT ABOVE THE GROUND, AT AN OPEN SPACE ALONG THE WAYSIDE NEAR 104 km MARKER, AS A FUNCTION OF FREQUENCY AND TIME

distinguishable for the time period that any of the three trains are in the vicinity. The first few harmonics, visible on the plot, are the third through the eleventh, as in the other two cases.

The first train was from Paris. Although it passed the measurement point at 130 seconds into the recording of data, its magnetic field signature is shown from 0 seconds to 250 seconds. The train stayed in this section between two autotransformers for a time period of 250 seconds. The structure of the electric supply system, Figure 5-5, shows that the distance between the La Motte and Girault autotransformers is approximately 12 km. This means that the train speed can be calculated to be 173 km/h, which is within normal operating range. The second train from Paris and the third to Paris exhibit similar patterns. These data suggest that the source of the field is the catenary and track return circuit as current flows to supply the power needed by the train.

A comparison of the field data of the 10 cm probe on the staff (Figure 5-7) and the reference probe (Figure 5-8) can be used to examine the attenuation rate of the magnetic field. These plots show clearly the correlation between the two probes. The field attenuation is discussed in Section 5.7.

The strength of the magnetic fields for the harmonics are 9.5% of the fundamental, and they follow the temporal variation of the 50 Hz fundamental while the trains are in the supply sector. This is a further indication that the harmonics are also a function of the catenary current, or train load.

Again, there is a very small field, about 1 mG, at 15 ± 5 Hz (measurement resolution). The amplitude of this field is relatively constant over the time period and not related to the power consumption of the train. It may be related to part of the signalling system.

The magnetic field is relatively uniform at various heights above the ground as demonstrated by the data in Appendix AF. That uniformity is expected because the field source appears to be balanced supply current in the catenary and return current in the tracks.

These data and the field plots further demonstrate that the main source of magnetic fields, in the vicinity of the railroad line, is the current in the catenary and track circuit while a train is in the traction power block between autotransformers.

5.4 DAT WAVEFORM DATA

Magnetic field data from the reference probe of the waveform capture system was recorded continuously with a Digital Audio Tape Recorder as described in Section 2.5.

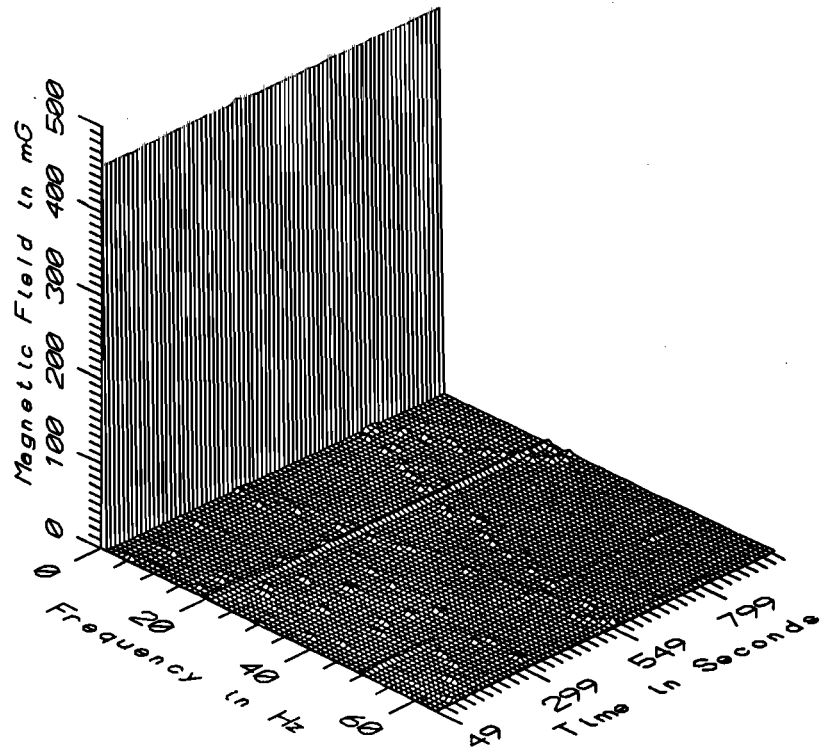

TGV031 - REFERENCE PROBE - 15m BEHIND STAFF AT WAYSIDE

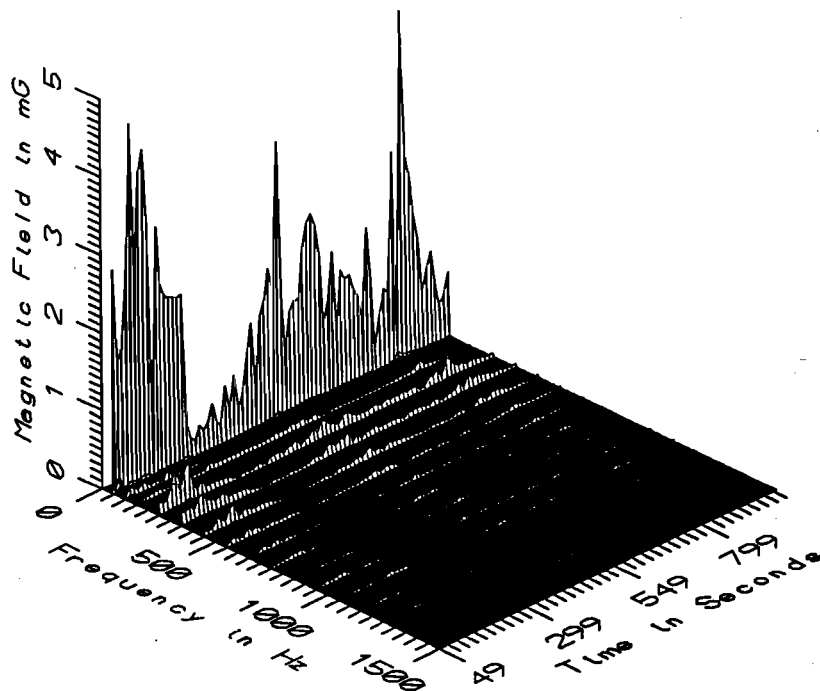

TGV031 - REFERENCE PROBE - 15m BEHIND STAFF AT WAYSIDE

FIGURE 5-8. MAGNETIC FIELD LEVEL, WITH AND WITHOUT THE STATIC COMPONENT, OF THE REFERENCE PROBE AT 10 cm HEIGHT ABOVE THE GROUND AND 15 m (49 ft) AWAY FROM THE STAFF, AT AN OPEN SPACE ALONG THE WAYSIDE NEAR 104 km MARKER, AS A FUNCTION OF FREQUENCY AND TIME

Figure 5-9 shows a representative sample of the magnetic field level measured with the DAT over time. These data were obtained at the reference probe location (Figure 5-3, Location Number 34) 22.5 m (73.8 ft) from centerline of the nearest track at an open area at the TGV-A track wayside. The recording time brackets the time of the repetitive waveform measurements made at the same location and reported in Figure 5-8. The similarity of the two figures demonstrates the consistency of these measurement procedures and shows that the periodic waveform sampling technique employed by the waveform capture system has not failed to detect significant field characteristics which occur on time spaces less than the five-second waveform sampling interval.

A statistical summary of rms magnetic field levels in the pass band of the DAT Recording System (0.1 Hz to 2.5 kHz) recorded at the wayside is presented in Table 5-2.

5.5 RMS RECORDING DATA

The difficulty in analyzing and interpreting rms recording data is that the researchers that carry them do not follow any particular path that would correspond to either passengers or railroad employees. Moreover, there is no detailed log that was kept for the explicit purpose of correlating rms recording data to a specific location, position or orientation.

In an attempt to gain a reasonable comparison, the rms recording data which was taken during the time period of dataset TGV031 has been examined. The rms recording data are shown in Figure 5-10. The data were measured in the general vicinity of the staff and reference probes, along the wayside in the open space. The researcher carrying the rms recorder wandered about in the general vicinity anywhere from next to the tracks to the reference probe location. The overall data have similar temporal characteristics to data from the waveform capture system shown in Figures 5-7 and 5-8 or as data from the DAT shown in Figure 5-9, however the amplitude characteristics are different. The first peak of the rms recording data is 29.4 mG at 14:17:18. The corresponding peak of the 110 cm probe of the TGV031 dataset, for the power frequency range, is 14.57 mG at 14:17:23, well within the resolution of the sampling interval of ten seconds. Similarly, the second peak of the rms recording is 26.0 mG at 14:23:09 and the corresponding repetitive waveform peak is 22.06 mG at 14:23:12. This second peak is also the maximum point recorded, as can be seen in Table 5-6. Because of the lack of precise information about the distance of the rms recorder wearer from the track, the rms recording data serve better as an indicator of general field values rather than precise data which can be used to estimate field attenuation or magnetic field levels at other distances from the tracks.

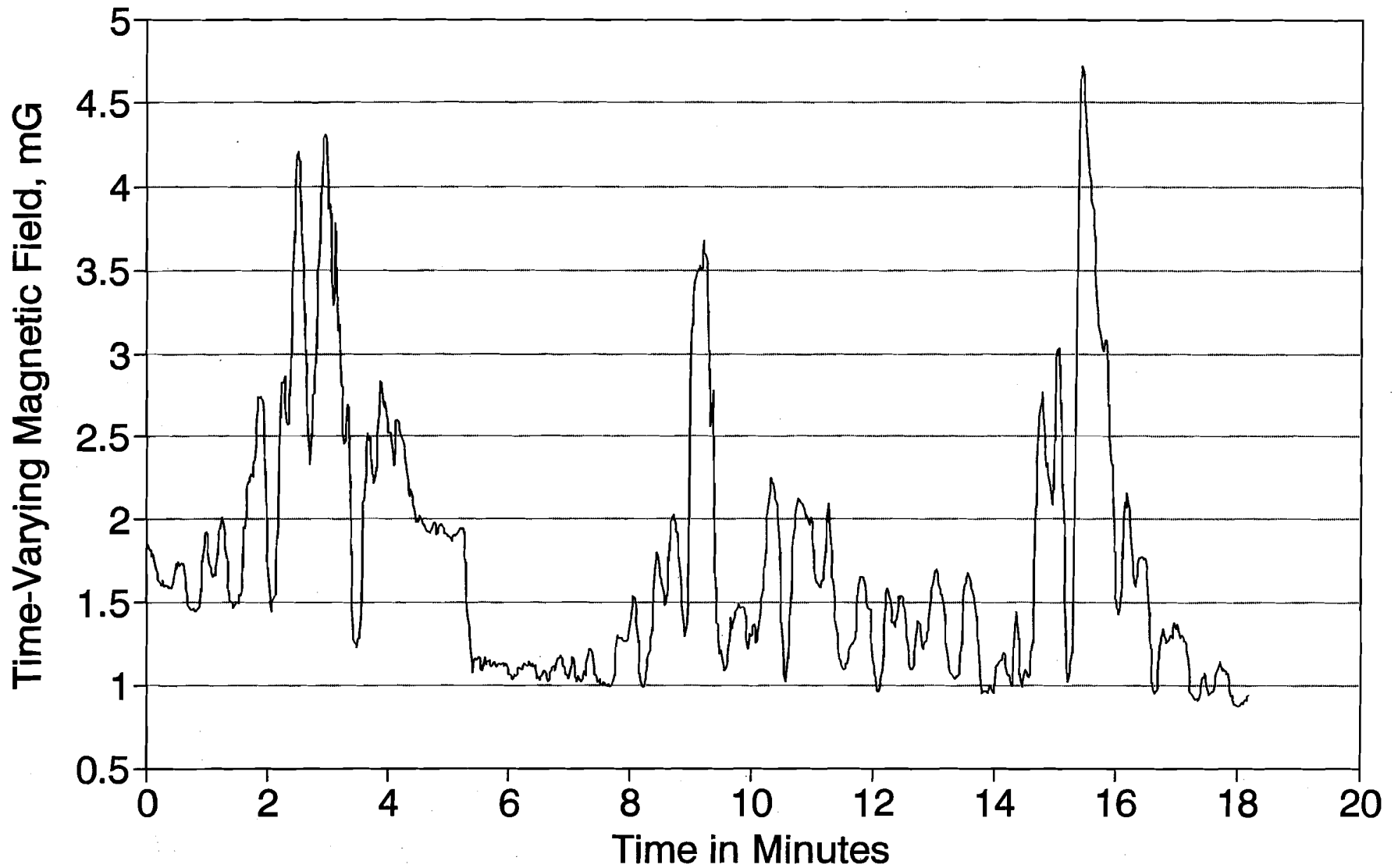
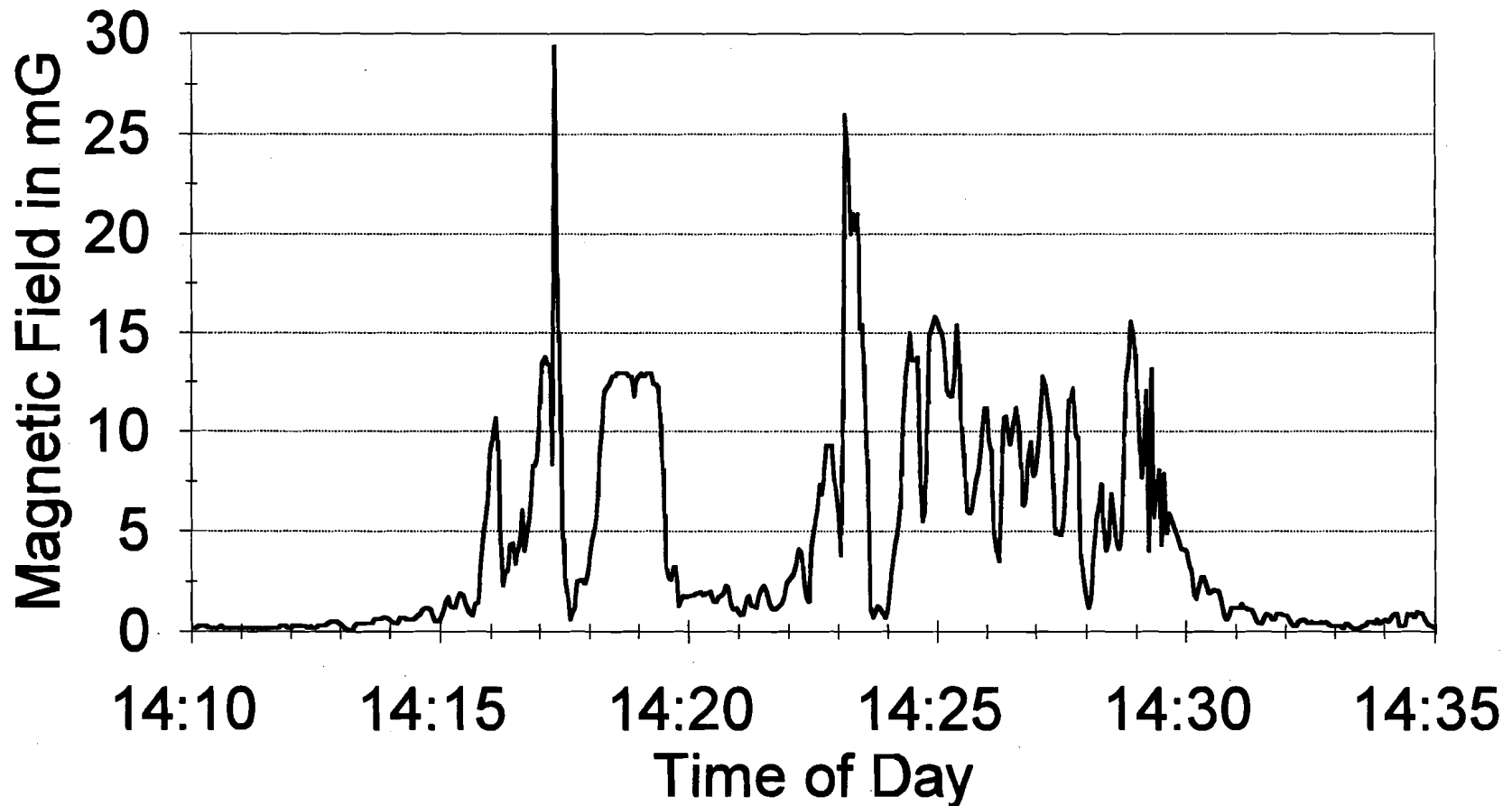

FIGURE 5-9. MAGNETIC FIELD LEVEL AS RECORDED BY THE DAT AT A POINT 22.5 m (74 ft) FROM CENTERLINE OF THE NEAREST TRACK, AS A FUNCTION OF TIME, AT AN OPEN SPACE ALONG THE WAYSIDE NEAR THE 104 km MARKER

WAYSIDE AT OPEN SPACE

EMDEX II Data From September 9, 1992



5-16

FIGURE 5-10. MAGNETIC FIELD LEVEL AS RECORDED USING AN RMS RECORDER, AT AN OPEN SPACE ALONG THE WAYSIDE NEAR 104 km MARKER, AS A FUNCTION OF TIME

TABLE 5-2.

**SUMMARY OF MAGNETIC FIELD LEVELS
RECORDED ALONG THE WAYSIDE WITH
THE DIGITAL AUDIO TAPE RECORDER (DAT)**

RAILROAD SECTION (DATASETS)	MEASUREMENT LOCATION		MAGNETIC FIELD MILLIGAUSS, RMS		
	FIGURE #	LOCATION	MINIMUM	AVERAGE	MAXIMUM
OVERPASS	5-1	30	9.8	88.6	720.1
UNDERPASS	5-2	32	4.7	8.4	62.0
WAYSIDE OPEN SPACE	5-3	34	0.9	1.7	4.7

The data of Table 5-3 contains the summary statistics for the rms recordings made while at the three locations: the overpass, the underpass, and the open space along the wayside. The summary shows the minimum, average, and maximum magnetic flux field levels, in mG.

5.6 SUMMARY OF MAGNETIC FIELD LEVELS

Magnetic fields along the wayside are a function of both the load of the nearby circuits and the distance from them. This section will discuss the statistical characteristics of the magnetic field level at the fixed measurement locations. The other major characteristic of the magnetic field at the wayside is attenuation, which will be discussed in Section 5.7.

Tables 5-4 through 5-6 present various summary statistics (minimum field level, maximum field level, average field level, standard deviation and coefficient of variation) for the repetitive waveform data in datasets TGV029, TGV030 and TGV031, respectively. The statistical parameters are provided for four measurement heights above the surface where the person was standing and for various frequency ranges. The ranges are for static magnetic fields, and for ac magnetic field sub-bands at low frequency (5-45 Hz), power frequency (50-60 Hz), power harmonic (65-300 Hz), and high frequency (305-2560 Hz) as well as the total time varying magnetic field in all frequency bands from 5 Hz to 2560 Hz. These tables demonstrate that the 50 Hz component of the magnetic field accounts for almost all of the ELF magnetic field at wayside locations.

TABLE 5-3.

**SUMMARY OF MAGNETIC FIELD LEVELS RECORDED
ALONG THE WAYSIDE OVERPASS, UNDERPASS, AND OPEN SPACE
USING THE RMS RECORDERS**

	MINIMUM	AVERAGE	MAXIMUM
OVERPASS SEP. 9, 1992			
RMS RECORDER #1 10:58:03-11:03:08	1.10	80.96	228.20
RMS RECORDER #2 10:58:03-11:03:09	0.10	50.92	206.40
COMBINATION	0.10	65.92	228.20
UNDERPASS SEP. 9, 1992			
RMS RECORDER #1 13:24:51-13:29:01	0.10	2.25	28.40
RMS RECORDER #2 13:24:51-13:29:03	0.10	1.88	18.00
COMBINATION	0.10	2.06	28.40
OPEN SPACE AT GRADE SEP. 9, 1992			
RMS RECORDER #1 14:10:00-14:35:00	0.20	13.03	56.00
RMS RECORDER #2 14:09:59-14:30:09	0.10	4.42	29.40
COMBINATION	0.10	9.19	56.00

TABLE 5-4.

SUMMARY STATISTICS OF VERTICAL DATASET MEASURED ON THE OVERPASS NEAR 121 km MARKER ABOVE PARIS BOUND LINE (DATASET TGV029)

TGV029 - OVERPASS - ABOVE PARIS BOUND LINE		TOTAL OF 33 SAMPLES				
FREQUENCY BAND	HEIGHT ABOVE GROUND (cm)	MINIMUM MAGNETIC FIELD (mG)	MAXIMUM MAGNETIC FIELD (mG)	AVERAGE MAGNETIC FIELD (mG)	STANDARD DEVIATION (mG)	COEFFICIENT OF VARIATION (%)
STATIC	10	514.32	524.46	518.84	3.58	0.69
	60	473.28	477.11	474.73	0.77	0.16
	110	451.67	487.83	476.38	7.90	1.66
	160	497.59	503.31	500.62	1.79	0.36
5-45Hz LOW FREQ	10	0.14	10.83	4.03	4.41	109.48
	60	0.15	8.05	2.86	3.08	107.50
	110	0.08	6.30	2.38	2.58	108.11
	160	0.18	5.96	2.29	2.38	103.97
50-60Hz PWR FREQ	10	1.30	466.97	165.39	186.07	112.51
	60	1.00	309.84	116.90	128.87	110.23
	110	0.82	267.83	98.16	108.20	110.23
	160	0.84	249.26	92.49	101.01	109.21
65-300Hz PWR HARM	10	0.19	13.52	4.92	5.27	107.15
	60	0.14	8.36	3.46	3.62	104.65
	110	0.13	7.74	2.94	3.03	103.18
	160	0.18	7.64	2.91	2.98	102.48
305-2560Hz HIGH FREQ	10	0.65	13.20	4.85	4.80	98.92
	60	0.47	8.17	3.44	3.31	96.19
	110	0.46	7.69	2.97	2.81	94.47
	160	0.48	7.60	3.00	2.80	93.35
5-2560Hz ALL FREQ	10	1.49	467.48	165.64	186.21	112.42
	60	1.14	310.14	117.08	128.96	110.15
	110	0.96	268.11	98.32	108.27	110.12
	160	1.01	249.54	92.66	101.08	109.08

TABLE 5-5.

SUMMARY STATISTICS OF VERTICAL DATASET MEASURED AT THE UNDERPASS NEAR 105 km MARKER UNDER PARIS BOUND LINE (DATASET TGV030)

TGV030 - UNDERPASS - UNDERNEATH PARIS BOUND LINE				TOTAL OF 23 SAMPLES		
FREQUENCY BAND	HEIGHT ABOVE GROUND (cm)	MINIMUM MAGNETIC FIELD (mG)	MAXIMUM MAGNETIC FIELD (mG)	AVERAGE MAGNETIC FIELD (mG)	STANDARD DEVIATION (mG)	COEFFICIENT OF VARIATION (%)
STATIC	10	295.28	298.45	297.43	0.57	0.19
	60	338.98	342.64	341.21	0.78	0.23
	110	355.99	359.75	358.91	0.83	0.23
	160	374.55	376.36	375.56	0.53	0.14
5-45Hz LOW FREQ	10	0.17	0.39	0.31	0.07	21.47
	60	0.17	0.21	0.18	0.01	5.67
	110	0.07	0.57	0.15	0.10	64.53
	160	0.18	0.25	0.20	0.02	9.41
50-60Hz PWR FREQ	10	0.18	6.20	1.42	1.53	107.76
	60	0.25	6.36	1.55	1.62	104.29
	110	0.23	7.19	1.68	1.79	106.10
	160	0.25	8.68	1.96	2.15	109.56
65-300Hz PWR HARM	10	0.04	0.27	0.09	0.05	61.59
	60	0.06	0.27	0.10	0.05	47.03
	110	0.10	0.35	0.18	0.05	28.55
	160	0.14	0.42	0.18	0.06	33.84
305-2560Hz HIGH FREQ	10	0.02	0.16	0.07	0.04	66.16
	60	0.02	0.16	0.07	0.04	62.00
	110	0.02	0.18	0.08	0.05	63.88
	160	0.02	0.23	0.09	0.06	67.16
5-2560Hz ALL FREQ	10	0.31	6.22	1.49	1.50	100.19
	60	0.32	6.37	1.58	1.60	101.43
	110	0.30	7.20	1.72	1.77	102.58
	160	0.35	8.69	2.00	2.13	106.22

TABLE 5-6.

SUMMARY STATISTICS OF VERTICAL DATASET MEASURED ALONG WAYSIDE NEAR 104 km MARKER
AT AN OPEN SPACE (DATASET TGV031)

TGV031 - OPEN SPACE - 7.5m FROM PARIS BOUND TRACK					TOTAL OF 83 SAMPLES	
FREQUENCY BAND	HEIGHT ABOVE GROUND (cm)	MINIMUM MAGNETIC FIELD (mG)	MAXIMUM MAGNETIC FIELD (mG)	AVERAGE MAGNETIC FIELD (mG)	STANDARD DEVIATION (mG)	COEFFICIENT OF VARIATION (%)
STATIC	10	438.36	442.84	441.64	0.55	0.12
	110	457.94	483.11	467.23	6.04	1.29
	160	465.74	472.07	469.41	1.36	0.29
5-45Hz LOW FREQ	10	0.12	1.11	0.33	0.14	42.87
	110	0.05	1.13	0.23	0.17	72.81
	160	0.17	1.08	0.30	0.14	48.20
50-60Hz PWR FREQ	10	0.67	18.82	6.37	4.66	73.21
	110	0.79	22.06	7.30	5.39	73.82
	160	0.86	23.98	7.85	5.85	74.60
65-300Hz PWR HARM	10	0.11	1.26	0.47	0.21	44.78
	110	0.18	1.34	0.57	0.23	39.65
	160	0.20	1.41	0.59	0.23	39.90
305-2560Hz HIGH FREQ	10	0.15	0.97	0.48	0.22	45.83
	110	0.18	1.04	0.55	0.25	45.31
	160	0.18	1.05	0.57	0.25	44.45
5-2560Hz ALL FREQ	10	0.82	18.88	6.43	4.64	72.16
	110	0.93	22.12	7.37	5.37	72.88
	160	1.01	24.04	7.92	5.83	73.66

As expected, both the largest maximum and largest average values occur in dataset TGV029, the overpass, at the 10 cm level, because that probe was closest to the catenaries. In all cases, the maximum coefficient of variation occurs in the power frequency range, which is a statistical indication that the main source of the field is the catenary and it has the greatest variability as the load varies with time.

5.7 ATENUATION OF MAGNETIC FIELDS

Magnetic fields decrease as the distance from the tracks is increased. The attenuation is described in terms of the point where the maximum or average values of the recorded magnetic field would diminish to 1 mG. The calculations are based on the measurements made at the open space along the wayside, or dataset TGV031, and represent the attenuation of the 50 Hz fundamental only.

The calculations proceed as follows. First, the statistics for the power frequencies are obtained for the two measurement points, the 10 cm probe on the staff (TGV031) and the reference probe. The 10 cm height on the staff was chosen because it is consistent with the 10 cm height of the reference probe and because the magnetic field level off to the side of the tracks is not strongly dependent on height above ground as was demonstrated in Table 5-6. Next, the values are curve fitted to a $1/d^2$ curve. This second order curve appears to be the best fit to the data and is also the theoretically expected fit. The curve fitted equations are then used to calculate the point at which the value of the field drops off to 1 mG.

Table 5-7 shows the point at which the value of the field attenuates to a 1 mG value. This is given as a distance from the track, in meters. Table 5-7 shows the attenuation of both the maximum and average fields and also for the three different field signatures produced by the three trains that passed during the test. The maximum values are obtained by considering the maximum points recorded and their time coincident maximum points at the reference location. The average values are in reality averages of all the magnetic field values while a train was in that portion of the circuit and does not include any quiescent points. Hence, it is more of an indication of the average field values while the train is within the block between adjacent autotransformer stations.

5.8 SUMMARY OF ELECTRIC FIELD LEVELS

Time varying electric field levels were measured perpendicular to the track at the open space along the wayside. Table 5-8 has the results of those measurements. Figure 5-11 shows the data taken

during these measurements plotted as a profile away from the tracks.

TABLE 5-7.

**CALCULATED DISTANCES FROM TRACK TO REACH
A 1 mG MAGNETIC FIELD MAXIMUM OR AVERAGE LEVEL
BASED ON CURVE FIT OF DATA FOR THREE DIFFERENT TRAIN PASSES
ALONG THE WAYSIDE OPEN SPACE**

	1st TRAIN	2nd TRAIN	3rd TRAIN
MAXIMUM	63 m (206.6 ft)	46 m (150.8 ft)	60 m (196.7 ft)
AVERAGE	40 m (131.2 ft)	28 m (91.8 ft)	31 m (101.6 ft)

TABLE 5-8.

**ELECTRIC FIELD MEASUREMENTS
ALONG A PERPENDICULAR PROFILE TO THE TRACKS
ALONG THE WAYSIDE AT AN OPEN SPACE**

DISTANCE FROM TRACK IN METERS	ELECTRIC FIELD IN V/m
7.5	385.0
10.0	175.0
12.5	66.8
15.0	25.4
20.0	3.0

ELECTRIC FIELD AT WAYSIDE

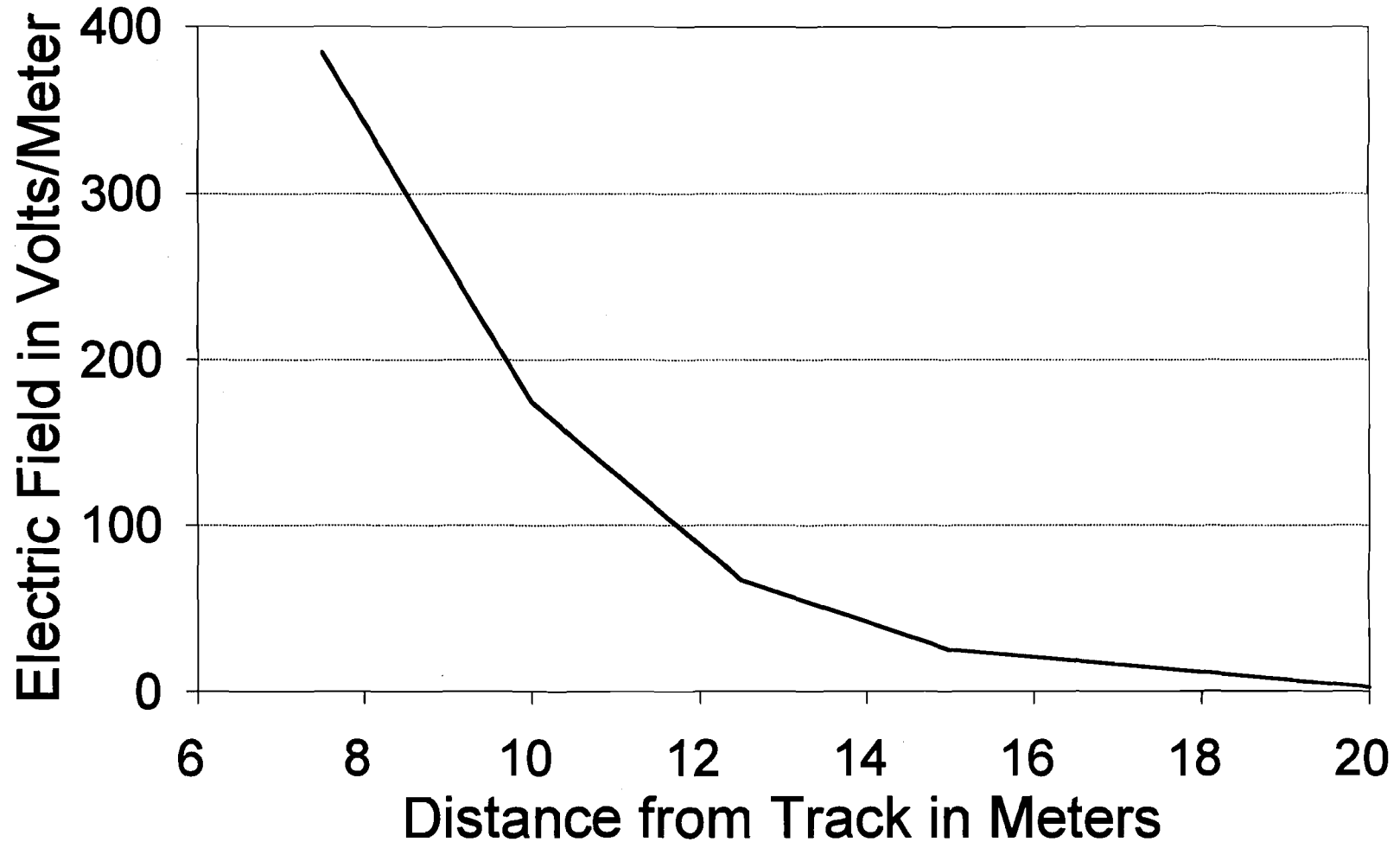

5-24

FIGURE 5-11. PROFILE OF ELECTRIC FIELD LEVEL AT AN OPEN SPACE ALONG THE WAYSIDE, AS A FUNCTION OF PERPENDICULAR DISTANCE FROM THE TRACKS

6. PASSENGER STATION MEASUREMENTS

6.1 MEASUREMENT LOCATIONS

Platform readings were taken at the Vendome Station. The station is at approximately the 162 km marker. Figure 6-1 shows the track arrangement at the station and the location of the magnetic field probes. There are four tracks between two platforms. The inside tracks are for high-speed, pass-through trains. The outside tracks are for local trains, the ones that stop at the station. The test TGV-A was parked at the far platform, away from the measurements. From Figure 6-2, the *Branche Aquitaine*, it can be seen that Vendome is approximately halfway between the autotransformers at *Le Bois* and *Barlette*.

The measurements were taken on the northern side of the tracks, closest to the Paris bound track. The staff with the four probes was set in a vertical position at the edge of the platform and the reference probe set on the platform 5 m (16.4 ft) from the staff in a direction away from the track. Data was also collected using the DAT and rms recorders. Three datasets were recorded on September 8, 1992 from 16:03 to 16:54, during three different train passes.

6.2 REPETITIVE WAVEFORM DATASETS

The three datasets that contain the information on the recorded magnetic fields are TGV017, TGV018 and TGV019. Table 6-1 contains the pertinent summary information about them, including the number of samples, the sampling time interval and the appendix containing all the data.

Recordings were timed to coincide with the passing of a train. The first two trains were single trains from Paris. The last train was a double train going to Paris.

6.3 FIELD SOURCE IDENTIFICATION

The main source of magnetic fields on a platform is the catenary/track and autotransformer primary (feeder) circuits. As such, the largest fields exist whenever a train is nearby and drawing current from the catenary and track circuit between autotransformers bracketing the station. Smaller magnetic fields occur when the train is outside the immediate block between the nearest autotransformers due to the autotransformer primary feeder current flowing past the station on the catenary and return feeder circuit and the sharing of catenary-track current by autotransformers other

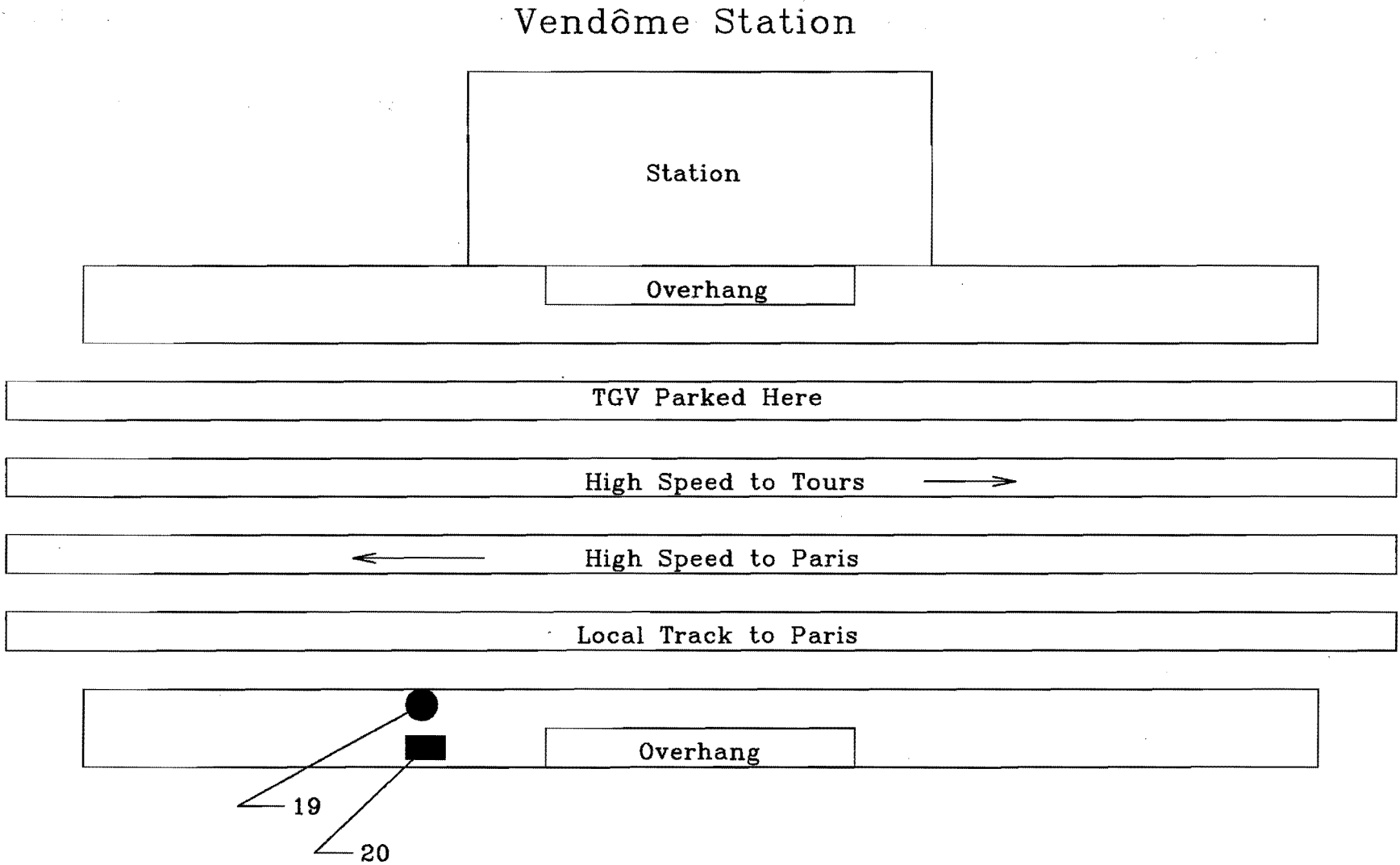
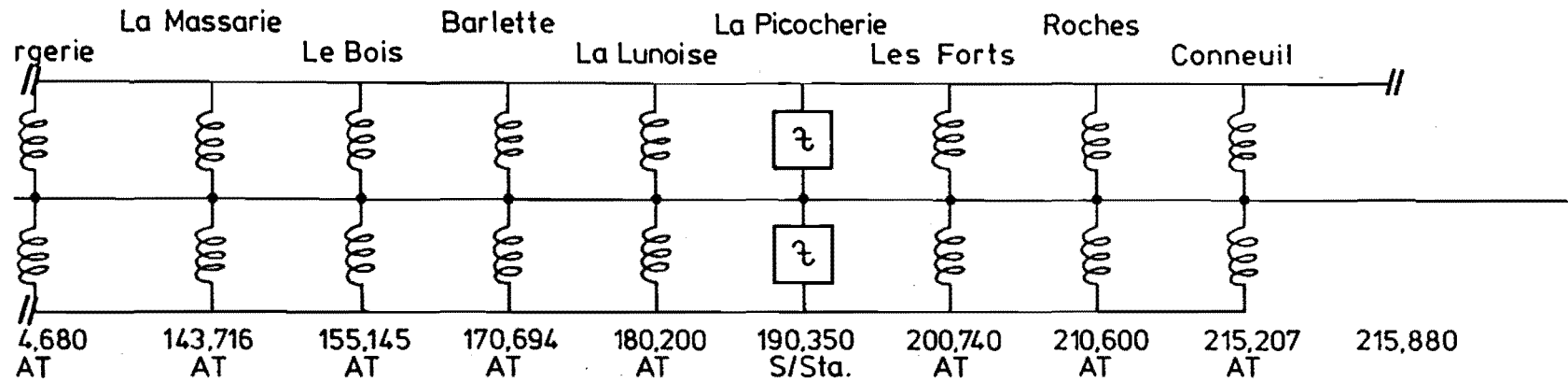
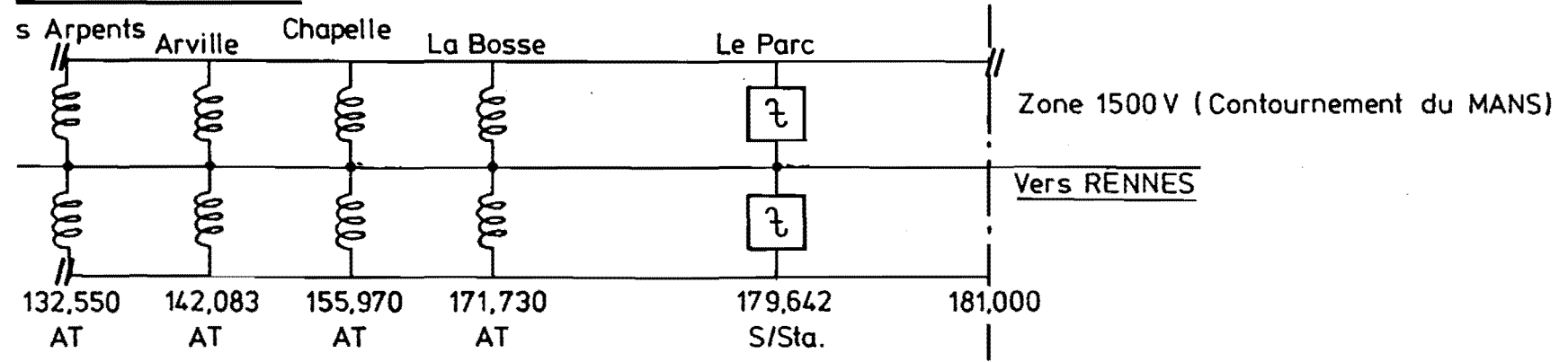

FIGURE 6-1. REPETITIVE WAVEFORM MEASUREMENT LOCATIONS ON THE PASSENGER PLATFORM AT VENDOME

BRANCHE AQUITAINE



BRANCHE BRETAGNE



6-3

Schéma d'alimentation TGV Atlantique : branche Aquitaine_branche Bretagne

FIGURE 6-2. ELECTRIFICATION SCHEMATIC FOR THE AC POWERED SECTION OF THE TGV ATLANTIQUE LINE SHOWING THE LOCATION OF THE SUBSTATIONS AND AUTOTRANSFORMERS

TABLE 6-1.

REPETITIVE MAGNETIC FIELD WAVEFORM
DATASETS MEASURED ON THE VENDOME PASSENGER PLATFORM

DATA FILE NUMBER	DATE/ TIME	LOCATION STAFF / REFERENCE	# OF SAMPLES & RATE	APPENDIX	REMARKS
TGV017	SEP. 8 16:03-16:05	19 / 20	13 5 SEC	R	SINGLE TR. FROM PARIS PASSES
TGV018	SEP. 8 16:34-16:45	19 / 20	73 5 SEC	S	SINGLE TR. FROM PARIS PASSES
TGV019	SEP. 8 16:50-16:54	19 / 20	25 5 SEC	T	DOUBLE TR. TO PARIS PASSES

than the ones at the end of the occupied power block. By far the largest fields were recorded at the third pass, which is the Paris bound train. It was on the high speed track closest to the measuring instruments and a double train set. Additional field sources contributing to background magnetic field levels between trains appear to be nearby electrical equipment and electric distribution lines.

Figure 6-3 is the plot of the rms magnetic flux density in mG versus frequency in Hz and also versus time in seconds for TGV017. The upper plot includes the static component. The bottom plot suppresses it so as to be able to identify the other frequencies.

The static component at the passenger platform at Vendome Station is approximately the normal unperturbed geomagnetic field and constant with respect to time throughout all the measurements. There is, however, a 25 mG difference between the probes at the two ends of the staff and the one at the 110 cm height, the end probes reading higher. This static field enhancement could be due to the existence of ferromagnetic material in the platform and the overhang above the platform. This enhancement and variation with height is consistent for all three measurements.

The plot of the rms magnetic flux density for the first train pass, Figure 6-3, shows clearly the 50 Hz component and its odd harmonics. The same holds true for the other two trains, TGV018 and TGV019 (Figures 6-4 and 6-5). Also, all three figures show a small field in the 12 Hz point. As mentioned in Section 5.3 of this report, both the value for the frequency and the constancy of

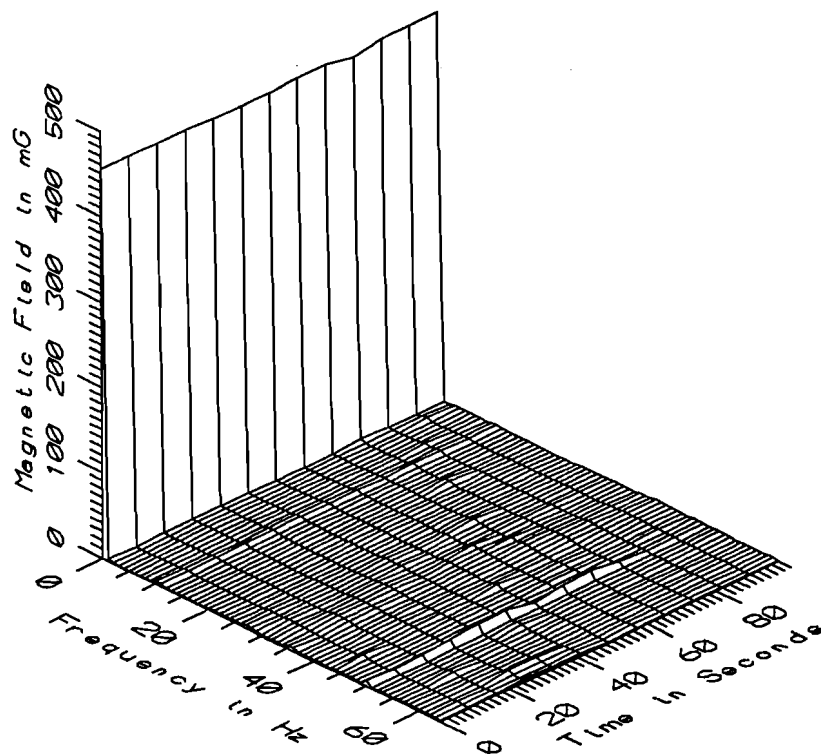

TGV017 - 110cm ABOVE FLOOR AT EDGE OF PLATFORM, VENDOME STATION.

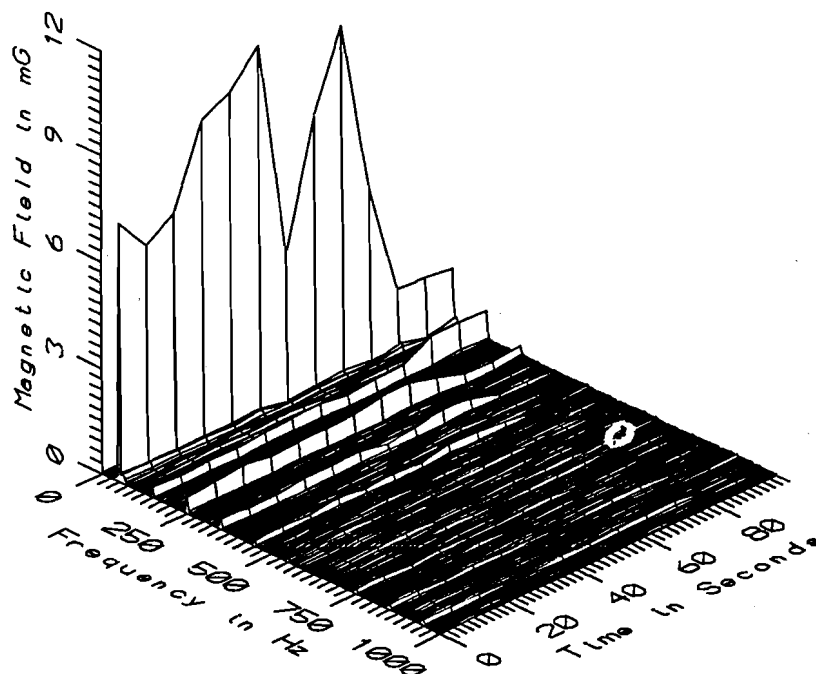

TGV017 - 110cm ABOVE FLOOR AT EDGE OF PLATFORM, VENDOME STATION

FIGURE 6-3. MAGNETIC FIELD LEVEL, WITH AND WITHOUT THE STATIC COMPONENT, AT 110 cm HEIGHT ABOVE THE PASSENGER PLATFORM AT VENDOME WHILE A TRAIN FROM PARIS PASSED BY, AS A FUNCTION OF FREQUENCY AND TIME

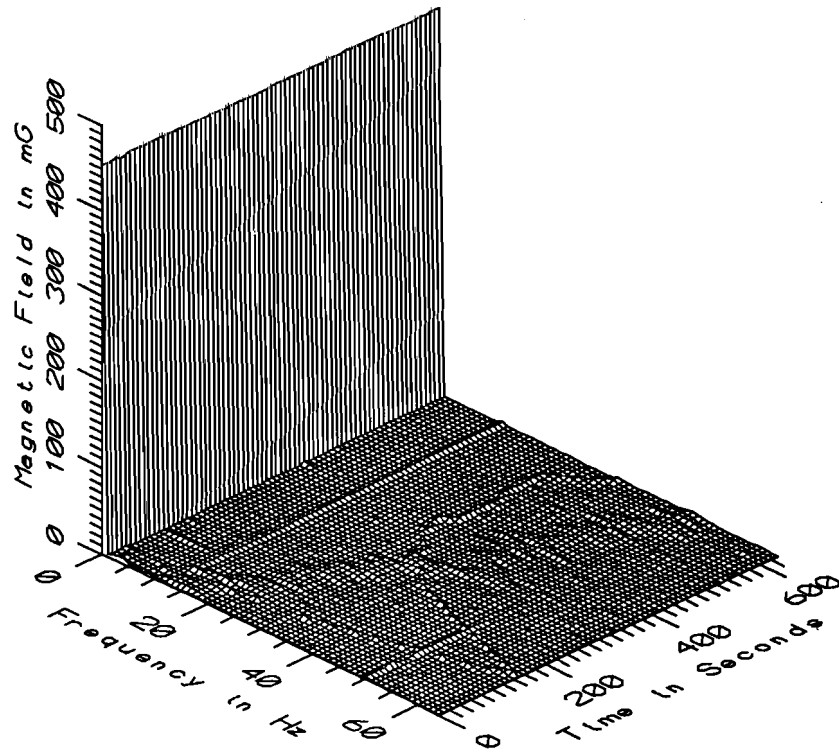

TGV018 - 110_{cm} ABOVE FLOOR AT EDGE OF PLATFORM, VENDOME STATION

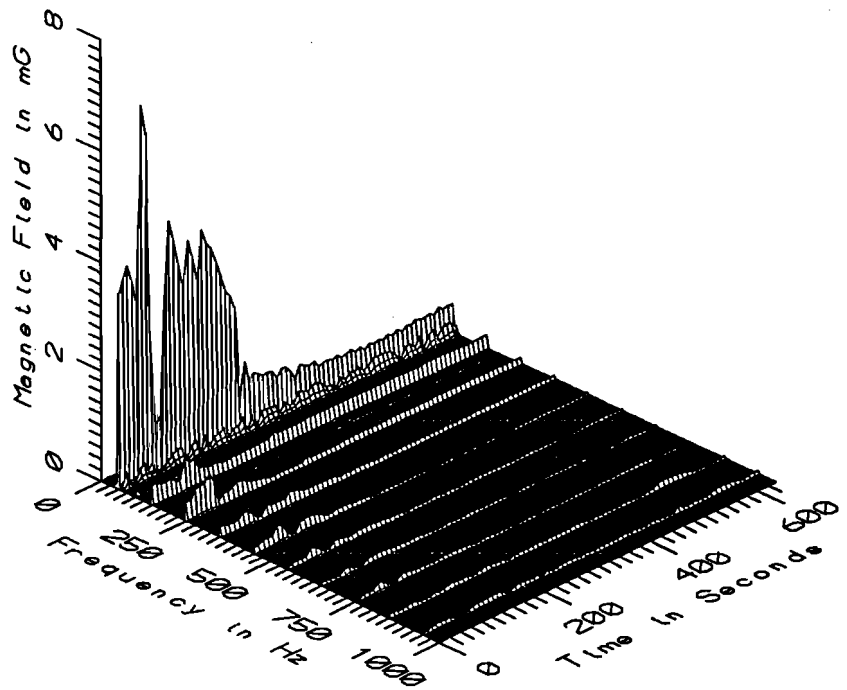

TGV018 - 110_{cm} ABOVE FLOOR AT EDGE OF PLATFORM, VENDOME STATION

FIGURE 6-4. MAGNETIC FIELD LEVEL, WITH AND WITHOUT THE STATIC COMPONENT, AT 110 cm HEIGHT ABOVE THE PASSENGER PLATFORM AT VENDOME WHILE ANOTHER TRAIN FROM PARIS PASSED BY, AS A FUNCTION OF FREQUENCY AND TIME

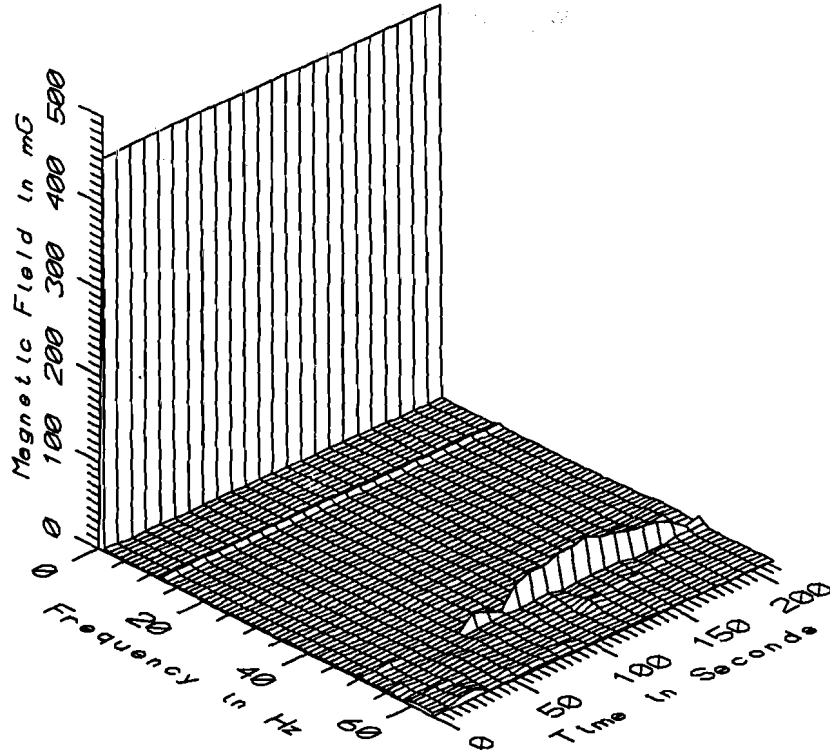

TGV019 - 110cm ABOVE FLOOR AT EDGE OF PLATFORM, VENDOME STATION

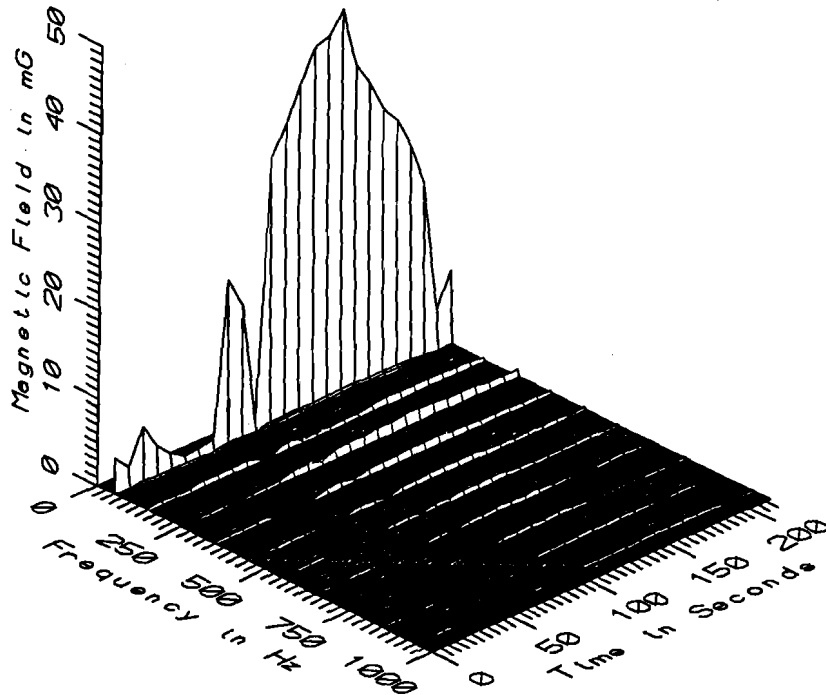

TGV019 - 110cm ABOVE FLOOR AT EDGE OF PLATFORM, VENDOME STATION

FIGURE 6-5. MAGNETIC FIELD LEVEL, WITH AND WITHOUT THE STATIC COMPONENT, AT 110 cm HEIGHT ABOVE THE PASSENGER PLATFORM AT VENDOME WHILE A TRAIN TO PARIS PASSED BY, AS A FUNCTION OF FREQUENCY AND TIME

the field versus time indicate that the source is perhaps the signalling system because it does not correlate with the power requirements of the locomotives.

Examination of the field data of the 10 cm probe on the staff and the reference probe shows the reference probe to be consistently higher for all three runs. For example, the peak values of the 50 Hz field, in mG, during the runs compare as indicated in Table 6-2. This indicates that there is a source of magnetic fields other than the catenary/track loop nearby and on the side of the platform away from the tracks. From the measurements taken at Vendome, one can not say with certainty what the other field source may be. However, as the data in Appendices R, S, and T indicate, the field produced by that source is temporally correlated with the magnetic field measured with the staff at the platform edge. The two most likely causes of increased magnetic field at the more distant measurement point are passive field perturbation by a piece of structural steel beneath the measurement point or localized magnetic field caused by a portion of the track return current flowing through the structural steel of the platform or in a buried conductor beneath that portion of the platform. Since the perturbation of the static geomagnetic field is comparable at both the staff and reference probe measurement points, passive enhancement due to field perturbation appears less likely than a localized magnetic field due to a small portion of the track return current flowing in metallic parts of the station platform very near the reference probe.

TABLE 6-2.

COMPARISON OF MAXIMUM RMS MAGNETIC FIELD LEVELS AT THE EDGE OF THE PLATFORM NEAR THE TRACKS (10 cm PROBE) AND A POINT 5 m (16.4 ft) MORE DISTANT (REFERENCE)

	10 cm PROBE	REFERENCE	RATIO
TGV017	10.70	22	2.06
TGV018	6.11	11	1.80
TGV019	41.41	110	2.66

6.4 DAT WAVEFORM DATA

Magnetic field data from the reference probe of the waveform capture system was recorded continuously with a Digital Audio Tape Recorder as described in Section 2.5. These recordings were scanned for short duration, high intensity magnetic fields or transient magnetic fields which could have been missed by the repetitive waveform sampling measurement technique. None were

found on the station platform, even as trains passed the station at high speed.

A statistical summary of rms magnetic field levels in the pass band of the DAT Recording System (0.1 Hz to 2.5 kHz) recorded on the Vendome Station platform is presented in Table 6-3. These values are in good agreement with those measured with the repetitive waveform sampling technique at the reference probe location (Appendices R, S, and T).

TABLE 6-3.

**SUMMARY OF MAGNETIC FIELD LEVELS
RECORDED AT THE PASSENGER STATION WITH
THE DIGITAL AUDIO TAPE RECORDER (DAT)**

TRAIN PASS (DATASETS)	MEASUREMENT LOCATION		MAGNETIC FIELD MILLIGAUSS, RMS		
	FIGURE #	LOCATION	MINIMUM	AVERAGE	MAXIMUM
1 (2/3)	6-1	20	1.9	5.7	25.8
2 (2/3)	6-1	20	0.1	2.0	12.4
3 (2/3)	6-1	20	1.9	26.8	99.6

6.5 RMS RECORDER DATA

For purpose of comparison two sets of rms recorder data are shown here as Figures 6-6 and 6-7. Figure 6-6 is the time course plot of the rms recording that corresponds to dataset TGV017. As it can be seen, the general shape and magnitudes correspond very well with the plot of TGV017, Figure 6-3. The 110 cm peak of dataset TGV017 is 10.51 mG and of the rms recorder is 11 mG. Figure 6-7 is the time course plot of the rms recording that corresponds to dataset TGV019. The general shape and magnitudes correspond well with the plot of TGV019, Figure 6-5. The 110 cm peak of dataset TGV019 is 43.68 mG and of the rms recorder is 55 mG.

VENDOME PLATFORM - TRAIN FROM PARIS

EMDEX II Data From September 8, 1992

6-10

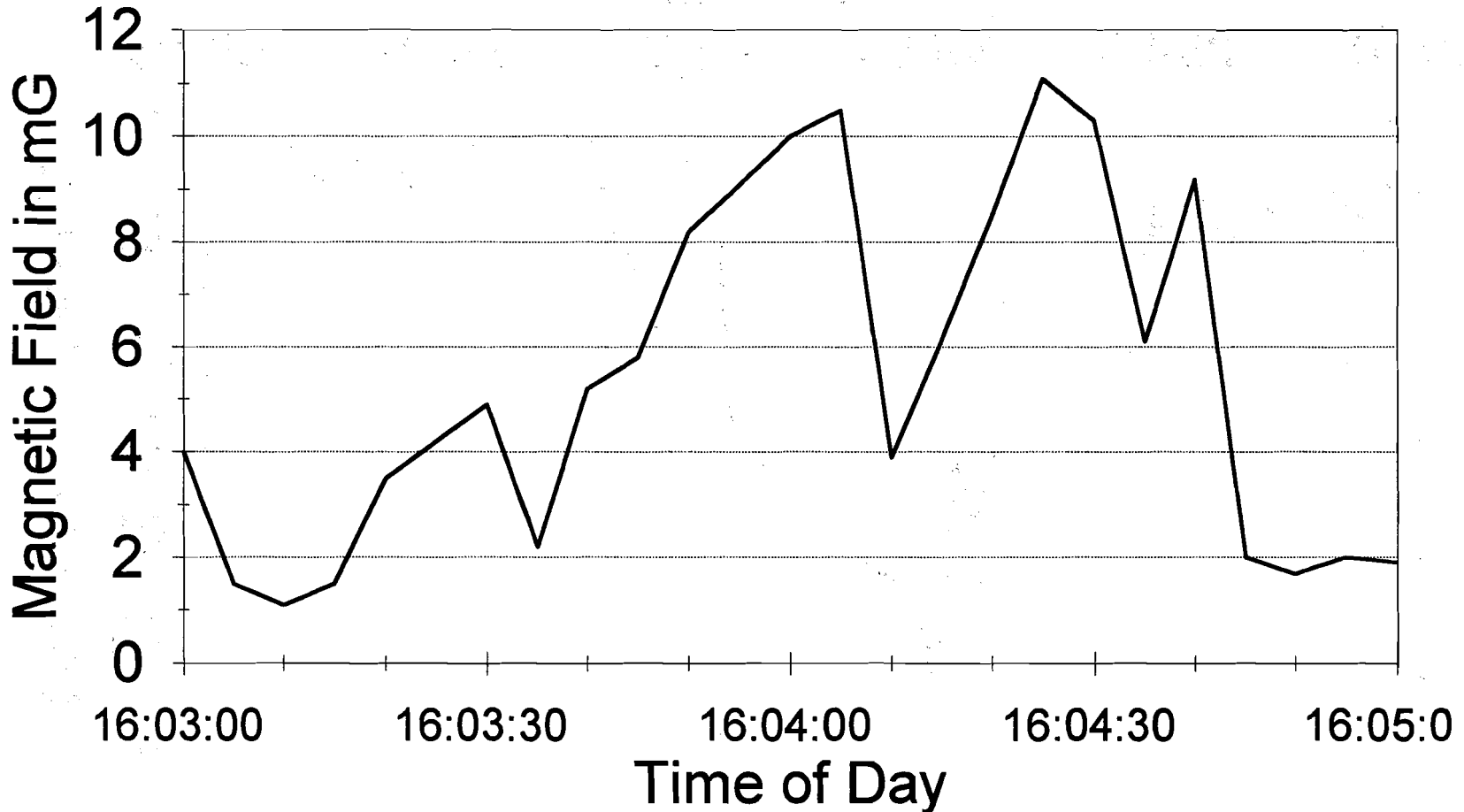
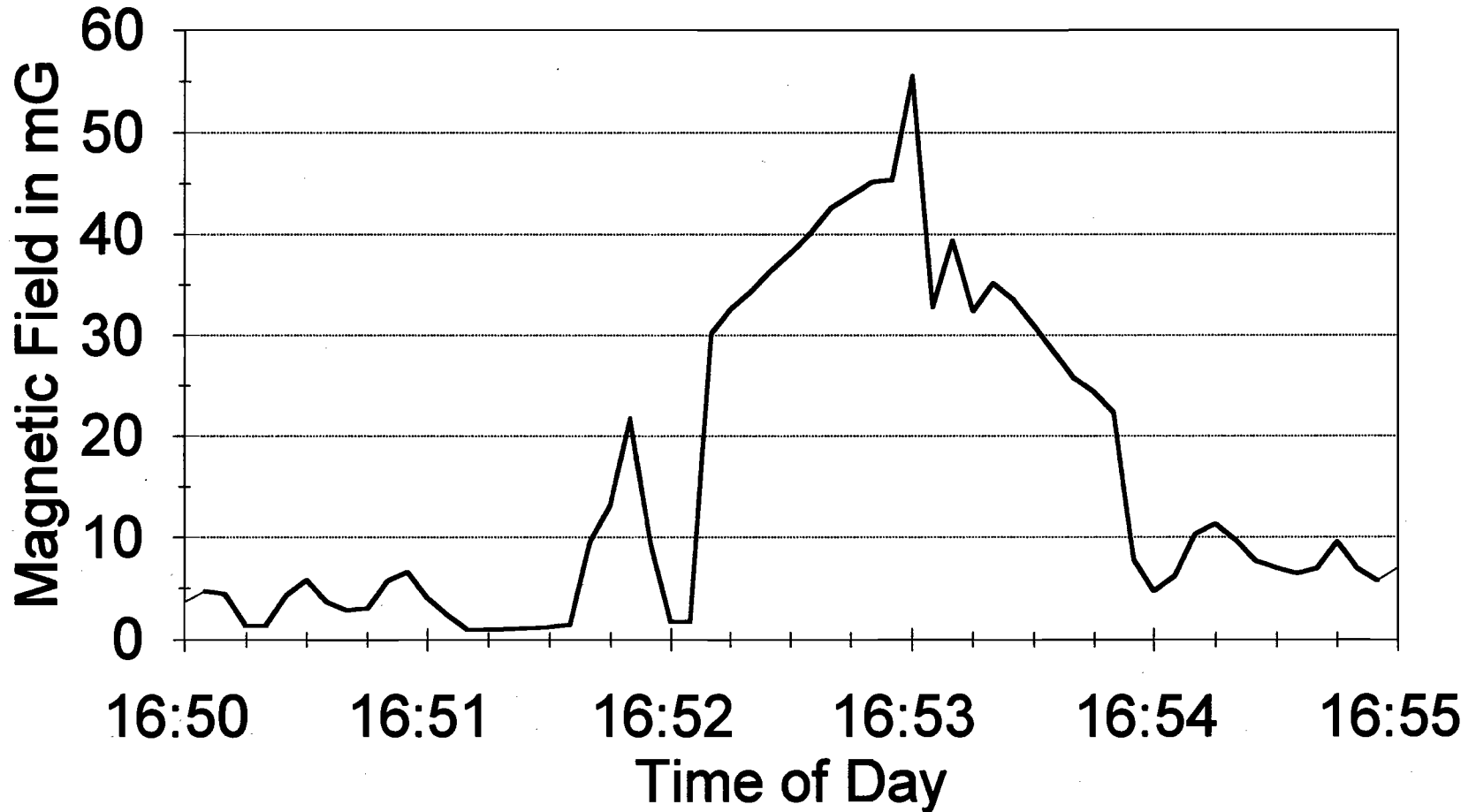

FIGURE 6-6. MAGNETIC FIELD LEVEL RECORDED ON THE PASSENGER PLATFORM AT VENDOME USING AN RMS RECORDER, WHILE A TRAIN FROM PARIS PASSED BY, AS A FUNCTION OF TIME

VENDOME PLATFORM - TRAIN TO PARIS

EMDEX II Data From September 8, 1992



6-11

FIGURE 6-7. MAGNETIC FIELD LEVEL RECORDED ON THE PASSENGER PLATFORM AT VENDOME USING AN RMS RECORDER, WHILE A TRAIN TO PARIS PASSES BY, AS A FUNCTION OF TIME

As stated previously, the difficulty in analyzing and interpreting rms recorder data is that the researchers carrying them do not follow a particular path, neither do they keep an exact log of their location. In any case, Table 6-4 contains the summary statistics of the rms recorder, as recorded while taking the other measurements at the platform. The table gives the minimum, average and maximum field levels, in mG, for two cases: while a train from Paris was passing by and then while a train to Paris was passing by. As previously stated, the magnetic field values of the train-to-Paris case are higher because the train track was nearer the platform and was a double train set.

TABLE 6-4.

**STATISTICAL SUMMARY OF MAGNETIC FIELDS
MEASURED ON THE PASSENGER PLATFORM
USING RMS DATA RECORDERS**

	MINIMUM	AVERAGE	MAXIMUM
TRAIN FROM PARIS SEP. 8, 1992			
RMS RECORDER #1 16:03:00-16:05:00	1.10 mG	5.38 mG	11.10 mG
RMS RECORDER #2 16:03:01-16:05:01	1.20 mG	9.16 mG	22.40 mG
COMBINATION	1.10 mG	7.27 mG	22.40 mG
TRAIN FROM PARIS SEP. 8, 1992			
RMS RECORDER #1 16:50:00-16:55:00	1.00 mG	16.03 mG	55.60 mG
RMS RECORDER #2 16:50:01-16:55:01	1.50 mG	21.38 mG	80.60 mG
COMBINATION	1.00 mG	18.71 mG	80.60 mG

6.6 SUMMARY OF MAGNETIC FIELD LEVELS

As discussed, the major sources of magnetic fields are the catenary/track loop, the primary feeder circuit and any other nearby station equipment or electric distribution lines. Tables 6-5 through 6-8 summarize the statistics of the three datasets taken at the platform. Each table shows the minimum, maximum and average field levels, as well as the standard deviation and

TABLE 6-5.

SUMMARY STATISTICS OF VERTICAL DATASET MEASURED ON THE VENDOME PASSENGER PLATFORM AS TRAIN FROM PARIS PASSED BY (DATASET TGV017)

TGV017 - ON VENDOME PLATFORM - TRAIN FROM PARIS					TOTAL OF 13 SAMPLES	
FREQUENCY BAND	HEIGHT ABOVE FLOOR (cm)	MINIMUM MAGNETIC FIELD (mG)	MAXIMUM MAGNETIC FIELD (mG)	AVERAGE MAGNETIC FIELD (mG)	STANDARD DEVIATION (mG)	COEFFICIENT OF VARIATION (%)
STATIC	10	473.34	478.86	477.55	1.50	0.31
	60	463.31	469.49	467.81	1.46	0.31
	110	449.21	455.78	454.40	1.65	0.36
	160	470.84	485.77	476.59	3.84	0.81
5-45Hz LOW FREQ	10	0.22	0.49	0.39	0.08	21.54
	60	0.19	0.44	0.32	0.07	23.21
	110	0.16	0.39	0.28	0.07	27.14
	160	0.26	0.45	0.35	0.06	16.31
50-60Hz PWR FREQ	10	1.53	10.70	6.36	3.29	51.71
	60	1.45	10.85	6.41	3.34	52.09
	110	1.58	10.51	6.26	3.21	51.25
	160	1.66	10.13	6.07	3.03	49.99
65-300Hz PWR HARM	10	0.76	1.01	0.86	0.07	8.57
	60	0.78	0.99	0.88	0.07	8.14
	110	0.69	0.99	0.85	0.10	12.06
	160	0.67	1.00	0.83	0.09	10.91
305-2560Hz HIGH FREQ	10	1.09	1.48	1.31	0.13	9.98
	60	1.01	1.47	1.25	0.15	12.10
	110	0.96	1.46	1.22	0.17	13.62
	160	1.09	1.44	1.27	0.12	9.37
5-2560Hz ALL FREQ	10	2.09	10.84	6.63	3.14	47.28
	60	1.98	10.98	6.66	3.19	47.88
	110	2.08	10.65	6.51	3.07	47.26
	160	2.21	10.27	6.33	2.89	45.62

TABLE 6-6.

SUMMARY STATISTICS OF VERTICAL DATASET MEASURED ON THE VENDOME PASSENGER PLATFORM AS TRAIN FROM PARIS PASSED BY (DATASET TGV018)

TGV018 - ON VENDOME PLATFORM - TRAIN FROM PARIS					TOTAL OF 73 SAMPLES	
FREQUENCY BAND	HEIGHT ABOVE FLOOR (cm)	MINIMUM MAGNETIC FIELD (mG)	MAXIMUM MAGNETIC FIELD (mG)	AVERAGE MAGNETIC FIELD (mG)	STANDARD DEVIATION (mG)	COEFFICIENT OF VARIATION (%)
STATIC	10	474.72	477.05	476.41	0.35	0.07
	60	466.49	469.38	468.26	0.50	0.11
	110	451.61	456.11	454.62	0.61	0.13
	160	473.88	480.00	476.75	1.30	0.27
5-45Hz LOW FREQ	10	0.10	0.37	0.25	0.08	33.89
	60	0.16	0.26	0.18	0.02	9.85
	110	0.06	0.23	0.12	0.03	26.93
	160	0.16	0.29	0.19	0.02	12.18
50-60Hz PWR FREQ	10	0.48	6.11	1.52	1.41	92.81
	60	0.49	6.49	1.58	1.49	94.32
	110	0.49	6.76	1.64	1.53	93.52
	160	0.51	6.98	1.66	1.58	95.06
65-300Hz PWR HARM	10	0.20	0.68	0.30	0.11	36.39
	60	0.22	0.68	0.31	0.11	35.52
	110	0.21	0.70	0.33	0.11	33.07
	160	0.22	0.71	0.32	0.11	35.15
305-2560Hz HIGH FREQ	10	0.18	0.50	0.24	0.05	22.56
	60	0.15	0.50	0.22	0.06	28.89
	110	0.12	0.52	0.22	0.07	32.04
	160	0.11	0.52	0.20	0.07	37.82
5-2560Hz ALL FREQ	10	0.63	6.18	1.63	1.36	83.79
	60	0.62	6.55	1.67	1.46	87.38
	110	0.59	6.82	1.72	1.50	87.41
	160	0.61	7.04	1.74	1.55	88.95

TABLE 6-7.

SUMMARY STATISTICS OF VERTICAL DATASET MEASURED ON THE VENDOME PASSENGER PLATFORM AS TRAIN TO PARIS PASSED BY (DATASET TGV019)

TGV019 - ON VENDOME PLATFORM - TRAIN TO PARIS				TOTAL OF 25 SAMPLES		
FREQUENCY BAND	HEIGHT ABOVE FLOOR (cm)	MINIMUM MAGNETIC FIELD (mG)	MAXIMUM MAGNETIC FIELD (mG)	AVERAGE MAGNETIC FIELD (mG)	STANDARD DEVIATION (mG)	COEFFICIENT OF VARIATION (%)
STATIC	10	476.01	477.00	476.45	0.21	0.04
	60	467.70	468.70	468.18	0.26	0.06
	110	453.11	454.78	454.16	0.45	0.10
	160	473.29	476.59	475.14	0.99	0.21
5-45Hz LOW FREQ	10	0.12	0.85	0.48	0.23	48.38
	60	0.16	0.86	0.44	0.25	58.01
	110	0.10	0.86	0.41	0.29	69.78
	160	0.17	0.89	0.46	0.27	58.29
50-60Hz PWR FREQ	10	0.77	41.41	17.54	14.45	82.37
	60	0.77	42.10	18.29	15.07	82.39
	110	0.81	43.68	18.77	15.60	83.08
	160	0.83	43.83	18.98	15.79	83.19
65-300Hz PWR HARM	10	0.20	1.54	0.83	0.40	47.80
	60	0.21	1.54	0.87	0.41	47.22
	110	0.24	1.57	0.90	0.42	46.35
	160	0.21	1.59	0.87	0.42	47.69
305-2560Hz HIGH FREQ	10	0.18	1.20	0.59	0.31	53.00
	60	0.14	1.23	0.61	0.34	55.80
	110	0.12	1.28	0.64	0.37	57.42
	160	0.10	1.27	0.60	0.36	60.52
5-2560Hz ALL FREQ	10	0.97	41.46	17.61	14.42	81.85
	60	0.92	42.15	18.36	15.04	81.93
	110	0.96	43.73	18.84	15.57	82.63
	160	0.97	43.88	19.04	15.76	82.77

TABLE 6-8.

SUMMARY STATISTICS OF COMBINED VERTICAL DATASETS MEASURED ON THE VENDOME PASSENGER PLATFORM (DATASETS TGV017, 18 AND 19)

TGV017, TGV018, TGV019 - ON VENDOME PLATFORM					TOTAL OF 111 SAMPLES	
FREQUENCY BAND	HEIGHT ABOVE FLOOR (cm)	MINIMUM MAGNETIC FIELD (mG)	MAXIMUM MAGNETIC FIELD (mG)	AVERAGE MAGNETIC FIELD (mG)	STANDARD DEVIATION (mG)	COEFFICIENT OF VARIATION (%)
STATIC	10	473.34	478.86	476.55	0.69	0.14
	60	463.31	469.49	468.19	0.66	0.14
	110	449.21	456.11	454.49	0.79	0.17
	160	470.84	485.77	476.37	1.84	0.39
5-45Hz LOW FREQ	10	0.10	0.85	0.32	0.16	51.07
	60	0.16	0.86	0.25	0.16	65.11
	110	0.06	0.86	0.20	0.19	93.31
	160	0.16	0.89	0.27	0.17	64.55
50-60Hz PWR FREQ	10	0.48	41.41	5.69	9.57	168.08
	60	0.49	42.10	5.91	9.98	168.87
	110	0.49	43.68	6.04	10.27	170.03
	160	0.51	43.83	6.08	10.38	170.88
65-300Hz PWR HARM	10	0.20	1.54	0.49	0.33	68.27
	60	0.21	1.54	0.51	0.34	67.65
	110	0.21	1.57	0.52	0.34	65.50
	160	0.21	1.59	0.50	0.34	67.21
305-2560Hz HIGH FREQ	10	0.18	1.48	0.44	0.38	86.22
	60	0.14	1.47	0.43	0.38	88.80
	110	0.12	1.46	0.43	0.38	88.15
	160	0.10	1.44	0.41	0.40	96.86
5-2560Hz ALL FREQ	10	0.63	41.46	5.81	9.54	164.05
	60	0.62	42.15	6.01	9.95	165.58
	110	0.59	43.73	6.14	10.25	167.00
	160	0.61	43.88	6.17	10.36	167.80

coefficient of variation of the sample set. The results are summarized by the same set of frequency ranges used throughout this report, and by the height above the platform of the sensor. There were four sensor locations mounted on the staff.

Table 6-5 has the overall statistics of dataset TGV017, which was taken while a train from Paris was passing. The maximum reading of 10.85 mG occurred in the power frequency range, at the 60 cm height. However, the difference between the maxima of all four heights is less than 7%. As expected, the highest coefficients of variation occurred at the power frequency.

Table 6-6 has the overall statistics of dataset TGV018, which was also recorded while a train from Paris was passing. The maximum reading of 6.98 mG occurred at the power frequency, at the 160 cm height. However, the difference between the maxima of all four heights is less than 13%. Again, as expected, the highest coefficients of variation occurred in the power frequency range.

Table 6-7 has the overall statistics of dataset TGV019, which was recorded while a train to Paris was passing. The maximum reading of 43.83 mG occurred in the power frequency range, at the 160 cm height. However, the difference between the maxima of all four heights is less than 6%. Again, the highest coefficients of variation occurred in the same power frequency range. As expected, the magnetic field values of the train-to-Paris case are higher because the Paris bound train track is nearer the platform and the train was a double train set.

Table 6-8 has the overall statistics of all three datasets, indicating the levels that could be expected on a platform while trains are passing by. The results combine data recorded while trains were passing to and from Paris. The maximum readings are the maxima of the previous cases. Again, the highest coefficients of variation occurred in the power frequency range. The lowest coefficients of variation appear in the static range, indicating that the static field is not perturbed by the passing trains.

7. POWER SUPPLY SYSTEM MEASUREMENTS

The power supply system for the railway is comprised of catenaries, rails, primary feeders, autotransformers, and substations. The catenaries, rails and feeders are part of the investigation throughout previous sections of this report. This section covers the recording of the fields in and around a substation and an autotransformer installation.

7.1 MEASUREMENT LOCATIONS

Figure 7-1 shows the *Gault St. Denis* substation located at the 94.75 km marker of the Atlantic TGV-A Line. Power comes in at 220 kV, 50 Hz and is transformed into 50 kV (also known as 2x25 kV) which is used to supply the autotransformers along the line.

As shown in the figure, fixed position extended time measurements were made at locations both outside and inside the substation. The outside measurements correspond to datasets TGV032 and TGV033. The inside set was taken inside the control house and it is referenced as TGV034. The data was collected between 15:18 and 15:56 on September 9, 1992. For the outside measurements, the staff was placed vertically at a distance of 2 m (6.6 ft) from the fence, at a location midway along the portion of the energized low voltage bus which ran parallel to the substation fence. This location was chosen because it was expected to be the area outside the substation fence with the highest magnetic fields. The reference probe was placed at a distance of 17 m (56 ft) from the fence. For the inside measurements, the staff was placed vertically inside the control house where personnel might stand while inspecting various station instruments. The reference probe was placed outside the control house, below the low voltage bus, 7 m (23 ft) from the staff. This location was chosen because it was expected to be the point with the highest magnetic fields within the substation where personnel might routinely walk. Lateral profiles of electric field were measured at two locations outside the substation. Those locations are also shown on Figure 7-1. One location was on the side of the substation facing the general public and the other was on the end of the substation near the high voltage yard where the electric fields were expected to be the greatest.

Figure 7-2 shows the autotransformer station at *Chaillot*, at the 120.875 km marker. Chaillot was chosen to avoid the effects of any nearby EDF transformer and therefore allow focus on TGV-A autotransformer fields. The station measures approximately 25 by 8.5 m (82 by 28 ft). The staff was placed vertically at a distance of 2 m (6.6 ft) from the fence, in a location halfway between the two transformers. The reference probe was located at

Gault St. Denis Substation

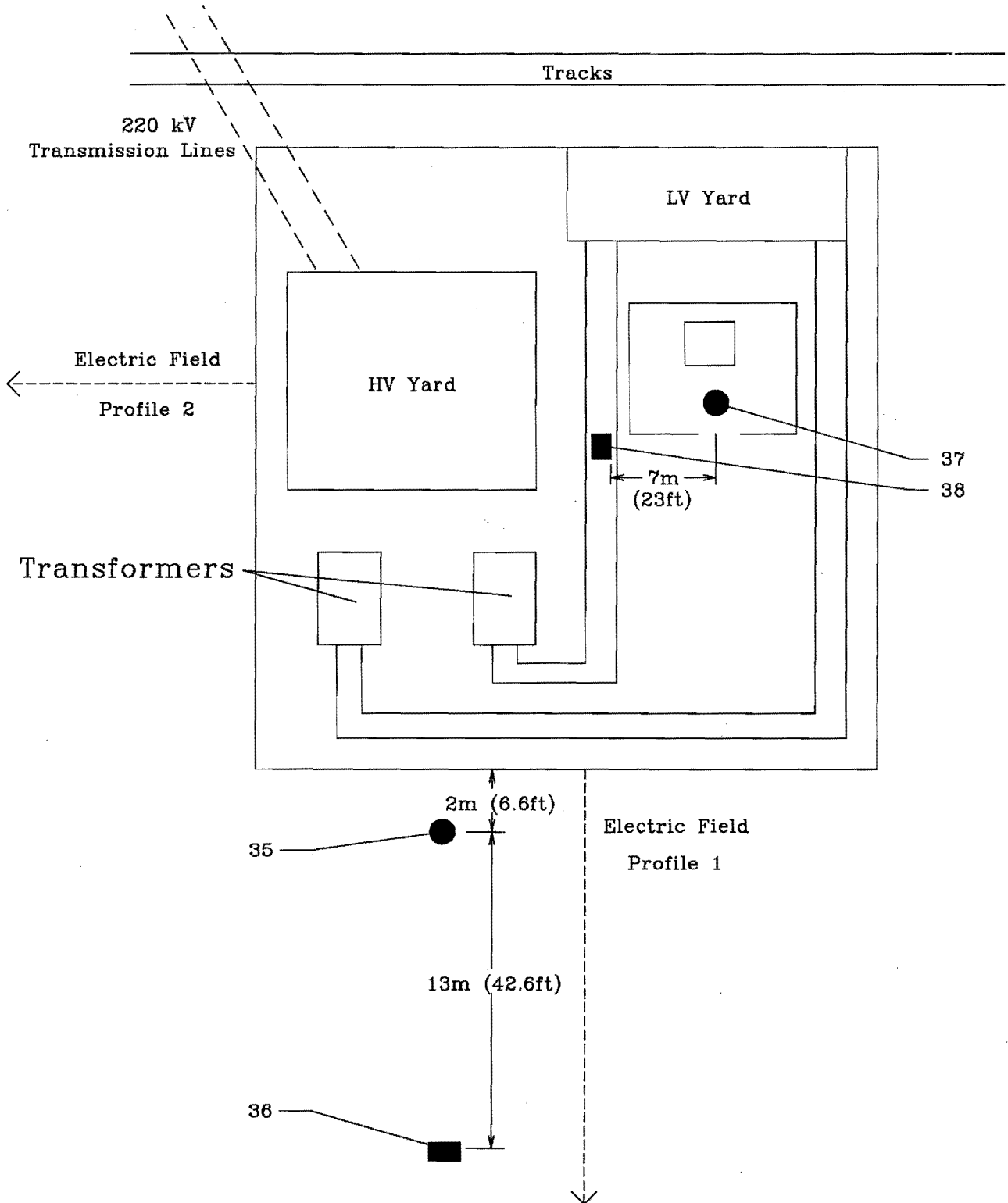

FIGURE 7-1. REPETITIVE WAVEFORM MEASUREMENT LOCATIONS AT THE GAULT ST. DENIS SUBSTATION, ALSO SHOWING THE ELECTRIC FIELD PROFILES

Auto-Transformer Station Chaillot at Marker 120.875km

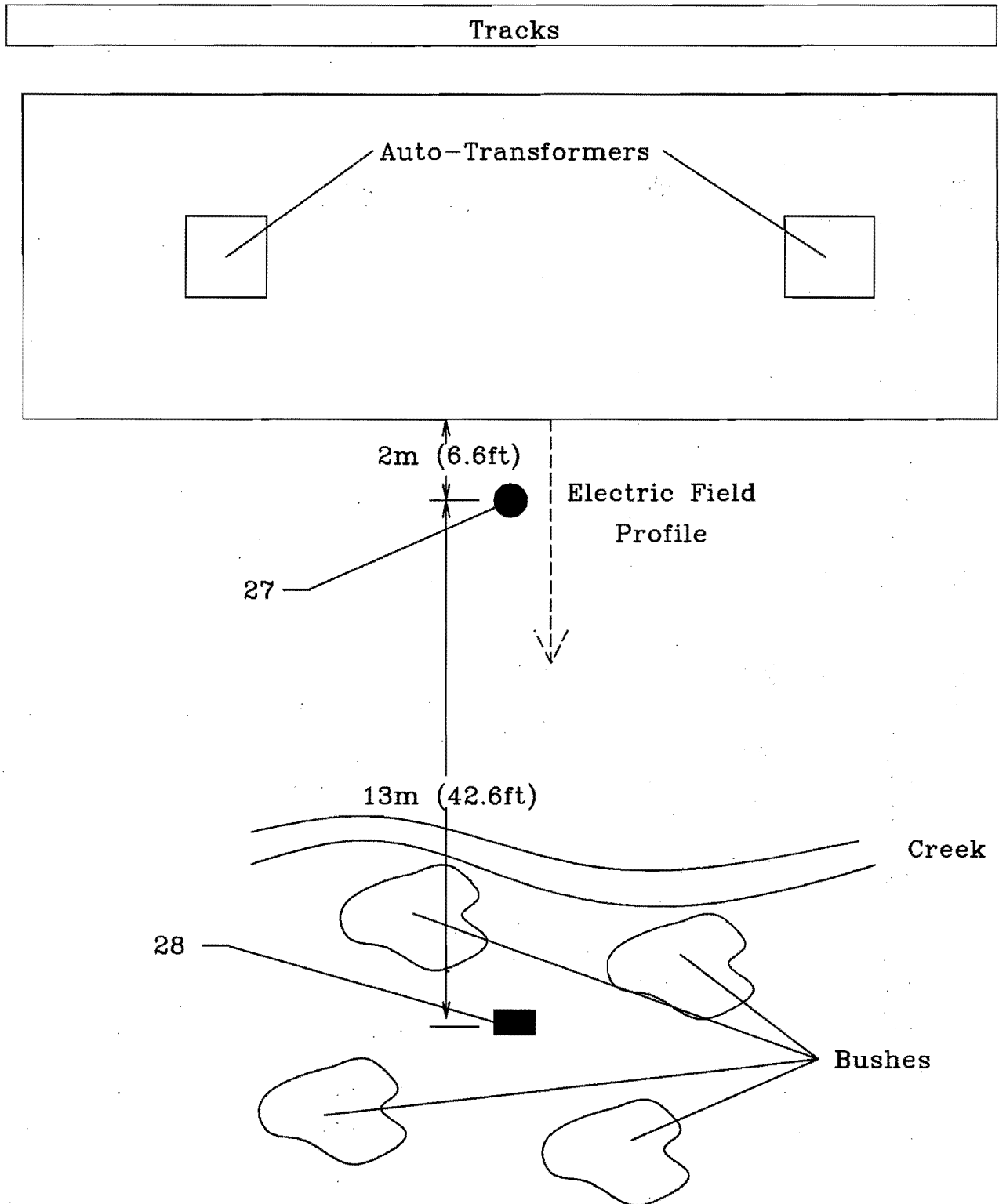

FIGURE 7-2. REPETITIVE WAVEFORM MEASUREMENT LOCATIONS AT THE CHAILLOT AUTOTRANSFORMER STATION, ALSO SHOWING THE ELECTRIC FIELD PROFILE

a distance of 15 m (49 ft) from the fence, or 13 m (43 ft) from the staff. Measurements were taken on September 9, 1992 from 09:16 to 09:34. Electric field measurements were also taken, at a profile perpendicular to the station fence.

7.2 REPETITIVE WAVEFORM DATASETS

The five repetitive waveform datasets that are associated with the substation and autotransformer measurements are shown in Table 7-1. The data was recorded with the repetitive field waveform monitoring system. This table summarizes the pertinent information about these datasets, including the number of samples and information about the trains that pass by. The sampling interval is 10 seconds for all sets.

TABLE 7-1.

REPETITIVE MAGNETIC FIELD WAVEFORM DATASETS MEASURED NEAR A SUBSTATION AND AN AUTOTRANSFORMER STATION

DATA FILE NUMBER	DATE/TIME	LOCATION FIG. # STAFF/REF	# OF SAMPLES & RATE	APPENDIX	REMARKS
TGV032	SEP. 9 15:18-15:22	7-1 35/36	25 10 SEC	AG	OUTSIDE SUBSTATION SNGL TRAIN
TGV033	SEP. 9 15:25-15:28	7-1 35/36	19 10 SEC	AH	OUTSIDE SUBSTATION DBL TRN SET
TGV034	SEP. 9 15:43-15:56	7-1 37/38	68 10 SEC	AI	INSIDE SUB. CONTROL RM. THREE TRNS
TGV027	SEP. 9 10:16-10:18	7-2 27/28	12 10 SEC	AB	AUTOXFRMER STATION
TGV028	SEP. 9 10:26-10:34	7-2 27/28	36 10 SEC	AC	AUTOXFRMER SNGL TRAIN

The TGV032 dataset, outside the substation, captured the data for a single train set going to Paris. The TGV033 dataset has a double train set starting at 100 seconds. The TGV034 dataset has three trains, the first from Paris starting at the 280 second point; the second from Paris and the third to Paris.

As for the autotransformer recordings, the TGV028 dataset has a single train starting with the 270 second point.

Appendices AG, AH, AI, AB and AC contain the figures of the five datasets shown in the table. These figures show three-dimensional graphs of the magnetic fields near the substations, as measured by the waveform capture system.

7.3 FIELD SOURCE IDENTIFICATION

Substation magnetic fields arise from several sources. The most common are the incoming transmission lines, the outgoing lines that connect to the feeders and catenaries, the buswork inside the substation, and the transformers and other equipment inside the substation. This study measured the magnetic fields outside and inside the substation at locations where the general public or workers might encounter the highest fields.

Figure 7-3 is the TGV033 dataset plot of the 110 cm staff sensor data, taken at 2 m (6.6 ft) outside the substation fence. As it can be seen, there are basically three parts to these frequencies: The static component, 50 Hz and its harmonics, and a small low frequency component which is most likely related to signal and control. The static component is constant with time, and varies very slightly with vertical distance. There are slightly higher readings at the top than the other parts of the staff. This is probably due to the nearby fence.

The 50 Hz and its odd harmonics, namely the 3rd (150 Hz), the 5th (250 Hz), the 7th (350 Hz), the 9th (450 Hz), the 11th (550 Hz) etc., have the same temporal variation pattern, which indicates that they all are related to the same source. The variation reflects the load drawn by trains in that portion of the circuit currents flowing in the low voltage area of the substation.

The researcher's notebook log indicates that a double train set passed starting at the 100 second mark. The magnetic field appears to be present, at about the same magnitude, regardless of the train's immediate proximity to the station. That is expected because this substation provides power to an extended portion of the line, not just the adjacent power block. This indicates that the major variation of the field comes from the variation of the load in the substation circuits that feed power both ways on the railway line. That load depends on the number of trains operating in the central portion of the line fed by this substation and the power needs of each. The maximum field value recorded in either dataset (TGV032 and TGV033) was 8.99 mG at the 160 cm height of dataset TGV033.

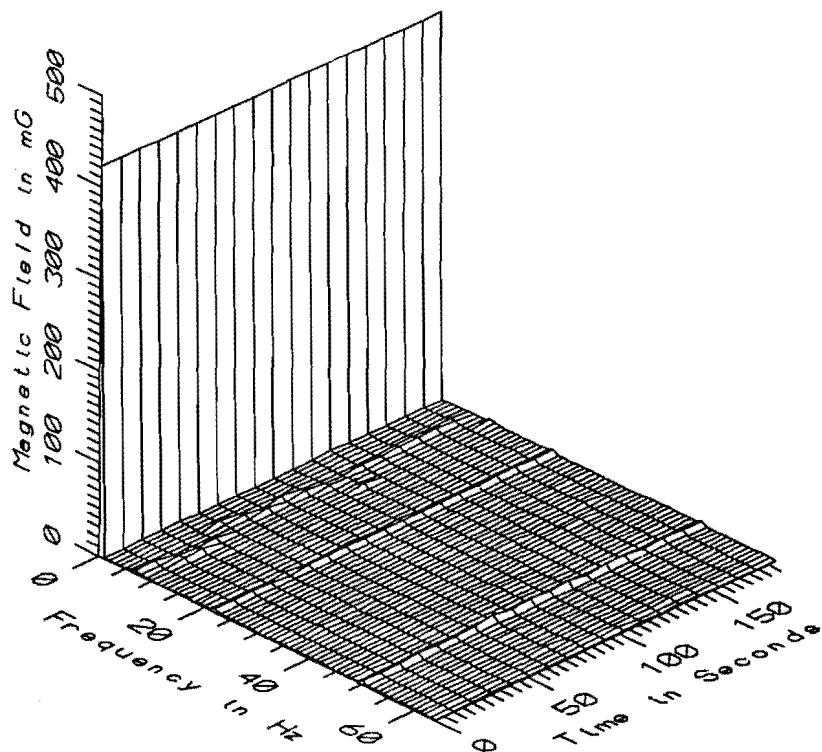

TGV033 - 110cm ABOVE GROUND NEAR FENCE OF GAULT ST. DENIS SUBSTATION

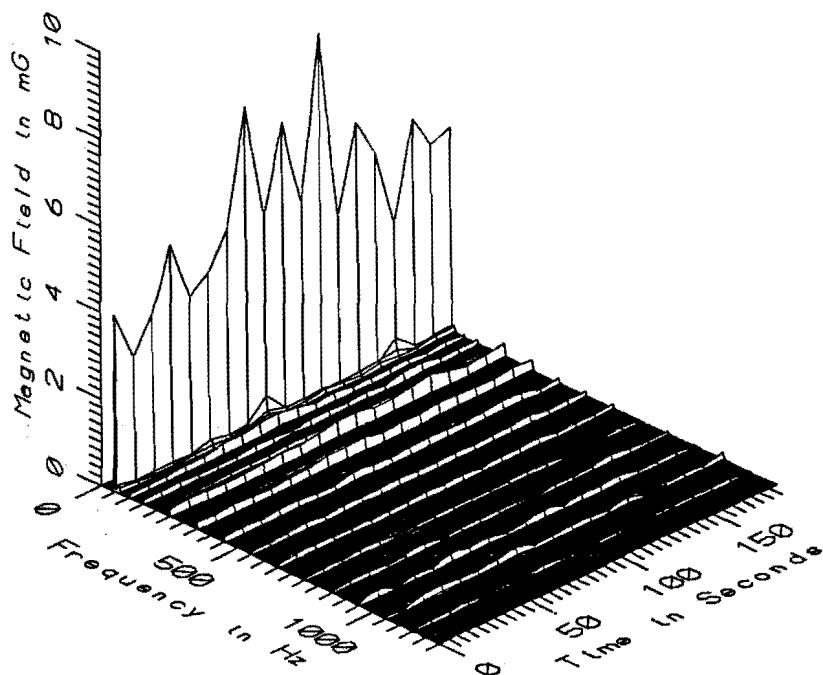

TGV033 - 110cm ABOVE GROUND NEAR FENCE OF GAULT ST. DENIS SUBSTATION

FIGURE 7-3. MAGNETIC FIELD LEVEL, WITH AND WITHOUT THE STATIC COMPONENT, AT 110 cm HEIGHT ABOVE GROUND NEAR THE FENCE AT GAULT ST. DENIS SUBSTATION, AS A FUNCTION OF FREQUENCY AND TIME

Figure 7-4 is the TGV034 dataset plot of the 110 cm height data taken inside the control house. As expected, the temporal variations of the 50 Hz and its odd harmonics are similar at all four measurement heights above the floor. This also indicates that the source of the magnetic field is the power supplied by the substation. The field values increase with height, as expected, because the field source is apparently the overhead secondary bus just outside the control house. The maximum value of this dataset was 34.26 mG at the 160 cm height.

The reference probe of dataset TGV034 was placed inside the substation, underneath the main bus structure, just outside the control house, position 38 in Figure 7-1. As expected, the reference probe recorded the highest field value of 160 mG, because the reference probe was placed in a location that is physically near the main current carrying structures.

There are two datasets, TGV027 and TGV028, that were recorded outside an autotransformer station. Both sets yield approximately the same data. Dataset TGV028 is chosen for purposes of illustration. Figure 7-5 is the TGV028 dataset plot of the 110 cm data, at 2 m (6.6 ft) outside the autotransformer station fence. As it can be seen, the general temporal characteristic and magnitude of the field are similar to the measurements recorded outside the substation. The static component is constant with time and vertical distance. As in the case of the substation recordings, the odd power harmonics vary directly with the fundamental, which is a further indication that the source is the load carried by the transformers. The researcher's notebook log indicates that a single train set passed by, starting at the 270 second mark. The magnetic field plot of Figure 7-5 correlates well with that, as the field appears to increase when the train is in close proximity to the autotransformer station. This indicates again that the major variation of the field comes from the variation of the load in the substation circuits.

In summary, the repetitive waveform data of the power supply circuits and equipment indicate temporal variations in the field levels as a function of the load imposed on them. This load, in turn, results from the actual position and running condition of the trains in that electrical portion of the circuit. Also, there are wide spatial variations, depending on the proximity to the main current carrying structures.

7.4 DAT WAVEFORM DATA

Magnetic field data from the reference probe of the waveform capture system was recorded continuously with a Digital Audio Tape Recorder as described in Section 2.5. A scan of the DAT waveform data revealed neither magnetic fields with rapid transients nor extremely brief bursts of high intensity ELF magnetic fields.

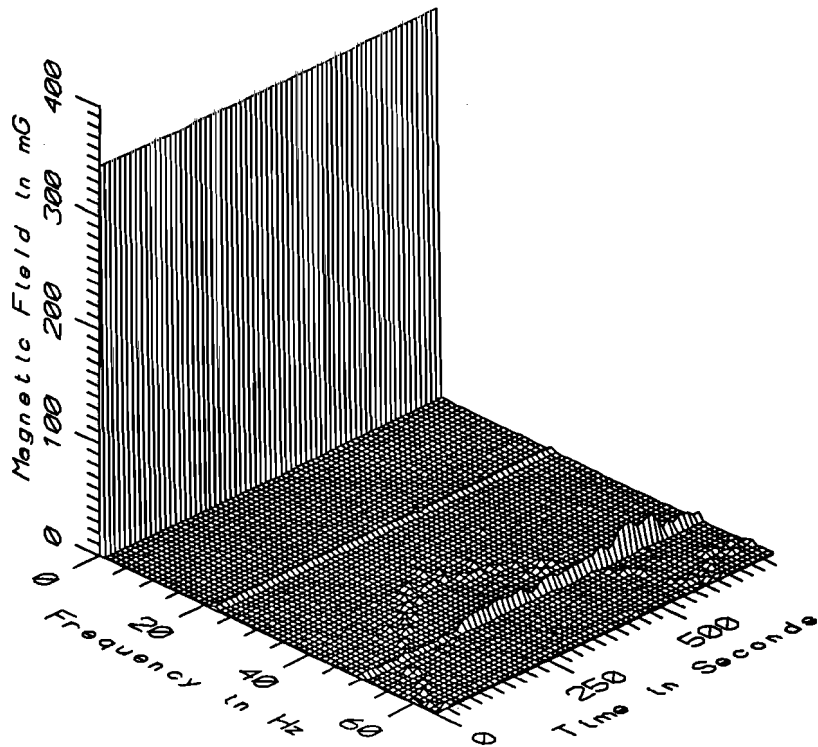

TGV034 - 110cm ABOVE FLOOR IN CONTROL HOUSE, GAULT ST. DENIS SUBSTATION

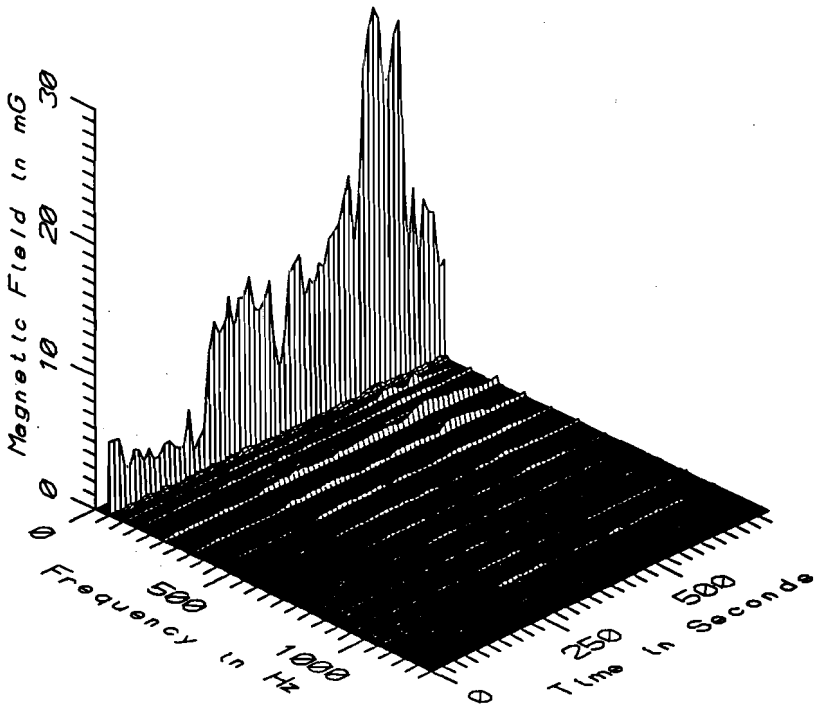

TGV034 - 110cm ABOVE FLOOR IN CONTROL HOUSE, GAULT ST. DENIS SUBSTATION

FIGURE 7-4. MAGNETIC FIELD LEVEL, WITH AND WITHOUT THE STATIC COMPONENT, AT 110 cm HEIGHT ABOVE GROUND INSIDE THE CONTROL HOUSE AT GAULT ST. DENIS SUBSTATION, AS A FUNCTION OF FREQUENCY AND TIME

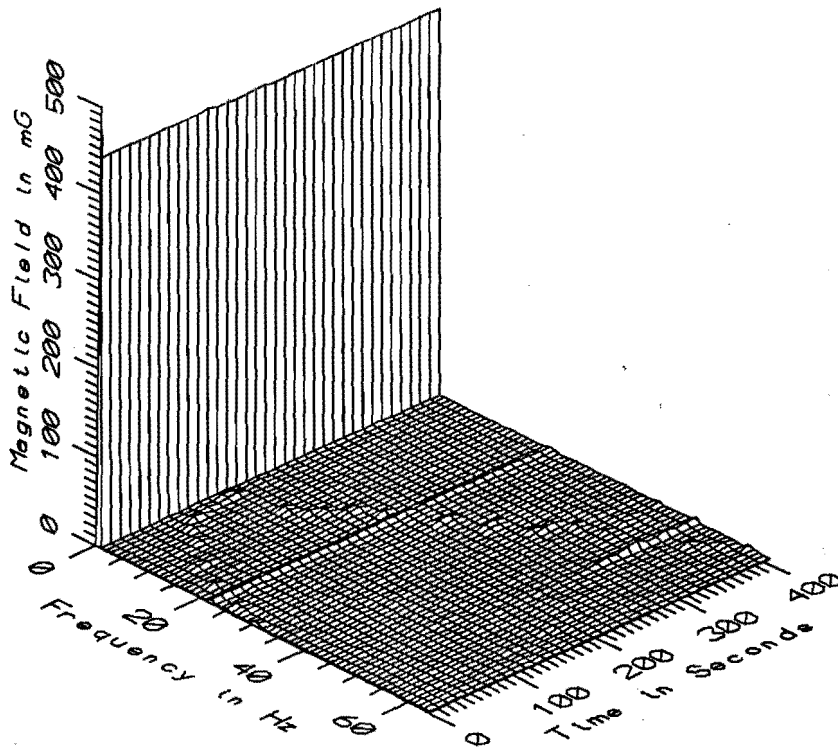

TGV028 - 110cm ABOVE GROUND AT CHAILLOT AUTO-TRANSFORMER, 121km MARKER

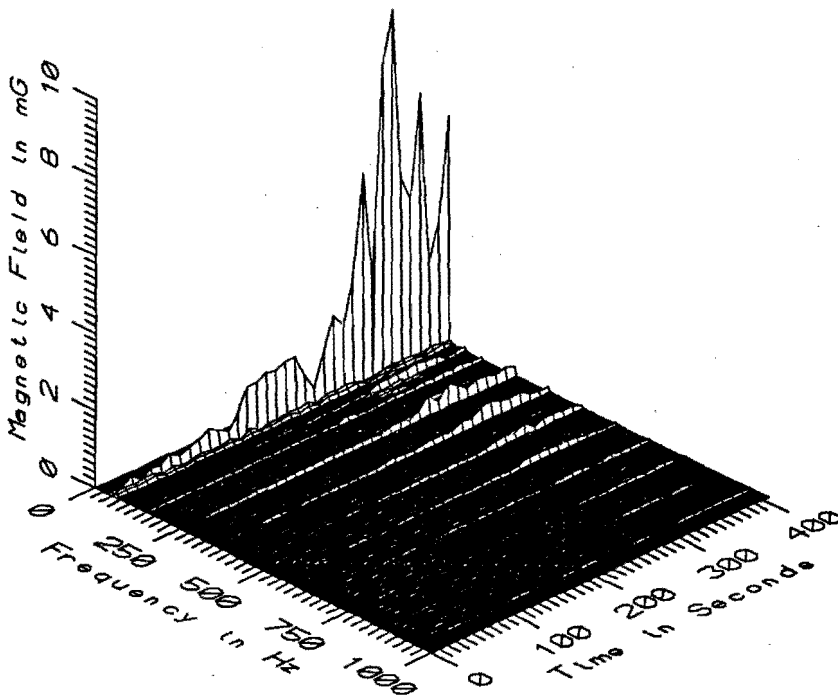

TGV028 - 110cm ABOVE GROUND AT CHAILLOT AUTO-TRANSFORMER, 121km MARKER

FIGURE 7-5. MAGNETIC FIELD LEVEL, WITH AND WITHOUT THE STATIC COMPONENT, AT 110 cm HEIGHT ABOVE GROUND NEAR THE FENCE AT CHAILLOT AUTOTRANSFORMER STATION, AS A FUNCTION OF FREQUENCY AND TIME

Changes in magnetic field level resulting from trains entering or leaving the portion of line supplied by this substation and autotransformer station appear to occur rather gradually over several cycles as do the changes in magnetic field level resulting from changes in power requirements of trains within the power block.

A statistical summary of rms magnetic field levels in the pass band of the DAT Recording System (0.1 Hz to 2.5 kHz) recorded outside a substation and an autotransformer station, as well as within a substation, is presented in Table 7-2. The minimum and average magnetic field levels reported in Table 7-2 for measurement locations outside the substation and autotransformer station are somewhat affected by noise in the recording system. Therefore, they tend to overestimate the actual magnetic field level.

TABLE 7-2.

**SUMMARY OF MAGNETIC FIELD LEVELS RECORDED
NEAR A SUBSTATION AND AN AUTOTRANSFORMER STATION
WITH THE DIGITAL AUDIO TAPE RECORDER (DAT)**

(DATASETS)	MEASUREMENT LOCATION		MAGNETIC FIELD MILLIGAUSS, RMS		
	FIGURE #	LOCATION	MINIMUM	AVERAGE	MAXIMUM
OUTSIDE SUBSTATION (4-1)	7-1	36	0.6	1.4	2.7
INSIDE SUBSTATION (4-2)	7-1	38	2.6	41.2	147.2
OUTSIDE AUTOTRANSFORMER STATION (3-3)	7-2	28	0.6	1.2	5.4

7.5 RMS RECORDER DATA

The rms recorders are carried on a person and thus reflect the history in time and space of that person. The difficulty is that the researchers, in this study, did not follow any particular path that would correspond to either passengers or railroad employees. Moreover, it is difficult to correlate with other measurements. However, a summary of both rms recordings is shown here.

Magnetic field data measured with the rms recorders was collected at both the *Gault St. Denis* substation and the *Chaillot* autotransformer and in their vicinities. Table 7-3 has the statistics for individual records and for the pooled data at the autotransformer site where data from two rms recorders were available. Only one record is available for the substation because the second recorder was turned off prematurely. It can be seen that there are substantial differences in the detail records even though the two researchers worked near each other.

TABLE 7-3.

**STATISTICAL SUMMARY OF MAGNETIC FIELDS IN mG
MEASURED AT THE GAULT ST. DENIS SUBSTATION
AND THE CHAILLOT AUTOTRANSFORMER
USING RMS DATA RECORDERS**

	MINIMUM	AVERAGE	MAXIMUM
SUBSTATION SEP. 9, 1992			
RMS RECORDER #2 15:18:21-15:55:33	0.10	4.41	72.40
AUTOTRANSFORMER SEP. 9, 1992			
RMS RECORDER #1 10:15:48-10:33:33	0.00	6.34	55.00
RMS RECORDER #2 10:15:48-10:33:33	0.10	1.89	14.20
COMBINATION	0.00	4.12	55.00

7.6 SUMMARY OF MAGNETIC FIELD LEVELS

Appendices AG, AH and AI contain the figures of the magnetic field plots for the substation case. Appendices AB and AC contain the plots for the two datasets taken at the autotransformer site.

As previously mentioned, the major source of magnetic fields is the current carried by the equipment and structures inside the substation or autotransformer yards. Tables 7-4 through 7-6 summarize the statistics of the data of the three locations, namely outside the substation, inside the substation control house and

TABLE 7-4.

SUMMARY STATISTICS OF COMBINED VERTICAL DATASETS MEASURED AT THE GAULT ST. DENIS SUBSTATION 2 m (6.6 ft) FROM THE FENCE (DATASETS TGV032 AND 33)

TGV032, TGV033 - BEHIND GAULT ST. DENIS SUBSTATION					TOTAL OF 44 SAMPLES	
FREQUENCY BAND	HEIGHT ABOVE GROUND (cm)	MINIMUM MAGNETIC FIELD (mG)	MAXIMUM MAGNETIC FIELD (mG)	AVERAGE MAGNETIC FIELD (mG)	STANDARD DEVIATION (mG)	COEFFICIENT OF VARIATION (%)
STATIC	10	434.47	435.64	435.19	0.30	0.07
	60	436.67	438.37	437.52	0.44	0.10
	110	420.81	423.42	421.92	0.68	0.16
	160	455.44	457.95	456.60	0.53	0.12
5-45Hz LOW FREQ	10	0.10	0.89	0.25	0.12	46.85
	60	0.13	0.86	0.21	0.11	55.71
	110	0.04	0.82	0.16	0.12	76.29
	160	0.13	0.87	0.21	0.12	55.05
50-60Hz PWR FREQ	10	0.22	8.69	4.84	1.77	36.60
	60	0.22	8.83	4.94	1.81	36.72
	110	0.34	8.29	4.86	1.79	36.82
	160	0.22	8.99	5.21	1.87	35.99
65-300Hz PWR HARM	10	0.13	0.55	0.33	0.09	26.57
	60	0.15	0.55	0.33	0.09	25.71
	110	0.19	0.56	0.34	0.08	23.43
	160	0.18	0.55	0.36	0.08	22.98
305-2560Hz HIGH FREQ	10	0.05	0.55	0.32	0.09	27.46
	60	0.05	0.53	0.33	0.09	26.95
	110	0.05	0.51	0.32	0.08	26.16
	160	0.05	0.53	0.34	0.09	26.14
5-2560Hz ALL FREQ	10	0.38	8.71	4.88	1.75	35.93
	60	0.30	8.85	4.97	1.80	36.21
	110	0.40	8.31	4.89	1.78	36.33
	160	0.32	9.01	5.24	1.86	35.43

TABLE 7-5.

SUMMARY STATISTICS OF VERTICAL DATASET MEASURED AT THE GAULT ST. DENIS SUBSTATION
INSIDE THE CONTROL HOUSE (DATASET TGV034)

TGV034 - IN CONTROL HOUSE AT GAULT ST. DENIS SUBSTATION TOTAL OF 68 SAMPLES						
FREQUENCY BAND	HEIGHT ABOVE FLOOR (cm)	MINIMUM MAGNETIC FIELD (mG)	MAXIMUM MAGNETIC FIELD (mG)	AVERAGE MAGNETIC FIELD (mG)	STANDARD DEVIATION (mG)	COEFFICIENT OF VARIATION (%)
STATIC	10	343.58	345.17	344.27	0.36	0.10
	110	344.48	346.00	345.18	0.36	0.10
	160	356.74	358.07	357.40	0.27	0.08
5-45Hz LOW FREQ	10	0.12	0.65	0.32	0.12	39.38
	110	0.11	0.79	0.28	0.16	56.40
	160	0.44	0.89	0.55	0.10	18.74
50-60Hz PWR FREQ	10	1.43	26.05	8.91	6.37	71.50
	110	1.77	28.66	10.69	6.91	64.68
	160	2.10	34.26	12.95	8.38	64.67
65-300Hz PWR HARM	10	0.20	1.48	0.49	0.33	66.84
	110	0.28	1.65	0.67	0.34	50.30
	160	0.39	2.10	0.84	0.43	50.81
305-2560Hz HIGH FREQ	10	0.16	1.03	0.41	0.22	53.62
	110	0.31	1.17	0.74	0.16	21.41
	160	0.28	1.50	0.65	0.31	47.12
5-2560Hz ALL FREQ	10	1.50	26.12	8.94	6.38	71.32
	110	1.96	28.74	10.75	6.90	64.14
	160	2.22	34.37	13.01	8.38	64.37

TABLE 7-6.

SUMMARY STATISTICS OF COMBINED VERTICAL DATASETS MEASURED AT THE CHAILLOT AUTOTRANSFORMER STATION 2 m (6.6 ft) FROM THE FENCE (DATASETS TGV027 AND 28)

TGV027, TGV028 - CHAILLOT AUTO-TRANSFORMER					TOTAL OF 48 SAMPLES	
FREQUENCY BAND	HEIGHT ABOVE GROUND (cm)	MINIMUM MAGNETIC FIELD (mG)	MAXIMUM MAGNETIC FIELD (mG)	AVERAGE MAGNETIC FIELD (mG)	STANDARD DEVIATION (mG)	COEFFICIENT OF VARIATION (%)
STATIC	10	436.81	438.55	437.84	0.33	0.08
	60	442.17	443.05	442.60	0.22	0.05
	110	440.70	444.98	441.51	0.62	0.14
	160	453.44	458.56	456.07	1.27	0.28
5-45Hz LOW FREQ	10	0.11	0.36	0.24	0.06	25.38
	60	0.12	0.27	0.16	0.04	27.04
	110	0.06	0.25	0.13	0.05	42.55
	160	0.13	0.30	0.18	0.05	27.13
50-60Hz PWR FREQ	10	0.11	11.79	3.22	3.24	100.77
	60	0.14	11.81	3.33	3.36	100.94
	110	0.18	12.24	3.47	3.50	100.97
	160	0.14	12.57	3.70	3.67	99.32
65-300Hz PWR HARM	10	0.04	0.64	0.23	0.16	72.50
	60	0.06	0.65	0.24	0.16	68.14
	110	0.08	0.68	0.27	0.15	56.10
	160	0.11	0.69	0.28	0.16	58.88
305-2560Hz HIGH FREQ	10	0.03	0.53	0.19	0.14	72.66
	60	0.04	0.54	0.20	0.14	72.77
	110	0.04	0.55	0.20	0.15	72.63
	160	0.04	0.56	0.21	0.15	71.06
5-2560Hz ALL FREQ	10	0.27	11.81	3.27	3.23	98.83
	60	0.20	11.83	3.36	3.36	99.92
	110	0.25	12.26	3.50	3.50	99.97
	160	0.23	12.58	3.73	3.67	98.14

outside the autotransformer yard. Each table shows the minimum, maximum and average field levels, as well as the standard deviation and coefficient of variation. The results are summarized by the same set of five frequency ranges used throughout this report, and by the height above ground, as given by the four sensor locations mounted on the staff.

Table 7-4 has the overall statistics of the combined datasets TGV032 and TGV033, taken outside the substation yard. The maximum reading of 8.99 mG occurred in the power frequency range, at the 160 cm height. However the difference between the maxima of all four heights is less than 8%.

Table 7-5 has the overall statistics of the TGV034 dataset, taken inside the substation control house. The 60 cm data were omitted because of the possibility of some erroneous readings due to the waveform capture system autoranging (a built-in feature of the waveform capture system to automatically adjust any specific sensor range to an optimum value). The maximum reading of 34.26 mG occurred in the power frequency range, at the 160 cm height. The difference between the maxima of all three heights is a substantial 24%. The corresponding difference of the average values in the power frequency range is also a substantial 31%. This indicates that the source is closer to the top of the staff, as is the case inside the substation.

Table 7-6 has the overall statistics of the combined datasets TGV027 and TGV028, taken outside the autotransformer yard. The maximum reading of 12.57 mG occurred in the power frequency range, at the 160 cm height. The values show a positive, although small, gradient with vertical distance. The difference between the maxima of all four heights is less than 6%.

For the control house and the autotransformer data, the largest coefficient of variation is in the power frequency range. In all three cases, the coefficient of variation was smallest for the static frequency band.

7.7 SUMMARY OF ELECTRIC FIELD LEVELS

Electric field measurements were taken at both the substation and the autotransformer sites, perpendicular to the perimeter fence. As Figure 7-1 illustrates, there were two profiles taken at the substation: Profile 1 outward from the low voltage side and profile 2 outward from the high voltage side. Figure 7-2 shows the location of the profile outside the autotransformer yard. Both the data collected along these profiles and the resultant plots are included in this section of the report.

Figures 7-6 and 7-7 show the profiles of electric field strength measured outside the Gault St. Denis Substation. The highest electric field is on the end of the substation near the high voltage yard, as shown in Figure 7-7. The electric field on the side of the substation which faces away from the tracks (Figure 7-6) is considerably lower than that near the 220 kV high voltage yard. Values are comparable to the low voltage side of the substation.

Figure 7-8 shows the results of the electric field measurement, in volts per meter, outside the autotransformer yard. The electric field values here are comparable to those along the side of the substation facing away from the tracks.

ELECTRIC FIELD AT SUBSTATION

Profile 1 - Low Voltage Side

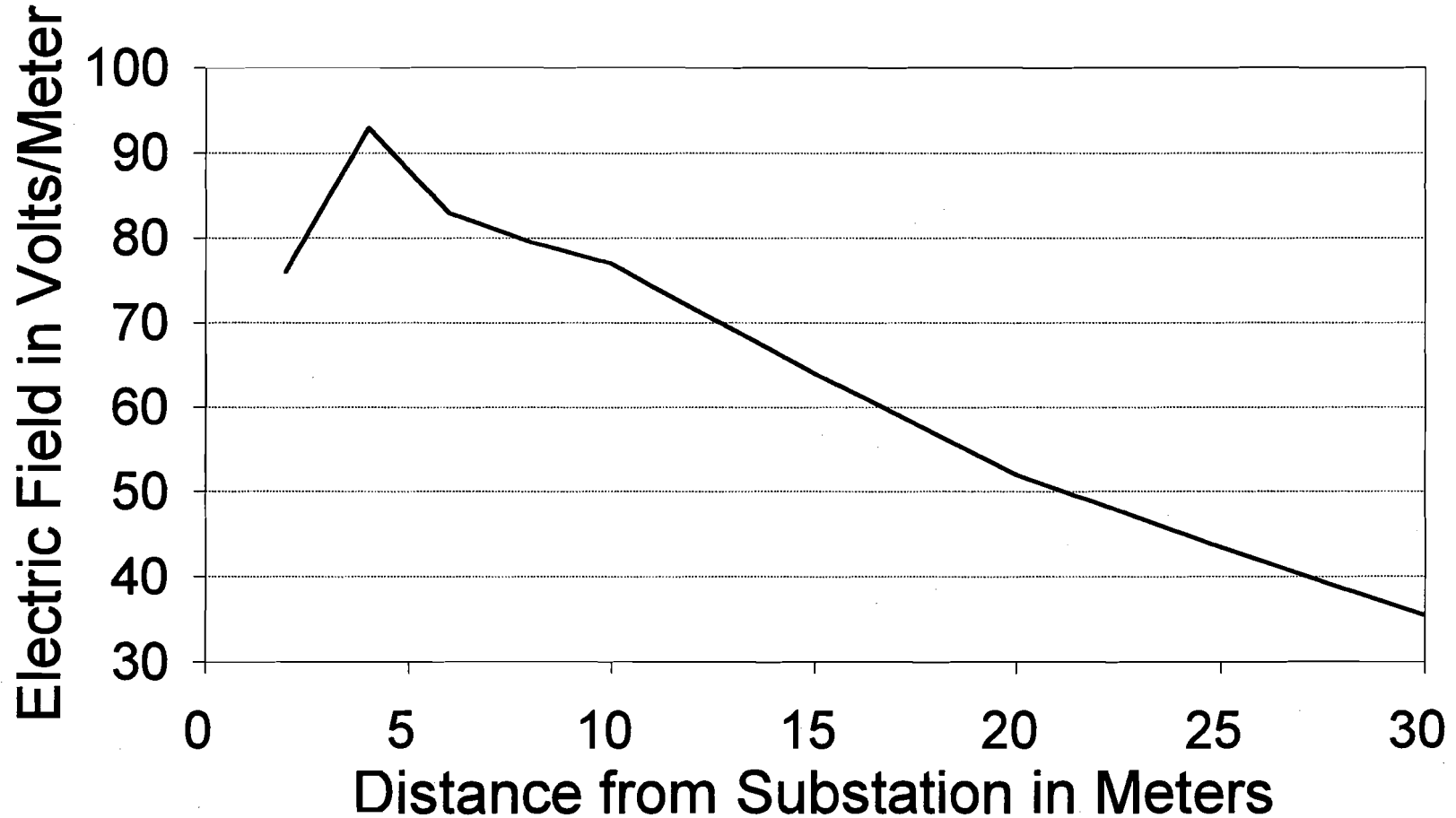

7-17

FIGURE 7-6.

PROFILE OF ELECTRIC FIELD LEVEL NEAR THE GAULT ST. DENIS SUBSTATION ON THE LOW VOLTAGE SIDE, AS A FUNCTION OF PERPENDICULAR DISTANCE FROM THE FENCE

ELECTRIC FIELD AT SUBSTATION

Profile 2 - High Voltage Side

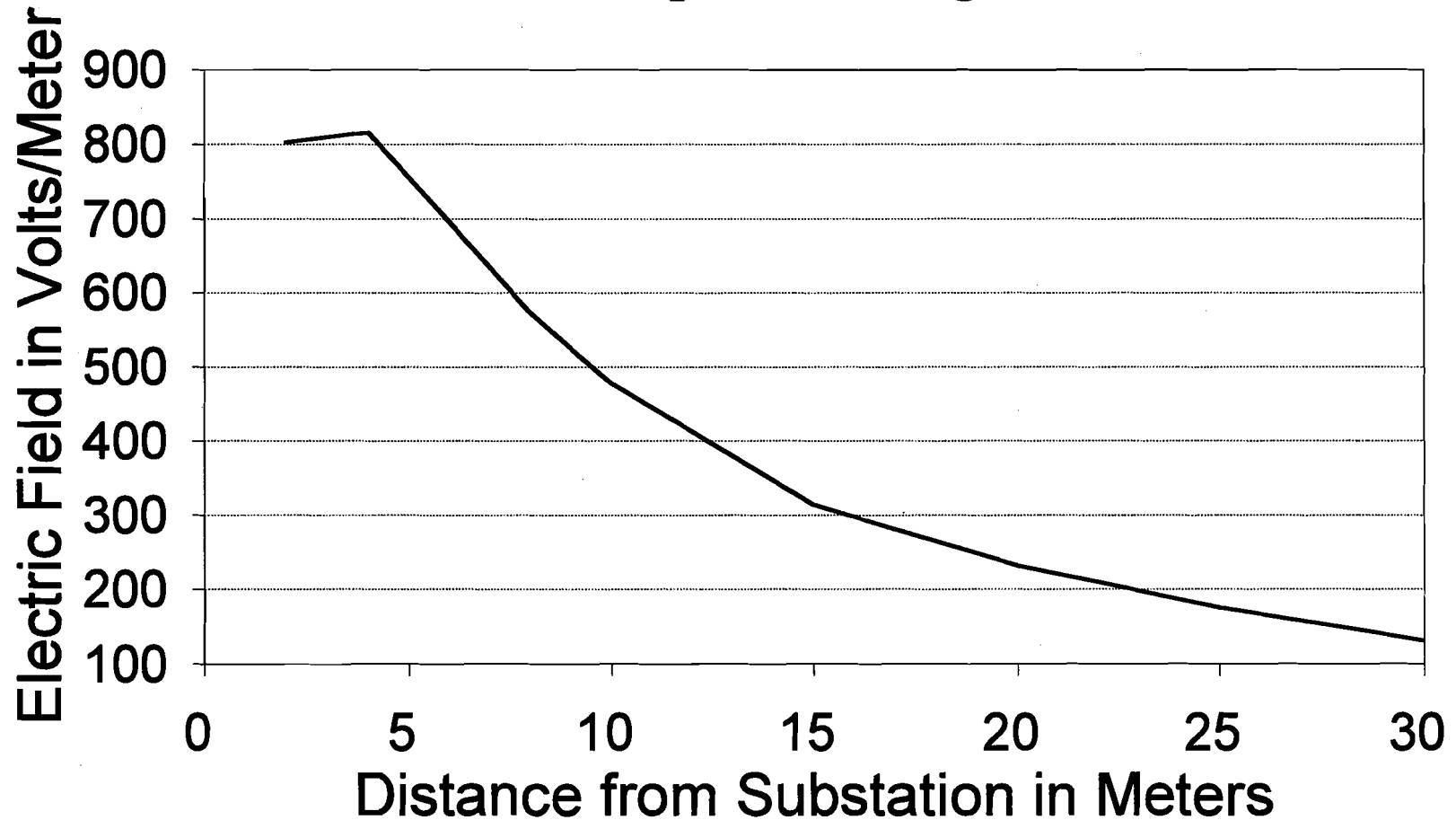

7-18

FIGURE 7-7.

PROFILE OF ELECTRIC FIELD LEVEL NEAR THE GAULT ST. DENIS SUBSTATION ON THE HIGH VOLTAGE SIDE, AS A FUNCTION OF PERPENDICULAR DISTANCE FROM THE FENCE

ELECTRIC FIELD AT AUTOTRANSFORMER

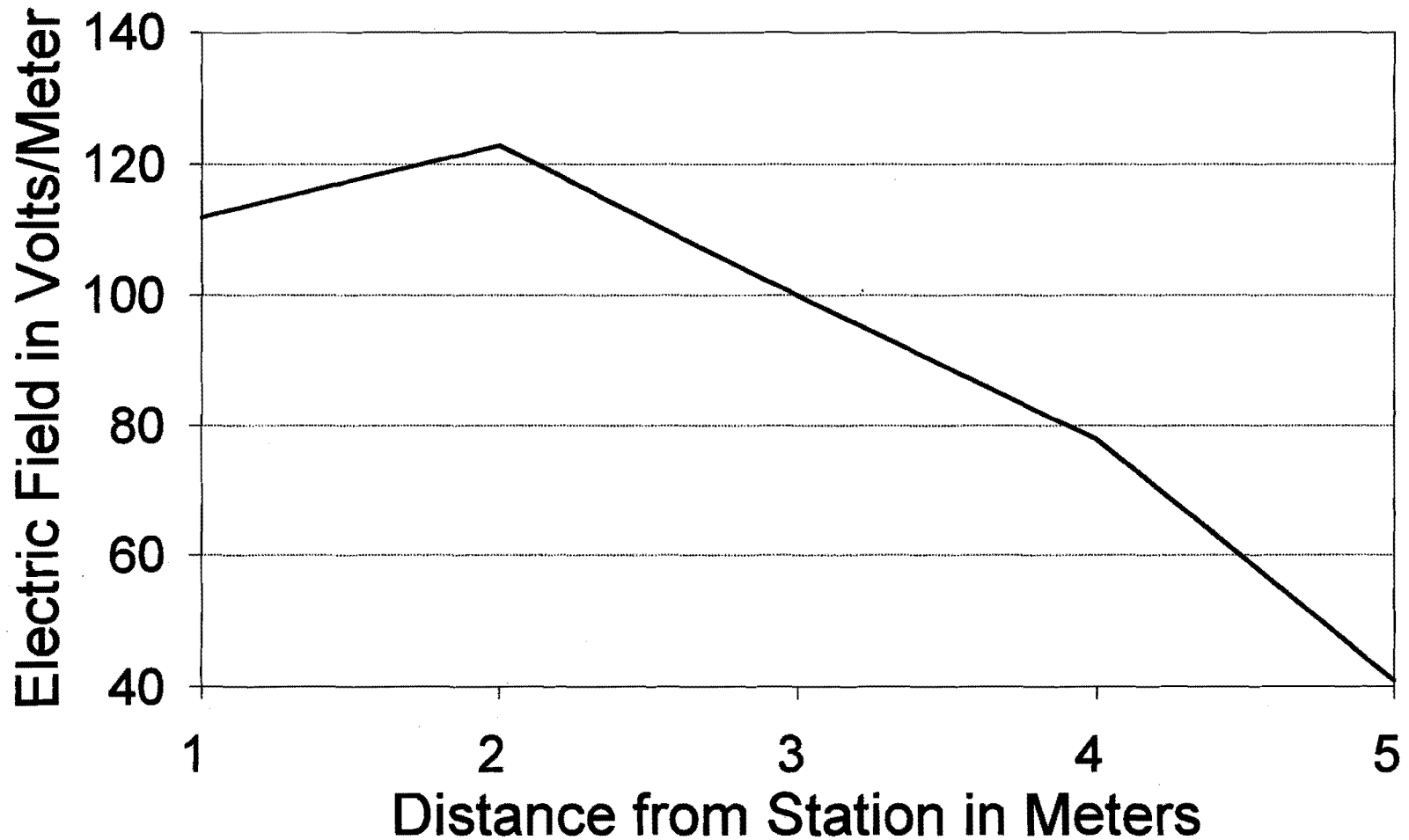

7-19/7-20

FIGURE 7-8. PROFILE OF ELECTRIC FIELD LEVEL NEAR THE CHAILLOT AUTOTRANSFORMER STATION, AS A FUNCTION OF PERPENDICULAR DISTANCE FROM THE FENCE

8. MEASUREMENTS AT TRAFFIC CONTROL FACILITIES

This section reports on the magnetic fields recorded in two control facilities' environments. They are the TGV-A Control Center and a Relay Room at the Vendome Station. These environments represent locations where railroad workers may encounter magnetic fields from electric power sources other than the railroad electrical traction system.

8.1 MEASUREMENT LOCATIONS

Figure 8-1 shows the layout of the TGV-A Control Center at Gare Montparnasse in Paris. As shown in the figure, there were two sets of fixed position, extended time measurements at the dispatcher's work station. One was a vertical profile measurement at the right rear corner of the dispatcher's seat (Location # 10 on the figure). Those data constitute dataset TGV010. The second measurement in the dispatcher's area (TGV011) was a horizontal profile measured with one end of the staff placed against the screen of the central monitor, 90 cm from the floor. Both sets of data were collected between 10:50 and 10:54 on September 8, 1992. The reference probe was placed on the dispatcher's chair during both the horizontal and vertical profile measurements.

Figure 8-2 shows the Relay Room at the Vendome station, which measures approximately 10 by 15 m (33 by 49 ft). Two sets of measurement were taken: one near the ac supply cabinet (TGV015) and one in the middle of the relay racks (TGV016). Measurements were taken on September 8, 1992 from 15:09 to 15:17.

8.2 REPETITIVE WAVEFORM DATASETS

The four repetitive waveform datasets that are associated with the Control and Relay room measurements are shown in Table 8-1. The data was recorded with the repetitive field waveform monitoring system. This table summarizes the pertinent information about these datasets, including the number of samples and sampling interval.

Appendices K, L, P and Q contain the figures of the four datasets shown in the table. These figures show three-dimensional graphs of the magnetic fields as functions of frequency, time and distance. These plots are similar to the plots used throughout this report.

TGV Control Center
in Paris (Montparnasse Station)

8-2

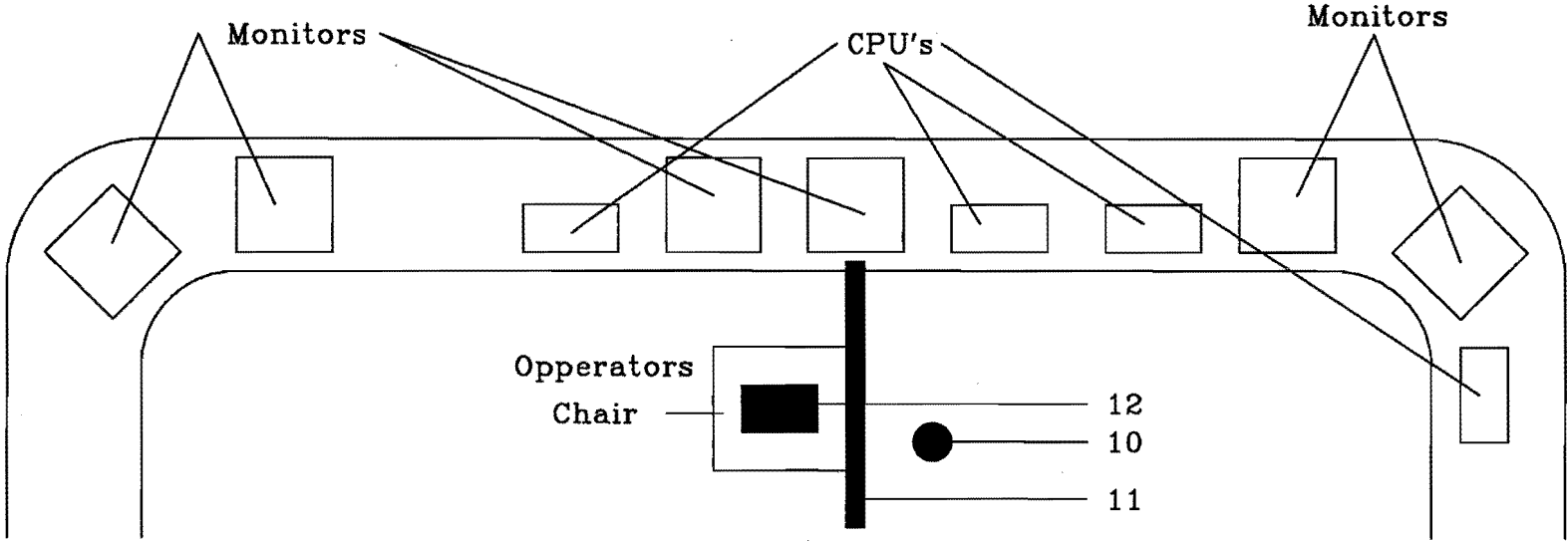

FIGURE 8-1. REPETITIVE WAVEFORM MEASUREMENT LOCATIONS INSIDE THE TGV-A CONTROL CENTER AT GARE MONTPARNASSE

Relay Room Vendôme Station

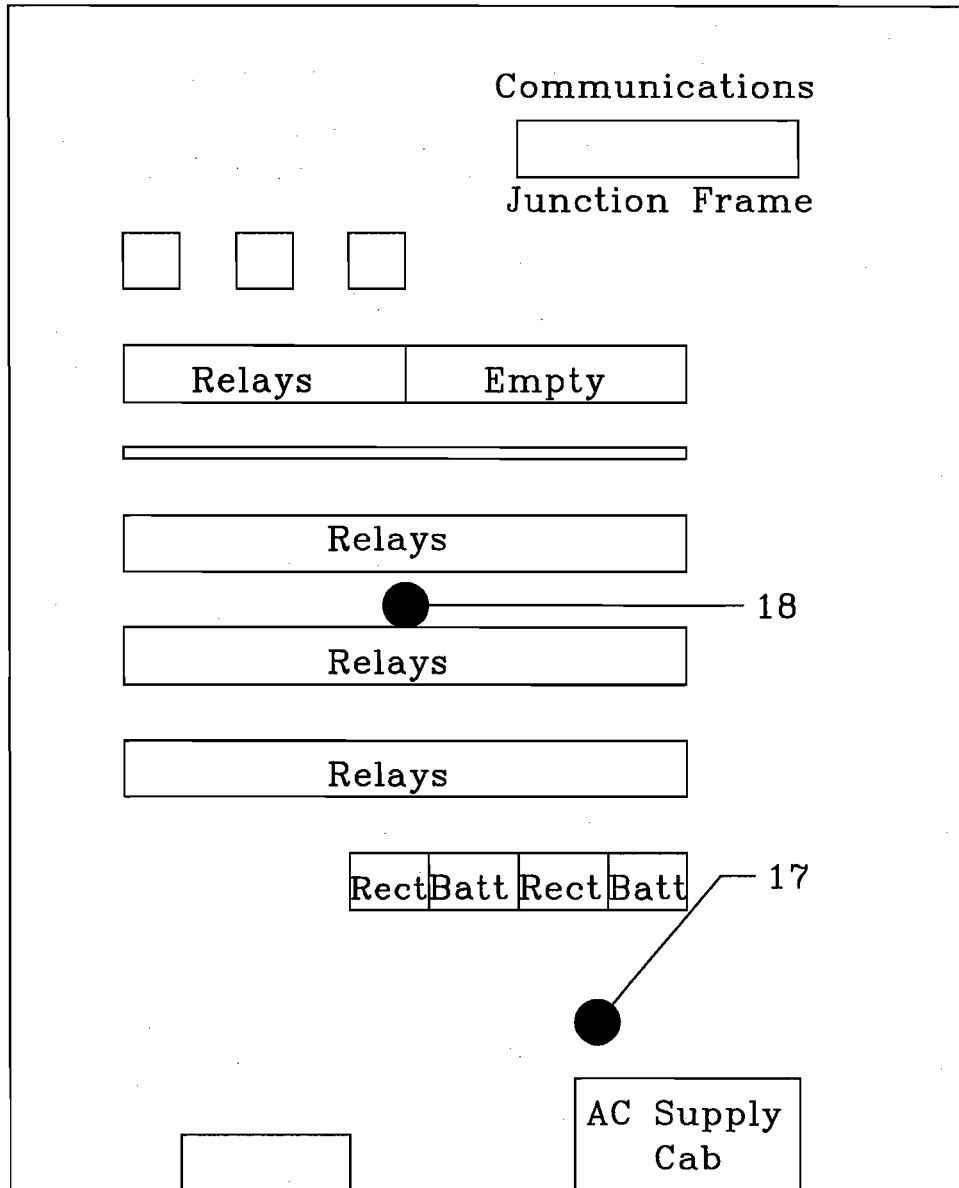

FIGURE 8-2. REPETITIVE WAVEFORM MEASUREMENT LOCATIONS INSIDE THE RELAY ROOM AT VENDOME

TABLE 8-1.

REPETITIVE MAGNETIC FIELD WAVEFORM DATASETS
MEASURED IN CONTROL FACILITIES

DATA FILE NUMBER	DATE/TIME	LOCATION FIG. # STAFF/REF.	# OF SAMPLES & RATE	APPENDIX	REMARKS
TGV010	SEP. 8 10:50-10:51	8-1 10/12	10 10 SEC	K	TGV-A CTRL. STAFF POS. VERTICAL
TGV011	SEP. 8 10:52-10:54	8-1 11/12	10 10 SEC	L	TGV-A CTRL. STAFF POS. HORIZONTAL
TGV015	SEP. 8 15:09-15:11	8-2 17	12 10 SEC	P	RELAY ROOM AC SUPPLY CABINETS
TGV016	SEP. 8 15:15-15:17	8-2 18	12 10 SEC	Q	RELAY ROOM RELAY CABINETS

8.3 FIELD SOURCE IDENTIFICATION

This study measured the magnetic fields inside the control room, near the computer monitors. Control room ELF magnetic fields appear to arise mainly from two sources: the video display monitors on the dispatcher's console, and electrical wiring and equipment within the building.

Figure 8-3 is the TGV010 dataset plot of the 10 cm data from the floor. As it can be seen, there is very little temporal variation in the frequency components present. The static magnetic field is constant and about one half the unperturbed geomagnetic field. The frequency components are the 50 Hz fundamental and its odd harmonics. The values are relatively small, around a milligauss or so, which is a typical value for the magnetic fields within buildings resulting from building wiring, lights, and remote from electrical apparatus. The field level 10 cm above the floor is larger than the rest of the measures, indicating some contribution from possible house wiring in the floor, or the ceiling of the floor below.

The horizontal profile measurements (TGV011) reported in Appendix L show that the vertical deflection circuits within the video monitors also contribute to the magnetic field environment at the dispatcher's seat as evidenced by the high harmonic content of the

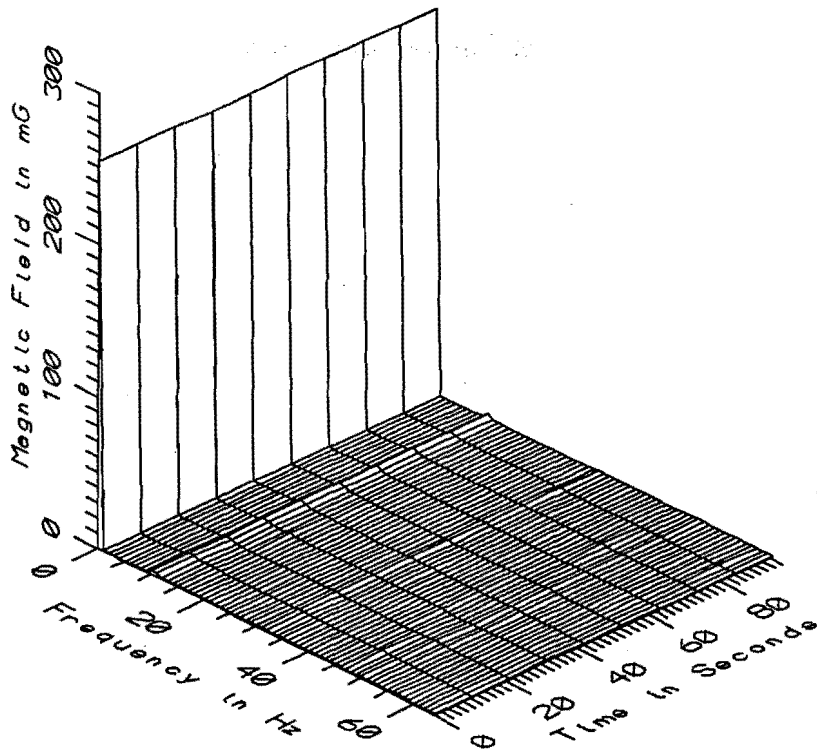

TGV010 - 10cm ABOVE FLOOR NEAR CONSOLE IN TGV CONTROL CENTER

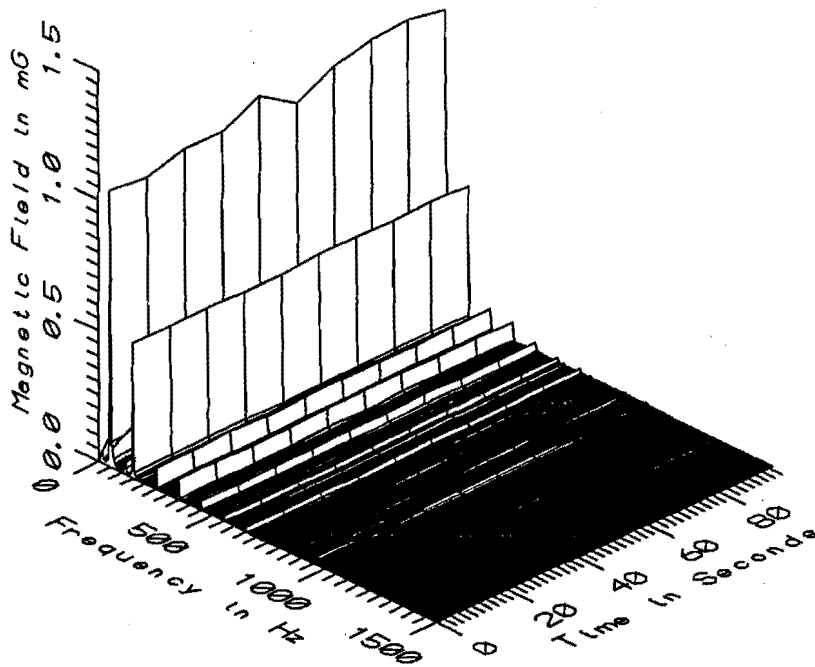

TGV010 - 10cm ABOVE FLOOR NEAR CONSOLE IN TGV CONTROL CENTER

FIGURE 8-3. MAGNETIC FIELD LEVEL, WITH AND WITHOUT THE STATIC COMPONENT, AT 10 cm HEIGHT ABOVE THE FLOOR AND IN FRONT OF THE CENTERMOST MONITOR SCREEN INSIDE THE TGV-A CONTROL CENTER AT GARE MONTPARNASSE, AS A FUNCTION OF FREQUENCY AND TIME

sawtooth deflection field and the clear attenuation pattern away from the monitors.

Figure 8-4 is the TGV015 dataset plot of the 110 cm height data, inside the Relay Room. As in the case of the TGV-A Control room, the main components of the field are the 50 Hz fundamental and its odd harmonics. The field is relatively constant with time and relatively small in intensity. Also, the field values are independent of height. The maximum value of this dataset was 2.81 mG at the 60 cm height. These fields appear to originate from the ac and dc power supply equipment in the rack adjacent to the measurement location. Magnetic field measurements in the center of the room among the relay racks show slightly less than one half the earth's magnetic field. The 50 Hz component of the field is near 0.5 mG and relatively uniform, suggesting that the source is general building wiring or some other relatively distant source.

8.4 DAT WAVEFORM DATA

Continuous recordings of the magnetic field at the reference probe located in the dispatcher's seat were made with the DAT while the vertical and horizontal profile measurements were being made in the TGV-A control room. The ELF magnetic field level was nearly constant on magnitude, as indicated in Table 8-2. The magnetic field waveform recorded by the DAT was characteristic of that produced by video display terminals. As mentioned, the video display terminals on the dispatcher's console were perhaps the most significant magnetic field source in the immediate area of the measurements. The DAT recording gave no indication of significant transient magnetic fields or high intensity, short duration fields which might escape detection by the more spatially comprehensive repetitive waveform measurements.

DAT recordings were not made in the Vendome relay room.

TABLE 8-2.

**SUMMARY OF MAGNETIC FIELD LEVELS RECORDED
AT THE DISPATCHER'S SEAT
INSIDE THE TGV-A CONTROL CENTER AT GARE MONTPARNASSE
WITH THE DIGITAL AUDIO TAPE RECORDER (DAT)**

(DATASETS)	MEASUREMENT LOCATION		MAGNETIC FIELD MILLIGAUSS, RMS		
	FIGURE #	LOCATION	MINIMUM	AVERAGE	MAXIMUM
(2-1)	8-1	12	2.1	2.16	2.3

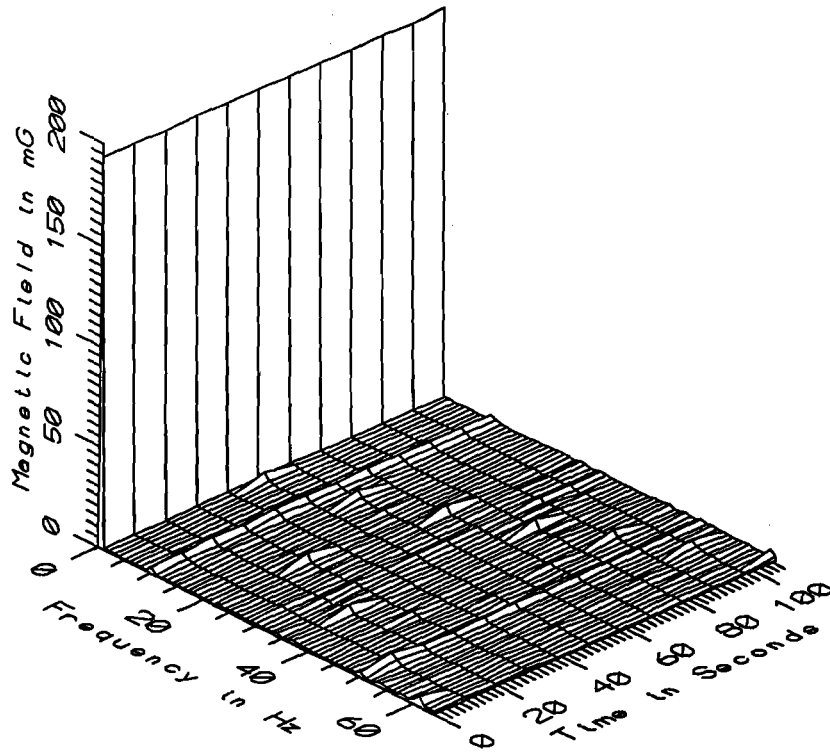

TGV015 - 110cm ABOVE FLOOR NEAR AC SUPPLY CABINET IN VENDOME RELAY ROOM

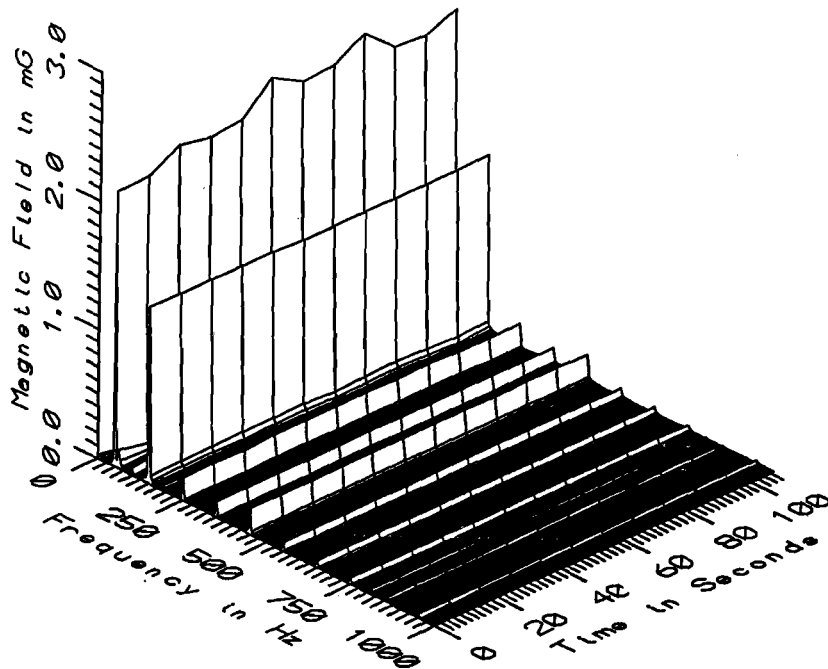

TGV015 - 110cm ABOVE FLOOR NEAR AC SUPPLY CABINET IN VENDOME RELAY ROOM

FIGURE 8-4. MAGNETIC FIELD LEVEL, WITH AND WITHOUT THE STATIC COMPONENT, AT 110 cm HEIGHT ABOVE THE FLOOR NEAR THE AC SUPPLY CABINET INSIDE THE RELAY ROOM AT VENDOME, AS A FUNCTION OF FREQUENCY AND TIME

8.5 SUMMARY OF MAGNETIC FIELD LEVELS

Appendices K and L contain the figures of the magnetic field plots for the TGV-A Control Room case. Appendices P and Q contain the plots for the two datasets taken at the Vendome Relay Room.

The major sources of magnetic fields are the current in the building wiring, vertical deflection coils in the video display terminals, and power supplies for relays and other electronic apparatus. Tables 8-3 through 8-7 summarize the statistics of the data of the various control facility measurement locations. Each table shows the minimum, maximum and average field levels, as well as the standard deviation and coefficient of variation. The results are summarized by the same set of five frequency ranges used throughout this report, and by the height above ground (or the distance from the monitor screen, as in the case of dataset TGV011), given by the four sensor locations mounted on the staff.

Table 8-3 gives the statistics of dataset TGV010 in the Traffic Control Room. The maximum reading of 1.19 mG occurred in the power frequency range, at the 10 cm height.

Table 8-4 gives the statistics of dataset TGV011 in the Traffic Control Room. The maximum reading of 5.71 mG occurred in the power harmonics frequency range, at the 10 cm distance from the screen. Note that the harmonics are higher than the fundamental near the screen where the deflection yoke is the primary magnetic field source. This phenomenon does not appear at the other distances because the field at those locations arise from both the video display terminals and the general 50 Hz field sources such as building wiring.

Table 8-5 gives the statistics of dataset TGV015 in the Relay Room. The maximum reading of 2.81 mG occurred in the power frequency range, at the 60 cm height. Since the staff was oriented vertically, all of the sensors were the same distance from the power supply cabinet. But apparently, the principal source within the cabinet was about 60 cm above the floor.

Table 8-6 gives the statistics of dataset TGV016 in the Relay Room. The maximum reading of 0.68 mG occurred in the power harmonics frequency range, at both ends of the staff, namely the 10 and 110 cm distances from the floor. The lack of detectable spatial gradient implies that the sources were probably distributed throughout the room or outside the room and were not the relay equipment near the measurement staff.

Table 8-7 has the overall statistics of both Relay Room datasets. The maximum reading of 2.81 mG occurred in the power frequency range, at the 60 cm height. The values do not show any appreciable gradient with vertical distance.

TABLE 8-3.

SUMMARY STATISTICS OF VERTICAL DATASET MEASURED IN THE TGV-A CONTROL CENTER AT GARE MONTPARNASSE IN FRONT OF THE CENTERMOST MONITOR SCREEN (DATASET TGV010)

TGV010 - TGV CONTROL CENTER, GARE MONTPARNASSE		TOTAL OF 10 SAMPLES				
FREQUENCY BAND	HEIGHT ABOVE FLOOR (cm)	MINIMUM MAGNETIC FIELD (mG)	MAXIMUM MAGNETIC FIELD (mG)	AVERAGE MAGNETIC FIELD (mG)	STANDARD DEVIATION (mG)	COEFFICIENT OF VARIATION (%)
STATIC	10	253.12	256.00	254.79	0.92	0.36
	60	431.48	433.69	432.64	0.62	0.14
	110	503.57	506.27	504.66	0.78	0.15
	160	509.71	512.14	510.56	0.79	0.16
5-45Hz LOW FREQ	10	0.11	0.36	0.23	0.11	48.27
	60	0.17	0.20	0.18	0.01	4.30
	110	0.07	0.14	0.10	0.03	25.73
	160	0.17	0.20	0.19	0.01	4.02
50-60Hz PWR FREQ	10	1.06	1.19	1.13	0.05	4.52
	60	0.55	0.63	0.59	0.03	4.27
	110	0.45	0.56	0.49	0.03	6.74
	160	0.46	0.54	0.49	0.03	5.57
65-300Hz PWR HARM	10	0.53	0.55	0.54	0.00	0.89
	60	0.52	0.54	0.53	0.00	0.78
	110	0.43	0.47	0.44	0.01	2.90
	160	0.43	0.44	0.43	0.00	1.08
305-2560Hz HIGH FREQ	10	0.09	0.11	0.10	0.00	4.53
	60	0.06	0.07	0.06	0.00	5.67
	110	0.05	0.06	0.06	0.00	6.11
	160	0.05	0.06	0.05	0.00	6.31
5-2560Hz ALL FREQ	10	1.20	1.36	1.28	0.05	4.15
	60	0.78	0.84	0.81	0.02	2.16
	110	0.64	0.72	0.67	0.03	3.98
	160	0.66	0.71	0.68	0.02	2.56

TABLE 8-4.

SUMMARY STATISTICS OF HORIZONTAL PROFILE DATASET MEASURED IN THE TGV-A CONTROL CENTER AT GARE MONTPARNASSE FROM THE CENTERMOST MONITOR SCREEN (DATASET TGV011)

TGV011 - TGV CONTROL CENTER, GARE MONTPARNASSE				TOTAL OF 10 SAMPLES		
FREQUENCY BAND	DIST. FROM CRT (cm)	MINIMUM MAGNETIC FIELD (mG)	MAXIMUM MAGNETIC FIELD (mG)	AVERAGE MAGNETIC FIELD (mG)	STANDARD DEVIATION (mG)	COEFFICIENT OF VARIATION (%)
STATIC	10	501.18	507.78	504.01	2.07	0.41
	60	560.21	564.84	562.76	1.56	0.28
	110	516.04	520.29	518.63	1.59	0.31
	160	492.40	496.14	494.39	0.97	0.20
5-45Hz LOW FREQ	10	0.31	0.78	0.56	0.12	21.40
	60	0.21	0.30	0.24	0.03	12.43
	110	0.07	0.14	0.11	0.03	23.25
	160	0.18	0.21	0.19	0.01	4.25
50-60Hz PWR FREQ	10	1.87	3.10	2.47	0.40	16.25
	60	0.85	1.07	0.98	0.06	6.35
	110	0.44	0.63	0.53	0.06	11.39
	160	0.52	0.59	0.56	0.02	3.51
65-300Hz PWR HARM	10	2.38	5.71	4.25	0.97	22.75
	60	0.59	0.69	0.65	0.03	4.49
	110	0.45	0.47	0.46	0.01	1.87
	160	0.55	0.57	0.56	0.01	1.45
305-2560Hz HIGH FREQ	10	2.81	3.75	3.47	0.29	8.35
	60	0.22	0.25	0.23	0.01	3.90
	110	0.07	0.08	0.08	0.00	5.29
	160	0.04	0.06	0.05	0.00	8.00
5-2560Hz ALL FREQ	10	4.16	7.52	6.07	0.94	15.48
	60	1.13	1.29	1.22	0.05	3.96
	110	0.65	0.80	0.71	0.05	6.72
	160	0.79	0.84	0.82	0.01	1.72

TABLE 8-5.

SUMMARY STATISTICS OF VERTICAL DATASET MEASURED IN THE RELAY ROOM AT VENDOME NEAR THE AC SUPPLY CABINET (DATASET TGV015)

TGV015 - VENDOME RELAY ROOM, NEAR AC SUPPLY CABINET					TOTAL OF 12 SAMPLES	
FREQUENCY BAND	HEIGHT ABOVE FLOOR (cm)	MINIMUM MAGNETIC FIELD (mG)	MAXIMUM MAGNETIC FIELD (mG)	AVERAGE MAGNETIC FIELD (mG)	STANDARD DEVIATION (mG)	COEFFICIENT OF VARIATION (%)
STATIC	10	350.67	351.26	350.97	0.22	0.06
	60	207.05	207.79	207.45	0.24	0.12
	110	192.74	193.79	193.33	0.36	0.19
	160	289.08	290.45	289.71	0.47	0.16
5-45Hz LOW FREQ	10	0.12	0.37	0.24	0.08	34.29
	60	0.16	0.20	0.17	0.01	7.31
	110	0.05	0.17	0.10	0.04	34.75
	160	0.17	0.21	0.18	0.01	5.48
50-60Hz PWR FREQ	10	2.29	2.40	2.36	0.03	1.24
	60	2.54	2.81	2.67	0.09	3.40
	110	2.14	2.52	2.32	0.12	4.97
	160	2.03	2.22	2.14	0.06	2.96
65-300Hz PWR HARM	10	0.95	0.98	0.96	0.01	1.06
	60	1.02	1.05	1.03	0.01	0.92
	110	1.38	1.40	1.39	0.01	0.42
	160	1.74	1.77	1.76	0.01	0.62
305-2560Hz HIGH FREQ	10	0.16	0.17	0.16	0.00	1.47
	60	0.21	0.22	0.21	0.00	1.50
	110	0.27	0.28	0.27	0.00	1.36
	160	0.37	0.38	0.37	0.00	1.04
5-2560Hz ALL FREQ	10	2.50	2.61	2.57	0.03	1.23
	60	2.75	3.00	2.87	0.09	2.97
	110	2.57	2.90	2.72	0.10	3.69
	160	2.72	2.87	2.80	0.05	1.75

TABLE 8-6.

SUMMARY STATISTICS OF VERTICAL DATASET MEASURED IN THE RELAY ROOM AT VENDOME BETWEEN THE RELAY CABINETS (DATASET TGV016)

TGV016 - VENDOME RELAY ROOM, BETWEEN RELAY SHELVES					TOTAL OF 12 SAMPLES	
FREQUENCY BAND	HEIGHT ABOVE FLOOR (cm)	MINIMUM MAGNETIC FIELD (mG)	MAXIMUM MAGNETIC FIELD (mG)	AVERAGE MAGNETIC FIELD (mG)	STANDARD DEVIATION (mG)	COEFFICIENT OF VARIATION (%)
STATIC	10	332.94	333.74	333.34	0.26	0.08
	60	286.72	287.80	287.14	0.32	0.11
	110	359.53	361.10	359.92	0.41	0.11
	160	462.42	464.14	463.31	0.53	0.11
5-45Hz LOW FREQ	10	0.25	0.50	0.35	0.08	22.19
	60	0.21	0.38	0.31	0.06	18.84
	110	0.37	0.48	0.42	0.04	9.52
	160	0.31	0.42	0.35	0.03	8.04
50-60Hz PWR FREQ	10	0.24	0.68	0.39	0.15	39.89
	60	0.19	0.47	0.32	0.10	30.48
	110	0.17	0.50	0.30	0.11	37.80
	160	0.25	0.68	0.42	0.15	36.98
65-300Hz PWR HARM	10	0.36	0.43	0.39	0.02	4.78
	60	0.32	0.35	0.34	0.01	3.40
	110	0.28	0.34	0.32	0.02	5.24
	160	0.34	0.40	0.38	0.02	4.49
305-2560Hz HIGH FREQ	10	0.99	1.05	1.03	0.02	1.90
	60	0.93	1.01	0.97	0.02	2.20
	110	0.81	0.89	0.85	0.02	2.61
	160	1.07	1.12	1.09	0.01	1.22
5-2560Hz ALL FREQ	10	1.18	1.33	1.23	0.05	3.95
	60	1.09	1.19	1.12	0.03	2.69
	110	0.95	1.16	1.05	0.06	6.05
	160	1.23	1.37	1.29	0.05	3.60

TABLE 8-7.

SUMMARY STATISTICS OF COMBINED VERTICAL DATASETS MEASURED IN THE RELAY ROOM AT VENDOME (DATASETS TGV015 AND 16)

TGV015, TGV016 - VENDOME RELAY ROOM, ALL SAMPLES				TOTAL OF 24 SAMPLES		
FREQUENCY BAND	HEIGHT ABOVE FLOOR (cm)	MINIMUM MAGNETIC FIELD (mG)	MAXIMUM MAGNETIC FIELD (mG)	AVERAGE MAGNETIC FIELD (mG)	STANDARD DEVIATION (mG)	COEFFICIENT OF VARIATION (%)
STATIC	10	332.94	351.26	342.16	9.01	2.63
	60	207.05	287.80	247.29	40.70	16.46
	110	192.74	361.10	276.63	85.09	30.76
	160	289.08	464.14	376.51	88.67	23.55
5-45Hz LOW FREQ	10	0.12	0.50	0.30	0.10	32.50
	60	0.16	0.38	0.24	0.08	33.51
	110	0.05	0.48	0.26	0.16	63.53
	160	0.17	0.42	0.27	0.09	33.51
50-60Hz PWR FREQ	10	0.24	2.40	1.37	1.02	73.94
	60	0.19	2.81	1.49	1.20	80.74
	110	0.17	2.52	1.31	1.04	79.10
	160	0.25	2.22	1.28	0.89	69.46
65-300Hz PWR HARM	10	0.36	0.98	0.67	0.29	43.18
	60	0.32	1.05	0.69	0.36	51.78
	110	0.28	1.40	0.86	0.55	63.76
	160	0.34	1.77	1.07	0.70	66.03
305-2560Hz HIGH FREQ	10	0.16	1.05	0.60	0.44	73.96
	60	0.21	1.01	0.59	0.39	65.21
	110	0.27	0.89	0.56	0.29	52.29
	160	0.37	1.12	0.73	0.37	50.33
5-2560Hz ALL FREQ	10	1.18	2.61	1.90	0.69	36.14
	60	1.09	3.00	2.00	0.90	44.83
	110	0.95	2.90	1.88	0.86	45.68
	160	1.23	2.87	2.04	0.77	37.93

9. CONCLUSIONS

Sections 3.0 through 8.0 of this report present the results and analysis of extensive measurements of magnetic and electric fields within the coaches and locomotives, along the wayside, at passenger stations, near electric power supply stations and inside control facilities of the TGV-A rail system in France.

As described in these sections, the time varying magnetic fields at most locations on the trains, the platforms, or along the wayside arise predominantly from current in the catenary, feeder circuit and track. The power distribution within the trains consists of conductors in the roof and under the floor in the coaches and locomotives. Because power needs of the locomotive are set by both terrain and speed control, these fields are highly variable over time. The odd harmonics of the power frequency magnetic field follow the same temporal variation.

The static magnetic field at all outside locations is the natural geomagnetic field of the earth. However, the static field inside the coaches and locomotive is highly variable while the train is operating in the dc portion of the track.

Significant electric fields were detected only outside electrical power delivery equipment installations, such as substations and autotransformers and at the wayside. The higher levels occurred closest to the substation high voltage lines. No significant electric fields were detected inside the locomotive or the coaches, as expected, because of the shielding by the train metallic bodies.

9.1 SUMMARY OF TGV-A FIELD LEVELS

This subsection provides a concise description of the field characteristics at each of the areas examined.

9.1.1 Coaches

The magnetic fields in coaches arise mainly from the current required for traction power which flows in the overhead catenary, the track, and the 25 kV ac single phase cable in the roof of the coaches. There are hotel power cables, both ac and dc, that interconnect the coaches. A 1500 Volt dc cable under the coaches interconnects the push-pull locomotives during dc track operation.

The major component of the magnetic field when the train is traveling on the dc portion of the route is principally static or near static. It arises from current in the overhead catenary, tracks, and a power cable beneath the coaches which interconnects the locomotives. The static magnetic field in the dc powered section of the line, as measured by the waveform capture system,

averaged 913 mG over all samples and all sensor locations. The maximum static field encountered during the same periods was 3066 mG.

The 50 Hz power frequency component of the magnetic field was the principal component in the coaches while the train is in the ac powered section of the line. It averaged 31 mG over all samples and all sensor locations. There is also a substantial low frequency (5-45 Hz) magnetic field component which averages 23 mG throughout the coaches. The maximum ac magnetic field encountered during the same periods was 165 mG.

Overall, the magnetic field was relatively uniform throughout the coaches and had frequency components consistent with the main power supply frequency and its harmonics. The electric fields detected inside the coaches were on the order of 0.1 V/m.

9.1.2 Locomotive (Power Car) Cabs

The principal source of magnetic field in the engineer's cab is the current in the catenary and track circuit, augmented by fields from current circuits passing through the locomotive, such as the 25 kV cabling, circuit breaker and transformer connections. The following summary values are obtained close to the engineer's seat.

The static magnetic field in the dc powered sections of the track averaged 815 mG over all samples and all sensor locations. The maximum static field encountered during the same periods was 2580 mG.

The magnetic fields in the power frequency sub-band measured in the ac powered sections of the track averaged 87 mG over all samples and all sensor locations. The maximum ac magnetic field encountered during the same periods was 367 mG. The magnetic field of the power frequency band is relatively spatially uniform from side to side but shows a strong consistent spatial gradient in the axial direction.

Overall, the magnetic field had frequency components consistent with the main power supply frequency and its harmonics.

The electric fields detected inside the locomotives were less than 1 V/m for the power frequency range.

9.1.3 Railroad Waysides

The magnetic field at the wayside of electrified railroads arises almost exclusively from the current in the catenary and tracks. These fields are functions of both the load of the nearby circuits, within the electrification sector, and the distance from them. As a train leaves the electrification sector between autotransformers, the magnetic field becomes considerably smaller since most of the traction power is supplied by smaller currents in the closely

spaced catenary and autotransformer feeder wire. Moreover, the magnetic field at the railroad wayside attenuates rapidly with distance from the tracks.

As expected, the largest wayside ELF magnetic field readings occurred on an overpass above the tracks because the probes were closest to the catenaries, approximately 4 m (13 ft) away. The average and maximum time varying magnetic field levels were 118 mG and 467 mG, respectively on the overpass and consisted primarily of 50 Hz components. Average and maximum time varying magnetic fields at the underpass below the tracks were lower, 1.7 mG and 8.7 mG, respectively. The time varying magnetic fields at the wayside 7.5 m (25 ft) from centerline of the track, averaged 7.2 mG and peaked at 24 mG. As at the overpass and underpass locations, the field was principally 50 Hz.

The attenuation at the open space along the wayside can be seen by comparing the average power frequency range field measured at 22.5 m (74 ft) to that at 7.5 m ((24.6 ft). The figures for the three trains that passed by are:

	<u>1ST TRAIN</u>	<u>2ND TRAIN</u>	<u>3RD TRAIN</u>
7.5 m (24.6 ft)	8.57 mG	8.77 mG	5.78 mG
22.5 m (74 ft)	2.39 mG	1.51 mG	1.63 mG

The electric fields measured at the open space along the wayside are due to the catenary and the feeder conductor. The highest measured electric field was 385 V/m at 7.5 m (24.6 ft) from the tracks.

The static magnetic fields at the wayside measurement locations on the high speed line (25 kV, 50 Hz) were essentially all geomagnetic in origin.

9.1.4 Passenger Station Platforms

The magnetic field environment on the open passenger station platform is similar to wayside levels, except that the rider is closer to the train, its power catenaries and tracks, but not as close as on the overpass. The average 50 Hz magnetic fields measured at the platform were 5.9 mG, considering all samples at all heights, and for trains going in both directions. The maximum value was 43.8 mG. Thus, the values do fall in between the higher readings at the overpass and the lower readings at either the underpass or at-grade open space along the wayside. The magnetic fields do exhibit a large temporal variability because they are functions of the train load in that electrification sector.

9.1.5 Electric Power Supply Stations

Only modest strength ELF magnetic fields were observed outside the fence of power supply stations. The measured average 50 Hz

magnetic fields were 5.0 mG at a point 2 m (6.6 ft) outside the fence at a substation and 3.4 mG at 2 m (6.6 ft) outside the fence at the autotransformer location. The corresponding measured maximum 50 Hz magnetic fields were 9.0 mG at the substation and 12.6 mG at the autotransformer location. Of course, the magnetic field levels inside the substation control house were larger, namely 10.9 mG for the measured average and 34.3 mG for the measured maximum, but that is as expected due to the proximity to large currents. The only static field was that of the earth.

The largest electric fields measured at the substation and autotransformer yard are due to the entering and exiting transmission lines and conductors. The highest measured electric field was 817 V/m at 4 m (13 ft) from the fence on the high voltage side of the substation.

9.1.6 Traffic Control Facilities

The major source of ELF magnetic fields in the TGV-A control room and the relay room is the current in the power supply to the equipment, however higher fields are present in localized areas near equipment. The measured average 50 Hz magnetic fields were 0.91 mG at the TGV-A control room and 0.36 mG at the relay room. The corresponding measured maximum 50 Hz magnetic fields were 3.10 mG in the TGV-A control room and 2.81 mG in the relay room. The maximum 50 Hz magnetic field level occurred at the sensor closest to the video display screen (see Table 8-5). There is also magnetic field harmonic content of comparable magnitude at the point close to the VDT. Static magnetic field levels were depressed below normal geomagnetic levels in the relay room at the Vendome Station, apparently due to structural steel in the building.

9.2 ENVIRONMENTAL MAGNETIC FIELD LEVELS

The predominant source of static magnetic field in the environment is the earth's geomagnetic field. The unperturbed geomagnetic field intensity varies over the surface of the earth from roughly 240 mG to 670 mG. The geomagnetic field level in the vicinity of Paris is approximately 470 mG. The presence of iron and steel components in buildings, vehicles, and structures perturbs the geomagnetic field in the vicinity of those objects causing variability in magnetic field intensities routinely encountered by people. Static magnetic field levels ranging from 200 mG to 1000 mG are frequently found.

Permanent magnets also represent localized sources of high intensity static magnetic fields. A child's toy magnet may have a flux density of several hundred to a few thousand gauss at its pole. Ferrite permanent magnets imbedded in seals and weatherstrips around refrigerator doors and home or office doors

and windows are frequently used, providing static fields of a few gauss at the portal.

The predominant ELF magnetic field in the environment is the 50 or 60 Hz magnetic field produced by virtually all equipment or facilities which generate, distribute, or utilize electric power. Due to the electrification of our modern society, power frequency (60 Hz in North America, 50 Hz in Europe) magnetic fields are ubiquitous. Numerous authors have reported environmental levels of power frequency magnetic fields for specific situations. Nair, et al.,⁴ provides a summary of that information as well as useful insight into the parameters which affect power frequency magnetic fields. Figure 9-1, extracted from Reference 4, shows the range of power frequency magnetic field levels which may be found at various distances from three important man-made sources of magnetic field.

Power frequency magnetic fields in American homes arise primarily from three sources: outdoor transmission and distribution power lines; house wiring; and household appliances. Field levels for transmission lines (69 kV or above), distribution lines (less than 69 kV), and appliances are summarized in Figure 9-1. Field levels from house wiring differ greatly from home to home. The total power frequency magnetic fields in homes is typically about 0.7 mG^{4,12} at the center of each room but can vary substantially from room to room or home to home. Magnetic field levels in excess of 10 mG at the center of a room are atypical but not terribly uncommon.

Power frequency magnetic field levels in the workplace are highly variable^{12,13}. In offices and most commercial establishments, the power frequency magnetic field environment is similar to or somewhat higher than that in homes. But in certain industrial settings, considerably higher ELF magnetic field levels above thousands of milligauss are encountered¹³. Unfortunately, field characterization in the workplace is limited to a small number of measurements which lack validity as indicators of "typical" or "overall" estimators of workplace magnetic field levels.

These common environmental sources of ELF magnetic field are predominantly power frequency field sources. Magnetic fields near power lines and substations may have low order harmonic components, but these are generally only a small percentage of the fundamental power frequency component¹². The harmonic content of residential and most workplace magnetic fields is also generally quite low, but on occasion can become a significant part of the total field. High harmonic content appears most frequently in magnetic fields near appliances containing non-linear electrical load control devices. Figure 9-2 shows a field by frequency and time plot for the magnetic field produced by a triac-controlled vacuum cleaner. Although the harmonic content is relatively large, only the lower order harmonics have significant amplitude. Essentially, no energy is present at frequencies below the power frequency.

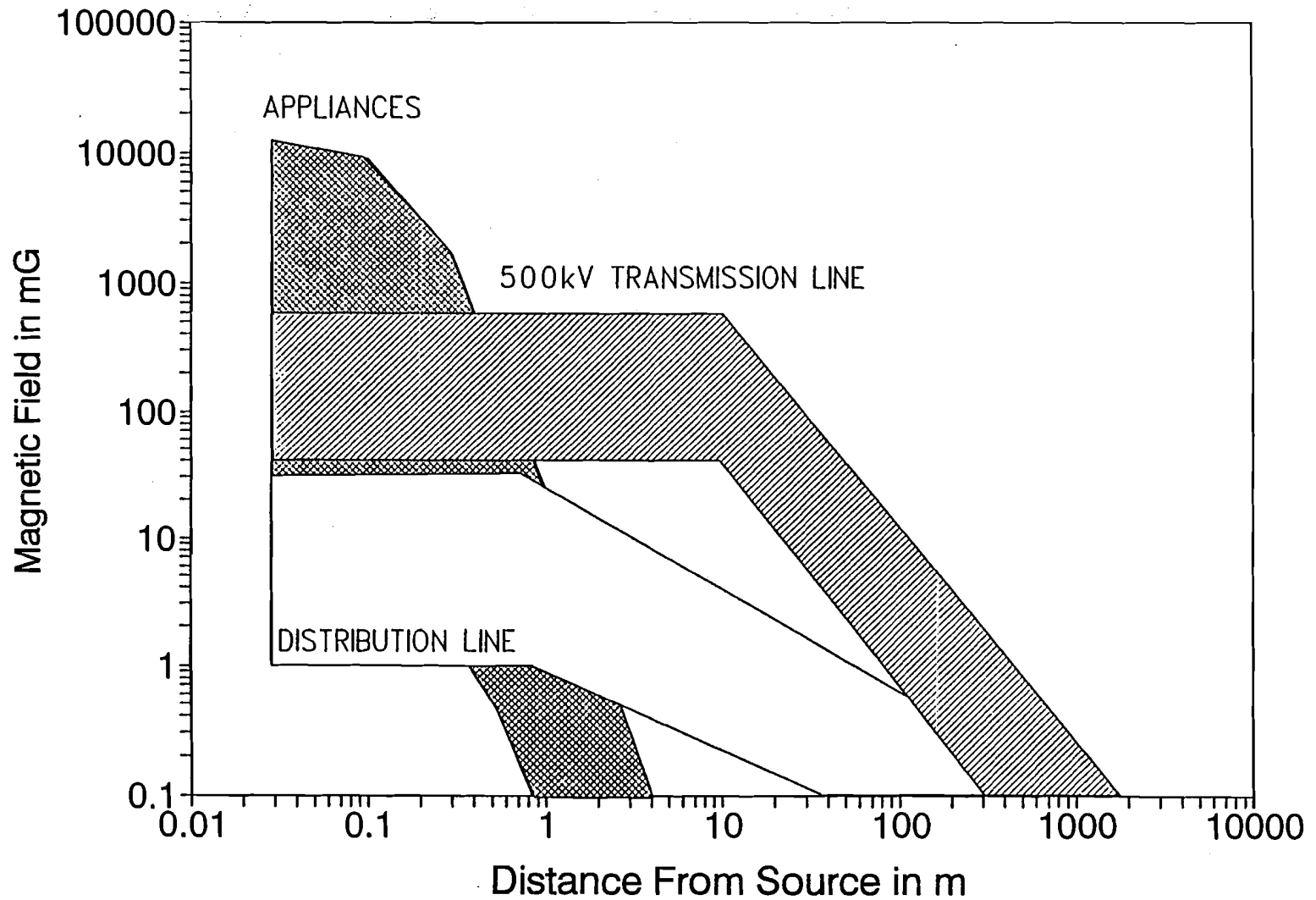

FIGURE 9-1. ILLUSTRATION OF HOW THE MAGNETIC FIELD INTENSITY AT GROUND LEVEL CHANGES WITH HORIZONTAL DISTANCE FROM THREE COMMON SOURCES OF POWER-FREQUENCY MAGNETIC FIELDS. THE BANDS REPRESENT VARIATION ACROSS INDIVIDUAL SOURCES IN EACH GROUP. ADAPTED FROM NAIR, ET AL⁴

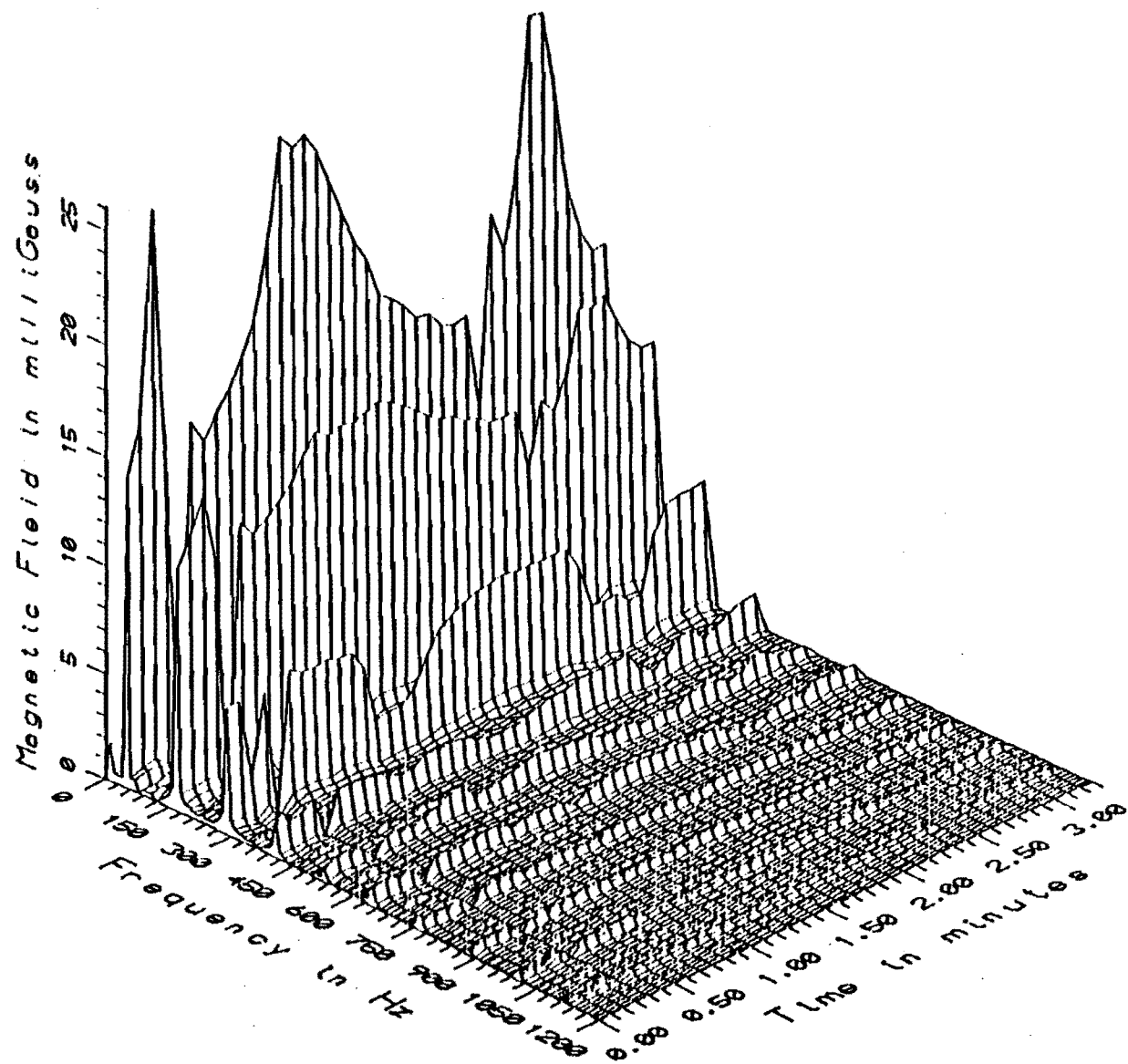

FIGURE 9-2. MAGNETIC FIELD 30 cm FROM A SHOP VAC

Televisions and computer video display units which make use of magnetic deflection are the most commonly encountered source of ELF magnetic fields at frequencies other than the power frequency. Vertical deflection frequencies for these devices are generally in the 55 to 75 Hz range; however, the magnetic fields are rich in harmonics. Horizontal deflection frequencies and their associated fields are well above the ELF range.

ELF electric fields in the environment arise most frequently from unshielded equipment or facilities used to generate, distribute, or utilize electric power. Like ELF magnetic fields, these electric fields have the frequency of the electric power system: 60 Hz in North America and 50 Hz in Europe. Since ELF electric fields are easily shielded by materials with even modest electrical conductivity, the predominant sources encountered by the general public are overhead electric power transmission and distribution lines, home or office electrical appliances and some electric lights. Nair, *et al.*,⁴ provide a discussion of environmental electric fields well summarized by Figure 9-3, which is extracted from their report.

9.3 COMPARISON OF TGV-A FIELDS TO OTHER ELECTRO-TECHNOLOGIES

Much of the concern about ELF magnetic field levels is driven by uncertainty as to whether such fields exert an adverse effect on human health. Existing scientific knowledge provides no sound insight as to what aspects of ELF magnetic exposure, if any, are of biological concern⁴. Consequently, public acceptance of magnetic field exposures is presently based more on equity and comparability to other exposures than it is to quantifiable characteristics of the field itself. Therefore, this section compares and contrasts the magnetic fields produced by TGV-A operation to other sources of magnetic fields.

9.3.1 Static Fields

Static (dc) magnetic fields caused by dc current in the catenary and track circuit exist inside the coaches and the locomotives while operating in the dc portion of the railroad line. Consequently, they fluctuate in response to traction power needs of the train. They are considered static fields in this report because the periods of their fluctuations are long (>2 seconds) compared to the field sampling period. Otherwise, the static fields are dominated by the natural geomagnetic field of the earth and are therefore quite constant with time. The static field is perturbed by nearby ferromagnetic material, such as steel in locomotives, coaches, station platforms etc. As such, the level varies with location. At outdoor locations at reasonable distances from large amounts of structural steel, such as at the locations outside substations and autotransformer yards, the measured static

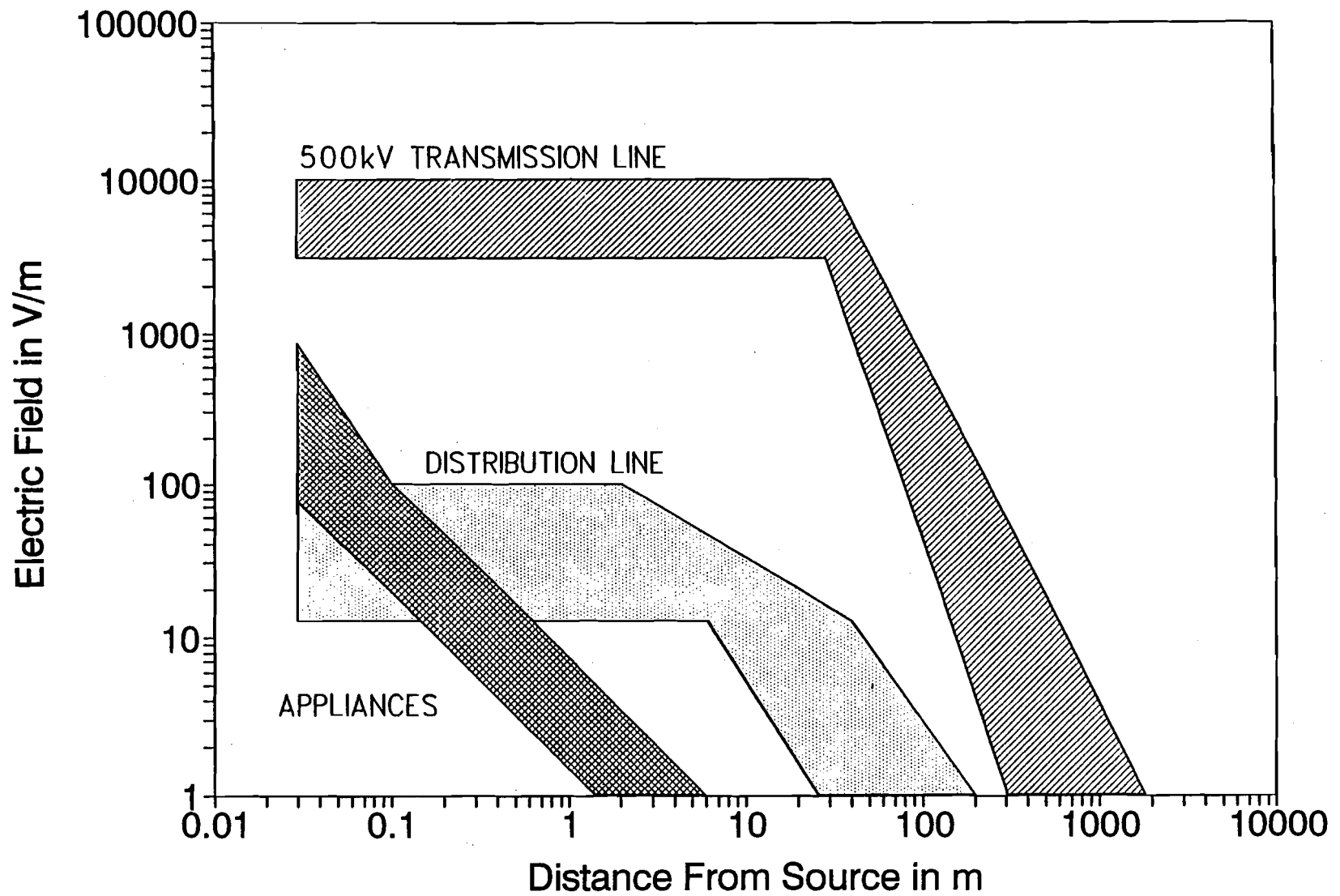

FIGURE 9-3. ILLUSTRATION OF HOW ELECTRIC FIELD INTENSITY NEAR GROUND LEVEL WILL CHANGE WITH HORIZONTAL DISTANCE FROM THREE COMMON SOURCES OF POWER-FREQUENCY ELECTRIC FIELDS. THE BANDS REPRESENT VARIATION ACROSS INDIVIDUAL SOURCES IN EACH GROUP. ADAPTED FROM NAIR, ET AL⁴

field measured 441 mG, which agrees well with the 470 mG value for the geomagnetic field level published for Paris.

9.3.2 Frequency Characteristics

The frequency characteristics of the magnetic fields onboard or near the TGV-A 50 Hz high speed line (e.g. Figures 3-3, 4-2, and 5-7) are similar to those near many electrical power systems and appliances. The main component of the field is the fundamental power frequency component, 50 Hz. However, there is also significant energy in the odd harmonics. In general, however, the magnetic fields onboard or near the TGV-A line have greater harmonic content than power lines but less than many appliances which employ electronic speed controls (e.g. the vacuum cleaner as reported in Figure 9-2).

9.3.3 Time Characteristics

The magnetic fields onboard the TGV-A trains or near the TGV-A tracks have pronounced temporal variability similar to the variability of magnetic fields near appliances with varying load or intermittent use. These fields have much greater variability than the fields found near most commercial electric power lines.

9.3.4 Amplitude Characteristics

Notwithstanding the need to compare the temporal and frequency characteristics of various ELF magnetic fields, this subsection will compare the measured ELF time varying field levels onboard and near TGV-A electrified railroad facilities to other reported environmental field levels from various power frequency sources. The lack of comparable environmental field data in several of the frequency bands, especially the low frequency (5-45 Hz) band, makes any other approach unworkable. The reader must be aware that the comparison of the total ELF fields of the TGV-A electrified railroad, especially in the coaches, to the predominantly power frequency, where there are significant low frequency field components, environmental field levels currently reported in the literature is an "apples and oranges" comparison, because frequency and temporal characteristics have been ignored in such a comparison.

9.3.4.1 Coaches - Figure 9-4 shows a comparison of the range of total ELF time varying magnetic fields measured in the coaches on the TGV-A train taken from Table 3-11 plotted over the graph of a typical power line and appliance field levels reported in Figure 9-1. Since there are multiple sources of magnetic field within the coach, most notably current in the overhead catenary, current in the 25 kV power cable along the tops of the coaches, and return

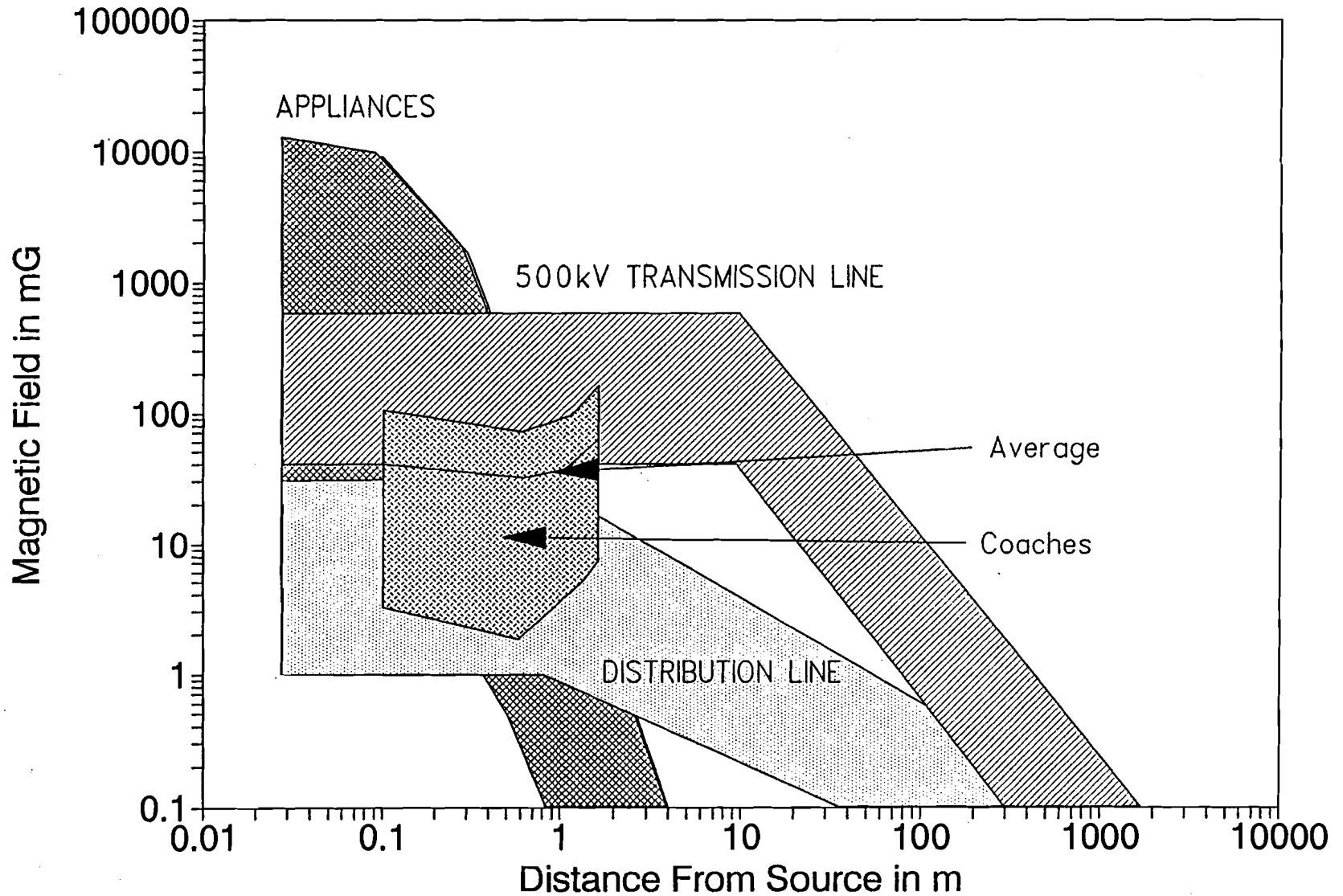

FIGURE 9-4. THE RANGE OF TOTAL TIME VARYING MAGNETIC FIELD LEVELS IN THE TGV-A PASSENGER COACHES AT VARIOUS HEIGHTS ABOVE THE FLOOR COMPARED TO TYPICAL LEVELS OF POWER-FREQUENCY MAGNETIC FIELDS PRODUCED BY COMMON SOURCES AT VARIOUS DISTANCES FROM THE SOURCE

current in the tracks, field levels are plotted as a function of height above the floor rather than distance from source. As the graph illustrates, the intensity of the ELF magnetic field inside the coaches is greatest near the floor and ceiling of the coaches and lowest at mid heights. That field pattern is consistent with the observation that fields within the coaches come from sources both above and below the vehicle. The range of magnetic field intensities spans nearly two orders of magnitude, including the range of magnetic fields found under distribution lines through large transmission lines. In comparison, fields of equal or greater intensity can be found close to appliances.

9.3.4.2 Locomotive Cabs - Figure 9-5 shows the range of total time varying magnetic fields recorded in the TGV-A locomotive cabs as a function of distance from the floor. The data are taken from Table 4-7 and are plotted over the same typical power frequency magnetic field levels given in Figure 9-1. From the figure, it is evident that the magnetic field levels in the locomotive cabs have many of the same spatial and temporal variability characteristics as the fields in the coaches discussed above and summarized in Figure 9-4. Although the average and maximum ELF magnetic field levels are higher in the locomotive cabs than in passenger coaches, current in the loop consisting over the overhead catenary and tracks beneath the train produces relatively uniform field levels throughout the cab but they are slightly elevated near the floor and ceiling. As in the coaches, the magnetic field levels in the locomotive cabs are within the range of field levels found beneath electric power lines or near electrical appliances.

9.3.4.3 Along the Wayside - The time varying magnetic field at the wayside appears to attenuate away from the catenary and tracks at a rate very near the theoretical rate of attenuation of two long parallel wires. This theoretical attenuation rate is proportional to the reciprocal of the square of the distance, as discussed in section 5-7. Figure 9-6 shows the plot of the ranges superimposed on the same Figure 9-1. There are three plots corresponding to the three measurement locations, namely the overpass, the underpass and the open space along the wayside. The distance from the source for the overpass and the underpass is measured vertically to the catenary. The distance for the open space is measured horizontally to the nearest catenary. The measured field data in Figure 9-6, like those in the corresponding figures with data at other measurement locations, are plotted only throughout the range of distances from the source where measurements were actually made. The figure should not be interpreted to imply that there are no fields nearer to nor more distant from the source than indicated in the graph, only that no measurements were made outside the indicated range of distances. Field levels outside the range of distances for which measured data exist can be estimated from the reported data by extrapolation using appropriate theoretical attenuation rates. Figure 9-6 shows that the range of magnetic

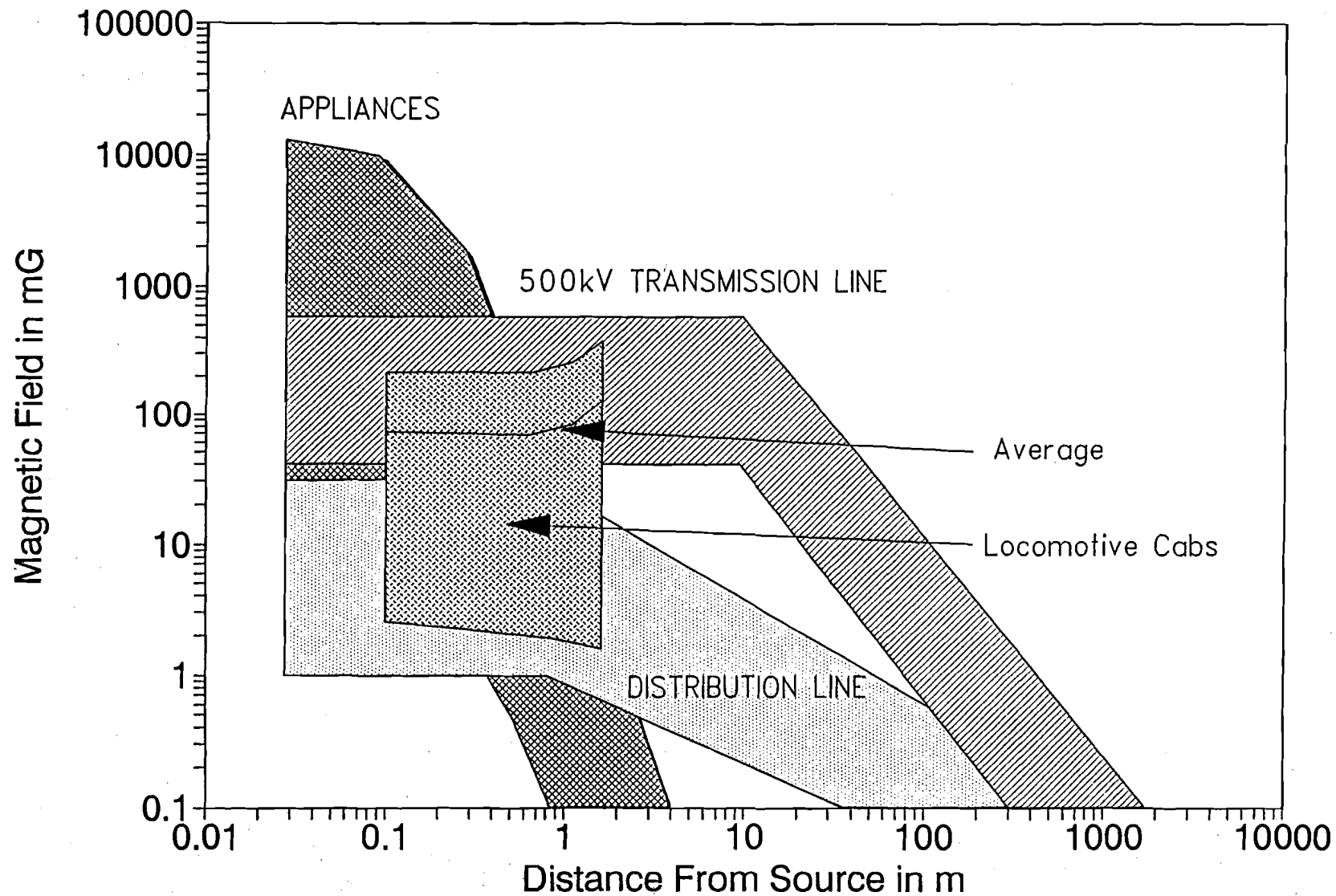

FIGURE 9-5. THE RANGE OF TOTAL TIME VARYING MAGNETIC FIELD LEVELS IN THE TGV-A LOCOMOTIVE CABS AT VARIOUS HEIGHTS ABOVE THE FLOOR COMPARED TO TYPICAL LEVELS OF POWER-FREQUENCY MAGNETIC FIELDS PRODUCED BY COMMON SOURCES AT VARIOUS DISTANCES FROM THE SOURCE

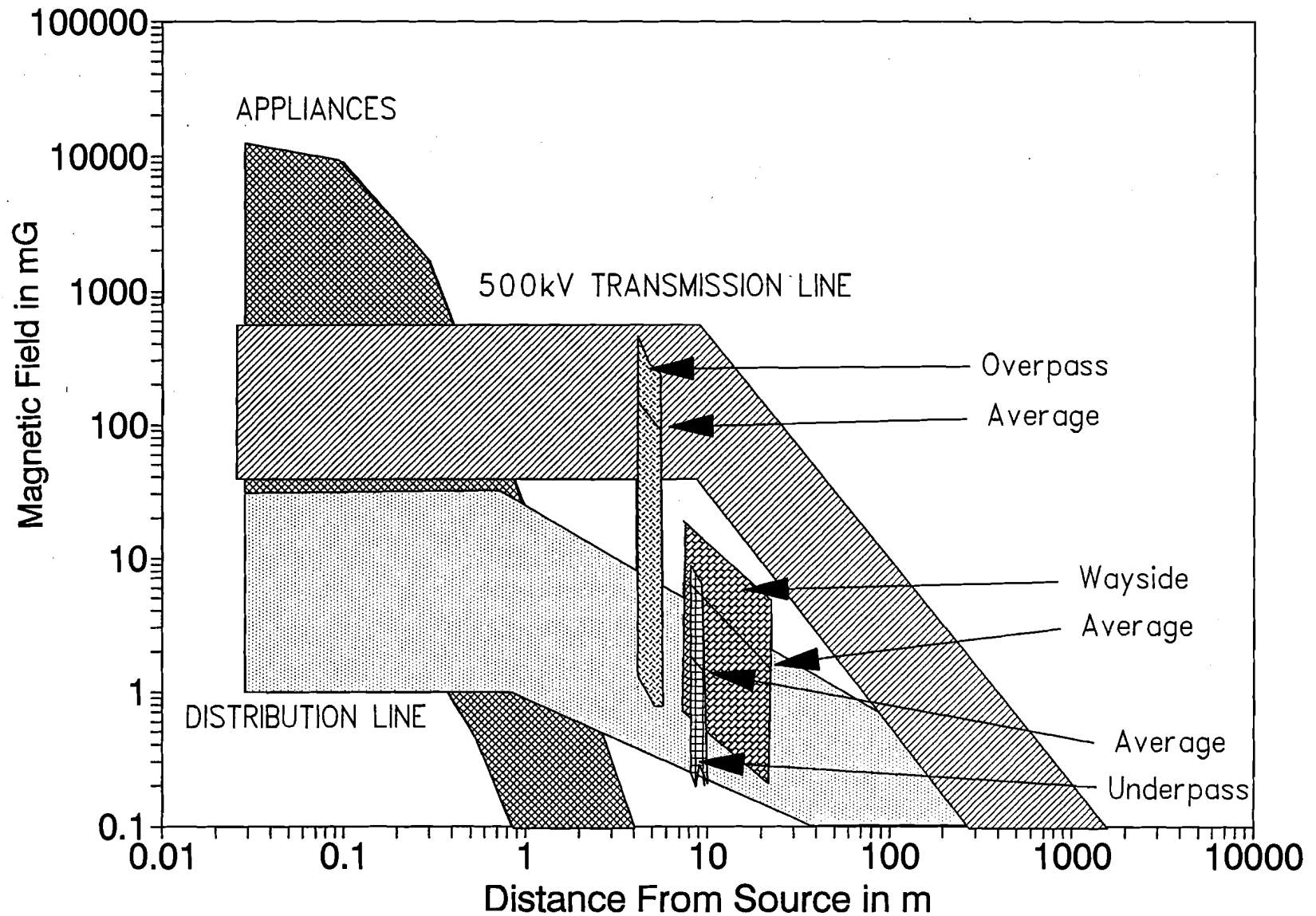

FIGURE 9-6. THE RANGE OF TOTAL TIME VARYING MAGNETIC FIELD ON AN OVERPASS, UNDERPASS AND OPEN SPACE ALONG THE WAYSIDE OF THE TGV-A ELECTRIFIED RAILROAD AT VARIOUS DISTANCES FROM THE NEAREST TRACK, COMPARED TO TYPICAL LEVELS OF POWER-FREQUENCY MAGNETIC FIELDS PRODUCED BY COMMON SOURCES

field levels at the wayside over distance from the track or catenary is in the general range of magnetic fields existing near power lines, including distribution lines and moderate-sized transmission lines.

The measured electric field attenuation curve shown as Figure 5-11 for an open wayside location is superimposed on the graph of commonly-encountered electric fields (Figure 9-3) to create Figure 9-7. Since these data were measured at an open area along the wayside without tall objects to shield or attenuate the electric field from the catenary and feeder wire, they represent the maximum field condition. Electric fields are smaller near man-made objects or tall vegetation or trees which effectively shield against electric fields. The range of the electric field is seen to span the range of electric fields produced by electric distribution lines and moderate-sized transmission lines.

9.3.4.4 Passenger Stations - The ranges of time varying magnetic fields measured on the Vendome passenger station at the edge of the platform adjacent to the tracks when trains are passing the station are shown in relation to other magnetic field sources in Figure 9-8. The range of magnetic field levels at the platform are in the general range of those near distribution lines. Magnetic field levels remain at the low end of the designated range when no trains are in the immediate vicinity of the station.

9.3.4.5 Substations and Autotransformers - Figure 9-9 shows the range of total time varying magnetic fields recorded 2 through 15 m (6.6 through 49 ft) outside the fence of the Gault St. Denis electric power supply substation. The data are taken from Table 7-4 and are plotted over the same typical power frequency magnetic field levels given in Figure 9-1. From the figure, it is evident that the magnetic field levels are within the range of field levels found beneath electric distribution lines and considerably lower than those near large electric power transmission lines.

Figure 9-10 shows the range of total time varying magnetic fields recorded 2 through 15 m (6.6 through 49 ft) outside the fence of the Chaillot autotransformer station. The data are taken from Table 7-6 and are plotted over the same typical power frequency magnetic field levels used previously (Figure 9-1). The range of these magnetic field levels is also within the range of field levels found beneath electric distribution lines.

The measured electric field attenuation curves plotted as a function of distance from the power facility fence, shown as Figures 7-6, 7-7 and 7-8, are superimposed on the graph of commonly encountered electric fields (Figure 9-3) to create Figure 9-11. This is a maximum boundary in that the minimum electric field can extend to near zero (see discussion in previous subsection "Along

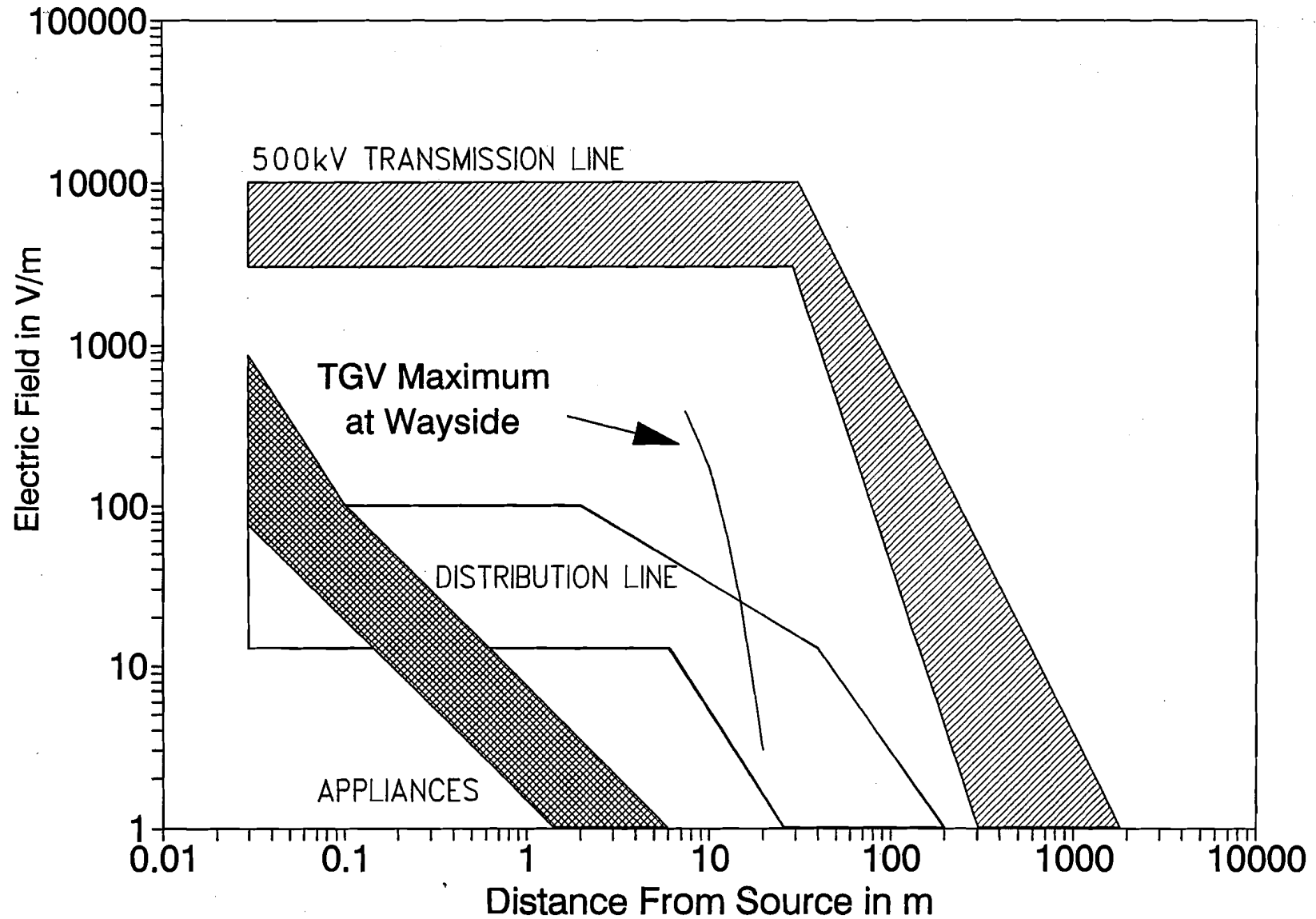

FIGURE 9-7. MAXIMUM TIME VARYING ELECTRIC FIELD AT THE WAYSIDE OF THE TGV-A ELECTRIFIED RAILROAD AS A FUNCTION OF DISTANCE FROM THE NEAREST TRACK COMPARED TO TYPICAL LEVELS OF POWER-FREQUENCY ELECTRIC FIELDS PRODUCED BY COMMON SOURCES

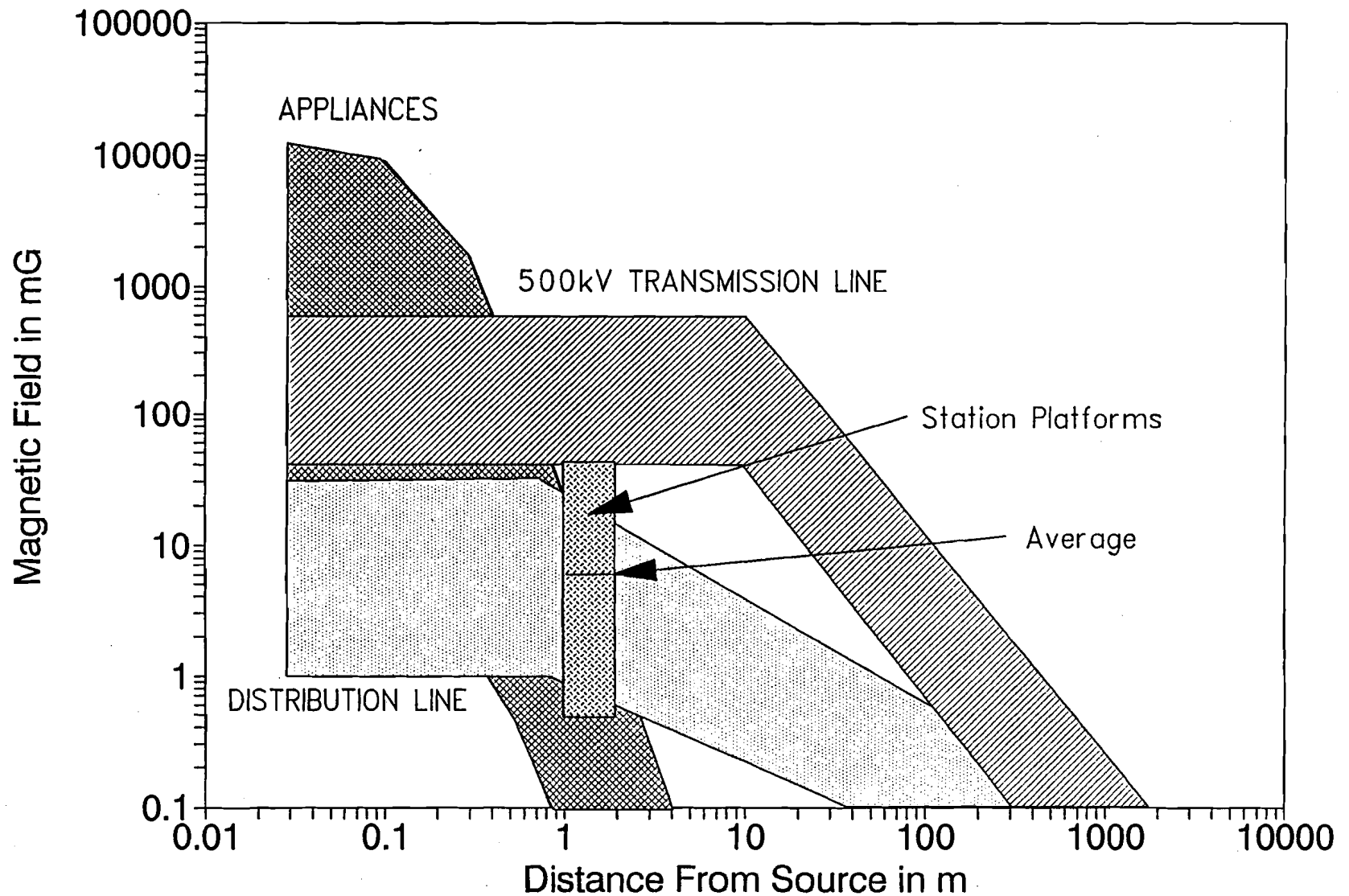

FIGURE 9-8.

THE RANGE OF TOTAL TIME VARYING MAGNETIC FIELD LEVELS ON THE VENDOME STATION PLATFORM APPROXIMATELY 1.5 m (5 ft) FROM CENTERLINE OF THE NEAREST TRACK COMPARED TO TYPICAL POWER-FREQUENCY MAGNETIC FIELD LEVELS FROM COMMON SOURCES

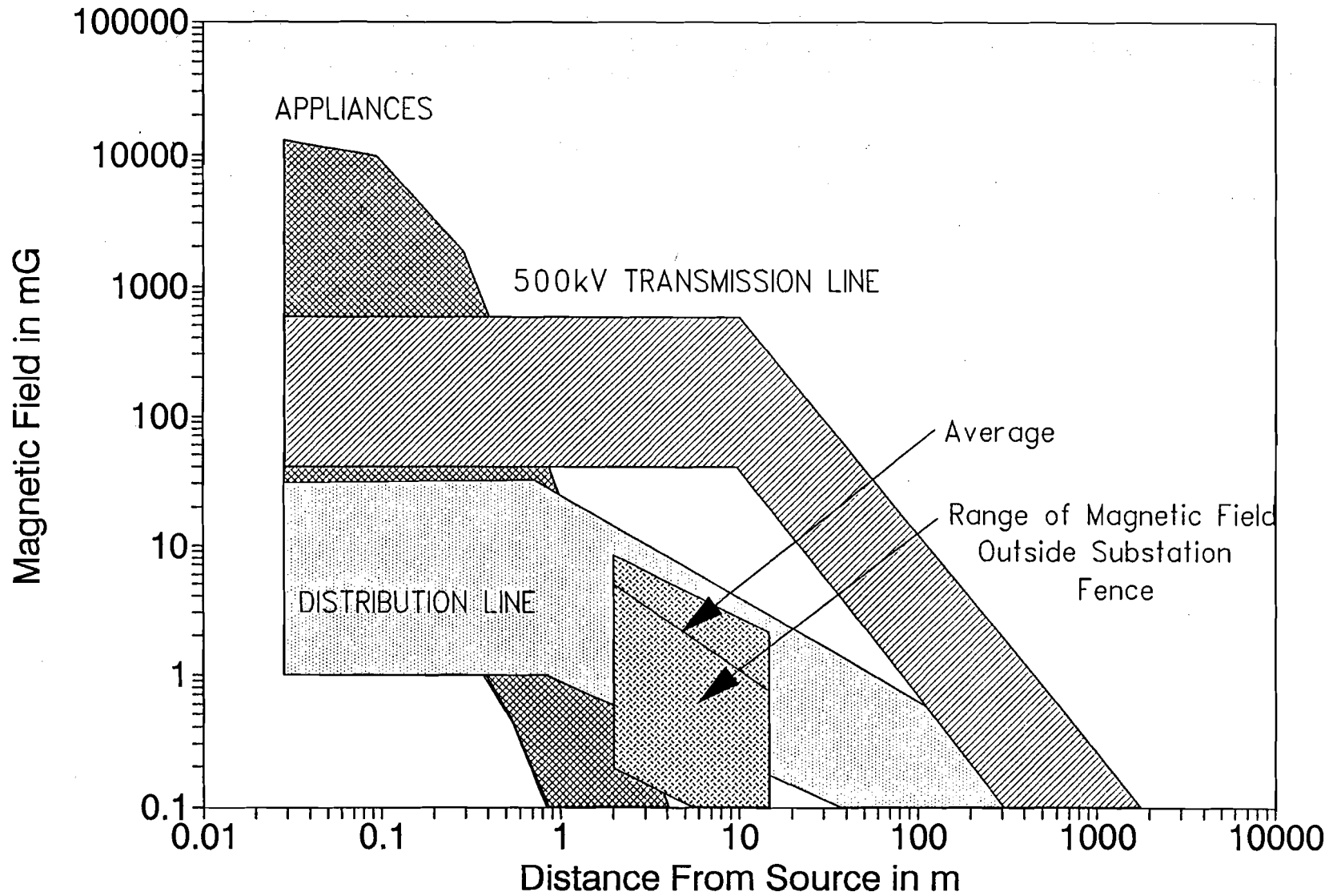

FIGURE 9-9. THE RANGE OF TOTAL TIME VARYING MAGNETIC FIELD LEVELS AT VARIOUS DISTANCES OUTSIDE THE FENCE OF THE GAULT ST. DENIS SUBSTATION COMPARED TO TYPICAL POWER-FREQUENCY MAGNETIC FIELD LEVELS FROM COMMON SOURCES

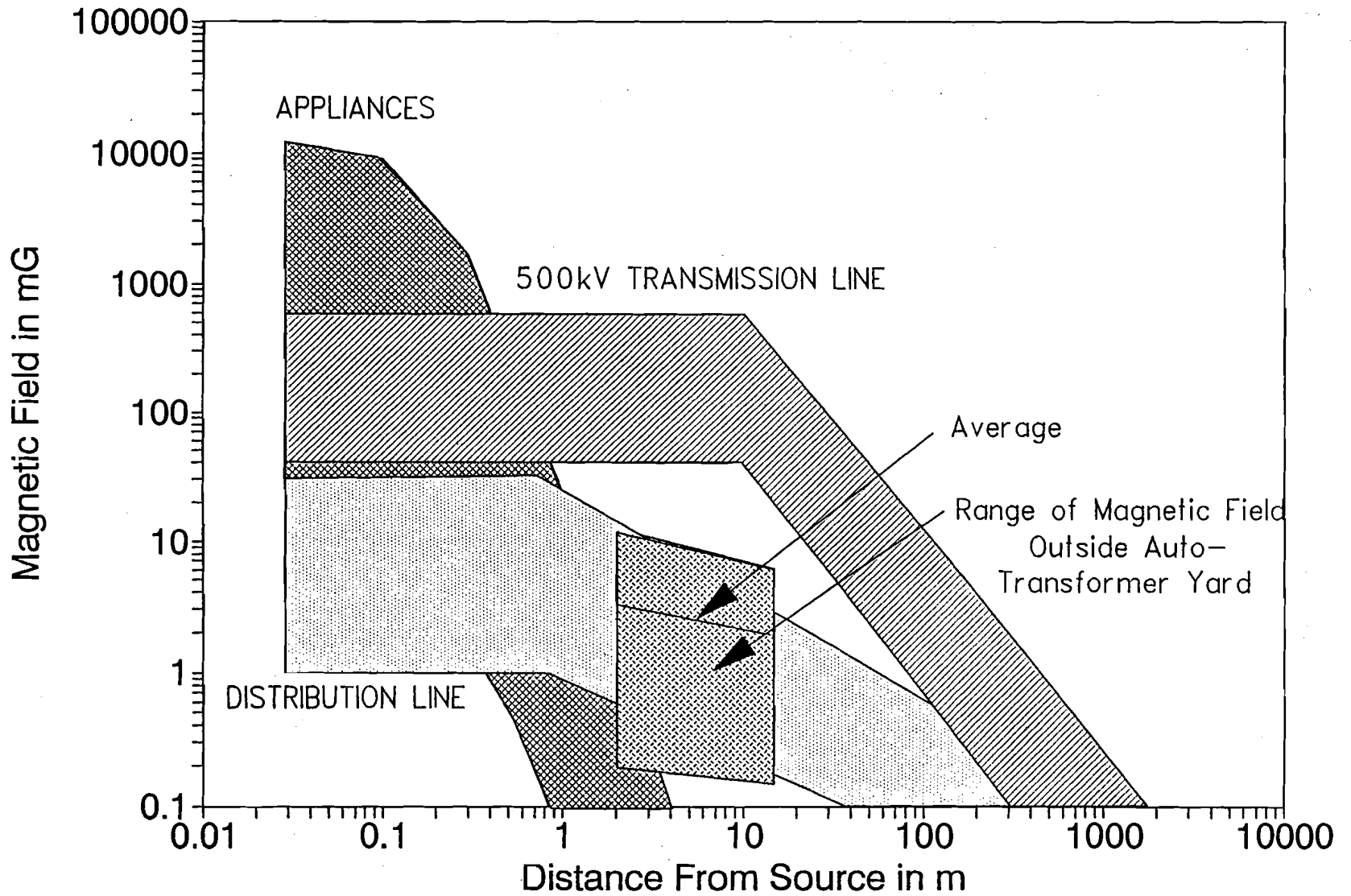

FIGURE 9-10. THE RANGE OF TOTAL TIME VARYING MAGNETIC FIELD LEVELS AT VARIOUS DISTANCES OUTSIDE THE FENCE OF THE CHAILLOT AUTOTRANSFORMER COMPARED TO TYPICAL POWER-FREQUENCY MAGNETIC FIELD LEVELS FROM COMMON SOURCES

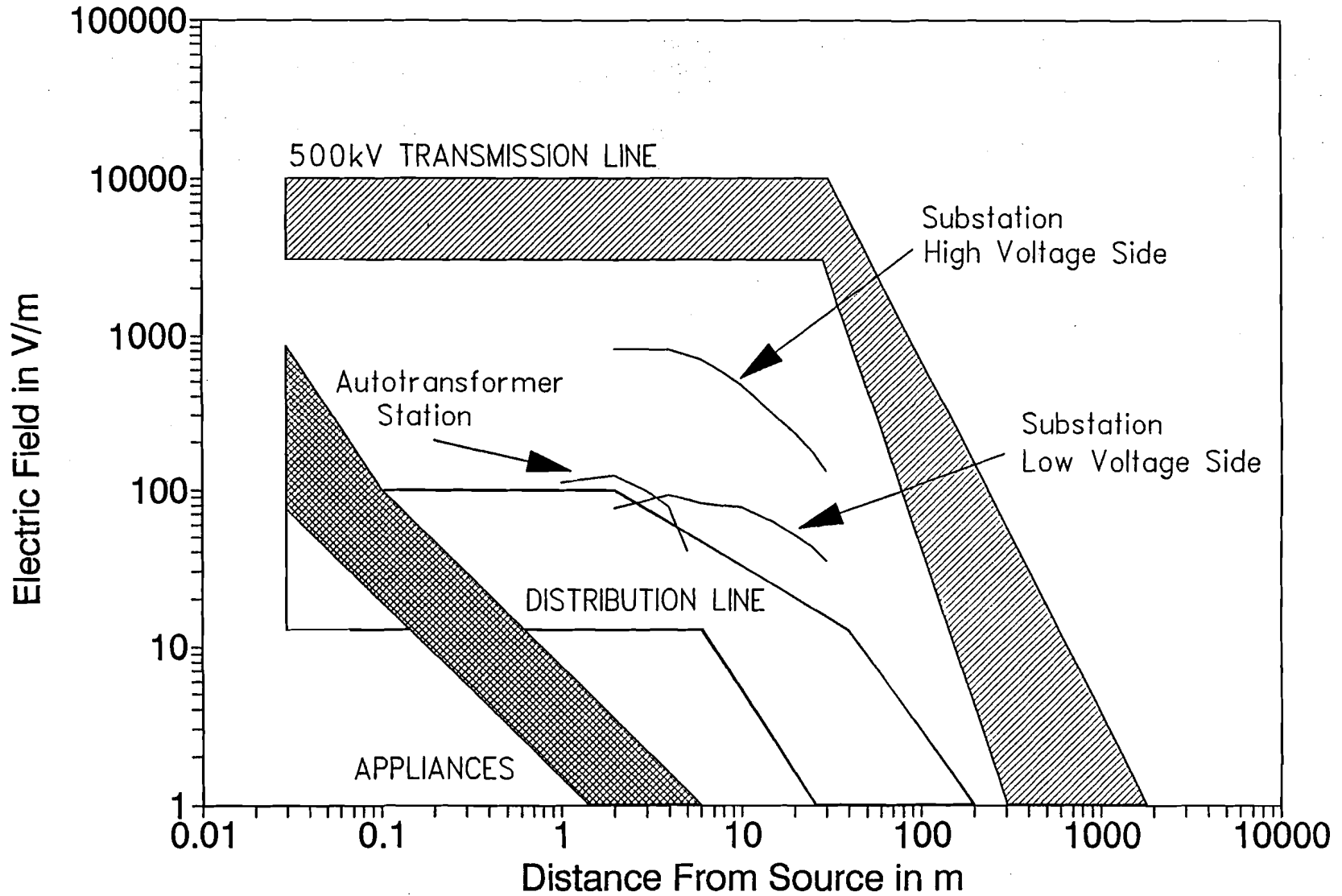

FIGURE 9-11. MEASURED TOTAL TIME VARYING ELECTRIC FIELD AT SUBSTATION LOW AND HIGH VOLTAGE SIDES AND AUTOTRANSFORMER STATION AS A FUNCTION OF DISTANCE FROM FENCE, COMPARED TO TYPICAL POWER-FREQUENCY ELECTRIC FIELD LEVELS FROM COMMON SOURCES

the Wayside"). The range of the electric field near the 50 kV autotransformer station and the 50 kV side of the substation is seen to span the range of electric fields produced by electric distribution lines. The higher electric field near the 200 kV side of the substation is consistent with electric field levels near other 200 kV facilities and considerably less than those near 400 kV or 500 kV facilities.

9.3.4.6 Traffic Control Centers - Figure 9-12 shows the plot of the range of time varying magnetic fields in front of the dispatcher's VDT in the TGV-A control room. The measured magnetic fields are superimposed on the same Figure 9-1 as before. The distance to the source is the distance to the VDT screen. The figure shows that the range of magnetic field levels in the TGV-A control room is within the general range of magnetic fields found near other common appliances and home or office equipment.

9.4 COMPARISON OF TGV-A FIELDS TO EXISTING STANDARDS

The United States has no national standards which establish limits on the intensity of ELF magnetic fields. There are two guidelines established by international organizations and one established by a domestic professional trade organization. Furthermore, there are two state level standards limiting ELF magnetic fields and several others limiting ELF electric fields. These state standards presently apply only to electric power lines and substations. This subsection of the report will compare the magnetic field levels onboard electrified railroads or near related facilities to the field levels permitted under the above-mentioned standards.

9.4.1 World Health Organization

The World Health Organization's *Environmental Health Criteria 35: Extremely Low Frequency (ELF) Fields*¹⁴ addresses both electric and magnetic fields but focuses more heavily on electric fields. Although it concludes that "adverse human health effects from exposure to ELF electric field levels normally encountered in the environment or the workplace have not been established" and sets no numerical limits for general or occupational exposure, it recommends limiting long-term exposures to 50/60 Hz electric fields to levels between 1 and 10 kV/m as "levels as low as can be reasonably achieved." The highest electric field levels found in the TGV-A coaches were 0.1 V/m. These field levels are four orders of magnitude below the lower end of this recommended limit. Electric field levels encountered in these tests are outside the substation fence are less than 1 kV/m.

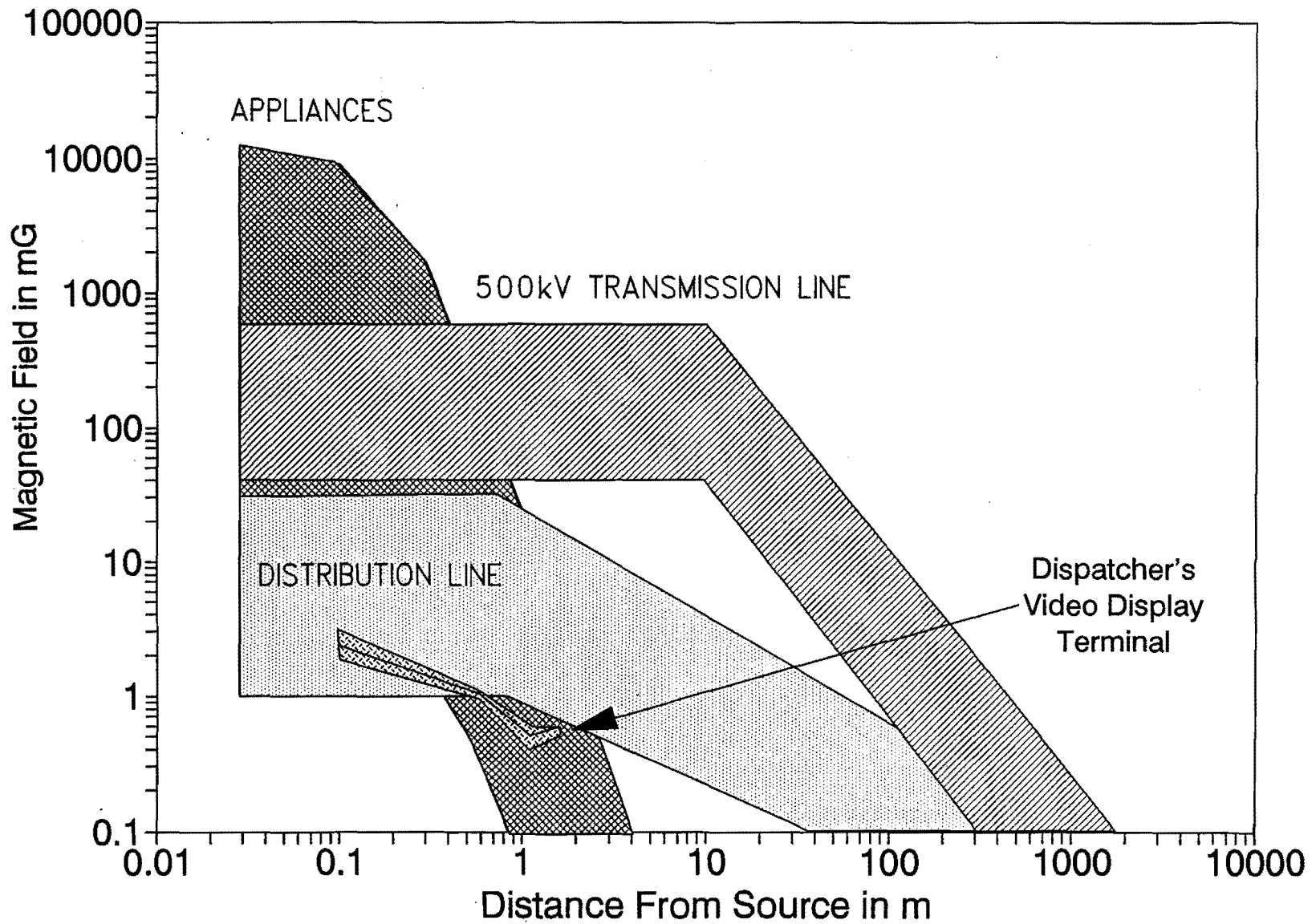

FIGURE 9-12. THE RANGE OF TOTAL TIME VARYING MAGNETIC FIELD LEVELS IN FRONT OF A DISPATCHER'S VIDEO DISPLAY TERMINAL COMPARED TO TYPICAL POWER-FREQUENCY MAGNETIC FIELD LEVELS FROM COMMON SOURCES

The World Health Organization's *Environmental Health Criteria 69*¹⁵ addresses ELF magnetic fields. The document concludes that available scientific knowledge does not permit establishment of a definitive limit for static or time varying magnetic fields. The document indicates that adverse human health effects are unlikely at static field levels less than 2 T (20,000 gauss) or with time varying magnetic fields which induce current densities of less than 10 mA/m² within tissue or extracellular fluids. Based on available scaling data for magnetically induced currents in the human body, the 10 mA/m² threshold is reached at power frequency field levels of approximately 10 gauss. The maximum ELF magnetic fields measured in the coaches or on the station platforms were less than 4% (400 mG) of the World Health Organization Criterion for time varying magnetic fields. Average time varying magnetic field levels at those locations are less than 1% (100 mG) of the criterion. Even greater margins of compliance are found for static magnetic fields or time varying magnetic fields at other locations.

9.4.2 International Radiation Protection Association

The International Non-Ionizing Radiation Committee (INIRC) of the International Radiation Protection Association (IRPA) has developed an interim standard¹⁶ limiting human exposure to power frequency (50/60 Hz) electric and magnetic fields. The established magnetic field limit for 24 hours per day to the general public is 1 gauss. Short-term exposures of a few hours per day are permitted up to 10 gauss. Occupational exposure levels are five times that permitted for the general public. The average time varying magnetic field level in the passenger coaches is approximately 3% of the 1 gauss, 24 hour limit. Average magnetic field levels in electric locomotive cabs are slightly higher, but of the same general magnitude as in the coaches.

The numerical field limits in the IRPA standard apply explicitly to power frequency electric and magnetic fields. However, the text of the standard clearly demonstrates that the standard is based on induced current concerns. Hence, acceptable field limits at frequencies other than 50 or 60 Hz would be related to the 50/60 Hz threshold by the ratio of the power frequency to the frequency of the magnetic field.

The power frequency electric field exposure limits recommended by IRPA for the general public are 5 kV/m continuous or 10 kV/m for a few hours per day. Recommended occupational exposure thresholds are two to three times higher. Maximum electric field exposure levels at stations were less than 1 kV/m or less than 20% of the continuous exposure threshold. Electric field levels at other locations are significantly lower.

9.4.3 American Conference of Governmental Industrial Hygienists

The American Conference of Governmental Industrial Hygienists (ACGIH) has established a "threshold limit value" (TLV) for 50 Hz magnetic fields at 12 gauss¹⁷. The document recommends that routine occupational exposures should not exceed the 12 gauss at 50 Hz value, but states that the value is to be used as a guideline, not as a strict determination of safe and unsafe levels. For example, values ten times less than the above TLVs are recommended for persons with implanted pacemakers. These TLV values are comparable to the guidelines recommended by the World Health Organization and the tenfold lower level suggested for pacemaker wearers is comparable to the IRPA guideline. As discussed above, the measured magnetic fields on or near the electrified railroads meet those criteria with comfortable margin.

The TLV for electric fields at frequencies of 100 Hz or less is 25 kV/m¹⁷. The highest electric field levels found around the existing TGV-A electrified railroad facilities were outside the high voltage side of the power substation, where the highest field was less than 4% of the TLV.

9.4.4 State Power Line Limits

The states of Florida¹⁸ and New York¹⁹ have adopted standards specifically limiting the intensity of the power frequency electric and magnetic fields at the boundaries of transmission lines' rights-of-way or substation property lines to values from 1.6 to 2.0 kV/m and 150 mG to 250 mG, depending on the type of transmission line. Both standards are established on a "status quo" basis rather than a health or safety basis. Although neither applies to transportation systems, they do provide some guidance as to the levels of magnetic fields which have been judged tolerable at the boundaries of linear facilities which are in that respect similar to electrified railroad corridors. The maximum electric field found 15 m (49 ft) from the tracks, an average TGV-A right-of-way boundary, was 0.025 kV/m and the maximum ELF magnetic field at that distance, determined by interpolation between nearer and more distant measurement points is 8.5 mG. Both electric and magnetic field levels are well below limits established by states for power line fields.

10. REFERENCES

1. Interim Report on Magnetic Field Testing of TR07 Maglev Vehicle and System Conducted August 1990, Electric Research and Management, Inc., May 1991, Revised August 1991.
2. Safety of High Speed Magnetic Levitation Transportation Systems, "Magnetic Field Testing of the TR07 Maglev Vehicle and System, Volume I - Analysis," U.S. Department of Transportation, Federal Railroad Administration, Washington, DC, DOT/FRA/ORD-92/09.I, DOT-VNTSC-FRA-92-6.1, Final Report April 1992.
3. Final Report on Magnetic and Electric Field Testing of the AMTRAK Northeast Corridor and New Jersey Transit North Jersey Coast Line Rail Systems - Volume I, Electric Research and Management, Inc., December 1992.
4. Biological Effects on Power Frequency Electric and Magnetic Fields, Indira Nair, M. Granger Morgan, H. Keith Florig, Office of Technology Assessment, OTA-BP-E-53, May 1989.
5. "Electrical Wiring Configurations and Childhood Cancer," N. Wertheimer and E. Leeper, Am J Epidemiol, 1979, 109:273-284.
6. "Case-Control Study of Childhood Cancer and Exposure to 60-Hertz Electric and Magnetic Fields," D.A. Savitz, H. Wachtel, F.A. Barnes, E.M. John, and J.G. Tvdrick, Am J Epidemiol, 1988, 128:10-20.
7. "Exposure to Residential Electric and Magnetic Fields and Risk of Childhood Leukemia," S.J. London, D.C. Thomas, J.D. Bowman, E. Sobel, and J.M. Peters, 1991, 134:923-937.
8. Magnetic Fields and Cancer in People Residing Near Swedish High Voltage Power Lines, Institutet för Miljömedicin, Karolinska Institutet, Maria Feychting, Anders Ahlbom, IMM-rapport 6/92, Stockholm 1992.
9. "Electric and Magnetic Fields: An EPA Perspective on Research Needs and Priorities for Improving Health Risk Assessment," EPA/600/9-91/016F, December 1992.
10. "French Railroads Efforts to Reduce Traction Electromagnetic Fields," Charles G. Gourdon, Presented at the First World Congress for Electricity and Magnetism in Biology and Medicine, Lake Buena Vista, FL, June 14-19, 1992.

12. Measurement of Power System Magnetic Fields by Waveform Capture, EPRI TR-100061, Project RP2942-1, Final Report, February 1992.
13. The EMDEX Project: Technology Transfer and Occupational Measurements, Volume 2: Project Description and Results, EPRI EN-7048 Volume 2, Project 2966-1, Interim Report, November 1990.
14. World Health Organization, Environmental Health Criteria 35: Extreme Low Frequency (ELF) Fields, Geneva, World Health Organization, 1984.
15. World Health Organization, Environmental Health Criteria 69: Magnetic Fields, Geneva, World Health Organization, 1987.
16. International Radiation Protection Association, Interim Guidelines on Limits of Exposure to 50/60 Hz Electric and Magnetic Fields, Health Physics 58; 113-22, 1990.
17. 1990-1991 Threshold Limit Values for Chemical Substances and Physical Agents and Biological Exposure Indices, American Conference of Governmental Industrial Hygienists, Third Printing.
18. Electric and Magnetic Fields, Chapter 17-274, Florida Administrative Code.
19. Statement of Interim Policy on Magnetic Fields of Major Electric Transmission Facilities, State of New York Public Service Commission, September 11, 1990.