



ASSOCIATION
OF AMERICAN
RAILROADS

A. J. Reinschmidt, Ph.D.
Assistant Vice President
Research and Engineering

January 31, 1994

RR
WRP

Members, Vehicle Track Systems Executive Committee:

Enclosed is a copy of AAR Report No. R-837, *"Bridge Tests by Using the Track Loading Vehicle."*

This report presents the results and conclusions from a series of bridge tests conducted using the TLV. The results indicate that the TLV can be used as a bridge testing machine in the study of stresses in bridge members under heavy axle loads. The test results also indicate that structural mode shapes, natural frequencies and damping can be measured by using the TLV. This provides more accurate prediction of dynamic responses of bridge structures than previously available.

Sincerely,

A. J. Reinschmidt
A. J. Reinschmidt

cc: R. A. Allen
S. B. Harvey
Members, Research Committee
Members, Engineering Management Committee
Members, Track Strength Characterization Committee.



ASSOCIATION
OF AMERICAN
RAILROADS

RESEARCH
AND TEST
DEPARTMENT

REPORT BRIEF

BRIDGE TESTS BY USING THE TRACK LOADING VEHICLE

R-837

December 1993

In June 1991, the Track Loading Vehicle (TLV) was used to conduct a series of tests on the Big Creek Through Truss bridge on Norfolk Southern Railroad in Tennessee. The tests were conducted to determine the utility of the TLV as a bridge testing machine. The bridge response to both static and dynamic loads applied by the TLV bogie was measured.

The results of these tests indicate that the TLV can be used as a bridge testing machine in the study of bridge member forces under heavy axle loads. It provides an alternative option to experimentally determine force distribution among bridge members. The vibration testing of a bridge using the TLV gives an additional aspect to bridge testing under controlled loads. Since deterioration of a structure would manifest itself as discrepancies between intermittently measured values of frequencies or damping, a periodic determination of them using the TLV provides a means to monitor a bridge member for damage or structural deterioration. The TLV is capable of conducting a wider range of static and dynamic tests on short span bridges which can be straddled by the TLV trucks and loaded solely by the centrally located load bogie.

The results indicate that the TLV provides a means to synthesize the effect of various loads on a bridge, and to determine the load distribution among bridge members. The measured axial forces were found to differ from those computed using analytical methods -- measured forces were often lower. This difference was attributable to truss connection fixities.

Results from the TLV dynamic tests simulating cyclic loading induced by passage of vehicles on the bridge

indicated a general increase in axial forces over static forces in all bridge members. The resulting impact factor, as a percentage increase of axial force in a member, was determined to be least in end posts and most in diagonals. The maximum impact percentages in bridge members were found to be lower than 35 percent. It was found that a large impact occurred only in a member with low static axial force.

Vibration testing of the bridge using the TLV proved to be useful in identifying natural frequencies and to measure damping. Resonance curves could be developed by plotting the excitation frequency versus peak amplitude of member axial force. The frequencies corresponding to dominant peaks in these curves were found to be the natural frequencies of bridge members. The frequencies thus determined were 3, 7 and 13 Hz for the first three natural modes of member vibrations.

The member axial force magnification at natural frequencies was used to determine member modal dampings. The damping values were found to be inversely proportional to relative amplitude of member vibrations.

Copies of the AAR Report: "BRIDGE TESTS BY USING THE TRACK LOADING VEHICLE" are available from the Document Distribution Center, Chicago Technical Center, 3140 South Federal Street, Chicago, Illinois 60616. The AAR report number is R-837; the price is \$10.00 for member railroads and \$100.00 for non-members. Illinois residents please add 8.75 % sales tax. The cost includes surface mail postage if mailed within North America. There will be a surcharge for any overseas mail. Checks should be made payable to the Association of American Railroads. This report was issued in December 1993. A report list is available upon request.

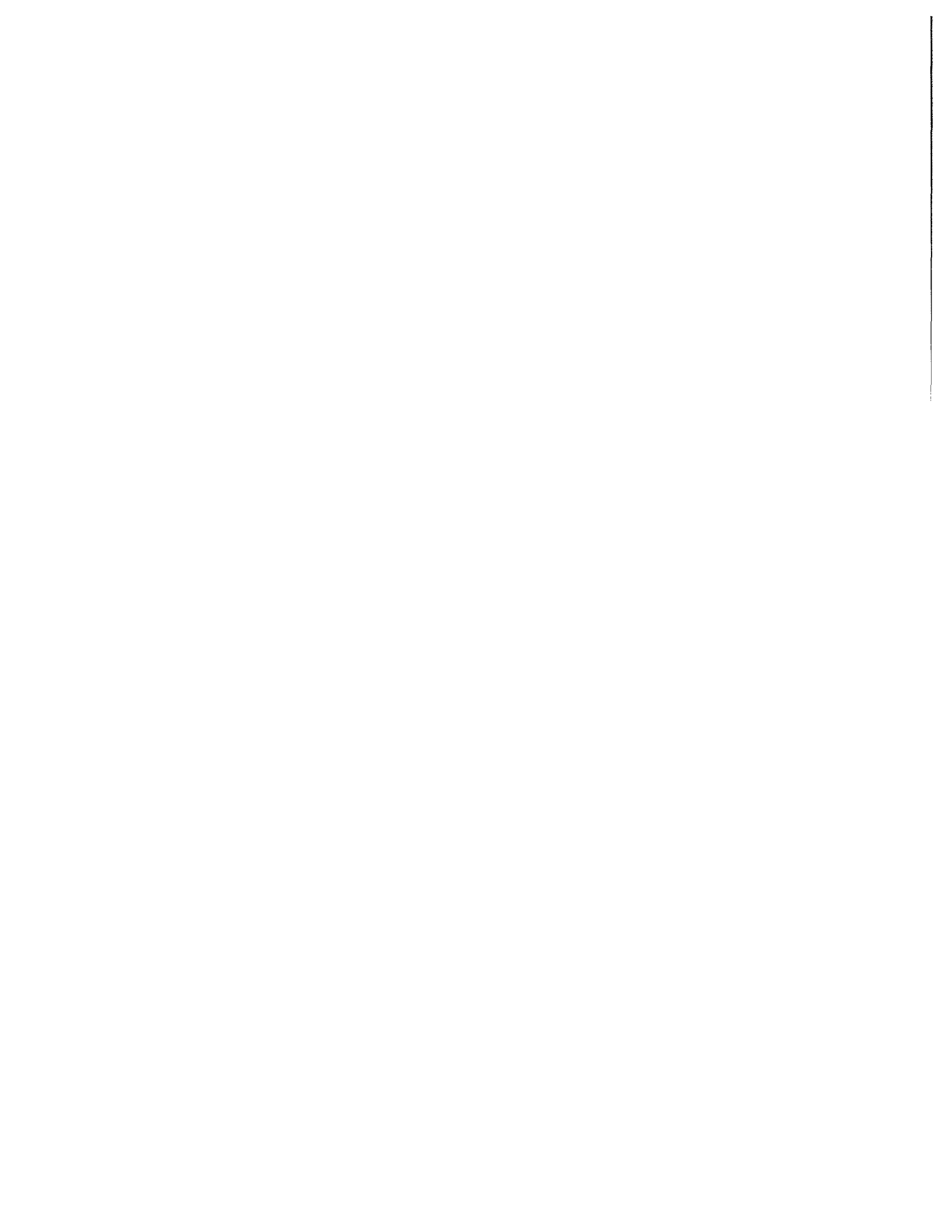

Association of American Railroads

Research and Test Department

**BRIDGE TESTS BY USING
THE TRACK LOADING VEHICLE**

Report No. R-837

by

Satya P. Singh

December 1993

Copyright © 1993
by Association of American Railroads

AAR Technical Center
Chicago, Illinois



DISCLAIMER

This report is disseminated by the AAR for informational purposes only and is given to, and accepted by, the recipient at his/her sole risk. The AAR makes no representation or warranties, either express or implied, with respect to the report or its contents. The AAR assumes no liability to anyone for special collateral, exemplary, indirect, incidental, consequential or any other kind of damage resulting from the use or application of this report or its contents. Any attempt to apply the information contained in this report is done at the recipient's risk.



1. REPORT NO. R-837	2. REPORT DATE December, 1993	3. PERIOD COVERED June, 1991 -
4. TITLE AND SUBTITLE Bridge Tests by Using the Track Loading Vehicle		
5. AUTHOR (S) Satya P. Singh		
6. PERFORMING ORGANIZATION NAME AND ADDRESS Association of American Railroads Technical Center 3140 South Federal Street Chicago, Illinois 60616	7. TYPE OF REPORT Research	
	8. CONTRACT OR GRANT NO. DTFR53-86-C-00011	
9. SPONSORING AGENCY NAME AND ADDRESS Federal Railroad Administration Office of Research & Development 400 7th Street, SW Washington, DC 20090	10. NO. OF PAGES 80	
	11. NO. OF REFERENCES 10	
12. SUPPLEMENTARY NOTES		
<p data-bbox="82 798 1588 840">13. ABSTRACT</p> <p data-bbox="82 840 1588 1039">The Track Loading Vehicle (TLV) was used to conduct a series of bridge tests. The Big Creek Through Truss Bridge on the Norfolk Southern Railroad in Tennessee was used for the tests. The theoretical and experimental axial forces in bridge members were compared. The TLV generated influence lines, impact percentages and resonance curves of member axial forces were determined. The damping ratios in bridge members were also evaluated.</p> <p data-bbox="82 1060 1588 1396">The results indicate that the TLV can be used in the study of stresses, impact percentages, mode shapes, natural frequencies and damping in the bridge and its members. An experimental TLV influence line for a selected bridge member can be obtained, leading to an assessment of the actual force distribution among various members. The test findings suggest that a significant difference can exist between the theoretically calculated stresses and those measured during the test - measured stresses are often lower. The TLV impact tests showed that least impact (increase in stress) occurred in end posts and most in the diagonals. The maximum impact percentages in the bridge members were found to be lower than 35 percent.</p> <p data-bbox="82 1417 1588 1591">The bridge natural frequencies were found to be 3, 7 and 13 Hertz in the first three modes. It was also found that member vibrations were not affected by the added mass of the TLV consist on the bridge, and thus provided a useful tool in ascertaining the vibrational characteristics of a truss bridge structure using the TLV.</p>		
14. SUBJECT TERMS Bridge, Trusses, Static Tests, Dynamic Tests, Track Loading Vehicle, Influence Line, Impact Percentage, Damping Ratio, Strain, Axial Force, Power Spectral Density, Mode, Frequency	15. AVAILABILITY STATEMENT Document Distribution Center Association of American Railroads Technical Center 3140 South Federal Street Chicago, Illinois 60616	





ASSOCIATION
OF AMERICAN
RAILROADS

RESEARCH
AND TEST
DEPARTMENT

REQUEST for FEEDBACK

Report No: _____ Report Title: _____

YES

NO

Did you find the report useful for your particular needs?
If so, how

Did you find the research to be of high quality?

Were the results of the research communicated effectively by this report?

Do you think this report will be valuable to workers in the technical area
represented by the subject area of the research?

Are there one or more areas of the report which need strengthening?
Which areas?

If you do not already, would you be interested in receiving Report Briefs
and Research Highlights covering AAR research?

Please furnish in the space below any comments you may have concerning the report. We are particularly interested in further elaboration of the above questions.

COMMENTS

NAME: _____

TITLE: _____

COMPANY: _____

ADDRESS: _____

Thank you for your cooperation. Please forward your comments to:
A. J. Reinschmidt, Assistant Vice President, Chicago Technical Center
3140 South Federal Street, Chicago, Illinois, 60616



EXECUTIVE SUMMARY

In June 1991, the TLV was used to conduct a series of tests on the Big Creek Through Truss Bridge on Norfolk Southern Railroad in Tennessee. The test program was undertaken to determine the utility of the TLV as a bridge testing machine. The TLV's capabilities to apply controlled static and dynamic loads were used to determine force distribution among the bridge members and predict an accurate dynamic response of the bridge structure. This was the first time that a device like the TLV was ever used for a bridge test.

The tests were conducted under both stationary and moving TLV conditions. The bridge response was determined by measuring member strains using strain gages. The strains were converted to the corresponding member axial forces to investigate the bridge response to controlled loads. Under the stationary TLV condition, the bridge response to both static and dynamic loads applied at various panel and in-between panel points on the bridge was measured. In these tests, the dynamic characteristics of the bridge were investigated by exciting the structure at frequencies up to 15 Hertz. The in-motion tests, on the other hand, were conducted to determine the effect of test speed on the bridge member forces. These tests were first run at 10 and 20 mph under a constant bogie-wheelset load of 33 tons. The tests were then repeated under a constant bogie-wheelset load of 39 tons.

The stationary static test results were used to determine the experimental axial force influence lines for various bridge members

as the TLV load configuration travelled across the structure. It was found that the TLV influence lines could be used to synthesize axial forces in bridge members due to any moving load on the bridge. These influence lines thus could be used to determine the actual load distribution among various bridge members. The static test results also showed that experimental axial forces in members could significantly differ from the corresponding analytically determined forces due to truss connection fixities and also due to the specific location of a strain gage on a member.

Dynamic simulation of bridge stresses, arising from the passage of freight car axles, was done by conducting the TLV impact tests at various locations on the bridge. The applied bogie-wheelset load was sinusoidally varied in these tests. For each load application on the bridge, the axial forces in various bridge members were determined. The dynamic amplification analysis was then done in terms of variation of impact percentages or forces in various bridge members. The results showed that the least impact percentage occurred in end posts and the most in diagonals. The maximum impact percentages in the bridge members were found to be lower than 35 percent. It was found that a large impact percentage occurred only when the static axial force in a member was small to start with.

The axial forces measured during the TLV resonance tests were used to develop resonance curves for various bridge members. These curves were obtained by plotting excitation frequencies against the corresponding peak axial forces in the members. The dominant peaks

in these curves correspond to the natural vibration modes of the bridge members. It was determined that bridge resonance occurred at frequencies of 3, 7 and 13 Hertz, corresponding to the first three vertical vibration modes. Due to the added mass of the TLV consist on bridge, it was estimated that these frequencies would be somewhat lower than the actual natural frequencies of vibration of the bridge structure. It was determined that a member resonance curve remained unaffected by the added mass of the TLV consist on the bridge. This isolation of member vibrations from the effect of added mass was found to provide a useful tool in ascertaining the vibrational characteristics of a truss bridge structure using the TLV.

The modal damping in a bridge member was determined using the dominant peak magnification in the member axial force resonance curve. As expected for framed steel structures, the bridge member dampings as a percentage of the critical damping, in the first natural mode, were found to vary from about 0.07 for end post and bottom chord to 6.49 for the hanger. The percentage of a member modal damping was found to be inversely proportional to the relative amplitude of the ensuing vibration.

It was determined that there were limitations in the use of the TLV for the long-span Big Creek Bridge tests. Some of these limitations were: a) the TLV consist did not represent a real train loading on the bridge; b) the unloading of the TLV trucks, equal in magnitude to the bogie-wheelset applied load, remained a permanent part of the applied load to the bridge, and could not be isolated

from the bogie-wheelset loads; c) the determined impact percentages might be high because of lower static stresses due to the lighter weight of the TLV consist; and d) the trial nature and limited scope of these TLV tests.

Finally and in spite of the above mentioned limitations, the results indicate that the TLV can be used as a bridge testing machine in the study of bridge member relative forces under heavy axle loads. The test vehicle provides a strong alternative option to experimentally determine the actual load distribution among various bridge members. The vibration testing of a bridge by using the TLV gives an additional aspect to bridge testing under controlled loads. The TLV can provide a means to monitor a bridge member for damage or structural deterioration, since such deterioration could be detected as discrepancies between periodically measured values of frequencies or damping. Lastly, the TLV is capable of conducting a wider range of static and dynamic tests on short span bridges which can be straddled by the TLV trucks and loaded solely by the centrally located load bogie.

TABLE OF CONTENTS

	<u>Page</u>
1.0 INTRODUCTION	1
2.0 TRACK LOADING VEHICLE DESCRIPTION	7
3.0 OBJECTIVE AND METHODOLOGY	13
4.0 TEST PROGRAM	15
4.1 <u>TEST CONSIST</u>	15
4.2 <u>TEST BRIDGE</u>	15
4.3 <u>INSTRUMENTATION</u>	17
4.4 <u>THE TLV TESTS</u>	20
4.4.1 <u>Stationary Tests</u>	22
4.4.1.1 The TLV Influence Line Tests	22
4.4.1.2 The TLV Impact Tests	25
4.4.2 <u>Forced Vibration Tests</u>	27
4.4.2.1 Resonance Tests	27
4.4.2.2 Frequency Sweep Tests	28
4.4.3 <u>Moving Tests</u>	28
5.0 TEST DATA ANALYSIS	31
5.1 <u>STATIONARY TEST RESULTS</u>	31
5.1.1 <u>The TLV Influence Line Results</u>	31
5.1.2 <u>The TLV Impact Test Results</u>	50
5.2 <u>FORCED VIBRATION TEST RESULTS</u>	59
5.2.1 <u>Resonance Test Results</u>	60
5.2.2 <u>Sweep Test Results</u>	62
5.3 <u>MOVING TEST RESULTS</u>	65
6.0 SUMMARY AND CONCLUSIONS	73
7.0 REFERENCES	79
8.0 APPENDICES	81
8.1 APPENDIX A: Axial Forces in North Truss	A-1
8.2 APPENDIX B: The TLV Influence Lines	B-1
8.3 APPENDIX C: The TLV Impact Percentages	C-1
8.4 APPENDIX D: Resonance Curves of Members	D-1

LIST OF EXHIBITS

<u>Exhibit</u>		<u>Page</u>
1.	A Photo of the Track Loading Vehicle with the Load Bogie Underneath the Center of the Vehicle	9
2.	Track Loading Vehicle Load Bogie with Split Axle and Gage Widening Load Application Mechanisms	10
3.	TLV Computer and Instrumentation Command Center	12
4.	The TLV Test Consist on Bridge, and Consist Weights and Distances Between Axles [8]	16
5.	Railroad Map of the Region, and Photograph of the Test Bridge [8]	18
6.	Schematic Layout of the Test Bridge [8]	19
7.	Truss Instrumentation Plan Including Channel Locations and Numbers used in the TLV Tests [8]	21
8.	Schematic of the TLV Load Configuration used for the TLV Influence Lines	24
9.	Axial Force Theoretical Influence Lines of Truss Web Members	32
10.	Axial Force Theoretical Influence Lines of Truss Top and Bottom Chord Members	33
11.	Strain Histories in West Hanger L1U1 (Upper End) of North Truss due to the Stationary TLV Test Consist with Bogie-Wheelset Static Load of 0.0 Tons Applied on West Floor Beam L1L1	35
12.	Strain Histories in West Hanger L1U1 (Upper End) of North Truss due to the Stationary TLV Test Consist with Bogie-Wheelset Static Load of 33 Tons Applied on West Floor Beam L1L1	36
13.	Strain Histories in West Hanger L1U1 (Upper End) of North Truss due to the Stationary TLV Test Consist with Bogie-Wheelset Static Load of 39 Tons Applied on West Floor Beam L1L1	37
14.	Theoretical and Experimental Axial Forces in North Truss Members due to the Stationary TLV Test Consist with Bogie-Wheelset Static Load of 0.0 Tons Applied on West Bridge Panel L2L3	38
15.	Theoretical and Experimental Axial Forces in North Truss Members due to the Stationary TLV Test Consist with Bogie-Wheelset Static Load of 33 Tons Applied on West Bridge Panel L2L3	39
16.	Theoretical and Experimental Axial Forces in North Truss Members due to the Stationary TLV Test Consist with Bogie-Wheelset Static Load of 39 Tons Applied on West Bridge Panel L2L3	40
17.	Theoretical and Experimental Axial Forces in South Truss Members due to the Stationary TLV Test Consist with Bogie-Wheelset Static Load of 33 Tons Applied on East Bridge Panel L1L2	42

LIST OF EXHIBITS

<u>Exhibit</u>	<u>Page</u>
18. Theoretical and Experimental Axial Forces in North Truss Members due to the Stationary TLV Load Configuration with Bogie-Wheelset Static Load of 33 Tons Applied on West Floor Beam L2L2	43
19. Theoretical and Experimental Axial Forces in North Truss Members due to the Stationary TLV Load Configuration with Bogie-Wheelset Static Load of 39 Tons Applied on West Floor Beam L2L2	44
20. Influence Lines of Axial Force in West Diagonal L2U1 of North Truss by Using the TLV Load Configuration Concept	46
21. Influence Lines of Axial Force in West Hanger L1U1 of North Truss by Using the TLV Load Configuration Concept	47
22. Strain Histories in West Hanger L1U1 (Lower End) of North Truss due to the Stationary TLV Test Consist with Bogie-Wheelset Sinusoidal Load of 33+/-7 Tons at 4 Hz Applied on West Floor Beam L1L1	51
23. Variation of Impact Percentages and Maximum Axial Forces in West Hanger L1U1 (Upper End) of North Truss due to the TLV Consist at Various Locations on the Bridge	52
24. Variation of Impact Percentages and Maximum Axial Forces in West Diagonal L2U1 (Upper End) of North Truss due to the TLV Consist at Various Locations on the Bridge	53
25. Variation of Impact Percentages and Maximum Axial Forces in West Hanger L1U1 (Lower End) of North Truss due to the TLV Consist at Various Locations on the Bridge	56
26. Maximum Impact Percentages in Various West side Members of North Truss from the Results in the TLV Impact Tests	57
27. Resonance Curve of the Axial Force in West Hanger L1U1 of North Truss from the Results of the TLV Steady-State Sinusoidal Tests on the Bridge	61
28. Damping Ratios in Various Members of North Truss from the Results of the TLV Steady-State Sinusoidal Tests on the Bridge	63
29. Power Spectral Density of the TLV Bogie-Wheelset Actuator Load on the Left Wheel for the 0-5 Hz Sweep Test	64
30. Strain Histories in West Hanger L1U1 (Upper End) of North Truss due to the Moving TLV Test Consist at 10 mph with Bogie-Wheelset Constant Load of 33 Tons	66
31. Strain Histories in West Hanger L1U1 (Upper End) of North Truss due to the Moving TLV Test Consist at 10 mph with Bogie-Wheelset Constant Load of 39 Tons	67
32. Strain Histories in West Hanger L1U1 (Upper End) of North Truss due to the Moving TLV Test Consist at 20 mph with Bogie-Wheelset Constant Load of 33 Tons	68

LIST OF EXHIBITS

<u>Exhibit</u>		<u>Page</u>
33.	Strain Histories in West Hanger L1U1 (Upper End) of North Truss due to the Moving TLV Test Consist at 20 mph with Bogie-Wheelset Constant Load of 39 Tons	69
34.	Strain Histories in West Hanger L1U1 (Upper End) of North Truss due to the Moving TLV Test Consist at 2 mph with Bogie-Wheelset Sinusoidal Load of 33+/-7 Tons at 1 Hz .	70

1.0 INTRODUCTION

The dynamics of railroad bridges excited by the action of moving trains is of great interest. There are no known cases of railroad bridge failure due to the traffic induced vibrations. There, however, are numerous examples of fatigue failure of bridge members due to the cyclic loading induced by the passage of vehicles. Recent developments in structural analysis techniques have made it possible to calculate the dynamic response of a bridge coupled to a train loading. The correlations of such analytical results with full scale measurements have, however, been very limited. Also, the response to the moving traffic has been measured for different types of bridges, but the studies of the natural frequency and damping behavior of the railway bridges and their members have been lagging.

A bridge structure is subjected to a series of load pulses as each axle of a train passes over it. Excitation frequencies resulting from these pulses depend on the wheel base, the truck spacing and the car length; and increase with speed from zero to about 15 Hz at 60 mph. Discrete track irregularities and wheel tread surface anomalies are some other parameters which can induce cyclic excitations to a bridge structure. This type of cyclic loading can excite a bridge resonance when the driving frequency coincides with one of the bridge natural frequencies, producing larger displacements and forces than those produced under static loads.

In addition to the great interest in the dynamics of railroad

bridges as mentioned above, an ascertainment of the remaining fatigue life and the requirement of increased Cooper E-Ratings with modern traffic of the existing railroad bridges are also widely recognized. The continuing trend toward heavier loads and increased traffic could result in an accelerated reduction in the life expectancy of the existing bridges.

Bridges represent a sizable capital outlay, and require a regular inspection to preserve the route integrity and safety. The costs are continually increasing for bridge inspection and maintenance. Because funds are limited for new bridge construction and for repair, rehabilitation, and strengthening of existing bridges, a careful evaluation needs to be made of all available research and technology to ensure optimum use of the resources.

In a needed effort to bring about a systems view, several research projects, under the auspices of the Association of American Railroads (AAR)'s new Vehicle Track Systems Program, were initiated in 1985. These projects are intended to analyze vehicle and track interaction problems to reduce track and equipment costs, and to improve the safety of train operations. The quantification of the lateral strength characteristics of in-place railroad track and the determination of the load environment under various types of operating conditions are among the major elements of this research program.

The Track Loading Vehicle (TLV) was built by the AAR in 1989 to be used as a major research tool to measure the strength of in-place track, to further enhance the understanding of derailments,

and to help in the determination of the strength of railway track structures and bridges under heavy axle loads. The potential utilization of the results obtained from the TLV is to develop better track inspection techniques, to build vehicles which cause less damage to the track, and to identify track locations requiring immediate maintenance.

As evident, a complete survey of structural strength of bridges, under the modern train traffic, is insurmountable in regards to the vast number of different types of railroad bridges. Notwithstanding this task, a bridge research program was initiated in 1987 under the joint auspices of the AAR and the National Science Foundation (NSF) [1]¹. The program is intended for the study of stresses and impacts to enhance the understanding and estimation of dynamic response and fatigue life of the bridges and their members. The TLV participation in this program was jointly funded by the Federal Railroad Administration (FRA) and the AAR. The FRA support in the testing of the TLV falls under the auspices of the Track Train Interaction Derailment Analysis Project under Task Order 6 of Contract DTFR53-86-C-00011. The various elements of this Task Order are:

- Sub-task 6a) Testing and Validation of Current Rail Restraint Criteria.
- Sub-task 6b) Track Lateral Strength Tests.
- Sub-task 6c) Demonstration of the TLV as a Bridge Test Loading Machine.
- Sub-task 6d) Rail Uplift Tests for Rail Longitudinal Force Measurement.

¹ Numbers in brackets refer to References listed in Section 7.0

This report presents the results from tests conducted under Sub-task 6c of the Task Order 6.

A number of typical bridges were selected for study under the AAR and NSF Bridge Research Project. These bridges were instrumented to obtain static and dynamic load spectra under unit-trains and intermodal traffic. Some of the results from this on going project are given in References 2, 3 and 4.

The selectivity in only testing the typical bridges also imposes limitations on such a test program. No matter how detailed, the results apply directly only to the bridges tested, and it is necessary to find some pattern underlying the results. The results from typical bridge tests would, therefore, require inferences to judge the behavior of other and non-typical bridges. A theoretical guide is helpful in achieving a similar and parallel end, and it is in this direction that the concept of the TLV load configuration influence line is proposed to be used. In this regard, a preference therefore, could be in testing of more bridges under the TLV's controlled static and dynamic loads, and in finding methods to apply these controlled test results to determine the structural strength of bridges.

Since the TLV provided capabilities in applying controlled static and dynamic loads through the bogie-wheelset, and the fact that the bridge-test problem is amenable to an approach by the influence line theory, it was decided to ascertain the potential of the TLV to test a railway bridge structural response. It was important for this study that the TLV bridge experiments be

conducted to evaluate the bridge structure characteristics as well as those of the loads rolling over the bridge. It was also equally important that methods be found to realistically apply these results to those under real train loads. It was the assessment of applicability of the TLV as a bridge loading device which made the basis of this report.

(This page left blank)

2.0 TRACK LOADING VEHICLE DESCRIPTION

The TLV is designed to simulate controlled derailment scenarios and provide controlled load environments to quantify the dynamic response characteristics of track [5,6,7]. The vehicle applies computer controlled loads to the track and measures the track response while either stationary or moving.

The design of the TLV is based on an extensive list of functional requirements selected to enhance and further the understanding of the phenomena that take place at the wheel/rail interface. The vehicle was designed to perform extensive measurement and data collection tasks over a diverse range of applications. Typical applications include tests of vertical and lateral track strength, track panel shift, gage widening, flange climb derailments, wheel/rail force/creepage relationships, wheel/rail wear, and rail corrugations.

The TLV consists of a loading platform, adapted from an SD45X locomotive underframe, carried by two-axle locomotive trucks. A fifth wheelset is mounted in a load bogie underneath the center of the vehicle. A new superstructure, providing the required strength and stiffness, was constructed over the underframe. The superstructure is a welded structure which is mainly constructed with various structural frames and I-beams welded to channel sections extending the length of the vehicle. A special load frame was constructed at the center of the vehicle and is used for supporting the vertical actuators. For stiffness, the sides and the top of the vehicle are completely covered with 1/4 inch sheet plates.

Exhibit 1 shows a photo of the TLV.

The load bogie is attached to the car frame to apply loads using the vertical actuators suspended from the car body and to measure responses. It is equipped with two servovalve controlled hydraulic actuators and associated load application mechanisms, a stub axle wheelset, a loaded gage measurement system, and other support equipment. A close-up photo in Exhibit 2 shows the stub axles and bearing arrangements, and the load application linkage mechanisms utilized in the gage widening load bogie.

Planned test scenarios necessitate the use of an active hydraulic control system. The hydraulic system consists of a hydraulic power supply, two 55-kip vertical, two 39-kip lateral, and two 39-kip gage widening actuators, servovalves, hydraulic service manifolds, and electronic control components. A six channel customized electro-hydraulic control system, MTS 458.10 series, is used to control the servovalves, hydraulic pressure and interlocks, and to accommodate computerized control sequences. All actuator channels are equipped with both force and stroke feedback.

A hydraulic pump with maximum flow capacity of 70 GPM is used to supply oil at 3,000 psi to the actuators. Electrical power for the vehicle is obtained from an on-board 250 KW diesel generator. This power supply provides energy for the hydraulic pump and for auxiliary uses such as lighting, heating, power tools, etc.

The TLV is operated from the AAR-100 Research Car which is equipped with electro-hydraulic control and data acquisition systems. The digital data collection software is configured to

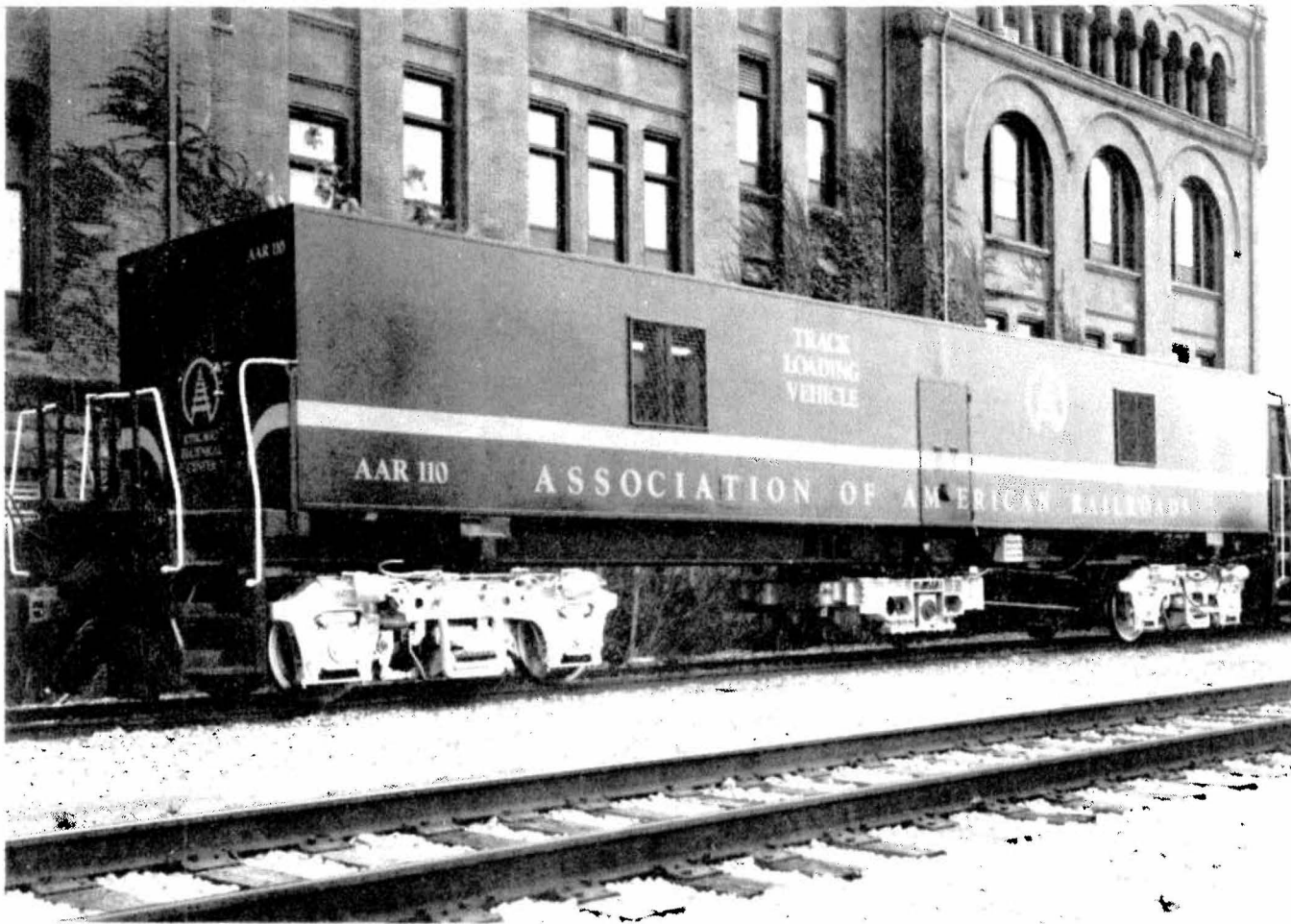

Exhibit 1. A Photo of the Track Loading Vehicle with the Load Bogie Underneath the Center of the Vehicle.

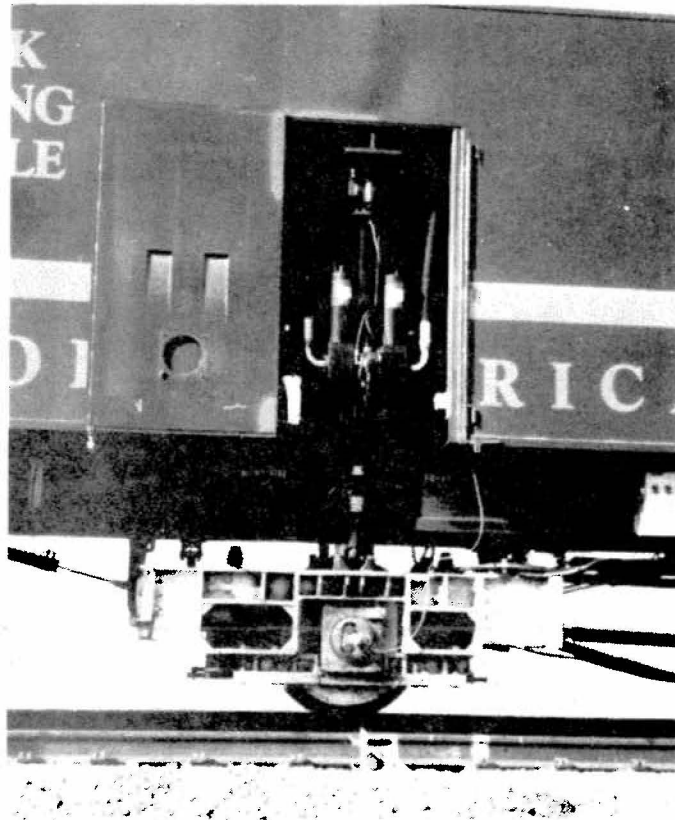
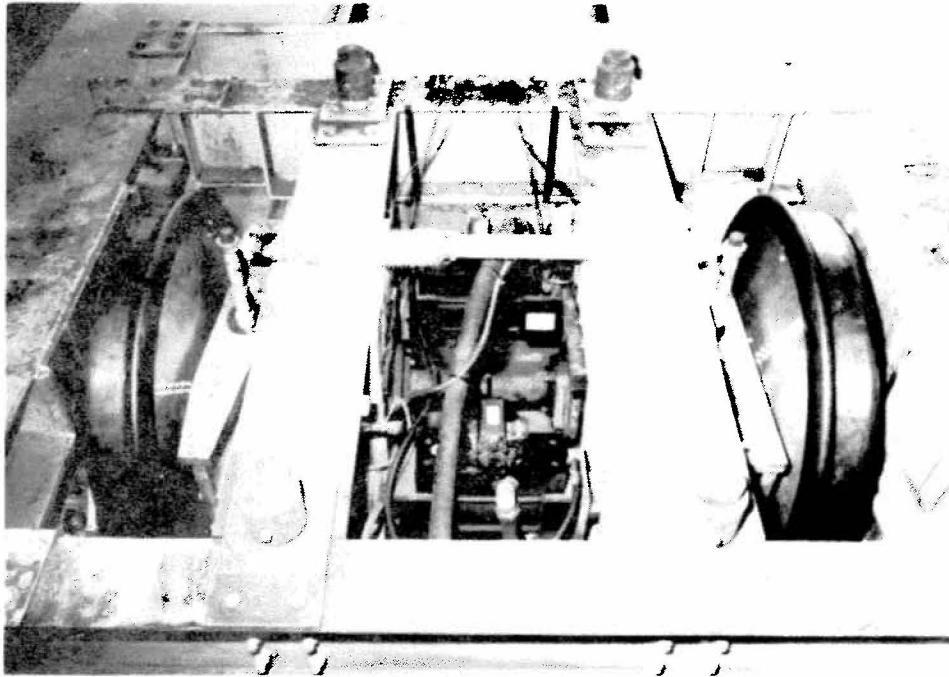

Exhibit 2. Track Loading Vehicle Load Bogie with Split Axle and Gage Widening Load Application Mechanisms.

perform data collection, transfer and storage tasks. Comprehensive control software is used to provide supervisory control over the hydraulic system. Exhibit 3 shows a photo of the TLV computer system which resides inside the AAR-100 Research Car.

Computer controlled vertical and gage spreading loads are applied to the track structure by hydraulic actuators through the load bogie and split-axle wheelset. The loaded and unloaded track gage as well as the gage widening loads are measured. These measurements are used to determine the gage widening resistance of track. During operation, the TLV control system compensates for small irregularities in the track vertical and lateral alignments. Active intervention by the computer is also required during the transition from tangent to curves. Various fail safe mechanisms have been built into the TLV system in case of hydraulic power or computer failure.



Exhibit 3. TLV Computer and Instrumentation Command Center.

3.0 OBJECTIVE AND METHODOLOGY

The TLV bridge tests were conducted on the Big Creek Through Truss Bridge of Norfolk Southern Railroad in Tennessee. These tests were an addition to the ongoing tests on this bridge under the AAR's bridge test program. The primary objective of these tests was to assess the use of the TLV as a bridge testing machine. This report, therefore, is a companion to the report "Static and Dynamic Testing of a Through-Truss Bridge" [8].

The tests using the TLV were devised to gather as complete a bridge response as possible. As such, these tests consisted of the evaluation of structural characteristics of the bridge, and also generation of characteristics of loads rolling over the bridge.

Test data were thus collected for frequency sweep and discrete frequency tests up to 15 Hz for the fundamental bridge structure characteristics. Characteristics of the bridge and its members, in terms of the resonant frequencies and damping within this frequency range, were thus determined.

The characteristics of loads rolling over the bridge were ascertained by collecting data for stationary static tests, stationary steady-state dynamic tests, moving tests and the moving bounce test. The stationary static tests were conducted to determine influence lines for assessing the effect of variation in the magnitude of loads and also composition of the trains. The stationary steady-state dynamic tests giving impact variation and the moving tests were conducted to determine the effect of speed on the magnitude of moving loads in terms of impact percentages. The

moving bounce test was conducted to simulate vehicle dynamics on the bridge.

These Big Creek Bridge tests using the TLV were the first such tests in an attempt to investigate usefulness of the TLV as a tool in bridge testing. It was expected that test results would provide enough information to synthesize the effect of any train composition on the bridge.

4.0 TEST PROGRAM

4.1 TEST CONSIST

The TLV test consist comprised of a 4-axle locomotive, AAR-100 Research Car and the TLV, as shown in Exhibit 4. The consist weights and axle spacings are also shown in this exhibit.

Computer controlled vertical wheel loads were applied to rails on the bridge structure by hydraulic actuators through bogie frame and the split-axle wheelset. The response of critical bridge members, in terms of strains, was measured by the two existing wayside data acquisition systems. The measurement of applied wheel loads was made by the onboard data collection system. The measurements were digitized at 256 samples per second.

4.2 TEST BRIDGE

The test bridge was a 156 foot, 3 inch long through-truss located on the Norfolk Southern line between Knoxville, TN, and Asheville, NC. The bridge was built in 1919. The open deck on the bridge was supported on floor beams at 26 feet and 1/2 inch centers, and stringers on 6 feet and 6 inch centers. The deck had 10" x 10" wood ties, 10 feet long, spaced on 18 inch centers. Each truss was composed of six panels. The trusses were spaced 16 feet 8 inch on centers. The bridge orientation was east-west. A 5-degree left hand curve on west approach to the bridge extended up to the first interior floor beam on west end of the bridge. Correspondingly, a speed restriction of 25 mph existed on this bridge. The bridge had a single track with 132RE jointed rails.

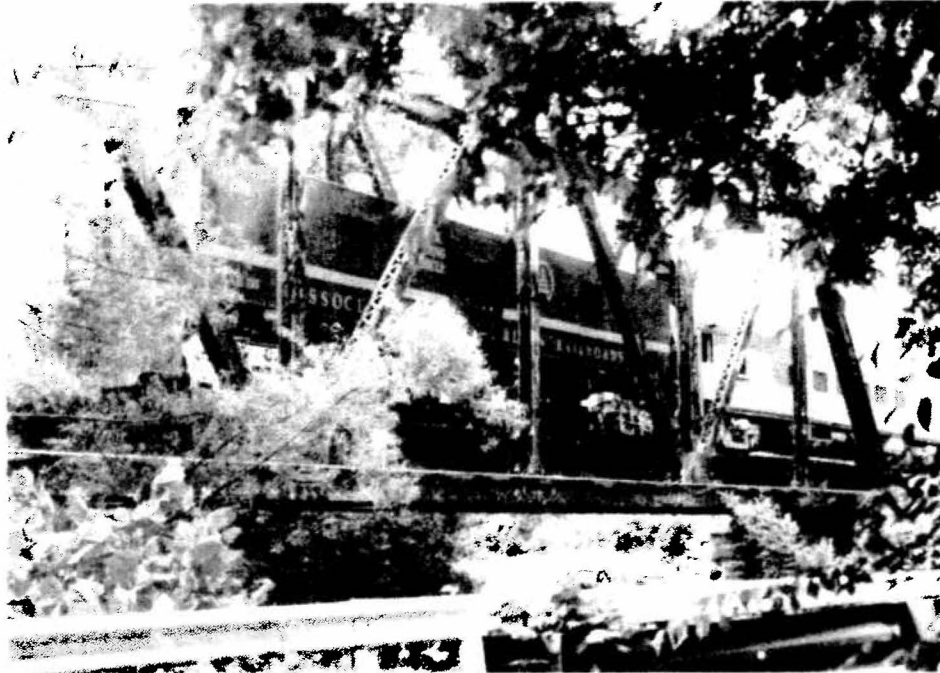

TEST CONSIST USING TLV

June 1991

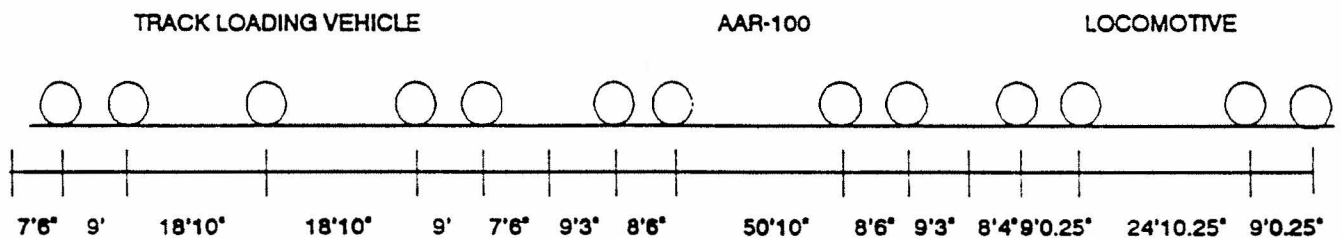

Wt. of the TLV = 270,000 lb

Wt. of the AAR-100 car = 136,000 lb

Wt. of the locomotive = 242,000 lb

Exhibit 4. The TLV Test Consist on Bridge, and Consist Weights and Distances Between Axles [8].

A railroad map of the area and a photograph of the bridge are shown in Exhibit 5. A schematic of the bridge is shown in Exhibit 6. Details of cross-sections and corresponding section properties of various bridge members are given in Ref. 8.

4.3 INSTRUMENTATION

As noted before, the bridge response in terms of strains of various critical members was measured by wayside data acquisition systems. This system consisted of two personal computers capable of collecting 32 channels of information on each system. A total of 64 channels of data could thus be collected at any one time.

In accordance with implementation plan of the AAR's Bridge Research Program, a number of critical truss members and floor system members had existing instrumentation to measure strains. The truss members, according to this plan, were instrumented to determine the mean axial stresses and extent of bending arising due to fixity in the connections. Similarly, the stringers and floor beams were instrumented to determine fixity of stringer connections to the floor beams, and the fixity of floor beam connections to trusses. Diagonals and end posts, bottom and top chords, and hangers of only the west half of both the north and south trusses were instrumented. This arrangement was dictated partly by the dry access underneath west side of the bridge, and the basic assumption that response of east half of the bridge would be similar due to symmetry.

A complete listing of the instrumentation is given as an

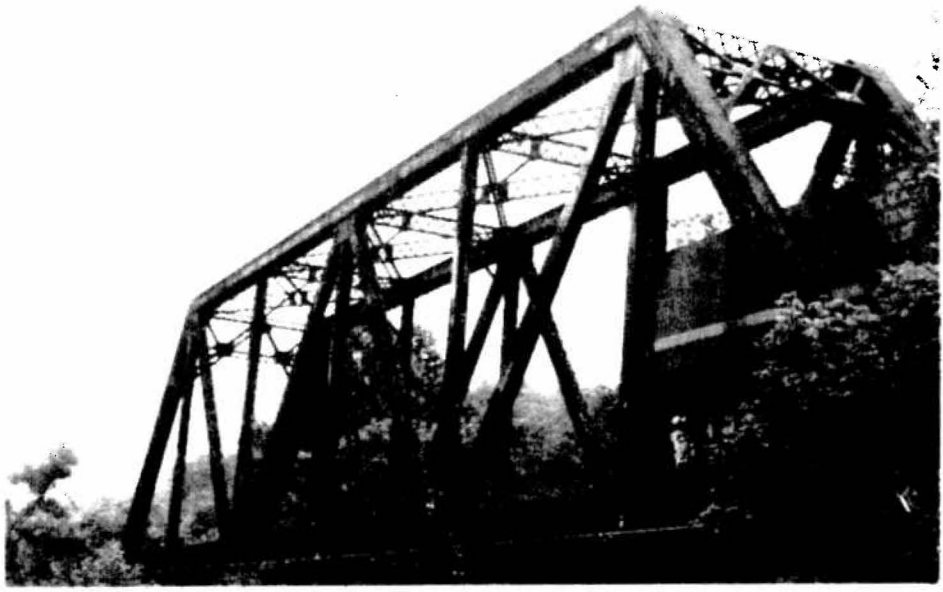
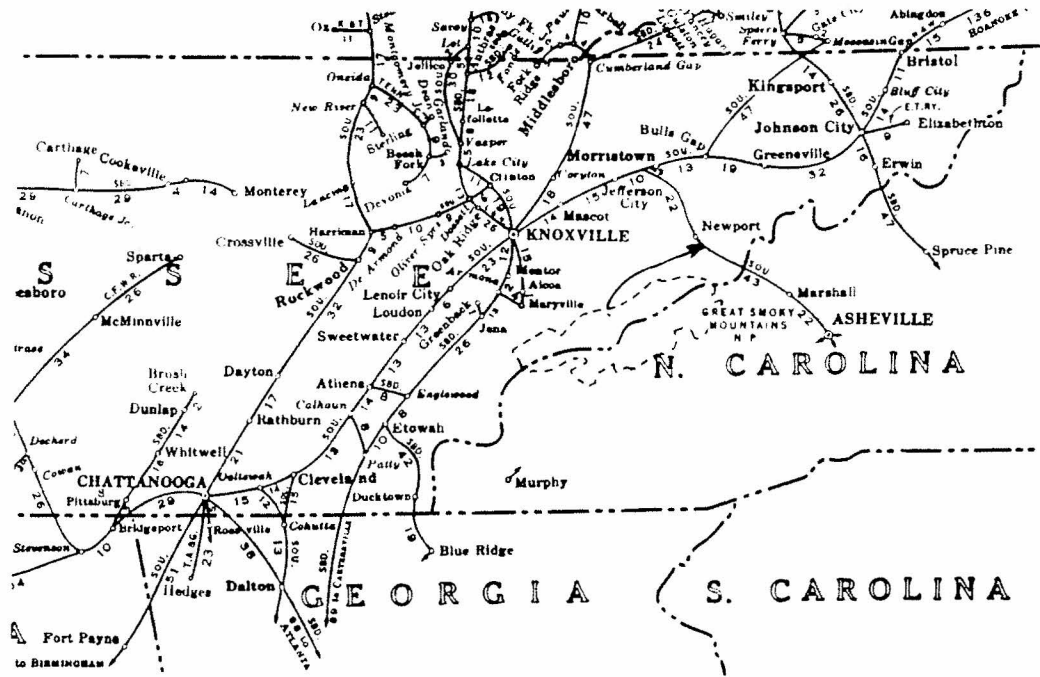
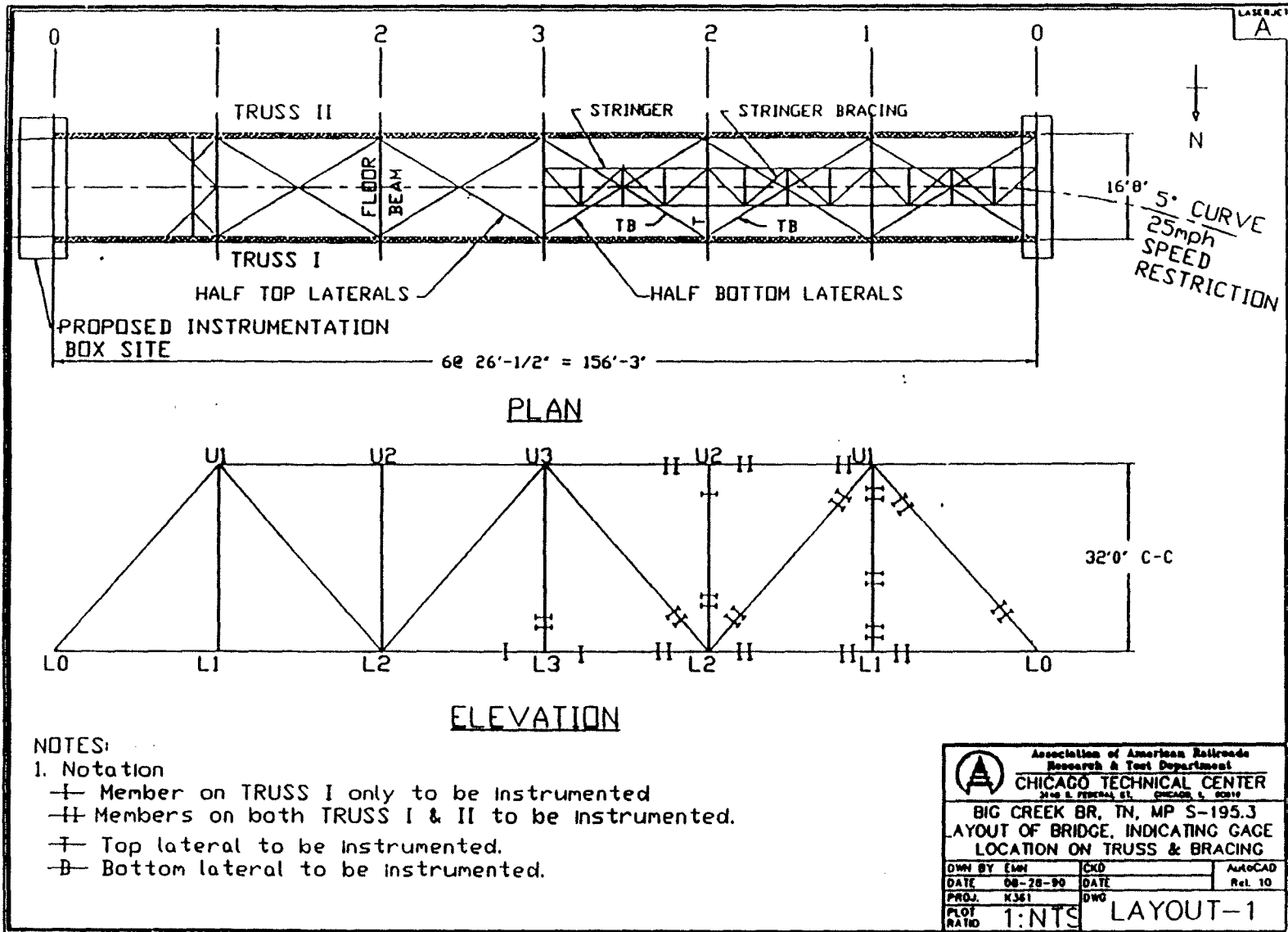

Exhibit 5. Railroad Map of the Region, and Photograph of the Test Bridge [8].



19

Exhibit 6. Schematic Layout of the Test Bridge [8].

appendix in Ref. 8. Included in this appendix are the listing and locations of data channels, table of scale factors, sectional properties of truss and floor system members, and drawings and circuit diagrams for the instrumentation.

In brief, the instrumentation as shown in Exhibit 7, included channels for the rail vertical and lateral wheel loads; stringer and floor beam end moments; top chord axial force and in-plane bending; bottom chord axial force; end post axial force; hanger for axial force and in-and-out of plane bending; diagonal for axial force and in-and-out of plane bending; top bracing for axial forces and moments; and bottom bracing for axial forces.

4.4 THE TLV TESTS

A variety of stationary, moving and forced vibration tests were made on the Big Creek Bridge. The stationary test condition included separate applications of static and steady-state dynamic vertical wheel loads; while moving condition required the application of various vertical wheel loads when moving at different speeds. In forced vibration tests, steady-state response at a wide spectrum of loading frequencies was measured to determine natural frequencies and damping of the bridge structure as a whole and its members. Tests were also made to slowly sweep the frequency range of first three modes of the bridge vibrations.

A detailed test log of the TLV tests, describing the loading condition for various tests, is given as an appendix in Ref. 8, and is not reproduced in this report. Each test procedure is, however,

TEST
(DYNAMIC)

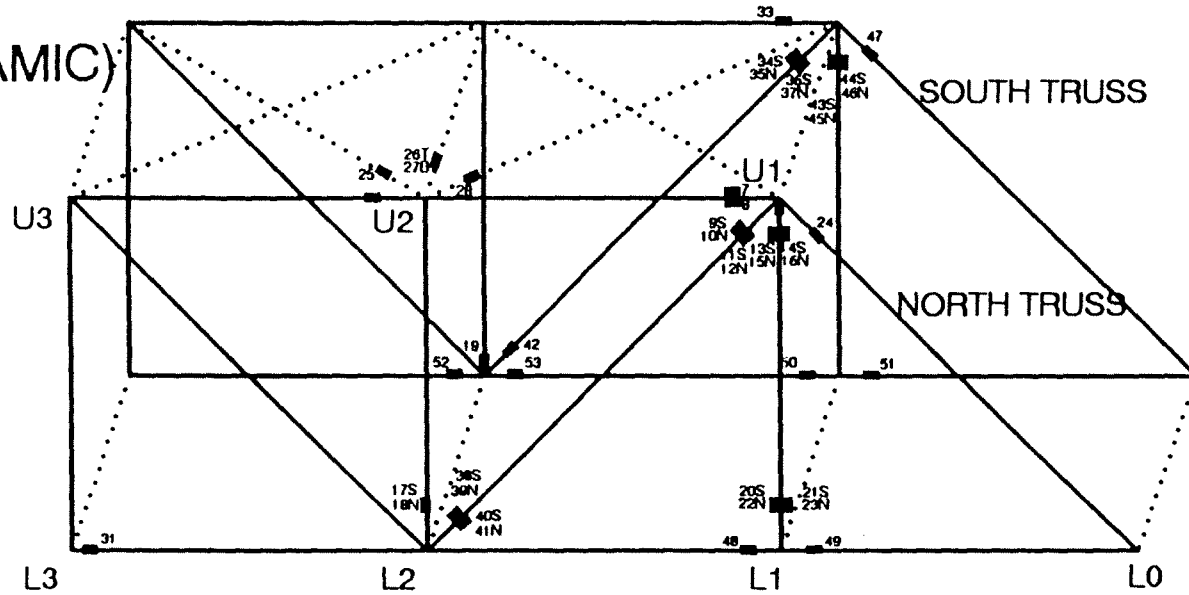

21

EAST END

WEST END

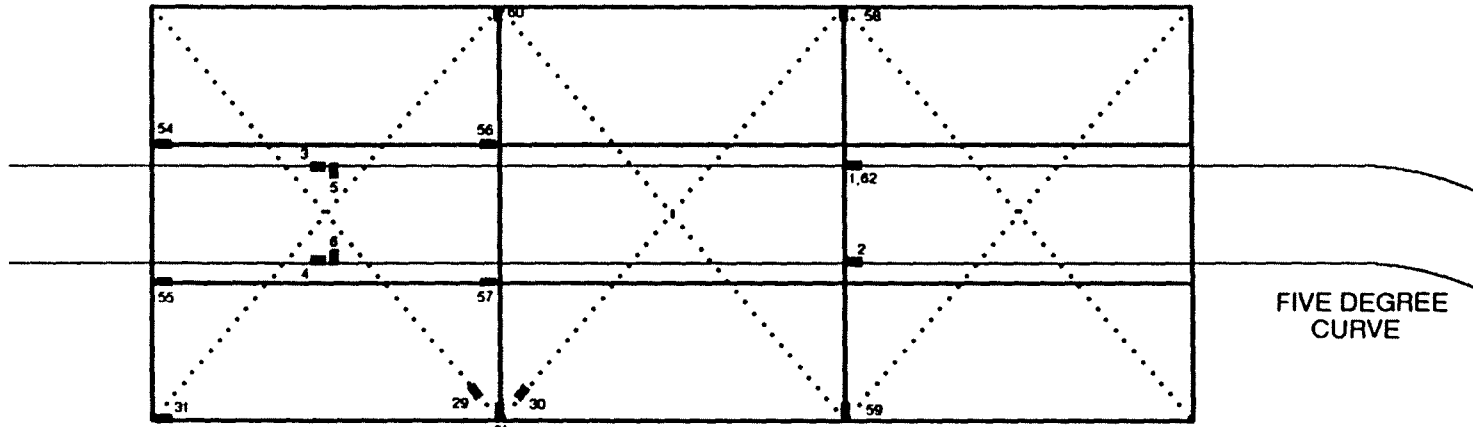

SECTIONAL HALF PLAN OF THE TRUSS FLOOR

Exhibit 7. Truss Instrumentation Plan Including Channel Locations and Numbers used in the TLV Tests [8].

described in the following sections. It should, however, be mentioned that gages were zeroed before each test to remove any thermal effect.

4.4.1 Stationary Tests

Stationary TLV tests were performed under two loading conditions, static and the steady-state dynamic. These tests were conducted under heavy axle loads applied by the bogie-wheelset. The loads were applied to rails at the bridge panel points and center of panel lengths, in succession, from east to the west end of the bridge. The load application points pertained to various positions of the TLV bogie-wheelset along span of the bridge. The center of panel length locations were included to give a sufficient number of load positions for plotting of the influence lines.

4.4.1.1 The TLV Influence Line Tests

These tests were made to determine strains in the bridge members due to static wheel loads, as the bogie-wheelset was moved across the bridge. Both 33 and 39-ton axle loads applied by the bogie-wheelset were used in these tests. Information about static stresses in the bridge members as well as a comparison with the classical analytical results were gathered. Moreover, these results were used to generate experimental influence lines of axial force in the bridge members.

A word of caution is needed regarding application of the controlled wheel loads in these tests. The test consist comprised

of a locomotive and the AAR-100 instrumentation car followed by the TLV. As such, bridge loading included not only the bogie-wheelset applied loads but also consist weight on the bridge. Also, a definite unloading of the TLV truck wheels occurred when bogie-wheelset was applying loads to the bridge. As explained in the following, the effect of the TLV consist weight was eliminated, and unloading of the TLV truck wheels was accounted for when computing the influence line or factor due to the TLV load configuration. A uniform unloading of the TLV truck wheels was assumed. According to this assumption, an unloading equal in magnitude to applied load by the bogie-wheelset was equally divided among the TLV truck wheels.

To eliminate effect of the TLV consist weight, static tests for each bogie position on the bridge were conducted in two modes: 1) no load applied by bogie-wheelset, corresponding TLV wheel load = (TLV weight)/8 and 2) a specified load, P, applied by the bogie-wheelset, corresponding TLV wheel load = (TLV weight - P)/8. As apparent, a subtraction of bridge member responses in Mode 1 from the corresponding responses in Mode 2 eliminated effects from the consist weight while retaining effects from the TLV load configuration.

Henceforth, the TLV load configuration, Exhibit 8, for each truss, is defined to consist of the weightless TLV with a series of wheel loads in the same positions as the TLV wheelsets including the bogie-wheelset. Also, the bogie-wheelset wheel load, in the TLV load configuration, will be equal and opposite to sum of the remaining four wheel loads, each of equal magnitude. The TLV load

TLV-LOAD-CONFIGURATION FOR BOGIE LOAD OF 33 KIPS

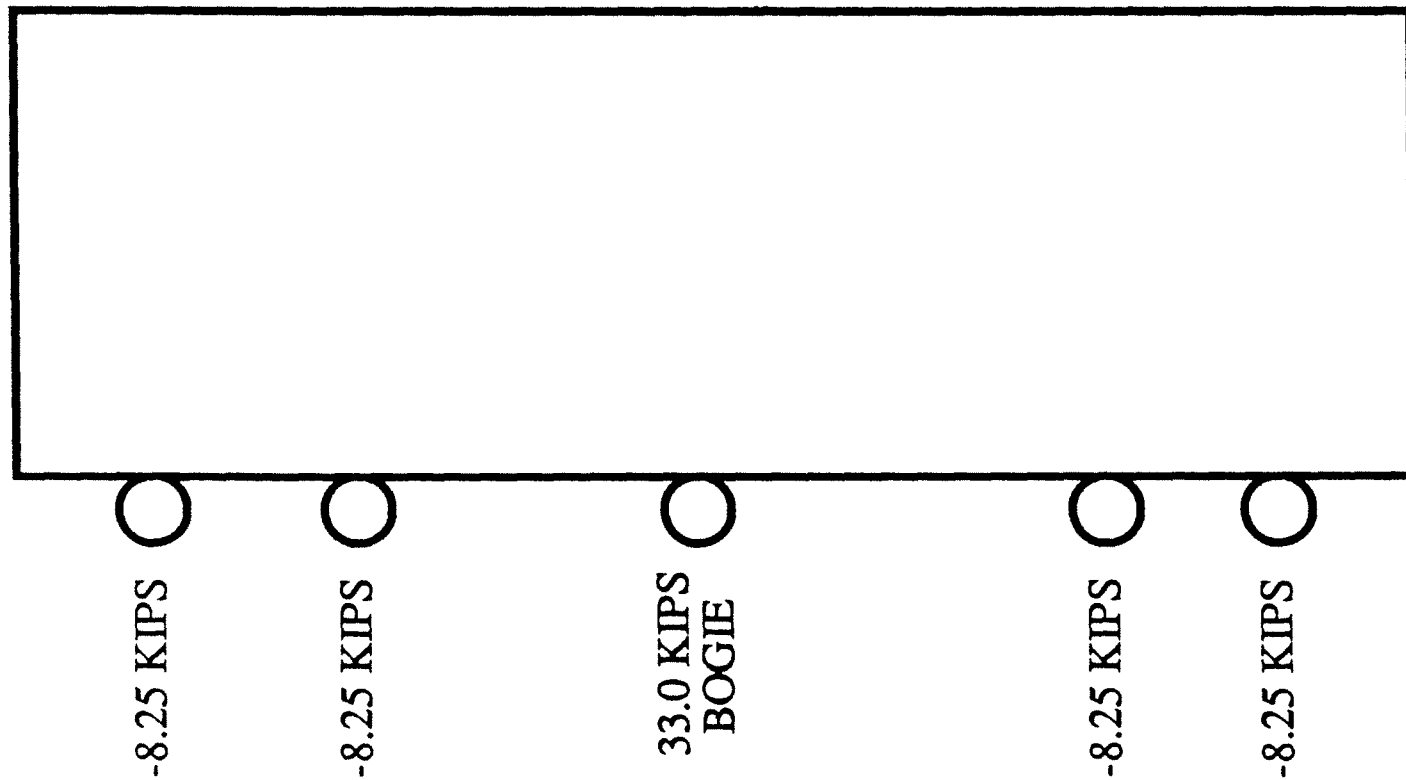

24

Exhibit 8. Schematic of the TLV Load Configuration used for the TLV Influence Lines.

configuration for influence line is assumed to have a wheel load of unity at the bogie-wheelset.

4.4.1.2 The TLV Impact Tests

American Railway Engineering Association (AREA) Manual for Railway Engineering stipulates accounting of impact load on bridges as a percentage of the live load. Furthermore, this impact load is directed in these AREA specifications to be applied vertically at top of each rail on the bridge. It is left to the designer to determine maximum effect in a bridge member due to the impact load. The impact load for bridge design therefore is treated as a rolling load which arises from the dynamics of railway cars on the bridge.

The TLV impact tests, to include vehicle dynamic effect, were an extension to the static influence line tests described above. In these tests, the bogie-wheelset was used to apply dynamic vertical wheel loads to bridge while the test consist was stationary corresponding to a loading location (panel point or the center of panel). It should be noted that mass of that portion of the TLV consist which was on bridge, in a test, would couple with the ensuing bridge vibration.

Using a typical wheel base of 70 inches for 100-ton cars, the axle load frequency, at a point on the bridge, ranges from 2.5 Hz to 6.3 Hz for train speeds from 10 to 25 mph. Similarly, using a typical truck spacing of 40 feet, frequency range for the above speeds is from 0.37 to 0.92 Hz. Resulting vehicle dynamic effects therefore, must ensue with respect to these excitation frequencies

and the particular vehicle type. The natural frequencies of vibration of heavy freight cars, empty and loaded, are in a range from about 2.5 to 6.0 Hz for pitch and bounce modes, from about 0.6 to 2.0 Hz for upper and lower roll modes, and from about 3.5 to 5.0 Hz for the twist mode.

It is, in general, expected that the track on a bridge is well maintained. Also, CWR (continuously welded rail) is generally used on bridges to reduce the vehicle excitations due to joints. In spite of all of this, a train may enter the bridge with initial conditions of bounce and pitch, rock-and-roll, and the sway and yaw motions. Due to the trial nature and limited scope of the TLV bridge tests, only a median frequency of 4 Hz, instead of the wide frequency spectrum noted above, was used. The TLV impact tests at this frequency were then conducted to simulate the effect of vehicle dynamics on the bridge due to heavy freight cars.

Correspondingly, mean wheel loads of 33 and 39 kips by the bogie-wheelset were sinusoidally applied at 4 Hz at different locations on the bridge. A dynamic amplitude of 20 percent of the respective mean wheel load was used to generate the sinusoidal load pulses. Though the TLV consist could not generate vibrations comparable to those from a real train load, a relative understanding of the magnification of stresses in bridge members, in terms of dynamic load factors from these tests, was to be gathered for each of the load positions.

4.4.2 Forced Vibration Tests

Dynamic tests of full-scale structures are generally conducted to determine such basic structural dynamic properties as natural frequencies, mode shapes and the amount of energy dissipation or damping associated with each mode. Such dynamic characteristics of the Big Creek Bridge structure were determined by conducting forced vibration tests in the frequency range up to 15 Hz. The types of forced vibration tests conducted were: 1) discrete frequency tests (resonance tests) using the steady-state sinusoidal excitation, and, 2) the variable frequency sinusoidal excitation tests (frequency sweep tests).

4.4.2.1 Resonance Tests

The steady-state resonance tests of the Big Creek Bridge were conducted by synchronized application of sinusoidally varying vertical wheel loads using the bogie-wheelset. Static vertical wheel loads of 15 kips applied at top of the L3L3 central floor beam, were sinusoidally varied at +/-5 kips at each discrete frequency of interest. Unlike the one time application of 33 or 39-kip wheel loads at a bridge location in the TLV impact tests, lower wheel loads of 15 kips at a spectrum of applied frequencies in these tests were used to maintain the wheel load pulses for a longer time.

The discrete frequency used in these tests began at 0.5 Hz, and was increased in steps of 0.5 Hz to 6 Hz. From 6 Hz to 15 Hz, the discrete frequency was varied in steps of 1 Hz. A preliminary

finite element analysis had indicated that tests up to 15 Hz will include at least first three modes of the bridge vibrations.

4.4.2.2 Frequency Sweep Tests

These tests were also conducted at the same L3L3 floor beam position as above tests, but by continuously varying the excitation frequency of sinusoidally varying loads of 15+/-5 kips applied by the bogie-wheelset. So that an appreciable amplitude of vibration was built up at each natural frequency of bridge vibrations, these tests were conducted in three frequency sweeps: 0 to 5 Hz, 5 to 10 Hz and 10 to 15 Hz. In each of the above sweeps, frequency was raised from lowest to the highest value in 250 seconds, resulting in a sweep rate of 0.02 Hz per second. It was determined that this sweep rate was small enough for a resonant peak built up to large enough magnitude.

Accelerometers on top of each interior floor beam, near its connection with the north truss, were used to measure the aggregate response of north truss. Bridge member responses were not measured in these tests.

4.4.3 Moving Tests

During moving tests, the TLV consist was moved across the bridge from east to west at speeds of 10 and 20 mph. The test procedure consisted of applying bogie vertical wheel loads of 33 and 39 kips at each speed. The effect of speed on amplification of member stresses was determined in these tests.

The second type of load application by the bogie-wheelset included an axle bounce simulation as it moved across the bridge. As noted previously in the section for TLV impact tests, bounce frequency varies from about 6.0 Hz for the empty cars to about 2.5 Hz for loaded cars. Though the TLV was capable of sinusoidally applying wheel loads between 2.5 and 6.0 Hz, it was decided for safety against bogie-wheelset derailment on the bridge to apply loads at 1 Hz while moving at 2 mph. The mean vertical bogie wheel loads of 33 kips were sinusoidally varied by +/-7 kips in the test.

(This page left blank)

5.0 TEST DATA ANALYSIS

The axial force response of some selected Big Creek Bridge members is presented in this demonstration study. The analysis was carried out for hanger L1U1, diagonal L2U1, end post L0U1, top chord U1U2, and the bottom chords L0L1 and L1L2. Results of each test are given in the following subsections.

5.1 STATIONARY TEST RESULTS

It was expected that a comparison of theoretically calculated primary member stresses with those from the TLV tests would clarify extent of the secondary stresses due to rigid joint connections. Also, it was expected that an experimental static influence line for any selected bridge member would be obtained using the TLV load configuration. This would then lead to an assessment of the actual force distribution among various members. Moreover, dynamic augments would be determined from magnification of member stresses in the TLV impact tests.

5.1.1 The TLV Influence Line Results

First of all, the theoretical (primary) and experimental axial force responses of various bridge members to the full TLV test consist loading are compared. As an aid to determining the theoretical responses of bridge members, theoretical influence lines for the critical members are given in Exhibits 9 and 10.

Typical strain histories in hanger L1U1, when bogie-wheelset loads of 0, 33 and 39 tons were applied at floor beam L1L1 on west

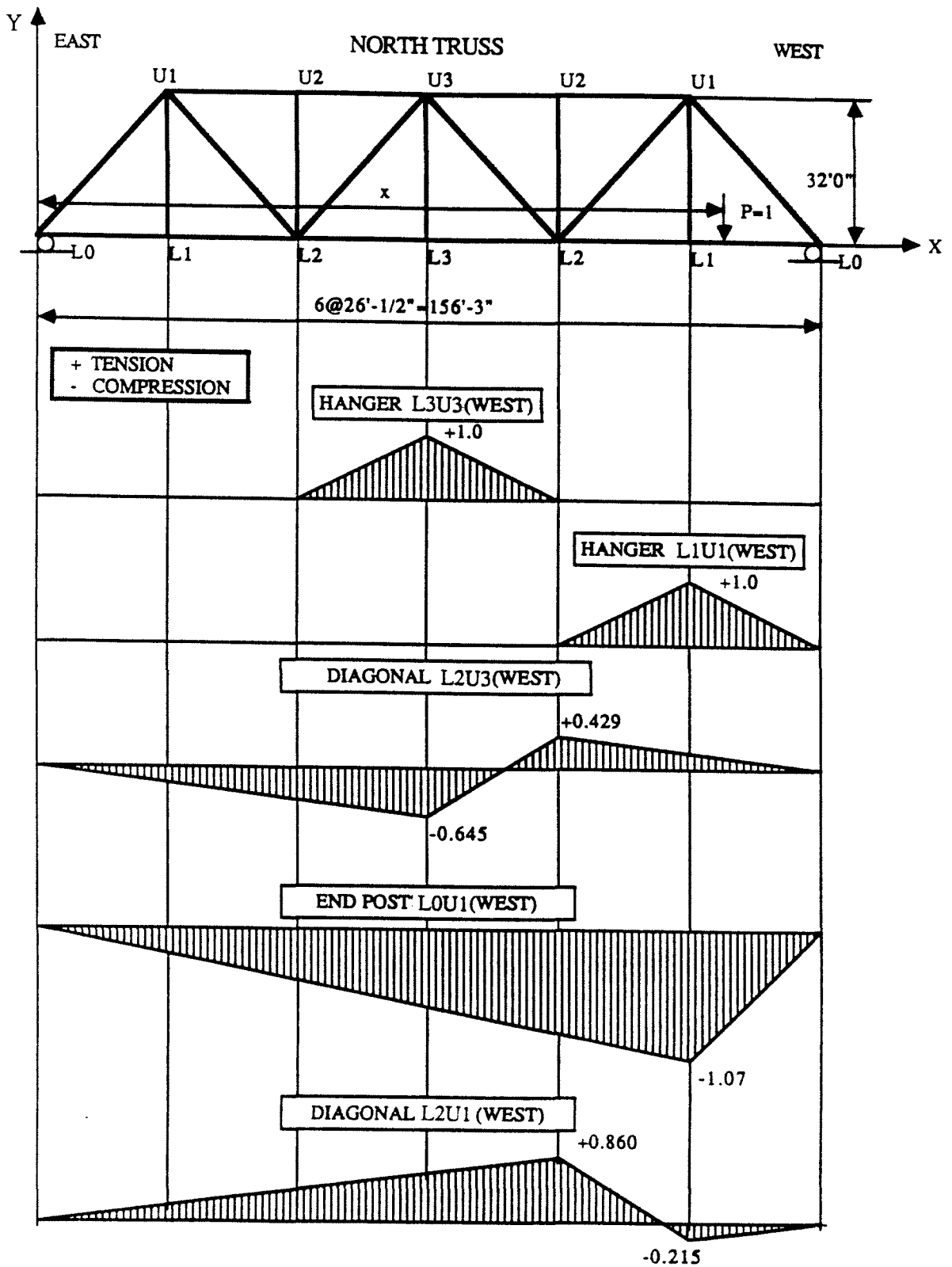

Exhibit 9. Axial Force Theoretical Influence Lines of Truss Web Members.

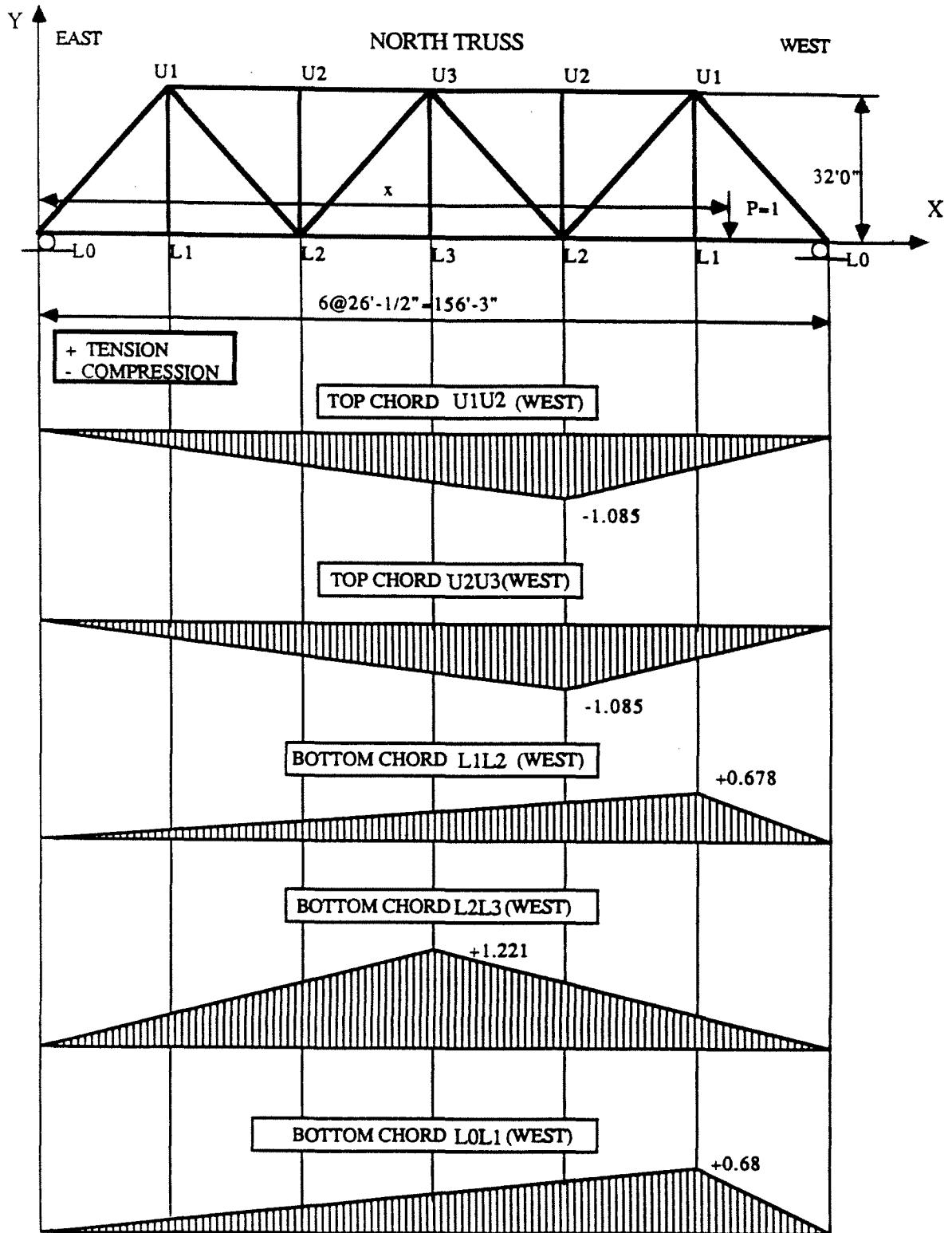

Exhibit 10. Axial Force Theoretical Influence Lines of Truss Top and Bottom Chord Members.

half of the bridge, are given in Exhibits 11, 12 and 13, respectively. The corresponding hanger axial strain response was obtained by taking the average of strain readings from Channels 13, 14, 15 and 16. These axial strain responses are shown, in exhibits, as the "ave. of channels" histories.

The axial forces in north truss members with the bogie-wheelset midway on west bridge panel L2L3 are shown in Exhibits 14, 15 and 16. Exhibit 14 shows the axial forces resulting from Mode 1 loading when bogie-wheelset did not apply any vertical load to the bridge. Exhibits 15 and 16 give results for Mode 2 loading when the bogie-wheelset first applied 33 and then 39 tons of vertical loads, respectively. A complete set of north truss axial force exhibits for Mode 2 loading under 39 tons is given in Appendix A.

The position of bogie-wheelset in these exhibits is marked "bogie" on the bridge sketch; and is also described in terms of distance with respect to the east panel point L0. Test consist wheel loads, in kips, are noted in the sketch. Axial forces in the truss members are compressive if negative and tensile if positive. Also the axial forces in parentheses are from the tests. The east and west truss reactions, and the floor beam reactions, given in the exhibits, are only from the theoretical analysis of truss. Positions of the TLV, AAR-100 instrumentation car, and the locomotive, only within the bridge confines, are drawn and labelled in the exhibits.

An examination of bridge response in the static tests showed

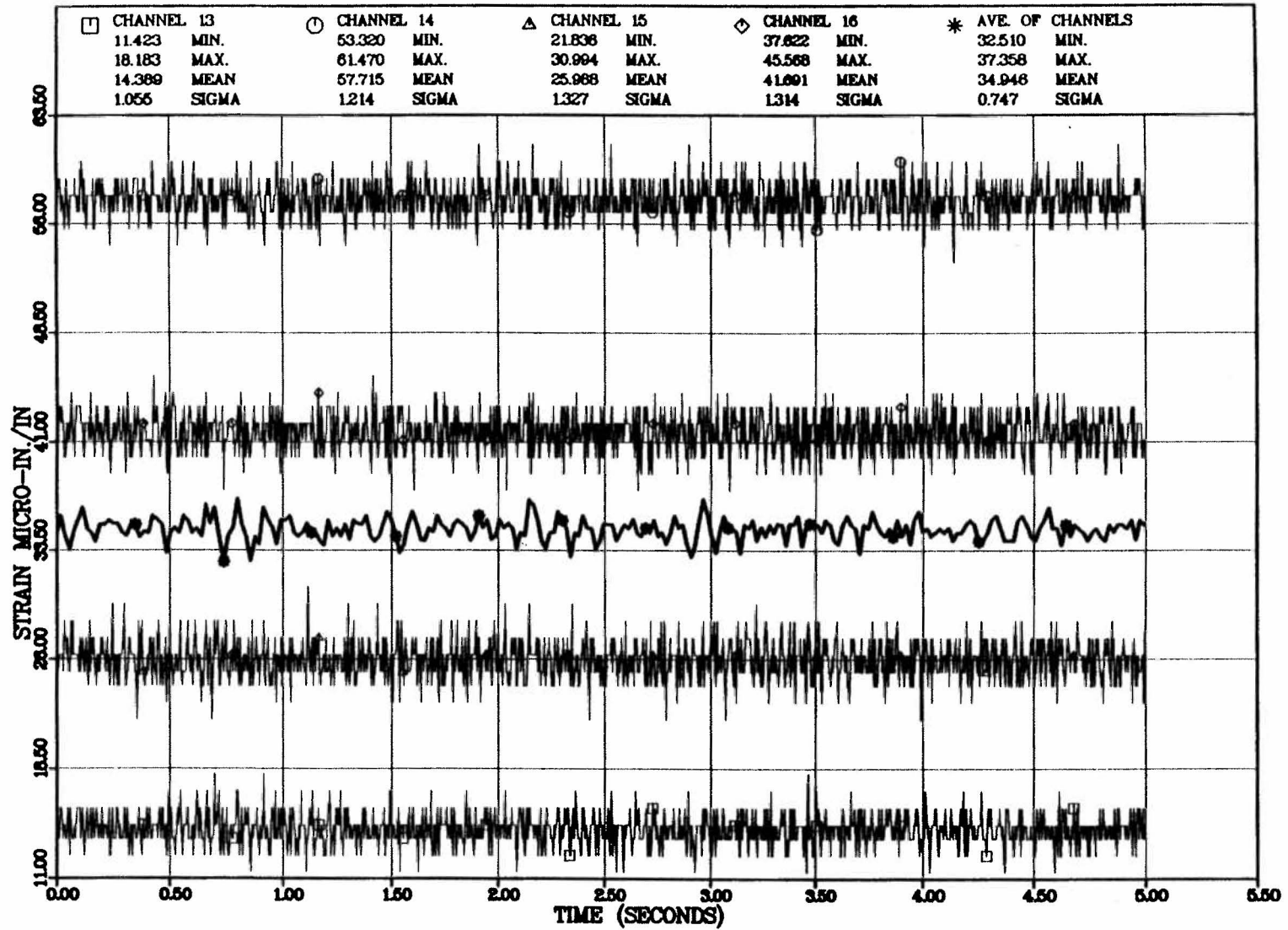

Exhibit 11. Strain Histories in West Hanger L1U1 (Upper End) of North Truss due to the Stationary TLV Test Consist with Bogie-Wheelset Static Load of 0.0 Tons Applied on West Floor Beam L1L1.

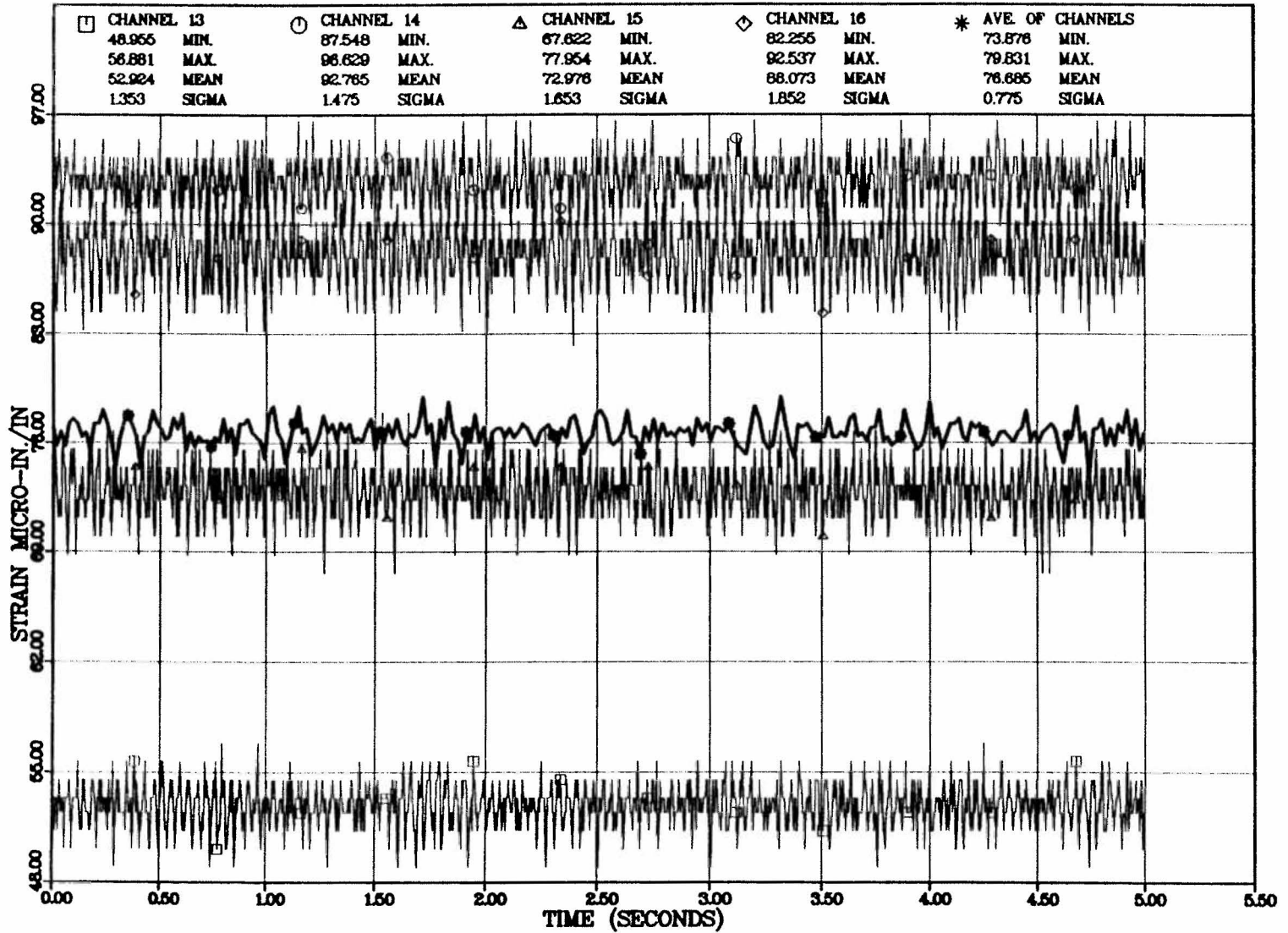
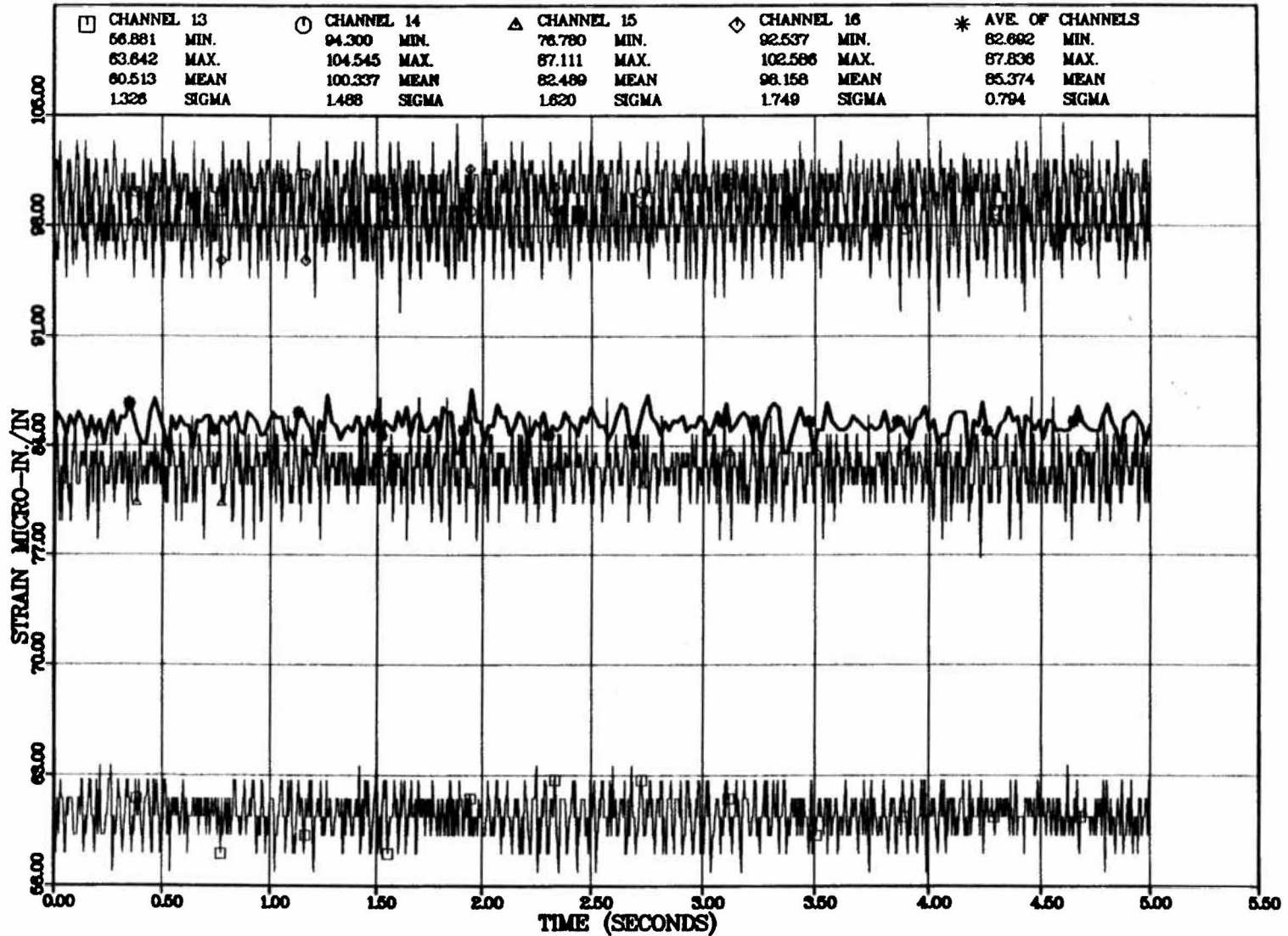

Exhibit 12. Strain Histories in West Hanger L1U1 (Upper End) of North Truss due to the Stationary TLV Test Consist with Bogie-Wheelset Static Load of 33 Tons Applied on West Floor Beam L1L1.



37

Exhibit 13. Strain Histories in West Hanger L1U1 (Upper End) of North Truss due to the Stationary TLV Test Consist with Bogie-Wheelset Static Load of 39 Tons Applied on West Floor Beam L1L1.

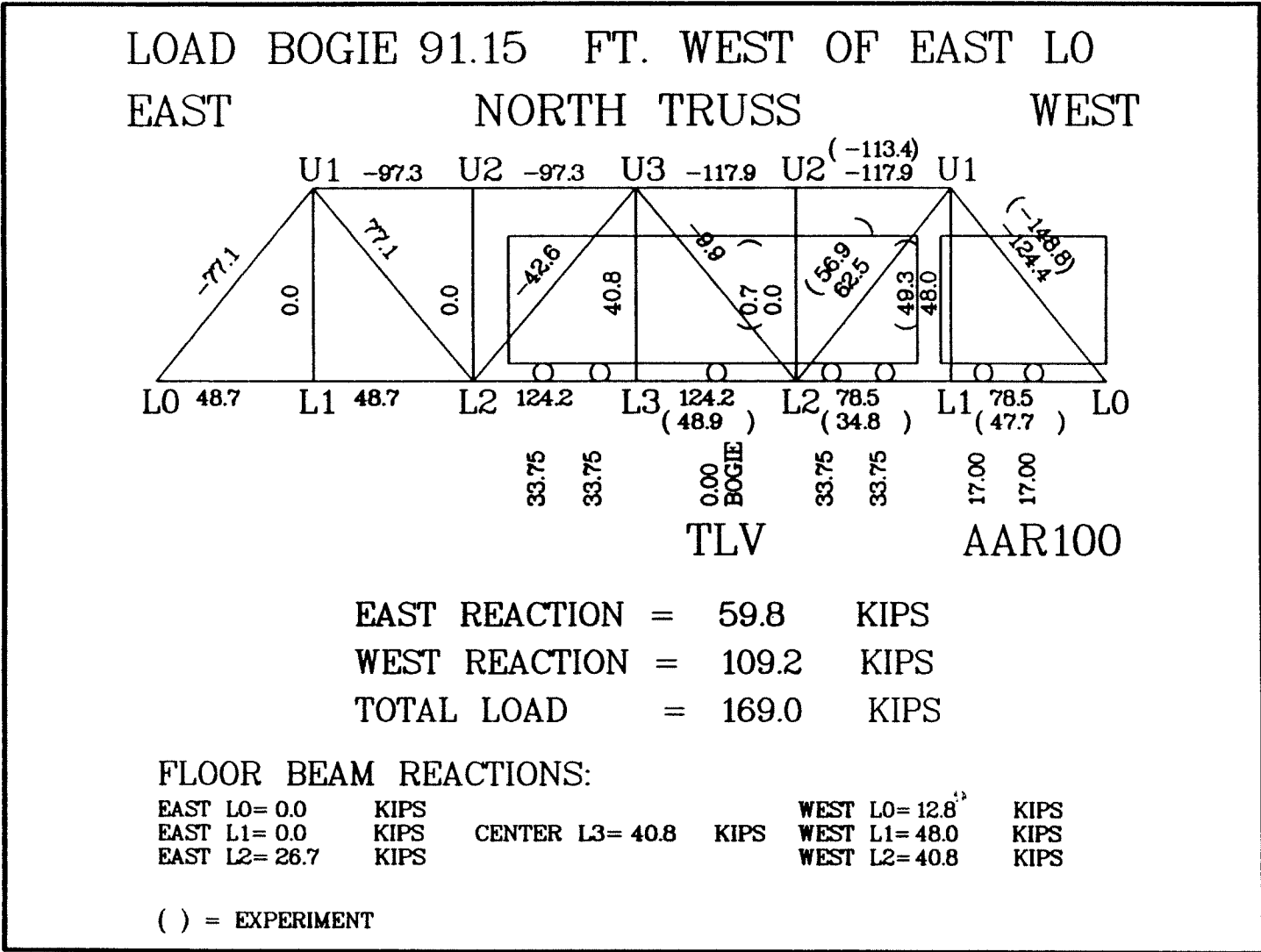

Exhibit 14. Theoretical and Experimental Axial Forces in North Truss Members due to the Stationary TLV Test Consist with Bogie-Wheelset Static Load of 0.0 Tons Applied on West Bridge Panel L2L3.

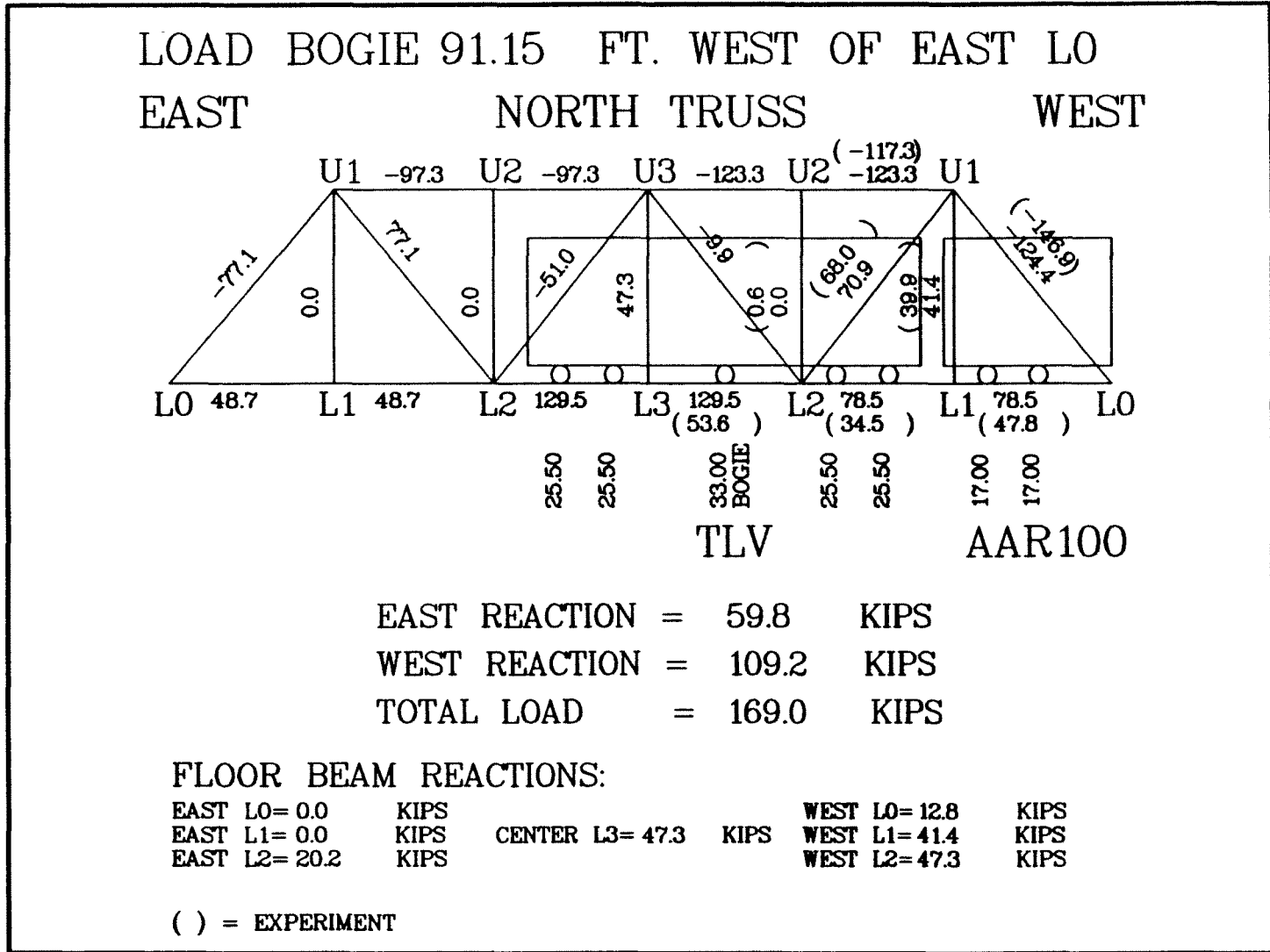

Exhibit 15. Theoretical and Experimental Axial Forces in North Truss Members due to the Stationary TLV Test Consist with Bogie-Wheelset Static Load of 33 Tons Applied on West Bridge Panel L2L3.

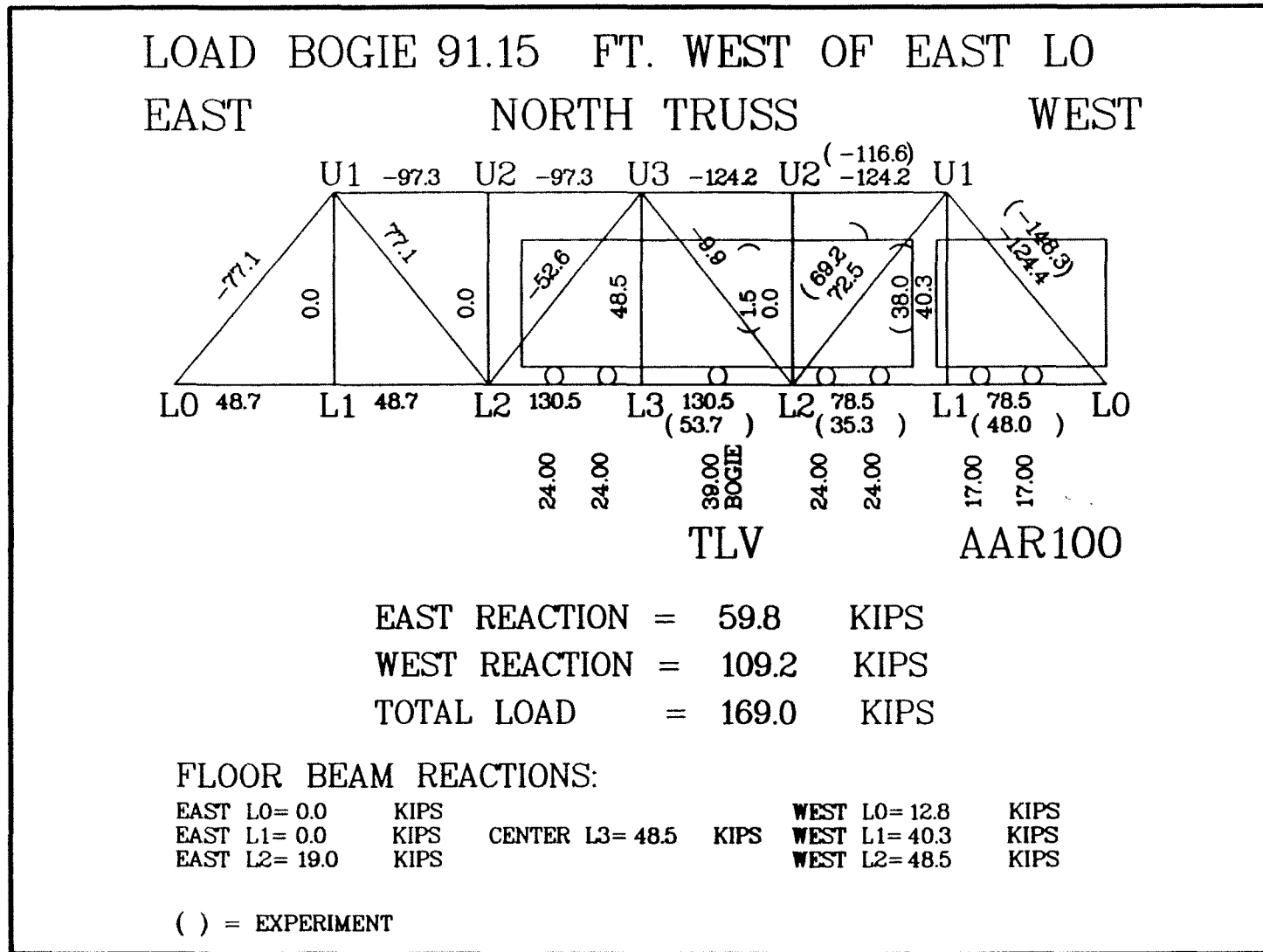

Exhibit 16. Theoretical and Experimental Axial Forces in North Truss Members due to the Stationary TLV Test Consist with Bogie-Wheelset Static Load of 39 Tons Applied on West Bridge Panel L2L3.

that axial forces in top chord and web members such as hangers, diagonals, and the end posts, were quite close to each other between test and the theory. In the bottom chord however, the axial forces were substantially lower than those given by the theory. It appeared that such a difference in the test results could occur due to two basic reasons: 1) close proximity of strain gages and higher overall bending at lower chord joints, and 2) out of plane bending, and sharing of forces at joints due to framing action of the floor system and bottom bracing with the bottom chord. A case of such a drastic difference between theory and the test results, in bottom chord, is shown in Exhibit 17 for one of the static load cases on south truss. It is suggested that bottom chord should be instrumented near the center of its panel length for axial force tests.

Furthermore, the vertical member L2U2 connecting at right angles to top chord could, in theory, not sustain any axial force. Test results in Exhibits 14 to 16, however, showed that this member shared in supporting the consist load on bridge. It was believed that the discrepancies between theoretical and the test results arose due to semi-rigidity of the truss connections. The connections, generally analyzed to allow free rotation, caused a redistribution of applied loads through the structure. Secondly, misalignment of members in comparison to the design drawings would also lead to some differences in theoretical and the test results.

Theoretical and test axial forces from application of the TLV load configuration are shown in Exhibits 18 and 19. The results

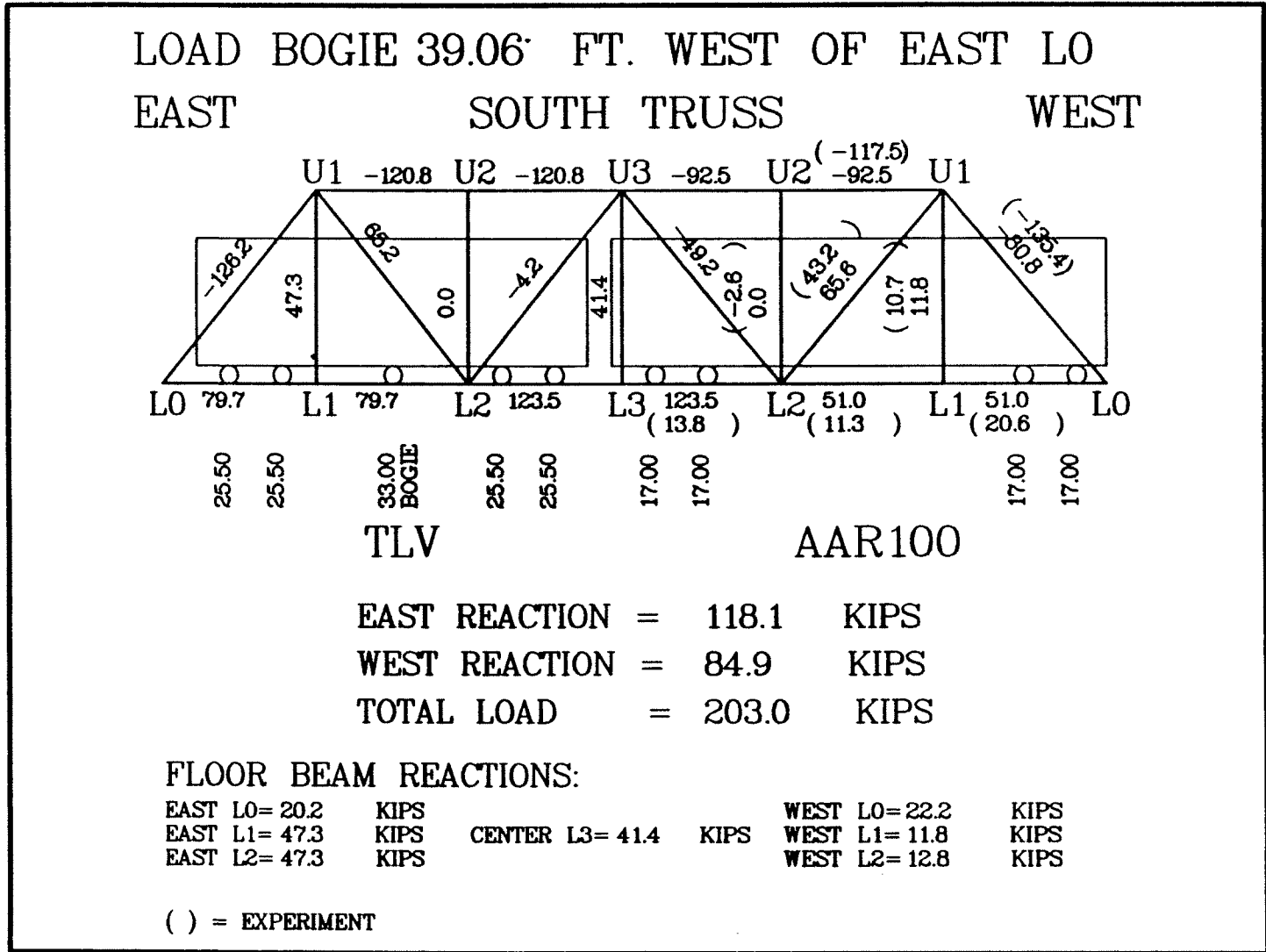
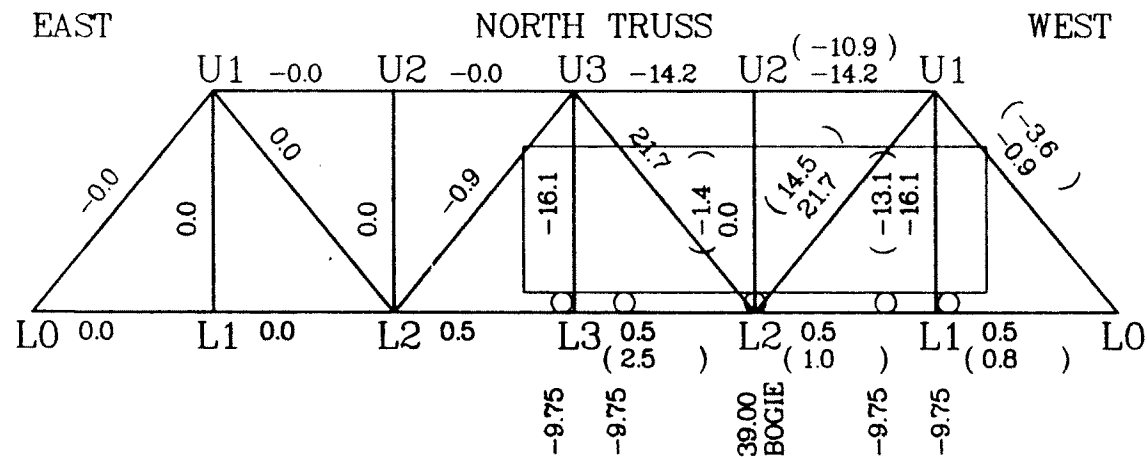

Exhibit 17. Theoretical and Experimental Axial Forces in South Truss Members due to the Stationary TLV Test Consist with Bogie-Wheelset Static Load of 33 Tons Applied on East Bridge Panel L1L2.

LOAD BOGIE 104.17 FT. WEST OF EAST L0



TLV

EAST REACTION = 0.00 KIPS
 WEST REACTION = -0.00 KIPS
 TOTAL LOAD = 0.00 KIPS

FLOOR BEAM REACTIONS:

EAST L0= 0.0	KIPS	CENTER L3= -16.1	KIPS	WEST L0= -0.7	KIPS
EAST L1= 0.0	KIPS			WEST L1= -16.1	KIPS
EAST L2= -0.7	KIPS			WEST L2= 33.6	KIPS

() = EXPERIMENT

Exhibit 19. Theoretical and Experimental Axial Forces in North Truss Members due to the Stationary TLV Load Configuration with Bogie-Wheelset Static Load of 39 Tons Applied on West Floor Beam L2L2.

in Exhibit 18 correspond to the bogie load per truss of 33 kips and in Exhibit 19 to 39 kips. Explanatory notes, given in conjunction with previous exhibits for the full consist load, also apply to these exhibits. As evident in these exhibits, isolation of the bogie-wheelset applied loads from consist weights results in a net upward loading on the TLV truck wheels. This net upward loading on each of the TLV truck wheels is equal to one-fourth of the wheel load applied by the bogie-wheelset. Again, the discrepancy between theoretical and the experimental axial forces in these exhibits is attributable to rigid connections in the truss and a possible unequal unloading of the TLV trucks.

As evident from Exhibits 18 and 19, accompanied unloading at the TLV trucks imposes certain physical limits on bridge tests by using the TLV. If unloading at the TLV trucks is not to affect results, then a bridge of span length less than the distance between inside wheels of the TLV trucks can only be tested for stresses/defects. For a truss hanger, this limitation will imply a panel length on each side of the hanger as being less than one-half the distance between inside wheels of the TLV trucks. Otherwise, alternative methods need to be found, such that any train load on any bridge could be synthesized from the use of influence lines created using the TLV load configuration concept.

Such axial force influence lines are shown in Exhibits 20 and 21 for diagonal L2U1 and hanger L1U1, respectively, of the north truss. Similar influence lines for top and bottom chord members and end posts of both the north and south trusses are given in

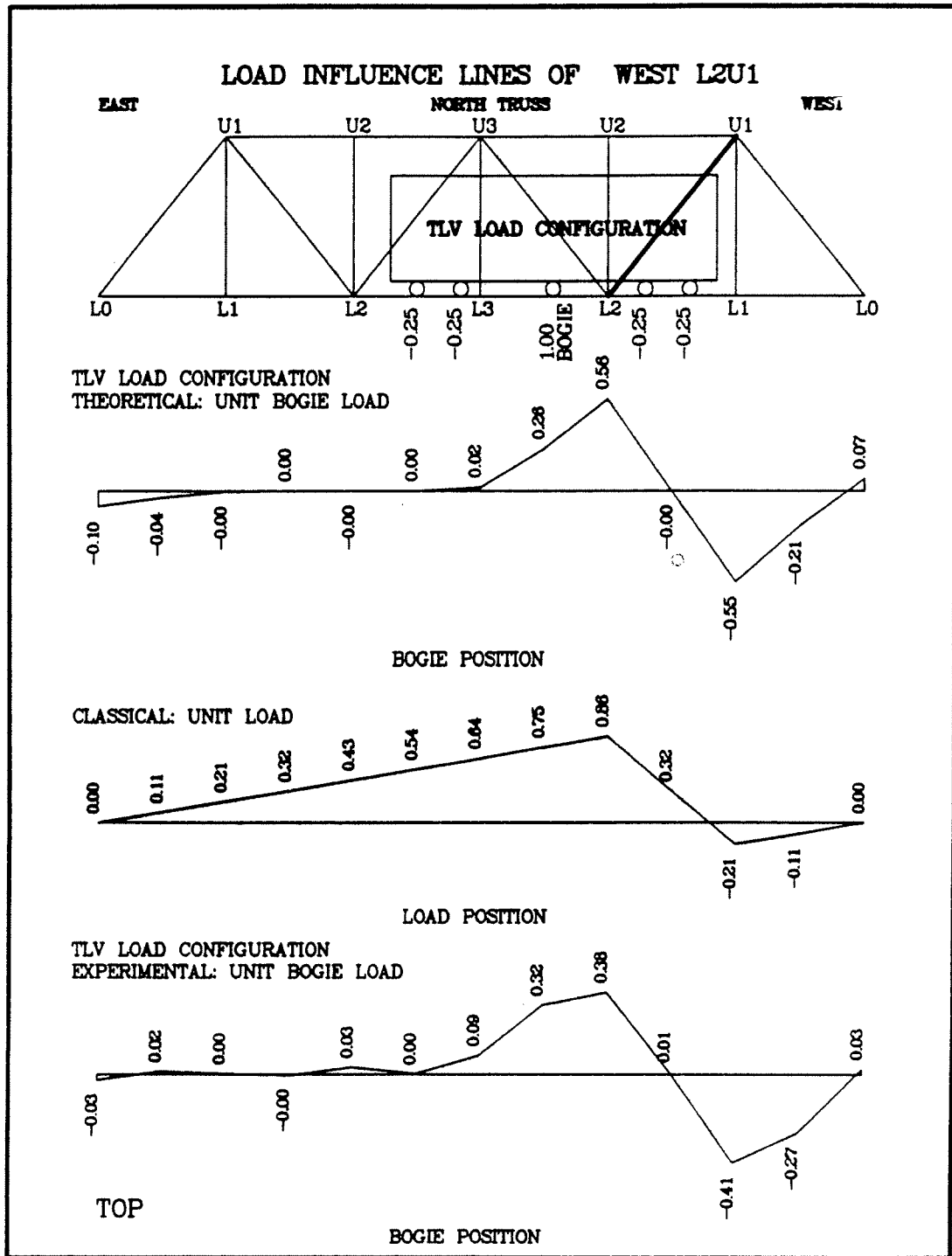

Exhibit 20. Influence Lines of Axial Force in West Diagonal L2U1 of North Truss by Using the TLV Load Configuration Concept.

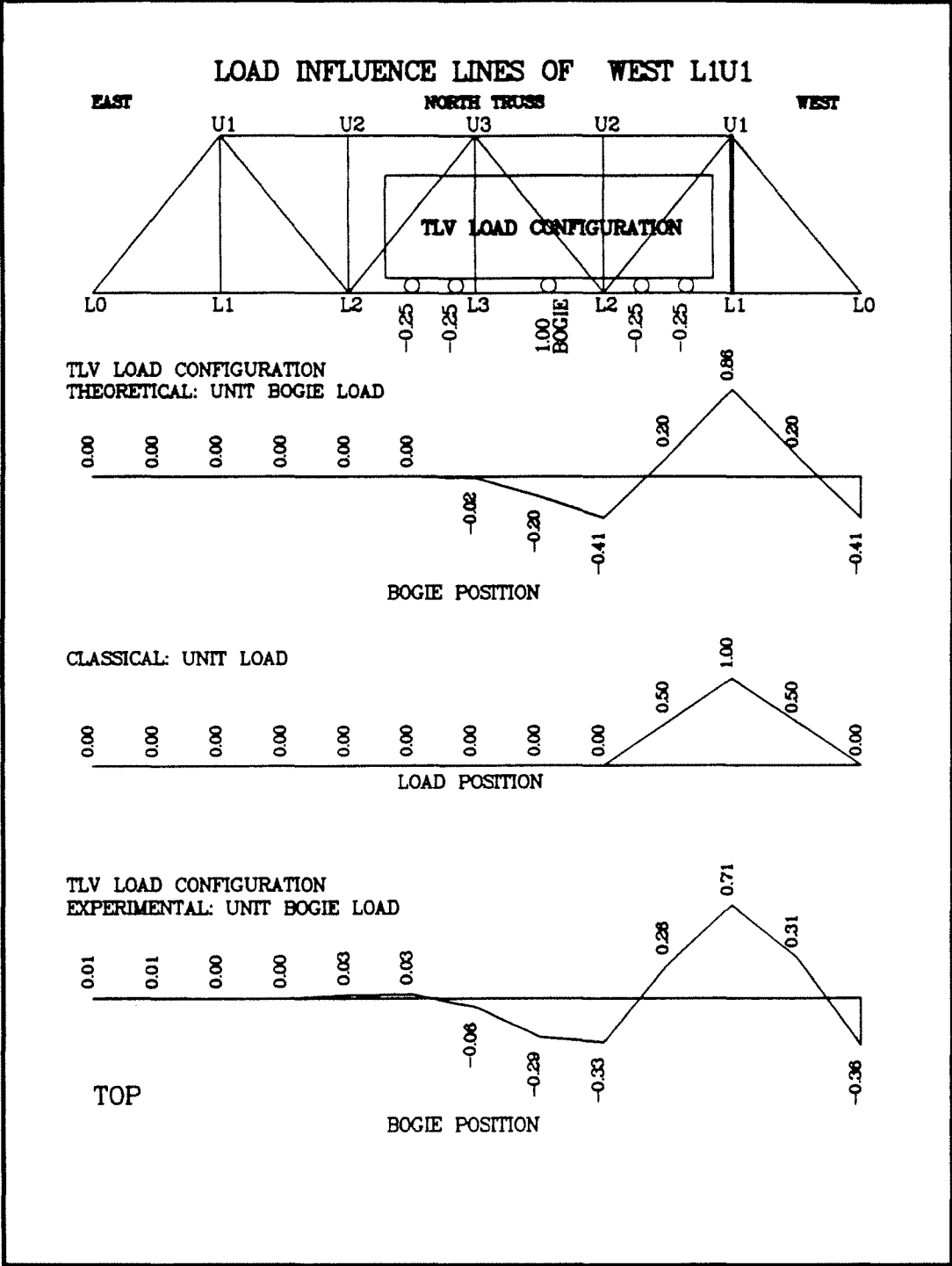

Exhibit 21. Influence Lines of Axial Force in West Hanger L1U1 of North Truss by Using the TLV Load Configuration Concept.

Appendix B. The "top" or "bottom" or "left" or "right" label, at bottom, on left hand side in exhibits refers to location of strain gage channel/s along the length of a member. The corresponding channels were used in the analysis of experimental data for the respective member.

The middle graph in each influence line exhibit shows the customary (classical) axial force influence line for highlighted member in the truss sketch. This graph represents axial force in the highlighted member when a unit load traverses the bridge span. Using this customary influence line and superposition, the TLV theoretical influence line for highlighted member, is derived due to passage of the TLV load configuration on bridge. The TLV theoretical influence line is given as the first graph in the respective exhibit. The last graph in these exhibits is derived from test results. Also, like first graph, the last graph gives axial force in highlighted member as the TLV load configuration moves across the bridge span.

It is postulated that force in a truss member due to any one wheel load at any position on bridge can be found by a recurrent application of the respective TLV experimental influence line, similar to last graph in the influence line exhibits. The recurrence of influence line application is needed due to the idealization of any one wheel load on bridge according to a sequence of TLV load configurations. That is, any one load on bridge is assumed to be the bogie wheel load accompanied with equal and opposite loads, each one-fourth the magnitude of the bogie

wheel load, applied at locations corresponding to the TLV truck wheels.

In the above idealization, the combination of bogie load and the TLV truck wheel loads which are in opposition to bogie load make the first of a series of equivalent TLV load configurations. The unused TLV truck wheel loads which are in the same direction as bogie load constitute remainder of the one wheel load being simulated, and are in turn converted into other equivalent TLV load configurations. The remainder from each previous idealization is treated in a similar manner. Such an idealization of any one wheel load on bridge into a series of equivalent TLV load configurations then makes application of the TLV experimental influence line possible in discerning the corresponding effect in a bridge member. And the effect in a bridge member of each such wheel load on bridge thus can be accumulated.

It is to be noted that a superposition of results from a series of idealized TLV load configurations and corresponding TLV experimental influence lines is implied. In spite of this linear combination of results, the method can not be construed to only represent a linear bridge response. This is so because the TLV experimental influence lines are used in the superposition of responses.

As might now be apparent, the idealization of any one wheel load on bridge into a series of equivalent TLV load configurations, has a load-fanning effect across the bridge span. Some portion of the idealized wheel load may thus spill out of the bridge span. In

each recurrence, the idealized load at bogie-wheelset generates a remainder of one-fourth of the bogie load. Since each cycle of application of the TLV experimental influence line diminishes the accompanied remainder by a factor of four, it is believed that any spillage that may occur due to the ensuing load-fanning effect will be insignificant. It is estimated that effect in a member of any one wheel load on a bridge, with proper augmentation for dynamic effect of speed, can adequately be represented by a recurrent application of the respective TLV influence line.

5.1.2 The TLV Impact Test Results

As mentioned in Section 4.4.1.2, results of these tests are preliminary, and have a limited application due to the trial nature and limited scope of the tests. At best, a relative comparison of dynamic axial force amplifications in bridge members, at the one test load frequency used, be made from these tests.

The results are presented as a set of typical strain time histories in hanger L1U1 in Exhibit 22. Explanation of channels in the exhibit is same as that given earlier under the static influence line results. The results from these tests were used to determine percentage differences of maximum dynamic axial forces in members from the corresponding maximum static axial forces as impact percentages.

The impact percentages for hanger L1U1 and diagonal L2U1 of north truss, with respect to various positions of bogie-wheelset on the bridge, are shown in Exhibits 23 and 24. The impact percentage

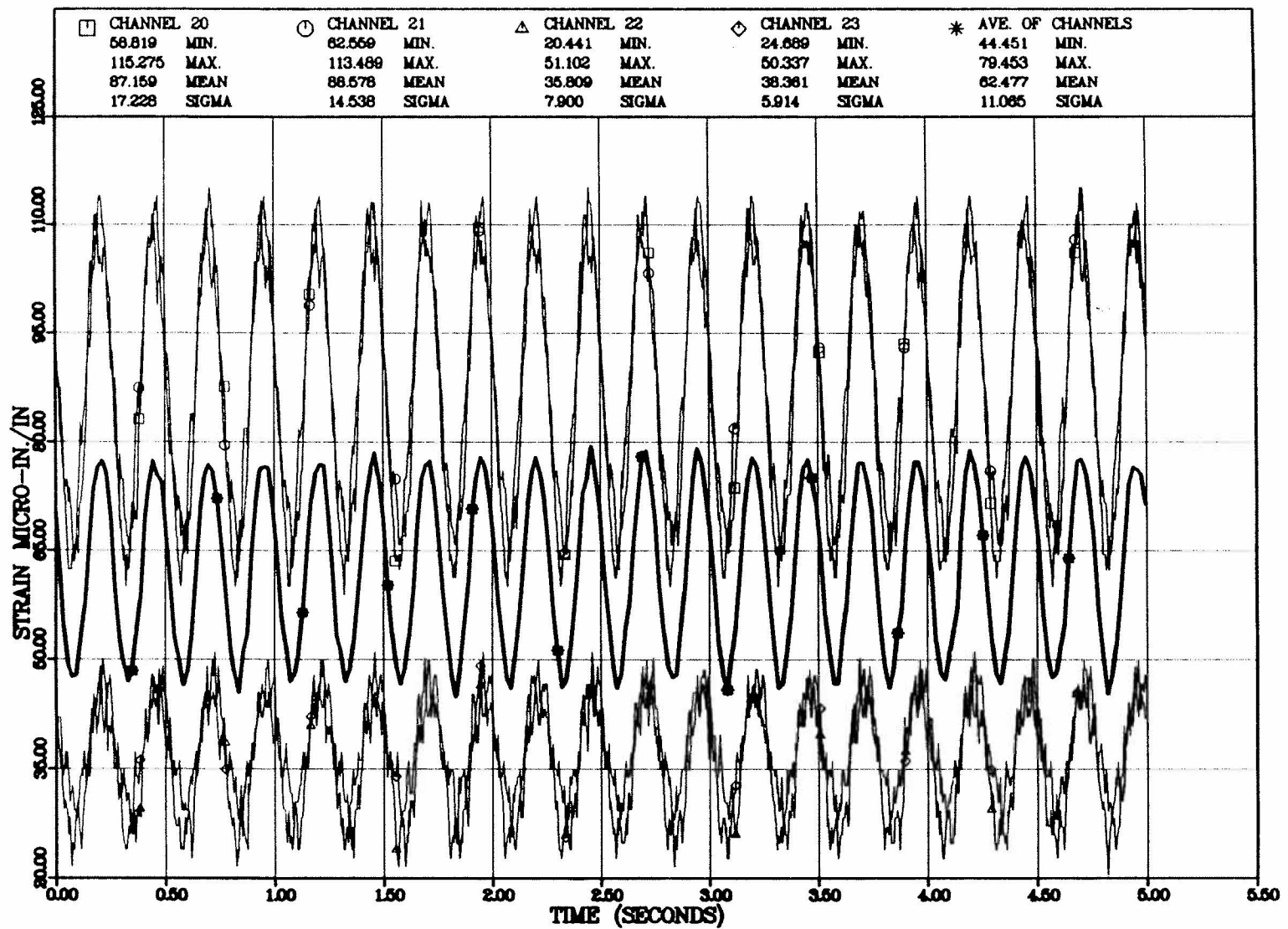

Exhibit 22. Strain Histories in West Hanger L1U1 (Lower End) of North Truss due to the Stationary TLV Test Consist with Bogie-Wheelset Sinusoidal Load of 33+/-7 Tons at 4 Hz Applied on West Floor Beam L1L1.

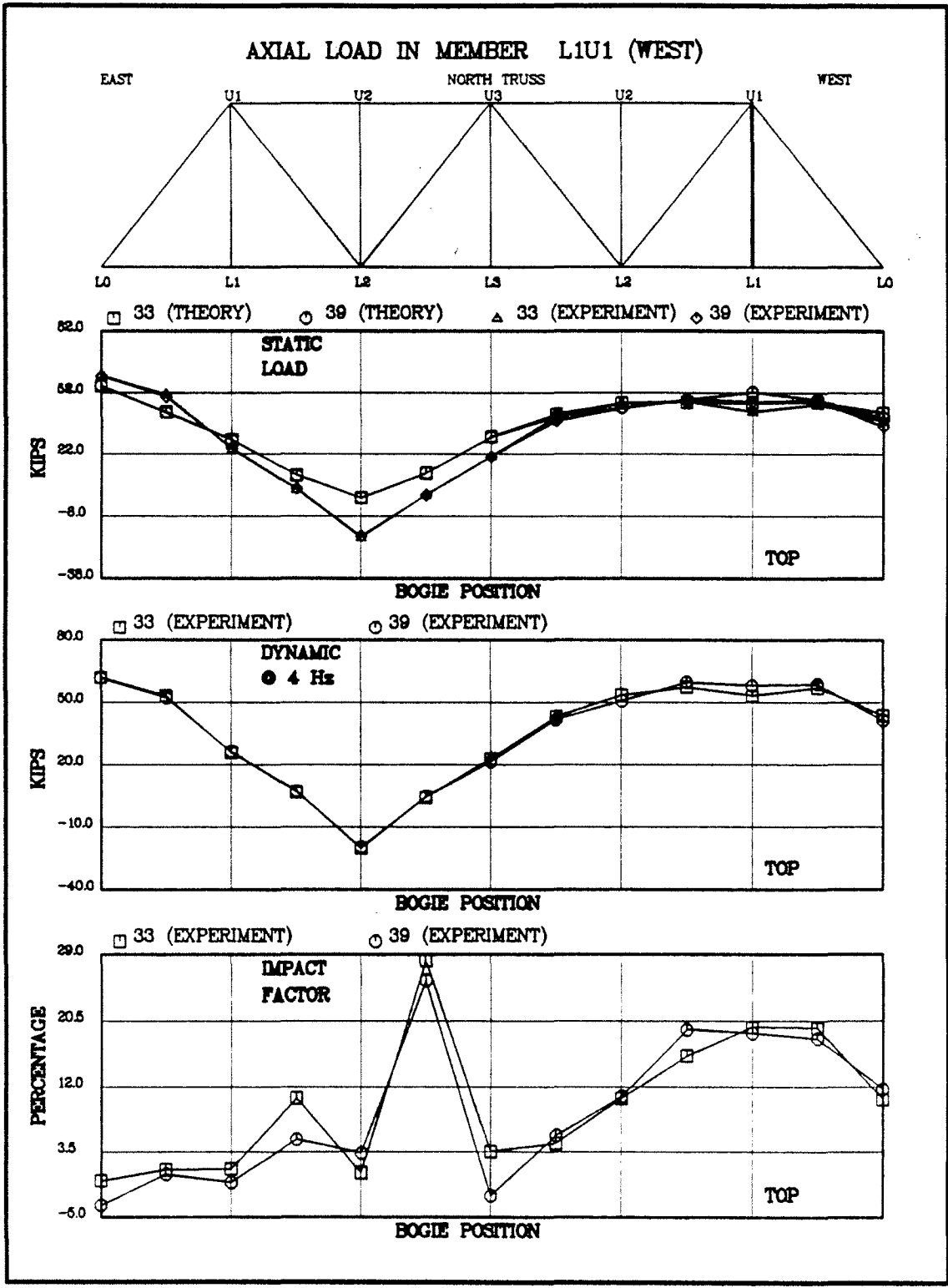

Exhibit 23. Variation of Impact Percentages and Maximum Axial Forces in West Hanger L1U1 (Upper End) of North Truss due to the TLV Consist at Various Locations on the Bridge.

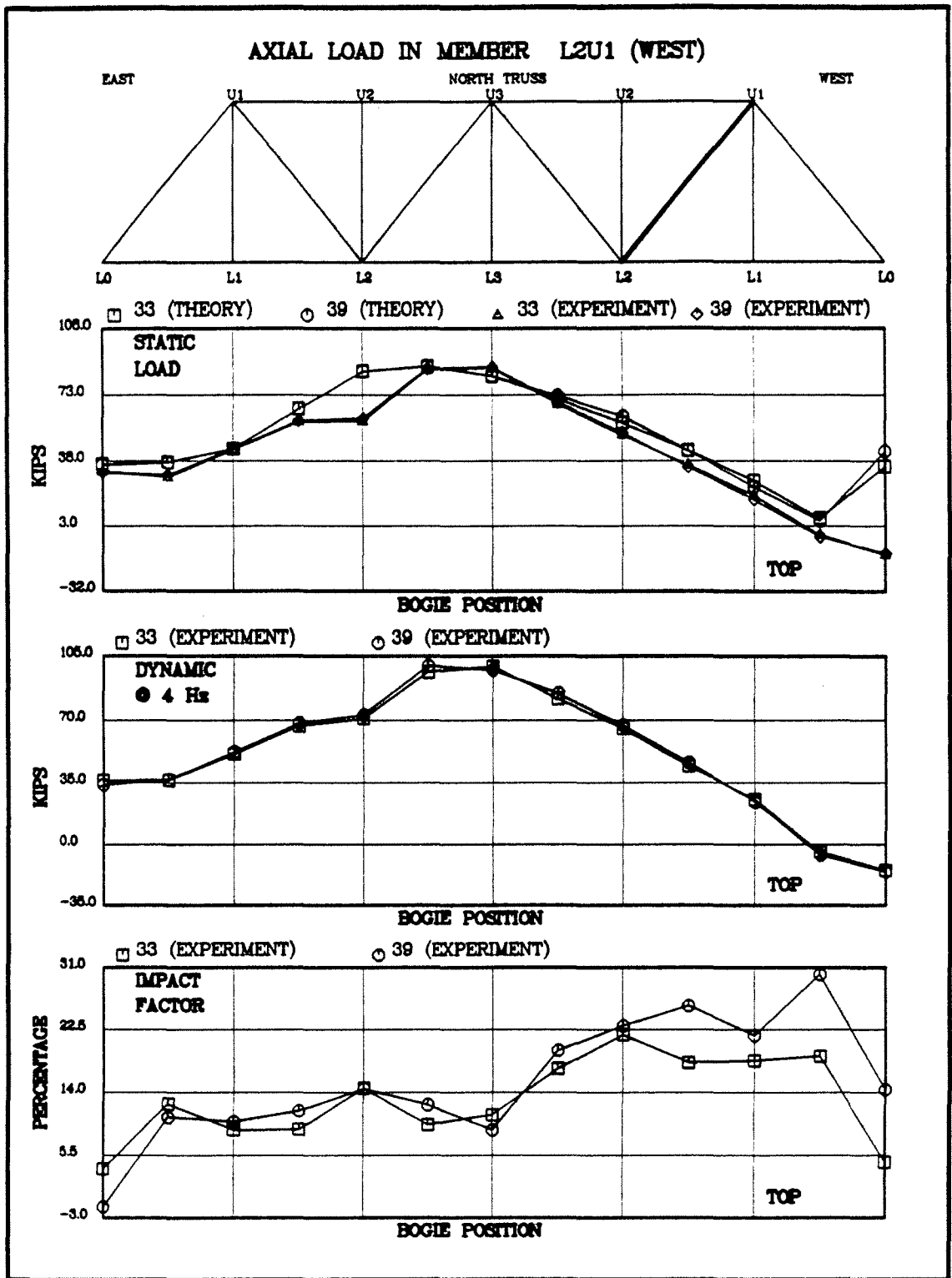

Exhibit 24. Variation of Impact Percentages and Maximum Axial Forces in West Diagonal L2U1 (Upper End) of North Truss due to the TLV Consist at Various Locations on the Bridge.

exhibits for other members are given in Appendix C. The member to which results apply is highlighted in each of the exhibits. "Top", "bottom", "left", or "right" labels on right hand side in exhibits refer to physical location of strain gage channels on the highlighted member. The static and dynamic axial forces in highlighted member are also given in these exhibits.

A maximum impact percentage of about 28 in hanger and about 30 in diagonal is evident in Exhibits 23 and 24, respectively. The corresponding maximum dynamic and static axial forces in hanger were 4.26 and 3.32 kips, respectively, with respect to bogie-wheelset position mid-way between panel points L2 and L3 on east side of the bridge. Also, the mean dynamic wheel loads applied by bogie-wheelset were 33 kips each, while rest of the test consist was on west side of the bridge. Similarly, the maximum dynamic and static axial forces in diagonal were -6.21 and -4.78 kips, respectively, and pertained to 39 kip dynamic wheel load applied by the bogie-wheelset. The corresponding position of the bogie-wheelset was mid-way between panel points L0 and L1 on west side of the bridge.

As is apparent from a study of impact percentages and corresponding axial forces, the occurrence of maximum impact percentage might not coincide with maximum response of the member to loads. In fact, the maximum axial force in hanger L1U1 in these tests occurred at its upper end when position of 33-ton bogie-wheelset load was at floor beam L0L0 on east side of the bridge. The corresponding maximum dynamic and static axial forces in hanger

were 61.88 and 62.05 kips, respectively, and gave a negative impact percentage of 0.27. The negative impact percentage occurred because dynamic response was lower than the corresponding static response. On the other hand, maximum dynamic and static forces in diagonal L2U1, also at the upper end, were 99.27 and 89.48 kips, respectively, corresponding to 33-ton bogie-wheelset load applied at floor beam L3L3 on the bridge. The resulting impact percentage was only 10.95.

For a structure like the Big Creek Bridge, stress reversal is a remote possibility, and can occur only in those members in which static stresses are quite low to start with. In all of the TLV impact tests, such a reversal occurred only for stresses at the lower cross-section of hanger L1U1 of north truss. The corresponding loading condition consisted of applying 39-kip mean bogie wheel load at a position mid-way between panel points L1 and L2 on east side of the bridge. The resulting maximum dynamic and static axial forces were -1.95 and 6.82 kips respectively, and gave an impact percentage of 128.6. This stress reversal impact percentage is shown in Exhibit 25.

Exhibit 26 shows maximum impact percentages for various members of north truss. As seen in this exhibit, least impact percentage occurred in end post and the most in diagonal. The maximum impact percentages were however lower than 35 in all members. The design impact percentages in hanger L1U1 recommended by the AREA, would be about 45.3 for 33-ton axle load and 46.5 for 39-ton axle load. Similarly, the AREA impact percentages for

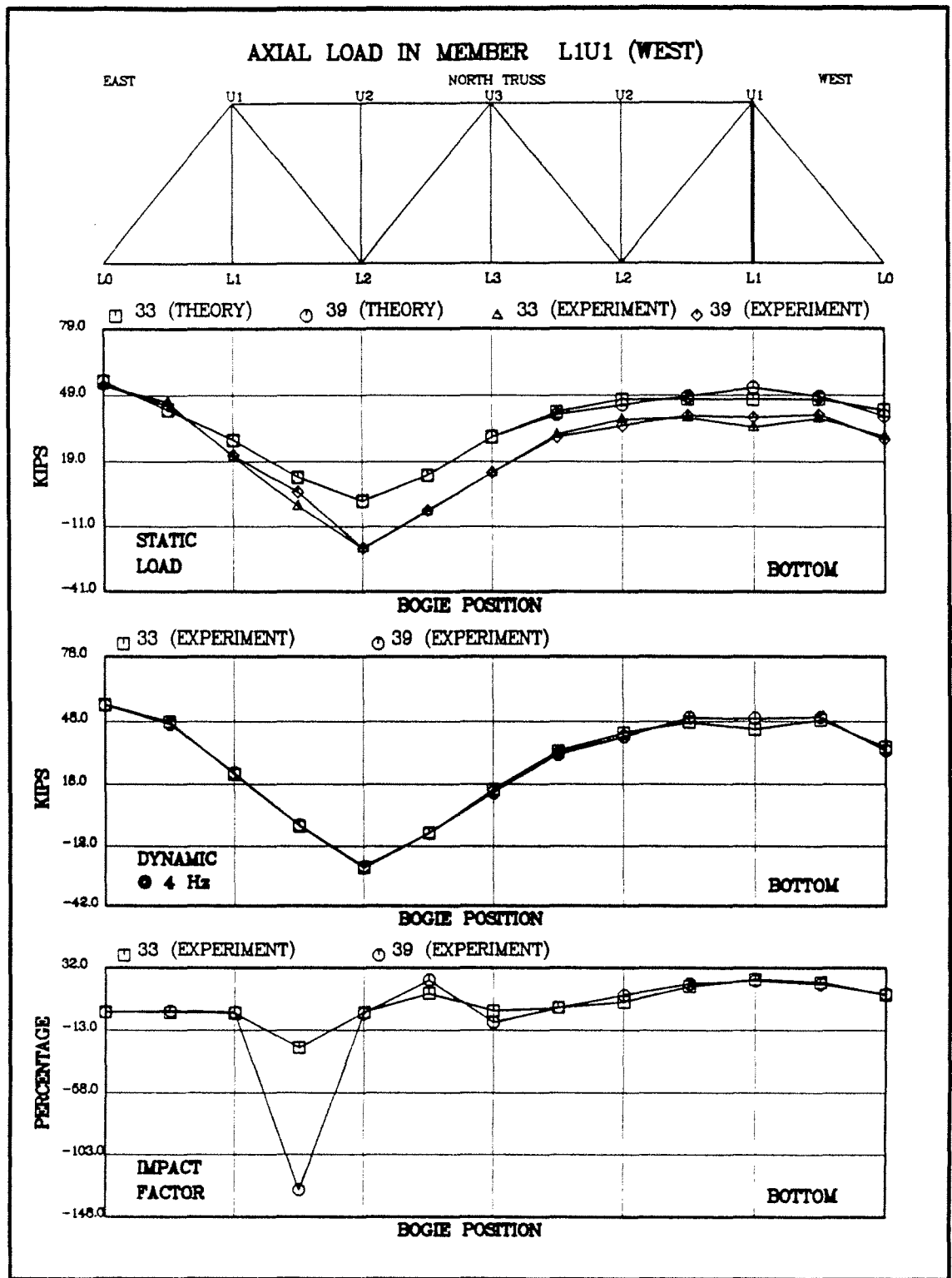

Exhibit 25. Variation of Impact Percentages and Maximum Axial Forces in West Hanger L1U1 (Lower End) of North Truss due to the TLV Consist at Various Locations on the Bridge.

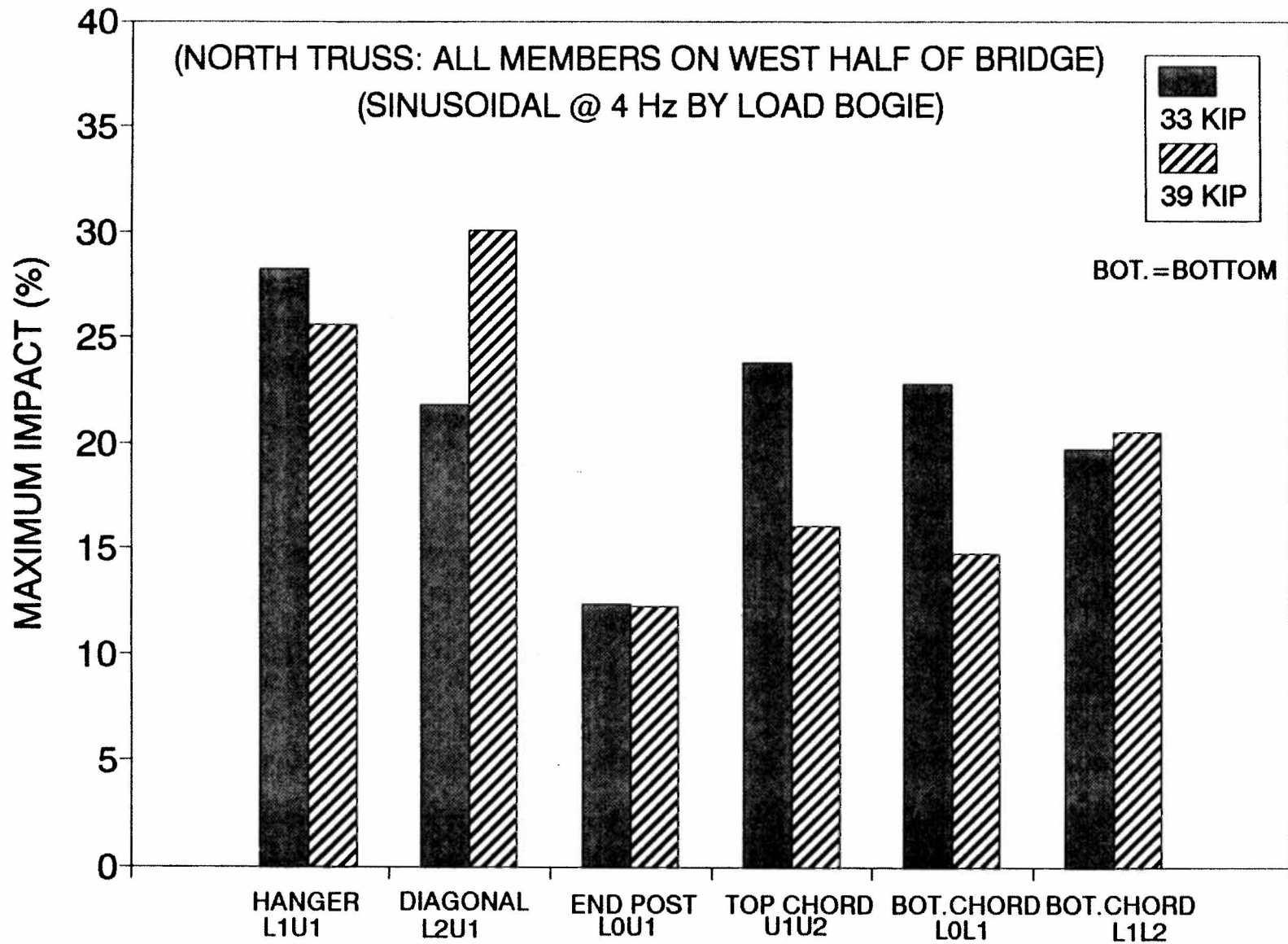

Exhibit 26. Maximum Impact Percentages in Various West side Members of North Truss from the Results in the TLV Impact Tests.

diagonal L2U1 would be about 27.3 for 33-ton axle load and 28.5 for 39-ton axle load. A comparison between the AREA impact percentages and maximum experimental impact percentages in Exhibit 26 shows a good agreement for diagonal, while the AREA percentages for hanger are almost 100% higher. The higher AREA impact percentages in bridge members reflect a rather prudent conservatism in the design of members which may experience bending.

It can be concluded that impact percentage in a bridge member is load position specific, and may require a similar treatment as that of static axial force in terms of influence line. Also, it should again be pointed out that larger differences in impact percentages occur only when static member forces are small to start with. A knowledge of variation of impact percentages, similar to those given in Exhibits 23 and 24, are therefore, deemed essential for the analysis of member forces in a bridge.

Some limitations of the TLV impact tests can be stated in the following: a) the TLV consist does not represent a real train loading on the bridge; b) the effect of AAR-100 instrumentation car and locomotive can not be subtracted, in attempting to isolate the TLV effect, due to vibrations of the bridge; c) the sinusoidal excitation by the TLV bogie-wheelset at 4 Hz may not be sufficient to induce comparable bridge vibrations due to a real train loading; and d) impact percentages shown in the exhibits may be high because of lower static stresses due to lighter weight of the TLV consist.

In spite of the above mentioned limitations, the impact tests using the TLV provided a means to assess the relative magnitudes of

impact percentages in various members of the Big Creek Bridge.

5.2 FORCED VIBRATION TEST RESULTS

The resonant frequencies were obtained by identifying the frequencies at which a member experienced its relative maximum response amplitudes. A relationship of member structural response with respect to steady-state load frequencies, known as the resonance curve, was used for this purpose.

In reading the forced vibration test results, it however, should be noted that the TLV mass and also mass of that portion of the AAR-100 instrumentation car which was on bridge did couple with bridge vibrations. Due to added masses, the resulting bridge frequencies might be lower than the bridge natural frequencies. On the other hand, member resonant (characteristic) vibrations will not be affected by added mass to the bridge, except the fact that resulting resonant vibrations may have greater amplitudes. This happens because the member vibrations depend only on its material and sectional properties, and its end connections. Also, as long as bridge has been excited at a certain mode, the steady-state member vibrations will occur with respect to that mode only. The independence of member resonant vibrations provides a rather very useful criterion in quantifying vibrational characteristics of the bridge structure due to a realistic forced vibration test using the TLV.

5.2.1 Resonance Test Results

The resonance curve for axial force measured in hanger L1U1 of north truss is shown in Exhibit 27. Similar curves for various other members of north truss are given in Appendix D. In Exhibit 27, dominant response peaks at frequencies of 3, 7 and 13 Hz correspond to the 1st, 2nd and 3rd natural mode, respectively. Similar dominant peaks at 3, 7 and 13 Hz were also evident for other members of the bridge (Appendix D). Based on concurrent member dominant responses at these frequencies, it was concluded that 3, 7 and 13 Hz were also bridge resonant frequencies corresponding to the first, second and third bending mode, respectively.

Assuming a linear response, any change in length of a bridge member is directly proportional to the axial force in that member. As such, member damping at resonance, was computed using information from the axial force resonance curve of that member. Furthermore, it was assumed that although these calculations pertained to the particular response of a member in the bridge, an overall damping in bridge could be attained from these values.

An estimation of member modal damping was made by determining its response magnification factor at a corresponding resonant frequency. The dynamic magnification factor was determined as the ratio of maximum or resonant response to the corresponding static response. The damping ratio was then found as one-half of the inverse of the dynamic magnification factor [9].

The percentages of critical damping computed using the dynamic

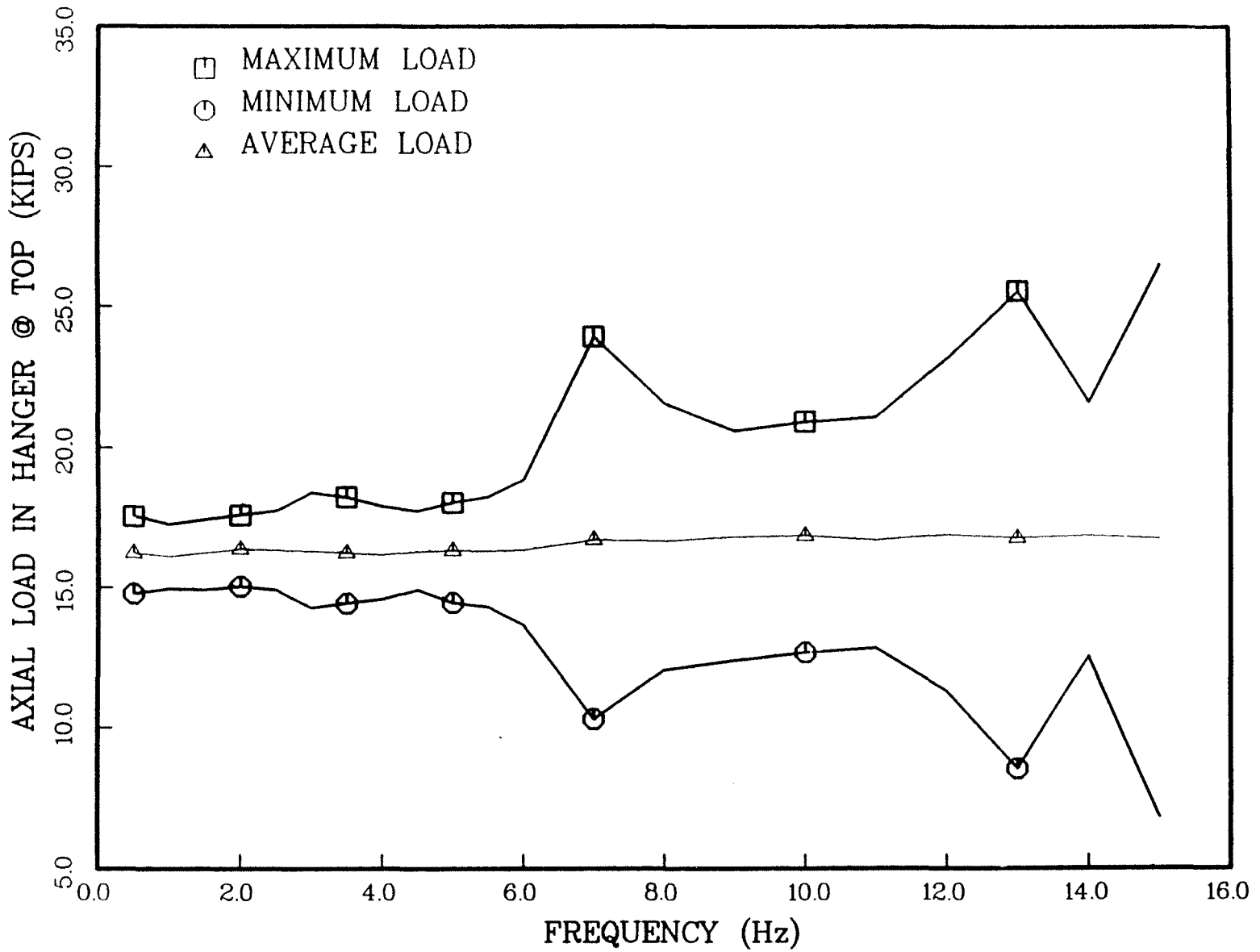

Exhibit 27. Resonance Curve of the Axial Force in West Hanger L1U1 of North Truss from the Results of the TLV Steady-State Sinusoidal Tests on the Bridge.

magnification at resonant frequencies for various bridge members, are given in Exhibit 28. For axial resonant response of hanger, the damping ratios were computed to be 6.49, 2.08 and 1.72, respectively, at 3, 7 and 13 Hz. As can be seen, these damping ratios decrease as the resonant frequency increases. A study of strain histories and also the resonance curve in Exhibit 27 shows that hanger strain amplitudes progressively increase at higher resonant frequencies. This inverse relationship thus explains the decreasing damping percentages at higher modes in the hanger. Such a systematic decrease of damping ratio, at higher modes, for other members of the bridge was not apparent. From a close examination of vibration amplitudes it was found that extent of a member vibration magnification, and thereby the damping ratio, depended on that member's position in the overall structure of the bridge.

5.2.2 Sweep Test Results

It is required in a sweep test that power supplied by the excitation source be maintained at a constant level during the sweep. It was unfortunate that spectral power of the TLV exciter actuators varied in these tests. As an example, Exhibit 29 shows the power spectrum of the bogie-wheelset actuator load at left wheel for the 0-5 Hz sweep test. As can clearly be seen in this exhibit, the actuator power was not constant in the test. A depression in spectra occurred at about 3 Hz, and the actuator power rose towards end of the sweep. As such, data from these tests could not be used.

BRIDGE COMPONENT				MODE NUMBER		
				1	2	3
				FREQUENCY, Hz		
				3	7	13
MEMBER	SYMBOL	SIDE	GAGE LOCATION	DAMPING RATIO		
HANGER	L1U1	WEST	TOP	6.49	2.08	1.72
HANGER	L1U1	WEST	BOTTOM	6.24	2.27	1.69
DIAGONAL	L2U1	WEST	TOP	1.86	1.14	8.30
DIAGONAL	L2U1	WEST	BOTTOM	1.65	1.02	4.55
END POST	L0U1	WEST	TOP	0.07	0.03	0.10
BOTTOM CHORD	L0L1	WEST	LEFT	0.07	0.04	0.07
BOTTOM CHORD	L1L2	WEST	RIGHT	0.37	0.18	0.34
TOP CHORD	U1U2	WEST	RIGHT	1.37	0.81	3.64

Exhibit 28. Damping Ratios in Various Members of North Truss from the Results of the TLV Steady-State Sinusoidal Tests on the Bridge.

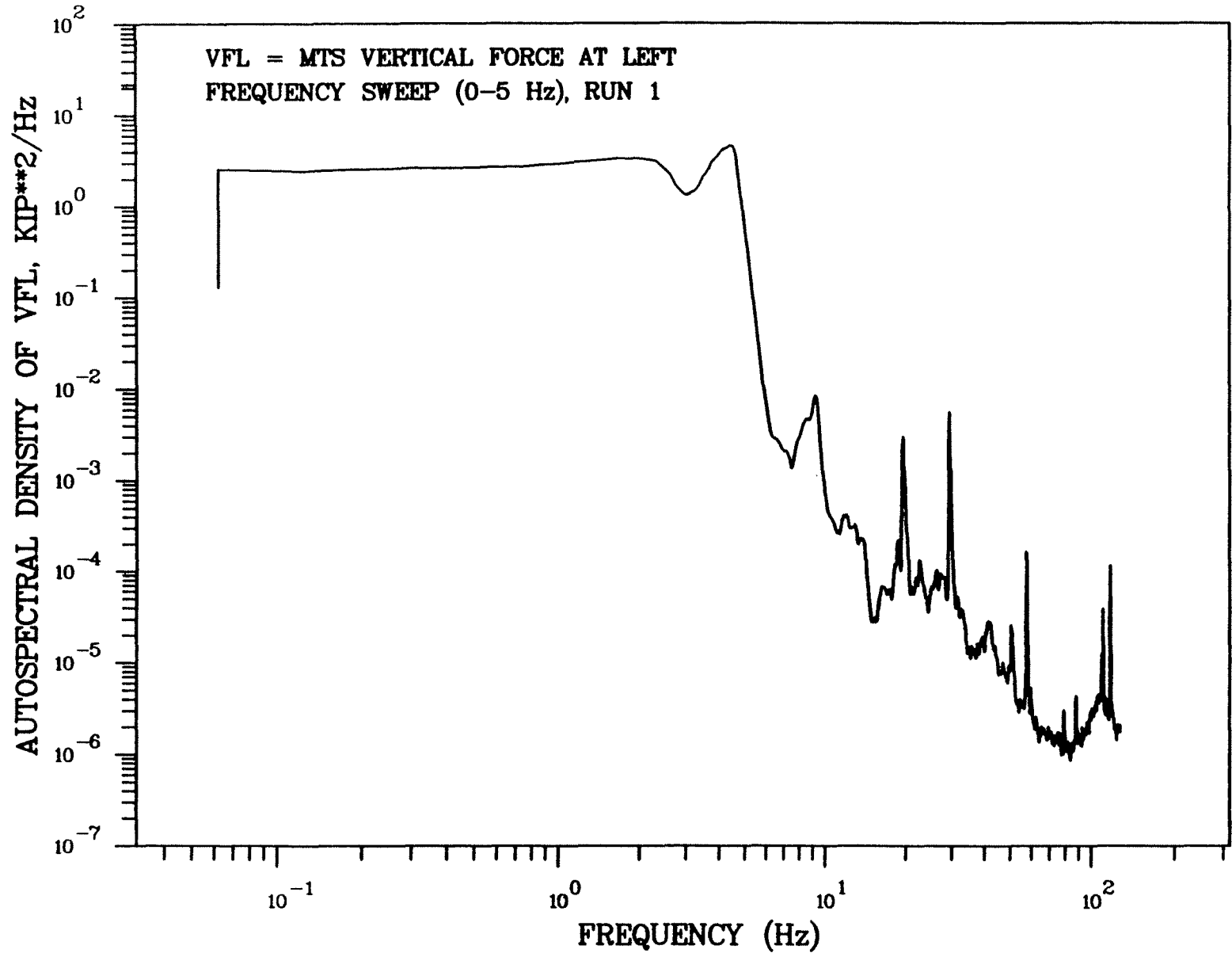

Exhibit 29. Power Spectral Density of the TLV Bogie-Wheelset Actuator Load on the Left Wheel for the 0-5 Hz Sweep Test.

5.3 MOVING TEST RESULTS

The results of moving tests are presented in terms of the strain histories in hanger L1U1 of north truss. The histories of strain measurements at the upper end of hanger L1U1 are given in Exhibits 30 and 31 for bogie-wheelset loads of 33 and 39 tons, respectively, at 10 mph speed. Similarly, these results at 20 mph speed are given in Exhibits 32 and 33. The bounce test results, also in terms of strain of this hanger, are given in Exhibit 34. The channel identifications in these exhibits are same as those given earlier in Exhibit 11 of Section 4.1.1.

As seen in these exhibits, the shape of strain history of each channel is similar, except magnitude of the respective strain. Due to symmetry of the cross-section and symmetrical placement of the channels, difference in the magnitudes of strain increases due to bending of the hanger. The maximum axial strains are 112.14 and 112.15 microstrains, respectively, at 10 and 20 mph for bogie-wheelset load of 33 tons. The corresponding axial force will be about 62.4 kips at both the speeds. The effect of speed on stress was found to be negligible for the maximum positive (tensile) response of hanger in this test. The maximum compressive axial strains in hanger are 20.3 and 22.29 microstrains at 10 and 20 mph, respectively; and give corresponding compressive axial forces of 11.3 and 12.4 kips. A dynamic amplification at 20 mph of about 9.8, with respect to the response at 10 mph, occurred.

The hanger axial responses under 39-ton bogie-wheelset load are: maximum tensile strain 111.5 microstrains (62.05 kips axial

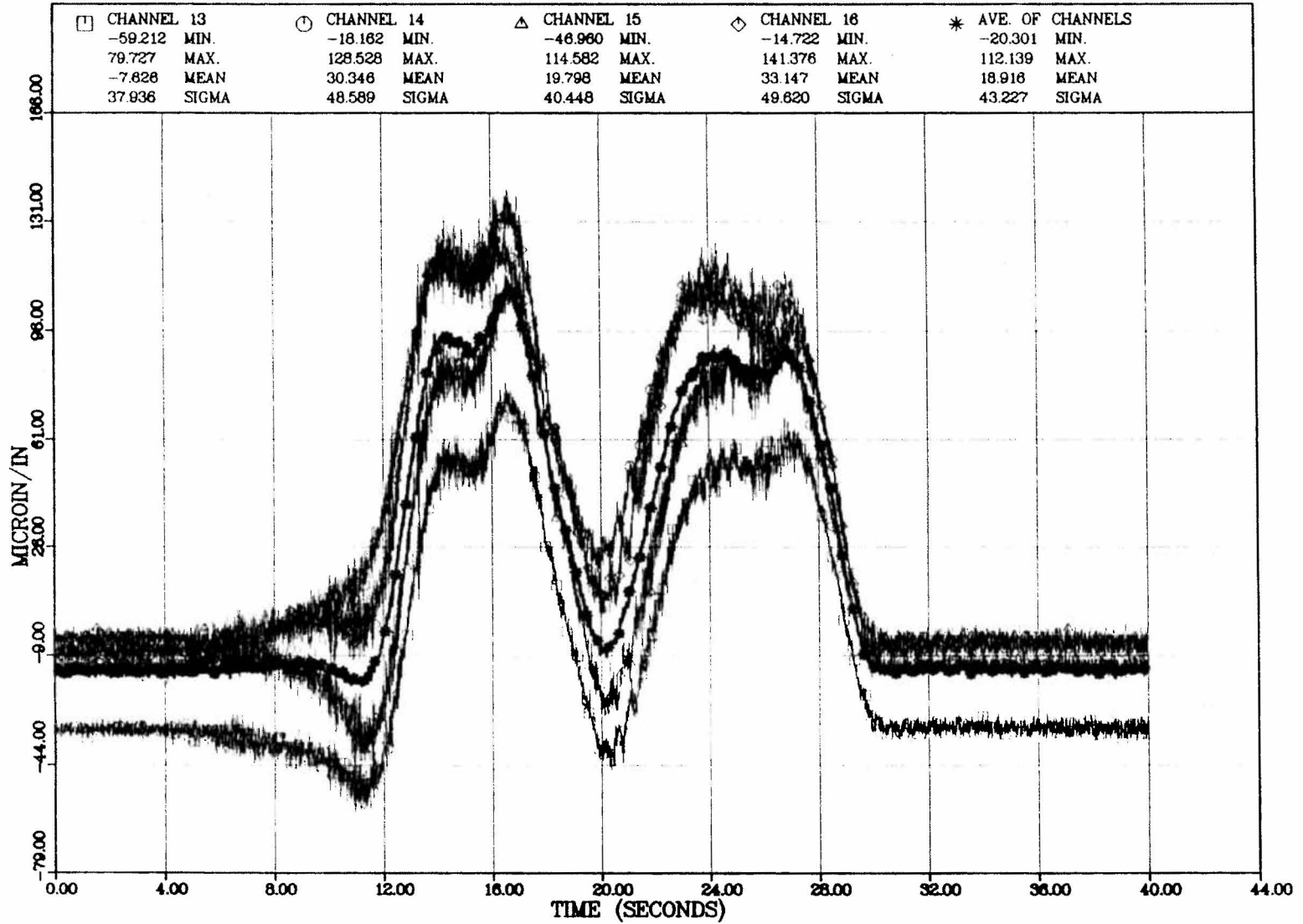

Exhibit 30. Strain Histories in West Hanger L1U1 (Upper End) of North Truss due to the Moving TLV Test Consist at 10 mph with Bogie-Wheelset Constant Load of 33 Tons.

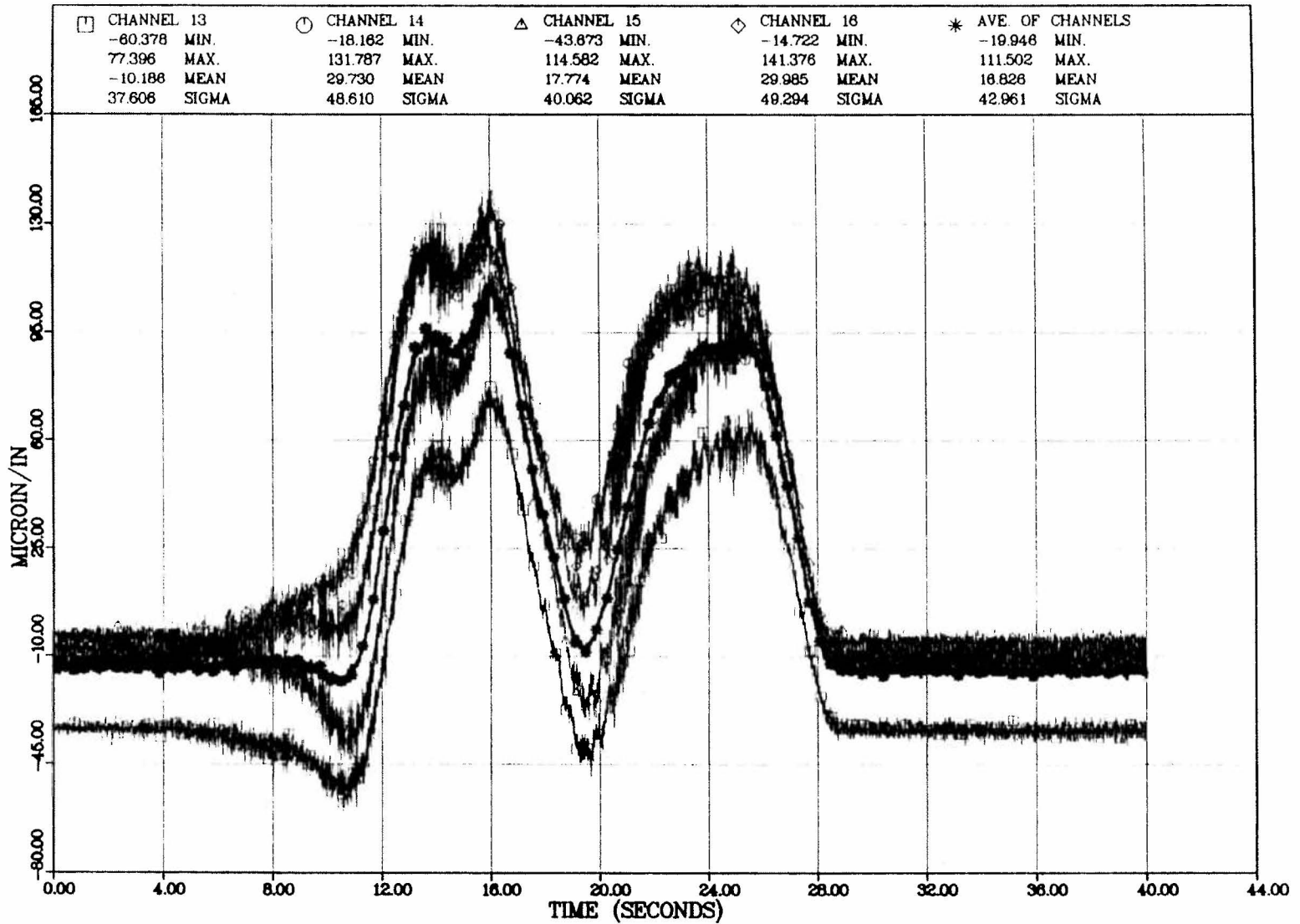

Exhibit 31. Strain Histories in West Hanger L1U1 (Upper End) of North Truss due to the Moving TLV Test Consist at 10 mph with Bogie-Wheelset Constant Load of 39 Tons.

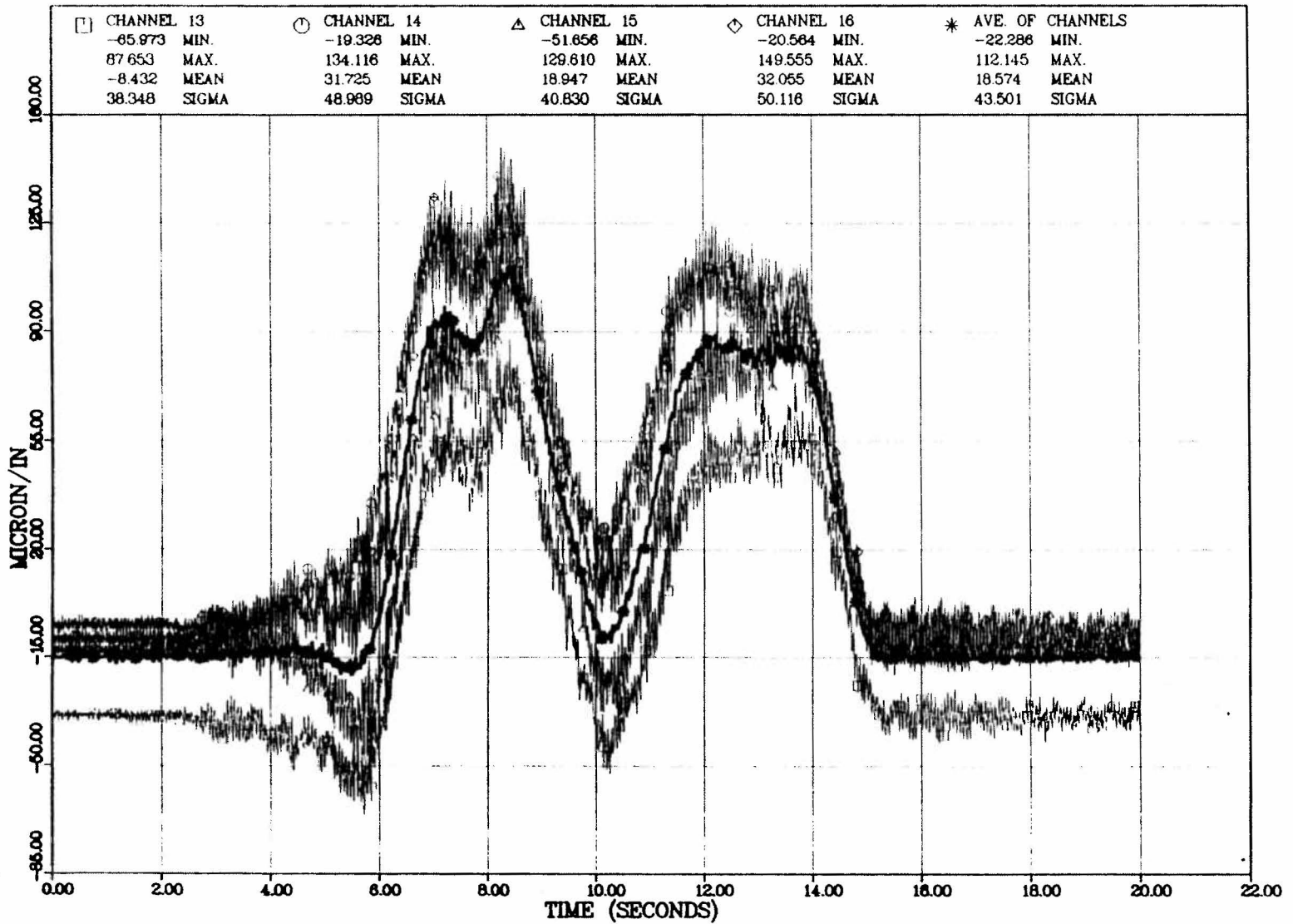

Exhibit 32. Strain Histories in West Hanger L1U1 (Upper End) of North Truss due to the Moving TLV Test Consist at 20 mph with Bogie-Wheelset Constant Load of 33 Tons.

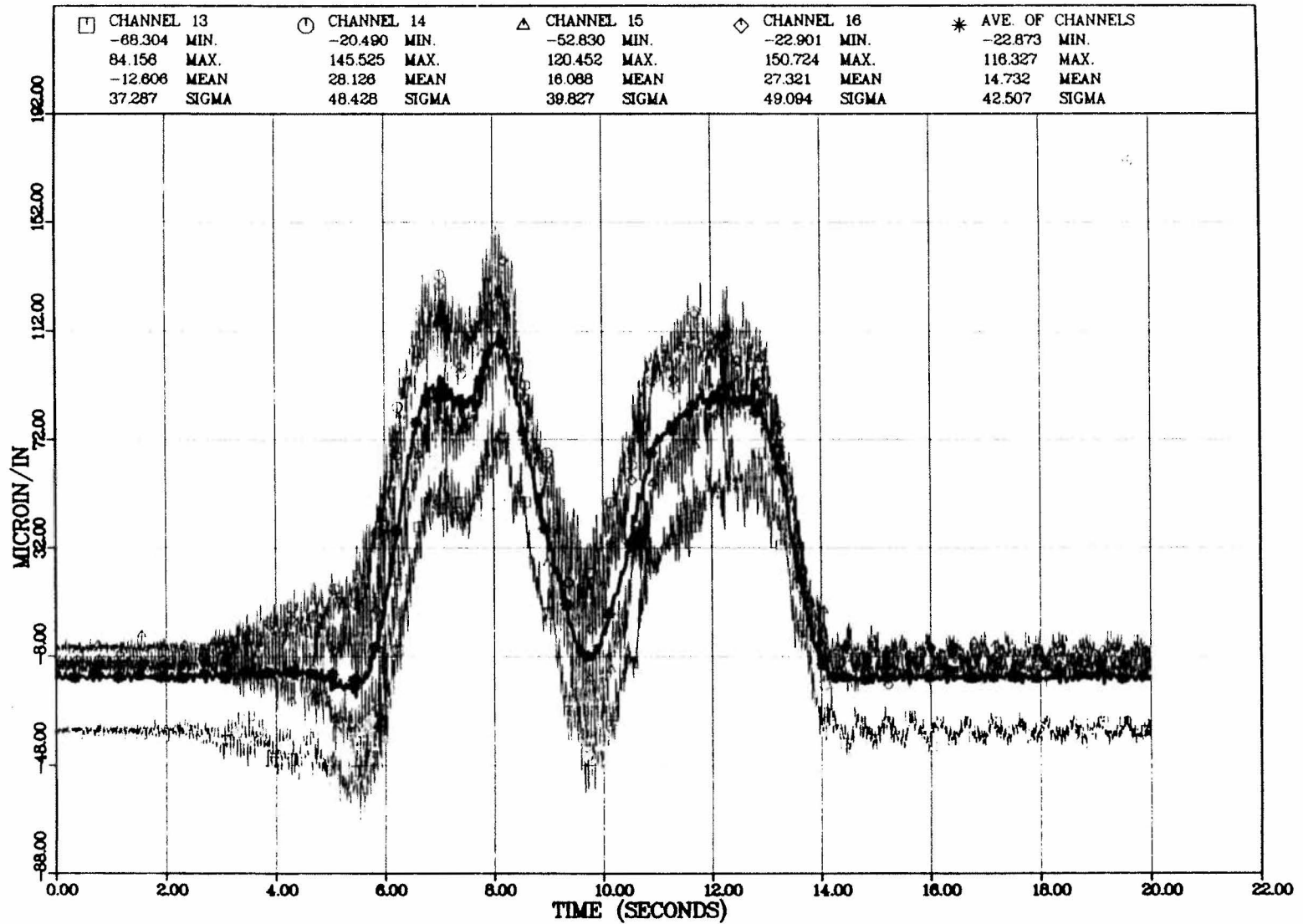

Exhibit 33. Strain Histories in West Hanger L1U1 (Upper End) of North Truss due to the Moving TLV Test Consist at 20 mph with Bogie-Wheelset Constant Load of 39 Tons.

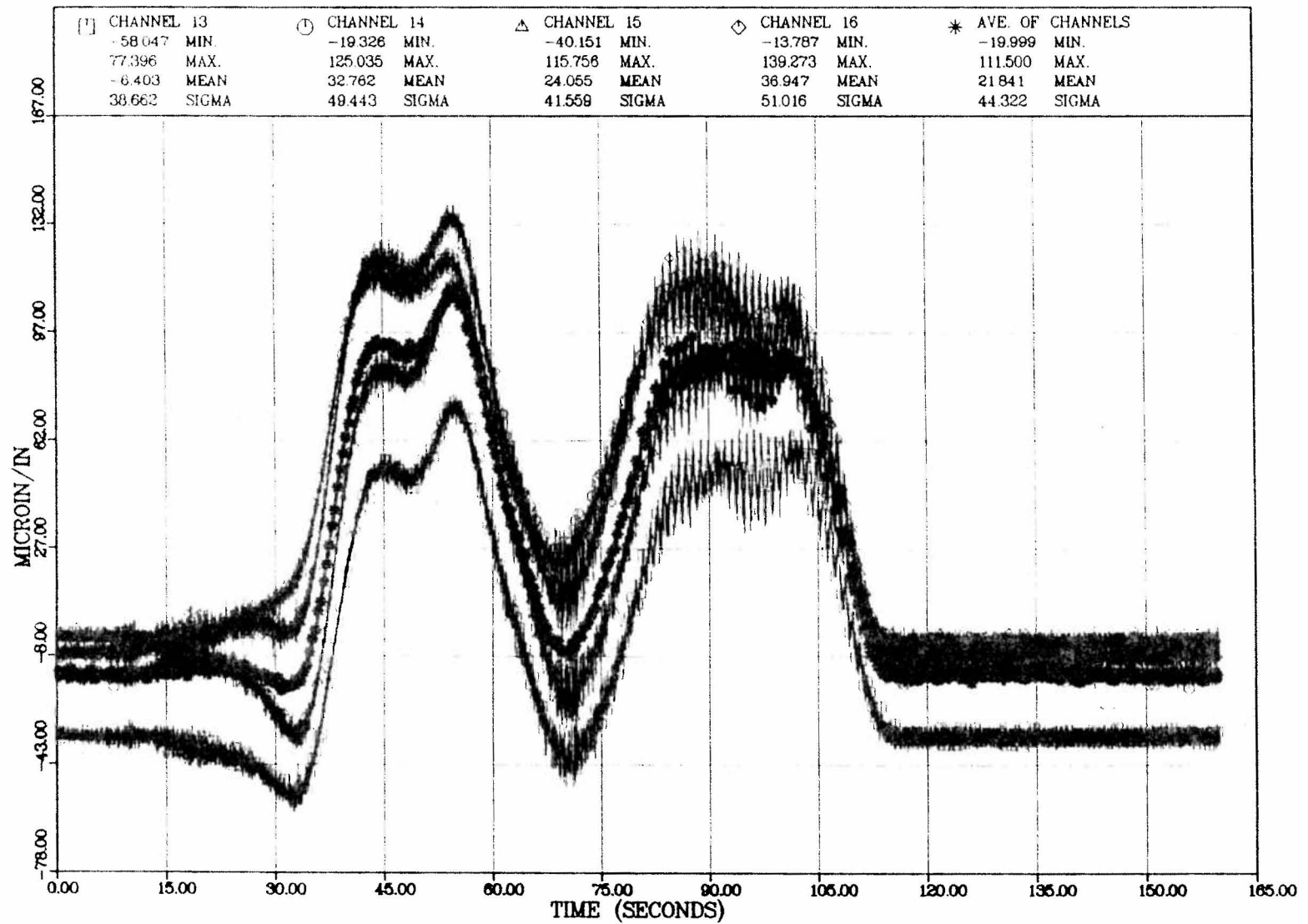

Exhibit 34. Strain Histories in West Hanger L1U1 (Upper End) of North Truss due to the Moving TLV Test Consist at 2 mph with Bogie-Wheelset Sinusoidal Load of 33+/-7 Tons at 1 Hz.

force) at 10 mph, 116.33 microstrains (64.74 kips axial force) at 20 mph, and a dynamic amplification of 4.3. The corresponding maximum compressive strains are 19.95 at 10 mph and 22.87 at 20 mph giving a dynamic amplification of about 14.6. The maximum tensile strain in bounce test was 111.5 microstrains (62.05 kips axial force), and maximum compressive strain was 20 microstrains (11.13 kips axial force). The bounce test results were found to be similar to the moving test results at 10 mph for 33-ton bogie-wheelset load.

(This page left blank)

6.0 SUMMARY AND CONCLUSIONS

In June 1991, the TLV was used to conduct a series of tests on the Big Creek Through Truss Bridge on the Norfolk Southern Railroad in Tennessee. This was the first time that the TLV was used for a bridge test. The primary objective of these tests was to determine the usefulness of the TLV as a tool in bridge testing. Based on axial force results presented in this report, the following observations and conclusions were made:

1. The results indicated that tests, conducted under controlled static and dynamic loads using the TLV, can be used in the study of stresses in railroad bridges.
2. Limitations, however, were imposed on testing due to the TLV truck centers (47 feet) being shorter than span length (about 156 feet) of the bridge. As a result, the bridge structure was subjected to additional loads both from the TLV trucks and other vehicles of the test consist resting on the bridge.
3. In the Stationary tests, bridge responses with and without the external bogie load were measured to isolate the bogie load from other test consist loads on the bridge. The subtraction of no-bogie-load results from corresponding bogie-load results was found to eliminate the effect of loading by the AAR-100 instrumentation car and the locomotive on the bridge. This subtraction, however, did not eliminate the TLV truck-load effect. In fact, a residual effect due to unloading on the TLV trucks (about 8 kips per wheel under 33 ton bogie-wheelset load) remained.
4. The TLV static influence lines of various bridge members were

determined by using the isolated bogie-wheelset load and the accompanying TLV truck unloadings. It was postulated that such influence lines, with appropriate augmentation for dynamic effect of speed, could be used to synthesize stress-time histories in members due to any moving load on the bridge. A determination of force distribution among various bridge members could thus be made.

5. The results suggested that significant differences could exist between the theoretically calculated stresses and those measured during the test. It was believed that this discrepancy was due largely to the partial fixity of the truss connections. The partial fixity of connections, unlike the assumption of free rotation in theoretical analysis of a truss, could cause a redistribution of the applied loads through the bridge structure.

6. It is also believed that the difference between the test and theoretical stresses could occur due to the specific location of strain gages on the member. It is suggested that strain gages should be placed near the center of the bottom chord panel length for axial force measurement.

7. The TLV impact tests were conducted to simulate the dynamic conditions due to passing axles of heavy freight cars at different locations on the bridge. The impact percentage, computed as the difference between maximum dynamic axial response and the respective maximum static axial response, was found to be the least in end posts and the most in the diagonals. The maximum impact percentages, in general, were lower than 35.

8. It was found that a large impact percentage occurred only when

the static axial response of the member was small to begin with. Also, the occurrence of the maximum impact percentage did not coincide with the maximum response of the member to applied loads.

9. Some of the limitations of the TLV impact tests could be stated as follows: a) hangers created a frame with the floor beam such that axial stress and the bending stress occurred simultaneously, mainly in the vicinity of the floor beam knee braces, b) some bending also occurred in all bridge members due to the fixity in the member connections, c) the TLV consist did not represent a real train loading on the bridge, d) the effect of the TLV trucks, AAR-100 instrumentation car, and locomotive could not be eliminated in dynamic tests, and e) impact percentages might be high due to lower static stresses resulting from the lesser weight of the TLV consist.

10. Despite the limitations mentioned above, it is believed that the TLV provided a viable means to determine relative dynamic amplifications in various members due to impact loading.

11. The vibrational characteristics of the bridge structure were determined by conducting frequency sweep and resonance tests using the TLV. It was determined from a study of power spectra of the TLV actuator loads that the power supplied by the bogie-wheelset to the bridge did not stay constant during frequency sweep tests. The calculation of the bridge resonance frequencies from an analysis of the frequency sweep test data was, therefore, not pursued any further.

12. The dynamic tests showed that bridge member resonances

occurred at frequencies of 3, 7 and 13 Hz corresponding to the 1st, 2nd and 3rd natural (extensional) modes, respectively. It was, therefore, believed that these frequencies were also the bridge's natural frequencies corresponding to the 1st, 2nd and 3rd vertical bending modes, respectively. It is estimated that these frequencies are somewhat lower than normal mode frequencies of the bridge due to the added mass of the TLV consist on the bridge.

13. The dynamic behavior of a bridge member depends on its geometrical and material properties, and its local end conditions. The added mass of the TLV consist on the bridge should, therefore, not affect the bridge member characteristic vibrations. It is thus assumed that the member resonance curves provide a rather indispensable tool in ascertaining the vibrational characteristics of a truss bridge structure using the TLV.

14. As expected for framed or skeletal steel structures [10], bridge member dampings in the first natural (extensional) mode were found to vary from about 0.07 (end post and bottom chord) to 6.49 (hanger) percent of critical damping. At higher modes, the damping percentage for the hanger decreased as the resonant frequency increased. For other bridge members, the damping percentage decreased in the second mode, and then increased in the third mode.

15. The percentage of member modal damping was found to be inversely proportional to the relative amplitude of the member vibration.

16. In general, damping of a member depends on the nature of its material (structural or viscous damping), the extent of looseness

in its connections (frictional damping), its location in the structure, and the frequency mode of its vibration. It was found that the amplitude of the vibration during resonance depended greatly on member location in the bridge structure; and was, therefore, an important factor in governing the amount of member modal damping.

17. The most susceptible member to vehicle dynamics was found to be the hanger. The effect of speed rising from 10 to 20 mph in moving tests was found to be equal to a dynamic amplification of 4.3 for the tensile-force response of the hanger.

The vibration testing using the TLV gives an additional aspect to bridge testing under controlled loads. The resonance tests are seen to have a powerful capability to identify member natural frequencies and modal damping, and thereby those of the bridge. Moreover, a periodic monitoring of natural frequencies and damping of bridge members can be used to detect structural damage. In addition, determination of natural frequencies and mode shapes by tests can be used for a statistical identification of the structure wherein structural design parameters of mass and stiffness are iteratively modified until analysis and test results agree.

(This page left blank)

7.0 REFERENCES

1. Foutch, D.A., "A Summary of Railway Bridge Research Needs," Proceedings, Bridge Research in Progress, Des Moines, IA, September 26-27, 1988, pp. 45-52.
2. Schiff, Scott D., Sprouse, F. Scott, Choros, John, "Loading Spectra and Response for a Railway Bridge on a Heavy-Haul Line," Association of American Railroads, Report No. R-804, Chicago, Illinois, February, 1992.
3. Foutch, Douglas A., Choros, John, Tobias, Daniel H., "Loading Spectra and Response for a Railway Bridge on a Mixed Freight and High Speed Intermodal Line," Association of American Railroads, Report No. R-812, Chicago, Illinois, May, 1992.
4. Foutch, Douglas A., Choros, John, Tobias, Daniel H., "Investigation of a Ballasted Deck Steel Plate Girder Railway Bridge," Association of American Railroads, Report No. R-817, Chicago, Illinois, October, 1992.
5. Kalay, S., et al., "Track Loading Vehicle: Part 1- System Design and Construction," Rail Transportation 1989, ASME Winter Annual Meeting, San Francisco, California, December, 1989.
6. Kalay, S., et al., "Track Loading Vehicle: Part 2- Vehicle Dynamics Modeling," Rail Transportation 1989, ASME Winter Annual Meeting, San Francisco, California, December, 1989.
7. Kalay, S., O'Donnell, W., "Demonstration Testing of the Track Loading Vehicle," Association of American Railroads, Report No. R-782, Chicago, Illinois, February, 1992.
8. Sharma, V., Choros, John, Reinschmidt, A.J., "Static and Dynamic Testing of a Through-Truss Bridge," Association of American Railroads, Report No. R-806, Chicago, Illinois, March, 1992.
9. Paz, Mario, "Structural Dynamics Theory and Computation," 1980 Edition, Van Nostrand Reinhold Company, 135 West 50th Street, New York, NY 10020.
10. Tilly, G.P., "Dynamic Response of Bridges," Transportation Research Record 665, Bridge Engineering, Volume 2, Proceedings of a Conference Conducted by the Transportation Research Board, September 25-27, 1978, National Academy of Sciences, Washington, D.C., 1978.

(This page left blank)

8.0 APPENDICES

8.1 APPENDIX A: Axial Forces in North Truss

A-2

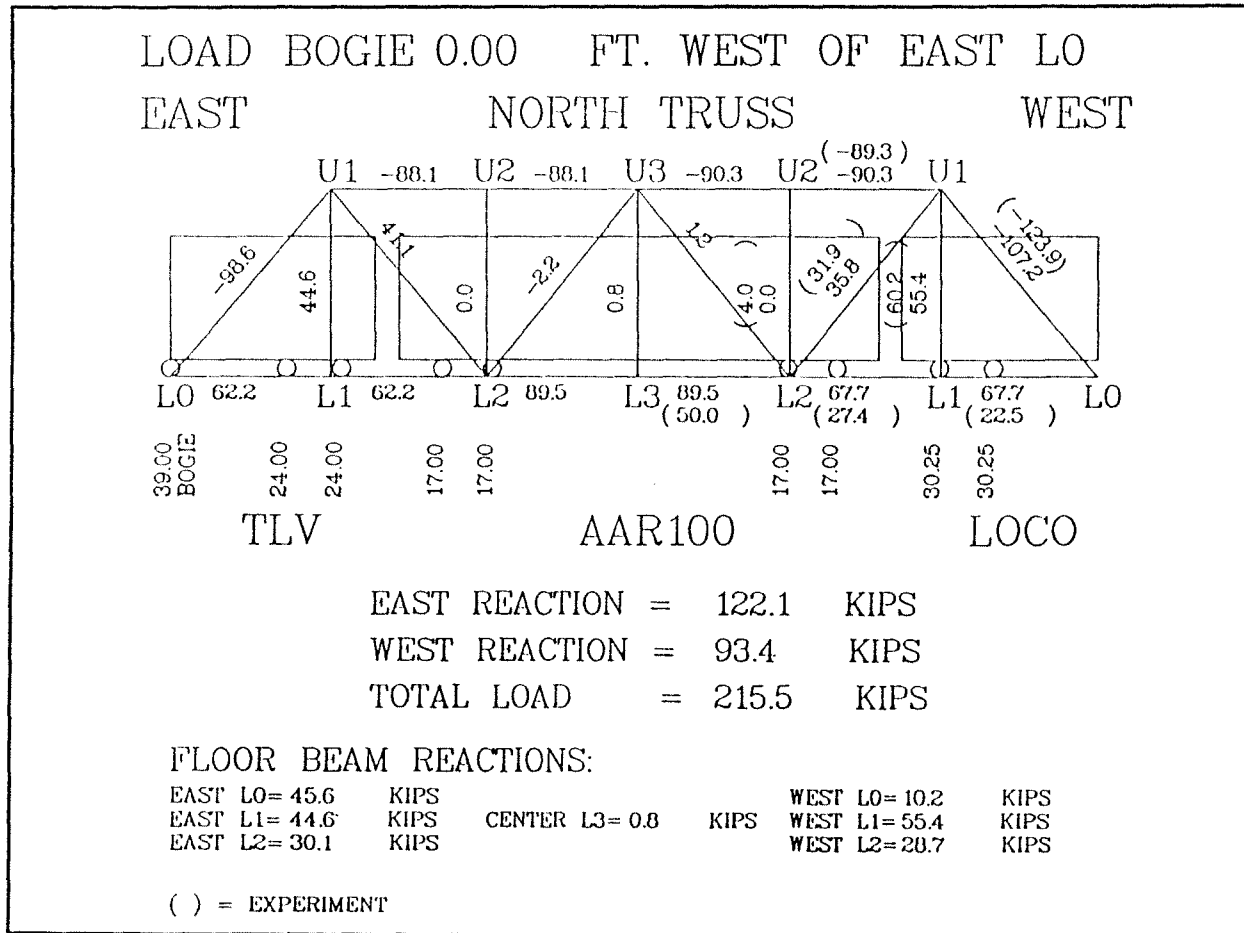

Exhibit A1. Theoretical and Experimental Axial Forces in North Truss Members due to the Stationary TLV Test Consist with Bogie-Wheelset Static Load of 39 Tons Applied on East Floor Beam L0L0.

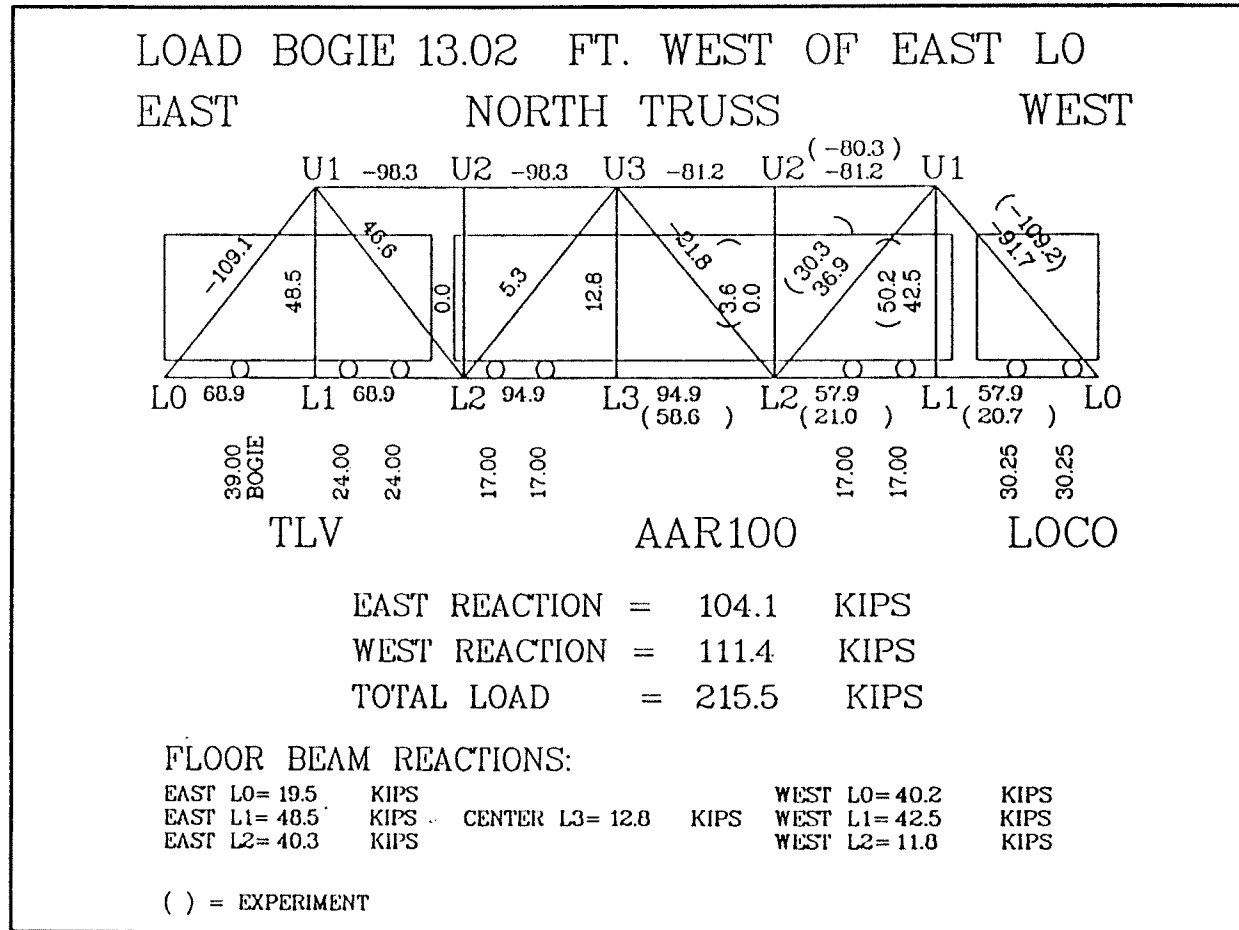

Exhibit A2. Theoretical and Experimental Axial Forces in North Truss Members due to the Stationary TLV Test Consist with Bogie-Wheelset Static Load of 39 Tons Applied on East Bridge Panel L0L1.

A-4

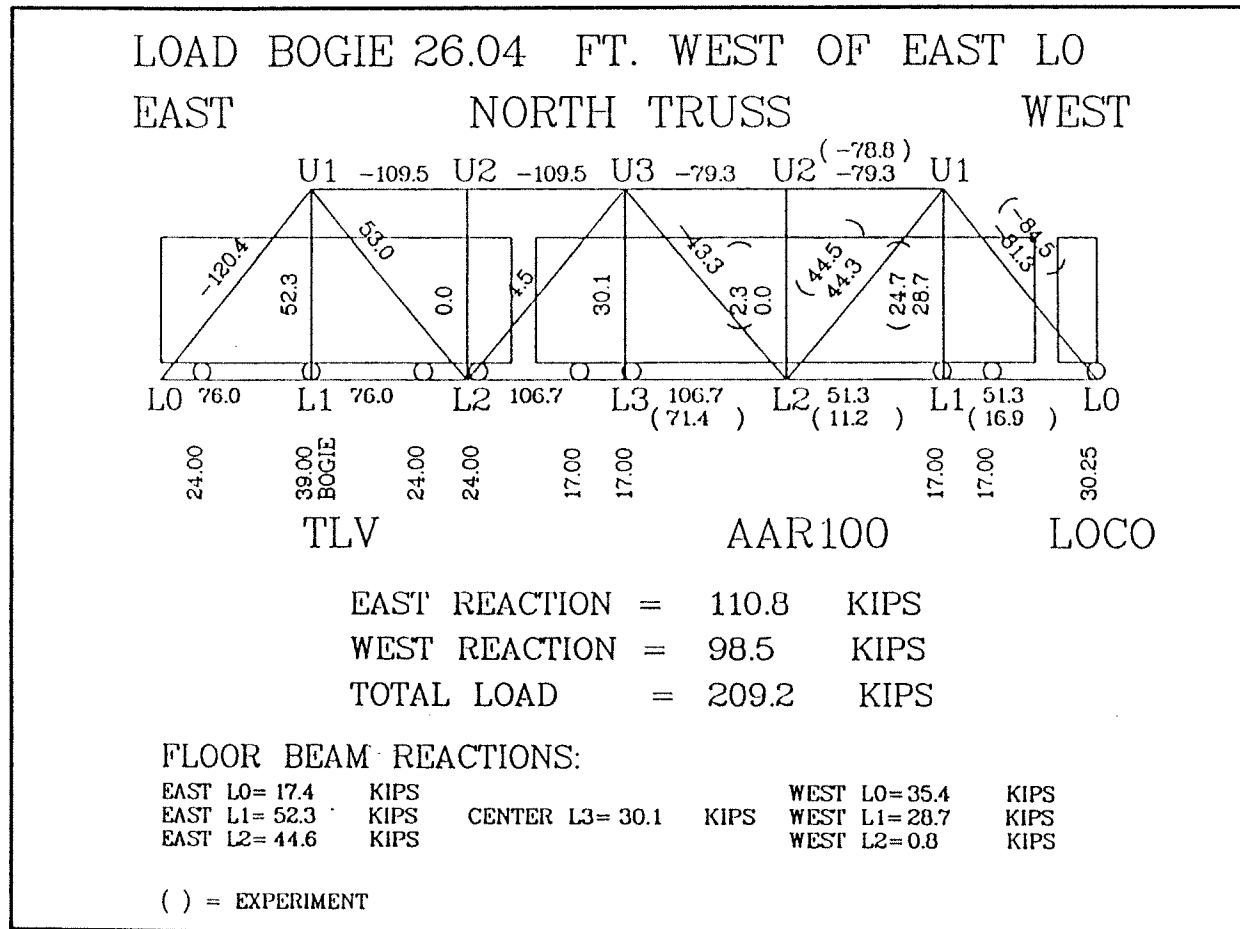

Exhibit A3. Theoretical and Experimental Axial Forces in North Truss Members due to the Stationary TLV Test Consist with Bogie-Wheelset Static Load of 39 Tons Applied on East Floor Beam L1L1.

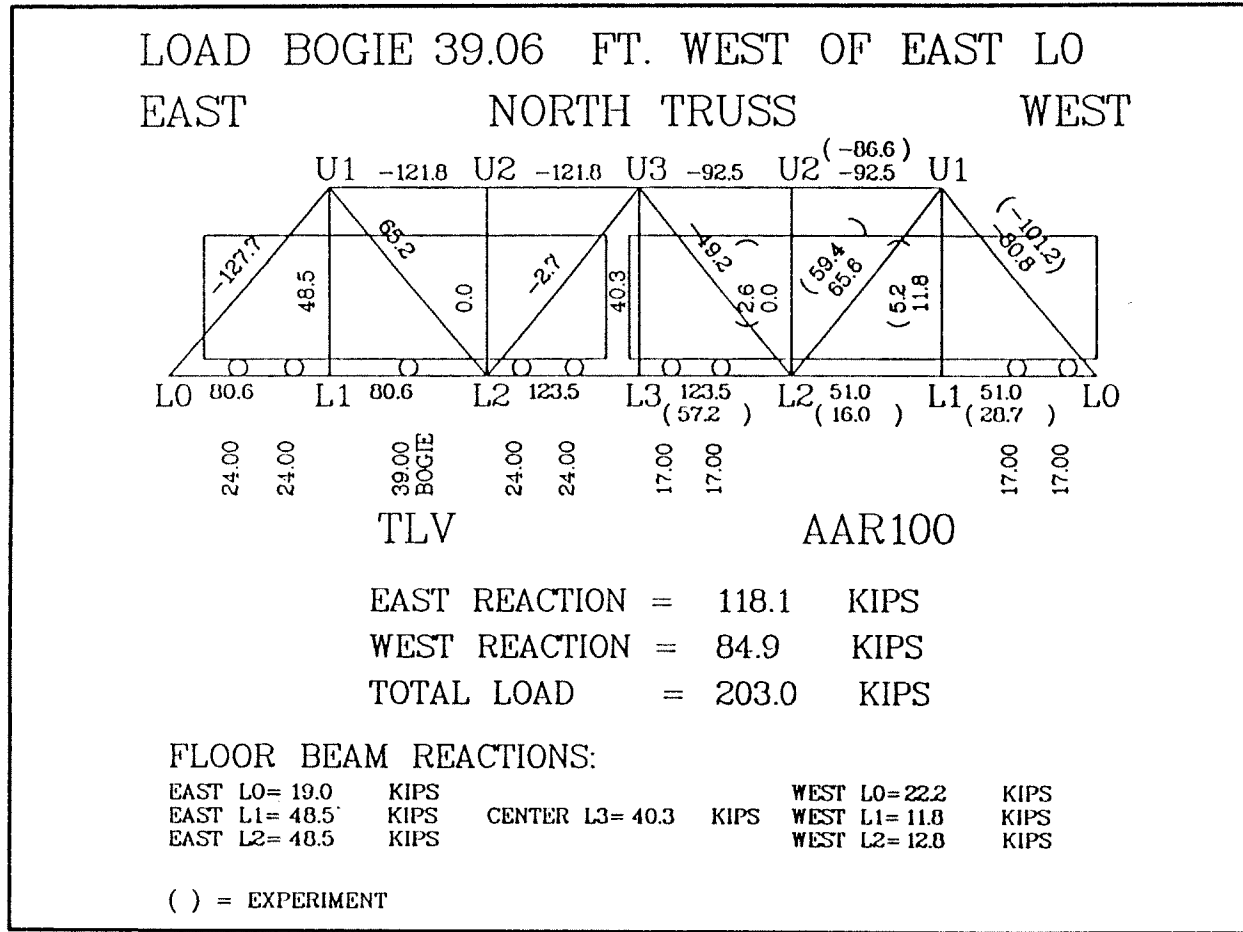

Exhibit A4. Theoretical and Experimental Axial Forces in North Truss Members due to the Stationary TLV Test Consist with Bogie-Wheelset Static Load of 39 Tons Applied on East Bridge Panel L1L2.

A-9

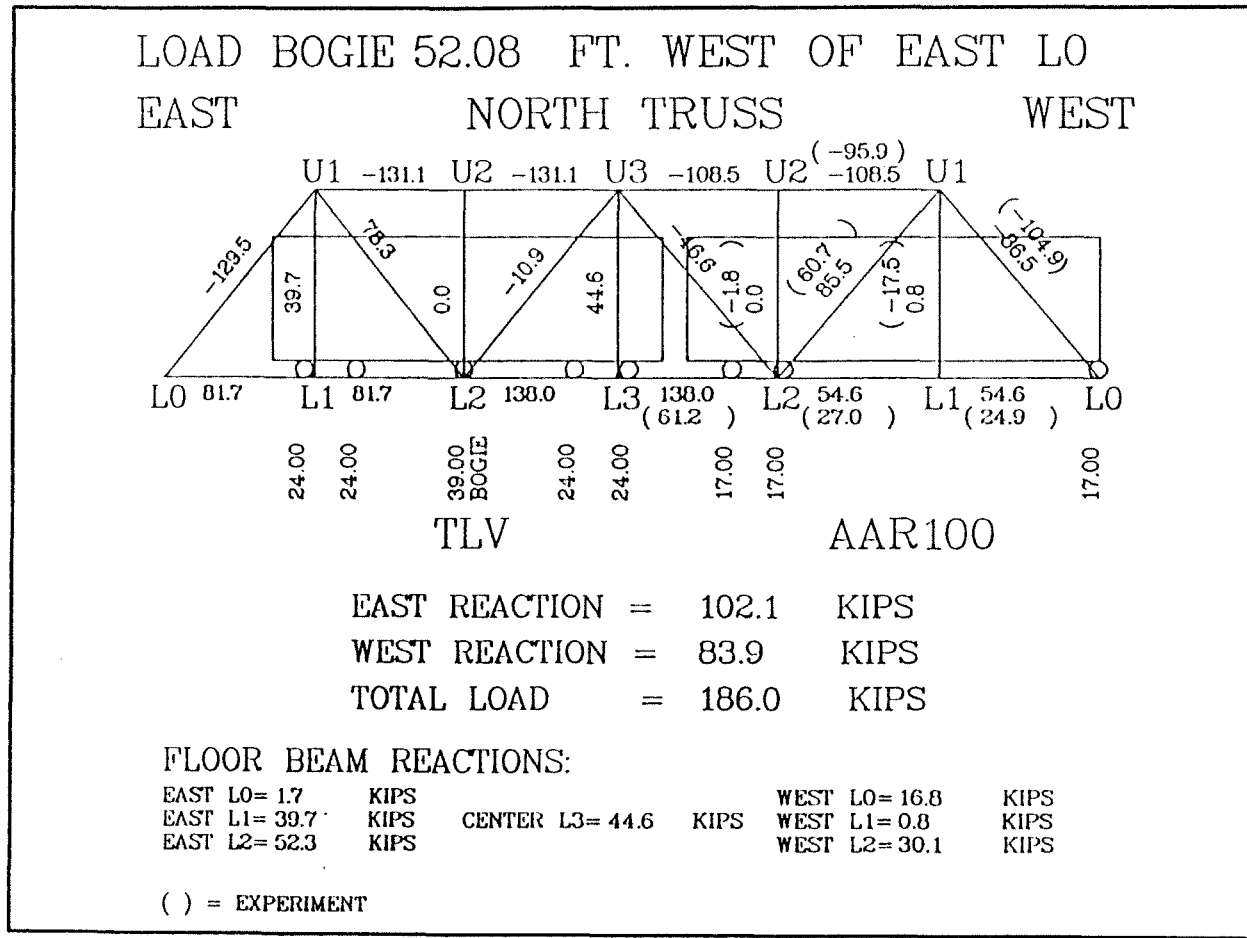

Exhibit A5. Theoretical and Experimental Axial Forces in North Truss Members due to the Stationary TLV Test Consist with Bogie-Wheelset Static Load of 39 Tons Applied on East Floor Beam L2L2.

A-7

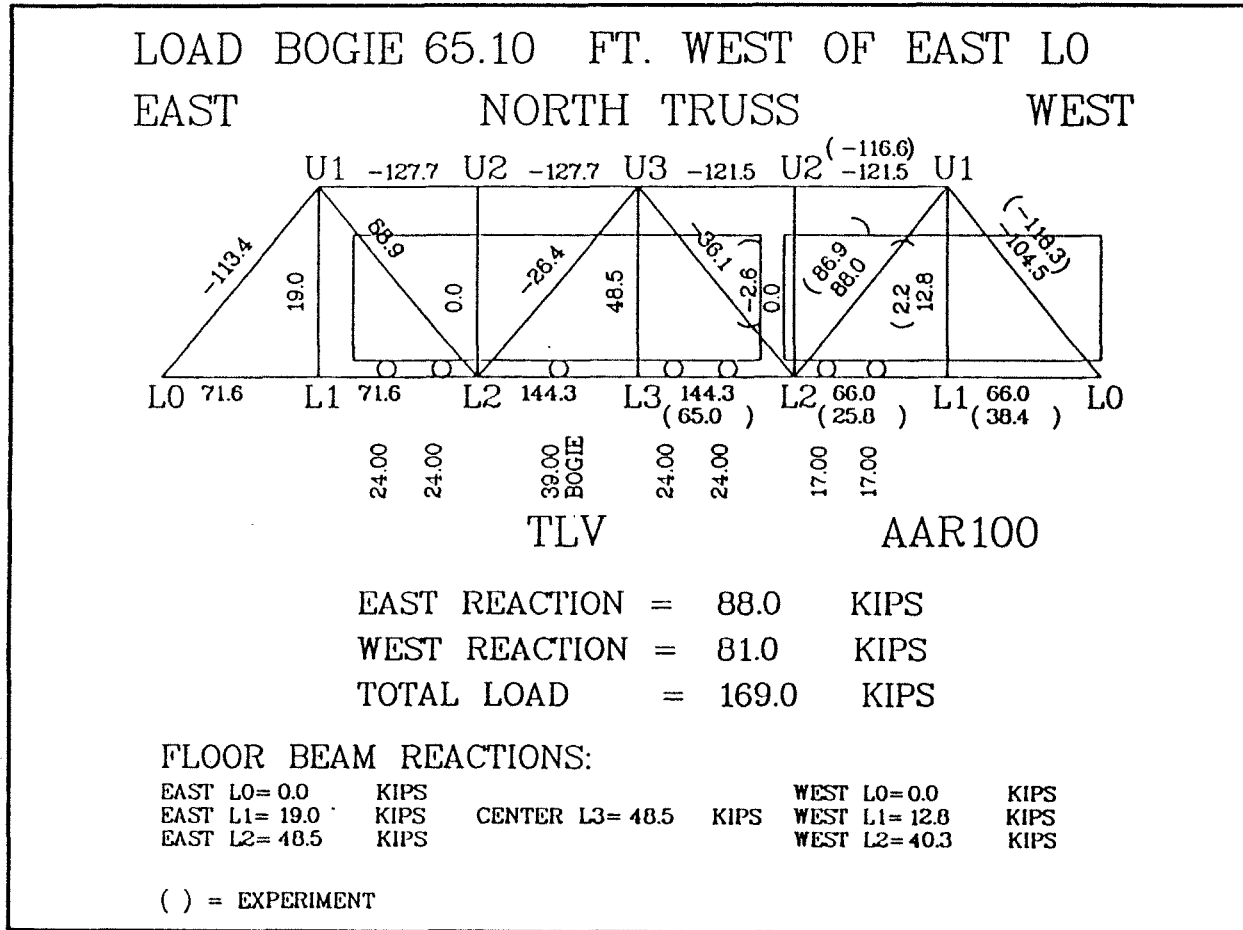

Exhibit A6. Theoretical and Experimental Axial Forces in North Truss Members due to the Stationary TLV Test Consist with Bogie-Wheelset Static Load of 39 Tons Applied on East Bridge Panel L2L3.

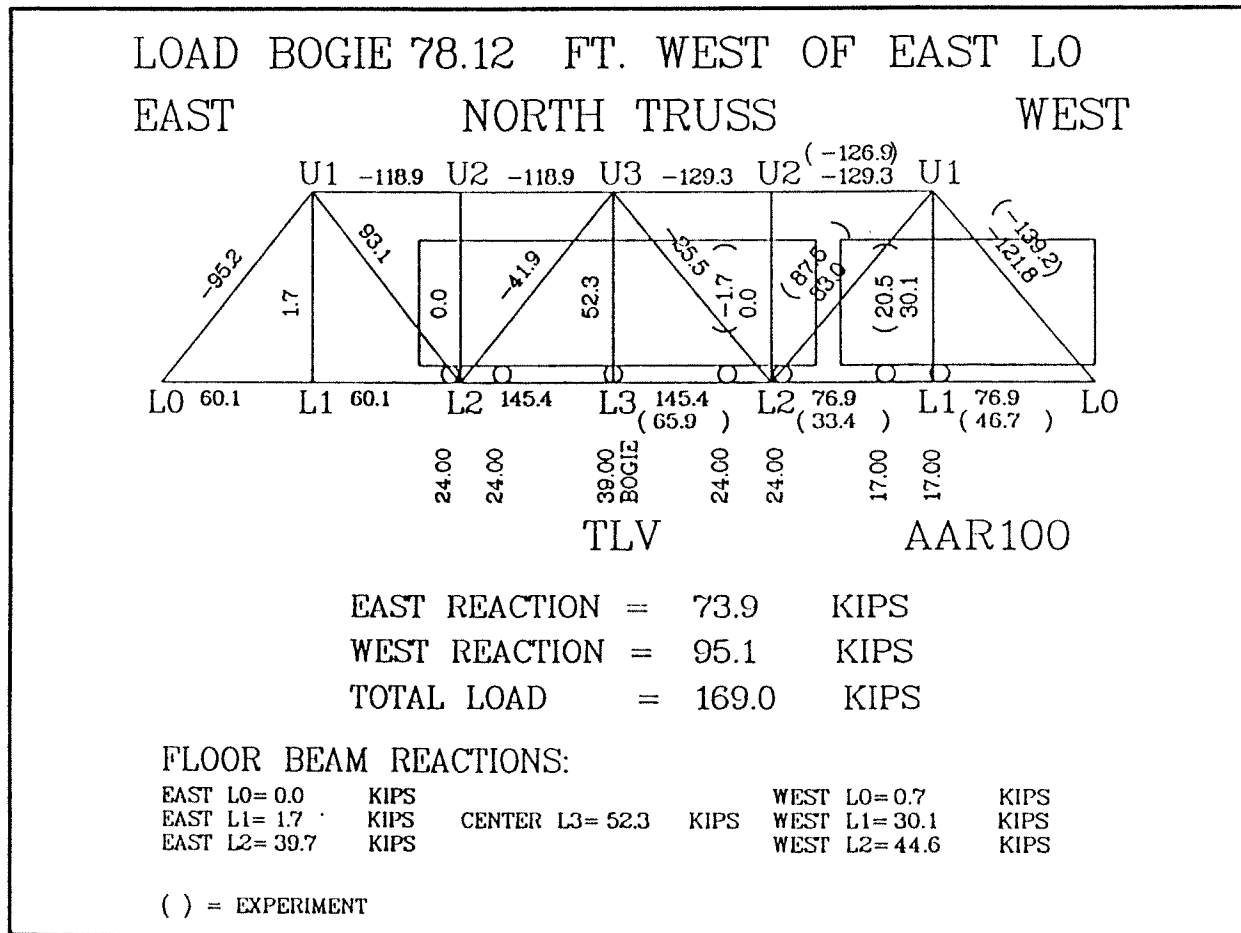

Exhibit A7. Theoretical and Experimental Axial Forces in North Truss Members due to the Stationary TLV Test Consist with Bogie-Wheelset Static Load of 39 Tons Applied on Central Floor Beam L3L3.

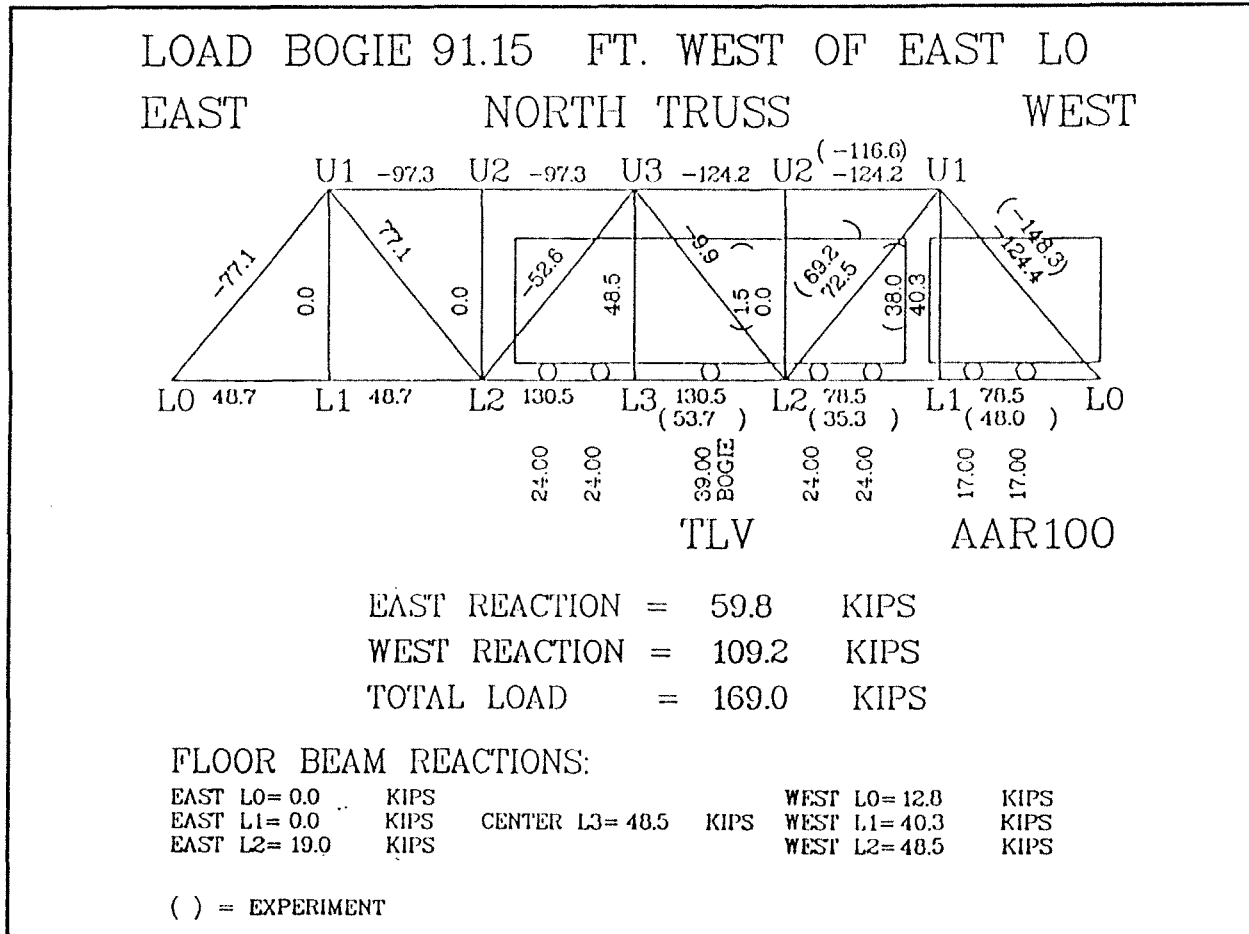

Exhibit A8. Theoretical and Experimental Axial Forces in North Truss Members due to the Stationary TLV Test Consist with Bogie-Wheelset Static Load of 39 Tons Applied on West Bridge Panel L2L3.

A-10

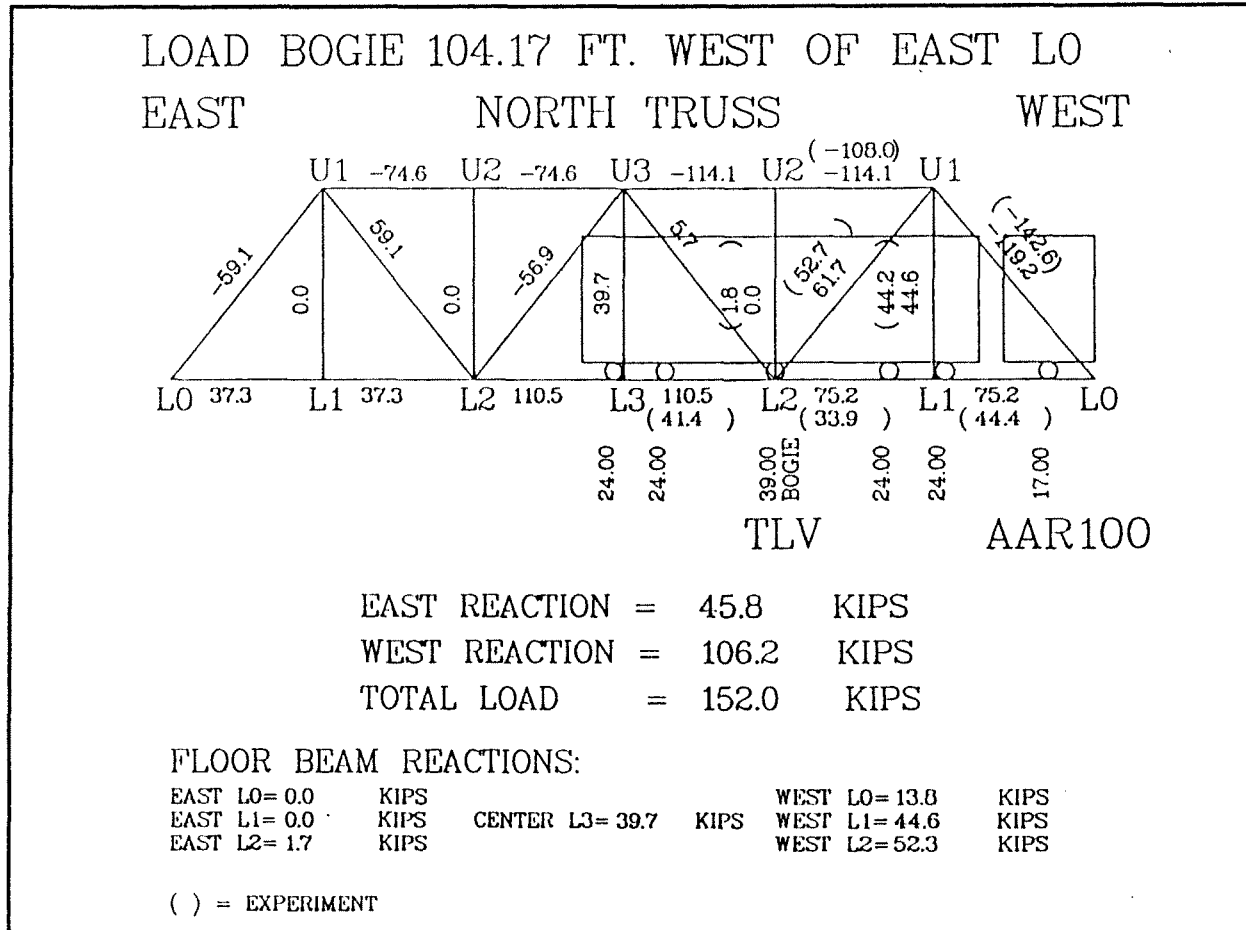

Exhibit A9. Theoretical and Experimental Axial Forces in North Truss Members due to the Stationary TLV Test Consist with Bogie-Wheelset Static Load of 39 Tons Applied on West Floor Beam L2L2.

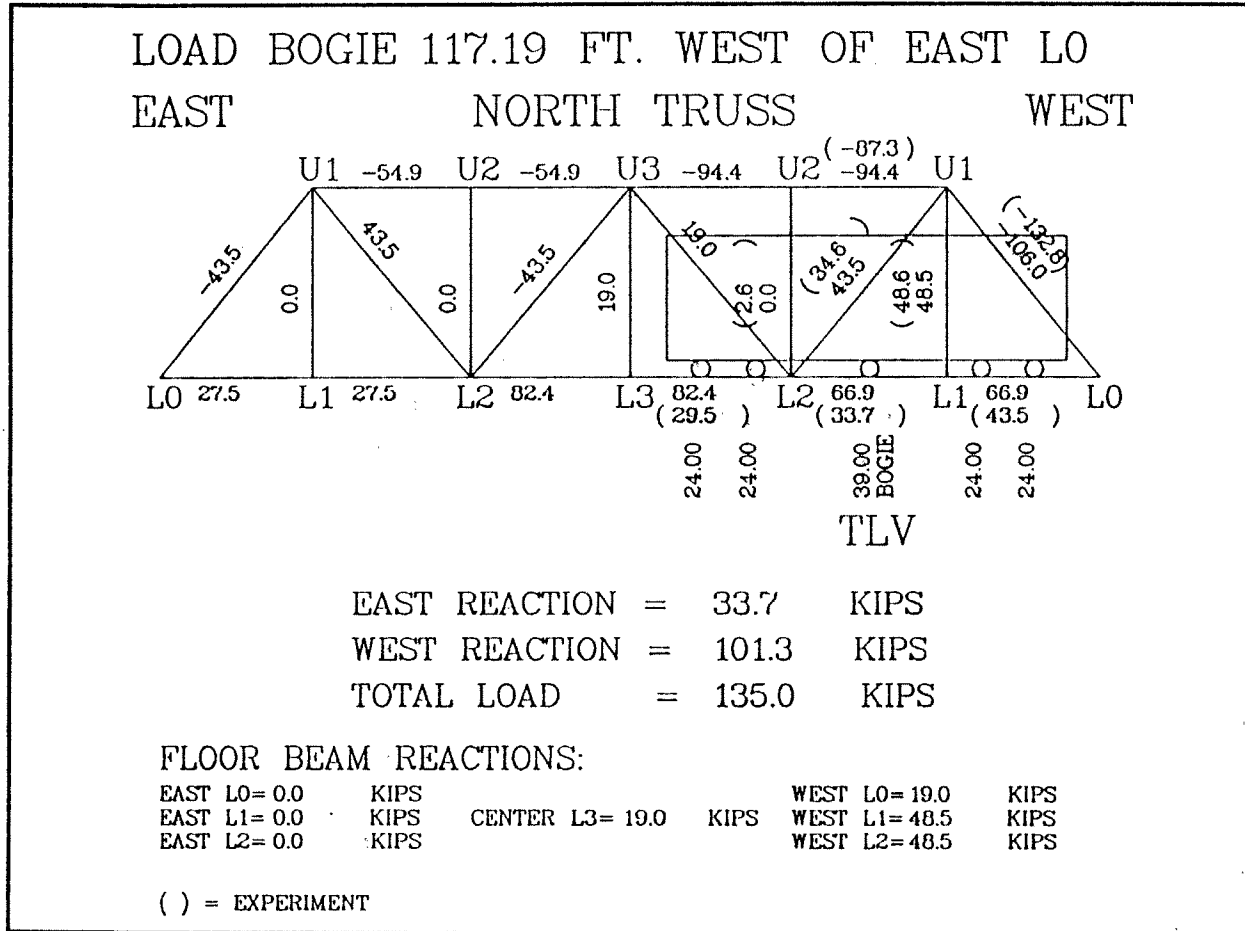

Exhibit A10. Theoretical and Experimental Axial Forces in North Truss Members due to the Stationary TLV Test Consist with Bogie-Wheelset Static Load of 39 Tons Applied on West Bridge Panel L1L2.

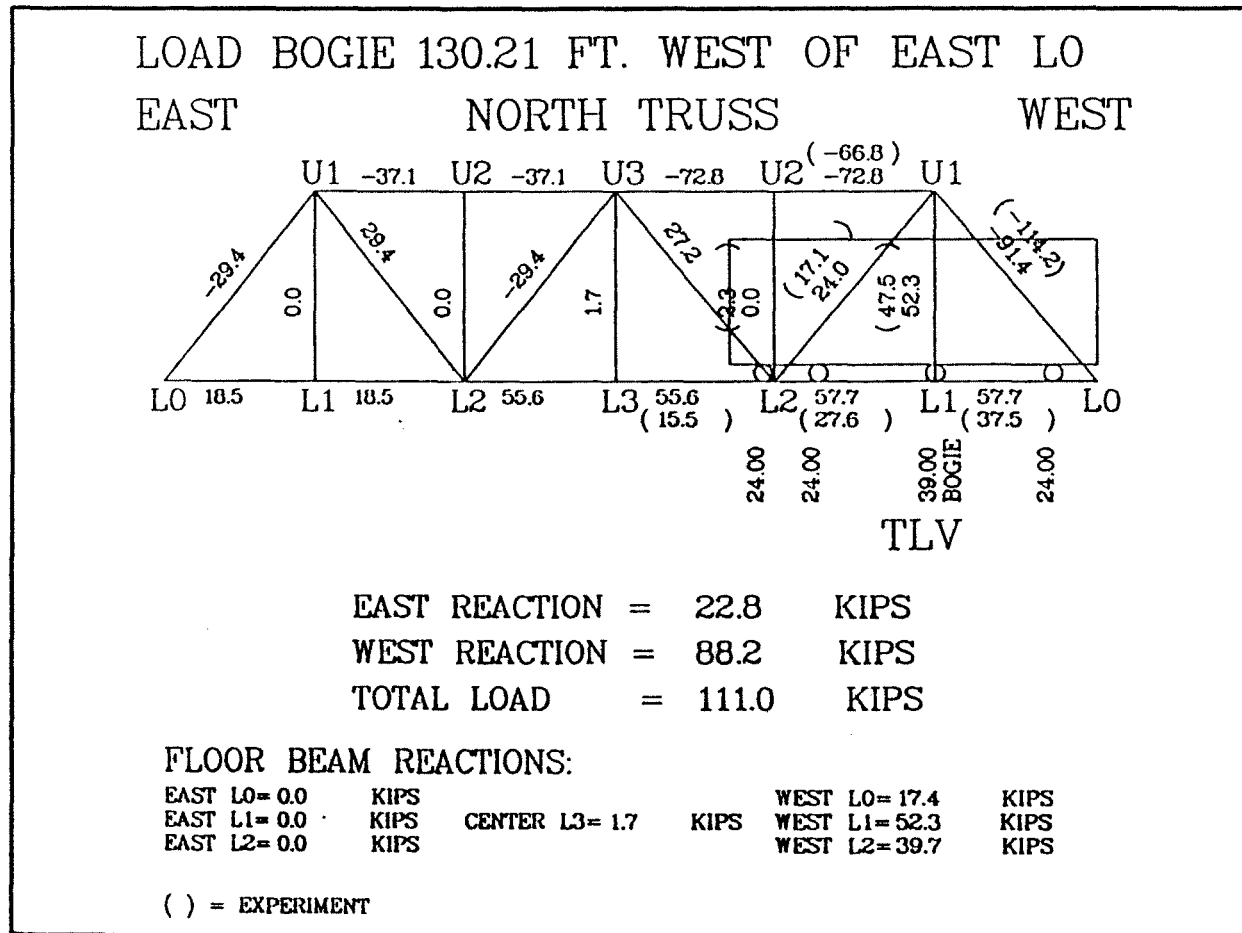

Exhibit A11. Theoretical and Experimental Axial Forces in North Truss Members due to the Stationary TLV Test Consist with Bogie-Wheelset Static Load of 39 Tons Applied on West Floor Beam L1L1.

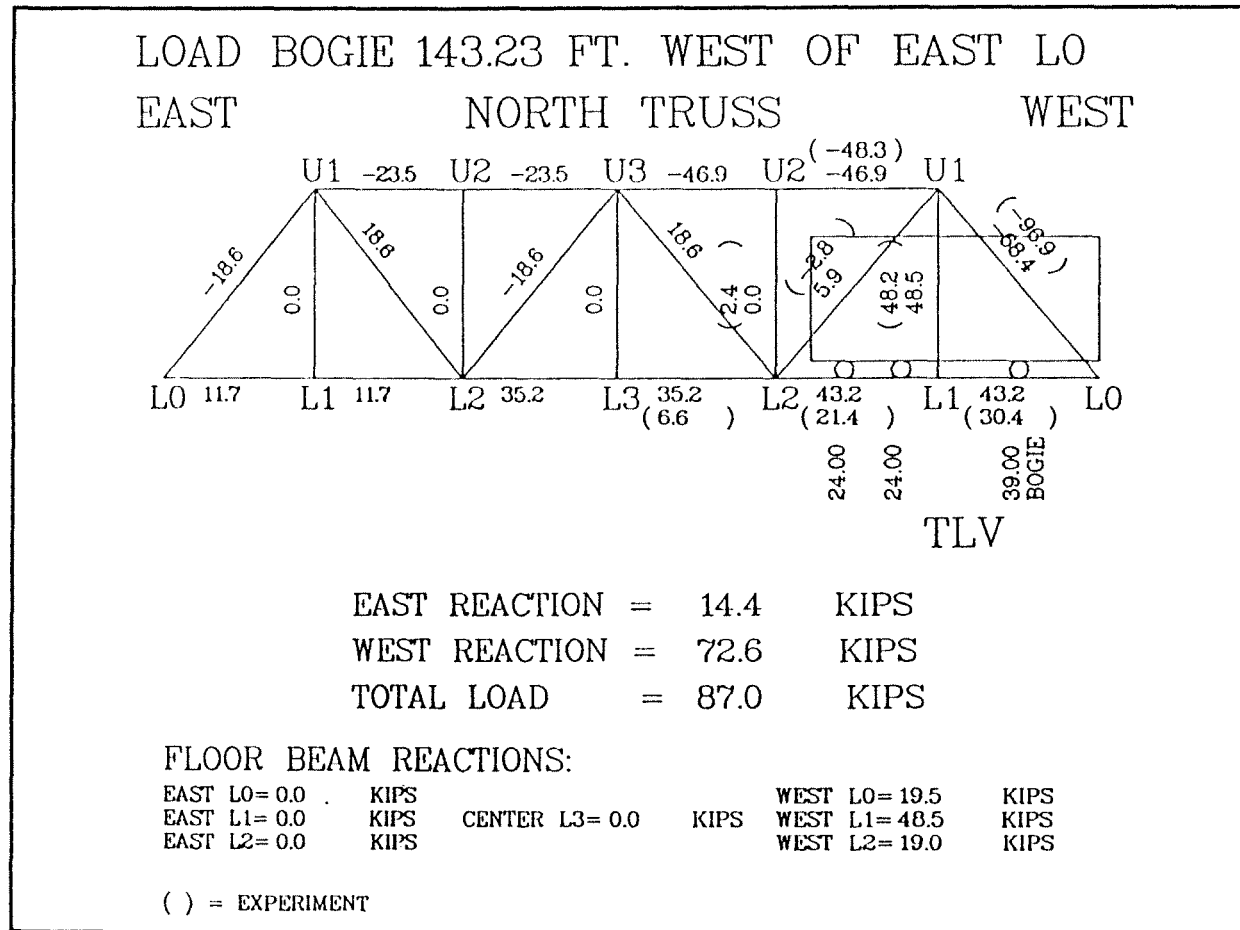

Exhibit A12. Theoretical and Experimental Axial Forces in North Truss Members due to the Stationary TLV Test Consist with Bogie-Wheelset Static Load of 39 Tons Applied on West Bridge Panel L0L1.

8.2 APPENDIX B: The TLV Influence Lines

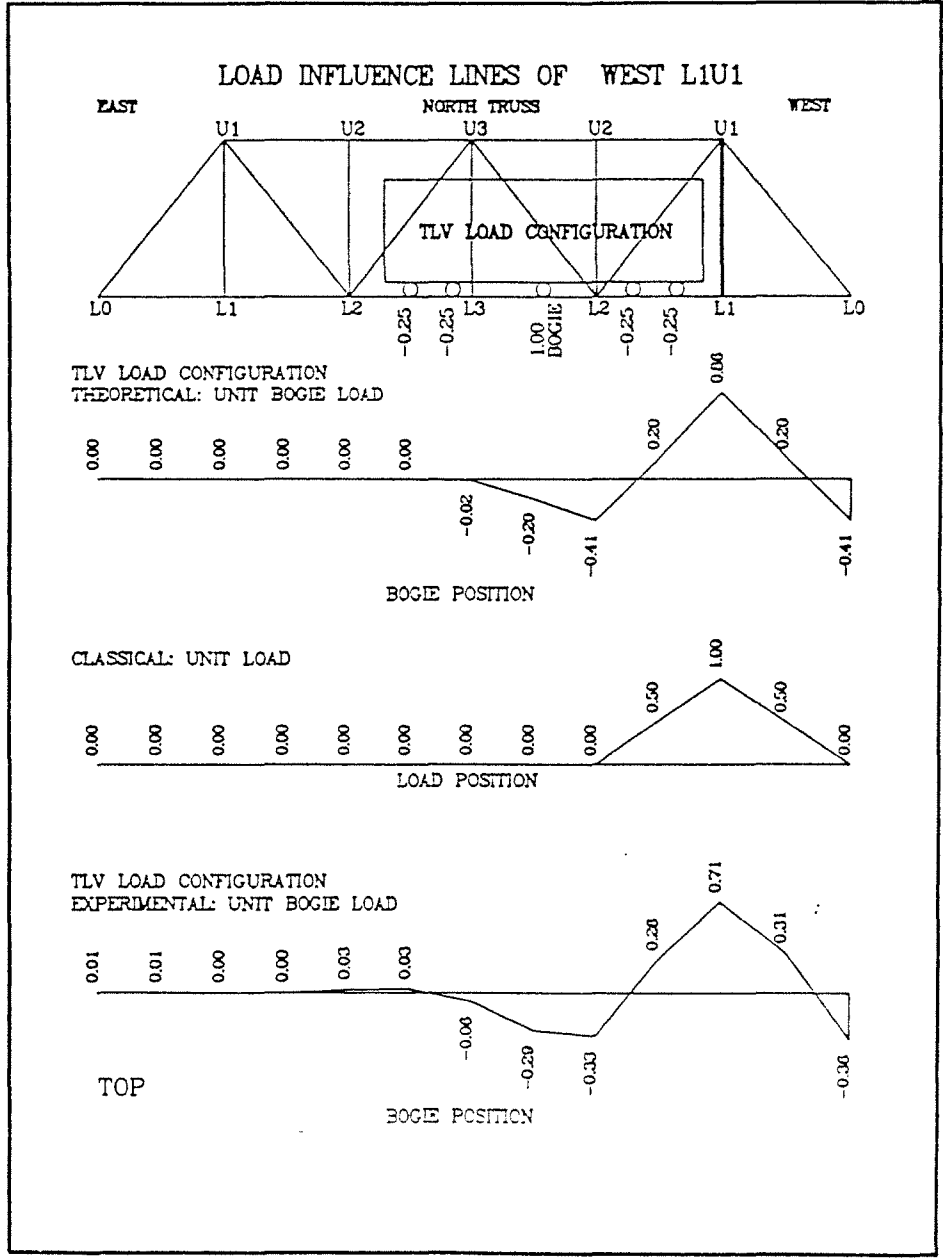

Exhibit B1. Influence Lines of Axial Force in West Hanger L1U1 (Upper End) of North Truss by Using the TLV-Load-Configuration Concept.

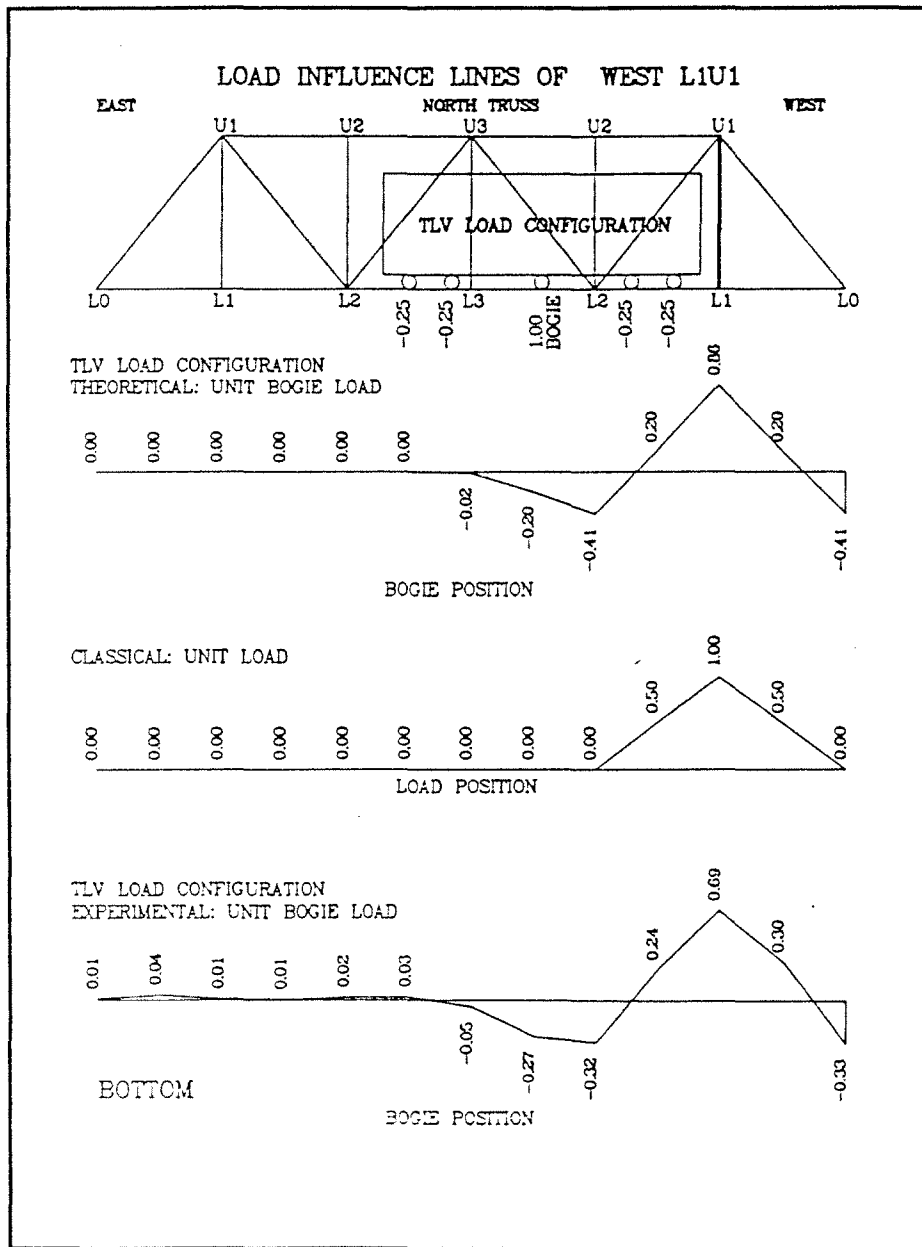

Exhibit B2. Influence Lines of Axial Force in West Hanger L1U1 (Lower End) of North Truss by Using the TLV-Load-Configuration Concept.

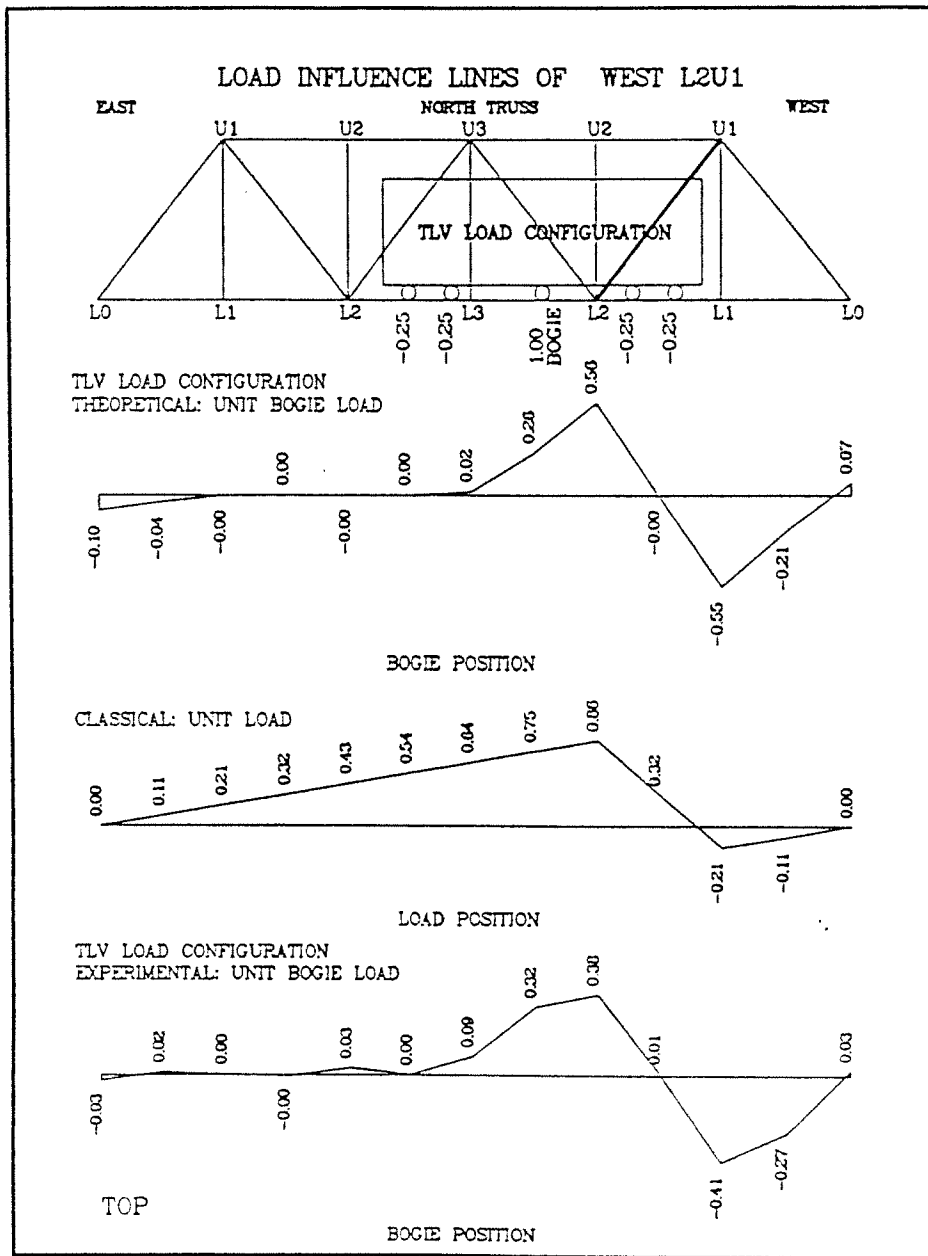

Exhibit B3. Influence Lines of Axial Force in West Diagonal L2U1 (Upper End) of North Truss by Using the TLV-Load-Configuration Concept.

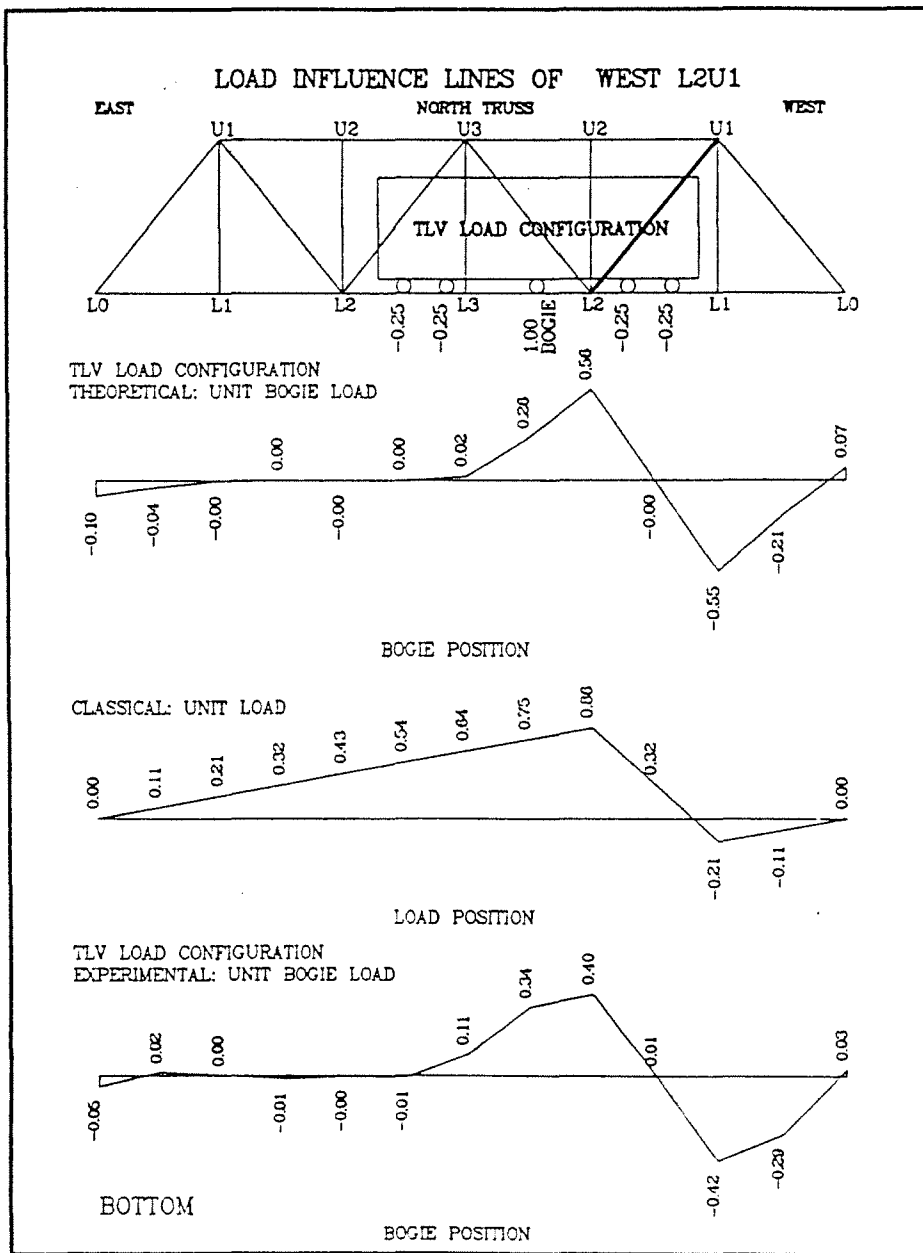

Exhibit B4. Influence Lines of Axial Force in West Diagonal L2U1 (Lower End) of North Truss by Using the TLV-Load-Configuration Concept.

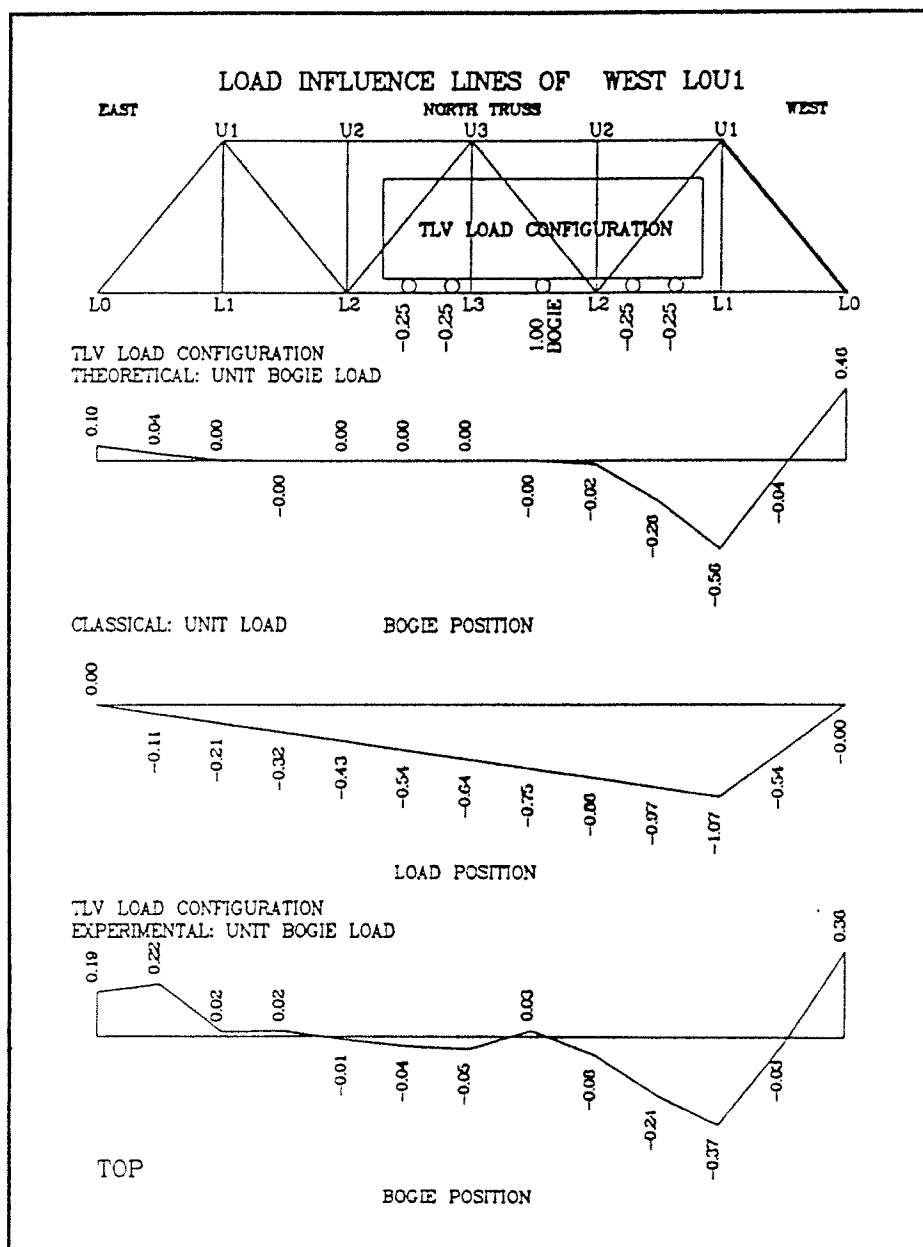

Exhibit B5. Influence Lines of Axial Force in West End Post LOU1 (Upper End) of North Truss by Using the TLV-Load-Configuration Concept.

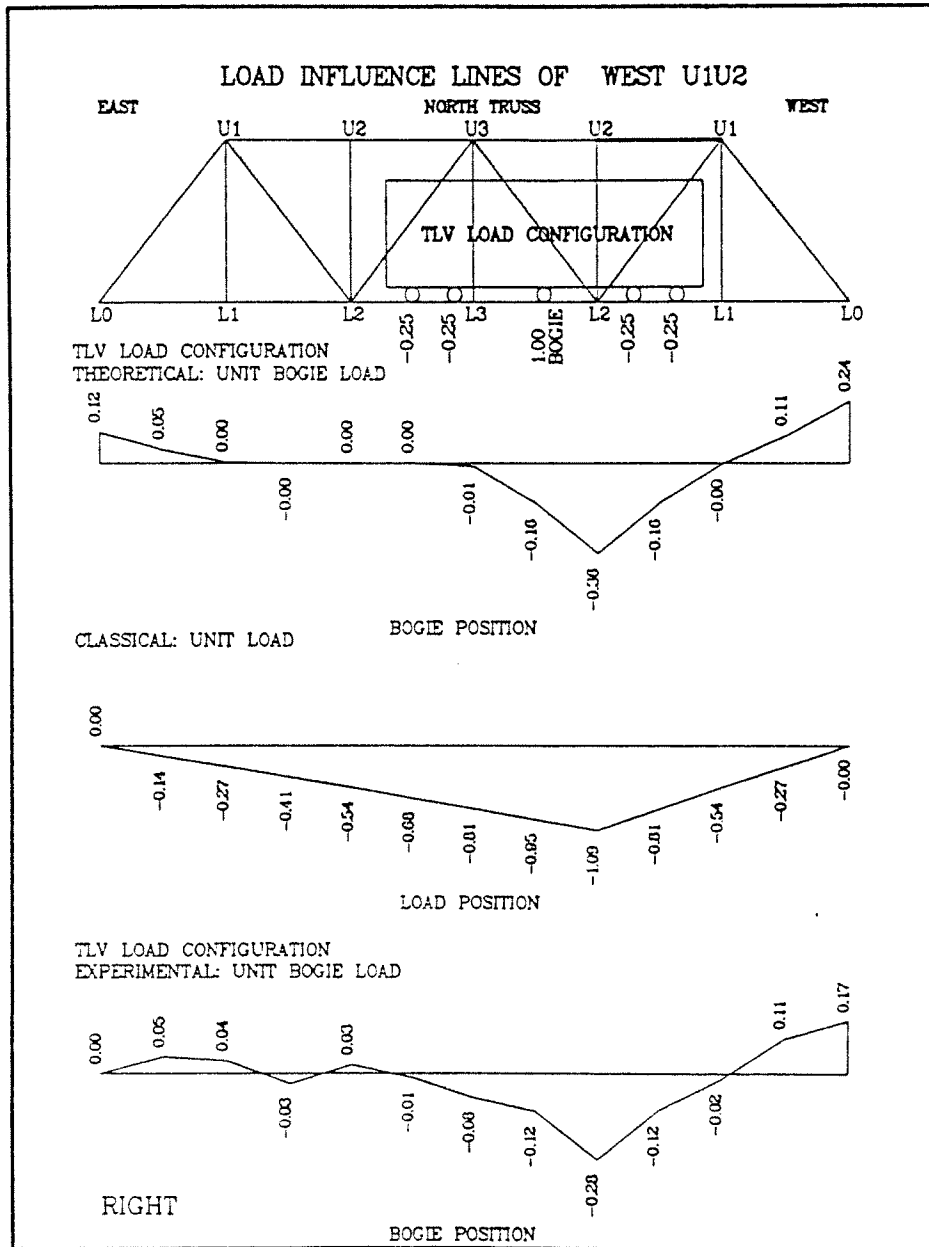

Exhibit B6. Influence Lines of Axial Force in West Top Chord U1U2 (Right End) of North Truss by Using the TLV-Load-Configuration Concept.

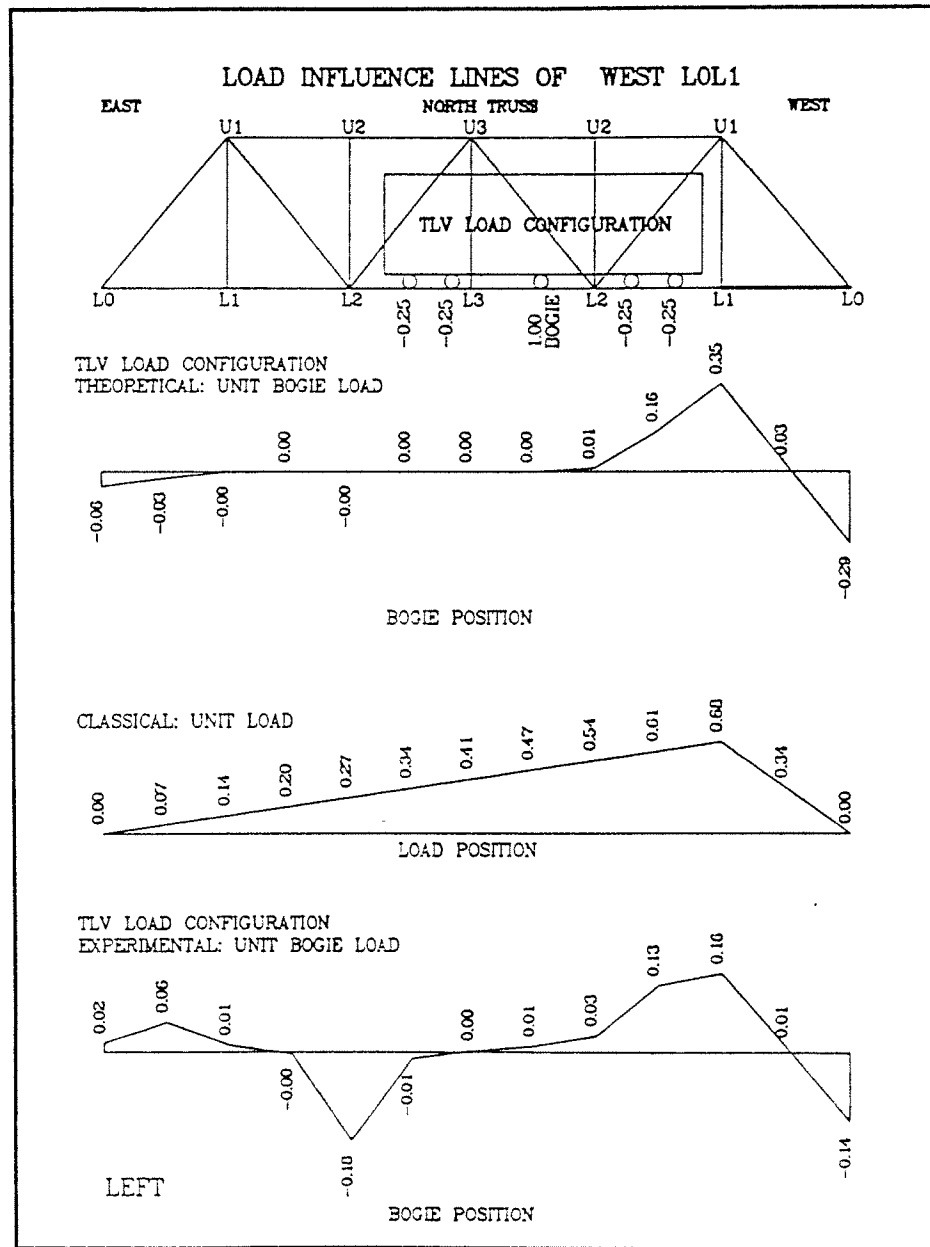

Exhibit B7. Influence Lines of Axial Force in West Bottom Chord L0L1 (Left End) of North Truss by Using the TLV-Load-Configuration Concept.

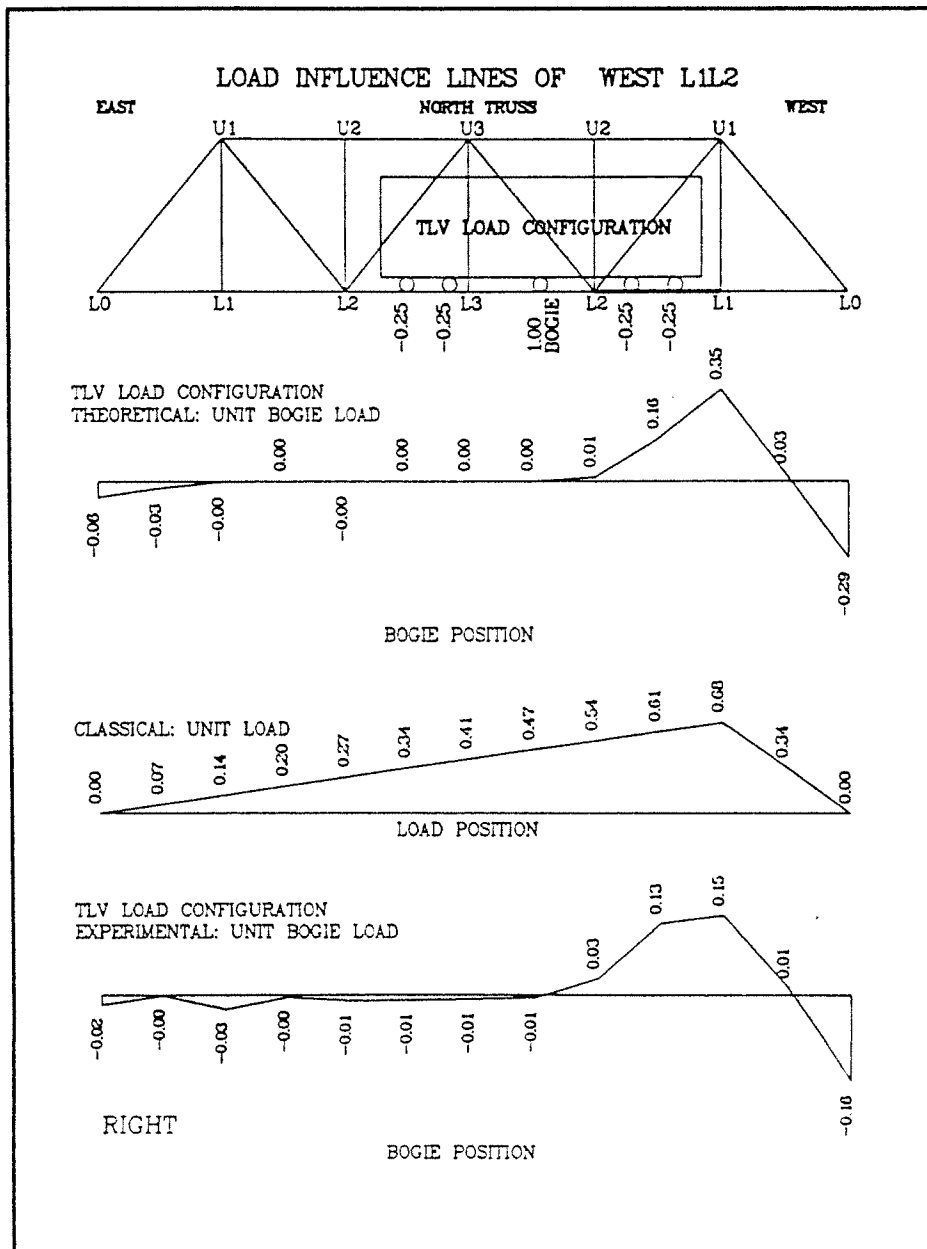

Exhibit B8. Influence Lines of Axial Force in West Bottom Chord L1L2 (Right End) of North Truss by Using the TLV-Load-Configuration Concept.

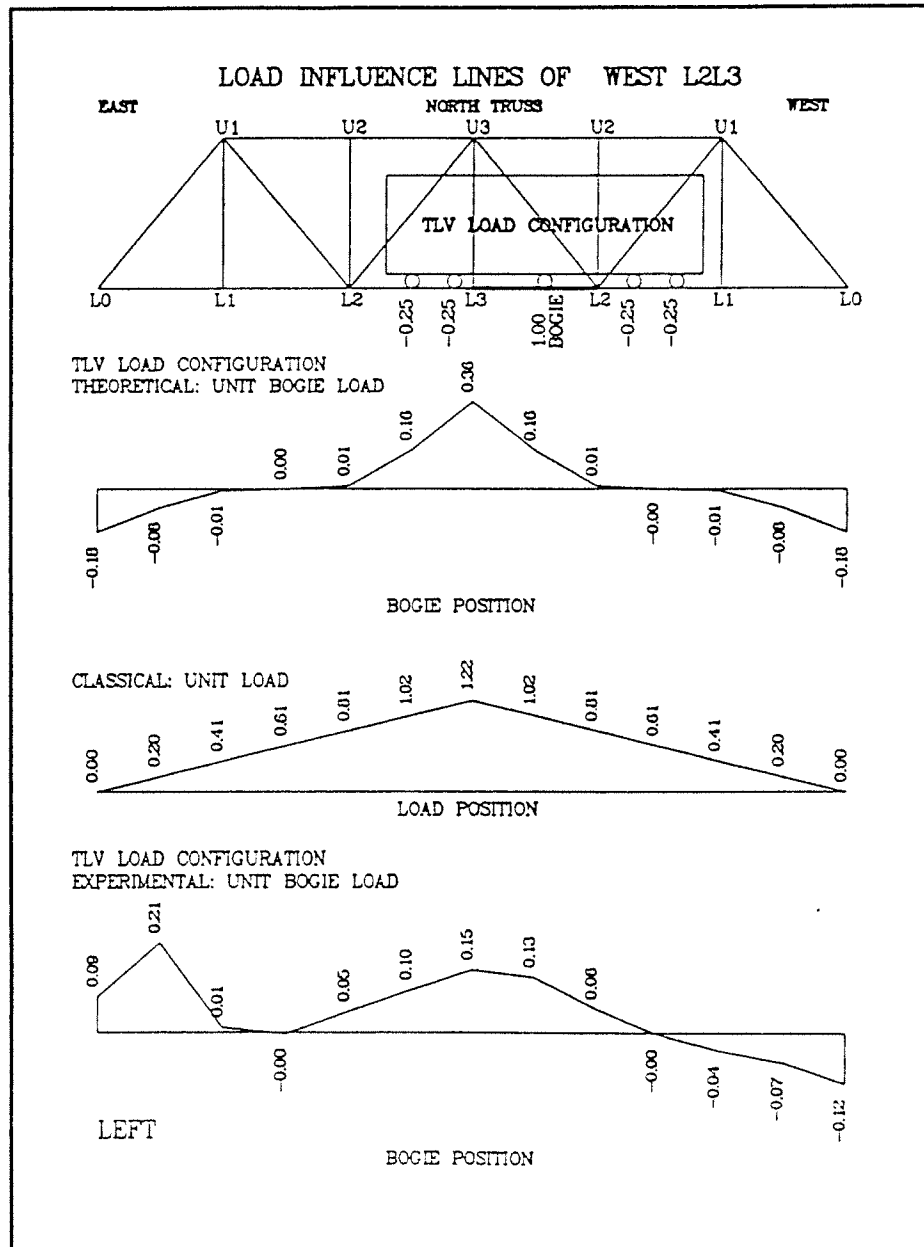

Exhibit B9. Influence Lines of Axial Force in West Bottom Chord L2L3 (Left End) of North Truss by Using the TLV-Load-Configuration Concept.

8.3 APPENDIX C: The TLV Impact Percentages

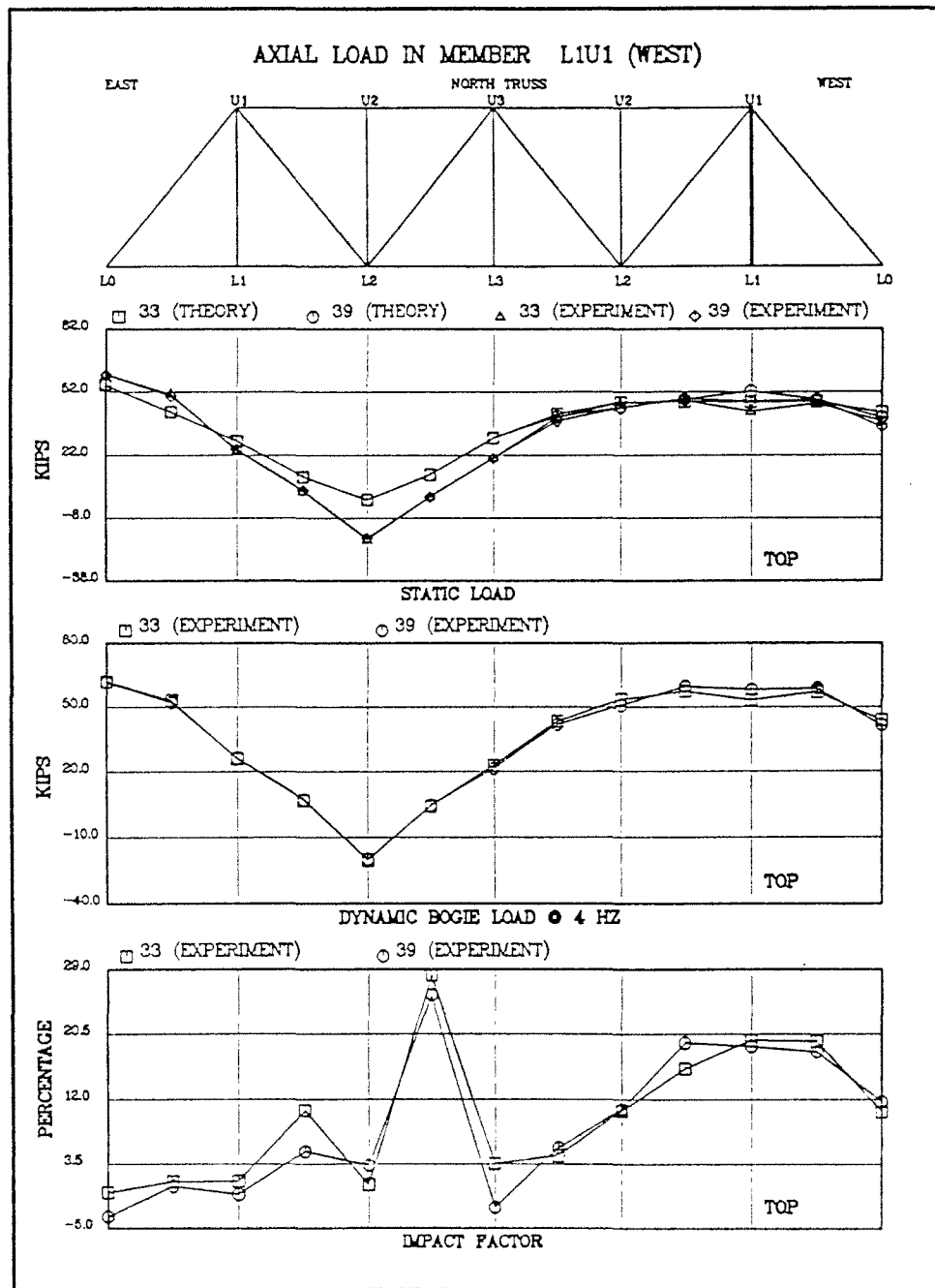

Exhibit C1. Variation of Impact Percentages and Maximum Axial Forces in West Hanger L1U1 (Upper End) of North Truss due to the TLV Consist at Various Locations on the Bridge.

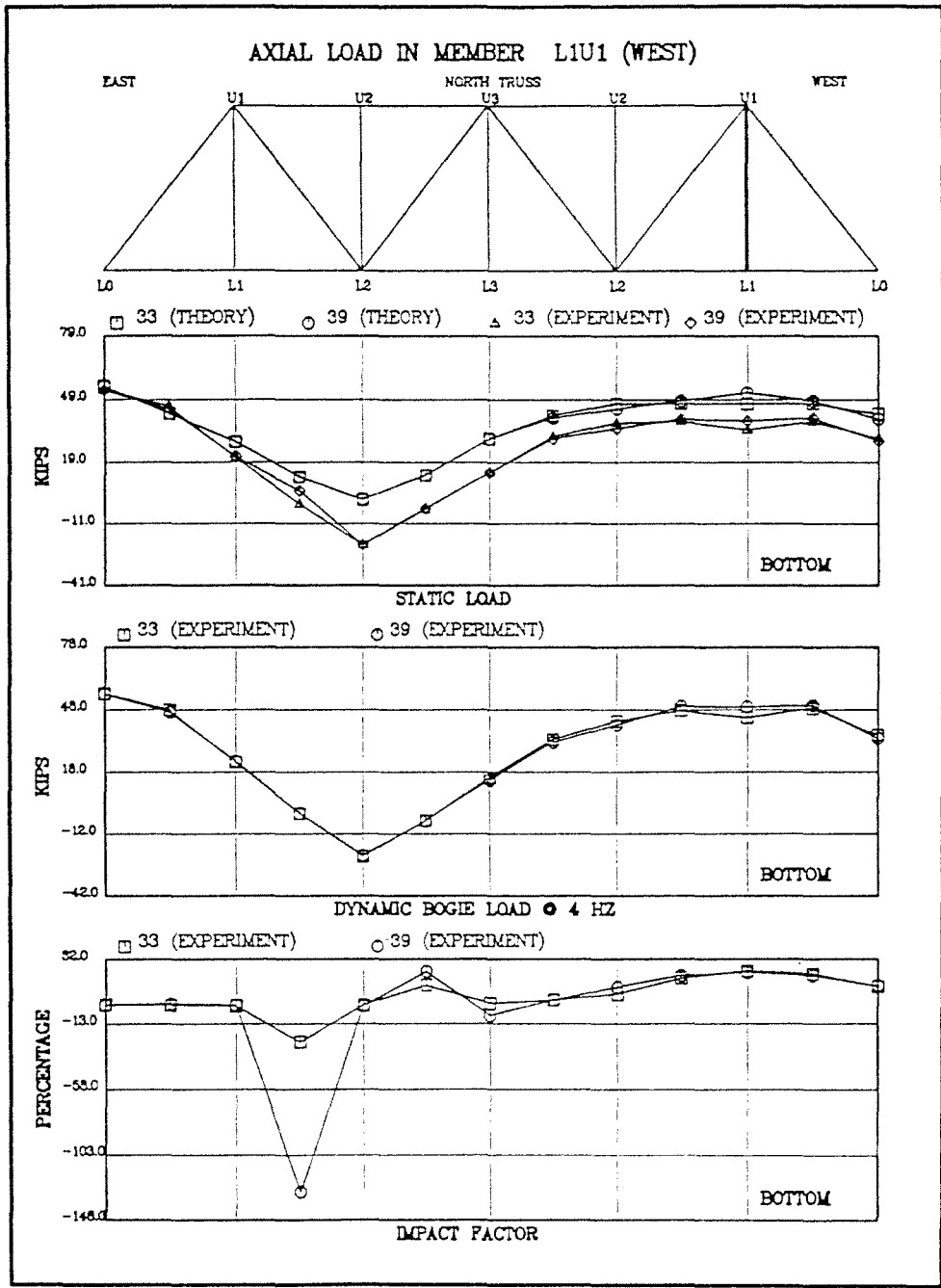

Exhibit C2. Variation of Impact Percentages and Maximum Axial Forces in West Hanger L1U1 (Lower End) of North Truss due to the TLV Consist at Various Locations on the Bridge.

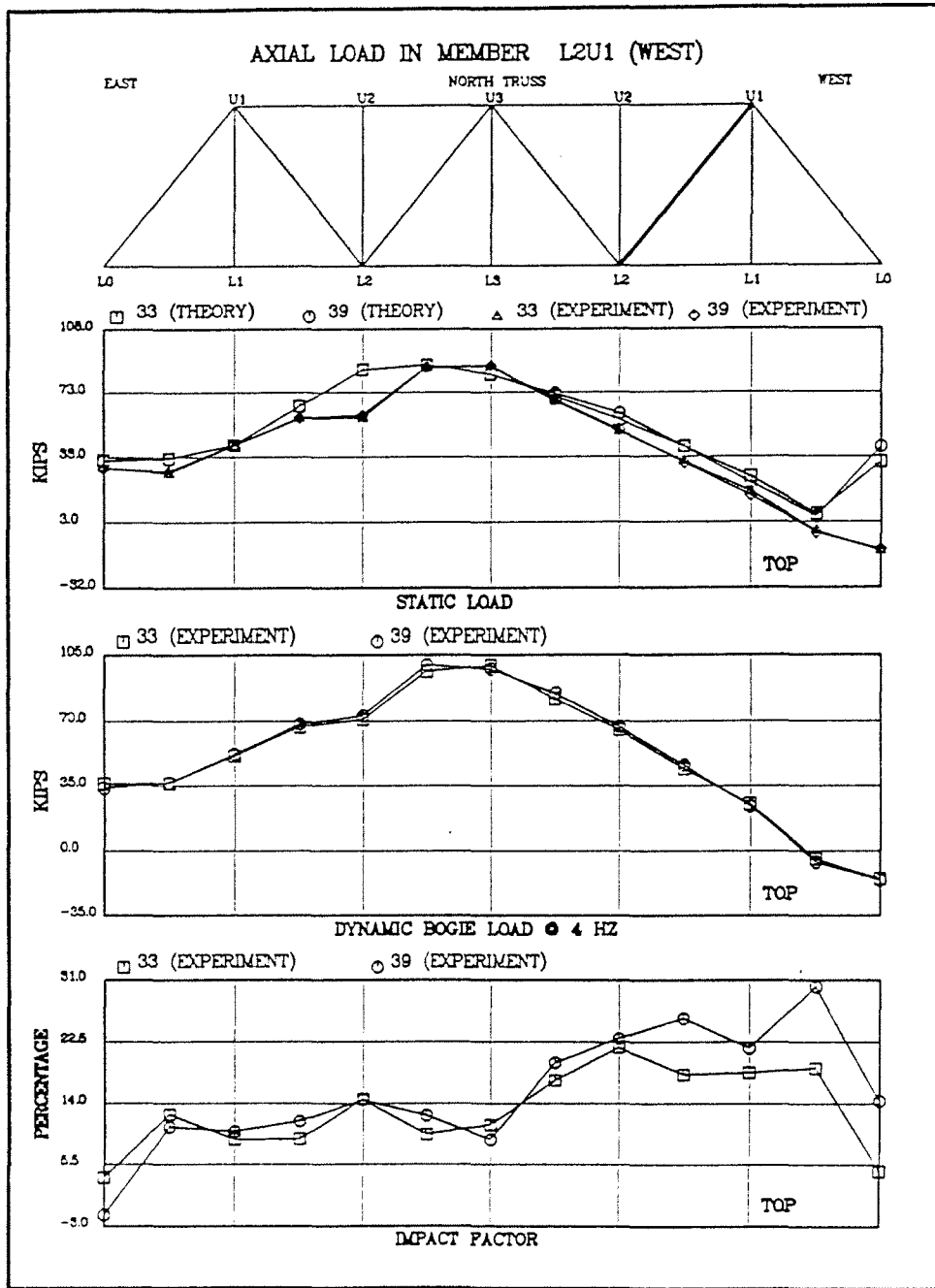

Exhibit C3. Variation of Impact Percentages and Maximum Axial Forces in West Diagonal L2U1 (Upper End) of North Truss due to the TLV Consist at Various Locations on the Bridge.

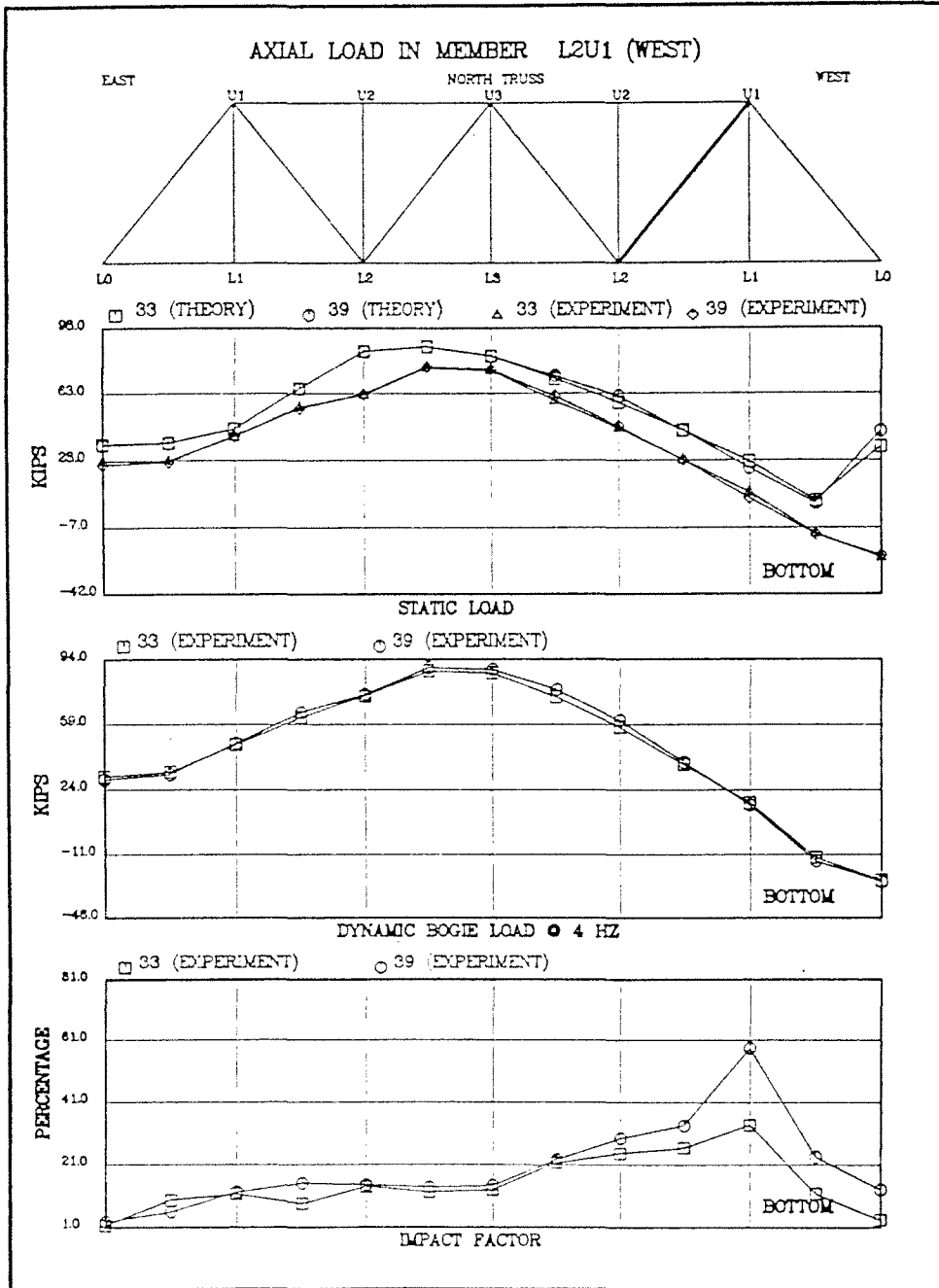

Exhibit C4. Variation of Impact Percentages and Maximum Axial Forces in West Diagonal L2U1 (Lower End) of North Truss due to the TLV Consist at Various Locations on the Bridge.

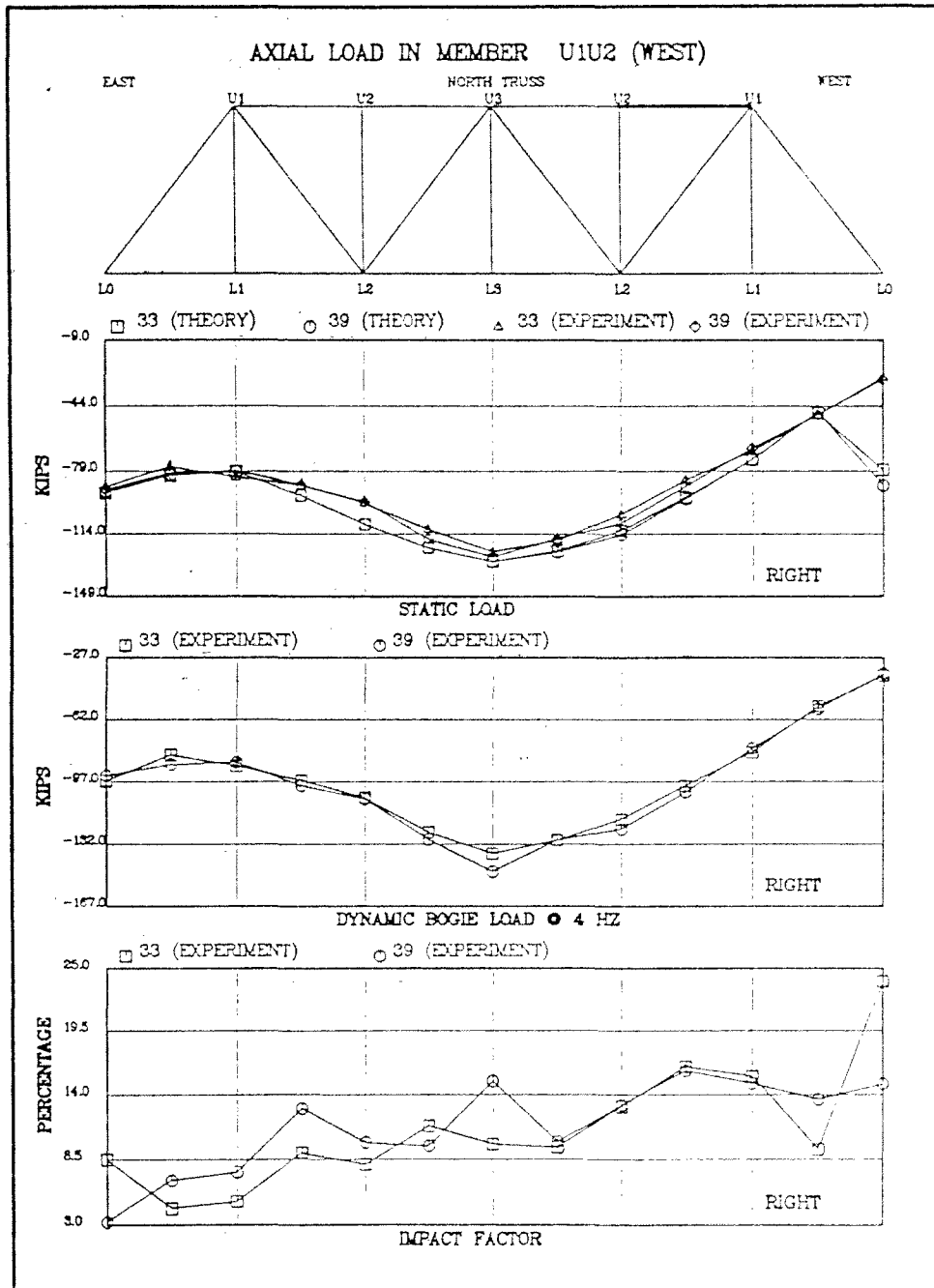

Exhibit C6. Variation of Impact Percentages and Maximum Axial Forces in West Top Chord U1U2 (Right End) of North Truss due to the TLV Consist at Various Locations on the Bridge.

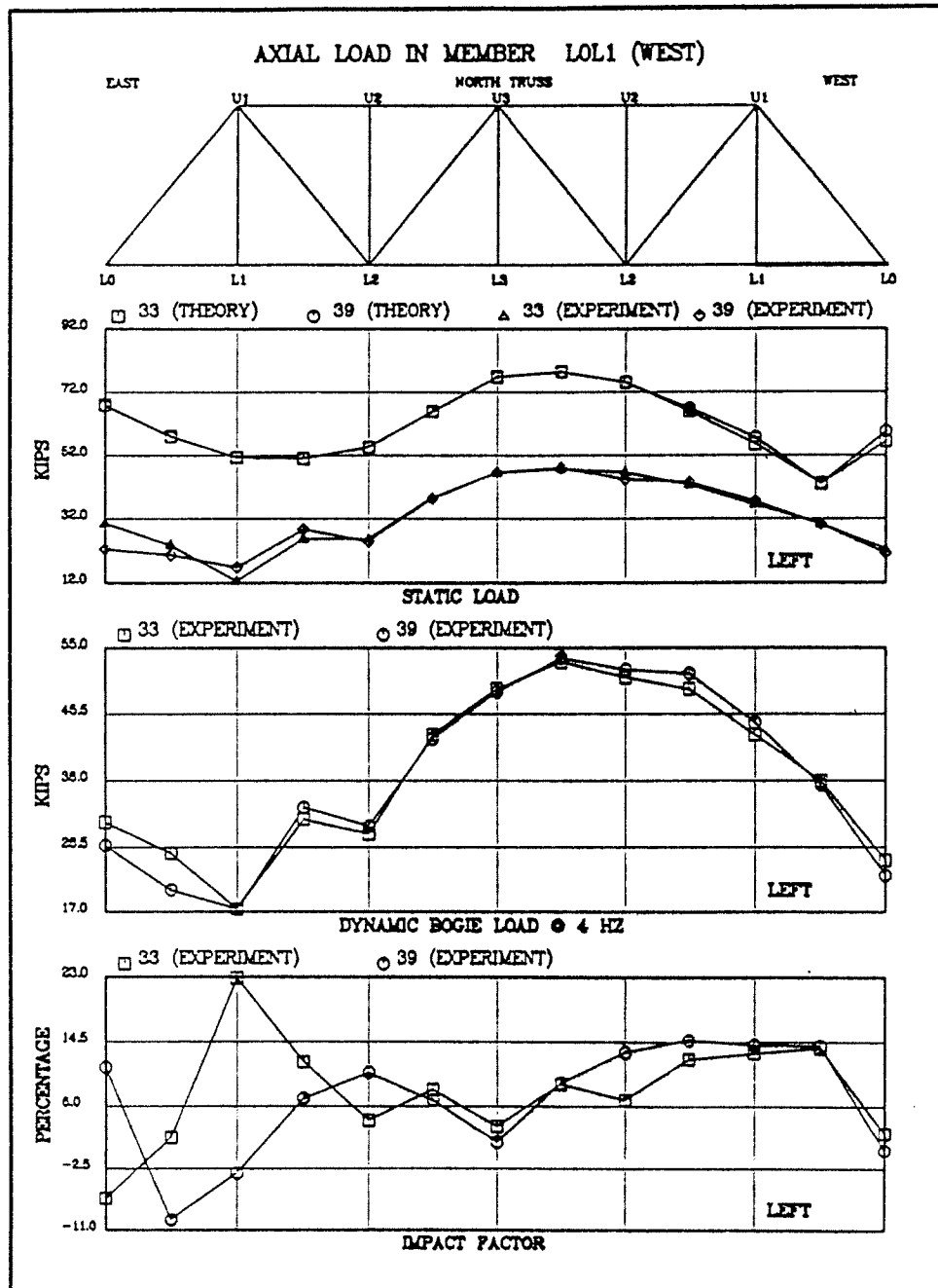

Exhibit C7. Variation of Impact Percentages and Maximum Axial Forces in West Bottom Chord L0L1 (Left End) of North Truss due to the TLV Consist at Various Locations on the Bridge.

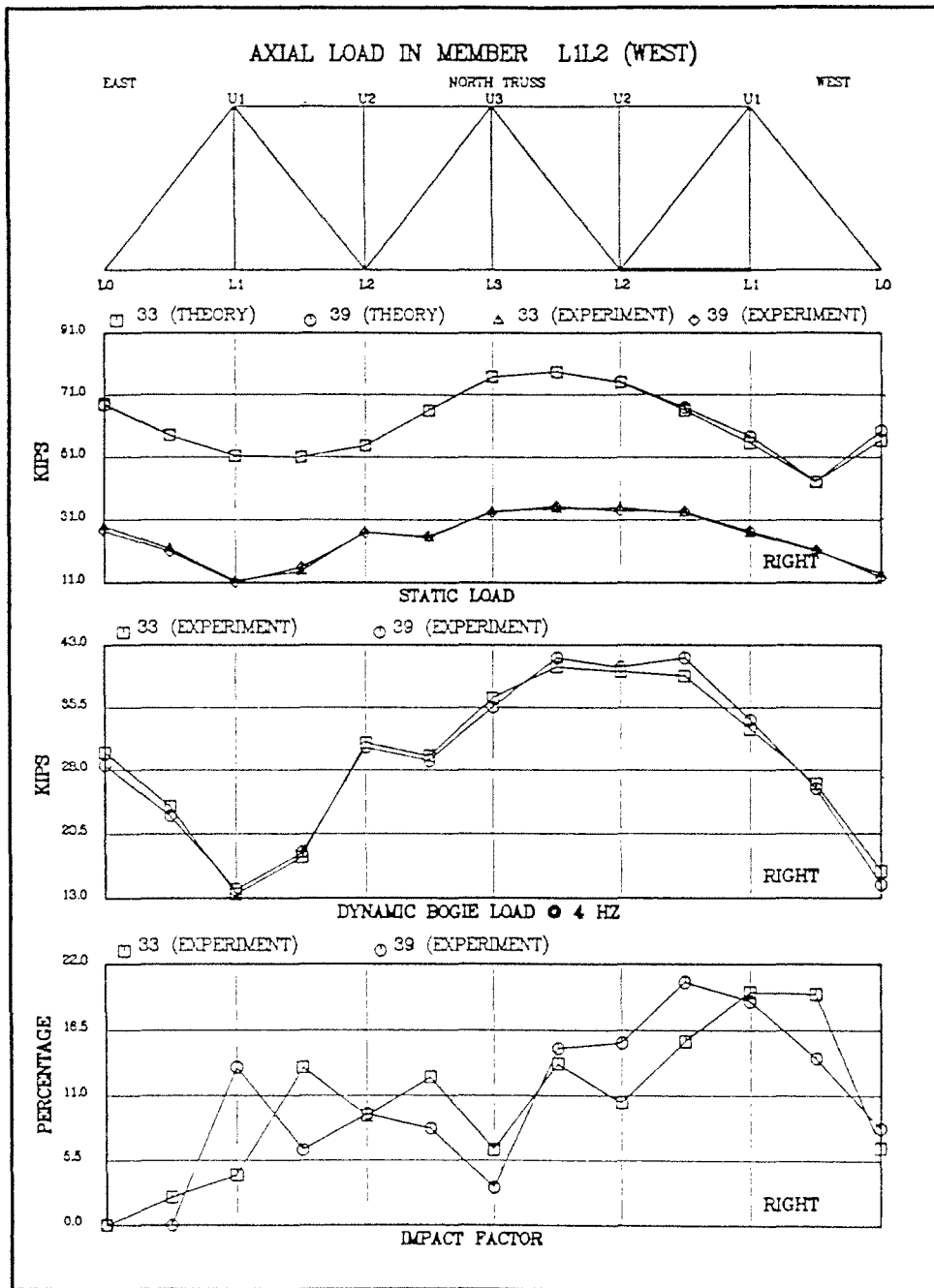

Exhibit C8. Variation of Impact Percentages and Maximum Axial Forces in West Bottom Chord L1L2 (Right End) of North Truss due to the TLV Consist at Various Locations on the Bridge.

8.4 APPENDIX D: Resonance Curves of Members

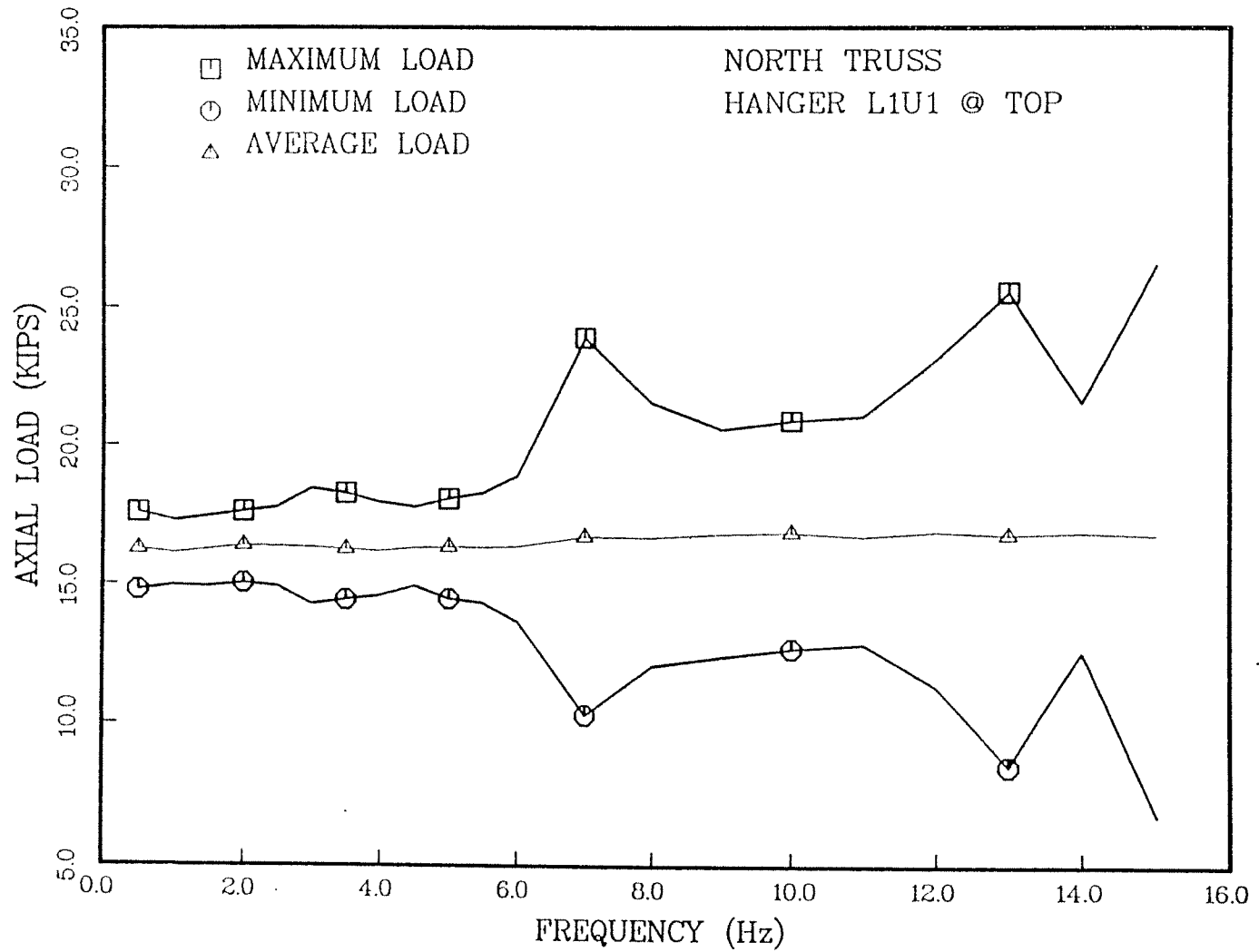

Exhibit D1. Resonance Curve of the Axial Force in West Hanger L1U1 (Upper End) of North Truss from the Results of the TLV Steady-State Sinusoidal Tests on the Bridge.

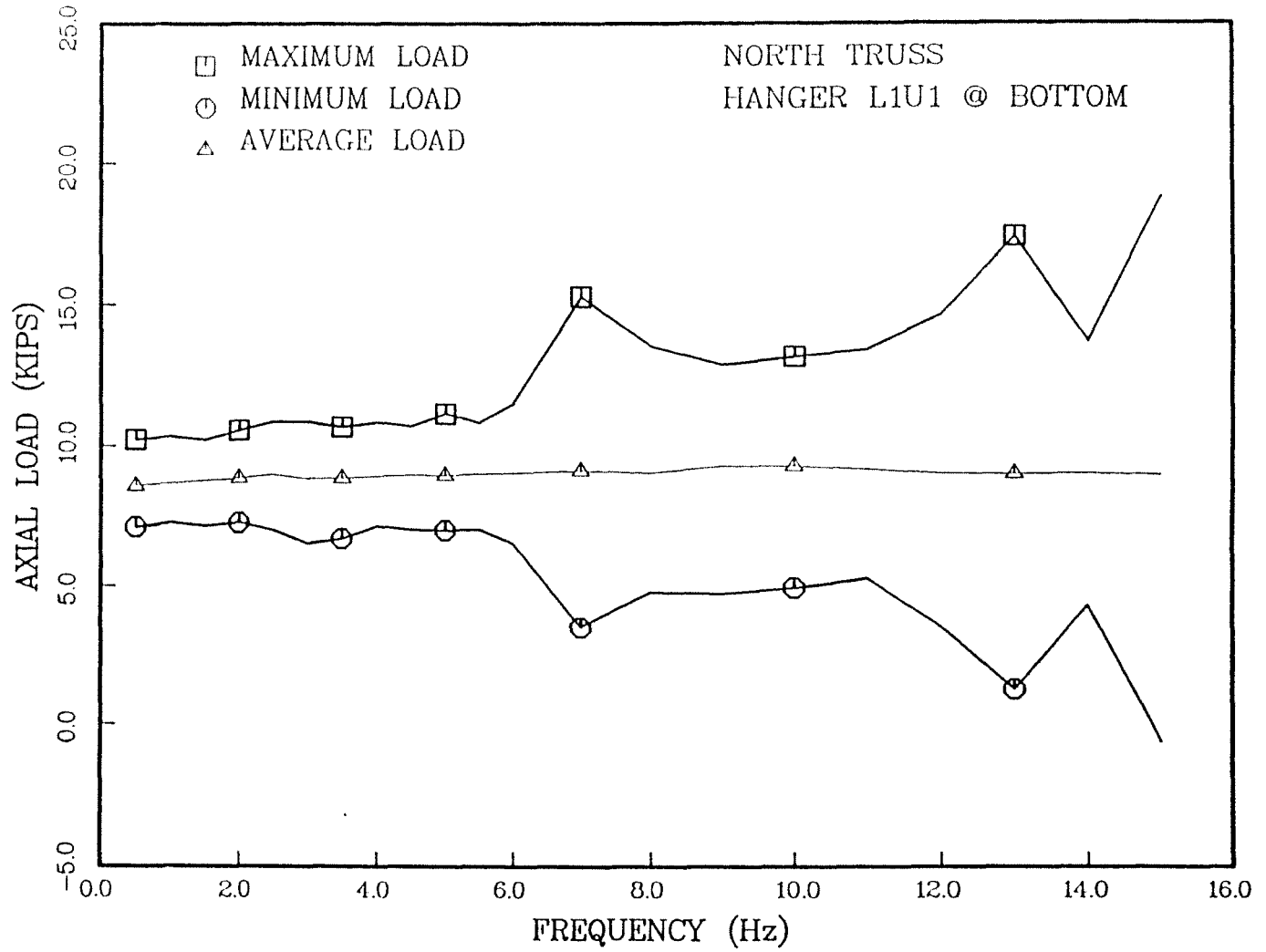

Exhibit D2. Resonance Curve of the Axial Force in West Hanger L1U1 (Lower End) of North Truss from the Results of the TLV Steady-State Sinusoidal Tests on the Bridge.

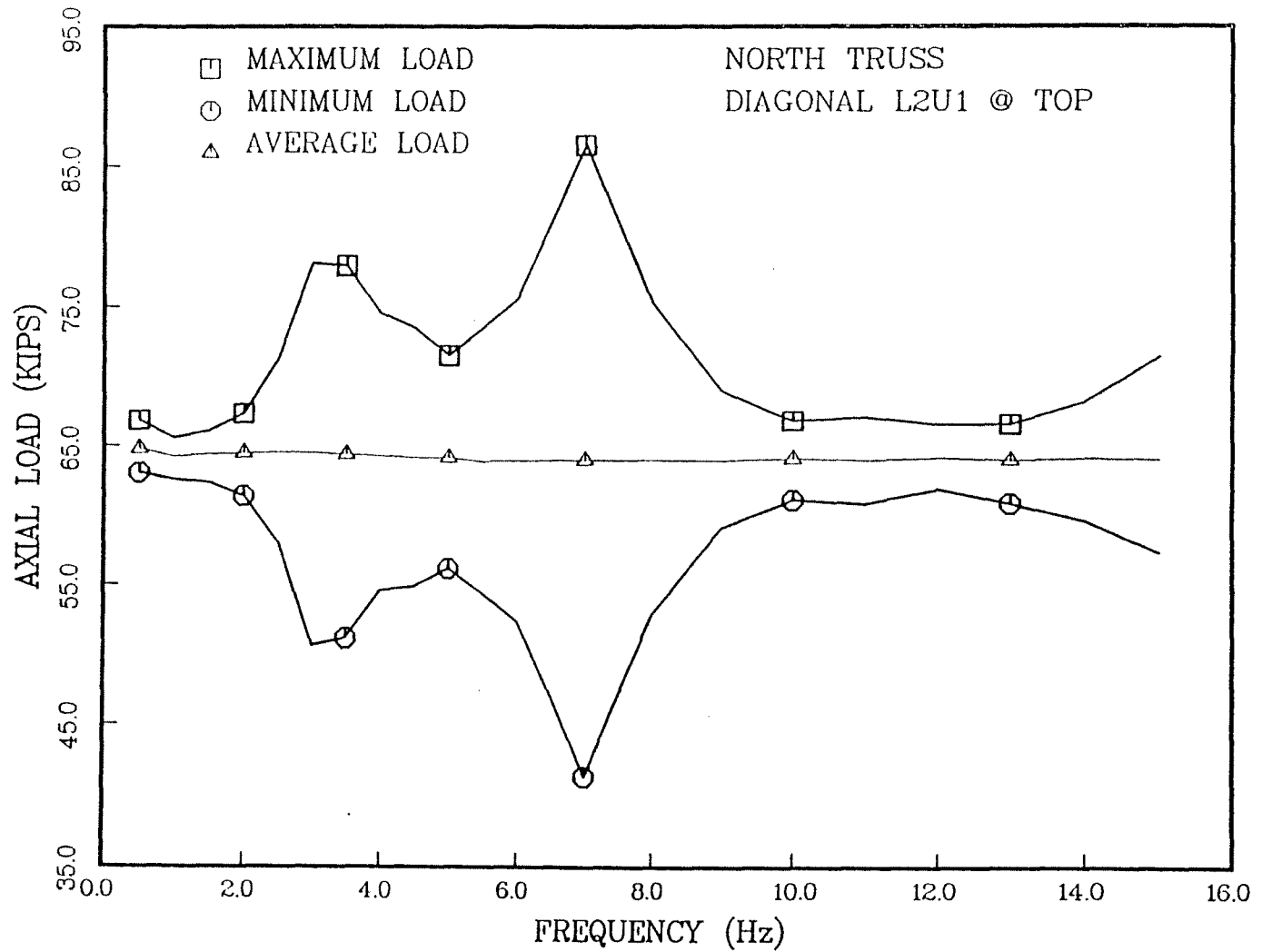

Exhibit D3. Resonance Curve of the Axial Force in West Diagonal L2U1 (Upper end) of North Truss from the Results of the TLV Steady-State Sinusoidal Tests on the Bridge.

D-5

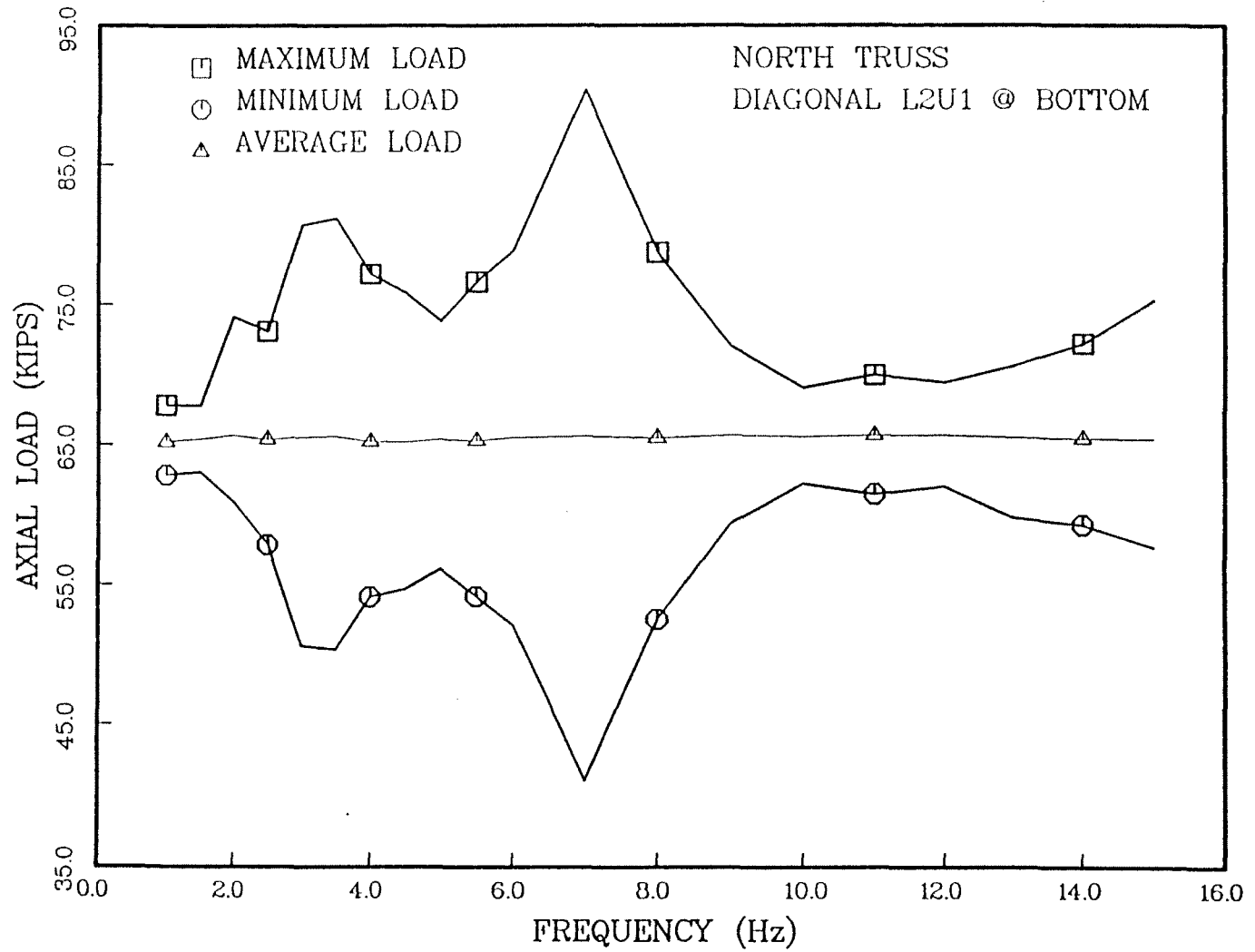

Exhibit D4. Resonance Curve of the Axial Force in West Diagonal L2U1 (Lower End) of North Truss from the Results of the TLV Steady-State Sinusoidal Tests on the Bridge.

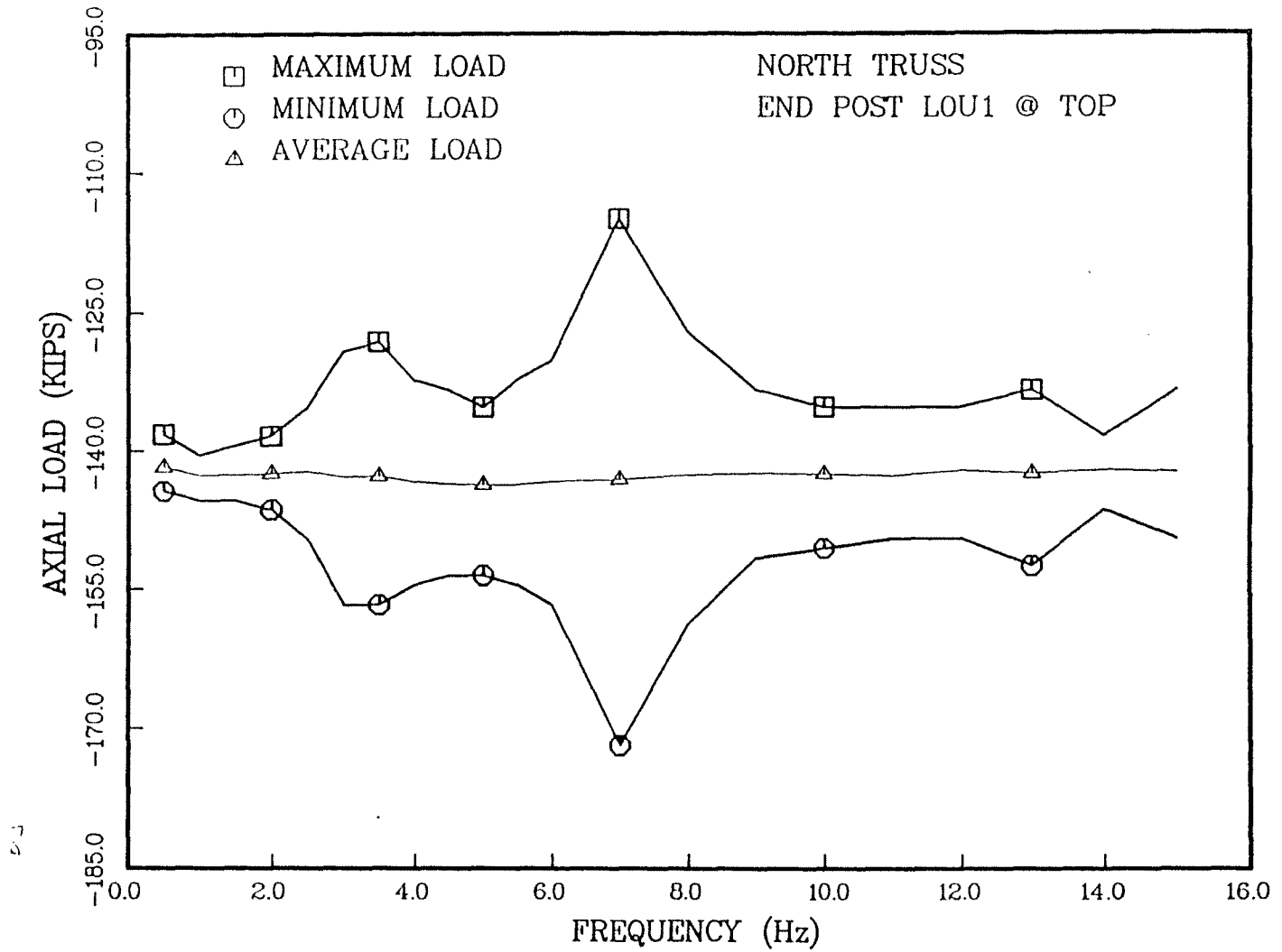

Exhibit D5. Resonance Curve of the Axial Force in West End Post L0U1 (Upper End) of North Truss from the Results of the TLV Steady-State Sinusoidal Tests on the Bridge.

D-7

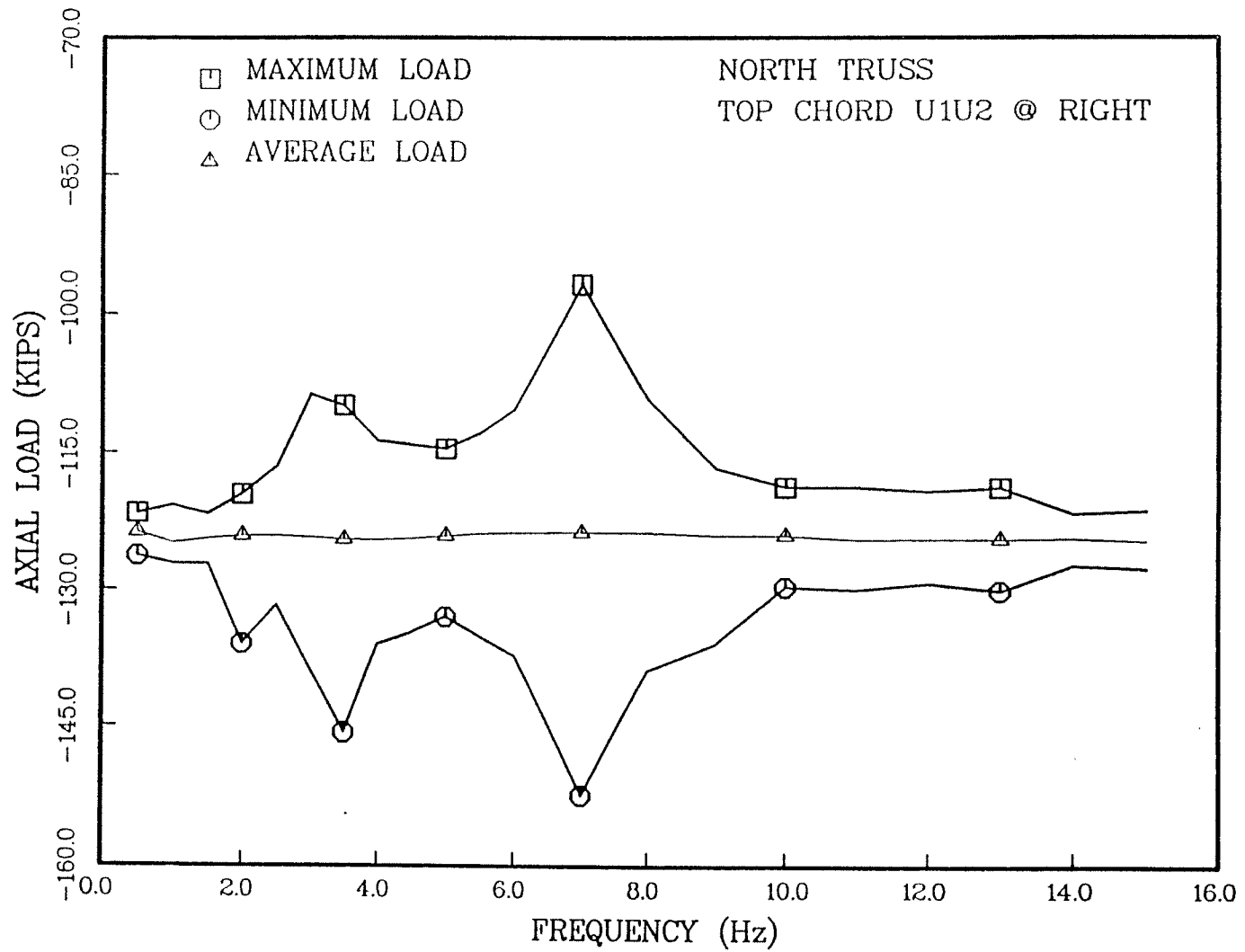

Exhibit D6. Resonance Curve of the Axial Force in West Top Chord U1U2 (Right End) of North Truss from the Results of the TLV Steady-State Sinusoidal Tests on the Bridge.

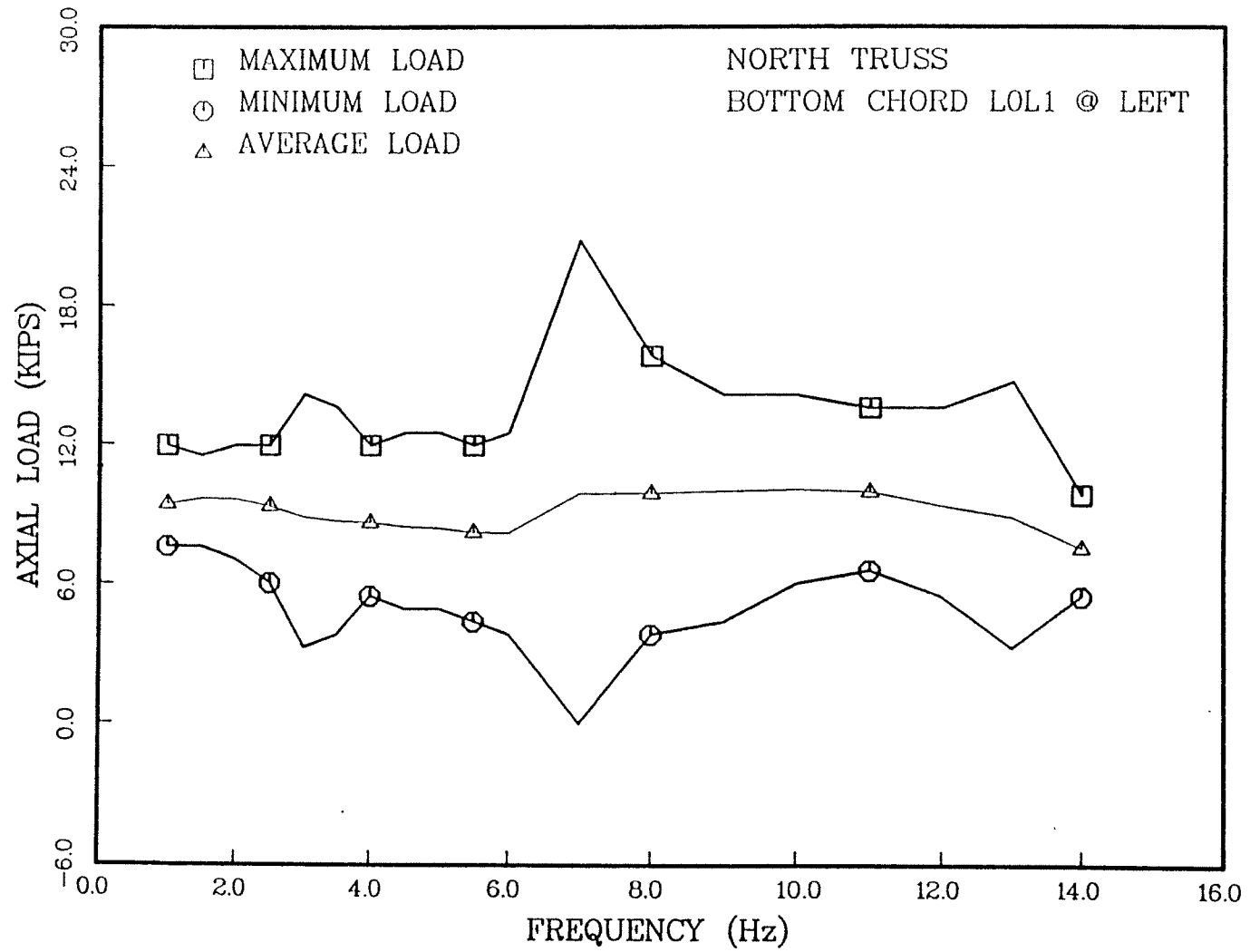

Exhibit D7. Resonance Curve of the Axial Force in West Bottom Chord L0L1 (Left End) of North Truss from the Results of the TLV Steady-State Sinusoidal Tests on the Bridge.

6-D

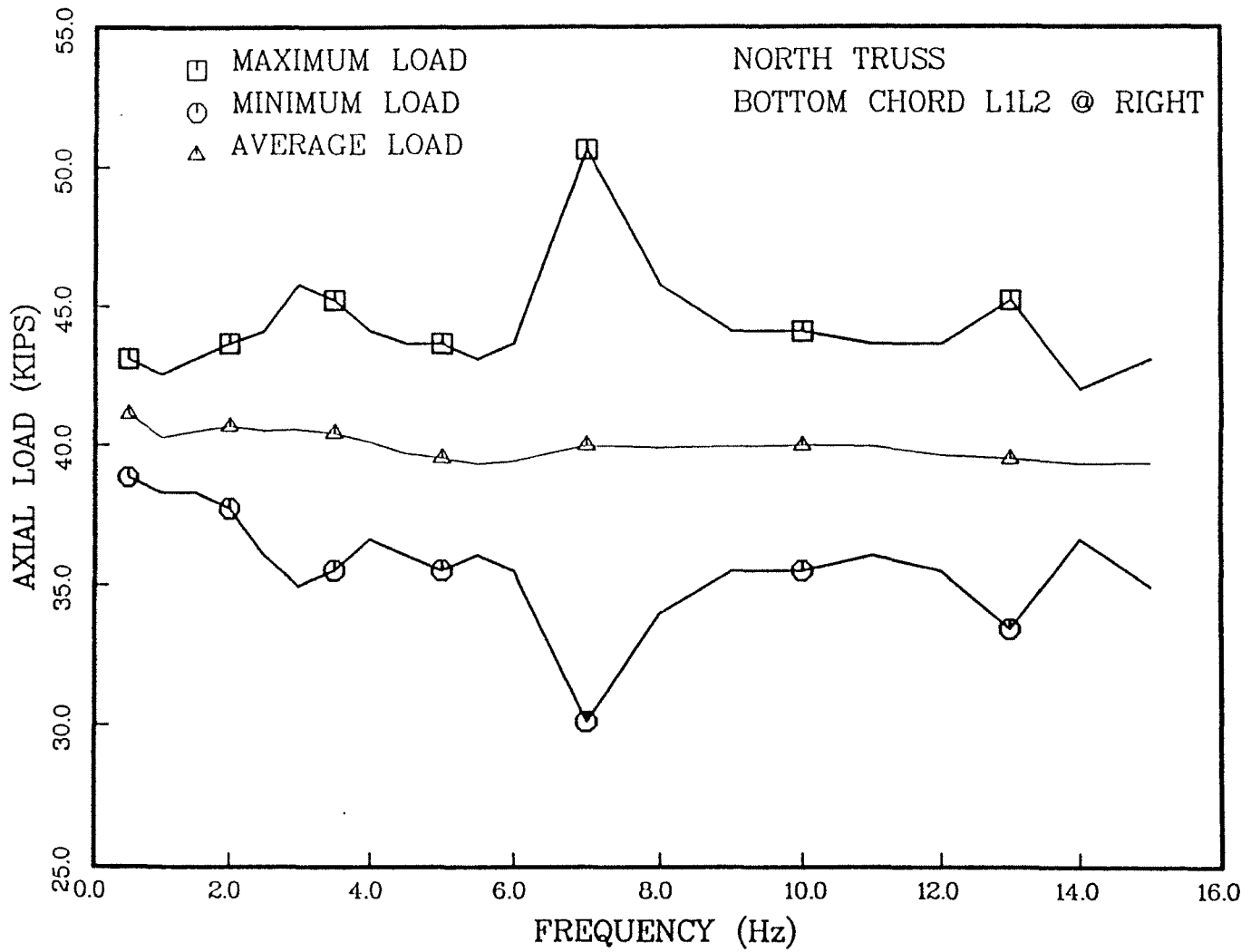

Exhibit D8. Resonance Curve of the Axial Force in West Bottom Chord L1L2 (Right End) of North Truss from the Results of the TLV Steady-State Sinusoidal Tests on the Bridge.

D-10

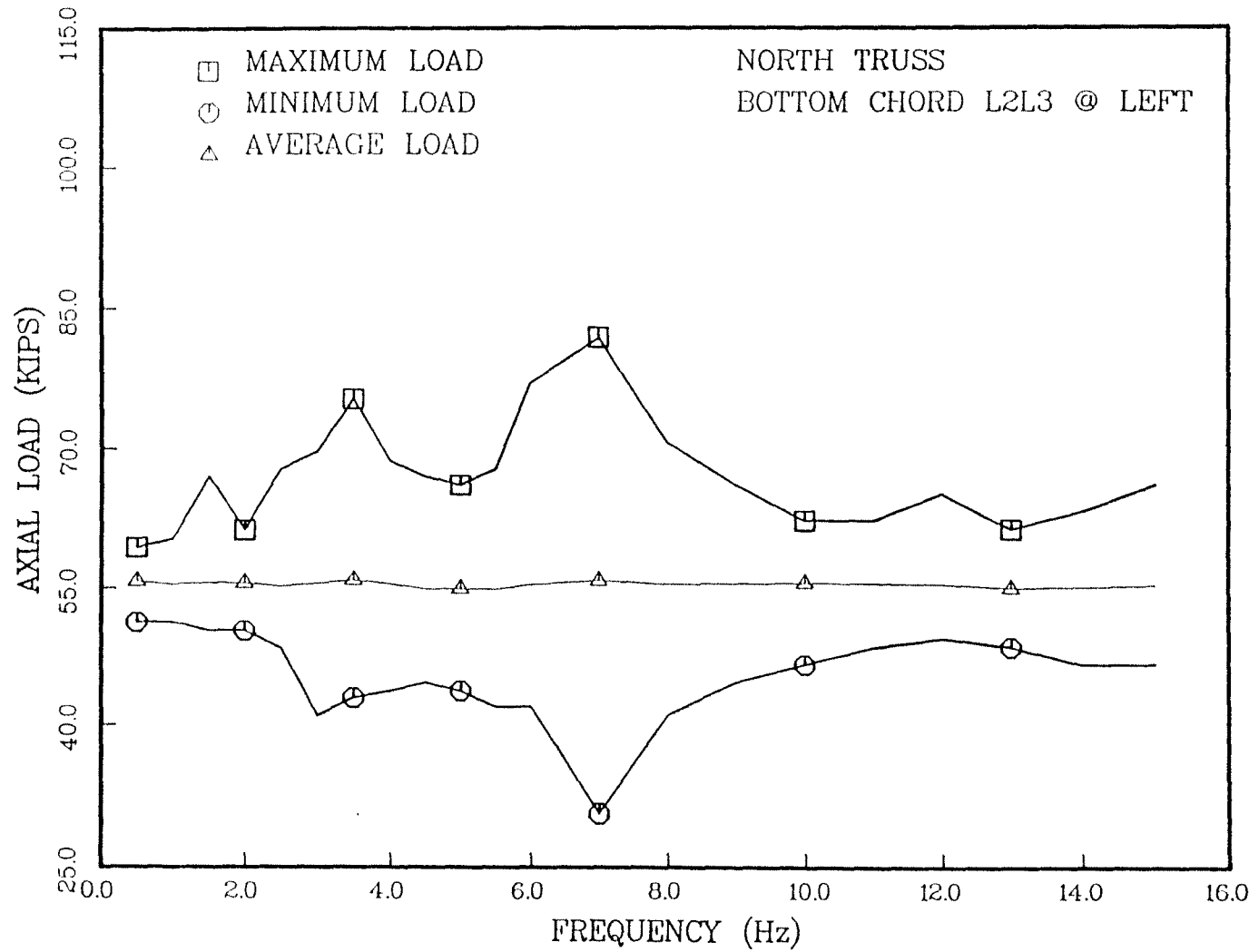

Exhibit D9. Resonance Curve of the Axial Force in West Bottom Chord L2L3 (Left End) of North Truss from the Results of the TLV Steady-State Sinusoidal Tests on the Bridge.

PROPERTY OF EPA
RESEARCH & DEVELOPMENT
LIBRARY

