

# Appendix B2:

## Basis of Design Report

# Long Bridge Project

## Basis of Design

### Technical Criteria for Conceptual Engineering

April 2019

# Basis of Design

## *Technical Criteria for Conceptual Engineering*

---

### Table of Contents

<b>1.0</b>	<b>Introduction.....</b>	<b>1</b>
1.1.	Definitions.....	2
1.2.	Concept Engineering Limits.....	4
1.3.	Project Approach .....	6
1.4.	Planning Considerations .....	6
1.4.1.	Operational Capacity.....	6
1.4.2.	National Environmental Policy Act .....	7
1.5.	Utilization of Standards.....	7
1.6.	Topographic Survey .....	7
1.7.	Constructability.....	8
<b>2.0</b>	<b>Railroad .....</b>	<b>9</b>
2.1.	Safety .....	9
2.2.	Design Codes, Manuals, Standards, Specifications, and regulatory Requirements .....	9
2.3.	Design Life.....	10
2.4.	Design Loading .....	10
2.5.	Design Speeds .....	11
2.6.	Horizontal Geometry .....	11
2.6.1.	Track Centers .....	11
2.6.2.	Tangent Alignment.....	12
2.6.3.	Horizontal Curve Alignment.....	13
	Superelevation .....	13
	Circular Curves .....	13
	Spiral Transition Curves .....	13
2.7.	Vertical Geometry.....	15
2.7.1.	Grades .....	15
2.7.2.	Vertical Curvature .....	16
2.8.	Clearances.....	16
2.8.1.	Bridges.....	18

- 2.9. Roadbed Section ..... 18
  - 2.9.1. Ballast Depth ..... 18
  - 2.9.2. Subballast Depth ..... 18
  - 2.9.3. Shoulder Width ..... 18
- 2.10. Special Trackwork ..... 19
  - 2.10.1. Speeds Through Turnouts and Crossovers..... 19
  - 2.10.2. Turnouts and Crossovers ..... 19
- 2.11. Track Gauge ..... 20
- 2.12. Rail..... 20
- 2.13. Rail Anchoring ..... 20
- 2.14. Tie Plates ..... 20
- 2.15. Ties ..... 20
  - 2.15.1. Concrete Ties..... 20
  - 2.15.2. Timber Ties..... 20
- 2.16. Signals and Communications ..... 21
- 3.0 Roadway ..... 22**
  - 3.1. Definitions..... 22
  - 3.2. Safety ..... 22
  - 3.3. Criteria..... 22
    - 3.3.1. Roadway Standards..... 22
    - 3.3.2. Design Content..... 22
    - 3.3.3. Pedestrian/Bike Paths/Trails..... 23
- 4.0 Drainage, Hydrology, and Hydraulics..... 24**
- 5.0 Bridges and Structures ..... 25**
- 6.0 Right-of-Way..... 26**
- 7.0 Utilities ..... 27**
- 8.0 Approvals and Design Exceptions..... 28**

## List of Tables

Table 1-1   Key Abbreviations .....	2
Table 2-1  Minimum Track Centers .....	11
Table 2-2   Minimum Tangent Length – Main Track .....	12
Table 2-3   Degree of Curvature .....	13
Table 2-4   Recommended Vertical Acceleration .....	15
Table 2-5   Minimum Clearances .....	16
Table 2-6   Track Item Depths .....	16
Table 2-7   Turnout Diverging Speeds .....	18
Table 2-8   Timber Ties .....	19

## List of Figures

Figure 1-1   Long Bridge Project Limits.....	4
Figure 2-1  Four Track Typical Section .....	11
Figure 2-2   Circular Curve with Spiral Transition .....	13

## Appendix

## 1.0 Introduction

The Long Bridge Project consists of potential improvements to the Long Bridge and related railroad infrastructure located between the Rosslyn (RO) Interlocking near Long Bridge Park in Arlington, Virginia and the L'Enfant (LE) Interlocking near 10<sup>th</sup> Street SW in Washington, DC (see **Figure 1-1**). The Long Bridge Corridor is currently owned and operated by CSX Transportation (CSXT), a Class I freight railroad. In addition to CSXT freight, the Corridor is utilized by Amtrak and the Virginia Railway Express (VRE).

As part of the project, a series of improvements along the 1.8-mile Corridor are evaluated to increase the current two-track capacity to four-tracks for use by both freight and passenger rail service. The proposed improvements along the Corridor include, but are not limited to, the following:

- Adding two new tracks adjacent the existing two-track alignment
- Adding a new two-track bridge upstream of the existing Long Bridge for a four-track crossing
- Retaining or replacing the existing two-track Long Bridge over the Potomac River
- Corridor-wide track upgrades to track, signal, and interlockings
- New and replacement bridges along the Corridor to achieve four-track capacity
- New retaining walls along the Corridor to minimize impacts and facilitate phasing

This Basis of Design (BOD) Report was prepared to document supporting technical criteria utilized for the refinement of Project's Phase II engineering concepts related to the railroad Corridor. Additional railroad capacity documentation was developed outside of the BOD to evaluate the implications of various stakeholder improvements on railroad capacity within the Project limits. Those stakeholders included CSXT, Amtrak, VRE, and the Virginia Department of Rail and Public Transportation (DRPT).

The BOD is applicable only to areas where new construction or major reconfiguration is anticipated to occur. Where major improvements are not required, existing tracks are exempt from the design criteria as well as the approvals and design exception process in Section 8 of this document. It is anticipated that portions of the existing track may need to be modified or upgraded for improved rail geometrics as well as to be included in modifications to the signal system.

The purpose of the BOD is to provide an overview of the technical criteria for Conceptual Engineering of the Long Bridge Corridor, with southern limits starting at the RO Interlocking and extending north to the L'Enfant Interlocking. The BOD has been closely coordinated and developed with input from the major project stakeholders, including the District Department of Transportation (DDOT); Federal Railroad Administration (FRA); DRPT; CSXT; Amtrak; and VRE. The Project Sponsor has yet to be identified for final design and construction and future infrastructure and corridor ownership; and maintenance responsibilities have also yet to be determined. Project stakeholders have agreed that all rail improvements will be conceptually designed consistent with CSXT design standards; FRA standards; and as described in the American Railway Engineering and Maintenance-of-Way Association (AREMA) Manual for Railway Engineering. Additional information on the proposed bridge over the Potomac River is provided in the *Long Bridge Project EIS Structures Study Report*.

Given the unknowns with future project ownership, this BOD is considered a living document that will be updated at the Preliminary Engineering phase based upon additional input and decisions made in project development.

### Long Bridge Project EIS

The primary goal of this version of the BOD is to provide sufficient technical criteria to complete conceptual design of the two Action Alternatives in support of the Environmental Impact Statement and selection of a Preferred Alternative. Once the Preferred Alternative is selected, the Preliminary Design will begin and include an update to the BOD.

## 1.1. Definitions

All definitions used in this document are in accordance with those used in AREMA MRE. Key abbreviations used for terms for this Project are identified in **Table 1-1**.

**Table 1-1 | Key Abbreviations**

<b>ABBREVIATION</b>	<b>DEFINITION</b>
<b>AAR</b>	<b>ASSOCIATION OF AMERICAN RAILROADS</b>
<b>AASHTO</b>	<b>AMERICAN ASSOCIATION OF STATE HIGHWAY TRANSPORTATION</b>
<b>AHJ</b>	<b>AUTHORITY HAVING JURISDICTION</b>
<b>AMTRAK</b>	<b>NATIONAL RAILROAD PASSENGER CORPORATION AND SUBSIDIARIES</b>
<b>AREMA</b>	<b>AMERICAN RAILWAY ENGINEERING AND MAINTENANCE-OF-WAY</b>
<b>BOD</b>	<b>BASIS OF DESIGN</b>
<b>CFA</b>	<b>COMMISSION OF FINE ARTS</b>
<b>CFS</b>	<b>CUBIC FEET PER SECOND</b>
<b>CSXT</b>	<b>CSX TRANSPORTATION</b>
<b>DC-SHPO</b>	<b>DISTRICT OF COLUMBIA STATE HISTORIC PRESERVATION OFFICE</b>
<b>DDOT</b>	<b>DISTRICT DEPARTMENT OF TRANSPORTATION</b>
<b>DRPT</b>	<b>VIRGINIA DEPARTMENT OF RAIL AND PUBLIC TRANSPORTATION</b>
<b>ES</b>	<b>ENGINEERING STATIONING</b>
<b>F/S</b>	<b>FEET PER SECOND</b>
<b>FHWA</b>	<b>FEDERAL HIGHWAY ADMINISTRATION</b>
<b>FRA</b>	<b>FEDERAL RAILROAD ADMINISTRATION</b>
<b>HEC-18</b>	<b>HYDRAULIC ENGINEERING CIRCULAR NO. 18</b>
<b>HEC-RAS</b>	<b>HYDROLOGIC ENGINEERING CENTER – RIVER ANALYSIS SYSTEM</b>
<b>HY-8</b>	<b>CULVERT HYDRAULICS ANALYSIS PROGRAM</b>
<b>MAS</b>	<b>MAXIMUM ALLOWABLE SPEED</b>
<b>MPH</b>	<b>MILES PER HOUR</b>
<b>MP</b>	<b>MILE POST</b>
<b>MRE</b>	<b>AREMA MCFS</b>
<b>MT-1, MT-2, MT-3</b>	<b>MAIN TRACK #1, #2 AND #3</b>
<b>MUTCD</b>	<b>MANUAL OF UNIFORM TRAFFIC CONTROL DEVICES</b>
<b>NCPC</b>	<b>NATIONAL CAPITAL PLANNING COMMISSION</b>
<b>NPS</b>	<b>NATIONAL PARK SERVICE</b>
<b>ROW</b>	<b>RIGHT-OF-WAY</b>
<b>SCC</b>	<b>VIRGINIA STATE CORPORATION COMMISSION, DIVISION OF UTILITY AND RAILROAD SAFETY</b>
<b>US-ACOE</b>	<b>UNITED STATES ARMY CORPS OF ENGINEERS</b>
<b>VDOT</b>	<b>VIRGINIA DEPARTMENT OF TRANSPORTATION</b>
<b>VRE</b>	<b>VIRGINIA RAILWAY EXPRESS</b>



## 1.2. Concept Engineering Limits

The Concept Engineering Limits extend approximately 1.8 miles within the RF&P Subdivision (previously the Richmond, Fredericksburg and Potomac Railroad) of the CSXT Baltimore Division (see **Figure 1-1**). The Preliminary Engineering Limits extend from L'Enfant (LE) Interlocking near milepost (MP) CPF 111.5 in the District of Columbia to the Rosslyn (RO) Interlocking at MP CPF 110.1 in Arlington, Virginia. The Concept Engineering Limits northern terminus adjoins the proposed station capacity improvements to the VRE L'Enfant Station; and the Concept Engineering Limits southern terminus in Arlington adjoins the northern limits of DRPT's Washington, D.C. to Richmond segment of the Southeast High-Speed Rail corridor (DC2RVA).

The Study Area is surrounded by diverse land uses between the District and Arlington County, Virginia, including local and national parks, residential mixed use, and commercial development. These land uses constrain the operational considerations. In general, the Project intent is to increase the number of tracks recommended by the capacity modeling over the Potomac River and into the District. Operational speeds will be maintained within the narrow railroad Corridor. The Concept Engineering Limits include multiple transportation structures. Capacity increases will impact the configuration of six (6) existing undergrade bridges and one existing overgrade viaduct within the Corridor:

- CSXT bridge over George Washington Memorial Parkway (Unknown)
- CSXT Long Bridge over Potomac River, Mount Vernon Trail, and Ohio Drive SW (DDOT Br #510)
- CSXT bridge over Ohio Drive SW (DDOT Br # 512)
- CSXT bridge over Interstate 395/695 (DDOT Br # 1135)
- CSXT bridge over Washington Channel (DDOT Br #513)
- CSXT bridge over Maine Avenue SW (DDOT Br # 514)
- Republic Properties Maryland Avenue SW viaduct over CSXT (Unknown)

In addition, there will be a new CSXT bridge over the WMATA Yellow Line Tunnel; the pedestrian bridge over Maine Avenue that connects the Mandarin hotel and the SW Riverfront will need to be replaced or reconfigured; new signal bridges will be incorporated along the Corridor; and retaining walls will be used throughout the Corridor.

Figure 1-1 | Long Bridge Project Limits



### **1.3. Project Approach**

The BOD Report documents the initial design standards applied to the engineering concepts. Additional criteria, definitions, and specifications are expected to be added during the development of the preliminary design, final design and construction documents. These modifications should be approved through a technical process based on sound engineering judgment, practice and economics. A general review process is described in Section 8.

Key Project development principles reflected in the BOD include the following:

- All mainline tracks will be designed to meet or exceed the maximum allowable speeds through the project area (25 mph minimum).
- All mainline tracks will be designed to meet or exceed the existing minimum vertical clearances at overhead bridges (Plate H clearance).
- On tracks to be owned and maintained by CSXT, mainline track centers shall meet or be wider than CSXT's standard track centers of 15 feet. Track centers less than 15 feet will require design exceptions and formal approval by CSXT.
- On tracks to be owned and maintained by CSXT, lateral clearances shall meet or be greater than CSXT's standards clearance of 18 feet. Lateral track distances less than 18 feet will require design exceptions and formal approval by CSXT.
- Preliminary design is not to preclude future electrification along the passenger tracks.
- Both new and existing mainline tracks shall be designed for resiliency, redundancy, interoperability, and connectivity between all passenger and freight service.
- Utilization of ongoing and previously completed studies, concept development, and rail improvement designs in the Corridor to the extent feasible and practicable.

### **1.4. Planning Considerations**

#### **1.4.1. Operational Capacity**

The Project objective is to provide additional long-term railroad capacity and to improve the reliability of railroad service through the Long Bridge Corridor. Capacity increases are needed to meet projected demand for passenger and freight rail services of stakeholders; improve operational flexibility and resiliency; and provide redundancy for this critical link in the local, regional, and national railroad network. To increase capacity, the 2-track Corridor is to be updated to 4-tracks through this project area. Capacity improvements were focused on obtaining one or more of the following objectives:

- Improved travel time;
- Increase and/or improve reliability and resiliency;
- Provide flexibility to recover during periods of higher demand and service delays, including track maintenance(resiliency);
- Increase in frequency of service;
- Increase in length of train/consistency; and
- Additional infrastructure to support improvements listed above.

### **1.4.2. National Environmental Policy Act**

The Long Bridge Project traverses through various historic areas, the viewshed of the Monumental Core of the District, private and federal properties, and environmentally sensitive areas. These features will require evaluation under the National Environmental Policy Act (NEPA) to avoid or mitigate the potential impacts. The evaluation must reflect the various influences the Project could have on these resources. Evaluation criteria will include, but is not limited to, the following considerations:

- Stakeholder, cooperating agencies, participating agencies, and public input on the various alternatives;
- Focus on minimizing impacts to adjacent private and federal properties;
- Focus on minimizing environmental impacts;
- Influences on visual view shed, noise mitigation, and aesthetic improvements;
- Improvements to railroad operational benefits and safety;
- Constructability of the proposed improvements; and
- Compatibility of proposed improvements with regional planning efforts.

### **1.5. Utilization of Standards**

The design will include the use of applicable agency standard drawings, materials, and specifications for applicable improvements within the Authority Having Jurisdiction (AHJ). The utilization of standard practices and materials promotes understanding of the intended improvements with the benefit of expediting the design and construction.

All new railroad equipment and track materials must conform to current and applicable CSXT standards or criteria (track owner/host railroad standards), AREMA guidelines, or approved industry standards. Roadway equipment and materials must conform to the appropriate AHJ: either Arlington County, National Park Service (NPS), DDOT, FHWA, Coast Guard, US-ACOE, DC-SHPO, or other impacted party. Refer to section 3.0 Roadway below for additional information.

### **1.6. Topographic Survey**

The Project covers topographic features in both the District and the Commonwealth of Virginia. The horizontal and vertical project control was established in accordance with the Maryland State Plane Coordinate System with a vertical datum based on NAD83.

The topographic survey was collected to identify the physical improvements and terrain features within the Project area. Topographic features were obtained from aerial mapping flown in July 2013 and December 2015 and field verified from publicly accessible points along the Corridor. Detail surveying of structural features (railroad bridges, roadway bridges, tunnels, and drainage culverts) were excluded until selection of the preferred alternative.

Topographic features were identified within a 150-foot boundary centered over the CSXT Corridor, extending from the southern limit of Four Mile Run (near MP CPF 108) in Virginia to the northern limit of the VRE L'Enfant Station (near MP CPF 112) in the District. These features include, but are not limited to, the track, retaining walls, railroad and roadway bridge superstructure outlines, vegetation, roadways, railroad signal equipment, and identifiable above and below grade utilities. Utilities shall be verified with

individual utility owners prior to construction. One-foot contours were developed from terrain elevations.

## 1.7. Constructability

Maintaining existing, or minimizing impacts to, roadway and railroad operations is required for making the infrastructure improvements. Lane restrictions for George Washington Memorial Parkway, I-395, Maine Avenue SW, Ohio Drive SW, and connecting side roads are to be limited to off-peak hours only for structural improvements. All roadway/lane closures will need to be coordinated and approved by their respective AHJ. MOT plans will also need to be approved by the AHJ.

Railroad operations, including both freight and passenger, are to be maintained during construction. Construction staging will include maintaining two operational tracks at all times to minimize delays to both freight and passenger services. Design development will require collaboration of staging and operation resources required of the host railroad, CSXT, and the passenger services utilizing the infrastructure. The following conditions are to be incorporated into the development of the construction staging for all existing and temporary tracks:

- The availability of track closures will be very limited and determined at the discretion of CSXT, working in cooperation with Amtrak and VRE. Track closures will be limited to the short off-peak service hours and on weekends and only when approved by CSXT, Amtrak, and VRE.
- Temporary track closures shall be scheduled and coordinated with CSXT, Amtrak, and VRE. Temporary track closures and the use of temporary tracks to maintain operations shall be considered on a case-by-case basis.
- Speed of temporary tracks shall be designed according to current CSXT timetable speeds or as approved by CSXT in coordination with Amtrak and VRE.

## 2.0 Railroad

Railroad geometric design is to be developed to provide safe, economical, and efficient freight and passenger service along the rail Corridor. The geometric design configurations must be developed to mutually maintain the operation and rolling stock stability for both freight and passenger operations.

The design criteria within the BOD reflects a combination of accepted and recommended engineering practices utilized by CSXT, Amtrak and VRE, as well as those contained in the AREMA Manual for Railway Engineering (MRE).

### 2.1. Safety

Safety of freight and passenger operations, freight and passenger employees, and the public above, under, and adjacent to the railroad Corridor represents the critical priority of the design. Railroad safety promotion and regulation is governed by FRA's Office of Railroad Safety, which includes FRA Track Safety Standards – 49 CFR Part 213. As the operator of the railroad Corridor, CSXT reserves the right to review and approve proposed railroad improvements.

The Long Bridge Project assumes that each alternative will maintain the existing posted speeds for freight and passenger trains along the existing railroad Corridor. If speeds are proposed to be increased by the Project due to improved geometry, FRA regulations require preparation of a system safety plan.

### 2.2. Design Codes, Manuals, Standards, Specifications, and regulatory Requirements

The design parameters for the conceptual design originated with the engineering and operating standards of CSXT. The following additional agency criteria was reviewed for more restrictive criteria or general compliance:

- AREMA Manual for Railway Engineering 2018 Edition
- Applicable FRA safety requirements
- Federal laws
- District of Columbia general laws
- Commonwealth of Virginia general laws

For preliminary and final design documents, the latest edition of the code, regulation, standard, and specification applicable to the Project in effect on the day of engineering Notice-to-Proceed (NTP) is applicable to the Project design. Revisions to code, regulation, standard and specification made during engineering design are to be presented to DDOT, CSXT, or the AHJ and approved prior to incorporating revisions.

This BOD is based on industry standards, governmental regulations, AREMA recommended practices, and railroad standards. The following publications and documents current references for Conceptual Engineering:

- CSXT Engineering and Operating Standards (in effect as of September 15, 2016)
- CSXT Public Projects Information Manual (Rev. July 2017)

- CSXT Design & Construction Standard Specifications – Pipeline Occupancies (Rev. June 5, 2018)
- CSXT Design & Construction Standard Specifications for the Design and Construction of Private Sidetracks (September 15, 2016)
- AREMA MRE 2018 Edition
- FRA Track and Rail and Infrastructure Integrity Compliance Manual (in effect as of January 2017)
- FRA Railroad Corridor Transportation Plans Guidelines (July 2005)
- D.C. Municipal Regulations, Chapter 24-31. OCCUPATIONAL SAFETY: RAILROAD CLEARANCES, Title 24. PUBLIC SPACE AND SAFETY.
- U.S. Code of Federal Regulations
- Absolute maximum/minimum values for any track design element shall comply with 49 CFR 213 for the applicable class of track. [On CSXT-owned and maintained track, CSXT will not allow any proposed track design element that does not comply with FRA class of track standards.]
- Strategic Rail Corridor Network (STRACNET) and Defense Connector Lines (December 1998) - <http://www.tea.army.mil/DODProg/RND/default.htm>

### **2.3. Design Life**

The design life for the new railroad related features and facilities are:

- Embankment: 50 years minimum
- Ballast and subballast: 10 years minimum
- Track structure (rail, ties, and fasteners): 35 years minimum
- Structures: 100 years minimum

It is anticipated that facilities will require regular maintenance and some degree of component repairs and replacement over the course of the design life. Additional decisions made on the preferred materials, fabrication, and installation of infrastructure will be made during the Final Design stage based upon Project Sponsor requirements.

Temporary facilities used to accommodate construction of permanent systems are to be designed for a period up to five years. Examples include temporary tracks and facilities during construction.

### **2.4. Design Loading**

The track system design is to be based on a Cooper E-90 loading for bridges intended primarily for CSXT freight operations in accordance with the CSXT Criteria for Ballast Deck Railroad Bridges. Bridges intended primarily for passenger operations will be based on Cooper E-80 loading in accordance with the AREMA MRE but the Maximum Rating will be checked for conformance to the E-90 loading specified by CSXT.

## 2.5. Design Speeds

The Corridor design speed is intended to maintain the existing freight and passenger speeds reflective of the existing topographic and environmental features constraints. The maximum allowable freight and passenger speeds are to be consistent with the host railroad timetable. In the likelihood of alternate alignments, FRA Class 3 track design speeds are the preferred minimum goal of the railroad Corridor. See Section 2.6 for additional design speed information at track turnouts and crossovers along the Corridor.

Horizontal curves are to be designed to the highest speeds possible for mixed traffic based on the design criteria, train performance models, and local conditions. Passenger train design speeds are to be established using the following procedure:

- Optimization of horizontal curve (reduce the degree of curvature)

## 2.6. Horizontal Geometry

On tracks to be owned and maintained by CSXT, track horizontal curvature and superelevation shall be designed to maximize speed for mixed traffic per CSXT standards. Mainline horizontal track alignments are to be stationed along the centerlines of the existing CSXT alignment. Engineering stationing (ES) increases from south to north. Station equations are to be used to correlate Project ES with Valuation Maps stationing, CSXT mileposts, and any identifiable bridges and relevant topographic or structures features referenced on the Valuation Maps.

All mainline tracks within proximity of the existing ROW are to be designed in accordance with the existing host railroad timetables. Engineering alternatives include meeting or matching the existing speeds throughout the Corridor, with alignments to be designed for a minimum speed of 30 mph for passenger operations and a minimum speed of 25 mph for freight operations. Existing sidings are to be assigned stations matching the mainline stations and station equations referencing the Valuation Maps.

### 2.6.1. Track Centers

Track centers (distance between the centerlines of two adjacent tracks) for mainline, lead tracks, tangent tracks, and tracks parallel to mainline tracks that are not being relocated or modified will remain at existing track centerline widths. On tracks to be owned and maintained by CSXT, mainline track centers shall meet or exceed CSXT's standard track centers of 15 feet. Track centers less than 15 feet will require design exception justification and formal approval by CSXT. The justification must include explanation of extenuating circumstance, limits of the standard deviation (exception), implications of not complying with the CSXT standard, and recommended infrastructure or installations to mitigate the impacts associated with the proposed exception. Corridor safety must be maintained in all circumstances, and in no case will track centers be reduced below their existing minimums in the same block of track.

District of Columbia Codes and Regulations specifies minimum track centers for use in the District, although the CSXT minimums are more restrictive. District limits may become relevant if CSXT grants exceptions to their standards. DDOT has an internal process for adjusting the DCMR requirements if needed as well through a separate design exception process. All other agencies that will issue permits and have jurisdiction for review and approval of the changes, including compliance to NEPA documents.



Virginia has no regulations affecting railroad track centers.

See **Table 2-1** for minimum track centers. Deviations from these values will be in accordance with Section 8.

**Table 2-1** | Minimum Track Centers

TRACK TYPE	CSXT MINIMUM	DCMR MINIMUM
<b>MAIN</b>	15'-0"	<b>14'-0"</b>
<b>OTHER TRACKS</b>	14'-0"	<b>14'-0"</b>
<b>CONGESTED YARDS</b>	N/A	<b>13'-6"</b>
<b>OTHER TRACK ADJACENT TO MAIN TRACKS</b>	<b>15'-0"</b>	<b>15'-0"</b>

The Long Bridge Project utilized the following typical sections for conceptual evaluation. Refer to CSXT Standard Drawing 2600 series for additional track configuration details (see **Appendix A**).

**Figure 2-1** | Four Track Typical Section

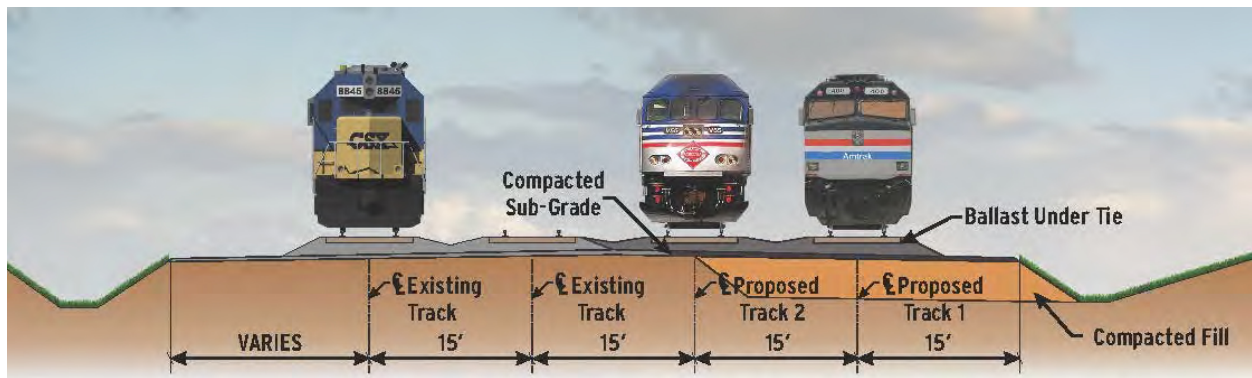

### 2.6.2. Tangent Alignment

In compliance with AREMA, the host railroads operating preference and passenger railway design best practices, the track geometry must maintain a minimum tangent length between designed track features. For mainline passenger tracks, the desired minimum tangent length (L) between curves can be determined by the following formula:

$$L = 3V$$

Where:

L = minimum tangent length, feet

V = freight design speed through the curve, feet per second

The tangent length formula is based on the rail car traveling at least two seconds on tangent track between two curves. The preferred and absolute minimum tangent track lengths are reflected in **Table 2-2** for predominate track circumstances. These minimums will be met unless a design exception is formally approved by stakeholders.

**Table 2-2 |** Minimum Tangent Length - Main Track

TANGENT LOCATION ON MAINLINE TRACKS	MINIMUM TANGENT	LENGTH (FEET)
	Preferred	Absolute
<b>BETWEEN CURVES</b>	3V	200
<b>BETWEEN POINT OF SWITCHES (PS) OF TURNOUTS (TOS)</b>	200	100
<b>BETWEEN PS AND CURVE</b>	200	100
<b>BETWEEN PS AND PLATFORM</b>	200	100
<b>BETWEEN PS AND GRADE CROSSING</b>	200	100
<b>BETWEEN PS AND BRIDGE</b>	500	100
<b>BETWEEN PS AND LAST LONG TIE OF TO</b>	200	100
<b>BETWEEN CURVE AND PLATFORM</b>	100	80
<b>BETWEEN CURVE AND GRADE CROSSING</b>	100	80

### 2.6.3. Horizontal Curve Alignment

#### Superelevation

Superelevation (sometime referred to as cant internationally), is defined as the algebraic height difference in profile elevations between the low rail (curve interior rail) and high rail (curve exterior rail) for a specific track. The height difference is used to counteract, or partially counteract, the lateral forces on a train through a horizontal curve. Additional benefits include distribution of load on the rails, improved ride quality for passenger comfort, and reduced asset wear on the rail and wheel. See CSXT’s Standard Drawings 2510 and 2511 for superelevation requirements.

#### Circular Curves

Circular curves will be defined by the chord definition of curvature. Track curvature will be compliant with the host railroad. Any existing curves will be improved to the extent possible within the constraints of the Corridor. Horizontal curvature will be adjusted between parallel tracks to accommodate additional horizontal clearance where possible.

Generally, turnouts will be placed outside of a horizontal curve in accordance with minimum tangent lengths. Single radius horizontal curves with transition spiral curves are preferred. The utilization of compound circular curves and circular curves joined by a transitional spiral will be minimized within the Project limits. Existing curves of these nature will be evaluated for the application of a single circular curve with transitional spiral curves.

#### Spiral Transition Curves

A clothoid spiral transition curve will be used on mainline tracks to connect tangents to circular curves. Curves associated with a turnout that connect the tangent from frog to a parallel track, or siding, are excluded from transitional spirals. Spirals will be designed to meet or exceed the existing spiral criteria,

spirals that do not meet CSXT’s requirements will require a design exception and formal approval from the host railroad.

The graphical configuration and components are reflected in **Figure 2-2** and **Table 2-3**.

**Figure 2-2** | Circular Curve with Spiral Transition

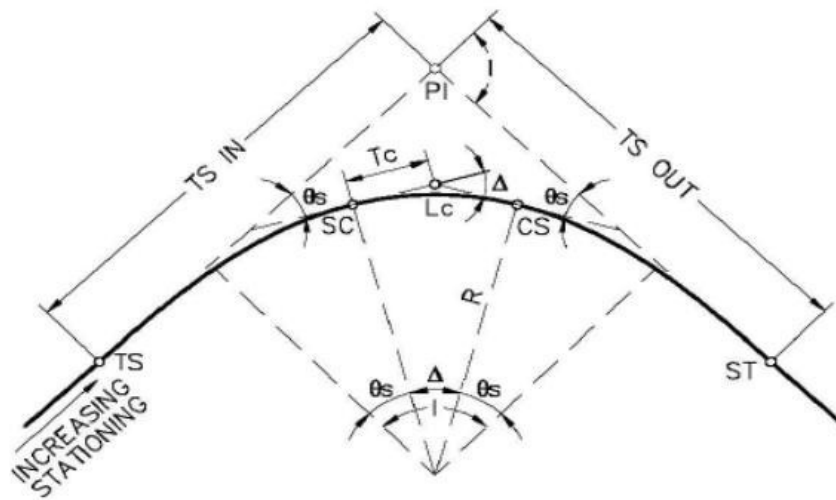

**Table 2-3** | Degree of Curvature

$D_c$	Degree of Curvature
$I$	Total Intersection Angle
$\theta_s$	Spiral Angle = $(L_s D_c) / 200$
$\Delta$	Central Angle of Circular Curve = $I - 2 \theta_s$
$R$	Radius of Circular Curve
$T_c$	Tangent Length of Circular Curve = $R \tan (\Delta / 2)$
$L_c$	Length of Circular Curve = $(\Delta / 180) R$
$L_s$	Length of Spiral
$TS$	Tangent to Spiral
$SC$	Spiral to Curve
$CS$	Curve to Spiral
$ST$	Spiral to Tangent

All mainline track will be configured with a length of spiral preferred by passenger services for passenger comfort. The length of spiral will be based on the desirable length of spiral stated in AREMA MRE Chapter 5, Section 3.1 formula, as the longest distance as determined from the following formulas:

1.  $L_s = 1.63E_uV$ ; or  $L_s = 1.22E_uV^*$
2.  $L_s = 1.2E_aV$

\* Spiral length  $L_s = 1.22E_uV$  requires approval in accordance with Chapter 5 of AREMA MRE.

Where:  $E_u$  = unbalanced superelevation  
 $E_a$  = actual superelevation applied to the curve, inches  
 $V$  = passenger train design speed, mph

The calculated length of spiral will require approval by the host railroad in accordance with Section 8. The desirable lengths of spiral will be reflected in 31 feet intervals.

For passenger train operations, the active total length of spiral in feet shall be defined by the following formula:

$$L_s = 1.46 Vt$$

Where  $V$  is the speed in mph;  $t$  is the time required to tilt (in seconds); and  $L_s$  is rounded to the nearest 100 feet (but not less than 100 feet).

Acknowledging the Project Corridor has a variety of constraints, including the availability of property, historic districts, monumental districts, environmental features, commercial development, and existing retaining walls, the absolute minimum length of spiral will be based on CSXT Plan 2511 and VRE and Amtrak Recommendations for passenger comfort (see **Appendix A**).

## 2.7. Vertical Geometry

Vertical geometry will be based on the top of the low rail. Track profile will reflect the existing rail elevation where possible. Due to the limitation of topographic information, the existing vertical alignments developed during concept engineering are reflective of the existing ground line without adjustments for rail height. These assumed alignments are to be revised with improved topographic survey information. Vertical elevations will be modified to obtain waterway and roadway clearances with all associated structural improvements.

Concept vertical geometry will be reflective of all tracks within the profile unless otherwise noted on the profile. Individual track profiles are to be developed during continued phases of the Project. Turnouts and switches are to be placed outside the limits of the vertical curve in accordance with minimum tangent lengths displayed in **Table 2-2**.

### 2.7.1. Grades

Track grades reflected with the vertical geometry will represent the effective grade of the track. All track grades will be evaluated in accordance with AREMA compensated gradients. The compensation factor will be 0.04 percent per horizontal degree of curvature. Compensated gradients are not to exceed 1.25 percent for new construction without formal approval and an accepted design exception from the host railroad. Any deviation shall be subject to review and acceptance of the operating railroad with a design exception process requirement.

For mainline track, the desired length of constant track grade between vertical curves will be the greater of either 100 feet or the result of the following formula:

$$L = 3V$$

Where: L = minimum tangent length, feet  
 V = freight design speed in the area, mph

### 2.7.2. Vertical Curvature

All changes in track grades will be connected with a parabolic curve in accordance with AREMA MRE, Chapter 5, Section 3.6. Mainline tracks will utilize the following equation for both crest and sag curves.

$$L = \frac{2.15(D \times V^2)}{A}$$

Where: L = length of vertical curve, feet (rounded up to the next 10 feet, minimum length of 100 feet)  
 D = Absolute value of the algebraic difference in rates of grades (expressed as a decimal)  
 V = Speed of freight train, mph  
 A = vertical acceleration, ft/sec/sec (ft/sec<sup>2</sup>)

The recommended vertical accelerations (A) for passenger and freight trains for both crest and sag curve are as follows (**Table 2-4**):

**Table 2-4 | Recommended Vertical Acceleration**

TRAIN TYPE	ACCELERATION (FT / SEC <sup>2</sup> )
<b>PASSENGER TRAIN</b>	0.60
<b>FREIGHT TRAIN</b>	0.10

The longest vertical curve length resulting from the vertical accelerations will be applied to the track profile. Vertical lengths will be rounded to the next 10 feet with a minimum length of 100 feet. Special track work must be in accordance with minimum tangent lengths displayed in **Table 2-2**.

## 2.8. Clearances

Railroad clearances refer to the recommended minimum separation between tracks in both a horizontal and vertical component. Horizontal clearances are references from the track centers to obstructions on either side of the track. Vertical clearances are referenced from the top of rail to the vertical obstruction. In track conditions with superelevation, the vertical clearance is referenced from the high rail.

Railroad clearance standards are defined by CSXT’s Standard Plans 2604 and 2605 (see **Appendix A**). These clearances are applicable to all new construction or design; including temporary construction or design.

On tracks to be owned and maintained by CSXT, the lateral or horizontal clearance (distance between the track centerline and closest horizontal obstruction) shall meet or be greater than CSXT’s standard

clearance of 18 feet. For obstructions that are buildings normally occupied by people or that support a bridge, the lateral track distance shall be 25 feet unless protected by a crash wall. Horizontal clearances must be shown from the centerline of track to the nearest obstruction if within 25 feet of the centerline of any track. Superelevation shall be taken into account when determining the horizontal clearance. New tracks with horizontal clearance less than 9 feet to any obstruction (other than buildings or bridge supports where it is 25 ft.) will require design exceptions and formal approval by CSXT. The justification must include explanation of the extenuating circumstance, limits of the standard deviation (exception), implications of not complying with the CSXT standard, and recommended infrastructure or installations to mitigate the impacts associated with the proposed exception.

DCMR, Title 24. Public Space and Safety, Chapter 24-31. Occupational Safety: Railroad Clearances specifies minimum clearances for use in the District although the CSXT minimums are more restrictive. District limits may become relevant if CSXT grants exceptions to their standards. Design criteria shall be satisfied to the approval of DDOT and the Federal Agency having jurisdiction. Virginia has no regulations affecting railroad clearances.

See **Table 2-5** for minimum clearances. Deviations from these values will be in accordance with Section 8 of this BOD.

**Table 2-5 |** Minimum Clearances

CLEARANCE TYPE	CSXT MINIMUM	DCMR
<b>LATERAL CLEARANCE, GENERAL</b>	<b>9'-0"</b>	<b>8'-0"</b>
<b>LATERAL CLEARANCE, PIERS AND ABUTMENTS, WITHOUT CRASH WALL</b>	<b>25'-0"</b>	<b>N/A</b>
<b>SIGNALS AND POLES</b>	<b>8'-6" minimum</b>	<b>10'-6" DESIRED</b>
<b>OVERHEAD</b>	<b>23'-0"</b>	<b>22'-0"</b>

Vertical roadway clearances are determined using the limited topographical information and track structure design assumptions, as well as design criteria per CSXT's *2017 Public Project Information Manual*. Any deviation from the standards will be subject to review and approval of a formal design exception. The track structure height is determined using the structure depths combined with the following criteria:

**Table 2-6 |** Track Item Depths

Track Item	Height (ft)
<b>Waterproofing and deck protection</b>	0.10
<b>Ballast</b>	1.00
<b>Conc. Tie + rail seat pad</b>	0.76
<b>Rail (136 RE)</b>	0.61

For new structures, vertical clearance from a horizontal plane at the top of the high rail to the nearest overhead obstruction shall have at least 24'-3" vertical clearance to accommodate potential future

electrification of the Corridor. Power lines shall be a minimum of 27'-0" above the plane of the top of rails and the distance shall be increased for higher voltages per the National Electrical Safety Code (NESC).

### **2.8.1. Bridges**

CSXT's *Public Projects Information Manual* provides the minimum requirements for overhead bridges. The manual establishes the expectations for maintaining safe and continuous passage of all rail traffic during and after bridge maintenance, rehabilitation or new construction. CSXT and the AHJ over the bridge have approval authority for construction plans, construction methodology, and clearance requirements.

In addition to CSXT requirements, the AHJ may have increased horizontal clearance requirements. The horizontal clearance of pier or abutments must meet or exceed the existing horizontal clearance with 25 feet from track centerline preferred. Clearances less than 25 will require a design exception. Structural features within 25 feet of track center must be protected with a crashwall compliant with AREMA MRE Chapter 8, Part 2, Section 2.1.5, VDOT Volume V, Part 2, File No. 06.06, or DDOT Design and Engineering Manual.

Structural inspections, bridge evaluations, and load ratings are conducted regularly by CSXT, VDOT, DDOT, and other bridge owners in accordance with federal and state requirements. Concept development and preliminary engineering for the Long Bridge Project are to be based on a review of existing bridge plans, inspection reports or information made available by the owner.

## **2.9. Roadbed Section**

Track roadbed criteria will be compliant with CSXT Plan 2601 (see **Appendix A**). The following general criteria is applicable to the track's roadbed section. Any discrepancy between criteria and standards shall be approved by DDOT, CSXT, and other federal and local agencies having jurisdictions and compliance to the NEPA documents.

### **2.9.1. Ballast Depth**

The ballast depth will extend not less than 12 inches below the lowest point of a timber or concrete tie to the track subballast for the full length of the tie and shoulders. Ballast depths are to increase proportionally for the full length of the tie in relationship to the track superelevation. All ballast materials are to be compliant with CSXT specifications and originate from a CSXT approved quarry.

### **2.9.2. Subballast Depth**

Subballast depth will be a minimum of 6 inches below the ballast on mainline tracks and sidings. Subballast is to conform with CSXT specifications and is not required on ballast deck bridges.

### **2.9.3. Shoulder Width**

Ballast shoulder width will extend beyond the end of the tie in accordance with CSXT Plan 2602 (see **Appendix A**).

## 2.10. Special Trackwork

Special trackwork refers to trackwork units that are used for tracks to converge, diverge, or cross each other through turnouts, and crossovers. On tracks to be owned and maintained by CSXT, all special trackwork will be designed according to CSXT standard drawings or to pre-approved standard CSXT supplier drawings.

### 2.10.1. Speeds Through Turnouts and Crossovers

On tracks to be owned and maintained by CSXT, passenger and freight speeds for turnouts and crossovers are governed by CSXT operating rules including CSXT signal aspects and current CSXT engineering standards. **Table 2-6** shows the speeds for the turnouts and crossovers that are expected as part of the Long Bridge Project. However, a speed less than those shown may be warranted based on the nearby track geometry and final railroad signal design and will be reevaluated by CSXT during the final design phase.

**Table 2-7 | Turnout Diverging Speeds**

TURNOUT DATA	SWITCH LENGTH & TYPE	PASSENGER (MPH)	FREIGHT (MPH)
#15	26'-0" Curved	30	30
#20	39'-0" CURVED	45	45

### 2.10.2. Turnouts and Crossovers

On tracks to be owned and maintained by CSXT, all turnouts and crossovers will be Nos. 15 or 20 according with CSXT standard drawings or pre-approved CSXT supplier drawings.

- All turnouts, including those within a crossover, are intended to be constructed of new 136-RE CWR and concrete ties. Turnouts incorporated into existing timber track or industrial sidings are to be constructed of new 136-RE CWR and timber ties. Turnout components, including switch points, stock rails, closure rails, guard rails, and frog wing rails are to be fabricated from new, high strength HH rail.
- 100 feet minimum from PS to the edge of road crossings (including sidewalks)
- 50 feet minimum from PS to Insulated Joint
- Crossovers are to be located in parallel tracks only
- Standard crossovers are preferred to be on 15-foot track centers

The application of non-standard turnouts and crossovers, such as equilateral turnouts, require approval in accordance with Section 8. The following situation may warrant non-standard turnouts and crossovers:

- Crossovers in non-parallel tracks
- Crossovers with track centers less than 15 feet
- Crossovers with track centers more than 25 feet



### 2.11. Track Gauge

The standard track gauge is 4 feet 8 1/2 inches. Track gauge is measured between the gauge sides of the heads of rails at 5/8 inch below the top of rails.

### 2.12. Rail

On tracks to be owned and maintained by CSXT, the rail section to be used will be new 136RE Continuous Welded Rail (CWR) per CSXT standards. Premium rail may be required according with CSXT engineering standards depending on final track geometry alignments, including curvature and expected traffic.

### 2.13. Rail Anchoring

Rail anchors are to be applied on conventional ballasted track construction utilizing timber ties, tie plates, and track spikes. Current CSXT standards establish the applicable details. Rail anchors are not used with concrete ties.

### 2.14. Tie Plates

On tracks to be owned and maintained by CSXT, tie plates and fasteners shall comply with CSXT standards, and be subject to CSXT approval.

### 2.15. Ties

#### 2.15.1. Concrete Ties

All new mainline track, turnouts, and crossovers construction is intended to utilize concrete ties. The following criteria is applicable:

- Concrete tie spacing is 20 inches, center of tie to center of tie, except as noted in CSXT Plans for special trackwork.
- Concrete ties are to be compliant with the type and material specification of CSXT.

#### 2.15.2. Timber Ties

The application of timber ties is at the discretion of CSXT. Timber ties are to be compliant with current CSXT standards and achieve the following criteria:

**Table 2-8 | Timber Tie Dimensions**

<b>Length</b>	8.5 feet
<b>Height</b>	7 inches
<b>Width</b>	9 inches

The maximum center of tie to center of tie spacing is 20 inches; the minimum is 18 inches.

## 2.16. Signals and Communications

The project delivery Contract will coordinate directly with CSXT to develop conceptual and preliminary signals and communications (S&C) designs and agreements. This separate design contract will run concurrently and share a similar timeline with the Long Bridge Project consultant team contract and work efforts. The consultant team will incorporate the S&C design information into the Long Bridge Project as appropriate and will coordinate directly with CSXT and DDOT throughout the Project.

On tracks to be owned and maintained by CSXT, CSXT will prepare preliminary and final S&C designs pursuant its existing system design standards, operating rules, and standard signal aspects. Signal route and aspect charts, including proposed design speeds, will be provided by CSXT for review by FRA.

## 3.0 Roadway

Roadway design are to be compliant with the AHJ. In Virginia, roadway designs are to comply with standard procedures, practices, and specifications of either Arlington County or VDOT. Within the District, roadway designs and approval are to be compliant with the procedures, practices and specifications of DDOT, FHWA, NPS, DOEE, DC-SHPO, the Commission of Fine Arts (CFA), and the National Capital Planning Commission (NCPC) and other agencies with approval authority.

### 3.1. Definitions

All definitions used in this document are in accordance with those used in DDOT, VDOT, FHWA, and AASHTO references.

### 3.2. Safety

Roadway design intentions are to provide a safe and reliable roadway infrastructure attaining the highest level of service within the physical and economical Project constraints. Design goals will be to apply the standard roadway design criteria. Designers are to provide justification for any physical, environmental, or economic constraints preventing standard criteria. Standard criteria deviations are to be collaborated with the AHJ, and approved by the AHJ, prior to implementing minimum criteria.

The host railroad (CSXT) reserves the rights to review, approve, deny, and/or issue a permit for all improvements either passing over or under the rail Corridor. Roadway designers are encouraged to be attentive to rail operation safety, traveling public safety, and the safety of the neighboring communities and commercial businesses.

### 3.3. Criteria

#### 3.3.1. Roadway Standards

Roadway designs are to be compliant with the AHJ. In situations with multiple design standards or policies, the more restrictive of the design criteria will be applicable. AHJ approval is required for alternate or “minimum” design criteria prior to application. In the absence of a design criteria standards, the designs are to be applicable to the *AASHTO Policy on Geometric Design of Highways and Streets, 6th Edition, 2011*.

#### 3.3.2. Design Content

The design content is to be compliant with the AHJ. The following roadway design elements are expected for all designs based on the design stage:

- Layout (Reflecting existing topographic features and proposed features)
- Right-of-way
- Typical Sections
- Traffic signing, lighting, and striping
- Horizontal and vertical alignments
- Vertical profile of primary roadway and relevant connecting roadways

- Drainage structures and networks
- Existing and proposed structural improvements (bridges and retaining walls)
- Utility conflicts/relocations
- Cross-sections (50-foot intervals and critical locations)
- Construction phasing and maintenance of traffic during construction

### 3.3.3. Pedestrian/Bike Paths/Trails

All bicycle/pedestrian paths/trails parallel to the rail Corridor are subject to the review and approval of the host railroad. A bicycle/pedestrian connection is being evaluated as a potential mitigation component of the Long Bridge Project and design criteria will be detailed separately from this Basis of Design.

In accordance with the CSXT *Public Projects Information Manual*, all bicycle/pedestrian paths/trails requiring to cross the Corridor are to be grade-separated. Crossing criteria will be compliant with the AHJ. Any barriers (including fences, wall, or other restrictive design options to prevent public access to the tracks) are to be located outside the host railroad ROW. Any deviations will come at the discretion of the host railroad.

## 4.0 Drainage, Hydrology, and Hydraulics

Drainage, hydrology, and hydraulic designs are expected to be developed at various Project phases, vary with required information, and be compliant with the AHJ. Designs developed during preliminary engineering are to be developed to an adequate level to effectively evaluate the impacts of the proposed improvements on the Potomac River, jurisdictional stormwater management requirements, ROW implications, and ascertain Project cost. Designs are expected to be completed during Final design and permitting phases to validate preliminary design assumptions and obtain the jurisdictional approval.

Hydrologic and hydraulic floodway analysis for the substructure requirements associated with Long Bridge are to be in compliance with 44 CFR 60.3(c)(10), unless state or local jurisdictions have a more stringent floodplain management criteria. All proposed improvements are expected to have no increase in the established FEMA floodplain boundaries.

Since the Long Bridge Project intends to utilize federal funds, the Project must comply with federal environmental requirements. In addition, drainage, hydrology, and hydraulic designs are expected to be compliant with any more restrictive requirements of the AHJ. Railroad drainage areas are to be designed in accordance with the host railroad's standards and specifications and/or AREMA MRE. Likewise, all other drainage areas are to be compliant with the applicable AHJ.

Railroad ditch dimensions will be compliant with CSXT Plan 2601 to the extent possible based on physical or environmental constraints. Culverts conveying water under the tracks are to be adequately designed to avoid impounding water at the inlet to avoid either impacts adjacent to properties or saturation of the track subballast based on a 100-year storm event. Drainage ditches and structures conveying railroad stormwater are preferred to be located within the host railroad ROW to facilitate maintenance.

For the Project, major drainage structures are considered as those structures equal to, or greater than, box culverts 6 feet by 6 feet or culverts greater than 6 feet in diameter. These structures are to be analyzed and sized during the preliminary engineering. All other structures are considered minor structures and represented on preliminary engineering plans. Minor structures are to be designed during the final design phase unless the structure is considered a significant contributor to the constructability of a designed portion of the Project.

## 5.0 Bridges and Structures

The Long Bridge Project contains a variety of structural features. These features include under-grade bridges, overhead bridges, tunnels, retaining walls, and major drainage structures. These structures will have multiple criteria from overlapping AHJ. In the situation of similar criteria, the more restrictive criteria will have precedence. Minimum horizontal and vertical clearance shall match or exceed existing conditions and will be discussed with each bridge and roadway owner prior to advancing conceptual engineering. Existing and proposed vertical clearances will be clearly defined on the conceptual engineering plans.

In general, all structures, including retaining walls, within the host railroad ROW are to be compliant with the practices of the host railroad (CSXT). Designs are to adhere to the requirements of the latest version of *CSXT Criteria for Overhead Bridges*, *CSXT Criteria for Ballast Deck Railroad Bridges*, and AREMA criteria. Overhead bridges for roadways and paths are subject to the applicable AHJ criteria. A risk-based design approach, including a cost-benefit relation analysis, shall be considered when selecting the appropriate seismic loading design criteria to be reviewed approved by the AHJ.

All structural construction phasing is to be based on maintaining train operations on two tracks and uninterrupted roadway circulation during construction. Temporary outage of tracks and roadway is permissible with approval from host railroad and AHJs, respectfully. Additional consideration shall be made to the existing foundations of the Long Bridge. Adequate separation is to be provided to construct a new bridge without influencing the existing bridges or tunnel per the *WMATA Adjacent Construction Project Manual*, including the existing WMATA Yellow Line bridge and tunnel.

Any new structures located over the Potomac River are subject to meeting the navigational requirements for the area set by the United States Coast Guard. Additional information provided in the *Long Bridge Project EIS Navigational Study*.

## 6.0 Right-of-Way

The graphical representation of the Right-of-Way (ROW) will be developed utilizing publicly available information and confirmed against the ROW information obtained from the Long Bridge Study Phase 1 Final report. Additional survey information in Arlington County, Virginia and within the District have also been obtained and surface contours developed for the surrounding Long Bridge Corridor. All survey information obtained will be used to verify the existing elevations and ROW information. The existing ROW limits will be obtained from the following sources:

- Washington DC Atlas and Recorder of Deeds GIS Database;
- DDOT ROW Section; and
- Department of Consumer and Regulatory Affairs Office of the DC Surveyor.

ROW impacts limits are to be evaluated based on the either proposed grading limits or structural features supporting the railroad and roadways. Permanent and limits of temporary easements that will be required for the construction access, phasing, staging areas, etc. are to be determined during the final design engineering phase.

## 7.0 Utilities

New or relocated utility crossings below the trackbed are subject to the review and approval of the host railroad, DDOT, NPS, FHWA, DC Water, and DC-DOEE. Identification of utilities shall be completed per ASCE Standard Guidelines for the Collection and Depiction of Existing Subsurface Utility Data (Level C); DC Water, DDOT, NPS, and FHWA utility guidelines and manuals. All designs are to be compliant with the latest versions of *CSXT Public Projects Information Manual*, *CSXT Design & Construction Standard Specifications for Pipeline Occupancies*, *CSXT Design & Construction Standard Specifications for Wireline Occupancies*, and Chapter 1, Part 5 of AREMA MRE. In addition to the standard practices and specifications of the utility service, the more conservative of the following practices are to be applicable unless approved otherwise by the host railroad:

- Use protective casing pipe for all utility line crossings beneath main line tracks;
- Casing pipe can be omitted for non-pressure sewer located in branch or industrial line tracks with approval of host railroad;
- Casing pipe and joints shall be leak proof and capable of withstanding a minimum railway load of Cooper E-90; or
- Steel casing shall have minimum yield strength of 35,000 PSI.



## 8.0 Approvals and Design Exceptions

The designer is expected to adhere to the practices and criteria specified in the BOD. DDOT and FRA recognize the potential for deviations to the technical criteria presented in the BOD. These deviations may be necessary for avoidance of environmental constraints and physical constraints. These changes must be approved by the AHJ prior to implementing the criteria change.

All design exceptions are to be submitted by the design team in writing to DDOT and FRA for distribution to the AHJ. Each variation request will be logged for tracking and distributed to the appropriate AHJ for consideration. Those stakeholders having jurisdiction will provide a written response to the variance request.

The designer is requested to provide adequate information for the exception. Adequate information includes, but is not limited to:

- Applicable BOD section;
- Implications of applying BOD criteria;
- Rationale and justification for the request and the location(s) and/or length where the exception may apply
- Benefits of exception;
- Graphical representation through plan/profile/typical section;
- Order-of-Magnitude cost estimate reflecting increases or savings;
- Identification of exception with regard to the minimum standard and its relevance to the desirable standard;
- Identification of effects of the exception to the freight and intercity passenger rail system operations and maintenance, if any, and appropriate potential mitigation measures;
- Supporting documentation, including a description of the specific design element and the applicable criteria; and
- Professional engineer signature and seal of the design engineer of record.
- Elements proposed to be constructed or installed to mitigate the risks associated with not constructing the items to applicable standards and that warrant a requested for an exception.

The AHJ reserves the right to request additional information to understand the implications of the variance.

## **APPENDIX:**

*CSXT Public Projects Information Manual (Rev. July 2017)*

*CSXT Design & Construction Standard Specifications – Pipeline Occupancies (Rev. June 5, 2018)*

*CSXT Design & Construction Standard Specifications for the Design and Construction of Private Sidetracks (September 15, 2016)*

*FRA Railroad Corridor Transportation Plans Guidelines (July 2005)*

*CSXT Standard Plans (2213-2218, 2224-2225, 2508, 2510-2511, 2516, 2521-2522, 2524, 2527, 2601-2605, 2611-2612)*

*CSXT MWI 703-07 Rail Anchoring Policy*

*CSXT Standard Clearances for Overhead Structures*

*WMATA Adjacent Construction Project Manual*



# Public Project Information

For Construction and  
Improvement Projects That  
May Involve the Railroad

*Prepared by the Public Projects Group  
CSX Transportation Inc.  
Jacksonville, Florida  
(last revised July 2017)*



# To the Communities, Businesses and Government Agencies

## We Serve:

CSX Corporation and its business units provide rail and intermodal service in 23 states, the District of Columbia and two Canadian provinces. CSXT operates more than 1,200 trains daily, over 21,000 miles of track, helping North America maintain the strongest and most productive transportation system in the world.

In addition to CSXT's vitally important customer service responsibilities, the company wants to be a good neighbor in the communities where we operate. That is why we have prepared this information. We want to make it easier for communities and other project sponsors to work with us when they have construction and improvement projects that may involve CSXT rail property.

CSXT's Public Projects team is involved in a wide variety of projects initiated by government agencies, local businesses and others. Accurate and timely communication of information between CSXT and these parties improves planning, relationships and successful completion of projects. The tools in this manual explain important steps project sponsors must follow, including information required in connection with any public project proposal.

CSXT places the highest priority on safety – for its employees and for the public. Because CSXT is a business and its shareholders ultimately own its rail system, the company must also give careful consideration to anything that could adversely affect customer service, compensation for use of railroad property, and risk to railroad operation.

The Project Managers – Public Projects are the initial contact for CSXT and are assigned territories by state. Please contact them directly about public projects using the information provided. General Engineering Consultants (GEC) provide additional engineering services to assist CSXT in managing public projects.

CSXT hopes the information and procedures provided here will make it easier for us to work together.

*Tony Bellamy*  
Director Project Management  
Public Projects

# CSXT Public Project Policy Information Table of Contents

<b>Topic</b>	<b>Page</b>	<b>Revised</b>
Information Covered in this Manual	3	7-19-17
CSXT Public Projects Staff and Territory Map	4	7-19-17
Additional CSXT Resources and Contacts	5	7-19-17
Definitions	6	7-19-17
Requirements for Preliminary Engineering Review	8	7-19-17
Payment of CSXT's Cost and Expenses	10	7-19-17
Insurance Requirements for Public Projects	11	7-19-17
Entry onto CSXT Property	13	7-19-17
Construction Monitoring Requirements	14	7-19-17
Railroad Flagging for Activities On or Near CSXT Property and Tracks	15	7-19-17
Highway-Rail Grade Crossing Surface Maintenance and Replacement	17	7-19-17
Alterations to Highway-Rail Grade Crossing Warning Devices	18	7-19-17
Overhead and Undergrade Bridge Projects	19	7-19-17
Parallel Road Construction	20	7-19-17
Painting and Cleaning CSXT Bridges to Improve Appearance	21	7-19-17
Cleaning and Painting of Bridges over CSXT	22	7-19-17
Public Road Crossing Openings and Closures	23	7-19-17
Bicycle/Pedestrian Pathways and Multi-Use Trails	25	7-19-17
Quiet Zone Proposals	26	7-19-17
<b>Appendix</b>		
Standard Preliminary Engineering Agreement	28	07-19-17
Standard Construction Agreement	33	07-19-17
Temporary Right of Entry Agreement	51	07-19-17
ROE and Indemnity Agreement for Bridge Painting (Aesthetic)	57	07-19-17
Special Provisions for Construction near CSXT Property	70	07-19-17
Overhead Bridge Criteria	74	07-19-17
Undergrade Bridge Criteria	80	07-19-17
Construction Submission Criteria	89	04-14-15
Drainage Criteria	98	09-09-14
Environmental Soil and Water Management Policy	105	07-19-17
Trail Construction Under CSXT Bridges	106	07-19-17

Additional information can be obtained by contacting the following:

- American Railway Engineering and Maintenance of Way Association,  
(301) 459-3200, or [www.arena.org](http://www.arena.org)
  
- U.S. Department of Transportation, Manual of Uniform Traffic Control Devices,  
<http://mutcd.fhwa.dot.gov/>

# Information Covered in This Manual

This information is intended to assist communities and other project sponsors to plan and implement construction and improvement projects that may involve the CSXT rail property. Examples of such projects include:

- **Highway-Rail Grade Crossings:** Closure, removal, installation and alterations of public highway-rail grade crossings. CSX's Real Estate and Facilities Management (REFM) department manages private crossings.
- **Bridges Over CSXT:** Construction, reconstruction, rehabilitation, repair, removal, and maintenance of bridges over the railroad by outside parties.
- **Bridges Carrying CSXT:** Construction, reconstruction, rehabilitation, repair, removal, and maintenance of bridges carrying CSXT over highways and other public properties initiated by outside parties.
- **Parallel Roads/Facilities:** Construction, reconstruction, modification, removal, and maintenance of parallel roads or other public facilities affecting CSXT property or operations.
- **U.S. Army Corps of Engineers Projects:** Any project undertaken by the Corps of Engineers that involves CSXT property or operations.
- **Entry Onto CSXT Property:** Temporary rights of entry onto CSXT property, easements, utility installation and bridge inspections.
- **Other Projects Involving CSXT Rail Corridors:** Publicly sponsored projects involving or altering CSXT facilities or its property. These projects may be on, above, adjacent to, or otherwise have the potential to impact CSXT property.

## **Important notes:**

***The information herein is intended to be a tool only and all statements in this manual are intended to be for broad use. This manual cannot be taken as authority to construct. Specific projects will be subject to analysis of all factors leading to formal agreements between all parties. The purpose of review by CSXT is solely to ensure compliance with the minimum standards of CSXT, and not for any other purpose.***

***The guidelines and requirements herein are provided for reference only and are subject to revision without notice. All new projects shall be designed in accordance with the most current policies, requirements, and standards of CSXT.***

***Any items affecting railroad property not covered in this manual shall be subject to CSXT's prior review and approval.***

***The safety of CSXT employees and the general public is of paramount importance to CSXT.***

# CSXT Public Projects Staff and Territory Map

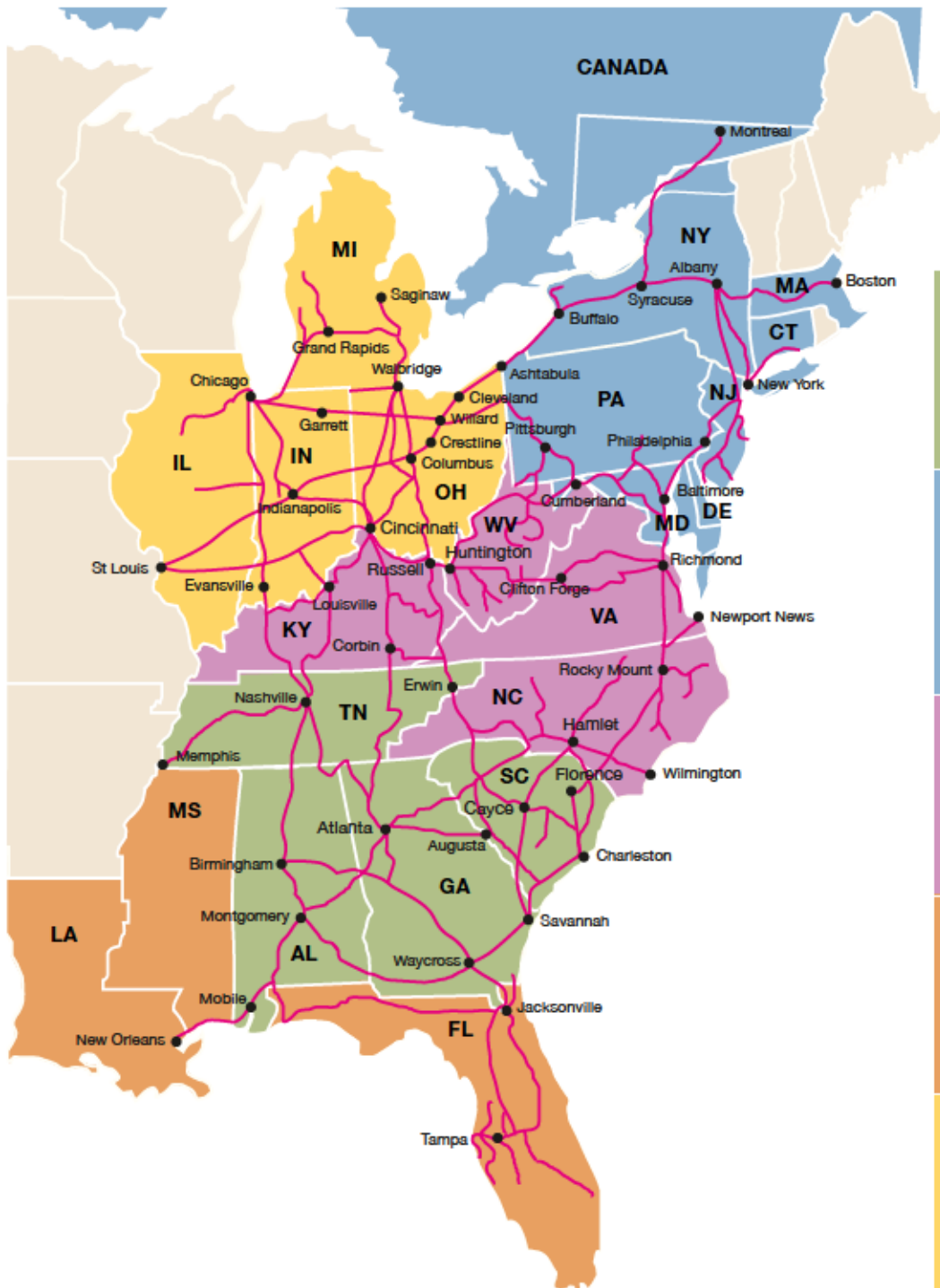

## **TN, AL, GA, SC**

Scott Willis  
500 Water Street, J-301  
Jacksonville, FL, 32202  
(904) 359-1405  
Scott\_Willis@csx.com

## **NY, PA, MA, NJ, CT, CANADA, MD, DE**

Derek S. Mihaly  
4 Neshaminy Interplex, Suite 205  
Trevose, PA 19053  
(215) 218-3391  
Derek\_Mihaly@csx.com

## **WV, VA, NC, KY, DC**

Troy J. Creasy  
1610 Forest Ave, Suite 120  
Richmond, VA 23229  
(804) 226-7718  
Troy\_Creasy@csx.com

## **FL, MS, LA**

Jacob Smith  
500 Water Street, J-301  
Jacksonville, FL 32202  
(904) 359-1650  
Jacob\_Smith@csx.com

## **MI, OH, IL, IN**

Amanda DeCesare  
500 Meijer Drive, Suite 305  
Florence, KY 41042  
(859) 372-6124  
Amanda\_DeCesare@csx.com

## **Director Project Management – Public Projects**

Tony C. Bellamy, P.E.  
500 Water Street, J-301  
Jacksonville, FL 32202  
(904) 359-7801  
Tony\_Bellamy@csx.com



## Additional CSXT Resources and Contacts

Many areas of community interest are outside the scope of this manual. The following is a list of contacts within CSXT that may be helpful on other community matters:

- **Emergencies:** Emergencies and suspicious situations should be reported immediately to the CSX Public Safety Coordination Center (800) 232-0144.
- **Corporate Communications and Public Affairs:** News media information, public affairs, state and community relations. Contact: (904) 366-2949.
- **Industrial Development:** New industry site locations, track proposals. Contact: Director Technical Programs, Regional Development (904) 359-1617.
- **CSX Real Estate and Facilities Management (REFM):** Non-Construction and Environmental right-of-entry, wire line and pipeline crossings, private crossings, compliance with codes relating to right-of-way conditions. Contact: <http://csx.com/index.cfm/customers/non-freight-services/propertyreal-estate/permitting-utility-installations-and-rights-of-entry/>
- **Quiet Zones:** Contact: [TellCSX@csx.com](mailto:TellCSX@csx.com)
- **Railroad Track and Signal Maintenance:** Non-emergency track maintenance, drainage maintenance, maintenance of highway-rail grade crossings surfaces and warning systems. Contact: [TellCSX@csx.com](mailto:TellCSX@csx.com)
- **Real Estate Lease or Purchase:** Contact: <https://www.csx.com/index.cfm/customers/value-added-services/property-real-estate/>
- **Structures and Bridges:** Maintenance of bridges that are CSXT's responsibility. Contact: Assistant Chief Engineer - Structures (904) 359-1104.
- **Passenger Operations:** Amtrak, passenger train proposals, commuter train proposals, light rail corridors. Contact: Director Passenger Services Strategy (904) 359-1099.
- **Rails to Trails:** Conversion of unused rail lines to trails. Contact: <https://www.csx.com/index.cfm/customers/value-added-services/property-real-estate/>
- **Non Emergency Issues:** Contact: [TellCSX@csx.com](mailto:TellCSX@csx.com)



# I. Definitions

1. *Agency* – The project sponsor (i.e., State DOT, Local Agencies, Private Developer, etc.)
2. *AREMA* – American Railway Engineering and Maintenance-of-Way Association – the North American railroad industry standards group. The use of this term shall be in specific reference to the AREMA Manual for Railway Engineering.
3. *Construction Submission* – The Agency or its representative shall submit six (6) sets of plans, supporting calculations, and detailed means and methods procedures for the specific proposed activity. All plans, specifications, and supporting calculations shall be signed/sealed by a Professional Engineer as defined below.
4. *Controlled Demolition* – Removal of an existing structure or subcomponents in a manner that positively prevents any debris or material from falling, impacting, or otherwise affecting CSXT employees, equipment or property. Provisions shall be made to ensure that there is no impairment of railroad operations or CSXT’s ability to access its property at all times.
5. *Contractor* – The Agency’s representative retained to perform the project work.
6. *Engineer* – CSXT Engineering Representative or a GEC authorized to act on the behalf of CSXT.
7. *Flagman* – A qualified CSXT employee with the sole responsibility to direct or restrict movement of trains, at or through a specific location, to provide protection for workers.
8. *GEC* – General Engineering Consultant who has been authorized to act on the behalf of CSXT. GECs perform preliminary engineering, construction inspection, and monitoring under the direction of the CSXT Engineering personnel. GEC personnel also perform day-to-day administration of certain types of projects.
9. *Horizontal Clearance* – Distance measured perpendicularly from centerline of any track to the nearest obstruction at any elevation between TOR and the maximum vertical clearance of the track.
10. *Professional Engineer* – An engineer who is licensed in State or Commonwealth in which the project is to occur. All plans, specifications, and supporting calculations shall be prepared by the Professional Engineer and shall bear his seal and signature.
11. *Potential to Encroach* – Work having the possibility of impacting CSXT property or operations; defined as one or more of the following:
  - a. Any activity where access onto CSXT property is required.
  - b. Any activity where work is being performed on CSXT ROW.
  - c. Any excavation work adjacent to CSXT tracks or facilities, within the Theoretical Railroad Live Load Influence Zone, or where the active earth pressure zone extends within the CSXT property limits.
  - d. The use of any equipment where, if tipped and laid flat in any direction (360 degrees) about its center pin, can encroach within twenty five feet (25’-0”) of the nearest track centerline. This is based upon the proposed location of the equipment during use, and may be a function of the equipment boom length. Note that hoisting equipment with the potential to foul must satisfy the 150% factor of safety requirement for lifting capacities.
  - e. Any work where the scatter of debris or other materials has the potential to encroach within twenty five feet (25’-0”) of the nearest track centerline.
  - f. Any work where significant vibration forces may be induced upon the track structure or existing structures located under, over, or adjacent to the track structure.
  - g. Any other work which poses the potential to disrupt rail operations, threaten the safety of railroad employees, or otherwise negatively impact railroad property, as determined by CSXT.
12. *ROW* – Right of Way; Refers to CSXT Right-of-Way as well as all CSXT property and facilities. This includes all aerial space within the property limits, and any underground facilities.

13. *Submission Review Period* – A minimum of 30 days will be required for the initial review response. Up to an additional 30 days may be required to review any/all subsequent submissions or resubmission.
14. *Theoretical Railroad Live Load Influence Zone* – A 1 horizontal to 1 vertical theoretical slope line starting at bottom corner of tie.
15. *TOR* – Top of Rail. This is the base point for clearance measurements. It refers to the crown (top) of the steel rail; the point where train wheels bear on the steel rails. Use the higher of the two rails when track is superelevated.
16. *Track Structure* – All load bearing elements which support the train. This includes, but is not limited to, the rail, ties, appurtenances, ballast, sub-ballast, embankment, retaining walls, and bridge structures.
17. *Vertical Clearance* – Distance measured from TOR to the lowest obstruction, within six feet (6'-0") of the track centerline, in either direction.



# Requirements for Preliminary Engineering Review

## Key Points

- **Starting CSXT Preliminary Engineering (PE) early by providing conceptual plans lowers project costs and shortens the time required for CSXT review and approval**
- **Using standard agreements lowers costs and saves time**
- **If the proposal requires easement CSXT Property Right, the project sponsor should provide the proper submittals to the GEC when beginning PE.**
- **If the proposal requires a utility encroachment, the project sponsor should contact CSX Real Estate and Facilities Management (REFM) when beginning PE.**
- **PE typically costs \$8,000 to \$25,000**
- **CSXT PE Review will not begin until the PE Agreement is fully executed and PE funds are received.**

## Overview

Any project proposals that may affect or be near the CSXT right-of-way must be evaluated by CSXT. To initiate a construction or improvement project, a PE agreement is required to identify the project sponsor, the scope, define the tasks to be accomplished, and specify the payment required. Once the plans for the project are approved by CSXT, a construction agreement will be developed.

## Purpose

The purpose of the PE is to identify issues related to safety, engineering, customer service, operations, legal and regulatory matters, expense, risk and other considerations specific to any proposed project. CSXT review of plans is only to determine that the plans, and improvements constructed in accordance with the plans, satisfy CSXT's requirements. Plans should be submitted early in project development to ensure that CSXT requirements can be incorporated.

## Process Steps To Be Taken

- Notify CSXT Public Projects Group of the project by providing location information and conceptual plans.
- Provide CSXT authorization to incur preliminary engineering costs.
- Review and complete a standard PE agreement and provide payment for expenses as specified in the agreement.
- Provide project information; attend meetings (as needed), review site with CSXT or GEC personnel.
- Submit initial plans to CSXT or designated GEC for review.
- Respond to CSXT or designated GEC comments and adjust design if necessary.
- Submit final design for CSXT or designated GEC review.
- CSXT will perform final review to ensure compliance with railroad requirements.
- CSXT will estimate the cost of the work to be done by CSXT, including flagging.
- If CSXT takes no exceptions to the design plans (or once all CSXT concerns have been addressed), CSXT will prepare a standard construction agreement for execution.

## Costs and Expenses

These matters are covered in more detail in the section that follows ("Payment of CSXT's Costs and Expenses"). For the reasons described in that section, CSXT requires advance payment for its costs and expenses of reviewing and handling the PE. All expenses of the party seeking the review will be borne by that party, including expenses for CSXT employees or GEC personnel attending meetings, reviewing plans, preparing correspondence and other activities to support the review of the project.

## Timing

It is in the interest of all parties to complete the PE review before commitments are made or construction steps begin. CSXT will work to be responsive, with timing depending upon the complexity of the project. CSXT and its GEC will work with the project sponsor to schedule PE and construction to meet project schedule objectives whenever possible, considering available resources.

# Requirements for Preliminary Engineering Review

## Property Rights

- Construction and improvement projects involving CSXT property will require a conveyance of property rights.

### FOR EXAMPLE:

- Highway-Rail Grade Crossings
- Bridges Over CSX
- Parallel Roads/Facilities
- Road/Bridge Widening Projects

Use these instructions as a guide to the real estate review process for property right conveyances.

- Simple Steps for Submission

1. Submit the following items to the GEC assigned to your location\*:

- Plan sheet calling out the easements areas and easement types (temporary, perpetual, aerial, etc.);
- Metes and bounds description for each easement area;
- Formal offer (include appraisal report if available);
- Cover letter with project scope.

\*Any missing information will result in a delay in processing

2. GEC forwards the submission to CSX Real Estate and Facilities Management (REFM)
3. Receive Receipt Confirmation Email from REFM
4. REFM Review: Location, Title, Appraisal
5. Deed Preparation
6. Closing - upon receipt of fully-executed construction agreement

## Standard Documents and Estimates

CSXT executes hundreds of agreements each year for preliminary engineering and construction of projects. CSXT has developed standard agreements which can be executed by CSXT without additional legal review. Non-standard agreements or modifications to the CSXT standard agreement terms will require additional legal review and may increase project duration and/or cost. Sample standard agreement documents are available in the Appendix. CSXT will begin each project with a PE estimate and PE agreement. After execution of the PE agreement and receipt of the PE deposit, CSXT will complete the PE phase of the project. At the end of the PE phase, CSXT will provide the project sponsor a construction estimate for all required CSXT costs during the construction phase of the project. CSXT provided estimates are valid for one year from date of approval noted on the estimate form.



# Payment of CSXT's Costs and Expenses

## Key Points and Procedures

- Preliminary Engineering (PE) costs are paid in advance.
- CSXT construction expenses will be estimated during PE and the estimate will be incorporated into the construction agreement. Advance payment is required to cover these expenses prior to the start of project construction.
- If CSXT anticipates that actual expenses will exceed the advance payment, additional payment will be required. Project work may be stopped until additional payment is received.
- If CSXT's actual expenses are less than the sum of any deposits the difference will be refunded after final cost accounting.
- All funding sources must be identified up front, and any time funding sources change, CSXT must be immediately informed. CSXT requires the completion of a "New Project Funding Form" at the beginning of each project. By completion of this form, the project sponsor agrees to reimburse CSXT for project related costs. Each time project funding changes, a new "New Project Funding Form" must be completed.

## Overview

The types of projects being addressed in this manual usually do not directly benefit and, in some cases, create risk to, and hurdles for, CSXT's core business of providing transportation service vital to its customers and the American economy. For these reasons, CSXT seeks payment for its costs and expenses incurred in connection with project review or construction.

## Examples of Costs and Expenses

Agency shall reimburse CSXT for all costs and expenses incurred by CSXT in connection with the Project, including, without limitation:

- All out of pocket expenses
- Travel and lodging expenses
- Telephone, facsimile, and mailing expenses
- Costs for equipment, tools, materials and supplies
- Sums paid to CSXT's consultants and subcontractors
- CSXT labor in connection with the Project (included but not limited to flagging), together with CSXT labor overhead percentages established by CSXT pursuant to applicable law
- For estimating purposes only, typical flagging costs are \$1,300 per day.



# Insurance Requirements for Public Projects

## I. Insurance Policies:

Agency and Contractor, if and to the extent that either is performing work on or about CSXT's property, shall procure and maintain the following insurance policies:

1. Commercial General Liability coverage at their sole cost and expense with limits of not less than \$5,000,000 in combined single limits for bodily injury and/or property damage per occurrence, and such policies shall name CSXT as an additional named insured. The policy shall include endorsement ISO CG 24 17 evidencing that coverage is provided for work within 50 feet of a railroad. If such endorsement is not included, railroad protective liability insurance must be provided as described in item 4 below.
2. Statutory Worker's Compensation and Employers Liability Insurance with limits of not less than \$1,000,000, which insurance must contain a waiver of subrogation against CSXT and its affiliates (if permitted by state law).
3. Commercial automobile liability insurance with limits of not less than \$1,000,000 combined single limit for bodily injury and/or property damage per occurrence, and such policies shall name CSXT as an additional named insured. The policy shall include endorsement ISO CA 20 70 evidencing that coverage is provided for work within 50 feet of a railroad. If such endorsement is not included, railroad protective liability insurance must be provided as described in item 4 below.
4. Railroad protective liability insurance with limits of not less than \$5,000,000 combined single limit for bodily injury and/or property damage per occurrence and an aggregate annual limit of \$10,000,000, which insurance shall satisfy the following additional requirements:
  - a. The Railroad Protective Insurance Policy must be on the ISO/RIMA Form of Railroad Protective Insurance - Insurance Services Office (ISO) Form CG 00 35.
  - b. CSX Transportation must be the named insured on the Railroad Protective Insurance Policy.
  - c. Name and Address of Contractor and Agency must appear on the Declarations page.
  - d. Description of operations must appear on the Declarations page and must match the Project description.
  - e. Authorized endorsements must include the Pollution Exclusion Amendment - CG 28 31, unless using form CG 00 35 version 96 and later.
  - f. Authorized endorsements may include:
    - (i). Broad Form Nuclear Exclusion - IL 00 21
    - (ii). 30-day Advance Notice of Non-renewal or cancellation
    - (iii). Required State Cancellation Endorsement
    - (iv). Quick Reference or Index - CL/IL 240
  - g. Authorized endorsements may not include:
    - (i). A Pollution Exclusion Endorsement except CG 28 31
    - (ii). A Punitive or Exemplary Damages Exclusion
    - (iii). A "Common Policy Conditions" Endorsement
    - (iv). Any endorsement that is not named in Section 4 (e) or (f) above.
    - (v). Policies that contain any type of deductible

5. All insurance companies must be A. M. Best rated A- and Class VII or better.
6. The CSX OP number or CSX contract number, as applicable, must appear on each Declarations page and/or certificates of insurance.
7. Such additional or different insurance as CSXT may require.

## **II. Additional Terms**

1. Contractor must submit the original Railroad Protective Liability policy, Certificates of Insurance and all notices and correspondence regarding the insurance policies to:

Insurance Department  
CSX Transportation, Inc.  
500 Water Street, C-907  
Jacksonville, FL 32202

[insurancedocuments@csx.com](mailto:insurancedocuments@csx.com)

2. Neither Agency nor Contractor may begin work on the Project until it has received CSXT's written approval of the required insurance.

*Insurance Requirements Document updated June 2017*



# Entry onto CSXT Property

## Key Points

**Written permission is required for all parties entering CSXT property.**

- **Construction Agreements authorize entry onto CSXT property.**
- **Temporary right-of-entry agreements can also be used for limited purposes.**
- **CSX Real Estate and Facilities Management (REFM) handles temporary rights of entry for non-construction activities.**
- **CSXT Public Projects handles temporary rights of entry for construction activities.**
- **All parties must adhere to CSXT Safety procedures.**
- **Appropriate insurance is required.**

## Overview

To maintain efficient customer service and to ensure the safety of CSX employees and of those parties requesting access to CSXT property, CSXT requires all parties accessing its right-of-way for investigative activities or for the performance of construction work to have a written agreement with CSXT fully detailing each party's responsibilities. Activities by others with the potential to affect CSXT's property, operations, and or personnel without actually entering CSXT property must also be reviewed with CSXT and appropriate arrangements and agreements completed.

The process by which an appropriate agreement covering entry and/or the other necessary conditions or requirements can be developed and implemented is typically dependent upon the scope of the activities proposed by an outside party or agency. Although the type of agreement may vary, most agreements include insurance and liability provisions, work procedures and conditions and reimbursement provisions relating to payment to CSXT for costs it may incur in relation to the entry or work. The following summarizes the various types of CSXT agreements and contracts most frequently utilized to accommodate the requested entry and the proposed work activities.

### Entry for Construction Work via CSX Real Estate and Facilities Management (REFM)

Entry for construction work (not exclusively associated with utility work) will require a Construction Agreement or a Temporary Right-of-Entry Agreement, as determined by the magnitude of potential impacts to CSXT.

A Construction Agreement will be required for construction work that could impact CSXT facilities or operation, such as construction or rehabilitation of a bridge over CSXT, roadway construction or other highway improvements, or grading and/or drainage work.

Construction work that will not impact CSXT facilities or operation may be handled by a Temporary Right-of-Entry Agreement, as determined by CSXT Public Projects.

### Entry for Non-Construction Work via CSX Real Estate and Facilities Management (REFM)

A Temporary Right-of-Entry agreement is utilized by CSXT primarily in situations where outside parties or agencies desire to undertake investigative work such as performing survey work, taking borings, performing bridge inspections or undertaking other activities requiring only access to CSXT property and not construction work activities. Different agreements are used for temporary private crossings.

Applications for Temporary Right-of-Entry agreements for investigative and non-construction work activities (including movement of off-highway or oversized loads at grade crossings) within CSXT's right-of-way can be obtained by contacting CSX Real Estate and Facilities Management (REFM) at [www.csx.com](http://www.csx.com). Click on "Community – Property and Projects," and then click on "Learn more" under "Utility installations and Rights of Entry."

### Entry For Other Purposes via CSX Real Estate and Facilities Management (REFM)

CSXT may use other forms of agreements covering entry by outside parties or agencies depending on work scope or other factors. The process to obtain right of entry for these purposes as listed below may also be initiated through CSX Real Estate and Facilities Management (REFM) at <https://www.csx.com/index.cfm/customers/value-added-services/property-real-estate/permitting-utility-installations-and-rights-of-entry/>

- Environmental Right-of-Entry
- Utility Permit/License Agreement for pipeline and wire line construction – both for specifications and applications
- Land Lease applications
- Movement of oversized loads across CSXT tracks at private or public highway-rail grade crossings
- Movement of off highway construction equipment across CSXT tracks at private or public highway-rail grade crossings





# Construction Monitoring Requirements

## Key Points

- **Construction work affecting CSXT will be monitored by CSXT and its consultants at the project sponsor's expense.**
- **Construction monitoring is in addition to flagging and other protective services.**

## Overview

To ensure the safety of the public and CSXT employees, maintain quality rail service to CSXT customers and to protect CSXT assets, CSXT may require construction monitoring (in addition to flagging protection) of the project. The construction monitoring will be conducted by CSXT and its consultants at project expense.

## General Guidelines

Construction monitoring includes intermittent or continuous on-site presence of CSXT or its consultants during construction activities.

- The construction project sponsor, owner, or agency in charge will pay for the cost of construction monitoring. Construction monitoring will be specified, and the estimated cost will be included in the construction agreement for the project.
- Construction monitoring is in addition to railroad-approved flagging.
- Construction monitoring includes CSXT review and approval of all plan changes and required contractor submissions during the construction phase of the project.
- The project sponsor is responsible for its safety and the safety of its property, contractors, and employees. CSXT, as part of its construction monitoring, will review the work site for activities that could interfere with safe operation of the railroad.
- CSXT and its consultants are not responsible for monitoring the general work activities under the direction of the project sponsor for compliance with safety regulation. Any observed unsafe acts or conditions will be reported immediately to the project sponsor or contractor representative.



# Railroad Flagging for Activities On or Near CSXT Property and Tracks

## Key Points

- **Flagging services are required when projects are within close proximity to active rail lines, as required by federal law.**
- **Flagging services can only be performed by personnel qualified by CSXT.**
- **Arrangements for flagging services may take up to 90 days to schedule.**

## Overview

In the interest of public safety and the safety of employees and property, CSXT will work cooperatively with agencies, consultants, contractors and others who need to access railroad property when work brings them in close proximity to active railroad tracks to determine the appropriate flagging services needed and to make arrangements for those services.

## Conditions When CSXT Flagging Services Are Required:

- When any entity is working on, near or adjacent to active railroad tracks.
- When an outside party is using railroad property or performing operations that may affect railroad property or facilities. This includes occasions when a party has been given express permission from CSXT to enter railroad property or perform such operations under the terms of a Construction agreement, Temporary Right-of-Entry agreement or other appropriate documentation.
- When work off railroad property has the potential to impact CSXT property or operations.
- When off-highway construction equipment is crossing the railroad at a private or public crossing.
- When oversized equipment or highway vehicles are to cross the railroad at a private or public crossing.
- In other instances as determined by CSXT.

## Qualified Flagging Personnel

CSXT flagging services may only be performed by personnel qualified by CSXT who are trained in the proper procedures related to rail operations and safety requirements, familiar with rail operations and procedures in a project area and able to communicate directly with CSXT dispatching personnel and train crews.

## Arrangements for CSXT Flagging Services

- CSXT will make arrangements for flagging services related to planned work by an outside party under the terms of a temporary right-of-entry agreement, construction agreement, environmental license agreement or other mutually acceptable arrangements.
- Advance notice must be provided to secure CSXT flagging services. The level of advance notice may vary from site to site or project to project or if CSXT determines, under the provisions of its labor agreements with its union forces, that flagging services can only be provided as a result of the flagging position being bid and awarded to qualified CSXT personnel.
- Advance notice must be provided to cancel CSXT flagging services. If advance notice to cancel is not provided, the project sponsor will be responsible for paying for the flagging until CSXT is notified. Requests to cancel or end flagging should be given at least 3 days in advance.

## Responsibility for Costs and Expenses

- All costs and expenses associated with CSXT flagging services are the sole responsibility of the agency, consultant or contractor.
- CSXT will provide its estimated costs prior to the start of the project work or its assignment of flagging personnel.
- Once flagging personnel are formally assigned by CSXT to a specific work location, the period of assignment can only be changed with appropriate advanced arrangements.
- Charges for providing flagging services beyond a normal eight-hour weekday are calculated and billed at an overtime rate.
- For initial planning purposes, typical flagging cost is \$1,300 per day.

## Examples of Flagging Costs and Expenses

Charges billed by CSXT to the agency, consultant or contractor may include, but are not limited to:

- Employee Salary
  - Hourly employee charges are based on the time an employee departs and returns to his or her headquarters location. As such, the charges can be expected to exceed the level actually incurred during the assigned coverage period or while the flagman is present at the specific work location.
  - This period also includes the time required for flagging personnel to perform the required preparations and termination procedures associated with flagging services at a location.
- Overhead Costs
  - These charges are assessed against the hourly employee charges and determined in accordance with standard accounting procedures or as mandated by State and/or Federal regulations.
- Employee Expenses or Per Diem Rate
  - This amount is calculated based on an employee's actual expenses or on a per diem rate according to the terms of applicable collective bargaining agreements between CSXT and its assigned union flagging employees.
  - The amount includes travel and lodging expenses and the cost for a leased, rented, CSXT, or personal vehicle to be used for transportation.
- Administrative, Accounting, and Billing Services
  - This amount is related to the time associated with setting up the agreement, arranging for and supervising the employee, billing and collection of costs, and other expenses associated with CSXT providing flagging services.
- Contracted Construction Inspection Services
  - CSXT may elect to use a contracted construction inspector in lieu of, or in addition to, a CSXT employee flagman.



# Highway-Rail Grade Crossing Surface Maintenance and Replacement

## Key Points

- Report issues with crossing surfaces to **TellCSX (TellCSX@csx.com)**
- **Coordination is required for work near crossings.**
- **Highways must be closed to vehicular traffic for crossing replacement or maintenance work.**
- **Agreements with CSXT are required for crossing work and work near crossings.**
- **Crossing surface maintenance and replacement must be performed by CSXT.**
- **Crossing surfaces must meet criteria set by CSXT's Engineering Standards. For identification purposes, each crossing has a distinct DOT inventory number (such as 123456A) posted at the crossing and the railroad milepost.**

## Overview

The crossing surface provides a path for highway vehicles to cross railroad tracks. The objective is to provide a safe, smooth, and cost effective crossing for highway and railroad traffic. Highway and railroad maintenance work in the vicinity of highway-rail grade crossings must consider safety concerns for both highway and railroad traffic before, during, and after the time the work is implemented.

## Identification of the crossing and location

Each crossing has a unique DOT inventory identification number posted at the crossing. There is often more than one crossing on the same road. The crossing number (such as 123456A) must be used to identify the specific crossing in all communications with the railroad to reduce possible confusion about the specific location.

## Crossing Construction

Railroad track is continuous through the crossing and includes railroad ties, rail and fasteners below the surface of the crossing. The crossing surface for highway traffic can be made of several different materials. Drainage is required for all four quadrants at a crossing.

## Crossing Surface Types and Selection

Crossing surface material and construction methods are selected for each crossing based on the type of highway and railroad traffic, past experience and funding available from highway agencies for individual projects.

Standard types of CSXT approved crossing surfaces are Concrete or Timber/Asphalt. Projects funded by outside parties may be constructed with other materials if specified by the outside party and approved by CSXT. Modular Platform "Tub" type crossings may be considered for use at locations with slow rail operations of 15 MPH or less and high road vehicle count and/or heavy vehicles.

## Crossing Maintenance and Replacement

Crossing maintenance and replacement of the track and crossing surface are performed by CSXT and may be billable to an outside party or highway authority as specified in an agreement. The responsibility for the maintenance of public crossing approach pavement varies by state and is specified in some individual crossing agreements or orders.

Crossing work requires closing the entire highway-rail grade crossing. Replacement of track components through a crossing requires removal of the crossing surface, replacement of track ballast, and surfacing the track through the crossing prior to replacement of the crossing surface. If the subgrade needs to be improved, the application of a hot mixed asphalt underlayment should be considered. Drainage will be reestablished for all four quadrants. After the crossing surface is replaced, the highway approach paving is completed and then the road is opened to highway traffic. Replacement of the track and crossing surface usually requires that the highway be closed for several days.

Crossing surfaces are also removed and replaced when track maintenance work is performed through a crossing such as rail replacement, tie replacement, and track surfacing (smoothing). Each crossing has the surface removed and replaced after the work has been completed. Crossings are usually closed for several days during this maintenance work.

## Requesting Crossing Surface Replacement or Upgrades

Highway agencies seeking replacement of crossing surfaces should contact CSXT Public Projects. The request for the work and the recommended surface must be reviewed and approved by CSXT. If approved, Public Projects will prepare a standard agreement and include the cost estimate for the project.



# Alterations to Highway-Rail Grade Crossing Warning Devices

## Key Points

- Any alterations to highway-rail grade crossing warning systems must adhere to all applicable laws, regulations and national standards.
- Requests to CSXT for new or modified public at-grade crossing warning devices must be initiated by the highway agency.
- Preliminary Engineering agreements are used to define the project scope and prepare design and estimate information for each project.
- The requesting project sponsor will be responsible for advance payment for engineering, design and installation of warning devices.
- The coordination of traffic intersection signals with warning devices will be determined by the highway agency or regulatory agency.
- Construction agreements are used to implement the projects.

## Overview

The Public Projects Group will process all projects proposing alterations to public highway-rail grade crossing warning systems. Included will be projects for opening new crossings, closing existing crossings, modifying or widening of existing crossings, installing new warning systems, removing and/or relocating existing warning systems and modifying/upgrading existing warning systems.

## Identification of the crossing and location

Each crossing has a unique DOT inventory identification number posted at the crossing. There is often more than one crossing on the same road. The number (such as 123456A) must be used to identify the specific crossing in all communications with the railroad to reduce possible confusion about the specific location.

## Design Considerations

Highway-rail grade crossing warning systems must adhere to all applicable Federal and State standards and regulations, and local policies, laws and ordinances, as well as CSXT standards. The highway agency, not CSXT, is responsible for determining the level and configuration of warning devices for a public highway-rail grade crossing. In addition, the highway agency or other governmental agency responsible for making warning system and equipment determinations is responsible for selecting appropriate vehicular traffic control signs and/or devices for a specific public highway. Loop Detection Circuitry will not be designed, installed, owned, or maintained by CSXT.

Recommended practices and additional information are available in American Railway Engineering and Maintenance of Way Association (AREMA) manuals and the Manual on Uniform Traffic Control Devices (MUTCD).

## Engineering, Cost Estimation, Installation

CSXT will provide engineering, design, and cost estimates for the installation of highway-rail grade crossing warning devices at the expense of the project sponsor as part of the Preliminary Engineering for a project. Changes to highway-rail grade crossing surfaces may also require engineering and estimating by CSXT. Because of labor agreements with CSXT's union forces, CSXT will install the highway-rail grade crossing warning devices.

## Operation of Highway-Rail Grade Crossing Warning Devices

Highway-rail grade crossing warning systems are designed to activate in advance of a train entering the crossing. Train speed changes while approaching the crossing may cause the warning system to activate longer than expected. Trains stopping or making forward and reverse movements near the crossing may cause the warning system to activate and then clear after an appropriate time without a train entering the crossing.

## Traffic Light Preemption Interconnection

The highway agency will determine if preemption is required. Preemption of the cycle of traffic signals at highway intersections near highway-rail grade crossings requires careful review by highway traffic engineers to determine the appropriate timing and sequence for both the traffic signal and the highway-rail grade crossing warning system. Preemption for the traffic signal may be simultaneous with, or in advance of, the warning system activation. The appropriate sequence and timing shall be provided by the highway agency and distributed to CSXT to facilitate CSXT's signal design. CSXT will furnish one preemption interconnection circuit of a normally closed contact that is designed to open upon the approach or presence of a train and will terminate the closed preemption interconnection circuit in a common cable junction box to be used for the interconnection of the traffic signals and the grade crossing warning devices.



# Overhead and Undergrade Bridge Projects

## Key Points

- Overhead and undergrade bridge projects must comply with CSXT's policies and standards, which are available in the appendices of this manual.
- All work on overhead and undergrade bridges must be reviewed and approved by CSXT.
- CSXT should be involved early in the project development phases to allow required bridge standards to be incorporated into the design of the project.
- A preliminary engineering agreement and construction agreement will be required.
- CSXT property and operations (including train speeds) shall not be negatively impacted by the project.
- No temporary reduced clearances will be permitted.
- CSXT requires that new overhead bridges (including existing bridge replacements) span CSXT's right-of-way and have a minimum 23' vertical clearance above top of rail.
- All new undergrade bridges must have a ballast deck.
- MSE walls are prohibited on CSXT property.
- Vehicular Clearance signage for clearance under CSXT bridges is the responsibility of the road authority, not CSXT.

## Overview

Given the efficiencies and environmental benefits of moving goods by rail, CSXT continues to see strong demand for rail services across its network. It is critical that CSXT maintain the ability to expand its network in the future.

CSXT requires that new overhead bridges (including existing bridge replacements) span CSXT's right-of-way and have a minimum 23' vertical clearance above top of rail. CSXT requires that new undergrade bridges provide accommodations for future operating needs, as determined by CSXT.

During project construction, rail operations must not be impeded. Temporary run-around track(s) and/or phased construction may be necessary as determined by CSXT.

## General Guidelines

- All bridge projects over or under CSXT shall be governed by the appropriate criteria found in the appendices. This includes but is not limited to replacements, new construction, substructure modifications and/or repairs, superstructure replacement or repair, and deck replacement or overlay.
- Temporary and final drainage plans must be approved by CSXT.
- CSXT's access to its property must be maintained.
- Plans must show all tracks and horizontal and vertical track clearances for both the existing conditions and the proposed project.
- Bridge demolition criteria are found in the Overhead Bridge Criteria in the appendices of this manual.
- Upon completion of construction, a full set of as-built drawings, showing actual measured vertical and horizontal clearances, shall be furnished to CSXT.



# Parallel Road Construction

## Key Points

- **Proposed parallel public roads shall be located off CSXT property.**
- **Safety at existing highway-rail grade crossings must be considered and not adversely impacted.**
- **No additional drainage may be directed onto railroad property.**
- **CSXT's access to its property must not be impeded.**
- **Construction may result in the need for alterations to crossing warning systems or facilities.**

## Overview

In the interest of public safety, parallel public roads shall be located off CSXT property. Parallel roads involving intersections with existing or proposed highways where public or private crossings are present should be aligned to provide sufficient distance from the crossing for the largest vehicle (design vehicle) permitted to use the road to stop between the railroad and the parallel road traffic control signs, markings, and warning devices without interfering with railroad operations, obstructing or preventing the operation of traffic control devices or obstructing the crossing in any manner.

## General Guidelines

The design of highways, highway intersection, and configuration of highway-rail grade crossings is the responsibility of the highway agency. Drainage for highway runoff, the railroad corridor, and adjacent property must be designed to reduce or maintain existing railroad drainage and to prevent standing water and potential erosion. Access for CSXT equipment to the railroad property, structures, and track cannot be restricted or prevented.

Federal and State design manuals, the Manual of Uniform Traffic Control Devices (MUTCD) and additional recommended practices available in American Railway Engineering and Maintenance of Way Association manuals (AREMA) provide design information to be considered by the highway agency responsible for the project engineering. The table of contents of this document has additional information on the MUTCD and AREMA manuals and information.



# Painting and Cleaning CSXT Bridges to Improve Appearance

## Key Points

- **CSXT understands the desire of communities to improve the appearance of bridges and other structures. Safety of CSXT employees, the general public and neighbors restrict some alternatives for bridge appearance improvement.**
- **CSXT may permit others to paint CSXT bridges if labor agreement, technical and responsibility requirements are resolved.**
- **Any surface preparation methods must follow all applicable environmental guidelines and must be approved in advance by CSXT.**
- **CSXT will not accept proposals to attach signage to CSXT bridges.**
- **A written request should be submitted to CSXT's Public Projects Group to initiate consideration of such projects.**

## Overview

Requests are occasionally made by outside parties for various beautification projects, including painting of overhead and undergrade bridges. These requests are considered on a case-by-case basis by CSXT. The cost of painting and future aesthetic maintenance will be the responsibility of the project sponsor proposing to paint the CSXT bridge. CSXT will make every effort to cooperate, consistent with maintaining the safety of the public and the safe operation of the railroad.

## Consideration of Bridge Painting Projects

Bridge painting proposals must be reviewed and approved by CSXT to ensure compliance with safety and environmental regulations, CSXT specifications, and to ensure that the proposal will not impact CSXT's property or operations.

- CSXT will require an agreement for all bridge painting proposals.
- A public agency must be a party to the agreement.
- CSXT will incur no costs or liabilities as a result of the project.
- The public agency or its designee will be responsible for maintenance of the painted surfaces, including aesthetic damage caused by highway vehicles and vandalism.
- A railroad flagman will be required at the project expense.

## Submission of Project Requests

A written request by the party wishing to undertake such projects should be forwarded to CSXT's Public Projects Group for handling. The request should include information about the situation and the project objectives to assist CSXT with completion of the review. The following information should be included:

- The project sponsor and public agency that will execute appropriate agreements for implementation as well as future maintenance of the painted surfaces.
  - Paint specifications that meet CSXT standards and methods for surface preparation, cleanup, and paint application.
  - Qualifications and experience of the painting contractor. CSXT will accept state qualified bridge painting contractors working for the responsible agency or company. Containment system, clean up and disposal of all paint and other material removed from the bridge. The clean-up and disposal of material from the surface preparation for painting and actual painting must comply with all appropriate regulations.
  - The materials removed during the surface preparation must not impact the surrounding area including ground, water, or air. Materials must not be stored on CSXT property.
  - Control of paint overspray and vapors during application. The work must be done complying with appropriate regulations and over spray controlled to prevent damage to adjacent property and vehicles in the area.
  - Containment system, clean up and disposal of all paint and other material removed from the bridge. The clean-up and disposal of material from the surface preparation for painting and actual painting must comply with all appropriate regulations.
  - Pictures and conceptual drawing should be submitted with the initial request from the community to simplify the initial review and comment by CSXT.
  - Work site safety plan including keeping all personnel away from the tracks and fall protection measures where required.
- **Additional specifications are included in the Appendix titled "Aesthetic Bridge Paint Specifications."**  
■ **Important environmental information is included in the Appendix titled "Soil and Water Management Policy."**





# Cleaning and Painting of Bridges over CSXT

## Key Points

- **CSXT understands that maintenance of bridges over CSXT may include cleaning and painting. The safety of CSXT employees, the general public, and the project sponsor's contractors is of paramount importance to CSXT.**
- **A written request should be submitted to CSXT's Public Projects Group to initiate this type of project. The request will be reviewed for safety considerations and compliance with CSXT engineering and environmental standards.**
- **An agreement is required to accommodate engineering, review of plans, flagging, right-of-entry, and payment of CSXT incurred costs.**

## Overview

All work over CSXT has the potential to impact CSXT property and rail operations. CSXT will review bridge painting and cleaning projects to ensure environmental and engineering standards are met. This review, flagging protection and construction monitoring costs will be paid by the project sponsor.

## Requirements for Initiating and Implementing Bridge Cleaning and Painting

A Preliminary Engineering agreement is required to cover CSXT's review of the project and preparation of a cost estimate and construction agreement.

To ensure safety, a railroad employee flagman must be present to control railroad operations in the area during the planned work.

A written request by the party wishing to undertake such projects should be forwarded to CSXT's Public Projects Group for handling. The request should include information about the location and the project objectives to assist CSXT with completion of the review. The following information should be included:

- The project sponsor and appropriate public agency that will execute appropriate agreements for implementation as well as future maintenance of the painted surfaces.
  - Qualifications and experience of the painting contractor. CSXT will accept state qualified bridge painting contractors working for the responsible agency or company.
  - Containment system, clean up and disposal of all paint and other material removed from the bridge. The clean-up and disposal of material from the surface preparation for painting and actual painting must comply with all appropriate regulations.
  - The materials removed during the surface preparation must not impact the surrounding area including ground, water, or air. Materials must not be stored on CSXT property.
  - Control of paint overspray and vapors during application. The work must be done complying with appropriate regulations and over spray controlled to prevent damage to adjacent property and vehicles in the area.
  - Pictures and conceptual drawing should be submitted with the initial request from the community to simplify the initial review and comment by CSXT.
  - Work site safety plan including keeping all personnel away from the tracks and fall protection measures where required.
- **Important environmental information is included in the Appendix titled "Soil and Water Management Policy."**



# Public Road Crossing Openings and Closures

## Key Points

- Both federal and state government policies discourage the creation of new highway-rail grade crossings. To enhance highway-rail grade crossing safety, CSXT endorses the United States Department of Transportation's goal of reducing the number of at-grade crossings through consolidation, elimination, grade separation and restriction of the number of new crossings installed.
- Grade separated structures are the best alternative to add new roads or additional highway capacity.
- CSXT and state and federal agencies have worked with many communities to develop and implement projects that improve highway traffic flow without the creation of new highway-rail grade crossings.
- CSXT, the Federal Railroad Administration (FRA), and state agencies encourage communities to consider all alternatives before planning to create new grade crossings and encourage closure of existing grade crossings where possible.
- CSXT may provide incentive payments for crossing closures.
- To comply with and in support of the federal initiative to reduce crossings, CSXT requires the community to identify three comparable active grade crossings to be closed for each new grade crossing.
- New crossings, if approved, shall be maintained at the appropriate agency's expense.

## Overview

CSXT understands the importance of highway-rail grade crossings and their relevance to such priorities as economic development, emergency vehicle access and other growth opportunities in the communities through which we operate. Because of the safety concerns associated with highway-rail grade crossings, however, every effort must be made to obtain alternative access or additional capacity using grade separations, or by other roads leading to existing crossings.

## Crossing Closure Incentive Program

Eliminating crossings is a goal of CSXT, states and the Federal Railroad Administration (FRA). Likewise, the Federal Highway Administration (FHWA) Railroad-Highway Grade Crossing Handbook acknowledges that the first alternative that should always be considered for a highway-rail at-grade crossing is elimination. Elimination of a crossing provides the highest level of crossing safety because the point of intersection between highway and railroad is removed. Closing adjacent crossings simplifies the design, installation and operation of highway-rail grade crossing warning systems. To help ensure the success of this effort, CSXT may provide incentive payments for the closure of public crossings.

## Considerations for Crossing Openings and Closures

The addition of any grade crossing brings the potential for incidents involving trains and motor vehicles. For this reason, both federal and state government policies discourage the creation of new grade crossings. CSXT, other railroads, the United States Department of Transportation and most states encourage communities to carefully consider all alternatives, including grade separations (crossings that go over or under railroad tracks), as opposed to the creation of new at-grade crossings. The cost of a grade separation should not outweigh the enhanced safety it would provide for motorists.

CSXT, the FRA and other railroads actively participate in programs such as Operation Lifesaver, an initiative dedicated to educating the public on the importance of practicing safe driving procedures at grade crossings. For more information about crossing safety, visit: <http://www.beyondourrails.org/safety>

Before agreeing to the establishment of a new crossing, CSXT expects communities to engage in a study with the purpose of identifying existing redundant public crossings for closure. To comply with and in support of the federal initiative to reduce grade crossings, CSXT requires that the community identify the closure of three or more comparable active public at-grade crossings.

As discussed above, the appropriate public authority will be expected to reimburse CSXT for its cost of design, installation and future maintenance of the crossing.

## Policies and Procedures to Guide New Crossing Requests:

The project sponsor requesting a new crossing or seeking to convert a private crossing to a public crossing will be asked to prepare a written request, presenting the following information:

1. A description of the proposed highway project, including proposed passive or active traffic control devices, and the need for preemption and/or interconnection with traffic signals, together with a scale drawing or sketch of the proposed highway and vicinity.
2. Expected Annual Average Daily Traffic (AADT) and proposed vehicular speed limit, photographs, aerial map.
3. A detailed explanation of the necessity of the crossing.
4. Identify at-grade crossings to be closed. Include their vehicular speed limit, AADT, and traffic type.
5. The determination by the highway or regulatory authority of the need for passive or active traffic control devices and other safety treatments (i.e., signage, roadway medians, etc.), as selected by the highway authority consistent with applicable federal and state MUTCD guidelines and requirements.
6. A plan to satisfy any appropriate regulatory authority's requirements, procedures and approval. The project sponsor should coordinate with all applicable agencies (state, county, city, etc.) to ensure proper procedures are followed.
7. Provide CSXT authorization to incur costs for its Preliminary Engineering to review the crossing request (whether or not is approved), design and construction expenses, and for the ongoing maintenance of the crossing surface and related grade crossing warning devices.

CSXT will review the request for a new crossing and inform the project sponsor whether or not the new crossing is approved. CSXT may deny a new crossing request due to safety or operational concerns.



# Bicycle/Pedestrian Pathways and Multi-Use Trails

## Key Points

- Private or public parallel bicycle/pedestrian pathways and trails are not permitted on CSXT property.
- CSXT prefers grade separated bicycle/pedestrian pathways and multi-use trails.
- Bicycle/pedestrian pathways and trails cannot cross tracks at grade outside of existing highway easements.
- Pedestrian safety is enhanced when pathways and sidewalks are designed such that they cross the tracks at as close to a right angle as practical.
- The highway agency's design must include additional safety measures for at-grade pathways and trails within existing highway easements. These measures should include detectable warnings. Pathways and trails greater than 5' in width require either physical requirements or traffic control devices.
- CSXT will oppose condemnation proceedings aimed at recreational use of trackside property.
- New crossings, if approved, shall be maintained at the appropriate agency's expense.

## Overview

CSXT recognizes that communities often wish to establish recreational pathways and trails in the proximity of active railroad lines. While CSXT will work with communities to accommodate such requests, it is critical for project sponsors to recognize that CSXT requirements must be met and safety precautions taken to protect the public and CSXT employees. In addition, certain requests, such as pathway crossings at grade outside of existing highway easements, will not be permitted.

## CSXT Policy on Pathways and Trails Parallel to CSXT Property

At CSXT safety is paramount. CSXT's policy is not to permit private or public parallel bicycle/pedestrian paths that come within the railroad's right-of-way. CSXT will insist upon safety measures such as fencing and signage where such pathways or parks are established parallel to the railroad's right-of-way. The cost of installing, inspection and future maintenance are the responsibility of the trail sponsor or agency. CSXT will oppose any attempt to establish recreational usage of CSXT property through condemnation. Regardless of construction of pathways and trails, CSXT reserves the right to use CSXT right of way for operational necessities.

## Pathways and Trails Crossing CSXT Tracks and Right-of-Way

Bicycle/pedestrian pathways and trails cannot cross tracks at grade outside of existing highway easements. Grade separated pathway and trail crossings are preferred in all cases, and required when outside of an existing highway easement. Pathways and trails under existing railroad structures are discouraged and will only be allowed under special circumstances. Pathways and trails under existing railroad structures will require a canopy. The canopy shall allow CSXT to inspect, maintain, or repair its structure and shall not be attached to the CSXT structure. Please refer to the Trail Construction Under CSXT Bridges, for additional information (located in appendices to this document). Pathways and trails over and under the railroad track shall have protective fencing.

Bicycle/pedestrian pathways and trails crossing at-grade within a highway easement must have appropriate signs and warning systems as determined by the responsible highway and/or regulatory agency. When designing new sidewalk grade crossings, placing the sidewalk outside of the area occupied by grade crossing traffic control devices for vehicular traffic is important. This includes making sure that the counterweights and support arms for the automatic gates for vehicular traffic do not obstruct the sidewalk when the gate is fully lowered.

All expenses associated with the design, installation and maintenance of the pathway/trail, including the costs of signs, crossing surfaces and warning systems associated with an at-grade crossing, will be paid by the project sponsor.

Chapter 8 Section D of the Manual of Uniform Traffic Control Devices (MUTCD) provides design information to be considered by the highway agency responsible for the project engineering. The table of contents of this document has additional information on the MUTCD manual.

CSXT prosecutes trespassers and every precaution must be taken to ensure that the public remains clear of CSXT's property.



# Quiet Zone Proposals

## Key Points

- This section was developed as a guideline for communities that approach CSXT in regards to the implementation of a Quiet Zone under the Federal Railroad Administration's (FRA) final rule on the use of locomotive horns at public highway-rail grade crossings (49 CFR Part 222, the "Rule"), and to ensure CSXT's full compliance and cooperation with respect to the Rule.
- According to the FRA, the implementation of Quiet Zones – without appropriate safeguards and equipment – increases the risk of accidents at highway-rail grade crossings. In this context, CSXT encourages communities considering whether to pursue the implementation of a Quiet Zone to take into account the installation of appropriate Supplemental Safety Measures ("SSMs"), as defined in the Rule, as well as the consolidation and/or closing of adjacent crossings, all of which will act as a safeguard to potentially reduce the risk of accidents at each crossing below the risk level that existed prior to the implementation of the Quiet Zone.
- Communities that wish to implement Quiet Zones will be required to strictly comply with the Rule.
- Pursuant to the Rule, notifications and/or applications to implement or continue Quiet Zones are to be made to the FRA and must involve all relevant state and local agencies, CSXT, and any other rail carriers operating in the area.
- CSXT requires prepayment for all work performed to design, implement, and maintain railroad facilities within Quiet Zones.
- CSXT desires to be a good corporate citizen. CSXT also places importance on the quality and timeliness of service to its customers and the communities it serves. As such, consistent with the Rule, CSXT will seek to encourage communities requesting Quiet Zones to implement solutions and SSMs that optimally achieve safety while minimizing the impact on railroad operations.
- CSXT has published a Quiet Zone Manual, located here:  
<https://www.csx.com/index.cfm/library/files/about-us/property/quiet-zones/>

## Overview

CSXT will fully comply with the Rule, which provides requirements for the sounding of locomotive horns when approaching public highway-rail grade crossings. The Rule also provides guidance for conditions under which a public authority with jurisdiction over the roadway crossing CSXT tracks may apply for and establish Quiet Zones. A Quiet Zone is a section of a rail line that contains one or more consecutive public crossings at which locomotive horns are not routinely sounded. (For full details on the rules, CSXT recommends that communities either visit the FRA web site at [www.fra.dot.gov](http://www.fra.dot.gov) or contact the FRA's Office of Safety at 202-493-6299).

## Policy on Quiet Zones

The Rule clearly defines requirements that must be satisfied by the public authority requesting that a Quiet Zone be established or continued. CSXT will expect the public authority to strictly comply with these requirements.

## Identification of the crossing and location

Each crossing has a unique DOT inventory identification number posted at the crossing. There is often more than one crossing on the same road. The crossing number (such as 123456A) must be used to identify the specific crossing in all communications with the railroad to reduce possible confusion about the specific location.

## Preliminary Planning for Quiet Zones

Preliminary work by CSXT personnel and/or its consultants is likely to be required in connection with the proposed new or continued Quiet Zone, including, but not limited to: updating crossing inventory information; attending meetings; participating, to the extent feasible, in diagnostic reviews of the public, private and pedestrian crossings in a proposed Quiet Zone; preparing and processing estimates covering the cost of work to be performed by CSXT, if applicable; and processing necessary agreements. CSXT will coordinate preliminary planning activities with each public authority pursuant to an initial agreement that will also provide for payment to CSXT for services provided during development of Quiet Zones.

## Getting Started: Process for Pursuing a Quiet Zone

1. Groups or individuals interested in Quiet Zones should first contact the public authority responsible for the highway where the Quiet Zone would be located. Public authorities should then contact the FRA for additional information on Quiet Zone requirements and procedures.
2. The public authority shall initiate contact with CSXT to: TellCSX@csx.com. Those making this contact will be furnished with the Quiet Zone policy and advised of the appropriate contact within the CSXT Public Projects Group for the initial planning activities with CSXT.
3. If the public authority decides to proceed with preliminary planning for a Quiet Zone, the public authority shall deposit funds with CSXT for CSXT's Quiet Zone related expenses. After this deposit is received, CSXT will assist by providing, when required, DOT inventory information and attending diagnostic review meetings, to the extent schedules permit. CSXT resources to attend these meetings are limited and thus CSXT will seek flexibility in establishing meeting dates and times in order to permit CSXT representatives to attend.
4. The preliminary planning for a Quiet Zone project should include a review of the following principles:
  - a. CSXT will cooperate and work in good faith with local communities and the appropriate public authority to provide all possible assistance in a manner that protects the safety of local citizens and their communities as well as CSXT's employees.
  - b. In accordance with the Rule, CSXT's support of a Quiet Zone proposal will require the plan to meet very specific FRA measures and requirements, which in some cases, may be subject to FRA review, approval and on-going oversight. Accordingly, CSXT retains the right to review and comment on the requests.
  - c. CSXT expects the involvement of the state DOT, FRA, and/or state regulatory authority in any diagnostic review of a public, private and pedestrian crossing in the Quiet Zone corridor being proposed.
  - d. As discussed above, the appropriate public authority will be expected to reimburse CSXT for its cost of design, installation and future maintenance of safety enhancements, including, but not limited to, its installation of Supplemental Safety Measures (SSMs) and Alternative Safety Measures (ASMs). As an example, CSXT installs and maintains active warning systems at highway-rail grade crossings that may be modified or expanded for a Quiet Zone. Curbs, medians, pavement markings and other traffic control signs such as advance warning signs are installed and maintained by Public Authorities. The specific responsibilities are expected to be resolved during the preliminary planning for a Quiet Zone.
  - e. If one or more SSMs or ASMs selected to be installed require work by CSXT, a separate standard Preliminary Engineering Agreement will be required to cover CSXT's engineering, review, handling, and estimate preparation connected with the proposed work. A separate Construction Agreement will be used for implementation of the projects. The cost of this work will be the responsibility of the requesting public authority.
  - f. SSMs or ASMs installed and maintained by the public authority as described above are important parts of traffic control at each crossing. The Public authority is responsible for periodic inspection and repair of these items.
5. Standard CSXT Public Projects Group design and estimating procedures will be used for projects related to Quiet Zones.
6. Vehicle Loop Detection Circuitry will not be designed, installed, owned, or maintained by CSXT.
7. Wayside Horn Systems are not authorized for use on CSXT.

# **APPENDIX**

**CSX Transportation**

## **PRELIMINARY ENGINEERING AGREEMENT**

Public Projects Group  
Jacksonville, FL  
Date Issued: July 2017

**[INSERT SCOPE; eg: PROPOSED BRIDGE REHABILITATION]**  
**[INSERT IMPACT; eg: RIDGEVIEW PEDESTRIAN BRIDGE OVER CSXT]**  
**[INSERT CITY/TOWN, COUNTY, STATE]**  
**IN VICINITY OF CSXT MILEPOST [INSERT RAILROAD MILEPOST]**  
**CSXT OP NUMBER [INSERT OP#]**

**PRELIMINARY ENGINEERING AGREEMENT**

This Preliminary Engineering Agreement (this "**Agreement**") is made as of \_\_\_\_\_, 201\_\_, by and between CSX TRANSPORTATION, INC., a Virginia corporation with its principal place of business in Jacksonville, Florida ("CSXT"), and **[INSERT AGENCY NAME]**, a body corporate and political subdivision of the **[INSERT STATE]** ("Agency").

**EXPLANATORY STATEMENT**

1. Agency wishes to facilitate the development of the proposed **[INSERT Project Description; eg: rehabilitation / repair of the Ridgeview Middle School Pedestrian Bridge Structure passing over CSXT (DOT# 228 637B) in the vicinity of CSXT milepost CD-6.15 on the Great Lakes Division, Columbus Subdivision, located in Columbus, Franklin County, Ohio]** (the "**Project**").
2. Agency has requested that CSXT proceed with certain necessary engineering and/or design services for the Project to facilitate the parties' consideration of the Project.
3. Subject to the approval of CSXT, which approval may be withheld for any reason directly or indirectly related to safety or CSXT operations, property, or facilities, the Project is to be constructed, if at all, at no cost to CSXT, under a separate construction agreement to be executed by the parties at a future date.

NOW, THEREFORE, for and in consideration of the foregoing Explanatory Statement and other good and valuable consideration, the receipt and sufficiency of which are acknowledged by the parties, the parties agree as follows:

1. Scope of Work

1.1. Generally. The work to be done by CSXT under this Agreement shall consist of: (i) the preparation or review and approval of preliminary and final engineering and design plans, specifications, drawings, agreements and other documents pertaining to the Project, (ii) the preparation of cost estimates for CSXT's work in connection with the Project, and (iii) the review of construction cost estimates, site surveys, assessments, studies, agreements and related construction documents submitted to CSXT by Agency for the Project (collectively, the "**Engineering Work**"). Engineering Work may also include office reviews, field reviews, attending hearings and meetings, and preparing correspondence, reports, and other documentation in connection with the Project. Nothing contained in this Agreement shall oblige CSXT to perform work which, in CSXT's opinion, is not relevant to CSXT's participation in the Project.

1.2. Effect of CSXT Approval or Preparation of Documents. By its review, approval or preparation of plans, specifications, drawings or other documents pursuant to this Agreement (collectively, the "**Plans**"), CSXT signifies only that the Plans and the Project proposed to be constructed in accordance with the Plans satisfy CSXT's requirements. CSXT expressly disclaims all other representations and warranties in connection with the Plans, including, but not limited to, the integrity, suitability or fitness for the purposes of Agency or any other persons of such Plans or the Project constructed in accordance with the Plans.

2. Project Construction. Nothing contained in this Agreement shall be deemed to constitute CSXT's approval of or consent to the construction of the Project, which approval or consent may be withheld for any reason directly or indirectly related to safety or CSXT operations, property, or facilities. The Project if constructed is to be constructed, if at all, under a separate construction agreement to be executed by the parties at a future date.

3. Reimbursement of CSXT Expenses.

3.1. Reimbursable Expenses. Agency shall reimburse CSXT for all costs and expenses incurred by CSXT in connection with the Engineering Work, including, without limitation: (i) all out of pocket expenses, (ii) travel and lodging expenses, (iii) telephone, facsimile, and mailing expenses, (iv) costs for equipment, tools, materials and supplies, (v) sums paid to consultants and subcontractors, and (vi) labor, together with labor overhead percentages established by CSXT pursuant to applicable law (collectively, the "**Reimbursable Expenses**").



**[INSERT SCOPE; eg: PROPOSED BRIDGE REHABILITATION]**  
**[INSERT IMPACT; eg: RIDGEVIEW PEDESTRIAN BRIDGE OVER CSXT]**  
**[INSERT CITY/TOWN, COUNTY, STATE]**  
**IN VICINITY OF CSXT MILEPOST [INSERT RAILROAD MILEPOST]**  
**CSXT OP NUMBER [INSERT OP#]**

3.2. Estimate. CSXT has estimated the total Reimbursable Expenses for the Project to be approximately \$ **[INSERT DOLLAR AMOUNT]** (the “**Estimate**” as amended or revised). In the event CSXT anticipates that actual Reimbursable Expenses may exceed such Estimate, it shall provide Agency with the revised Estimate of total Reimbursable Expenses for Agency’s approval and confirmation that sufficient funds have been appropriated to cover the total Reimbursable Expenses as reflected in the revised Estimate. CSXT may elect, by delivery of notice to Agency, to immediately cease all further Engineering Work, unless and until Agency provides such approval and confirmation.

3.3. Payment Terms.

3.3.1. Advance Payment in Full. Upon execution and delivery of this Agreement by Agency, Agency will deposit with CSXT a sum equal to the Reimbursable Expenses, as shown by the Estimate. Agency shall pay CSXT for Reimbursable Expenses in the amount set forth in **CSXT Schedule PA** attached hereto, a copy of which shall accompany the advance payment. If CSXT anticipates that it may incur Reimbursable Expenses in excess of the deposited amount, CSXT will request an additional deposit equal to the then remaining Reimbursable Expenses which CSXT estimates that it will incur. CSXT shall request such additional deposit by delivery of invoices to Agency. Agency shall make such additional deposit within thirty (30) days following delivery of such invoice to Agency.

3.3.2. Following completion of all Engineering Work, CSXT shall reconcile the total Reimbursable Expenses incurred by CSXT against the total payments received from Agency and shall submit to Agency a final invoice if required. Agency shall pay to CSXT the amount by which actual Reimbursable Expenses exceed total payments, as shown by the final invoice, within thirty (30) days following delivery to Agency of the final invoice. CSXT will provide a refund of any unused deposits if the deposit exceeds the incurred Reimbursable Expenses for the Project.

3.3.3. In the event that Agency fails to pay CSXT any sums due CSXT under this Agreement: (i) Agency shall pay CSXT interest at the lesser of 1.0% per month or the maximum rate of interest permitted by applicable law on the delinquent amount until paid in full; and (ii) CSXT may elect, by delivery of notice to Agency: (A) to immediately cease all further work on the Project, unless and until Agency pays the entire delinquent sum, together with accrued interest; and/or (B) to terminate this Agreement.

3.4. Effect of Termination. Agency’s obligation to pay CSXT Reimbursable Expenses in accordance with this Section shall survive termination of this Agreement for any reason.

4. Appropriations. Agency represents to CSXT that: (i) Agency has obtained appropriations sufficient to reimburse CSXT for the Reimbursable Expenses encompassed by the initial Estimate; (ii) Agency shall use its best efforts to obtain appropriations necessary to cover Reimbursable Expenses encompassed by subsequent Estimates approved by Agency; and (iii) Agency shall promptly notify CSXT in the event that Agency is unable to obtain such additional appropriations.

5. Termination.

5.1. By Agency. Agency may terminate this Agreement, for any reason, by delivery of notice to CSXT. Such termination shall become effective upon the expiration of fifteen (15) calendar days following delivery of notice to CSXT or such later date designated by the notice.

5.2. By CSXT. CSXT may terminate this Agreement (i) as provided pursuant to Section 3.3.3., or (ii) upon Agency’s breach of any of the terms of, or its obligations under, this Agreement and such breach continues without cure for a period of ninety (90) days after written notification from CSXT to Agency of such breach.

5.3. Consequences of Termination. If the Agreement is terminated by either party pursuant to this Section or any other provision of this Agreement, the parties understand that it may be impractical to immediately stop the Engineering Work. Accordingly, both parties agree that, in such instance a party may continue to perform Engineering Work until it has reached a point where it may reasonably and/or safely suspend the Engineering Work. Agency shall reimburse CSXT pursuant to this Agreement for the Engineering Work performed, plus all costs reasonably incurred by CSXT to

**[INSERT SCOPE; eg: PROPOSED BRIDGE REHABILITATION]  
[INSERT IMPACT; eg: RIDGEVIEW PEDESTRIAN BRIDGE OVER CSXT]  
[INSERT CITY/TOWN, COUNTY, STATE]  
IN VICINITY OF CSXT MILEPOST [INSERT RAILROAD MILEPOST]  
CSXT OP NUMBER [INSERT OP#]**

discontinue the Engineering Work and all other costs of CSXT incurred as a result of the Project up to the time of full suspension of the Engineering Work. Termination of this Agreement or Engineering Work on the Project, for any reason, shall not diminish or reduce Agency's obligation to pay CSXT for Reimbursable Expenses incurred in accordance with this Agreement. In the event of the termination of this Agreement or the Engineering Work for any reason, CSXT's only remaining obligation to Agency shall be to refund to Agency payments made to CSXT in excess of Reimbursable Expenses in accordance with Section 2.

6. Subcontracts. CSXT shall be permitted to engage outside consultants, counsel and subcontractors to perform all or any portion of the Engineering Work.

7. Notices. All notices, consents and approvals required or permitted by this Agreement shall be in writing and shall be deemed delivered (i) on the expiration of three (3) days following mailing by first class U.S. mail, (ii) on the next business day following mailing by a nationally recognized overnight carrier, or (iii) on the date of transmission, as evidenced by written confirmation of successful transmission, if by facsimile or other electronic transmission if sent on a business day (or if not sent on a business day, then on the next business day after the date sent), to the parties at the addresses set forth below, or such other addresses as either party may designate by delivery of prior notice to the other party:

If to CSXT: CSX Transportation, Inc.  
500 Water Street, J301  
Jacksonville, Florida 32202  
Attention: Director Project Management – Public Projects

If to Agency: \_\_\_\_\_  
\_\_\_\_\_  
\_\_\_\_\_

8. Entire Agreement. This Agreement embodies the entire understanding of the parties, may not be waived or modified except in a writing signed by authorized representatives of both parties, and supersedes all prior or contemporaneous written or oral understandings, agreements or negotiations regarding its subject matter. In the event of any inconsistency between this Agreement and the Exhibits, the more specific terms of the Exhibits shall be deemed controlling.

9. Waiver. If either party fails to enforce its respective rights under this Agreement, or fails to insist upon the performance of the other party's obligations hereunder, such failure shall not be construed as a permanent waiver of any rights or obligations in this Agreement.

10. Assignment. CSXT may assign this Agreement and all rights and obligations herein to a successor in interest, parent company, affiliate, or future affiliate. Upon assignment of this Agreement by CSXT and the assumption by CSXT's assignee of CSXT's obligations under this Agreement, CSXT shall have no further obligations under this Agreement. Agency shall not assign its rights or obligations under this Agreement without CSXT's prior written consent, which consent may be withheld for any reason.

11. Applicable Law. This Agreement shall be governed by the laws of the **[INSERT STATE]**, exclusive of its choice of law rules. The parties further agree that the venue of all legal and equitable proceedings related to disputes under this Agreement shall be situated in Duval County, Florida, and the parties agree to submit to the personal jurisdiction of any State or Federal court situated in Duval County, Florida.

**[INSERT SCOPE; eg: PROPOSED BRIDGE REHABILITATION]  
[INSERT IMPACT; eg: RIDGEVIEW PEDESTRIAN BRIDGE OVER CSXT]  
[INSERT CITY/TOWN, COUNTY, STATE]  
IN VICINITY OF CSXT MILEPOST [INSERT RAILROAD MILEPOST]  
CSXT OP NUMBER [INSERT OP#]**

IN WITNESS WHEREOF, the parties have caused this Agreement to be executed in duplicate, each by its duly authorized officers, as of the date of this Agreement.

**[INSERT AGENCY NAME]**

By: \_\_\_\_\_

Print Name: \_\_\_\_\_

Title: \_\_\_\_\_

**CSX TRANSPORTATION, INC.**

By: \_\_\_\_\_

Tony C. Bellamy, P.E.

Director Project Management – Public Projects

**CSXT Schedule PA**  
(Advance Payment – Preliminary Engineering Agreement)

**PAYMENT SUBMISSION FORM**

\*\*\*\*\*

Payment is hereby provided in accordance with the terms of Section 3.3 of the Agreement dated \_\_\_\_\_,  
201\_\_\_\_, between Agency and CSXT.

\*\*\*\*\*

1) A copy of this Payment Submission Form shall accompany all payments delivered by Agency to CSXT which shall be forwarded to the following address:

**CSX Transportation, Inc.  
PO BOX 530192  
ATLANTA GA 30353-0192**

2) Email copies of check and this form to Nicole\_Henning@csx.com and LShaw@Benesch.com

\*\*\*\*\*

Upon execution and delivery of this Agreement by Agency, Agency will remit payment in accordance with Section 3.3.1. of this Agreement.

\*\*\*\*\*

**(All information below to be completed by Agency providing Payment)**

Check No	Payment Amount	Payment Date
_____	_____	_____

\*\*\*\*\*

Date: \_\_\_\_\_ By: \_\_\_\_\_

Name: \_\_\_\_\_

Title: \_\_\_\_\_

Phone: \_\_\_\_\_

Email: \_\_\_\_\_

# **APPENDIX**

**CSX Transportation**

## **CONSTRUCTION AGREEMENT**

Public Projects Group  
Jacksonville, FL  
Date Issued: July 2017

**[INSERT SCOPE; eg: PROPOSED BRIDGE REHABILITATION]  
[INSERT IMPACT; eg: RIDGEVIEW PEDESTRIAN BRIDGE OVER CSXT]  
[INSERT CITY/TOWN, COUNTY, STATE]  
IN VICINITY OF CSXT MILEPOST [INSERT RAILROAD MILEPOST]  
CSXT OP NUMBER [INSERT OP#]**

**CONSTRUCTION AGREEMENT**

This Construction Agreement ("Agreement") is made as of \_\_\_\_\_, 201\_\_, by and between CSX TRANSPORTATION, INC., a Virginia corporation with its principal place of business in Jacksonville, Florida ("CSXT"), and **[INSERT Name of Public Agency]**, a body corporate and political subdivision of the State of **(INSERT Name of State)** ("Agency").

**EXPLANATORY STATEMENT**

1. Agency has proposed to construct, or to cause to be constructed, **[INSERT Project Description; eg: rehabilitation / repair of the Ridgeview Middle School Pedestrian Bridge Structure passing over CSXT (DOT# 228 637B) in the vicinity of CSXT milepost CD-6.15 on the Great Lakes Division, Columbus Subdivision, located in Columbus, Franklin County, Ohio]** (the "**Project**").
2. Agency has obtained, or will obtain, all authorizations, permits and approvals from all local, state and federal agencies (including Agency), and their respective governing bodies and regulatory agencies, necessary to proceed with the Project and to appropriate all funds necessary to construct the Project.
3. Agency acknowledges that: (i) by entering into this Agreement, CSXT will provide services and accommodations to promote public interest in this Project, without profit or other economic inducement typical of other Agency contractors; (ii) neither CSXT nor its affiliates (including their respective directors, officers, employees or agents) will incur any costs, expenses, losses or liabilities in excess of payments made to CSXT, by or on behalf of Agency or its contractors, pursuant to this Agreement; and (iii) CSXT retains the paramount right to regulate all activities affecting its property and operations.
4. It is the purpose of this Agreement to provide for the terms and conditions upon which the Project may proceed.

NOW, THEREFORE, in consideration of the foregoing Explanatory Statement and other good and valuable consideration, the receipt and sufficiency of which are acknowledged by the parties, the parties agree as follows:

1. **Project Plans and Specifications**

- 1.1 **Preparation and Approval.** Pursuant to Exhibit A of this Agreement, all plans, specifications, drawings and other documents necessary or appropriate to the design and construction of the Project shall be prepared, at Agency's sole cost and expense, by Agency or CSXT or their respective contractors. Project plans, specifications and drawings prepared by or on behalf of Agency shall be subject, at CSXT's election, to the review and approval of CSXT. Such plans, specifications and drawings, as prepared or approved by CSXT, are referred to as the "**Plans**", and shall be incorporated and deemed a part of this Agreement. Plans prepared or submitted to and approved by CSXT as of the date of this Agreement are set forth in Exhibit B to this Agreement.
- 1.2 **Effect of CSXT Approval or Preparation of Plans.** By its review, approval or preparation of Plans pursuant to this Agreement, CSXT signifies only that such Plans and improvements constructed in accordance with such Plans satisfy CSXT's requirements. CSXT expressly disclaims all other representations and warranties in connection with the Plans, including, but not limited to, the integrity, suitability or fitness for the purposes of Agency or any other persons of the Plans or improvements constructed in accordance with the Plans.
- 1.3 **Compliance with Plans.** The Project shall be constructed in accordance with the Plans.

**[INSERT SCOPE; eg: PROPOSED BRIDGE REHABILITATION]**  
**[INSERT IMPACT; eg: RIDGEVIEW PEDESTRIAN BRIDGE OVER CSXT]**  
**[INSERT CITY/TOWN, COUNTY, STATE]**  
**IN VICINITY OF CSXT MILEPOST [INSERT RAILROAD MILEPOST]**  
**CSXT OP NUMBER [INSERT OP#]**

## 2. Allocation and Conduct Of Work

Work in connection with the Project shall be allocated and conducted as follows:

- 2.1 CSXT Work. Subject to timely payment of Reimbursable Expenses as provided by Section 4, CSXT shall provide, or cause to be provided, the services as set forth by Exhibit A to this Agreement. Agency agrees that CSXT shall provide all services that CSXT deems necessary or appropriate (whether or not specified by Exhibit A) to preserve and maintain its property and operations, without impairment or exposure to liability of any kind and in compliance with all applicable federal, state and local regulations and CSXT's contractual obligations, including, but not limited to, CSXT's existing or proposed third party agreements and collective bargaining agreements.
  - 2.2 Agency Work. Agency shall perform, or cause to be performed, all work as set forth by Exhibit A, at Agency's sole cost and expense.
  - 2.3 Conduct of Work. CSXT shall commence its work under this Agreement following: (i) delivery to CSXT of a notice to proceed from Agency; (ii) payment of Reimbursable Expenses (as provided by Section 4.1) as required by CSXT prior to the commencement of work by CSXT; (iii) issuance of all permits, approvals and authorizations necessary or appropriate for such work; and (iv) delivery of proof of insurance acceptable to CSXT, as required by Section 9. The initiation of any services by CSXT pursuant to this Agreement, including, but not limited to, the issuance of purchase orders or bids for materials or services, shall constitute commencement of work for the purposes of this Section. The parties intend that all work by CSXT or on CSXT property shall conclude no later than **[INSERT DATE]**, unless the parties mutually agree to extend such date.
3. Special Provisions Agency shall observe and abide by, and shall require its contractors ("**Contractors**") to observe and abide by the terms, conditions and provisions set forth in Exhibit C to this Agreement (the "Special Provisions"). To the extent that Agency performs Project work itself, Agency shall be deemed a Contractor for purposes of this Agreement. Agency further agrees that, prior to the commencement of Project work by any third party Contractor, such Contractor shall execute and deliver to CSXT Schedule I to this Agreement to acknowledge Contractor's agreement to observe and abide by the terms and conditions of this Agreement.

## 4. Cost Of Project and Reimbursement Procedures

- 4.1 Reimbursable Expenses. Agency shall reimburse CSXT for all costs and expenses incurred by CSXT in connection with the Project, including, without limitation: (1) all out of pocket expenses, (2) travel and lodging expenses, (3) telephone, facsimile, and mailing expenses, (4) costs for equipment, tools, materials and supplies, (5) sums paid to CSXT's consultants and subcontractors, and (6) CSXT labor in connection with the Project, together with CSXT labor overhead percentages established by CSXT pursuant to applicable law (collectively, "**Reimbursable Expenses**"). Reimbursable Expenses shall also include expenses incurred by CSXT prior to the date of this Agreement to the extent identified by the Estimate provided pursuant to Section 4.2.
- 4.2 Estimate. CSXT has estimated the total Reimbursable Expenses for the Project as shown on Exhibit D (the "**Estimate**", as amended or revised). In the event CSXT anticipates that actual Reimbursable Expenses for the Project may exceed such Estimate, it shall provide Agency with the revised Estimate of the total Reimbursable Expenses, together with a revised Payment Schedule (as defined by Section 4.3.1), for Agency's approval and confirmation that sufficient funds have been appropriated to cover the total Reimbursable Expenses of such revised Estimate. CSXT may elect, by delivery of notice to Agency, to immediately cease all further work on the Project, unless and until Agency provides such approval and confirmation.

**[INSERT SCOPE; eg: PROPOSED BRIDGE REHABILITATION]  
[INSERT IMPACT; eg: RIDGEVIEW PEDESTRIAN BRIDGE OVER CSXT]  
[INSERT CITY/TOWN, COUNTY, STATE]  
IN VICINITY OF CSXT MILEPOST [INSERT RAILROAD MILEPOST]  
CSXT OP NUMBER [INSERT OP#]**

4.3 Payment Terms.

- 4.3.1 Agency shall pay CSXT for Reimbursable Expenses in the amounts and on the dates set forth in the Payment Schedule as shown on Exhibit E (the "Payment Schedule", as revised pursuant to Section 4.2). CSXT agrees to submit invoices to Agency for such amounts and Agency shall remit payment to CSXT at the later of thirty (30) days following delivery of each such invoice to Agency or, the payment date (if any) set forth in the Payment Schedule.
- 4.3.2 Following completion of the Project, CSXT shall submit to Agency a final invoice that reconciles the total Reimbursable Expenses incurred by CSXT against the total payments received from Agency. Agency shall pay to CSXT the amount by which Reimbursable Expenses exceed total payments as shown by the final invoice, within thirty (30) days following delivery of such invoice to Agency. In the event that the payments received by CSXT from Agency exceed the Reimbursable Expenses, CSXT shall remit such excess to Agency.
- 4.3.3 In the event that Agency fails to pay CSXT any sums due CSXT under this Agreement: (i) Agency shall pay CSXT interest at the lesser of 1.0% per month or the maximum rate of interest permitted by applicable law on the delinquent amount until paid in full; and (ii) CSXT may elect, by delivery of notice to Agency: (A) to immediately cease all further work on the Project, unless and until Agency pays the entire delinquent sum, together with accrued interest; and/or (B) to terminate this Agreement.
- 4.3.4 All invoices from CSXT shall be delivered to Agency in accordance with Section 16 of this Agreement. All payments by Agency to CSXT shall be made by certified check and mailed to the following address or such other address as designated by CSXT's notice to Agency:

CSX Transportation, Inc.  
P.O. Box 530192  
Atlanta, GA 30353-0192

- 4.4 Effect of Termination. Agency's obligation to pay to CSXT Reimbursable Expenses in accordance with Section 4 shall survive termination of this Agreement for any reason.

5. Appropriations Agency represents to CSXT that: (i) Agency has appropriated funds sufficient to reimburse CSXT for the Reimbursable Expenses encompassed by the Estimate attached as Exhibit D; (ii) Agency shall use its best efforts to obtain appropriations necessary to cover Reimbursable Expenses encompassed by subsequent Estimates approved by Agency; and (iii) Agency shall promptly notify CSXT in the event that Agency is unable to obtain such appropriations.

6. Easements and Licenses

- 6.1 Agency Obligation. Agency shall acquire all necessary licenses, permits and easements required for the Project.
- 6.2 Temporary Construction Licenses. Insofar as it has the right to do so, CSXT hereby grants Agency a nonexclusive license to access and cross CSXT's property, to the extent necessary for the construction of the Project (excluding ingress or egress over public grade crossings), along such routes and upon such terms as may be defined and imposed by CSXT and such temporary construction easements as may be designated on the Plans approved by CSXT.
- 6.3 Permanent Easements. Insofar as it has the right to do so, CSXT shall grant, without warranty to Agency, easements for the use and maintenance of the Project wholly or partly on CSXT property as shown on the Plans approved by CSXT, if any, on terms and conditions and at a price acceptable to the parties. Upon request by CSXT, Agency shall furnish to CSXT descriptions and plat plans for the easements.

7. Permits At its sole cost and expense, Agency shall procure all permits and approvals required by any federal, state, or local governments or governmental agencies for the construction, maintenance and use of the Project, copies of which shall be provided to CSXT.



**[INSERT SCOPE; eg: PROPOSED BRIDGE REHABILITATION]  
[INSERT IMPACT; eg: RIDGEVIEW PEDESTRIAN BRIDGE OVER CSXT]  
[INSERT CITY/TOWN, COUNTY, STATE]  
IN VICINITY OF CSXT MILEPOST [INSERT RAILROAD MILEPOST]  
CSXT OP NUMBER [INSERT OP#]**

## 8. Termination

- 8.1 By Agency. For any reason, Agency may, as its sole remedy, terminate this Agreement by delivery of notice to CSXT. Agency shall not be entitled to otherwise pursue claims for consequential, direct, indirect or incidental damages or lost profits as a consequence of CSXT's default or termination of this Agreement or Work on the Project by either party.
- 8.2 By CSXT. In addition to the other rights and remedies available to CSXT under this Agreement, CSXT may terminate this Agreement by delivery of notice to Agency in the event Agency or its Contractors fail to observe the terms or conditions of this Agreement and such failure continues more than ten (10) business days following delivery of notice of such failure by CSXT to Agency.
- 8.3 Consequences of Termination. If the Agreement is terminated by either party pursuant to this Section or any other provision of this Agreement, the parties understand that it may be impractical for them to immediately stop the Work. Accordingly, they agree that, in such instance a party may continue to perform Work until it has reached a point where it may reasonably and safely suspend the Work. Agency shall reimburse CSXT pursuant to this Agreement for the Work performed, plus all costs reasonably incurred by CSXT to discontinue the Work and protect the Work upon full suspension of the same, the cost of returning CSXT's property to its former condition, and all other costs of CSXT incurred as a result of the Project up to the time of full suspension of the Work. Termination of this Agreement or Work on the Project, for any reason, shall not diminish or reduce Agency's obligation to pay CSXT for Reimbursable Expenses incurred in accordance with this Agreement. In the event of the termination of this Agreement or the Work for any reason, CSXT's only remaining obligation to Agency shall be to refund to Agency payments made to CSXT in excess of Reimbursable Expenses in accordance with Section 4.

9. Insurance In addition to the insurance that Agency requires of its Contractor, Agency shall acquire or require its Contractor to purchase and maintain insurance in compliance with CSXT's insurance requirements attached to this Agreement as Exhibit F. Neither Agency nor Contractor shall commence work on the Project until such policy or policies have been submitted to and approved by CSXT's Risk Management Department.

## 10. Ownership and Maintenance

### **[SELECT ONE OF THE FOLLOWING ALTERNATE PROVISIONS:]**

- **Railroad Bridge**

- 10.1 By Agency. Agency shall own and, without cost to CSXT, shall maintain, repair, replace and renew, or cause same to be done, in good condition and repair to CSXT's satisfaction, the railroad bridge structure (excluding only those components which CSXT owns and has agreed to maintain, repair and replace pursuant to this Section), the highway underpass structure, the roadway surfacing, the roadway slopes, the retaining walls, the roadway drainage facilities, sidewalks and lighting. In the event that Agency fails to properly maintain such structures and improvements, and such failure, in the opinion of CSXT, jeopardizes the safe and efficient operation of its property, CSXT shall be entitled to remedy such failure and recover from Agency the costs incurred by CSXT in doing so.
- 10.2 By CSXT. CSXT shall own and, at its sole cost and expense, maintain, repair, replace and renew its tracks, ballast and approach embankments, and railroad signal and communication systems, and CSXT shall be permitted to install, maintain, repair and replace other utilities, facilities and cable, or cause same to be done, as CSXT authorizes from time to time on or within the railroad bridge structure.
- 10.3 Alterations. Agency shall not undertake any alteration, modification or expansion of the Project, without the prior approval of CSXT, which may be withheld for any reason, and the execution of such agreements as CSXT may require. CSXT may effectuate any improvements to that portion of the Project on which CSXT operates its rail line, without securing the prior approval of the Agency so long as such improvements will not have a negative impact on highway traffic using the highway underpass.

- **Highway Bridge**

- 10.1 By Agency. Agency shall own and, without cost to CSXT, maintain, repair, replace and renew, or cause same to be done, in good condition and repair to CSXT's satisfaction, the highway overpass structure, the roadway

**[INSERT SCOPE; eg: PROPOSED BRIDGE REHABILITATION]  
[INSERT IMPACT; eg: RIDGEVIEW PEDESTRIAN BRIDGE OVER CSXT]  
[INSERT CITY/TOWN, COUNTY, STATE]  
IN VICINITY OF CSXT MILEPOST [INSERT RAILROAD MILEPOST]  
CSXT OP NUMBER [INSERT OP#]**

surfacing, the roadway slopes, the retaining walls, and the highway drainage facilities. In the event that Agency fails to properly maintain such structures and improvements and such failure, in the opinion of CSXT, jeopardizes the safe and efficient operation of its property, CSXT shall be entitled to remedy such failure and recover from Agency the costs incurred by CSXT in doing so. Upon the cessation of use of the Project by Agency, Agency shall remove the bridge structure and restore CSXT's property to its original condition, at Agency's sole cost and expense, to CSXT's satisfaction.

10.2 Alterations. Agency shall not undertake any alteration, modification or expansion of the Project, without the prior approval of CSXT, which may be withheld for any reason, and the execution of such agreements as CSXT may require.

- **At Grade Crossings**

10.1 By Agency. Agency shall maintain and repair, at its sole cost and expense, all parts comprising the permanent aspects of the Project, as shown by the Plans, consisting of roadway pavement up to the outer ends of the railroad cross ties, sidewalks, guardrails, and curbs, in good and safe condition to CSXT's satisfaction. In the event Agency fails to do so after reasonable notice from CSXT (unless an emergency condition exists or is imminent in the opinion of CSXT that requires immediate action), CSXT may perform such maintenance and repair, at Agency's sole cost and expense.

10.2 By CSXT. CSXT shall maintain and repair the crossing surface between the ends of its cross ties and its signal facilities at the crossing, at Agency's sole cost and expense.

10.3 Alterations. Agency shall not undertake any alteration, modification or expansion of the Project, without the prior written approval of CSXT, which may be withheld for any reason, and the execution of such agreements as CSXT may require. CSXT may undertake alterations of its property, track or facilities and shall be reimbursed by Agency for the expenses incurred by CSXT with respect to the removal and restoration of the crossing in connections with such alteration.

- **Other Improvements**

10.1 By Agency. Agency shall own, maintain and repair, at its sole cost and expense, all parts comprising the permanent aspects of the Project, as shown by the Plans. In the event Agency fails to do so after reasonable notice from CSXT (no more than thirty (30) days, unless an emergency condition exists or is imminent in the opinion of CSXT, that requires immediate action), CSXT may perform such maintenance and repair, at Agency's sole cost and expense. Upon the cessation of use of the Project by Agency, Agency shall remove the structure and restore CSXT's property to its original condition, at Agency's sole cost and expense, to CSXT's satisfaction.

10.2 Alterations. Agency shall not undertake any alteration, modification or expansion of the Project, without the prior approval of CSXT, which may be withheld for any reason, and the execution of such agreements as CSXT may require.

## 11. Indemnification

11.1 Generally. To the maximum extent permitted by applicable law, Agency and its Contractors shall indemnify, defend, and hold CSXT and its affiliates harmless from and against all claims, demands, payments, suits, actions, judgments, settlements, and damages of every nature, degree, and kind (including direct, indirect, consequential, incidental, and punitive damages), for any injury to or death to any person(s) (including, but not limited to the employees of CSXT, its affiliates, Agency or its Contractors), for the loss of or damage to any property whatsoever (including but not limited to property owned by or in the care, custody, or control of CSXT, its affiliates, Agency or its Contractors, and environmental damages and any related remediation brought or recovered against CSXT and its affiliates), arising directly or indirectly from the negligence, recklessness or intentional wrongful misconduct of the Contractors, Agency, and their respective agents, employees, invitees, contractors, or its contractors' agents, employees or invitees in the performance of work in connection with the Project or activities incidental thereto, or from their presence on or about CSXT's property. The foregoing indemnification obligation shall not be limited to the insurance coverage required by this Agreement, except to the extent required by law or otherwise expressly provided by this Agreement.

**[INSERT SCOPE; eg: PROPOSED BRIDGE REHABILITATION]  
[INSERT IMPACT; eg: RIDGEVIEW PEDESTRIAN BRIDGE OVER CSXT]  
[INSERT CITY/TOWN, COUNTY, STATE]  
IN VICINITY OF CSXT MILEPOST [INSERT RAILROAD MILEPOST]  
CSXT OP NUMBER [INSERT OP#]**

- 11.2 Compliance with Laws. Agency shall comply, and shall require its Contractors to comply, with any federal, state, or local laws, statutes, codes, ordinances, rules, and regulations applicable to its construction and maintenance of the Project. Agency's Contractors shall indemnify, defend, and hold CSXT and its affiliates harmless with respect to any fines, penalties, liabilities, or other consequences arising from breaches of this Section.
- 11.3 "CSXT Affiliates". For the purpose of this Section 11, CSXT's affiliates include CSX Corporation and all entities, directly or indirectly, owned or controlled by or under common control of CSXT or CSX Corporation and their respective officers, directors, employees and agents.
- 11.4 Notice of Incidents. Agency and its Contractor shall notify CSXT promptly of any loss, damage, injury or death arising out of or in connection with the Project work.
- 11.5 Survival. The provisions of this Section 11 shall survive the termination or expiration of this Agreement.
12. Independent Contractor The parties agree that neither Agency nor its Contractors shall be deemed either agents or independent contractors of CSXT. Except as otherwise provided by this Agreement, CSXT shall exercise no control whatsoever over the employment, discharge, compensation of, or services rendered by Agency or Agency's Contractors, or the construction practices, procedures, and professional judgment employed by Agency or its Contractor to complete the Project. Notwithstanding the foregoing, this Section 12 shall in no way affect the absolute authority of CSXT to prohibit Agency or its Contractors or anyone from entering CSXT's property, or to require the removal of any person from its property, if it determines, in its sole discretion, that such person is not acting in a safe manner or that actual or potential hazards in, on or about the Project exist.
13. "Entire Agreement" This Agreement embodies the entire understanding of the parties, may not be waived or modified except in a writing signed by authorized representatives of both parties, and supersedes all prior or contemporaneous written or oral understandings, agreements or negotiations regarding its subject matter. In the event of any inconsistency between this Agreement and the Exhibits, the more specific terms of the Exhibits shall be deemed controlling.
14. Waiver If either party fails to enforce its respective rights under this Agreement, or fails to insist upon the performance of the other party's obligations hereunder, such failure shall not be construed as a permanent waiver of any rights or obligations in this Agreement.
15. Assignment CSXT may assign this Agreement and all rights and obligations herein to a successor in interest, parent company, affiliate, or future affiliate. Upon assignment of this Agreement by CSXT and the assumption of CSXT's assignee of CSXT's obligations under this Agreement, CSXT shall have no further obligation under this Agreement. Agency shall not assign its rights or obligations under this Agreement without CSXT's prior consent, which consent may be withheld for any reason.
16. Notices All notices, consents and approvals required or permitted by this Agreement shall be in writing and shall be deemed delivered upon personal delivery, upon the expiration of three (3) days following mailing by first class U.S. mail, or upon the next business day following mailing by a nationally recognized overnight carrier, to the parties at the addresses set forth below, or such other addresses as either party may designate by delivery of prior notice to the other party:

If to CSXT: CSX Transportation, Inc.  
500 Water Street, J301  
Jacksonville, Florida 32202  
Attention: Director Project Management – Public Projects

If to Agency: \_\_\_\_\_  
\_\_\_\_\_  
\_\_\_\_\_  
\_\_\_\_\_

**[INSERT SCOPE; eg: PROPOSED BRIDGE REHABILITATION]  
[INSERT IMPACT; eg: RIDGEVIEW PEDESTRIAN BRIDGE OVER CSXT]  
[INSERT CITY/TOWN, COUNTY, STATE]  
IN VICINITY OF CSXT MILEPOST [INSERT RAILROAD MILEPOST]  
CSXT OP NUMBER [INSERT OP#]**

17. Severability The parties agree that if any part, term or provision of this Agreement is held to be illegal, unenforceable or in conflict with any applicable federal, state, or local law or regulation, such part, term or provision shall be severable, with the remainder of the Agreement remaining valid and enforceable.

18. Applicable Law This Agreement shall be governed by the laws of the State of **[INSERT STATE OF PROJECT LOCATION]**, exclusive of its choice of law rules. The parties further agree that the venue of all legal and equitable proceedings related to disputes under this Agreement shall be situated in Duval County, Florida, and the parties agree to submit to the personal jurisdiction of any State or Federal court situated in Duval County, Florida.

IN WITNESS WHEREOF, the parties have caused this Agreement to be executed in duplicate, each by its duly authorized officers, as of the date of this Agreement.

**[INSERT NAME OF AGENCY]**

By: \_\_\_\_\_

Print Name: \_\_\_\_\_

Title: \_\_\_\_\_

CSX TRANSPORTATION, INC.

By: \_\_\_\_\_

Tony C. Bellamy, P.E.

Director Project Management-Public Projects

**[INSERT SCOPE; eg: PROPOSED BRIDGE REHABILITATION]  
[INSERT IMPACT; eg: RIDGEVIEW PEDESTRIAN BRIDGE OVER CSXT]  
[INSERT CITY/TOWN, COUNTY, STATE]  
IN VICINITY OF CSXT MILEPOST [INSERT RAILROAD MILEPOST]  
CSXT OP NUMBER [INSERT OP#]**

**EXHIBIT A**  
ALLOCATION OF WORK

Subject to Section 2.1, work to be performed in connection with the Project is allocated as follows:

- A. Agency shall let by contract to its Contractors:
  - 1. [INSERT DESCRIPTION OF WORK]
- B. CSXT shall perform or cause to be performed:
  - 1. Preliminary engineering services.
  - 2. Changes in communication and signal lines.
  - 3. Flagging services and other protective services and devices as may be necessary.
  - 4. Construction engineering and inspection to protect the interests of CSXT.

**[INSERT SCOPE; eg: PROPOSED BRIDGE REHABILITATION]  
[INSERT IMPACT; eg: RIDGEVIEW PEDESTRIAN BRIDGE OVER CSXT]  
[INSERT CITY/TOWN, COUNTY, STATE]  
IN VICINITY OF CSXT MILEPOST [INSERT RAILROAD MILEPOST]  
CSXT OP NUMBER [INSERT OP#]**

## **EXHIBIT B**

### PLANS AND SPECIFICATIONS

Plans, Specifications and Drawings:

As of the date of this Agreement, the following plans, specifications and drawings have been submitted by Agency to CSXT for its review and approval:

**[IDENTIFY PLANS AND SPECIFICATIONS BY DATE, PREPARER, TITLE, PROJECT NUMBER, ETC.]**

<b>SHEET</b>	<b>DESCRIPTION</b>	<b>PREPARER</b>	<b>DATE</b>
1 of			

**[INSERT SCOPE; eg: PROPOSED BRIDGE REHABILITATION]  
[INSERT IMPACT; eg: RIDGEVIEW PEDESTRIAN BRIDGE OVER CSXT]  
[INSERT CITY/TOWN, COUNTY, STATE]  
IN VICINITY OF CSXT MILEPOST [INSERT RAILROAD MILEPOST]  
CSXT OP NUMBER [INSERT OP#]**

**EXHIBIT C**

CSXT SPECIAL PROVISIONS

DEFINITIONS:

As used in these Special Provisions, all capitalized terms shall have the meanings ascribed to them by the Agreement, and the following terms shall have the meanings ascribed to them below:

“CSXT” shall mean CSX Transportation, Inc., its successors and assigns.

“CSXT Representative” shall mean the authorized representative of CSX Transportation, Inc.

“Agreement” shall mean the Agreement between CSXT and Agency, as amended from time to time.

“Agency” shall mean the **[INSERT NAME OF AGENCY]**.

“Agency Representative” shall mean the authorized representative of **[INSERT NAME OF AGENCY]**.

“Contractor” shall have the meaning ascribed to such term by the Agreement.

“Work” shall mean the Project as described in the Agreement.

I. AUTHORITY OF CSXT ENGINEER

The CSXT Representative shall have final authority in all matters affecting the safe maintenance of CSXT operations and CSXT property, and his or her approval shall be obtained by the Agency or its Contractor for methods of construction to avoid interference with CSXT operations and CSXT property and all other matters contemplated by the Agreement and these Special Provisions.

II. INTERFERENCE WITH CSXT OPERATIONS

- A. Agency or its Contractor shall arrange and conduct its work so that there will be no interference with CSXT operations, including train, signal, telephone and telegraphic services, or damage to CSXT’s property, or to poles, wires, and other facilities of tenants on CSXT’s Property or right-of-way. Agency or its Contractor shall store materials so as to prevent trespassers from causing damage to trains, or CSXT Property. Whenever Work is likely to affect the operations or safety of trains, the method of doing such Work shall first be submitted to the CSXT Representative for approval, but such approval shall not relieve Agency or its Contractor from liability in connection with such Work.
- B. If conditions arising from or in connection with the Project require that immediate and unusual provisions be made to protect train operation or CSXT’s property, Agency or its Contractor shall make such provision. If the CSXT Representative determines that such provision is insufficient, CSXT may, at the expense of Agency or its Contractor, require or provide such provision as may be deemed necessary, or cause the Work to cease immediately.

III. NOTICE OF STARTING WORK. Agency or its Contractor shall not commence any work on CSXT Property or rights-of-way until it has complied with the following conditions:

- A. Notify CSXT in writing of the date that it intends to commence Work on the Project. Such notice must be received by CSXT at least ten business days in advance of the date Agency or its Contractor proposes to begin Work on CSXT property. The notice must refer to this Agreement by date. If flagging service is required, such notice shall be submitted at least thirty (30) business days in advance of the date scheduled to commence the Work.

**[INSERT SCOPE; eg: PROPOSED BRIDGE REHABILITATION]  
[INSERT IMPACT; eg: RIDGEVIEW PEDESTRIAN BRIDGE OVER CSXT]  
[INSERT CITY/TOWN, COUNTY, STATE]  
IN VICINITY OF CSXT MILEPOST [INSERT RAILROAD MILEPOST]  
CSXT OP NUMBER [INSERT OP#]**

- B. Obtain authorization from the CSXT Representative to begin Work on CSXT property, such authorization to include an outline of specific conditions with which it must comply.
- C. Obtain from CSXT the names, addresses and telephone numbers of CSXT's personnel who must receive notice under provisions in the Agreement. Where more than one individual is designated, the area of responsibility of each shall be specified.

IV. WORK FOR THE BENEFIT OF THE CONTRACTOR

- A. No temporary or permanent changes to wire lines or other facilities (other than third party fiber optic cable transmission systems) on CSXT property that are considered necessary to the Work are anticipated or shown on the Plans. If any such changes are, or become, necessary in the opinion of CSXT or Agency, such changes will be covered by appropriate revisions to the Plans and by preparation of a force account estimate. Such force account estimate may be initiated by either CSXT or Agency, but must be approved by both CSXT and Agency. Agency or Contractor shall be responsible for arranging for the relocation of the third party fiber optic cable transmission systems, at no cost or expense to CSXT.
- B. Should Agency or Contractor desire any changes in addition to the above, then it shall make separate arrangements with CSXT for such changes to be accomplished at the Agency or Contractor's expense.

V. HAUL ACROSS RAILROAD

- A. If Agency or Contractor desires access across CSXT property or tracks at other than an existing and open public road crossing in or incident to construction of the Project, the Agency or Contractor must first obtain the permission of CSXT and shall execute a license agreement or right of entry satisfactory to CSXT, wherein Agency or Contractor agrees to bear all costs and liabilities related to such access.
- B. Agency and Contractor shall not cross CSXT's property and tracks with vehicles or equipment of any kind or character, except at such crossing or crossings as may be permitted pursuant to this section.

VI. COOPERATION AND DELAYS

- A. Agency or Contractor shall arrange a schedule with CSXT for accomplishing stage construction involving work by CSXT. In arranging its schedule, Agency or Contractor shall ascertain, from CSXT, the lead time required for assembling crews and materials and shall make due allowance therefore.
- B. Agency or Contractor may not charge any costs or submit any claims against CSXT for hindrance or delay caused by railroad traffic; work done by CSXT or other delay incident to or necessary for safe maintenance of railroad traffic; or for any delays due to compliance with these Special Provisions.
- C. Agency and Contractor shall cooperate with others participating in the construction of the Project to the end that all work may be carried on to the best advantage.
- D. Agency and Contractor understand and agree that CSXT does not assume any responsibility for work performed by others in connection the Project. Agency and Contractor further understand and agree that they shall have no claim whatsoever against CSXT for any inconvenience, delay or additional cost incurred by Agency or Contractor on account of operations by others.

VII. STORAGE OF MATERIALS AND EQUIPMENT

Agency and Contractor shall not store their materials or equipment on CSXT's property or where they may potentially interfere with CSXT's operations, unless Agency or Contractor has received CSXT Representative's prior written permission. Agency and Contractor understand and agree that CSXT will not be liable for any damage to such materials and equipment from any cause and that CSXT may move, or require Agency or Contractor to move, such



**[INSERT SCOPE; eg: PROPOSED BRIDGE REHABILITATION]  
[INSERT IMPACT; eg: RIDGEVIEW PEDESTRIAN BRIDGE OVER CSXT]  
[INSERT CITY/TOWN, COUNTY, STATE]  
IN VICINITY OF CSXT MILEPOST [INSERT RAILROAD MILEPOST]  
CSXT OP NUMBER [INSERT OP#]**

material and equipment at Agency's or Contractor's sole expense. To minimize the possibility of damage to the railroad tracks resulting from the unauthorized use of equipment, all grading or other construction equipment that is left parked near the tracks unattended by watchmen shall be immobilized to the extent feasible so that it cannot be moved by unauthorized persons.

VIII. CONSTRUCTION PROCEDURES

A. General

1. Construction work on CSXT property shall be subject to CSXT's inspection and approval.
2. Construction work on CSXT property shall be in accord with CSXT's written outline of specific conditions and with these Special Provisions.
3. Contractor shall observe the terms and rules of the CSXT Safe Way manual, which Agency and Contractor shall be required to obtain from CSXT, and in accord with any other instructions furnished by CSXT or CSXT's Representative.

B. Blasting

1. Agency or Contractor shall obtain CSXT Representative's and Agency Representative's prior written approval for use of explosives on or adjacent to CSXT property. If permission for use of explosives is granted, Agency or Contractor must comply with the following:
  - a. Blasting shall be done with light charges under the direct supervision of a responsible officer or employee of Agency or Contractor.
  - b. Electric detonating fuses shall not be used because of the possibility of premature explosions resulting from operation of two-way train radios.
  - c. No blasting shall be done without the presence of an authorized representative of CSXT. At least 10 days' advance notice to CSXT Representative is required to arrange for the presence of an authorized CSXT representative and any flagging that CSXT may require.
  - d. Agency or Contractor must have at the Project site adequate equipment, labor and materials, and allow sufficient time, to (i) clean up (at Agency's expense) debris resulting from the blasting without any delay to trains; and (ii) correct (at Agency's expense) any track misalignment or other damage to CSXT's property resulting from the blasting, as directed by CSXT Representative, without delay to trains. If Agency's or Contractor's actions result in delay of any trains, including Amtrak passenger trains, Agency shall bear the entire cost thereof.
  - e. Agency and Contractor shall not store explosives on CSXT property.
2. CSXT Representative will:
  - a. Determine the approximate location of trains and advise Agency or Contractor of the approximate amount of time available for the blasting operation and clean-up.
  - b. Have the authority to order discontinuance of blasting if, in his or her opinion, blasting is too hazardous or is not in accord with these Special Provisions.

IX. MAINTENANCE OF DITCHES ADJACENT TO CSXT TRACKS

Agency or Contractor shall maintain all ditches and drainage structures free of silt or other obstructions that may result from their operations. Agency or Contractor shall provide erosion control measures during construction and use methods that accord with applicable state standard specifications for road and bridge construction, including either

**[INSERT SCOPE; eg: PROPOSED BRIDGE REHABILITATION]  
[INSERT IMPACT; eg: RIDGEVIEW PEDESTRIAN BRIDGE OVER CSXT]  
[INSERT CITY/TOWN, COUNTY, STATE]  
IN VICINITY OF CSXT MILEPOST [INSERT RAILROAD MILEPOST]  
CSXT OP NUMBER [INSERT OP#]**

(1) silt fence; (2) hay or straw barrier; (3) berm or temporary ditches; (4) sediment basin; (5) aggregate checks; and (6) channel lining. All such maintenance and repair of damages due to Agency's or Contractor's operations shall be performed at Agency's expense.

X. FLAGGING / INSPECTION SERVICE

- A. CSXT has sole authority to determine the need for flagging required to protect its operations and property. In general, flagging protection will be required whenever Agency or Contractor or their equipment are, or are likely to be, working within fifty (50) feet of live track or other track clearances specified by CSXT, or over tracks.
- B. Agency shall reimburse CSXT directly for all costs of flagging that is required on account of construction within CSXT property shown in the Plans, or that is covered by an approved plan revision, supplemental agreement or change order.
- C. Agency or Contractor shall give a minimum of 10 days' advance notice to CSXT Representative for anticipated need for flagging service. No work shall be undertaken until the flag person(s) is/are at the job site. If it is necessary for CSXT to advertise a flagging job for bid, it may take up to 90-days to obtain this service, and CSXT shall not be liable for the cost of delays attributable to obtaining such service.
- D. CSXT shall have the right to assign an individual to the site of the Project to perform inspection service whenever, in the opinion of CSXT Representative, such inspection may be necessary. Agency shall reimburse CSXT for the costs incurred by CSXT for such inspection service. Inspection service shall not relieve Agency or Contractor from liability for its Work.
- E. CSXT shall render invoices for, and Agency shall pay for, the actual pay rate of the flagpersons and inspectors used, plus standard additives, whether that amount is above or below the rate provided in the Estimate. If the rate of pay that is to be used for inspector or flagging service is changed before the work is started or during the progress of the work, whether by law or agreement between CSXT and its employees, or if the tax rates on labor are changed, bills will be rendered by CSXT and paid by Agency using the new rates. Agency and Contractor shall perform their operations that require flagging protection or inspection service in such a manner and sequence that the cost of such will be as economical as possible.

XI. UTILITY FACILITIES ON CSXT PROPERTY

Agency shall arrange, upon approval from CSXT, to have any utility facilities on or over CSXT Property changed as may be necessary to provide clearances for the proposed trackage.

XII. CLEAN-UP

Agency or Contractor, upon completion of the Project, shall remove from CSXT's Property any temporary grade crossings, any temporary erosion control measures used to control drainage, all machinery, equipment, surplus materials, falsework, rubbish, or temporary buildings belonging to Agency or Contractor. Agency or Contractor, upon completion of the Project, shall leave CSXT Property in neat condition, satisfactory to CSXT Representative.

XIII. FAILURE TO COMPLY

If Agency or Contractor violate or fail to comply with any of the requirements of these Special Provisions, (a) CSXT may require Agency and/or Contractor to vacate CSXT Property; and (b) CSXT may withhold monies due Agency and/or Contractor; (c) CSXT may require Agency to withhold monies due Contractor; and (d) CSXT may cure such failure and the Agency shall reimburse CSXT for the cost of curing such failure.

**[INSERT SCOPE; eg: PROPOSED BRIDGE REHABILITATION]  
[INSERT IMPACT; eg: RIDGEVIEW PEDESTRIAN BRIDGE OVER CSXT]  
[INSERT CITY/TOWN, COUNTY, STATE]  
IN VICINITY OF CSXT MILEPOST [INSERT RAILROAD MILEPOST]  
CSXT OP NUMBER [INSERT OP#]**

## **EXHIBIT D**

INITIAL ESTIMATE  
ATTACHED

**[INSERT SCOPE; eg: PROPOSED BRIDGE REHABILITATION]  
[INSERT IMPACT; eg: RIDGEVIEW PEDESTRIAN BRIDGE OVER CSXT]  
[INSERT CITY/TOWN, COUNTY, STATE]  
IN VICINITY OF CSXT MILEPOST [INSERT RAILROAD MILEPOST]  
CSXT OP NUMBER [INSERT OP#]**

**EXHIBIT E**

PAYMENT SCHEDULE

**[SELECT ONE OF FOLLOWING ALTERNATE PROVISIONS:]**

**Advance Payment in Full**

Upon execution and delivery of notice to proceed with the Project, Agency will deposit with CSXT a sum equal to the Reimbursable Expenses, as shown by the Estimate. If CSXT anticipates that it may incur Reimbursable Expenses in excess of the deposited amount, CSXT will request an additional deposit equal to the then remaining Reimbursable Expenses which CSXT estimates that it will incur. CSXT shall request such additional deposit by delivery of invoices to Agency. Agency shall make such additional deposit within 30 days following delivery of such invoice to Agency.

**50/50 Payment in Advance**

Upon delivery of notice to proceed with the Project, Agency will deposit with CSXT a sum equal to fifty percent (50%) of the Reimbursable Expenses as shown by the Estimate. Prior to the incurrence of Reimbursable Expenses in excess of such deposit, CSXT will request an additional deposit equal to the Reimbursable Expenses which CSXT expects to incur. CSXT shall request such additional deposit by delivery of invoices to Agency. Agency shall make such additional deposits within 30 days following delivery of such invoice to Agency.

**Scheduled Payments**

Agency shall deposit with CSXT the following sums on or before the dates set forth below, which sums and dates shall be subject to adjustment in the event of revisions to the Estimate:

Payment Date:	Payment:
_____	_____
Total:	_____

**Progress Payments In Arrears**

Notwithstanding anything to the contrary set forth in this Agreement, Agency shall pay CSXT in arrears for its Reimbursable Expenses, rather than in advance, with only such exceptions, such as purchasing materials and equipment, as the parties mutually agree. Accordingly, Agency shall remit payment to CSXT for its Reimbursable Expenses within thirty (30) days following delivery to Agency of an invoice.

# EXHIBIT F

## INSURANCE REQUIREMENTS

### I. Insurance Policies

Agency and Contractor, if and to the extent that either is performing work on or about CSXT's property, shall procure and maintain the following insurance policies:

1. Commercial General Liability coverage at their sole cost and expense with limits of not less than \$5,000,000 in combined single limits for bodily injury and/or property damage per occurrence, and such policies shall name CSXT as an additional named insured.
2. Statutory Worker's Compensation and Employers Liability Insurance with limits of not less than \$1,000,000, which insurance must contain a waiver of subrogation against CSXT and its affiliates (if permitted by state law).
3. Commercial automobile liability insurance with limits of not less than \$1,000,000 combined single limit for bodily injury and/or property damage per occurrence, and such policies shall name CSXT as an additional named insured.
4. Railroad protective liability insurance with limits of not less than \$5,000,000 combined single limit for bodily injury and/or property damage per occurrence and an aggregate annual limit of \$10,000,000, which insurance shall satisfy the following additional requirements:
  - a. The Railroad Protective Insurance Policy must be on the ISO/RIMA Form of Railroad Protective Insurance - Insurance Services Office (ISO) Form CG 00 35.
  - b. CSX Transportation must be the named insured on the Railroad Protective Insurance Policy.
  - c. Name and Address of Contractor and Agency must appear on the Declarations page.
  - d. Description of operations must appear on the Declarations page and must match the Project description.
  - e. Authorized endorsements must include the Pollution Exclusion Amendment - CG 28 31, unless using form CG 00 35 version 96 and later.
  - f. Authorized endorsements may include:
    - (i). Broad Form Nuclear Exclusion - IL 00 21
    - (ii) 30-day Advance Notice of Non-renewal or cancellation
    - (iii) Required State Cancellation Endorsement
    - (iv) Quick Reference or Index - CL/IL 240
  - g. Authorized endorsements may not include:
    - (i) A Pollution Exclusion Endorsement except CG 28 31
    - (ii) A Punitive or Exemplary Damages Exclusion
    - (iii) A "Common Policy Conditions" Endorsement
    - (iv) Any endorsement that is not named in Section 4 (e) or (f) above.
    - (v) Policies that contain any type of deductible
5. All insurance companies must be A. M. Best rated A- and Class VII or better.
6. The CSX OP number or CSX contract number, as applicable, must appear on each Declarations page and/or certificates of insurance.
7. Such additional or different insurance as CSXT may require.

**[INSERT SCOPE; eg: PROPOSED BRIDGE REHABILITATION]  
[INSERT IMPACT; eg: RIDGEVIEW PEDESTRIAN BRIDGE OVER CSXT]  
[INSERT CITY/TOWN, COUNTY, STATE]  
IN VICINITY OF CSXT MILEPOST [INSERT RAILROAD MILEPOST]  
CSXT OP NUMBER [INSERT OP#]**

II. Additional Terms

1. Contractor must submit the complete Railroad Protective Liability policy, Certificates of Insurance and all notices and correspondence regarding the insurance policies in an electronic format to:

Insurance Department  
CSX Transportation, Inc.  
500 Water Street, C-907  
Jacksonville, FL 32202

OR

insurancedocuments@csx.com

2. Neither Agency nor its Designee may begin work on or about CSXT property until written approval of the required insurance has been received from CSXT or CSXT's Insurance Compliance vendor, Ebix.

**[INSERT SCOPE; eg: PROPOSED BRIDGE REHABILITATION]  
[INSERT IMPACT; eg: RIDGEVIEW PEDESTRIAN BRIDGE OVER CSXT]  
[INSERT CITY/TOWN, COUNTY, STATE]  
IN VICINITY OF CSXT MILEPOST [INSERT RAILROAD MILEPOST]  
CSXT OP NUMBER [INSERT OP#]**

**SCHEDULE I**

CONTRACTOR'S ACCEPTANCE

To and for the benefit of CSX Transportation, Inc. ("CSXT") and to induce CSXT to permit Contractor on or about CSXT's property for the purposes of performing work in accordance with the Agreement dated \_\_\_\_\_, 201\_\_, between **[INSERT NAME OF AGENCY]** and CSXT, Contractor hereby agrees to abide by and perform all applicable terms of the Agreement, including, but not limited to Exhibits C and F to the Agreement, and Sections 3, 9 and 11 of the Agreement.

Contractor: \_\_\_\_\_

By: \_\_\_\_\_

Name: \_\_\_\_\_

Title: \_\_\_\_\_

Date: \_\_\_\_\_

\\COR\130459.7

# **APPENDIX**

**CSX Transportation**

## **TEMPORARY RIGHT OF ENTRY AGREEMENT**

Public Projects Group  
Jacksonville, FL  
Date Issued: July 2017



**CSX Transportation, Inc.**  
**Temporary Right of Entry Agreement**

**THIS AGREEMENT**, made as of \_\_\_\_\_, 20\_\_\_\_, by and between CSX TRANSPORTATION, INC., a Virginia corporation, whose mailing address is 500 Water Street, Jacksonville, Florida 32202, hereinafter called “**CSXT**,” and (\*\*\*\*\*), whose mailing address is (\*\*\*\*\*), (\*\*\*\*\*), hereinafter called “**Licensee**,” WITNESSETH:

**WHEREAS**, Licensee has submitted a written application to CSXT requesting permission to enter CSXT’s property located within the (\*\*\*\*) Division, (\*\*\*\*) Subdivision, at DOT#: (\*\*\*\*) MP (\*\*\*\*). (\*\*Street\*\*) in (\*\*City\*\*), (\*\*) County, (\*\*State\*\*) (the “**Property**”), (description of scope of work), beginning (\*\*) feet from the (\*\*\*\*) and (\*\*) right of way, (the “**Project**”).

**WHEREAS**, CSXT is willing to grant to Licensee the limited right and permission to enter upon the Property for the limited purpose of performing the Project.

**NOW THEREFORE**, CSXT hereby grants to Licensee the right and permission to enter upon the Property for the purpose of performing said Project, subject to the terms and conditions set forth below:

1. **PROJECT:** The Project shall be performed at the entire cost and expense of Licensee, in accordance with good and sound engineering practices, to the satisfaction of CSXT’s Division Engineer or his or her duly authorized representative (“Division Engineer”) and in a manner to avoid accidents, damages, unnecessary delays to or interference with train traffic of CSXT. Prior to entry, Licensee shall notify the Division Engineer’s representative and arrange for flagging protection in accordance to Sections 5 and 6 of this Agreement. Licensee shall not dig in the ballast line or within the tracks loading influence area, or otherwise disturb the track structure. Licensee and Licensee’s employees, agents, contractors and other representatives (collectively, “Agents”) shall maintain in their possession a copy of this Agreement at all times during their occupation of the Property.

2. **INDEMNITY:**

2.1 Licensee hereby assumes risk of and agrees to indemnify, defend, protect and save CSXT and CSXT’s Affiliates harmless with respect to any and all attorneys’ fees, liability, claims, demands, payments, suits, actions, recoveries, penalties, costs, legal expenses, judgments, settlements, and damages of every nature, degree, and kind (including direct, indirect, consequential, incidental, and punitive damages) for:

- 2.1.1 personal injury, including, but not limited to bodily injury to or death of any person or persons whomsoever, including the agents, servants, Affiliates or employees of the parties;
- 2.1.2 the loss or damage to any property whatsoever, including property owned or in the care, custody or control of the parties hereto or their respective Affiliates;
- 2.1.3 any environmental damage and any related remediation brought or recovered against CSXT or any of its Affiliates; and
- 2.1.4 any and all other losses or damages; arising directly or indirectly from the presence of Licensee or its Agents on or about the Property, whether or not attributable in whole or part to the negligence, gross negligence, or intentional misconduct of CSXT or its Affiliates.

2.2 The parties waive any and all right or opportunity to contest the enforceability of this Section and agree that, in the event this Section, or any part of this Section, is found unenforceable by the final, unappealable judgment of a court of competent jurisdiction, this Section shall be construed so as to be enforceable to the maximum extent permitted by applicable law. In the event that such court of competent jurisdiction finds that Florida statutory construction contract indemnity monetary limits apply to this Agreement with respect to Licensee’s indemnification of CSXT and its Affiliates for liability caused in whole or in part by any act, omission or default by CSXT or its Affiliates, the parties hereto agree that such limit shall be equal to the limits (exclusive of deductibles) of the applicable insurance required by Sections 3 and 4 of this Agreement. The parties acknowledge and agree that this monetary limit, if required, bears a commercially reasonable relationship to this Agreement, in so far as, among other factors, the parties have taken into account the availability and cost of insurance and other risk transference devices, the scope of the Project, the risks associated with the Project, and the compensation and any other benefits exchanged between the parties in connection with this Agreement.

**2.2.1** Licensee shall comply with any federal, state, or local laws, statutes, codes, ordinances, rules, and regulations applicable to its presence or performance of any activity on the Property and agrees to indemnify, defend, and hold CSXT and its Affiliates harmless with respect to any fines, penalties, liabilities, or other consequences for its failure to so comply.

**2.2.2** For the purpose of this Agreement, the term "Affiliates" includes all entities, directly or indirectly owned or controlled by, or under common control of a party or its respective officers, directors, employees and agents, and in the case of CSXT, includes CSX Corporation, CSXT and their Affiliates and their respective officers, directors, employees and agents.

**2.2.3** The provisions of this Section shall survive the termination or expiration of this Agreement.

- 3. GENERAL LIABILITY INSURANCE:** Licensee shall procure and maintain, at its expense: (i) statutory Worker's Compensation and Employers Liability Insurance with available limits of not less than \$1,000,000.00, which insurance must contain a waiver of subrogation against CSXT and its Affiliates; (ii) Commercial General Liability coverage (inclusive of contractual liability) with available limits of not less than \$5,000,000.00 in combined single limits for bodily injury and property damage and covering the contractual liabilities assumed under this Agreement; (iii) business automobile liability insurance with available limits of not less than \$1,000,000.00 combined single limit for bodily injury and/or property damage per occurrence; and (iv) such other insurance as CSXT may reasonably require. Upon request, Licensee shall provide CSXT with a copy of Licensee's applicable insurance policies. A policy endorsement naming CSXT as an additional insured and specifying such coverage shall be furnished to CSXT prior to the execution of this Agreement, and the required coverage will be kept in force until all of Licensee's obligations under this Agreement have been fully discharged and fulfilled, or until Licensee shall have been specifically released by a written instrument signed by an authorized officer of CSXT. Licensee shall also provide CSXT with a copy of the insurance policies. The insurance policies shall provide that the insurance carrier must give CSXT notice at least thirty (30) days in advance of cancellation of coverage, of any change in coverage, or of cancellation of the policy. Notwithstanding any provisions of this Section, the liability assumed by Licensee shall not be limited to the required insurance coverage.
- 4. RAILROAD PROTECTIVE LIABILITY INSURANCE:** Licensee agrees to purchase Railroad Protective Liability Insurance in accordance with CSXT's requirements (attached as Exhibit A and incorporated into this Agreement) for the benefit of CSXT for Licensee's operations under this Agreement. Licensee shall furnish an appropriate Insurance policy (and required endorsements), as the case may be, with the return of this executed Agreement.
- 5. PRIOR NOTIFICATION:** Licensee or Licensee's Agents shall notify CSXT's Roadmaster at least 10 days prior to requiring entry on the Property and shall abide by the instructions of the Division Engineer, or his or her authorized representative. The Roadmaster, (\*\*\*\*), can be contacted at: (\*\*\*\*\*), to schedule flagging services.
- 6. CLEARANCES:** Neither Licensee nor Agents shall perform any Project or place or operate any equipment of Licensee or Agents at a distance closer than fifty (50) feet from the center of any track, without the prior approval of the Division Engineer. The Division Engineer may require protective services or such other services as deemed necessary or appropriate. Equipment shall be moved across CSXT's track(s) only at a public crossing unless prior arrangements have been made with the Division Engineer and a Private Crossing Agreement is fully executed and in place. Licensee and Agents shall take all precautions necessary to avoid interference with or damage to CSXT's property and signal and communication facilities during their performance of the Project.
- 7. PROTECTIVE SERVICES:** If protective services, such as flagging protection, are required by CSXT, Licensee shall make arrangements with the Roadmaster to furnish such personnel, flagman or watchman, that in the Roadmaster's opinion may be necessary to protect the facilities and traffic of CSXT during the performance of the Project. Licensee shall pay for the cost of such services, including all applicable surcharges and additives. These services are estimated to be \$\_\_\_\_\_, as supported by the attached estimate.
- 8. PAYMENT FOR PROTECTIVE SERVICES:** Payment shall be made by Licensee in accordance with the following designated option:
- ( ) **Option 1:** Licensee shall make an advance deposit of funds based on an estimate of the cost of protective or other services as determined by CSXT. The cost for CSXT's services shall then be assessed by CSXT against this advance deposit. Upon completion of the Project, any unused funding will be returned to Licensee. Notwithstanding the foregoing, in the event Licensee performs any Project work without permission or without protective services (such as flagging protection) as may be required by CSXT, no portion of Licensee's advance

deposit will be refunded. If CSXT's costs exceed the advance deposit(s), a request will be made to Licensee for additional funds or an invoice will be issued to Licensee for final payment. Licensee shall remit payment to CSXT within thirty (30) days of receipt of either a request for additional funds or an invoice.

( ) **Option 2:** Licensee shall promptly reimburse CSXT for the cost of protective or other services on an as-incurred basis, including all applicable surcharges, upon receipt of bill(s) therefor.

- 9. ENVIRONMENTAL:** This Agreement does not include and expressly excludes the performance of any site investigation activities designed to determine environmental conditions on, about or beneath the Property. Precluded activities include performing soil borings for purposes other than geotechnical investigation, obtaining soil, sediment, groundwater and surface water samples, and conducting field or laboratory analyses of any soil, sediment, groundwater or surface water samples obtained from CSXT property to identify chemical composition or environmental condition. *If any type of environmental investigation is desired, a separate right of entry agreement issued through CSXT's Environmental Department must be secured.*
- 10. CLAIMS:** Licensee shall, or shall require Agents, to promptly notify the Division Engineer of any loss, damage, injury or death arising out of or in connection with the Project.
- 11. REMEDIATION:** It is understood and agreed that, upon completion of the Project, the Property shall be left in a condition satisfactory to Division Engineer or his or her duly authorized representative.
- 12. SAFETY:**
- 12.1** All personnel entering the Property must comply with CSXT safety rules and requirements to include, without exception, the wearing of hard hats and approved safety shoes and safety glasses with side shields. Anyone not in compliance with these rules and regulations will be asked to leave the Property.
- 12.2** Before performing any work authorized by this Agreement, Licensee, at its sole cost and expense, shall obtain all necessary permit(s) (including but not limited to zoning, building, construction, health, safety or environmental matters), letter(s) or certificate(s) of approval. Licensee expressly agrees and warrants that it shall conform and limit its activities to the terms of such permit(s), approval(s) and authorization(s), and shall comply with all applicable ordinances, rules, regulations, requirements and laws of any governmental authority (state, federal or local) having jurisdiction over Licensee's activities, including the location, contact, excavation and protection regulations of the Occupational Safety and Health Act (OSHA) (29 CFR 1926.651(b), et al.), and State "One Call" -"Call Before You Dig" requirements.
- 13. TERM:** This Right-of-Entry Agreement and the permission conferred and the license granted by it does not constitute a grant of permanent easement and shall terminate upon completion of the Project or at midnight, \_\_\_\_\_, whichever occurs first, unless extended in writing by CSXT. In the event Licensee fails to comply with terms and provisions of this Agreement, Licensee agrees to pay and agrees that CSXT shall be entitled to recover costs and expenses incurred by CSXT, including legal fees and expenses, to enforce the terms of this Agreement.
- 14. SEVERABILITY:** The parties agree that if any part, term or provision of the Agreement is held to be illegal, unenforceable or in conflict with any applicable federal, state, or local law or regulation, such part, term or provision shall be severable, with the remainder of the Agreement remaining valid and enforceable. If any provision or any part of a provision of the Agreement shall be finally determined to be superseded, invalid, illegal, or otherwise unenforceable pursuant to any applicable law, ordinance, rule or regulation, such determination shall not impair or otherwise affect the validity, legality, or enforceability of the remaining provision or parts of the provision of the Agreement, which shall remain in full force and effect as if the unenforceable provision or part were deleted.
- 15. ENTIRE AGREEMENT:** This Agreement embodies the entire understanding of the parties, may not be waived or modified except in a writing signed by authorized representatives of both parties, and supersedes all prior or contemporaneous written or oral understandings, agreements or negotiations regarding its subject matter.
- 16. NOTICES:** All notices, consents and approvals required or permitted by this agreement shall be in writing and shall be deemed delivered; upon personal delivery, upon the expiration of three (3) business days following mailing by U.S. first class mail, or upon the next business day following mailing by a nationally recognized overnight carrier, to the Licensee at the address above, and to Licensor at the address shown on Page 1, or at such other addresses as either party may designate by delivery of prior notice to the other party .

- 17. **TERMINATION:** CSXT shall have the right at any time and at its sole discretion to terminate this Agreement upon notice to Licensee.
  
- 18. **WAIVER:** If either party fails to enforce its respective rights under this Agreement, or fails to insist upon the performance of the other party's obligations hereunder, such failure shall not be construed as a permanent waiver of any rights or obligations in this Agreement.
  
- 19. **GOVERNING LAW; VENUE:** This Agreement shall be governed by and construed under the laws of the State of Florida, without regard to the choice of law provisions thereof. Venue for any action arising from, or brought to enforce, this Agreement, shall vest exclusively in the state or federal courts located in Duval County, Florida, and the parties agree to submit to the personal jurisdiction of any state or federal court located in Duval County, Florida.
  
- 20. **NO ASSIGNMENT:** Notwithstanding anything to the contrary contained in this Agreement, Licensee shall not permit Agents to enter the Property without first requiring Agents to agree in writing to comply with all of the terms of this Agreement. Notwithstanding the foregoing, Licensee shall continue to be responsible for insuring that Agents comply with all of the terms and conditions of this Agreement and shall indemnify and hold CSXT harmless for any damages described in Section 2 above caused in whole or in part by such subcontractor. Assignment of this Agreement to any party other than Agents in accordance with this Section shall not be permitted except upon the prior written consent of CSXT, which consent may be granted or withheld at CSXT's sole discretion. This Agreement shall be binding upon the parties and their respective successors and assigns.

**IN WITNESS WHEREOF,** the parties hereto have caused this Agreement to be executed as of the day and year first above written.

**Witness for CSX Transportation:**

**CSX TRANSPORTATION, INC.**

\_\_\_\_\_

By: \_\_\_\_\_

Name:  
Title:

Witness for: (                    )

(                    ):

\_\_\_\_\_

By: \_\_\_\_\_

Print/Type Name: \_\_\_\_\_

Print/Type Title: \_\_\_\_\_

Who, by the execution hereof, affirms that he/she has the authority to do so and to bind the [\*] to the terms and conditions of this Agreement.

ATTACHMENT "A"  
**INSURANCE REQUIREMENTS**

**I. Insurance Policies:**

Agency and its Designee, if and to the extent that either is performing work on or about CSXT's property, shall procure and maintain the following insurance policies:

1. Commercial General Liability coverage at their sole cost and expense with limits of not less than \$5,000,000 in combined single limits for bodily injury and/or property damage per occurrence, and such policies shall name CSXT as an additional named insured. The policy shall include endorsement ISO CG 24 17 evidencing that coverage is provided for work within 50 feet of a railroad. If such endorsement is not included, railroad protective liability insurance must be provided as described in item 4 below.

2. Statutory Worker's Compensation and Employers Liability Insurance with limits of not less than \$1,000,000, which insurance must contain a waiver of subrogation against CSXT and its affiliates (if permitted by state law).

3. Commercial automobile liability insurance with limits of not less than \$1,000,000 combined single limit for bodily injury and/or property damage per occurrence, and such policies shall name CSXT as an additional named insured. The policy shall include endorsement ISO CA 20 70 evidencing that coverage is provided for work within 50 feet of a railroad. If such endorsement is not included, railroad protective liability insurance must be provided as described in item 4 below.

4. Railroad protective liability insurance with limits of not less than \$5,000,000 combined single limit for bodily injury and/or property damage per occurrence and an aggregate annual limit of \$10,000,000, which insurance shall satisfy the following additional requirements:

- a. The Railroad Protective Insurance Policy must be on the ISO/RIMA Form of Railroad Protective Insurance - Insurance Services Office (ISO) Form CG 00 35.
- b. CSX Transportation must be the named insured on the Railroad Protective Insurance Policy.
- c. Name and Address of Contractor and Agency must appear on the Declarations page.
- d. Description of operations must appear on the Declarations page and must match the Project description.
- e. Authorized endorsements must include the Pollution Exclusion Amendment - CG 28 31, unless using form CG 00 35 version 96 and later.
- f. Authorized endorsements may include:
  - (i). Broad Form Nuclear Exclusion - IL 00 21
  - (ii) 30-day Advance Notice of Non-renewal or cancellation
  - (iii) Required State Cancellation Endorsement
  - (iv) Quick Reference or Index - CL/IL 240
- g. Authorized endorsements may not include:
  - (i) A Pollution Exclusion Endorsement except CG 28 31
  - (ii) A Punitive or Exemplary Damages Exclusion
  - (iii) A "Common Policy Conditions" Endorsement
  - (iv) Any endorsement that is not named in Section 4 (e) or (f) above.
  - (v) Policies that contain any type of deductible

5. All insurance companies must be A. M. Best rated A- and Class VII or better.

6. The CSX OP number or CSX contract number, as applicable, must appear on each Declarations page and/or certificates of insurance.

7. Such additional or different insurance as CSXT may require.

## II. Additional Terms

1. Contractor must submit the complete Railroad Protective Liability policy, Certificates of Insurance and all notices and correspondence regarding the insurance policies in an electronic format to:

Insurance Department  
CSX Transportation, Inc.  
500 Water Street, C-907  
Jacksonville, FL 32202

OR

[insurancedocuments@csx.com](mailto:insurancedocuments@csx.com)

2. Neither Agency nor its Designee may begin work on or about CSXT property until written approval of the required insurance has been received from CSXT or CSXT's Insurance Compliance vendor, Ebix.

# APPENDIX

CSX Transportation

## RIGHT OF ENTRY AND INDEMNITY AGREEMENT FOR BRIDGE PAINTING (AESTHETIC)

Public Projects Group  
Jacksonville, FL  
Date Issued: July 2017

Project: **City, County, State** – Proposed **Project Description and location**; DOT #**123456A**; Milepost **xxx-123.45**; Division; Subdivision; OP \_\_\_\_\_

**RIGHT OF ENTRY AND INDEMNITY AGREEMENT**  
**FOR**  
**BRIDGE PAINTING (AESTHETIC)**

This Agreement is made and effective as of \_\_\_\_\_, by and between CSX TRANSPORTATION, INC., a Virginia corporation, with a mailing address of 500 Water Street, Jacksonville, Florida 32202, hereinafter called “**CSXT**,” and the Name of Agency, a public corporation, under the laws of the State of State, with a mailing address of Street Address, PO Box, City State and ZIP, hereinafter called “**AGENCY**”.

**WHEREAS**, CSXT controls and operates a right of way and bridge located within the \*\*\*\*\* Division, \*\*\*\*\* Subdivision, at DOT#: 123456A MP XXX-123.45. Street Name in City, County County, State (“the Property”);

WHEREAS, AGENCY has submitted a written request to enter the Property and to clean and paint the facing of the bridge (the “Project”) as described in Exhibit A, attached and incorporated by reference; and

**WHEREAS**, CSXT is willing to grant AGENCY the limited right and permission to enter upon the Property for the limited purpose of performing the Project;

**NOW, THEREFORE**, CSXT hereby grants to AGENCY the right and permission to enter upon the Property for the purpose of performing the Project, subject to the terms and conditions set forth below:

**1. TERM AND SCOPE**

From the period starting from the date of execution of this Agreement, through the date that is one year from such date unless further extended by mutual agreement of the parties (the “Term”), AGENCY, through its employees, agents, contractors, subcontractors, and/or other representatives (each, a “Designee” and collectively, “Designees”), may, only once (meaning not on a repetitive basis) enter the Property and perform the Project (the “Work”). Notwithstanding the foregoing, provided that CSXT shall first have approved the specifications therefore, as set forth in Section 2 hereof, AGENCY may also engage in periodic spot painting to remove graffiti (the “Spot Painting”).

**2. PROJECT**

A. All plans, specifications, drawings and other documents necessary or appropriate to the design and performance of the Project, including but not limited to paint color and temporary attachment specifications (if any), shall be prepared, at AGENCY’s sole cost and expense, by AGENCY or its Designees. Such plans shall be submitted to CSXT for review and approval of CSXT at least thirty (30) days prior to starting the Work or Spot Painting. The specifications for Spot Painting must include the paint color (which must be compatible with the most recent paint applied), application method (e.g. spray, brush, etc.), and structure access/reach equipment type (e.g. ladders, man lifts, etc.). CSXT may require paint removal prior to Spot Painting for safety reasons; if so, AGENCY must also submit a paint removal method (e.g. sand-blasting, chemical removal, etc.). **No Work or Spot Painting may begin until CSXT has approved the plans and specifications.** By its review or approval of plans pursuant to this Agreement, CSXT signifies only that such plans and performance of the Work and Spot Painting in accordance with such plans satisfy CSXT’s requirements.

B. Upon receipt of the specifications, CSXT’s authorized representative will determine and inform AGENCY whether a flagman need be present and whether AGENCY need implement any special protective or safety measures. If a flagman is required, AGENCY shall notify CSXT’s authorized representative and arrange for safety protection in accordance with this Agreement.

C. The Work and Spot Painting shall be performed in accordance with good and sound practices, to the satisfaction of CSXT’s authorized representative in a manner to avoid accidents, damages, unnecessary delays to or interference with the continuous and uninterrupted use of CSXT tracks or other operations, including train, signal, telephone and communication services, or damage to CSXT’s property, or to poles, wires, and other facilities of tenants on CSXT’s property or right-of-way. Under no circumstances shall Work or Spot Painting



Project: **City, County, State** – Proposed **Project Description and location**; DOT #**123456A**; Milepost **xxx-123.45**; Division; Subdivision; OP \_\_\_\_\_

affect the operations or safety of trains. If conditions arising from or in connection with the Project require that immediate and unusual provisions be made to protect train operation or CSXT's property, AGENCY shall make such provision.

D. The Project shall be designed and the Work and Spot painting performed at no cost, expense or liability to CSXT.

### **3. COMMENCEMENT OF WORK; AUTHORITY OF CSXT REPRESENTATIVE**

A. AGENCY shall not commence any Work on CSXT Property until AGENCY has:

1. Notified CSXT in writing of the date that it expects Work or Spot Painting to commence on the Project. Such notice must be received by CSXT at least ten (10) business days in advance of the date AGENCY proposes to begin Work or Spot Painting on the Property. The notice must refer to this Agreement by date.
2. Obtain authorization from CSXT's authorized representative to begin Work on CSXT property, such authorization to include an outline of specific conditions with which AGENCY must comply.

B. CSXT retains the paramount right to regulate all activities affecting its property and operations. CSXT's authorized representative shall have final authority in all matters affecting the safe maintenance of CSXT operations and CSXT property, and his or her approval shall be obtained by AGENCY for methods of construction to avoid interference with CSXT operations and CSXT property and all other matters contemplated by the Agreement.

### **4. FLAGGING / INSPECTION SERVICE**

A. CSXT has sole authority to determine the need for flagging required to protect its operations and property.

B. CSXT shall have the right to assign an individual to the site of the Project to perform inspection service whenever, in the opinion of CSXT's authorized representative, such inspection may be necessary.

C. Any CSXT expenses associated with flagging and inspection service shall be calculated, estimated, and reimbursed by AGENCY in the manner described in Section 10.

D. Should CSXT's authorized representative determine that flagging is necessary, AGENCY may attempt to coordinate the timing of the Work or Spot Painting with CSXT's authorized representative so that the Project may be performed during times that flagging is already ongoing at the Property.

### **5. SAFETY**

A. CSXT will provide AGENCY with a copy of its safety rules and requirements prior to the commencement of the Work or Spot Painting. Any AGENCY personnel or Designee entering the Property must comply with CSXT's safety rules and requirements. Anyone not in compliance with these rules and regulations will be asked to leave the Property.

B. Before performing any Work authorized by this Agreement, AGENCY, at no expense to CSXT, will obtain all necessary permit(s) (including, but not limited to, zoning, building, construction, health, safety or environmental matters), letter(s) or certificate(s) of approval. AGENCY expressly agrees and warrants that it shall conform and limit activities to the terms of such permit(s), approval(s) and authorization(s), and shall comply with all applicable ordinances, rules, regulations, requirements and laws of any governmental authority (state, federal or local) having jurisdiction over the activities in the Project, including applicable provisions of the Occupational Safety and Health Act (OSHA) (29 CFR 1926.651(b), et al.).

## **6. ACCESS LIMITATIONS; STORAGE OF MATERIALS**

A. This Agreement does not give AGENCY the right to cross CSXT property or tracks with vehicles, equipment or in any other matter other than at an existing and open public crossing. At no time will anyone performing the Work or Spot Painting be allowed beyond the bridge abutments on CSXT's property or be allowed on top of the bridge unless accompanied by CSXT personnel.

B. AGENCY shall not store materials or equipment on CSXT's property or where they may potentially interfere with CSXT's operations, unless AGENCY has received prior written permission from CSXT's authorized representative.

## **7. ENVIRONMENTAL**

A. This Agreement does not include and expressly excludes the performance of any site investigation activities designed to determine environmental conditions on, about or beneath the Property.

B. AGENCY shall comply with all federal, state and local environmental laws and regulations in its work at the Property and shall perform the Work or Spot Painting in an environmentally protective manner, and shall prevent releases and spills of any materials that could harm human health or the environment, including but not limited to, hydrocarbon products, anti-freeze, spent mechanical draining, solvents, hazardous substances and hazardous wastes as defined in the Comprehensive Environmental Response, Compensation and Liability Act and the Resource Conservation and Recovery Act, respectively ("Environmental Substances"). AGENCY, at its expense, shall assume all responsibility for the investigation and cleanup of any release or discharge of any Environmental Substance at the Property that arises from the performance of any work, presence or other activity at the Property by AGENCY or its Designees. In addition to other liability terms contained in this Agreement, AGENCY agrees to indemnify, defend and hold harmless CSXT and CSXT's Affiliates from and against all environmental costs and expenses, including without limitation, all environmental analysis and cleanup expenses, fines and claims, or penalties arising from any work, presence or activity of the AGENCY or its Designees at the Property.

## **8. REMEDIATION AND CLEAN-UP**

AGENCY, upon completion of the Work or Spot Painting, shall (i) remove from the Property any equipment, surplus materials, or rubbish belonging to AGENCY or AGENCY's Designee; and (ii) leave CSXT Property to its original condition, satisfactory to CSXT's authorized representative.

## **9. INSURANCE AND WAIVERS**

AGENCY shall (i) acquire or require AGENCY's Designee to purchase and maintain insurance in compliance with CSXT's insurance requirements attached to this Agreement as Exhibit B; (ii) require any individual not employed by AGENCY to execute the Waiver and Release Form attached hereto as Exhibit C; and (iii) require any Designee to execute the Acceptance by AGENCY Designee Form attached hereto as Exhibit D prior to entering CSXT property and/or commencing any Work or Spot Painting. Neither AGENCY nor AGENCY's Designee shall commence the Work or Spot Painting until such insurance policy or policies and forms have been submitted to and approved by CSXT's Risk Management Department.

## **10. CSXT'S COSTS AND EXPENSES; REIMBURSEMENT PROCEDURES**

A. **Reimbursable Expenses.** AGENCY shall reimburse CSXT or shall cause AGENCY's Designee to reimburse CSXT for all costs and expenses incurred by CSXT in connection with the Project, Work or Spot Painting (the "Reimbursable Expenses").

B. **Estimate.** CSXT has estimated the total Reimbursable Expenses as shown on Exhibit E (the "Estimate", as amended or revised). In the event CSXT anticipates that actual Reimbursable Expenses may exceed such Estimate, it shall provide AGENCY with the revised Estimate of the total Reimbursable Expenses.

C. **Payment Terms.** Upon execution and delivery of this Agreement by AGENCY, AGENCY will deposit with CSXT a sum equal to the estimated Reimbursable Expenses, as shown by the Estimate. Following completion of the

Project: **City, County, State** – Proposed **Project Description and location**; DOT #**123456A**; Milepost **xxx-123.45**; Division; Subdivision; OP \_\_\_\_\_

Project, CSXT shall submit to AGENCY a final invoice that reconciles the total costs incurred by CSXT against the total payments received from AGENCY. AGENCY shall pay to CSXT the amount by which expenses exceed total payments as shown by the final invoice, within thirty (30) days following delivery of such invoice to AGENCY. In the event that the payments received by CSXT from AGENCY exceed the estimated expenses, CSXT shall remit such excess to AGENCY.

## 11. INDEMNIFICATION.

A. As a material inducement for entering into this Agreement, and without which CSXT would not enter into the same, AGENCY covenants and agrees that to the extent permitted by law, AGENCY shall indemnify, defend, and hold CSXT and its affiliates harmless from and against all claims, demands, payments, suits, actions, judgments, settlements, and damages of every nature, degree, and kind (including direct, indirect, consequential, incidental, and punitive damages), for any injury to or death to any person(s) (including, but not limited to the employees of CSXT, its affiliates, AGENCY or its Designees), for the loss of or damage to any property whatsoever (including but not limited to property owned by or in the care, custody, or control of CSXT, its affiliates, AGENCY or its Designees), arising or resulting from the performance of this Agreement by AGENCY or any other person performing any work or service on the AGENCY's behalf on or about the Property. The foregoing indemnification obligation shall not be limited to the insurance coverage required by this Agreement, except to the extent required by law or otherwise expressly provided by this Agreement.

B. **Compliance with Laws.** AGENCY shall comply, and shall require its Designees to comply, with any federal, state, or local laws, statutes, codes, ordinances, rules, and regulations applicable to its construction and maintenance of the Project. AGENCY's Designees shall indemnify, defend, and hold CSXT and its affiliates harmless with respect to any fines, penalties, liabilities, or other consequences arising from breaches of this Section.

C. **"CSXT Affiliates"**. For the purpose of this Agreement, CSXT's affiliates include CSX Corporation and all entities, directly or indirectly, owned or controlled by or under common control of CSXT or CSX Corporation and their respective officers, directors, employees and agents.

D. **Survival.** The provisions of this Section shall survive the termination or expiration of this Agreement.

## 12. CLAIMS

AGENCY shall promptly notify the CSXT's authorized representative of any loss, damage, or injury arising out of or in connection with the Work or Spot Painting. AGENCY shall not create, permit or suffer any mechanic's or materialmen's liens of any kind or nature to be created or enforced against any property of CSXT for any such Work or Spot Painting performed.

## 13. MAINTENANCE

A. **By AGENCY.** Upon completion of the Project, AGENCY, or its Designee, shall be solely responsible for maintaining the aesthetic appearance of the Project, including taking any actions deemed necessary by CSXT, in its sole discretion, to address any damage or disfiguration due to vandalism or graffiti by Spot Painting, in accordance with Section 1. In the event AGENCY or its Designee fails to maintain the aesthetic appearance of the Project in a reasonable condition, as determined by CSXT in its sole discretion, CSXT, after due notice to AGENCY, may [(i) require AGENCY to remove or paint over the mural, (ii) at AGENCY Designee's sole cost and expense arrange for the mural to be removed or painted over, or (iii)] take such action as it deems appropriate to restore the railroad bridge to a condition acceptable to CSXT. For purposes of this Section, "due notice" shall mean thirty (30) days' notice unless CSXT, in its sole discretion, determines that an emergency condition exists, in which case, AGENCY or its Designee shall take immediate action.

B. **By CSXT.** CSXT shall not in any manner be restricted from (i) maintaining, repairing, replacing or renewing its tracks, all parts of the railroad bridge supports, signal and communication systems or any other rail facilities or its property as it deems appropriate or (ii) performing any actions required to reasonably support rail operations. Neither shall CSXT in any manner be responsible for any damage or disfiguration caused to the Project due to

Project: **City, County, State** – Proposed **Project Description and location**; DOT #**123456A**; Milepost **xxx-123.45**; Division; Subdivision; OP \_\_\_\_\_

such work, actions, or railroad operations, nor shall CSXT be responsible for the aesthetic appearance of the mural or the area of the railroad bridge supports upon which the Project is painted, so long as AGENCY remains responsible for the maintenance of the Project.

C. **Alterations.** AGENCY shall not undertake any alteration, modification or expansion of the Project, without the prior approval of CSXT, which may be withheld for any reason, and the execution of such agreements as CSXT may require.

#### **14. INDEPENDENT CONTRACTOR**

The parties agree that neither AGENCY nor the AGENCY Designee shall be deemed either agents or independent contractors of CSXT. Except as otherwise provided by this Agreement, CSXT shall exercise no control whatsoever over the employment, discharge, compensation of, or services rendered by AGENCY or AGENCY's Representative, or the construction practices, procedures, and professional judgment employed by AGENCY or AGENCY's Representative to complete the Project. Notwithstanding the foregoing, this Section shall in no way affect the absolute authority of CSXT to prohibit AGENCY or AGENCY's Representative or anyone from entering CSXT's property, or to require the removal of any person from its property, if it determines, in its sole discretion, that such person is not acting in a safe manner or that actual or potential hazards in, on or about the Property exist.

#### **15. INTERPRETATION**

AGENCY and CSXT each acknowledge that the terms, covenants, conditions, and provisions of this Agreement have been negotiated between and jointly authored by the parties hereto, and in consequence of this joint authorship, the parties agree that no term, covenant, condition or provision hereunder shall be construed more strictly against one party or the other hereto.

#### **16. SEVERABILITY**

The parties agree that if any part, term or provision of the Agreement is held to be illegal, unenforceable or in conflict with any applicable federal, state, or local law or regulation, such part, term or provision shall be severable, with the remainder of the Agreement remaining valid and enforceable. If any provision or any part of a provision of the Agreement shall be finally determined to be superseded, invalid, illegal, or otherwise unenforceable pursuant to any applicable law, ordinance, rule or regulation, such determination shall not impair or otherwise affect the validity, legality, or enforceability of the remaining provision or parts of the provision of the Agreement, which shall remain in full force and effect as if the unenforceable provision or part were deleted.

#### **17. ENTIRE AGREEMENT**

This Agreement embodies the entire understanding of the parties, may not be waived or modified except in a writing signed by authorized representatives of all parties, and supersedes all prior or contemporaneous written or oral understandings, agreements or negotiations regarding its subject matter. No modification or alteration of the terms hereof shall be binding unless such modification or alteration is in writing and executed by the parties.

#### **18. NOTICES**

All notices, consents and approvals required or permitted by this agreement shall be in writing and shall be deemed delivered; upon personal delivery, upon the expiration of three (3) business days following mailing by U.S. first class mail, or upon the next business day following mailing by a nationally recognized overnight carrier, to the parties at the addresses set forth below, or such other addresses as either party may designate by delivery of prior notice to the other party.

Project: City, County, State – Proposed Project Description and location; DOT #123456A; Milepost xxx-123.45; Division; Subdivision; OP \_\_\_\_\_

TO CSXT: CSX Transportation, Inc.  
500 Water Street, J301  
Jacksonville, Florida 32202  
Attention – Director Project Management, Public Projects

TO AGENCY: Name  
Title  
Agency  
Street Address  
City, State ZIP

## 19. TERMINATION

CSXT and AGENCY shall have the right to terminate this Agreement upon notice for any reason.

Termination of this Agreement or Work on the Project, for any reason, shall not diminish or reduce AGENCY’s obligation to pay CSXT for Reimbursable Expenses incurred in accordance with this Agreement. In the event of the termination of this Agreement or the Work for any reason, CSXT’s only remaining obligation to AGENCY shall be to refund to AGENCY payments made to CSXT in excess of Reimbursable Expenses in accordance with Section 10.

## 20. WAIVER

If any party fails to enforce its respective rights under this Agreement, or fails to insist upon the performance of the other party’s obligations hereunder, such failure shall in no way be construed as a permanent waiver of any rights or obligations in this Agreement, nor in any way to affect the validity of this Agreement or any part hereof or the right of either party to thereafter enforce each and every such provision and to exercise any such right or option. No waiver of any breach of this Agreement shall be held to be a waiver of any other or subsequent breach.

## 21. GOVERNING LAW; VENUE

This Agreement shall be governed by and construed under the laws of the State of Florida, without regard to the choice of law provisions thereof. Venue for any action arising from, or brought to enforce, this Agreement, shall vest exclusively in the state or federal courts located in Duval County, Florida, and the parties agree to submit to the personal jurisdiction of any state or federal court located in Duval County, Florida.

## 22. ASSIGNMENT

This Agreement shall be binding upon the parties hereto and upon all persons successor in interest to said parties. This Agreement shall not be assignable by AGENCY without the express written consent of CSXT.

**[SIGNATURE PAGE FOLLOWS]**

Project: City, County, State – Proposed Project Description and location; DOT #123456A; Milepost xxx-123.45; Division; Subdivision; OP \_\_\_\_\_

**IN WITNESS WHEREOF**, the parties have caused this Agreement to be executed as of the day and year first above written.

Agency

CSX TRANSPORTATION, INC.

\_\_\_\_\_  
Name / Title

\_\_\_\_\_

Date: \_\_\_\_\_

Name: Dale W. Ophardt  
Title: Assistant Vice President –  
Engineering  
Date: \_\_\_\_\_

APPROVED AS TO FORM AND LEGALITY:

\_\_\_\_\_  
AGENCY Attorney

Date: \_\_\_\_\_

Project: City, County, State – Proposed Project Description and location; DOT #123456A; Milepost xxx-123.45; Division;  
Subdivision; OP \_\_\_\_\_

EXHIBIT A  
PROJECT PLANS AND SPECIFICATIONS

## EXHIBIT B INSURANCE REQUIREMENTS

### I. Insurance Policies:

Agency and Contractor, if and to the extent that either is performing work on or about CSXT's property, shall procure and maintain the following insurance policies:

1. Commercial General Liability coverage at their sole cost and expense with limits of not less than \$5,000,000 in combined single limits for bodily injury and/or property damage per occurrence, and such policies shall name CSXT as an additional named insured. The policy shall include endorsement ISO CG 24 17 evidencing that coverage is provided for work within 50 feet of a railroad. If such endorsement is not included, railroad protective liability insurance must be provided as described in item 4 below.

2. Statutory Worker's Compensation and Employers Liability Insurance with limits of not less than \$1,000,000, which insurance must contain a waiver of subrogation against CSXT and its affiliates (if permitted by state law).

3. Commercial automobile liability insurance with limits of not less than \$1,000,000 combined single limit for bodily injury and/or property damage per occurrence, and such policies shall name CSXT as an additional named insured. The policy shall include endorsement ISO CA 20 70 evidencing that coverage is provided for work within 50 feet of a railroad. If such endorsement is not included, railroad protective liability insurance must be provided as described in item 4 below.

4. Railroad protective liability insurance with limits of not less than \$5,000,000 combined single limit for bodily injury and/or property damage per occurrence and an aggregate annual limit of \$10,000,000, which insurance shall satisfy the following additional requirements:

a. The Railroad Protective Insurance Policy must be on the ISO/RIMA Form of Railroad Protective Insurance - Insurance Services Office (ISO) Form CG 00 35.

b. CSX Transportation must be the named insured on the Railroad Protective Insurance Policy.

c. Name and Address of Contractor and Agency must appear on the Declarations page.

d. Description of operations must appear on the Declarations page and must match the Project description.

e. Authorized endorsements must include the Pollution Exclusion Amendment - CG 28 31, unless using form CG 00 35 version 96 and later.

f. Authorized endorsements may include:

- (i). Broad Form Nuclear Exclusion - IL 00 21
- (ii) 30-day Advance Notice of Non-renewal or cancellation
- (iii) Required State Cancellation Endorsement
- (iv) Quick Reference or Index - CL/IL 240

g. Authorized endorsements may not include:

- (i) A Pollution Exclusion Endorsement except CG 28 31
- (ii) A Punitive or Exemplary Damages Exclusion
- (iii) A "Common Policy Conditions" Endorsement
- (iv) Any endorsement that is not named in Section 4 (e) or (f) above.
- (v) Policies that contain any type of deductible

5. All insurance companies must be A. M. Best rated A- and Class VII or better.



Project: City, County, State – Proposed Project Description and location; DOT #123456A; Milepost xxx-123.45; Division; Subdivision; OP \_\_\_\_\_

6. The CSX OP number or CSX contract number, as applicable, must appear on each Declarations page and/or certificates of insurance.

7. Such additional or different insurance as CSXT may require.

## II. Additional Terms

1. Contractor must submit the original Railroad Protective Liability policy, Certificates of Insurance and all notices and correspondence regarding the insurance policies to:

Insurance Department  
CSX Transportation, Inc.  
500 Water Street, C-907  
Jacksonville, FL 32202

OR

insurancedocuments@csx.com

2. Neither Agency nor Contractor may begin work on the Project until it has received CSXT's written approval of the required insurance.

Project: City, County, State – Proposed Project Description and location; DOT #123456A; Milepost xxx-123.45; Division; Subdivision; OP \_\_\_\_\_

## EXHIBIT C

### WAIVER AND RELEASE FORM

### TEMPORARY LICENSE AGREEMENT

\_\_\_\_\_ shall indemnify and hold CSX Transportation, Inc. (“CSXT”), the owner or holder in interest of the tract of real property known as the CSX Transportation right of way under the \_\_\_\_\_, (the “Property”), harmless from all claims, damages, demands, causes of action, suits, expenses (including attorney’s fees and costs), judgments and interest whatsoever arising from a project to clean up and paint the bridge supports on the Property.

Signature: \_\_\_\_\_

Date: \_\_\_\_\_

Note: AGENCY must require any member, volunteer or other person not employed by AGENCY to execute this Waiver and Release Form, Exhibit C, prior to entering CSXT property and/or commencing any work on the Project. A copy of all Waiver and Release Forms obtained from any member, volunteer or other person not employed by AGENCY must be sent to:

Jonathan McArthur  
Risk Manager – Planning & Analysis  
CSX Transportation  
500 Water Street C-907  
Jacksonville, FL 32202  
Phone: 904-359-3394  
Fax: 904-306-5325

Project: **City, County, State** – Proposed **Project Description and location**; DOT #**123456A**; Milepost **xxx-123.45**; Division;  
Subdivision; OP \_\_\_\_\_

## EXHIBIT D

### ACCEPTANCE BY AGENCY DESIGNEE

To and for the benefit of CSX Transportation, Inc. ("CSXT") and to induce CSXT to permit the AGENCY Designee on or about CSXT's property for the purposes of performing Work or Spot Painting in accordance with the Agreement dated \_\_\_\_\_, 201\_\_, between AGENCY and CSXT, AGENCY Designee hereby agrees to abide by and perform all applicable terms of the Agreement, including, but not limited to Exhibit B and Exhibit C to the Agreement, and Sections 2, 3, 7, 8, 11, and 13 of the Agreement. Any notices required to be given to AGENCY Designee shall be in writing and delivered to the person identified below.

AGENCY Designee

By: \_\_\_\_\_

Print Name: \_\_\_\_\_

Title: \_\_\_\_\_

Date: \_\_\_\_\_

Notices shall be delivered to:

[name and address]

Project: City, County, State – Proposed Project Description and location; DOT #123456A; Milepost xxx-123.45; Division;  
Subdivision; OP \_\_\_\_\_

## EXHIBIT E

### ESTIMATE OF REIMBURSABLE EXPENSES

Attached

# APPENDIX

## CSX Transportation

### CSXT SPECIAL PROVISIONS

Public Projects Group  
Jacksonville, FL  
Date Issued: July 2017

## CSXT SPECIAL PROVISIONS

### **AUTHORITY OF CSXT ENGINEER**

The CSXT Representative shall have final authority in all matters affecting the safe maintenance of CSXT operations and CSXT property, and his or her approval shall be obtained by the Agency or its Contractor for methods of construction to avoid interference with CSXT operations and CSXT property and all other matters contemplated by the Agreement and these Special Provisions.

### **II. INTERFERENCE WITH CSXT OPERATIONS**

A. Agency or its Contractor shall arrange and conduct its work so that there will be no interference with CSXT operations, including train, signal, telephone and telegraphic services, or damage to CSXT's property, or to poles, wires, and other facilities of tenants on CSXT's Property or right-of-way. Agency or its Contractor shall store materials so as to prevent trespassers from causing damage to trains, or CSXT Property. Whenever Work is likely to affect the operations or safety of trains, the method of doing such Work shall first be submitted to the CSXT Representative for approval, but such approval shall not relieve Agency or its Contractor from liability in connection with such Work.

B. If conditions arising from or in connection with the Project require that immediate and unusual provisions be made to protect train operation or CSXT's property, Agency or its Contractor shall make such provision. If the CSXT Representative determines that such provision is insufficient, CSXT may, at the expense of Agency or its Contractor, require or provide such provision as may be deemed necessary, or cause the Work to cease immediately.

**III. NOTICE OF STARTING WORK.** Agency or its Contractor shall not commence any work on CSXT Property or rights of-way until it has complied with the following conditions:

A. Notify CSXT in writing of the date that it intends to commence Work on the Project. Such notice must be received by CSXT at least 10 business days in advance of the date Agency or its Contractor proposes to begin Work on CSXT property. The notice must refer to this Agreement by date. If flagging service is required, such notice shall be submitted at least thirty (30) business days in advance of the date scheduled to commence the Work.

B. Obtain authorization from the CSXT Representative to begin Work on CSXT property, such authorization to include an outline of specific conditions with which it must comply.

C. Obtain from CSXT the names, addresses and telephone numbers of CSXT's personnel who must receive notice under provisions in the Agreement. Where more than one individual is designated, the area of responsibility of each shall be specified.

### **IV. WORK FOR THE BENEFIT OF THE CONTRACTOR**

A. No temporary or permanent changes to wire lines or other facilities (other than third party fiber optic cable transmission systems) on CSXT property that are considered necessary to the Work are anticipated or shown on the Plans. If any such changes are, or become, necessary in the opinion of CSXT or Agency, such changes will be covered by appropriate revisions to the Plans and by preparation of a force account estimate. Such force account estimate may be initiated by either CSXT or Agency, but must be approved by both CSXT and Agency. Agency or Contractor shall be responsible for arranging for the relocation of the third party fiber optic cable transmission systems, at no cost or expense to CSXT.

B. Should Agency or Contractor desire any changes in addition to the above, then it shall make separate arrangements with CSXT for such changes to be accomplished at the Agency or Contractor's expense.

### **V. HAUL ACROSS RAILROAD**

A. If Agency or Contractor desires access across CSXT property or tracks at other than an existing and open public road crossing in or incident to construction of the Project, the Agency or Contractor must first obtain the permission of CSXT and shall execute a license agreement or right of entry satisfactory to CSXT, wherein Agency or Contractor agrees to bear all costs and liabilities related to such access.

B. Agency and Contractor shall not cross CSXT's property and tracks with vehicles or equipment of any kind or character, except at such crossing or crossings as may be permitted pursuant to this section.

## **VI. COOPERATION AND DELAYS**

A. Agency or Contractor shall arrange a schedule with CSXT for accomplishing stage construction involving work by CSXT. In arranging its schedule, Agency or Contractor shall ascertain, from CSXT, the lead time required for assembling crews and materials and shall make due allowance therefor.

B. Agency or Contractor may not charge any costs or submit any claims against CSXT for hindrance or delay caused by railroad traffic; work done by CSXT or other delay incident to or necessary for safe maintenance of railroad traffic; or for any delays due to compliance with these Special Provisions.

C. Agency and Contractor shall cooperate with others participating in the construction of the Project to the end that all work may be carried on to the best advantage.

D. Agency and Contractor understand and agree that CSXT does not assume any responsibility for work performed by others in connection the Project. Agency and Contractor further understand and agree that they shall have no claim whatsoever against CSXT for any inconvenience, delay or additional cost incurred by Agency or Contractor on account of operations by others.

## **VII. STORAGE OF MATERIALS AND EQUIPMENT**

Agency and Contractor shall not store their materials or equipment on CSXT's property or where they may potentially interfere with CSXT's operations, unless Agency or Contractor has received CSXT Representative's prior written permission. Agency and Contractor understand and agree that CSXT will not be liable for any damage to such materials and equipment from any cause and that CSXT may move, or require Agency or Contractor to move, such material and equipment at Agency's or Contractor's sole expense. To minimize the possibility of damage to the railroad tracks resulting from the unauthorized use of equipment, all grading or other construction equipment that is left parked near the tracks unattended by watchmen shall be immobilized to the extent feasible so that it cannot be moved by unauthorized persons.

## **VIII. CONSTRUCTION PROCEDURES**

### **A. General**

1. Construction work on CSXT property shall be subject to CSXT's inspection and approval.
2. Construction work on CSXT property shall be in accord with CSXT's written outline of specific conditions and with these Special Provisions.
3. Contractor shall observe the terms and rules of the CSXT Safe Way manual, which Agency and Contractor shall be required to obtain from CSXT, and in accord with any other instructions furnished by CSXT or CSXT's Representative.

### **B. Blasting**

1. Agency or Contractor shall obtain CSXT Representative's and Agency Representative's prior written approval for use of explosives on or adjacent to CSXT property. If permission for use of explosives is granted, Agency or Contractor must comply with the following:
  - a. Blasting shall be done with light charges under the direct supervision of a responsible officer or employee of Agency or Contractor.
  - b. Electric detonating fuses shall not be used because of the possibility of premature explosions resulting from operation of two-way train radios.
  - c. No blasting shall be done without the presence of an authorized representative of CSXT. At least 30 days' advance notice to CSXT Representative is required to arrange for the presence of an authorized CSXT representative and any flagging that CSXT may require.

d. Agency or Contractor must have at the Project site adequate equipment, labor and materials, and allow sufficient time, to (i) clean up (at Agency's expense) debris resulting from the blasting without any delay to trains; and (ii) correct (at Agency's expense) any track misalignment or other damage to CSXT's property resulting from the blasting, as directed by CSXT Representative, without delay to trains. If Agency's or Contractor's actions result in delay of any trains, including Amtrak passenger trains, Agency shall bear the entire cost thereof.

e. Agency and Contractor shall not store explosives on CSXT property.

2. CSXT Representative will:

a. Determine the approximate location of trains and advise Agency or Contractor of the approximate amount of time available for the blasting operation and clean-up.

b. Have the authority to order discontinuance of blasting if, in his or her opinion, blasting is too hazardous or is not in accord with these Special Provisions.

## **IX. MAINTENANCE OF DITCHES ADJACENT TO CSXT TRACKS**

Agency or Contractor shall maintain all ditches and drainage structures free of silt or other obstructions that may result from their operations. Agency or Contractor shall provide erosion control measures during construction and use methods that accord with applicable state standard specifications for road and bridge construction, including either (1) silt fence; (2) hay or straw barrier; (3) berm or temporary ditches; (4) sediment basin; (5) aggregate checks; and (6) channel lining. All such maintenance and repair of damages due to Agency's or Contractor's operations shall be performed at Agency's expense.

## **X. FLAGGING / INSPECTION SERVICE**

A. CSXT has sole authority to determine the need for flagging required to protect its operations and property. In general, flagging protection will be required whenever Agency or Contractor or their equipment are, or are likely to be, working within fifty (50) feet of live track or other track clearances specified by CSXT, or over tracks.

B. Agency shall reimburse CSXT directly for all costs of flagging that is required on account of construction within CSXT property shown in the Plans, or that is covered by an approved plan revision, supplemental agreement or change order.

C. Agency or Contractor shall give a minimum of 30 days' advance notice to CSXT Representative for anticipated need for flagging service. No work shall be undertaken until the flag person(s) is/are at the job site. If it is necessary for CSXT to advertise a flagging job for bid, it may take up to 90-days to obtain this service, and CSXT shall not be liable for the cost of delays attributable to obtaining such service.

D. CSXT shall have the right to assign an individual to the site of the Project to perform inspection service whenever, in the opinion of CSXT Representative, such inspection may be necessary. Agency shall reimburse CSXT for the costs incurred by CSXT for such inspection service. Inspection service shall not relieve Agency or Contractor from liability for its Work.

E. CSXT shall render invoices for, and Agency shall pay for, the actual pay rate of the flagpersons and inspectors used, plus standard additives, whether that amount is above or below the rate provided in the Estimate. If the rate of pay that is to be used for inspector or flagging service is changed before the work is started or during the progress of the work, whether by law or agreement between CSXT and its employees, or if the tax rates on labor are changed, bills will be rendered by CSXT and paid by Agency using the new rates. Agency and Contractor shall perform their operations that require flagging protection or inspection service in such a manner and sequence that the cost of such will be as economical as possible.

## **XI. UTILITY FACILITIES ON CSXT PROPERTY**

Agency shall arrange, upon approval from CSXT, to have any utility facilities on or over CSXT Property changed as may be necessary to provide clearances for the proposed trackage.



## **XII. CLEAN-UP**

Agency or Contractor, upon completion of the Project, shall remove from CSXT's Property any temporary grade crossings, any temporary erosion control measures used to control drainage, all machinery, equipment, surplus materials, falsework, rubbish, or temporary buildings belonging to Agency or Contractor. Agency or Contractor, upon completion of the Project, shall leave CSXT Property in neat condition, satisfactory to CSXT Representative.

## **XIII. FAILURE TO COMPLY**

If Agency or Contractor violate or fail to comply with any of the requirements of these Special Provisions, (a) CSXT may require Agency and/or Contractor to vacate CSXT Property; and (b) CSXT may withhold monies due Agency and/or Contractor; (c) CSXT may require Agency to withhold monies due Contractor; and (d) CSXT may cure such failure and the Agency shall reimburse CSXT for the cost of curing such failure.

# **APPENDIX**

**CSX Transportation**

## **OVERHEAD BRIDGE CRITERIA**

Office of Director Fixed Plant Engineering  
Jacksonville, FL  
Date Issued: July 2017

## CRITERIA FOR OVERHEAD BRIDGES

CSX Transportation (CSXT) has minimum requirements for outside parties constructing, rehabilitating, or replacing bridges over CSXT's railroad tracks. These requirements are intended to provide safe and continuous passage of all train traffic during and after construction of bridges over its tracks. Part of these requirements is for the outside party to submit a detailed plan of the project as well as provide details of the construction methodology. This document provides information on the requirements by CSXT for overhead bridges.

Plans and specifications for new or reconstructed bridges over CSXT's railroad tracks or right-of-way shall meet the following requirements:

### I. GENERAL REQUIREMENTS:

- A. CSXT's valuation station and the distance from the nearest milepost at the intersection of the centerline of the track and the centerline of the bridge shall be shown on the General Plan.
- B. The existing and proposed minimum horizontal and vertical clearances shall be marked clearly on the General Plan and Elevation.
- C. At least one subsurface exploration boring for each substructure unit adjacent to the track shall be furnished to CSXT's during the design submittal. Borings shall provide enough information to design shoring and foundations.
- D. Prior to construction activities, all overhead bridge projects will require the procurement of the appropriate property rights from Real Estate and Facilities Management (REFM) and other construction agreement(s) with CSX Transportation.
- E. All lifting equipment and connection devices shall have capacity for 150% of the actual lifting load. The factor of safety provided by the manufacturer in the lifting capacity data shall not be considered in the 150% requirement. A licensed professional engineer, familiar with lifting and rigging, in the State where the construction work is proposed must sign and seal all plans and calculations related to critical lifting on the project.

### II. CLEARANCES:

- A. Horizontal Clearance: Standard horizontal clearance from centerline of the track to the face of the pier or abutment shall typically be 25'-0" or greater, but never less than 18'-0", measured perpendicular to the track. Provisions for future tracks, access roads, other CSXT facilities, and drainage may require the minimum clearance be increased or use of multi-span structures. The toe of footings shall not be closer than 11'-0" from centerline of the track to provide adequate room for sheeting.
- B. Vertical Clearance: A standard vertical clearance of 23'-0" shall be provided, measured from top of high rail to lowest point of structure in the horizontal clearance area which extends 6'-0" either side of the centerline of track.
- C. Temporary Construction clearances to be used shall be subject to approval by CSXT. Typically reductions in clearance for construction are not permitted.
- D. CSXT shall be furnished as-built drawings showing actual clearances as constructed.

### III. CRASHWALLS:

AREMA Specifications, Chapter 8, Article 2.1.5 covers the requirements for crashwalls. Crashwalls are required when face of the pier is closer than 25'-0" from centerline of the track, measured perpendicular to the track, except as noted below.

Crashwalls shall meet the following requirements:

- A. Crashwalls for single column piers shall be minimum 2'-6" thick and shall extend a minimum of 6'-0" above the top of high rail for piers located between 18'-0" and 25'-0" from the centerline of the nearest track. The wall shall extend minimum 6'-0" beyond the column on each side in the direction parallel to the track.
- B. For multi-column piers, the columns shall be connected with a wall of the same thickness as the columns or 2'-6"

whichever is greater. The wall shall extend a minimum of 2'-6" beyond the end of outside columns in a direction parallel to the track.

C. Reinforcing steel to adequately anchor the crashwalls to the column and footing shall be provided. For piers of heavy construction, crashwalls may be omitted. Solid piers with a minimum thickness of 2'-6" and length of 20'-0", single column piers of minimum 4'-0" X 12'-6" dimensions or any other solid pier sections with equivalent cross sections and minimum 2'-6" thickness are considered as heavy construction.

#### IV. DRAINAGE:

Drainage from the bridge shall be preferably collected with drain pipes and drained away from CSXT's right-of-way. When open scuppers are provided on the bridge, none shall be closer than 25'-0" of the centerline of nearest track. Flow from the scuppers shall be directed away from CSXT's drainage ditches.

Projects including stormwater systems shall be designed for a 100-year storm event as a minimum. If stormwater is drained on or to CSXT's right-of-way, calculations must be submitted to CSXT to verify the 100-year storm event is properly handled. Improvements to the adjacent drainage systems may be required at project expense, to ensure the impacted system will meet the 100-year storm event minimum condition.

During and after completion of construction, the outside party or its contractor must clear CSXT's drainage ditches of all debris to the satisfaction of CSXT's construction engineering and inspection representative.

#### V. PROTECTIVE FENCING:

All highway structures shall have a protective barrier fence to extend at least 8'-0" from the top of the sidewalk or driving surface adjacent to the barrier wall. The fence may be placed on top of the barrier wall. The fence shall be capable of preventing pedestrians from dropping debris onto CSXT's right-of-way, and in particular, passing trains.

Openings in the fence shall not exceed 2" x 2". Fencing should also include anti-climbshields or be of a configuration to minimize the likelihood of climbing on the outside of the protective fencing. A chain link fence option is shown below:

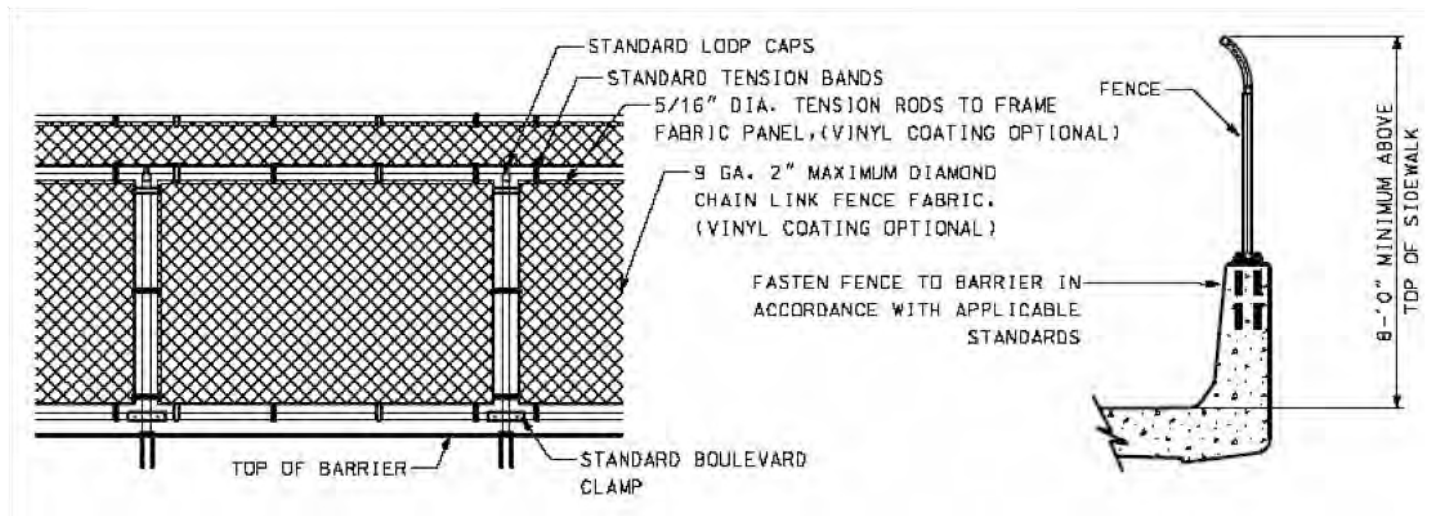

## **VI. STRUCTURE EXCAVATION AND SHORING:**

Shoring protection shall be provided when excavating adjacent to an active track. Shoring will be provided in accordance with *AREMA Manual for Railway Engineering* Chapter 8 part 28, except as noted below.

Shoring will not be required if both the following conditions are satisfied:

1. Excavation does not encroach upon a 1 horizontal to 1 vertical theoretical slope line starting at bottom corner of tie (live load influence zone).
2. Track is on level ground or in a cut section and on stable soil.

When the track is on an embankment, excavating the toe of the embankment without shoring may affect the stability of the embankment. Therefore, excavation of the embankment toe without shoring will not be permitted.

Preferred protection is the cofferdam type that completely encloses the excavation. Where dictated by conditions, partial cofferdams with open sides away from the track may be used. Cofferdams shall be constructed using steel sheet piling or steel soldier piles with timber lagging. Wales and struts shall be provided as needed. The following shall be considered when designing cofferdams:

- a. Shoring shall be designed to resist a vertical live load surcharge of 1,882 lbs. per square foot, in addition to active earth pressure. The surcharge shall be assumed to act on a continuous strip, 8'-6" wide. Lateral pressures due to surcharge shall be computed using the strip load formula shown in *AREMA Manual for Railway Engineering*, Chapter 8, Part 20.
- b. Allowable stresses in materials shall be in accordance with *AREMA Manual for Railway Engineering*, Chapter 7, 8, and 15.
- c. A construction procedure for temporary shoring shall be shown on the drawing.
- d. Safety railing shall be installed when temporary shoring is within 15'-0" of the centerline of the track.
- e. A minimum distance of 10 feet from centerline of the track to face of nearest point of shoring shall be maintained.

The contractor shall submit the following drawings and calculations for CSXT's review and approval.

1. Three (3) sets of detailed drawings of the shoring systems showing sizes of all structural members, details of connections, and distances from centerline of track to face of shoring. Drawing shall show a section showing height of shoring and track elevation in relation to bottom of excavation.
2. One set of calculations of the shoring design.

The drawings and calculations shall be prepared by a Licensed Professional Engineer in the State where shoring is to be constructed and shall bear his seal and signature. Shoring plans shall be approved by CSXT's construction engineering and inspection representative.

3. For sheeting and shoring within 18'-0" of the centerline of the track, the live load influence zone, and in slopes, the contractor shall use sheet pile. No sheet pile in slopes or within 18'-0" of the centerline of track shall be removed. Sheet piles shall be cut off 3'-0" below the finished ground line. The remaining 3'-0" shall be backfilled and compacted immediately after cut off.

## **VII. DEMOLITION OF EXISTING STRUCTURE:**

The Contractor shall submit a detailed procedure for demolition of existing structures over or adjacent to CSXT's tracks or right-of-way. The procedure shall clearly indicate the capacity of cranes, location of cranes with respect to the tracks and calculated lifting loads (refer to Section I.E of this document). The demolition procedure must be approved by CSXT's construction engineering and inspection representative.

CSXT's tracks, signals, structures, and other facilities shall be protected from damage during demolition of existing structure or replacement of deck slab. As a minimum, both of the following methods shall be used:

A. During demolition of the deck, a protection shield shall be erected from the underside of the bridge over the track area to catch falling debris. The protection shield shall be supported from girders or beams. The deck shall be removed by cutting it in sections and lifting each section out. The protection shield shall be designed, with supporting calculations, for a minimum of 50 pounds per square foot plus the weight of the equipment, debris, personnel, and other loads to be carried.

Large pieces of deck shall not be allowed to fall on the protection shield

B. A ballast protection system consisting of geofabric or canvas shall be placed over the track structure to keep the ballast clean. The system shall extend along the track structure for a minimum of 25'-0" beyond the limits of the demolition work, or farther if required by CSXT's construction engineering and inspection representative.

C. The Contractor shall submit detailed plans, with supporting calculations, of the protection shield and ballast protection systems for approval prior to the start of demolition.

D. Blasting will not be permitted to demolish a structure over or within CSXT's right-of-way.

### **VIII. ERECTION PROCEDURE:**

The Contractor shall submit a detailed procedure for erecting over or adjacent to CSXT's tracks or right-of-way. The procedure shall clearly indicate the capacity of cranes, location of cranes with respect to the tracks and calculated lifting loads (refer to Section. E of this document). The erection procedure must be approved by CSXT's construction engineering and inspection representative.

### **IX. PILE INSTALLATION:**

A. For the installation of piles and sheeting for abutment foundations, pier foundations, retaining wall foundations, temporary and permanent shoring and other structures on or adjacent to CSXT's right-of-way, the contractor may be required to submit a detailed track monitoring program for CSXT's approval prior to performing any work near CSXT's right-of-way.

B. The program shall specify the survey locations, the distance between the location points, and frequency of monitoring before, during, and after construction. CSXT shall have the capability of modifying the survey locations and monitoring frequency as needed during the project.

C. If any settlement is observed, CSXT's construction engineering and inspection representative shall be immediately notified. CSXT, at its sole discretion, shall have the right to immediately require all contractor operations to be ceased, have the excavated area immediately backfilled and/or determine what corrective action is required. Any corrective action required by CSXT or performed by CSXT including the monitoring of corrective action of the contractor will be at project expense.

### **X. PEDESTRIAN OVERHEAD:**

Pedestrian overhead bridges shall be governed by this document in its entirety with the following exceptions:

A. Pedestrian overhead bridges shall span the entire width of CSXT's right-of-way. Intermediate piers or other supports will not be permitted.

B. Pedestrian overhead bridges shall be completely enclosed with protective canopy or by other means to prevent users from dropping debris onto CSXT's right-of-way.

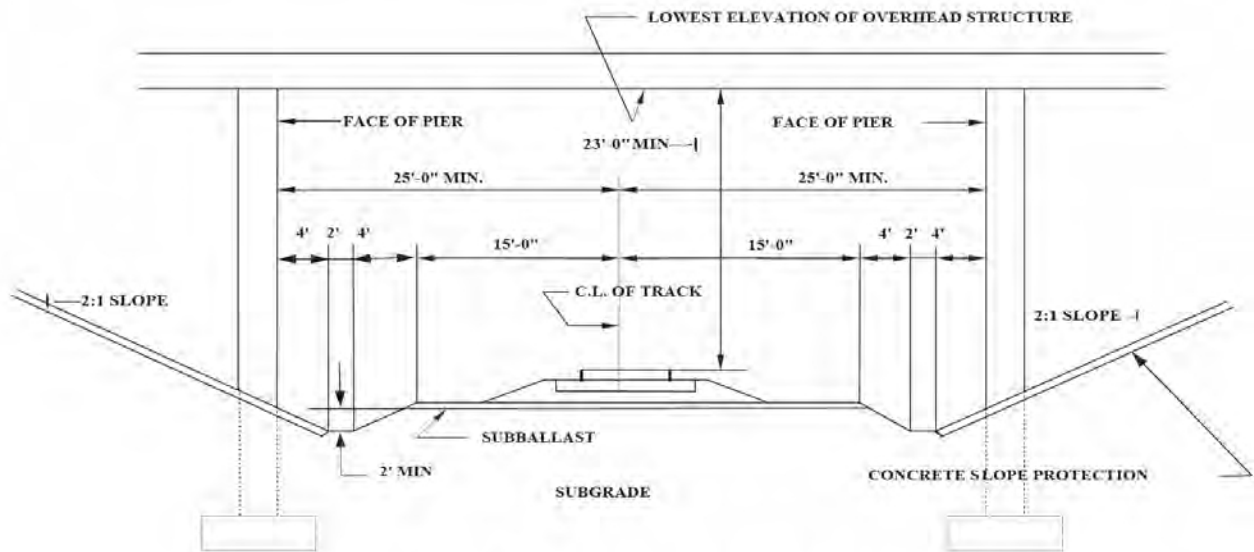

**CLEARANCES REQUIRED FOR OVERHEAD STRUCTURES  
TYPICAL ROADBED SECTION WITH STANDARD DITCHES**

**NOTE:** FOR MULTIPLE TRACKS, STANDARD TRACK CENTERS IS 15'-0". AN ADDITIONAL 8'-0" WIDE ACCESS ROAD MAY BE REQUIRED TO PROVIDE 33'-0" MINIMUM DISTANCE FROM CENTERLINE OF TRACK TO FACE OF PIER.

**CSX** ENGINEERING DEPARTMENT  
STANDARD CLEARANCES FOR OVERHEAD STRUCTURES

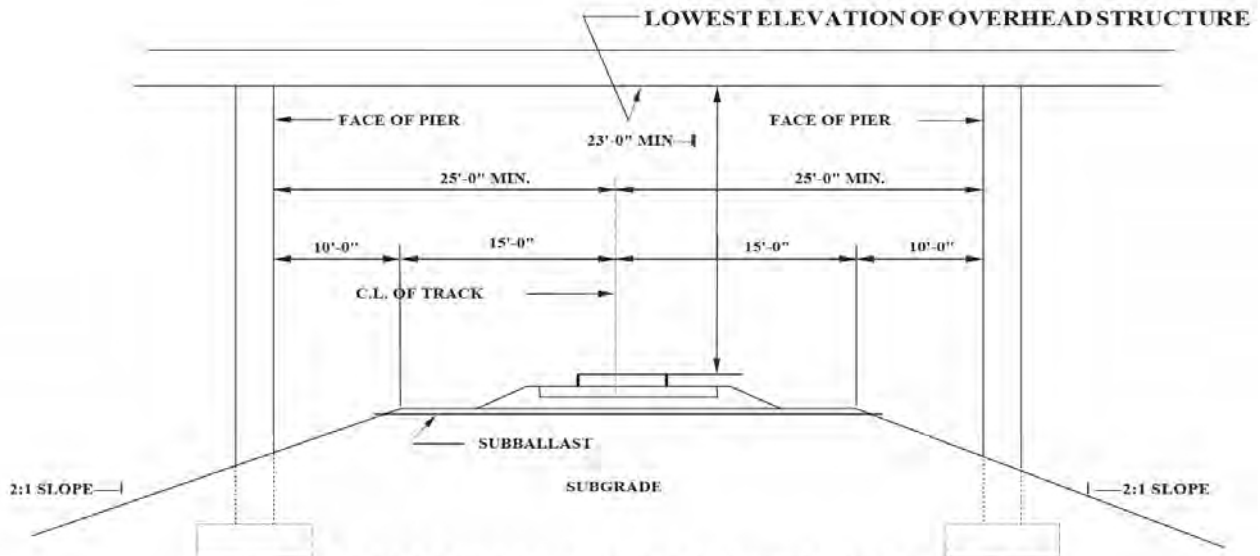

**CLEARANCES REQUIRED FOR OVERHEAD STRUCTURES  
TYPICAL SECTION FOR ROADBED IN FILL  
(WHERE NO DEFINED DITCHES ARE NEEDED)**

**CSX** ENGINEERING DEPARTMENT  
STANDARD CLEARANCES FOR OVERHEAD STRUCTURES

PROJECT: P 16274011 CSX TRACKS PROJECT (P) ELEM 161417 TRACKS (R) 0000 - 3000000 - CSX CONSTRUCTION CRITERIA MODIFICATIONS BUILDING

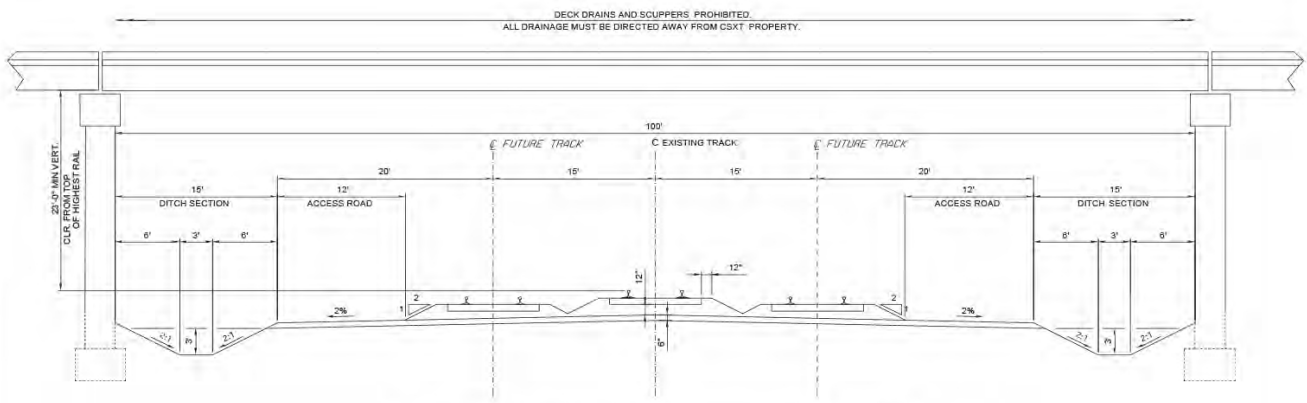

**TYPICAL TRACK CROSS SECTION FOR OVERHEAD BRIDGE DESIGNS**  
NTS

**NOTES:**

1. CLEAR SPAN WIDTH SHOULD ACCOUNT FOR THE NUMBER OF EXISTING TRACKS AT SPECIFIC PROJECT SITE. EACH ADDITIONAL TRACK ADDS 15' TO THE CLEAR SPAN WIDTH CALCULATION.
2. HORIZONTAL DIMENSIONS SHOWN ARE PERPENDICULAR TO C OF TRACK.
3. CRASHWALLS MAY BE REQUIRED BASED ON SITE SPECIFIC PARAMETERS.
4. ACTUAL REQUIRED HORIZONTAL CLEARANCES MAY NEED TO BE INCREASED DUE TO EXISTING ROADBED SECTION, LOCATION OF PARALLEL DITCHES, HYDROLOGICAL CONDITIONS, AND FUTURE TRACK REQUIREMENTS.
5. THEORETICAL TOE OF SLOPE IS BASED ON THE STANDARD ROADBED SECTION. ACTUAL TOE OF SLOPE MAY VARY DUE TO EXISTING GROUND LINE.
6. THE DITCH SECTION SHOWN IS THE MINIMUM ACCEPTABLE SECTION.
7. THE DITCH SECTION IS TO BE INCREASED AS REQUIRED BY LOCAL CONDITIONS, BASED ON HYDROLOGICAL AND HYDRAULIC STUDIES.
8. HORIZONTAL DIMENSIONS SHOWN ARE THE MINIMUM WHICH WILL ALLOW THE CONSTRUCTION OF CSX'S STANDARD ROADBED SECTION.

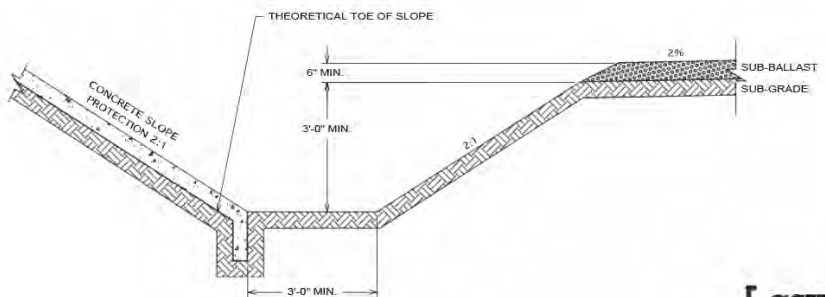

**DITCH DETAIL**  
NTS





# APPENDIX

CSX Transportation

## UNDERGRADE BRIDGE CRITERIA

Public Projects Group  
Jacksonville, FL  
Date Issued: July 2017

INTRODUCTION ..... 3

SECTION I: Definitions ..... 3

SECTION II: General Requirements ..... 4

SECTION III: Bridge Layout ..... 5

SECTION IV: Clearances ..... 5

SECTION V: Design Loads ..... 6

SECTION VI: Plan Preparation and Submittals ..... 7

SECTION VII: Material Requirements ..... 7

SECTION VIII: Construction Considerations ..... 8

SECTION IX: Bridge Decks ..... 8

SECTION X: Superstructure ..... 10

SECTION XI: Substructure ..... 10

# INTRODUCTION

The AREMA Manual for Railway Engineering shall serve as the overarching authority for recommended practice in designing CSXT railroad bridges. The intent of this document is to provide criteria which supplements, modifies and/or supersedes the applicable sections of the AREMA Manual for designing undergrade railway bridges which are to be owned and/or operated on by CSXT. Additionally, these requirements help guide an outside party through the necessary procedures for interacting with CSXT and delivering an acceptable structure that is constructible, inspectable, maintainable, long lasting, and reliable.

## I. DEFINITIONS

1. **Agency** – The project sponsor (i.e., State DOT, Provincial MOT, Local Agencies, Private Developer, etc.)
2. **AREMA** – American Railway Engineering and Maintenance-of-Way Association – the North American railroad industry standards group. The use of this term shall be in specific reference to the AREMA Manual for Railway Engineering.
3. **Construction Submission** – The Agency or its representative shall submit a digital copy of the project plans, supporting calculations, and detailed means and methods procedures for the specific proposed activity. All plans, specifications, and supporting calculations shall be signed and sealed by a Professional Engineer as defined below.
4. **Controlled Demolition** – Removal of an existing structure or subcomponents in a manner that positively prevents any debris or material from falling, impacting, or otherwise affecting CSXT employees, equipment or property. Provisions shall be made to ensure that there is no impairment of railroad operations or CSXT's ability to access its property at all times.
5. **Contractor** – The Agency's representative retained to perform the project work.
6. **Engineer** – CSXT Engineering Representative or a GEC authorized to act on the behalf of CSXT.
7. **Flagman** – A qualified CSXT employee with the sole responsibility to direct or restrict movement of trains, at or through a specific location, to provide protection for workers.
8. **GEC** – General Engineering Consultant who has been authorized to act on the behalf of CSXT.
9. **Horizontal Clearance** – Minimum distance measured perpendicularly from centerline of any track to the nearest obstruction at any elevation between TOR and the maximum vertical clearance of the track.
10. **Professional Engineer** – An engineer who is licensed in the Commonwealth, District, Province, or State in which the project is to occur. All plans, specifications, and supporting calculations shall be prepared under the direction of a Professional Engineer and shall bear their seal and signature.
11. **Potential to Foul** – Work having the possibility of impacting CSXT property or operations; defined as one or more of the following:
  - a. Any activity where access onto CSXT property is required.
  - b. Any activity where work is being performed on CSXT ROW.
  - c. Any excavation work adjacent to CSXT tracks or facilities, within the Theoretical Railroad Live Load Influence Zone, or where the active earth pressure zone extends within the CSXT property limits.
  - d. The use of any equipment where, if tipped and laid flat in any direction (360 degrees) about its center pin, can encroach within twenty five feet (25'-0") of the nearest track centerline. This is based upon the proposed location of the equipment during use, and may be a function of the equipment boom length. Note that hoisting equipment with the potential to foul must satisfy the 150% factor of safety requirement for lifting capacities.
  - e. Any work where the scatter of debris, or other materials has the potential to encroach within twenty five feet (25'-0") of the nearest track centerline.
  - f. Any work where significant vibration forces may be induced upon the track structure or existing structures located under, over, or adjacent to the track structure.
  - g. Any other work which poses the potential to disrupt rail operations, threaten the safety of railroad employees, or otherwise negatively impact railroad property, as determined by CSXT.

12. **ROW** – Right of Way; refers to all CSXT property and facilities, including all aerial and underground space within the property limits.
13. **Submission Review Period** – a minimum of 30 days in advance of start of work. Up to 30 days will be required for the initial review response. Up to an additional 30 days may be required to review any/all subsequent submissions or resubmission.
14. **Theoretical Railroad Live Load Influence Zone** – A 1 horizontal to 1 vertical theoretical slope line starting at bottom corner of tie.
15. **TOR** – Top of Rail. This is the base point for clearance measurements. It refers to the crown (top) of the steel rail; the point where train wheels bear on the steel rails. In superelevated track this refers to the higher of the two rails.
16. **Track Structure** – All load bearing elements supporting train loads. This includes, but is not limited to, the rail, ties, appurtenances, ballast, sub-ballast, embankment, retaining walls, and bridge structures.
17. **Vertical Clearance** – Distance measured from TOR to the lowest obstruction within six feet (6'-0") either side of the track centerline.

## II. GENERAL REQUIREMENTS

- A. Bridge shall be designed in accordance with the applicable specifications from the current edition of AREMA. Applicable sections may include, but are not limited to, the following:
 

Chapter 8	Concrete Structures and Foundations
Chapter 9	Seismic Design for Railway Structures
Chapter 15	Steel Structures
- B. Special Considerations
  1. AREMA recommendations for dampproofing and deck waterproofing (Chapter 8, Part 29). Additional requirements for waterproofing are provided in **Section IX BRIDGE DECKS** of this document.
  2. Painting of structural steel shall be performed in accordance with *CSXT Design and Construction Standard Specifications*. This document shall be supplemented by AREMA recommendations for shop painting steel (Chapter 15).
  3. Bridge shall be located to provide optimal railroad geometry.
- C. Construction Specifications
  1. *CSXT Design and Construction Standard Specifications* provide requirements for design, fabrication, and erection. This document shall be supplemented by AREMA recommendations for fabrication and erection.
  2. Items not covered by *CSXT Design and Construction Standard Specifications* shall be governed by applicable highway specifications from the Commonwealth, District, Province, or State where the bridge is being constructed.
  3. Reference *CSXT Construction Submission Criteria* for other construction considerations.
- D. Non-traditional bridge systems require written notice of acceptance by CSXT AVP Engineering. The proposed use of such a system shall be presented for review with thorough investigation, data, and detailed engineering justification.

### III. BRIDGE LAYOUT

- A. The general plan drawing of the bridge shall show the railroad valuation stations at the front face of backwalls, and centerline of piers or bents, along the centerline of the bridge. Distance from front face of low milepost backwall to low milepost nearest the bridge shall also be shown. The following criteria will serve as a guide for labeling the bridge layout.
  - 1. Railroad bridges are laid out in direction of increasing milepost, increasing from left to right on plans.
  - 2. Plans should denote the railroad direction and the nearest significant terminal or junction leading away from either end of the bridge.
  - 3. Substructures are numbered starting with zero and increasing in the direction of increasing mileposts
  - 4. Superstructures are numbered starting with 1 and increasing in the direction of increasing mileposts.
  - 5. Floor systems of thru plate girder, through truss, and deck truss spans are numbered starting with 0 and increasing in the direction of increasing mileposts.
  - 6. Bridge components are numbered from left to right facing the direction of increasing milepost.
- B. Low mile post backwall GPS coordinates shall be detailed on plans, in degrees-minutes-seconds, or decimal format with precision to six decimal places.
- C. For bridges on curves, the girders, abutments and piers shall be located with reference to chords.

### IV. CLEARANCES

- A. Under Bridge Vehicular Clearances
  - 1. Undergrade structures shall be designed to ensure that the structure will be protected from oversized or unauthorized loads by providing sufficient vertical clearance and protective devices. Provide a minimum vertical clearance over the entire roadway width for all new or reconstructed structures as follows:
    - i. 16'-6" for steel superstructure with 5 or more beams or 4 or more deck plate girders per track.
    - ii. 17'-6" for steel through plate girders or less than 4 deck plate girders per track with bolted bottom flanges.
    - iii. 20'-0" for steel through plate girders or less than 4 deck plate girders per track with welded bottom flanges.
    - iv. Concrete superstructures shall not be permitted over the entire roadway width.
    - v. Vertical clearance must not be violated due to the deflection of the superstructure.
  - 2. Roadway profile and design roadway vehicle information shall be provided and considered in vertical clearance design.
- B. Bridge Clearances
  - 1. Standard clearances on the bridge shall not be modified without written notice of approval by the CSXT AVP Engineering. Any proposed modification shall be furnished with detailed engineering justification for review.
  - 2. Commonwealth, District, Provincial, or State clearance laws must not be violated. Legal requirements must be upheld, unless written permission for waiver is provided by the appropriate regulatory authority.
  - 3. Adequate clearance and capacity shall be provided for a future track.
  - 4. Track centers shall not be closer than 15'-0".

5. Minimum horizontal clearance on the bridge shall be provided as shown below:

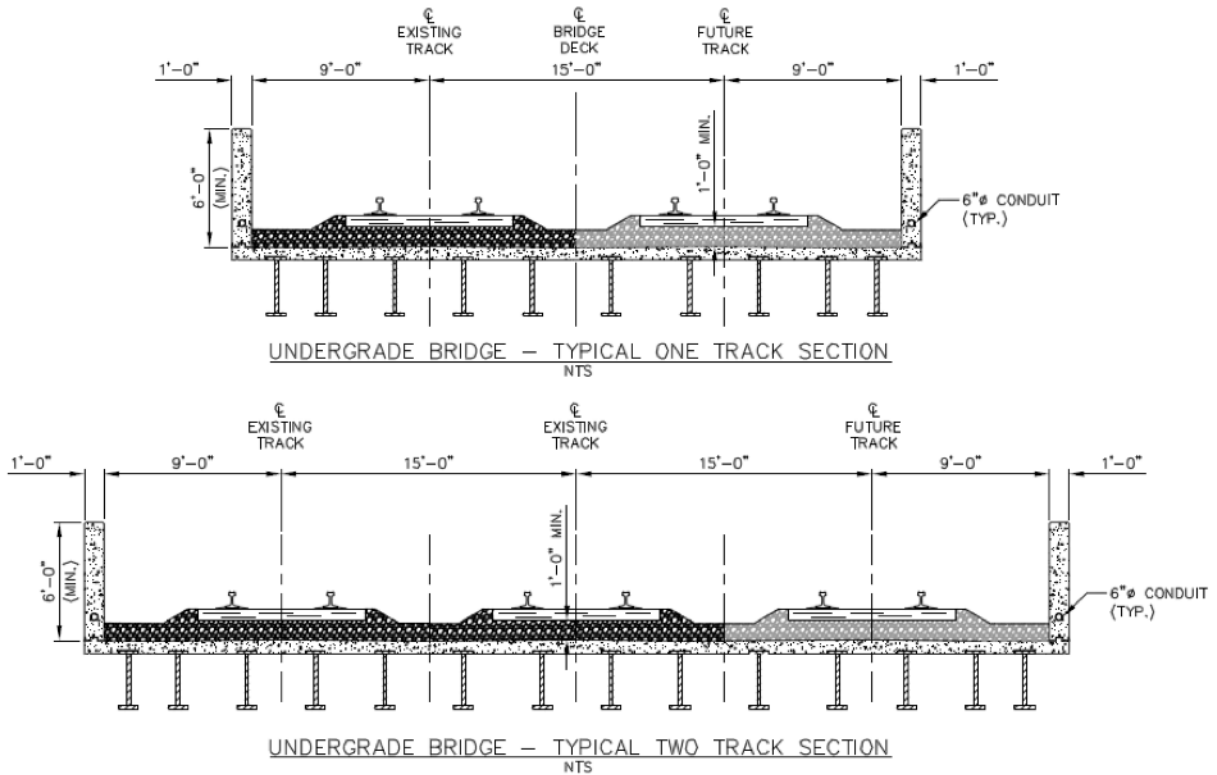

6. Standard clearances are for tangent track and increases must be provided to account for effects from curvature and superelevation as per CSX Standard Drawing 2604.

## V. DESIGN LOADS

- A. Railroad bridges shall be designed for all loads specified in AREMA.
- B. Live loads for steel structures shall consider both the Cooper E-90 loading and the Alternate Live Load with full diesel impact; whichever produces the greater stress. Live loads for concrete structures shall consider Cooper E-90 loading with full diesel impact.
- C. All bridges shall be designed with non-composite interaction between superstructure and deck. Mechanical connections shall be provided as necessary to satisfy design load requirements.
- D. The weight of the minimum ballast depth one foot (1'-0") plus an additional two feet (2'-0") of ballast below the tie shall be included when computing the dead load of the structure.

## VI. PLAN PREPARATION AND SUBMITTALS

- A. Preliminary Plans
  1. An electronic copy of type, size and location (TS&L) plans shall be submitted to CSXT for review and acceptance. The TS&L plan shall show plan view, elevation and typical cross section of the proposed structure. Railroad acceptance must be granted before proceeding with design.
  2. Furnish cross sections showing the AREMA Clearance Envelope, topographic map with contours, and soil exploration data along with TS&L plans. Railroad acceptance must be granted before proceeding with design.
- B. CSXT will assign a bridge designation when TS&L plans are reviewed. This bridge designation shall be shown on all drawings.
- C. Construction Work Plans
  1. CSXT may require construction work plans to be submitted, particularly when work is being performed in the proximity of an active track, with Potential to Foul.
  2. All construction work plans shall be submitted in accordance with the CSXT *Construction Submission Criteria*.

#### D. Material Submissions

1. Structural steel shop drawings shall be provided for CSXT review and acceptance, prior to ordering material. Welding procedures shall be submitted with the structural steel shop drawings.
2. Concrete mix designs shall be submitted for CSXT review and acceptance, prior to ordering material.
3. 3rd party testing reports shall be provided to CSXT for review and acceptance in a timely manner.
4. All other materials shall be provided in accordance with the plans. All materials shall be reviewed and approved by the Agency or its representative. Proposed changes are subject to review and acceptance by CSXT. Approved material submissions shall be furnished to CSXT for confirmation and project documentation.

#### E. Final Plans

1. Provide electronic set of final signed and sealed design plans and calculations for CSXT acceptance.
2. Submit special provisions or special specifications for CSXT acceptance.
3. Provide an electronic set of as-built plans to CSXT upon completion of construction. All Changes shall be noted and clearly called out on a redlined set of as-built plans. All pages shall be clearly marked "AS-BUILT", and include the date of completion.

### VII. MATERIAL REQUIREMENTS

All materials shall be in accordance with *CSXT Design and Construction Standard Specifications, Division 7 – Structures*.

### VIII. CONSTRUCTION CONSIDERATIONS

A. After construction contract is awarded, a copy of the contract shall be provided to CSXT.

#### B. Maintenance of railroad traffic

1. It is essential that the construction be performed with minimum interference to rail traffic. Continuity of safe rail operations will be required for the duration of the project.
2. The Agency's Design Engineer should contact the Public Project Manager in the preliminary design stage to determine railroad operational requirements. The most effective method of maintaining traffic is to temporarily reroute traffic around the construction site using detour tracks. Detour tracks will be required where feasible. If detour tracks cannot be provided, the new superstructure shall be constructed adjacent to final location and rolled into place. Construction plans shall show complete details of temporary bridges and/or roll-in structure.
3. A detailed construction procedure for maintaining traffic shall be shown on the plans. When construction requires total interruption of rail traffic, an estimate of the time required will be shown in the procedure. This interval must be within the approved time frame furnished by Public Project Manager.
4. Prior to the start of construction, written approval from the Railroad for the construction procedure must be secured.

### IX. BRIDGE DECKS

#### A. Walkways and Parapets

1. Deck shall be a uniform ballast pan across all tracks and provide for a ballast walkway between all tracks and on the field side of the exterior tracks. Intermediate curbs shall not be permitted.
  2. All exterior walkways shall utilize the uniform ballast pan and be equipped with a 72 inch tall parapet wall, measured from top surface of bridge deck. Parapet walls should include two each six inch ducts to accommodate signal and utility needs. Parapet walls shall be placed in accordance with Section IV. B.
  3. Walkways and parapets shall be designed to satisfy the requirements specified by AREMA.
- B. Minimum ballast depth shall be one foot (1'-0") measured from top of deck waterproofing to the bottom of tie, at the centerline of the low rail. This dimension shall be clearly labeled on cross section drawings.
- C. On bridges, timber crossties (7" x 9" x 8'6") shall be used, spaced at 20" centers. Alternatively, concrete crossties may be used also at 20" centers or steel crossties may be used at 24" centers.
- D. Track material shall be subject to review by CSXT or provided by CSXT at project expense.

#### E. Steel Deck Plates

1. Steel deck plates shall be shop welded with a pair of 5/16 inch continuous fillet welds to each floor beam or deck girder. Deck units shall be shop assembled with multiple beams per unit, and areas to be field welded shall be masked and field painted after welding is complete.
2. The closing deck plate between adjacent deck units shall be fillet welded to the beams with continuous 5/16 inch fillet welds at each beam. After deck plates are welded to the beam, fill space between deck plates at joint with material compatible with deck waterproofing membrane.
3. The minimum thickness of steel deck plates shall be as follows:

<u>Plate Thickness</u>	<u>Maximum Clear Distance Between Beams</u>
1/2 inch	1'-6"
5/8 inch	2'-0"
3/4 inch	2'-4"
4. For multiple deck girders with steel deck plates
  - i. Provide a welded field splice in the deck plate at, or near the centerline of bearing of the girders. Provide a closing deck plate from the abutments to this field splice that is normal to the girders and normal to the long direction of the main deck plates. This will avoid splicing deck plates over the back wall.
  - ii. Outside girders shall be spaced such that deck plates will not overhang the flange of the outside girders by more than 2 inches and a concrete parapet wall shall be provided. The wall shall be securely anchored to the deck girder and have a minimum width of 12 inches, at the top.

#### F. Concrete Decks

1. Bridge deck shall have adequate anchorage to the bridge superstructure. Shear studs shall not be permitted.
2. The outside edge of the slab shall be not more than 1'-6" from the centerline of the outside (fascia) girder.
3. Provide a drip edge on the outside edge, bottom face of the deck slab.

#### G. Deck Drainage & Waterproofing

1. Top surface of waterproofing protection shall have a minimum transverse slope of 1/8" per foot with a crown at centerline of the deck.
2. Top surface of waterproofing protection shall have a minimum longitudinal slope of 0.5%.
3. Concrete decks shall be designed and constructed to provide the required slopes and to direct water to deck drains.
4. When the deck is level or slopes less than 0.5%, underlayment is to be used to provide required slopes.
5. Deck drains shall be cast iron and downspouts shall be ductile iron. Deck drains shall have a grate or perforated cover. Downspouts shall be provided with cleanouts at each change in direction.
6. All bridge decks shall be waterproofed using membrane waterproofing.
7. All deck joints between spans shall be watertight.
8. Waterproofing shall be applied to the entire surface of deck and bottom three feet (3'-0") of inside faces of parapets or curb plates. Materials and construction to be in accordance with AREMA, Chapter 8.



## **X. SUPERSTRUCTURE**

- A. All bridges shall be comprised of simple spans. Continuous spans are prohibited and skewed spans are discouraged.
- B. Design shall provide accommodations for future maintenance. Jacking locations as well as jack sizing shall be specifically denoted and laid out in the bridge plans. Jacks shall be sized to accommodate full dead load including future ballast.
- C. Welded Plate Girders
  - 1. A full penetration groove weld shall be used for flange to web connection.
  - 2. No more than two flange section transitions will be permitted without special permission.
  - 3. When a lateral bracing system is required, as recommended by AREMA, girder connections shall be bolted.
  - 4. Jacking stiffeners are required at all end diaphragms. These locations must be specifically called out in the plans.
  - 5. Bearing stiffeners shall be welded or milled to bear for both top and bottom flanges.
  - 6. All cross frames shall be designed in accordance with AREMA recommendations.
- D. Through Plate Girders
  - 1. Through plate girder bridges are only permitted for double track bridges. The use of intermediate girders in double track applications will not be permitted.
  - 2. Floorbeam brackets (or knee braces) are stiffened diagonal plates which are bolted to the top flange of the floorbeams and to vertical stiffeners on the through girder and shall be designed to satisfy AREMA recommendations.
  - 3. All stringers shall frame into floorbeams.
  - 4. End floorbeams and connections shall be designed such that the bridge can be jacked up by placing jacks between the end floorbeams and pier or abutment. Jacking stiffeners shall be provided at points of jacking.
  - 5. Intermediate floorbeams shall frame into the girder web using double connection angles and high strength bolts.
  - 6. All Stringers shall have top and bottom flanges clipped at an angle not greater than 45 degrees to permit field removal and installation.

## **XI. SUBSTRUCTURE**

- A. Design shall provide accommodations for future maintenance. Jacking locations as well as jack sizing shall be specifically denoted and laid out in the bridge plans.
- B. Abutments and Wing Walls
  - 1. The abutment shall be designed in accordance with recommendations of AREMA, Chapter 8.
  - 2. The minimum abutment width shall be sufficient to provide for 15'-0" track centers, and standard road bed section.
  - 3. Wing walls shall be designed to support 2 horizontal to 1 vertical embankment slope as well as a level approach to the bridge walkways. MSE and sheet pile walls are not permissible.
  - 4. Provide minimum clearance necessary between end of structural steel and face of backwalls to accommodate expansion, but not less than two inches at each end.
  - 5. Provide keyways and water stops at all construction joints. Water stops shall be a hollow bulb PVC 9" X 3/8" (Bulb 3/4 inch inside diameter, 1 1/2 inch outside diameter) continuous across joint.
  - 6. Two feet of porous backfill, measured horizontally, shall be provided full height below subballast, behind all abutments and wing walls.

7. Provide adequate drainage behind abutments and wing walls utilizing perforated pipe drains at the base of the abutments and wingwalls. When abutment geometry does not allow for perforated pipe drains, weep holes may be required.
8. Non-perforated pipe shall be connected to the perforated pipe and drain away from the bridge with a 1% minimum slope.

C. Piers

1. Width of pier shall be minimum four feet (4'-0") width measured at the bearing seat.

# **APPENDIX**

**CSX Transportation**

## **CONSTRUCTION SUBMISSION CRITERIA**

Public Projects Group  
Jacksonville, FL  
Date Issued: April 14, 2015

## TABLE OF CONTENTS

### INTRODUCTION

SECTION I:	Definitions
SECTION II:	Construction Submissions
SECTION III:	Hoisting Operations
SECTION IV:	Demolition Procedure
SECTION V:	Erection Procedure
SECTION VI:	Temporary Excavation and Shoring
SECTION VII:	Track Monitoring

### INTRODUCTION

The intent of this document is to guide outside agencies and their Contractors when performing work on, over, or with potential to impact CSXT property (ROW). Work plans shall be submitted for review to the designated CSXT Engineering Representative for all work which presents the potential to affect CSXT property or operations; this document shall serve as a guide in preparing these work plans. All work shall be performed in a manner that does not adversely impact CSXT operations or safety; as such, the requirements of this document shall be strictly adhered to, in addition to all other applicable standards associated with the construction. Applicable standards include, but are not limited to, CSXT Standards and Special Provisions, CSXT Insurance Requirements, CSXT Pipeline Occupancy Criteria, as well as the governing local, county, state and federal requirements. It shall be noted that this document and all other CSXT standards are subject to change without notice, and future revisions will be made available at the CSXT website: [www.csx.com](http://www.csx.com).

### I. DEFINITIONS

1. *Agency* – The project sponsor (i.e., State DOT, Local Agencies, Private Developer, etc.)
2. *AREMA* – American Railway Engineering and Maintenance-of-Way Association – the North American railroad industry standards group. The use of this term shall be in specific reference to the AREMA Manual for Railway Engineering.
3. *Construction Submission* – The Agency or its representative shall submit six (6) sets of plans, supporting calculations, and detailed means and methods procedures for the specific proposed activity. All plans, specifications, and supporting calculations shall be signed/sealed by a Professional Engineer as defined below.
4. *Controlled Demolition* – Removal of an existing structure or subcomponents in a manner that positively prevents any debris or material from falling, impacting, or otherwise affecting CSXT employees, equipment or property. Provisions shall be made to ensure that there is no impairment of railroad operations or CSXT's ability to access its property at all times.
5. *Contractor* – The Agency's representative retained to perform the project work.
6. *Engineer* – CSXT Engineering Representative or a GEC authorized to act on the behalf of CSXT.
7. *Flagman* – A qualified CSXT employee with the sole responsibility to direct or restrict movement of trains, at or through a specific location, to provide protection for workers.
8. *GEC* – General Engineering Consultant who has been authorized to act on the behalf of CSXT.
9. *Horizontal Clearance* – Distance measured perpendicularly from centerline of any track to the nearest obstruction at any elevation between TOR and the maximum vertical clearance of the track.
10. *Professional Engineer* – An engineer who is licensed in State or Commonwealth in which the project is to occur. All plans, specifications, and supporting calculations shall be prepared by the Licensed Professional Engineer and shall bear his/her seal and signature.
11. *Potential to Foul* – Work having the possibility of impacting CSXT property or operations; defined as one or more of the following:
  - a. Any activity where access onto CSXT property is required.
  - b. Any activity where work is being performed on CSXT ROW.
  - c. Any excavation work adjacent to CSXT tracks or facilities, within the Theoretical Railroad Live Load Influence Zone, or where the active earth pressure zone extends within the CSXT property limits.
  - d. The use of any equipment where, if tipped and laid flat in any direction (360 degrees) about its center pin, can encroach within twenty five feet (25'-0") of the nearest track centerline. This is based upon the proposed location of

- the equipment during use, and may be a function of the equipment boom length. Note that hoisting equipment with the potential to foul must satisfy the 150% factor of safety requirement for lifting capacities.
- e. Any work where the scatter of debris, or other materials has the potential to encroach within twenty five feet (25'-0") of the nearest track centerline.
  - f. Any work where significant vibration forces may be induced upon the track structure or existing structures located under, over, or adjacent to the track structure.
  - g. Any other work which poses the potential to disrupt rail operations, threaten the safety of railroad employees, or otherwise negatively impact railroad property, as determined by CSXT.
12. *ROW – Right of Way*; Refers to CSXT Right-of-Way as well as all CSXT property and facilities. This includes all aerial space within the property limits, and any underground facilities.
  13. *Submission Review Period* - a minimum of thirty (30) days in advance of start of work. Up to thirty (30) days will be required for the initial review response. Up to an additional thirty (30) days may be required to review any/all subsequent submissions or resubmission.
  14. *Theoretical Railroad Live Load Influence Zone* – A 1 horizontal to 1 vertical theoretical slope line starting at bottom corner of tie.
  15. *TOR – Top of Rail*. This is the base point for clearance measurements. It refers to the crown (top) of the steel rail; the point where train wheels bear on the steel rails.
  16. *Track Structure* – All load bearing elements which support the train. This includes, but is not limited to, the rail, ties, appurtenances, ballast, sub-ballast, embankment, retaining walls, and bridge structures.
  17. *Vertical Clearance* – Distance measured from TOR to the lowest obstruction within six feet (6'-0") of the track centerline, in either direction.

## **II. GENERAL SUBMISSION REQUIREMENTS**

- A. A construction work plan is required to be submitted by the Agency or its Contractor, for review and acceptance, prior to accessing or performing any work with Potential to Foul.
- B. The Agency or its representative shall submit six (6) sets of plans, specifications, supporting calculations, and detailed means and methods procedures for the specific proposed work activity.
- C. Construction submissions shall include all information relevant to the work activity, and shall clearly and concisely explain the nature of the work, how it is being performed, and what measures are being taken to ensure that railroad property and operations are continuously maintained.
- D. All construction plans shall include a map of the work site, depicting the CSXT tracks, the CSXT right of way, proposed means of access, proposed locations for equipment and material staging (dimensioned from nearest track centerline), as well as all other relevant project information. An elevation drawing may also be necessary in order to depict clearances or other components of the work.
- E. Please note that CSXT will not provide pricing to individual contractors involved in bidding projects. Bidding contractors shall request information from the agency and not CSXT.
- F. The Contractor shall install a geotextile fabric ballast protection system to prevent construction or demolition debris and fines from fouling ballast. The geotextile ballast protection system shall be installed and maintained by the Contractor to the satisfaction of the Engineer.
- G. The Engineer shall be kept aware of the construction schedule. The Contractor shall provide timely communication to the Engineer when scheduling the work such that the Engineer may be present during the work. The Contractor's schedule shall not dictate the work plan review schedule, and flagging shall not be scheduled prior to receipt of an accepted work plan.

H. At any time during construction activities, the Engineer may require revisions to the previously approved procedures to address weather, site conditions or other circumstances that may create a potential hazard to rail operations or CSXT facilities. Such revisions may require immediate interruption or termination of ongoing activities until such time the issue is resolved to the Engineer's satisfaction. CSXT and its GEC shall not be responsible for any additional costs or time claims associated with such revisions.

I. Blasting will not be permitted to demolish a structure over or within CSXT's right-of-way. When blasting off of CSXT property but with Potential to Foul, vibration monitoring, track settlement surveying, and/or other protective measures may be required as determined by the Engineer.

J. Blasting is not permitted adjacent to CSXT right-of-way without written approval from the Chief Engineer, CSXT.

K. Mechanical and chemical means of rock removal must be explored before blasting is considered. If written permission for the use of explosives is granted, the Agency or Contractor must submit a work plan satisfying the following requirements:

1. Blasting shall be done with light charges under the direct supervision of a responsible officer or employee of the Agency or Contractor.
2. Electronic detonating fuses shall not be used because of the possibility of premature explosions resulting from operation of two-way train radios.
3. No blasting shall be done without the presence of an authorized representative of CSXT. Advance notice to the Engineer is required to arrange for the presence of an authorized CSXT representative and any flagging that CSXT may require.
4. Agency or Contractor must have at the project site adequate equipment, labor and materials, and allow sufficient time, to clean up debris resulting from the blasting and correct any misalignment of tracks or other damage to CSXT property resulting from the blasting. Any corrective measures required must be performed as directed by the Engineer at the Agency's or Contractor's expense without any delay to trains. If Agency's or Contractor's actions result in the delay of any trains including passenger trains, the Agency or Contractor shall bear the entire cost thereof.
5. The Agency or Contractor may not store explosives on CSXT property.
6. At any time during blasting activities, the Engineer may require revisions to the previously approved procedures to address weather, site conditions or other circumstances that may create a potential hazard to rail operations or CSXT facilities. Such revisions may require immediate interruption or termination of ongoing activities until such time the issue is resolved to the Engineer's satisfaction. CSXT and its GEC shall not be responsible for any additional costs or time claims associated with such revisions.

### **III. HOISTING OPERATIONS**

A. All proposed hoisting operations with Potential to Foul shall be submitted in accordance with the following:

1. A plan view drawing shall depict the work site, the CSXT track(s), the proposed location(s) of the lifting equipment, as well as the proposed locations for picking, any intermediate staging, and setting the load(s). All locations shall be dimensioned from centerline of the nearest track. Crane locations shall also be dimensioned from a stationary point at the work site for field confirmation.
2. Computations showing the anticipated weight of all picks. Computations shall be made based upon the field-verified plans of the existing structure. Pick weights shall account for the weight of concrete rubble or other materials attached to the component being removed; this includes the weight of subsequent rigging devices/components. Rigging components shall be sized for the subsequent pick weight.
3. All lifting equipment, rigging devices, and other load bearing elements shall have a rated (safe lifting) capacity that is greater than or equal to 150% of the load it is carrying, as a factor of safety. Supporting calculations shall be furnished to verify the minimum capacity requirement is maintained for the duration of the hoisting operation.

4. Dynamic hoisting operations are prohibited when carrying a load with the Potential to Foul. Cranes or other lifting equipment shall remain stationary during lifting. (i.e., no moving picks).
5. For lifting equipment, the manufacturer's capacity charts, including crane, counterweight, maximum boom angle, and boom nomenclature is to be submitted.
6. A schematic rigging diagram must be provided to clearly call out each rigging component from crane hook to the material being hoisted. Copies of catalog or information sheets shall be provided to verify rigging weights and capacities.
7. For built-up rigging devices, the contractor shall submit the following:
  - i. Details of the device, calling out material types, sizes, connections and other properties.
  - ii. Load test certification documents and/or design computations bearing the seal and signature of a Professional Engineer. Load test shall be performed in the configuration of its intended use as part of the subject demolition procedure.
  - iii. Copies of the latest inspection reports of the rigging device. The device shall be inspected within one (1) calendar year of the proposed date for use.
8. A detail shall be provided showing the crane outrigger setup, including dimensions from adjacent slopes or facilities. The detail shall indicate requirements for bearing surface preparation, including material requirements and compaction efforts. As a minimum, outriggers and/or tracks shall bear on mats, positioned on level material with adequate bearing capacity.
9. A complete written narrative that describes the sequence of events, indicating the order of lifts and any repositioning or re-hitching of the crane(s).

#### **IV. DEMOLITION PROCEDURE**

- A. The Agency or its Contractor shall submit a detailed procedure for a controlled demolition of any structure on, over, or adjacent to the ROW. The controlled demolition procedure must be approved by the Engineer prior to beginning work on the project.
- B. Existing Condition of structure being demolished:
  1. The Contractor shall submit as-built plans for the structure(s) being demolished.
  2. If as-built plans are unavailable, the Contractor shall perform an investigation of the structure, including any foundations, substructures, etc. The field measurements are to be made under the supervision of the Professional Engineer submitting the demolition procedure. Findings shall be submitted as part of the demolition means and methods submittal for review by the Engineer.
  3. Any proposed method for temporary stabilization of the structure during the demolition shall be based on the existing plans or investigative findings, and submitted as part of the demolition means and methods for review by the Engineer.
- C. Demolition work plans shall include a schematic plan depicting the proposed locations of the following, at various stages of the demolition:
  1. All cranes and equipment, calling out the operating radii.
  2. All proposed access and staging locations with all dimensions referenced from the center line of the nearest track.
  3. Proposed locations for stockpiling material or locations for truck loading.
  4. The location, with relevant dimensions, of all tracks, other railroad facilities; wires, poles, adjacent structures, or buried utilities that could be affected, showing that the proposed lifts are clear of these obstructions.
  5. Note that no crane or equipment may be set on the CSXT rails or track structure and no material may be dropped on CSXT property.
- D. Demolition submittal shall also include the following information:
  1. All hoisting details, as dictated by Section III of this document.
  2. A time schedule for each of the various stages must be shown as well as a schedule for the entire lifting procedure.

The proposed time frames for all critical subtasks (i.e., torch/saw cutting various portions of the superstructure or substructure, dismantling splices, installing temporary bracing, etc.) shall be furnished so that the potential impact(s) to CSXT operations may be assessed and eliminated or minimized.

3. The names and experience of the key Contractor personnel involved in the operation shall be included in the Contractor's means and methods submission.
  4. Design and supporting calculations shall be prepared, signed, and sealed by the Professional Engineer for items including the temporary support of components or intermediate stages shall be submitted for review. A guardrail will be required to be installed in a track in the proximity of temporary bents or shoring towers, when located within twelve feet (12'-0") from the centerline of the track. The guardrail will be installed by CSXT forces, at the expense of the Agency or its contractor.
- E. Girders or girder systems shall be stable at all times during demolition. Temporary bracing shall be provided at the piers, abutments, or other locations to resist overturning and/or buckling of the member(s). The agency shall submit a design and details of the proposed temporary bracing system, for review by the Engineer. Lateral wind forces for the temporary conditions shall be considered in accordance with AREMA, Chapter 8, Section 28.6.2. The minimum lateral wind pressure shall be fifteen pounds per square foot (15 psf).
- F. Existing, obsolete, bridge piers shall be removed to a minimum of three feet (3'-0") below the finished grade, final ditch line invert, or as directed by the Engineer.
- G. A minimum quantity of twenty five (25) tons of CSXT approved granite track ballast may be required to be furnished and stockpiled on site by the Contractor, or as directed by the Engineer.
- H. The use of acetylene gas is prohibited for use on or over CSXT property. Torch cutting shall be performed utilizing other materials such as propane.
- I. CSXT's tracks, signals, structures, and other facilities shall be protected from damage during demolition of existing structure or replacement of deck slab.
- J. Demolition Debris Shield
1. On-track or ground-level debris shields (such as crane mats) are prohibited for use by CSXT.
  2. Demolition Debris Shield shall be installed prior to the demolition of the bridge deck or other relevant portions of the structure. The demolition debris shield shall be erected from the underside of the bridge over the track area to catch all falling debris. The debris shield shall not be the primary means of debris containment.
    - i. The demolition debris shield design and supporting calculations, all signed/sealed by a Professional Engineer, shall be submitted for review and acceptance.
    - ii. The demolition debris shield shall have a minimum design load of 50 pounds per square foot (50 psf) plus the weight of the equipment, debris, personnel, and all other loads.
    - iii. The Contractor shall verify the maximum particle size and quantity of the demolition debris generated during the procedure does not exceed the shield design loads. Shield design shall account for loads induced by particle impact; however the demolition procedure shall be such that impact forces are minimized. The debris shield shall not be the primary means of debris containment.
    - iv. The Contractor shall include installation/removal means and methods for the demolition debris shield as part of the proposed Controlled Demolition procedure submission.
    - v. The demolition debris shield shall provide twenty three feet (23'-0") minimum vertical clearance, or maintain the existing vertical clearance if the existing clearance is less than twenty three feet (23'-0").
    - vi. Horizontal clearance to the centerline of the track should not be reduced unless approved by the Engineer.
    - vii. The Contractor shall clean the demolition debris shield daily or more frequently as dictated either by the approved design parameters or as directed by the Engineer.
- K. Vertical Demolition Debris Shield
1. This type of shield may be required for substructure removals in close proximity to CSXT track and other facilities, as determined by the Engineer.
  2. The Agency or its Contractor shall submit detailed plans with detailed calculations, prepared, signed, and sealed by a Professional Engineer, of the protection shield.



## **V. ERECTION PROCEDURE**

- A. The Agency or its Contractor shall submit a detailed procedure for erection of a structure with Potential to Foul. The erection procedure must be approved by the Engineer prior to beginning work on the project.
- B. Erection work plans shall include a schematic plan depicting the following, at all stages of the construction:
1. All proposed locations of all cranes and equipment, calling out the operating radii.
  2. All proposed access and staging locations with all dimensions referenced from the center line of the nearest track.
  3. All proposed locations for stockpiling material or locations for truck loading.
  4. The location, with relevant dimensions, of all tracks, other railroad facilities; wires, poles, adjacent structures, or buried utilities that could be affected, showing that the proposed lifts are clear of these obstructions.
- C. No crane or equipment may be set on the CSXT rails or track structure and no material may be dropped on CSXT property.
- D. For erection of a structure over the tracks, the following information shall be submitted for review and acceptance by the Engineer, at least thirty (30) days prior to erection:
1. As-built beam seat elevations – field surveyed upon completion of pier/abutment construction.
  2. Current Top of Rail (TOR) elevations – field measured at the time of as-built elevation collection.
  3. Computations verifying the anticipated minimum vertical clearance in the final condition which accounts for all deflection and camber, based upon the current TOR and as-built beam seat elevations. The anticipated minimum vertical clearance shall be greater than or equal to that which is indicated by the approved plans. Vertical clearance (see definitions) is measured from TOR to the lowest point on the overhead structure at any point within six feet (6'-0") from centerline of the track. Calculations shall be signed and sealed by a Professional Engineer.
- E. Girders or girder systems shall be stable at all times during erection. No crane may unhook prior to stabilizing the beam or girder.
1. Lateral wind forces for the temporary conditions shall be considered in accordance with AREMA, Chapter 8, Section 28.6.2. The minimum lateral wind pressure shall be fifteen pounds per square foot (15 psf).
  2. Temporary bracing shall be provided at the piers, abutments, or other locations to resist overturning and/or buckling of the member(s). The agency shall submit a design and details of the proposed temporary bracing system, for review by the Engineer.
  3. Temporary bracing shall not be removed until sufficient lateral bracing or diaphragm members have been installed to establish a stable condition. Supporting calculations, furnished by the Professional Engineer, shall confirm the stable condition.
- F. Erection procedure submissions shall also include the following information:
1. All hoisting details, as dictated by Section III of this document.
  2. A time schedule for each of the various stages must be shown as well as a schedule for the entire lifting procedure. The proposed time frames for all critical subtasks (i.e., performing aerial splices, installing temporary bracing, installation of diaphragm members, etc.) shall be furnished so that the potential impact(s) to CSXT operations may be assessed and eliminated or minimized.
  3. The names and experience of the key Contractor personnel involved in the operation shall be included in the Contractor's means and methods submission.
  4. A guardrail will be required to be installed in a track in the proximity of temporary bents or shoring towers, when located within twelve feet (12'-0") from the centerline of the track. The guardrail will be installed by CSXT forces, at the expense of the Agency or its Contractor.
  5. Design and supporting calculations prepared by the Professional Engineer for items including the temporary support of components or intermediate stages shall be submitted for review.

## **VI. TEMPORARY EXCAVATION AND SHORING**

- A. The Agency or its Contractor shall submit a detailed design and procedure for the installation of a sheeting/shoring system adjacent to the tracks. Shoring protection shall be provided when excavating with Potential to Foul, or as otherwise determined by CSXT. Shoring shall be provided in accordance with the AREMA, except as noted below.
- B. Shoring may not be required if all of the following conditions are satisfied:
1. The excavation does not encroach within the Theoretical Live Load Influence Zone. Please refer to Figure 1.

2. The track structure is situated on level ground, or in a cut section, and on stable soil.
  3. The excavation does not adversely impact the stability of a CSXT facility (i.e., signal bungalow, drainage facility, undergrade bridge, building, etc), or the stability of any structure on, over, or adjacent to CSXT property with potential to foul.
  4. Shoring is not required by any governing federal, state, local or other construction code.
- C. Shoring is required when excavating the toe of an embankment. Excavation of any embankment which supports an active CSXT track structure without shoring will not be permitted.
- D. Trench boxes are not an acceptable means of shoring. Trench boxes are prohibited for use on CSXT property or within the Theoretical Railroad Live Load Influence Zone.
- E. Shoring shall be a cofferdam-type, which completely encloses the excavation. However, where justified by site or work conditions, partial cofferdams with open sides away from the track may be permissible, as determined by the Engineer.
- F. Cofferdams shall be constructed using interlocking steel sheet piles, or when approved by the Engineer, steel soldier piles with timber lagging. Wales and struts shall be included when dictated by the design.
- G. The use of tiebacks can be permissible for temporary shoring systems, when conditions warrant. Tiebacks shall have a minimum clear cover of 6'-0", measured from the bottom of the rail. Upon completion of the work, tiebacks shall be grouted, cut off, and remain in place.
- H. All shoring systems on, or adjacent to CSXT right-of-way, shall be equipped with railings or other fall protection, compliant with the governing federal, state or local requirements. Area around pits shall be graded to eliminate all potential tripping hazards.
- I. Interlocking steel sheet piles shall be used for shoring systems qualifying one or more of the following conditions:
1. Within 18'-0" of the nearest track centerline
  2. Within the live load influence zone
  3. Within slopes supporting the track structure
  4. As otherwise deemed necessary by the Engineer.
- J. Sheet piles qualifying for one or more of the requirements listed in Section VI.I (above) of this document shall not be removed. Sheet piles shall be left in place and cut off a minimum of 3'-0" below the finished grade, the ditch line invert, or as otherwise directed by the Engineer. The ground shall be backfilled and compacted immediately after sheet pile is cut off.
- K. The following design considerations shall be considered when preparing the shoring design package:
1. Shoring shall be designed to resist a vertical live load surcharge of 1,880 lbs. per square foot, in addition to active earth pressure. The surcharge shall be assumed to act on a continuous strip, eight feet six inches (8'-6") wide. Lateral pressures due to surcharge shall be computed using the strip load formula shown in *AREMA Manual for Railway Engineering*, Chapter 8, Part 20.
  2. Allowable stresses in materials shall be in accordance with AREMA Chapter 7, 8, and 15.3.
  3. A minimum horizontal clearance of ten feet (10'-0") from centerline of the track to face of nearest point of shoring shall be maintained, provided a twelve feet (12'-0") roadbed is maintained with a temporary walkway and handrail system.
  4. For temporary shoring systems with Potential to Foul, piles shall be plumb under full dead load. Maximum deflection at the top of wall, under full live load, shall be as follows:
    - i. One-half (1/2) inch for walls within twelve feet (12'-0") of track centerline (Measured from centerline of the nearest track to the nearest point of the supporting structure).
    - ii. One (1) inch for walls located greater than twelve feet (12'-0") from track centerline
- L. Shoring work plans shall be submitted in accordance with Section II of this document, as well as the following additional requirements:
1. The work plan shall include detailed drawings of the shoring systems calling out the sizes of all structural members, details of all connections. Both plan and elevation drawings shall be provided, calling out dimensions from the face of shoring relative to the nearest track centerline. The elevation drawing shall also show the height of shoring, and track elevation in relation to bottom of excavation.
  2. Full design calculations for the shoring system shall be furnished.
  3. A procedure for cutting off the sheet pile, backfilling and restoring the embankment.

## **VII. TRACK MONITORING**

- A. When work being performed has the potential to disrupt the track structure, a work plan must be submitted detailing a track monitoring program which will serve to monitor and detect both horizontal and vertical movement of the CSXT track and roadbed.
- B. The program shall specify the survey locations, the distance between the location points, and frequency of monitoring before, during, and after construction. CSXT reserves to the right to modify the survey locations and monitoring frequency as necessary during the project.
- C. The survey data shall be collected in accordance with the approved frequency and immediately furnished to the Engineer for analysis.
- D. If any movement has occurred as determined by the Engineer, CSXT will be immediately notified. CSXT, at its sole discretion, shall have the right to immediately require all contractor operations to be ceased, have the excavated area immediately backfilled and/or determine what corrective action is required. Any corrective action required by CSXT or performed by CSXT including the monitoring of corrective action of the contractor will be at project expense.

FIGURE 1: Theoretical Live Load Influence Zone

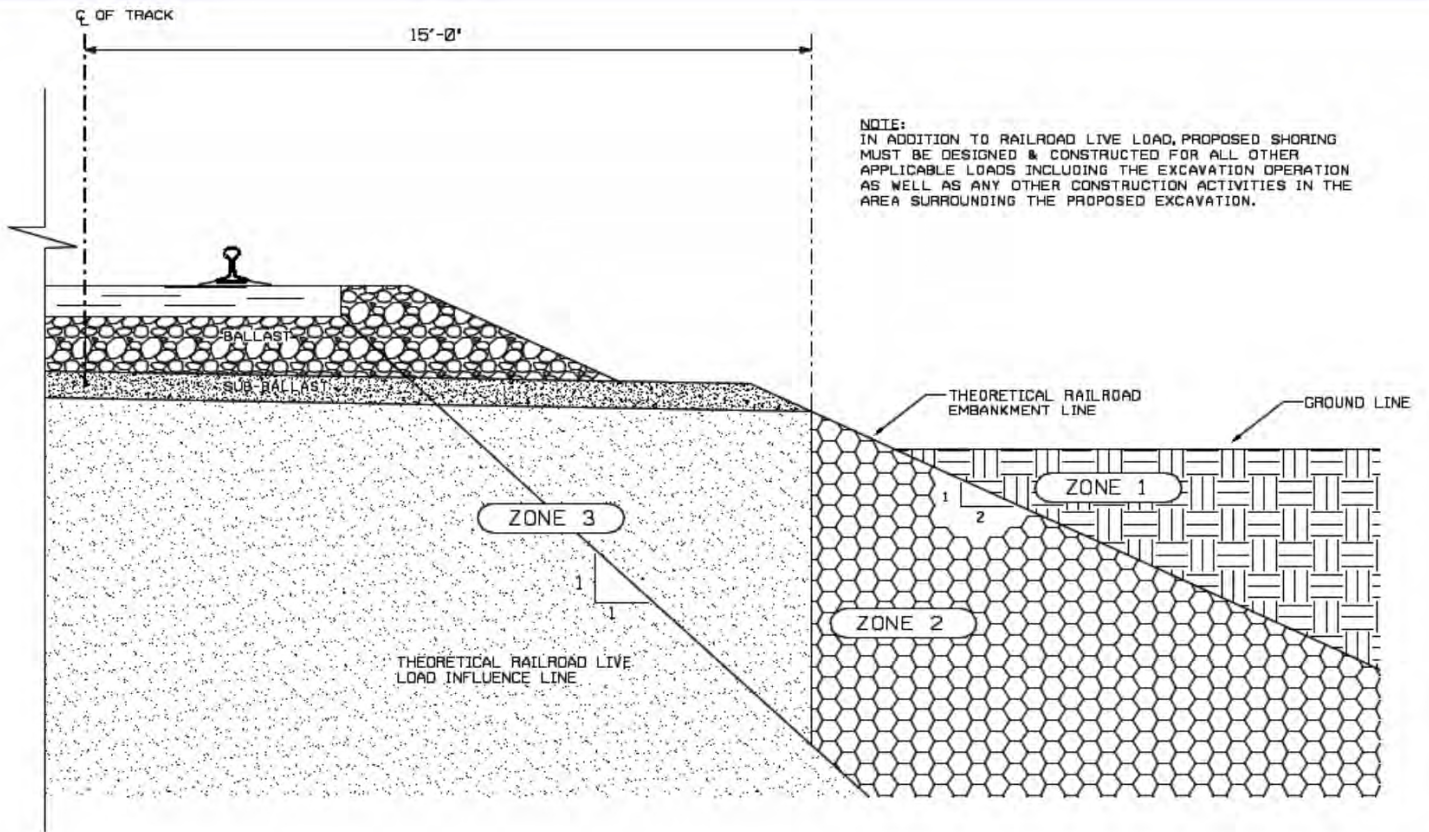

**NOTE:**  
 IN ADDITION TO RAILROAD LIVE LOAD, PROPOSED SHORING MUST BE DESIGNED & CONSTRUCTED FOR ALL OTHER APPLICABLE LOADS INCLUDING THE EXCAVATION OPERATION AS WELL AS ANY OTHER CONSTRUCTION ACTIVITIES IN THE AREA SURROUNDING THE PROPOSED EXCAVATION.

**NORMAL REQUIREMENTS FOR SHORING ADJACENT TO TRACK**

- 

ZONE 1 - EXCAVATIONS ABOVE AND OUTSIDE OF THE THEORETICAL RAILROAD EMBANKMENT LINE - DO NOT NORMALLY REQUIRE SHORING TO PROTECT RAILROAD ROADBED, SHORING MAY BE REQUIRED FOR OTHER REASONS.
- 

ZONE 2 - EXCAVATIONS WHOSE BOTTOMS EXTEND INTO ZONE 2 REQUIRE SHORING, BUT THE SHORING MAY NORMALLY BE PULLED AFTER THE EXCAVATION HAS BEEN BACKFIELD.
- 

ZONE 3 - EXCAVATIONS WHOSE BOTTOMS EXTEND INTO ZONE 3 WILL NORMALLY REQUIRE THE SHORING TO BE LEFT IN PLACE AND CUT-OFF 3' BELOW BASE OF RAIL. SHORING MUST BE DESIGNED FOR COOPER E88 LIVE LOAD

# APPENDIX

CSX Transportation

## DRAINAGE CRITERIA

CSXT Design and Construction  
Public Projects Group  
Jacksonville, FL  
Date Issued: September 9, 2014

## TABLE OF CONTENTS

- INTRODUCTION
- SECTION I: Definitions
- SECTION II: CSXT General Design Requirements
- SECTION III: Plans
- SECTION IV: Calculations & Reports
- SECTION V: Construction Specifications

## INTRODUCTION

CSXT owns its right-of-way for the primary purpose of operating a railroad. All drainage occupancies shall therefore be designed and constructed so that rail operations and facilities are not interfered with, interrupted, or endangered. In addition, the proposed facility shall be located to minimize encumbrance to the right-of-way so that the railroad will have unrestricted use of its property for current and future operations.

The CSX Design & Construction Standard Specifications for Pipelines, last revised February 24, 2010 shall serve as the overarching authority for recommended practice in providing sufficient drainage and protective measures for projects on CSXT property. The intent of this document is to provide criteria which supplements, modifies and/or supersedes the applicable sections of the AREMA Manual when designing a project which can affect drainage on or about the CSXT ROW. Additionally, these requirements help guide an outside party through the necessary procedures for interacting with CSXT and delivering an acceptable design.

### I. DEFINITIONS

1. *Agency* – The project sponsor (i.e., State DOT, Local Agencies, Private Developer, etc.)
2. *AREMA* – American Railway Engineering and Maintenance-of-Way Association – the North American railroad industry standards group. The use of this term shall be in specific reference to the *AREMA Manual for Railway Engineering*.
3. *Construction Submission* – The Agency or its representative shall submit six (6) sets of plans, supporting calculations, and detailed means and methods procedures for the specific proposed activity. All plans, specifications, and supporting calculations shall be signed/sealed by a Professional Engineer as defined below.
4. *Controlled Demolition* – Removal of an existing structure or subcomponents in a manner that positively prevents any debris or material from falling, impacting, or otherwise affecting CSXT employees, equipment or property. Provisions shall be made to ensure that there is no impairment of railroad operations or CSXT's ability to access its property at all times.
5. *Contractor* – The Agency's representative retained to perform the project work.
6. *Engineer* – CSXT Engineering Representative or a GEC authorized to act on the behalf of CSXT.
7. *Flagman* – A qualified CSXT employee with the sole responsibility to direct or restrict movement of trains, at or through a specific location, to provide protection for workers.
8. *GEC* – General Engineering Consultant who has been authorized to act on the behalf of CSXT. GECs perform preliminary engineering, construction inspection, and monitoring under the direction of the CSXT Engineering personnel. GEC personnel also perform day-to-day administration of certain types of projects.
9. *Horizontal Clearance* – Distance measured perpendicularly from centerline of any track to the nearest obstruction at any elevation between TOR and the maximum vertical clearance of the track.
10. *Professional Engineer* – An engineer who is licensed in State or Commonwealth in which the project is to occur. All plans, specifications, and supporting calculations shall be prepared by the Professional Engineer and shall bear his seal and signature.
11. *Potential to Encroach* – Work having the possibility of impacting CSXT property or operations; defined as one or more of the following:
  - a. Any activity where access onto CSXT property is required.
  - b. Any activity where work is being performed on CSXT ROW.
  - c. Any excavation work adjacent to CSXT tracks or facilities, within the Theoretical Railroad Live Load Influence Zone, or where the active earth pressure zone extends within the CSXT property limits.

- d. The use of any equipment where, if tipped and laid flat in any direction (360 degrees) about its center pin, can encroach within twenty five feet (25'-0") of the nearest track centerline. This is based upon the proposed location of the equipment during use, and may be a function of the equipment boom length. Note that hoisting equipment with the potential to foul must satisfy the 150% factor of safety requirement for lifting capacities.
- e. Any work where the scatter of debris or other materials has the potential to encroach within twenty five feet (25'-0") of the nearest track centerline.
- f. Any work where significant vibration forces may be induced upon the track structure or existing structures located under, over, or adjacent to the track structure.
- g. Any other work which poses the potential to disrupt rail operations, threaten the safety of railroad employees, or otherwise negatively impact railroad property, as determined by CSXT.

12. *ROW* – Right of Way; Refers to CSXT Right-of-Way as well as all CSXT property and facilities. This includes all aerial space within the property limits, and any underground facilities.

13. *Submission Review Period* - A minimum of 30 days will be required for the initial review response. Up to an additional 30 days may be required to review any/all subsequent submissions or resubmission.

14. *Theoretical Railroad Live Load Influence Zone* – A 1 horizontal to 1 vertical theoretical slope line starting at bottom corner of tie.

15. *TOR* – Top of Rail. This is the base point for clearance measurements. It refers to the crown (top) of the steel rail; the point where train wheels bear on the steel rails. Use the higher of the two rails when track is superelevated.

16. *Track Structure* – All load bearing elements which support the train. This includes, but is not limited to, the rail, ties, appurtenances, ballast, sub-ballast, embankment, retaining walls, and bridge structures.

17. *Vertical Clearance* – Distance measured from TOR to the lowest obstruction, within six feet (6'-0") of the track centerline, in either direction.

## II. CSXT GENERAL DESIGN REQUIREMENTS

A. Refer to CSX's Design & Construction Standard Specifications for Pipeline Occupancies, last dated February 24, 2010, for the design requirements for all pipes and drainage structures under the railroad.

B. All pipes, ditches, and other structures carrying surface drainage on CSXT property and/or under CSXT track(s) shall be designed to carry the run-off from the 100-year, 24-hour design storm without ponding of water against the roadbed.

C. Pipe(s) used to carry surface drainage on CSXT's right-of-way shall have a minimum diameter of 24 inches (24").

D. When calculating the capacity of existing or proposed drainage structures, under CSXT's track(s), the headwater calculation at the structure shall not be greater than one (1):

$$HW/D \leq 1.$$

E. Rate and quantity of storm water runoff from any proposed development shall not exceed the rate and quantity of runoff prior to development. This standard shall be maintained for all design storms up to the 100-year storm event.

F. Pipes (casing or carrier) placed under CSXT tracks shall not be less than 5.5 (5½'-0") feet from base of rail to top of pipe at its shallowest point.

G. Pipelines laid longitudinally on CSXT's right-of-way, 50 feet (50'-0") or less from centerline of track shall be buried not less than 4 feet (4'-0") from ground surface to top of pipe. Where the pipeline is laid more than 50 feet (50'-0") from centerline of track, the minimum cover shall be at least 3 feet (3'-0").

H. Erosion prevention methods shall be used to protect railroad ditches and other drainage facilities during construction on and adjacent to CSXT's right-of-way.



- I. Permanent erosion and sediment pollution control facilities shall be designed for the 100-year storm. Provide calculations and details of any riprap outlet protection and channel linings as needed within CSXT right-of-way.
- J. Pipes and culverts within the live load influence shall conform to current AREMA Recommendations and ASTM Specifications. All such structures shall be designed to carry Cooper's E-80 loading with diesel impact. Refer to CSX's Design & Construction Standard Specifications for Pipeline Occupancies approved material types and specifications.
- K. CSXT right-of-way shall not be utilized for retention, detention or settling basins. Also, the railroad embankment must not be used as any part of a detention pond structure.
- L. Track roadbed fills shall not be used as dams or levees for retention of runoff.
- M. Temporary sediment basins/traps shall not be constructed against track roadbed fill.
- N. Formal approval of the proposed design, by the appropriate governmental agency having jurisdiction, shall be submitted to CSXT for their review and acceptance.
- O. Pipes and culverts are not to be located within the limits of a turnout or nor closer than 45 feet (45'-0") to any railroad bridge, building or any other important structure.
- P. When excavation for a pipeline or other structure will be within the theoretical railroad embankment line of an adjacent track, interlocking steel sheet piling will be required to protect the track(s). Trench Boxes are prohibited for use on CSXT within the Theoretical Railroad Live Load Influence Zone. Please refer to the CSX Transportation, Construction Submission Criteria for further details regarding sheeting.
- Q. Blasting is not permitted on or adjacent to CSXT right-of-way without prior written approval from the Chief Engineer, CSXT.
- R. Crossing of tracks at grade by equipment and personnel is prohibited except by prior arrangement with and as directed by, CSXT.
- S. Temporary Track Supports may be required when jacking, boring or tunneling method of installation is used, and depending upon the size and location of the drainage crossing. The Agency's contractor shall furnish and supply the CSX approved track supports, with the installation and removal performed by CSXT employees. The Agency shall reimburse CSXT for all costs associated with the installation and removal of the track supports.
- T. Plans submitted to CSXT for approval shall be prepared by a Professional Engineer and should indicate design, suitable topographic plan, and outline of total drainage area.
- U. If the drainage is to discharge into an existing drainage channel on CSXT's right-of-way and/or through a drainage structure under CSXT's track(s), the computations must include the hydraulic analysis of any existing ditch and/or structure.
- V. Extension of pipes, culverts and other drainage structures previously installed under CSXT owned track shall be made with culvert or drainage structure having the same size, shape, and dimensions, as the existing pipe. In no case shall the existing drainage structure be extended so that the hydraulic capacity is decreased or obstructed. In some cases, it may be necessary to extend existing outlets with pipe or culvert of a larger size. Details of connections to mismatched culverts shall be submitted for CSXT approval.
- W. Agency may be required to provide reasonable corrective measures to alleviate an existing drainage problem within CSXT property which may be affected by the proposed development. It shall be the responsibility of the Agency to obtain all drainage easements and permits. CSXT shall be indemnified and held harmless of any liability.
- X. Agency is to provide information on groundwater recharge if infiltration is proposed adjacent to CSXT property. Soils testing and certification by a registered professional engineer shall be required.
- Y. Emergency spillways discharging onto CSXT property are to be designed and constructed so that the basin berm is protected against erosion.
- Z. Energy dissipating devices are to be placed at all outlets discharging to CSXT property.

AA. Concrete end walls shall be placed at outlets discharging to CSXT property. All concrete outlet pipes on CSXT property must be equipped with a trash rack.

BB. Under no conditions shall any person be allowed to modify, alter or change a previously approved storm water management (SWM) facility discharging to CSXT property unless an approved alternate facility is approved by CSXT.

CC. Design of the drainage system, including alterations of the existing drainage system on CSXT right-of-way, is the responsibility of the Agency. Drainage shall not be diverted, directed toward CSXT, or increased in quantity without prior approval and agreement with CSXT.

DD. Supporting calculations must be provided for all proposed drainage and storm water management facilities that discharge onto or impact CSXT property.

EE. Occupancies shall be designed, and their construction shall be accomplished, so that adequate and uninterrupted drainage of CSXT's rights-of way is maintained.

FF. If, in the course of construction, it may be necessary to block a ditch, pipe, or other drainage facility, temporary pipes, ditches, or other proposed drainage facilities shall be installed to maintain adequate drainage, as approved by CSXT. Upon completion of the Project, the temporary facilities shall be removed and the permanent facilities restored.

GG. Temporary and permanent erosion control and sedimentation (E&S) devices must be provided to prevent the flow of sediment onto and adjacent to CSXT property.

HH. The design shall take into account and provide upstream areas within the entire watershed in computing discharge, sizing of pipes, inlets, and other structures.

II. When applicable, Agency is to provide maintenance and operation of E&S/Storm water facilities.

### **III. PLANS**

A. Plans shall include the following, but not limited to:

1. Existing property boundaries, easements, etc.
2. Existing drainage features and topography
3. Existing utility locations
4. Existing structures, tracks, roads, features, etc.
5. Existing topography including wetlands and all environmental features
6. Delineate & Dimension proposed property acquisition or property easements
7. Dimension distances from all temporary and proposed E&S and storm water management facilities to CSXT's property line and/or easement
8. Dimension distances from all temporary and proposed E&S and storm water management facilities to CSXT's tracks
9. Dimension all temporary and proposed encroachments within CSXT's property
10. Show existing contours
11. Provide TOR elevations
12. Provide proposed contours, site grading and drainage facilities
13. Provide proposed improvements, including easements and property lines and limit of disturbance

14. Details for all temporary and proposed drainage structures, SWM and E&S Best Management Practices (BMP) devices
15. Detail proposed E&S, SWM, drainage collection & conveyance systems (pipes, ditches, etc.)
  - i. Provide location, size, slope & type of pipe.
  - ii. Ditch cross sections
  - iii. Invert elevations
  - iv. Grate and rim elevations
16. If applicable, identify the 100-year floodplain if project is within a specified flood zone.
17. Provide E&S Plans in compliance with all State and Local requirements.
18. Signature and Seal of State Licensed PE

#### **IV. CALCULATIONS & REPORTS**

##### A. Design Calculations:

1. Pre and post development Drainage Area Maps
  - i. Provide soils boundary lines & soil types
  - ii. Delineate drainage areas
  - iii. Time of Concentration (Tc) flow path
  - iv. Provide weighted CN and c-values (as applicable to design method)
2. Pre-development 100-year runoff volume and flows for all facilities draining to or on CSXT ROW
3. Post-development 100-year runoff volume and flows for all facilities draining to or on to CSXT ROW
  - i. Verify no increase in rate or quantity of runoff to CSXT property from Pre-Development conditions
  - ii. Provide hydraulic analysis (depth and velocity calculations) for all facilities draining to or on CSXT ROW (existing and proposed) and verify sufficient capacity for proposed flow is provided.
4. Design of proposed collection & conveyance systems (pipes, ditches, etc.)
  - i. CSXT requires capacity for a 100-year, 24 hour storm
  - ii. CSXT requires a minimum diameter of 24-inches for pipes within CSXT ROW
5. Provide all temporary and permanent E&S and SWM BMP calculations
6. Signature and Seal of State Licensed PE

B. Project narrative/summary describing proposed improvements, drainage design, SWM and E&S methodologies, site soil and geological conditions (if known), flooding characteristics (if applicable) and State and Local requirements used to produce designs.

C. Recommended: Photographs of the site and adjacent CSXT property, as well as discharge locations and drainage facilities on CSXT property to receive runoff from the proposed development.

## **V. CONSTRUCTION SPECIFICATIONS**

A. Construction shall be in accordance to the CSX Design & Construction Standard Specifications for Pipeline Occupancies, last revised February 24, 2010 or latest revision, under the Construction Requirements section.

B. All work on or near CSXT property shall be conducted in accordance with CSXT safety rules and regulations. Specifically all Agency's employees and Contractors, while on CSXT property, shall be required to wear a hard hat, safety glasses with side shields, 6" lace up boots with a distinct heel, shirts with sleeves, and long pants; additional personal protective equipment may be required based on certain operations. The Contractor and its employees shall comply with the CSXT safety rules at all times while occupying CSXT's property. Operations will be subject to CSXT inspection at any and all times. All personnel operating equipment must be qualified on it to perform task at hand.

C. For the installation of temporary or permanent shoring systems, including but not limited to soldier piles and lagging, and interlocked steel sheeting on or adjacent to CSXT's right-of-way, the contractor may be required to submit a detailed track monitoring program for CSXT's approval prior to performing any work near CSXT's right-of-way. Please refer to CSX Transportation, Construction Submission Criteria for additional information.

D. When water is known or expected to be encountered all plans and specifications must be submitted to the Engineer for approval before the process begins. Pumps of sufficient capacity to handle the flow shall be maintained at the site, provided the contractor has received approval from CSXT to operate them. Pumps in operation shall be constantly attended on a 24-hour basis until, in the sole judgment of CSXT, the operation can be safely halted. When dewatering, a process for monitoring for any settlement of track or structures must be in place.

E. If any track movement has occurred as determined by the Engineer, CSXT will be immediately notified. CSXT, at its sole discretion, shall have the right to immediately require all contractor operations to be ceased, have the excavated area immediately backfilled and/or determine what corrective action is required. Any corrective action required by CSXT or performed by CSXT including the monitoring of corrective action of the contractor will be at project expense.

F. Installation by the open cut method is not approved under CSXT's mainline tracks, tracks carrying heavy tonnage or tracks carrying passenger trains. Also, open cut shall not be used within the limits of a highway/railroad grade crossing or its approaches, 25 feet (25'-0") either side of traveled way, where possible.

# APPENDIX

## CSX Transportation

### SOIL AND WATER MANAGEMENT POLICY

CSXT Design and Construction  
Public Projects Group  
Jacksonville, FL  
Date Issued: July 2017

# Soil and Water Management Policy

Public projects that generate soils from CSXT property must adhere to CSXT's soil management policies. CSXT requires soils generated from its property to either be properly disposed in a CSXT approved disposal facility or reused on CSXT property. The management of soils generated from CSXT property should be planned for and properly permitted (if applicable) prior to initiating any work on CSXT property.

## Overview

- Soil Reuse: CSXT Environmental Department must review and approve reuse of soil on CSXT property.
- Soil Disposal: If the soil cannot be reused on CSXT property, it must be properly disposed at a CSXT approved disposal facility. CSXT prohibits any contractor from taking soils for off property reuse. CSXT Environmental Department will handle waste characterization and profiling into an approved disposal facility. CSXT prohibits any environmental sampling on its property unless granted through a written Environmental Right of Entry or approved in writing by the CSXT Environmental Department. If Agency has arrangements with a disposal facility not approved by CSXT, Agency can request CSXT to evaluate the disposal facility. Request to evaluate alternate disposal facilities should take place prior to work being initiated on CSXT property.
- If dewatering is planned for a public project, CSXT Environmental Department must review and approve the dewatering plan prior to work being initiated on CSXT property. CSXT prohibits the discharge of water onto its property without prior approval. CSXT prohibits environmental sampling of groundwater or surface water unless granted through a written Environmental Right of Entry or approved in writing by the CSXT Environmental Department.
- It is the policy of CSXT that all materials discarded by or on behalf of CSXT will be managed in accordance with local, state and federal regulations as well as CSXT's best management practices and sustainability goals. To ensure that these goals are achieved, CSXT has mechanisms in place to monitor waste management activities, capture the information necessary to ensure 100% compliance with local, state and federal requirements 100% of the time, and track progress in the CSXT sustainability program. These mechanisms also allow CSXT to complete reporting requirements to federal and state regulatory agencies and document CSXT's progress toward its sustainability goals.
- Containment system, clean up and disposal of all paint and other material removed from a bridge: The clean-up and disposal of material from the surface preparation for painting and actual painting must comply with all appropriate regulations. The materials removed during the surface preparation must not impact the surrounding area including ground, water, or air impacts. Materials must not be stored on CSXT property.

# APPENDIX

## CSX Transportation

### Trail Construction Under CSXT Bridges

CSXT Design and Construction  
Public Projects Group  
Jacksonville, FL  
Date Issued: July 2017

# Trail Construction Under CSXT Bridges

## Overview

### A. Plan Requirements

1. Plans shall show all clearances between the proposed trail and the bridge structure.
2. A canopy will be installed under the CSXT bridge, the minimum clearance between the top of the canopy and the underside of the bridge shall be 5 feet (5'-0"). The trail in the vicinity of the undergrade bridge must be able to be closed and the canopy removed as necessary to allow CSXT access to inspect and maintain the bridge. The trail must remain closed until the CSXT work is completed and the canopy and fencing is restored. CSXT will not be responsible for any damage to the portions of the canopy and fencing that occur due to CSXT inspection, maintenance, operations or other work.
3. Provide the closure procedure for periods when the trail will require closure in the vicinity of the undergrade bridge due to CSXT inspection, maintenance or other operations.
4. Provide fencing along the trail in the vicinity of the undergrade bridge to prevent trespassing near the active CSXT track area and facilities. Gates must be provided to readily permit CSXT access to the undergrade bridge areas from below the bridge. CSXT to provide lock.
5. The canopy shall be adequately designed to sustain the impact of debris falling from the CSXT bridge. Debris with potential to fall includes but is not limited to tie plates which are approximately 18" x 8" x 1-1/2" and weigh approximately 36.5 pounds.
6. Please clearly show and label the CSXT right of way lines on the plans.
7. A canopy shall extend at least 15 feet (15'-0") beyond the bridge fascias on either side of the bridge.
8. Provide details for signage to prevent trespassers from accessing the CSXT right of way.

### B. Construction Submittals

1. During construction, CSXT will review all submittals relating to the installation of the trail components in relation to the bridge structure.

## **Pedestrian Underpass Canopy Review Guidelines:**

1. Designed to stop a 30 pound object dropped from the train (ex. a knuckle break from a coupler). Generally, a double layered 3/4" plywood roof deck with corrugated metal covering or asphalt shingles.

The roof deck shall have a minimum 2% slope for drainage purposes, as well as to deflect falling objects off of the canopy structure and away from the pedestrian walkway.

2. Length of overhead protection required is generally determined by a 1:1 slope projected in each direction from a point 8 feet (8'-0") above the outside rail of the overhead railroad track, down to the intersection of the 1:1 slope and the finished grade or a minimum of 25 feet (25'-0") outside the limits of the railroad structure, both sides, whichever is greater. See Attachment A.
3. Pedestrian canopy must be 12 feet (12'-0") below the bottom of the railroad bridge superstructure (girders, bracing, etc.) and 5 feet (5'-0") clear of the substructure (piers, piling, etc.) to allow visual inspection and maintenance of all components of the railroad bridge.
4. Should CSX require additional access to the area under the tracks for maintenance and/or future bridge replacement, the owner is responsible for removal and reconstruction of the pedestrian canopy.



CSX TRANSPORTATION, INC.  
500 Water Street  
Jacksonville, FL 32202  
[www.csx.com](http://www.csx.com)

HOW TOMORROW MOVES





# **DESIGN AND CONSTRUCTION STANDARD SPECIFICATIONS**

## **Pipeline Occupancies**

OFFICE OF:  
VICE PRESIDENT - ENGINEERING  
JACKSONVILLE, FLORIDA  
ISSUED: September 15, 2003  
REVISED: June 5, 2018

**THIS PAGE BLANK**



---

<b>Part 1 – Introduction</b>	<b>PAGE</b>
1.1 Scope .....	1
1.2 Definitions .....	1
1.3 Application for Occupancy .....	1
1.4 Right of Entry .....	2
1.5 Site Inspection .....	2
1.6 Information Required for Submission .....	2
1.7 Notification to Proceed with Outside Party Request Form .....	3
<b>Part 2 – General Requirements</b>	
2.1 Use of Casing Pipe .....	5
2.2 Location of Pipeline on the Right-of-Way .....	5
2.3 Depth of Installation .....	6
2.3.1 Pipelines conveying non-flammable substances .....	6
2.3.2 Pipelines conveying flammable substances .....	6
2.3.3 Pipelines within Limits of a Dedicated Highway .....	6
2.4 Modification of Existing Facilities .....	7
2.5 Abandoned Facilities .....	7
2.6 Conflict of Specifications .....	8
2.7 Insulation .....	8
2.8 Corrosion Protection and Petroleum Leak Prevention .....	8
2.9 Plastic Carrier Pipe Materials .....	8
<b>Part 3 – Design Requirements</b>	
3.1 Soil Investigation .....	11
3.1.1 General Requirements .....	11
3.1.2 Location .....	11
3.1.3 Sampling .....	11
3.1.4 Boring Logs .....	11
3.1.5 Additional Information .....	12
3.2 Design Loads .....	12
3.2.1 General Requirements .....	12
3.2.2 Earth Load .....	12
3.2.3 Railroad Load (live load and impact) .....	12
3.3 Design Assumptions .....	13
3.3.1 Flexible Pipe (Steel, DIP, CMP, and Tunnel Liner Plate) .....	14
3.3.2 Rigid Pipe (RCP, Vitrified Clay Pipe, and PCCP) .....	14
3.4 Casing Pipe .....	15
3.4.1 General Requirements .....	15
3.4.2 Steel Pipe .....	16
3.4.3 Ductile Iron Pipe .....	17
3.4.4 Corrugated Steel and Corrugated Structural Steel Plate Pipe .....	18
3.4.5 Steel Tunnel Linear Plate .....	19
3.4.6 Reinforced Concrete Pipe .....	19
3.4.7 Concrete Encasement .....	20
3.5 Carrier Pipe .....	20
3.5.1 General Requirements .....	20
3.5.2 Pipelines Carrying Flammable Substances .....	21
3.5.3 Uncased Pipelines Carrying Gas .....	21

---



---

<b>Part 3 – Design Requirements (Continued)</b>	<b>PAGE</b>
3.6 Casing Pipe End Seals .....	22
3.7 Vents .....	22
3.8 Signs .....	22
3.9 Warning Tape .....	23
3.10 Shut-off Valves .....	23
3.11 Cathodic Protection .....	23
3.12 Manholes .....	24
3.13 Box Culverts .....	24
3.14 Drainage .....	24
3.15 Pipelines on Bridges .....	25
3.16 Cured-in-Place Pipes (CIPP) .....	25
3.17 Pipe Bridges/ Conveyors .....	25

**Part 4 – Construction Requirements**

4.1 Method of Installation .....	28
4.1.1 General Requirements .....	28
4.1.2 Bore and Jack (Steel Pipe) .....	28
4.1.3 Jacking (RCP and Steel Pipe) .....	29
4.1.4 Tunneling (Tunnel Liner Plate) .....	29
4.1.5 Horizontal Directional Drilling .....	30
4.1.6 Jack Conduit .....	30
4.1.7 Open Cut – Not a readily accepted practice .....	30
4.2 Grouting .....	31
4.3 Soil Stabilization .....	31
4.4 Dewatering .....	32
4.5 Safety Requirements .....	32
4.6 Blasting .....	32
4.7 Temporary Track Supports .....	32
4.8 Protection of Drainage Facilities .....	33
4.9 Support of Excavation Adjacent to Track .....	33
4.9.1 Launching and Receiving Pits .....	33
4.9.2 Parallel Trenching and Other Excavation .....	33
4.9.3 Inspections and Testing .....	34
4.9.4 Reimbursement of CSXT Costs .....	34

**Part 5 – Publication Standards Sources**

5.1 Publication Standards Sources .....	36
-----------------------------------------	----

**Tables**

Table 1 Live loads, including impact for various heights of cover for a Cooper E-80 loading .....	13
Table 2 Steel Casing Pipe Wall Thicknesses .....	17
Table 3 Ductile Iron Pipe Wall Thicknesses .....	18
Table 4 Corrugated Steel Pipe Wall Thicknesses .....	19
Table 5 Publication Standards Sources .....	36

END OF TABLE OF CONTENTS



## **PART 1 – INTRODUCTION**

### **1.1 Scope**

- a) This specification shall apply to the design and construction of pipelines carrying flammable or non-flammable substances and casings containing wires, cables, and carrier pipes across and along CSXT property and facilities. This specification shall also apply to tracks owned by others (sidings, industry tracks, etc.) over which CSXT operates its equipment.
- b) It is to be clearly understood that CSXT owns its right-of-way for the primary purpose of operating a railroad. All occupancies shall therefore be designed and constructed so that rail operations and facilities are not interfered with, interrupted, or endangered. In addition, the proposed facility shall be located to minimize encumbrance to the right-of-way so that the railroad will have unrestricted use of its property for current and future operations.

### **1.2 Definitions**

CSXT	CSX Transportation, Inc.
CS	Corridor Services
Owner (Applicant)	Individual, Corporation, or Municipality desiring occupancy of CSXT property
Professional Engineer	Engineer licensed in the state where the facilities are to be constructed
Carrier Pipe	Pipe used to transport the commodity
Casing Pipe	Pipe through which the carrier pipe is installed under main tracks
Sidings or Industry Tracks	Tracks located off of CSXT's right-of-way, serving an industry

### **1.3 Application for Occupancy**

- a) Owner (Applicant) desiring occupancy of CSXT property by pipeline occupations must satisfy the following: receive approval by CSXT of all engineering and construction details, execute an appropriate CSXT occupational agreement, and remit payment of any required fees and/or rentals specified therein.
- b) Occupancy applications shall be completed in full with all of the required information requested in order for the application to be processed. Review the entire application package, as well as the engineering specifications, before completing the application.

Applications must be submitted through the CSX Property Portal. Visit [www.csx.com](http://www.csx.com) to establish an account and submit an application. Once on the site, use the following path: CUSTOMERS→CSX Real Estate→CSX Property Portal.

#### **1.4 Right of Entry**

- a) Entry upon CSXT property for the purpose of conducting surveys, field inspections, obtaining soils information, or any other purposes associated with the design and construction for the proposed occupancy, will not be permitted without a proper entry permit prepared by CSXT. The applicant must pay the associated fees and execute the entry permit.
- b) The issuance of an entry permit does not constitute authority to proceed with any construction. Construction cannot begin until a formal agreement is executed by CSXT and the Owner receives permission, from the designated inspection agency of CSXT, to proceed with the work.

#### **1.5 Site Inspection**

- a) For longitudinal occupancy of CSXT property, a site inspection along the proposed pipeline route may be required before final design plans are prepared. When a site inspection is required, the applicant and/or the engineer must meet with a CSXT Field Representative to view the entire length of the proposed occupancy; the applicant will be informed of the need for a meeting during application processing.
- b) Prior to the site inspection the applicant must submit the following information:
  - i) A plan view of the proposed route showing all tracks, both CSXT right-of-way lines, and all other facilities located on the right-of-way. The distance from the proposed pipeline to the adjacent track and to the right-of-way lines must be shown.
  - ii) A complete application form.
- c) Site inspections for pipe crossings are not required unless, in the opinion of CSXT, the size and location of the facility warrant an inspection.

#### **1.6 Information Required for Submission**

- a) All plans and documents required in the application package shall be submitted as per the instructions in the application package.
- b) Failure to follow these instructions may result in the return of the information provided without further action taken.

### **1.7 Notification to Proceed with Outside Party Request Form**

- a) After approval of the engineering plans and full execution of the facility encroachment agreement, the Owner will receive an e-mail notification containing a special reference number and link to the CSX Property Portal – Outside Party Request Form application. CSX requires 30 days' advance notice to schedule any activity.
- b) Once the OP Form is received, the Owner or their Contractor will be contacted to discuss construction scheduling.
- c) CSXT will determine if the project requires flagging, construction monitoring, or both. All costs associated with flagging and/or construction monitoring will be the responsibility of the Owner. CSXT, at its sole discretion, may elect to have the Owner remit payment for the estimated flagging/construction monitoring cost in advance or elect to invoice the Owner the actual cost as incurred.

**END OF PART 1**



**THIS PAGE BLANK**

---

## **PART 2 – GENERAL REQUIREMENTS**

### **2.1 Use of Casing Pipe**

- a) A casing pipe will be required for all pipeline crossings carrying liquid or gaseous substances. The casing pipe for liquid and gaseous substances may be omitted if the proposed pipe will be installed by the horizontal directional drilling (HDD) method. Reference section 4.1.5 for additional information and requirements.
- b) For natural gas pipelines, the casing pipe may be omitted provided the carrier pipe meets the requirements in the Uncased Pipelines Carrying Gas section of this document. CSXT may require the use of a casing pipe at locations where increased risks from specific site conditions (traffic speed, traffic density, etc.) are present.
- c) For non-pressure sewer or drainage crossings, where the installation can be made by open cut (see Construction Requirements Section) or reinforced concrete pipe can be jacked under the railroad (see Construction Requirements Section), the casing pipe may be omitted.
- d) Pressure pipelines that are located within 25 feet of the centerline of any track shall be encased.
- e) At proposed pipe crossing the casing pipe shall be laid **across the entire width of the right-of-way**, except where a greater length is required to comply with the Design Requirements-Casing Pipe Section of this specification, even though such extension is beyond the right-of-way.
- f) At the discretion of CSXT a casing pipe may be required for any application regardless of the commodity carried.

### **2.2 Location of Pipeline on the Right-of-Way**

- a) Pipelines laid longitudinally on CSXT's right-of-way shall be located as far as practicable from any tracks or other important structures and as close to the railroad property line as possible. Longitudinal pipelines must not be located in earth embankments or within ditches located on the right-of-way.
- b) Pipelines shall be located, where practicable, to cross tracks at approximate right angles to the track, but preferably at not less than 45 degrees.
- c) Pipelines shall not be placed within a culvert, under railroad bridges, nor closer than 45 feet to any portion of any railroad bridge, building, or other important structure, except in special cases, and then by special design, as approved by CSXT's Chief Engineer, Design and Construction. Proposed pipelines that are to be located within the public right-of-way will be considered pending engineering review. An effort should be made to maximize distance to any substructure.
- d) Pipelines shall not be located within the limits of a turnout (switch) when crossing the track. The limits of the turnout extend from the point of the switch to 15 feet beyond the last long timber.

- e) Pipeline installations shall not be designed as an open cut installation where the pipeline is to be located within the limits of a grade crossing. If it is shown that no other method of installation is possible, the owner will be responsible for reimbursing CSXT for all costs associated with the removal and reconstruction of the grade crossing (This cost will require advance funding by the pipeline owner).
- f) Pipelines carrying liquefied petroleum gas shall, where practicable, cross the railroad where tracks are carried on embankment.

## **2.3 Depth of Installation**

### **2.3.1 Pipelines conveying non-flammable substances**

- a) Casing/carrier pipes placed under CSXT track(s) shall be not less than 5.5 feet from base of rail to top of pipe at its shallowest point.
- b) Pipelines laid longitudinally on CSXT's right-of-way, 50 feet or less from centerline track shall be buried not less than 4 feet from ground surface to top of pipe. Where the pipeline is laid more than 50 feet from centerline of track, the minimum cover shall be at least 3 feet.

### **2.3.2 Pipelines conveying flammable substances**

- a) Casing pipes under CSXT track(s) shall be not less than 5.5 feet from base of rail to top of pipe at its closest point. On other portions of the right-of-way, where the pipe is not directly beneath any track, the depth from ground surface or from bottom of ditch to top of pipe shall not be less than 3 feet. Where 3 feet of cover cannot be provided from bottom of ditch, a 6-inch thick reinforced concrete slab shall be provided over the pipeline for protection.
- b) Uncased natural gas pipelines under CSXT track(s) shall not be less than 10 feet from the base of rail to the top of the pipe at its closest point and not less than 6 feet from ground surface to top of pipe in all other locations. Where it is not possible to obtain the above depths, use of a casing pipe will be required.
- c) Pipelines laid longitudinally on CSXT's right-of-way, 50 feet or less from centerline track shall be buried not less than 6 feet from ground surface to top of pipe. Where the pipeline is laid more than 50 feet from centerline of track, the minimum cover shall be at least 5 feet.

### **2.3.3 Pipelines within Limits of a Dedicated Highway**

- a) Pipelines within the limits of a dedicated highway are subject to all the requirements of this specification and must be designed and installed in accordance with this specification.
- b) The limits of the dedicated highway (right-of-way) must be clearly shown on the plans.

- c) Construction cannot begin until an agreement has been executed between CSXT and the Owner and proper notification has been given to CSXT's Regional Engineering Officer (See Notification to Proceed with Outside Party Request Form).

#### **2.4 Modification of Existing Facilities**

- a) Any replacement of an existing carrier pipe and/or casing shall be considered as a new installation, subject to the requirements of this specification.
- b) Modification of an existing carrier pipe and/or casing pipe by in-place, non-intrusive methods, such as Cured-in-Place Pipe (CIPP), may be considered as maintenance if there is an agreement between CSXT and the owner covering the existing pipe(s).
- c) CIPP installations will only be considered for the following scenarios:
  - i) Circular Pipes
  - ii) Within the following host pipe materials: brick, concrete, clay tile, vitrified clay, PVC, corrugated steel, cast and ductile iron, fiberglass, or AC pipe. CIPP will not be allowed within smooth wall steel pipes.
- d) CIPP design and installation plans and calculations must be submitted to CSXT's Corridor Services (CS) office for an engineering review if the following scenarios exist:
  - i) Excavation within CSXT right-of-way or TREL is required to access the existing facilities.
  - ii) The host pipe that the CIPP is being applied to is not within a casing pipe, such that the host pipe and CIPP will be subject to all external loads.
  - iii) The CIPP will be within a pipe that is parallel or longitudinal to the CSXT tracks.
- e) CIPP design requirements are included in the Cured-in-Place-Pipes (CIPP) section of this document.

#### **2.5 Abandoned Facilities**

- a) The owner of all pipe crossings proposed for abandonment shall notify CSXT, in writing, of the intention to abandon.
- b) Abandoned pipelines shall be removed or completely filled with cement grout, compacted sand, or other methods, as approved by CSXT.
- c) Abandoned manholes and other structures shall be removed to a minimum depth of 2 feet below finished grade and completely filled with cement grout, compacted sand, or other methods as approved by CSXT.

## 2.6 Conflict of Specifications

- a) Where laws or orders of public authority prescribe a higher degree of protection than specified herein, then the higher degree so prescribed shall be deemed a part of this specification.

## 2.7 Insulation

- a) Pipelines and casings shall be suitably insulated from underground conduits carrying electric wires on CSXT property.

## 2.8 Corrosion Protection and Petroleum Leak Prevention

- a) Pipelines on CSXT property that carry petroleum products, hazardous gases, or hazardous liquids shall be designed in accordance with current federal, state, and/or local regulations that mandate leak detection automatic shutoff, leak monitoring, sacrificial anodes, and/or exterior coatings to minimize corrosion and prevent petroleum releases.

## 2.9 Plastic Carrier Pipe Materials

- a) Plastic carrier pipe materials include, but are not limited to thermoplastic and thermoset plastic pipes, Thermoplastic types include Polyvinyl Chloride (PVC), Acrylonitrile Butadiene Styrene (ABS), High Density Polyethylene (HDPE), Polyethylene (PE), Polybutylene (PB), Cellulose Acetate Butyrate (CAB), and Styrene Rubber (SR), Thermoset types include Reinforced Plastic Mortar (RPM), Reinforced Thermosetting Resin (FRP) and Fiberglass Reinforce Plastic (FRP).
- b) Plastic carrier pipelines shall be encased according to AREMA Chapter 1 Section 5.1.5.
- c) Plastic pipe material shall not be used to convey **liquid** flammable substances.
- d) Plastic pipe material shall be resistant to the chemicals with which contact can be anticipated. Plastic carrier pipe shall not be utilized where there is potential for contact with petroleum contaminated soils or other non-polar organic compounds that may be present in surrounding soils.
- e) Plastic carrier pipe can be utilized to convey flammable **gas** products provided the pipe material is compatible with the type of product conveyed and the maximum allowable operating pressure is less than 100 PSI. Carrier pipe materials, design, and installation shall conform to Code of Federal Regulation 49CFR§178 to §199, specifically §192 and American National Standards Institute ASME B31.8 and ASTM D2513. Codes, specifications, and regulations current at time of construction of the pipeline shall govern the installation of the facility within the railway right-of-way. The proof testing of the strength of carrier pipe shall be in accordance with ANSI requirements. Plastic carrier pipes will be encased according to AREMA Chapter 1 Section 5.1.5.
- f) Plastic carrier pipe conveying flammable substances shall be encased the entire limits of the right-of-way. If special conditions exist which prevent encasement within the entire limits

of the right-of-way, the Chief Engineer, Design and Construction must approve the minimum encased length.

- g) Plastic carrier pipe must be encased under all tracks, including sidings and industrial tracks within the limits of the right-of-way.
- h) Longitudinal carrier pipeline shall be steel or ductile iron. Plastic carrier pipe may be utilized for longitudinal installation with approval by the Chief Engineer, Design and Construction, but shall be fully encased within the limits of the right-of-way.
- i) Codes, specifications, and regulations current at the time of construction the pipeline shall govern the installation of the facility within the railway rights-of-way. The proof testing of the strength of carrier pipe shall be in accordance with ANSI requirements.

Specification Number

ANSI/AWWA C900

ANSI/AWWA C901

ANSI/AWWA C902

ANSI/AWWA C905

ANSI/AWWA C906

ANSI/AWWA C907

ANSI/AWWA C950

Carrier Pipe Properties

PVC pressure pipe 4” through 12”

PE pressure pipe and tubing ½” through 3” for water

PE pressure pipe and tubing ½” through 3” for water

PVC water pipe, 14” through 36”

PE pressure pipe and fittings 4” – 63” for water

PVC pressure fittings 4” – 8”

Fiberglass pressure pipe

**END OF PART 2**

**THIS PAGE BLANK**

---

## **PART 3 – DESIGN REQUIREMENTS**

### **3.1 Soil Investigation**

#### **3.1.1 General Requirements**

- a) Test borings or other soil investigations, approved by CSXT's Chief Engineer, Design and Construction, shall be made to determine the nature of the underlying material for all pipe crossings with casing pipe sizes greater or equal to 48 inches in diameter and larger under track(s).
- b) Test borings or other soil investigations, approved by CSXT's Chief Engineer, Design and Construction, may be required when, in the judgment of CSXT, they are necessary to determine the adequacy of the design and construction of pipe crossings with casings less than 48 inches in diameter and for other facilities located on the right-of-way. Note: the applicant shall be responsible for the notification of all underground utilities including CSX signal cables.

#### **3.1.2 Location**

- a) Borings shall be made on each side of the track(s), on the centerline of the pipe crossing, and as close to the track(s) as practicable. **Entry upon CSXT property for the purpose of conducting borings requires a Right of Entry permit.**
- b) Test boring logs shall be accompanied with a plan, drawn to scale, showing the location of the borings in relation to the track(s) and the proposed pipe.

#### **3.1.3 Sampling**

- a) Test borings shall be made in accordance with current ASTM Designation D1586 except that sampling must be continuous from the ground surface to 5 feet below the proposed invert unless rock is encountered before this depth. Where rock is encountered, it is to be cored using a Series "M" Double Tube Core Barrel, with a diamond bit, capable of retrieving a rock core at least 1 5/8" in diameter. Individual core runs are not to exceed 5 feet in length.
- b) All borings shall be sealed, for their full depth, with a 4-3-1 bentonite-cement- sand grout after accurate ground water readings have been taken and recorded.
- c) Soil samples taken from auger vanes or return washwater are not acceptable.

#### **3.1.4 Boring Logs**

- a) Test boring logs shall clearly indicate **all** of the following:
  - i) Boring number as shown on the required boring location plan.
  - ii) Ground elevation at each boring using same datum as the pipeline construction plans.



- iii) Engineering description of soils or rock encountered.
  - iv) Depth and percent recovery of all soil samples.
  - v) Depth from surface for each change in strata.
  - vi) Blows for each 6 inches of penetration for the standard penetration test described in ASTM D 1586. Blows for lesser penetrations should be recorded.
  - vii) Percent recovery and Rock Quality Designation (RQD) for all rock cores.
  - viii) Depth to ground water while sampling and when it has stabilized in the bore hole.
- b) The location of the carrier pipe and/or casing pipe shall be superimposed on the boring logs before submission to CSXT.

### **3.1.5 Additional Information**

- a) When directed by CSXT, additional borings may be required for the purpose of taking undisturbed thin-wall piston samples or Dennison type samples for laboratory testing to determine the index and engineering properties of certain soil strata.

## **3.2 Design Loads**

### **3.2.1 General Requirements**

- a) All pipes, manholes, and other facilities shall be designed for the external and internal loads to which they will be subjected.
- b) To allow for placement of additional track(s) or shifting of the existing track(s), all proposed pipelines or structures shall be designed as if a railroad loading is directly above the facility.

### **3.2.2 Earth Load**

- a) The dead load of the earth shall be considered as 120 pounds per cubic foot unless soil conditions warrant the use of a higher value.

### **3.2.3 Railroad Load (live load and impact)**

- a) The railroad live load used shall be a Cooper E-80 loading. This loading consists of 80 kip axle loads spaced 5 feet on centers.
- b) An impact factor of 1.75 (multiply live load by the impact factor) shall be used for depth of cover up to 5 feet. Between 5 and 30 feet, the impact factor is reduced by 0.03 per foot of depth. Below a depth of 30 feet, the impact factor is one.
- c) The values shown in Table 1 shall be used for the vertical pressure on a buried structure for the various heights of cover.

Table 1 - Live loads, including impact for various heights of cover for a Cooper E-80 loading

Height of Cover	Load	
	Pound per square foot	(kPa)
2	3800	(162.8)
3	3150	(150.8)
4	2850	(136.5)
5	2550	(122.1)
6	2250	(107.7)
7	1950	(93.4)
8	1700	(81.4)
9	1500	(71.8)
10	1300	(62.2)
12	1000	(47.9)
14	800	(38.3)
16	625	(29.9)
18	500	(23.9)
20	400	(19.2)
25	250	(12.0)
30	150	(7.2)

- d) To determine the horizontal pressure caused by the railroad loading on a sheet pile wall or other structure adjacent to the track, the Boussinesq analysis shall be used. The load on the track shall be taken as a strip load with a width equal to the length of the ties which is typically, 8.5 feet. The vertical surcharge,  $q$  (psf), caused by each axle, shall be uniform and equal to the axle load divided by the tie length and the axle spacing, 5 feet. For the E-80 loading this results in:

$$q = 80,000 / (8.5 \times 5) = 1882 \text{ psf}$$

The horizontal pressure due to the live load surcharge at any point on the wall or other structure is  $p_h$  and can be calculated by the following:

$$p_h = (2q/\pi)(\beta - \sin \beta (\cos 2\alpha))$$

- e) The vertical and horizontal pressures given above shall be used unless an alternate design method is approved by CSXT. Proposals to use an alternate design method must include acceptable references and a statement explaining the justification for choosing the alternate method.

### 3.3 Design Assumptions

- a) To design a casing pipe or an uncased carrier pipe for the external loads on CSXT's right-of-way, the following design assumptions shall be used, unless site conditions indicate more conservative values are required:

### 3.3.1 Flexible Pipe (Steel, DIP, CMP, and Tunnel Liner Plate)

a) Steel Pipe (Bored and jacked in place)

i) Spangler's Iowa formula shall be used for design with:

Deflection lag factor	-	$D_f = 1.5$
Modulus of soil reaction	-	$E' = 1080 \text{ psi}$
Bedding constant	-	$K_b = 0.096$
Soil loading constant	-	$K_u = 0.13$
Allowable deflection of pipe	-	3% of pipe diameter

b) Ductile Iron Pipe (Open Cut)

i) AWWA Specification C150 shall be used for design with:

Pipe laying condition = Type 3  
Earth load - ANSI A 51.50 prism method

c) Corrugated Steel Pipe & Corrugated Structural Steel Plate Pipe (Open Cut)

i) AREMA Chapter 1, Sections 4.9 & 4.10 shall be used for design with:

Soil stiffness factor -  $K = 0.33$   
Railroad impact as per Design Requirements-Casing Pipe Section of this specification.

d) Tunnel Liner Plate (Tunneled)

i) AREMA Chapter 1, Part 4, Section 4.16 shall be used for design with:

Soil stiffness factor -  $K = 0.33$   
Railroad impact as per Design Requirements-Casing Pipe Section of this specification.

### 3.3.2 Rigid Pipe (RCP, Vitrified Clay Pipe, and PCCP)

a) Reinforced Concrete Pipe, Vitrified Clay Pipe and Prestressed Concrete Cylinder Pipe (Open Cut)

i) American Concrete Pipe Association design manual shall be used for design with:

Marston load theory used for earth load

---

Bedding (Load Factor)	-	$L_f = 1.9$
Factor of safety	-	FS = 1.25 for RCP FS = 1.50 for VCP

Railroad impact as per Design Requirements-Casing Pipe Section of this specification.

**b) Reinforced Concrete Pipe (Jacked)**

**i) American Concrete Pipe Association design manual shall be used for design with:**

Marston load theory used for earth load

Bedding (Load Factor)	-	$L_f = 3.0$
-----------------------	---	-------------

Factor of safety = 1.25

Railroad impact as per Design Requirements-Design Loads Section of this specification.

Others – As approved by CSXT

### 3.4 Casing Pipe

#### 3.4.1 General Requirements

- a) Casing pipe shall be so constructed as to prevent leakage of any substance from the casing throughout its length, except at ends of casing where ends are left open, or through vent pipes when ends of casing are sealed. Casing shall be installed so as to prevent the formation of a waterway under the railroad, and with an even bearing throughout its length, and shall slope to one end (except for longitudinal occupancy).
- b) The casing pipe and joints shall be of steel and of leakproof construction when the pipeline is carrying liquid flammable products or highly volatile substances under pressure.
- c) The inside diameter of the casing pipe shall be such as to allow the carrier pipe to be removed subsequently without disturbing the casing or the roadbed. For steel pipe casings, the inside diameter of the casing pipe shall be at least 2 inches greater than the largest outside diameter of the carrier pipe joints or couplings, for carrier pipe less than 6 inches in diameter; and at least 4 inches greater for carrier pipe 6 inches and over in diameter.
- d) For flexible casing pipe, a maximum vertical deflection of the casing pipe of 3 percent of its diameter, plus ½ inch (13 mm) clearance shall be provided so that no loads from the roadbed, track, traffic, or casing pipe itself are transmitted to the carrier pipe. When insulators are used on the carrier pipe, the inside diameter of the flexible casing pipe shall be at least 2 inches greater than the outside diameter of the carrier pipe for pipe less than 8 inches in diameter; at least ¾ inches greater for pipe 8 inches to 16 inches, inclusive, in diameter and at least 4½ inches greater for pipe 18 inches and over in diameter.
- e) In no event shall the casing pipe diameter be larger than is necessary to permit the insertion of the carrier pipe.

- f) Casing pipe under railroad tracks and across CSXT's right-of-way shall extend the **greater** of the following distances, measured at right angle to centerline of track:
  - i) Across the entire width of the CSXT right-of-way.
  - ii) 3 feet beyond ditch line.
  - iii) 2 feet beyond toe of slope.
  - iv) A minimum distance of 25 feet from each side of centerline of outside track when casing is sealed at both ends.
  - v) A minimum distance of 45 feet from centerline of outside track when casing is open at both ends.
  - vi) Beyond the theoretical railroad embankment line. This line begins at a point 12 feet horizontally from centerline track, 18 inches below top-of-rail, and extends downward on a 1½ (H) to 1 (V) slope.
- g) If additional tracks are constructed in the future, the casing shall be extended correspondingly at the Owner's expense.

#### 3.4.2 Steel Pipe

- a) Steel pipe may be installed by open cut, boring or jacking depending on situation.
- b) Steel pipe shall have a specified minimum yield strength, SMYS, of at least 35,000 psi. The ASTM or API specification and grade for the pipe are to be shown on the Application Form.
- c) Joints between the sections of pipe shall be constructed to be capable of withstanding railroad loading. Joints can either be constructed through butt welding or through the use of interlocking joints.
- d) Steel casing pipe, with a **minimum** cover of 5.5 ft., shall have a minimum wall thickness as shown in Table 2, unless computations indicate that a thicker wall is required.

Table 2 – Steel Casing Pipe Wall Thicknesses

Pipe Diameter Nominal Pipe Size (in.)	Coated or Cathodically Protected Nominal Wall Thickness (in.)	Uncoated and Unprotected Nominal Wall Thickness (in.)
10 and under	0.188	0.188
12 & 14	0.188	0.250
16	0.219	0.281
18	0.250	0.312
20 & 22	0.281	0.344
24	0.312	0.375
26	0.344	0.406
28	0.375	0.438
30	0.406	0.469
32	0.438	0.500
34 & 36	0.469	0.532
38	0.500	0.562
40	0.531	0.594
42	0.562	0.625
44 & 46	0.594	0.657
48	0.625	0.688
50	0.656	0.719
52	0.688	0.750
54	0.719	0.781
56 & 58	0.750	0.812
60	0.781	0.844
62	0.812	0.875
64	0.844	0.906
66 & 68	0.875	0.938
70	0.906	0.969
72	0.938	1.000

- e) Coated steel pipe that is bored or jacked into place shall conform to the wall thickness requirements for uncoated steel pipe since the coating may be damaged during installation.
- f) For the required wall thicknesses on uncased steel carrier pipes conveying natural gas, refer to Uncased Pipelines Carrying Gas section in this document.
- g) Smooth wall steel pipes with a nominal diameter over 72 inches will not be permitted.

### 3.4.3 Ductile Iron Pipe

- a) Ductile iron pipe may be used only at the sole discretion of the Chief Engineer, Design and Construction when placed by the open cut method. Jacking or boring through the railroad embankment is not permitted due to the bell and spigot joints.
- b) Ductile iron pipe shall conform to the requirements of ANSI A21.51/AWWA C-151. Class 56 pipe shall be used unless computations, in accordance with the Design Requirements- Design Loads and Design Assumptions sections, are provided.

- c) Table 3 is based on the design assumptions given in the Design Requirements-Design Loads Section with a minimum cover of 5.5 feet. This table is provided for information only.

*Table 3 – Ductile Iron Pipe Wall Thicknesses*

Pipe Diameter (in.)	Thickness Class		Pressure Class
	Wall Thickness (in.)	Class	
3	0.25	51	350
4	0.25	51	350
6	0.25	50	350
8	0.25	50	350
10	0.26	51	350
12	0.28	51	350
14	0.31	52	350
16	0.34	52	350
18	0.36	53	350
20	0.38	53	350
24	0.42	55	350
30	0.49	56	350
36	0.56	56	350
42	0.63	56	350
48	0.70	56	350
54	0.79	56	350

- d) The pipe shall have mechanical or push on type joints.

#### **3.4.4 Corrugated Steel Pipe and Corrugated Structural Steel Plate Pipe**

- a) Corrugated steel pipe and corrugated structural steel plate pipe may be used for a casing only when placed by the open cut method. Jacking or boring through the railroad embankment is not permitted.
- b) Corrugated steel pipe and corrugated structural steel plate pipe may be used for a casing provided the pressure in the carrier pipe is less than 100 psi.
- c) Pipe shall be bituminous coated and shall conform to the current AREMA Specifications Chapter 1, Part 4.
- d) Corrugated steel pipe shall have a minimum sheet thickness as shown in Table 4. Corrugated structural steel plate pipe shall have a minimum plate thickness of 8 gage, 0.168 in. If computations indicate that a greater thickness is required, the thicker sheet or plate shall be used.

Table 4 – Corrugated Steel Pipe Wall Thicknesses

Pipe Diameter (in.)	Sheet Thickness	
	(Gauge)	(in.)
12 to 30	14	0.079
36	12	0.109
42 to 54	10	0.138
60 to 120	8	0.168

### 3.4.5 Steel Tunnel Liner Plate

- a) Liner plates shall be installed by the tunneling method as detailed in the Construction Requirements-Method of Installation section of this specification.
- b) Tunnel liner plates shall be galvanized and bituminous coated and shall conform to current AREMA guidelines. If the tunnel liner plates are used only to maintain a tunneled opening until the carrier pipe is installed, and the annular space between the carrier pipe and the tunnel liner is completely filled with cement grout within a reasonably short time after completion of the tunnel, then the tunnel liner plates need not be galvanized and coated.
- c) Tunnel liner plates are to be a minimum of 12 gage and shall be fabricated from structural quality, hot-rolled, carbon-steel sheets or plates conforming to ASTM Specification A 1011.
- d) The following liner plate information must be shown on the Application Form:
  - i) Number of flanges (2 or 4)
  - ii) Width of plate
  - iii) Type of plate (smooth or corrugated)

### 3.4.6 Reinforced Concrete Pipe

- a) Reinforced concrete pipe shall be installed by the open cut (at the sole discretion of the Chief Engineer, Design and Construction) or jacking method.
- b) Reinforced concrete pipe shall conform to ASTM Specification C 76. Class V pipe, Wall B or C shall be used unless computations, in accordance with the Design Requirements-Design Assumptions, are provided.
- c) Reinforced concrete pipe may be used for a casing provided the pressure in the carrier pipe is less than 100 psi.
- d) Pipe placed by open cut shall be installed in accordance with AREMA Guidelines except that backfill and compaction shall be in accordance with the Construction Requirements-Method of Installation section of this specification.



- e) Pipe jacked into place shall have tongue and groove joints and shall be installed in accordance with the Construction Requirements-Method of Installation section of this specification.
- f) Joints between sections of the RCP shall be sealed with a gasket conforming to ASTM C 443 or approved equal.

#### **3.4.7 Concrete Encasement**

- a) At locations where the installation is by open cut and a casing pipe is required, but cannot be installed due to elbows or other obstructions, concrete encasement may be used when approved by CSXT.
- b) The concrete encasement must provide a minimum cover of 6 inches of concrete around the pipe. A 6 x 6 - W 2.9 x W 2.9 welded wire fabric shall be placed in the concrete on all sides.

### **3.5 Carrier Pipe**

#### **3.5.1 General Requirements**

- a) The pipe shall be laid with sufficient slack so that it is not in tension.
- b) Steel pipe shall not be used to convey sewage, storm water, or other liquids that could cause corrosion.
- c) Carrier pipes located on CSXT's right-of-way or under tracks which CSXT operates, shall be manufactured in accordance with the following specifications:
  - i) Steel Pipe - The ASTM or API specification and grade for the pipe is to be shown on the Application Form. The specified minimum yield strength is to be at least 35,000 psi. For flammable substances, see the Design Requirements-Carrier Pipe Section of this document for additional requirements.
  - ii) Ductile Iron Pipe - ANSI A21.51/AWWA C151
  - iii) Corrugated Metal Pipe - AREMA Chapter 1, Part 4
  - iv) Reinforced Concrete Pipe - ASTM C 76
  - v) Vitrified Clay Pipe - ASTM C 700
  - vi) Prestressed Concrete Cylinder Pipe - AWWA C301
  - vii) Reinforced Concrete Cylinder Pipe - AWWA C300
  - viii) Others - As approved by CSXT.

- d) Carrier pipes installed within a casing pipe shall be designed for the internal pressure to which it will be subjected.
- e) Gravity flow carrier pipes, installed without a casing pipe, shall meet the requirements, of the particular pipe material, as given in Design Requirements-Casing Pipe Section of this specification.
- f) Design computations, stamped by a Professional Engineer, must be submitted for all uncased pressure pipelines installed on CSXT's right-of- way. The pipe must be designed for the internal and external loads (see the Design Requirements Section of this document) to which it may be subjected. The design assumptions given in Design Requirements Section shall apply.

### **3.5.2 Pipelines Carrying Flammable Substances**

- a) Products shall be of steel and conform to the requirements of the current ASME B 31.4 Liquid Transportation Systems for Hydrocarbons, Liquid Petroleum Gas, Anhydrous Ammonia, and Alcohols, and other applicable ASME codes, except that the maximum allowable stresses for design of steel pipe shall not exceed the following percentages of the specified minimum yield strength (multiplied by the longitudinal joint factor) of the pipe as defined in the above codes:
  - b) The following percentages apply to hoop stress in steel pipe within a casing under railroad tracks, across railroad right-of-way and longitudinally on railroad right-of-way:
    - i) Seventy-two percent on oil pipelines.
    - ii) Fifty percent for pipelines carrying condensate, natural gasoline, natural gas liquids, liquefied petroleum gas, and other liquid petroleum products.
    - iii) Sixty percent for installations on gas pipelines.
  - c) The following percentages apply to hoop stress in steel pipe laid longitudinally on railroad right-of-way without a casing:
    - i) Sixty percent for oil pipelines.
    - ii) Forty percent for pipelines carrying condensate, natural gasoline, natural gas liquids, liquefied petroleum gas, and other liquid petroleum products.
- d) Computations, based on the above requirements and stamped by a Professional Engineer shall be submitted with the application for occupancy.

### **3.5.3 Uncased Pipelines Carrying Gas**

- a) Pipelines carrying flammable and nonflammable gas products shall be steel and shall conform to the requirements of the current ASME B 31.8 Gas Transmission and Distribution Piping Systems, and other applicable ANSI codes.

- b) The minimum wall thickness for uncased carrier pipe shall be in accordance with the values provided in AREMA, Chapter 1, Part 5, Section 5.2.
- c) A durable coating, which will resist abrasion (fusion bonded epoxy or other suitable material), shall be used to protect the uncased pipeline when the boring method of installation is used.
- d) If CSXT determines there is the potential for damage to the uncased pipeline (foreign material in the subgrade, third party damage, etc.), special protection of the pipeline will be required. Special protection may include the use of concrete jacketed carrier pipe, a protection slab over the pipeline, increased depth of bury or other means.

### 3.6 Casing Pipe End Seals

- a) Casings for carrier pipes of flammable and hazardous substances shall be suitably sealed to the outside of the carrier pipe. Details of the end seals shall be shown on the plans.
- b) Casings for carrier pipes of non-flammable substances shall have both ends of the casing blocked up in such a way as to prevent the entrance of foreign material, but allowing leakage to pass in the event of a carrier break.
- c) The ends of a casing pipe may be left open when the ends are at or above ground surface and above high water level, provided drainage is afforded in such a manner that leakage will be conducted away from railroad tracks and structures.

### 3.7 Vents

- a) Sealed casings for flammable substances shall be properly vented. Vent pipes shall be of sufficient diameter, but in no case less than two inches in diameter, and shall be attached near each end of the casing and project through the ground surface at right-of-way lines or not less than 45 feet, measured at right angles from centerline of nearest track.
- b) Vent pipes shall extend not less than 4 feet above the ground surface. Top of vent pipe shall have a down-turned elbow, properly screened, or a relief valve. Vents in locations subject to high water shall be extended above the maximum elevation of high water and shall be supported and protected in a manner approved by CSXT.
- c) Vent pipes shall be at least 4 feet, vertically, from aerial electric wires or greater if required by National Electrical Safety Code (ANSI C2).
- d) When the pipeline is in a public highway, street-type vents shall be installed.

### 3.8 Signs

- a) All pipelines (except those in streets where it would not be practical to do so) shall be prominently marked at right-of-way lines (on both sides of track for crossings) by durable, weatherproof signs located over the centerline of the pipe. Signs shall show the following:
  - i) Name and address of owner

- ii) Contents of pipe
  - iii) Pressure in pipe
  - iv) Pipe depth below grade at point of a sign
  - v) Emergency telephone number in event of pipe rupture
- b) For pipelines running longitudinally on CSXT property, signs shall be placed over the pipe (or offset and appropriately marked) at all changes in direction of the pipeline. Such signs should also be located so that when standing at one sign the next adjacent marker in either direction is visible. In no event shall they be placed more than 500 feet apart unless otherwise specified by CSXT.
- c) The Owner must maintain all signs on CSXT's right-of-way as long as the occupational agreement is in effect.

### **3.9 Warning Tape**

- a) All pressure pipelines installed by the trench method, without a casing, shall have a warning tape placed directly above the pipeline, 2 feet below the ground surface.

### **3.10 Shut-off Valves**

- a) Accessible emergency shut-off valves shall be installed within 2,000 feet on both sides of the pipeline crossing or longitudinal occupancy.
- b) Steel pipelines conveying Natural Gas may exceed the 2,000 foot spacing requirement provided the following conditions are met:
  - i) The pipeline is equipped with Automatic or Remotely Controlled shut-off valves.
  - ii) Location of valves shall be in compliance with all State and Federal Regulations.
  - iii) The pipeline is monitored on a continuous, 24 hour - 365 day basis from a central control center.
  - iv) The pipeline operator shall provide CSXT with current emergency contact information

### **3.11 Cathodic Protection**

- a) Cathodic protection shall be applied to all pipelines carrying flammable substances on CSXT's right-of-way.

- b) For crossings and at other locations where the pipeline must be placed within a casing, the casing is to have cathodic protection or the wall thickness is to be increased to the requirements of the Design Requirements Section Table 2.
- c) Uncased gas carrier pipes must be coated and cathodically protected to industry standards and test sites, for monitoring the pipeline, provided within 50 feet of the crossing.
- d) Where casing and/or carrier pipes are cathodically protected by other than anodes, CSXT shall be notified and a suitable test made to ensure that other railroad structures and facilities are adequately protected from the cathodic current in accordance with the recommendation of current Reports of Correlating Committee on Cathodic Protection, published by the National Association of Corrosion Engineers.
- e) Where sacrificial anodes are used, the locations shall be marked with durable signs.

### **3.12 Manholes**

- a) Manholes shall not be located on CSXT property where possible. At locations where this is not practical, including longitudinal occupancies, manholes shall be precast concrete sections conforming to ASTM Designation C 478, "Specification for Precast Concrete Manhole Sections."
- b) The top of manholes located on CSXT property shall be flush with top of ground.
- c) The distance from centerline of adjacent track to centerline of proposed manhole shall be shown on the plans.

### **3.13 Box Culverts**

- a) Reinforced concrete box culverts shall be designed in conformance with CSX Standards and AREMA Guidelines.

### **3.14 Drainage**

- a) Occupancies shall be designed, and their construction shall be accomplished, so that adequate and uninterrupted drainage of CSXT's right-of-way is maintained.
- b) All pipes, ditches, and other structures carrying surface drainage on CSXT property and/or under CSXT track(s) shall be designed to carry the run-off from a one hundred (100) year storm. Plans submitted to CSXT for approval shall be prepared by a Professional Engineer and should indicate design, suitable topographic plan, and outline of total drainage area.
- c) If the drainage is to discharge into an existing drainage channel on CSXT's right-of-way and/or through a drainage structure under CSXT's track(s), the computations must include the hydraulic analysis of any existing ditch and/or structure.
- d) When calculating the capacity of existing or proposed drainage structures, under CSXT's track(s), the headwater calculation at the structure shall not be greater than one (1) pipe diameter.

- e) Pipe(s) used to carry surface drainage on CSXT's right-of-way shall have a minimum diameter of 24 inches.
- f) Detention ponds must not be placed on any part of CSXT's right-of-way. Also, the railroad embankment must not be used as any part of a detention pond structure.
- g) Formal approval of the proposed design, by the appropriate governmental agency having jurisdiction, shall be submitted with the drainage computations.

### 3.15 Pipelines on Bridges

- a) Pipelines **cannot** be installed on any bridge carrying CSXT tracks.
- b) Overhead pipe bridges will only be considered over CSXT right-of-way when underground installation of the pipeline is not possible. The Applicant must show that no practicable alternative is available and overhead pipe bridges will be permitted provided the conditions in Section 3.17 are met.
- c) Pipelines carrying flammable substances or non-flammable substances, which by their nature might cause damage if escaping on or near railroad facilities or personnel, shall not be installed on bridges over CSXT tracks. In special cases when it can be demonstrated to CSXT's satisfaction that such an installation is necessary and that no practicable alternative is available, CSXT may permit the installation and only by special design approved by the Chief Engineer, Design and Construction.
- d) When permitted, pipelines on bridges over CSXT tracks shall be so located as to minimize the possibility of damage from vehicles, railroad equipment, vandalism, and other external causes. They shall be encased in a casing pipe as directed by CSXT.

### 3.16 Cured-in-Place Pipes (CIPP)

- a) CIPP installations shall be designed in accordance with ASTM F1216 Appendix X1.
- b) CIPP to be installed in a casing pipe or an uncased carrier pipe shall be designed for a Fully Deteriorated condition. A Partially Deteriorated design condition will only be accepted for CIPP of carrier pipe that is already within a casing pipe. All CIPP calculations must be signed and sealed by a licensed Professional Engineer.
- c) CIPP designs will not be accepted when the wall thickness of the CIPP liner is greater than 2 inches.

### 3.17 Pipe Bridges / Conveyors

- a) The following are minimum requirements for the construction of pipe bridges:
  - i) The vertical clearance, distance from top of rail to closest component of structure, is shown and is a minimum of 23 feet, measured at a point 6 feet horizontally from centerline track.

- ii) The support bents for the overhead structure are located off CSXT's right-of-way or a minimum clear distance of 20 feet from centerline track, whichever distance is greater.
  - iii) Support bents within 25 feet of centerline track have pier protection in accordance with AREMA, Chapter 8 Section 2.1.5.
  - iv) Complete structural plans and design computations for the structure and foundations, sealed by a licensed Professional Engineer, are submitted with the application.
  - v) A fence (topped with barbed wire) or other measures are provided which will prevent access to the bridge by unauthorized personnel or vandals.
- b) The following are minimum requirements for the construction of conveyors:
- i) The vertical clearance, distance from top of rail to closest component of structure, is shown and is a minimum of 23 feet, measured at a point 6 feet horizontally from centerline track.
  - ii) The support bents for the overhead structure are located off CSXT's right-of-way or a minimum clear distance of 20 feet from centerline track, whichever distance is greater.
  - iii) Support bents within 25 feet of centerline track have pier protection in accordance with AREMA, Chapter 8 Section 2.1.5.
  - iv) Complete structural plans and design computations for the structure and foundations, sealed by a licensed Professional Engineer, are submitted with the application.
  - v) A fence (topped with barbed wire) or other measures are provided which will prevent access to the bridge by unauthorized personnel or vandals.
  - vi) Plan revisions, if applicable, are to include all proposed utilities attached to the proposed conveyor that do not service the conveyor.

**END OF PART 3**

**THIS PAGE BLANK**



## **PART 4 – CONSTRUCTION REQUIREMENTS**

### **4.1 Method of Installation**

#### **4.1.1 General Requirements**

- a) Bored, jacked, or tunneled installations shall have a bore hole essentially the same as the outside diameter of the pipe plus the thickness of the protective coating.
- b) The use of water or other liquids to facilitate casing emplacement and spoil removal is prohibited.
- c) If, during installation, an obstruction is encountered which prevents installation of the pipe in accordance with this specification, notify CSXT immediately, abandon the pipe in place, and immediately fill with grout. A new installation procedure and revised plans must be submitted to, and approved by, CSXT before work can resume.

#### **4.1.2 Bore and Jack (Steel Pipe)**

- a) This method consists of pushing the pipe into the earth with a boring auger rotating within the pipe to remove the spoil.
- b) The boring operation shall be progressed on a 24-hour basis without stoppage (except for adding lengths of pipe) until the leading edge of the pipe has reached the receiving pit.
- c) The front of the pipe shall be provided with mechanical arrangements or devices that will positively prevent the auger from leading the pipe so that no unsupported excavation is ahead of the pipe.
- d) The auger and cutting head arrangement shall be removable from within the pipe in the event an obstruction is encountered.
- e) The over-cut by the cutting head shall not exceed the outside diameter of the pipe by more than ½ inch. If voids should develop or if the bored hole diameter is greater than the outside diameter of the pipe (plus coating) by more than approximately 1 inch grouting (see the Construction Requirements-Grouting Section) or other methods approved by CSXT, shall be employed to fill such voids.
- f) The face of the cutting head shall be arranged to provide a reasonable obstruction to the free flow of soft or poor material.
- g) Plans and description of the arrangement to be used shall be submitted to CSXT for approval and no work shall proceed until such approval is obtained.
- h) Any method that employs simultaneous boring and jacking for pipes over 8 inches in diameter that does not have above approved arrangement **will not be permitted**. For pipe 8 inches and less in diameter, auguring or boring without this arrangement may be considered for use only as approved by CSXT.

#### 4.1.3 Jacking (RCP and Steel Pipe)

- a) This method consists of pushing sections of pipe into position with jacks placed against a backstop and excavation performed by hand from within the jacking shield at the head of the pipe. Ordinarily 36 inch pipe is the least size that should be used, since it is not practical to work within smaller diameter pipes.
- b) Jacking shall be in accordance with the current AREMA Guidelines, Chapter 1, Section 4.13, "Earth Boring and Jacking Culvert Pipe Through Fills." This operation shall be conducted without hand mining ahead of the pipe and without the use of any type of boring, auguring, or drilling equipment.
- c) Bracing and backstops shall be so designed and jacks of sufficient rating used so that the jacking can be progressed on a 24-hour basis without stoppage (except for adding lengths of pipe) until the leading edge of the pipe has reached the receiving pit.
- d) When jacking reinforced concrete pipe, a jacking shield shall be fabricated as a special section of reinforced concrete pipe with a steel cutting edge, hood, breasting attachments, etc., cast into the pipe. The wall thickness and reinforcing shall be designed for the jacking stresses.
- e) When jacking reinforced concrete pipe tapered for no smaller than 1½- inch pipe, grout holes shall be cast into the pipe at manufacture. Three grout holes equally spaced around the circumference and 4 feet longitudinally shall be provided for greater than 54 inches and smaller. Four grout holes equally spaced around the circumference and 4 feet longitudinally shall be provided for RCP 60 inches and larger.
- f) Immediately upon completion of jacking operations, the installation shall be pressure grouted as per Construction Requirements-Grouting Section of this specification.

#### 4.1.4 Tunneling (Tunnel Liner Plate)

- a) This method consists of placing rings of liner plate within the tail section of a tunneling shield or tunneling machine. A tunneling shield shall be used for all liner plate installations unless otherwise approved by CSXT.
- b) The shield shall be of steel construction, designed to support a railroad track loading as specified in the Design Requirements-Casing Pipe of this specification, in addition to the other loadings imposed. The advancing face shall be provided with a hood, extending no less than 20 inches beyond the face and extending around no less than the upper 240 degrees of the total circumference. It shall be of sufficient length to permit the installation of at least one complete ring of liner plates within the shield before it is advanced for the installation of the next ring of liner plates. The shield shall conform to and not exceed the outside dimensions of the liner plate tunnel being placed by more than 1 inch at any point on the periphery unless otherwise approved by CSXT.
- c) The shield shall be adequately braced and provided with necessary appurtenances for completely bulkheading the face with horizontal breastboards, and arranged so that the excavation can be benched as may be necessary. Excavation shall not be advanced beyond the edge of the hood, except in rock.

- d) Manufacturer's shop detail plans and manufacturer's computations showing the ability of the tunnel liner plates to resist the jacking stresses shall be submitted to CSXT for approval.
- e) Unless otherwise approved by CSXT, the tunneling shall be conducted continuously, on a 24-hour basis, until the tunnel liner extends at least beyond the theoretical railroad embankment line.
- f) At any interruption of the tunneling operation, the heading shall be completely bulkheaded.
- g) The liner plates shall have tapped grout holes for no smaller than 1½- inch pipe, spaced at approximately 3 feet around the circumference of the tunnel liner and 4 feet longitudinally.
- h) Grouting behind the liner plates shall be in accordance with the Construction Requirements-Grouting Section of this specification.

#### 4.1.5 Horizontal Directional Drilling

- a) **Installations by this method are considered a variance to CSXT Pipeline Occupancy Specifications.** but special consideration will be given where the depth of cover is substantial, 15 feet or greater, or the bore is in rock. Factors considered will be track usage, pipe size, contents of pipeline, soil conditions, boring equipment and procedures, etc. Reference the CSXT Interim Guidelines for Horizontal Directional Drilling (HDD) for additional information and instructions.

#### 4.1.6 Jack Conduit

- a) Installations by this method are generally not acceptable, but may be considered under special circumstances. This method consists of using hydraulic jacking equipment to push a solid steel rod under the railroad from a launching pit to a receiving pit. At the receiving pit, a cone shaped “expander” is attached to the end of the rod and the conduit (casing pipe) is attached to the expander. The rod, expander, and conduit are then pulled back from the launching pit until the full length of the conduit is in place.
- b) This method may be used to place steel conduit (casing pipe), up to and including 6 inches in diameter, under the railroad.
- c) The project specifications must require the contractor to submit, to CSXT for approval, a complete construction procedure of the proposed boring operation. Included with the submission shall be the manufacturer’s catalog information describing the type of equipment to be used.

#### 4.1.7 Open Cut – Not a readily accepted practice

- a) The Owner must request open cut approval when making application for occupancy. All procedures will be in compliance with AREMA Chapter 1 Section 5.1.5.1(b).
- b) Installations beneath the track by open trench methods will be permitted only with the approval of the Chief Engineer, Design and Construction.

- c) Installations by open cut will not be permitted under mainline tracks, tracks carrying heavy tonnage or tracks carrying passenger trains. Also, open cut shall not be used within the limits of a highway/railroad grade crossing or its approaches, 25 feet either side of traveled way, where possible.
- d) Rigid pipe (RCP, VCP, and PCCP) must be placed in a Class B bedding or better.
- e) At locations where open cut is permitted, the trench is to be backfilled with crushed stone with a top size of the aggregate to be a maximum of 2 inches and to have no more than 5% passing the number 200 sieve. The gradation of the material is to be such that a dense stable mass is produced.
- f) The backfill material shall be placed in loose 6 inch lifts and compacted to at least 95% of its maximum density with a moisture content that is no more than 1% greater than or 2% less than the optimum moisture as determined in accordance with current ASTM Designation D - 1557 (Modified Proctor). When the backfill material is within 3 feet of the subgrade elevation (the interface of the ballast and the subsoil) a compaction of at least 98% will be required. Compaction test results confirming compliance must be provided to CSXT's Regional Engineering Office by the Owner.
- g) All backfilled pipes laid either perpendicular or parallel to the tracks must be designed so that the backfill material will be positively drained. This may require the placement of lateral drains on pipes laid longitudinally to the track and the installation of stub perforated pipes at the edge of the slopes.
- h) Unless otherwise agreed upon, all work involving rail, ties, and other track material will be performed by railroad employees at the sole expense of the Owner, subject to advance payments by the owner.

#### 4.2 Grouting

- a) For jacked and tunneled installations a uniform mixture of 1:6 (cement: sand) cement grout shall be placed under pressure through the grout holes to fill any voids, which exist between the pipe or liner plate and the undisturbed earth.
- b) Grouting shall start at the lowest hole in each grout panel and proceed upwards simultaneously on both sides of the pipe.
- c) A threaded plug shall be installed in each grout hole as the grouting is completed at that hole.
- d) When grouting tunnel liner plates, grouting shall be kept as close to the heading as possible, using grout stops behind the liner plates if necessary. Grouting shall proceed as directed by CSXT, but in no event shall more than 6 lineal feet of tunnel be progressed beyond the grouting.

#### 4.3 Soil Stabilization

- a) Pressure grouting of the soils or freezing of the soils before jacking, boring, or tunneling may be required at the direction of CSXT Chief Engineer, Design and Construction to stabilize the soils, control water, prevent loss of material, and prevent settlement or displacement of embankment. Grout shall be cement, chemical, or other special injection material selected to accomplish the necessary stabilization.

- b) The materials to be used and the method of injection shall be prepared by a Licensed Professional Soils Engineer, or by an experienced and qualified company specializing in this work and submitted for approval to CSXT before the start of work. Proof of experience and competency shall accompany the submission.

#### **4.4 Dewatering**

- a) When water is known or expected to be encountered all plans and specification must be submitted to the Chief Engineer, Design and Construction for approval before the process begins. Pumps of sufficient capacity to handle the flow shall be maintained at the site, provided the contractor has received approval from CSXT to operate them. Pumps in operation shall be constantly attended on a 24-hour basis until, in the sole judgment of CSXT, the operation can be safely halted. When dewatering, a process for monitoring for any settlement of track or structures must be in place.

#### **4.5 Safety Requirements**

- a) All operations shall be conducted so as not to interfere with, interrupt, or endanger the operation of trains nor damage, destroy, or endanger the integrity of railroad facilities. All work on or near CSXT property shall be conducted in accordance with CSXT safety rules and regulations. Specifically all licensee's employees and agents, while on CSXT property, shall be required to wear an orange hard hat, safety glasses with side shields, 6" lace up boots with a distinct heel, shirts with sleeves, and long pants; additional personal protective equipment may be required for certain operations including abrasive cutting, use of torches, use of chainsaws, etc. The contractor and its employees shall comply with the CSXT safety rules at all times while occupying CSXT's property. Operations will be subject to CSXT inspection at any and all times.
- b) All cranes, lifts, or other equipment that will be operated in the vicinity of the railroad's electrification and power transmission facilities shall be electrically grounded as directed by CSXT. Use of a crane or other lifting equipment is subject to requirements as stated in the CSXT Public Projects manual.
- c) Whenever equipment or personnel are working closer than 25 feet from the centerline of an adjacent track, that track shall be considered as being obstructed. Insofar as possible, all operations shall be conducted no less than this distance. All operations shall be conducted only with the permission of, and as directed by, a duly qualified railroad employee present at the site of the work. All costs related to Railroad protection will be passed on to the applicant.
- d) Crossing of tracks at grade by equipment and personnel is prohibited except by prior arrangement with and as directed by, CSXT.

#### **4.6 Blasting**

- a) Blasting will not be permitted under or on CSXT's right-of-way.

#### **4.7 Temporary Track Supports**

- a) When the jacking, boring or tunneling method of installation is used, and depending upon the size and location of the crossing, temporary track supports shall be installed at the direction of CSXT.

- b) The Owner's contractor shall supply the track supports with installation and removal performed by CSXT employees.
- c) The Owner shall reimburse CSXT for all costs associated with the installation and removal of the track supports.

#### 4.8 Protection of Drainage Facilities

- a) If, in the course of construction, it may be necessary to block a ditch, pipe, or other drainage facility, temporary pipes, ditches, or other drainage facilities shall be installed to maintain adequate drainage, as approved by CSXT. Upon completion of the work, the temporary facilities shall be removed and the permanent facilities restored.
- b) Soil erosion methods shall be used to protect railroad ditches and other drainage facilities during construction on and adjacent to CSXT's right-of-way.

#### 4.9 Support of Excavation Adjacent to Track

##### 4.9.1 Launching and Receiving Pits

- a) The location and dimensions of all pits or excavations shall be shown on the plans. The distance from centerline of adjacent track to face of pit or excavation shall be clearly labeled. Also, the elevation of the bottom of the pit or excavation must be shown on the profile.
- b) The face of all pits shall be located a minimum of 25 feet from centerline of adjacent track, **measured at right angles to track**, unless otherwise approved by CSXT.
- c) If the bottom of the pit excavation intersects the theoretical railroad embankment line, interlocking steel sheet piling, driven prior to excavation, must be used to protect the track stability. The use of trench boxes or similar devices is not acceptable in this area.
- d) Design plans and computations for the pits, sealed by a Licensed Professional Engineer, must be submitted by the Owner at time of application or by the contractor prior to start of construction. If the pit design is to be submitted by the contractor, the project specifications must require the contractor to obtain approval from CSXT's Chief Engineer, Design and Construction prior to beginning any work on or which may affect CSXT property.
- e) The sheeting shall be designed to support all lateral forces caused by the earth, railroad and other surcharge loads. See Design Requirements- Design Loads for railroad loading.
- f) After construction and backfilling, all sheet piling within 10 feet of centerline track must be cut off 3' – 0" below final grade and left in place.
- g) All excavated areas are to be illuminated (flashing warning lights not permitted), fenced, and otherwise protected as directed by CSXT.

##### 4.9.2 Parallel Trenching and Other Excavation

- a) When excavation for a pipeline or other structure will be within the theoretical railroad embankment line of an adjacent track, interlocking steel sheet piling will be required to protect the track.
- b) The design and construction requirements for this construction shall be in accordance with the requirements of the Construction Requirements – Support of Excavation Adjacent to Track section of this document.

#### 4.9.3 Inspections and Testing

- a) For pipelines carrying flammable or hazardous materials, ANSI Codes, current at time of constructing the pipeline, shall govern the inspection and testing of the facility on CSXT property, except as follows:
- b) One hundred percent of all field welds shall be inspected by radiographic examinations, and such field welds shall be inspected for 100 percent of the circumference.
- c) The proof testing of the strength of carrier pipe shall be in accordance with ANSI requirements.

#### 4.9.4 Reimbursement of CSXT Costs

- a) All CSXT costs associated with the pipe installation (inspection, flagging, track work, protection of signal cables, etc.) shall be reimbursed to CSXT by the Owner of the facility. Estimates for Railroad costs will be provided to the Owner prior to the commencement of any work on Railroad right-of-way. **At CSX's option, CSX may require the funds to be paid in advance of any work being done.**

END OF PART 4

**THIS PAGE BLANK**



## **PART 5 – PUBLICATION STANDARDS SOURCES**

### **5.1 Publication Standards Sources**

*Table 5 – Publication Standards Sources*

Organization	Contact Information
ANSI	American National Standards Institute 1899 L Street, NW, 11 <sup>th</sup> Floor Washington, DC 20036 Tel: 202-293-8020
AREMA	The American Railway Engineering and Maintenance-of-Way Association 4501 Forbes Blvd., Suite 130 Lanham, MD 20706 Tel: 301-459-3200
ASTM	American Society for Testing and Materials PO Box C700 West Conshohocken, PA 19428-2959 Tel: 877-909-2786
AWWA	American Water Works Association 6666 West Quincy Avenue Denver, CO 80235 Tel: 1-800-926-7337
NACE	Then National Association of Corrosion Engineers Houston, TX USA 1-800-797-6223

- a) NOTE: If other than AREMA, ASTM, or AWWA specifications are referred to for design, materials, or workmanship on the plans and specifications for the work, then copies of the applicable sections of such other specifications referred to shall accompany the plans and specification for the work.

**END OF PART 5**



# STANDARD SPECIFICATIONS FOR THE DESIGN AND CONSTRUCTION OF PRIVATE SIDETRACKS

OFFICE OF:  
VICE PRESIDENT-ENGINEERING  
JACKSONVILLE, FLORIDA  
ISSUED: September 15, 2016

NOTICE TO USER: This manual has been prepared for the exclusive use of CSX Transportation's existing and potential customers, and their engineering consultants, for the design and construction of private sidetracks on properties operated by CSX Transportation. The information contained herein is subject to change without notice. It is the responsibility of the user to ensure that the latest version is being used for the design and construction of private sidetracks.

All persons entering the CSXT right-of-way during surveying and construction of the sidetrack shall follow all CSXT safety rules including wearing appropriate personal protective equipment to include safety glasses with side shields, hard hats, steel toe boots with distinct heel separation, and high visibility safety vests.

Current versions of this document may be obtained from  
CSX Transportation's [Industrial Development Department](#)

or online at CSXT's Website at  
[www.csx.com](http://www.csx.com)

by clicking on: Customers..Industrial Development..Site Design Guidelines and Specifications

Issued by:  
Office of the Vice President—Engineering  
CSX Transportation, Inc.  
500 Water Street—J350  
Jacksonville, Florida 32202

©2016—CSX Transportation, Inc.

# STANDARD SPECIFICATIONS FOR THE DESIGN AND CONSTRUCTION OF PRIVATE SIDETRACKS

## Table of Contents

<b>DESIGN .....</b>	<b>5</b>
A) GENERAL .....	5
B) ROADBED AND DRAINAGE .....	6
C) TRACK DESIGN.....	7
<b>Table 1: Turnout Geometry Data</b> .....	7
D) STRUCTURES .....	9
E) CLEARANCES .....	9
F) CROSSINGS.....	10
G) HAZARDOUS MATERIALS .....	12
H) DESIGN CRITERIA.....	14
<b>Table 2: Design Criteria</b> .....	14
I) PLANS FURNISHED BY INDUSTRY .....	15
Diagram: Clearance Diagrams (2604) .....	17
Diagram: Standard Clearance Matrix (2605).....	18
Diagram: Roadbed Sections (2601) .....	19
Diagram: Ballast Sections (2602).....	20
Diagram: Roadbed Sections and Grading for Industrial Track Turnouts (2603) .....	21
Diagram: Number 8 Turnout and Crossover (2220).....	22
Diagram: Number 8 Offset and Layout (2221) .....	23
Diagram: Number 10 Turnout and Crossover (2224).....	24
Diagram: Number 10 Offset and Layout (2225) .....	25
Diagram: 11'-0" Vertical Lift Derail (2252) .....	26
Diagram: Commercial Track A 640.6(2).....	27
Diagram: Loading or Unloading Combustible and Flammable Liquids or Flammable Gases .....	28
<b>CONSTRUCTION .....</b>	<b>29</b>
A) GENERAL .....	29
B) TIES.....	29
C) SPECIAL CONSIDERATION FOR WOOD AND COMPOSITE TIES .....	30
D) GAGE RODS.....	30
E) LAYING JOINTED RAIL .....	31
<b>Table 3: Expansion Required for Jointed Rail</b> .....	31
F) LAYING WELDED RAIL .....	32
G) SPIKING.....	32
H) SUPERELEVATION & SPIRALS.....	33
I) SURFACING & LINING TRACK .....	33
J) GRADE CROSSING .....	34
K) FINAL CLEANING .....	34
L) DERAILS AND BUMPING POSTS .....	34
M) GATES AND FENCES .....	34
N) INSPECTION .....	35
O) MAINTENANCE.....	35
Diagram: Main Track Spiking Patterns Side Track Spiking Patterns (2512).....	36
Diagram: Turnout Spiking Patterns with Bethlehem 811 Style Braces (2513) [sheet 1].....	37
Diagram: Turnout Spiking Patterns with Bethlehem Boltless Style Braces (2513) [sheet 2] .....	38
Diagram: Turnout Spiking Patterns with Clamptite Style Braces (2513) [sheet 3].....	39
Diagram: Joint Area Spiking Patterns (2514).....	40
Diagram: Light Duty Road Crossing--Bituminous Concrete with Rubber Panels (2521) .....	41
Diagram: Normal Road Crossing—Rubber, Asphalt, & Timber for Wood Ties (2535) [Sheet 1].....	42
Diagram: Normal Road Crossing—Rubber, Asphalt, & Timber for Wood Ties (2535) [Sheet 2].....	43
Diagram: Normal Road Crossing—Asphalt, & Timber for Wood Ties (2536) [Sheet 1] .....	44

Diagram: Normal Road Crossing—Asphalt, & Timber for Wood Ties (2536) [Sheet 2] .....	45
Diagram: Bridge Approach Ties (2607) .....	46

**GRADING ..... 47**

A) GENERAL .....	47
B) CLEARING AND GRUBBING.....	48
C) EXCAVATION .....	48
D) UNSUITABLE MATERIAL .....	49
E) EMBANKMENTS.....	49
F) DITCHES.....	50
G) FINISHED SUBGRADE.....	50
H) SUBBALLAST .....	50
I) GEOTEXTILES.....	50
J) PIPE CULVERTS .....	51
<i>Table 4: Corrugated Metal Pipe Specifications.....</i>	<i>52</i>
<i>Table 5: Elliptical Metal Pipe Specifications.....</i>	<i>52</i>
K) EROSION PROTECTION.....	53
L) TEMPORARY CROSSINGS .....	54
M) PROTECTION.....	54
N) SAFETY OF AND DELAY TO TRAINS.....	54
O) ACCESS .....	54

**MATERIALS..... 55**

A) GENERAL .....	55
B) SCOPE .....	55
C) SUBBALLAST.....	55
<i>Table 6: Subballast Gradation Requirements.....</i>	<i>55</i>
D) BALLAST.....	56
<i>Table 7: Track Ballast Gradation Requirements.....</i>	<i>56</i>
E) TIES.....	56
F) TIE PLATES .....	57
G) RAIL.....	57
H) TURNOUTS .....	58
I) DERAILS.....	59
J) BUMPING POSTS.....	59

## Design

### A) GENERAL

These guidelines are intended to provide information and guidance for the design and specifications for the construction of private railroad tracks and their supporting roadbeds. This document is intended to provide this information to industries and Contractors with varying degrees of experience in the design and construction of private tracks. The information provided, both general and specific, should **not** be considered as specifications, but may be used to assist in the preparation of specifications and preliminary drawings.

In general, the Industry shall construct, or cause to be constructed, all roadbed, ditches, drainage structures, and subballast required for the proposed track, **including** that of CSXT's ownership. When a proposed turnout is to be located in an existing CSXT owned track, CSXT will normally perform the construction of the turnout. CSXT will normally construct, own, and maintain the mainline turnout(s) and the portion of the sidetrack from the mainline turnout to and including the derail and/or the insulated joints. The Industry will normally construct, own, and maintain all remaining track from the CSXT ownership point into the rest of the industry. If the proposed turnout is located in an existing Industry owned track, Industry shall construct, own, and maintain this track. Final ownership and maintenance points will be determined by CSXT and shall be described in a Private Sidetrack Agreement that the Industry shall execute with CSX Transportation.

Industry shall provide, at no cost to CSXT, sufficient right of way for the construction and maintenance of CSXT owned track constructed on property beyond CSXT right of way. When industry owned track is constructed on CSXT right of way, CSXT will negotiate with the Industry for the occupancy of its property.

Industry shall furnish plans detailing track and roadbed design, drainage facilities, tipple details, building and loading dock sections, wire and pipeline crossings, car puller details, under track unloading pits, vehicle crossings (at grade or grade separations, public and private), etc., for design and clearance approval by CSXT. Preliminary plans should be submitted as early as possible to avoid potential problems and delay. The industry should attempt to provide for future expansion during the design and construction of their sidetrack. CSXT engineers are available for consultation during all phases of a track project. This service should be utilized for any questions that may arise.

Proper notification must be made to the appropriate Division personnel prior to industry entering CSXT right-of-way to construct roadbed or tracks. A separate right-of-entry agreement with CSXT will be required to access the right-of-way for surveying and preliminary engineering activities prior to execution of Sidetrack Agreement with CSXT. When construction operations are closer than twenty-five feet from the centerline of a CSXT track, a flagman from the appropriate CSXT Division will be assigned to the job site to protect industry or contract personnel, and CSXT personnel and property at the industry's expense. A flagman may also be required for activities involving cranes and other swinging equipment that has the potential to enter into the fouling limits of the track.

All persons entering the CSXT right-of-way during surveying and construction of the sidetrack shall follow all CSXT safety rules including wearing appropriate personal protective equipment to include safety glasses with sideshields, hard hats, high visibility safety vests, and steel toe boots with distinct heel separation.

## B) ROADBED AND DRAINAGE

### Roadbed

Roadbed width, ditches, and slopes shall conform to current **CSXT Standard Roadbed and Ballast Drawing 2601 and 2602 on pages 19 and 20**. State or local regulations, codes, etc., may require increased width of roadbed for walkways or other purposes.

*NOTE: The State of Tennessee requires walkway width extending for a distance of 10 feet from centerline of track on both sides. The walkway is to be level with the top of tie for a distance of 6 inches, and thereafter descending away from centerline at no greater than an 8 to 1 slope. The walkway, or fill-in ballast shall be comprised of material with an AREMA gradation #5.*

Roadbed for private track within CSXT right of way and parallel to a main or siding track shall be constructed a minimum of 6 inches lower than that of the nearest main or siding track whenever drainage of the existing track could be affected by the new construction. CSXT strongly recommends that private sidetracks be located on track centers of at least 25 feet from the centerline of an adjacent CSXT main and siding; however, private sidetrack leads and other tracks not used for bulk loading shall be no closer than 20 feet from the centerline of adjacent CSXT main or siding tracks.

All turnout locations require **additional roadbed** to support the track structure and to provide proper walkways for CSXT train crews. CSXT requires that the roadbed taper from the existing section 100-feet preceding the point of switch (P.S.) to 18 feet from the centerline at the P.S. The 18 foot roadbed is to extend from the P.S. to the transition with the 12 foot roadbed on the diverging track. **See CSXT Standard Drawing 2603, page 21, for typical subgrade section and grading required at turnout constructed in CSXT's and the industry's track.**

### Drainage

Design of the drainage system, including alterations of the existing drainage system on CSXT right of way, is the responsibility of the Industry. Drainage shall not be diverted, directed toward CSXT, or increased in quantity without prior approval and agreement with CSXT. All ditches, pipes, and culverts shall be adequately sized to carry the drainage without ponding of water against the roadbed (This shall be based on a 100 year storm). Track roadbed fills shall not be used as dams or levees for retention of water nor shall CSXT right of way be utilized for retention or settling basins. All drainage facilities must be shown on the drawings submitted by the industry.

Pipes and culverts shall conform to current AREMA Recommendations and ASTM Specifications. All such structures shall be designed to carry Cooper's E-80 loading with diesel impact. Reinforced concrete pipe under CSXT owned track shall be ASTM C-76, Class V, with "O" ring joints. Corrugated metal pipe under CSXT owned track shall be steel fiber bonded and asphalt coated or steel polymer pre-coated, with minimum 24 inch wide connecting bands. The minimum recommended diameter of pipe under CSXT owned track is 36 inches.

Extension of pipes, culverts, or other drainage structures previously installed under CSXT owned track shall be made with culvert or drainage structures having the same size, shape, and dimensions as the existing pipe. In no case shall the existing drainage structure be extended so that the hydraulic capacity is decreased or obstructed. In some cases, it may be necessary to extend existing outlets with pipe or culvert of a larger size. Details of connections to mismatched culverts shall be submitted for CSXT approval.

C) TRACK DESIGN

Turnout Definitions

**Point of Switch (P.S.):** The point at which a track begins to diverge from another

**Point of Intersection (P.I.):** As applied to turnouts, the point of intersection of the centerlines of the diverging track and the through track

**Point of Frog (P.F.):** The point at which two running rails intersect within a turnout or crossing

**Heel of Frog:** The end of the frog that is furthest away from the point of switch.

Turnouts

A turnout (T.O.) consists of all parts of the track structure, including switch points, frog, rails, switch ties, fastenings, etc., necessary to connect one track to another. Turnouts are designated by the size of the frog contained in the turnout. Turnouts to be installed and maintained by CSXT in its tracks must be No.10 or larger. Turnouts installed for private sidetracks must be No.8 or larger in industry tracks and No.10 or larger in industry owned lead tracks. Turnouts for unit train facilities must be No.10 or larger. Turnouts installed on industrial sidetrack shall include switch point guards.

**See CSXT Standard Drawings, pages 22 through 25, for design data for CSXT Standards for No. 8 and No.10 turnouts.**

A turnout must **not** be designed as a simple curve. **Table 1** provides dimensions for laying out turnouts on plans using point of intersection and turnout angle. This method is a simple and acceptable way of representing turnouts on plans. Local conditions, including curves or the use of long cars or special equipment, may require the use of larger size turnouts.

**Table 1: Turnout Geometry Data**

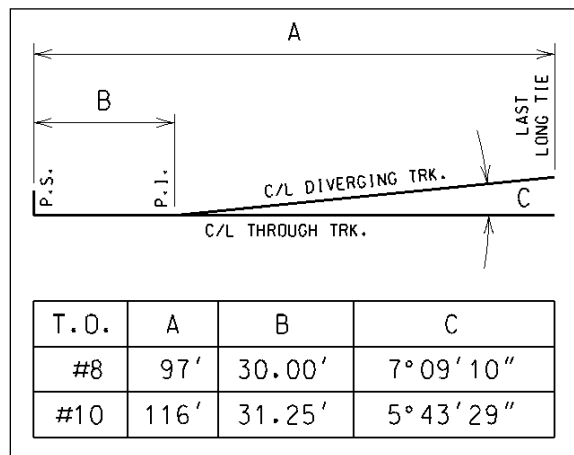

On CSXT main track, the location of any portion of a turnout shall not be located within **200 feet of curves, road crossings, railroad bridges, tunnels, or other turnouts**. On other tracks, this distance may be reduced to 50 feet. If the turnout is located within 500 feet of a bridge, a walkway meeting CSXT's standards is required on the bridge to accommodate switching operations.



## Horizontal Curves

Track should be designed using the minimum degree (maximum radius) of curve practicable. Special circumstances, including the use of long cars or special equipment, may require a lesser degree of curvature. Sharper curves may restrict the size of locomotives and opportunity to provide timely switching service due to locomotive restrictions. While a maximum curvature of 10° (radius of 573.69') is highly recommended, under no circumstance without written approval of the Assistant Vice President Engineering - Design and Construction, will the degree of curvature for the track exceed 12° (radius of 478.34').

Typically, railroads use the chord definition of degree of curve. This defines degree of curve as, **the central angle subtended by a 100-foot chord. The degree of curve is denoted by  $D_c$ , where**

$$\sin(\frac{1}{2}D_c) = 50/r$$

and **r is the radius of the curve.**

Wherever practicable, a curve should begin beyond the last switch tie, but, if required by special circumstances, a curve may extend onto the switch ties. In no case shall a curve begin between the point of switch and the heel of frog. A curve should be avoided at the loading point of a bulk loading facility or at an under track unloading structure.

Spiral curves and superelevation are not normally required on industry tracks but, if required by special circumstances, shall be designed according to current CSXT standards.

Horizontal reverse curves (curves following each other in opposite directions) shall be separated by a minimum 100 feet of tangent (straight sections) as specified in “**Design Criteria**” on page 14.

## Grades and Vertical Curves

Track grades shall be minimized where possible, consistent with terrain requirements. Grades must be carefully designed to ensure that motive power available will handle the tonnage to be moved. This takes into consideration number of cars, whether loaded or empty, etc. Grades for unit train tracks should be designed so that a train is under power with no bunching of couplers while loading or unloading. Frequent changes of grade are to be avoided. Vertical curves shall be provided at all grade changes, and shall be as long as practicable. Minimum standards for calculation of vertical curves are specified in “**Design Criteria.**”

Grades shall be compensated for curvature at the rate of 0.04% for each degree of curvature. For example, the maximum allowable grade on a 10 degree curve for a Load / Unload in motion track is 1.5% - (10 x 0.04) = 1.1% grade in the 10 degree curve.

Grades, including compensation, shall not exceed 2.5% on industry and lead tracks, 1.5% on unit train tracks, and 0.7% on loop tracks.

The section of a track where railcars are placed for loading and unloading shall have a 0.00% grade.

**Neither grade changes nor vertical curves shall be within the limits of switch ties.**

## Derails and Bumping Posts

CSXT approved derails will be installed at or near the clearance point of all turnouts entering CSXT's tracks. **See CSXT 11"-0" Vertical Lift Derail Standard Drawing 2252 on page 26.** Derails shall be placed so that a car will derail away from, and before it fouls, the track being protected, or damages the building intended to be protected.

The P.S. of switch point derails shall be located no closer than 50 feet beyond the 15 feet clearance point. Note that additional distance may be required depending on the severity of a descending grade and the track configuration.

A bumping post shall be installed at the end of all tracks. A bumping post is used when the track ends short of a structure, roadway, or public area that must be protected from cars rolling or being pushed beyond the end of the track. In most industrial situations, a bumping post offers adequate protection. However, cars loaded or empty, rolling or being pushed at an excessive speed will not be stopped by a bumping post. Other protective measures should be taken to supplement the bumping post. Wheel stops should be used only to prevent a standing car from beginning to roll. A rolling car or one being pushed most likely will not be stopped by wheel stops making them ineffective for Industries where cars are typically moved. Earthen barriers may be used for mine tracks only.

## D) STRUCTURES

All bridges, trestles, box culverts, unloading pits, conveyors, etc., shall be designed under the authority of a licensed professional engineer familiar with and in accordance to the American Railway Engineering and Maintenance-of-Way Association's *Manual for Railway Engineering* (latest edition published annually—see [www.arena.org](http://www.arena.org) for details on obtaining the manual) chapters 7 (timber), 8 (concrete), and 15 (steel structures), using a live load of Cooper E-80 with full diesel impact. For a new bridge constructed over the track, minimum clearances are 23 feet vertical (measured from top of highest rail) and 18 feet total horizontal (9 feet either side of the centerline of track). The proposed design for bridges, trestles, box culverts, unloading pits, conveyors, etc. shall be reviewed by CSXT prior to construction. Walkway grating shall be securely fastened to the structure with each piece of grating fastened to at least three bearing surfaces. Crash walls may be required for overhead structures located less than 25 feet from the centerline of track. To avoid delay, plans should be forwarded to CSXT allowing sufficient time for review.

Design and construction of track scales shall be conducted under the authority of a licensed professional engineer familiar with and in accordance with the American Railway Engineering and Maintenance-of-Way Association's *Manual for Railway Engineering* and the Association of American Railroads *AAR Scale Handbook*.

## E) CLEARANCES

All fixed or movable obstructions above or adjacent to tracks shall provide horizontal and vertical clearance as required by applicable State or Local laws or regulations, or by CSXT current Standards, whichever is greater. **See CSXT Clearance Diagrams, pages 17 through 18.** Clearances shall be increased to compensate for curvature and superelevation as specified.

Lesser clearances must have the approval of CSXT and the appropriate governmental agency. Any clearances less than CSXT standard shall be considered a substandard (close) clearance. CSXT will require signs or markings to warn CSXT employees of approaching substandard clearances. The close

clearance sign shall be illuminated at night. All substandard clearances and associated liabilities will be noted in the sidetrack agreement.

The distance between adjacent tracks is also subject to legal and CSXT clearance requirements. CSXT strongly recommends that private sidetracks be located on track centers of at least 25 feet from the centerline of adjacent CSXT main and siding or sidings; however, private sidetrack shall be no closer than 20 feet from the centerline of adjacent CSXT main or siding tracks. The minimum distance to other tracks is shown on **Standard Clearance Matrix, page 18**. The centerline of a bulk-loading/unloading track shall not be less than 27 feet, at the loading/unloading point, from the centerline of an adjacent main or siding track. **No portion of a loading/unloading structure shall be closer than 18 feet from the centerline of the nearest main or siding track.** The above minimum 27 feet bulk loading/unloading track center is to be adjusted upward to accommodate for the actual size of the portion of the loading structure between the tracks, while observing the required minimum 8'-0" and 18'-0" lateral track clearances, respectively, for the loading/unloading track and the main or siding tracks.

## F) CROSSINGS

### Track Crossings At Grade

Designs involving one track crossing another at grade are prohibited without written approval of the AVP Engineering – Design and Construction.

### Roadway Crossings At Grade

Road crossings at grade must be designed to provide proper sight distances and may require other safety measures such as automatic grade crossing warning devices (flashing lights, gates, etc.). A triangular sight distance envelope must be maintained for 300 feet along the track either side of the crossing and 100 feet along the road from the nearest track; the sight distance shall be maintained to a height of 3.75 feet above the pavement. Existing crossings shall be eliminated whenever possible and new roadway crossings are not permitted without written approval from CSXT. In the event that a private roadway is required that crosses CSXT owned track, it must be covered by a separate agreement. Information on obtaining the agreement may be obtained from CSXT's website at: [www.csx.com](http://www.csx.com). If CSXT is the maintaining railroad, CSXT is responsible to place an Emergency Notification Sign at each crossing, (if 'Public' two signs: one at each approach, if 'Private' one sign at the crossing). If the track is within a Port, Yard or an Industry then the maintaining railroad is required to place one sign at each vehicular entrance to the facility, (Note: Only one DOT number is required for the entire facility). If CSXT does not maintain the crossing but operates trains through the crossing, then the maintaining railroad must put the CSXT 1-800-232-0144 number as noted above.

In order to request a new DOT number; a current copy of FRA Form F 6180.71 must be completed and submitted to the [crossingrequests@csx.com](mailto:crossingrequests@csx.com) email address so a record can be created and logged with the FRA. The form can be downloaded from the FRA website at [www.fra.dot.gov](http://www.fra.dot.gov) and search for Form F6180.71.

New track crossings of public roads involve obtaining permission from governmental agency having jurisdiction, and often require detailed plans, public hearings, etc. Both public and private crossings with CSXT tracks shall conform to CSXT standards and be constructed of asphalt with timber flangeway and filler blocks, unless a higher type crossing (full rubber, slab, concrete, etc.) is desired by the Industry or required by the governmental agency. The materials used for road crossings must conform to CSXT's specifications. Plans for roadway crossings must be submitted to CSXT for approval.

If automatic grade crossing warning devices are required by CSXT or a governmental agency, plans of control apparatus, equipment, and method of installation are subject to review and approval of CSXT and

the governmental agency. The entire cost of installation and ongoing maintenance of crossing warning devices shall be borne by the industry.

Track design must provide proper clearance at grade crossings. Railroad cars or other equipment must not stand or be left within 200 feet of any crossing. Some state statutes may require additional clearance requirements; check with the CSXT Industrial Development Site Design Manager for additional details.

#### Stream and Public Drain Crossings

Complete plans for culverts, bridges, trestles, or other drainage structures must be approved by CSXT and appropriate governmental agencies, and required permits obtained, before construction. CSXT requires the drain system to be designed for 100 year storm. Plans for all structures shall bear the seal of a licensed professional engineer in the state of the project.

#### Wireline and Pipeline Crossings

Each wireline, pipeline, or fiber optic cable crossing or running parallel to tracks owned and maintained by CSXT must be covered by a separate agreement between the industry and the CSXT. These utility installations shall conform to CSXT's standards for installation of Pipelines and Wirelines as appropriate. The industry should obtain a copy of the CSXT application form for the installation of wireline and pipeline crossings, and parallelisms from [www.csx.com](http://www.csx.com).

Proper notification must be made to the appropriate Division personnel prior to industry entering CSXT right-of-way to construct such crossing. A flagman from the appropriate Division will be assigned to the job site to protect industry or contract personnel, and CSXT personnel and property. Instructions and reimbursement information for the flagman will be given through the wireline and pipeline agreement process.

#### Pipelines

Pipeline crossings and installations parallel to a track shall conform to the current CSXT standards for installation of pipelines on CSXT right of way.

All pipeline installations on CSXT right-of-way and at industry's expense, must be approved by CSXT prior to any construction. The industry must submit complete plans for all proposed pipelines that will cross land and tracks owned and maintained by CSXT, and tracks owned by others (sidings, industry tracks, etc.) over which CSXT operates.

#### Wirelines

Electric power line clearances, both overhead and lateral, shall conform to CSXT Standards and the National Electric Safety Code. All wireline installations on CSXT right-of-way must be approved by CSXT prior to any construction. The industry must submit complete plans meeting CSXT standards for installation of wirelines on CSXT right of way for all proposed wirelines that will cross under tracks owned and maintained by CSXT, and tracks owned by others (sidings, industry tracks, etc.) over which CSXT operates.

#### Fiber Optic Cable

Underground Fiber Optic Cable installations (longitudinal occupations on CSXT property) may require relocation, lowering, and/or protective casing installation. CSXT's Engineering representative will contact the Fiber Optic Company to arrange for relocation, lowering, and/or protection of the Fiber Optic Cable at the discretion of the Fiber Optic Company.

### Other Crossings

Any other crossing including, but not limited to conveyor crossings - both over and under the tracks - must conform to the same clearance requirements as overhead bridges. Plans must be submitted for CSXT approval and must be covered by a separate agreement.

### G) HAZARDOUS MATERIALS

The loading, unloading, and storage of hazardous materials may require special design of tracks. Minimum clearances, minimum distances from storage facilities to track, bonding, and grounding of track, etc. must be considered when designing tracks for the handling of hazardous materials.

### Definitions

**Active Track** Any main, siding, or other track owned by CSXT and any other track over which the speed of trains on the track exceed 15 MPH.

**Hazardous Material** - A substance or material which has been determined by the Secretary of Transportation to be capable of posing an unreasonable risk to health, safety, and property when transported in commerce and which has been so designated in Title 49 of the Code of Federal Regulations (49CFR105 and 172).

**Terminal** - The location and operation point where loading and/or transfer of the above-mentioned commodities takes place.

**Transfer** - The process of unloading from a railroad tank car(s) into fixed storage facilities and unloading from fixed storage facilities into railroad tank car(s). The term also refers to the process of loading or unloading railroad tank cars directly into or from truck transport trailers.

**Transfer point** - Location of point where transfer hose or apparatus is connected to transfer vehicle or device.

### Location of tracks

Distances from any active railroad track to any facility/installation for transferring from tank car(s) or storage of hazardous materials, must be taken from the center of the railroad track in question to the nearest boundary of the transfer facility or material storage area(s).

### Separation Distance for New Facilities

Transfer point for PIH, Class 3, Division 2.1, Division 2.2, and all other Hazard Classes must be located at least 100 feet from an active track(s).

Transfer point for Combustible liquids, Class 8 and 9 must be located at least 50 feet from an active track(s).

In transferring hazardous materials, the tank car(s) and storage tank(s) must be so constructed as to effectively permit a free flow of vapors from the tank car to the storage tank and to positively prevent the escape of these vapors to the air, or the vapors must be carried by a vent line to a point not less than 100 feet from the nearest occupied building, or active track(s).

Preferably, the site should be located on ground that slopes away from active tracks. Whenever possible, transfer equipment shall be placed on the same side of the private tracks as the storage tanks to avoid crossing under or over such tracks. This equipment should be located on the same side of the tracks as the access/egress highway to minimize the crossing of said tracks with trucks providing service.

Hazardous Materials Terminals must be sloped and contoured to contain any spills within the transfer area. In addition, track pans or other type of acceptable containment system must be installed to contain spilled material and prevent contamination of underground water sources.

Customer must isolate transfer point tracks from rail movement during transfer operations. This shall be accomplished by locking a derail or facing point turnout restricting movement into the transfer operation.

#### Storage of Loaded Hazardous Material Tank Cars

Storage tracks for PIH, Class 3, Division 2.1, Division 2.2, and all other Hazard Classes must be located at least 50 feet from an active track(s).

Storage tracks for combustible liquids, Class 8 and 9 must be located at least 25 feet from an active track(s).

#### Bonding and Grounding

Tracks constructed to handle hazardous materials must be bonded and grounded as per **CSXT drawing number SS500, page 28.**

H) DESIGN CRITERIA

Design criteria to be used for sidetracks with operating speeds not to exceed 15 mph are listed in the following table. The criteria are not intended for Yard and Terminal track, Intermodal track, Branch or Spur Lines, nor any track with operating speed greater than 15 mph.

**Table 2: Design Criteria**

<b>CRITERIA</b>	<b>INDUSTRY TRACK</b>	<b>INDUSTRY LEAD TRACK</b>	<b>UNIT TRAIN TRACK</b>
<b>Turnout Size</b>	Number 8	Number 10	Number 10
Note: turnouts in all CSXT owned tracks shall be Number 10 or larger			
<b>Maximum Horizontal Curvature</b>			
Degree	12°-00'-00"	10°-00'-00"	10°-00'-00"
Radius	478.34'	573.69'	573.69'
(Chord Definition: $r = 50 / \sin(D/2)$ )			
<b>Tangent Between Horizontal Reverse Curves</b>			
Minimum	100'	100'	100'
<b>Maximum Grade</b> (total grade including compensation in curves)			
	2.5%	2.5%	1.5%
Loop Track	--	--	0.7%
(note: Compensation rate is 0.04% per degree of curve)			
<b>Vertical Curve</b>			
Summits	40 x algebraic difference in grades	40 x algebraic difference in grade	400 x algebraic difference in grades
Sags	50 x algebraic difference in grades	50 x algebraic difference in grades	500 x algebraic difference in grades
Length	100' minimum	100' minimum	100' minimum

## I) PLANS FURNISHED BY INDUSTRY

To expedite review procedure, plans produced by industry or its consultant shall be provided to the appropriate CSXT office in Portable Document Format (.pdf) and MicroStation (.dgn), along with all reference and supporting files. Electronic files will be forwarded on a USB memory stick or via email (email attachments are subject to a 5.0Mb file size). A sheet should be included listing levels or layers used and their descriptions; instructions regarding reference files or special cell libraries shall also be included on the sheet. Printed plan sets shall be furnished to CSXT upon request.

Plans provided to CSXT should include a track layout drawing to be made part of the agreement covering the new track(s). The drawing shall be a convenient scale and shall be no larger than 11" x 17".

All stationing and dimensions on plans provided to CSXT shall be placed using English decimal measurements; plans submitted in metric will not be reviewed.

Plans submitted by the Industry or its consultant for CSXT review and approval should include, but are not limited to, the following:

Plans shall be drawn to scale and show all important features effecting track layout. Preferred scale is 1 inch = 100 feet, but a minimum scale of 1 inch = 200 feet may be used for large projects.

Plans shall show true magnetic North, city, county, township, state, and other information necessary to locate the site. The plan shall be oriented so that north is to the top or right side of the drawing.

Tracks shall be drawn as a single line representing the **centerline** of track (do **not** draw track showing the rails or crossties). Existing track shall be shown as solid lines with light line weight. Proposed track shall be shown as solid lines with heavy (bold) line weight. Track to be removed or relocated shall be shown as light dashed lines (existing location) and as bold solid lines (proposed location).

Show elevations and locations of proposed and existing buildings (floor elevations), docks, loading pads, loading and unloading points, under track or overhead conveyors, and drainage structures. Show distance above top of rail to overhead utilities (including company name and phone number). Show distance below top of rail to underground utilities (including company name and phone number). Also, include fiber optic cables, CSXT's signal, communication and electric wirelines, and other facilities adjacent to the tracks, showing stationing at the beginning and end of each facility.

Appropriate property lines and the proposed point of switch (PS) - the point where the proposed track begins to diverge from the existing track - must be referenced by the distance to the nearest CSXT railroad milepost. The reference shall be the distance to the nearest milepost including the prefix of the milepost if known. The location of the milepost or the direction and distance to the milepost shall be noted on the drawing. Stationing shall be provided where track crosses right-of-way lines.

Stationing (measurement along the track centerline) shall be used to locate all points of horizontal and vertical design and all existing or proposed structures. Stationing shall be continuous along each track starting with 0+00 at its point of switch and increasing to its end. Therefore, the PS of each track will have two stations: its own (0+00) and the station of the track from which it diverges. Sufficient length shall be provided in tracks to allow variability in freight car lengths and for spotting cars on tracks.

Curve information for each curve shall include the intersection angle (I), degree of curve ( $D_c$ ), radius (R), tangent distance (T), external (E), and length of curve (L). Chord definition of curvature shall be used:  $R = 50/\sin(D_c/2)$  and  $L = 100(I/D)$ .



If known at the time of the design, show size and weight of rail of proposed turnout, and weight of rail and type of construction (welded rail or jointed rail) in the proposed track and in the existing track from which the proposed track diverges. If the rail weight is unknown, the statement “minimum acceptable rail section is 100 pound/yard” should be shown on the drawing. The industry should note that based on market availability, larger rail sections are frequently available for lower costs than smaller rail sections; additionally, use of larger rail sections may reduce track maintenance costs to the industry over time. **Also note that non-controlled cooled rail shall not be used in industrial sidetracks.**

Plans shall include top of rail and subgrade profile of the entire proposed track showing vertical curves at points of vertical intersection with their proposed lengths and station location, ground profile and drainage structures. Profile shall also include the top of rail profile of the existing track from which the proposed track diverges with elevations taken every 100 feet for a distance of 300 feet each side of the proposed point of switch. Where superelevated curves exist, the top of rail elevation of the low rail shall be the given elevation. **All proposed tracks must have the same grade, and elevation between the PS and the end of switch ties as the track from which they diverge.**

Plans shall show size, type and location of all proposed and existing drainage structures and ditches in the immediate vicinity of the proposed and existing track and how drainage will be directed to protect the tracks.

Stations and horizontal clearances from the centerline of track must be shown for all structures or obstructions within 25 feet of the centerline of any track. Stations and vertical clearances measured from top of rail (high rail in curves) must be shown for all overhead obstructions.

Some track layouts may require separate, more detailed drawings and/or information. Examples of these are bridges, box culverts, large drainage structures, tunnels, unloading pits, track scales, facilities for handling hazardous materials, structures with less than standard clearances, road crossings, crossing protection devices, pipeline crossings, wireline crossings, unconventional track construction, track, or other construction in close proximity to CSXT track, encroachments on CSXT right of way, or purchase or lease of land from CSXT.

Some of the above information such as stationing, mileposts, rail weight, etc. may not be obvious or obtainable from a field survey. The industry or Contractor should contact the CSXT Industrial Development Site Design Manager or the Engineering office responsible for the territory involved for any information regarding these items. CSXT Engineers can also provide information or guidance regarding any special features or situations that may exist at the site.

2604

1. STANDARD CLEARANCES ARE TO BE USED FOR ALL NEW CONSTRUCTION WHERE THERE ARE NO LEGAL REQUIREMENTS THAT DICTATE GREATER CLEARANCES.
2. CLEARANCES FOR RECONSTRUCTION, REHABILITATION AND ALTERATION WORK ARE DEPENDENT ON EXISTING PHYSICAL CONDITIONS, WHERE POSSIBLE, THEY WILL BE IMPROVED TO COMPLY WITH THE STANDARD CLEARANCES.
3. STATE OR CANADIAN CLEARANCE LAWS MUST NOT BE VIOLATED. LEGAL REQUIREMENTS MAY BE MODIFIED ONLY BY THE GOVERNMENTAL BODY THAT ISSUED THEM.
4. STANDARD CLEARANCE MAY BE MODIFIED ONLY IF APPROVED BY THE CHIEF ENGINEER DESIGN, CONSTRUCTION, AND CAPACITY.
5. STANDARD CLEARANCE DIAGRAMS SHOWN ARE FOR TANGENT TRACK AND INCREASES MUST BE PROVIDED FOR THE EFFECTS OF CURVATURE AND SUPERELEVATION.

A. ADDITIONAL CLEARANCE DUE TO CURVATURE:  
 WHEN A FIXED OBSTRUCTION IS LOCATED ADJACENT TO A CURVED TRACK, THE HORIZONTAL CLEARANCE WILL BE INCREASED 1 1/2 INCHES PER DEGREE OF CURVATURE ON BOTH SIDES OF THE TRACK CENTERLINE PER TABLE 1. EXCEPTION: FLORIDA REQUIRES 2 INCHES PER DEGREE.

B. ADDITIONAL CLEARANCE DUE TO SUPERELEVATION:  
 WHEN A FIXED OBSTRUCTION IS LOCATED ADJACENT TO A SUPERELEVATED TRACK, THE HORIZONTAL CLEARANCE ON THE LOW RAIL SIDE OF THE TRACK WILL BE INCREASED TO ALLOW FOR TILT. THE MINIMUM INCREASE IS SHOWN ON GRAPH NO. 1.

C. ADDITIONAL CLEARANCE DUE TO CURVATURE AND SUPERELEVATION:  
 WHEN A FIXED OBSTRUCTION IS LOCATED ADJACENT TO A CURVED AND SUPERELEVATED TRACK, THE HORIZONTAL CLEARANCE INCREASE WILL BE THE SUM OF THE INCREASES OBTAINED LISTED 5. A AND 5. B ABOVE. EXCEPTION: CANADA REQUIRES A MINIMUM OF 2 INCHES PER DEGREE.

D. ADDITIONAL CLEARANCE ON TANGENT TRACKS:  
 WHEN A FIXED OBSTRUCTION IS ADJACENT TO TANGENT TRACK BUT THE TRACK IS CURVED WITHIN 80 FEET OF THE OBSTRUCTION, THE HORIZONTAL CLEARANCE WILL BE INCREASED AS FOLLOWS:

DISTANCE FROM OBSTRUCTION TO CURVED TRACK - FEET	INCREASED HORIZONTAL CLEARANCE
0 TO 20	100% OF PARAGRAPH 5.C
21 TO 40	75% OF PARAGRAPH 5.C
41 TO 60	50% OF PARAGRAPH 5.C
61 TO 80	25% OF PARAGRAPH 5.C

6. VERTICAL CLEARANCE ON SUPERELEVATED TRACK IS MEASURED FROM THE TOP OF THE HIGH RAIL.



CLEARANCE DIAGRAMS

APPROVED - CHIEF ENGINEER DESIGN, CONSTRUCTION, & CAPACITY  
*Deb W. Ophardt*  
 APPROVED - VICE PRESIDENT ENGINEERING  
*Jamie D. Bayley*

PREPARED BY: D.C. CLARK  
 ISSUED: JULY 19, 1996  
 REVISED: SEPTEMBER 5, 2006

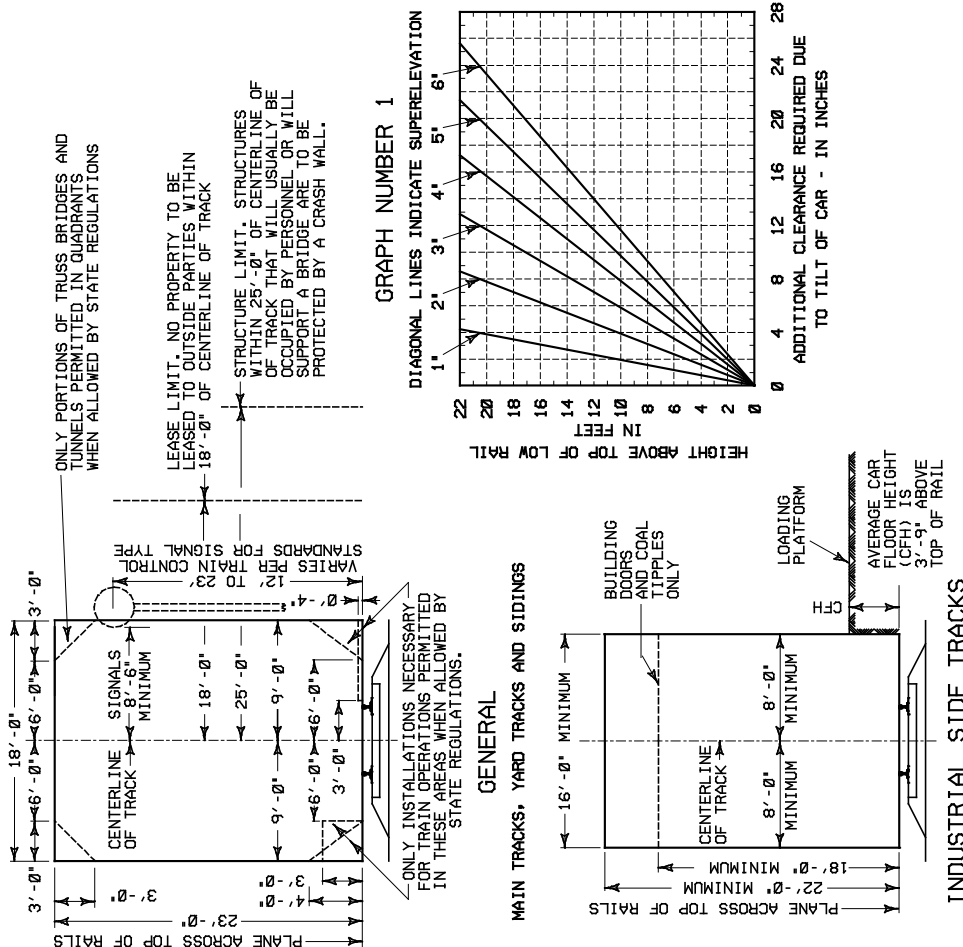

2605

**DIMENSIONS - NOTES:**  
 ARE SHOWN IN FEET AND INCHES (F-I-IN).  
 ARE FOR TANGENT TRACK. SEE CSX 2604 FOR INCREASE DUE TO CURVATURE.  
 VERTICAL CLEARANCE IS MEASURED FROM TOP OF HIGH RAIL FOR THE ENTIRE FULL HORIZONTAL WIDTH DESCRIBED BELOW.  
 HORIZONTAL CLEARANCE IS MEASURED FROM CENTERLINE OF NEAREST TRACK.  
 APPLY TO ALL NEW CONSTRUCTION, RECONSTRUCTION AND ALTERATIONS  
 ALL COLUMNS ARE MINIMUM EXCEPT COLUMNS 22, 24, 27, AND 29 WHICH ARE MAXIMUM  
 CFH = CAR FLOOR HEIGHT.  
 REFERENCE CHAPTER 28 OF AREMA MANUAL FOR RAILWAY ENGINEERING FOR ENTIRE DETAILS OF STATE LEGAL CLEARANCES

TRACK CENTERS				VERTICAL				HORIZONTAL												
1	2	3	4	5	6	7	8	9	10	11	12	13	14	15	16	17	18	19	20	21
ANY TWO MAIN TRACKS	NON-MAIN TRACKS	ADJACENT NON-MAIN TRACKS	ADJACENT TO ANY MAIN TRACK	LADDER TRACK PARALLEL TO ANY LADDER TRACK	TWO ADJACENT LADDER TRACKS	LADDER TRACKS AND CABOOSE TRACKS	TEAM TRACKS IN PAIRS	UNLOADING TRACKS AT PLATFORMS	GENERAL (UNLESS PROVIDED FOR)	THRU BRIDGES	HIGHWAY BRIDGE (SPANNING TRACKS)	TUNNELS	BUILDING DOORS	IN BUILDINGS	GENERAL (UNLESS PROVIDED FOR)	THRU BRIDGES	HIGHWAY BRIDGE (SPANNING TRACKS)	TUNNELS	BUILDING DOORS	IN BUILDINGS
15-0	14-0	20-0	20-0	19-0	14-0	13-6	13-6	20-0	23-0	23-0	23-0	23-0	18-0	22-0	9-0	9-0	25-0	9-0	8-0	8-0

**EXCEPTIONS:**  
 COLUMN 6 SHALL BE 17-0 IN MASSACHUSETTS  
 COLUMN 7 AND 8 SHALL BE 14-0 IN MICHIGAN  
 COLUMN 14 SHALL BE 21-0 IN OHIO; 22-0 IN INDIANA, WEST VIRGINIA, & CANADA; 22-6 IN CONNECTICUT, MASSACHUSETTS, & MICHIGAN  
 COLUMN 15 SHALL BE 22-6 IN CONNECTICUT, MASSACHUSETTS, & MICHIGAN; 23-0 IN DELAWARE  
 COLUMN 16 SHALL BE 12-0 IN PENNSYLVANIA  
 COLUMN 20 SHALL BE 8-6 IN MASSACHUSETTS AND MICHIGAN  
 COLUMN 21 SHALL BE 8-6 IN MICHIGAN

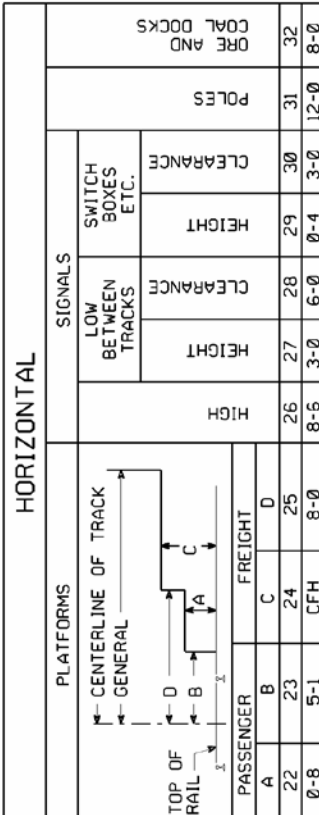

**EXCEPTIONS:**  
 COLUMN 22 SHALL BE 0-4 IN ILLINOIS  
 COLUMN 23 SHALL BE 5-2 IN CONNECTICUT  
 COLUMN 25 SHALL BE 8-6 IN CONNECTICUT, MARYLAND, MICHIGAN, NEW YORK, & PENNSYLVANIA  
 COLUMN 26 SHALL BE 9-0 IN DELAWARE; 12-0 IN PENNSYLVANIA  
 COLUMN 27 SHALL BE 4-0 IN CANADA  
 COLUMN 29 SHALL BE 0-5 IN CANADA  
 COLUMN 30 SHALL BE 3-10 IN CANADA  
 COLUMN 32 SHALL BE 8-4 1/4 IN CANADA; 8-6 IN DC. & MARYLAND



STANDARD CLEARANCE MATRIX

APPROVED - DIRECTOR  
 ENGINEERING STANDARDS

APPROVED CHIEF ENGINEER -  
 ENGINEERING SERVICES

ISSUED: JULY 19, 1996  
 REVISED: NOVEMBER 12, 2014

PREPARED BY:  
 C.S. MOALE

Diagram: Roadbed Sections (2601)

2601

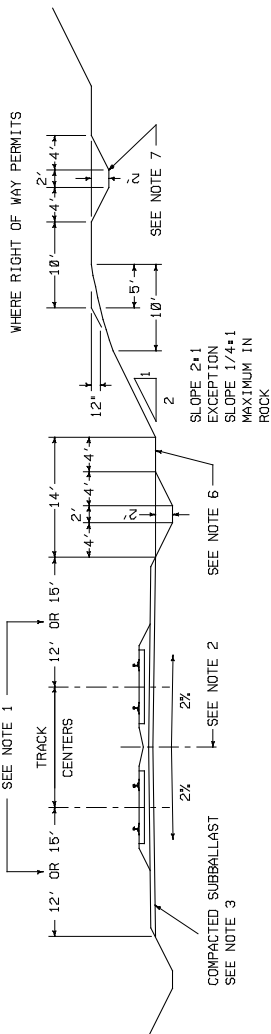

TYPICAL CUT SECTION

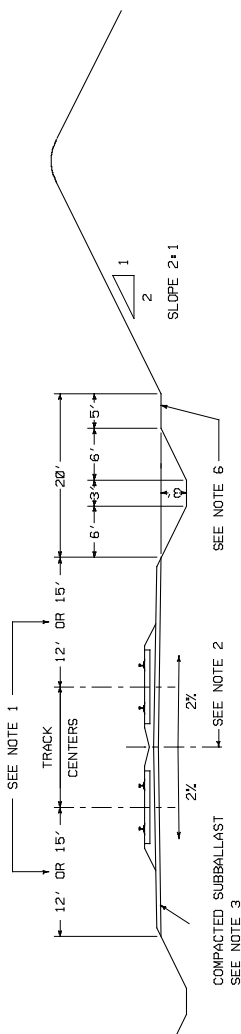

TYPICAL WET CUT SECTION

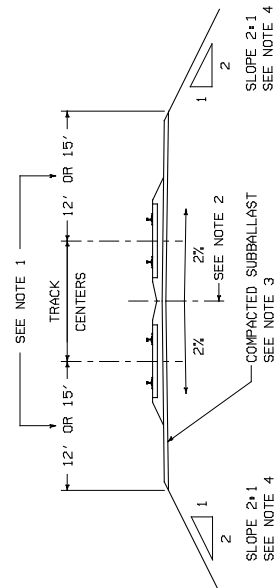

TYPICAL FILL SECTION

NOTES:

- ROADBED WIDTHS AT TOP OF SUBGRADE.
  - SINGLE MAIN TRACKS, SIDINGS, AND HEAVY TONNAGE TRACKS, 15'-0" FROM CENTERLINE OF TRACK, 30'-0" TOTAL
  - SINGLE YARD, INDUSTRY, AND OTHER TRACKS, 12'-0" FROM CENTERLINE OF TRACK, 24'-0" TOTAL
  - MULTIPLE PARALLEL TRACKS, 12'-0" OR 15'-0" FROM CENTERLINE OF TRACK DEPENDING ON THE TYPE OF TRACKS PLUS DISTANCE BETWEEN TRACK CENTERLINES.
- LOCATION OF GRADE POINT.
  - SINGLE MAIN OR OTHER TRACK IS THE CENTERLINE OF TRACK.
  - DOUBLE MAIN TRACKS IS THE CENTERLINE BETWEEN TRACKS.
  - GRADE POINT FOR MAIN TRACK AND SIDING IS CENTERLINE OF MAIN TRACK.
- DEPTH OF SUBBALLAST.
  - SUBBALLAST ON MAIN TRACKS, SIDINGS AND HEAVY TONNAGE TRACKS IS 6" OVER THE 30' ROADBED WIDTH.
  - SUBBALLAST ON YARD, INDUSTRIAL AND OTHER TRACKS IS 4" OVER THE 24' ROADBED WIDTH.
- THE STANDARD SLOPE ON FILL SECTIONS MAY BE INCREASED TO A MAXIMUM OF 1 TO 1 AT LOCATIONS WHERE THE BEARING CAPACITY OF THE NATURAL BED HAS BEEN VERIFIED BY FIELD TESTS AND THE STABILITY OF THE FILL MATERIAL VERIFIED BY LABORATORY TESTS.
- INSTRUCTIONS FOR THE USE AND INSTALLATION OF GEOTEXTILES AND GEORIGIDS ARE INCLUDED IN MWI-1003.
- OMIT BENCH WHERE EXCAVATION IS 5 FEET OR LESS.
- OMIT BERM DITCH WHEN NATURAL GROUND SLOPES AWAY FROM THE EXCAVATION.



ROADBED SECTIONS

REVIEWED - *R.P. Dean*  
 DIRECTOR,  
 STANDARDS AND TESTING

APPROVED - *A.C. [Signature]*  
 ASSISTANT VICE PRESIDENT,  
 EQUIPMENT AND TRACK  
 SYSTEMS ENGINEERING

ISSUED: JANUARY 27, 1997

REVISED: INITIAL ISSUE

Diagram: Ballast Sections (2602)

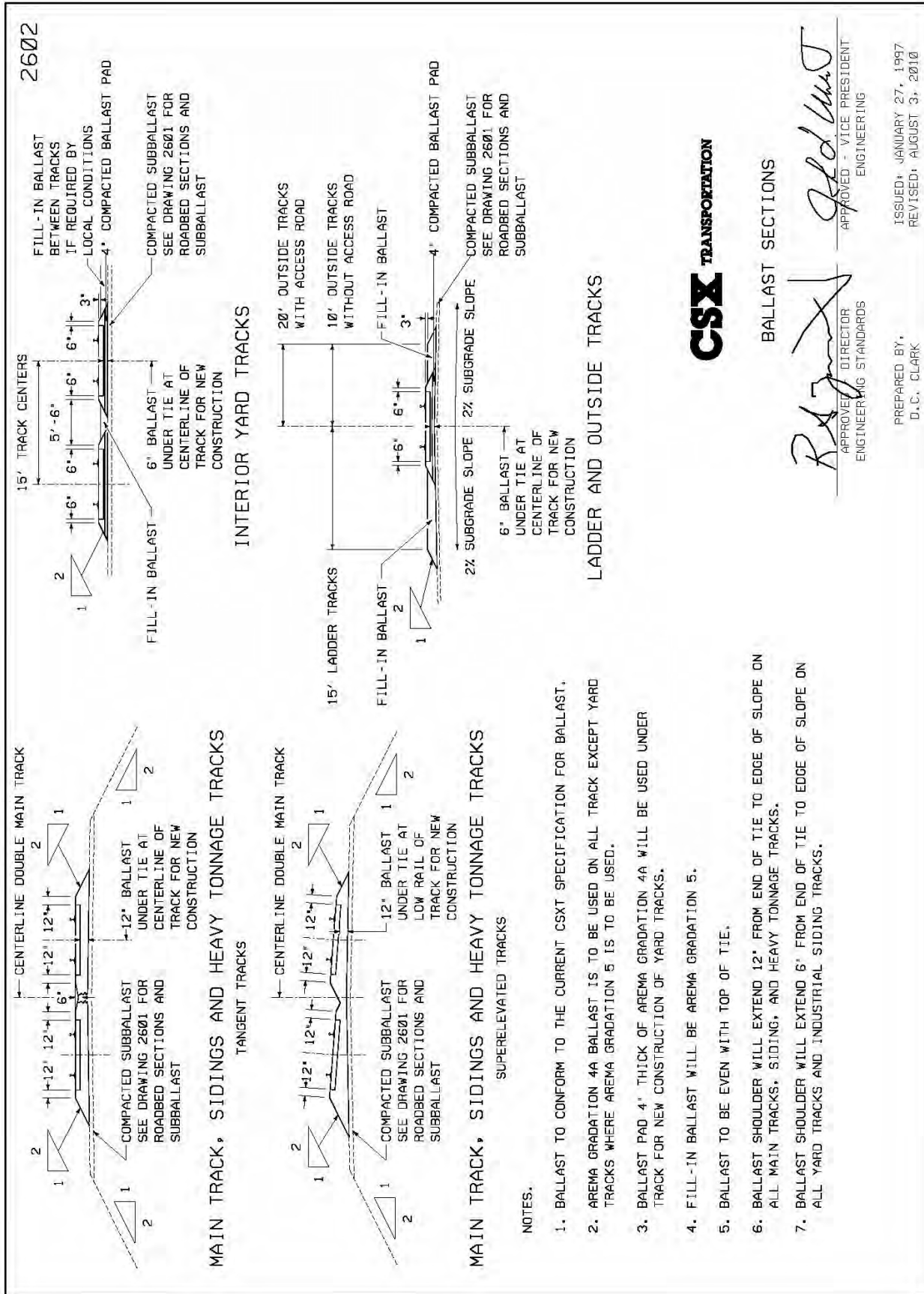
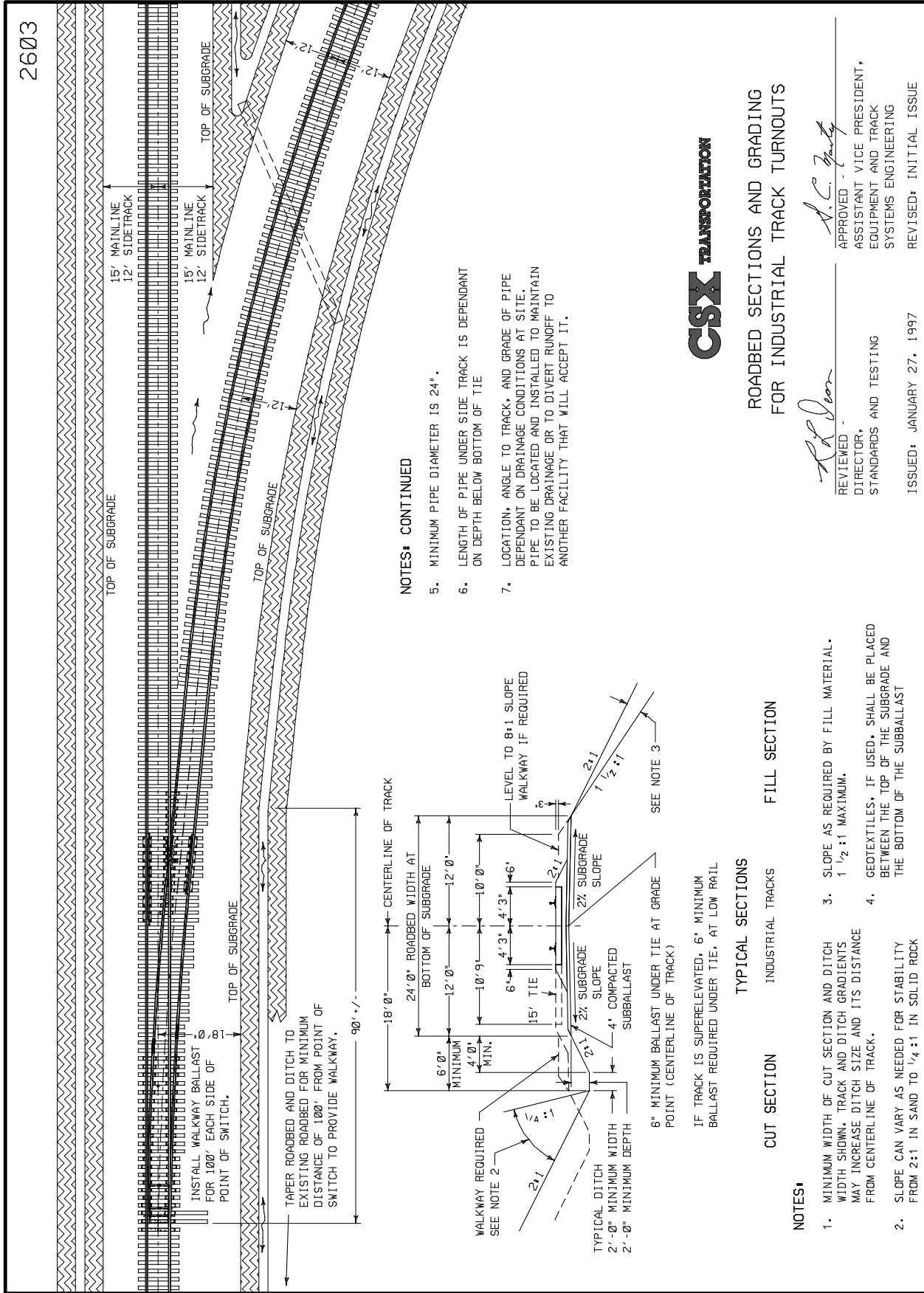

Diagram: Roadbed Sections and Grading for Industrial Track Turnouts (2603)



ROADBED SECTIONS AND GRADING  
FOR INDUSTRIAL TRACK TURNOUTS

REVIEWED - *R. J. Dean*  
DIRECTOR,  
STANDARDS AND TESTING

APPROVED - *A. C. Zaty*  
ASSISTANT VICE PRESIDENT,  
EQUIPMENT AND TRACK  
SYSTEMS ENGINEERING

ISSUED: JANUARY 27, 1997  
REVISED: INITIAL ISSUE

TYPICAL SECTIONS

CUT SECTION

INDUSTRIAL TRACKS

FILL SECTION

Diagram: Number 8 Turnout and Crossover (2220)

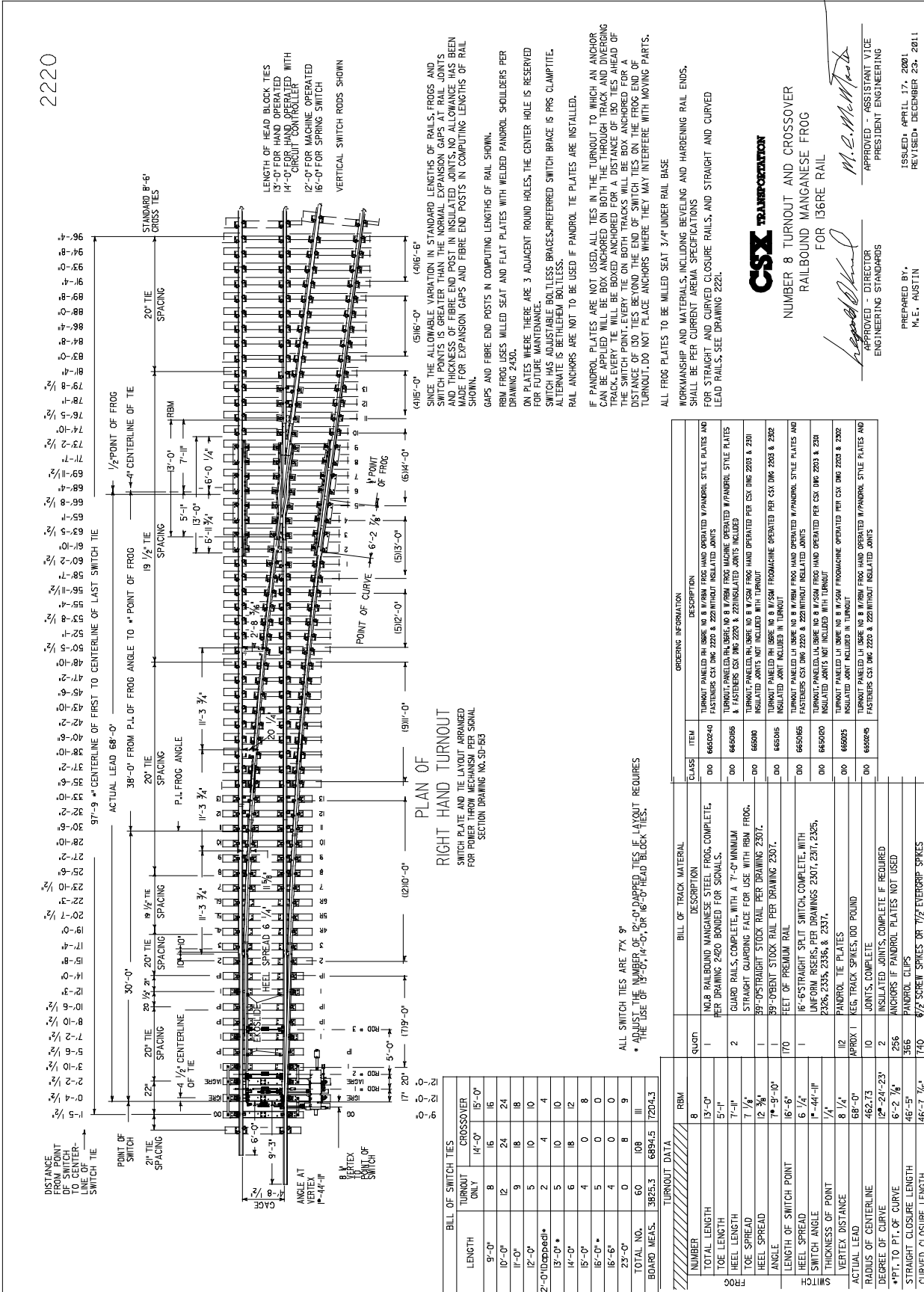

2220

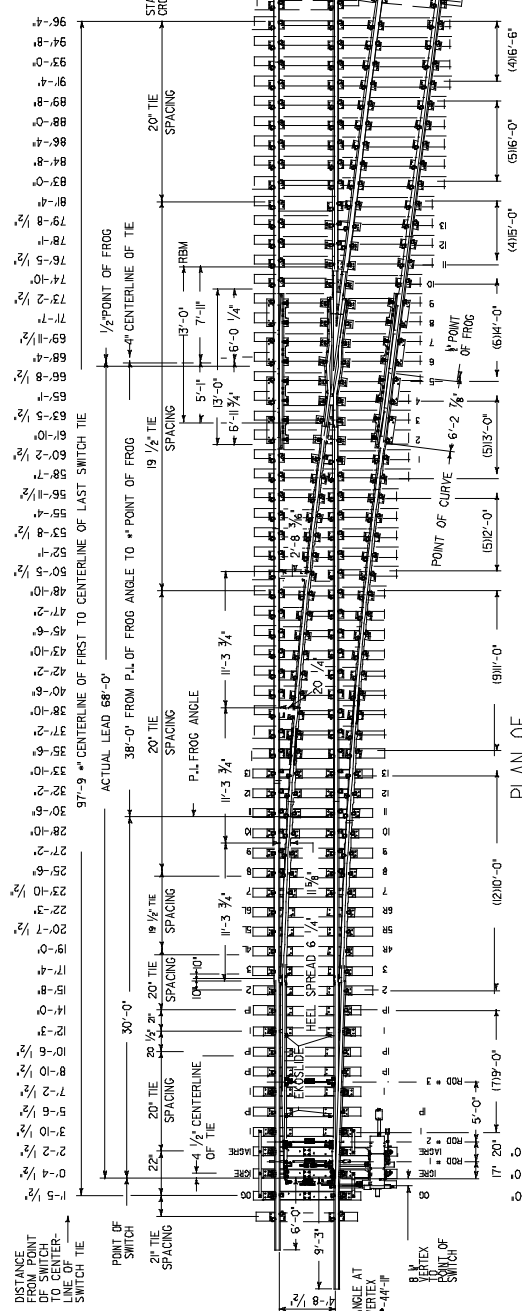

LENGTH OF HEAD BLOCK TIES  
13'-0" FOR HAND OPERATED  
14'-0" FOR HAND OPERATED WITH  
CIRCUIT CONTROLLER  
12'-0" FOR MACHINE OPERATED  
16'-0" FOR SPRING SWITCH  
VERTICAL SWITCH RODS SHOWN

SINCE THE ALLOWABLE VARIATION IN STANDARD LENGTHS OF RAILS, FROGS AND SWITCH POINTS IS GREATER THAN THE NORMAL EXPANSION GAPS AT RAIL JOINTS AND THICKNESS OF FIBRE END POST IN ISOLATED JOINTS, NO ALLOWANCE HAS BEEN MADE FOR EXPANSION GAPS AND FIBRE END POSTS IN COMPUTING LENGTHS OF RAIL SHOWN.

GAPS AND FIBRE END POSTS IN COMPUTING LENGTHS OF RAIL SHOWN.

RBM FROG USES MILLED SEAT AND FLAT PLATES WITH WELDED PANDROL SHOULDERS PER DRAWING 2439.

ON PLATES WHERE THERE ARE 3 ADJACENT ROUND HOLES, THE CENTER HOLE IS RESERVED FOR FUTURE MAINTENANCE.

SWITCH HAS ADJUSTABLE BOLTLESS BRACES, PREFERRED SWITCH BRACE IS PWS CLAMPTITE. ALTERNATE IS BETHLEHEM BOLTLESS.

RAIL ANCHORS ARE NOT TO BE USED IF PANDROL TIE PLATES ARE INSTALLED.

IF PANDROL PLATES ARE NOT USED, ALL TIES IN THE TURNOUT TO WHICH AN ANCHOR CAN BE APPLIED WILL BE BOX ANCHORED ON BOTH THE THROUGH TRACK AND DIVERGING TRACK. EVERY TIE WILL BE BOXED ANCHORED FOR A DISTANCE OF 180 TIES AHEAD OF THE SWITCH POINT. EVERY TIE ON BOTH TRACKS WILL BE BOX ANCHORED FOR A DISTANCE OF 180 TIES BEYOND THE END OF SWITCH TIES ON THE FROG END OF TURNOUT. DO NOT PLACE ANCHORS WHERE THEY MAY INTERFERE WITH MOVING PARTS.

ALL FROG PLATES TO BE MILLED SEAT 3/4" UNDER RAIL BASE

WORKMANSHIP AND MATERIALS, INCLUDING BEVELING AND HARDENING RAIL ENDS, SHALL BE PER CURRENT AREMA SPECIFICATIONS FOR STRAIGHT AND CURVED CLOSURE RAILS, AND STRAIGHT AND CURVED LEAD RAILS; SEE DRAWING 2221.

**PLAN OF RIGHT HAND TURNOUT**  
SWITCH PLATE AND TIE LAYOUT ARRANGED FOR POWER THROW MECHANISM PER SIGNAL SECTION DRAWING NO. SP-63

ALL SWITCH TIES ARE 7'X 9"  
\* ADJUST THE NUMBER OF 12'-0" DAPPED TIES IF LAYOUT REQUIRES  
THE USE OF 13'-0", 14'-0", OR 16'-0" HEAD BLOCK TIES.



NUMBER 8 TURNOUT AND CROSSOVER  
RAILROAD MANGANESE FROG  
FOR 136RE RAIL

APPROVED - DIRECTOR  
ENGINEERING STANDARDS  
*[Signature]*

APPROVED - ASSISTANT VICE  
PRESIDENT ENGINEERING  
*[Signature]*

PREPARED BY,  
M.E. JUSTIN

ISSUED - APRIL 17, 2001  
REVISED - DECEMBER 23, 2011

Diagram: Number 8 Offset and Layout (2221)

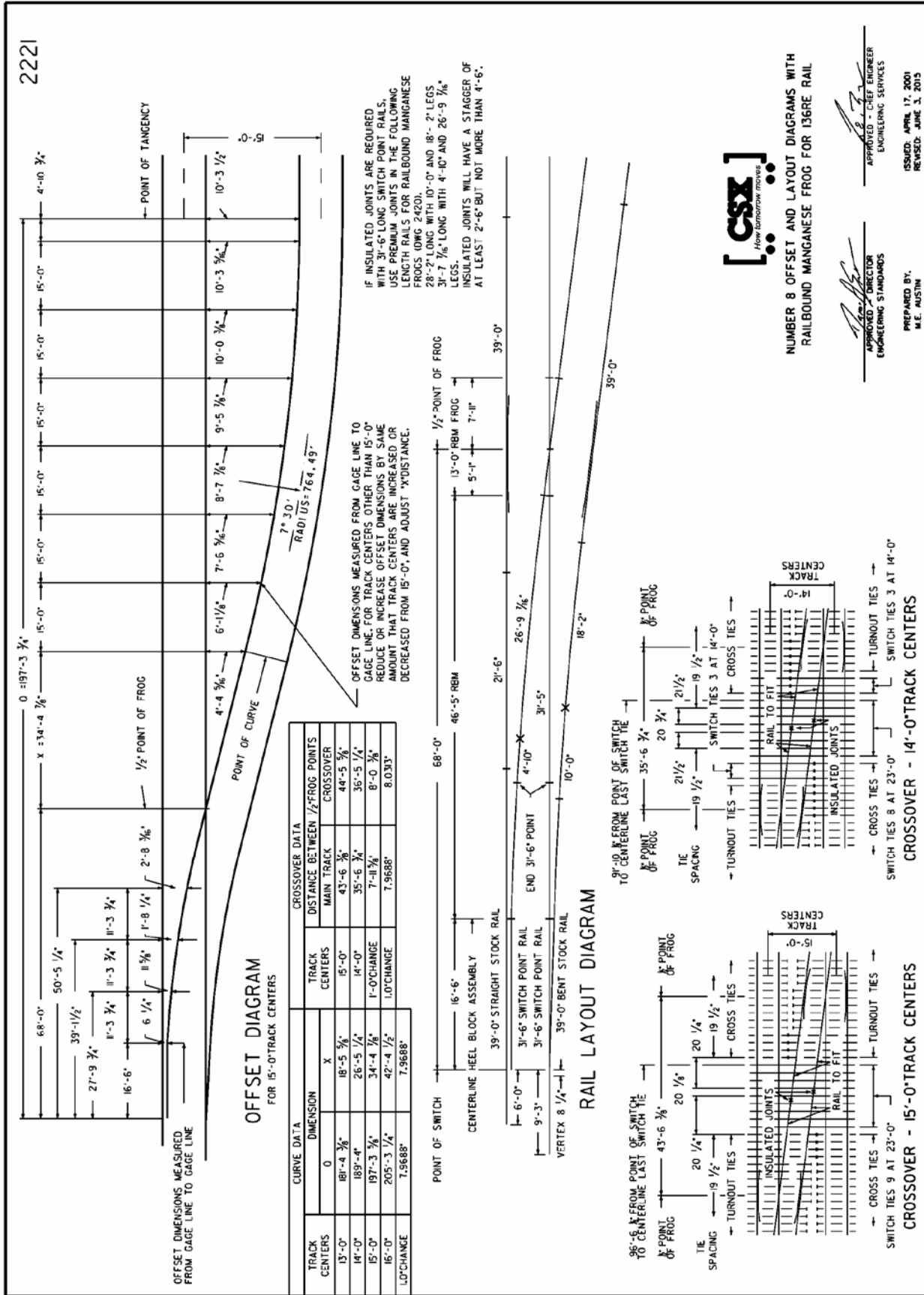
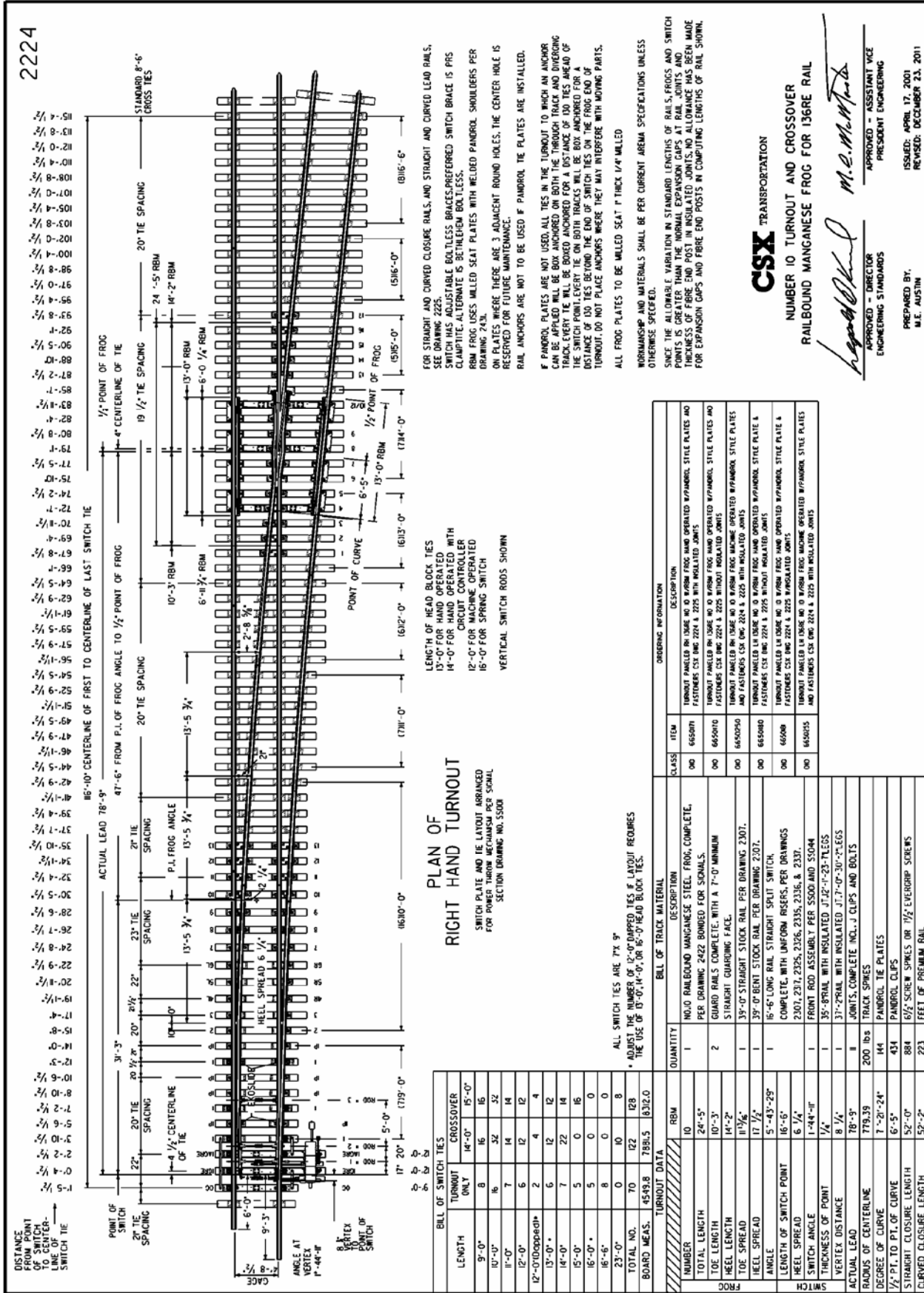



Diagram: Number 10 Turnout and Crossover (2224)



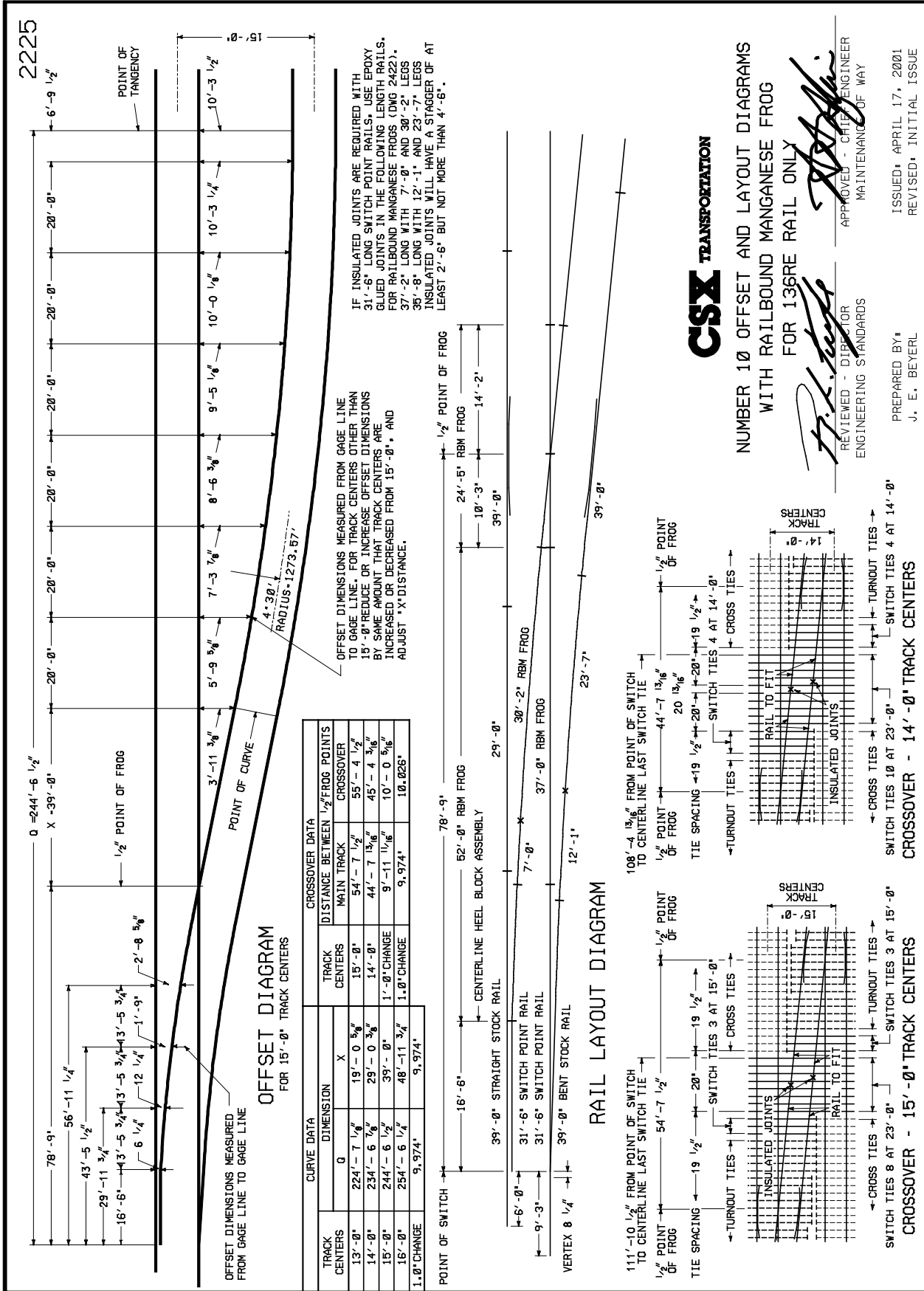



Diagram: Commercial Track A 640.6(2)

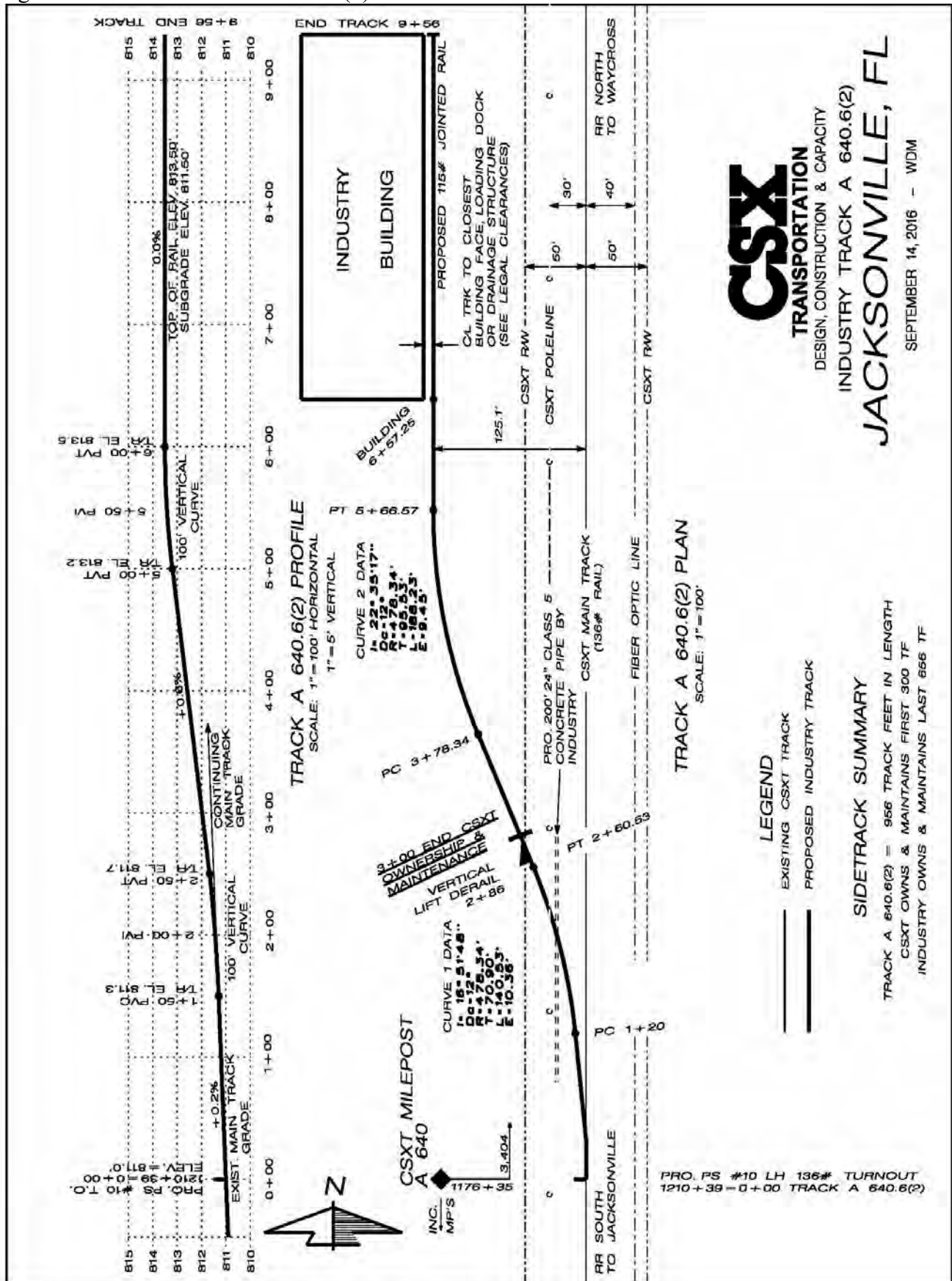
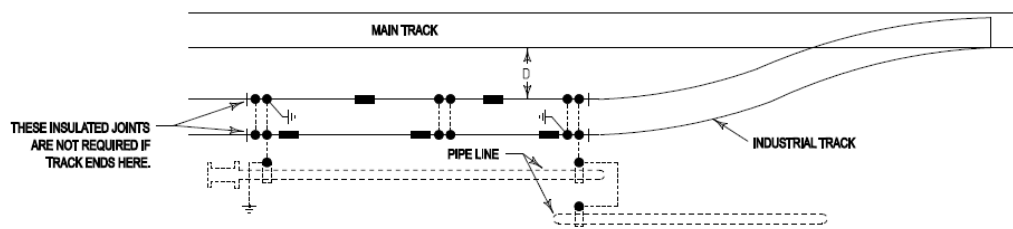
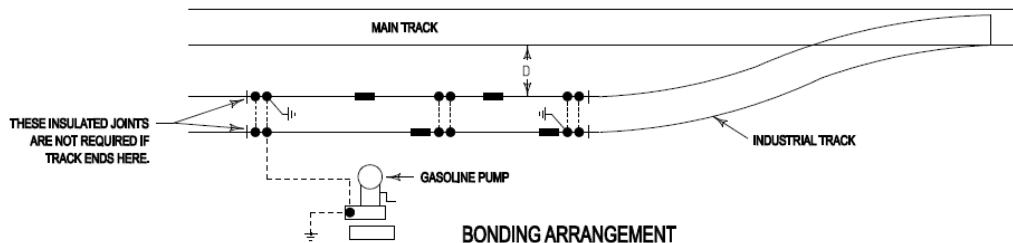

Diagram: Loading or Unloading Combustible and Flammable Liquids or Flammable Gases



**BONDING ARRANGEMENT  
FOR LOADING AND UNLOADING TRACKS**  
FIGURE A



**BONDING ARRANGEMENT  
FOR ALL FILLING STATIONS  
SERVING RAIL MOTOR COACHES AND  
INTERNAL COMBUSTION LOCOMOTIVES**  
FIGURE B

**NOTES:**

- 1 - The electrical connections shall be not less than one No. 4 nor less than two No.6 AWG stranded copper, bronze, or copper-covered steel wire.
- 2 - Grounded electrodes shown shall be connected directly to rail, pipe or other equipment to be grounded.
- 3 - Where pipe connected derail is used, pipe shall be insulated.
- 4 - Connections of copper wire to pipe line shall be permanently clamped or brazed to an exposed section of the pipe.
- 5 - The minimum for "D", the distance from near rail of main track to near rail under center of spotted car, shall be as prescribed by state laws, city ordinances, Interstate Commerce Commission regulations, and National Board of Fire Underwriters.
- 6 - Cars spotted for loading or unloading must not bridge insulated rail joints or be coupled to cars outside of the insulated track section at any time during loading or unloading operations.
- 7 - Insulated joints shall be of approved type.
- 8 - Either consignor or consignee shall provide a suitable sign for marking loading or unloading section.
- 9 - Bonding shall be done in accordance with approved practice. Rail joints are to be double bonded.
- 10 - Bonding arrangements shown are not applicable in electrified territory.
- 11 - No rail grinding, bond welding, or flint igniter operations are permitted on or near tracks once transfer equipment is in service.

**LEGEND**  
 INSULATED JOINT  
 RAIL JOINT, DOUBLE BONDED

APPROVED   
Chief Engineer Train Control



Bonding Arrangements On Track Used For Loading Or Unloading  
Combustible And Flammable Liquids Or Flammable Gases

Issued Oct 1, 1996 Revised

**SS500**  
SHEET 1 OF 1

## Construction

### A) GENERAL

No work of any type shall be performed on CSXT right of way, which could affect CSXT roadbed, or track, without written permission and evidence of proper insurance as may be required. Construction of Industry's structures, roadbed, track, etc., shall not begin prior to receiving CSXT's approval of final plans.

Industry shall obtain all necessary approvals and permits required by governmental agencies for all work on CSXT right of way, including but not limited to grading, drainage, vegetation, erosion control, and siltation prevention devices.

Track, roadbed, and structures shall be constructed to the line and grade as shown on the approved final plans. The industry shall supply the stakeout for entire project including marking of the point-of-switch in the tracks. The industry shall arrange for their track to be tied into CSXT's track at the ownership point. Industry shall be responsible for compromise and/or transitions joints or rails between CSXT's rail size and industry rail size.

Inspection of the completed track will be made by CSXT personnel, and will not be placed in service without such approval. Inspection will include grading, drainage, structures, clearances, track, walking conditions, and related appurtenances to assure satisfactory compliance with approved final plan and CSXT Standards for construction and safety. To ensure uniform curvature, industry tracks with curvature in excess of 10° shall be stringlined by the industry prior to the in service inspection by CSXT; stringline notes and/or as built data shall be provided to CSXT upon request.

### B) TIES

#### Use of Steel, Concrete, and Composite Crossties

The use of steel, concrete, and composite crossties for industry owned tracks and turnouts is permitted. Signaled territory, as well as those industrial tracks with active road crossing warning devices, may require certain sections of the track to employ insulated crossties. The use of steel, concrete, or composite ties in industrial tracks should be noted on the plans, along with the manufacturer of the product. The industry shall consult with and follow the manufacturer's guidelines for installation and maintenance of steel and concrete crossties. Industries located in high rot zones (south of middle Alabama and Georgia) should consider alternate crossties (including borate treated wood ties) for increased service life.

#### Spacing

The center-to-center spacing for wood, concrete, and composite crossties shall be 20 inches, except for ties in special trackwork such as turnouts and road crossings. In these cases, use the tie spacing shown in the standard plan. The center-to-center spacing of steel crossties shall be 24 inches.

#### Joints

Bolted joints are to be centered between ties when possible. Field welded joints are to be centered between ties. Glued insulated joints are to be centered between ties. All bolt holes in bolted joint bars are to be filled with appropriate fasteners or the joint shall be welded.

### Special Track Work

Turnouts, derails, Rail-to-rail crossings, road crossings, and special track work will have ties spaced as shown on CSXT Standard Drawings or the standard drawings associated with the turnout, derail, crossing, or special trackwork being installed.

### Bridge Approach Ties

Bridge approach ties shall be installed in accordance with CSXT Standard Drawing, page 46.

## C) SPECIAL CONSIDERATION FOR WOOD AND COMPOSITE TIES

### Lining Ties

All ties shall be placed in track at right angles to the centerline of the track. The end of the tie on the line side shall be 4'-3" from the centerline of the track. The line end of the ties shall be to the right hand side of the track, facing north or east (timetable direction) except for sidings and multiple tracks. In this case, ties in the two outside tracks are lined to the outside. Switch ties shall be lined on the straight side, except as noted on the standard plans.

### Adzing

When necessary to adze ties, an adzing machine shall be used. The adzing must be done to give the tie plate a full bearing across the tie and parallel with the plane of track.

### Damaged Ties

When handling or spacing ties, care shall be taken to prevent damage with picks and hammers. Pulling ties into position with picks will not be permitted; tie tongs shall be used for this purpose.

### Use of Tie Plugging Compound and Plugs

The pulling of spikes, once driven, shall be avoided as much as possible. When spikes are pulled, the holes shall be immediately plugged with a chemical tie-plugging compound that completely fills the spike holes and allows for the proper drive of spikes that are subsequently added to the crosstie. Alternatively tie plugs may be used to fill the spike hole

### Applying Tie Plates

Double shoulder tie plates shall be used on all ties. Care must be taken that canted tie plates incline toward the center of track and that plates having a different amount of cant or flat plates are not intermixed. Before placing tie plates on the tie, dirt and other substances shall be removed from the bottom of the tie plate and top of the tie.

## D) GAGE RODS

The use of gage rods for new track construction is prohibited.

E) LAYING JOINTED RAIL

Rail Placement

Rails shall be so placed that the joints in each line of rail shall be within the middle half of the opposite length rail. To minimize the cutting of full-length rails, short rails may be used in adjusting for proper spacing of joints, but no rail less than thirty three feet (33') on curves or nineteen feet six inches (19'-6") on tangents shall be used.

Cutting of Rail

Flame cutting of rail will not be permitted. Rail shall be cut with a rail saw. Bolt holes shall be drilled, not torch cut.

Cleaning

The bottom of the rail and bearing surfaces of the crosstie and tie plates shall be cleaned before rail is laid.

Rail Temperature

A rail thermometer will be used in determining rail temperatures at the time of installation. Approved thermometers include dial rail thermometer and electronic surface thermometers. Temperatures will be read and recorded periodically during the day and supervisory employee shall see that it is checked frequently and that proper expansion shims are used. When taking rail temperatures, the thermometer will be placed on the web of the rail on the side away from the sun. Non-contact thermometers shall be located no more than two feet away and pointed directly at the web of the rail on the side away from the sun. A record of rail laying temperatures and expansion are to be made available for inspection by CSXT upon request.

Expansion Shims

Rail expansion shims of approved thickness and material will be used per 39-foot rail in accordance with the following temperature table:

**Table 3: Expansion Required for Jointed Rail**

Below 6°F	5/16" in each joint
6 – 25°F	1/4" in each joint
26 – 45°F	3/16" in each joint
46 – 65°F	1/8" in each joint
66 – 85°F	1/16" in each joint
Over 85°F	no shims necessary

Laying Rail

Except as otherwise specified, rails shall be laid one at a time, and to ensure good adjustment, the rail ends brought squarely together against suitable rail expansion shims and bolted before spiking.



Panel Track

At locations approved by CSXT, track may be laid by the panel method. Joints must be staggered after the panels are in place. After staggering, the joints shall be located as nearly as possible to the middle of the opposite rail.

Gage

The gage of track is the distance between the heads of rails, measured at right angles thereto, at a point five-eighths (5/8") inch below the top of rail. Standard gage is 4'-8 1/2". No change in gage on account of curvature will be permitted without the express permission of CSXT. **Gaging must be done at the time the rail is laid using a gage manufactured for such purpose.**

Butting Used Rail with New Rail

When butting used rail with new rail, welding shall be used to build up the end of used rail to match the new rail. This provides a smooth transition over the joint. The same process shall be used when it is necessary to butt used rail to new frogs, switches, etc.

Anchors

Rail anchors for jointed track shall be applied at sixteen (16) anchors per 39 feet rail length, box anchoring eight ties spaced in accordance with CSXT Rail Anchoring Policy, MWI 703 (excerpt shown below). Box anchoring is defined as: an anchor on each side of a tie, on both rails, or four (4) anchors applied to one tie. Anchors shall be securely and squarely fastened to rail and have a solid bearing against the ties.

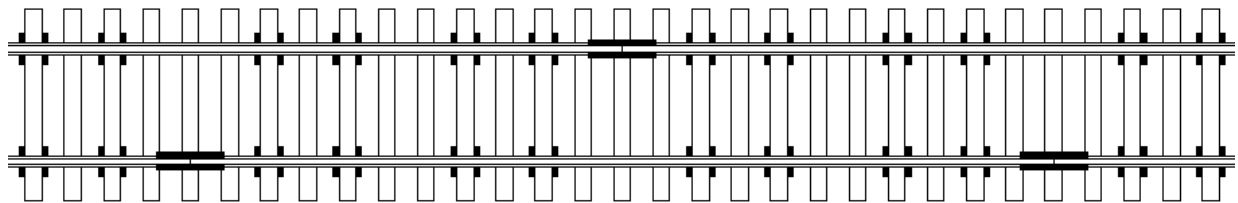

JOINTED RAIL - 16 ANCHORS PER 39 FOOT RAIL, BOX ANCHOR 8 TIES.

RAIL ANCHOR PATTERNS

F) LAYING WELDED RAIL

Track locations that will have over 400 feet in length of welded rail are considered to be continuous welded rail track and shall meet all the requirements for continuous welded rail track (Reference 49 CFR 213.121(f)).

Installation of Continuous Welded Rail will be governed by CSXT Continuous Welded Rail Policy, MWI 1125, latest revision, available upon written request. Field welds will be governed by CSXT Welder's Manual, MWI 801, latest revision, available upon written request. Rail anchors for welded rail will be governed by CSXT Rail Anchoring Policy, MWI 703, latest revision, available upon written request.

G) SPIKING

Spiking patterns will be governed by CSXT Standard Drawings, pages 36 through 40.

H) SUPERELEVATION & SPIRALS

See CSXT Superelevation of Curves, MWI 1104, latest revision, available upon written request.

I) SURFACING & LINING TRACK

Following the assembly of the track, sufficient ballast shall be unloaded in the tie cribs and shoulders of the track structure to restrain movement or buckling of track due to temperature changes. Such ballast unloading shall provide an adequate amount of ballast for the initial track raise with sufficient surplus to continue to hold the track after the raise. On spirals and curves, the outside rail shall be superelevated as indicated on CSXT Standard Drawings.

Ballasting

The ballasting of track shall be accomplished in not less than two lifts. Each lift shall not exceed four inches in height, except the final lift shall be approximately two inches in height.

Surfacing

Track surfacing shall be done by methods that will prevent undue bending of the rail or straining of the joints. The amount of track lift shall not endanger the horizontal or vertical stability of the track. The track shall be initially raised so that a final raise of not less than one inch nor more than three inches will be required to bring it to finished surface. All ties that pulled loose shall be replaced to proper position, shall have full bearing against the rail, and be properly secured to the rail.

Tamping

Tamping of ballast shall be done with power tamping equipment. Control or cycling of the power tamper shall provide the maximum proper compaction of the ballast uniformly along the track. The ballast shall be thoroughly tamped on both sides of the tie from a point 15 inches inside the rails to the ends of the ties.

Lining

The track shall be placed in proper alignment when initially raised and tamped. The final alignment of track shall be done by a power operated lining machine capable of meeting the specified track tolerances.

Final Raise and Surfacing

When the track has been raised to within two inches of the final grade and properly compacted, a finishing lift shall be made by jacking the track to the finished top-of-rail elevations. The ballast shall then be applied under the ties for their entire length and thoroughly driven in place for a space extending from fifteen inches inside either rail to the ends of the ties, by tamping machines, tamping picks, or tamping bars. The ballast under the remainder of the tie bearing shall not be tamped. In making the finishing lift, the spot board and track level board shall be used with care and the track brought to a true surface with the required superelevation of the outer rail on spirals and curves.

Final Lining

After the track has been brought to the established track center, every effort shall be made to maintain appropriate line during preliminary ballast applications.

### Final Dressing of Ballast

The Contractor shall provide the necessary templates for shaping the ballast sections. The edge of ballast shall be brought to true line by means of shovels, forks, or ballast regulating machines. The ballast shoulders shall be uniformly formed and compacted. All excess ballast shall be removed and deficiencies of ballast shall be supplied.

### J) GRADE CROSSING

#### Installation

Any road crossing to be constructed over the track at grade shall be installed in accordance with CSXT MWI 901 or by a crossing surface approved by the State in which the track is located. Any road crossing over CSXT owned track shall be CSXT's standard surface and be installed by CSXT track forces.

#### Rail Joints

No joints will be permitted within the confines of the crossing, including road shoulders.

#### Completion

Highway and street crossings shall be completed in their entirety, including grading, planking, and/or paving in exact accordance with the plans and specifications. Care shall be taken to ensure the least possible interference with highway or street traffic.

### K) FINAL CLEANING

All refuse from construction operations shall be removed and disposed of and the entire roadbed and right-of-way shall be left in a presentable condition.

### L) DERAILS AND BUMPING POSTS

Derails and bumping posts are to be installed as per CSXT approved plans provided by Industry or its Consultant.

### M) GATES AND FENCES

Gates may only be installed on tracks that are located on the industry's property. The gate shall have adequate devices to secure the gate open while CSXT crews are operating on the track. In addition, gates installed across industry sidetrack must be capable of being secured with two locks—one supplied by the industry and one supplied by the CSXT for its use when switching the industry. Fences and gate openings shall be located in compliance with the minimum clearance requirements. CSXT recommends the Industry consider double posting gates.

N) INSPECTION

After completion of the work, a final inspection will be made. Any previous inspection or acceptance will not preclude rejection at the final inspection of anything that is not satisfactory or not in accordance with the Guidelines.

A quarterly inspection of the sidetrack will be made by local CSXT Maintenance Personnel to determine any repairs that might be needed. If the track has been inactive for an extended period of time, an inspection must be made by CSXT before any cars may be spotted on the track.

O) MAINTENANCE

All completed work shall be maintained and kept in finished condition by the Contractor until final inspection and acceptance. **After the track is placed in service, the Industry shall maintain its portion of the track in a condition at minimum in compliance with FRA Class I track (reference 49 CFR 213).** Failure to maintain track in a proper manner may lead to suspension of service until the defective condition(s) are corrected.

Diagram: Main Track Spiking Patterns Side Track Spiking Patterns (2512)

2512

MAIN TRACK - A TRACK, OTHER THAN AN AUXILIARY TRACK, EXTENDING THROUGH YARDS AND BETWEEN STATIONS, UPON WHICH TRAINS ARE OPERATED IN CONFORMANCE WITH RULES OR SPECIAL INSTRUCTIONS.

SIDING - AN AUXILIARY TRACK DESIGNATED IN SPECIAL INSTRUCTIONS FOR THE MEETING OR PASSING OF TRAINS.

SIDE TRACK - AN AUXILIARY TRACK FOR PURPOSES OTHER THAN MEETING OR PASSING TRAINS.

THE SPIKING PATTERN ON CURVES WILL BEGIN AT THE TANGENT TO SPIRAL MARKER PLATE AND END AT SPIRAL TO TANGENT MARKER PLATE.

THE SPIKING PATTERN ON COMPOUND CURVES WILL BE BASED ON THE HIGHEST DEGREE OF CURVATURE IN THE CURVE AND WILL BE USED FOR THE ENTIRE CURVE.

SIX AXLE LOCOMOTIVES WITH CONVENTIONAL TRACKS ARE RESTRICTED FROM OPERATING ON CURVES OVER 17'-00".

SIX AXLE LOCOMOTIVES WITH RADIAL STEERING TRUCKS ARE RESTRICTED FROM OPERATING ON CURVES OVER 23'-00".

THREE SPIKES PATTERN B AS MINIMUM WILL BE USED ON ALL TRACKS USING DISTRIBUTED OR PUSHER LOCOMOTIVES

IF A TIE PLATE DOES NOT HAVE TWO GAGE SIDE RAIL SPIKES, USE ADDITIONAL SPIKES AS SHOWN IN PATTERN C & D

TRACK ALIGNMENT		SPIKING REQUIREMENTS									
		MAIN TRACKS AND SIDINGS					SIDE/INDUSTRIAL TRACK				
DEGREE FROM	DEGREE TO	MAXIMUM AUTHORIZED FREIGHT SPEED AND TONNAGE					MAXIMUM SPEED & TONNAGE				
		UP TO 45 MPH	>25 MPH & 10 MGT	46 MPH TO 60 MPH	61 MPH AND HIGHER	UP TO 25 MPH	>25 MPH & 10 MGT	SPIKES PER TIE PLATE	SPIKING PATTERN	SPIKES PER TIE PLATE	SPIKING PATTERN
TANGENT		2	3	3	4	4	C	2	A	3	B
0°-01'	1°-59'	3	3	B	4	C	C	2	A	3	B
2°-00'	3°-59'	4	4	C	4	C	C	3	B	3	B
4°-00'	5°-59'	4	4	C	4	C	C	4	C	4	C
6°-00'	11°-59'	5	5	D	5	D	D	4	C	4	C
12°-00'	12°-59'	5	5	D	5	D	D	4	C	4	C
13°-00'	AND UP	5	5	D	5	D	D	5	D	5	D

SPIKING PATTERN "A"



SPIKING PATTERN "C"



SPIKING PATTERN "B"



SPIKING PATTERN "D"



■ = TRACK SPIKE

⊙ = TIE PLATE SCREW

POSITIVE RESTRAINT RAIL FASTENERS  
ALL TRACK ALIGNMENTS



PANDROL ROLLED PLATE



PANDROL VICTOR PLATE

MAIN TRACK SPIKING PATTERNS  
SIDE TRACK SPIKING PATTERNS

*J. E. Beyerl*

J. E. BEYERL FOR  
APPROVED - DIRECTOR  
ENGINEERING STANDARDS

APPROVED - VICE PRESIDENT  
ENGINEERING

PREPARED BY:  
M. E. AUSTIN

ISSUED: DECEMBER 27, 1996  
REVISED: DECEMBER 20, 2010

Diagram: Turnout Spiking Patterns with Bethlehem 811 Style Braces (2513) [sheet 1]

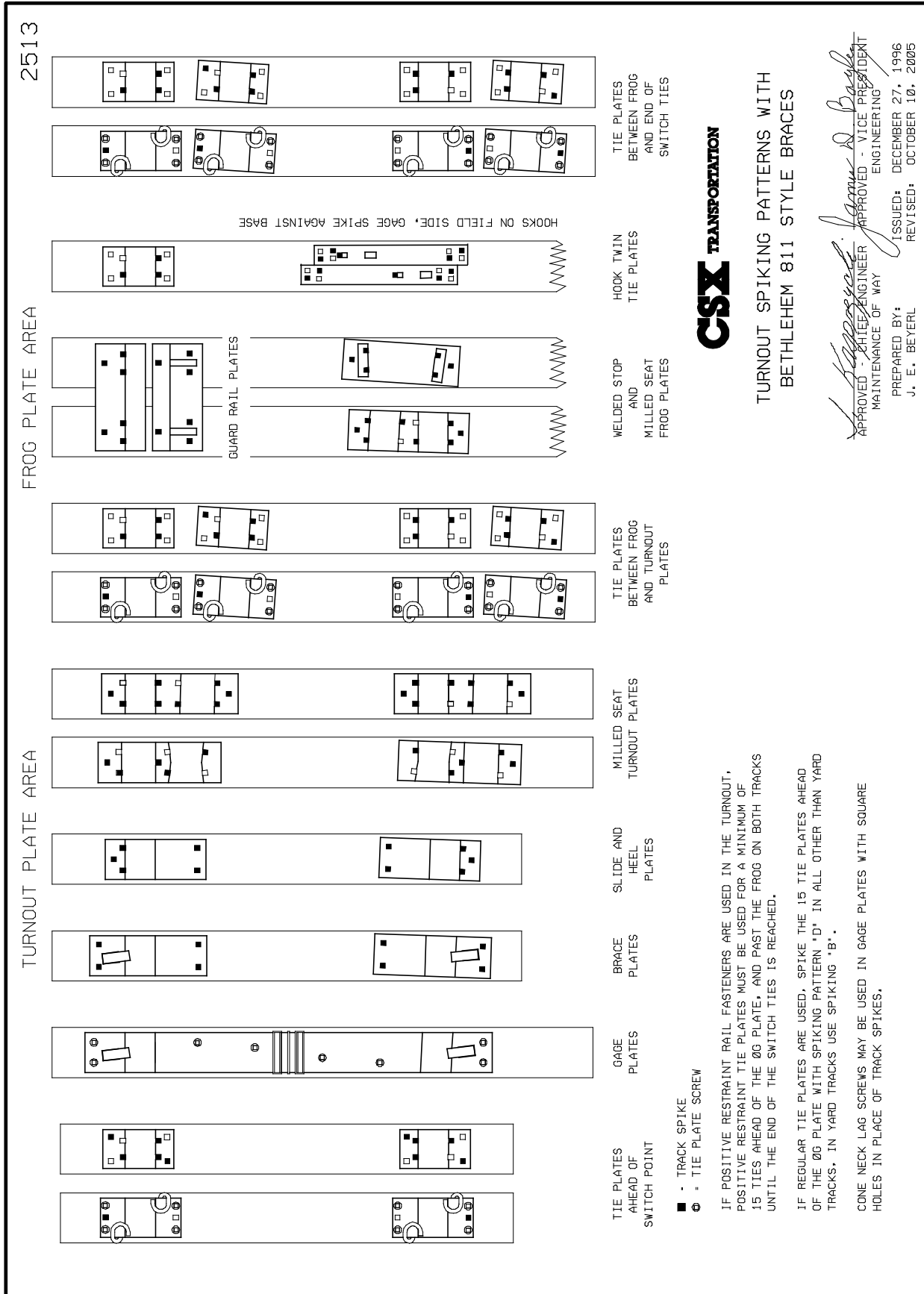

Diagram: Turnout Spiking Patterns with Bethlehem Boltless Style Braces (2513) [sheet 2]

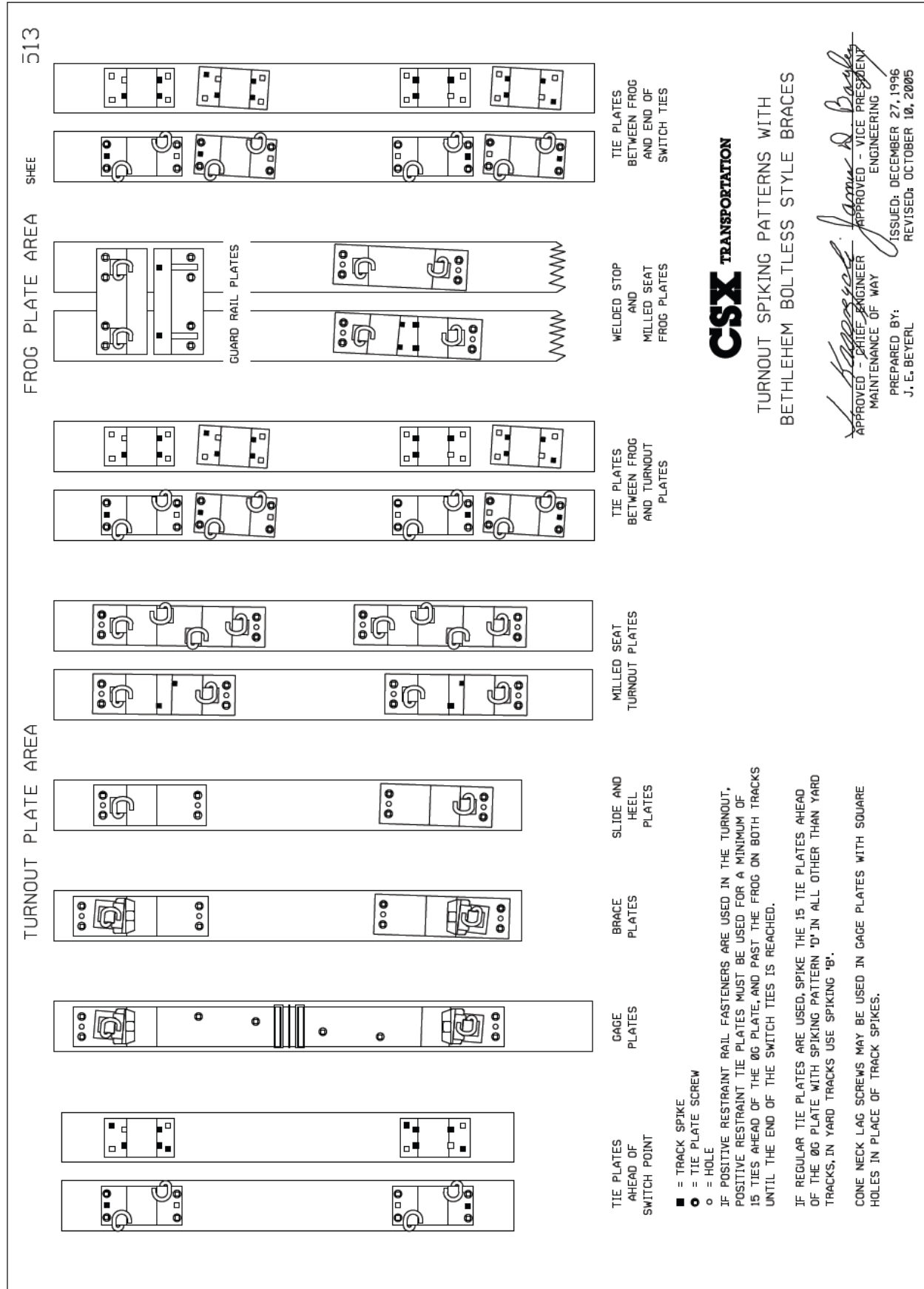

Diagram: Turnout Spiking Patterns with Clamptite Style Braces (2513) [sheet 3]

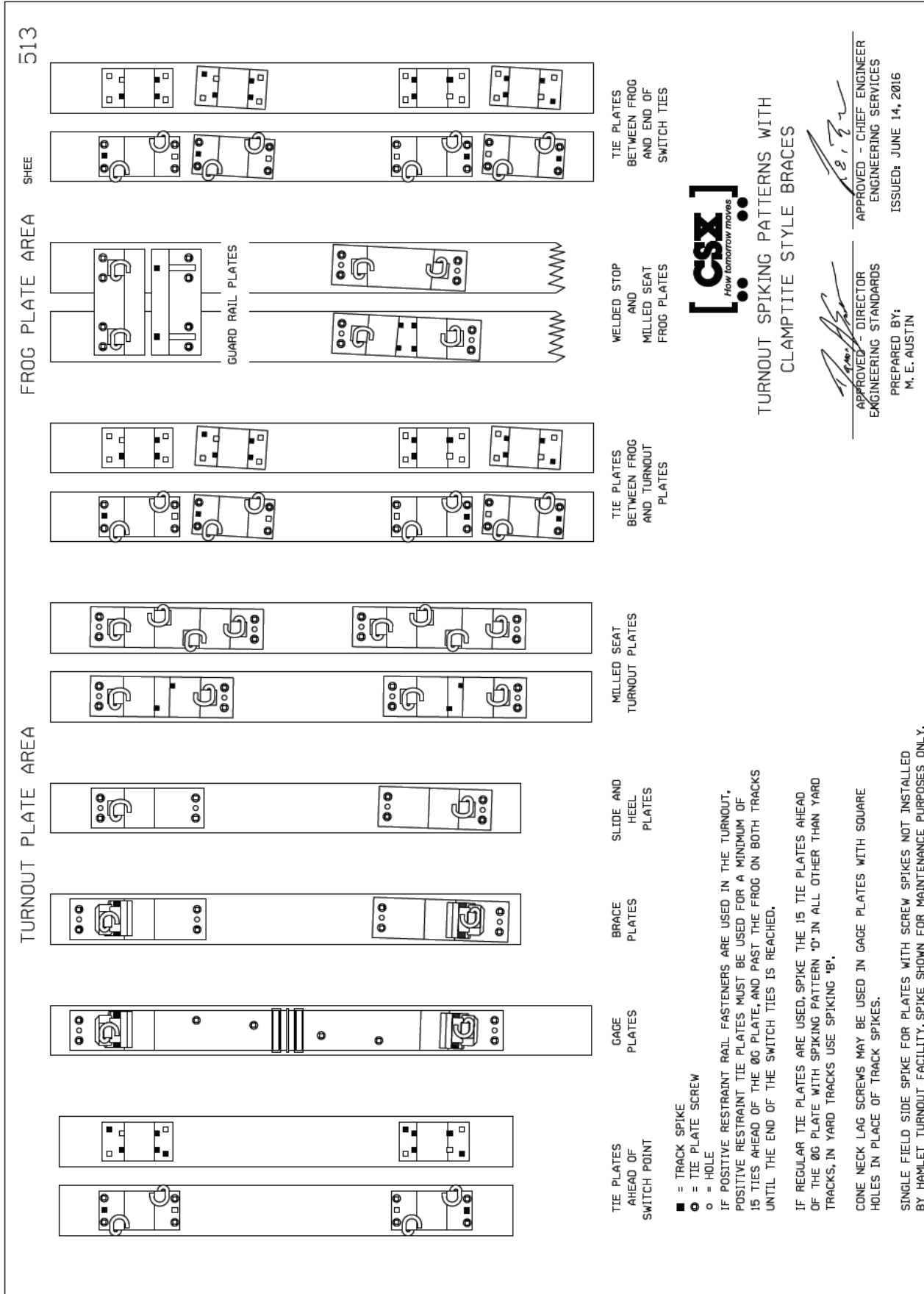
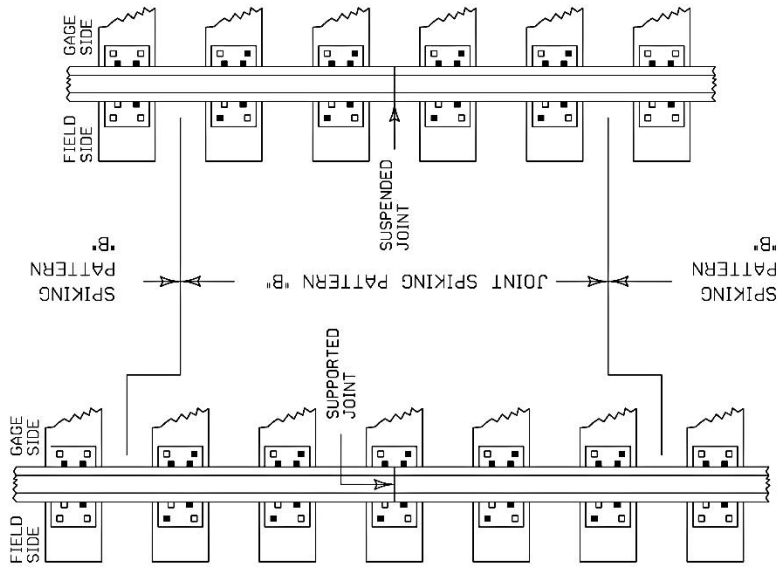

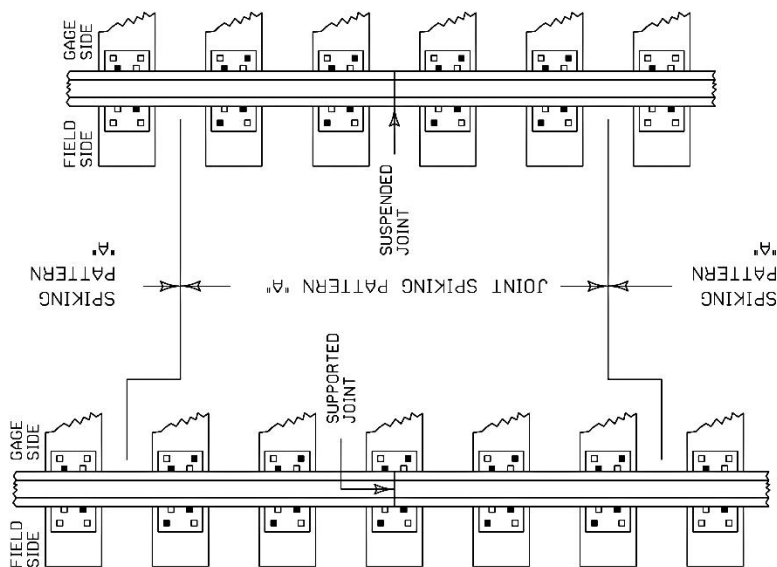

Diagram: Joint Area Spiking Patterns (2514)

2514



JOINT SPIKING PATTERN "B"



JOINT SPIKING PATTERN "A"



JOINT AREA SPIKING PATTERNS

■ = TRACK SPIKE

JOINT SPIKING PATTERN "A" USED WITH SPIKING PATTERN "A".

JOINT SPIKING PATTERN "B" USED WITH SPIKING PATTERNS "B", "C" AND "D".

SEE DRAWING 2512 FOR SPIKING PATTERNS WHEN POSITIVE RESTRAINT RAIL FASTENERS ARE USED.

APPROVED - DIRECTOR  
ENGINEERING STANDARDS

APPROVED - CHIEF ENGINEER  
ENGINEERING SERVICES

PREPARED BY:  
M. E. AUSTIN

ISSUED: DECEMBER 27 3, 1996  
REVISED: JUNE 3, 2016

Diagram: Light Duty Road Crossing--Bituminous Concrete with Rubber Panels (2521)

2521

NOTES

1. MWI 901 (LASTEST REVISION) IS TO BE USED IN CONJUNCTION WITH THIS DRAWING.
2. FOR NEW CONSTRUCTION, HIGHWAY SHOULD INTERSECT RAILROAD AT OR NEARLY RIGHT ANGLES.
3. FOR NEW CONSTRUCTION, HIGHWAY SURFACE SHOULD NOT BE MORE THAN 3" HIGHER OR LOWER THAN TOP OF THE NEAR RAIL 30' FROM THE RAIL ALONG THE ROAD CENTERLINE, UNLESS TRACK SUPERELEVATION DICTATES OTHERWISE.
4. USE STATE D.O.T. SPECIFICATIONS FOR BITUMINOUS CONCRETE AND ASPHALT SPRAY TACK COAT FOR THE STATE IN WHICH THE CROSSING IS LOCATED.
5. CROSSINGS SHOULD BE CONTINUOUS BETWEEN ROADWAY OR SIDEWALK EDGES, IF NOT PRACTICABLE, ADEQUATE DRAINAGE MUST BE PROVIDED BETWEEN CROSSING AREAS TO ELIMINATE WATER POCKETS.
6. USE TWO CLAMPS PER CRIB OR FOUR (4) RUBBER INTERFACE HOLDING SPIKES PER TIE.
7. SLOPE PAVING TO RETURN TO ORIGINAL PAVEMENT SURFACE. LENGTH OF TRANSITION WILL DEPEND ON LOCAL CONDITIONS. USE A RUNOFF OF 1 IN. PER 10 FT. WHERE PRACTICABLE.
8. IF ROADBED STABILIZATION IS REQUIRED, EXTEND IT 10 FT. BEYOND EDGE OF CROSSING UNDER TRACK.
9. PERFORATED PIPE TO BE INSTALLED WHERE OUTFALL IS PERMITTED TO PROVIDE POSITIVE DRAINAGE FROM TRACK STRUCTURE AND SUBGRADE. USE MIN. 4" DIA. PIPE AND LOCATE AT LEAST 12' BEYOND THE END OF TIE.

ORDERING INFORMATION	
ITEM NO.	RAIL WGT.
014 5250135	90-100
014 5250140	115
014 5250142	122
014 5250145	132
014 5250147	136
014 5250160	140
014 5250170	141
014 5250260	90-141



NORMAL AND LIGHT DUTY ROAD CROSSING  
ASPHALT AND RUBBER INTERFACE ON WOOD TIES

APPROVED: DIRECTOR  
ENGINEERING STANDARDS

APPROVED: CHIEF ENGINEER  
ENGINEERING SERVICES

ISSUED: MAY 27, 1997  
REVISED: APRIL 7, 2016

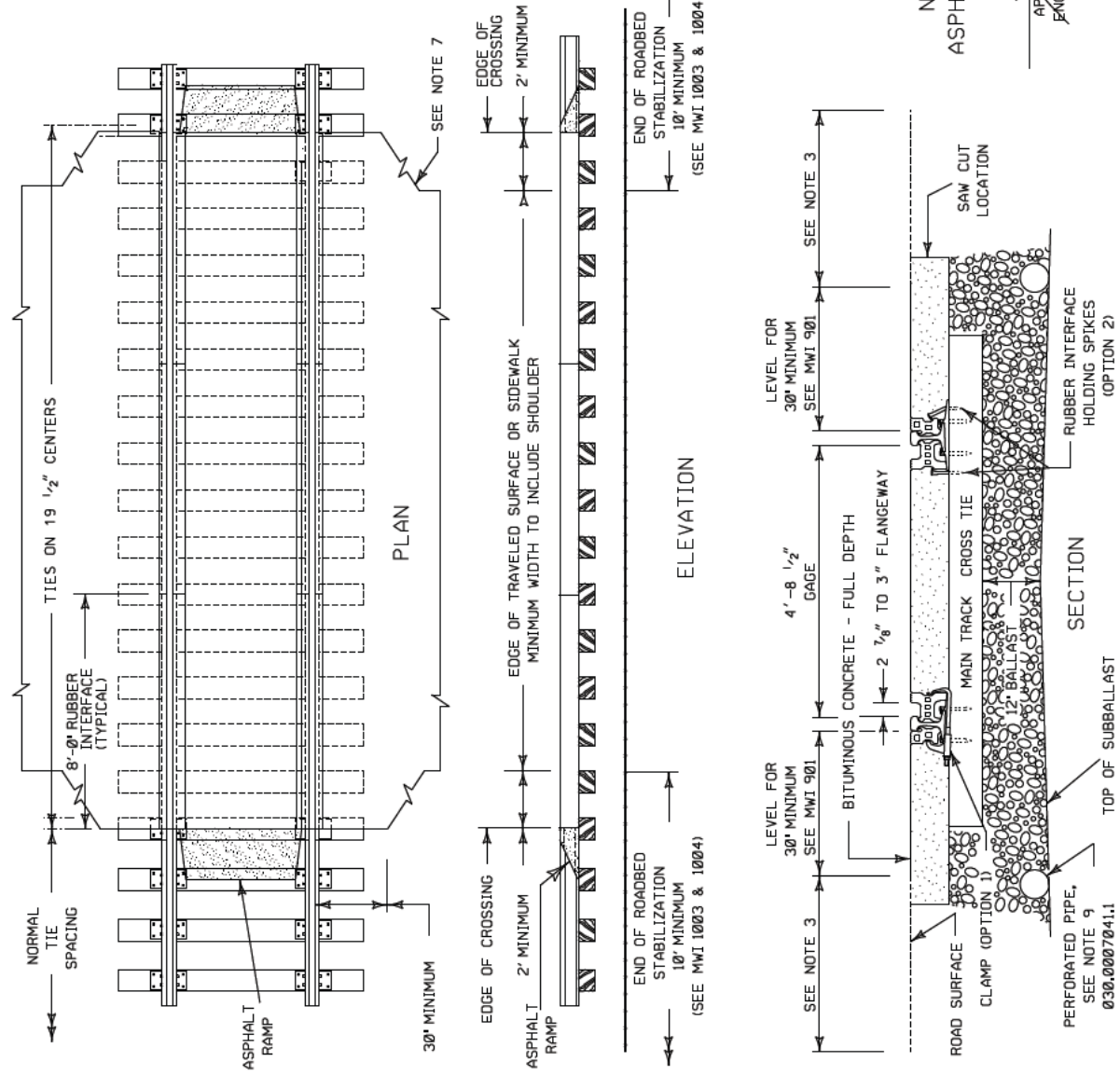

2535  
SHEET 1

NOTES

1. MWI 901 (LASTEST REVISION) IS TO BE USED IN CONJUNCTION WITH THIS DRAWING.
2. FOR NEW CONSTRUCTION, HIGHWAY SHOULD INTERSECT RAILROAD AT OR NEARLY RIGHT ANGLES.
3. FOR NEW CONSTRUCTION, HIGHWAY SURFACE SHOULD NOT BE HIGHER THAN 3" HIGHER OR LOWER THAN THE ROAD CENTERLINE, UNLESS TRACK SUPERELEVATION DICTATES OTHERWISE.
4. USE STATE D.O.T. SPECIFICATIONS FOR BITUMINOUS CONCRETE AND ASPHALT SPRAY TACK COAT FOR THE STATE IN WHICH THE CROSSING IS LOCATED.
5. CROSSINGS SHOULD BE CONTINUOUS BETWEEN ROADWAY OR SIDEWALK SHOULD, IF NOT PRACTICABLE, ADEQUATE DRAINAGE MUST BE PROVIDED BETWEEN CROSSING AREAS TO ELIMINATE WATER POCKETS.
6. SLOPE PAVING TO RETURN TO ORIGINAL PAYMENT SURFACE. LENGTH OF TRANSITION WILL DEPEND ON LOCAL CONDITIONS. USE A RUNOFF OF 1 IN. PER 10 FT., WHERE PRACTICABLE.
7. IF ROADBED STABILIZATION IS REQUIRED, EXTEND IT 10' FT. BEYOND EDGE OF CROSSING UNDER TRACK.
8. DRILL CROSSING TIMBERS OVER EACH TIE FOR TIMBER SCREW 1 1/8" DIA. WITH 2 1/2" DIA. x 1' COUNTERSINK.
9. PERFORATED PIPE TO BE INSTALLED WHERE OUTFALL IS PERMITTED TO PROVIDE POSITIVE DRAINAGE FROM TRACK STRUCTURE AND SURGRADE. USE MIN. 4" DIA. PIPE AND LOCATE AT LEAST 12" BEYOND THE END OF TIE.

ITEM NO.	RAIL WGT.	DESCRIPTION
014 5250140	115	CROSSING RUBBER INTERFACE, ORDER BY TRACK FEET.
014 5250142	122	IN 8 FT. INCREMENTS.
014 5250145	132	EACH TRACK FOOT INCLUDES 2 GADE SIDE AND 2 FIELD SIDE SECTIONS. INTERFACE DELIVERED IN 8' SECTIONS.
014 5250145	136	
014 5250145	140	
014 5250170	141	
042 1150010	115 -122	CROSSING TIMBER 10" WIDE, 8'-1 1/2' LONG, 4" TIMBERS PER BUNDLE, ORDER BY TRACK FEET.
042 1320010	132	
042 1360010	136 -141	
013 8230080	ALL	SCREW, TIMBER 3/8" x 12" WITH TORX SQUARE WASHER HEAD.



NORMAL DUTY ROAD CROSSING  
RUBBER, ASPHALT AND TIMBER ON WOOD TIES

APPROVED: [Signature] DIRECTOR  
ENGINEERING STANDARDS  
ENGINEERING SERVICES

PREPARED BY: [Signature]  
C. S. MOALE

ISSUED: MARCH 22, 2005  
REVISED: APRIL 7, 2016

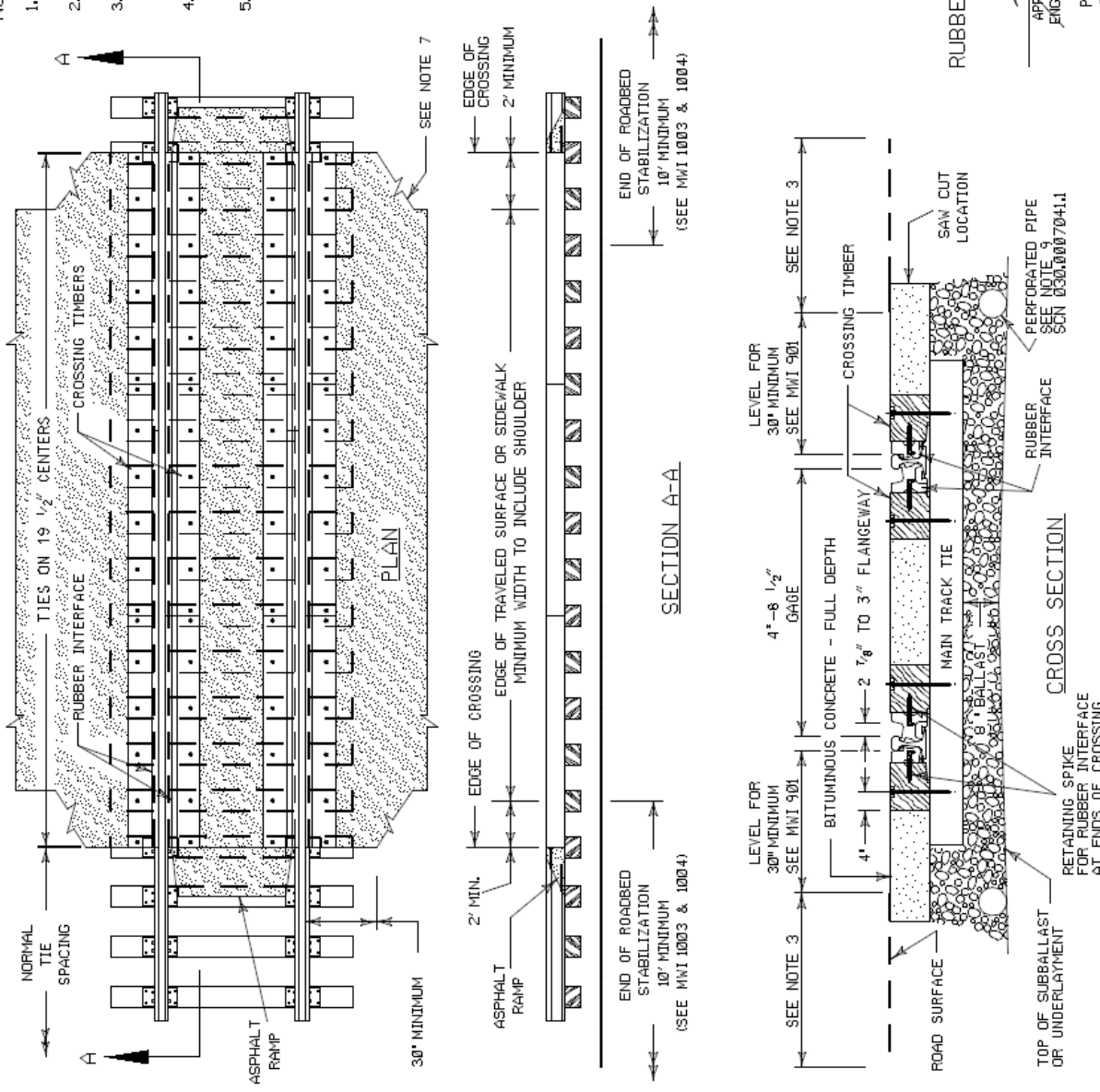

2535  
SHEET 2

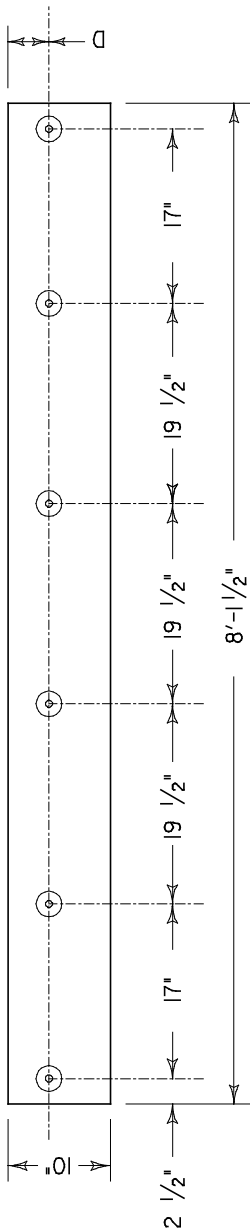

NOTES

1. TIMBERS ARE NOT PREDRILLED UNLESS SPECIFIED IN THE REQUISITION.
2. TOLERANCES:  
TIE PLATE CUT-OUT AND "H" - 1/8" +/-  
OTHER - 1/4" +/-
3. MATERIAL:  
OAK OR GUM  
TREAT PER MW SPEC 99001
4. TIMBERS TO BE MARKED FOR RAIL SIZE

PLAN VIEW

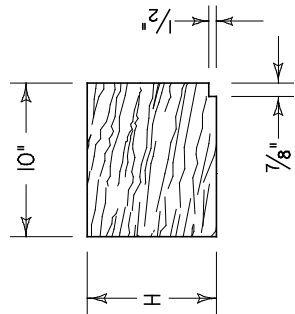

END VIEW  
GAGE SIDE TIMBER

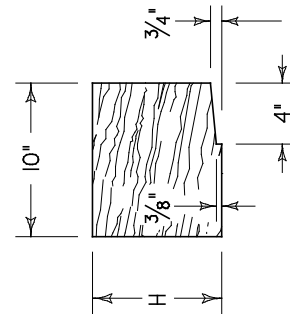

END VIEW  
FIELD SIDE TIMBER

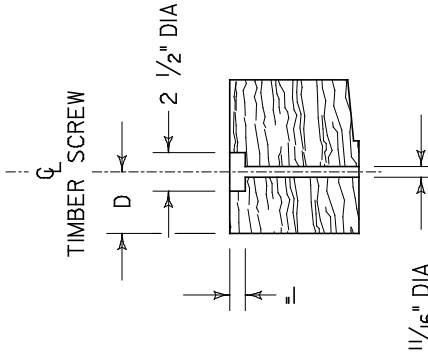

TYPICAL SECTION AT  
TIMBER SCREW LOCATION

RAIL WGT.	H
115-122	7 1/2"
132	8"
136-141	8 3/8"

SIDE	D
GAGE	5"
FIELD	4"



RUBBER, ASPHALT AND TIMBER CROSSING  
CROSSING TIMBER DETAILS

**K.A. Donald**  
APPROVED - CHIEF ENGINEER  
MAINTENANCE OF WAY

*James D. Boyles*  
APPROVED - VICE PRESIDENT  
ENGINEERING

ISSUED: MARCH 22, 2005  
REVISED: APRIL 11, 2007

PREPARED BY:  
J. E. BEYERL

NOTES

2536  
SHEET 1

1. MW1901(LATEST REVISION) IS TO BE USED IN CONJUNCTION WITH THIS DRAWING.
2. FOR NEW CONSTRUCTION, HIGHWAY SHOULD INTERSECT RAILROAD AT OR NEARLY RIGHT ANGLES.
3. FOR NEW CONSTRUCTION, HIGHWAY SURFACE SHOULD NOT BE MORE THAN 3" HIGHER OR LOWER THAN TOP OF THE NEAR RAIL 30' FROM THE RAIL ALONG THE ROAD CENTERLINE, UNLESS TRACK SUPERELEVATION DICTATES OTHERWISE.
4. USE STATE D.O.T. SPECIFICATIONS FOR BITUMINOUS CONCRETE AND ASPHALT SPRAY TACK COAT FOR THE STATE IN WHICH THE CROSSING IS LOCATED.
5. CROSSINGS SHOULD BE CONTINUOUS BETWEEN ROADWAY OR SIDEWALK EDGES. IF NOT PRACTICABLE, ADEQUATE DRAINAGE MUST BE PROVIDED BETWEEN CROSSING AREAS TO ELIMINATE WATER POCKETS.
6. SLOPE PAVING TO RETURN TO ORIGINAL PAVEMENT SURFACE. LENGTH OF TRANSITION WILL DEPEND ON LOCAL CONDITIONS. USE A RUNOFF OF 1 IN. PER 10 FT. WHERE PRACTICABLE.
7. IF ROADBED STABILIZATION IS REQUIRED, EXTEND IT 10 FT. BEYOND EDGE OF CROSSING UNDER TRACK.
8. DRILL CROSSING TIMBERS OVER EACH TIE FOR TIMBER COUNTERSINK.
9. PERFORATED PIPE TO BE INSTALLED WHERE OUTFALL IS PERMITTED TO PROVIDE POSITIVE DRAINAGE FROM TRACK STRUCTURE AND SUBGRADE. USE MIN. 4" DIA. PIPE AND LOCATE AT LEAST 12" BEYOND THE END OF TIE.

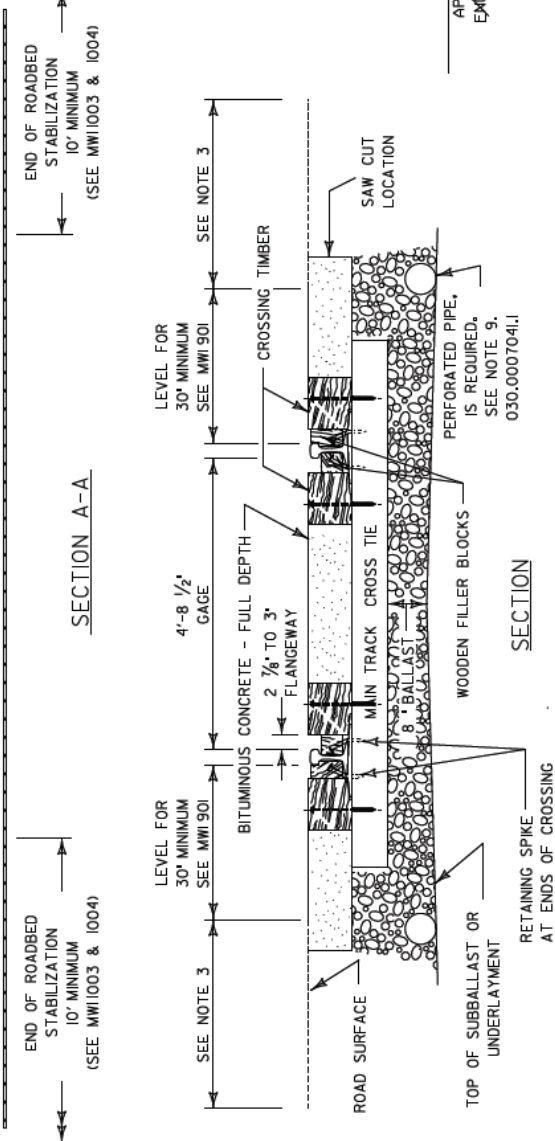
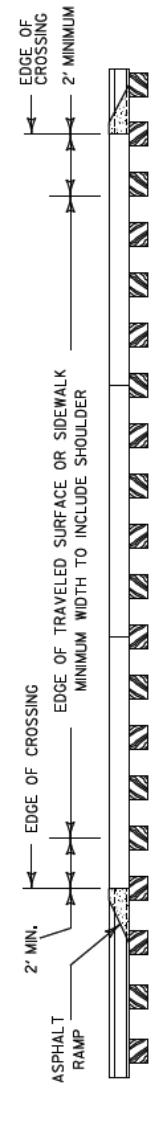
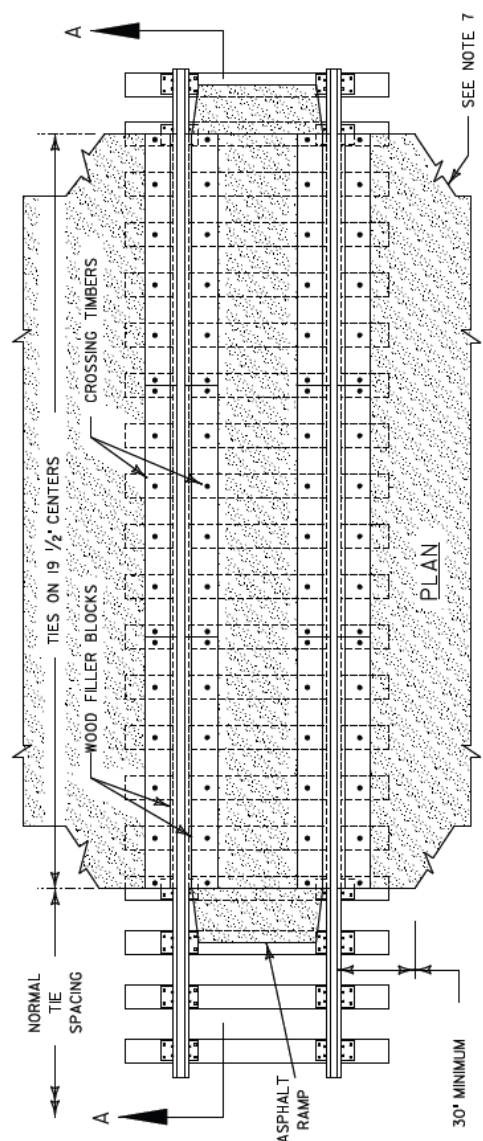

ITEM NO.	RAIL WGT.	DESCRIPTION
042 3060115	115	CROSSING TIMBER / WOOD FILLER, CROSS BY TRACK FEET IN APPROXIMATE FEET INCREMENTS.
042 1320132	132	EACH TRACK FOOT INCLUDES 4 TIMBER SECTIONS
042 1360136	136	AND 4 FILLER BLOCK PIECES, DELIVERED IN 8'-1 1/2' LONG SECTIONS.
042 1360140	140	
042 1360141	141	
013 8230080	ALL	SCREW, TIMBER 3/8" x 12" WITH TORX SQUARE WASHER HEAD.



NORMAL DUTY ROAD CROSSING  
TIMBER AND ASPHALT ON WOOD TIES

APPROVED: DIRECTOR  
ENGINEERING STANDARDS

APPROVED - CHIEF ENGINEER  
ENGINEERING SERVICES

PREPARED BY:  
M.E. AUSTIN

ISSUED: MARCH 22, 2005  
REVISED: APRIL 7, 2016

2536  
SHEET 2

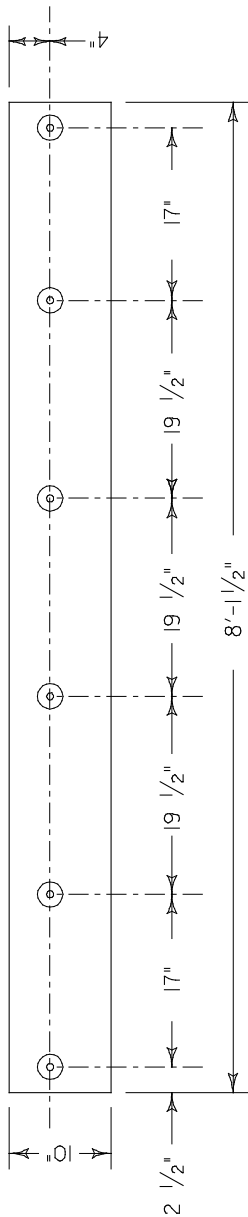

NOTES

1. TIMBERS ARE NOT PREDRILLED UNLESS SPECIFIED IN THE REQUISITION.
2. GAGE AND FIELD TIMBERS ARE IDENTICAL.
3. TOLERANCES:  
A, E, AND G : 1/16" +/-  
ALL OTHERS : 1/8" +/-
4. CROSSING TIMBER TO BE OAK OR GUM. TREATMENT PER MW SPEC 99001 LIKE CROSSTIES
5. FILLER BLOCKS TO BE SOUTHERN YELLOW PINE GRADE 2 WITH 10 LB / CU FT TREATMENT
6. TIMBERS & FILLERS TO BE MARKED FOR RAIL SIZE

CROSSING TIMBER PLAN VIEW

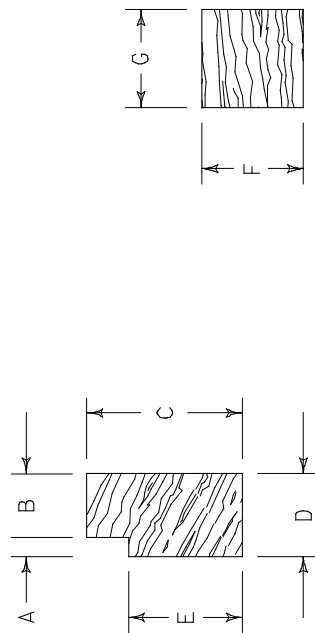

RAIL WGT	A	B	C	D	E	F	G	H
115 RE	3/4	2 3/4	5 3/8	3 1/2	3 7/8	3 3/8	4	7 1/2
122 CB	3/4	2 3/4	5 5/8	3 1/2	4	3 5/8	4	7 1/2
132 RE	5/8	2 7/8	6	3 1/2	4 1/2	3 7/8	3 7/8	8
136 RE	5/8	2 7/8	6 1/4	3 1/2	4 1/2	3 7/8	3 7/8	8 3/8
140 RE	3/4	2 3/4	6 1/16	3 1/2	4 5/16	3 7/8	4	8 3/8
141 RE	11/16	2 13/16	6 3/8	3 1/2	4 1/2	3 7/8	3 7/8	8 3/8

ALL DIMENSIONS ARE IN INCHES.

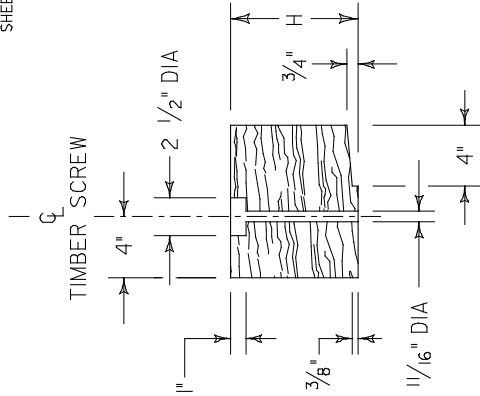

CROSSING TIMBER SECTION AT SCREW LOCATION



TIMBER AND ASPHALT CROSSING  
CROSSING TIMBER AND FILLER BLOCK DETAILS

*J. Kopylov*  
APPROVED - CHIEF ENGINEER  
MAINTENANCE OF WAY

*James D. Barclay*  
APPROVED - VICE PRESIDENT  
ENGINEERING

ISSUED: MARCH 22, 2005  
REVISED: NOVEMBER 14, 2005

PREPARED BY:  
J. E. BEYERL

Diagram: Bridge Approach Ties (2607)

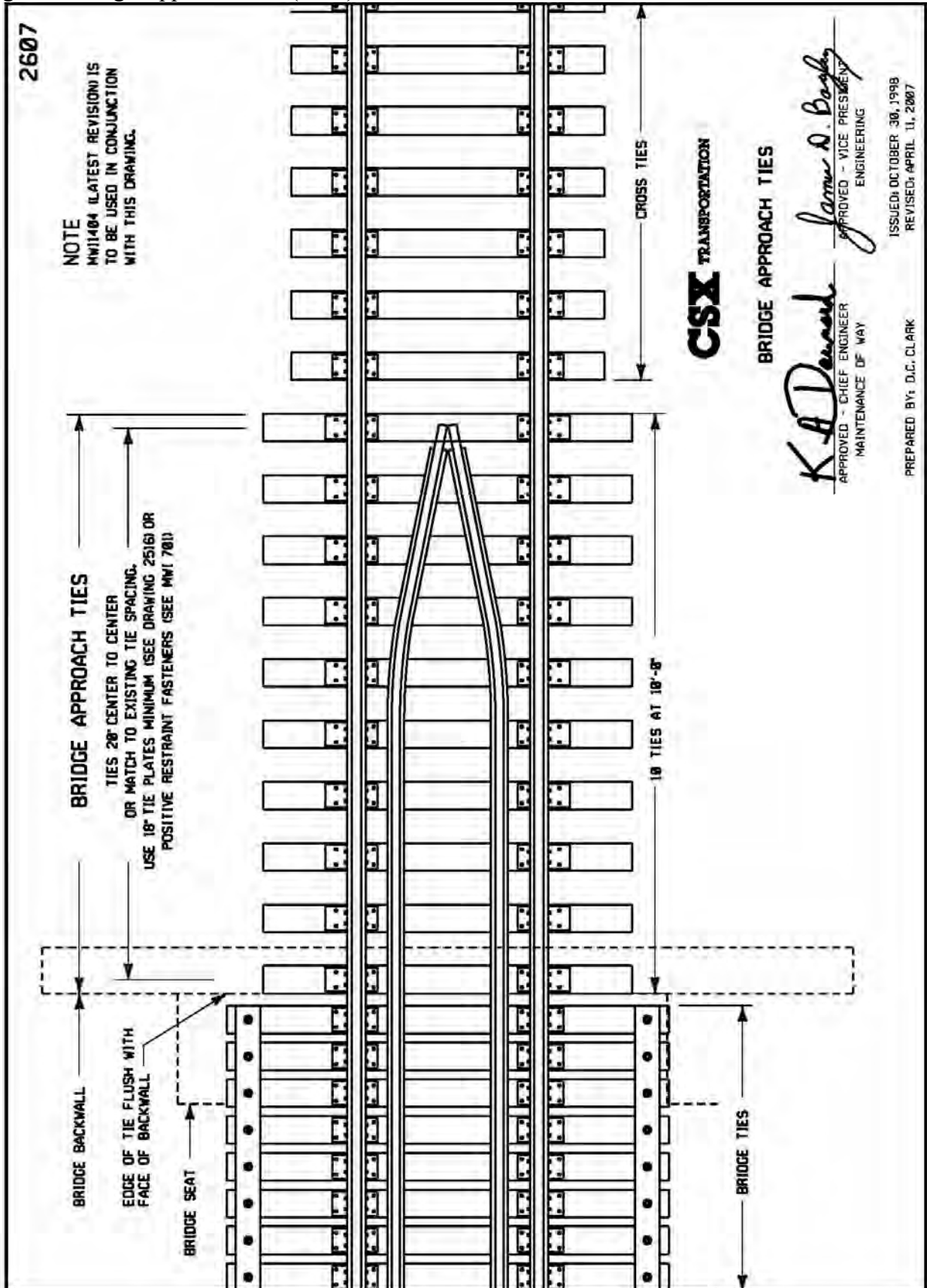

## Grading

### A) GENERAL

#### Scope

These specifications cover clearing, grubbing, excavations (cuts), embankments (fills), drainage, subballast, erosion protection, and geotextiles associated with the construction of private tracks served by CSXT.

All work and materials shall conform to these specifications and to any supplemental specifications pertaining to the particular project. Where there is any conflict between specifications, those pertaining to the particular project shall govern.

All references to “the Contractor” shall refer to any Contractor or subcontractor working on the Industry’s behalf during the construction of the sidetrack.

Prior to commencing work on CSXT’s right-of-way, the proper written authority must be given to the industry and/or Contractor. The primary method of conveying authority is via the sidetrack agreement that must be executed between CSXT and the Industry. A right-of-entry for surveying and preliminary non-construction activities is available and information on obtaining this authority is detailed elsewhere in this document.

#### Permits and Right of Entry

The Contractor shall seek permission from and coordinate with any individual, governmental body, (including environmental agencies), utility, etc., upon whose property the Contractor must enter or perform work.

The Contractor will secure all permits, such as environmental, grading, cut and fill, waste disposal, and street opening which may be required by governmental agencies having jurisdiction.

#### Fiber Optic Cable

Underground Fiber Optic Cable installations (longitudinal occupations on Railroad right of way) may require relocation, lowering, and/or protective casing installation. If there are Fiber Optic Cable markers in the area of the proposed side track(s), contact CSXT’s Director of Corridor Occupancy Services at (904) 279-3843 for the name and phone number of the involved cable company’s representative.

The Fiber Optic Company must be contacted and any work needed to protect the cable must be performed by the Fiber Optic Company prior to commencement of any grading work that may affect the installation. As with all underground utilities, the industry is responsible for contacting the state’s one-call/before you dig hotline and/or the utility company directly prior to work that penetrates the ground.

#### Line and Grade

All work shall conform to the alignment, grades, cross sections, and slopes shown by the plans approved by CSXT. The center of the roadbed will conform to the alignment (horizontal and vertical) indicated on the drawings. The grade line on the profile denotes the subgrade and the finished embankment or the bottom of the excavation ready to receive the subballast or geotextile.

The roadbed will be constructed to the dimensions shown on the current CSXT drawing titled “Standard Roadbed and Ballast Section” pages 19, 20, and 21.



## B) CLEARING AND GRUBBING

### Clearing

Clearing will consist of the cutting of all trees, stumps, brush, shrubs, and other vegetation at a level not more than 12 inches above ground and the disposal of all cut material and other fallen timber, fallen branches and other surface litter, rubbish, and debris.

### Grubbing

Grubbing will consist of the removal and disposal of all stumps, roots, root mats, embedded logs, and all boulders and debris visible on the surface where clearing is to be done. Stumps will be grubbed where embankments are less than 5 feet in height; where the profile indicates excavation; in all areas designated for the construction of other facilities; and in borrow areas. In all other areas, the stumps may be cut off even with the ground.

### Methods

In felling trees near tracks, structures, and wire lines, necessary precautions must be exercised in order to prevent damage to these facilities or the obstruction of tracks. This may require flagging protection when felling trees near tracks.

## C) EXCAVATION

### Methods

Slopes of all excavations shall be cut true and straight and all loose stones in the slopes shall be removed. Rock shall be removed below sub-grade and the area refilled with approved materials. The Contractor shall take whatever measures may be necessary to properly drain the excavations during and after construction to prevent water from flowing into, or standing in the excavations for any appreciable time, whether it be storm or ground water.

Rock excavation shall be removed to a depth of eighteen (18) inches below subgrade and refilled with suitable material. Where required, unsuitable material in the bottom of cuts will be removed and refilled to subgrade with acceptable material.

### Disposal of Excess Excavation

Where the quantity of excavation exceeds that required to construct the embankments to a standard cross section, the surplus may be used to widen the embankments uniformly along one or both sides.

### Waste Area

Waste areas for the disposal of excess or unsuitable material will be located and materials deposited to not endanger the roadway. Material shall not be wasted on CSXT property under any circumstances.

D) UNSUITABLE MATERIAL

Should unsuitable material be encountered, such as muck, highly plastic clays, or silty unstable material, it shall be removed. In cut sections, plastic material, as defined by the American Association of State Highway and Transportation Officials (AASHTO) - Soil Classification System as Group A-2-6, A-2-7, A-4, A-5, A-6, or A-7 shall be removed to a depth of at least 2 feet below subgrade from ditch line to ditch line. Additional depth may be required depending upon local conditions. Where organic muck, Group Classification A-8, is encountered in the fill section, it shall be removed within the limits of the toes of slope of the roadbed. Where fill exceeds 10 feet in height, width of the section to be excavated shall be three times the height of the fill. After removal, all unsuitable material shall be distributed along the lower portion of the embankments and dressed to give a uniform pleasing appearance or wasted.

E) EMBANKMENTS

Materials

Suitable excavated material shall be used in forming the embankments. The material to be used in embankments shall be free of frozen or organic materials such as leaves, roots, grass, weeds, and all other material not consistent with construction of a stable, homogeneous fill. Embankments will not be constructed on frozen ground.

Formation in Layers

Unless otherwise provided, embankments shall be constructed in successive layers no more than 6 inches thick, loose measurement. Benching is required to widen existing embankments or fills. Where embankments are built by dumping from draglines, trucks, or other similar equipment, a bulldozer must be operated constantly to spread the material. These layers must be the full width of embankment, each thoroughly compacted, built to the true slope, and not widened with loose material from the top. When embankments are being constructed principally of rock, the depth of each layer shall be carefully distributed throughout the embankment, and the voids shall be filled with fine material to secure the maximum density. The most suitable material shall be reserved for finishing the roadbed.

Large stones with any dimension greater than six inches shall not be permitted within two (2) feet of the design subgrade. As the embankment is consolidated, the slopes shall be carefully dressed to the desired section and maintained to their proper height, dimensions, and shape until the work is accepted. Where a new embankment is to be placed on sloping ground or on an existing roadbed embankment, the surface shall be deeply plowed and stepped. When transporting material with rubber-tired equipment, care shall be taken to see that the trailing units do not follow in the tracks of the preceding unit. At the end of each day's work the embankment shall be dressed to shed any water that might fall during the night.

Density

Suitable compaction equipment shall be continuously operated while embankments are being constructed. While work is progressing in separate areas, approved compaction equipment shall be operated continuously in each embankment area. **Compaction of the embankments shall be to density of 95 per cent of that obtained in a Modified Proctor Density Test, ASTM D-1557.** Material that does not contain adequate moisture to obtain specified density shall require the incorporation of additional water. Material containing an excess amount of moisture shall not be placed in an embankment until it has been allowed to dry to the design moisture content.

## Shrinkage

The Contractor shall construct embankments to such heights above subgrade and to such increased widths as are necessary to provide for shrinkage, subsidence, and erosion. As the embankments become consolidated, their sides shall be trimmed to the proper dimensions and shapes until the completion and acceptance of the work.

## Embankments Over/Around Structures

Wet or impervious materials will not be permitted for forming embankments about, against, or over structures. The materials shall be deposited in layers of not more than six (6) inches in thickness, carefully tamped, and sloped away from the structure. Fill over arches, boxes, and large pipes shall be deposited uniformly on both sides. Large stones shall not be placed within two (2) feet of the extrados of any arch, top, and sides of boxes, or outside of large pipes. Any damage to waterproofing shall be repaired.

### F) DITCHES

Intercepting and berm ditches shall be provided at the top of the cut slopes and the toe of the embankment slopes to divert storm water that flows toward the roadbed. Roadbed ditches shall be provided as indicated with the outfall ends diverging sufficiently to prevent erosion of the adjoining embankments. All ditches shall be in accordance with CSXT Standard Roadbed and Ballast Section, page 19, 20, and 21.

### G) FINISHED SUBGRADE

The subgrade shall be compacted and finished to a true, level, sloped or crowned surface as called for by the drawings, and must leave no depression or irregularity which will hold water or prevent proper drainage. A tolerance of not more than one-tenth (0.10) foot above or below design subgrade will be permitted.

**See CSXT Required Grading at Turnout, for typical subgrade section and grading requirements at turnout constructed in CSXT track.**

### H) SUBBALLAST

The finished track roadbed shall receive compacted sub-ballast as indicated on CSXT's Standard Roadbed Section Drawing unless otherwise indicated on project drawings.

**The sub-ballast density shall be 95 percent based on the Modified Proctor Density Test ASTM 1557.** If additional moisture is required to obtain adequate density, the Contractor shall use water along with approved mixing, shaping and compaction equipment. The subballast shall be finished to a tolerance of one-tenth (0.10) foot above or below design subgrade elevation. The Contractor shall not place sub-ballast on a wet or rutted roadbed.

### I) GEOTEXTILES

The geotextile, when specified, shall be placed on the finished subgrade before the sub-ballast is placed and compacted. No equipment shall be allowed to operate directly on the bare geotextile. The geotextile shall be placed symmetrically about the track centerline. At the end of each roll or piece of geotextile, there shall be a two-foot overlap of the material. Special care shall be taken by the Contractor in placing the geotextile on the finished subgrade to ensure that the geotextile is laid flat and free of wrinkles.

If the geotextile is damaged in any way, the Contractor shall place a patch of the same material over the damaged area. The patch shall have a two-foot overlap in every direction around the damaged area.

If it is necessary to overlap rolls or pieces of a geotextile along the longitudinal edge, eighteen (18) inches of overlap shall be used. No longitudinal overlaps shall occur between the toes of ballast of any track.

At all bridge abutments the geotextile shall be turned down two feet below the finished subgrade against the face of the abutment. As the embankment is replaced against the abutment and the geotextile, the Contractor shall take special care to ensure that the backfill is adequately compacted to the specified design density. The Contractor shall also use special care to avoid any damage to the geotextile.

Specifications for each particular application of geotextile and guidelines for their installation are found in CSXT's MWI 1003, latest edition, available upon written request.

## J) PIPE CULVERTS

### General

Trench excavation shall be true to the lines and grades shown on the drawings and carefully graded by hand whenever necessary to properly install the culverts. Rocks or other material, which might prove injurious to the culverts, shall be removed from the culvert bed. All pipe culverts shall have a minimum cover of 2.5' measured between the top of pipe and bottom of crosstie.

### Concrete Pipe

All reinforced concrete pipe shall be bell and spigot pipe with "O" ring gasket or tongue and groove with RAM-NEK type flexible gasket meeting the current ASTM designation C-76 or as specified. Concrete pipe under tracks shall be Class V.

### Corrugated Metal Pipe

Corrugated metal pipe will be fully asphaltic coated (AASHTO M190, ASTM A849) or fully coated with other approved corrosive resistant material. Fiber bonded (ASTM A885) pipe will be provided where specified for placement in tidal waters, where acid mine drainage may be encountered or where other conditions warrant. Fully asphalt coated and paved or polymer pre-coated (AASHTO M245, ASTM A742) pipe is required in streambeds with moderate to severe bedloads of sand, gravel, and rock with velocities in excess of 5 feet per second.

A minimum of 24" long connecting bands shall be used to connect CMP. Gage of pipe to be used as follows:

**Table 4: Corrugated Metal Pipe Specifications**

Dia	Gage	Wall Thickness	Cover Limits
12"	16	0.064"	2.5' to 50'
15"	16		2.5'to 40'
18"	14	0.079"	2.5'to 50'
21"	14		2.5'to 45'
24"	14		2.5'to 40'
30"	12	0.109"	2.5'to 55'
36"	12		2.5'to 40'
42"	12		2.5'to 50'
48"	12		2.5'to 45'
54"	10	0.138"	2.5'to 45'
60"	10		2.5'to 45'
66"	10		2.5'to 45'
72"	8	0.168"	2.5'to 50'
78"	8		2.5'to 45'
84"	8		2.5'to 40'

**Note: 12"to 30" CMP shall not be used under CSXT owned track.**

**Table 5: Elliptical Metal Pipe Specifications**

Span & Rise	Gage	Thickness	*Cover Limits
18" x 11"	14	0.079"	2.5'to 50'
22" x 13"	14		2.5'to 45'
25" x 16"	14		2.5'to 40'
29" x 18"	12	0.109"	2.5'to 55'
36" x 22"	12		2.5'to 45'
43" x 27"	12		2.5'to 40'
50" x 31"	10	0.138"	2.5'to 60'
58" x 36"	10		2.5'to 55'
65" x 40"	10		2.5'to 50'
72" x 44"	8	0.168"	2.5'to 60'
79" x 49"	8		2.5'to 55'
85" x 54"	8		2.5'to 50'

**\*Note: Cover limits measured from bottom of tie.**

#### Other Material

HDPE, PVC, or ABS "plastic" pipe may be used only with CSXT approval for specific application.

#### Bedding & Placement

Local selected material may be used as backfill and it shall be free from large rocks, lumps, and debris. No frozen fill, sod, cinders, or material containing a high percentage of organic material shall be allowed. Material under the haunches and around the culvert shall be placed in layers not exceeding 6 inches. The layers are to be alternately placed to keep the same elevation on both sides of the culvert at all times. Compaction under the haunches shall be accomplished by utilizing a pole or 2" x 4" timber in the small

areas. Hand tampers shall weigh not less than 20 pounds and have a tamping face not larger than 6" x 6". Mechanical tampers and rollers shall be used in bringing the backfill up to at least 3 feet above the culvert. They shall not strike the culverts while tamping. Smooth rollers will not be allowed in compacting fills around or over culverts.

## K) EROSION PROTECTION

Note: These are minimum CSXT guidelines and governmental agencies' requirements may vary and/or be more stringent.

### Seeding

Unless otherwise provided, all roadbed slopes shall be prepared, fertilized, seeded, and mulched to produce a stand of erosion protection grass of an annual variety.

### Rip-rap

Description: This work consists of the installation of the required material for a protective covering of stream channel slopes at culvert inlets and outlets and embankment slopes.

Material: Rip-rap will consist of dense, sound, durable, angular shaped stone, ranging in size from 1/4 cubic foot in volume to sixteen cubic feet in volume, except that stones of smaller size, not exceeding 15 percent of the total volume, may be used for filling the voids. Rip-rap will be free from overburden, spoil, shale, and organic matter.

Installation: Rip-rap will be placed in rechanneled areas and in all areas where the fill is in contact with streams. Rip-rap shall be placed a minimum of three feet thick on side slopes measured perpendicular to the slope in accordance with Project Plans. Rip-rap will be placed concurrently with embankments and channel relocation.

### Temporary Silt Fence

Description: The work covered by this section consists of furnishing, installing, maintaining, and removing a water permeable filter type fence to remove suspended particles from the drainage water.

Materials: All materials shall comply with applicable specifications of the local State Department of Transportation or with the industry's environmental permitting requirements.

Installation: The Contractor shall install temporary silt fence as shown on the plans. Posts will be spaced 6-10 feet apart depending on the amount of flow expected. Posts will be installed a minimum of 2 feet in the ground. Filter fabric will be attached to the wire fence or post by wire, cord, or staples. The filter fabric will be installed in such a manner that 4 to 6 inches of fabric is left at the bottom to be buried and a minimum overlap of 18 inches is provided at all splices.

Maintenance and Removal: The Contractor shall maintain the silt fence until the project is accepted or until the fence is removed. Contractor shall remove and dispose of silt accumulations along the fence when the capacity of the fence is diminished. Filter fabric shall be replaced when it has deteriorated to such extent that it is no longer effective. Upon removal of the silt fence, the Contractor shall dress the area to give a pleasing appearance, and shall seed and mulch the area in accordance with **Section "Seeding"**.

L) TEMPORARY CROSSINGS

When a temporary crossing is necessary to transport material across the track or tracks, the location and construction of the crossing must be approved by CSXT. Temporary crossings installed over tracks that are owned by CSXT shall be installed and removed by CSXT forces only after a separate private crossing agreement is in place. Temporary crossings over tracks not owned by CSXT shall be installed and removed by the Contractor. The cost of all crossings whether by CSXT or the Contractor shall be the responsibility of the Contractor.

M) PROTECTION

Watchmen and flagmen shall be provided, at the expense of the Contractor, by CSXT when CSXT considers it necessary for the safety of trains and highway traffic or for any other operations. The Contractor shall provide the CSXT Engineering Department 30 days advance notice of the need of a watchmen or flagmen.

N) SAFETY OF AND DELAY TO TRAINS

All work performed by the industry shall be so arranged that there will be no delay or interference in any manner with the operation of trains. The work shall not cause any interference with signal wires, cables, fiber optic, telephone, or other wire lines.

Whenever the work is likely to affect the movement or safety of trains, the method for doing such work must be submitted for approval, without which it must not be commenced or prosecuted.

Blasting adjacent to CSXT's tracks is not permitted.

O) ACCESS

Suitable access roads as necessary shall be provided at the expense of the Contractor to provide ingress and egress to the site of the work. The Contractor shall also provide and/or maintain any public or private roads that may be used in the process of the work.

## Materials

### A) GENERAL

Track, roadbed, and structures shall be constructed to the line and grade as shown on the approved final plans. Inspection and approval of the completed track shall be made by qualified CSXT Engineering personnel and shall not be placed in service without such approval. Inspection shall include grading, drainage, structures, clearances, track, and related appurtenances to assure satisfactory compliance with approved final plan and CSXT Standards for construction and safety.

### B) SCOPE

These specifications shall apply to that portion of the sidetrack owned and maintained by the industry (typically beyond the derail) whether constructed by the industry or the industry's Contractor.

### C) SUBBALLAST

Subballast shall be composed of crusher run granite or limestone and shall meet the requirements as set out in Chapter 1 (Roadway and Ballast) Part 2 (Ballast), Section 2.11 (Sub-Ballast Specifications) of the current AREMA Manual. Sub-Ballast material shall conform to the gradation requirements as shown in **Table 6**.

Description: Any material of a superior character spread on the finished sub-grade of the roadbed and below the ballast to provide better drainage and bearing characteristics than afforded by the sub-grade material.

**Table 6: Subballast Gradation Requirements**

SCREEN SIZE	PERCENT BY WEIGHT PASSING	
	Graded Aggregate.	Crusher Run
1 1/2"	100%	100%
3/4"	60-100%	
No.10	30-55%	15-45%
No.60	8-35%	
No.200	5-12%	5-12%



D) BALLAST

Material shall be limestone, dolomite, or granite material free of loams, dust, or other foreign particles. Material shall be designated as AREMA #4A or #5, in accordance with gradation chart shown below.

The size of ballast to be used shall be AREMA #4A in main tracks, lead tracks, and sidings. AREMA #4A ballast will also be used between the top of the subballast and the bottom of crossties in industrial tracks, spurs, and yard tracks. AREMA #5 will be used to fill the cribs and shoulders in industrial tracks, spurs, and yard tracks (see drawing 2602 on page 20). Ballast shall conform to the grading requirements as shown in Table 7.

**Table 7: Track Ballast Gradation Requirements**

	PERCENT BY WEIGHT PASSING	
	MAINTRACK	WALKWAY
<b><u>Screen Size</u></b>	<b><u>AREMA 4A</u></b>	<b><u>AREMA 5</u></b>
2 ½"	100%	
2	90-100%	
1 ½"	60-90%	100%
1"	10-30%	90-100%
¾"	0-10%	40-75%
½"		15-35%
3/8"	0-2%	0-15%
No.4		0-5%

E) TIES

The use of steel, concrete, and composite crossties for industry owned tracks and turnouts are permitted. The use of steel, concrete, and composite ties in industrial tracks should be noted on the plans, along with the manufacturer of the product. The industry shall consult with and follow the manufacturer’s guidelines for installation and maintenance of steel and concrete crossties.

Wood Crossties

All crossties will be treated per A.W.P.A. Manual C-6 to a net retention of 7 lb./cu.ft. for oak and 8 1/2 lb./cu.ft for mixed hardwoods, and will conform to AREMA Manual, Chapter 3. All ties shall be free from any defects that might impair their strength or durability as crossties, such as decay, large splits, large shakes, slanting grain or large numerous holes or knots.

For applications below mid-Alabama and mid-Georgia, the industry should consider borate treated ties to decrease decay experienced in these areas.

Mainline crossties shall be size 5 (7"x 9"x 8'6" long, minimum 8" face), or size 4 (7"x 8"x 8'6" long, minimum 7 1/2" face). Sidetrack crossties shall be a minimum size 3 (6"x 8"x 8'6" long, minimum 7" face).

### Switch Ties

Switch ties shall be pressure treated as specified above. The switch ties shall be of 7"x 9" cross-section and shall vary in length as per the specified turnout design.

### Types of Wood

The following is a list of the species of wood acceptable for ties.

Ash	Elm	Locust	Sassafras
Beech	Gum	Maple	Walnut
Birch	Hackberry	Mulberry	
Cherry	Hickory	Oak*	

\*NOTE: White Oak is not acceptable south of Tennessee and North Carolina

#### F) TIE PLATES

Tie plates with an 8-hole punch compatible with the approved rail section shall be used on all ties, except in turnouts and track crossings where special plates are required. For all rail sections, double shoulder tie plates with 1:40 cant shall be used.

#### G) RAIL

Rail shall be new or second-hand, with minimum section of 100 pounds per yard and be appropriate for the operational requirements; however, it is advised for the industry to investigate the economics of using a heavier rail section for reduced maintenance and life cycle costs. Full length rail shall be used except in cutting closures and installing turnouts or crossings. No rail shorter than thirty three (33) feet long on curves and nineteen feet six inches (19'-6") on tangents shall be used except in turnouts and track crossings. All rail used in the sidetrack shall be control cooled rail; **non-control cooled rail shall not be used.** *CSXT specifies "RE" section rail exclusively when constructing or maintaining CSXT owned tracks.* When CSXT is to construct the turnout or any portion of a private track, "RE" rail will be used. If an industry or the industry's Contractor wishes to use another section, such as "DY" or "CB", the industry or Contractor must:

- Obtain approval of CSXT for the specified section.
- Provide tie plates, joint bars, and other track material designed for that section.
- Provide, at industry expense, compromise joints for joining specified section with "RE" rail section installed in turnout or track constructed by CSXT

Frequently an industry served by CSXT will request assistance in "emergency" repair to the sidetrack serving their facility. If the private track contains rail with a section other than "RE", CSXT maintenance forces will not have the proper material to assist with such repairs. The industry must be prepared to provide material to CSXT forces if emergency repairs are needed.

Certain facilities based upon traffic volume and/or commodity may require usage of Continuously Welded Rail (CWR) at the discretion of the CSXT Engineering Department.

### Splices

Joint bars designed for the specified rail section shall be installed and fully bolted. Six-hole joint bars shall be used with all rail sections. Unless the track is to be welded, all six holes of the bar must be bolted. Four-hole joint bars may be used only if approved by CSXT's Chief Engineer Design, Construction, and Capacity.

### Insulated and Compromise Joints

All insulated joints shall be of the types and sizes specified and shall be in accordance with CSXT Standards. The entire surface of the rail covered by the insulated joints must be thoroughly cleaned of rust, scale, and dirt. Insulated joints must be suspended between sound smooth ties, well tamped, and well drained. Compromise joints shall not be used on curves, bridges, or in that portion of turnouts laid on switch ties. Compromise welds may be used in place of compromise joints.

**Compromise joints connecting private track containing rail of any section other than "RE" shall be provided by the industry or the industry's Contractor.**

### Track Bolts

SAE Grade 8 button head oval neck bolts shall be used for all track joints.

### Washers

Spring washers of the appropriate size and conforming to AREMA recommendations found in Chapter 4 (Rail) shall be used on each bolt.

### Spikes

High-carbon steel track spikes shall be used and conform to AREMA recommendations found in Chapter 5 (Track), Part 2 (Track Spikes). Track spikes shall be 5/8" square by 6" long, unless otherwise approved by CSXT.

### Anchors

Rail anchors shall be drive on or spring type, of approved design, conforming to AREMA recommendation found in Chapter 5 (Track), Part 7 (Rail Anchors). New or approved reclaimed rail anchors shall be used. Where used with relay rail, the anchors must be sized to fit the rail base.

## H) TURNOUTS

This section deals with turnouts constructed by industry or industry's Contractor diverging from track owned and maintained by the industry. All turnout material shall be of no lighter rail section than the rail section from which it diverges (100# minimum) and shall be subject to the inspection and approval of CSXT. The minimum size of frog used in a turnout diverging from a sidetrack, shall not be less than a number 8. The type of switch and frog for each turnout to be constructed in CSXT owned track shall be in accordance with CSXT Standard Drawings. AREMA standard turnouts, of not less than number 8 frog size, may be used in industry owned tracks. As with rail, industry must provide material for AREMA standard turnouts when CSXT forces are needed for emergency repairs. Material for turnouts diverging from track owned and maintained by CSXT will be supplied by CSXT.

### Switch Stands

Switch stands for turnouts and derails on Industry owned portion of track shall be Low New Century Model 51-A or approved equal. Switch stands located in industry tracks shall be equipped with an ergonomic switch handle (**bow handle**), target, mast, latches, and connecting rods adjusted for proper throw (note bow handle switch handles shall be not located in turnouts in the mainline or passing sidings). Switch targets will be used on all hand-operated switches and switch stand operated derails. The targets for industrial turnouts shall be green/yellow (with green directed toward straight move) and derails shall be green/red (with green directed toward a non-derailing movement). Switch stand cranks must be single use and made of forged steel; double use malleable iron cranks are prohibited. Switch stands and latches shall be secured to switch ties according to manufacturer's recommendations.

### Point Guards

All industry owned turnouts shall include switch point guards (not protectors) installed as recommended by their manufacturer. Switch point guards will not be installed on mainline turnouts. A switch point guard is a special piece of trackwork that is raised above the head of the rail and is installed adjacent to a switch point; it is not a block of manganese bolted to the rail ahead of a switch point.

#### I) DERAILS

Derails shall be compatible with rail section used and shall be subject to the inspection and approval of CSXT. Stands for derails shall be similar to the switch stands (see above). Industrial supplied sliding or hinged derail used to protect customer's loading and unloading operations shall be painted yellow.

#### J) BUMPING POSTS

Material shall be of a type approved by CSXT and shall be installed at the end of tracks, where applicable. Bumping posts shall be painted yellow.



U.S. Department  
Of Transportation

**Federal Railroad  
Administration**

---

# **RAILROAD CORRIDOR TRANSPORTATION PLANS**

## **A GUIDANCE MANUAL**

NOTICE: This document is a technical working paper by the staff of the Federal Railroad Administration (FRA). As such, it is not intended to be a policy document. It is disseminated by the FRA staff solely in the interest of technical information exchange, for the benefit of States and other interested entities that may be undertaking corridor transportation plans. The United States Government assumes no liability for its contents or use thereof.

# Corridor Transportation Plans

## I. Introduction

This paper provides guidance to proponents of new or improved high-speed intercity rail services or systems. The Federal Railroad Administration makes this paper available to suggest the level of analysis and planning necessary to progress a program or project of this type. In the past, the Federal Railroad Administration and Amtrak have collaborated on a number of occasions to prepare a long range planning document for various rail corridors that have been called master plans or transportation plans. These studies attempt to take into full account the plans of intercity rail passenger service, local commuter rail services and the rail freight operators over a relatively long period of 20 years. The relatively independent plans of these various operators are synthesized into one long-range plan so that many incremental projects planned by each party over this 20-year period will collectively provide the infrastructure to permit the various services to coexist without degrading the various operations.

An initial reading of this document will quickly reveal that a Corridor Transportation Plan is a very detailed plan that will usually require relatively extensive research and analysis. Many people will ask why such a detailed plan is required at the beginning of a corridor project when there is so much “excess capacity” on the rail line in question. The observation concerning “excess capacity” is usually made by someone standing beside a rail line and observing that “I’ve seen only one train in the last two hours.” While similar observations may be true, most non-railroad people (and many lifelong railroaders) find it difficult to appreciate how train movements or routine maintenance activities many miles away cascade their impact up and down the railroad. Inevitably, a cursory analysis and operating plan for new or significantly upgraded corridor passenger service on an existing freight line (with or without commuter service) will result in undesirable or unacceptable reliability and/or performance levels for all corridor users. There is little question that providing the information and analysis to support a Corridor Transportation Plan may take a period of months, but in the long run its preparation is the quickest way to properly define all the elements that must be addressed in order to provide higher speeds and improved frequencies for intercity passenger service, while maintaining or improving freight and commuter services.

It has usually been found to be relatively easy to take a long range, 20-year plan and determine which pieces need to be done to support the initial service levels and which components can wait for future funding or service level needs. Conversely, without a detailed long-range plan, it is very difficult to know if the short-range plans and projects will address anything other than immediate problems. Sometimes, the apparent short-term solutions only make the long-term problems worse and will ultimately have to be removed and replaced—typically an expensive learning experience.

Proponents of a high-speed rail project also need to consider that any Federal funding or Federal approval of a new or upgraded intercity rail passenger corridor would require preparation of appropriate environmental documentation. Clearances have to be obtained

for a project under the requirements of the National Environmental Protection Act (NEPA) and the National Historical Preservation Act, section 4(f) of the DOT Act, the Clean Water Act, and others. All these acts require site-specific information (square footage of wetlands to be filled or detailed modifications to be made to an historic building, for instance) in order to prepare the documents and obtain approvals. A clear and complete understanding of all project elements, reached through sound engineering and railroad planning, is needed to complete these documents.

The Federal Railroad Administration has found that railroad corridor programs or projects lend themselves to tiered environmental documentation. Since funding design and construction of improvements to railroad corridors generally extends over decades, a tiered first level Environmental Impact Statement (EIS) or Programmatic Environmental Impact Statement (PEIS) is usually the appropriate form of documentation. This allows for identification of the full scope of projected improvements or modifications and either full analysis of defined elements or deferral of site-specific clearance of elements to later documentation. Typically, a long-range transportation plan is necessary to identify all project elements and for preparation of the initial environmental document. It is possible that the PEIS or first tier EIS may categorically exclude work that does not impact environmentally or historically sensitive resources (for example: installing welded rail, replacing ties, installing a new signal system, or reinstalling track on an old roadbed) and may also identify other elements for separate environmental documentation (such as: new stations, curve eliminations, new maintenance shops, and so forth). This type of documentation can incorporate by reference many elements of a corridor transportation plan and thus simplify the clearance process.

The balance of this document outlines parameters used and various factors that usually require analysis and study in preparing a corridor transportation plan. The document further discusses in some detail the analysis usually found to be the most critical to a transportation plan, but it should be emphasized that each corridor will most likely have unique conditions or circumstances that will have to be addressed individually. Additional information concerning these studies may be found in Chapter 17 of the American Railway Engineering and Maintenance Association manual of recommended practices.

## **II. Route Selection - Preliminary Analysis**

Potential rail transportation corridors will usually connect at least two and sometimes a series of relatively large population centers. A typical corridor may have one or several rail lines connecting the end points or various intermediate population centers. Where more than one rail line exists (or existed in the past), a determination must be made as to which route or combination of route segments will make up the corridor. Where multiple rail lines exist, it is frequently found that one or more are simply not compatible with being upgraded to corridor status, because of numerous curves, steep grades, routing that avoids population centers, routes that run down city streets at grade or other obvious untenable defects. A preliminary assessment of the options will usually reduce the possibilities to one or perhaps two viable routes that meet basic requirements for speed, multiple tracks,

intermodal station sites, ridership potential, estimated cost of improvements, and the like.

The selected route or routes will then need to be subjected to the comprehensive long-range analysis associated with a corridor transportation plan. The two most basic elements of any transportation plan are the selection of station sites and the preparation of passenger train schedules for the 20-year horizon plan.

#### A. Station Location Fundamentals

Projected ridership along a particular corridor is heavily influenced by accessibility of stations and the proposed train schedules. Station locations are subject to several sometimes conflicting demands, for example:

1. They must be readily accessible to where people live and work.
2. Too many stations will lengthen trip times excessively.
3. Too few stations will make it more difficult for riders to use the rail system.
4. Station sites need to cater to both business and leisure travel.

Building on American experience since the passage of the High-Speed Ground Transportation Act of 1965, as well as on successful examples abroad, the FRA has developed the following general guidelines for locating corridor rail passenger stations:

1. Each city should have a station located in or near the central business district. This is mandatory for larger Metropolitan Statistical Areas (MSAs), with metropolitan populations of 150,000 or more, since to do otherwise would undermine the inherent advantages of rail passenger systems. Central locations are highly desirable, if at all possible, for smaller cities as well. This center city station should have direct access to local transit systems (bus, rail, taxi, etc.) as well as appropriate amounts of parking for private cars.
2. One or more suburban stations need to be provided in the larger metropolitan areas with easy access to the local primary road system in order to accommodate potential riders living outside the city centers. Classic successful examples of suburban or beltway stations are Route 128 outside of Boston, MA and New Carrollton, MD outside of Washington, D.C. These "beltway"-type stations cater to automobile-oriented riders and thus need to have many hundreds, if



not several thousand, parking spaces to fulfill their role in corridor transportation.

3. Every effort should be made to have each corridor station serve as a regional intermodal passenger terminal for all forms of regional and local transportation systems.

Many cities, both large and small, were served at one time by more than one railroad, each with its own station. Some cities ultimately developed union stations, which brought two or more railroads under one roof and efficiently served a multiplicity of passenger train routings. Since the mid-20th century, however, these flexible infrastructures have been slowly vanishing under the pressures of urban development and reductions in the Nation's passenger train route-mileage. Because the restoration of adequate rail access, once lost, would cost the public far more than its preservation, planners need to devote special attention to identifying and protecting essential urban rail facilities. Thus, in addition to the passenger access parameters noted above, the following railroad operating characteristics need to be taken into account when evaluating and designing station sites for corridor applications.

1. Each station track configuration should provide for the through movement of trains along the corridor without having to reverse the train's direction at any time. Through stations are almost always preferable to stub-end terminals, both at the endpoints and intermediate points in a corridor.
2. Where interlockings are located at both ends of the station, the distance between the opposing home signals must be great enough to hold the longest anticipated passenger train (locomotives and cars), including long-distance trains that may operate over the corridor, without fouling either interlocking.
3. Where the normal movement of a corridor train requires a diverging movement through a turnout or crossover to access a platform, the turnout size should be as large as feasible given other local design parameters. Turnouts or crossovers should not be placed adjacent to a platform.
4. The length of a corridor platform should be as long as the longest anticipated passenger train, whether in corridor, long-distance, or commuter service, in order to avoid a very time-consuming double stop at the station and to allow maximum flexibility in train makeup.

5. In order to minimize station dwell time and comply with the Americans With Disabilities Act (ADA), the platform height should be equal to the car floor height. It is recognized that high-level platforms may, on a site-specific basis, entail facilities to protect freight operations (e.g., “gantlet” tracks).

## B. Scheduling Fundamentals

Preparing train schedules is unique to each corridor. The basic objective is to provide enough train service to attract sufficient riders to financially support the service without running an uneconomical number of train-miles. The following general train schedule guidelines have been developed from observations of corridor operations in this country and elsewhere:

1. Most riders do not like to take a train that departs before 6:00 a.m. or arrives at a station after midnight. In certain circumstances (e.g. on longer runs), passengers may be willing to arrive at destination somewhat after 12:00 midnight. Therefore, trains should not depart an originating station before 6:00 am or arrive after midnight unless an analysis has shown that it is more economical to deadhead equipment along the corridor to a common layover facility rather than to create another one at an intermediate point. Deadheading equipment (i.e., making a non-revenue move) along a corridor is not only operationally expensive (fuel, crew costs, maintenance costs, etc.), but it may also require additional mainline infrastructure (passing tracks, interlockings, etc.). Serious consideration should be given to establishing a mid-corridor layover facility (middle third of route), when a corridor exceeds 250-300 miles in length or when ridership patterns warrant, in order to provide reasonable early and late service to each end of a corridor.
2. In corridors of sufficient length (about 400 miles or more), a single overnight train in each direction not necessarily operating at high speed may be necessary to provide a complete service. Although such an overnight train may in itself be uneconomic, it will also attract passengers to daylight runs and could contribute to the overall viability of the corridor.
3. By definition, a corridor connects two or more large metropolitan areas. Train schedules should be arranged to maximize the accommodation of riders going to both ends of a corridor as well as

any intermediate points. This usually means that the first and last trains of the day make all stops along the corridor. It has been found that only the most heavily traveled corridors can economically justify express trains during the peak travel hours that skip the smaller intermediate stations. Where local commuter service is provided, intercity trains typically stop only at or near the end of the commuter zone as well as a beltway station.

4. It has been shown throughout the world that memory type schedules (trains leave a station at the same time past each hour) aid significantly in attracting and retaining riders. Therefore, whenever feasible, train schedules of all types should be based on the memory schedule principles.
5. Projected schedules for proposed corridor operations are typically prepared from computerized train performance calculators (TPC). These TPC systems simulate perfect train operations that almost never occur in the real world. All trains schedules prepared from TPC runs must have pads added to reflect real world operating conditions as outlined in section V(E) of this document.
6. Corridors usually follow the most direct route between two or more major population centers. Sometimes relatively large cities or a string of smaller cities may be located up to 100 miles to one side of the primary corridor. It may be beneficial to arrange for a spur off the main corridor to tap these markets and at the same time justify more frequent schedules on a portion of the main corridor than would otherwise be economically feasible. The spur(s) can be operated with connecting shuttle service or with a selection of trains from one of the corridor terminals or a combination of both options. As such spurs are complicating factors, the optimal service concept and corridor configuration can only be derived on a site-specific basis.

### **III. Physical Characteristics of the Rail Line (Existing and Proposed)**

The analysis required for a corridor transportation plan will necessitate assembling as much detailed information as possible about the rail line(s). Scaled drawings should be obtained or prepared which contain the following minimum information:

- A. Track plans showing
  1. Number and location of tracks (existing and previously removed)
  2. Curvature

- a. Degree of curve
  - b. Superelevation
  - c. Spiral length (spirals were not introduced in the U.S. until 1900, so most spirals are retrofitted onto old curves)
3. Track profiles showing all grades and grade change points
  4. Interlocking configurations including turnout and crossover sizes and/or diamond crossing with other rail lines
  5. Length of passing tracks, if any.
  6. Major bridges and tunnels including any weight or clearance restrictions, if any.
  7. Highway crossing locations and warning systems (public and private)
  8. Location of passenger stations and platforms
  9. Location of industrial spurs
  10. FRA track classification and construction
    - a. Rail weight and age, welded or jointed
    - b. Type of ties
    - c. Ballast type and section
  11. Standard turnout sizes in use
  12. Complex terminal and yard sites will typically require larger scales than open running main lines
  13. Location of right of way fencing
  14. Air rights ownership or utility rights of way
  15. Location of freight yards
- B. Signal system plans (the FRA regulations that require the enforcement of signal indications, when authorized speeds exceed 79 mph, means that improperly located signal positions or undesirable signal aspects, while overly

safe, may significantly add to the trip time of passenger trains under many circumstances).

1. Determine if the system is based on speed signaling or route signaling and obtain the relevant operating rules.
  2. Obtain or prepare a set of general signal plans (sometimes known as route and aspect charts) that shows each signal location and aspects that can be displayed (both wayside and cab signals).
  3. Determine the type of track circuits (AC, DC, coded, etc.)
  4. Determine if pole lines are used for signal lines
  5. Determine what the signal design speed is for each corridor segment for each type of train operated
  6. Obtain the train braking curves used with the signal design speed (freight and passenger)
  7. Highway crossing warning systems
    - a. Track circuit based
    - b. Overlay circuits
    - c. Constant warning time
  8. Location and type of hazard detectors (high/wide loads, dragging equipment, hot box, etc.) and their connection to the signal system.
  9. Interlocking snow melting systems
    - a. Type (electric, gas, hot air, etc.)
    - b. Remote or local control
- C. Communications systems along the corridor
1. Is it private or leased lines?
  2. Is there open line wire?
  3. Is the main system microwave, fiber optics, cable, or leased?
  4. Where are the radio transmitters for the wayside-to-train radio system?

What systems are used to reach the transmitters?

5. Is there any backup system ?

#### IV **Operations Support Facilities**

The rail line described in item III carries the trains that move along all or parts of a corridor; however, there are many other supporting facilities that may ultimately have to be modified, expanded, moved or eliminated as the corridor is upgraded to support more services operating at higher speeds. Narrative summaries of the following types of facilities need to be prepared (augmented with plans or drawings as necessary) in order to provide a long-term planning document.

- A. Passenger stations are critically important in attracting riders to intercity and commuter trains. The following information needs to be assembled for each existing and proposed station.
  1. Location in the community relative to work centers, homes and local highways
  2. Platform type (high or low level), length, width, access to station and if it is on tangent or curved track, "train approaching" warning devices, intertrack fences
  3. Length of platform canopy, if any
  4. Station size and amenities, staffed or unstaffed, primary use (commuter or intercity)
  5. Automobile parking capacity
  6. Intermodal access (bus, taxi, heavy or light rail transit)
  7. Existing physical condition
  8. Passenger information systems
  9. Compliance with the Americans with Disabilities Act
  
- B. Railway passenger vehicle storage and maintenance facilities will need to be provided at or near the various origination/destination points. The following information will need to be assembled:

1. Site of the facility
  2. Function of the facility (daily servicing and storage, light running repairs, medium repairs, etc.)
  3. Rail vehicle capacity
  4. Special facilities or equipment, if any (a wye or loop for turning trains, etc.)
  5. Existing physical condition
- C. The corridor rail line will require periodic inspection and repairs. The location of various maintenance-of-way bases, type of staff, required facilities, etc., needs to be documented; so that existing sites can be augmented or new ones selected.
- D. Each corridor will have one or more centers that control the movement of trains and equipment. The location of the traffic control centers needs to be identified, the type of equipment being used, and the capability of the systems to accept new track configurations and increased numbers of trains on the corridor.

#### **V. Proposed Operating Plan for All Corridor Services on a Date 20 Years in the Future**

It is essential for each organization intending to operate rail service of any kind over a corridor or portions of a corridor to analyze their long-term objectives and prepare a realistic assessment of the service levels that can be anticipated. Although each corridor will have unique projections, several general comments need to be made.

Copies of all operating agreements between the rail corridor owner and tenant operators with operating rights need to be obtained and appropriate summaries prepared so that everyone will know all of the various rights and conditions. Likewise, if the corridor contains moveable bridges over public navigable waterways, Coast Guard regulations covering those specific bridges should be obtained and summarized.

Very high annual growth rates (6 - 10%) are usually not sustained in a mature economy like that found in the United States, unless the particular corridor is shown to be experiencing large population and industrial growth or any proposed new services would tend to relieve existing overcrowding on alternative modes of travel. One might observe a relatively high growth rate for intermodal freight service, but when the diversion from more conventional carload freight is taken into account the overall growth is reduced rather significantly. Similarly, existing mature rail commuter systems around major cities like New York or Chicago might average 2% growth per year over 20 years, which in absolute terms would still require more and longer trains due to the high base ridership of existing service levels.

Conversely, a start-up commuter service in a relatively large metropolitan region might experience very high percentage growth rates, but still require only 30 minutes peak headways after 20 years. All projections need to be carefully scrutinized in order to avoid constructing infrastructure that may never be required.

Proposed schedules may be based on existing timetables if similar service now exists. However, most corridors will be projecting service of a kind not now in existence, which will require the use of computerized train performance calculators (TPCs) working on the data base developed in section III.

The following information needs to be developed for each service using the corridor:

- A. Intercity corridor passenger service
  - 1. Location of station stops
  - 2. Train schedules (include dwell time)
  - 3. Train size and type of equipment (coaches, tilt cars, food service, etc.), train weight and locomotive horsepower
- B. Local commuter services
  - 1. Location of station stops (existing and proposed)
  - 2. Train schedules (local, express, zone express, deadhead moves, etc.)
  - 3. Train consists (locomotives and cars), train weight and locomotive horsepower
  - 4. Branch line junction points
- C. Freight services
  - 1. Local freight schedules (note places where the train clears the corridor for extended periods of time)
  - 2. Manifest freight schedules (include all points where stops are made to pick-up or set-off cars and typical horsepower and tonnage)
  - 3. Intermodal freight schedules (include all stops, tonnage and typical horsepower/ton ratio)
  - 4. Mineral and extra train schedules (include all stops, tonnage and horsepower)



5. All yards or work sites should be defined
- D. Long distance passenger services
1. Location of station stops
  2. Train schedules (arrival and departure times at all stations)
  3. Train size, locomotive horsepower (minus hotel power requirements), type of cars (coach, sleeper, diner, mail, express, etc.)
- E. Schedule pad

Whenever passenger schedules are produced by various TPC runs, a pad must be added to the TPC schedule to account for a number of factors. The following describes various factors that need to be included for calculating a single-track schedule pad. A double-track schedule pad is the first term only (1.07T).

$$\textit{Schedule with pad} = 1.07T + M \left( \frac{1/2 L}{S} + W + \frac{D}{S} \right)$$

Where

T = Train performance calculator (TPC) run time

1.07 = 7% added for:

- a. Human operation instead of perfect TPC operation
- b. Some TPC assumptions will prove not feasible to achieve
- c. Extra station dwell for mail, baggage, wheelchairs, etc
- d. Temporary slow orders
- e. Low diesel power output or extra cars
- f. Congestion or other off-schedule trains
- g. Signal imposed delays
- h. Weather conditions
- i. Miscellaneous delays

M = Number of meets with other passenger trains (freight trains are assumed to wait longer for meets, and not cause delays to passenger trains)

L = Distance between passing tracks in miles (average with deviation not greater than 25%)

D = Distance in miles from home signal at passing track to distant signal at passing track.

S = Average speed in miles per minute

W = Interlocking operating time, use 1 minute

- a. 5 second loss of shunt protection
- b. 2 second CTC polling time for transmit/receive
- c. 8 second switch movement time for small interlocking (15 to 30 seconds for large interlocking)
- d. 30 second human response time
- e. 10 second train brake release time

Assumption: Passing tracks are at least 4 miles long with at least one intermediate block signal and turnouts are either equilateral #20 or lateral #20.

If freight traffic is particularly heavy on a single track railroad a further adjustment may be necessary to account for the occasion when a passing track between two passenger trains is occupied by a freight train, thus more than doubling the distance between passing tracks available for passenger trains. In order to keep the pad within reason, it may be necessary to provide a universal crossover in the middle of selected passing tracks so that a meet and overtake can occur at the same time. Alternatively, two passing tracks can be provided at the same location.

Railroads have historically placed most of the needed schedule pad near the end of the trip, in order to influence the on-time performance that is typically calculated from end point to end point. On long corridors with relatively large pads, this technique can result in relatively large deviations from published schedules near the end of a run. These large schedule deviations may be totally unacceptable to a high-density commuter operation, where certain schedule slots at junctions or major stations are reserved for the intercity corridor trains. Where high-density commuter or freight operations are encountered on a corridor, the intercity schedule pad must be spread out over the whole route at appropriate locations so that the intercity trains will have small schedule deviations at critical operating locations and not negatively impact the performance of other corridor users.

#### F. Trip time feasibility analysis

Analyzing a particular corridor to assess ways to increase average overall speeds will involve many TPC runs that individually determine the effects of changing one parameter at a time. All of the speed restrictions contained in the employees' timetable special instructions should first be carefully

reviewed to make sure everyone understands why they exist; sometimes their reason for existence is obsolete or is no longer valid. Most of the effort usually involves increasing speeds through curves, raising maximum speeds or increasing horsepower-per-ton ratios.

1. Increasing speeds through curves can be accomplished by increasing the actual superelevation up to a maximum of 6 inches, increasing the unbalance of passenger cars to approximately 5 inches for non-tilting vehicles, or by using tilt-body trains that can operate at an effective unbalance up to 9 inches as permitted by FRA regulations. Any increase in curve speeds must address the spiral curve which connects tangent track to a constant radius curve. Since spirals were not introduced to American railroads until 1900, the retrofitted spiral must be carefully checked to see if higher speeds can be accommodated with comfort and safety. Higher curve speeds will usually require rather significant changes to spirals, some of which will not prove feasible and will ultimately limit the maximum speed through a curve.
2. Maximum speeds on tangent track can typically be increased after the track structure has been improved and the track geometry (alignment, cross-level, profile, etc.) tightened up to meet FRA standards for the desired speed. Higher speeds may require respacing signals and installing cab signals for speeds above 79 mph. It should be noted that, when cab signals are installed, FRA regulations require all trains (freight, commuter, etc.) operating over those tracks to have fully functioning cab signals. Enforcement of all speed restrictions may be required where speeds exceed 110 mph. Highway grade crossings are prohibited where train speeds exceed 125 mph.
3. Increasing the horsepower-per-ton ratio by adding a locomotive on a typical corridor passenger train has been shown to improve low-speed acceleration and grade climbing speeds in addition to attaining higher maximum speeds. The improved lower-speed performance and grade climbing ability may eliminate the need for higher maximum speeds in order to attain a certain overall schedule.

## **VI. Proposed Railroad Operations Analysis**

Most railroad corridors being proposed for higher-speed, more frequent intercity passenger services will typically already have significant freight service over at least a significant portion of the route. Additionally, there is likely to be existing or proposed local commuter service in the larger metropolitan areas. Creating an infrastructure that will allow these three services to coexist on the same tracks is usually the biggest challenge in preparing a corridor transportation plan. Unless the corridor is short (100 miles or so) and service is made up of only commuter, intercity corridor, and local freight trains, it will be

necessary to employ a relatively sophisticated train operating model simulator that is smart enough to do its own train dispatching via alternative paths over the corridor's track configuration. At a minimum, these systems will need to be able to plot train movement stringlines at a useable scale (typically 10 minutes per inch), be able to randomly input delays by type of train (freight, commuter, intercity), and tabulate delays associated with each train operated during the 24 hour day. The plot should locate each interlocking or station and identify which track a train took as it moved over the corridor.

A typical corridor will probably require the model to be run a number of times, with track and interlocking changes being made after each run, before all services are able to operate at an acceptable level of 90% on-time performance. The initial schedules (developed under Section V) will have to be altered or additional infrastructure provided as conflict points are identified along the corridor. Conflicts will occur when a faster train has to pass a slower train (e.g., a non-stop intermodal freight overtaking a local commuter train) or opposing trains try to pass each other on a single track. It should be noted that schedule variability of freight trains is generally greater than that of passenger trains, because freight train tonnage and the resulting horsepower-per-ton ratios will vary rather significantly by day of week and through the various seasons of the year. After the modeling simulations and various revisions to track and schedules have produced what appears to be a viable operation for all services, it is desirable to run a 7-day simulation with only the random train performance changing daily to confirm that most normal operations can be handled.

## **CAUTION: FLEXIBILITY MUST BE MAINTAINED!**

The detailed railroad operations analysis described in these sections will provide useful, indeed indispensable, input to the design process. However, such an analysis can also instill, in those who perform it, an unjustified level of confidence in the infallibility and durability of the underlying assumptions and results. This overconfidence may, in turn, lead to the adoption of a facility design that will **only** function properly if all the study assumptions are fully realized.

In reality, actual operations almost **never** correspond with study assumptions:

- Because of the long gestation period for most transportation projects, many years may elapse between the projections and the real-world operations;
- Stations are added or deleted;
- Schedules are changed, and often augmented, to meet changes in public demand. For example, trains may be added over time, or memory schedules may be altered from hourly on the hour to hourly on the half-hour;
- Some improvements are never built, while other unforeseen project elements may be added;
- Structural changes in rail transportation may significantly alter the nature of one or more types of service over the territory in question (for example, new freight flows due to a merger of Class I railroads; or institution of a new commuter service).

Accordingly, no matter how careful and detailed is the operations analysis, **a proper design process will proactively and continually assure that the improved infrastructure is flexible enough to reliably accommodate a full spectrum of the potential changes—including but not limited to those exemplified above—that may affect all service types: intercity passenger, commuter and freight.**

The track configuration produced by the simulations should be reviewed to see if additional facilities should be added to handle routine contingencies such as; track maintenance,

locomotive or other train failure, etc. Complex terminal areas (passenger and freight) usually need detailed human analysis to insure that interlocking configurations provide for not only the routine revenue moves, but also the various switching and yard moves. After these adjustments are made, a scaled track plan of the entire corridor should be prepared and checked to insure that the proposed facilities can be built without undue expense. Some locations may require more detailed verification analysis using large-scale mapping (at 40 feet per inch) to confirm that the desired track layout will fit.

## **VII. Highway Crossings**

The typical corridor has a relatively large number of public and private highway-rail and pedestrian crossings at grade. A corridor transportation plan should identify each of these grade crossings, the relationship of the highway to the rail line at each site (sight lines, grades, pavement type, etc.), type of warning system, type and density of highway traffic, history of accidents, proximity of nearby crossings or grade separated bridges, etc. Special pre-emptive circuits should be considered for nearby highway traffic signals in order to clear highway traffic that might have stopped on a railroad grade crossing.

Every effort should be made to simply close as many highway grade crossings as possible, especially where there is a series of closely-spaced crossings or where nearby bridges can carry the traffic over or under the railroad. If closing a crossing is not readily feasible and train speeds will not exceed 110 mph, then each crossing should be provided with gates, flashing lights, and bells activated by a constant warning time system that adjusts for different train speeds. Four-quadrant crossing gates, lane barriers and other devices to preclude vehicles from driving around gates should be installed as deemed appropriate.

Every effort should be made to provide grade separation for high-density crossings or those with a history of accidents. Each of these sites usually requires a separate study to assess options.

## **VIII. Environmental/Historic Impacts**

A corridor transportation plan is not intended to be an environmental or historic assessment of any of the many proposed actions. However, there should be a general awareness of environmental or historic properties that could eventually pose major obstacles to proposed changes. A proposal to relocate a corridor on a causeway through a Federal or state waterfowl preserve for several miles might never see the light of day. Likewise, a proposal to demolish a station on the National Register of Historic Places would probably have extremely rough going. On the other hand, old signal towers have been relocated or demolished after preparing an Historic American Engineering Report to document the structure.

## **IX. Cost Estimates**

Conceptual level cost estimates should be prepared for each item listed as a corridor requirement. All parties should be aware that conceptual level cost estimates will carry a large contingency factor (typically 30 - 35 percent), because average unit costs are usually used and detailed design analysis has not been done. Review of the various cost estimates will typically result in some projects being deemed too expensive for the benefits produced, and requests to look at other alternatives will be made. It can be expected that a typical transportation plan will involve a number of options being costed before all parties can agree on some of the most cost-effective solutions.

A corridor transportation plan would typically summarize the various project costs into four basic categories:

- A. Recapitalization: This category would include repairs or replacement of life-expired capital assets that would be necessary under any circumstance to simply continue existing levels of service and operations. Typical elements might include:
  - 1. Bridge replacements (undergrade and overhead)
  - 2. Replacement of signal and communications cable
  - 3. Replacement of right-of-way fencing
  - 4. Replacement of station roofs, platforms, etc.
  
- B. Trip time improvements: This category would include items that are solely intended to reduce trip times for corridor passenger train service. Typical elements might include:
  - 1. Curve realignments
  - 2. Concrete ties and welded rail installation
  - 3. Grade crossing removal or improvements
  - 4. Install a new cab signal system in order to operate at more than 79 mph
  - 5. Reconfigure a junction or station for higher speeds
  - 6. Purchase higher-speed rolling stock

7. Install an electric traction system
- C. Capacity-related improvements: This category would include items that are required to increase the capacity of the corridor in order to allow increases in traffic by all users of the corridor. Typical elements might include:
1. New passing tracks
  2. Additional main tracks
  3. Interlocking reconfigurations
  4. Additional station platforms
  5. New or expanded maintenance facilities
  6. Install high-level ADA-compliant passenger platforms
  7. Revise signal locations and aspects
- D. Other projects: This category would include other corridor related projects that do not fall within any of the other three categories. Typical projects might include:
1. Purchasing new commuter rolling stock
  2. Building new commuter stations
  3. Constructing multi-modal terminals
  4. Constructing additional parking facilities
  5. Improving freight clearances

## **X. Prioritization of Projects**

A long-range plan that projects requirements over a period of two decades can only provide general guidance on construction priorities. The studies that make up a corridor transportation plan will usually be able to identify those projects that would be of significant benefit to existing operations or some projects that should have been built years ago. The studies will also identify projects that all parties agree will not be required until traffic levels have reached those projected near the end of the 20 year planning period. The remaining projects will fall into a rather broad category of being needed sometime in the next 5 to 15 years. Three priority categories are usually sufficient:

- A. Immediate requirement
- B. Mid-term requirement
- C. Long-term requirement

Many transportation executives will request a ranking of schedule improvement projects based on cost per minute saved. Comparison of several TPC runs would determine trip time savings achieved by curve alignment changes, higher maximum speeds, improved acceleration, higher-speed turnouts, etc., which can then be compared to the cost. Likewise, more frequent passing tracks on a single track railroad might be shown by the train modeling system to be able to reduce the schedule pad and thus the schedule at a certain cost per minute of eliminated pad.

## **XI. The Corridor Transportation Plan Report**

A formal report needs to be prepared that outlines and summarizes the analysis and findings of the various studies undertaken for the transportation plan. This typically results in a simple two volume report: Volume One summarizes the findings and projected costs of the various improvements; Volume Two contains the detailed analysis and justification of all the improvements contained in Volume One. Usage of past transportation plans has shown that Volume Two, with its detailed analyses and other technical components, is the more important from a substantive viewpoint. However, Volume One requires careful attention because it is directed toward policy-makers, who set priorities, control budgets, and need to understand the rationale for the proposals.

Volume One should contain information such as that described below. Since each corridor is unique, the topics, order, and emphasis will necessarily vary. The following arrangement has worked well in recent reports in which the FRA staff has participated.

- A. Executive Summary (extracted from the sections that follow)
- B. Chapter 1—Introduction
  - 1. Rationale for the study
  - 2. Purpose and approach
- C. Chapter 2—The Corridor Today
  - 1. Fixed Plant
    - a. Location (include map)
    - b. Background and ownership
    - c. Data sources for the condition descriptions that follow
    - d. Trackage and track conditions
      - (1) Rail
      - (2) Ties and timbers



- (3) Turnouts, crossovers, double-slip switches
      - (4) Ballast and subgrade
      - (5) Geometry of the permanent way; discuss line and surface; curves, spirals, and superelevation
    - e. Bridges, culverts, and other structures
    - f. Highway/railroad grade crossings
    - g. Electrification (if any)
    - h. Signals, train control, communications
      - (1) Signals and train control
      - (2) Operational control and dispatching
    - i. Support facilities (yards and shops; maintenance-of-way bases)
    - j. Stations and parking
  - 2. Users and services
    - a. Entities
    - b. Services
      - (1) Intercity passenger
        - (a) Corridor
        - (b) Other
      - (2) Commuter (there may be more than one type)
      - (3) Freight (Through and local; there may be multiple types)
      - (4) Summary description of existing service quality
- D. Chapter 3—Service Goals (i.e. what each service expects or intends by the planning “horizon year,” which should be identified early in this chapter.)
  - 1. Intercity passenger
    - (a) Corridor
    - (b) Other
  - 2. Commuter (there may be more than one type)
  - 3. Freight (Through and local; there may be multiple types)
- E. Chapter 4—Methodologies (i.e., how the work was done; the chapter should largely track this guidance manual. Topics for additional study can be listed here as well.)
- F. Chapter 5—Analytical results (Generalized descriptions; site-specific projects go in Chapter 8)
  - 1. Travel time analyses (train performance calculator results and discussion)
  - 2. Capacity analyses (manual and computerized train interaction simulations)
- G. Chapter 6—Environmental/historic factors. Summarize any items that have surfaced in the study that appear to warrant any environmental/historic reviews.
- H. Chapter 7—Corridor-wide investments. (i.e., investments in subsystems. For

each of the components, exemplified by the following, “the need” (based on foregoing chapters) should be summarized and “the program” should be described.)

1. Track geometry (curves, spirals, superelevation)
  2. Track structure (ordinary track components and special trackwork)
  3. Bridges, culverts, and other structures
  4. Highway-railroad crossings (general treatments; specific major projects go in Chapter 8)
  5. Electrification (if applicable)
  6. Signals and train control
  7. Support facilities
  8. Stations and parking
- I. Chapter 8—Site-Specific Investments. (This key chapter should describe, both in words and in very clear before-and-after schematics, all important site-specific improvements and rationalizations.)
- J. Chapter 9—Program summary and conclusions. This chapter should recapitulate the potential improvements, summarize the study’s conclusions, and provide a table of corridor-wide and site-specific investment proposals, with their estimated costs.

The detailed appendices in Volume Two should contain the following minimum information:

- A. The final proposed operating schedules of all trains (including deadheads) of all users of the corridor (intercity passenger, commuter, freight, and long-distance passenger services), including the ultimate destination or origination of each train.
- B. The final track configuration of the entire corridor drawn to scale (sample attached as Exhibit 1) and containing the following basic information:
1. All main tracks, passing tracks, industrial spurs, station tracks, etc.
  2. All interlockings and junctions with other lines showing turnout sizes and track configuration
  3. The location of all passenger platforms
  4. The location of all pedestrian and highway grade crossings:
    - a. To be removed
    - b. To be grade separated
    - c. To remain in use

5. All maintenance facilities and yards
  6. All curves, major bridges and tunnels
  7. All industrial freight spurs
- C. Cost estimates of distinguishable segments such as a passing track (turnouts, signals, track components, bridges, retaining walls, earthworks, etc.). Listings of unit cost figures used in the estimates should be included.
  - D. The detailed analysis of each curve on the corridor showing elements such as: degree of curve, superelevation, spiral length, maximum speed if limited by jerk rate (the rate of change of superelevation), etc.
  - E. A detailed description explaining the train operating modeling work that describes the justification for each of the changes recommended for the corridor track configuration.
  - F. The final proposed speed-versus- distance plot for the proposed intercity corridor passenger service and a brief description of the proposed passenger trains (horsepower, tonnage, seats, maximum speed, tilt or non-tilt, etc.)
  - G. A discussion of interactions between various individual projects that may dictate the construction sequence or cause significant disruption to train operations. Some projects, such as replacing a major bridge or interlocking, may require suspending all rail service for a period of time (several days to a week or two) during which other work can be accomplished without additional disruption.
  - H. A detailed description of proposed signal system changes such as; installing cab signals, respacing signal locations for higher speeds, adding signal aspects to increase capacity, installing a new centralized traffic control system, etc. This section should contain a description of any vehicle modifications required to permit operations on a new cab signal or speed enforcement system.

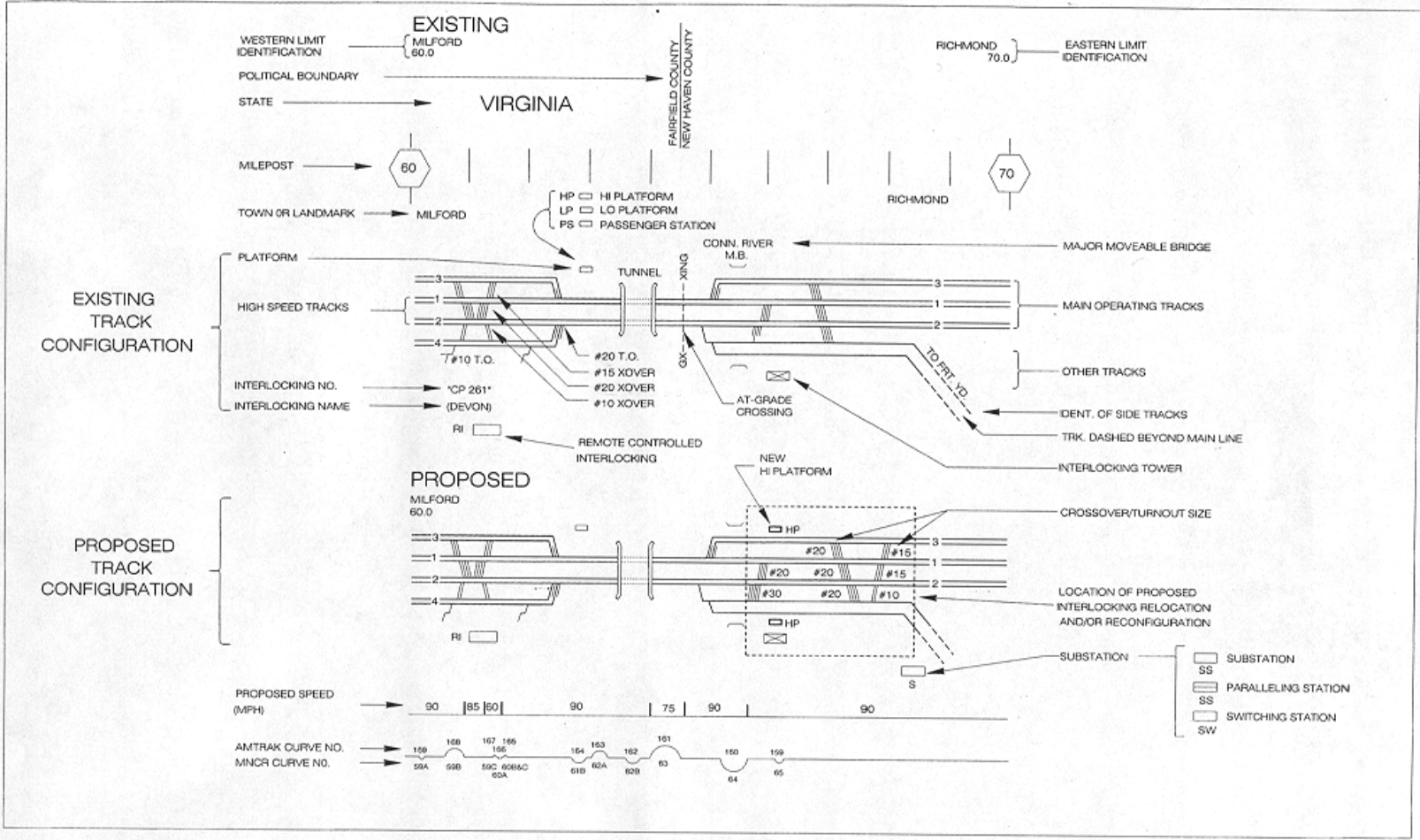

SCALE IN MILES  
0 1 2 3  
De LEUW, CATHER

EXHIBIT 1  
TRACK CONFIGURATION LEGEND

D:\DATA\0a\Corridor Planning Revised 07-08-05.doc

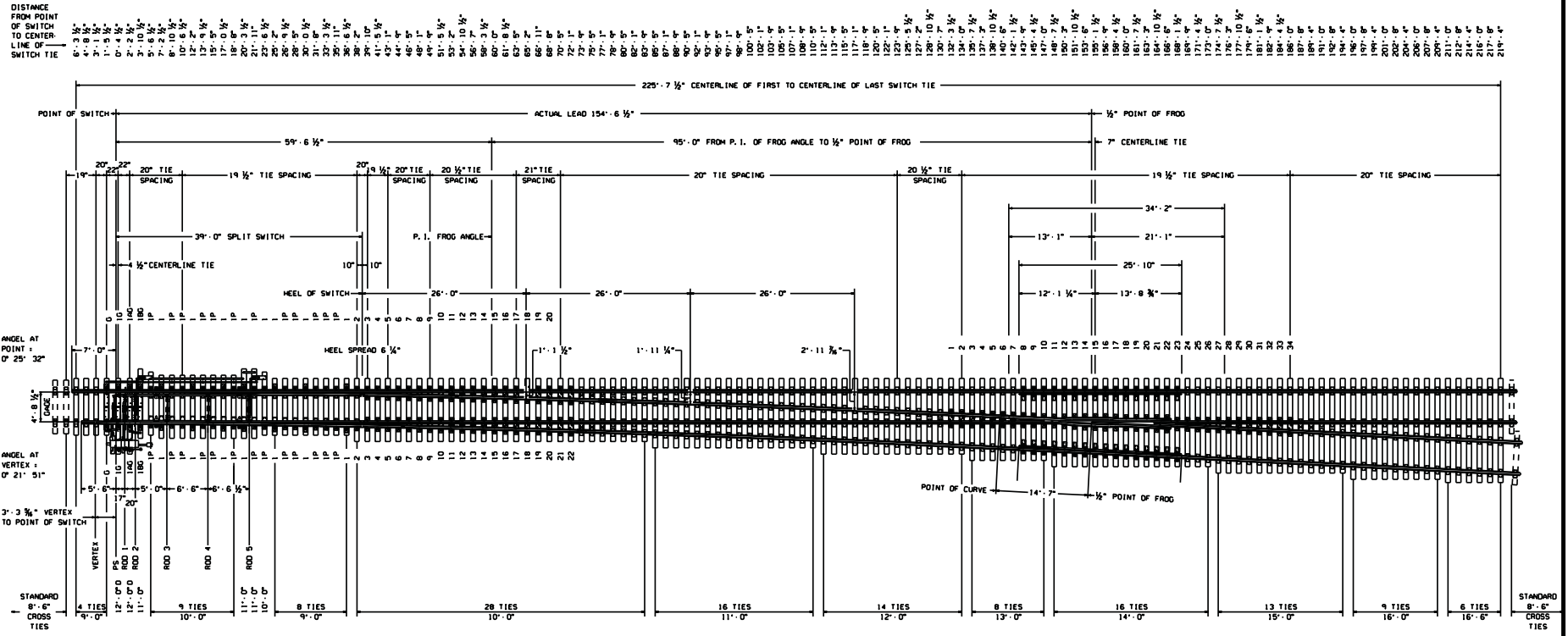

PLAN OF RIGHT HAND TURNOUT

WORKMANSHIP AND MATERIALS SHALL BE PER CURRENT AREA SPECIFICATIONS UNLESS OTHERWISE SPECIFIED.

SINCE THE ALLOWABLE VARIATION IN STANDARD LENGTHS OF RAILS, FROGS AND SWITCH POINTS IS GREATER THAN THE NORMAL EXPANSION GAPS AT RAIL JOINTS AND THICKNESS OF INSULATING END POST IN INSULATED JOINTS, NO ALLOWANCE HAS BEEN MADE FOR FOR EXPANSION GAPS AND INSULATING END POSTS IN COMPUTING LENGTHS OF RAIL SHOWN.

USE 39'-0" CURVED SPLIT SWITCH WITH UNIFORM RISERS PER DRAWINGS 2305, 2312, AND 2313.

SEE DRAWING 2309 FOR STRAIGHT AND CURVED CLOSURE RAILS, AND STRAIGHT AND CURVED LEAD RAILS.

SWITCH HAS ADJUSTABLE PANOROL BRACES PER DRAWING 2317.

FROG USES MILLED SEAT AND FLAT PLATES WITH WELDED PANOROL SHOULDER PER DRAWING 2407.

ALL TIES TO WHICH AN ANCHOR CAN BE APPLIED WILL BE BOX ANCHORED ON BOTH THE THROUGH TRACK AND DIVERGING TRACK, AND FOR A DISTANCE OF 234 FEET IN EACH DIRECTION. DO NOT PLACE ANCHORS WHERE THEY MAY INTERFERE WITH MOVING PARTS. EXCEPTION: RAIL ANCHORS ARE NOT USED IF PANOROL TIE PLATES ARE INSTALLED.

THE FOUR SWITCH POINT ROLLERS ARE TO BE FURNISHED BY TRAIN CONTROL.

THE NUMBER OF INSULATED JOINTS REQUIRED DEPENDS ON TURNOUT LOCATION.

LEAD RAIL WILL NOT BE FURNISHED FOR TURNOUTS TO BE INSTALLED BY PROGRAM RAIL GANDS LAYING NEW RAIL.

SWITCH PLATE AND TIE LAYOUT ARRANGED FOR POWER THROW MECHANISM PER TRAIN CONTROL STANDARDS.

TURNOUT DATA	
NUMBER	20
ANGLE	2°-51'-51"
TOTAL LENGTH	341'-2"
TIE LENGTH	13'-1"
HEEL LENGTH	21'-1"
TIE SPREAD	7 3/8"
LENGTH OF SWITCH POINT	25'-0"
HEEL SPREAD	6 1/2"
HEEL ANGLE	1°-06'-17"
THICKNESS OF POINT	9'-0"
ANGLE AT POINT	0°-25'-32"
RADIUS	3291.6863'
VERTEX DISTANCE	0"
THICKNESS OF POINT	1/2"
ANGLE AT POINT	0°-21'-51"
RADIUS OF STOCK RAIL	3015.1060'
VERTEX DISTANCE	3'-3 3/8"
ACTUAL LEAD	154'-6 1/2"
RADIUS OF CENTERLINE	3289.3321'
ANGLE AT POINT	1°-44'-31"
STRAIGHT CLOSURE LENGTH	102'-5 1/2"
CURVED CLOSURE LENGTH	102'-6 1/2"
P. C. TO 1/2" POINT OF FROG	14'-7"

BILL OF TRACK MATERIAL	
QUANTITY	DESCRIPTION
1	NO. 20 RAILBOUND MANGANESE STEEL FROG, COMPLETE, PER DRAWING 2407.
2	GUARD RAILS, ADJUSTABLE, 25'-10", COMPLETE, PER DRAWING 2412.
1	59'-6" STRAIGHT STOCK RAIL PER DRAWING 2309.
1	51'-0" BENT & CURVED STOCK RAIL PER DRAWING 2309.
1	39'-0" CURVED SPLIT SWITCH, COMPLETE, WITH UNIFORM RISERS, PER DRAWINGS 2305, 2309, 2312, 2313, 2314, 2316, & 2317.
1	39'-0" RAIL W/ INSULATED JT. 24'-0". 15'-0" O'LEGS
1	39'-0" RAIL W/ INSULATED JT. 29'-0". 10'-0" O'LEGS
400	FEET OF WELDED RAIL
16	JOINTS, COMPLETE
2 DR 4	INSULATED JOINTS AT SWITCH POINT OR CLEARANCE.
6	TIE PLATES - MINIMUM
0	300
0	KEGS, TRACK SPIKES, 100 POUND KEGS.
0	24
12	KEGS, TRACK SPIKES, 100 POUND KEGS.
850	RAIL ANCHORS
472	SCREW SPIKES.
228	PANOROL CLIPS, REGULAR.

**CSX** TRANSPORTATION  
**NUMBER 20 TURNOUT AND CROSSOVER  
 RAILBOUND MANGANESE FROG  
 FOR 122CB, 132RE, AND 136RE RAIL**

SIGNED	SIGNED
REVIEWED - DIRECTOR, STANDARDS AND TESTING	APPROVED - ASSISTANT VICE PRESIDENT, EQUIPMENT AND TRACK SYSTEMS ENGINEERING
ISSUED, AUGUST 29, 1997	REVISED, MAY 29, 1998

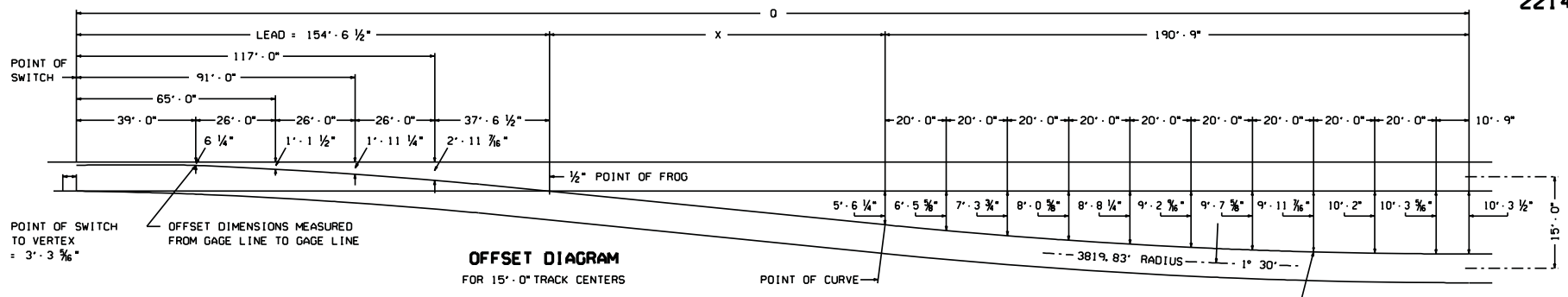

**OFFSET DIAGRAM**  
FOR 15' 0" TRACK CENTERS

OFFSET DIMENSIONS MEASURED FROM GAGE LINE TO GAGE LINE. FOR TRACK CENTERS OTHER THAN 15' 0", INCREASE OR DECREASE OFFSET DIMENSIONS BY SAME AMOUNT THAT TRACK CENTERS ARE INCREASED OR DECREASED FROM 15' 0", AND ADJUST "X" DISTANCE.

CROSSOVER DATA		
TRACK CENTERS	DISTANCE BETWEEN 1/2" POINTS OF FROGS	
	MAIN TRACK	CROSSOVER
15' 0"	109' 9 3/4"	110' 2 1/4"
14' 0"	89' 9 3/4"	90' 2 1/8"
1.0" CHANGE	19' 11 7/8"	20' 0 1/8"
1" 0" CHANGE	19.988"	20.013"

TRACK CENTERS	CURVE DATA	
	DIMENSION	
	O	X
13' 0"	414' 10 1/2"	69' 6 3/8"
14' 0"	434' 10 1/2"	89' 6 3/8"
15' 0"	454' 10 1/2"	109' 6 3/8"
16' 0"	474' 10 1/2"	129' 6 3/8"
1.0" CHANGE	19.988"	19.988"

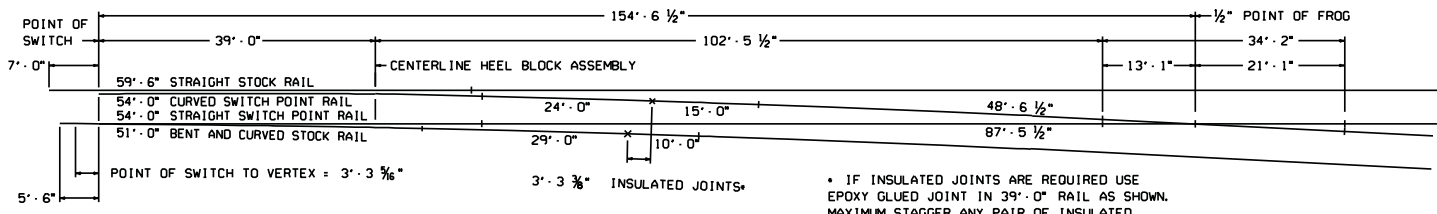

**RAIL LAYOUT DIAGRAM**

\* IF INSULATED JOINTS ARE REQUIRED USE EPOXY GLUED JOINT IN 39' 0" RAIL AS SHOWN. MAXIMUM STAGGER ANY PAIR OF INSULATED JOINTS IS 4' 6".

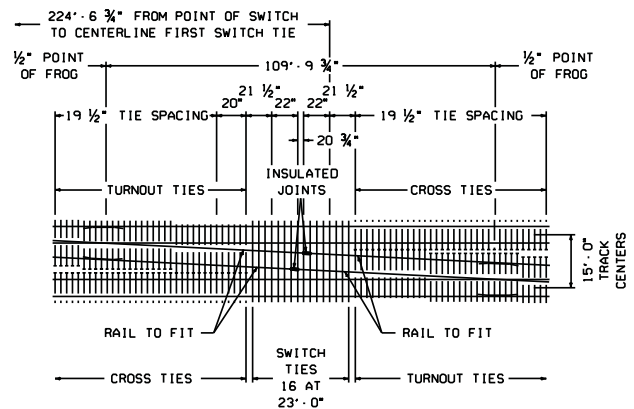

**CROSSOVER - 15' 0" TRACK CENTERS**

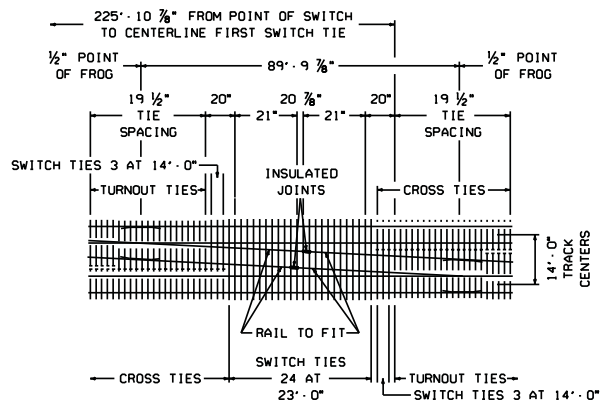

**CROSSOVER - 14' 0" TRACK CENTERS**



**NUMBER 20 OFFSET AND LAYOUT DIAGRAMS FOR 122CB, 132RE, AND 136E RAIL**

REVIEWED - DIRECTOR, STANDARDS AND TESTING	SIGNED	APPROVED - ASSISTANT VICE PRESIDENT, EQUIPMENT AND TRACK SYSTEMS ENGINEERING	SIGNED
ISSUED, AUGUST 29, 1997		REVISED, MAY 29, 1998	





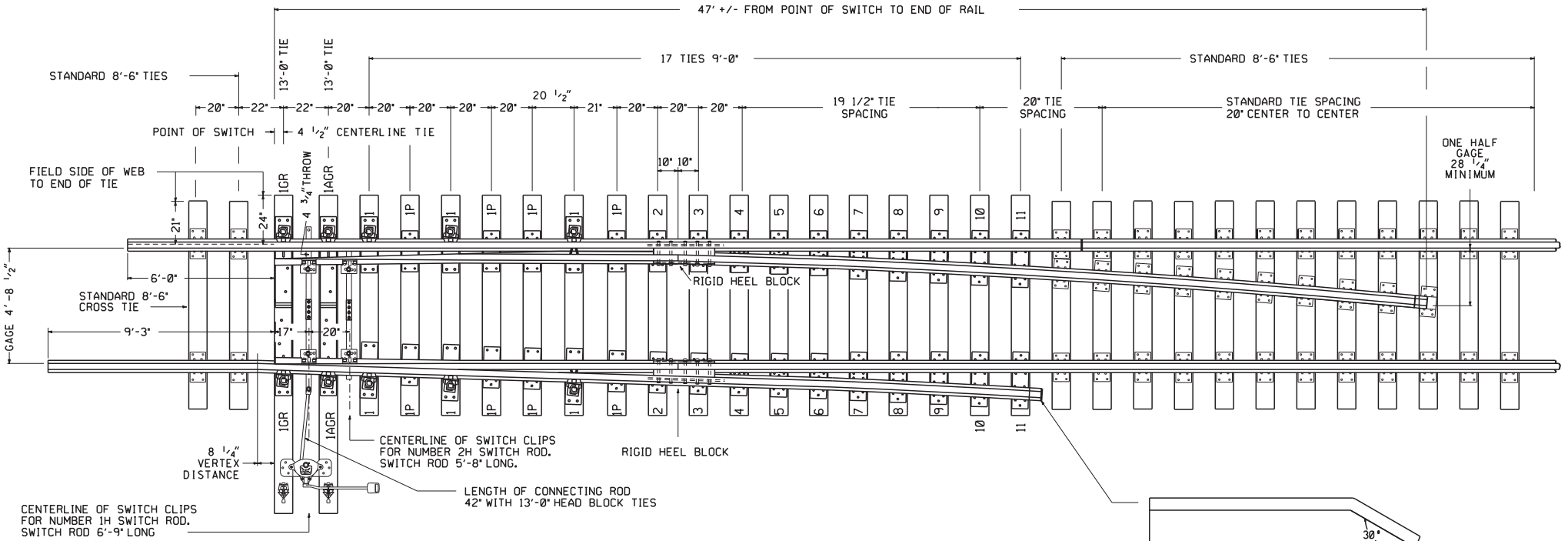

PLAN OF RIGHT HAND DERAIL LAYOUT

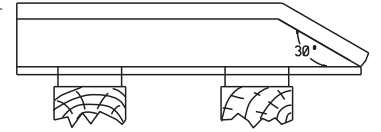

END OF RAIL CHAMFER DETAIL  
(TYPICAL FOR BOTH RAILS)

SWITCH POINT PER STANDARD PLAN 2301.  
 STOCK RAIL PER STANDARD PLAN 2306.  
 SWITCH PLATES PER STANDARD PLANS 2310 AND 2311.  
 MAIN TRACK TIES MAY BE USED IN PLACE OF SWITCH TIES WHEN THE DERAIL IS INSTALLED IN OTHER THAN A MAIN TRACK.  
 FOR MACHINE OPERATED DERAIL, USE A 9'-0" SWITCH TIE AHEAD OF SWITCH POINT AND DAPPED HEAD BLOCK TIES PER SIGNAL STANDARDS.  
 FOR MACHINE OPERATED DERAIL, USE 0G, IGR (OR IGL), AND IAGR (OR IAGL) GAGE PLATES INSTEAD OF TIE PLATES AND GAGE PLATES IGR AND IAGR.



16'-6" DOUBLE SWITCH POINT DERAIL

*Harold Okun*

APPROVED - DIRECTOR  
ENGINEERING STANDARDS

*M.E. McMaster*

APPROVED - ASSISTANT VICE  
PRESIDENT ENGINEERING

PREPARED BY:  
M.E. AUSTIN

ISSUED: OCTOBER 31, 2000  
REVISED: NOVEMBER 07, 2012

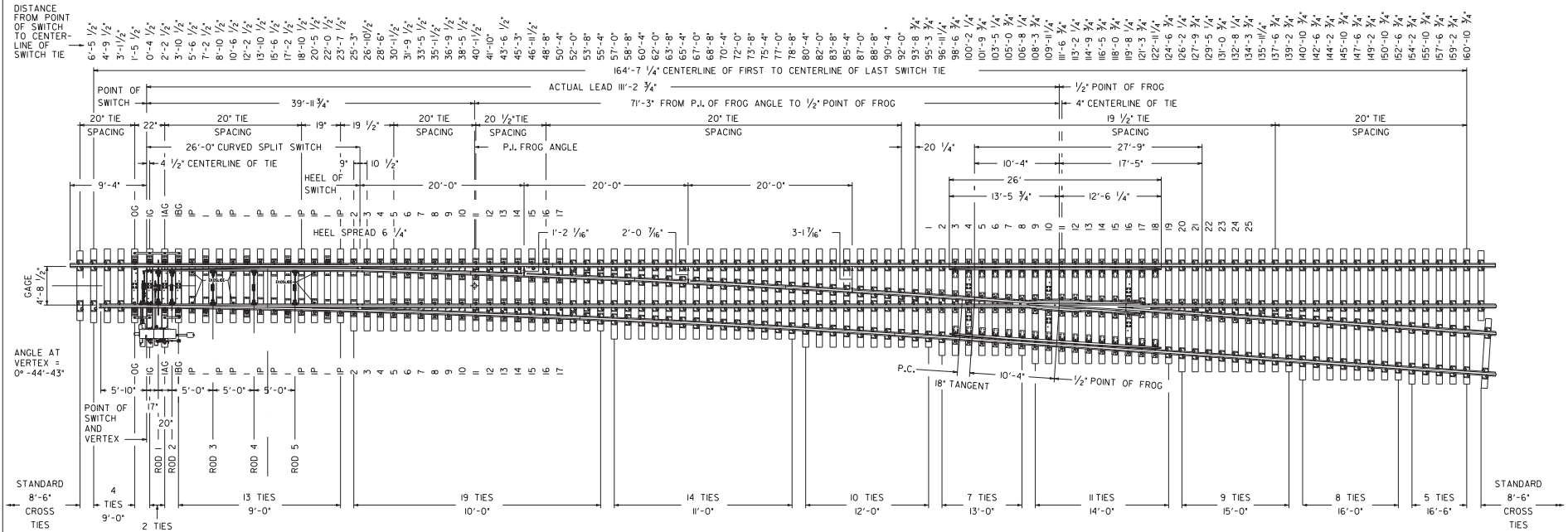

PLAN OF RIGHT HAND TURNOUT

WORKMANSHIP AND MATERIALS SHALL BE PER CURRENT AREMA SPECIFICATIONS UNLESS OTHERWISE SPECIFIED. SINCE THE ALLOWABLE VARIATION IN STANDARD LENGTHS OF RAILS, FROGS AND SWITCH POINTS IS GREATER THAN THE NORMAL EXPANSION GAPS AT RAIL JOINTS AND THICKNESS OF INSULATING END POST IN INSULATED JOINTS, NO ALLOWANCE HAS BEEN MADE FOR EXPANSION GAPS AND INSULATION END POSTS IN COMPUTING LENGTHS OF RAIL SHOWN.

USE 26'-0" CURVED SPLIT SWITCH WITH UNIFORM RISERS PER DRAWING 2321.

SEE DRAWING 2218 FOR STRAIGHT AND CURVED CLOSURE RAILS, AND STRAIGHT AND CURVED LEAD RAILS. MANUFACTURER SHALL VERIFY ALL DIMENSIONS BEFORE FABRICATION.

SWITCH HAS ADJUSTABLE BOLTLESS BRACES, PREFERRED SWITCH BRACE IS PRS CLAMPTITE. ALTERNATE IS BETHLEHEM BOLTLESS.

FROG USES MILLED SEAT AND FLAT PLATES WITH WELDED PANDROL SHOULDERS PER DRAWING 2415.

EVERY TIE WILL BE BOX ANCHORED FOR A DISTANCE OF 234 FEET AHEAD OF THE SWITCH POINT, AND EVERY TIE ON BOTH TRACKS WILL BE BOX ANCHORED FOR A DISTANCE OF 234 FEET BEYOND THE JOINT OR WELD AT THE HEEL OF FROG.

THE NUMBER OF INSULATED JOINTS REQUIRED DEPENDS ON TURNOUT LOCATION.

USE 6-1/2" COMMON STANDARD SCREWS ON ALL PLATES 3/4" THICK OR MORE. OTHERWISE USE 6" SCREW SPIKES. SWITCH PLATE AND THE LAYOUT ARRANGED FOR POWER THROW MECHANISM PER TRAIN CONTROL STANDARDS. ALL FROG PLATES TO BE MILLED SEAT 3/4" UNDER RAIL BASE

ORDERING INFORMATION		
CLASS	ITEM	DESCRIPTION
10	6650300	TURNOUT PANELED RH 136RE ON WOOD TIES NO 15 W/RBM FROG PER CSX DWG 2217 & 2218
10	6650310	TURNOUT PANELED LH 136RE ON WOOD TIES NO 15 W/RBM FROG PER CSX DWG 2217 & 2218

BILL OF TRACK MATERIAL		
QUANTITY	DESCRIPTION	
1	NO.15 RAILBOUND MANGANESE STEEL FROG, COMPLETE, PER DWG. 2415 BONDED FOR SIGNALS	
2	GUARD RAILS, COMPLETE, (26' ADJUSTABLE)	
1	58"-10" STRAIGHT STOCK RAIL PER DRAWING 2322	
1	58"-8" BENT STOCK RAIL PER DRAWING 2322	
1	38"-5" RAIL W/PREMIUM INSULATED JT.10'-0"-28'-5" LEGS	
1	38"-5" RAIL W/PREMIUM INSULATED JT.20'-0"-18'-5" LEGS	
1	STRAIGHT CLOSURE RAIL: 61'-4 3/4"	
1	CURVED CLOSURE RAIL: 23'-1"	
260	FEET OF PREMIUM WELDED RAIL	
1	26'-0" CURVED SPLIT SWITCH, COMPLETE, WITH UNIFORM RISERS, PER DWGS. 2321, 2322, 2323 2324, 2325, AND 2326	
1	FRONT ROD ASSEMBLY PER SS001 AND SS044	
12	JOINTS, COMPLETE INCL. J CLIPS AND BOLTS	
6	INSULATED JOINTS, COMPLETE INC. E2063B CLIPS	
1300	SCREW SPIKES 6 1/2" LONG OR 7 1/2" LONG EVERGRIP SPIKES	
3	KEG TRACK SPIKES	
196	PANDROL TIE PLATES	
659	PANDROL CLIPS, REGULAR	
1	PANDROL CLIP, LEFT HAND	

TURNOUT DATA	
NUMBER	15
ANGLE	3°-49'-06"
TOTAL LENGTH	27'-9"
TOE LENGTH	10'-4"
HEEL LENGTH	17'-5"
TOE SPREAD	7 3/4"
HEEL SPREAD	14 7/8"
LENGTH OF SWITCH POINT	26'-0"
HEEL SPREAD	6 1/4"
HEEL ANGLE	1°-32'-57"
THICKNESS OF POINT	0"
ANGLE AT POINT	0°-44'-47"
RADIUS	1,855.769'
VERTEX DISTANCE	9'-0"
THICKNESS OF POINT	0"
ANGLE AT POINT	0°-44'-43"
RADIUS	1,851.061'
VERTEX DISTANCE	0"
ACTUAL LEAD	III'-2 3/4"
RADIUS OF CENTERLINE	1,853.415'
DEGREE OF CURVE	3°-03'-30"
CENTRAL ANGLE - SWITCH	0°-48'-10"
CENTRAL ANGLE - CLOSURE	2°-16'-09"
CENTRAL ANGLE - TOTAL	3°-04'-19"
STRAIGHT CLOSURE LENGTH	74'-10 3/4"
CURVED CLOSURE LENGTH	75'-0"
TANGENT ADJACENT TOE OF FROG	18'

BILL OF SWITCH TIES			
LENGTH	TURNOUT ONLY	CROSSOVER	
		14'-0"	15'-0"
9'-0"	17	34	34
10'-0"	19	38	38
11'-0"	14	28	28
12'-0"	10	20	20
12'-0" (Dapped)	2	4	4
13'-0"	7	14	14
14'-0"	11	22	22
15'-0"	9	0	18
16'-0"	8	0	0
16'-6"	5	0	0
23'-0"	0	20	15
TOTAL NO.	102	184	196
BOARD MEAS.	6,458J	11,997.5	12,517.3



NO. 15 TURNOUT AND CROSSOVER WITH 26'-0" CURVED SWITCH POINTS FOR 136RE RAIL

*Legend Okun*  
APPROVED - DIRECTOR  
ENGINEERING STANDARDS

*M.E. Austin*  
APPROVED - ASSISTANT VICE  
PRESIDENT ENGINEERING

PREPARED BY,  
M.E. AUSTIN

ISSUED: MARCH 01, 2000  
REVISED: DECEMBER 23, 2011

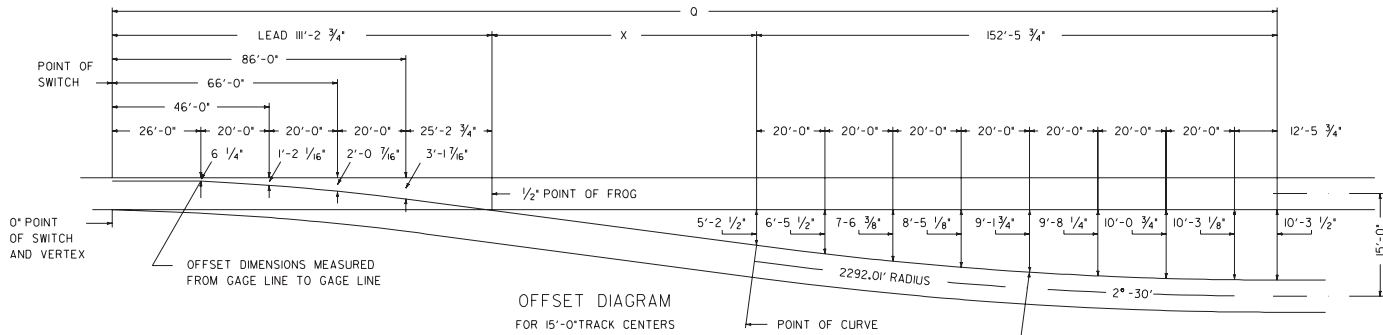

TRACK CENTERS	CROSSOVER DATA	
	DISTANCE BETWEEN 1/2 POINTS OF FROGS	
	MAIN TRACK	CROSSOVER
15'-0"	82'-3"	82'-8 3/32"
14'-0"	67'-3 3/16"	67'-8 29/32"
1'-0" CHANGE	14'-11 13/16"	15'-0 3/16"
1" CHANGE	14.9844"	15.0156"

TRACK CENTERS	CURVE DATA	
	DIMENSION	
	O	X
13'-0"	311'-2"	47'-5 1/2"
14'-0"	326'-1 3/4"	62'-5 1/4"
15'-0"	341'-1 3/8"	77'-5 1/8"
16'-0"	356'-1 1/8"	92'-4 7/8"
1.0" CHANGE	14.9844"	14.9844"

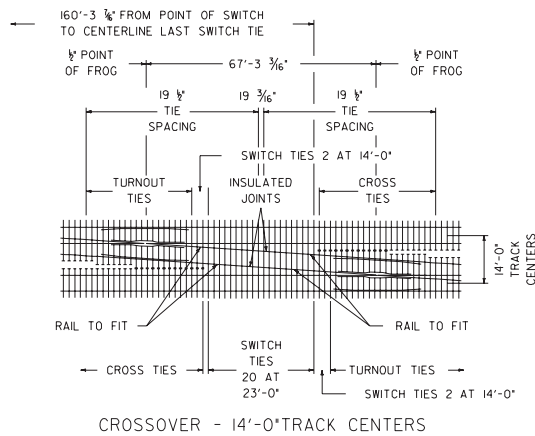
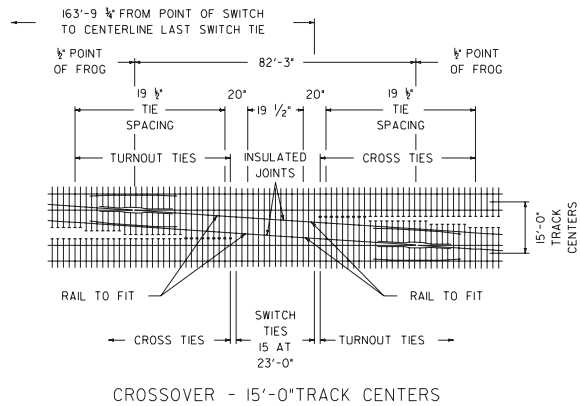
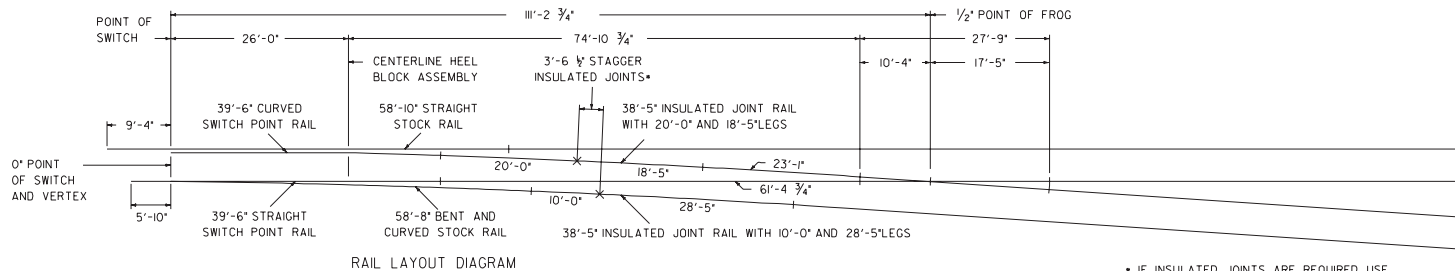

**CSX** TRANSPORTATION

NUMBER 15 OFFSET AND LAYOUT DIAGRAMS FOR I36RE RAIL

APPROVED - DIRECTOR  
ENGINEERING STANDARDS

APPROVED - ASSISTANT VICE  
PRESIDENT ENGINEERING

PREPARED BY,  
M.E. AUSTIN

ISSUED: MARCH 01, 2000  
REVISED: DECEMBER 23, 2011

11/16" ADDED FRONT ROD ASSEMBLY

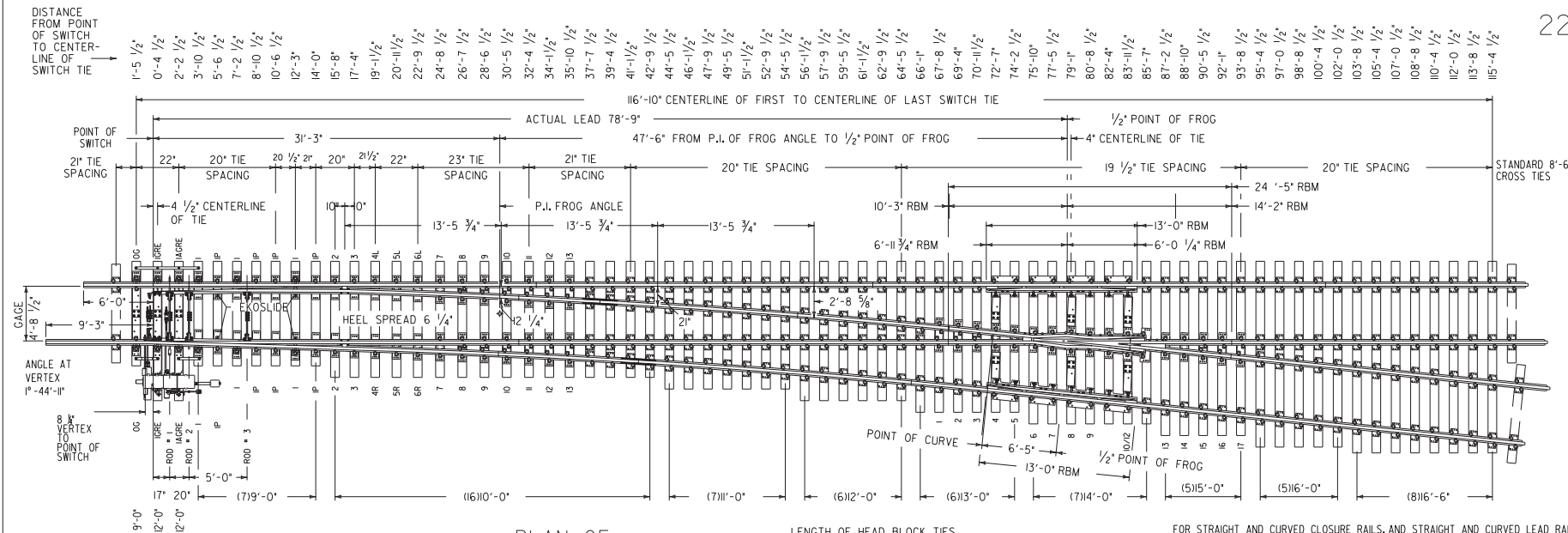

PLAN OF RIGHT HAND TURNOUT

SWITCH PLATE AND TIE LAYOUT ARRANGED FOR POWER THROW MECHANISM PER SIGNAL SECTION DRAWING NO. S5001

LENGTH OF HEAD BLOCK TIES  
 13'-0" FOR HAND OPERATED  
 14'-0" FOR HAND OPERATED WITH CIRCUIT CONTROLLER  
 12'-0" FOR MACHINE OPERATED  
 16'-0" FOR SPRING SWITCH  
 VERTICAL SWITCH RODS SHOWN

FOR STRAIGHT AND CURVED CLOSURE RAILS, AND STRAIGHT AND CURVED LEAD RAILS, SEE DRAWING 2225.  
 SWITCH HAS ADJUSTABLE BOLTLESS BRACES. PREFERRED SWITCH BRACE IS PRS CLAMP TIE. ALTERNATE IS BETHLEHEM BOLTLESS.  
 RBM FROG USES MILLED SEAT PLATES WITH WELDED PANDROL SHOULDERS PER DRAWING 2431.  
 ON PLATES WHERE THERE ARE 3 ADJACENT ROUND HOLES, THE CENTER HOLE IS RESERVED FOR FUTURE MAINTENANCE.  
 RAIL ANCHORS ARE NOT TO BE USED IF PANDROL TIE PLATES ARE INSTALLED.

IF PANDROL PLATES ARE NOT USED, ALL TIES IN THE TURNOUT TO WHICH AN ANCHOR CAN BE APPLIED WILL BE BOX ANCHORED ON BOTH THE THROUGH TRACK AND DIVERGING TRACK. EVERY TIE WILL BE BOXED ANCHORED FOR A DISTANCE OF 130 TIES AHEAD OF THE SWITCH POINT, EVERY TIE ON BOTH TRACKS WILL BE BOX ANCHORED FOR A DISTANCE OF 130 TIES BEYOND THE END OF SWITCH TIES ON THE FROG END OF TURNOUT. DO NOT PLACE ANCHORS WHERE THEY MAY INTERFERE WITH MOVING PARTS.

ALL FROG PLATES TO BE MILLED SEAT 1" THICK 1/4" MILLED

WORKMANSHIP AND MATERIALS SHALL BE PER CURRENT AREMA SPECIFICATIONS UNLESS OTHERWISE SPECIFIED.

SINCE THE ALLOWABLE VARIATION IN STANDARD LENGTHS OF RAILS, FROGS AND SWITCH POINTS IS GREATER THAN THE NORMAL EXPANSION GAPS AT RAIL JOINTS AND THICKNESS OF FIBRE END POST IN INSULATED JOINTS, NO ALLOWANCE HAS BEEN MADE FOR EXPANSION GAPS AND FIBRE END POSTS IN COMPUTING LENGTHS OF RAIL SHOWN.



NUMBER 10 TURNOUT AND CROSSOVER  
 RAILBOUND MANGANESE FROG FOR 136RE RAIL

*Legend O'Neil*      *M. E. Austin*  
 APPROVED - DIRECTOR      APPROVED - ASSISTANT VICE  
 ENGINEERING STANDARDS      PRESIDENT ENGINEERING

PREPARED BY, M.E. AUSTIN      ISSUED: APRIL 17, 2001  
 REVISED: DECEMBER 23, 2011

BILL OF SWITCH TIES			
LENGTH	TURNOUT ONLY	CROSSOVER	
		14'-0"	15'-0"
9'-0"	8	16	16
10'-0"	16	32	32
11'-0"	7	14	14
12'-0"	6	12	12
12'-0" (Dapped)*	2	4	4
13'-0"	6	12	12
14'-0"	7	22	14
15'-0"	5	0	16
16'-0"	5	0	0
16'-6"	8	0	0
23'-0"	0	10	8
TOTAL NO.	70	122	128
BOARD MEAS.	4549.8	7881.5	8312.0

ALL SWITCH TIES ARE 7'X 9"  
 \* ADJUST THE NUMBER OF 12'-0" DAPPED TIES IF LAYOUT REQUIRES THE USE OF 13'-0", 14'-0", OR 16'-0" HEAD BLOCK TIES.

TURNOUT DATA		BILL OF TRACK MATERIAL		ORDERING INFORMATION		
	RBM	QUANTITY	DESCRIPTION	CLASS	ITEM	
FROG	NUMBER	10	NO. 10 RAILBOUND MANGANESE STEEL FROG, COMPLETE, PER DRAWING 2431 ROUNDED FOR SIGNALS.	OIO	6650171	
	TOTAL LENGTH	24'-5"				
	TOE LENGTH	10'-3"	2	GUARD RAILS - A-8 1/2" E. WITH A 7"-0" MINIMUM STRAIGHT GUARDING FACE.	OIO	6650170
	HEEL LENGTH	14'-2"				
	TOE SPREAD	11 13/16"	1	39"-0" STRAIGHT STOCK RAIL PER DRAWING 2307.	OIO	6650250
	HEEL SPREAD	17 1/2"	1	39"-0" BENT STOCK RAIL PER DRAWING 2307.	OIO	6650180
	ANGLE	5'-43"-29"	1	16'-6" LONG RAIL STRAIGHT SPLIT SWITCH, COMPLETE, WITH UNIFORM RISERS, PER DRAWINGS 2307, 2317, 2325, 2326, 2335, 2336, & 2337.	OIO	6650081
	LENGTH OF SWITCH POINT	16'-6"				
	HEEL SPREAD	6 1/4"				
	SWITCH ANGLE	1"-44"-11"	1	FRONT ROD ASSEMBLY PER S5001 AND S5044	OIO	6650295
SWITCH	THICKNESS OF POINT	1/4"	1	35"-8" RAIL WITH INSULATED JT. 12"-1"-23"-7" LEGS		
	VERTEX DISTANCE	8 1/4"	1	37"-2" RAIL WITH INSULATED JT. 7"-0"-30"-2" LEGS		
	ACTUAL LEAD	78'-9"	11	JOINTS, COMPLETE INCL. J CLIPS AND BOLTS		
	RADIUS OF CENTERLINE	779.39	200 lbs	TRACK SPIKES		
	DEGREE OF CURVE	7'-21"-24"	144	PANDROL TIE PLATES		
	1/2" PT. TO PT. OF CURVE	6'-5"	434	PANDROL CLIPS		
	STRAIGHT CLOSURE LENGTH	52'-0"	884	6 1/2" SCREW SPIKES OR 7/2" EVERGRIP SCREWS		
	CURVED CLOSURE LENGTH	52'-2"	223	FEET OF PREMIUM RAIL		

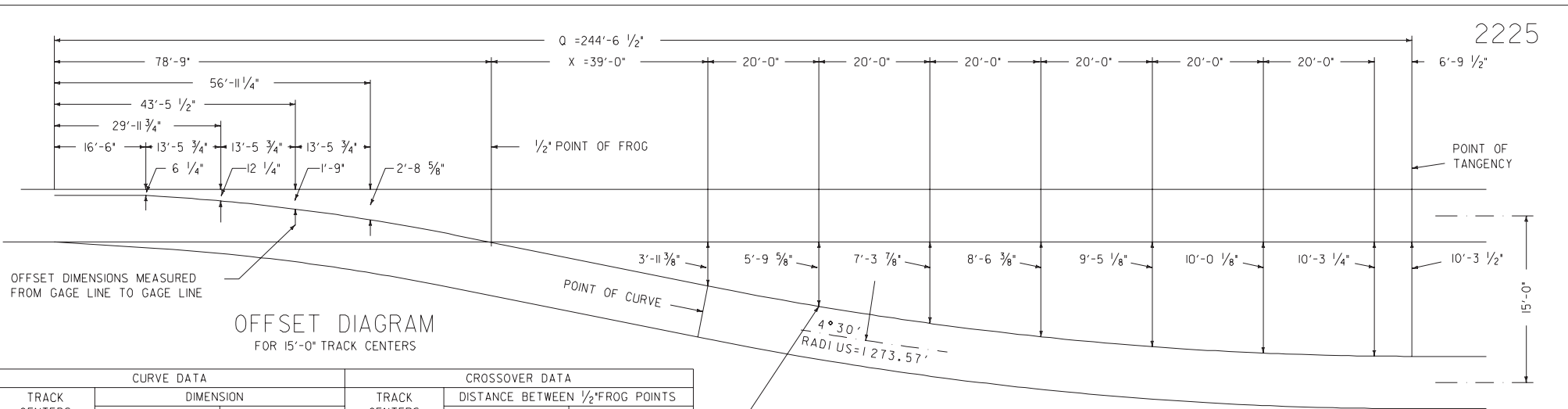

OFFSET DIMENSIONS MEASURED FROM GAGE LINE TO GAGE LINE

OFFSET DIAGRAM FOR 15'-0" TRACK CENTERS

OFFSET DIMENSIONS MEASURED FROM GAGE LINE TO GAGE LINE. FOR TRACK CENTERS OTHER THAN 15'-0" REDUCE OR INCREASE OFFSET DIMENSIONS BY SAME AMOUNT THAT TRACK CENTERS ARE INCREASED OR DECREASED FROM 15'-0", AND ADJUST 'X' DISTANCE.

IF INSULATED JOINTS ARE REQUIRED WITH 31'-6" LONG SWITCH POINT RAILS, USE PREMIUM INSULATED JOINTS IN THE FOLLOWING LENGTH RAILS. FOR RAILBOUND MANGANESE FROGS (DWG 2422). 37'-2" LONG WITH 7'-0" AND 30'-2" LEGS 35'-8" LONG WITH 12'-1" AND 23'-7" LEGS INSULATED JOINTS WILL HAVE A STAGGER OF AT LEAST 2'-6" BUT NOT MORE THAN 4'-6".

TRACK CENTERS	CURVE DATA		CROSSOVER DATA	
	Q	X	TRACK CENTERS	DISTANCE BETWEEN 1/2" FROG POINTS
13'-0"	224'-7 1/8"	19'-0 5/8"	15'-0"	54'-7 1/2"
14'-0"	234'-6 3/8"	29'-0 3/8"	14'-0"	44'-7 13/16"
15'-0"	244'-6 1/2"	39'-0"	1'-0" CHANGE	9'-11 1/16"
16'-0"	254'-6 1/4"	48'-11 3/4"	10'-0" CHANGE	10'-0 5/16"
10" CHANGE	9.974"	9.974"		9.974"

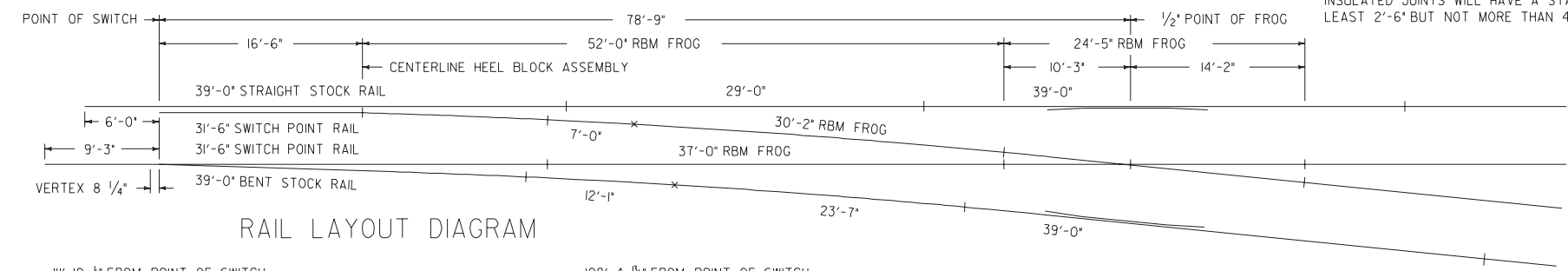

RAIL LAYOUT DIAGRAM

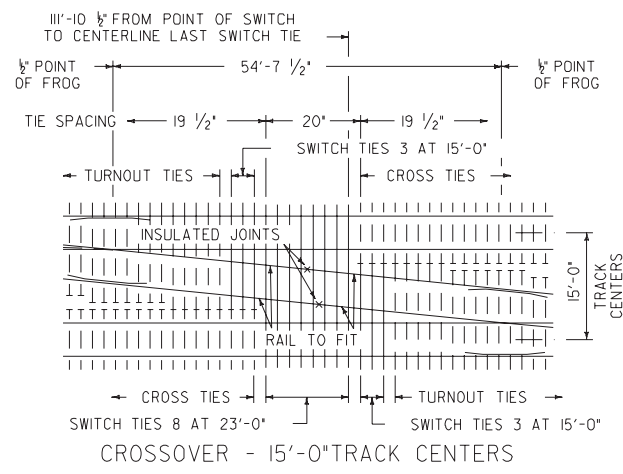

CROSSOVER - 15'-0" TRACK CENTERS

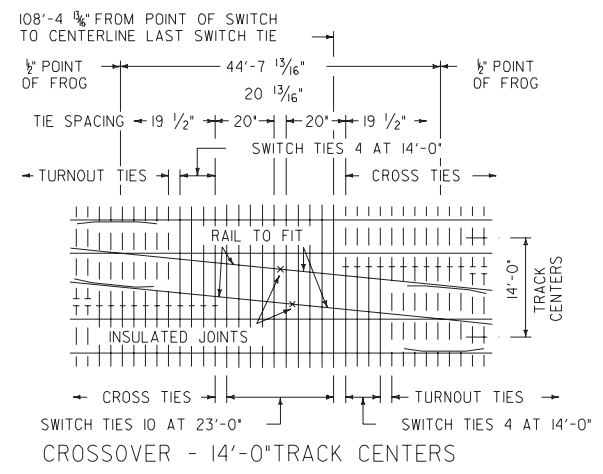

CROSSOVER - 14'-0" TRACK CENTERS



NUMBER 10 OFFSET AND LAYOUT DIAGRAMS WITH RAILBOUND MANGANESE FROG FOR 136RE RAIL

*Herold O'Neil* *M.E. McWaters*

APPROVED - DIRECTOR ENGINEERING STANDARDS

APPROVED - ASSISTANT VICE PRESIDENT ENGINEERING

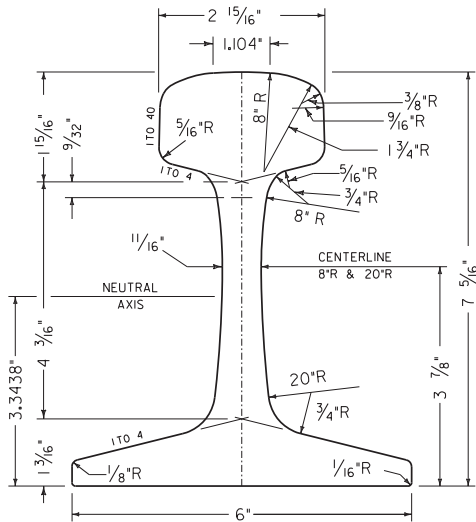

136 RE

AREA :  
 HEAD - 4.82 IN.<sup>2</sup> = 36.3 %  
 WEB - 3.64 IN.<sup>2</sup> = 27.1 %  
 BASE - 4.87 IN.<sup>2</sup> = 36.6 %

RAIL WEIGHT :  
 135.9 LBS./YD.

MOMENT OF INERTIA :  
 94.2 IN.<sup>4</sup>

SECTION MODULUS :  
 HEAD = 23.7 IN.<sup>3</sup>  
 BASE = 28.2 IN.<sup>3</sup>

NET TONS PER TRACK MILE :  
 239.36 TONS

RAIL DRILLING :  
 3 3/32 IN. ABOVE BASE

HEAD WIDTH :  
 MAXIMUM = 2.9375 IN.  
 AT GAGE PT. = 2.8903 IN.

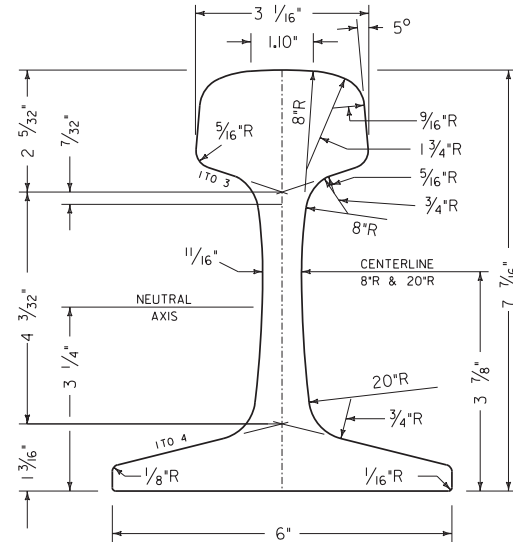

141 RE

AREA :  
 HEAD - 5.38 IN.<sup>2</sup> = 38.9 %  
 WEB - 3.56 IN.<sup>2</sup> = 25.8 %  
 BASE - 4.87 IN.<sup>2</sup> = 35.3 %

RAIL WEIGHT :  
 140.91 LBS./YD.

MOMENT OF INERTIA :  
 100.44 IN.<sup>4</sup>

SECTION MODULUS :  
 HEAD = 25.3 IN.<sup>3</sup>  
 BASE = 29.0 IN.<sup>3</sup>

NET TONS PER TRACK MILE :  
 248.00 TONS

RAIL DRILLING :  
 3 3/32 IN. ABOVE BASE

HEAD WIDTH :  
 MAXIMUM = 3.0625 IN.  
 AT GAGE PT. = 2.9063 IN.

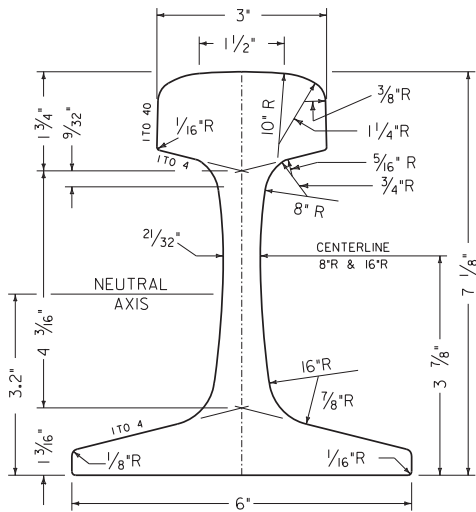

132 RE

AREA :  
 HEAD - 4.42 IN.<sup>2</sup> = 34.1 %  
 WEB - 3.66 IN.<sup>2</sup> = 28.3 %  
 BASE - 4.87 IN.<sup>2</sup> = 36.6 %

RAIL WEIGHT :  
 132.1 LBS./YD.

MOMENT OF INERTIA :  
 87.9 IN.<sup>4</sup>

SECTION MODULUS :  
 HEAD = 22.4 IN.<sup>3</sup>  
 BASE = 27.4 IN.<sup>3</sup>

NET TONS PER TRACK MILE :  
 232.32 TONS

RAIL DRILLING :  
 3 3/32 IN. ABOVE BASE

HEAD WIDTH :  
 MAXIMUM = 3.0000 IN.  
 AT GAGE PT. = 2.9650 IN.

**CSX** TRANSPORTATION

132 RE, 136 RE, AND 141 RE  
 RAIL SECTIONS

*K.A. Dornard*  
 APPROVED - CHIEF ENGINEER  
 MAINTENANCE OF WAY

*James D. Bayley*  
 APPROVED - VICE PRESIDENT  
 ENGINEERING

PREPARED BY:  
 D.C. CLARK

ISSUED: DECEMBER 7, 2000  
 REVISED: JUNE 22, 2007

FRA MAXIMUM ALLOWABLE OPERATING SPEEDS FOR CURVED TRACK · 4" UNBALANCE

2510

DEGREE OF CURVE	ELEVATION IN INCHES																									
	0	1/4	1/2	3/4	1	1-1/4	1-1/2	1-3/4	2	2-1/4	2-1/2	2-3/4	3	3-1/4	3-1/2	3-3/4	4	4-1/4	4-1/2	4-3/4	5	5-1/4	5-1/2	5-3/4	6	
	MAXIMUM ALLOWABLE OPERATING SPEEDS IN MILES PER HOUR																									
0° 10'	110	110	110	110	110	110	110	110	110	110	110	110	110	110	110	110	110	110	110	110	110	110	110	110	110	110
0° 20'	110	110	110	110	110	110	110	110	110	110	110	110	110	110	110	110	110	110	110	110	110	110	110	110	110	110
0° 30'	106	110	110	110	110	110	110	110	110	110	110	110	110	110	110	110	110	110	110	110	110	110	110	110	110	110
0° 40'	92	95	98	100	103	106	108	110	110	110	110	110	110	110	110	110	110	110	110	110	110	110	110	110	110	110
0° 50'	82	85	87	90	92	94	97	99	101	103	105	107	109	110	110	110	110	110	110	110	110	110	110	110	110	110
1° 00'	75	77	80	82	84	86	88	90	92	94	96	98	100	101	103	105	106	108	110	110	110	110	110	110	110	110
1° 15'	67	69	71	73	75	77	79	81	82	84	86	87	89	91	92	94	95	97	98	100	101	102	104	105	106	106
1° 30'	61	63	65	67	69	70	72	74	75	77	78	80	81	83	84	85	87	88	90	91	92	93	95	96	97	97
1° 45'	57	58	60	62	63	65	67	68	70	71	72	74	75	76	78	79	80	82	83	84	85	86	88	89	90	90
2° 00'	53	55	56	58	59	61	62	64	65	66	68	69	70	72	73	74	75	76	77	79	80	81	82	83	84	84
2° 15'	50	51	53	54	56	57	59	60	61	63	64	65	66	67	69	70	71	72	73	74	75	76	77	78	79	79
2° 30'	47	49	50	52	53	54	56	57	58	59	60	62	63	64	65	66	67	68	69	70	71	72	73	74	75	75
2° 45'	45	47	48	49	51	52	53	54	55	57	58	59	60	61	62	63	64	65	66	67	68	69	70	71	72	72
3° 00'	43	45	46	47	48	50	51	52	53	54	55	56	57	58	59	60	61	62	63	64	65	66	67	68	69	69
3° 15'	41	43	44	45	46	48	49	50	51	52	53	54	55	56	57	58	59	60	61	62	63	64	65	66	67	67
3° 30'	40	41	42	44	45	46	47	48	49	50	51	52	53	54	55	56	57	58	58	59	60	61	62	63	63	63
3° 45'	39	40	41	42	43	44	45	46	47	48	49	50	51	52	53	54	55	56	56	57	58	59	60	60	61	61
4° 00'	37	39	40	41	42	43	44	45	46	47	48	49	50	50	51	52	53	54	55	55	56	57	58	59	59	59
4° 30'	35	36	37	38	39	40	41	42	43	44	45	46	47	48	48	49	50	51	51	52	53	54	54	55	56	56
5° 00'	33	34	35	36	37	38	39	40	41	42	43	43	44	45	46	47	47	48	49	50	50	51	52	52	53	53
5° 30'	32	33	34	35	36	36	37	38	39	40	41	41	42	43	44	44	45	46	47	47	48	49	49	50	51	51
6° 00'	30	31	32	33	34	35	36	37	37	38	39	40	40	41	42	43	43	44	45	45	46	46	47	48	48	48
6° 30'	29	30	31	32	33	34	34	35	36	37	37	38	39	39	40	41	41	42	43	43	44	45	45	46	46	46
7° 00'	28	29	30	31	31	32	33	34	35	35	36	37	37	38	39	39	40	41	41	42	42	43	44	44	45	45
8° 00'	26	27	28	29	29	30	31	32	32	33	34	34	35	36	36	37	37	38	39	39	40	40	41	41	42	42
9° 00'	25	26	26	27	28	28	29	30	30	31	32	32	33	33	34	35	35	36	36	37	37	38	38	39	39	39
10° 00'	23	24	25	26	26	27	28	28	29	29	30	31	31	32	32	33	33	34	34	35	35	36	36	37	37	37
11° 00'	22	23	24	24	25	26	26	27	27	28	29	29	30	30	31	31	32	32	33	33	34	34	35	35	36	36
12° 00'	21	22	23	23	24	25	25	26	26	27	27	28	28	29	29	30	30	31	31	32	32	33	33	34	34	34
13° 00'	21	21	22	22	23	24	24	25	25	26	26	27	27	28	28	29	29	30	30	31	31	31	32	32	33	33
14° 00'	20	20	21	22	22	23	23	24	24	25	25	26	26	27	27	28	28	29	29	29	30	30	31	31	31	31
15° 00'	19	20	20	21	21	22	22	23	23	24	24	25	25	26	26	27	27	28	28	28	29	29	30	30	30	30
16° 00'	18	19	20	20	21	21	22	22	23	23	24	24	25	25	25	26	26	27	27	28	28	28	29	29	29	29
17° 00'	18	18	19	20	20	21	21	22	22	22	23	23	24	24	25	25	25	26	26	27	27	27	28	28	29	29
18° 00'	17	18	18	19	19	20	20	21	21	22	22	23	23	24	24	24	25	25	26	26	26	27	27	27	28	28
19° 00'	17	17	18	18	19	19	20	20	21	21	22	22	22	23	23	24	24	24	25	25	26	26	26	27	27	27
20° 00'	16	17	17	18	18	19	19	20	20	21	21	22	22	22	23	23	23	24	24	25	25	25	26	26	26	26

AFTER DETERMINING THE SUPERELEVATION REQUIRED BASED ON FREIGHT TRAIN SPEED CURRENT EXISTING INSTRUCTIONS, THIS TABLE IS TO BE USED TO DETERMINE THE ALLOWABLE OPERATING SPEED FOR PASSENGER TRAINS BASED ON THE DEGREE OF CURVE AND THE NEW SUPERELEVATION.

THE MAXIMUM ALLOWABLE OPERATING SPEED FOR EACH CURVE IS DETERMINED BY THE FOLLOWING FORMULA:

$$V_{MAX} = \sqrt{\frac{E_A \cdot 4}{0.0007D}}$$

- V<sub>MAX</sub> = MAXIMUM ALLOWABLE OPERATING SPEED (MILES PER HOUR).
- E<sub>A</sub> = ACTUAL ELEVATION OF THE OUTSIDE RAIL (INCHES).
- D = DEGREE OF CURVATURE (DEGREES).

110+ INDICATES CALCULATED SPEED IS GREATER THAN, BUT LIMITED TO 110 MPH.



FRA MAXIMUM AUTHORIZED SPEEDS FOR CURVED TRACK 4" UNBALANCE

SIGNED

REVIEWED · DIRECTOR, ENGINEERING STANDARDS

PREPARED BY, D. N. WITT

SIGNED

APPROVED · CHIEF ENGINEER MAINTENANCE OF WAY

ISSUED JUNE 14, 1999  
REVISED, INITIAL ISSUE

FRA MAXIMUM ALLOWABLE PASSENGER TRAIN OPERATING SPEEDS FOR CURVED TRACK · 3" UNBALANCE

2510

DEGREE OF CURVE	ELEVATION IN INCHES																									
	0	1/4	1/2	3/4	1	1-1/4	1-1/2	1-3/4	2	2-1/4	2-1/2	2-3/4	3	3-1/4	3-1/2	3-3/4	4	4-1/4	4-1/2	4-3/4	5	5-1/4	5-1/2	5-3/4	6	
	MAXIMUM ALLOWABLE OPERATING SPEEDS IN MILES PER HOUR																									
0° 10'	110*	110*	110*	110*	110*	110*	110*	110*	110*	110*	110*	110*	110*	110*	110*	110*	110*	110*	110*	110*	110*	110*	110*	110*	110*	110*
0° 20'	110*	110*	110*	110*	110*	110*	110*	110*	110*	110*	110*	110*	110*	110*	110*	110*	110*	110*	110*	110*	110*	110*	110*	110*	110*	110*
0° 30'	92	96	100	103	106	110	110*	110*	110*	110*	110*	110*	110*	110*	110*	110*	110*	110*	110*	110*	110*	110*	110*	110*	110*	110*
0° 40'	80	83	86	89	92	95	98	100	103	106	108	110*	110*	110*	110*	110*	110*	110*	110*	110*	110*	110*	110*	110*	110*	110*
0° 50'	71	74	77	80	82	85	87	90	92	94	97	99	101	103	105	107	109	110*	110*	110*	110*	110*	110*	110*	110*	110*
1° 00'	65	68	70	73	75	77	80	82	84	86	88	90	92	94	96	98	100	101	103	105	106	108	110	110*	110*	110*
1° 15'	58	60	63	65	67	69	71	73	75	77	79	81	82	84	86	87	89	91	92	94	95	97	98	100	101	101
1° 30'	53	55	57	59	61	63	65	67	69	70	72	74	75	77	78	80	81	83	84	85	87	88	90	91	92	92
1° 45'	49	51	53	55	57	58	60	62	63	65	67	68	70	71	72	74	75	76	78	79	80	82	83	84	85	85
2° 00'	46	48	50	51	53	55	56	58	59	61	62	64	65	66	68	69	70	72	73	74	75	76	77	79	80	80
2° 15'	43	45	47	48	50	51	53	54	56	57	59	60	61	63	64	65	66	67	69	70	71	72	73	74	75	75
2° 30'	41	43	44	46	47	49	50	52	53	54	56	57	58	59	60	62	63	64	65	66	67	68	69	70	71	71
2° 45'	39	41	42	44	45	47	48	49	51	52	53	54	55	57	58	59	60	61	62	63	64	65	66	67	68	68
3° 00'	37	39	40	42	43	45	46	47	48	50	51	52	53	54	55	56	57	58	59	60	61	62	63	64	65	65
3° 15'	36	37	39	40	41	43	44	45	46	48	49	50	51	52	53	54	55	56	57	58	59	60	61	62	62	62
3° 30'	35	36	37	39	40	41	42	44	45	46	47	48	49	50	51	52	53	54	55	56	57	58	58	59	60	60
3° 45'	33	35	36	37	39	40	41	42	43	44	45	46	47	48	49	50	51	52	53	54	55	56	56	57	58	58
4° 00'	32	34	35	36	37	39	40	41	42	43	44	45	46	47	48	49	50	50	51	52	53	54	55	55	56	56
4° 30'	30	32	33	34	35	36	37	38	39	40	41	42	43	44	45	46	47	48	48	49	50	51	51	52	53	53
5° 00'	29	30	31	32	33	34	35	36	37	38	39	40	41	42	43	43	44	45	46	47	47	48	49	50	50	50
5° 30'	27	29	30	31	32	33	34	35	36	36	37	38	39	40	41	41	42	43	44	44	45	46	47	47	48	48
6° 00'	26	27	28	29	30	31	32	33	34	35	36	37	37	38	39	40	40	41	42	43	43	44	45	45	46	46
6° 30'	25	26	27	28	29	30	31	32	33	34	34	35	36	37	37	38	39	39	40	41	41	42	43	43	44	44
7° 00'	24	25	26	27	28	29	30	31	31	32	33	34	35	35	36	37	37	38	39	39	40	41	41	42	42	42
8° 00'	23	24	25	25	26	27	28	29	29	30	31	32	32	33	34	34	35	36	36	37	37	38	39	39	40	40
9° 00'	21	22	23	24	25	26	26	27	28	28	29	30	30	31	32	32	33	33	34	35	35	36	36	37	37	37
10° 00'	20	21	22	23	23	24	25	26	26	27	28	28	29	29	30	31	31	32	32	33	33	34	34	35	35	35
11° 00'	19	20	21	22	22	23	24	24	25	26	26	27	27	28	29	29	30	30	31	31	32	32	33	33	34	34
12° 00'	18	19	20	21	21	22	23	23	24	25	25	26	26	27	27	28	28	29	29	30	30	31	31	32	32	32
13° 00'	18	18	19	20	21	21	22	22	23	24	24	25	25	26	26	27	27	28	28	29	29	30	30	31	31	31
14° 00'	17	18	18	19	20	20	21	22	22	23	23	24	24	25	25	26	26	27	27	28	28	29	29	29	30	30
15° 00'	16	17	18	18	19	20	20	21	21	22	22	23	23	24	24	25	25	26	26	27	27	28	28	28	29	29
16° 00'	16	17	17	18	18	19	20	20	21	21	22	22	23	23	24	24	25	25	25	26	26	27	27	28	28	28
17° 00'	15	16	17	17	18	18	19	20	20	21	21	22	22	22	23	23	24	24	25	25	25	26	26	27	27	27
18° 00'	15	16	16	17	17	18	18	19	19	20	20	21	21	22	22	23	23	24	24	24	25	25	26	26	26	26
19° 00'	15	15	16	16	17	17	18	18	19	19	20	20	21	21	22	22	22	23	24	24	24	25	25	26	26	26
20° 00'	14	15	15	16	16	17	17	18	18	19	19	20	20	21	21	22	22	22	23	23	23	24	24	25	25	25

AFTER DETERMINING THE SUPERELEVATION REQUIRED BASED ON FREIGHT TRAIN SPEED CURRENT EXISTING INSTRUCTIONS, THIS TABLE IS TO BE USED TO DETERMINE THE ALLOWABLE OPERATING SPEED FOR PASSENGER TRAINS BASED ON THE DEGREE OF CURVE AND THE NEW SUPERELEVATION.

THE MAXIMUM ALLOWABLE OPERATING SPEED FOR EACH CURVE IS DETERMINED BY THE FOLLOWING FORMULA:

$$V_{MAX} = \sqrt{\frac{E_A \cdot 3}{0.0007D}}$$

V<sub>MAX</sub> = MAXIMUM ALLOWABLE OPERATING SPEED (MILES PER HOUR).

E<sub>A</sub> = ACTUAL ELEVATION OF THE OUTSIDE RAIL (INCHES).

D = DEGREE OF CURVATURE (DEGREES).

110\* INDICATES CALCULATED SPEED IS GREATER THAN, BUT LIMITED TO 110 MPH.



FRA MAXIMUM AUTHORIZED SPEEDS FOR CURVED TRACK 3" UNBALANCE

SIGNED

REVIEWED · DIRECTOR, ENGINEERING STANDARDS

SIGNED

APPROVED · CHIEF ENGINEER MAINTENANCE OF WAY

PREPARED BY, D. N. WITT

ISSUED, MARCH 24, 1997  
REVISED, JUNE 14, 1999



INCHES SUBTRACTED	SPEED IN MILES PER HOUR	DEGREE OF CURVE																																			
		0° - 10'	0° - 20'	0° - 30'	0° - 40'	0° - 50'	1° - 00'	1° - 15'	1° - 30'	1° - 45'	2° - 00'	2° - 15'	2° - 30'	2° - 45'	3° - 00'	3° - 15'	3° - 30'	3° - 45'	4° - 00'	4° - 30'	5° - 00'	5° - 30'	6° - 00'	6° - 30'	7° - 00'	8° - 00'	9° - 00'	10° - 00'	11° - 00'	12° - 00'	14° - 00'	16° - 00'	18° - 00'	20° - 00'			
EQUILIBRIUM ELEVATION MINUS 1 1/2" OR 2 1/2" BASED ON SPEED																																					
1/2"	10						1/2	1/2	1/2	1/2	1/2	1/2	1/2	1/2	1/2	1/2	1/2	1/2	1/2	1/2	1/2	1/2	1/2	1/2	1/2	1/2	1/2	1/2	1/2	1/2	1/2	1/2	1/2	1/2			
	20					1/2	1/2	1/2	1/2	1/2	1/2	1/2	1/2	1/2	1/2	1/2	1/2	1/2	1/2	1/2	1/2	1/2	1/2	1/2	1/2	1/2	3/4	1	1 1/4	1 1/2	1 3/4	2 1/2	3	3 1/2	4		
	25				1/2	1/2	1/2	1/2	1/2	1/2	1/2	1/2	1/2	1/2	1/2	1/2	1/2	1/2	1/2	3/4	1	1	1 1/4	1 1/2	2	2 1/2	2 3/4	3 1/4	3 3/4	4 1/2							
	30			1/2	1/2	1/2	1/2	1/2	1/2	1/2	1/2	1/2	1/2	1/2	1/2	3/4	3/4	1	1 1/4	1 3/4	2	2 1/4	2 1/2	3	3 1/2	4 1/4											
	35		1/2	1/2	1/2	1/2	1/2	1/2	1/2	1/2	1/2	3/4	3/4	1	1 1/4	1 1/2	1 3/4	2	2 1/2	2 3/4	3 1/4	3 1/2	4	4 1/2													
	40	1/2	1/2	1/2	1/2	1/2	1/2	1/2	1/2	1/2	3/4	1	1 1/4	1 1/2	1 3/4	2 1/4	2 1/2	2 3/4	3	3 1/2	4	4 1/2															
	45	1/2	1/2	1/2	1/2	1/2	1/2	1/2	3/4	1	1 1/4	1 3/4	2	2 1/2	2 3/4	3	3 1/2	3 3/4	4 1/4																		
	50	1/2	1/2	1/2	1/2	1/2	1/2	3/4	1 1/4	1 1/2	2	2 1/2	3	3 1/4	3 3/4	4 1/4																					
	2 1/2"	55	1/2	1/2	1/2	1/2	1/2	1/2	1 1/4	1 3/4	2 1/4	2 3/4	3 1/4	3 3/4	4 1/4	4 3/4																					
60		1/2	1/2	1/2	1/2	1/2	1	1 3/4	2 1/4	3	3 1/2	4 1/4	4 3/4																								
65		1/2	1/2	1/2	1/2	1/2	1/2	1 1/4	2	2 3/4	3 1/2	4 1/4	5																								
	70	1/2	1/2	1/2	1/2	1/2	1	1 3/4	2 3/4	3 1/2	4 1/4																										

THE REGIONAL ENGINEER TRACK WILL USE THIS TABLE TO DETERMINE SUPERELEVATION AND ENTER INTO SCREEN OECV.

FIELD PERSONNEL ARE TO USE SCREEN OECV TO FIND THE SUPERELEVATION REQUIRED FOR A SPECIFIC CURVE.

LIMITS ON SUPERELEVATION FOUND ON THIS PAGE MUST BE OBSERVED.

TABLE BASED ON EQUILIBRIUM ELEVATION MINUS AN UNBALANCE BASED ON SPEED AS FOLLOWS AND ADJUSTED TO NEAREST 1/4".  
 1 1/2" UNBALANCED FOR SPEEDS UP TO AND INCLUDING 60 MPH  
 2 1/2" UNBALANCED FOR SPEEDS OF 65 AND 70 MPH

NOTE - E = 0.0007V<sup>2</sup>D  
 WHERE E = EQUILIBRIUM ELEVATION IN INCHES

LIMITS ON SUPERELEVATION

- 5" MAXIMUM SUPERELEVATION ON ANY CURVE.
- 4 1/2" SUPERELEVATION ON CURVES GREATER THAN 3 - 00' WHEN REQUIRED TO MAINTAIN MAXIMUM AUTHORIZED SPEED.
- 4" SUPERELEVATION ON NON-SIGNALED BRANCH LINES HAVING A MAXIMUM AUTHORIZED SPEED OF 30 MPH OR LESS.
- 4" SUPERELEVATION ON GRADES WHERE FREIGHT TRAINS REGULARLY OPERATE BELOW 25 MPH.
- CURVES SHALL BE REGULARLY EXAMINED FOR PREMATURE OR ACCELERATED WEAR ON THE HIGH OR LOW RAIL. A REQUEST FOR A DEVIATION FROM THE STANDARD SUPERELEVATION MUST BE SUBMITTED ON FORM "ELEVATION CHANGE REQUEST" TO CHIEF ENGINEER, MAINTENANCE OF WAY FOR CONCURRENCE.

MINIMUM LENGTH OF SPIRAL

MAXIMUM AUTHORIZED SPEED IN MPH	MINIMUM SPIRAL LENGTH PER 1/2 INCH OF SUPERELEVATION
NEW CONSTRUCTION AND EXISTING TRACKS WHERE PRACTICAL.	
UP TO 50	31 FEET
55 TO 60	39 FEET
70 TO 80	50 FEET
85 AND 90	55 FEET
EXISTING TRACKS	
UP TO 50	31 FEET
55 TO 80	39 FEET
85 AND UP	50 FEET



SUPERELEVATION OF CURVES

REVIEWED - GENERAL MANAGER  
 ENGINEERING STANDARDS &  
 INDUSTRIAL ENGINEERING

APPROVED - CHIEF ENGINEER  
 MAINTENANCE OF WAY

PREPARED BY:  
 D. N. WITT

ISSUED, MARCH 24, 1997  
 REVISED, NOVEMBER 25, 2002

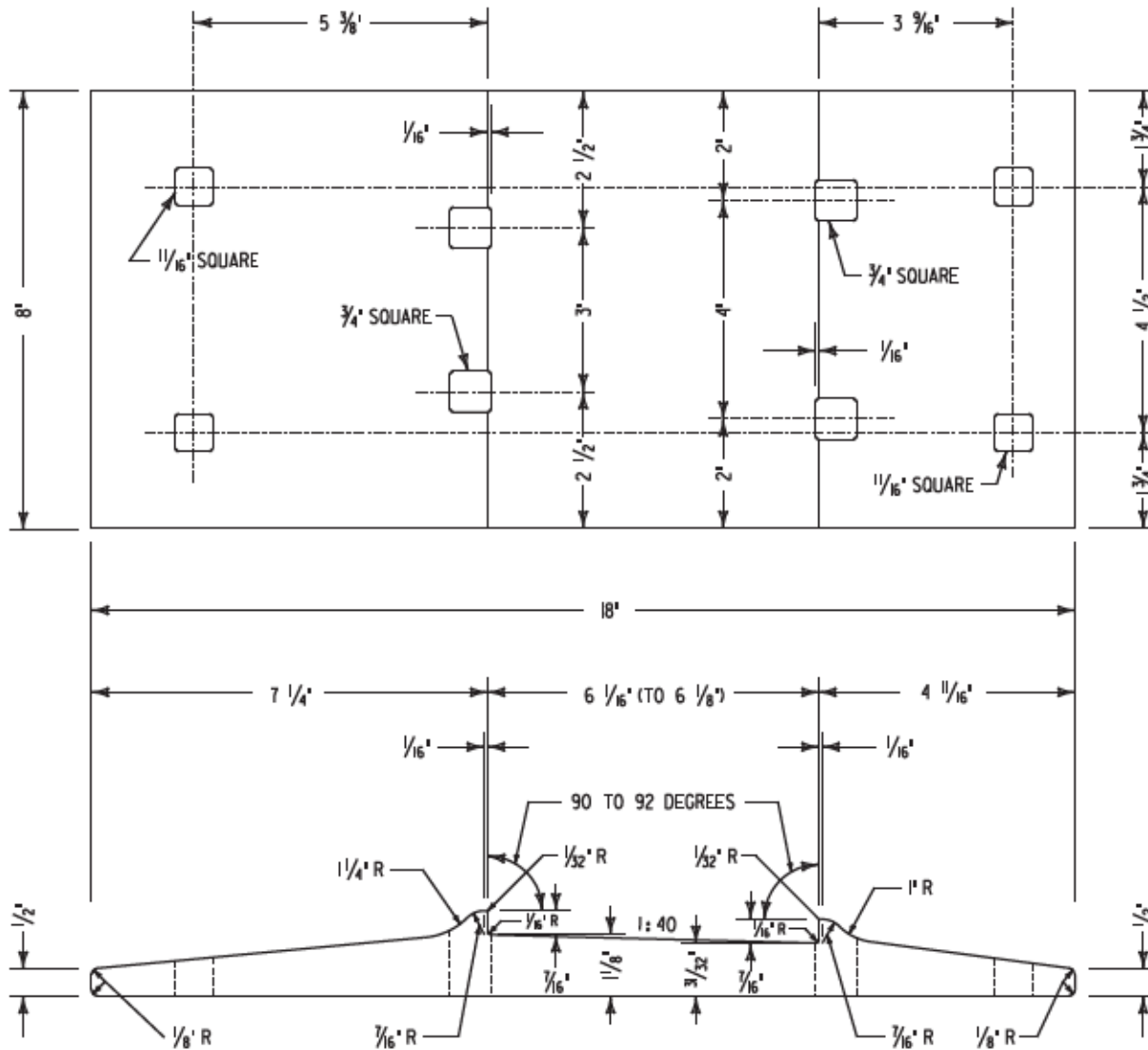

NOTES

1. PLATES ARE TO BE FURNISHED WITHOUT RIBS.
2. RAIL SEAT IS TO BE FLAT, WITHOUT CAMBER.
3. ALL SPIKE HOLES USE 1/16" FILLETS IN THE CORNERS.
4. PLATES TO BE BRANDED IN ACCORDANCE WITH SECTION 5 OF THE AREMA MANUAL.
5. MATERIAL AND PROCESS ARE TO CONFORM TO AREMA STANDARDS.  
 CARBON - 0.40 % MIN.  
 COPPER - 0.20 % MIN.
6. ESTIMATED WEIGHT - 36.52 LBS.

RELAY PLATE LIMITS

1. SHOULDER HEIGHT - 1/32" MINIMUM
2. RAIL SEAT WIDTH - 6-1/4" MAXIMUM
3. SPIKE HOLE SIZE - 2 7/32" MAXIMUM
4. PLATE THICKNESS AT EDGE - 15/32" MINIMUM
5. RAIL SEAT FLATNESS - 1/16" MAXIMUM
6. PLATE BOTTOM FLATNESS - 1/8" MAXIMUM



8" X 18" TIE PLATE  
FOR 6" BASE RAIL SECTIONS

*[Signature]*  
APPROVED - DIRECTOR  
ENGINEERING STANDARDS

*[Signature]*  
APPROVED - CHIEF ENGINEER  
ENGINEERING SERVICES

ORDERING INFORMATION			
DESCRIPTION	UNITS	CLASS	ITEM
PLATE, TIE, 8" X 18" FOR 6" BASE RAILS	EACH	013	6150675

PREPARED BY:  
M. E. AUSTIN

ISSUED: JANUARY 1, 2005  
REVISED: OCTOBER 28, 2014

NOTES

1. MWI 901 (LATEST REVISION) IS TO BE USED IN CONJUNCTION WITH THIS DRAWING.
2. FOR NEW CONSTRUCTION, HIGHWAY SHOULD INTERSECT RAILROAD AT OR NEARLY RIGHT ANGLES.
3. FOR NEW CONSTRUCTION, HIGHWAY SURFACE SHOULD NOT BE MORE THAN 3" HIGHER OR LOWER THAN TOP OF THE NEAR RAIL 30' FROM THE RAIL ALONG THE ROAD CENTERLINE, UNLESS TRACK SUPERELEVATION DICTATES OTHERWISE.
4. USE STATE D.O.T. SPECIFICATIONS FOR BITUMINOUS CONCRETE AND ASPHALT SPRAY TACK COAT FOR THE STATE IN WHICH THE CROSSING IS LOCATED.
5. CROSSINGS SHOULD BE CONTINUOUS BETWEEN ROADWAY OR SIDEWALK EDGES. IF NOT PRACTICABLE, ADEQUATE DRAINAGE MUST BE PROVIDED BETWEEN CROSSING AREAS TO ELIMINATE WATER POCKETS.
6. USE TWO CLAMPS PER CRIB OR FOUR (4) RUBBER INTERFACE HOLDING SPIKES PER TIE.
7. SLOPE PAVING TO RETURN TO ORIGINAL PAVEMENT SURFACE. LENGTH OF TRANSITION WILL DEPEND ON LOCAL CONDITIONS. USE A RUNOFF OF 1 IN. PER 10 FT. WHERE PRACTICABLE.
8. IF ROADBED STABILIZATION IS REQUIRED, EXTEND IT 10 FT. BEYOND EDGE OF CROSSING UNDER TRACK.
9. PERFORATED PIPE TO BE SIZED AND LOCATED FOR SITE CONDITIONS. USE MIN. 6" DIA. PIPE AND LOCATE AT LEAST 12" BEYOND THE END OF TIE.

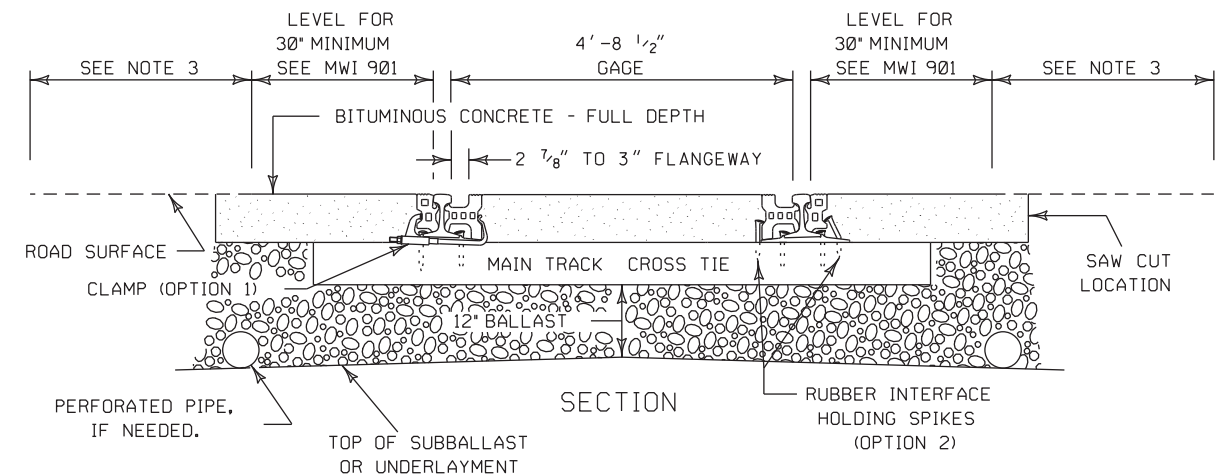
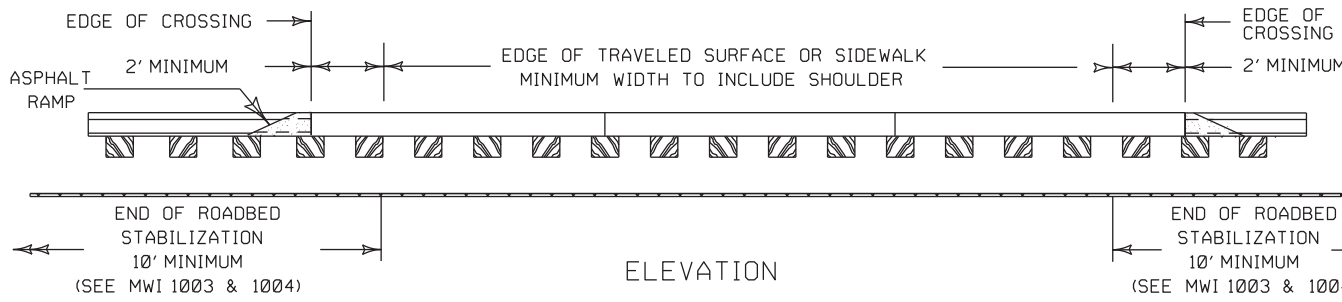
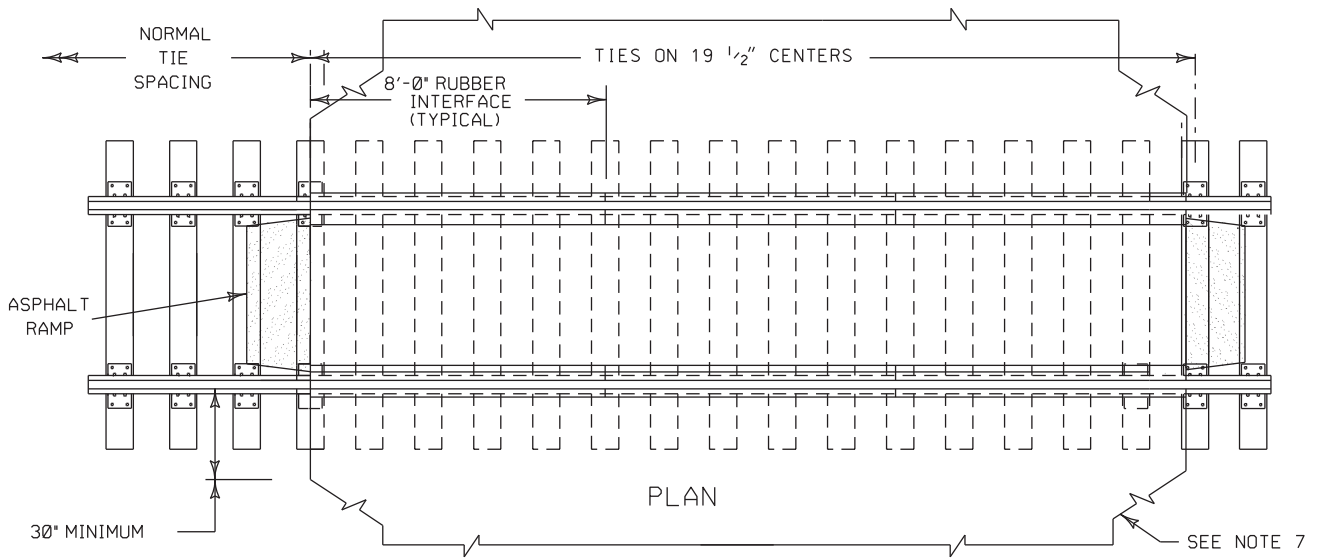

ORDERING INFORMATION		
ITEM NO.	RAIL WGT.	DESCRIPTION
014 5250135	90-100	CROSSING RUBBER INTERFACE, LIGHT DUTY. ORDER BY "TRACK FEET" IN 8 FT. INCREMENTS. EACH TRACK FOOT INCLUDES 2 GAGE SIDE AND 2 FIELD SIDE SECTIONS.
014 5250140	115	
014 5250142	122	
014 5250145	132	
014 5250147	136	
014 5250160	140	
014 5250170	141	
014 5250260	90-141	CLAMP, RUBBER INTERFACE USE 2 PER CRIB.



NORMAL AND LIGHT DUTY ROAD CROSSING ASPHALT AND RUBBER INTERFACE ON WOOD TIES

*[Signature]*  
 APPROVED DIRECTOR  
 ENGINEERING STANDARDS

*[Signature]*  
 APPROVED - CHIEF ENGINEER  
 ENGINEERING SERVICES

PREPARED BY:  
 M. E. AUSTIN

ISSUED: MAY 27, 1997  
 REVISED: SEPTEMBER 18, 2014

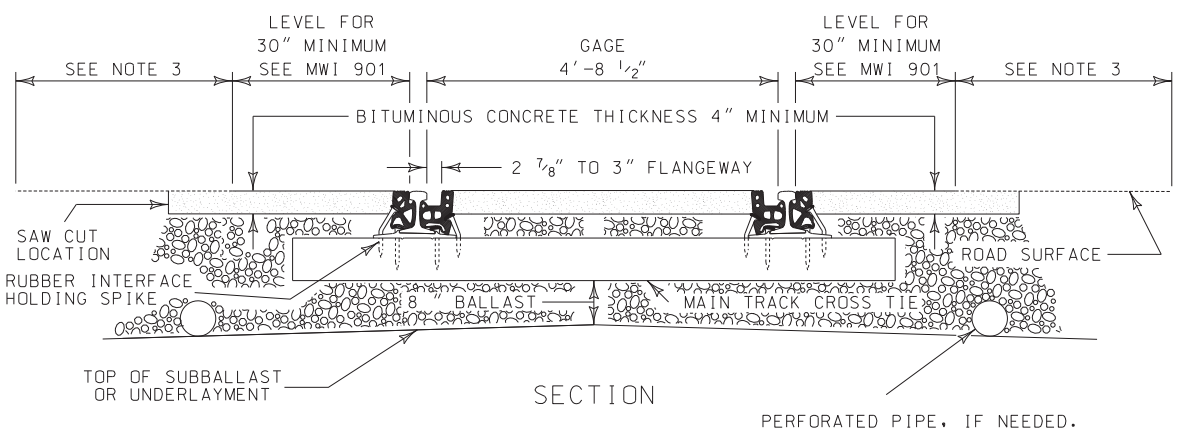
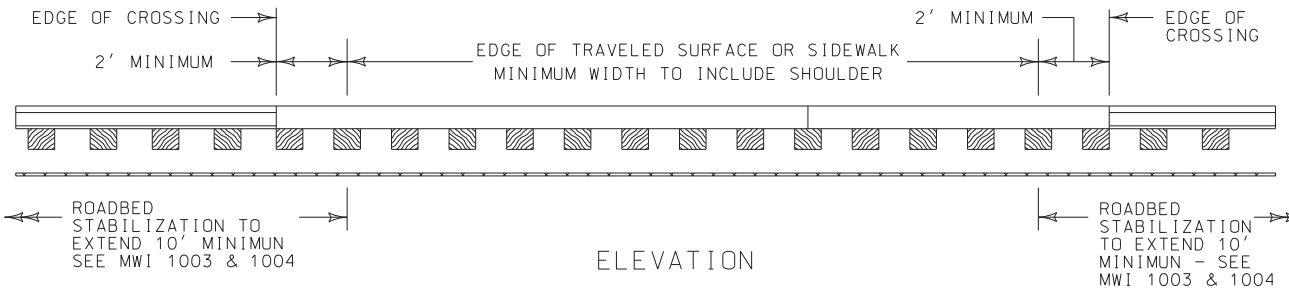
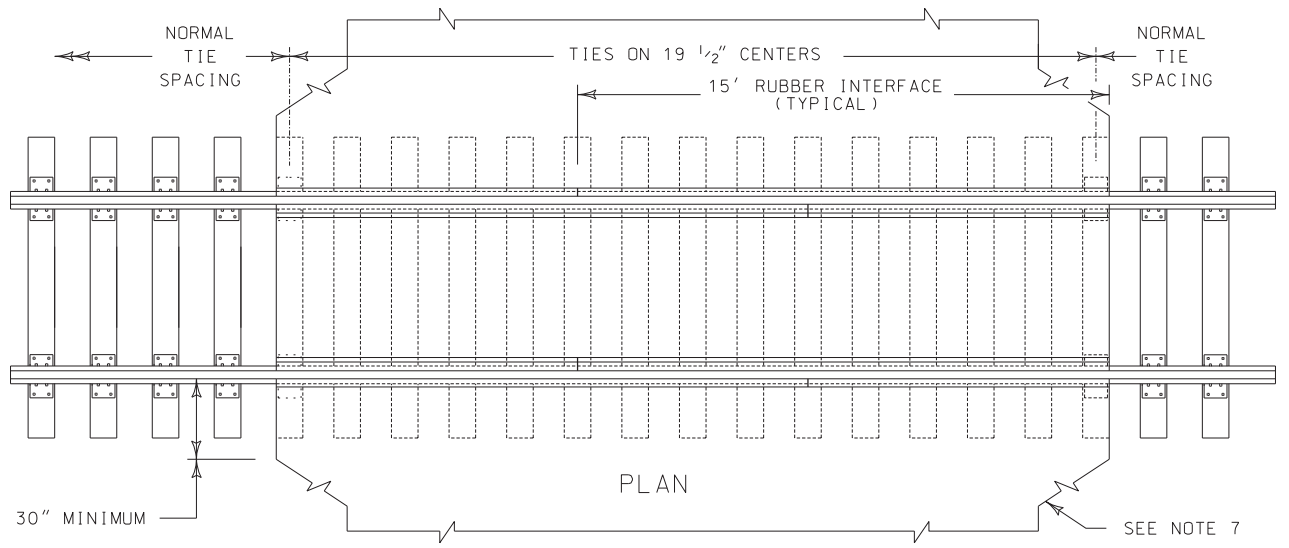

NOTES

1. MWI 901 (LASTEST REVISION) IS TO BE USED IN CONJUNCTION WITH THIS DRAWING.
2. FOR NEW CONSTRUCTION, HIGHWAY SHOULD INTERSECT RAILROAD AT OR NEARLY RIGHT ANGLES.
3. FOR NEW CONSTRUCTION, HIGHWAY SURFACE SHOULD NOT BE MORE THAN 3" HIGHER OR LOWER THAN TOP OF NEAR RAIL 30' FROM RAIL ALONG THE ROAD CENTERLINE, UNLESS TRACK SUPERELEVATION DICTATES OTHERWISE.
4. USE STATE D.O.T. SPECIFICATIONS FOR BITUMINOUS CONCRETE AND ASPHALT TACK COAT FOR THE STATE IN WHICH THE CROSSING IS LOCATED.
5. CROSSINGS SHOULD BE CONTINUOUS BETWEEN ROADWAY OR SIDEWALK EDGES. IF NOT PRACTICABLE, ADEQUATE DRAINAGE MUST BE PROVIDED BETWEEN CROSSING AREAS TO ELIMINATE WATER POCKETS.
6. USE FOUR (4) PANEL HOLDING SPIKES PER TIE, OR TWO (2) CLAMPS IN ALTERNATE CRIBS.
7. SLOPE PAVING TO RETURN TO ORIGINAL PAVEMENT SURFACE. LENGTH OF TRANSITION WILL DEPEND ON LOCAL CONDITIONS. USE A RUNOFF OF 1 IN. PER 10 FT. WHERE PRACTICABLE.
8. IF ROADBED STABILIZATION IS REQUIRED, EXTEND IT 10 FT. BEYOND EDGE OF CROSSING UNDER TRACK.
9. PERFORATED PIPE TO BE SIZED AND LOCATED FOR SITE CONDITIONS. USE MIN. 6" DIA. PIPE AND LOCATE AT LEAST 12" BEYOND END OF TIE.

ORDERING INFORMATION		
ITEM NO.	RAIL WGT.	DESCRIPTION
014 5250135	90-100	CROSSING RUBBER INTERFACE, LIGHT DUTY. ORDER BY "TRACK FEET" IN 5 FT. INCREMENTS. EACH TRACK FOOT INCLUDES 2 GAGE SIDE AND 2 FIELD SIDE SECTIONS. INTERFACE DELIVERED IN 5', 10' OR 15' SECTIONS.
014 5250140	115	
014 5250142	122	
014 5250145	132	
014 5250147	136	
014 5250160	140	
014 5250170	141	
014 5250260	90-141	CLAMP, RUBBER INTERFACE USE 2 PER CRIB.



FARM / RESIDENTIAL ROAD CROSSING  
ASPHALT AND RUBBER INTERFACE ON WOOD TIES

*[Signature]*  
APPROVED - VICE PRESIDENT  
ENGINEERING AND MECHANICAL  
STANDARDS AND QUALITY

*[Signature]*  
APPROVED - VICE PRESIDENT  
ENGINEERING

PREPARED BY:  
J. E. BEYERL

ISSUED, MAY 29, 1998  
REVISED, MARCH 22, 2005

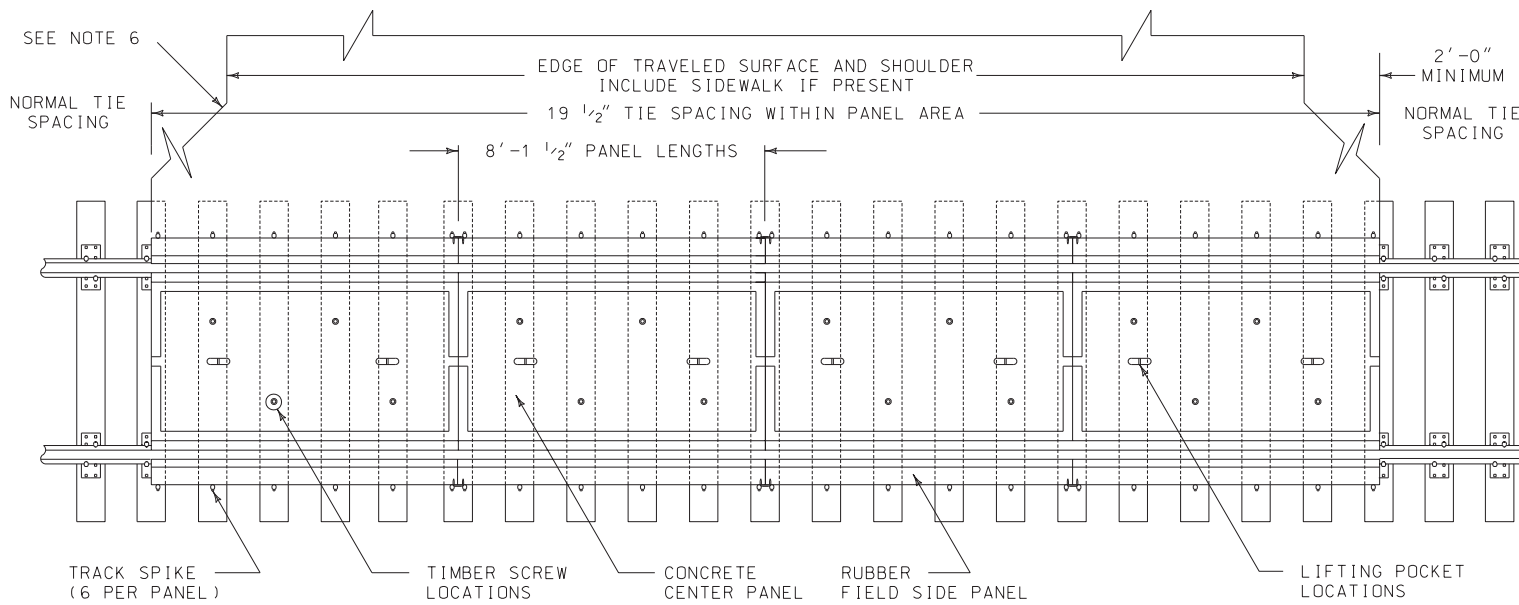

CROSSING PLAN VIEW

NOTES

1. MWI 901 (LATEST REVISION) IS TO BE USED IN CONJUNCTION WITH THIS DRAWING.
2. FOR NEW CONSTRUCTION, HIGHWAY SHOULD INTERSECT RAILROAD AT OR NEARLY RIGHT ANGLES.
3. FOR NEW CONSTRUCTION, HIGHWAY SURFACE SHOULD NOT BE MORE THAN 3 IN. HIGHER OR LOWER THAN TOP OF NEAR RAIL 30 FT. FROM THE RAIL ALONG THE ROAD CENTERLINE, UNLESS TRACK SUPERELEVATION DICTATES OTHERWISE.
4. USE STATE DOT SPECIFICATIONS FOR BITUMINOUS CONCRETE AND ASPHALT SPRAY TACK COAT FOR THE STATE IN WHICH THE CROSSING IS LOCATED.
5. CROSSING SHOULD BE CONTINUOUS BETWEEN ROADWAY OR SIDEWALK EDGES. IF NOT PRACTICABLE, DRAINAGE MUST BE PROVIDED BETWEEN PAVED AREAS TO ELIMINATE WATER POCKETS.
6. SLOPE PAVING TO RETURN TO PAVEMENT SURFACE. LENGTH OF TRANSITION WILL DEPEND ON LOCAL CONDITIONS. USE A RUNOFF OF 1 IN. PER 10 FT. WHERE PRACTICABLE.
7. IF ROADBED STABILIZATION IS REQUIRED, EXTEND IT 10 FT BEYOND EDGE OF CROSSING UNDER TRACK.
8. APPROXIMATE WEIGHT FOR 136# MATERIALS:  
3,200 LBS. - CONCRETE CENTER PANEL  
275 LBS. - RUBBER FIELD SIDE PANEL

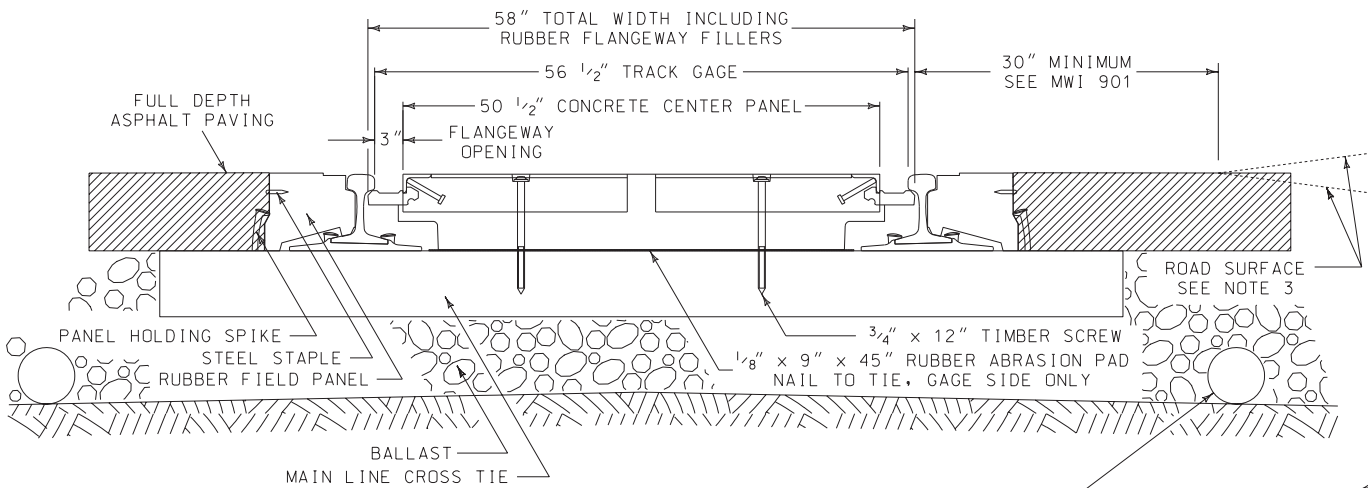

SECTION

PERFORATED PIPE, IF NEEDED, TO BE SIZED AND LOCATED FOR SITE CONDITIONS, USING 6" MIN. DIA PIPE AND PLACED AT LEAST 12" BEYOND TIE.

ORDERING INFORMATION		
ITEM NO.	RAIL WGT.	DESCRIPTION
014 5250270	115 - 122	CROSSING, CONCRETE PANEL, LIGHT DUTY WITH RUBBER INTERFACE FOR WOOD TIES. ORDER BY TRACK FEET IN APPROX. 8 FT. INCREMENTS.
014 5250275	132 - 136	EACH 8'-1 1/2" SECTION INCLUDES 1 CONCRETE CENTER PANEL WITH RUBBER FLANGEWAY FILLER AND 2 FIELD SIDE RUBBER INTERFACE SECTIONS.
014 5250285	141	



LIGHT DUTY ROAD CROSSING  
CONCRETE AND RUBBER ON WOOD TIES

*J. E. Beyerl*  
APPROVED - VICE PRESIDENT  
ENGINEERING AND MECHANICAL  
STANDARDS AND QUALITY

*James D. Bagley*  
APPROVED - VICE PRESIDENT  
ENGINEERING

PREPARED BY:  
J. E. BEYERL

ISSUED, MAY 22, 1999  
REVISED, MARCH 22, 2005

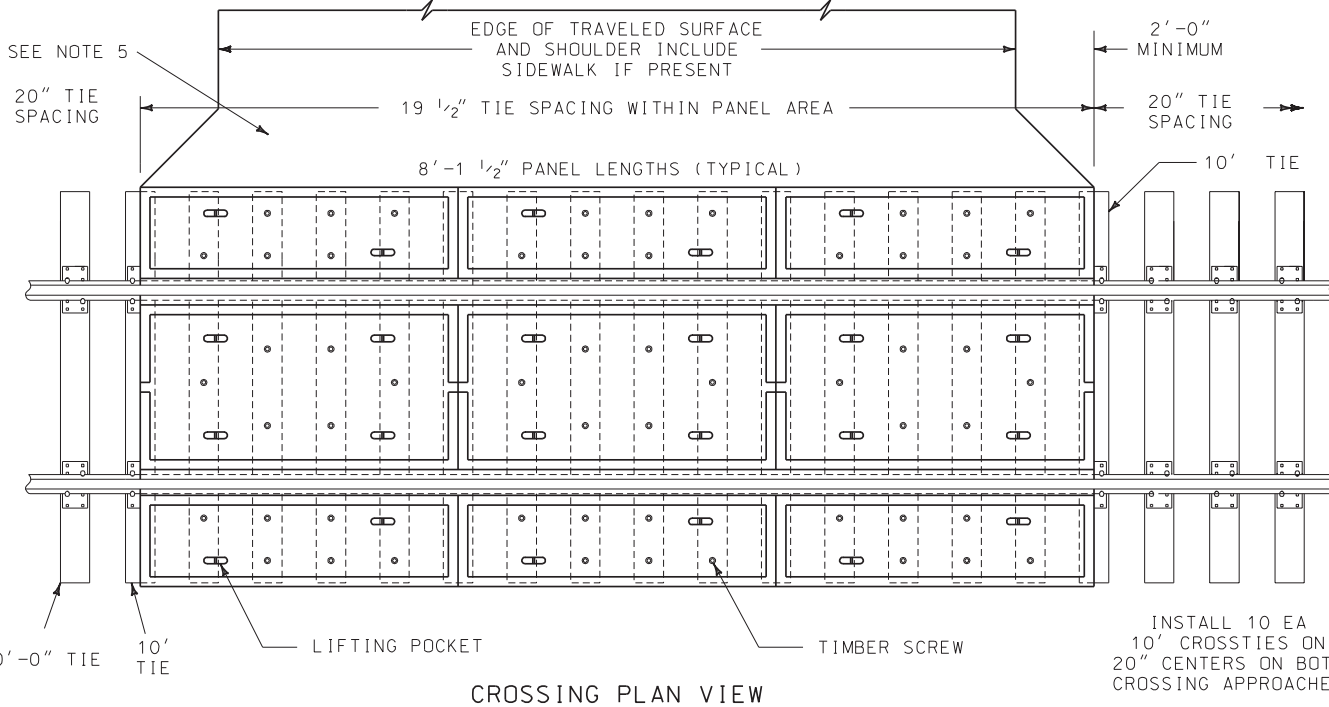

CROSSING PLAN VIEW

NOTES

1. MWI 901 (LASTEST REVISION) IS TO BE USED IN CONJUNCTION WITH THIS DRAWING.
2. FOR NEW CONSTRUCTION, HIGHWAY SHOULD INTERSECT RAILROAD AT OR NEARLY RIGHT ANGLES.
3. FOR NEW CONSTRUCTION, HIGHWAY SURFACE SHOULD NO BE MORE THAN 3 IN. HIGHER OR LOWER THAN TOP OF NEAR RAIL 30 FT. FROM THE RAIL ALONG THE ROAD CENTERLINE, UNLESS TRACK SUPERELEVATION DICTATES OTHERWISE.
4. USE STATE DOT SPECIFICATIONS FOR BITUMINOUS CONCRETE AND SPRAY TACK COAT FOR THE STATE IN WHICH THE CROSSING IS LOCATED.
5. CROSSING SHOULD BE CONTINUOUS BETWEEN ROADWAY OR SIDEWALK EDGES. IF NOT PRACTICABLE, DRAINAGE MUST BE PROVIDED BETWEEN PAVED AREAS TO ELIMINATE WATER POCKETS.
6. SLOPE PAVING TO RETURN TO ORIGINAL PAVEMENT SURFACE. LENGTH OF TRANSITION WILL DEPEND ON LOCAL CONDITIONS. USE A RUNOFF OF 1 IN. PER 10 FT. WHERE PRACTICABLE.
7. IF ROADBED STABILIZATION IS REQUIRED, EXTEND IT 10 FT. BEYOND EDGE OF CROSSING UNDER TRACK.
8. APPROXIMATE WEIGHT FOR 136RE MATERIALS:  
3,200 LBS. - CONCRETE CENTER PANEL  
1,700 LBS. - CONCRETE FIELD PANEL
9. PERFORATED PIPE TO BE SIZED AND LOCATED FOR SITE CONDITIONS. USE 6" MIN. DIA. PIPE AND LOCATE AT LEAST 12" BEYOND END OF TIE.
10. INSTALL 10 EA 10 FT. CROSSTIES EITHER SIDE OF CROSSING. INSTALL 10 FT. CROSSTIES 20" CENTER-TO-CENTER.

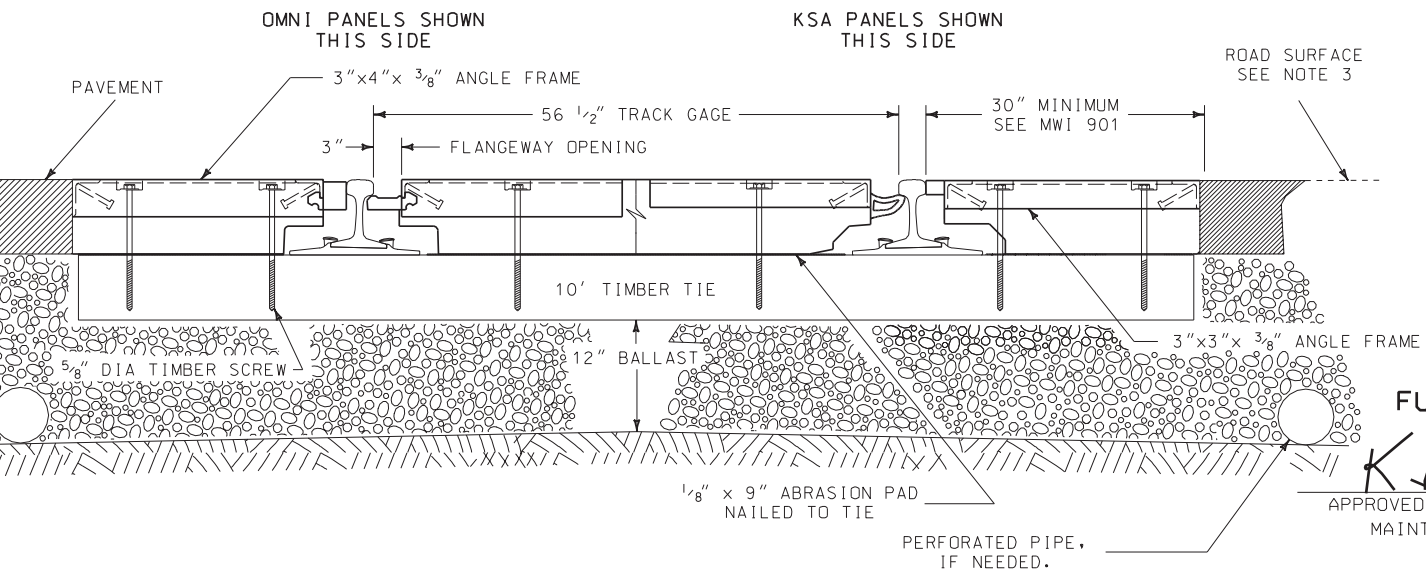

CROSS SECTION

ORDERING INFORMATION		
ITEM NO.	RAIL WGT.	DESCRIPTION
014-5250300	115 - 122	CROSSING, CONCRETE PANELS, HEAVY DUTY, FOR 10 FT. WOOD TIES. ORDER BY "TRACK FEET" IN APPROX. 8 FT. INCREMENTS. EACH 8'-1 1/2" SECTION INCLUDES 1 CONCRETE CENTER AND 2 CONCRETE FIELD PANELS WITH RUBBER FILLERS.
014-5250305	132 - 136	
014-5250310	141	



HEAVY DUTY ROAD CROSSING  
FULL WIDTH CONCRETE ON WOOD TIES

*K A Dawson*  
APPROVED - CHIEF ENGINEER  
MAINTENANCE OF WAY

*James D. Bagley*  
APPROVED - VICE PRESIDENT  
ENGINEERING

PREPARED BY:  
J. E. BEYERL

ISSUED: DECEMBER 12, 2002  
REVISED: DECEMBER 11, 2006

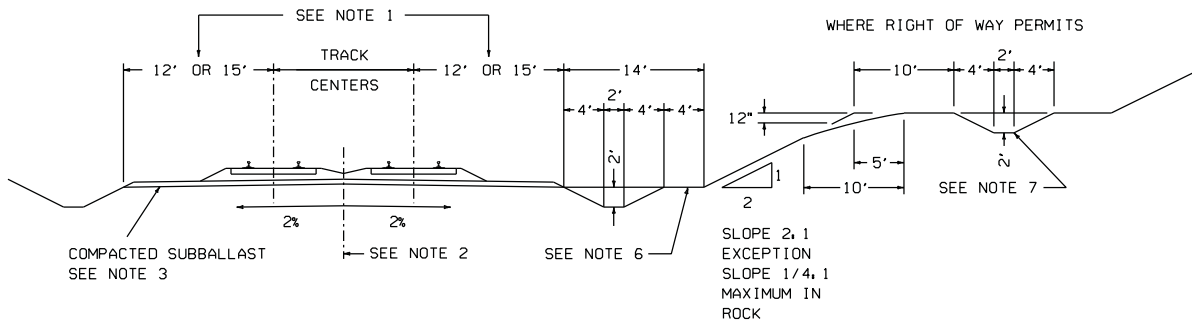

TYPICAL CUT SECTION

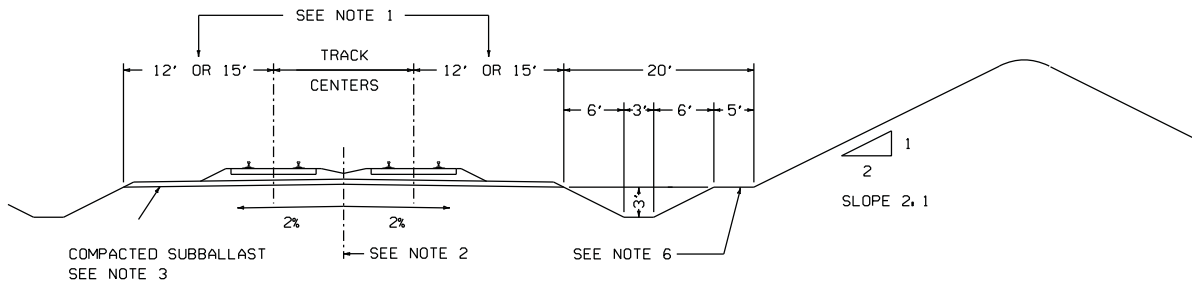

TYPICAL WET CUT SECTION

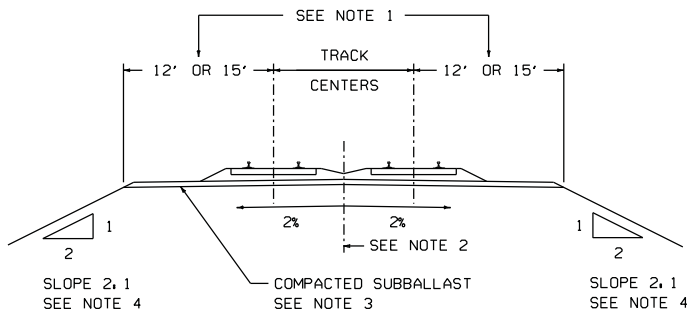

TYPICAL FILL SECTION

NOTES:

1. ROADBED WIDTHS AT TOP OF SUBGRADE.
  - A. SINGLE MAIN TRACKS, SIDINGS, AND HEAVY TONNAGE TRACKS. 15'-0" FROM CENTERLINE OF TRACK, 30'-0" TOTAL
  - B. SINGLE YARD, INDUSTRY, AND OTHER TRACK, 12'-0" FROM CENTERLINE OF TRACK, 24'-0" TOTAL
  - C. MULTIPLE PARALLEL TRACKS. 12'-0" OR 15'-0" FROM CENTERLINE OF TRACK DEPENDING ON THE TYPE OF TRACKS PLUS DISTANCE BETWEEN TRACK CENTERLINES.
2. LOCATION OF GRADE POINT,
  - A. SINGLE MAIN OR OTHER TRACK IS THE CENTERLINE OF TRACK.
  - B. DOUBLE MAIN TRACKS IS THE CENTERLINE BETWEEN TRACKS.
  - C. GRADE POINT FOR MAIN TRACK AND SIDING IS CENTERLINE OF MAIN TRACK.
3. DEPTH OF SUBBALLAST,
  - A. SUBBALLAST ON MAIN TRACKS, SIDINGS AND HEAVY TONNAGE TRACKS IS 6" OVER THE 30' ROADBED WIDTH.
  - B. SUBBALLAST ON YARD, INDUSTRIAL AND OTHER TRACKS IS 4" OVER THE 24' ROADBED WIDTH.
4. THE STANDARD SLOPE ON FILL SECTIONS MAY BE INCREASED TO A MAXIMUM OF 1 1/2 TO 1 AT LOCATIONS WHERE THE BEARING CAPACITY OF THE NATURAL BED HAS BEEN VERIFIED BY FIELD TESTS AND THE STABILITY OF THE FILL MATERIAL VERIFIED BY LABORATORY TESTS.
5. INSTRUCTIONS FOR THE USE AND INSTALLATION OF GEOTEXTILES AND GEOGRIDS ARE INCLUDED IN MWI-1003.
6. OMIT BENCH WHERE EXCAVATION IS 5 FEET OR LESS.
7. OMIT BERM DITCH WHEN NATURAL GROUND SLOPES AWAY FROM THE EXCAVATION.



ROADBED SECTIONS

Signed \_\_\_\_\_  
 REVIEWED -  
 DIRECTOR,  
 STANDARDS AND TESTING

Signed \_\_\_\_\_  
 APPROVED -  
 ASSISTANT VICE PRESIDENT,  
 EQUIPMENT AND TRACK  
 SYSTEMS ENGINEERING

ISSUED, JANUARY 27, 1997

REVISED, INITIAL ISSUE

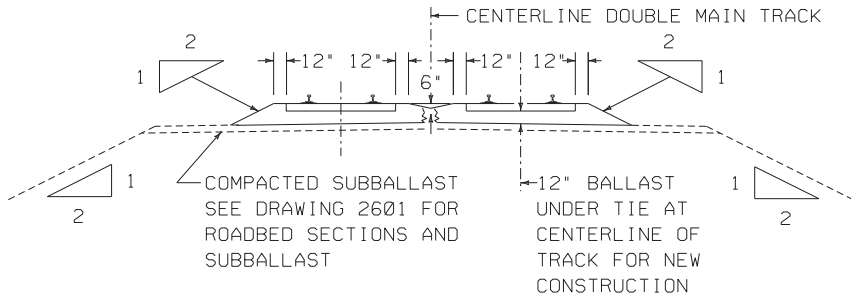

MAIN TRACK, SIDINGS AND HEAVY TONNAGE TRACKS  
TANGENT TRACKS

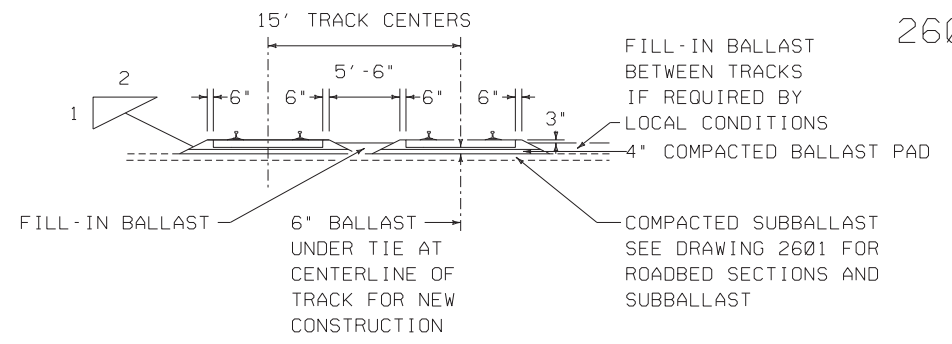

INTERIOR YARD TRACKS

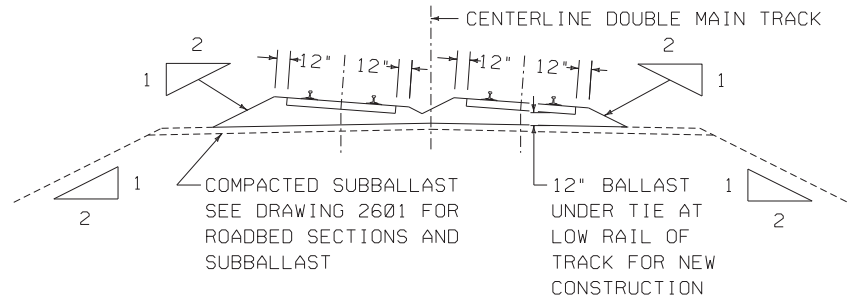

MAIN TRACK, SIDINGS AND HEAVY TONNAGE TRACKS  
SUPERELEVATED TRACKS

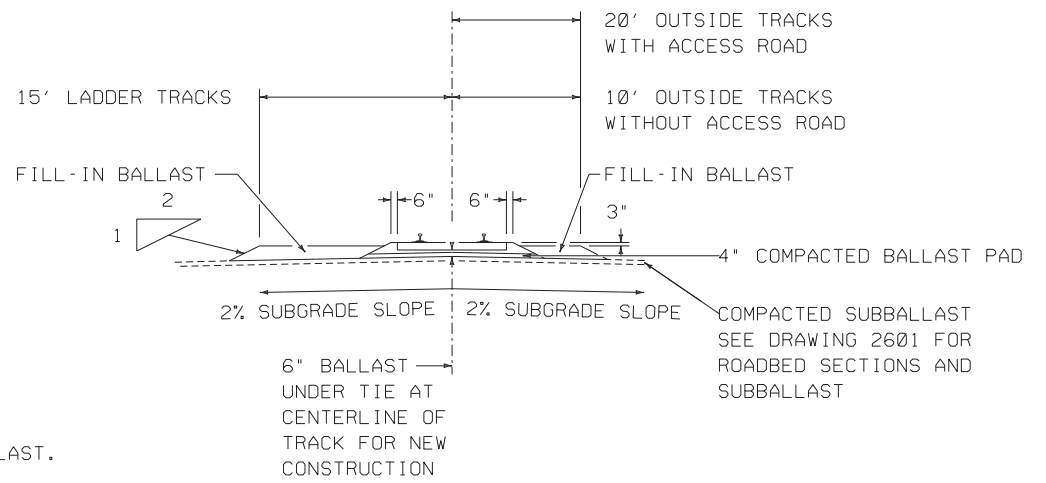

LADDER AND OUTSIDE TRACKS

NOTES.

1. BALLAST TO CONFORM TO THE CURRENT CSXT SPECIFICATION FOR BALLAST.
2. AREMA GRADATION 4A BALLAST IS TO BE USED ON ALL TRACK EXCEPT YARD TRACKS WHERE AREMA GRADATION 5 IS TO BE USED.
3. BALLAST PAD 4" THICK OF AREMA GRADATION 4A WILL BE USED UNDER TRACK FOR NEW CONSTRUCTION OF YARD TRACKS.
4. FILL-IN BALLAST WILL BE AREMA GRADATION 5.
5. BALLAST TO BE EVEN WITH TOP OF TIE.
6. BALLAST SHOULDER WILL EXTEND 12" FROM END OF TIE TO EDGE OF SLOPE ON ALL MAIN TRACKS, SIDING, AND HEAVY TONNAGE TRACKS.
7. BALLAST SHOULDER WILL EXTEND 6" FROM END OF TIE TO EDGE OF SLOPE ON ALL YARD TRACKS AND INDUSTRIAL SIDING TRACKS.



BALLAST SECTIONS

*[Signature]*  
APPROVED - DIRECTOR  
ENGINEERING STANDARDS

*[Signature]*  
APPROVED - VICE PRESIDENT  
ENGINEERING

PREPARED BY,  
D.C. CLARK

ISSUED: JANUARY 27, 1997  
REVISED: AUGUST 3, 2010



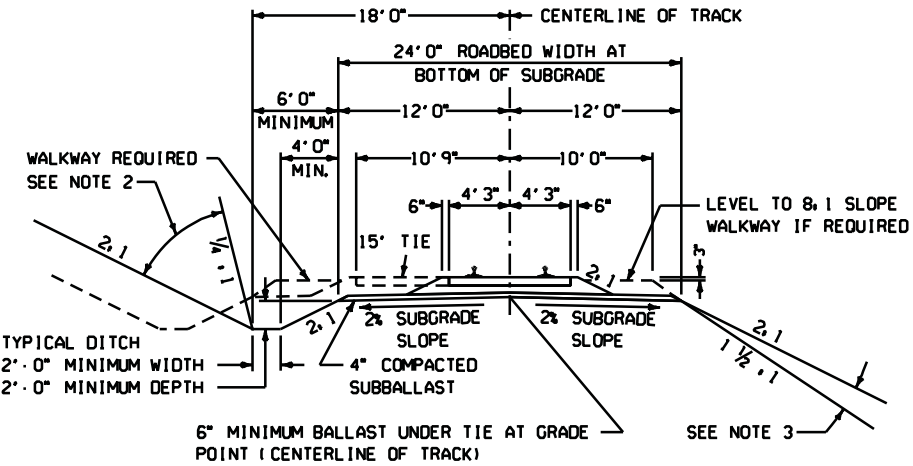
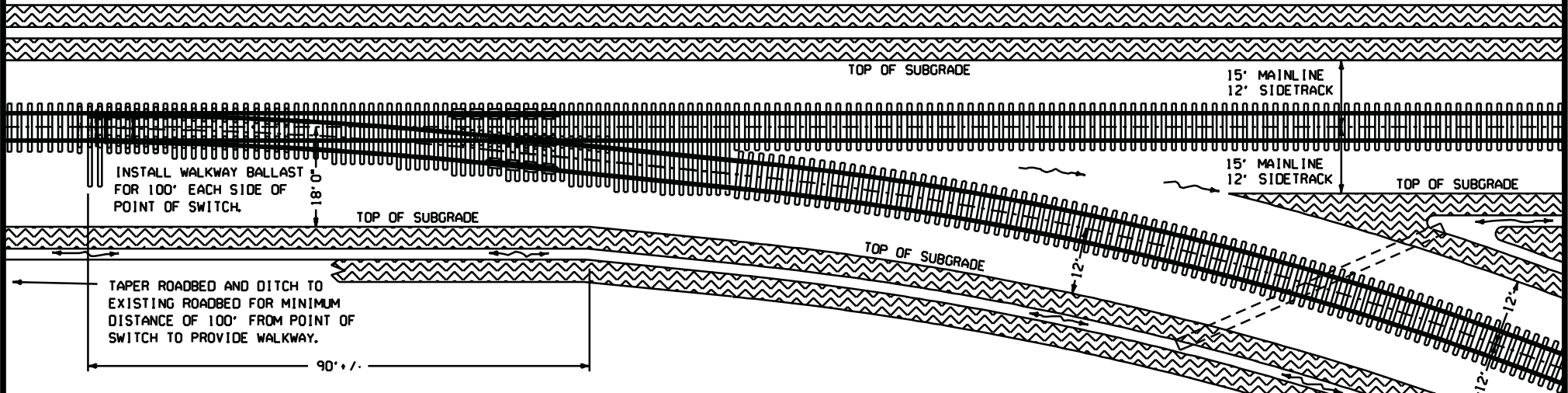

IF TRACK IS SUPERELEVATED, 6" MINIMUM BALLAST REQUIRED UNDER TIE, AT LOW RAIL

**TYPICAL SECTIONS**

**CUT SECTION**      **INDUSTRIAL TRACKS**      **FILL SECTION**

**NOTES:**

- MINIMUM WIDTH OF CUT SECTION AND DITCH WIDTH SHOWN. TRACK AND DITCH GRADIENTS MAY INCREASE DITCH SIZE AND ITS DISTANCE FROM CENTERLINE OF TRACK.
- SLOPE CAN VARY AS NEEDED FOR STABILITY FROM 2:1 IN SAND TO 1/4 : 1 IN SOLID ROCK
- SLOPE AS REQUIRED BY FILL MATERIAL. 1 1/2 : 1 MAXIMUM.
- GEOTEXTILES, IF USED, SHALL BE PLACED BETWEEN THE TOP OF THE SUBGRADE AND THE BOTTOM OF THE SUBBALLAST

**NOTES, CONTINUED**

- MINIMUM PIPE DIAMETER IS 24".
- LENGTH OF PIPE UNDER SIDE TRACK IS DEPENDANT ON DEPTH BELOW BOTTOM OF TIE (2' MINIMUM).
- LOCATION, ANGLE TO TRACK, AND GRADE OF PIPE DEPENDANT ON DRAINAGE CONDITIONS AT SITE. PIPE TO BE LOCATED AND INSTALLED TO MAINTAIN EXISTING DRAINAGE OR TO DIVERT RUNOFF TO ANOTHER FACILITY THAT WILL ACCEPT IT.



**ROADBED SECTIONS AND GRADING FOR INDUSTRIAL TRACK TURNOUTS**

SIGNED	SIGNED
REVIEWED - DIRECTOR, STANDARDS AND TESTING	APPROVED - ASSISTANT VICE PRESIDENT, EQUIPMENT AND TRACK SYSTEMS ENGINEERING
ISSUED, JANUARY 27, 1997	REVISED, INITIAL ISSUE

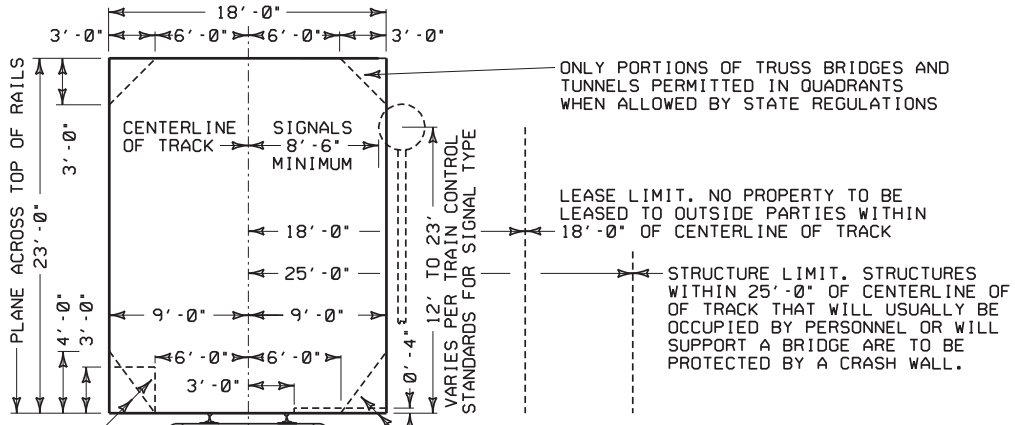

1. STANDARD CLEARANCES ARE TO BE USED FOR ALL NEW CONSTRUCTION WHERE THERE ARE NO LEGAL REQUIREMENTS THAT DICTATE GREATER CLEARANCES.
2. CLEARANCES FOR RECONSTRUCTION, REHABILITATION AND ALTERATION WORK ARE DEPENDENT ON EXISTING PHYSICAL CONDITIONS. WHERE POSSIBLE, THEY WILL BE IMPROVED TO COMPLY WITH THE STANDARD CLEARANCES.
3. STATE OR CANADIAN CLEARANCE LAWS MUST NOT BE VIOLATED. LEGAL REQUIREMENTS MAY BE MODIFIED ONLY BY THE GOVERNMENTAL BODY THAT ISSUED THEM.
4. STANDARD CLEARANCE MAY BE MODIFIED ONLY IF APPROVED BY THE CHIEF ENGINEER DESIGN, CONSTRUCTION, AND CAPACITY.
5. STANDARD CLEARANCE DIAGRAMS SHOWN ARE FOR TANGENT TRACK AND INCREASES MUST BE PROVIDED FOR THE EFFECTS OF CURVATURE AND SUPERELEVATION.

A. ADDITIONAL CLEARANCE DUE TO CURVATURE:

WHEN A FIXED OBSTRUCTION IS LOCATED ADJACENT TO A CURVED TRACK, THE HORIZONTAL CLEARANCE WILL BE INCREASED 1 1/2 INCHES PER DEGREE OF CURVATURE ON BOTH SIDES OF THE TRACK CENTERLINE PER TABLE 1. EXCEPTION: FLORIDA REQUIRES 2 INCHES PER DEGREE.

B. ADDITIONAL CLEARANCE DUE TO SUPERELEVATION:

WHEN A FIXED OBSTRUCTION IS LOCATED ADJACENT TO A SUPERELEVATED TRACK, THE HORIZONTAL CLEARANCE ON THE LOW RAIL SIDE OF THE TRACK WILL BE INCREASED TO ALLOW FOR TILT. THE MINIMUM INCREASE IS SHOWN ON GRAPH NO. 1.

C. ADDITIONAL CLEARANCE DUE TO CURVATURE AND SUPERELEVATION:

WHEN A FIXED OBSTRUCTION IS LOCATED ADJACENT TO A CURVED AND SUPERELEVATED TRACK, THE HORIZONTAL CLEARANCE INCREASE WILL BE THE SUM OF THE INCREASES OBTAINED USING 5.A AND 5.B ABOVE. EXCEPTION: CANADA REQUIRES A MINIMUM OF 2 INCHES PER DEGREE.

D. ADDITIONAL CLEARANCE ON TANGENT TRACKS:

WHEN A FIXED OBSTRUCTION IS ADJACENT TO TANGENT TRACK BUT THE TRACK IS CURVED WITHIN 80 FEET OF THE OBSTRUCTION, THE HORIZONTAL CLEARANCE WILL BE INCREASED AS FOLLOWS:

DISTANCE FROM OBSTRUCTION TO CURVED TRACK - FEET	INCREASED HORIZONTAL CLEARANCE
0 TO 20	100% OF PARAGRAPH 5.C
21 TO 40	75% OF PARAGRAPH 5.C
41 TO 60	50% OF PARAGRAPH 5.C
61 TO 80	25% OF PARAGRAPH 5.C

6. VERTICAL CLEARANCE ON SUPERELEVATED TRACK IS MEASURED FROM THE TOP OF THE HIGH RAIL.

GRAPH NUMBER 1  
DIAGONAL LINES INDICATE SUPERELEVATION

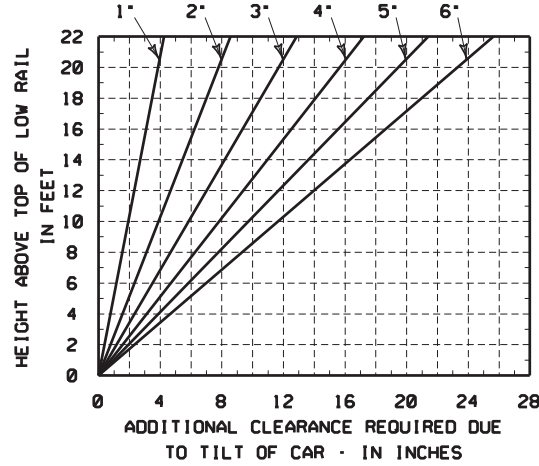

GENERAL  
MAIN TRACKS, YARD TRACKS AND SIDINGS

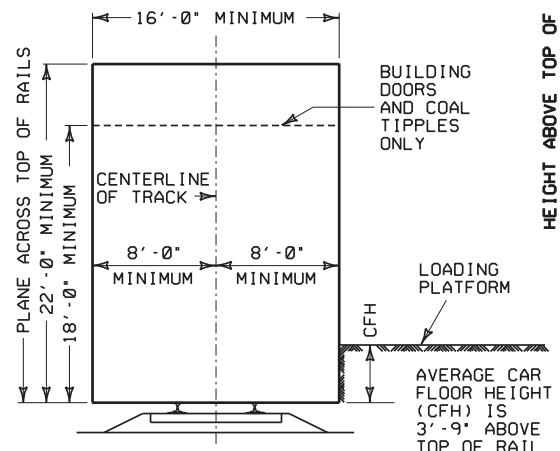

INDUSTRIAL SIDE TRACKS

TABLE NUMBER 1

ADDITIONAL CLEARANCE REQUIRED DUE TO CURVATURE - IN INCHES												
DEGREE OF CURVE	1	2	3	4	5	6	7	8	9	10	11	12
ALL LOCATIONS EXCEPT FLORIDA	1 1/2	3	4 1/2	6	7 1/2	9	10 1/2	12	13 1/2	15	16 1/2	18
IN THE STATE OF FLORIDA	2	4	6	8	10	12	14	16	18	20	22	24



CLEARANCE DIAGRAMS

*Wab W. Ophardt*  
APPROVED - CHIEF ENGINEER  
DESIGN, CONSTRUCTION, & CAPACITY

*James D. Bagley*  
APPROVED - VICE PRESIDENT  
ENGINEERING

**DIMENSIONS - NOTES:**

ARE SHOWN IN FEET AND INCHES (FT-IN).  
 ARE FOR TANGENT TRACK. SEE CSX 2604 FOR INCREASE DUE TO CURVATURE.  
 VERTICAL CLEARANCE IS MEASURED FROM TOP OF HIGH RAIL FOR THE ENTIRE FULL HORIZONTAL WIDTH DESCRIBED BELOW.  
 HORIZONTAL CLEARANCE IS MEASURED FROM CENTERLINE OF NEAREST TRACK.  
 APPLY TO ALL NEW CONSTRUCTION, RECONSTRUCTION AND ALTERATIONS  
 ALL COLUMNS ARE MINIMUM EXCEPT COLUMNS 22, 24, 27, AND 29 WHICH ARE MAXIMUM  
 CFH = CAR FLOOR HEIGHT.  
 REFERENCE CHAPTER 28 OF AREMA MANUAL FOR RAILWAY ENGINEERING FOR ENTIRE DETAILS OF STATE LEGAL CLEARANCES

TRACK CENTERS								
MAIN TRACKS	ANY TWO NON-MAIN TRACKS	ADJACENT NON-MAIN TRACK TO ANY MAIN TRACK	LADDER TRACK ADJACENT TO ANY PARALLEL TRACK	TWO ADJACENT PARALLEL LADDER TRACKS	LADDER TRACKS AND CABOOSE TRACKS	TEAM TRACKS IN PAIRS	UNLOADING TRACKS AT PLATFORMS	MAIN TRACK AND BULK LOADING OR UNLOADING TRACK
1	2	3	4	5	6	7	8	9
15-0	14-0	20-0	20-0	19-0	14-0	13-6	13-6	20-0

VERTICAL						HORIZONTAL					
GENERAL (UNLESS PROVIDED FOR)	THRU BRIDGES	HIGHWAY BRIDGE (SPANNING TRACKS)	TUNNELS	BUILDING DOORS	IN BUILDINGS	GENERAL (UNLESS PROVIDED FOR)	THRU BRIDGES	HIGHWAY BRIDGE (SPANNING TRACKS)	TUNNELS	BUILDING DOORS	IN BUILDINGS
10	11	12	13	14	15	16	17	18	19	20	21
23-0	23-0	23-0	23-0	18-0	22-0	9-0	9-0	25-0	9-0	8-0	8-0

**EXCEPTIONS:**  
 COLUMN 6 SHALL BE 17-0 IN MASSACHUSETTS  
 COLUMN 7 AND 8 SHALL BE 14-0 IN MICHIGAN  
 COLUMN 14 SHALL BE 21-0 IN OHIO; 22-0 IN INDIANA, WEST VIRGINIA, & CANADA; 22-6 IN CONNECTICUT, MASSACHUSETTS, & MICHIGAN  
 COLUMN 15 SHALL BE 22-6 IN CONNECTICUT, MASSACHUSETTS, & MICHIGAN; 23-0 IN DELAWARE  
 COLUMN 16 SHALL BE 12-0 IN PENNSYLVANIA  
 COLUMN 20 SHALL BE 8-6 IN MASSACHUSETTS AND MICHIGAN  
 COLUMN 21 SHALL BE 8-6 IN MICHIGAN

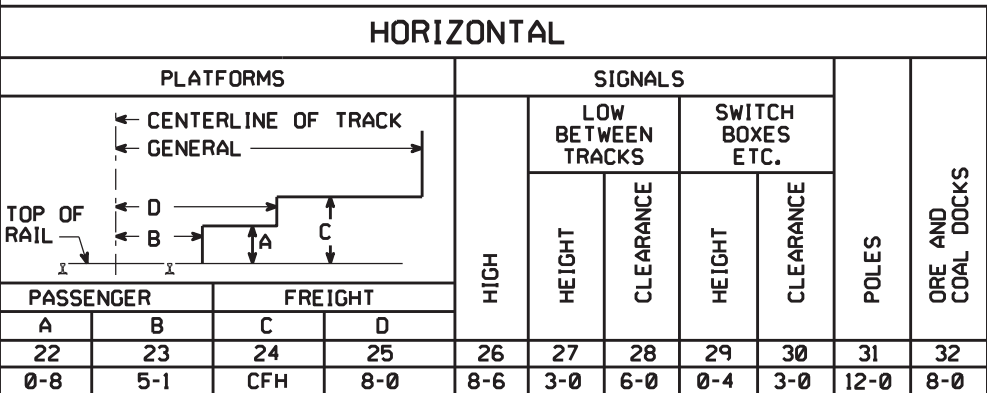

**EXCEPTIONS:**  
 COLUMN 22 SHALL BE 0-4 IN ILLINOIS  
 COLUMN 23 SHALL BE 5-2 IN CONNECTICUT  
 COLUMN 25 SHALL BE 8-6 IN CONNECTICUT, MARYLAND, MICHIGAN, NEW YORK, & PENNSYLVANIA  
 COLUMN 26 SHALL BE 9-0 IN DELAWARE; 12-0 IN PENNSYLVANIA  
 COLUMN 27 SHALL BE 4-0 IN CANADA  
 COLUMN 29 SHALL BE 0-5 IN CANADA  
 COLUMN 30 SHALL BE 3-10 IN CANADA  
 COLUMN 32 SHALL BE 8-4 1/4 IN CANADA; 8-6 IN DC, & MARYLAND



**STANDARD CLEARANCE MATRIX**

*[Signature]*  
 APPROVED - DIRECTOR  
 ENGINEERING STANDARDS

*[Signature]*  
 APPROVED CHIEF ENGINEER -  
 ENGINEERING SERVICES

PREPARED BY:  
 C.S. MOALE

ISSUED: JULY 19, 1996  
 REVISED: NOVEMBER 12, 2014

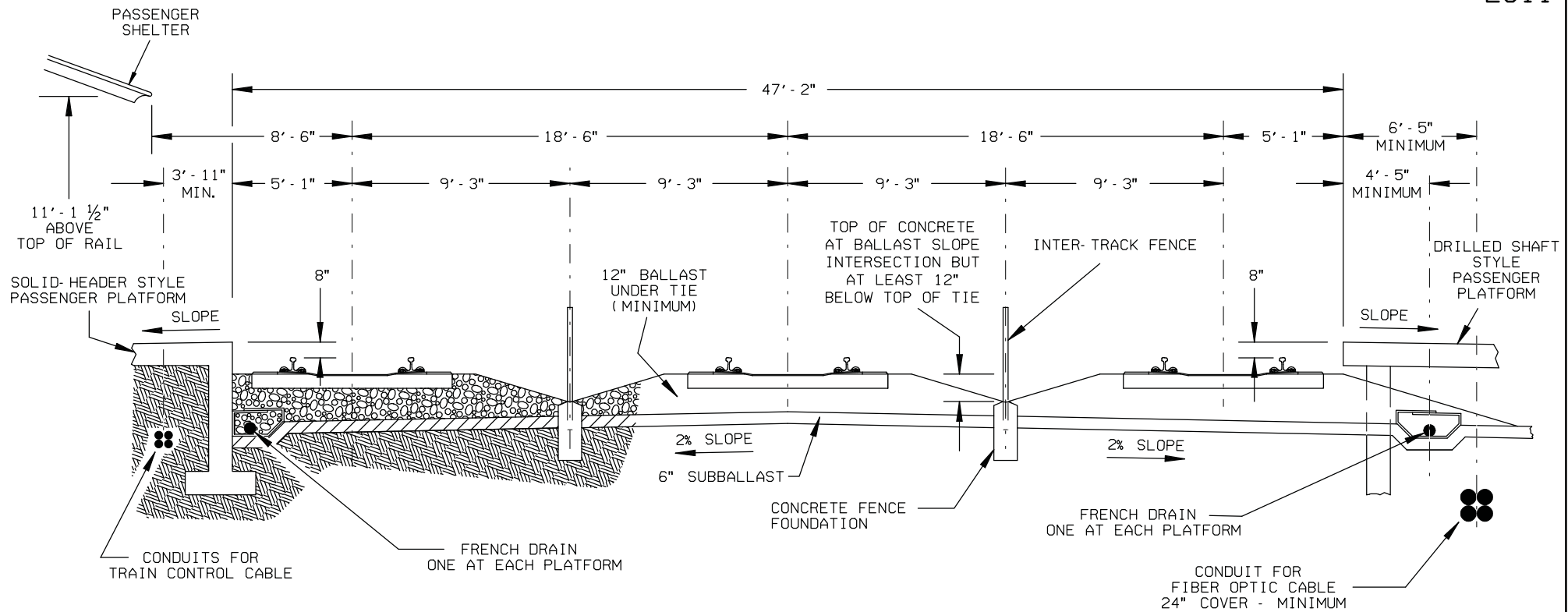

STATION LIGHTING SHALL BE DESIGNED IN A MANNER TO ENSURE THAT IT DOES NOT INTERFERE WITH TRAIN CONTROL SIGNALS.

TRAIN CONTROL CONDUITS - USE 4 EACH 4" SCHEDULE 40 PIPES WITH PULL WIRES. EXTEND 36" BEYOND PLATFORM AND CAP.

FRENCH DRAINS - USE 6" PERFORATED DRAINAGE PIPE, EITHER POLYETHYLENE OR CORRUGATED METAL. WRAP BALLAST AND PIPE WITH 6 OZ NONWOVEN GEOTEXTILE.

FIBER OPTIC CABLE CONDUIT - USE 4 EACH 8" HDPE - HDR11 OR STEEL CONDUIT WITH MINIMUM 0.388" WALL THICKNESS. EXTEND 36" BEYOND PLATFORM AND CAP.

INTER-TRACK FENCE - 4'-0" TALL, 6" WIDE MAX. REMOVABLE, FENCE PANELS SHALL EXTEND A MINIMUM OF 100' BEYOND ENDS OF LONGEST PLATFORM OR TO A POINT WHERE OTHER ELEMENTS RESTRICT PEDESTRIAN MOVEMENT ACROSS TRACKS.

CONCRETE TIES WITH ELASTIC FASTENERS SHALL EXTEND A MINIMUM OF 150' BEYOND THE PLATFORMS. IN WOOD TIE TERRITORY, THE TRANSITION ZONE SHALL NOT BE IN A CURVE. WOOD TIES WITH APPROPRIATE FASTENERS MAY BE USED IF THE TRACK CENTERS ARE INCREASED TO 20 FEET OR GREATER.

CLEARANCES SHOWN ARE BASED ON STRAIGHT AND LEVEL TRACK. IF ACTUAL CONDITIONS DIFFER, CLEARANCES MUST BE REVIEWED. STATE OR CANADIAN CLEARANCE LAWS MUST NOT BE VIOLATED. SEE CSXT DRAWING 2605.

PEDESTRIAN CROSSINGS ARE TO BE GRADE SEPARATED.



## GENERAL ARRANGEMENT AT PASSENGER PLATFORMS

SIGNED

REVIEWED - DIRECTOR  
ENGINEERING STANDARDS

PREPARED BY:  
D. N. WITT

SIGNED

APPROVED - CHIEF ENGINEER  
MAINTENANCE OF WAY

ISSUED, FEBRUARY 28, 2002  
REVISED, INITIAL ISSUE

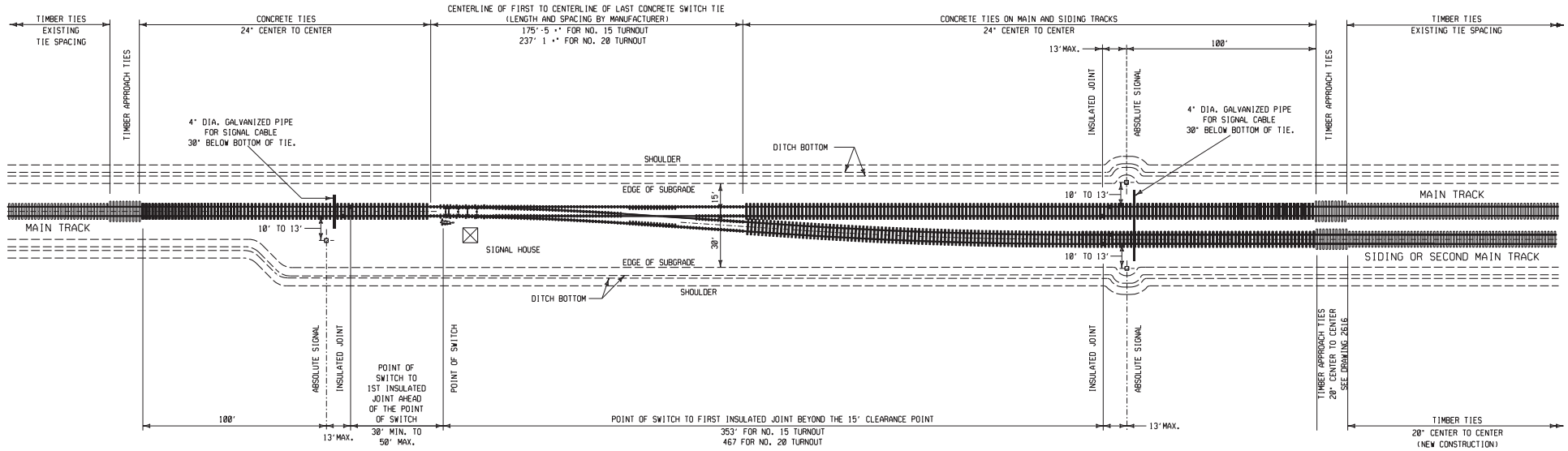

NOTES:

- TIMBER TRANSITION TIES WITH PANDROL TIE PLATES AND FASTNERS AT 20' TIMBER TIE SPACING 10 EACH 10'-0" TIES. SEE STANDARD DRAWING 2616.
- TIMBER TO CONCRETE TIE TRANSITIONS SHOULD BE AVOIDED IN CURVES.
- UNDERLAYMENT (WHERE REQUIRED) -  
 USE 6" HOT MIX ASPHALT UNDERLAYMENT.  
 COLD MIX MAY BE SUBSTITUTED, IF HOT MIX IS NOT AVAILABLE.
- WINTER SWITCH PROTECTION -  
 SEE MWI 608 FOR APPROPRIATE USAGE.  
 ELECTRIC RESISTANCE SWITCH HEATERS ARE SHOWN ON STANDARD DRAWINGS 2330 AND 2331.  
 HOT AIR BLOWER SWITCH HEATERS ARE SHOWN ON STABDARD DRAWING 2332.
- SEE DRAWING SS515 AND SS516 FOR EXACT PLACEMENT OF SIGNAL EQUIPMENT.
- TRACK BALLAST -  
 USE 12" OF MAIN LINE BALLAST THROUGHOUT.

**CSX** TRANSPORTATION

GENERAL ARRANGEMENT  
 AT END OF SIDINGS AND DOUBLE TRACK

*K.A. Donald*  
 APPROVED - CHIEF ENGINEER  
 MAINTENANCE OF WAY

*James D. Bayley*  
 APPROVED - VICE PRESIDENT  
 ENGINEERING

PREPARED BY:  
 D.C. CLARK

ISSUED: APRIL 30, 2003  
 REVISED: APRIL 11, 2007



PURPOSE:	To provide uniform instructions for anchoring the track structure.
SAFETY:	Observe all applicable Safety, and Operating Rules and Regulations; and Safe Job Procedures
LOCATION:	All CSXT tracks.
ENVIRONMENTAL:	Observe all applicable Federal, State and Local environmental rules and regulations.

## **I. DISCUSSION**

- A. Rail anchors are essential in achieving a stable track structure. They are designed to prevent longitudinal movement of the rail and work together with the other components of the track structure to prevent buckling.
- B. Rail anchors are required on both jointed and continuously welded rail tracks. They will be applied before the track is returned to service.
- C. All tracks, which are not in compliance with this rail anchoring policy, will be brought up to standard during the next System Team Rail Laying, Curve Patch, or Bridge Timbering operation. During System Timbering operations, missing anchors will be replaced to match the pattern currently in track. Tracks, that have a history of buckling or excessive rail movement, will be reviewed by the Division Engineer on a case-by-case basis to establish a date for compliance. If the next System Team cycle is too far away, a schedule for compliance will be prepared by the Division Engineer and approved by the Chief Engineer - Maintenance of Way.
- D. New rail anchors will be manufactured from mill certified steel.
- E. Relay rail anchors will not be used on main tracks or passing sidings when laying new rail by system rail teams. Rail anchors removed to perform other maintenance activities may be reinstalled if effective.

## II. PROCEDURE

### A. All Track

1. To avoid tie skewing, anchors should be applied against the same tie on opposite rails.  
(Opposite rails should be anchored the same)
2. Definition: Box Anchor – Anchors applied against both sides of the tie on opposite rails to restrain longitudinal rail movement in both directions. [Four (4) rail anchors per tie.]

### B. Jointed Rail Territory

The track will have 16 rail anchors per 39 ft. rail. Box anchor 8 ties per rail length spaced in accordance with Rail Anchor Pattern Sketch shown on page 5, where practical.

### C. Continuous Welded Rail Territory

1. Definition: Continuous Welded Rail (CWR) – A number of rails welded together into lengths exceeding 400 feet.
2. When laying continuous welded rail (CWR), it will be box anchored on every other tie throughout the entire section of CWR. Additional rail anchors are required at the following locations:
  - a. Joints installed in CWR will be box anchored on every tie for 130 consecutive ties in each direction within 60 days except ties supporting rail joints.
  - b. Curves 3 degrees and greater on main track and sidings – CWR being installed will be anchored on every tie. (Anchors applied against both sides of each tie.)
  - c. Turnouts - CWR will be box anchored on every tie for 130 consecutive ties in each direction from the long ties of the turnout.
  - d. Railroad Crossings - CWR will be box anchored on every tie for 130 consecutive ties in each direction from the railroad crossing.
  - e. Road Crossings - CWR will not be anchored within the road crossing unless required by the design of the road crossing surface material. If the road crossing is 50 ft. wide or greater, CWR will be box anchored on every tie for 130 consecutive ties in each direction from the road crossing.
  - f. All Open Deck Bridge Approaches - CWR will be box anchored on every tie for 130 consecutive ties in each direction from the backwall of the bridge.
  - g. Epoxy Bonded Insulated Joints - Structurally sound epoxy bonded insulated joints do not require additional anchors.
3. CWR laid across bridges will be anchored as follows:
  - a. Ballast Deck Bridges - CWR will use the standard anchor pattern as described in paragraph II.C.2.

- b. Open Deck Bridges with total length 100 ft or less - CWR will be box anchored on every tie that is fastened to the bridge span.
  - c. Open Deck Bridges with total length between 100 ft. and 500 ft. with an alignment of 2 degrees or less:
    - 1) CWR will be box anchored on every tie that is fastened to the bridge span, throughout all spans less than 100 ft.
    - 2) CWR will be box anchored on every tie that is fastened to the bridge span, for the first 100 ft. from the fixed end of individual spans with length greater than 100 ft.
  - d. Rail anchor pattern will be specified by the Asst. Chief Engineer – Structures when any of the following conditions exist:
    - 1) Open Deck Bridges with a total length greater than 500 feet
    - 2) Alignment is greater than 2 degrees
    - 3) Bridges with existing rail expansion joints
    - 4) Other special situations
4. Turnouts within CWR territory will have every tie box anchored, where anchors can be applied, on both the straight side and diverging side of the turnout. Care must be taken to ensure that anchors do not interfere with the movable portion of the switch. Ensure that the requirements in paragraph II.C.2.d. are met. Ties with positive restraint rail fasteners are considered to be anchored.
5. Ties that have a positive restraint fastener on one end only should be box anchored on the other end. MWI 701, *Use of Premium Rail Fasteners in CWR*, details the use of these fasteners.
6. At some locations, there may be two or more of the above situations present. In that case the requirements will be additive.
- For example: A turnout located 100 ft. from an open deck bridge (75 ft. long). In this example, the CWR will be box anchored on every tie between the backwall at the end of the bridge and the turnout. The turnout will be box anchored on every tie, where anchors can be applied, on both the straight side and diverging side of the turnout. The CWR will be box anchored on every tie for 130 ties beyond long ties of the turnout.
7. Rail Anchor Patterns are illustrated on attached plans.



Prepared by: Mark E. Austin  
Engineer Standards II

Reviewed:   
Director – Engineering Standards

Approved:   
Assistant Vice President – Engineering

Office of the Vice President, Engineering  
Jacksonville, Florida

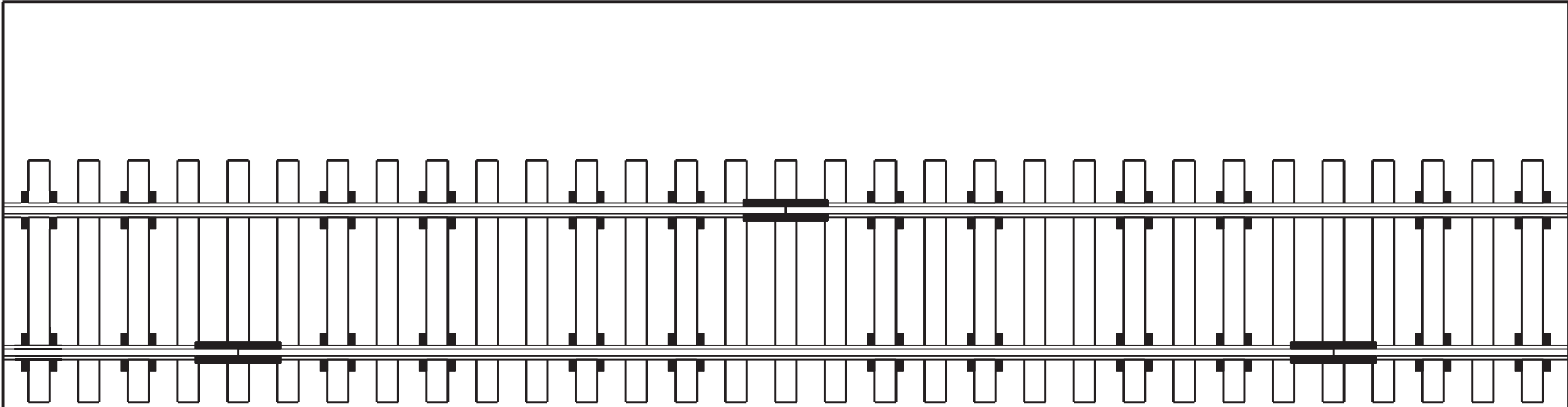

JOINTED RAIL - 16 ANCHORS PER 39 FOOT RAIL, BOX ANCHOR 8 TIES.

**RAIL ANCHOR PATTERNS**

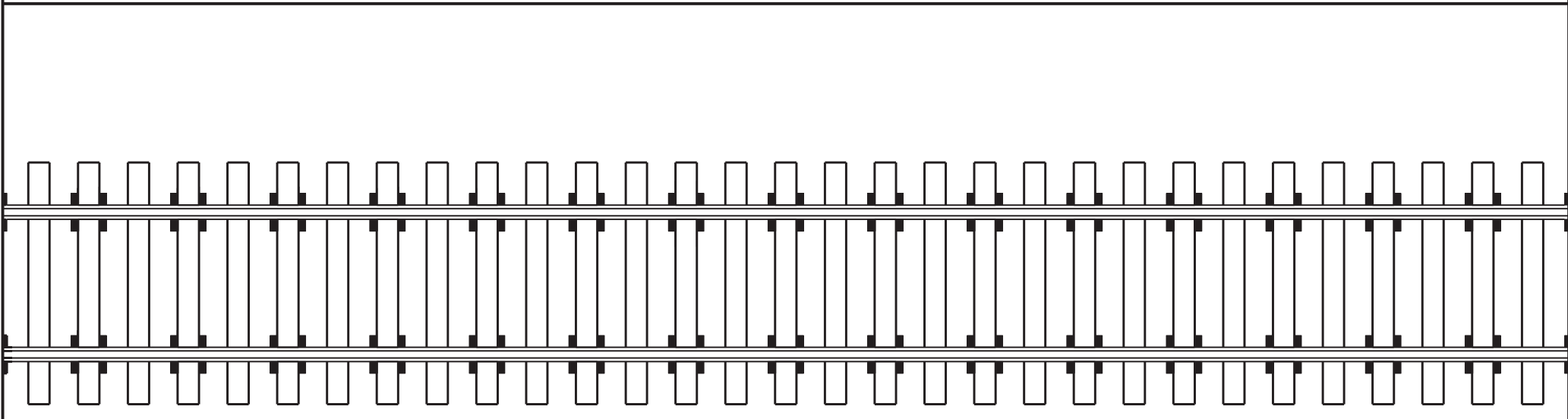

WELDED RAIL - TANGENTS AND CURVES LESS THAN 3 DEGREES - BOX ANCHOR EVERY OTHER TIE.  
 SAME PATTERN FOR BALLAST DECK BRIDGES.

**RAIL ANCHOR PATTERNS**

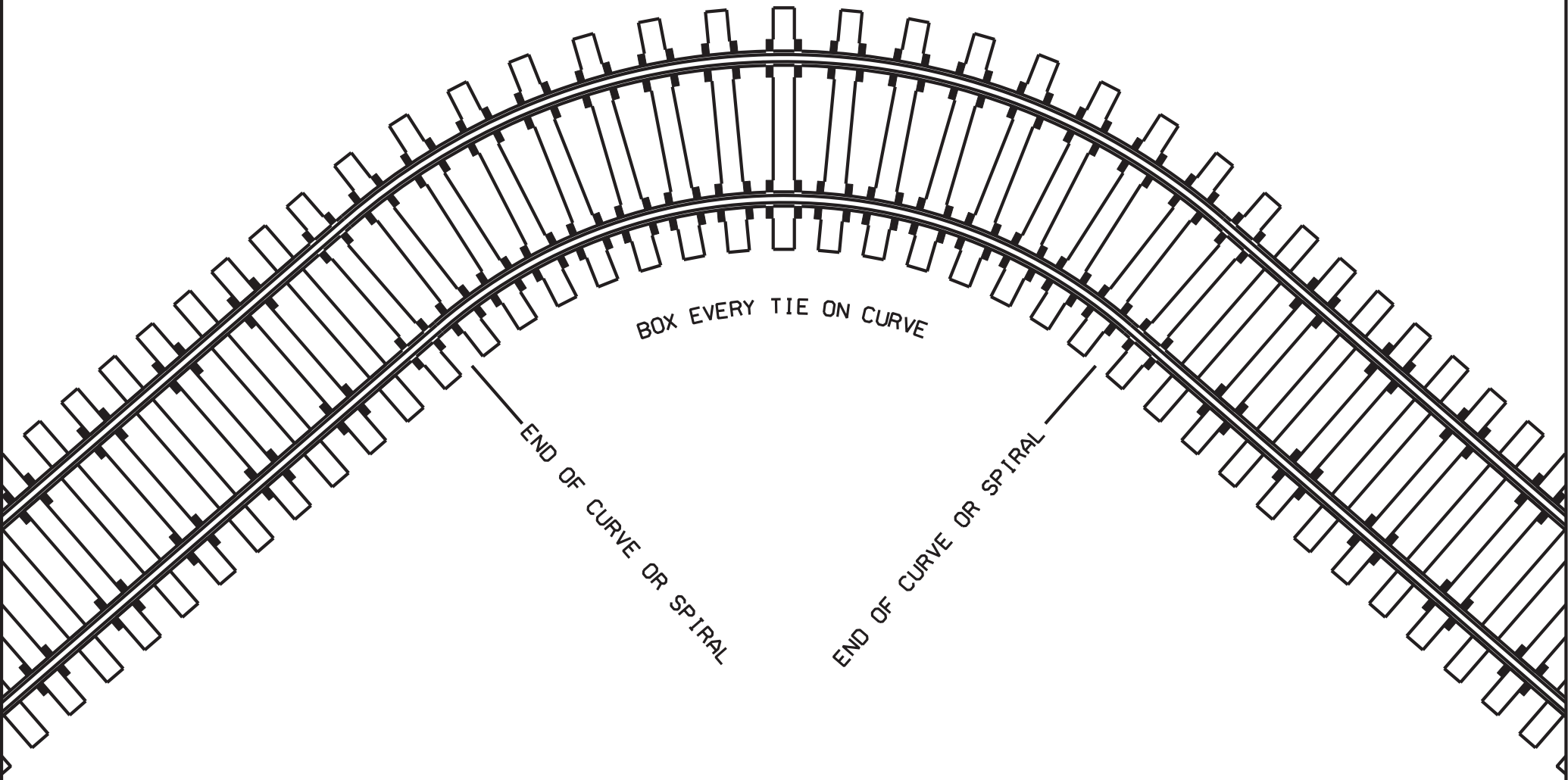

WELDED RAIL - CURVES, 3 DEGREES AND GREATER  
BOX ANCHOR EVERY TIE ON CURVE AND SPIRALS  
**RAIL ANCHOR PATTERNS**

**AHEAD OF SWITCH POINT :**

- BOX ANCHOR EVERY TIE FOR 130 TIES. COUNT FROM FURTHEST JOINT FROM SWITCH POINT OR FROM TIE AHEAD OF BRACE PLATES IF STOCK RAILS ARE WELDED INTO TRACK.
- IF JOINT BARS ARE PERMANENT, DO NOT APPLY ANCHORS OPPOSITE BARS

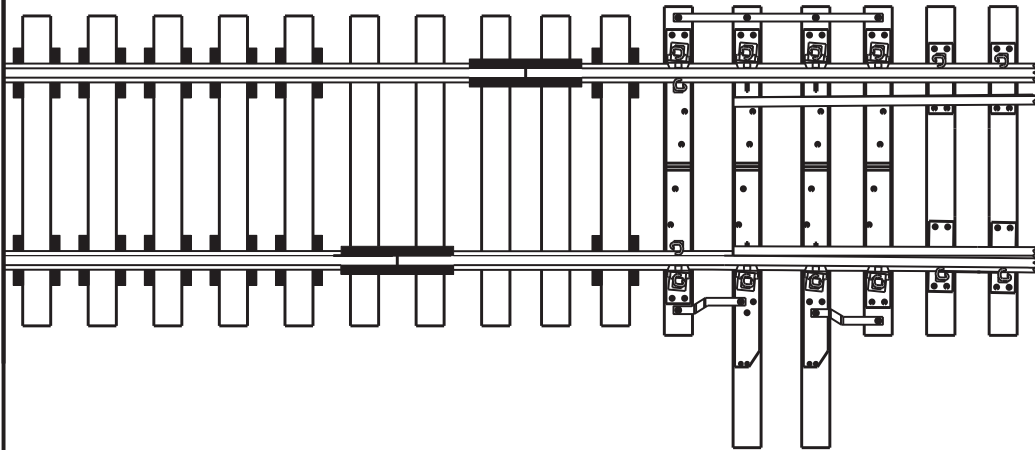

**BEHIND HEEL OF FROG :**

- BOX ANCHOR EVERY TIE FOR 130 TIES ON BOTH THE THROUGH TRACK AND TURNOUT TRACK. COUNT FROM THE LAST LONG TIE.
- BOX ANCHOR EVERY TIE TO END OF GUARD RAIL.

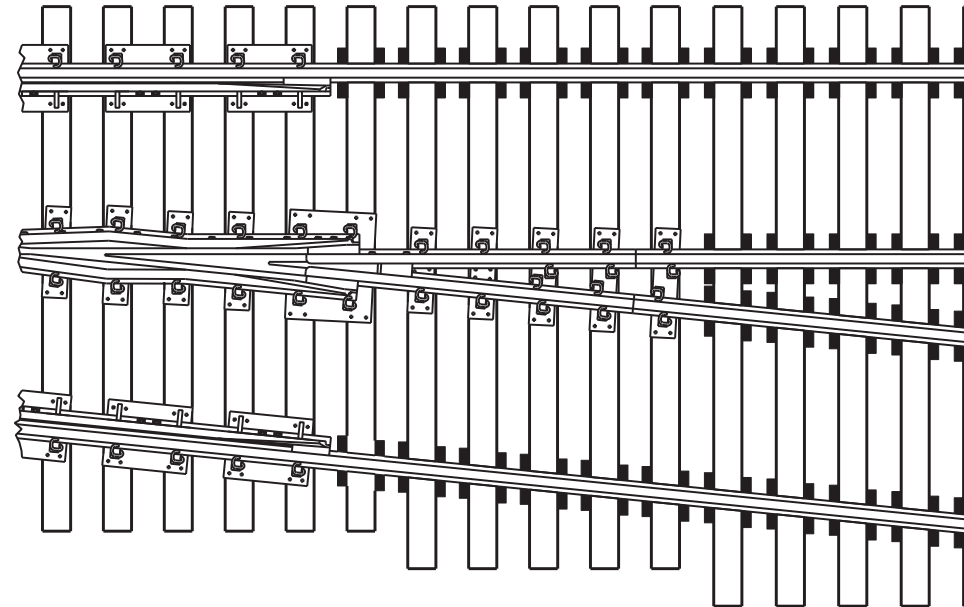

- BETWEEN SWITCH HEEL AND TOE OF FROG, BOX ANCHOR EVERY TIE THAT CAN BE ANCHORED ON AS MANY RAILS AS POSSIBLE. (REFER TO APPLICABLE STANDARD DRAWINGS)

**WELDED RAIL ANCHOR PATTERN ADDITIONS**

**BOTH SIDES OF RAIL JOINTS :**

- BOX ANCHOR EVERY TIE FOR 130 TIES.
- USE NORMAL ANCHOR PATTERN FOR :**
- EPOXY GLUED INSULATED JOINTS.
  - JOINTS WHICH ARE TO BE WELDED AS THE RAIL IS BEING LAID OR IMMEDIATELY AFTER IT IS LAID.

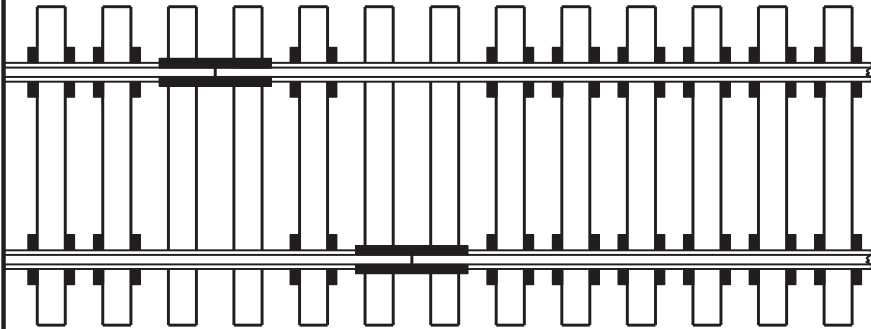

**BOTH APPROACHES TO :**

- ALL RAILROAD CROSSINGS. BOX ANCHOR EVERY TIE FOR 130 TIES. COUNT FROM FIRST TIE BACK FROM CROSSING THAT CAN BE BOX ANCHORED.

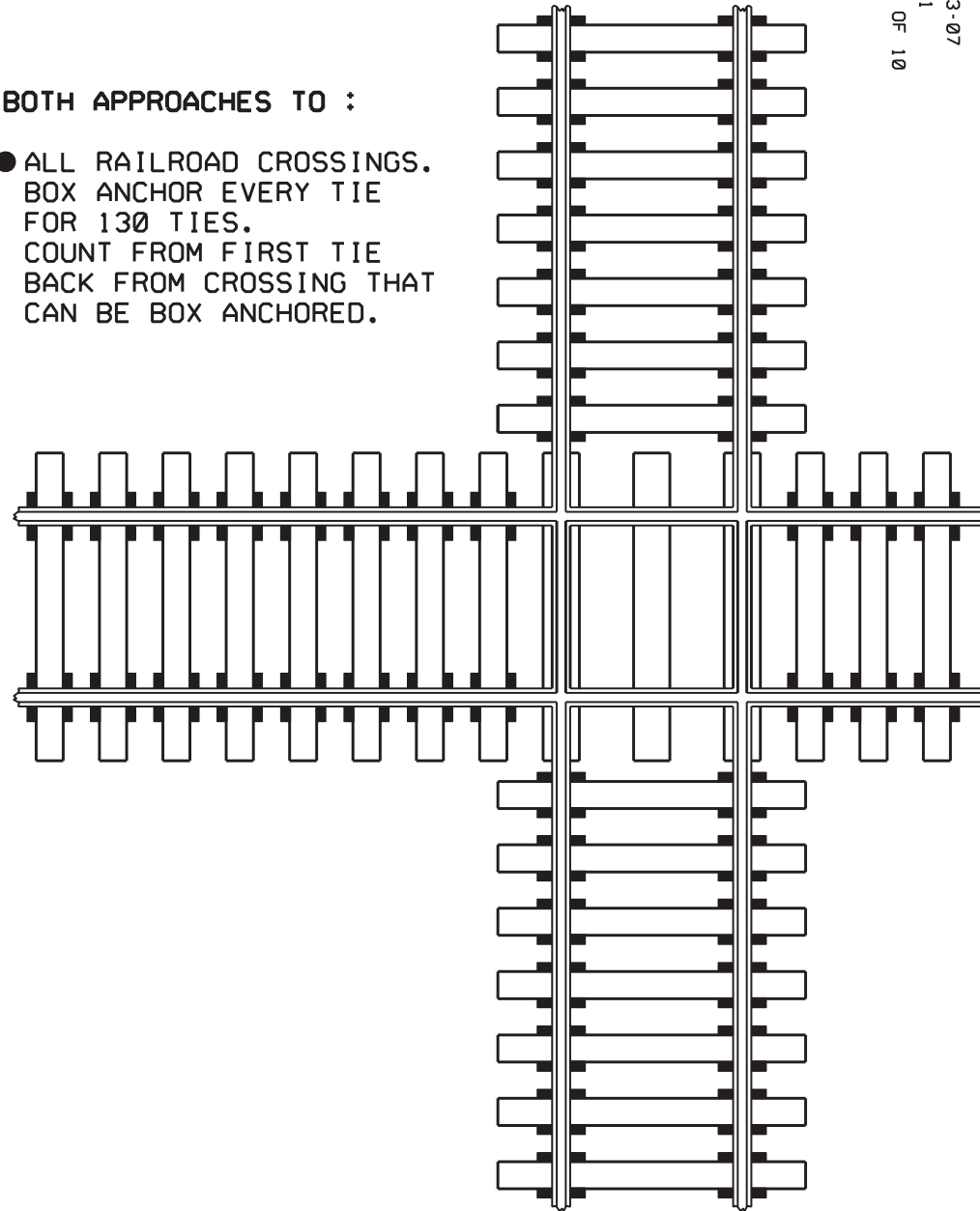

**WELDED RAIL ANCHOR PATTERN ADDITIONS**

**BOTH APPROACHES TO :**

- ALL OPEN DECK BRIDGES.  
BOX ANCHOR EVERY TIE FOR 130 TIES.

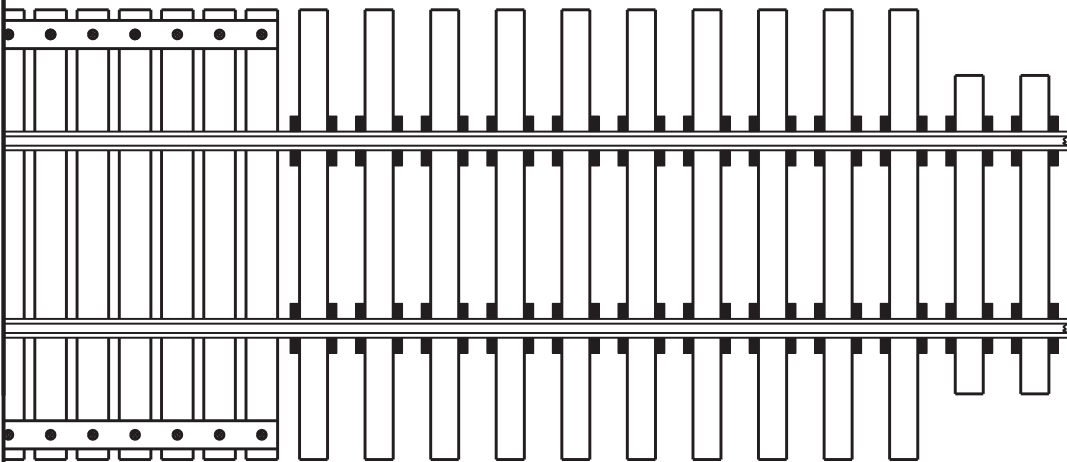

COUNT FROM BACKWALL OF BRIDGE.

**BOTH APPROACHES TO :**

- ROAD CROSSINGS 50 FOOT OR GREATER.  
BOX ANCHOR EVERY TIE FOR 130 TIES.
- ROAD CROSSINGS UNDER 50 FOOT.  
USE NORMAL ANCHOR PATTERN.

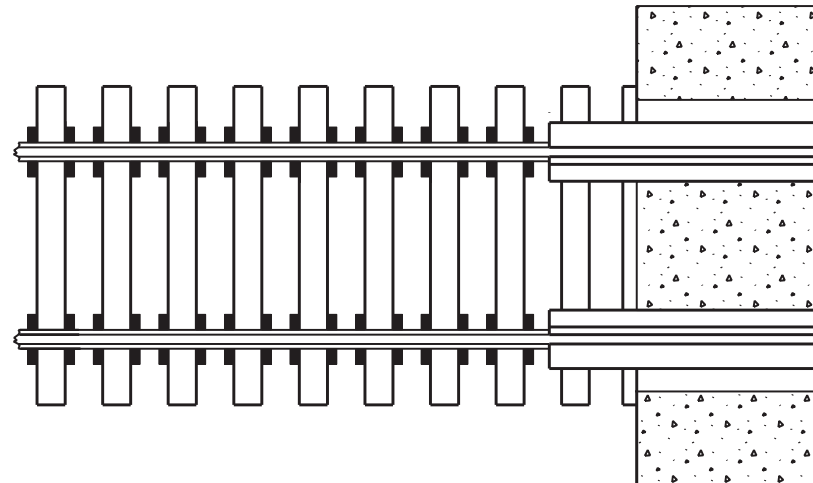

COUNT FROM FIRST TIE BACK  
FROM END OF CROSSING OR FROM  
JOINTS FOR CROSSING WARNING  
IF NOT EPOXY GLUED JOINTS.

**WELDED RAIL ANCHOR PATTERN ADDITIONS**

OPEN DECK BRIDGES WITH A TOTAL LENGTH OF 100 FEET OR LESS :

- RAIL ANCHORS WILL BE APPLIED ON ALL TIES FASTENED TO THE BRIDGE SPAN.

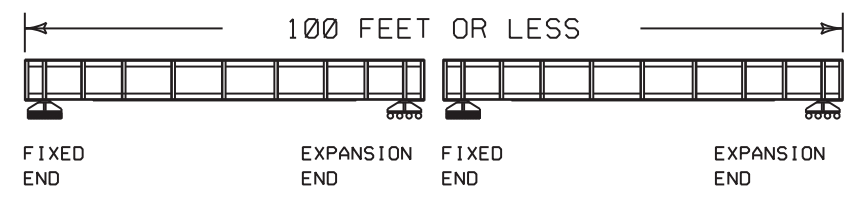

OPEN DECK BRIDGES WITH TOTAL LENGTH BETWEEN 100 FEET AND 500 FEET :

RAIL ANCHORS WILL BE APPLIED WITHIN THE LENGTH DESIGNATED ON ALL TIES FASTENED TO THE BRIDGE SPAN.

- RAIL ANCHORS WILL BE APPLIED THROUGHOUT ALL SPANS LESS THAN 100 FEET.
- RAIL ANCHORS WILL BE APPLIED FOR THE FIRST 100 FEET MEASURED FROM THE FIXED END FOR INDIVIDUAL SPANS WITH LENGTH GREATER THAN 100 FEET.

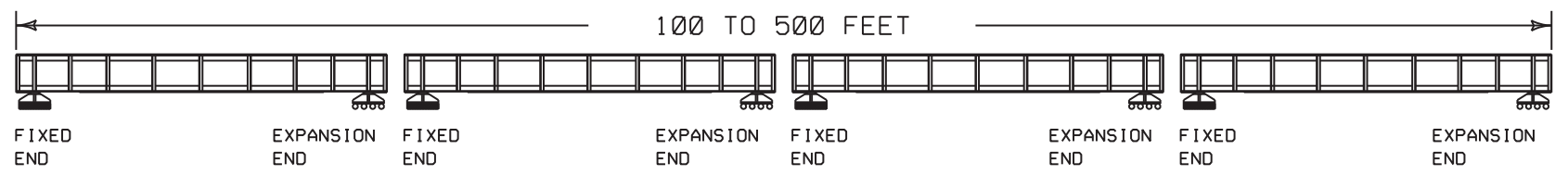

## WELDED RAIL ANCHORING ON OPEN DECK BRIDGES

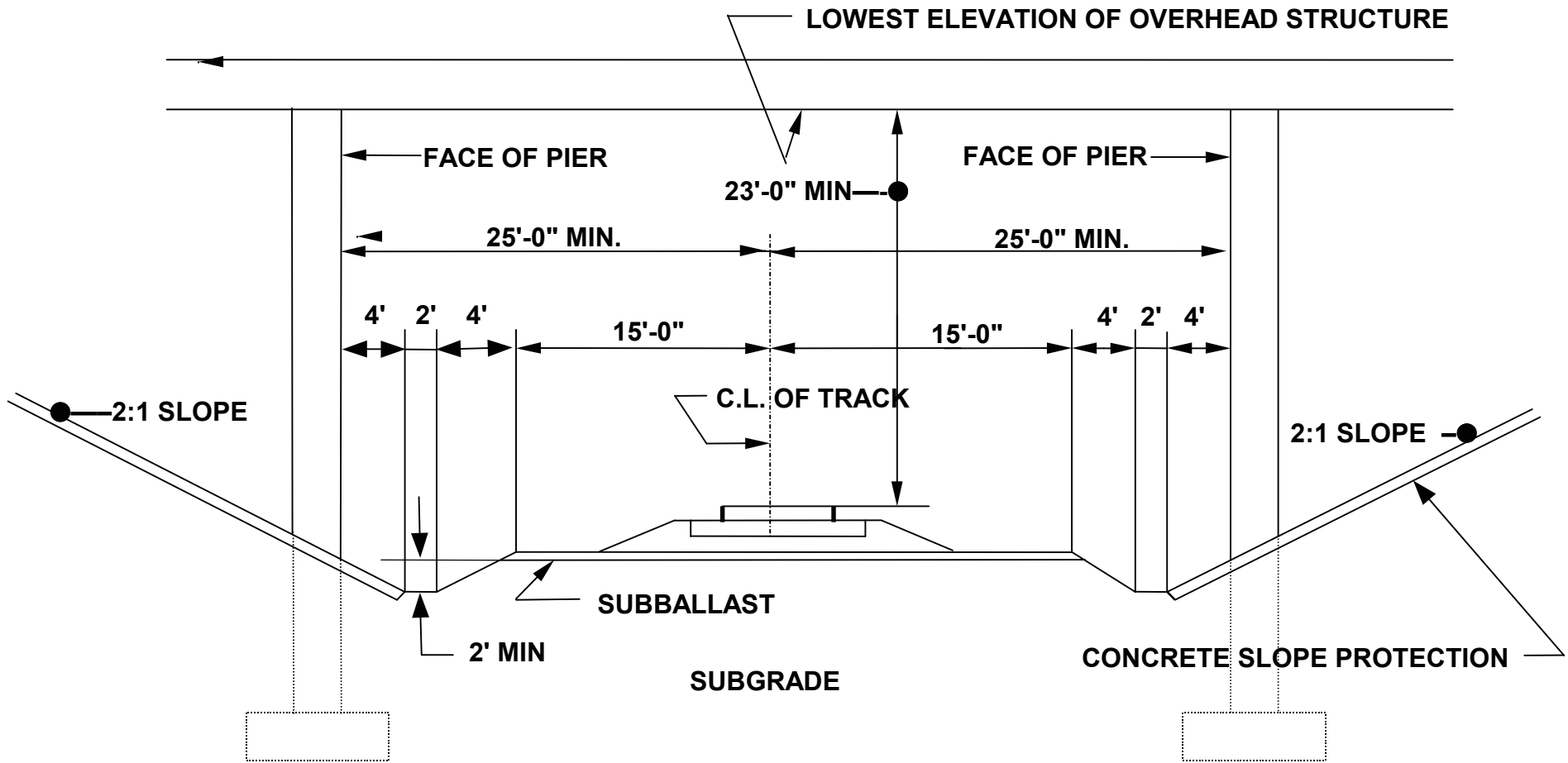

**CLEARANCES REQUIRED FOR OVERHEAD STRUCTURES**  
**TYPICAL ROADBED SECTION WITH STANDARD DITCHES**

**NOTE:** FOR MULTIPLE TRACKS, STANDARD TRACK CENTERS IS 15'-0"

**CSX TRANSPORTATION**  
 ENGINEERING DEPARTMENT

**STANDARD CLEARANCES FOR OVERHEAD STRUCTURES**



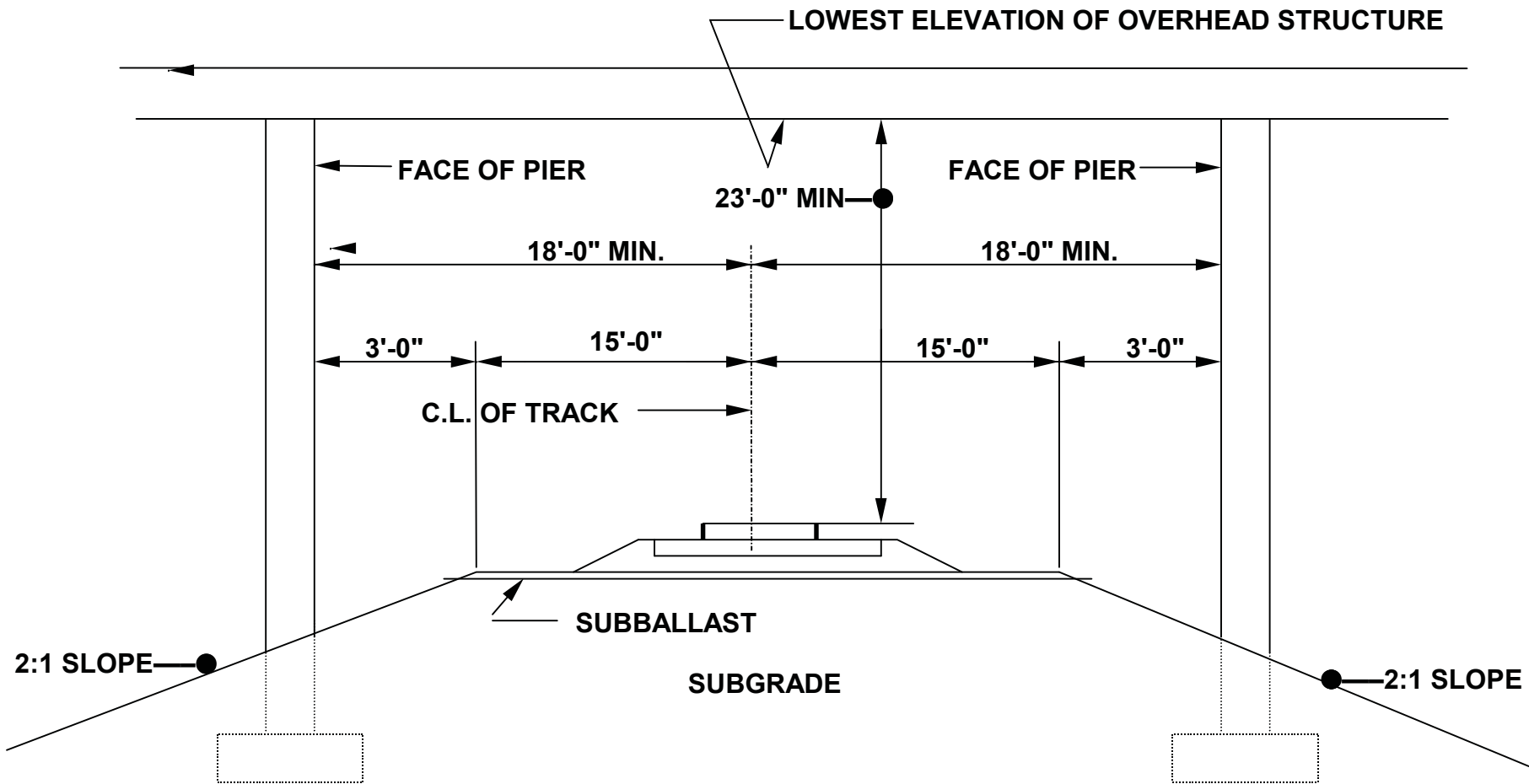

**CLEARANCES REQUIRED FOR OVERHEAD STRUCTURES**  
**TYPICAL SECTION FOR ROADBED IN FILL**  
 (WHERE NO DEFINED DITCHES ARE NEEDED)

**NOTE:** FOR MULTIPLE TRACKS, STANDARD TRACK CENTERS IS 15'-0"

**CSX TRANSPORTATION**  
ENGINEERING DEPARTMENT

**STANDARD CLEARANCES FOR OVERHEAD STRUCTURES**

# Adjacent Construction Project Manual

Office of Joint Development & Adjacent Construction



Washington Metropolitan Area Transit Authority  
600 Fifth Street, NW  
Washington, DC 20001

September 21, 2015 (Revision 5a)

This page intentionally blank.

## Preface

The Washington Metropolitan Area Transit Authority's (WMATA) Adjacent Construction Project Manual is prepared in the interest of and for the guidance of those who may contemplate construction activities that are adjacent to, beneath, on, or over existing WMATA property, facilities, roadway and/or operating Rights of Way.

The Manual outlines the general procedures and process requirements that must be followed when working in close proximity to any WMATA facility. It also covers WMATA design requirements, design review procedures, submittals, monitoring requirements, safety & security, operational requirements, real estate & insurance requirements and as-built documentation requirements.

The criteria provided herein are general and provide an overview of the design requirements. WMATA review and approvals are required prior to construction of the project. Refer to the Project Flow Chart and the Typical WMATA Design and Coordination Checklist in [Appendix 1](#).

It is WMATA's policy that projects be reviewed to insure that no adverse impacts will be caused to WMATA operations, systems and facilities and to assure the safe operation of the WMATA system.

The WMATA Office of Joint Development and Adjacent Construction (JDAC) within the Office of **Track Structures & Facilities (TSFA)** in the Department of **Chief Engineer Infrastructure Services (CENI)** has the lead responsibility to review, approve and oversee implementation for compliance with WMATA requirements for all construction adjacent to and/or impacting WMATA interests. This latest update has been issued by JDAC.

This update, Revision 5a (September 21, 2015) includes updated coordination and design requirements for joint development and adjacent construction projects.

This page intentionally blank.

## Preface

## Table of Contents

## Contact Information

<b>Section 1 -</b>	<b>General Procedures / Review Process .....</b>	<b>1</b>
1.1	Overview .....	1-1
1.2	Costs .....	1-2
1.3	Requests for WMATA Asbuilt Drawings .....	1-3
1.4	Submittals.....	1-3
1.5	Review Procedures .....	1-7
1.6	Access to WMATA Roadway and Facilities .....	1-7
1.7	Field Monitoring .....	1-9
1.8	Regular Bridge Inspection and Painting .....	1-9
1.10	Project closeout .....	10
1.11	Miscellaneous.....	1-10
<b>Section 2 -</b>	<b>NOT USED.....</b>	<b>2</b>
<b>Section 3 -</b>	<b>Design Requirements and Considerations .....</b>	<b>3</b>
3.1	Geotechnical Criteria, Structural Loadings and Zone of Influence .....	3-1
3.2	Earth Pressure Criteria .....	3-2
3.3	Support of Excavation - Design Criteria and Underpinning Provisions .....	3-2
3.4	Support of Excavation - General Requirements and Provisions .....	3-3
3.5	Design Pressures.....	3-4
3.6	Structural Excavation Support Elements.....	3-5
3.7	Support Systems with Tiebacks .....	3-10
3.8	Shop Drawings/Project Drawings .....	3-11
3.9	Limitations on Construction .....	3-12
3.10	Installation Criteria.....	3-14
3.11	Underpinning – General.....	3-14
3.12	Jacked Piles.....	3-15
3.13	Bracket Piles.....	3-16

3.14	Construction Adjacent to WMATA Tunnels .....	3-16
3.15	General - Construction adjacent to WMATA At-Grade Roadway and/or Facilities .....	3-18
3.16	Tunneling / Boring under WMATA Roadway .....	3-19
3.17	Excavation Adjacent to WMATA Roadway / Right-of-Way and At-Grade Facilities .....	3-19
3.18	Construction Adjacent to WMATA Aerial Roadway/Structures .....	3-19
3.19	Structures Built Directly Above or Adjacent to WMATA Roadway and Facilities .....	3-20
3.20	Blasting / Demolition Criteria .....	3-20
3.21	Certification and Documentation .....	3-21
3.22	Blasting Operations / Administrative Procedures / Prior Blasting 3-Notifications .....	3-21
3.23	Civil Criteria .....	3-22
3.24	Mechanical Criteria .....	3-22
3.25	Electrical and Communication Criteria .....	3-23
3.26	Redesign of WMATA Facilities .....	3-24
3.27	Energized Roadway / WMATA Right-of-Way Fencing .....	3-24
3.28	Grounding and Bonding - WMATA Structures .....	3-25
3.29	Lighting Standards - Impacting WMATA Structures/Property .....	3-25
3.30	Corrosion Protection .....	3-26
3.31	Certification of Design, Installation, and Monitoring .....	3-26
3.32	WMATA Vent Shaft Protection .....	3-26
3.33	WMATA Escalator Overhead Protection .....	3-27
 <b>Section 4 - Monitoring, Instrumentation and Contingency Plans .....</b>		<b>4</b>
4.1	General .....	4-1
4.2	Monitoring Stages .....	4-1
4.3	Monitoring Plan .....	4-2
4.4	Instrumentation .....	4-3
4.5	Guidelines - Monitoring & Instrumentation Minimum Requirements .....	4-4
4.6	WMATA Administrative Requirements .....	4-6
4.7	Minimum Monitoring Requirements .....	4-7
4.8	Monitoring Threshold or Limiting Values .....	4-10
4.9	Contingency Plan .....	4-12
4.10	ODC Monitoring Responsibilities .....	4-13

<b>Section 5 -</b>	<b>Safety, Operational Requirements and Compliance .....</b>	<b>5</b>
5.1	General.....	5-1
5.2	Safety, Construction, and WMATA Operational Considerations .....	5-1
5.3	Operational Requirements .....	5-3
5.4	Overhead Protection .....	5-3
5.5	Overhead Protection - Operating Roadway .....	5-5
5.6	Other WMATA Facilities.....	5-7
5.7	Modifications & Direct Connection to a WMATA Station / Facility .....	5-7
5.8	Americans with Disabilities Act / WMATA Compliance Requirements ...	5-9
5.9	Demolition.....	5-10
5.10	Safety & Security Certification Program Plan.....	5-10
<b>Section 6 -</b>	<b>Real Estate and Insurance Requirements .....</b>	<b>6</b>
6.1	Real Estate General Requirements.....	6-1
6.2	Procedures and Application Process.....	6-3
6.3	Real Estate Responsibility .....	6-4
6.4	Indemnification and General Insurance Requirements and Procedures .....	6-5
6.5	Insurance Responsibility .....	6-5
<b>Section 7 -</b>	<b>As-Built Documentation and Close Out .....</b>	<b>7</b>
7.1	As Built Documentation General Requirements .....	7-1
7.2	As-Built Drawings .....	7-1
7.3	As-built Drawing Submission Requirements.....	7-2
7.4	Closeout of Project .....	7-3



This page intentionally blank.

## **Appendices**

[Appendix 1 - General Procedures/Review Process](#)

[Appendix 2 - Not Used](#)

[Appendix 3 - Design Requirements and Considerations](#)

[Appendix 4 - Monitoring, Instrumentation and Considerations](#)

[Appendix 5 - Safety Requirements & Compliance](#)

[Appendix 6 - Real Estate, Insurance & Design Criteria Section 9 – Right-of-Way](#)

[Appendix 7 - As-Built Documentation & Closeout](#)

[Abbreviations](#)

[Glossary](#)

This page intentionally blank.

## Contact Information

Link to JDAC Adjacent Construction Manual:

[http://www.wmata.com/business/joint\\_development\\_opportunities/adjacent\\_construction\\_information.cfm](http://www.wmata.com/business/joint_development_opportunities/adjacent_construction_information.cfm)

WMATA Joint Development Adjacent Construction:

Email: **JDAC@WMATA.com**

WMATA Web Address: <http://www.wmata.com/>

### For Emergency Use Only:

WMATA Department of System Safety & Environmental Management (SAFE):  
(202) 962-1057 or 1-888-637-1329 (24 hr. pager)

WMATA Transit Police: (202) 962-2121

WMATA MOCC: (202) 962-1530

This page intentionally blank.

## Introduction and General Procedures

This Manual describes WMATA offices (WMATA) review, approval and operational support process for projects proposed adjacent to, on, over, or under WMATA property and/or facilities which may impact an existing WMATA facility, the Roadway, bus routes and/or bus stops.

### Section 1 - General Procedures / Review Process

#### 1.1 Overview

WMATA will review plans for projects adjacent to, on, over, or under WMATA property and joint development projects to ensure that: (1) WMATA facilities and operations are not damaged or affected by the proposed project; (2) WMATA operations are not impacted during and after the proposed project construction; (3) WMATA station capacity is not affected by the ridership generated by these projects; and (4) facilities being built for WMATA to own, operate and maintain comply with WMATA Design Criteria, Administrative and Technical Specifications, Standard Drawings, Design Drawings and this Manual.

Each project will be assigned a unique Project Control Number (PCN). This number must be referenced in all communications with WMATA.

Construction plans will be reviewed to determine whether the proposed construction falls within WMATA's Zone of Influence (ZOI), as defined in Section 3 of this Manual, and whether the project will have an impact on WMATA's facilities or revenue operations.

It is the general policy of WMATA to review the design for the construction of projects adjacent to, on, over, or under WMATA property on a case-by-case basis.

The Owner/Developer/Contractor (ODC) will provide a study/report showing that any additional ridership generated by a project will not cause current Metro station facility capabilities to be exceeded. The study must include mitigation measures if the proposed project adversely impact WMATA. This may include, but not limited to, required expansion of facilities such as the station entrances, elevators, escalators, fare gates, fare vending machines and station mezzanines etc. The costs of any new facilities or revisions to existing facilities will be borne by the ODC. These requirements will be coordinated with all involved parties.

A flow chart is included in [Appendix 1](#) showing the necessary steps and time requirements for adjacent construction project start-up. These are minimum time frames which could be extended depending on the complexity and scope of the project. ODCs are to consider this when developing the project schedule.

- A.** The ODC is to submit design and construction documents to the WMATA Office of Joint Development and Adjacent Construction (JDAC).
  - 1.** The ODC shall provide sufficient drawings and details showing project plan and cross sections to evaluate whether the proposed construction will or

will not be in WMATA's ZOI. Construction plans will not be approved until this information is confirmed.

2. To insure proper coordination of the project, one (1) person shall be designated by the ODC to WMATA as the authorized point of contact to represent the project (including tiered subcontractors and designers). All contact from WMATA to the project will be through the designated representative.

**B.** The ODC will be advised of WMATA review findings as follows:

1. **No impact.** Letter confirming no impact.
2. **Impact.** Letter Agreement, assigned Project Control Number (PCN), and assignment of WMATA JDAC Project Manager (PM), Construction Engineer (CE) and Construction Inspection Facilitator (CIF).

**C.** The CE is the point of contact for project reviews and approvals, real estate entry permit, interface and coordination with operations and maintenance offices. The CIF coordinates field activities and oversight. The PM/CE/CIF coordinate with WMATA staff for this work as necessary.

**D.** All project communications must include the PM/CE/CIF in addition to the PCN.

## 1.2 Costs

JDAC determines which projects will have impact to WMATA. The services of WMATA's staff are invoiced to the project to provide necessary oversight of the work and ensures that WMATA's interests are protected. Costs, as determined by the Authority, are based on the estimated Level of Support required by the project, and construction schedule duration of the project. Once a project has been identified as having impact to WMATA, the ODC will be advised as to the estimated costs for supporting the project. **Payment is required prior to WMATA completing any review or the ODC accessing WMATA property.**

**A.** WMATA will require a lump sum advance payment of the estimated cost to coordinate and process project submittals, access requests, reviews and other support required of the project by this Manual and the Authority. This includes, but is not limited to, the following:

1. Reviews
2. Operational Support (e.g., escorts, flagging, support services)
3. Operational adjustments (e.g., bus bridging, single tracking, bus detours)
4. Coordinating and monitoring of construction

- 5. Administrative costs
  - 6. Third-party consultant support (e.g., reviews, inspections, testing)
  - 7. Lost revenue (e.g., lost parking revenue)
  - 8. Modification, repair and/or purchase and installation of any facilities as a result of the Project
- B.** Costs for operational support, and support services for adjacent construction and joint development projects where access is required into the operating Metrorail system, or where other WMATA facilities are impacted, will be invoiced separately project by project.
  - C.** Costs for Revenue Service Adjustments and/or modified service such as, shutdowns, single tracking or bus route modifications will be additional and determined on the approval of the Site Specific Work Plan (SSWP) requirements.

Costs for easement, right of entry, or acquisition of WMATA property interests will be invoiced separately from WMATA's Office of Real Estate and Station Planning (LAND).

- D.** All correspondence, payments, etc. shall reference the unique PCN.

### **1.3 Requests for WMATA Asbuilt Drawings**

- A.** To obtain electronic files of WMATA's as-built records, the ODC must submit a completed Document Request Form (DRF) [Appendix 1](#). WMATA conducts background checks of the ODC representative. Upon WMATA approval of the request, JDAC will provide PDF's of the requested records to the ODC, if available.
- B.** ODC shall field verify, document and engineer their proposed project relative to existing WMATA facilities and utilities in accordance with the applicable sections of this Manual.

### **1.4 Submittals**

Submittals are to be submitted to the CE electronically through WMATA's electronic data management system (EDMS) – Procore. The submittals should include a cover sheet, such as, a transmittal. Additionally, ODC shall provide multiple hard copies (quantity to be determined for each project, but not less than (3) of each submission for WMATA review.

- A.** Project design: General plans of the project showing relative proximity of the work specific to WMATA interests. Where WMATA interests are impacted, specific detailed plans of the work are to be provided.
  - 1. Designs for the protection, support and underpinning of existing WMATA structures will be coordinated internally within WMATA's Offices by JDAC.



**WMATA underground structures shall be fully re-evaluated for the effects caused by the adjacent construction, using working stress methods.** The stresses and deflections induced in the existing WMATA structures shall be provided. The short-term and long-term effects of the new loading due to the adjacent construction on the WMATA structures shall be provided. The soil parameters and other pertinent geotechnical criteria contained herein shall be used to analyze the existing WMATA structures. WMATA structures shall be analyzed for differential pressure loadings caused by dewatering the adjacent construction site.

2. The ODC shall maintain, protect, and be responsible for the safety, stability, and integrity of all adjacent WMATA structures which may be affected by the work.
3. The ODC shall submit dimensioned clearances, both horizontal and vertical, between the adjacent construction project and WMATA structures, tracks, roadways, parking areas, and utilities. WMATA's easements / right-of-way must be clearly identified on all site plans. Project encroachment(s) shall be specifically identified.
4. Details of the proposed modifications to WMATA's facilities, roadways, parking areas, and busways shall be provided. Include sections and details showing the interface of existing and proposed facilities.
5. Provide cross sections with the existing and proposed contours and limits of grading work shown in relation to the property lines and the impact on or to WMATA facilities. Where grading changes are required on WMATA property, provide the dimensions and square footage of the area required for construction easements.
6. Hydrologic and hydraulic calculations showing the impacts on the WMATA drainage system are required if storm drainage from the proposed development is to be discharged into the existing WMATA drainage system. Storm discharge must be reviewed and approved by WMATA in advance and will require a real estate permit/agreement. Appropriate sedimentation and erosion control measures should be included.

NOTE: No ODC may use WMATA's drainage system for their use either temporary or permanent.

7. Where modifications to WMATA utilities are required by adjacent construction, submit for review cross sections, plan and profiles, specifications and design calculations concerning the utility modifications. Details for maintaining utility services to WMATA facilities shall be shown when WMATA utilities are impacted.
8. Where construction will impact a WMATA station entrance, parking facilities, bus facilities and the public's access to the station, the submittal shall include plans for temporary pedestrian and vehicular traffic circulation

for the area around the station entrance. Where construction is adjacent to or above a WMATA station entrance, protection will be required over the pedestrian areas, escalators and elevators. Provide signed and sealed construction plans, shop drawings, or working drawings showing the phasing of adjacent construction as well as the construction details for overhead protection, pedestrian barricades, and sidewalk protection. Requests for relocation of bus stops and bus shelters shall be clearly shown on the plans. Barricades and signage necessary to direct the public through the construction zone shall be required. Lighting shall be required as part of all overhead protection structures.

9. Provide for review and approval, design and construction documents for projects requiring an expansion of WMATA station facilities. This may include additional or expanded entrances, additional fare gates, fare collection equipment, additional or expanded mezzanines and vertical circulation elements, etc.
10. Provide construction protection details to preclude impacts on WMATA landscaping, street furniture, pylons, bus shelters, and light fixtures.
11. When a gas line is proposed to be installed under a WMATA track, WMATA tunnel, WMATA power feeds or other facility, provide the safety measures to be taken, sleeve or safety jacket, etc., so that WMATA track, tunnel or other facilities would be protected in case of gas leaks and/or explosion.
12. Any and all power requirements are the responsibility of the ODC. Temporary and/or permanent use of WMATA power systems is prohibited.

**B.** The following is a partial list of potential submittals required:

1. Civil Drawings - site plan showing all existing conditions, including building and basement level(s), parcel limit, distances from WMATA facilities, structures, and utilities. Show demolition area if any. NOTE: No bioretention pond or open water feature is allowed over or near WMATA facilities.
2. Architectural Drawings - showing new project layout, including plans, elevations and sections.
3. Structural Drawings - showing foundation plans, elevations, sections, and loads.
4. Geotechnical report.
5. Signed and sealed Calculations.

- 6.** Support of Excavation, Structural monitoring and contingency plans. ODC shall allow sufficient time (recommend initial submittal not less than six (6) months in advance of scheduled construction) for review and approval of plans. NOTE: ODC shall refer to Section 3 for support of excavation details.
- 7.** A construction sequence and heavy equipment plan shall be submitted indicating the position and loading of major construction equipment, particularly equipment within the WMATA ZOI, and/or crane positions including crane swing radius, which operate with potential to foul WMATA Roadway, impact to any WMATA facility, pedestrian and vehicular access areas.
- 8.** Permanent easement and/or property disposition. Submission is required of a sealed survey plat illustrating the proposed impact to WMATA's property interests, certified legal survey descriptions (Metes & Bounds), and a certified boundary survey tying the project survey into WMATA's coordinate system. This shall be developed and submitted with initial Support of Excavation plans. It is recommended that all impacts to WMATA property interests be addressed in this submittal. Allow a minimum of six (6) months to conclude the review and approval process for issues involving support of excavation and property impact issues.
- 9.** Preconstruction survey data.
- 10.** Material and catalog cut information, Material Safety Data Sheets (MSDS).
- 11.** Insurance policies and certificates of insurance which conform to standard WMATA insurance requirements and coverages including railroad protective liability insurance requirements (as applicable).
- 12.** Updated construction schedule bar chart which is specific to impact on WMATA facilities, Roadway and/or coordination efforts. The project bar schedule should clearly illustrate work activity impact to WMATA facilities and adjacent construction support / coordination requirements from WMATA personnel.
- 13.** Phasing plans and Maintenance of Traffic (MOT) plans which should include pedestrian and vehicular impacts.
- 14.** Drainage area maps and calculations, as necessary.
- 15.** Electrical drawings, photometric studies and lighting plans, as applicable
- 16.** Simulation studies for traction power, as applicable
- 17.** Blasting, monitoring and contingency plans, as applicable

18. Safety and protection plans, as applicable
19. Other materials as requested by WMATA.

## 1.5 Review Procedures

- A. Design work will be reviewed based upon the assumption that the design will meet all applicable codes adopted in the jurisdiction as well as the current WMATA Design Criteria, Design Drawings, Standard Drawings, Administrative and Technical Specifications as well as the ACPM.
- B. Permits, where required by the local jurisdiction, utility agencies and railroads shall be the responsibility of the ODC. Copies of these permits must be provided to the CE.
- C. WMATA review periods - The ODC should allow **no less than** a period of thirty (30) business days for each WMATA review of submittals. Reviews are conducted on a 'first-come-first-served' basis. Incomplete submissions will delay the review process and may be returned. ODC is responsible to ensure that submissions comply with WMATA's requirements.
- D. Allow thirty (30) business days for each successive review.
- E. Use of JDAC's Comment-Response Matrix will be required for all review comments and responses on submittals.
- F. WMATA's acceptance of the ODC project documents will remain in effect for a 120 day period (4 calendar months) or as previously agreed to by WMATA. If the project goes dormant or does not advance to the next phase the ODC will be required to provide WMATA with written certification that the previously accepted submittals are still valid.
- G. Construction documents approved by WMATA and changed by the ODC must be resubmitted for approval.

## 1.6 Access to WMATA Roadway and Facilities

Depending on the nature and extent of impact a project may have on the WMATA system, access to the Roadway/Wayside (tracks) and non-Wayside facilities may be necessary. All work within WMATA's Roadway must be performed during non-revenue hours or as approved in advance. WMATA cannot guarantee that the ODC will be able to work within the scheduled non-revenue hours. This access will assist in completing pre and post construction inspections, installation and removal of monitoring equipment, and surveying locations of existing installations.

- A. WMATA Contractor ID Badge is required for all personnel that will be accessing any WMATA property and/or facilities. The following forms must be completed and submitted to obtain the required ID badge.

1. [Certification for Issuance of Metro SmarTrip® Contractor Badge](#)
    - a. Complete the upper section (Contractor Employee Name, SS number).
    - b. Provide the form(s) to the assigned CE or CIF who will complete Section 1.
    - c. All ODC personnel entering WMATA's Roadway and facilities are required to have cleared a background check before a badge will be issued.
  2. [Acknowledgement and Authorization for Background Screening](#) is to be completed by the requestor.
  3. Both forms must be hand delivered to WMATA's ID Office.
  4. The ID Badges are good for a maximum of one (1) year.
- B.** Completion of the WMATA's Contractor Roadway Worker Protection Training course is required for all personnel designated for wayside work and any electrical facility.
1. Training is provided by WMATA Department of System Safety and Risk Management (SAFE) at no cost to the ODC. Scheduling should be coordinated through the assigned CE or CIF.
  2. The ODC will be charged if the employee fails to attend the scheduled training class.
- C.** A completed Site Specific Work Plan (SSWP)
- D.** The ODC must submit a JDAC Support Request (JSR) Form for any work activities on WMATA property that will require operational support.
1. A JSR is required for each activity (event).
  2. An SSWP must be submitted for all work activities on WMATA property regardless if the activity requires operational support.
- E.** For any operational support, a JDAC Daily Support Tracking Form must be completed. See [Appendix 5](#). The completed form must be signed and emailed to the CIF/CE by the next business day.
- F.** An executed real estate permit and insurances are required to work on WMATA property or perform work which may impact WMATA interests. Reference Section 6 and Appendices for WMATA real estate permit and insurance requirements.
- G.** Upon receipt of executed permit the ODC shall contact JDAC's Supervisor of Field Projects a minimum of ten (10) days in advance of scheduling the required pre-

construction site meeting. A checklist of the requirements that will be discussed at the onsite pre-construction meeting is included in [Appendix 1](#).

## **1.7 Field Monitoring**

- A.** Monitoring of the temporary support of excavation structures for adjacent construction shall be required in all cases for excavations within WMATA's ZOI and as deemed required by WMATA. The extent of monitoring will vary from project to project depending on each project's specific impacts.
- B.** The ODC shall develop a plan to monitor affected WMATA facilities, structures and/or tunnels.
- C.** Monitoring of the inside of WMATA tunnels and structures will be required when the adjacent excavation will change the loads on, or could cause movement of the WMATA structure or tunnel. For this purpose, a pre-construction survey of the WMATA structures, will be required and will serve as the monitoring baseline reading. Escorts will be required for the survey parties entering the WMATA operating system in accordance with WMATA Operating Regulations.
- D.** The ODC shall monitor conformance with the approved staging plans effecting WMATA operations.

## **1.8 Regular Bridge Inspection and Painting**

WMATA will support regular bridge inspections and painting by local jurisdictions and states (ODC's) within WMATA's Roadway. This section does not exempt the ODC from any applicable section of this Manual.

- A.** Most inspections and/or painting activities will occur from the ground at track level using ladders or from overhead via the bridge deck by use of a snoopers truck or similar equipment. Since, in both cases, the inspection will be within the WMATA Roadway, Section 1.6, Access to WMATA Roadway and Facilities, applies to the ODC.
- B.** WMATA will review the safety plan as provided in the SSWP. The ODC must submit the work description, plans, materials, MSDS, protection and schedule. In addition to the type, size and location of the bridge, the ODC must depict the inspection and painting equipment for WMATA review. Any structure that will be installed to perform the work must be submitted for review. Note that there is no WMATA equipment available for ODC use.
- C.** WMATA will estimate costs in accordance with Section 1.2 of this manual. All work will be performed during non-revenue hours. The ODC will provide a copy of the bridge inspection report at the completion of the work for WMATA's record.

## **1.9 Potential Impacts to Bus Routes and Stops**

For any project that will affect a Metrobus stop or route, permanently or temporarily, the ODC will initiate contact with JDAC and the Office of Bus Planning (BPLN) [metrobusplanning@wmata.com](mailto:metrobusplanning@wmata.com). Provide a description and plans of any affected bus stops and/or routes in the project area.

### **1.10 Project closeout**

The ODC must advise WMATA in writing when project construction impacting WMATA is complete and ensure all WMATA punch list items have been completed. In accordance with WMATA's real estate permits, as-built documentation is also a project requirement where permanent modifications are being made on, above, below, or to WMATA property. WMATA requires as-built documentation be submitted in accordance with WMATA format requirements in AutoCAD and PDF formats on a CD. See Section 7 Asbuilt Documentation and Closeout.

In addition to the above, all financial obligations must be met.

### **1.11 Miscellaneous**

- A.** If uncertainty exists on the possible impacts a project may have on the WMATA facilities and before making a formal application for a review of a construction project adjacent to the Metro System, the ODC must contact JDAC for assessment of the project impact.
- B.** Contract drawings and specifications shall contain a general notes section outlining the scope of work and manner of prosecution of the proposed transit improvement and impacts thereto.
- C.** WMATA reserves the right to place JDAC CIF or other WMATA personnel on the site to observe the effects of the project's construction on WMATA's facilities.

**Section 2 - NOT USED**



This page intentionally blank.

### Section 3 - Design Requirements and Considerations

General Note: Specific designs performed by the Authority, or its consultants may not necessarily be in conformance with the current WMATA Design Criteria or this Manual's appendices. It is considered the Owner/Developer/Contractor (ODC) responsibility to obtain the original design computations, where available, from WMATA to completely understand the original design intent in order to accurately assess the impact of their proposed construction on WMATA structures, facilities and utilities.

#### 3.1 Geotechnical Criteria, Structural Loadings and Zone of Influence

**A.** Geotechnical/Structural evaluation of the adjacent construction shall be based on WMATA's Standard Design Specifications and the WMATA Design Criteria. WMATA facilities are considered to be affected by the adjacent construction when the proposed excavation and construction is in the WMATA Zone of Influence (ZOI). Existing WMATA deep foundations, retaining walls, and underground utility lines are considered to be a part of WMATA facilities.

**B.** Zone of Influence:

The four following criteria shall be considered in determining WMATA ZOI. If any one of the four criteria applies, the proposed adjacent construction or excavation is considered to be within WMATA ZOI.

1. If the proposed excavation is within 25 feet (horizontal / plan dimension) of a WMATA facility. If the proposed augering of soldier piles and bearing piles are within 25 feet of WMATA facilities.
2. An envelope starting at a point two feet below the lowest point of the underground structure or excavation continuing upward at a forty five (45) degree angle from the horizontal at the vertical projection of the outside limits of the WMATA structure.
3. An envelope starting at a point two feet below the lowest point of WMATA structure continuing upwards at forty five (45) degree angle from the horizontal line, up to the horizontal projection of the outside limits of the adjacent structure or excavation, projected at grade level. The (45) degree influence line defining WMATA ZOI envelope should extend until it intersects existing ground line as depicted on plate A-2A ([Appendix 3](#)).
4. If the proposed rock blasting operation is within 100 feet of WMATA facilities.

**C.** If the proposed construction will be located within the WMATA ZOI the WMATA Design Criteria and Standard Specifications shall be utilized for design and construction of the portion of the proposed facility within the WMATA ZOI.

- D. When the structure adjacent to an existing WMATA structure is required to support or provide resistance to re-establish the 'Long Term' loading on WMATA's structure(s), adjacent structure(s) should be designed for loads accordingly. In the case of uncertainty, the developer must contact WMATA for clarification before design begins.

### 3.2 Earth Pressure Criteria

- A. The at-rest coefficient of earth pressure ( $K_o$ ) is expressed as:  
$$K_o = 1 - \sin\Phi$$

- B. The active coefficient of earth pressure ( $K_a$ ) is expressed as:  
$$K_a = \tan^2(45 - \Phi/2)$$

- C. The passive coefficient of earth pressure ( $K_p$ ) is expressed as:  
$$K_p = \tan^2(45 + \Phi/2)$$

In these equations the effective friction angle ( $\Phi$ ) should be taken from Table 3-3 of this Manual's [Appendix 3](#), and cohesion,  $c$ , shall be considered to be zero.

[If a geotechnical report is prepared, and submitted to WMATA, based on sufficient job specific borings and other geotechnical investigation, other values of effective friction angle ( $\Phi$ ) may be used at the sole discretion of WMATA.]

- D. Plate A-4 in [Appendix 3](#), presents the vertical pressure distribution to be assumed for the loads from the adjacent construction. The effect of resulting lateral loads due to the adjacent construction shall be added along with the vertical pressures, on WMATA structures.
- E. Underpinning Protection Requirements - Plate Nos. A-3A and A-3B in [Appendix 3](#), depict the zone in which underpinning will be required as a result of construction adjacent to WMATA structures. The same principle shall be applied to determine the effects that proposed construction may have on other WMATA facilities.

### 3.3 Support of Excavation - Design Criteria and Underpinning Provisions

- A. Lateral design loadings to be used for adjacent construction projects are shown in [Appendix 3](#), Plate A-1A and Plate A-1B. Plate A-6A and A-6B show temporary construction loads that shall be added to the lateral earth pressures when developing the horizontal forces acting on the proposed support of excavation.
- B. The original basic design loadings used for the design of WMATA structures and tunnels are presented in [Appendix 3](#), Plate Nos. A-5A, A-5B, A-7A and A-7B. These diagrams are presented to indicate the earth pressure used in the original design of the WMATA facilities. Thus, if the changed earth pressures due to the proposed excavation and construction can be maintained within the limits of the original design pressures (for example the short term loading and the long term loading) at all times, the structural analysis of the existing WMATA facilities can be eliminated, with prior approval of WMATA.

If the tunnel or structure was originally designed by NATM Method, the ODC shall provide a structural adequacy check, based on procedure or computer program

acceptable to WMATA, on WMATA structures. This requirement may be waived at the Authority's discretion.

For tunnels and other structures in rock, the ODC shall provide a structural adequacy check, based on the loading provided in this Manual or based on procedure or computer program acceptable to WMATA, on WMATA structures. This requirement may be waived at the Authority's discretion.

**C.** For construction proposed within the ZOI the following analyses shall be included in the submission:

**1.** Establish diagrams illustrating the pressures used in the design, including the long term / existing pressures on the underground WMATA structures. Illustrate the variation in the existing pressures due to the various construction phases, including full excavation to subgrade (which may control) and when the structure is complete. A structural evaluation will not be required if the proposed pressures/loads on WMATA structures are within the limits of WMATA's initial structural design.

If the proposed pressures/loads on WMATA's structures fall outside initial design limitations (of WMATA structures), then a structural analysis will be required to verify that the anticipated earth pressures will not cause over stressing or cracking. The analysis must be submitted for WMATA review and approval. The Authority, may at its sole discretion, waive such an analysis based on the amount of variation in pressures / loads acting on WMATA structures.

**2.** The design for the excavation support system shall include consideration of a deep seated slope stability analysis of the soldier pile or sheeting wall.

**D.** As necessary, or if required by WMATA, an analysis shall be provided of the existing WMATA structure for the anticipated loads.

**E.** Provide the details of any proposed construction dewatering or groundwater drawdown planned during the adjacent construction. Settlement analysis of the existing WMATA facilities shall be performed if the foundations are founded in a subsurface strata of loose material with a thickness of more than 5 feet.

**F.** If laid back slopes are used at the top of excavation support system, and if they are steeper than one vertical to one and a half horizontal, a slope stability analysis shall be provided.

### **3.4 Support of Excavation - General Requirements and Provisions**

**A.** The design of the temporary structures shall be the responsibility of the ODC. This section presents minimum design and construction requirements to facilitate WMATA review of support of excavation submittals.

**B.** Temporary structures may be designed with laid back slopes as long as the soil loads are taken as equivalent to the full height of the excavation from the subgrade

under the working slab to the original street grade or surface elevation of the soil before excavation.

- C. If design criteria and/or methods given in any of the Reference Standards differ with a criteria and/or method explicitly stated in this Manual, then this Manual's criteria and/or method shall govern.
- D. The support systems acceptable to WMATA are steel soldier piles with timber lagging, steel sheet piles, slurry (diaphragm) walls, secant pile walls, tangent pile walls secured in place with bracing members such as walers, rakers, shores, struts and ground anchors. Also for small utility trenching, trench boxes are acceptable. Approval of any other methods of support of excavation will be at the sole discretion of WMATA.

### 3.5 Design Pressures

- A. Lateral Earth Pressure and Groundwater Pressure. The basic horizontal earth pressures shall be computed using the active earth pressure. The resultant or total active earth pressure shall be multiplied by a stiffness factor depending upon the required stiffness. The resulting load shall be redistributed on the cofferdam in a trapezoidal pressure diagram similar to that shown in Plate A-1A or A-1B of [Appendix 3](#). The stiffness factors shall be applied to both the cofferdam design and the bracing system. The stiffness factors shall be assigned as follows:
  - 1. Use stiffness factor = 1.25 for a soldier pile and lagging or a sheet pile support system.
  - 2. Use stiffness factor = 1.5 for a slurry wall, secant and tangent pile wall support system.

If the water table is above the subgrade, and if de-watering is not done, consider the effect of the lateral water pressure and modify the active earth pressure accordingly.

- B. Depending upon the type of soil, the ordinate of the resultant trapezoidal pressure diagram in pounds per square foot shall be at least equal to 25H (for a soil with  $\Phi=38$  degrees, and a stiffness factor of 1.25) and 29H (for a soil with  $\Phi=38$  degrees, and a stiffness factor of 1.50), where H = the height in feet of the excavation between the subgrade under the working slab and the surface of the ground. The bottom of a laid back slope at the top of the cofferdam shall not be used as the upper limit in determining the value of H. Any other excavation support systems (not accepted by WMATA in Section No. 3.4B), with the exception of soil nailing walls, shall be designed for at-rest earth pressure ( $K_0\gamma_s H$ ) and full water pressure.

Appropriate soil and rock properties listed in [Appendix 3](#), Table No. 3-3, shall be used in computing soil pressures and other analysis. Note that cohesion of soil shall not to be considered in the analysis (cohesion,  $c = 0$ ), for all types of soils.

- C. Ground water pressures shall be estimated based upon the existing water levels or on permissible drawdown levels, plus an allowance for seasonal variation. Where soldier beams with wood lagging are to be used, ground water may be assumed to be below the level of the interior excavation subgrade. When the shoring wall is intended to prevent all leakage of ground water the exterior water level shall be used and accounted for in the design.
- D. The passive earth pressure available to resist the forces placed upon the temporary support structure shall be computed using the conventional expressions for passive earth pressure. Friction forces on the cofferdam shall be ignored. A safety factor of 1.5 shall be used when computing the theoretical passive resistance. The passive earth pressure should be reduced with consideration of slopes and berms in front of the support system.
- E. Frictional forces shall be considered only on the embedded soldier pile length below the subgrade when balancing the vertical forces imparted to the support structure by rakers or tiebacks. Determine the allowable bearing capacity by applying a safety factor of 3.0 to the ultimate bearing capacity.
- F. The trapezoidal shaped pressure diagram as shown in Plate A-1A of [Appendix 3](#) is applicable only for a multi-level tieback, strut or raker support system. A triangular shaped pressure diagram, as illustrated in Plate A-1B of [Appendix 3](#), shall be used for the single level strut, raker, or tieback support system.
- G. Surcharge Pressure. The structural support system design shall consider the effects of all loads resulting from construction equipment, construction trailers, supported utilities, stockpiled materials, cranes, concrete trucks, and non-underpinned buildings adjacent to the excavation. Minimum surcharge pressure is shown in Plate A-1A, Plate A-1B and Plate A-6A of [Appendix 3](#), which is based on a vertical construction surcharge of 600 pounds per square foot acting adjacent to the excavation. For more severe construction loading a special analysis shall be conducted.
- H. Base Stability of Excavation. The stability of the base of the excavation must be evaluated for all excavation support systems. The evaluation shall consider piping due to seepage, unbalanced external forces, base stability of cohesive soils, etc. An acceptable method of evaluating the stability of the base of the excavation shall be in accordance with the procedures presented in the US Navy Design Manual 7.02, Foundations and Earth Structures.

### **3.6 Structural Excavation Support Elements**

- A. The excavation construction sequence and its effect on the struts, corner braces or diagonal struts, rakers, walers and soldier piles shall be examined for the various stages of partial excavation. The condition where the soldier pile is assumed to be continuous over the brace immediately above the excavated level may produce a condition of maximum loading in the support structure. The excavation support members shall be sized accordingly. For raker bracing system use reduced passive pressure acting on the soldier beams due to the soil sloping down from the edge of berms, for the partially excavated conditions.

When the support of excavation is closer than 10 feet (horizontal dimension) to the WMATA vent structures/ shafts, station locations or underground tunnel sections, WMATA may require the ODC to provide a stiff support system (e.g. slurry walls, tangent walls, etc.) and other means of support of excavation (such as soil grouting). The requirement may also include restricting the spacing of soldier piles to 4 feet maximum, and restricting the spacing of supports (rakers, tiebacks, etc.) to 8 feet maximum. It is recommended that the ODC discuss the support of excavation within ten (10) feet (horizontal dimension) of structures with WMATA before commencing such support design.

- B.** Soldier piles generally shall be designed as simply supported beams, spanning between points of support. In analyzing intermediate stages of excavation, the soldier pile shall be assumed to be continuous across the lowest level of bracing. The embedment length of soldier piles below the design subgrade shall be analyzed for the horizontal resistance required to provide a support point below the subgrade. The maximum horizontal resistance on the soldier beams flange may be assumed to be three times the ordinary passive pressure computed for the width of the flange, or the width/diameter of pre-augured hole when filled with a minimum of 3500 psi concrete, but not to exceed the passive pressure based on the spacing of soldier piles. The minimum embedment length shall be ten (10) feet.
1. For soldier piles terminating in sound or relatively sound rock and subgrade is located below the top of rock, with minimum 3 feet clearance from the excavation edge, minimum embedment in rock shall be five feet.
  2. For soldier piles terminating in weathered rock and subgrade located below the top of rock within 10 feet, minimum embedment in rock is 3 feet below subgrade or 3 feet below auger refusal. The soldier pile shall be laterally supported in an approved manner before the start of rock excavation.
  3. For soldier piles terminating in weathered rock and subgrade located at 10 feet or greater below the top of rock, minimum embedment in rock is 5 feet below auger refusal. The soldier pile shall be laterally supported in an approved manner before the start of rock excavation.
- C.** All structural steel members in the excavation support structure should be sized using **Allowable Stress Design** (Working Stress Method) in the AISC Steel Construction Manual, latest edition. Neither the design axial stress can be reduced nor the permissible allowable bending stress and combined stress ratio be increased for the excavation support structure. SOE design calculations must consider the effects of combined axial, torsional, and flexural loads in the structure and its elements.

Bracing members, such as struts, corner braces, cross struts, rakers, etc., should be designed, other than self-weight, for an additional lateral load, equal to 2% of maximum design axial load and imposed on bracing members in both lateral directions, applied to produce maximum flexure on the members.

The stability of laterally unsupported members and unsupported span lengths should be considered in the design of the supporting members. The use of pin

piles or lacing may be required provided the above stress requirement is not satisfactory.

The pin pile design is presumed as 2% of maximum design axial load of abutted bracings in both horizontal and vertical directions. The lacing design load is assumed to be 2% maximum axial load of abutted main support members.

**D.** The structural support system design must recognize the effects of all loads resulting from construction equipment, construction trailers, supported utilities, stockpiled materials, cranes, concrete trucks, and non-underpinned buildings adjacent to the excavation. The loading shown in Plate A-6A of [Appendix 3](#) will provide the minimum surcharge loading.

**E.** Soldier piles shall ordinarily be spaced from four to seven feet on centers. A maximum spacing of eight feet on centers will be allowed where soil conditions are granular. Timber lagging shall have a minimum flexural stress of 1100 pounds per square inch and three inches minimum thickness for soldier piles spaced 7 feet apart and for excavated depths of up to 25 feet. Timber lagging, four inches thick, shall be used in excavations below 25 feet. For other pile spacing, conditions and types of lagging the design details shall be submitted for approval. Soldier pile and lagging walls shall be analyzed in accordance with requirements presented herein.

**F.** The vertical spacing of bracing tiers shall not exceed 12 feet center to center. The maximum length of unsupported soldier pile between the surface of the ground and the first brace shall not exceed six feet. Deflections in the soldier piles shall not exceed  $\frac{1}{2}$  inch. The soldier pile bearing capacity and the soldier pile deflections shall be calculated and included in the calculations.

Cantilevered soldier piles may be used for shallow excavation provided the maximum cantilever length does not exceed 7 feet and the maximum deflection does not exceed  $\frac{1}{2}$  inch.

**G.** Wales may be designed as simply supported beams, spanning between points of support, or as continuous across points of support, depending upon, fabrication and installation details. Axial load shall be considered in the design of wales, as appropriate. Wale deflection shall not exceed  $\frac{1}{4}$  inch.

**H.** Struts and Rakers shall be designed for axial load, torsional and flexural loads as appropriate. Struts and Rakers shall be laterally braced in accordance with the requirements of the current edition of the AISC Steel Construction Manual. Strut and Raker sections shall be chosen to limit deflections to the above requirements.

In addition, for support systems in which braces are installed between opposite sides of excavation (cross-lot struts), design and construct support on both sides to obtain comparable restraint and rigidity.

**I.** Tiebacks shall be deformed steel bars with a minimum guaranteed ultimate tensile strength (GUTS) of 150,000 pounds per square inch or seven-wire stress relieved steel strand for pre-stressed concrete with a guaranteed ultimate tensile stress (GUTS) of 270,000 pounds per square inch. Tiebacks must be installed and tested in accordance with Section 3.7.



The ODC shall ensure that minimum clearances of tiebacks free length and the anchored length shall be at least 5 feet and 10 feet, respectively from the existing WMATA facilities. Tieback construction procedures shall take every precaution to minimize ground loss. WMATA shall be notified for any changes to the tiebacks / anchors which are made to clear existing utilities (prior to construction).

- J.** When using corner / diagonal bracing, and when the wales do not transfer the load to the other end, analysis shall include calculations required to determine reaction dissipation into the support of excavation wall (soldier piles, slurry walls etc.) on the sides of excavation. If corner bracing is proposed with wales connected at the corners, the corner connection of the wales must be completed after preloading the corner/diagonal bracing.
- K.** Details should be provided on the shop or working drawings indicating how the tieback, strut, or raker loads are to be transmitted from the supporting member through the waler to the soldier pile. Details should include bolted and welded connections, web stiffeners and brackets, dimensions of raker heel blocks, strut lacing, pin piles, jacking lugs and other special details of construction. Illustrate connection details indicating how the forces from the corner braces would be transmitted and dissipated or balanced through the soldier piles and/or walers. Calculations are required for each listed item.
- L.** The sequence and method of construction shall be included on the shop or working drawings. Procedures shall be included for wedging or jacking rakers, loading tiebacks and preloading struts. Details of wedging and jacking to maintain tight contact for all bracing members shall be shown.

  - 1.** Tiebacks shall be preloaded to 140% of the maximum design load and locked off at 100% of the maximum design load.
  - 2.** Struts and rakers **not** used for slurry walls, tangent and secant piles, shall be preloaded to 50% of the maximum design load.
  - 3.** Struts and rakers used to support slurry walls, tangent and secant piles, shall be preloaded to 100% of the maximum design load.
  - 4.** Tieback, raker, and strut loads shall be shown on the shop drawings.
  - 5.** Excavation shall not be allowed to proceed for more than two feet below the point of lateral support before the main bracing members are installed and preloaded. Earth berms are permitted when required for the installation of rakers and heel blocks. Slopes on the berms are to be no steeper than one vertical to one and one half horizontal.
- M.** Bearing capacity for heel blocks shall be analyzed based on accepted methods of analysis of inclined footings, such as are described in the Reference Manuals as listed at the end of this sub-section.

A minimum safety factor of 3 shall be applied to obtain the allowable bearing capacity. The heel block spacing and design shall consider the interaction of the

heel blocks on the supporting soil. Suitable reductions in the allowable bearing capacity of the soil shall be made to account for any overlapping soil stresses.

1. Bowles, Joseph E. "Foundation Analysis and Design", Fourth Edition or Fifth Edition, Chapter 4, Bearing Capacity of Foundations, McGraw-Hill Companies, Inc., New York, N.Y.
  2. United States Naval Facilities Engineering Command, Design Manual 7.02 (NAVFAC DM 7.02), 1986, Foundations and Earth Structures, USNAVFAC, Alexandria, Virginia.
  3. Ralph B. Deck, Walter E. Hanson, and Thomas H. Thorkbur (1974), Foundation Engineering, Second Edition, John Wiley & Sons, Inc.
- N.** Steel sheet piles used adjacent to WMATA structures shall be hot-rolled, steel sheet piles. Lateral soil pressures for sheet piles must be based on undrained condition. For adequate stiffness Z-profile sheet piles are recommended. For sheet piles terminating at top of rock above the base of excavations, the sheet piles shall be laterally supported in an approved manner before the start of rock excavation. Sheet pile deflections shall be calculated and included in the submissions; maximum allowable deflection of sheet piles is ½ inch.
- O.** Slurry (diaphragm) walls consist of structural cast in place concrete walls constructed by tremie placement of concrete in a pre-excavated, slurry filled trench. Slurry wall panels excavated adjacent to WMATA structures shall have a minimum thickness of three (3) feet and maximum length of ten (10) feet. Slurry wall bearing capacity and slurry wall deflections shall be calculated and included in the submissions. Slurry walls shall be analyzed in accordance with the requirements presented herein. For slurry walls terminating at top of rock above the base of excavations, the slurry wall shall be keyed into the rock and laterally supported in an approved manner before the start of rock excavation.
- P.** Secant or tangent pile walls consist of a line of bored piles to form a continuous wall. If the bored piles are tangent or contiguous to each other the wall is tangent pile wall. If the bored pile elements overlap to form an interlocking wall, the wall is called a secant pile wall. Piles shall be reinforced with reinforcing bar cages or structural steel shapes. Secant or tangent pile wall bearing capacity and deflections shall be calculated and included in the submissions. Secant and tangent pile walls shall be analyzed in accordance with the requirements presented herein. For secant and tangent pile walls terminating at top of rock above the base of excavations, the pile wall shall be laterally supported in an approved manner before the start of rock excavation.
- Q.** NATM Shafts may be used with prior approval of WMATA. NATM shafts are shafts constructed using the New Austrian Tunneling Method (NATM). NATM shafts can be constructed in soil and in rock.

NATM shaft construction in soil entails excavation in lifts ranging from three (3) feet to five (5) feet in height. Each lift is supported by a lining girders, normally lattice girders, embedded in shotcrete (sprayed concrete). For all NATM shafts submit supporting design calculations; proposed excavation and support

procedures; proposed groundwater control measures; shotcrete design mix and field trial information; shop drawings for lattice girders, including connection details, rock reinforcement, and welded wire fabric, including details for intermediate anchors between rock reinforcement and lattice girders; concrete mix; formwork design; and concrete placement and consolidation methods.

### **3.7 Support Systems with Tiebacks**

- A.** Install tieback system in accordance with approved working drawings. Install anchorage in soil no closer than a plane extending upward at an angle of 45 degrees to the horizontal from outer limit of lowest depth of excavation. ODC will have to certify that the boundary survey for the proposed tieback / support systems have been tied into WMATA's control coordinates. WMATA's survey control may be located on as-built plans.
- B.** Stress tiebacks to proof loads equal to 140 percent of maximum design load and maintain proof load for 30 minutes prior to reducing to design load. Reject tiebacks which lose more than five percent of proof load during 30-minute period.
- C.** Apply proof loads in increments of five tons at one-minute intervals and provide means to measure load application within accuracy of plus-or-minus five percent.
- D.** After reducing tieback load to design load, encase anchors in grout maintaining design load until anchors are fixed in place.
- E.** In transfer of loads from jacks to support system, use fixation method which will limit load loss to no more than five percent of design load.
- F.** Provide and maintain convenient access and appropriate means to accomplish these observations.
- G.** Preliminary and Creep Tests On Tiebacks:
  - 1.** Reapply proof loads equal to 140 percent of design load at each level of support in excavation on first installation on each side of excavation at horizontal intervals not exceeding 500 feet and wherever there is significant difference in soil in which tiebacks are installed.
  - 2.** As specified for proof loading, apply proof loads in increments of five tons at one-minute intervals. Provide means to measure load applications with an accuracy of plus-or-minus five percent of design load. Maintain proof load for 24 hours prior to reducing it to design load.
  - 3.** Make records of axial movement with incremental applications of load as well as amount and time of load fall-off with no pumping of jack or axial movement during the 24-hour period that proof load on tieback is maintained.
  - 4.** If during the 24-hour period axial deformation of tieback system exceeds 0.02 inch or decrease in jack pressure without pumping is more than five

percent after correcting for temperature changes during the test period, redesign tieback system to satisfy requirements.

### **3.8 Shop Drawings/Project Drawings**

- A.** Copies of the loading records for struts, rakers, tiebacks and the test reports on tiebacks shall be provided to WMATA. The loading records and the test reports shall be signed and sealed by a registered Professional Engineer, licensed to practice in the jurisdiction where the work is being performed.
- B.** Calculations shall be provided for all components of the structural support system required for adjacent construction impacting WMATA's ZOI. The calculations and the drawings shall be signed and sealed by a Professional Engineer, licensed to practice in the jurisdiction where the work is performed. The calculations submitted shall include the following:
  - 1.** A concise statement of the problem and the purpose of the calculation.
  - 2.** Input data, applicable criteria, clearly stated assumptions and justifying rationale.
  - 3.** References to articles, manuals, and source material must be furnished with the calculations.
  - 4.** References to pertinent codes and standards.
  - 5.** Sufficient sketches or drawing references for the work to be easily understood by an independent reviewer. Diagrams indicating data (such as loads and dimensions) shall be included along with adequate sketches of all details not considered standard by WMATA.
  - 6.** The source or derivation of all equations where they are introduced into the calculations.
  - 7.** Numerical calculations shall be clearly shown, orderly and legible; all in English units.
  - 8.** Results and conclusions.
- C.** Include sequence and method of construction on the design drawings. Show details and procedures for wedging or jacking rakers, loading tiebacks and preloading struts and corner braces/struts. The details of wedging and jacking should be such as to maintain tight contact for all bracing members. Tieback, raker and strut loads, sizes and locations shall be shown on the design drawings.
- D.** Maximum size of each sheet will depend on the projects engineering design scale. Minimum requirements for each drawing:
  - 1.** Number and title of the drawing.

2. Date of the drawing and revision date(s).
3. Name of project.
4. Engineering scale.
5. Name of ODC submitting the drawing.
6. Clear identification of contents and location of the work to include delineation of WMATA easements relative to the adjacent work.
7. Title and number of referenced specification sections.
8. Signed and sealed by engineer licensed in the jurisdiction of the proposed project.
9. Other pertinent drawing criteria / documentation:
  - i. Fabrication, erection, layout and setting drawings.
  - ii. Complete list of materials for construction on / directly adjacent to WMATA property.
  - iii. Schedules.
  - iv. Manufacturer's drawings.
  - v. Wiring and control diagrams, as applicable.
  - vi. Catalog cuts or entire catalogs.
  - vii. Descriptive literature
  - viii. Performance test data.
  - ix. Material samples (as required).

**E.** When computer programs are used to perform calculations, a "User's Manual" shall accompany the calculation. The "User's Manual" shall also include a verification section. The verification section shall describe the verification methods and how they cover all the permitted options and uses of the program.

### **3.9 Limitations on Construction**

- A.** The following construction activities are not permitted within the specified limits of existing WMATA facilities:
1. Excavation under WMATA structures is prohibited, except for access for underpinning.

2. Tunneling under WMATA structures/facilities and tracks is prohibited, unless prior documented approval of WMATA is obtained.
3. Excavation within 10 feet of existing WMATA facilities is prohibited (the 10 feet shall be measured, in plan, from the outside face of the WMATA structure to the crest of slope of any unsupported excavation), unless:

- i. The existing WMATA excavation support system, that was used for construction of the WMATA facility (i.e. soldier piles) can be utilized, with prior approval of WMATA, if the soldier piles can be located, and can be pre-loaded to the required stress level during excavation, without over stressing the WMATA structure.

The capacity of the existing soldier beams shall be based on an allowable flexural stress of 20 ksi. In addition if the soldier beams are corroded or if there is any loss in section, allowance should be made for it. It is essential that the use of existing WMATA excavation system shall not damage the existing waterproofing system; therefore, it is necessary to grout the area between the existing soldier piles to ensure no impact on the existing waterproofing.

Existing soldier piles shall be located by test pit or by geophysical methods supplemented by test pits and the information shall be submitted to WMATA for review.

In addition, when the support of excavation is nearer to WMATA structure or cut-and-cover tunnel than five (5) foot laterally, and is nearer to WMATA bored tunnel than ten (10) foot laterally, and the subgrade of the excavation is below an elevation which is five (5) feet above the bottom of WMATA structure, then provide a rigid support of excavation system like slurry walls, tangent walls or secant walls. Reference Plate A-9 of [Appendix 3](#).

As a rule, WMATA discourages the use of the existing/previous excavation support system, and the use of the existing/previous support system will be at the sole discretion of WMATA. When the ground conditions warrant, use of ground stabilization with flexible support of excavation, in lieu of rigid support of excavation, may be approved by WMATA in its sole discretion.

- ii. An excavation support system, conforming to the requirements of this Manual, shall be installed to protect existing WMATA facilities.
4. Installation of pre-augured piles within five (5) feet (horizontal dimension) of the bored tunnel liners.
5. Pile driving within 25 feet (horizontal dimension) of WMATA structures, and tracks.

6. Blasting shall not occur within 100 feet of WMATA structures without prior approval of WMATA, and unless test blasting that generates a particle velocity-scaled distance relationship indicates that peak particle velocity (PPV) measured at the minimum separation distance between the WMATA structure and proposed blasting locations shall not exceed 2.0 inches per second. (See U.S. Army Corps of Engineers ETL 1110-1-142, Engineering and Design – Blasting Vibration Damage and Noise Prediction and Control, available from [www.usace.army.mil](http://www.usace.army.mil)). A blast-monitoring program shall be provided to verify compliance.

Measurement of PPV in excess of the requirement stated herein shall require the suspension of blasting operations and revision of blasting procedures to reduce PPV to acceptable limits.

### 3.10 Installation Criteria

- A. Piles located within 25 feet (horizontal dimension) of existing facilities shall be installed in pre-augured holes. Pre-augured holes shall be protected by either steel casing or drilling mud / slurry to keep the drilled hole open and to prevent ground loss.

Furthermore, these piles shall be embedded at least 10 feet into the strata below the ZOI of the WMATA structure, or should be embedded at least ten (10) feet below the subgrade level as approved by WMATA. The drilled hole around the pile shall be filled with 3500 psi concrete from pile tip to subgrade, and filled with lean concrete from the subgrade to the surface of the ground. Concrete shall be placed using a tremie.

Struts and rakers used to support slurry walls and tangent or secant pile walls shall be preloaded to 100% of their maximum design load. Struts and rakers for steel soldier piles with lagging and sheet pile walls shall be preloaded to a minimum of 50% of their maximum design load (or for any other support system approved by WMATA). When using raker bracing systems, a reduced passive resistance shall be applied for temporary berms during partial excavations.

- B. For tieback installation, the free length and the anchored length shall be at least five (5) feet and ten (10) feet, respectively, from the existing WMATA facilities. Tieback construction procedures shall take every precaution to minimize ground loss. (See Section 3.7 for other requirements of tie-back installation)
- C. A system for monitoring the vertical and horizontal movement of the support of excavation structure shall be submitted for approval.

### 3.11 Underpinning – General

- A. Underpinning of WMATA structures is required when the WMATA structures fall within the 1:1 influence line of the adjacent construction, see Plate A-3A and Plate A-3B in [Appendix 3](#). The underpinning will be designed to meet the allowable compressive / bearing strength of the soil under the WMATA structure. The allowable bearing capacity shall be determined by applying a safety factor of 3 to ultimate bearing capacity or use allowable bearing pressure contained in [Appendix](#)

[3](#) Table No. 3-3. Alternately, compute ultimate bearing capacity in accordance with procedures in US Naval Facilities Design Manual, NAVFAC DM7.2, Foundations and Earth Structures, Chapter 5, Deep Foundations, ignoring friction and adhesion.

- B.** Location and type of underpinning shall be clearly shown on the excavation support system drawings. When the ground conditions warrant and the WMATA structure load can be supported below the 1:1 slope influence line (Plate A-3B in [Appendix 3](#)), use rigid support of excavation or ground stabilization with flexible support of excavation, in lieu of underpinning if approved by WMATA.
- C.** All proposed underpinning pits shall be clearly shown on the excavation drawings. The size and depth of the pits shall be indicated as well as the stratum into which the underpinning pit is to be excavated. The bearing pressure of the stratum shall be shown together with the lowest pit bearing elevation expected. Details shall be provided for load transfer between underpinning piers and existing foundations (dry packing, etc.).
- D.** Show on the drawings the pit excavation sequence.
- E.** Provide calculations as necessary in support of the drawings.
- F.** Jacked Piles and Bracket Piles may be used for underpinning with WMATA's prior approval.

### **3.12 Jacked Piles**

- A.** Jacked piles may be used for underpinning WMATA structures if installed in accordance with the following criteria.
  - 1.** Approach pit and pile locations shall be shown clearly on excavation support drawings. Submit design calculations for temporary shoring of approach pits. Use hydraulic jacks capable of developing sufficient capacity to jack piles to specified load. Submit recent certified calibration data of pressure gauge and jack as a combined unit. Calibration shall be performed within 30 calendar days of start of field operations.
  - 2.** Use open-end steel pipe shells. Jack to levels/depths shown plus any additional penetration required to develop design working load of pile. Jack pile shells by distributing reactions over existing footing or structure so as to prevent over stressing or damaging the footing or the structure.
  - 3.** Furnish proposed monitoring system. During installation of jacked piles check column or wall movement under each footing. If movement exceeds 1/32 of an inch, immediately cease operations and report the situation to WMATA.
  - 4.** Submit complete procedure for jacked pile installation to WMATA for review.



**B.** Installation of Jacked Piles

1. Clean out pile shells to within one foot of pile tips. Remove obstructions by drilling or spudding, not blasting. When pile tip is below groundwater table, maintain elevation of water inside pile shell at or above elevation of groundwater table, except during inspection of pile or as otherwise approved.
2. After cleaning and prior to filling shell with concrete apply load equal to the percentage of design working load, shown on the drawings, unless otherwise directed, to each empty pile shell and maintain until there is no measurable settlement over a one hour period.
3. Fill the accepted steel pipe with concrete by either placing concrete continuously by approved tremie or underwater bucket, or by placing five foot seal underwater, dewater pile shell and place remainder of concrete continuously in the dry.
4. After concrete within pile has set for at least 24 hours, test pile by jacking to 150% of design working load of the pile. Maintain load until there is no measurable settlement of pile over one hour period. Details and arrangement of pile shell load test and pre-loading are at the option of the Contractor and subject to WMATA approval. Inserting steel beam on top of pile and jacking or wedging firmly against pile and foundation, and encasing it in concrete is an acceptable solution.

**3.13 Bracket Piles**

- A. Bracket piles shall be installed in pre-drilled holes. Pre-drilled holes shall be protected by casing or by drilling mud or slurry. Pre-drilled holes shall be backfilled with lean concrete to minimize ground loss.
- B. Provide design calculations for pile and bracket.

**3.14 Construction Adjacent to WMATA Tunnels**

Tunnel Analysis Criteria - All existing tunnels, shall be considered to be already under the long term loads. Any changes in the loading, due to adjacent excavation and construction, shall not increase stresses and deformations in the WMATA tunnels.

- A. For WMATA bored tunnels: If new construction is adjacent to or over existing WMATA bored tunnels, establish earth pressure diagrams based on WMATA's design criteria and soil properties in Table No.3-3. Establish the short term and long term loading conditions that will result from the adjacent construction. Adjacent construction activities shall not increase stresses and deformations in the existing WMATA tunnels. Any additional loadings must be transferred outside and below the tunnel structure unless expressly permitted by WMATA.
- B. For WMATA cut and cover tunnels and any other underground structures: If new construction is adjacent to or over existing WMATA cut and cover tunnels, establish

earth pressure diagrams based on WMATA's design criteria and soil properties in Table No.3-3. Establish the short term and long term loading conditions that will result from the adjacent construction. Adjacent construction activities shall not increase stresses and deformations in the existing WMATA tunnels and other underground structures. Any additional loadings must be transferred outside and below the tunnels and other underground structures unless expressly permitted by WMATA.

**C.** The structural check of existing WMATA bored tunnel liners or cut and cover tunnel sections must include calculations for the following:

1. Stresses in the tunnel structure/liner.
2. Tunnel section distortion.
3. Lateral shift of tunnel.
4. Opening of the joints and possibility of water leakage at bolted joints. Bolt stresses shall be calculated.

The support of excavation system of a large number of existing WMATA cut and cover, tunnels consisted of a soldier pile and lagging system. This support of excavation system was frequently left in place. When this system is encountered, it shall not be removed.

**D.** Additional Requirements for Excavation Adjacent to Underground WMATA Tunnel Structures and Facilities

1. For excavations adjacent to WMATA underground structures within the WMATA ZOI, provide an excavation support system conforming to this Manual's requirements. For excavations within a plan distance of five (5) feet from cut and cover, and ten (10) feet from the bored tunnel, and when the excavation subgrade extends below the level which is 5 feet above the bottom of tunnel use a rigid / stiff support of excavation system with slurry walls, tangent piles or secant piles. Reference Plate A-9 in [Appendix 3](#).
2. Any other system, if a prior approval of WMATA is obtained, may have to be designed for a higher stiffness factor and requirements, based on a case by case basis, at the sole discretion of WMATA. When the ground conditions warrant, use of ground stabilization with flexible support of excavation, in lieu of rigid support of excavation may be approved by WMATA at its sole discretion.
3. WMATA tunnel structures shall be underpinned per the requirements of this Manual and as contained in [Appendix 3](#) Plate A-3A and Plate A-3B. Structure movement shall be monitored during excavation in accordance with monitoring plan.

### **3.15 General - Construction adjacent to WMATA At-Grade Roadway and/or Facilities**

- A.** Work to install casings, drive tunnels and micro tunnels or construct other facilities under WMATA tracks shall normally be done continuously. If the facility is to be installed near the surface where ground borne vibrations or projected settlement / heave may be a problem, then the work will be restricted to non-revenue hours.
- B.** A subsidence detection plan and a detailed tunneling schedule will be required prior to scheduling any such operation adjacent to WMATA structures. Provide detailed description and design of underground crossing (tunneling, micro tunneling etc.).
- C.** A geotechnical or soils report with a proposed dewatering plan shall accompany the plan submitted for an underground crossing of the WMATA at grade operating roadway, or excavation adjacent to the WMATA at-grade roadway or operating roadway. Any ground improvements, like grouting, necessary for the underground crossing should be specified in the geotechnical / soils report.
- D.** No drainage, either surface or subsurface, is to be diverted into WMATA drainage systems from adjacent facilities without calculations to verify that the WMATA facilities will not be overloaded. Specific approval by WMATA is required for these diversions.
- E.** When construction is adjacent to WMATA surface roadway and will impact the WMATA security fence, details shall be provided for the proposed modifications to the WMATA security fencing required to accommodate the project. The drawings shall include the details of temporary and permanent intrusions into or occupancy of WMATA's right-of-way. WMATA will require that the right-of-way is protected at all times and any modifications to current right-of-way fencing will be completed during non-revenue hours. WMATA will also require that all fencing (temporary or permanent), which protects the operating / energized roadway, will meet the standards and specifications provided in the WMATA's Manual of Design Criteria.
- F.** WMATA will require additional protective design measures for modified grade separation between existing facilities and the proposed construction. Such additional design measures, at the ODC's time and expense, may include, but are not limited to; 1) implementation of additional intrusion detection warning (IDW) system along its right-of-way fence, 2) increased vertical height of the right-of-way fence, and/or 3) crash barrier protective devices. The WMATA intrusion detection warning (IDW) system on the security fence must be maintained at all times during adjacent construction. WMATA has standard design criteria for crash barrier walls. This information is available from WMATA upon request.
- G.** Specific protective measures will be required for project activities which may impact the operating roadway. These measures may include protective screening and overhead protections, as well as, restrictions on crane placement and movements. Requirements will be addressed on a project specific basis.

### **3.16 Tunneling / Boring under WMATA Roadway**

The following is based on assumption that the proposed tunnel(s) are smaller than 8 feet in diameter. Tunnels larger than 8 feet in diameter will require a preliminary presentation be made to WMATA prior to proceeding with final design.

- A.** The plans and specifications for the proposed tunnel shall be submitted for review and approval in advance of construction.
- B.** Monitor WMATA track/subgrade movement during underground crossing or excavation in accordance with monitoring plan developed in compliance with WMATA requirements.

At a minimum, subsidence detectors are required along the centerline of the tunnel. Heaving or subsidence of the WMATA at-grade roadway is not permitted. Survey roadway above the underground crossing or adjacent to the excavation and submit survey data to WMATA prior to start of work.

A contingency construction plan is required to allow adjustment of track to compensate for movements in accordance with, and to the track geometry tolerances specified in the WMATA Track Standards Manual. WMATA Track Standards Manual is available upon request. Also, for Monitoring Threshold or Limiting values of Track / Rail movement, see Section 4.8 for details.

### **3.17 Excavation Adjacent to WMATA Roadway / Right-of-Way and At-Grade Facilities**

- A.** Excavation support systems adjacent to surface sections / at-grade roadway of Metrorail shall be designed when roadway is located partially or entirely within the WMATA ZOI.
- B.** Batter piles that require the pile to lean towards or over WMATA Roadway shall be driven during non-revenue hours. Plumb and batter piles that lean away from the WMATA Roadway may be driven during non-peak revenue hours. A WMATA Flagman will be required for all pile auguring within 25 feet (horizontal dimension) of the Metrorail fence and/or structures. Fixed-leads are required for all pile driving where fouling or encroachment onto WMATA property is possible. The ODC will be held responsible financially for any damage to WMATA structures, to include any loss of revenue operations due to detrimental impact from the adjacent construction. This would include, but not limited to, restoring WMATA tracks and/or structures to new construction standards due to the movements and displacements caused by the adjacent construction work, and alternate service in the event of disruption to scheduled revenue service.

### **3.18 Construction Adjacent to WMATA Aerial Roadway/Structures**

- A.** For excavations adjacent to WMATA aerial structures, an excavation support system conforming to requirements for excavations adjacent to aerial facilities must be provided, when the facility is located partially or entirely within the WMATA ZOI.

- B.** For aerial structure foundations that fall partially or entirely above the adjacent excavation influence lines as shown in [Appendix 3](#) Plate A-2E, underpinning shall be provided. Underpinning for WMATA Aerial structures must be extended to bear at least ten (10) feet below the ZOI line. Structure movement shall be monitored during excavation in accordance with monitoring plan developed in compliance with the requirements of this Manual. As coordinated with WMATA, the ODC will be held responsible financially for any damage to WMATA structures, to include any loss of revenue operations due to detrimental impact from the adjacent construction, restoration and alternate service in the event of disruption to scheduled revenue service.

### **3.19 Structures Built Directly Above or Adjacent to WMATA Roadway and Facilities**

- A.** Wind loads shall be considered for any adjacent structure to be built above or adjacent to existing WMATA facilities. Design loads must satisfy minimum requirements of the local jurisdictional codes and must be not less than 50 pounds per square foot of the projected area of the structure for overall design capacity (on a vertical plane at right angles to the wind direction). For design of components, this load may be divided into the ratio of 60% for the windward face and 40% for the leeward face.
- B.** New structures designed for vehicular traffic must have adequate provisions and strength to prevent failure of the structure, and incorporate protective measures to guard against objects or debris from entering WMATA Roadway.

### **3.20 Blasting / Demolition Criteria**

The following criteria will apply if the proposed rock blasting is in the WMATA ZOI. The ODC must verify the proposed blasting impact with WMATA via shop drawing submittals and blasting plan.

- A.** The peak particle velocity imparted to existing WMATA facilities caused by blasting shall not exceed 2 inches per second in all cases.
- B.** If blasting is to be used in the excavation, the following information shall be provided for review and approval:
  - 1.** The ODC will provide WMATA with a site plan to illustrate blasting relative to WMATA structures if a proposed rock blasting operation is within WMATA's ZOI (100 feet).
  - 2.** A blasting plan, which shall include the size, depth and spacing of the blast holes, the blasting agent, the average charge per hole, the blast monitoring program and the blast monitoring equipment and seismographs.
  - 3.** No more than one hole shall be fired in the same delay period.
- C.** Test blasting in WMATA's ZOI is required, starting from 100 feet horizontal distance from WMATA's facilities or utilities. A test blast must start with a low weight per charge for the initial blast, which will serve as a "test blast". Depending on results of seismograph reading after the test blast, an increase in the weight of

the charge may be allowed. The maximum weight of charge shall not exceed 5 pounds /hole/delay.

### **3.21 Certification and Documentation**

- A.** Submit a copy of request to utility companies owning or agency controlling services and appurtenances affected by demolition work for discontinuance of services along with certificates of severance. The ODC must ensure that WMATA's facilities are not impacted by demolition operations whether due to adjacent utility damage and/or temporary service discontinuation.
- B.** Submit a copy of the demolition permit from the jurisdictional agency and owner.

### **3.22 Blasting Operations / Administrative Procedures / Prior Blasting Notifications**

- A.** Blasting operations shall be restricted to the hours of 9:30 AM to 3:30 PM weekdays. A request may be submitted for blasting outside of these hours for review and approval. Seismograph instrumentation is required to monitor the blasting operation in the vicinity of existing WMATA facilities. Seismograph instrumentation should be installed inside or on the WMATA facilities as close as to the blasting as feasible.
- B.** Once the blasting plan is approved, the ODC is to notify the Construction Inspection Facilitator in accordance with the approved WMATA Blasting Notification Procedures Plan developed for each project.
- C.** The ROCC Superintendent shall also be contacted five minutes before each blasting event so that train movement through the area can be halted temporarily, when WMATA deems it necessary. Train movement would generally be required to be stopped during test blasts. Normally the movement of trains will not be required to halt if the peak particle velocity recorded by the seismograph is below 2 inches per second. Blasting may only be conducted with the approval, via radio or telephone, by the ROCC Superintendent or his designee. If problems are experienced, WMATA monitoring personnel on site are authorized to immediately stop the blasting and notify the ROCC (202-962-1652).
- D.** Procedures for obtaining WMATA support and WMATA supervision of ODC personnel required for the location of a seismograph in an underground tunnel or station must be submitted for approval prior to initiation of blasting activities. The ODC requesting support of WMATA personnel will be required to compensate WMATA for the personnel costs associated with the support.
- E.** Roadway entry requests, track rights requests, Roadway Worker Protection safety training, operational support and Site Specific Work Plans for WMATA structural monitoring program(s) are to be as required by this Manual. The Blasting Schedule must be included in the WMATA weekly "General Order" to enable internal communication of such activity with other WMATA offices (such as Rail Transportation / Station Managers).

- F. Use of any WMATA land or right-of-way will require a real estate permit. The WMATA Office of Real Estate and Station Planning will establish the fair market value or fee for the use or temporary lease of WMATA property.

### **3.23 Civil Criteria**

- A. Refer to WMATA's Civil Criteria ([Appendix 6](#)) for submission of real estate plat and survey documentation.
- B. Refer to WMATA's Design Criteria for standard fencing plans, details, and specifications.
- C. Refer to WMATA's Design Criteria for at-grade standards for installation of right-of-way utility markers.
- D. WMATA's Design Criteria, Standard Design Drawings and Specifications are available on CD. Request must be made in writing to the CE who will issue the CD in accordance with current WMATA Policies and Procedures.
- E. Underground utilities on WMATA property being proposed for abandonment shall be either removed or filled with permanent flowable fill. This requirement shall be identified on all design plans.

### **3.24 Mechanical Criteria**

- A. Existing services to WMATA facilities, including chilled water and condenser water piping, potable and fire water, fire stand pipes, drainage pump stations, discharge pipes, and storm and sanitary sewers, are not to be interrupted nor disturbed without written approval of WMATA. The ODC must ensure that future access to WMATA utilities is maintained and illustrated in the proposed design modifications.
- B. Surface openings of ventilation shafts, emergency exits serving WMATA underground facilities, and ventilation system openings of surface and elevated facilities shall not be blocked or restricted. Construction dust shall be prevented from entering WMATA facilities.
- C. Hot or foul air, fumes, smoke, steam, etc. from adjacent new or temporary facilities shall not be discharged within 25 feet of existing WMATA ventilation system intake shafts. Tunnel ventilation shafts are both intake and discharge structures.
- D. Clear access for the fire department to the WMATA fire standpipe system shall be maintained at all times. Construction signs shall be provided to identify the location of WMATA fire stand pipes. The ODC must contact WMATA's assigned CE and Field Facilitator at least forty-eight (48) hours in advance for coordination of any approved interruption to fire standpipe water service or water service.
- E. Modifications to existing WMATA mechanical systems and equipment, including ventilation shafts, required by new utility connections into the WMATA System, shall be permitted with approval by WMATA, providing:

1. The ODC submit design calculations, drawings, specifications, catalog cuts and any other information necessary to fully describe the proposed modification.
2. If the ODC wishes to permanently enclose any WMATA fan, emergency exit, exhaust/ventilation units, the enclosure must be designed with appropriate clearances and openings to accommodate the air circulation volumes equal to the design capacity of the particular shaft. The proposed construction above WMATA's ventilation units must include projected air flow calculations accounting for the specific shaft type. This information shall be submitted to WMATA for approval.

The calculations shall be signed and stamped by a licensed mechanical engineer practicing in the jurisdiction where the construction is proposed. A permanent emergency path shall be provided and maintained at all times between the nearest public street and the shaft to accommodate fire and rescue, WMATA emergency ingress / egress, and WMATA maintenance access. Panic hardware is to be provided on all door(s) / gate(s) servicing the proposed enclosure.

3. The ODC obtains a WMATA Real Estate Permit.
4. At the option of WMATA, the ODC may be requested to perform the field tests necessary to verify the adequacy of the modified system and the equipment performance. Where a modification is approved, the ODC shall be responsible for maintaining original operation capacity of the equipment and the system impacted by the modification.

### **3.25 Electrical and Communication Criteria**

- A. No interference with existing WMATA ductbanks for electrical services shall be allowed for:
  1. 13.8KV service from PEPCO
  2. 34.5KV or 13.8KV service from Virginia Power
  3. 480V service to Chiller Plant from PEPCO, Virginia Power or from WMATA Substations.
  4. 480V service to lighting in Parking Lots, Kiss and Ride areas, and 120V service to Bus Shelters.
- B. If ductbanks are affected by the adjacent construction, all information must be submitted to WMATA and utility company for review and approval.
- C. For the non-wayside work impacting WMATA facilities a scheduled power outage and WMATA support requests must be submitted to WMATA for:
  1. All emergency /corrective / modification work as reviewed, coordinated and approved by WMATA, and



2. Any work adjacent to energized cables and other electrical equipment. Except for emergency situations, the ODC must comply with scheduling of power outage(s) and escort personnel request procedures.
- D. No interference with existing WMATA ductbanks shall be allowed for:
1. Telephone cables from Verizon
  2. WMATA train control and communications cables.

### **3.26 Redesign of WMATA Facilities**

Refer to Section 5.7 for other related information / rules.

- A. The design for relocation or modification to existing WMATA chiller plants, drainage pumping stations, parking garages, parking lots, or Kiss & Ride areas, escalator passageways, vent shafts, bus shelters and any other facilities shall be done in accordance with the WMATA Design Criteria, Directive Drawings and Standard Specifications. To minimize interruption of WMATA operations, a construction phasing plan shall be developed and submitted for approval.
- B. Proposed relocation of light fixtures, if any, shall be submitted for WMATA approval. Temporary lighting shall be provided in the interim.
- C. Existing ground-grids and ground conductors from ground-grids to WMATA facilities shall not be disturbed. No digging or cutting into existing WMATA facilities (ductbanks, wall, floor or ceiling) shall be permitted.
- D. Access to personnel and equipment hatches for underground facilities shall not be blocked. In case any structure is built over an equipment access hatch, adequate passageway shall be provided for entry of a heavy truck and clearance for the use of a crane to lower equipment from the truck into the hatch.
- E. In case any structure is built adjacent to WMATA at-grade facilities (traction power substations, tiebreaker stations, train control or communications rooms) passageways for heavy trucks and adequate clearance shall be provided for the use of cranes to move equipment from trucks into and out of the equipment hatches and facilities.
- F. Emergency access gates for at-grade or aerial sections of WMATA roadway shall not be blocked. Adequate passage from the gates to public streets shall be provided.
- G. As-Built documentation shall refer to Section 1.7.

### **3.27 Energized Roadway / WMATA Right-of-Way Fencing**

- A. WMATA maintains high standards for right-of-way fencing securing the high voltage operating railroad and other energized facilities.

- B.** Modifications to WMATA fencing must meet the design standards whether modifications are temporary or permanent.
- C.** Fence modifications must be reviewed, approved and coordinated with WMATA. The ODC must clearly delineate operating stationing where fencing is to be modified. WMATA will evaluate whether there is impact to existing Intrusion Detection Warning Systems.

### **3.28 Grounding and Bonding - WMATA Structures**

- A.** Grounding of WMATA fencing, personnel safety, service equipment, facilities, etc. will be as per WMATA Specifications.
- B.** Bonding for stray current and cathodic protection will be as per WMATA Specifications.
- C.** Ground Connections - WMATA requires exothermic process in accordance with ANSI / EEE80-2000 (exothermic is defined as the use of powdered metals contained in a mold to form a molecular bond between materials to be connected without application of an external source of heat or power).

### **3.29 Lighting Standards - Impacting WMATA Structures/Property**

- A.** For proposed temporary and/or permanent modifications lighting criteria shall be as per WMATA's Design Criteria for all construction.
- B.** WMATA lighting criteria were developed as an integral part of the architectural concept, with the purpose of providing comfort, safety and accessibility to patrons, as well as lighting system reliability and efficiency. Lighting design and installation must be closely coordinated with the following:
  - 1.** Safety and security requirements.
  - 2.** ADA Regulation.
  - 3.** CCTV systems.
  - 4.** Maintenance Factors.
  - 5.** Landscaping.
- C.** Temporary lighting modifications shall be maintained by the developer/contractor.
- D.** Requirements for temporary and permanent lighting modifications impacting WMATA structures and/or property will be conveyed in WMATA design reviews and through a real estate entry permit.
- E.** Impact on any WMATA emergency lighting is to be as per WMATA's Design Criteria for all construction.

### **3.30 Corrosion Protection**

- A.** Stray Current Protection. The ODC must be aware that, since WMATA transit cars are powered by direct current (750 volts DC) electricity, direct current can enter the earth through unintentional leakage from WMATA's negative ground return system. The leakage or stray current may flow to and discharge from underground metallic elements (i.e. steel reinforcing, pipelines, ground systems, etc.) that are in contact with any electrolyte, including earth, in the vicinity of WMATA's facilities and systems. Because stray current may be corrosive to metal at locations where it flows into an electrolyte, the ODC is further cautioned to investigate the site for stray current and to provide the means for stray current mitigation when needed. This may include bonding all adjacent structures subject to corrosion in close proximity to WMATA's energized roadway.
- B.** Further information concerning stray current mitigation can be obtained by contacting The National Association of Corrosion Engineers (NACE), P.O. Box 218340 Houston, Texas 77812 (281-228-6200) or website located at [www.nace.org](http://www.nace.org).
- C.** Casing, pipe, tunnel, sleeve or similar structure(s) that will be subject to corrosion, when installed under any WMATA facility, structure, or at-grade roadway, will require corrosion protection. The proposed corrosion protection design scheme should be submitted to WMATA for approval and specifically identified/highlighted as proposed corrosion protection measures.
- D.** Underground casing, pipe, tunnel, sleeve or similar structure(s) that will be subject to corrosion, when installed on the sides adjacent to any WMATA structure, may require corrosion protection. Coordinate with WMATA the necessity of such structure, and if it is required the proposed corrosion protection design scheme should be submitted to WMATA for approval.

### **3.31 Certification of Design, Installation, and Monitoring**

The ODC will provide written certification that designs, installations, and monitoring are completed and implemented per approved drawings and plans.

### **3.32 WMATA Vent Shaft Protection**

- A.** Where demolition or construction will take place in close proximity to a WMATA vent shaft, the vent shaft shall be protected with a wooden structure constructed of fire retardant materials. The protection design must be approved by WMATA. Reference [Appendix 3](#), Plate L-1.
- B.** When WMATA vent shafts are located in a sidewalk adjacent to the construction site and are located within the 'protected walkway', the vent shafts may be covered with an expanded metal screen to provide a better walking surface when pedestrian traffic is forced by the curb and the construction fence to walk across the vent grate. The construction fence adjacent to the vent shaft shall be walled with exterior plywood for the entire length of the vent plus four feet extra at each end and laterally braced for wind loads.

- C. Expanded metal screen shall not be used to cover a grate where it will restrict the opening for an intake or an exhaust fan.

### **3.33 WMATA Escalator Overhead Protection**

Where demolition or construction will take place over a WMATA escalator, protection must be installed. The protection design must be submitted and approved by WMATA. Reference [Appendix 3](#), Plate E-1 and E-2.

This page intentionally blank.

## Section 4 - Monitoring, Instrumentation and Contingency Plans

### 4.1 General

- A. The ODC is required to design, submit for approval, and implement a monitoring program.
- B. Selection, design, installation, reading, and documentation of the monitoring program are to be conducted by a licensed Land Surveyor or a Professional Engineer registered in the jurisdiction of the proposed project. All monitoring data and reports requiring optical surveying submitted to WMATA must be signed, sealed and certified by a licensed Land Surveyor or a Professional Engineer registered in the jurisdiction of the proposed project. It is the responsibility of the ODC to document and convey compliance of their proposed monitoring system with WMATA's minimal requirements.
- C. Instrumentation and monitoring of WMATA structures, utilities and track are required to ensure that structural or functional inadequacy does not develop as a result of the proposed adjacent construction. Monitoring is done by measurement of displacement, deformation, strain, stress, crack width, joint separation, water leaks, and observation of the formation of new cracks, etc. In addition, monitoring will be required to ensure the adjacent construction support of excavation system is functioning as designed and the loads on WMATA structures remain within design limits. If changes are observed, the frequency of monitoring will be increased. If the changes exceed the established threshold limits, the ODC will implement contingency measures.
- D. The ODC will be required to develop a written plan for procedures to ascertain structural condition(s) of WMATA facilities and proposed procedures for monitoring potential movement; these procedures shall be submitted and approved prior to entry onto WMATA property. The plan will contain contingency measures listing the immediate remedial action to be taken in the event movement reaches the established threshold limits and/or damage is observed. The contingency monitoring plan for each adjacent construction project will be evaluated for acceptable threshold limits for WMATA structures or facilities.
- E. All instrumentation, monitoring work, documentation, monitoring reports, and any contingency measures required as a result of the adjacent construction shall be the sole responsibility of the ODC for the adjacent construction project.

### 4.2 Monitoring Stages

- A. **Stage 1 - Initial Pre-Construction Monitoring:** Stage 1 requires a survey of conditions within the WMATA structure or facility and obtaining initial readings at established monitoring points.

The first stages of monitoring shall be done before construction and excavation begins in WMATA's ZOI. However, monitoring phases of soldier beams, top supports and heel blocks shall be completed immediately after installation. The

initial readings shall be based on an average of two (2) sets of initial readings, taken at least 30 days in advance of the adjacent construction work. However, the ODC is encouraged to obtain more than two (2) sets of pre-construction data.

The ODC will provide the preconstruction survey, a summary report, and photographs of findings for WMATA review and record.

- B. Stage 2 - Project Monitoring during Construction:** Stage 2 includes monitoring during demolition, excavation and construction and will be done at WMATA-approved frequency intervals, normally every week. The monitoring frequency will be increased as necessary during critical construction activities such as blasting or tunneling.

The ODC may request, in writing, to suspend monitoring when the slab-at-grade level or the first slab above grade is placed and concrete has acquired at least 85% design strength along with backfill zones completed to grade level. The request must show a minimum of four (4) weeks consecutive reports showing no movement after these conditions are met. After WMATA has agreed movements have ceased and/or stabilized Stage 2 monitoring may be stopped.

Any request to remove the monitoring equipment will be evaluated on a project by project basis.

- C. Stage 3 - Post-Construction Monitoring:** Stage 3 includes final survey monitoring performed after substantial construction completion to determine changes to the alignment, document the post-construction condition, and provide photographic records. In addition to structural monitoring, a final alignment survey of the rail/tracks will be required for comparison with the initial survey data.

The ODC shall examine each property to determine/assess changes from original conditions as established by preconstruction inspection(s). These post-construction engineering assessments shall be furnished in a written report in addition to final monitoring data results.

The ODC shall also provide written remedial or corrective measures to be taken should any deviations and/or damage occur as a result of the adjacent construction project and/or monitoring phases.

#### 4.3 Monitoring Plan

- A.** The monitoring plan for the WMATA facility should be coordinated with the overall project design. Project design plans should be reviewed and approved by WMATA prior to submission of a structural monitoring plan. The monitoring and contingency plans must be prepared and certified by a Professional Engineer or a licensed Land Surveyor registered in the jurisdiction of the proposed project. As a minimum, the plans are to include:
1. A key plan with north arrow illustrating WMATA track stationing, the limits of the structural monitoring program and monitoring locations.

2. Instrumentation details including accuracy, technical specification from manufacturer, survey field procedures, calibration requirements and certifications (see [Appendix 4](#) example). ODC is required to use the "Monitoring Plan Instrumentation Checklist" provided in [Appendix 4](#).
  3. Schedule of surveying / monitoring.
  4. Data reduction, presentation, and evaluation, and details of the monitoring report.
  5. Threshold / limiting values.
  6. Contingency Plan.
- B.** In order to detect movement of buildings or structures affected by construction, the ODC will, prior to excavation, establish a system of vertical and horizontal control points on or about potentially affected buildings or structures, tied to stable survey control points located beyond the ZOI, preferably in WMATA's design datum. WMATA has a network of survey control points which will be made available to the ODC upon request.
- C.** The ODC will employ Certified Survey Technicians to perform survey work in accordance with the FGCC "Standards and Specifications for Geodetic Control Networks" ([http://www.ngs.noaa.gov/FGCS/tech\\_pub/1984-stds-specs-geodetic-control-networks.htm](http://www.ngs.noaa.gov/FGCS/tech_pub/1984-stds-specs-geodetic-control-networks.htm)) using First Order, Class 1 specifications for horizontal movement detection and Second Order, Class 1 specifications for vertical movement detection, or other WMATA approved standards and procedures. All vertical movement detection requires precise or semi-precise single-piece rods used in conjunction with a digital level or automatic level of sufficient accuracy. A plan of the proposed system including survey equipment, survey procedures and markers will be submitted for approval. (See [Appendix 4](#))

#### **4.4 Instrumentation**

- A.** The extent of the instrumentation and monitoring will depend on the size and type of the WMATA facilities and the adjacent construction. A detailed instrumentation plan for the monitoring program will be prepared by the ODC for each structure potentially affected by the work. Instrumentation scope and selection will be based on the requirements of the specific project including groundwater levels and pressures, strut, tieback and anchor loads, anticipated horizontal and vertical movement of the WMATA facilities and the adjacent construction support of excavation elements, and the sensitivity of the soil or rock between the support of excavation system and WMATA facilities.
- B.** WMATA strongly encourages the ODC to use instrumentation solutions that include remote and automated monitoring systems that are capable of reporting and post processing monitoring data to a password protected web site that only



authorized users have access to. Please note, access to many areas of the system are restricted.

- C.** All proposed methods of instrumentation installation and operation will be in accordance with the recommendations of the instrument manufacturer, unless otherwise approved by WMATA.
- D.** Inspection, installation, reading, and removal of instrumentation within WMATA structures may require closure of adjacent tracks, de-energization of adjacent third rail, and flag protection. All such activities will be planned in a timely manner and coordinated with WMATA's assigned CIF/CE.
- E.** For monitoring programs not utilizing automated and remote monitoring, setup of instruments and surveying of points shall be from a single control point for all readings. In the event this is not possible, a procedure is to be established where a cross check is viable to reduce errors due to multiple setup of instruments.
- F.** The ODC is responsible for ensuring immediate replacement of damaged instruments. When possible, readings for the damaged instrument will be plotted continuously, without an offset at the time of damage. The time of damage and replacement must be documented on the plot and / or data reports.
- G.** Security and Safety: Instrumentation installed (affixed) in any WMATA facility (ies) shall accompany a small identification placard illustrating ownership information. The placard shall be securely and safely affixed to the instrumentation at eye level and labeled with ODC's name, phone number, WMATA project affiliation, adjacent construction project number, and WMATA contact person / phone number.

#### **4.5 Guidelines - Monitoring & Instrumentation Minimum Requirements**

- A.** The ODC is required to provide monitoring reports to WMATA.
- B.** The report of results of all instrumentation readings and movement detection surveys is to include:
  - 1.** WMATA adjacent construction project name and number.
  - 2.** Statement of who performed the work with contact information and a point of contact who WMATA may contact to discuss technical aspects of the report.
  - 3.** Last observation(s) date and time and date and time of next scheduled observation(s).
  - 4.** Observer(s).
  - 5.** Interpretive summary of monitoring findings relative to the current construction activities (e.g., excavation is 2 feet below the top level support) or significant events that affect the readings.

6. Other pertinent data including weather and temperature or other events that may affect the observation(s).
7. Drawing showing a plan view of instrument occupied station(s), survey instrument backsight(s), other survey control point(s) and monitoring point(s) locations.
8. Current readings.
9. Initial readings.
10. Total movement for each monitoring point computed by subtracting the current readings from the initial readings.
11. Graphical representation of reduced data plotted against approved baselines which may include time, initial readings or fixed features such as centerline of tracks/structures. Graphical arrows can also be used to show direction and magnitude of movement using exaggerated scales.
12. Summary of survey instrument and accuracy, survey and or geotechnical equipment description, and survey procedures.

**C.** The movement detection report will:

1. Identify all values in English units, except crack gauges and/or crack calipers which may be measured in millimeters.
2. Identify the applicable tunnel section and WMATA stationing (Inbound or Outbound / utility marker number, etc.).
3. Indicate the direction of movement (sign convention) for all monitoring points. For example, (+) = toward the excavation or away from WMATA's centerline of track. Graphical arrows can also be used to show direction and magnitude of movement.

**D.** Movement Detection Report Format

1. Provide field data and reduced data, summarized in tables, in Adobe Acrobat (PDF) format.
2. Provide data in Excel spreadsheet format when requested.
3. In general, the report should include 5 basic parts:
  - i. Part 1 - a cover sheet which contains project details as listed in Section 4.5.B.1-6; (sample shown in [Appendix 4](#))
  - ii. Part 2 - a project layout drawing as described in Section 4.5. B.7;

- iii. Part 3 - monitoring data in tabular or spreadsheet format as described in Section 4.5.B.8-10;
  - iv. Part 4 - monitoring data in graphical formats as described in Section 4.5.B.11;
  - v. Part 5 - summary of equipment and procedures as described in Section 4.5.B.12. (sample shown in [Appendix 4](#))
- 4.** Inclinator data will be provided in tabular form and in graphs showing cumulative total displacement vs. elevation in WMATA's design datum (see [Appendix 4](#)).
- E.** Report Schedule
- 1.** All data below Level 2 threshold values (see Section 4.8) will be provided in hard copy or in digital format no later than 3:00 P.M. on the day following the data collection date.
  - 2.** When the specified reporting date is interrupted by weekends or holidays, the due date will be increased by an equivalent period.
  - 3.** When Level 2 threshold values have been exceeded, reports will be submitted on the date of reading.
- F.** Report Certification: All reports submitted must be certified by the Engineer or Surveyor of Record providing assessment of readings and necessary action resultant from the readings based on the requirements of the approved monitoring plan.

#### **4.6 WMATA Administrative Requirements**

- A.** Entrance to WMATA property for inspection or monitoring will require a real estate permit issued by the WMATA Office of Real Estate and Station Planning (LAND), an approved SSWP and all ODC personnel must be in possession of a valid WMATA contractor ID badge.
- B.** ODC indemnification and insurance policies and certificates of insurance (including Railroad Protective Liability Insurance) must be submitted and approved by the WMATA Office of Risk Management (RISK) prior to entering WMATA property. The ODC must maintain current insurance policies certifications with WMATA.
- C.** Inspection and monitoring work inside WMATA facilities will require WMATA operational support. Work performed within the track bed will require a third-rail power outage. The support or outage request, indicating the desired dates for entry into WMATA facilities, must be submitted on a JDAC Support Request form (JSR) at least thirty (30) days in advance of the date requested.

D. JDAC Support Request Forms must be submitted to the WMATA CIF/CE at least thirty (30) days prior to the WMATA Operating Week of the requested date(s). The WMATA Operating Week begins Saturday morning at 0001 hours (12:01 AM). JDAC Support Request forms shall not be submitted until the ODC has obtained approval of a monitoring plan, approved SSWP and a fully executed real estate permit from WMATA LAND.

E. The ODC must comply with Section 1.6

F. All work within WMATA's roadway must be performed during nonrevenue hours or as approved in advance by WMATA. WMATA nonrevenue hours\* are currently:

00:30 A.M. - 04:30 A.M.	Monday through Friday
03:30 A.M. - 06:30 A.M.	Saturday and Sunday

**\* Nonrevenue hours are subject to change without notification. WMATA cannot guarantee that the ODC will be able to work within the times above. Work time available is scheduled through the General Orders Track Rights System (GOTRS) and specific schedules are evaluated on a project by project basis as well as operational needs. Operational emergencies and maintenance requirements may impact scheduled work in the General Orders Track Rights System.**

G. The ODC must maintain compliance with the Letter Agreement, permit and funding in place. Failure to do so will prevent ODC from obtaining track access and staff support from WMATA.

#### 4.7 Minimum Monitoring Requirements

A. The extent of the instrumentation and monitoring program will depend on the size and type of both, the adjacent construction project and the WMATA facility potentially affected, as well as the anticipated loads imposed on the WMATA structures. Instrumentation of the excavation support system for the new construction, the surrounding ground, and the WMATA facilities will normally be required.

B. Excavation support systems for the portion of the adjacent construction within the WMATA ZOI will be instrumented and monitored to:

1. Measure the movement and deflection of the sheeting/cofferdam wall, etc. by optical surveying or other WMATA approved means. The top of the sheeting/cofferdam wall or soldier beams, and the top level of support will be monitored for horizontal and vertical movement. The spacing of survey points at the top and at first support (Tier One) shall not be greater than 25 feet.
2. Monitor the horizontal and vertical movement of heel blocks where lateral support to the sheeting/cofferdam wall is provided by rakers.

3. Monitor movement of the ground between the WMATA facility and the support of excavation system by means of inclinometers, movement detection points, or other WMATA approved instruments.
4. Measure pre-load values and changes within struts, ground anchors, rakers, and other elements of the support system, by load cells or WMATA approved instruments, so the support system can be kept within the limits established in design.
5. Measure groundwater levels to ensure compatibility with support of excavation design(s).
6. In addition to the establishment of the initial baseline data, monitoring of support of excavation system shall be started after the wale and the lateral support system at the first support level from the top (Tier One) is installed.

**C. WMATA Structures**

1. Structures within the WMATA ZOI will be instrumented and monitored to measure horizontal and vertical movements.
2. Stress and strain monitoring of WMATA structures may be required for complex projects.
3. Monitoring of groundwater levels and pressures may be required and will be coordinated with WMATA.
4. Seismograph monitoring of peak particle velocities at WMATA facilities will be required whenever blasting is within 100 feet of the WMATA ZOI. Monitoring will be required for each blast.
5. Structural monitoring must extend a minimum of 75 feet beyond the limits of excavation or the depth of excavation plus 25 feet on each side (whichever is greater). The distance between monitoring sections shall be 25 feet.
6. A monitoring section will consist of four points located at crown, invert, and at spring line on each side of the tunnel - for tunnels and similar underground structures. Monitor horizontal and vertical movement by optical surveying or by other method approved by WMATA, such as tape extensometer. Provide a typical section of the monitoring points and identify the direction of movement relative to the location of construction.
7. Dome relief vaults, vent shafts, etc. shall be monitored with survey points at four corners of the top of the WMATA structures.
8. The condition of the WMATA structure located within the ZOI should be noted and monitored, including provision of a photographic record. Existing

cracks will be monitored for change in width and length extension, and the formation of new cracks. Crack and/or caliper gauges should be mounted on significant structural cracks prior to demolition, excavation or other construction activities. Crack and/or caliper gauges may be used for crack monitoring. The width of the existing crack at the monitoring location should be recorded. The ends of each monitored crack shall be clearly marked to determine the extent of crack prior to the start of construction.

9. The monitoring of conditions within the WMATA facility should normally be done on a weekly basis, and the readings provided in accordance with the plan.

**D. Tunnel Monitoring**

1. Monitor and record any movement of the WMATA tunnels by inside measurement, using a system of instrumentation, during the adjacent construction excavation and initial construction. Submit data as stipulated on a case-by-case basis. The monitoring of tunnel movements shall be done at 25 foot intervals. The extent of monitoring shall start 75 feet before and finish 75 feet after/beyond the limits of excavation and construction affecting the WMATA tunnel or tunnels. For a bored flexible tunnel the data should include the three point convergence readings and the lateral movement of the tunnel. For a cut and cover box section and bored rigid tunnel, the horizontal and vertical movements of four points (one each in the side walls, one at the roof slab and one on the invert) should be monitored (see Plate B-1). In case of floating slabs in the tunnels an alternate point for monitoring shall be determined and coordinated with WMATA.
2. Survey the tunnels from the inside and note all the existing open cracks. Install crack gauges on the cracks, with epoxy, or use caliper methods to monitor. Existing crack widths at crack gauge locations shall be recorded, photographed and submitted to WMATA prior to demolition, excavation, or any other construction activities.
3. A system of monitoring any vertical **and** horizontal movement of the excavation support structure must be submitted for approval prior to construction. The submitted information is also to include a sample chart and methods of data collection.
4. Installation of inclinometers at suitable locations is recommended between the tunnels and the adjacent excavation. Follow the manufacturer's recommendations for installation locations of inclinometers relative to adjacent structures.
5. Prior to commencing construction, the WMATA tunnel structure shall be surveyed. The survey shall include vertical and horizontal alignment data.

6. Right-of-way entry requests, track rights requests, Roadway Worker Protection safety training, operational support and Site Specific Work Plans for WMATA structural monitoring program(s) must be in accordance with the requirements in this Manual.
7. Use of any WMATA land or right-of-way will require a real estate permit. The WMATA LAND will establish the fair market value or fee for the use or temporary lease of WMATA property.

#### **4.8 Monitoring Threshold or Limiting Values**

- A. Level 1 requires increasing the monitoring frequency. Level 1 values serve as an alert that change (displacement, crack widening, etc.) is occurring.
- B. Level 2 requires remedial action. When Level 2 values are reached, the developer/contractor will stop work in the WMATA ZOI, and any other work considered causing excessive movement.
- C. Table 4-1 are suggested threshold values to be used for monitoring and implementation of contingency measures and are provided as a guide in assisting the developer/contractor in preparing job-specific structural monitoring tolerances:

**Table 4-1 Limiting Values**

	Level 1 (Threshold Limit Values)	Level 2 (Remedial Action Limit Values)
Track/Rail (Horizontal and Vertical)	0.0625" (1/16") in any 25' length, but not to exceed a total of 0.25" from the existing location.	0.125" (1/8") in any 25' length, but not to exceed a total of 0.50" from the existing location.
Station and Tunnel (Horizontal and Vertical)	0.125" (1/8") in any 25' length, but not to exceed a total of 0.25" from the existing location. Movement includes displacement, deformation and rotation of the tunnel.	0.125" (1/8") in any 25' length, but not to exceed a total of 0.50" from the existing location. Movement includes displacement, deformation and rotation of the tunnel.
Other structures (Horizontal and Vertical)	0.25" (unless otherwise noted)	0.5" (unless otherwise noted)
Change in Crack Width	0.02" (0.5 mm)	0.04" (1.0 mm)
Pier supporting Aerial Structure	0.125" Horizontal and Vertical	0.25" Horizontal and Vertical
Support of Excavation	0.50" (at top)	0.75" (at top)
Soldier beam	0.25" (at top bracing)*	0.50" (at top bracing)*
Support of Excavation	0.25" (at top between supports)	0.5" (at top between supports)
Slurry Wall	0.125" (at top bracing)*	0.375" (at top bracing)*
Support of Excavation Heel-block	0.125" ❖	0.25" ❖
Blast Vibration at WMATA Structure	Not applicable	2.0 inches per second (Peak Particle Velocity)
Shaft/Dome Relief Vault (Horizontal and Vertical)	0.125" (1/8") in any 25' length along shaft, but not to exceed a total of 0.25" from the existing location.	0.125" (1/8") in any 25' length along shaft, but not to exceed a total of 0.5" from the existing location.

**Key**

- \* Displacement after bracing pre-loading.
- ❖ Horizontal displacement after pre-loading.



## **4.9 Contingency Plan**

- A.** The need for implementing a contingency plan will be established by WMATA on a case-by-case basis. A contingency plan will be required for all major projects adjacent to an underground tunnel. Prior to commencing construction, the ODC shall submit a contingency plan with the details of the corrective action to be taken in case of an emergency involving the following:
- 1.** Ground or structure movement exceeding the limits or threshold values.
  - 2.** Cracking of concrete structures.
  - 3.** Excessive opening of joints, movement and translation of joints in tunnel liners.
- B.** Settlement or horizontal movement of WMATA tunnels resulting from adjacent construction activity, or ring deformations in bored tunnels, shall not deviate from the pre-construction survey by more than the criteria specified in Table 4-1.
- C.** The corrective actions/measures necessary or the repairs necessary to WMATA structures due to the adjacent construction including excavation shall be the responsibility of the ODC.
- D.** Approval of the support of excavation system will be given when the monitoring and contingency plans have been reviewed and approved by WMATA.
- E.** Measures for Level 1 (Limit Values) - When the monitoring data reach or exceed Level 1 values, WMATA will be notified within 24 hours. The ODC will increase the frequency of monitoring to ascertain if a trend exists, as required by WMATA.
- F.** Measures for Level 2 (Remedial Action) - When the monitoring data reach or exceed Level 2 values, the ODC will immediately notify WMATA, stop all construction activities and implement the approved contingency measures. When the readings have stabilized, construction work may be resumed with the approval of WMATA.
- G.** Examples of contingency measures to protect WMATA structures from deformation or change in condition are:
- 1.** Maintaining an adequate supply of structural steel at the job site to enable bracing of the support of excavation system at additional points and /or levels.

2. Maintaining equipment on-site for compensation or compaction grouting to stop movement and stabilize the WMATA structure or track.
3. Backfill as necessary.

#### **4.10 ODC Monitoring Responsibilities**

- A.** The ODC has sole responsibility for providing monitoring until WMATA agrees in writing that monitoring may be terminated. The ODC is responsible for:
1. Requesting necessary site access to all monitoring instrumentation.
  2. Furnishing, installing, protecting and maintaining all equipment required for monitoring, including readout devices.
  3. Collection, interpretation and storing the monitoring data obtained. In addition to the requirements specified herein, the ODC is responsible during the course of the work to install, monitor and interpret additional instrumentation deemed necessary to ensure the safety of the public.
  4. Certification and prompt submission of all monitoring data to WMATA.
  5. Promptly responding to threshold values specified herein or as approved by WMATA and implementing agreed upon changes to construction.
  6. When requested, providing safe access for WMATA representatives to all instrument locations. Safe access will include stopping work activities, temporary relocation of obstructing materials and equipment, provision of ladders, working platforms and hoisting services, and any other needs in the opinion of WMATA representatives are necessary to ensure safety. Furnish safety equipment including respirators and harnesses for use by WMATA representatives during site visits.
  7. Restoration of areas affected by the monitoring program to the satisfaction of WMATA at completion of the work.
  8. Monitoring targets should be installed using epoxy or other methods. Disruption of substrate mounting surface is prohibited. Installation of monitoring targets in public areas and surfaces with architectural treatment must be specifically approved by WMATA.

This page intentionally blank.

## Section 5 - Safety, Operational Requirements and Compliance

### 5.1 General

- A. Each ODC should review: 1) WMATA's Construction Safety and Environmental Manual and 2) Metrorail Safety Rules and Procedures Handbook prior to contemplating any work on or adjacent WMATA. Each manual is available upon request from the project CE. The prevention of accidents in the course of completing any joint development or adjacent construction project is of primary importance to everyone connected to WMATA. WMATA is an organization totally committed to safety - safety in construction and operations. It is the Authority's responsibility to the general public to assure them of an organization which is not only innovative but also effectively implementing the highest safety standards.
- B. The ODC shall request and conduct a pre-construction field meeting with WMATA's Construction Inspection Facilitator prior to scheduling any work in WMATA's ZOI (work adjacent to, over, or on WMATA property, or which could potentially endanger, impact, or impair the Authority's revenue operations or facilities). These meetings are typically held on site and notification of such a meeting request must be scheduled a minimum of ten (10) work days in advance.

### 5.2 Safety, Construction, and WMATA Operational Considerations

- A. The ODC must initiate and complete the administrative forms included with [Appendix 5](#) when WMATA operational support functions and/or electrical power outage(s) are required. The administrative forms shall be submitted to WMATA for processing in WMATA's GOTRS. Appropriate administrative requests / forms for WMATA operational support for wayside work (non-power outage) and/or a scheduled power outage must be submitted to the WMATA CE at least thirty (35) days prior to the WMATA Operating Week of the requested date(s). The WMATA Operating Week begins Saturday morning at 0001 hours (12:01 AM). The thirty (35) day advance notification is necessary to allow WMATA sufficient notice to schedule personnel and/or support equipment, and to adjust WMATA operations and maintenance to accommodate the developer's/contractor's request wherever possible.

A Site Specific Work Plan (SSWP) must be submitted a minimum of 60 days prior to desired start of work date. No track access will be permitted without approved access and SSWP.

- B. ODC personnel are bound by WMATA's Safety Rules and Procedures while on or within WMATA's Roadway and/or air space.

- C.** The ODC is required to submit a detailed construction sequence and equipment staging plan for all work that will impact WMATA interests. This plan shall include necessary Maintenance of Traffic plans or similar plans required by local agencies. The ODC shall maintain both vehicular and pedestrian traffic, and existing streets and sidewalks within and adjacent to the project site at all times during the duration of the project.
- D.** Construction Safety, Fire Signage and Traffic Control Devices on WMATA property (for pedestrian and/or vehicular traffic)
- 1.** The ODC shall maintain traffic and erect and maintain traffic control devices, as required by approved plans.
  - 2.** Safety signage and markers are to be included as part of the construction sequence and staging plans submitted to WMATA for review and approval.
  - 3.** Safety signage and markers are to be fabricated in accordance with the codes and regulations of the local jurisdictional authorities where the project is proposed.
  - 4.** ODC shall install and maintain any temporary safety signage and/or markers placed on WMATA property during construction.
  - 5.** Access shall be maintained to fire hydrants, stand pipe/siamese connections and fire alarm boxes. Free access must be given to each fire hydrant, stand pipe/siamese connections, and fire alarm boxes as approved by local jurisdictional fire departments and WMATA whenever work is being carried on. Obstructions shall not be piled at any time or placed within 10 feet of any fire hydrant, stand pipe/siamese connection, or fire alarm box. The position/ location of hydrants, stand pipes/siamese connections, and/or fire alarm boxes must be indicated by suitable signage and lights that are readily seen and accessible in both day and night when materials are placed in the vicinity of fire equipment (as approved by the local Fire Marshal in the jurisdiction of the proposed project).
  - 6.** The ODC shall erect and maintain signs, fences, barricades, lighting and pedestrian bridges and provide watchmen for the protection of public travel, the work site, adjoining WMATA property and adjoining public places.
  - 7.** The ODC, in complying with OSHA standards on WMATA property, shall barricade all work area(s) or close excavations and openings in floors, walls and other parts of structures while openings are not protected full time. Barricades shall be substantial in character, neat in appearance,

constructed of approved materials and of approved size. See also, Section 5.4.D and 5.4.E.

8. ODC's are to take approved positive measures on WMATA property to prevent unauthorized entry into the construction site of the work and storage areas. Protective devices shall be in accordance with codes and regulations of jurisdictional agencies.

### 5.3 Operational Requirements

- A. WMATA's fire escape routes shall not be obstructed. Metrorail Emergency Response Maps will be used to determine if the proposed development and/or the related construction activities will have a potential impact to existing WMATA emergency routes and local fire department access route(s).
- B. Projects that require working over or adjacent to WMATA station entrances shall develop their construction procedures and sequences of work to meet the following minimum requirements:
  1. Construction operations on or directly adjacent WMATA facilities must be planned, scheduled and carried out in a way that will afford WMATA customers (and the general public) a clean, safe and orderly access to and from the station entrance during revenue hours.
  2. Construction activities that involve swinging a crane and suspended loads over pedestrian areas, WMATA station entrances and escalators, Roadway and WMATA passenger areas shall not be performed during revenue hours \*, but must be performed during the non-revenue hours of 00:30 AM to 04:30 AM on weekdays; 03:30 AM to 06:30 AM on Saturdays and Sundays.

**\* Nonrevenue hours are subject to change without notification. WMATA cannot guarantee that the ODC will be able to work within the times above. Work time available is scheduled through the General Orders Track Rights System (GOTRS) and specific schedules are evaluated on a project by project basis as well as operational needs. Operational emergencies and maintenance requirements may impact scheduled work in the General Orders Track Rights System.**

### 5.4 Overhead Protection

- A. Overhead Protection - Station Entrances and Public Areas. Overhead protection shall be provided whenever there is a possibility of overhead fall hazards from construction material, personnel, dunnage, etc. Overhead protection is required on or around WMATA station entrances, WMATA bus stops, WMATA roadway,

WMATA elevators, and areas designated for public access to WMATA facilities. Erection/ installation of the overhead protection or shield for these areas will be executed during WMATA's non-revenue hours \*:

00:30 AM to 04:30 AM on weekdays

03:30 AM to 06:30 AM on Saturdays and Sundays

**\* Nonrevenue hours are subject to change without notification. WMATA cannot guarantee that the ODC will be able to work within the times above. Work time available is scheduled through the General Orders Track Rights System (GOTRS) and specific schedules are evaluated on a project by project basis as well as operational needs. Operational emergencies and maintenance requirements may impact scheduled work in the General Orders Track Rights System.**

**B.** Structural design criteria:

1. The design live load for all shields shall be 150 pounds per square foot minimum. The design wind load on the temporary structures shall be 20 pounds per square foot, on both the windward and leeward sides of the structure a total of 40 pounds per square foot in any one direction. The roof of the shield shall also be designed for an uplift pressure of 25 pounds per square foot (due to wind).
2. The shield(s) must be constructed of fire retardant materials. Materials and equipment shall not be stored on the completed shield. The roof of the shield shall be constructed and maintained watertight.

**C.** Lighting design / criteria:

1. Lighting in public areas and around affected WMATA facilities must be provided under the temporary shield(s) to maintain a minimum illumination level of ten (10) foot-candles at the escalator treads or at walking surfaces. The temporary lighting is to be maintained and power source provided by the developer / contractor during all construction phase(s). ODC shall demonstrate in the field to WMATA that required illumination levels are being maintained throughout construction.
2. Temporary disruption in WMATA's existing electrical systems (lighting) will require temporary lighting and maintenance of the current standard illumination levels. Electrical staging plans are required for WMATA review and approval. WMATA's design criteria for facility lighting is identified in the Manual of Design Criteria which is available upon request.

- D.** Construction barricades shall be provided around all temporary construction areas and WMATA property to prevent public access in accordance with OSHA standards. Temporary barricades / fencing must be a minimum of six (6) feet in height and secured and maintained to withstand wind loads and public vandalism. Use of wooden fences will require material with a minimum of (1) hour fire-rating.
- E.** An unrestricted public access path shall be provided at the upper landing of the entrance escalator way in accordance with the following:

  - 1.** Vertical clearance between the walking surface and the lowest projection of the shield shall be a minimum of seven (7) feet.
  - 2.** A clear pedestrian runoff area extending beyond the escalator newel shall be provided, the least dimension of which shall be twenty (20) feet.
  - 3.** A fifteen (15) foot wide strip (other than the sidewalk) shall be maintained on the side of the escalator for circulation when the escalator is pointed away from a street corner.
  - 4.** A clear direct path from any WMATA emergency exit to the public street shall be maintained at all times.
- F.** Temporary sidewalks or pedestrian ways which will be in use more than 10 days shall be constructed of four (4) inch thick Portland cement concrete or four inches of asphaltic concrete placed and suitably finished for pedestrian traffic. Temporary sidewalks are to be a minimum width of five (5) feet wide.
- G.** All modified or temporary pedestrian access paths shall be ADA compliant.

## **5.5 Overhead Protection - Operating Roadway**

- A.** A construction project that will require work over, under or adjacent to WMATA at grade or aerial segments, including machinery operation, construction of scaffolding or any other potentially hazardous adjacent work, shall be done during non-revenue hours with a "supervisory" power outage, or as otherwise approved by WMATA.
- B.** Work may be approved to be performed during revenue hours with conditions such as constructing a temporary protective shield to protect WMATA's operating Roadway and facilities in accordance with the above minimum design load and other requirements of this Manual. The shield shall have solid sides and both sides and deck shall be designed to withstand the air pressures generated by a moving train unless otherwise noted by WMATA's Manual of Structural Design Criteria.



The shield shall be constructed or installed with a WMATA power outage in the construction area during non-revenue hours. Reference [Appendix 5](#) for WMATA power outage requirements. The design and field installation for the protective shield must be certified in writing by a registered professional engineer practicing in the jurisdiction of the project and shall be approved by WMATA. The certification must be obtained prior to putting the shield in field use. A visual inspection is also required.

Once written certification is received, work may proceed above the shield during revenue hours. Crane(s) shall not swing over the shield. [Reinforcing steel may be tied, but not swung over the shield using a crane during revenue hours.]

- C.** Crane operators working in areas adjacent to WMATA facilities where encroachments are possible shall possess a current National Commission for The Certification of Crane Operators certification for the type of crane being operated.
- D.** Equipment used for sheeting and shoring operations shall be positioned and operated so that the equipment is precluded from overturning and falling onto or fouling WMATA roadway. Soldier piles must not be swung over the WMATA roadway during revenue hours. Auguring or pile driving equipment shall be oriented parallel to the roadway and in such a field set-up to prevent piles or equipment from falling or fouling WMATA roadway.
- E.** Construction cranes shall not swing over the operating roadway during revenue operations. Crane certification and inspection documents shall be available for review by WMATA's Department of System Safety and Environmental Management (SAFE) and the Office of Risk Management (RISK) personnel at any time.
- F.** WMATA operational support will be required to monitor the Roadway for all auguring, pile driving or other work that can impact WMATA's operating system. The ODC shall make a formal request for any operational support by submitting a JDAC Support Request form to the CIF/CE. Costs associated with the support shall be borne by the ODC.
- G.** The ODC shall request access rights or track rights to perform work during WMATA's non-revenue hours of operation. The ODC shall make a formal request for access and support by submitting a JDAC Support Request form to the CE. Costs associated with the request shall be borne by the ODC.

## **5.6 Other WMATA Facilities**

- A.** Access from public streets to WMATA fan shafts, vent shafts and emergency exits shall be maintained at all times. WMATA shafts shall be protected from dust and debris. Reference [Appendix 3](#) for details.
- B.** Use hand excavation and/or approved alternative method in the vicinity of communication lines or WMATA, PEPCO, and Dominion Virginia Power lines feeding the Metro system.
- C.** Flammable liquids shall not be stored over, under, or within 25 feet horizontally of any WMATA facility. If installation by the project is required within 25 to 100 feet horizontally of the structure protective encasement of the tanks will be required. Existing underground tanks located within 100 feet horizontally of WMATA facilities and scheduled to be abandoned shall be removed and properly disposed. New underground tanks shall be designed to current applicable codes.

## **5.7 Modifications & Direct Connection to a WMATA Station / Facility**

- A.** Modifications To Structures
  - 1.** Design must allow for positive drainage around WMATA structures where impact or modifications are necessary.
  - 2.** Drawings and specifications illustrating the details of required changes shall be prepared by the ODC. Normally, to meet sidewalk grades, six or eight inches of the vent or shaft is removed, the existing steel is bent to accommodate the new steel and new angles are installed to hold the grate. The grates shall be reinstalled after the concrete has set. Grates are designed for AASHTO H-25 live loading.
  - 3.** The ODC will be required to increase the height of the affected WMATA facility or take preventive measures as required by WMATA if the adjacent construction (including modifications to existing grade elevations) would cause a change in hydrology (ponding of water, increase in water runoff adjacent to WMATA facilities, etc.).
  - 4.** A photometric study (site lighting plan with projected lighting illumination levels, wattage, etc.) will be required for temporary and / or permanent lighting modifications 'to' and 'around' existing WMATA facilities. The plans must be reviewed and approved prior to any field modifications beginning. The developer/contractor and WMATA personnel must coordinate and field verify illumination levels provided on the study plans prior to placing the

facility in service. ODC inspection of the temporary lighting will be regularly required to ensure that the approved illumination levels are maintained.

**B. Direct Connections**

- 1.** Connections to WMATA structures and/or facilities shall be designed, built and paid for by the ODC (or entity, person, etc.) requesting the connection in accordance with WMATA Policy Instruction 4.4/0 and Board Resolution (2011-31), or through a Direct Connection Agreement which usually, in addition to the fees associated with WMATA staff time, a connection fee will be charged. In certain cases, WMATA's Office of Real Estate and Station Planning may require documentation of such property requirements through a Maintenance and Operations Agreement. WMATA's Policy Instruction 4.4/0 and Board Resolution (2011-31) are available upon request.
- 2.** Underground passageways connecting to a WMATA facility (e.g. station, structure, passageway, etc.) must be sloped away from WMATA property in such a way as to provide positive drainage around WMATA facilities. The developer/contractor must design and install a drain system that is separate from WMATA's utilities in the event that the proposed passageway cannot be sloped away from the existing WMATA facility. The drain system design (to be reviewed and approved by WMATA) must preclude water from entering WMATA's facilities. Hydraulic pumps, if required, shall be sized to handle the fire sprinkler runoff, in the event of a fire.
- 3.** The connection shall have a bronze flexible roll-down gate installed between the two passageways. The gate shall be keyed on both sides with separate locks and a concealed manual pull chain for WMATA to open gate. Where the connection has 24-hour manned security on the non-WMATA side of the connection, glass doors may be used in lieu of a gate. If doors are used, each door shall be lockable from both sides.
- 4.** When required, a Closed-Circuit Television (CCTV) shall be installed at the ODC's expense and connected to the WMATA Kiosk. Power for the cameras shall be run from the CCTV to the Electrical Room servicing the Metrorail station. The existing conduit runs and spare breaker locations can be found in the WMATA "As Built" drawings. It is the ODC's responsibility to have the plans for this work prepared by a licensed professional engineer with expertise in this type of work. Intrusion alarms shall be installed on the gate or door and control wires installed between the gate or door and the communications room by the developer's

contractor. Final connection will be made by WMATA to the WMATA security system.

5. Finishes on the interior of the WMATA side of the connection shall be to WMATA's standards and specifications.
6. The power source for lighting and lights in the new passageway shall be run to the ODC's electrical facility and included in the development's emergency power panel. The Authority does not want any liability from electrical loss and/or maintenance.
7. Normally the Direct Connection tunnels are designed to be compatible with the building of which they are a part; however, in the event that a Direct Connection is to be maintained by WMATA, the design shall be in accordance with WMATA Design Criteria and construction will be required to meet WMATA's standard construction specifications.
8. Before removing the knock-out panel, the contractor shall have an approved dust protection system in place and fully functional. Typically, a dust protection system shall consist of a stationary partition that isolates the knock-out panel from the station. The dust partition shall be constructed using only fire rated materials. All joints shall be sealed with tape. The partition shall be constructed during non-revenue hours.
9. Adjacent construction with a connecting passageway(s) to WMATA facilities shall require special features to isolate one facility from the other for fire-safety as required by the local fire code, and may include automatic fire doors and dampers, sprinkler systems, smoke removal and ventilation systems and detection and alarm systems.
10. Specific operations and use agreements will typically be required when connecting with WMATA facilities.

## **5.8 Americans with Disabilities Act / WMATA Compliance Requirements**

WMATA's ADA General Guidelines - Comply with the rules and regulations found in 49 C.F.R Part 37 Transportation Services for Individuals with Disabilities, promulgated by the US Department of Transportation, and the ADA Accessibility Standards for Transportation Facilities Adopted by the FTA on 2006.

The Accessibility Standard for non-federally funded and non-transportation projects is: 2010 ADA Standards, issued by the Justice Department.

Connecting paths to Metro stations must also be reviewed and accepted by WMATA's Office of ADA Policy and Planning.

Parking structures and parking lots that are designed for the use of Metro customers must also comply with WMATA's more stringent standards and must be accepted by WMATA's Office of ADA Policy and Planning.

## **5.9 Demolition**

- A.** Demolition of structures adjacent to WMATA facilities by blasting, or by implosion of the structure by blasting shall not be allowed.
- B.** During piece-by-piece demolition, WMATA escalators shall be protected from dust generated by the demolition. The WMATA escalators shall be covered with polyethylene sheets during demolition to prevent dust from entering the escalator bearings. Demolition adjacent to a WMATA station entrance, that requires protection from dust, shall be done during non-revenue hours.
- C.** During demolition WMATA vents located adjacent to the site shall be protected with a vent cover. See [Appendix 3](#), Plate L-1.
- D.** The ODC must provide the complete demolition plan for WMATA review and approval. Based on the demolition plan and the nature of adjacent WMATA structure, WMATA may require the ODC to check the structural adequacy of the WMATA structure due to the effects of the impact of the demolition.

## **5.10 Safety & Security Certification Program Plan**

- A.** System safety and security play important roles in achieving and maintaining the Washington Metropolitan Area Transit Authority (WMATA) mission to provide exceptional service in a safe and secure operating environment. WMATA has implemented a Safety and Security Certification Program to help in the achievement of this mission.
- B.** The goal of safety and security certification is to ensure that Metrorail extensions, new and rehabilitated facilities and vehicles; and new and rehabilitated Metrobus facilities and equipment are operationally safe and secure for customers, employees, and the general public. To this end, the Safety and Security Certification Program verifies, through a formal process, that safety and security requirements are incorporated into design, construction/ installation, procurement, and testing activities; training programs; and operations and maintenance procedures.

- C.** ODC's will be required to participate in the program for those projects identified as requiring certification. The Safety & Security Certification Program Plan is available upon request.

This page intentionally blank.

## Section 6 - Real Estate and Insurance Requirements

### 6.1 Real Estate General Requirements

- A. Clearly depict impact to WMATA real property and/or easements on design plans submitted for WMATA review.
- B. Real estate transactions with WMATA are handled directly through the Office of Real Estate and Station Planning (LAND). The Office of Joint Development and Adjacent Construction (JDAC), for purposes of ODC's work, coordinates all design plans, engineering disciplines and real estate entry permit(s) for temporary and/or permanent real estate rights, leases, etc., with LAND.
- C. WMATA may grant permits, easements, licenses or other rights, on a case-by-case and first-come, first-served basis in response to third party requests to use or occupy WMATA real estate where it is determined that the proposed use will not adversely impact WMATA operations or existing or planned WMATA facilities.
- D. JDAC will review requests to use WMATA property (either temporary and/or permanent use) to determine the compatibility with existing or planned WMATA facilities. Review of requests will be coordinated by JDAC **after** design review phases are complete.
- E. WMATA/LAND is responsible for selecting the appropriate property interest that accommodates the requested use of WMATA property, for determining the fair market value for the real estate interest and for preparing the requisite documents.
- F. A completed WMATA real estate permit application is required for all temporary and permanent property interest requests that impact WMATA property. Impact is considered to include any property interest (including areas of tieback installations) and access by the ODC. WMATA requires payment of fair market value for any property interest used and requires payment of WMATA's costs associated with review of requests for permits, easements, licenses and other rights. Reference also Section No. 6.2.E for requirements for permanent impact to WMATA property. A real estate permit application and supportive documentation are required for:
  - 1. Property screening whereby temporary access on WMATA property is required.
  - 2. Providing operational support for structural monitoring of WMATA facilities.



3. Temporary access by construction personnel, equipment or devices for surveying and monitoring.
  4. Temporary support of excavation system on WMATA property (whether to be left in place or removed at the end of the project).
  5. Overhead protective structures that impact WMATA property.
  6. Placement of siltation devices and/or construction clearing and grading zones.
  7. New installations on WMATA property.
  8. New underground utilities within WMATA underground easements.
  9. New installations over WMATA facilities that encroach into WMATA air space and upper limits of surface and aerial easements.
  10. Encroachments into WMATA underground easements from underpinning structures and/or soil anchoring systems (such as tiebacks).
  11. Storm drainage runoff directed onto WMATA property from new construction.
  12. Encroachment onto any WMATA property including surface easements such as slope easements or access easements.
  13. Modification(s) to existing WMATA right-of-way fencing at surface levels.
- G.** The ODC shall plan and coordinate project design and construction on and adjacent to WMATA facilities/structures in advance of any property use considerations. WMATA design guidelines highlighted under Section No. 3 & 4 of this Manual may require structural monitoring of WMATA facilities, structures, etc. should construction impact WMATA's ZOI. Such impact and structural monitoring requirements typically necessitate the need for a WMATA real estate permit for purposes of gaining access onto WMATA property to design, survey, install, implement and/or execute monitoring programs.
- H.** Requests for new installations on WMATA property that will require WMATA to incur maintenance, security or other costs will normally be denied, unless the requesting party agrees to pay such costs and demonstrates the financial capability to pay such costs.

## 6.2 Procedures and Application Process

- A. Once the engineering design review phase has been completed by WMATA, and plans are approved or conditionally approved, the ODC is required to complete and submit the necessary real estate permit application and supporting documentation.
- B. The completed real estate permit application is submitted to WMATA. Click on the following link for additional information:  
  
[http://www.wmata.com/business/joint\\_development\\_opportunities/forms.cfm](http://www.wmata.com/business/joint_development_opportunities/forms.cfm)
- C. Provide the assigned CE a draft of the permit application for initial review prior to submission.
- D. WMATA will review all incoming requests on a first-come, first-served basis. Requests for use of real property will be coordinated with WMATA LAND.
- E. LAND, upon receipt of JDAC certification of the Permit Application will:
  - 1. Determine the required property interest.
  - 2. Establish the value of the property interest.
  - 3. Prepare and coordinate the requisite legal documents.
  - 4. Obtain WMATA Board of Directors and Federal Transit Administration approval when required.
  - 5. Issue, approve and sign the permit, easement, license, requisite legal documents, etc.
  - 6. Arrange to collect required compensation.
  - 7. LAND will coordinate with WMATA's Office of RISK to review and approve insurance policies and certificates of insurance in advance of delivery of the executed permit or conveyance document to applicant.
- F. Real estate requests that will permanently impact WMATA real property or easements (whether exclusive or non-exclusive easements) will generally require supportive documentation for property acquisition and/or conveyance. Reference [Appendix 6](#) for detailed WMATA criteria for property surveys and submission

documentation. Plan submissions for real property use shall include, at a minimum:

1. A certified plat of survey (and/or exhibit), prepared, signed and sealed by a licensed surveyor, suitable for recordation which clearly illustrates property interrelation to WMATA's property and facilities. The certified plat should represent a survey of the property being impacted and include all necessary units of measure for WMATA's real estate appraisal (e.g. proposed total areas, easement lengths, easement widths, upper and lower easement limits, etc.)
  2. Certified legal property description(s) of property or easements with metes and bounds, signed and sealed documentation by a licensed Land Surveyor practicing in the jurisdiction of the proposed project.
  3. Deed Book and Page Number of property/parcel identified on the plat and legal descriptions.
  4. Confirmation that survey is closed and tied to WMATA's existing control (limit of right-of-way to the property lines).
  5. Clarification of specific maintenance responsibilities and/or future access to such permanent at-grade or underground structures.
- G.** NOTE: Conveyances governed by the WMATA Board Regulation Concerning the Use by Others of WMATA Property, Joint Development Agreements and leases/permits which are specifically entered into for purpose of generating revenue for WMATA will be handled in accordance with the procedures established for those actions.

### **6.3 Real Estate Responsibility**

- A.** Documentation of impact to WMATA real property: The ODC shall plan, document, develop and coordinate real estate interests with WMATA.
- B.** The ODC shall coordinate permit requests with WMATA. It is preferred and less expensive for the ODC to coordinate all impact to WMATA's real property from joint and/or adjacent construction development in one (1) real estate entry permit application under one (1) applicant. This process requires advance planning and coordination on the part of the Developer/Contractor prior to interface with WMATA.

#### **6.4 Indemnification and General Insurance Requirements and Procedures**

- A.** The ODC will be responsible for complying with all applicable indemnification and insurance requirements for work activities impacting WMATA.
- B.** WMATA's indemnification and insurance requirements for joint development and adjacent construction are referenced in [Appendix 6](#) of this Manual. Any on-site work which could cause or with potential to cause impact to WMATA facilities or operations may not begin without proper insurances in place. Work will be suspended in the event insurance is not maintained current by the ODC. WMATA is to be named as an additional insured on all insurance relative to joint and adjacent construction work.
- C.** Insurance policies and certificates of insurance from the ODC are reviewed and processed by WMATA's Office of Risk Management (RISK) during permitting phases (along with LAND).
- D.** Copies of applicable insurance policies and certificates of insurance should be forwarded to WMATA as soon as the ODC is informed of the requisite insurance coverages for the project.
- E.** Contact may be made directly with WMATA's Office of Risk Management (202-962-1118) for any specific insurance issues/requirements/questions while working on, over, below or adjacent to WMATA facilities.

#### **6.5 Insurance Responsibility**

- A.** The ODC shall keep insurance policies and certificates of insurance current with WMATA during the full duration of each project.
- B.** All policies shall include a special cancellation provision which reads "The Authority is interested in the maintenance of this insurance, and it is agreed that this insurance will not be cancelled, materially changed or not renewed without at least thirty (30) days prior written notice to the Authority". Notice is by: (a) Certified Mail, Return Receipt Requested; (b) hand delivery; (c) a nationally recognized overnight courier service for next business day delivery; or (d) any telecommunications device capable of creating a written record of such notice and its receipt. Addressed to: Program Manager, Office of Real Estate and Station Planning, Washington Metropolitan Area Transit Authority, 600 Fifth Street, NW, Room 5B, Washington, DC 20001.

- C.** At least two (2) weeks prior to the expiration of the original policies or any renewals thereof, evidence of renewal or replacement policies of insurance, with the same terms and limits as expiring, shall be delivered to WMATA.

## **Section 7 - As-Built Documentation and Close Out**

### **7.1 As Built Documentation General Requirements**

- A.** During construction, the ODC shall maintain a record set of contract drawings annotated to illustrate changes incorporated as work progresses.
- B.** As-built drawings shall be prepared and provided by the ODC of the work for WMATA record. As-built records will be required for new facilities, structures, utilities, property rights related to WMATA structures and / or property resulting from the adjacent construction / joint development project. As-built drawings will include recordation of impacts within the WMATA ZOI.
- C.** Project as-built drawings must use WMATA's as-built drawings for the base layer, as applicable.
- D.** Drawings, plans, and calculations approved by WMATA and revised by the ODC must be resubmitted for approval.
- E.** The as-built documentation shall include, but not limited to, the following:
  - 1.** Depths of various elements of foundations in relation to survey data.
  - 2.** Horizontal and vertical locations of underground electrical and utility facilities.
  - 3.** Field changes of dimensions and details.
  - 4.** Changes accomplished by change orders.
  - 5.** Construction left in place, such as temporary support systems, and concrete left outside neat lines of permanent structures, including notes defining types and locations of items.
  - 6.** Any necessary Operations and Maintenance Manuals if WMATA is to maintain such facilities / equipment constructed by others.

### **7.2 As-Built Drawings**

- A.** Drafting shall be performed by skilled drafters using AutoCAD and shall match original contract drawings in line weights, symbols and lettering style and size.

- B.** ODC shall submit one set of as-built prints for review and approval using WMATA's As-built Documentation Format (Appendix 7) not later than two (2) weeks after final WMATA acceptance of the work.
- C.** Completed as-built drawings shall bear the signature of an officer of the ODC's organization, certifying compliance with as-built conditions, using a rubber stamp to the effect of:

<p><b>AS BUILT</b></p> <p>Date</p> <p>_____</p> <p>I certify that this drawing accurately depicts the work as constructed</p> <p>Signed - Officer of the Developer / Contractor</p> <p>Developer / Contractor's Printed Name and Company</p>
----------------------------------------------------------------------------------------------------------------------------------------------------------------------------------------------------------------------------------------------------

**7.3 As-built Drawing Submission Requirements**

- A.** Construction impact to WMATA easements shall be documented in as-built records. As-built records submitted to WMATA shall be formatted as follows:
  - 1.** Submit two (2) CDs with the individual drawing as-built files to WMATA in PDF (portable document format) and DWG (AutoCAD) formats in accordance with WMATA's current CADD Standards.
  - 2.** ODC shall update the WMATA electronic as-built files, where the ODC project has modified WMATA facilities, if applicable.
  - 3.** Submit one (1) hard copy of 1/2-size as-built documents to WMATA. These records are to be signed and certified by the engineer of record as "as-built".

#### **7.4 Closeout of Project**

- A.** The ODC is responsible for coordinating any required certifications with local jurisdictions and/or other agencies.
- B.** WMATA will verify that all punch list items are completed.
- C.** The ODC shall contact WMATA CE/CIF once all engineering / field support and interface functions are completed within the WMATA ZOI.
- D.** WMATA will issue a closeout letter to the ODC representing technical, fiscal, and administrative closeout of the project.



This page intentionally blank.

# Appendices

[Appendix 1 - General Procedures/Review Process](#)

[Appendix 2 - Not Used](#)

[Appendix 3 - Design Requirements and Considerations](#)

[Appendix 4 - Monitoring, Instrumentation and Considerations](#)

[Appendix 5 - Safety Requirements & Compliance](#)

[Appendix 6 - Real Estate, Insurance & Design Criteria Section 9 – Right-of-Way](#)

[Appendix 7 - As-Built Documentation & Closeout](#)

[Abbreviations](#)

[Glossary](#)

This page intentionally blank.

## Appendix 1 - General Procedures/ Review Process

### [WMATA Design & Coordination Checklist](#)

Click on the link to obtain the following documents:

[http://www.wmata.com/business/joint\\_development\\_opportunities/adjacent\\_construction\\_information.cfm](http://www.wmata.com/business/joint_development_opportunities/adjacent_construction_information.cfm)

- Adjacent Construction Project Flow Chart for Owner/Developer/Contractor (ODC)
- Consumer Authorization for Release of Personal Information
- Certification for Issuance of Metro SmarTrip Contractor Badge
- Document Request Form

This page intentionally blank.

## Typical WMATA Design & Coordination Checklist (for Applicant's Use)

PROJECT Control No. \_\_\_\_\_

### **Phase 1 - Application:**

- Project Number established for proposed project by WMATA (All documents shall reference project number.)
- Reviewed WMATA's Adjacent Construction Project Manual (ACPM)
- Reviewed WMATA's Safety Manual
- Submitted Document Request Form & Consumer Authorization for Release of Personal Information Form
- Received and reviewed any WMATA applicable reference material (as-builts, right-of-way plans, etc.)
- Agreement executed
- Payment of review and support fee

### **Phase 2 - Design / Drawings / Calculation Review:**

- Project Impact Statement completed
- Bus Impacts
- Sections showing foundations and WMATA structures
- Site Plan (detailing impact to WMATA, easements provided)
- Pertinent drawing/zone of influence diagram provided detailing level of impact on WMATA facilities
- Sheeting and shoring drawings
- Drainage area map(s) with calculations
- Architectural drawings
- Civil drawings
- Electrical drawings / photometric studies (as applicable)
- Structural drawings / calculations
- Column load tables
- Geotechnical report
- Finite element analysis
- All drawings / calculations signed and sealed
- Submit Real Estate Permit Application

### **Phase 3 - Pre-Construction Design Verification:**

- Structural monitoring and contingency plans
- Construction schedule / sequence plan identifying specific WMATA impact
- Construction layout of equipment relative to WMATA's right-of-way/roadway

- Equipment certifications for equipment working in WMATA's Zone of Influence
- Temporary safety plans and measures
- Structural monitoring and contingency plans
- Permanent easement / utility easement w/ plat and metes and bounds of prospective property

**Phase 4 - Pre-Construction Field Coordination & Verification:**

- Certification for Issuance of METRO SmarTrip Contractor Badge
- Safety training course required
- Site Specific Work Plan completed and submitted
- Submit JDAC Support Request Form
- JDAC Daily Support Tracking Form
- Right-of-entry and/or utility permit applied for / executed
- Indemnification /certification of insurance requirements
- Other local jurisdictional approvals/permits and forwarded
- Operational support arrangement(s)
- Locate any WMATA monumentation. Coordinate relocation/replacement with WMATA Survey Office.
- Utility location / identification and protection
- Pre-construction meeting with WMATA's Construction Inspection Facilitator
- WMATA field contact(s) information and communication chain established
- Pre-construction survey requirement met
- Boundary survey tie-in to WMATA coordinate system

**Phase 5 - Post Construction Coordination:**

- Post-construction survey requirement
- Punch List / Out-processing

**Phase 6 - Project Close Out:**

- As-Built requirement(s)
- Other requirement(s) provided \_\_\_\_\_

**NOTE:** This list is provided as a suggested reference for requirements which may be imposed on an Owner/Developer/Contractor in coordinating and developing their construction plans which may or may not impact WMATA facilities. Under no circumstance is there a guarantee that construction plans will expedited for review and approval. Planning, scheduling and coordination of the adjacent developer/contractors' project is at his/her sole expense and responsibility.

**Appendix 2 - Design Review Procedures**

**Not Used**



This page intentionally blank.

## Appendix 3 - Design Requirements and Considerations

### Plates

<a href="#">Plate A-1A:</a>	<a href="#">Soil Pressure Diagram for Two or More Levels of Support</a>
<a href="#">Plate A-1B:</a>	<a href="#">Soil Pressure Diagram for Cantilever and One Level of Support</a>
<a href="#">Plate A-2A,</a>	<a href="#">B, C, D &amp; E: Zone of Influence Diagrams</a>
<a href="#">Plate A-3A:</a>	<a href="#">Tunnel Underpinning Requirements (Case A)</a>
<a href="#">Plate A-3B:</a>	<a href="#">Tunnel Underpinning Requirements (Case B)</a>
<a href="#">Plate A-4:</a>	<a href="#">Distribution of Vertical Pressures</a>
<a href="#">Plate A-5A:</a>	<a href="#">Short Term Loading - Concrete Box Tunnel and other Cut &amp; Cover Structures</a>
<a href="#">Plate A-5B:</a>	<a href="#">Short term Loading- Bored Tunnel</a>
<a href="#">Plate A-6A:</a>	<a href="#">Traffic and Construction Equipment Loads</a>
<a href="#">Plate A-6B:</a>	<a href="#">Building or Construction Loads</a>
<a href="#">Plate A-7A:</a>	<a href="#">Long Term Loading Concrete Box Tunnel/Cut &amp; Cover Structures</a>
<a href="#">Plate A-7B:</a>	<a href="#">Long Term Loading Bored Tunnel</a>
<a href="#">Plate A-8A, B, C:</a>	<a href="#">Loading Condition- Running Tunnel in Rock &amp; Stations</a>
<a href="#">Plate A-8D &amp; E:</a>	<a href="#">Loading Condition - Stations</a>
<a href="#">Plate A-9:</a>	<a href="#">Rigid Support of Excavation System</a>
<a href="#">Plate L-1:</a>	<a href="#">Vent Cover</a>
<a href="#">Plate E-1:</a>	<a href="#">Overhead Protection – Escalators Toward Street</a>
<a href="#">Plate E-2:</a>	<a href="#">Overhead Protection – Escalators Away from Street</a>

### Tables

<a href="#">Table 3-1:</a>	<a href="#">AVERAGE VERTICAL LOAD ON ROCK TUNNELS</a>
<a href="#">Table 3-2:</a>	<a href="#">MODULUS OF SUBGRADE REACTION</a>
<a href="#">Table 3-3:</a>	<a href="#">Soil Properties for Design</a>
<a href="#">Table 3-4:</a>	<a href="#">Generalized Strata Descriptions</a>

### Specifications

[02820 Fencing](#)

### Drawings

[Fence Details](#)  
[At Grade Utility Markers](#)

This page intentionally blank.

**PLATE A-1A**

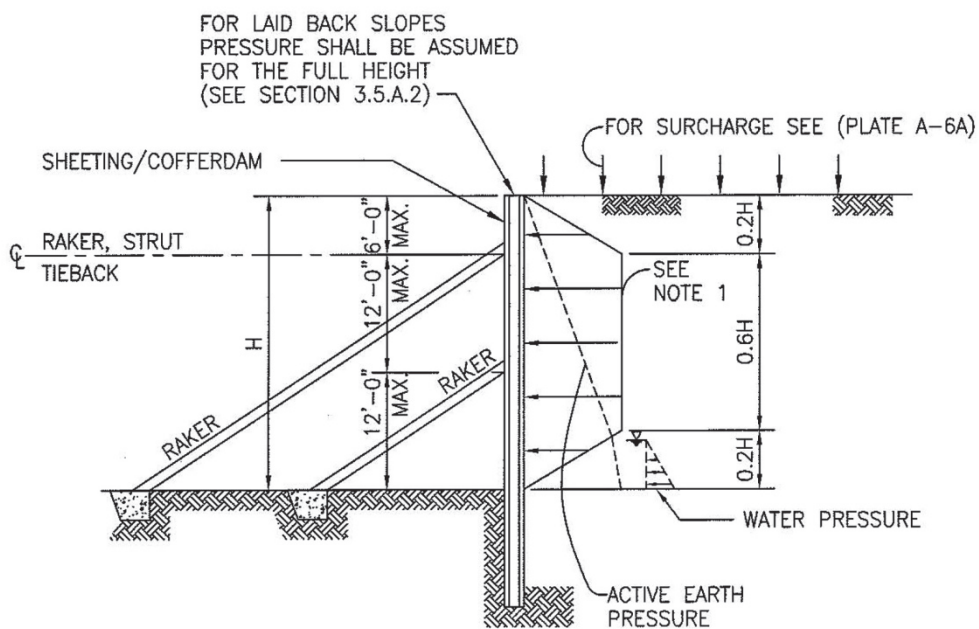

NOTES:

1. TRAPEZOIDAL PRESSURE DIAGRAM IS EQUAL TO THE AREA OF THE ACTIVE EARTH PRESSURE DIAGRAM TIMES A STIFFNESS FACTOR OF 1.25 TO 1.50. PER SECTION 3.6.A
2. SHEETING/COFFERDAM WALL CAN BE ASSUMED TO BE HINGED AT THE RAKER BRACE POINTS FOR SIMPLE ANALYSIS.
3. SHEETING/COFFERDAM WALL SHALL BE CHECKED FOR PARTIALLY EXCAVATED CONDITIONS.
4. THE WATER PRESSURE IS GENERALLY NOT INCLUDED FOR A LAGGED SOLDIER PILE WALL.
5. PRESSURE DIAGRAM IS ALSO FOR THE DESIGN OF WALERS, RAKERS, AND TIEBACKS.
6. SOLDIER PILE OR COFFERDAM WALL ABOVE TOP RESTRAINT SHALL BE DESIGNED AS A CANTILEVER
7. HEEL BLOCK DESIGN PER SECTION 3.7.M

**SOIL PRESSURE DIAGRAM**  
**FOR TWO OR MORE LEVEL SUPPORT OF EXCAVATION**

WMATA ENGINEERING STANDARDS

## PLATE A-1B

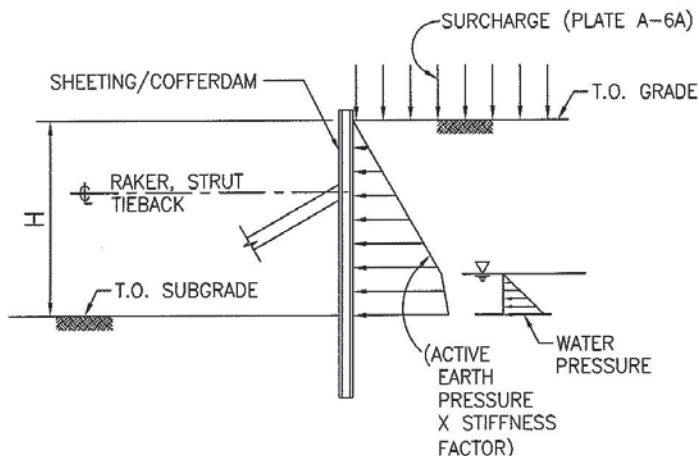

### NOTES:

1. STIFFNESS FACTOR OF 1.25 OR 1.50 SHALL BE USED PER SECTION 3.6.A
2. SHEETING/COFFERDAM WALL SHALL BE CHECKED FOR PARTIALLY EXCAVATED CONDITION.
3. THE WATER PRESSURE IS GENERALLY NOT INCLUDED FOR A LAGGED SOLDIER PILE WALL.
4. PRESSURE DIAGRAM IS ALSO FOR THE DESIGN OF WALERS, STRUTS, RAKERS, AND TIEBACKS, FOR ONE LEVEL OF SUPPORT FOR THE EXCAVATION SUPPORT SYSTEM.
5. THE MAXIMUM DEPTH OF CANTILEVER SUPPORT SYSTEM SHALL NOT EXCEED 7 FEET. FOR THE CANTILEVER SUPPORT SYSTEM THE EMBEDDED DEPTH OF THE TOE SHALL BE TAKEN AS 1.3XTHEORETICAL EMBEDDED DEPTH REQUIRED.
6. FOR LAID BACK SLOPES SEE SECTION 3.5.A.2.
7. ASSUMPTION OF A HINGE POINT, AT OR BELOW SUBGRADE, SHOULD NOT BE USED IN THIS CASE WHERE A SINGLE EXTERNAL SUPPORT IS USED, UNLESS OTHERWISE APPROVED BY WMATA.

### SOIL PRESSURE DIAGRAM FOR CANTILEVER AND FOR ONE LEVEL SUPPORT OF EXCAVATION

WMATA ENGINEERING STANDARDS

PLATE A-2A

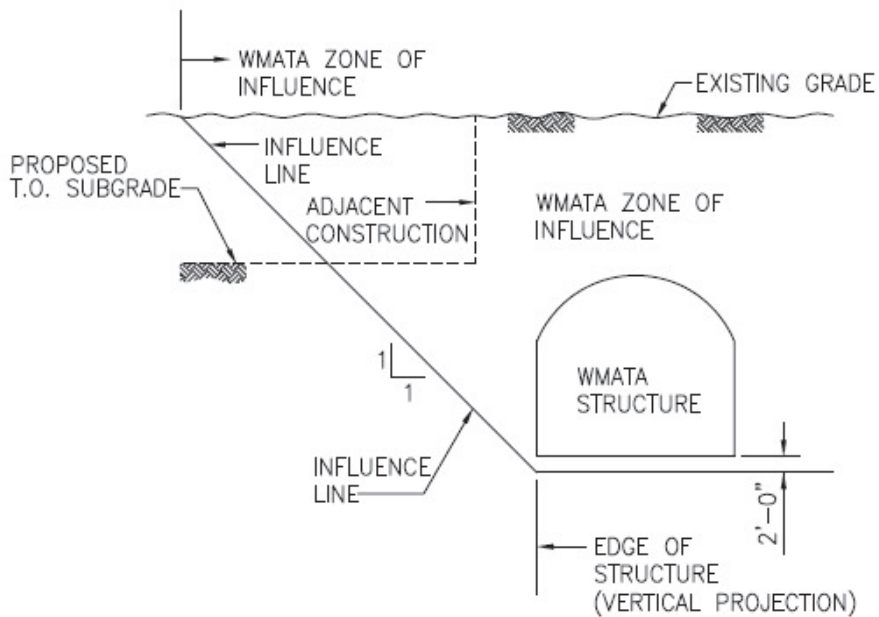

WMATA ZONE OF INFLUENCE  
(CASE A)

BELOW GRADE WMATA FACILITY AND  
WMATA FACILITY BELOW ADJACENT CONSTRUCTION

WMATA ENGINEERING STANDARDS

**PLATE A-2B**

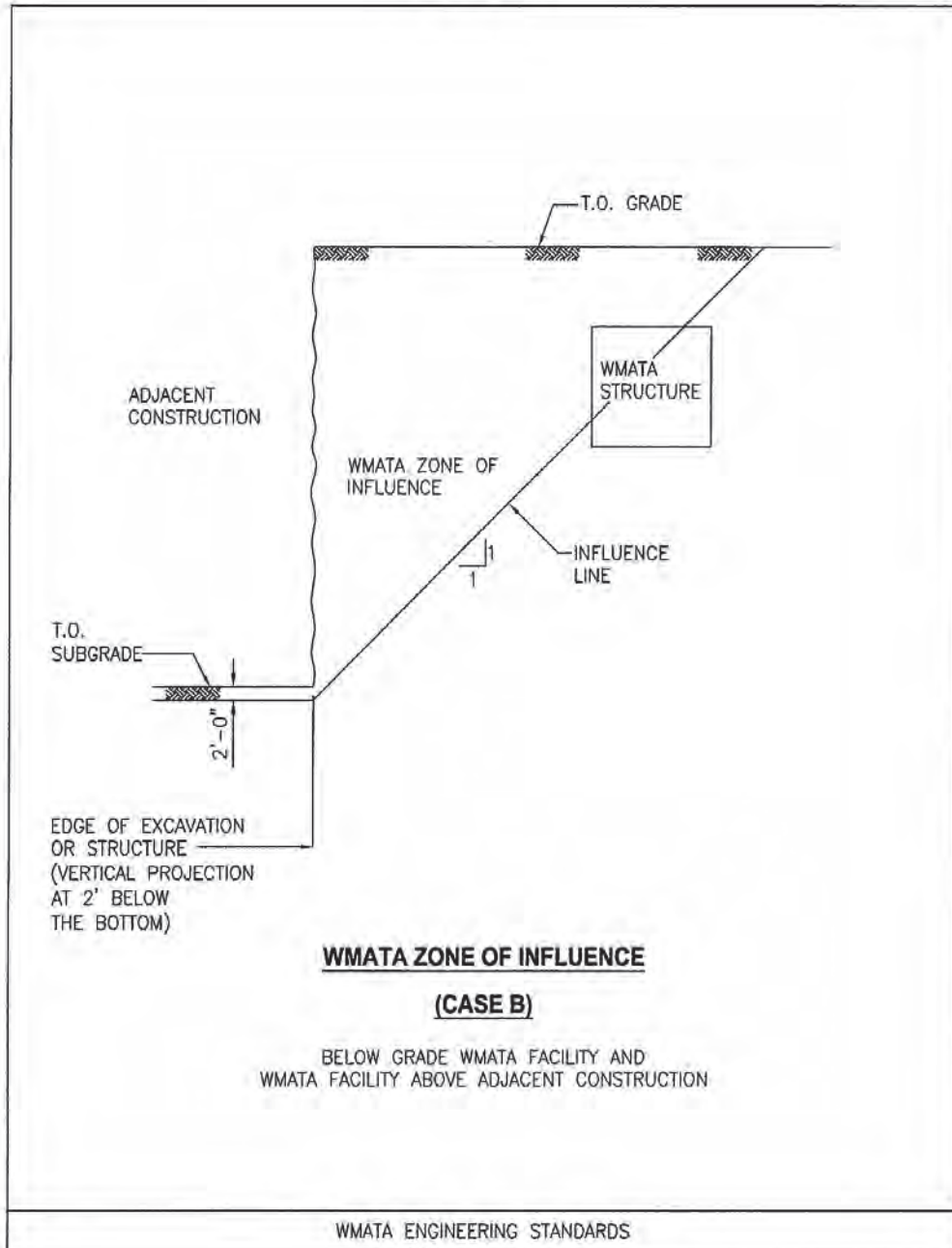

**PLATE A-2C**

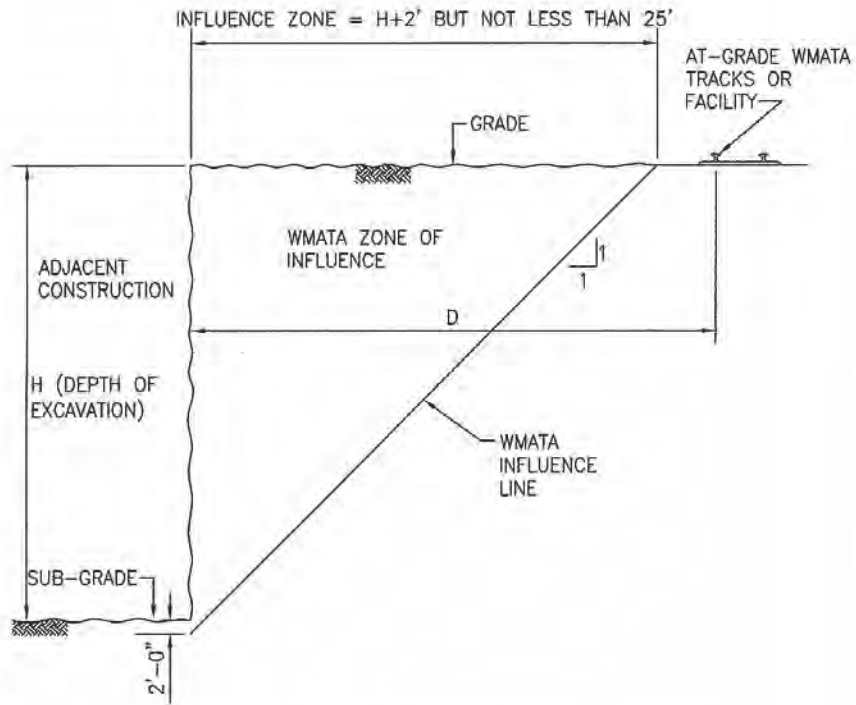

THE EXCAVATION WILL BE CONSIDERED TO BE IN THE WMATA ZONE OF INFLUENCE IF 'D' IS LESS THAN THE LARGER OF  $(H+2)$  FEET OR 25 FEET.

**WMATA ZONE OF INFLUENCE**

**(CASE C)**

ADJACENT CONSTRUCTION NEAR  
AT-GRADE WMATA TRACKS OR FACILITY

WMATA ENGINEERING STANDARDS

**APPENDIX -3**



**PLATE A-2D**

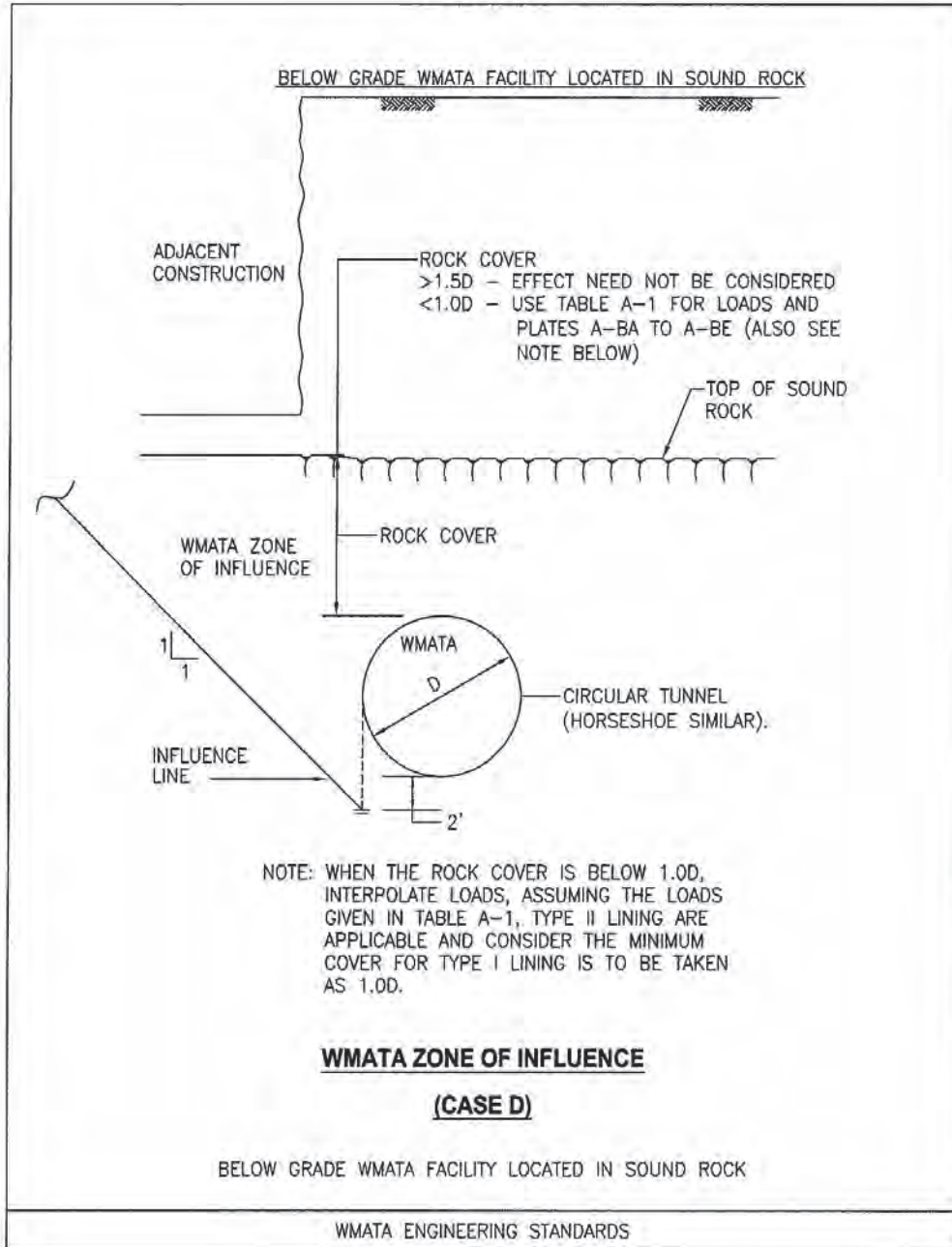

**PLATE A-2E**

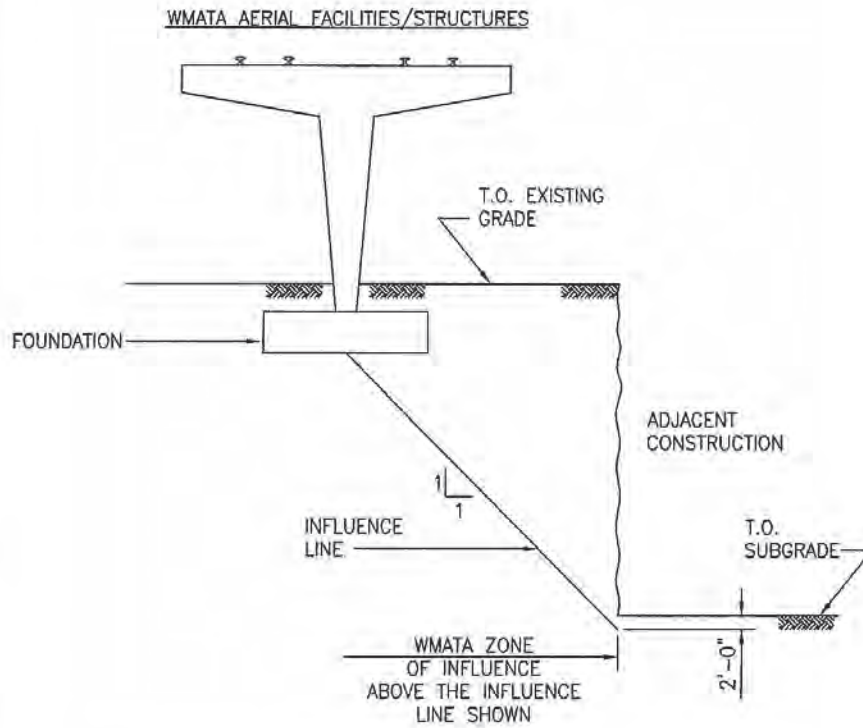

FOR A SITUATION LIKE THE ONE SHOWN HERE, UNDERPINNING WOULD BE REQUIRED PER PLATE A-3A OR PLATE A-3B, UNLESS THE FOUNDATION IS ON PILES EXTENDING AT LEAST 10 FEET BELOW THE 1:1 LINE. ALSO CHECK SLOPE STABILITY.

**WMATA ZONE OF INFLUENCE**

**(CASE E)**

ADJACENT CONSTRUCTION NEAR WMATA AERIAL FACILITIES OR STRUCTURES

WMATA ENGINEERING STANDARDS

**PLATE A-3A**

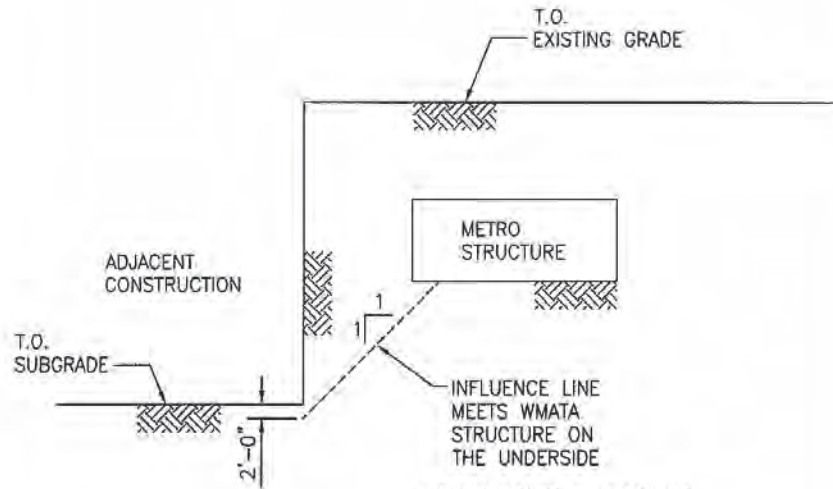

UNDERPINNING IS REQUIRED WHEN THE METRO STRUCTURE FALLS WITHIN THE INFLUENCE LINE OF THE ADJACENT EXCAVATION. (SEE NOTE BELOW.)

NOTE: WHEN THE INFLUENCE LINE HITS THE UNDERSIDE OF THE WMATA STRUCTURE, IT WILL REQUIRE UNDERPINNING. THE UNDERPINNING STRUCTURE MUST RECEIVE THE SUPPORT AT LEAST 5 FEET BELOW THE LINE OF INFLUENCE.

**TUNNEL UNDERPINNING REQUIREMENTS**  
**(CASE A)**

WMATA ENGINEERING STANDARDS

**PLATE A-3B**

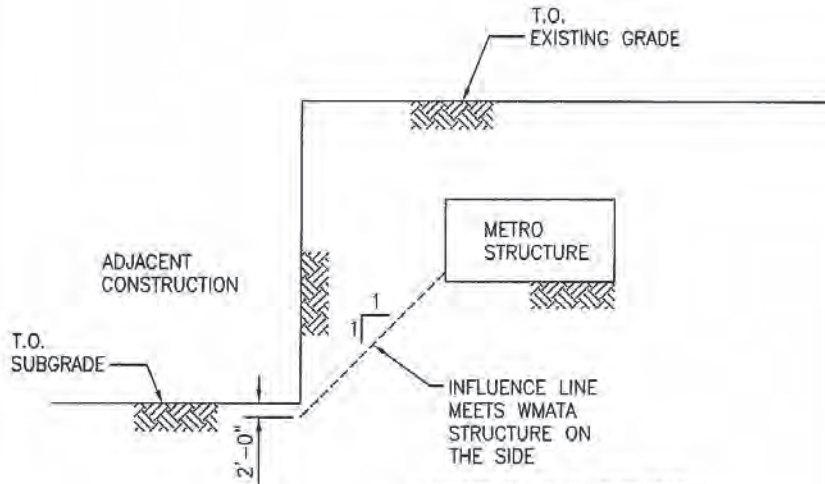

UNDERPINNING IS REQUIRED WHEN THE METRO STRUCTURE FALLS WITHIN THE INFLUENCE LINE OF THE ADJACENT EXCAVATION. (SEE NOTE BELOW.)

NOTE: WHEN THE INFLUENCE LINE HITS THE SIDE OF THE WMATA STRUCTURE, UNDERPINNING IS REQUIRED. THE UNDERPINNING STRUCTURE MUST RECEIVE THE SUPPORT AT LEAST 5 FEET BELOW THE LINE OF INFLUENCE. ALTERNATELY FOR PLATE A-3, CASE B, RIGID SUPPORT OF EXCAVATION MAY BE USED WITH WMATA APPROVAL, IN LIEU OF UNDERPINNING.

**TUNNEL UNDERPINNING REQUIREMENTS**  
**(CASE B)**

WMATA ENGINEERING STANDARDS

**PLATE A-4**

**CASE A:**

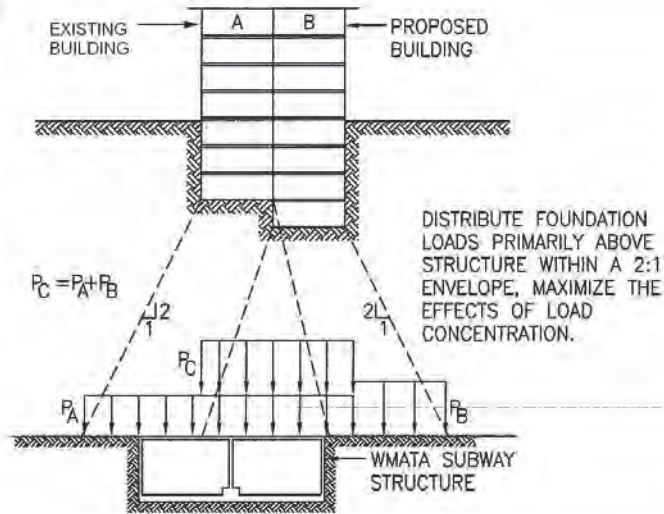

**CASE B:**

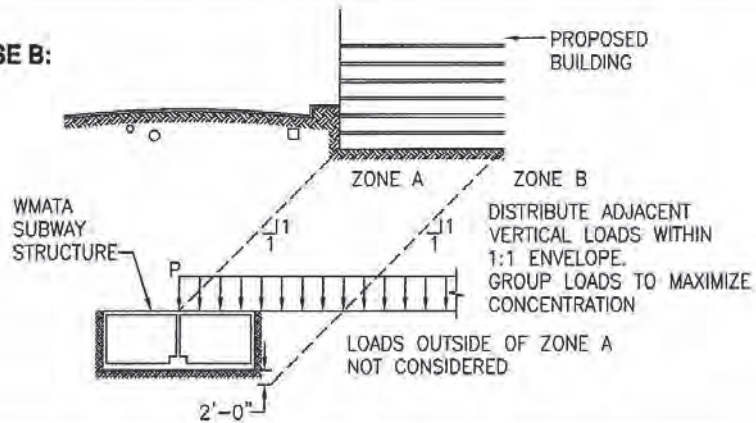

NOTE: EFFECTS OF THE LATERAL LOADS, DUE TO THESE VERTICAL LOADS, SHALL BE CONSIDERED ALONG WITH THE VERTICAL PRESSURES SHOWN HERE ON WMATA STRUCTURES.

**DISTRIBUTION OF VERTICAL PRESSURES**

WMATA ENGINEERING STANDARDS

**PLATE A-5A**

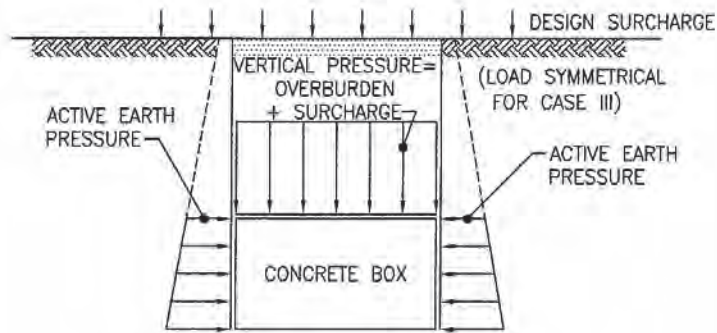
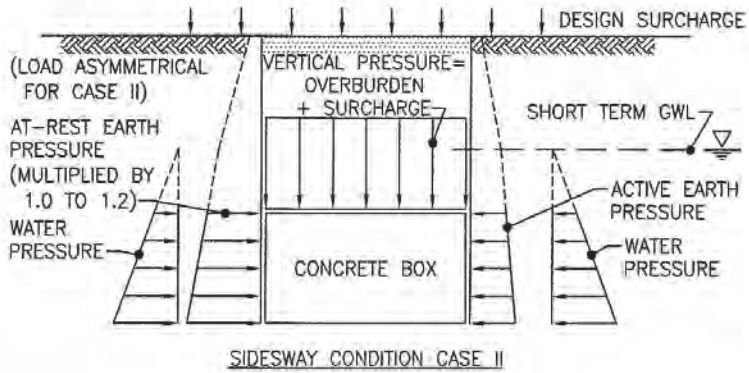

FOR SHORT TERM LOADING, CASE III, USE SYMMETRICAL ACTIVE EARTH PRESSURES ON SIDES, ASSUMING NO WATER PRESSURES.

**SHORT TERM LOADING  
CONCRETE BOX TUNNEL AND OTHER CUT & COVER STRUCTURES**

(SEE DESIGN CRITERIA SECTION V.5.04 FOR DETAILS)

WMATA ENGINEERING STANDARDS

**PLATE A-5B**

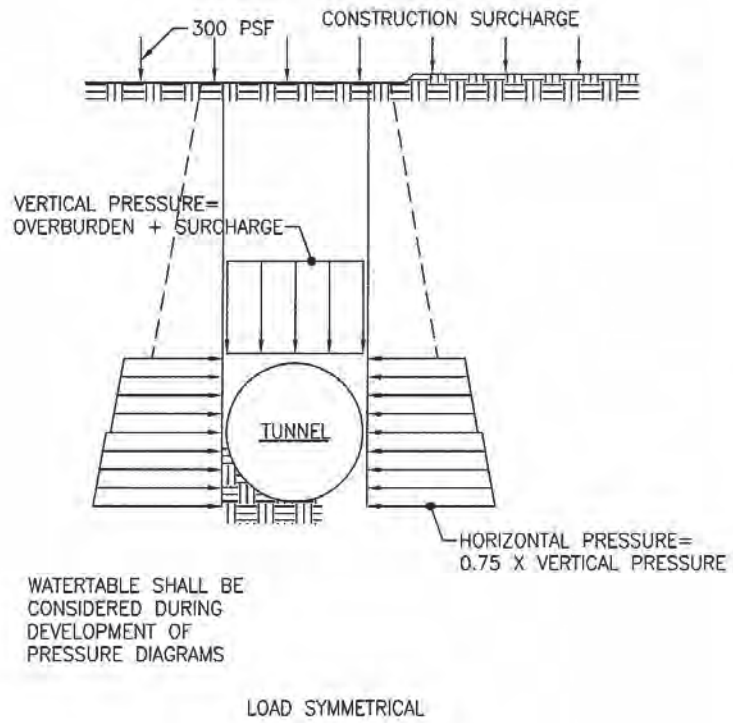

**SHORT TERM LOADING**  
**BORED TUNNEL**

WMATA ENGINEERING STANDARDS

**APPENDIX -3**

**PLATE A-6A**

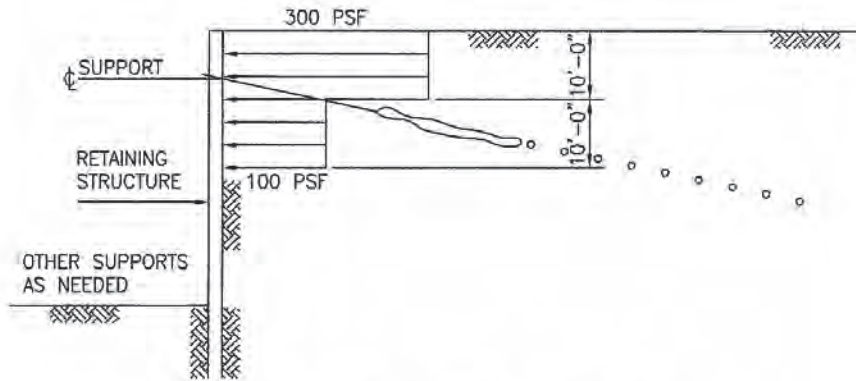

THIS LATERAL PRESSURE IS BASED UPON AN ASSUMED TRAFFIC AND CONSTRUCTION EQUIPMENT SURCHARGE OF 600 PSF.

A SPECIAL ANALYSIS MUST BE MADE FOR MORE SEVERE CONSTRUCTION LOADS.

NOTE: A MINIMUM LATERAL LOAD FROM TRAFFIC AND CONSTRUCTION EQUIPMENT SHALL BE AS SHOWN IN PLATE A-6A. FOR HEAVIER LOADS, THE LATERAL LOADS AS SHOWN IN PLATE A-6B SHALL BE USED, UNLESS A MORE RIGOROUS ANALYSIS IS DONE WITH THE APPROVAL OF WMATA.

**TRAFFIC AND CONSTRUCTION EQUIPMENT LOADS**

WMATA ENGINEERING STANDARDS



PLATE A-6B

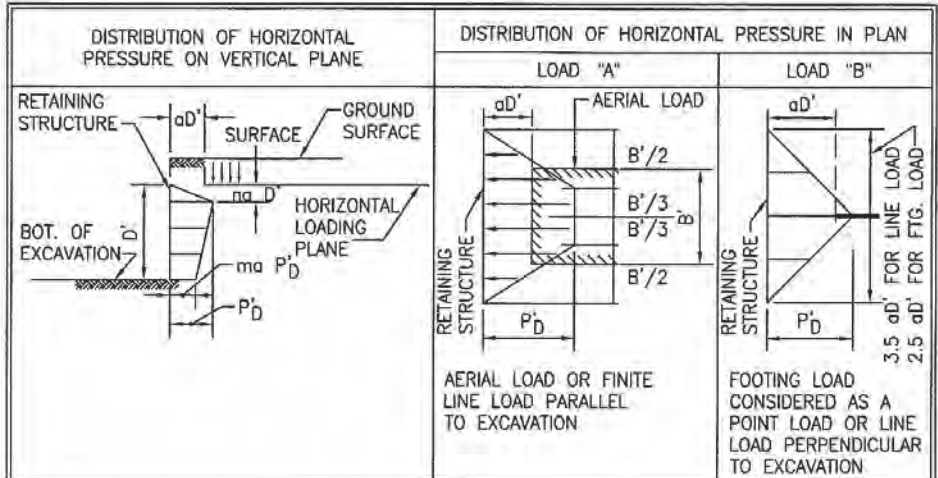

PARAMETERS	n	m	$P'_D$	LOAD TYPE
ISOLATED (INDIVIDUAL) FOOTING CONSIDERED AS POINT LOAD	0.6	0.4	$(2.1-1.8a) Q'/D'^2$	LOAD "B"
CONTINUOUS FOOTING CONSIDERED AS LINE LOAD PARALLEL TO RETAINING STRUCTURE	0.4	0.25	$(1.1-0.5a) Q'/D'$	LOAD "A"
AERIAL LOAD	0.4	0.25	$(0.8-0.5a) Q'/D'$	LOAD "A"
CONTINUOUS FOOTING CONSIDERED AS LINE LOAD PERPENDICULAR TO RETAINING STRUCTURE	0.6	0.4	$(1.4-1.2a) Q'/D'^2$	LOAD "B"

SURCHARGE LOADING PARAMETERS

LEGEND

- $aD'$  = DISTANCE OF RETAINING STRUCTURE TO NEAREST EDGE OF SURCHARGE LOAD
- $Q'$  = TOTAL LOAD PER FOOT OF LENGTH PARALLEL WITH RETAINING STRUCTURE (LOAD "A"), OR TOTAL FOOTING LOAD (LOAD "B")
- $a, n, m$  = DIMENSIONLESS FACTORS

HORIZONTAL PRESSURE ON RETAINING STRUCTURE NEED NOT BE CONSIDERED FOR SURCHARGE LYING AT A DISTANCE OF  $D'+2'$  OR MORE, FROM THE RETAINING STRUCTURE.

**BUILDING OR CONSTRUCTION LOADS**

WMATA ENGINEERING STANDARDS

PLATE A-7A

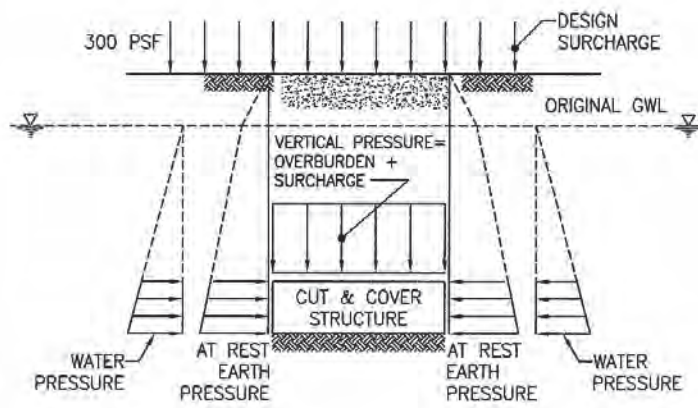

MULTIPLY AT REST EARTH PRESSURE BY FACTOR 1.0 OR 1.2,  
(WHICHEVER PRODUCES THE MOST CRITICAL STRESSES)

**LONG TERM LOADING**  
**CONCRETE BOX TUNNEL AND OTHER CUT & COVER STRUCTURES**

WMATA ENGINEERING STANDARDS

**PLATE A-7B**



VERTICAL PRESSURE =  
OVERBURDEN + SURCHARGE  
IN COMPACT GRANULAR  
MATERIALS. IN FINE  
GRAINED SOILS APPLY  
VERTICAL PRESSURE  
AT THE SPRING LINE.

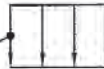

SYMMETRICAL LOADS

OVERBURDEN UNIT WEIGHT  
INCLUDING WATER = 130#/CF

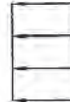

HORIZONTAL PRESSURE  
0.85/APPLIED VERTICAL  
PRESSURE

NOTE: FOR ADEQUACY CHECK OF ALL TWO-PASS SYSTEM  
TUNNELS, THE FINAL LINER ONLY SHALL BE  
CONSIDERED AS RESISTING LOADS.

**LONG TERM LOADING**  
**BORED TUNNEL**

WMATA ENGINEERING STANDARDS

PLATE A-8A

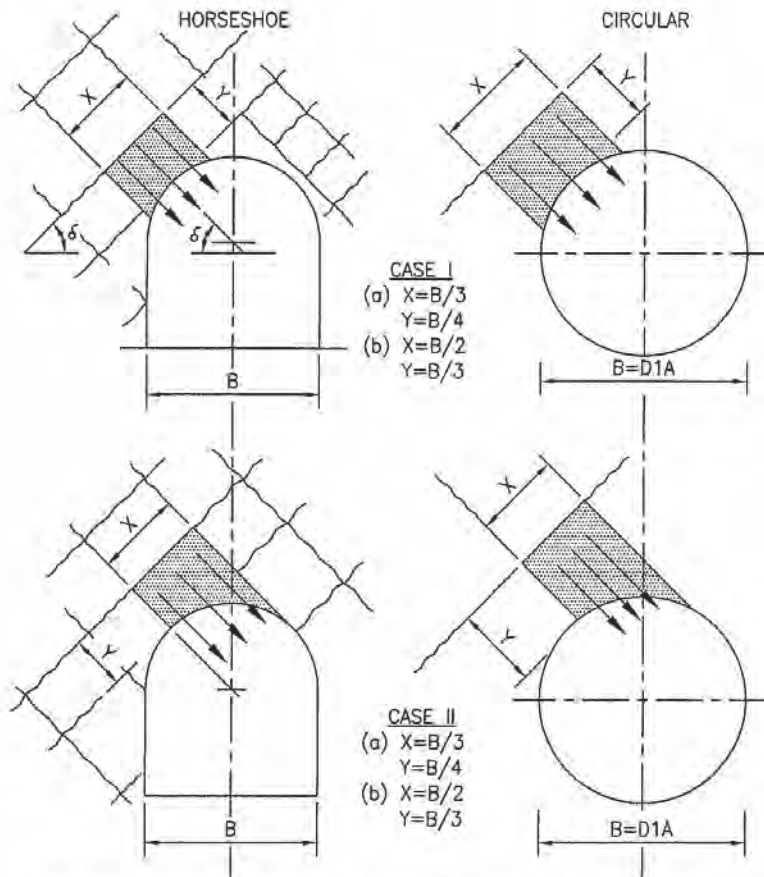

FOR CASES I & II, ANGLE  $\delta$  TO BE DETERMINED FROM SUBSURFACE DATA  
 NOTE: FRICTION ANGLE OF 15° AT SLIDING JOINTS CASE I THRU III.

**LOADING CONDITIONS - RUNNING TUNNELS IN ROCK**

WMATA ENGINEERING STANDARDS

PLATE A-8B

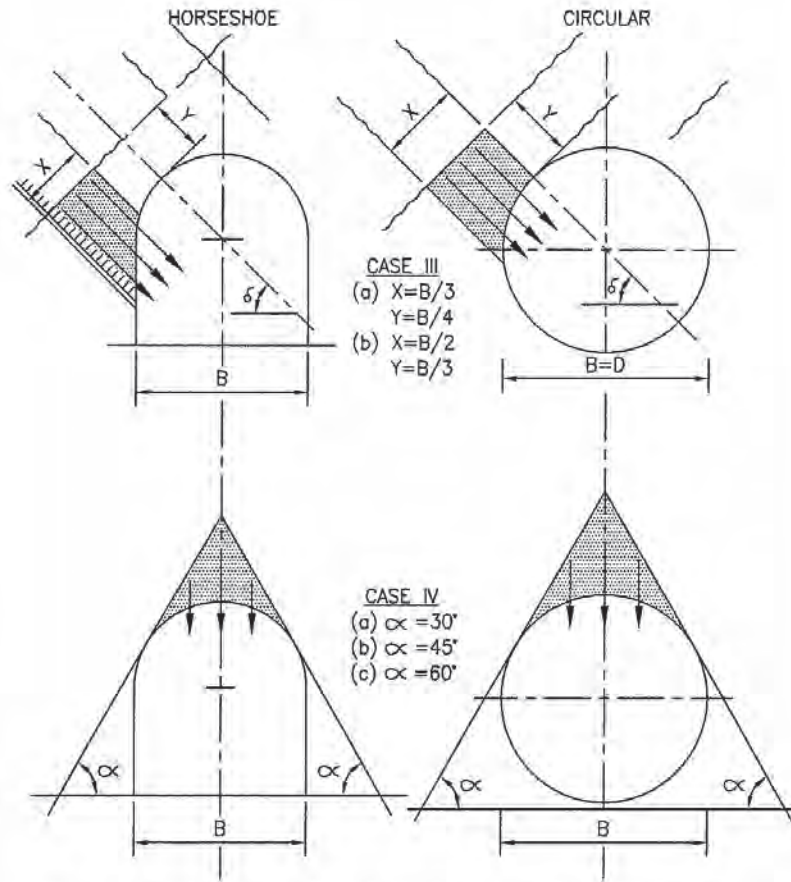

FOR CASES III, ANGLE  $\delta$  TO BE DETERMINED FROM SUBSURFACE DATA

**LOADING CONDITIONS - RUNNING TUNNELS IN ROCK**

WMATA ENGINEERING STANDARDS

PLATE A-8C

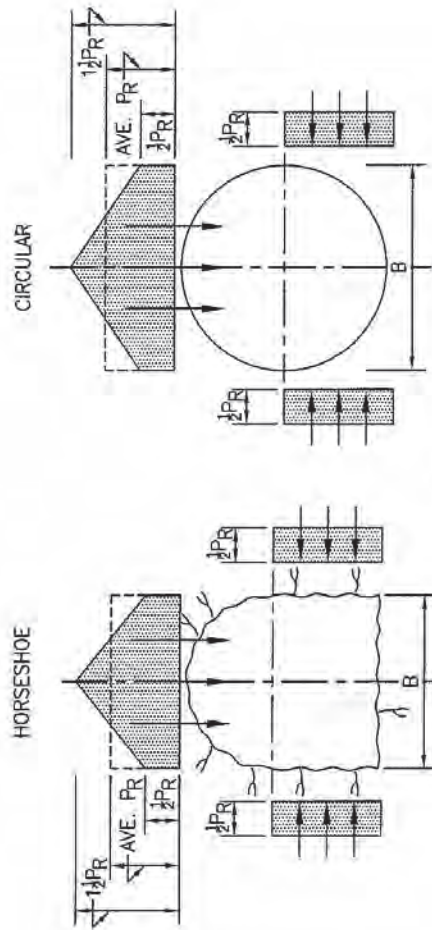

CASE V

$P_R$  = TABULATED AVERAGE VERTICAL ROCK PRESSURE, SEE TABLE A-1

**LOADING CONDITIONS - RUNNING TUNNELS IN ROCK**

WMATA ENGINEERING STANDARDS

PLATE A-8D

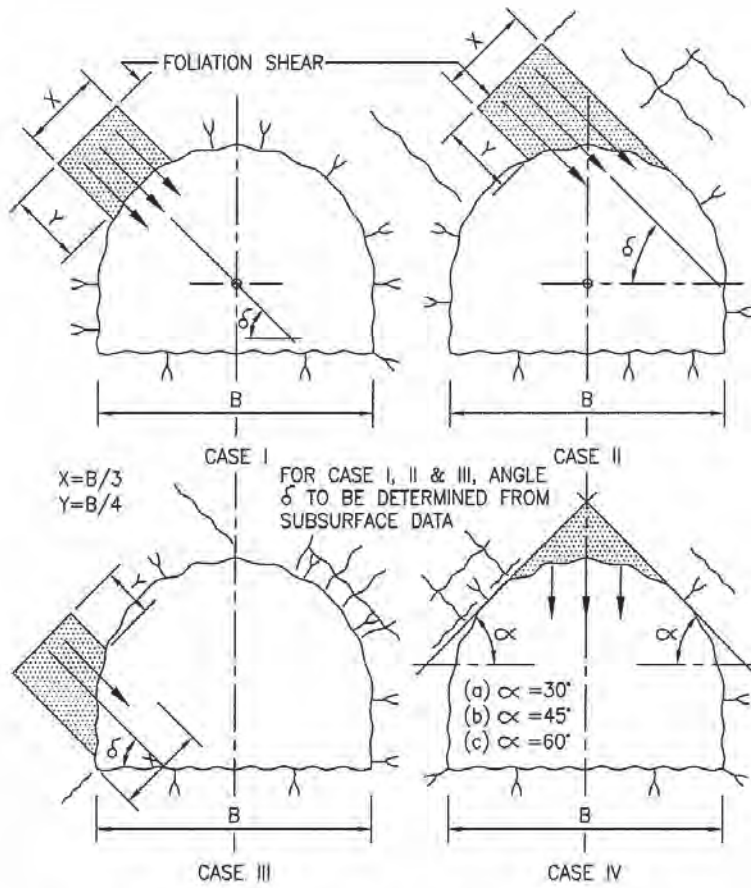

NOTE: FRICTION ANGLE OF 15° AT SLIDING JOINTS(CASE I THRU III)

**LOADING CONDITIONS - STATIONS**

WMATA ENGINEERING STANDARDS

APPENDIX - 3

**PLATE A-8E**

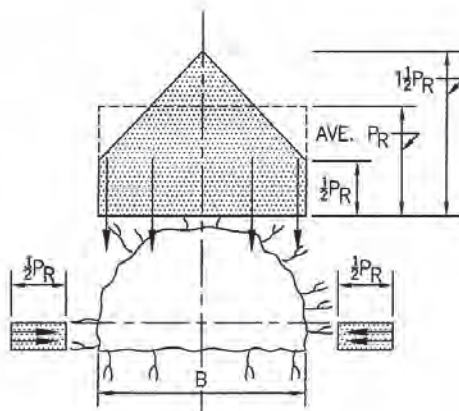

CASE V

$P_R$  = TABULATED AVERAGE VERTICAL ROCK PRESSURE, SEE TABLE A-1

**LOADING CONDITIONS - STATIONS**

WMATA ENGINEERING STANDARDS



**PLATE A-9**

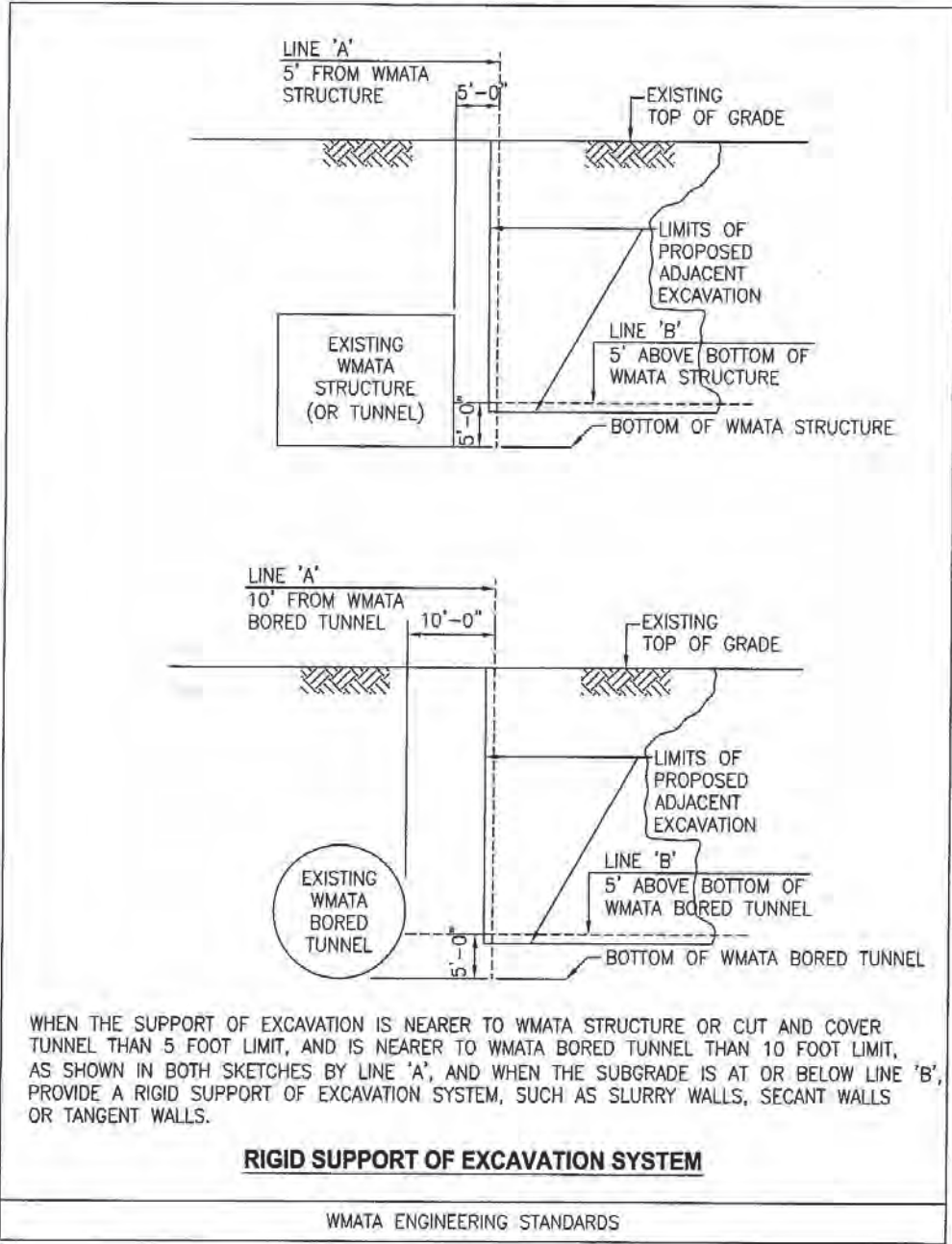

WHEN THE SUPPORT OF EXCAVATION IS NEARER TO WMATA STRUCTURE OR CUT AND COVER TUNNEL THAN 5 FOOT LIMIT, AND IS NEARER TO WMATA BORED TUNNEL THAN 10 FOOT LIMIT, AS SHOWN IN BOTH SKETCHES BY LINE 'A', AND WHEN THE SUBGRADE IS AT OR BELOW LINE 'B', PROVIDE A RIGID SUPPORT OF EXCAVATION SYSTEM, SUCH AS SLURRY WALLS, SECANT WALLS OR TANGENT WALLS.

**RIGID SUPPORT OF EXCAVATION SYSTEM**

WMATA ENGINEERING STANDARDS

### PLATE L-1

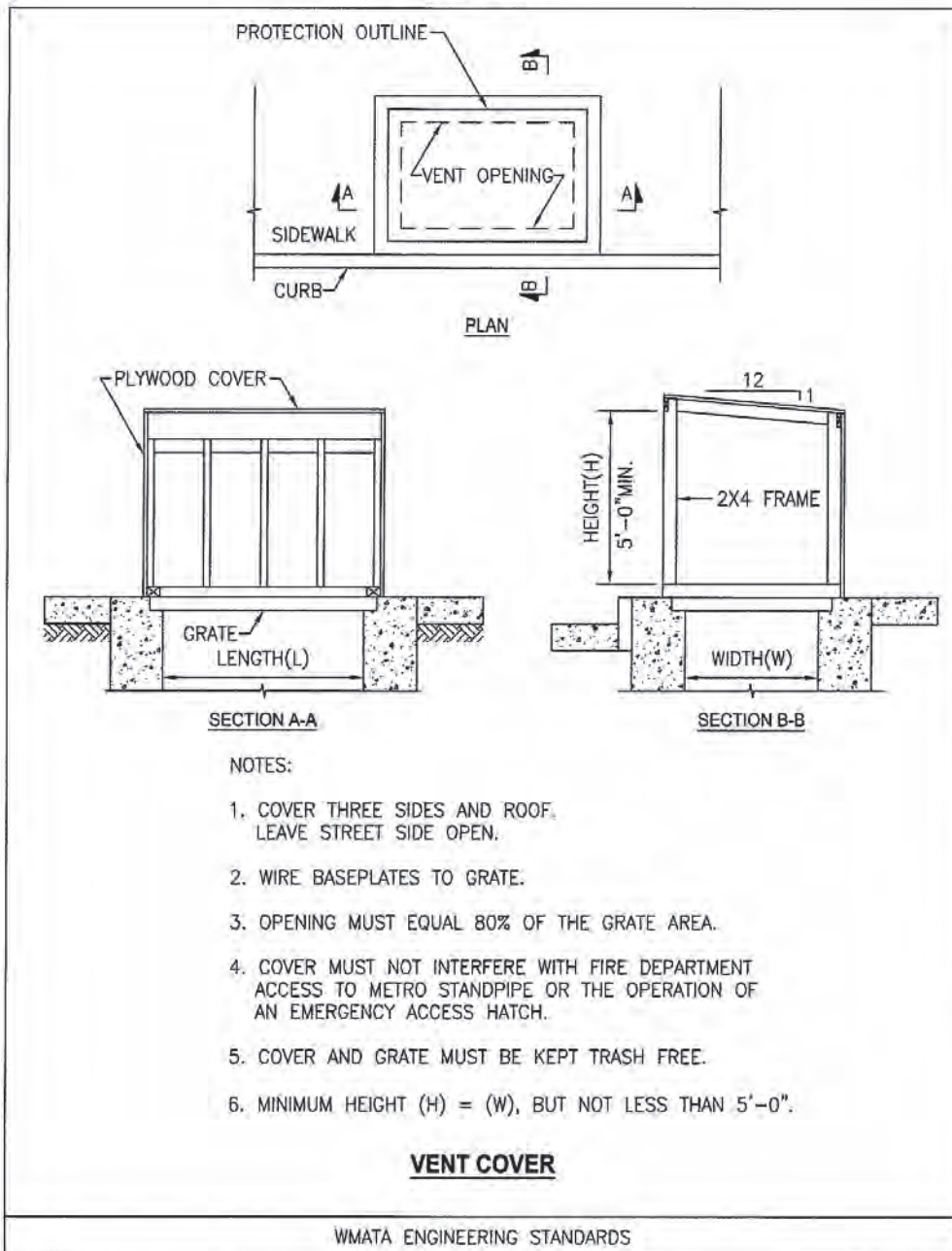

## Plate E-1

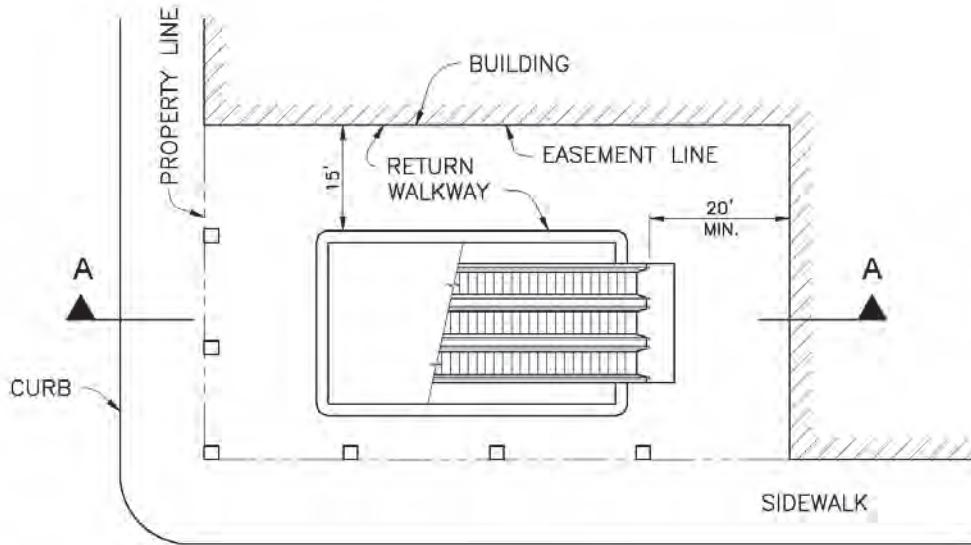

PLAN

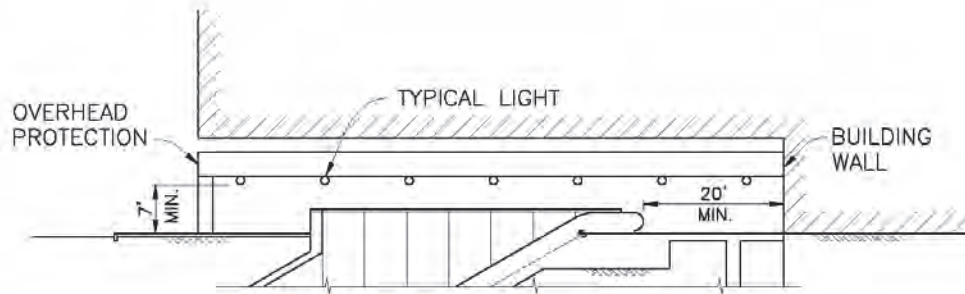

SECTION A-A

1. MAINTAIN 15'-0" RETURN WALKWAY WIDTH FOR PEDESTRIAN ACCESS.
2. MAINTAIN 20'-0" WALKWAY FROM TOP OF ESCALATOR TO SIDEWALK.
3. MAINTAIN A LIGHT LEVEL OF 10 FOOT CANDLES AT ESCALATOR TREADS, OR WALKING SURFACE.

### OVERHEAD PROTECTION ESCALATORS AWAY FROM STREET

## Plate E-2

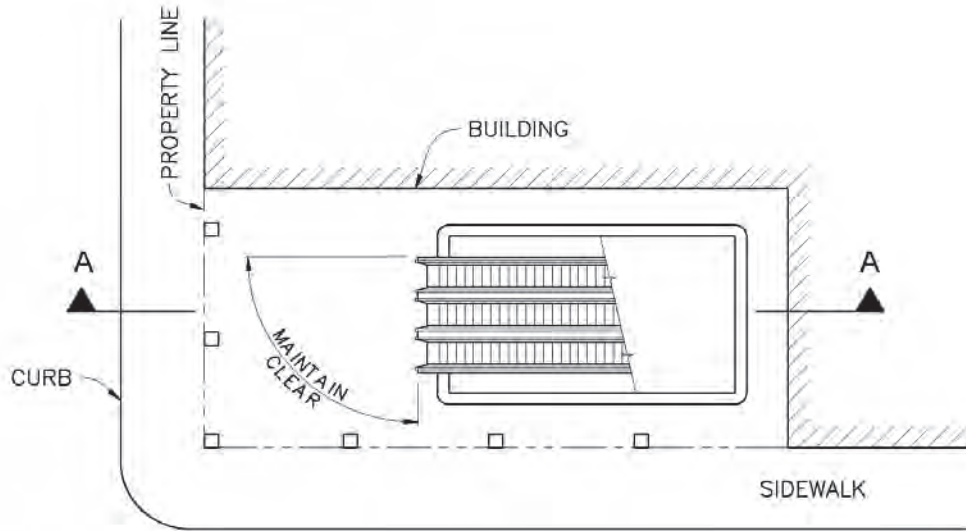

PLAN

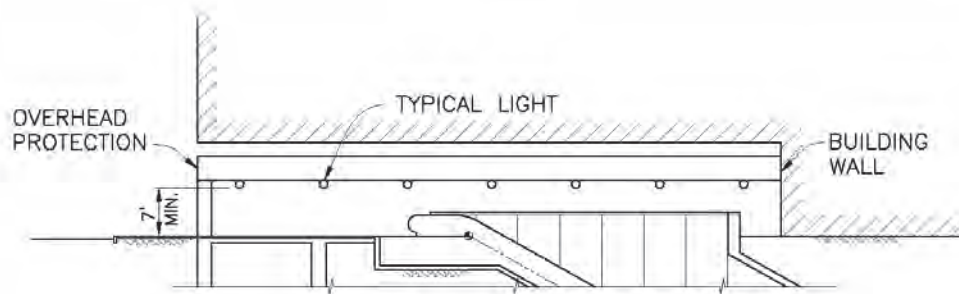

SECTION A-A

1. MAINTAIN CLEAR WALKWAY FROM TOP OF ESCALATOR TO SIDEWALK.
2. MAINTAIN A LIGHT LEVEL OF 10 FOOT CANDLES AT ESCALATOR TREADS, OR WALKING SURFACE.

### OVERHEAD PROTECTION ESCALATORS TOWARD STREET

Table 3-1: AVERAGE VERTICAL LOAD ON ROCK TUNNELS

TUNNEL TYPE		Single Track	Double Track	Station
Excavation Dimensions		20' Wide 18' High	35' Wide 24' High	70' Wide 40' High
Type I Lining: Minimum Cover of "Relatively Sound or sound Rock" required for Type I lining. (See Note 4)		10'	15'	30'
Type II Lining: Type II lining is used for the following conditions		AVERAGE VERTICAL LOAD $P_R$		
(A)	Portal Sections, or where rock cover of any quality is $\leq 0.4$ of minimum rock cover for Type 1 lining, or where thicker rock cover is highly jointed and weathered.	Full Overburden $\Sigma V$	Full Overburden $\Sigma V$	Full Overburden $\Sigma V$
(B)	Rock cover "relatively sound or sound" is $\geq 0.4$ , but is $\leq 0.6$ of minimum rock cover for Type I lining.	$(0.15) \times (\Sigma V)$	$(0.30) \times (\Sigma V)$	$(0.60) \times (\Sigma V)$
(C)	Rock cover "relatively sound or sound" is $\geq 0.6$ , but is $\leq 0.8$ of minimum rock cover for Type I lining.	$(0.10) \times (\Sigma V)$	$(0.20) \times (\Sigma V)$	$(0.40) \times (\Sigma V)$
(D)	Rock cover "relatively sound or sound" is $\geq 0.8$ , but is $\leq 1.0$ of minimum rock cover for Type I lining.	$(0.05) \times (\Sigma V)$	$(0.10) \times (\Sigma V)$	$(0.20) \times (\Sigma V)$
(E)	Rock cover $\geq 1.0$ of minimum rock cover for Type I lining, but is not "relatively sound or sound" at tunnel top.	0.5 ksf	1.0 ksf	2.0 ksf

Notes:

- (1)  $\Sigma V$  = Total pressure of overburden, soil plus rock, above tunnel top.
- (2) Rock described in D. U. Deer report of November 1, 1967 as "good to excellent" with RQD values greater than 65 to 75 percent generally qualifies as "relatively sound or sound" rock cover.
- (3) Rock described on the geological sections in the WMATA soils reports prepared by MRCE, as "relatively sound or sound", with RQD values greater than 60 to 70 percent generally qualifies as "relatively sound or sound" rock cover
- (4) No vertical load is considered for the design of the tunnel lining, in "relatively sound or sound" or better rock and is called Type I lining.

**Table 3-2: MODULUS OF SUBGRADE REACTION**

STRATUM	MODULUS OF SUBGRADE REACTION - KCF
Fill, organic soils, T0, T1 Clays with Shear Strength of 1.5 KSF or less.	75
Stiff T1 Clay, Coarse-grained Pleistocene Terrace Materials	150
Cretaceous Strata	200
Decomposed Rock, Thoroughly Weathered Rock	300

This page intentionally blank.

TABLE 3-3: SOIL PROPERTIES FOR DESIGN

TABLE V-2 SOIL PROPERTIES FOR DESIGN											
UNIFIED SOIL CLASSIFICATION	SHORT DESCRIPTION	MRWJ+ SYMBOLS	FULL DESCRIPTION/SOURCE/AGE	SHEAR STRENGTH AND CONSOLIDATION CONDITION OF A COHESIVE STRATA	MIN. UNIT WEIGHT (pcf)	COEF OF SUBGRADE REACTION (KCF)	UNDRAINED SHEAR STRENGTH (KSF)	YOUNG MOD. OF SUBGRADE (KSF)	COEF. OF AT REST PRESS.	MAX. EFFECTIVE ANGLE OF FRICTION (DEGREES)	MAX. ALLOWABLE BEARING CAPACITY (TSF)
PRIMARY	SECONDARY										
			FILL								
ML & SM	FILL	F	FILL, GENERALLY COMPOSED OF INORGANIC SOIL OBTAINED FROM NEAR BY NATURAL TERRACE, CRETACEOUS SOIL OR DECOMPOSED ROCK.	PLACED OVER MARSH, MIXED WITH CINDERS. NO CONSOLIDATION	120					28	NONE, ORDINARILY
				FROM PLEISTOCENE SOILS	130					30	1.0 TO 1.50
				FROM DECOMPOSED ROCK (NW OF ROCK CREEK)	130					30	1.5 TO 2.0
				FROM CRETACEOUS CLAYS (NEAR UNION STATION). MAX. SHEAR STRENGTH, COHESIVE STRATA: 0.8 KSF	130					25	0.75
				MIXED WITH ORGANIC SOILS (SOUTH OF ROSSLYN)	120					28	
				OTHER LOCATIONS	130					30	1.0 TO 1.50
				RIVER ALLUVIUM OF POST GLACIAL TIMES.							
CL, CH, OH	ORGANIC CLAY	A1	VERY SOFT TO MEDIUM STIFF DARK GRAY ORGANIC CLAY WITH LENSES OF HIGHLY ORGANIC MATERIAL (WHERE LOCATED UNDER WATER). SOFT TO STIFF MOTTLED GRAY-BROWN SLIGHTLY ORGANIC SILTY OR SANDY CLAY (WHERE LOCATED IN LAND).	BENEATH FILL OVER CONSOLIDATED 0.2 TO 0.3 TSF. STRENGTH 0.5 TO 0.7 KSF.	120					23	NONE, ORDINARILY
	ORGANIC CLAY			BENEATH WATER OVER CONSOLIDATED AS MUCH AS 0.2 TSF. STRENGTH 0.2 TO 0.3 KSF.	110					23	NONE
	ORGANIC CLAY			MAX. SHEAR STRENGTH COHESIVE STRATA: 0.9 KSF	120					23	0.75
SM	SILTY SAND	A1	LOOSE TO MEDIUM COMPACT GRAY OR DARK BROWN SILTY FINE TO MEDIUM SAND WITH OCCASIONAL POCKETS OR LENSES OF SMALL GRAVEL. MAY BE SLIGHTLY TO MODERATELY ORGANIC.		130					30	2 TO 2.5
	SILTY SAND				130					30	2



TABLE 3-3: SOIL PROPERTIES FOR DESIGN

TABLE V-2 SOIL PROPERTIES FOR DESIGN											
UNIFIED SOIL CLASSIFICATION	SHORT DESCRIPTION	MRV#* SYMBOLS	FULL DESCRIPTION/SOURCE/AGE	SHEAR STRENGTH AND CONSOLIDATION CONDITION OF A COHESIVE STRATA	MIN. UNIT WEIGHT (PCF)	COEF OF SUBGRADE REACTION (KCF)	UNDRAIN D SHEAR STRENGTH (KSF)	YOUNG MOD. OF SUBGRADE (KSF)	COEF. OF FLT BEARING PRESS.	MAX. EFFECTIVE ANGLE OF SHEAR (DEGREES)	MAX. ALLOWABLE BEARING CAPACITY (KSF)
			PORTIONS OF THE "25-FOOT", "50-FOOT" AND "90-FOOT" TERRACES, DEPOSITED BY RIVERS IN PLEISTOCENE TIMES.								
CH & OH		T0	MEDIUM STIFF TO STIFF DARK GRAY ORGANIC CLAY WITH NUMEROUS WOOD FRAGMENTS, USUALLY FOUND INTERLENSED WITH STRATUM T4.	MAX. SHEAR STRENGTH, COHESIVE STRATA: 1.4 KSF	130					25	1.2 TO 1.5
CL, CL& CH		T1	STIFF TO MEDIUM STIFF LIGHT BROWN OR GRAY OR MOTTLED BROWN-GRAY SILTY CLAY OR CLAYEY SILT WITH LENSES OF BROWN SILT FINE SAND. IN SOME AREAS, SEVERAL SEPARATE LAYERS OF PLEISTOCENE CLAYSHAVE BEEN ENCOUNTERED, WHICH ARE DISTINGUISHED BY A LETTER SUFFIX: T1A, T1C, ETC.								
	SILTY SAND			(DEPTH: 0 TO 40 FT) MAX. SHEAR STRENGTH, COHESIVE STRATA: 1.0 KSF TO 1.5 KSF	130					25	1.5 TO 2.0
	SILTY SAND			(DEPTH > 40 FT) MAX. SHEAR STRENGTH, COHESIVE STRATA: 1.0 TO 1.5 KSF	130					25	1.0 TO 1.5
	SILTY CLAY	T1 (A) & (G)		OVERCONSOLIDATED 3 TO 5 TSF. STRENGTH 1.5 TO 2.5 KSF, HIGHER NEAR SURFACE.	130					25 TO 28	1.50 TO 2.50
	ORGANIC CLAY	T1 (B)		OVERCONSOLIDATED 1.5 TO 2.5 TSF. STRENGTH 2 TO 3 KSF.	130					25	2
	SILTY CLAY	T1 (C) & (F)		OVERCONSOLIDATED 0.5 TO 1 TSF. STRENGTH 0.7 TO 0.9 KSF, HIGHER AT SURFACE.	130	150				25	1 OR LESS
	PLASTIC CLAY	T1 (D)		OVERCONSOLIDATED 2.5 TO 3.0 TSF. STRENGTH 2.5 TO 3.5 KSF.	130					25	2.0 TO 3.0
	MEDIUM PLASTIC CLAY	T1 (E)		OVERCONSOLIDATED 3.0 TSF. STRENGTH 2 TO 3 KSF.	130					25	2.0 TO 2.50
SM & SC	SILTY SAND	T2	MEDIUM COMPACT TO VERY COMPACT BROWN AND RED-BROWN SILTY OR CLAYEY FINE TO MEDIUM SAND WITH TRACES OF GRAVEL AND OCCASIONAL BOULDERS		130					34	2.0 TO 3.0
SW & SM	GRGVELLY SAND	T3	RED BROWN FINE TO COARSE SAND WITH SOME SILT AND SMALL GRAVEL AND VARIABLE AMOUNTS OF COBBLES AND BOULDERS.		130	170				34-38	3.5 TO 4.0
SM & SP	SILTY SAND	T4	MEDIUM COMPACT TO COMPACT GRAY AND GRAY-BROWN FINE TO MEDIUM SAND WITH SOME SILT AND SMALL GRAVEL, CONTAINING LENSES OF DARK GRAY CLAY. OCCASIONALLY SLIGHTLY ORGANIC.		130					30 TO 34	2.0 TO 3.0

TABLE 3-3: SOIL PROPERTIES FOR DESIGN

TABLE V-2 SOIL PROPERTIES FOR DESIGN										
UNIFIED SOIL CLASSIFICATION	SHORT DESCRIPTION	MRV/S+ SYMBOLS	SHEAR STRENGTH AND CONSOLIDATION CONDITION OF A COHESIVE STRATA	MIN. UNIT WEIGHT (pcf)	COEFF. OF SUBGRADE REACTION (k/cf)	UNDRAINED SHEAR STRENGTH (ksf)	YOUNG MOD. OF SUBGRADE (ksf)	COEFF. OF REST PRESS.	MAX. EFFECTIVE ANGLE OF REST (DEGREES)	MAX. ALLOWABLE DEFORMING CAPACITY (INCH)
SW & SM SP & GM	GRAVELLY SAND	T5	FULL DESCRIPTION: SOURCE AGE COMPACT TO VERY COMPACT GRAY AND GRAY-BROWN FINE TO COARSE SAND WITH SOME GRAVEL, SOME TO TRACES OF SILT AND VARIABLE AMOUNTS OF COBBLES AND BOULDERS, OFTEN CONCENTRATED AT BASE OF LAYER.	130					32 - 38	2.5 TO 4.0
SM & SC	SILTY SAND	Q1	BRANDYWINE FORMATION OF EARLY PLEISTOCENE OR PLOCENE TIMES.							
SM & SC	GRAVELLY SAND	Q2	LOOSE TO MEDIUM COMPACT LIGHT BROWN SILTY OR CLAYEY FINE TO MEDIUM SAND WITH TRACE OF SMALL GRAVEL. LOOSE TO MEDIUM COMPACT LIGHT BROWN OR TAN SILTY OR CLAYEY MEDIUM TO FINE SAND WITH SOME SMALL GRAVEL.	130	180	0.01-0.02	12-15	0.4	33	3.0
SM & CH		C	MARINE DEPOSITS OF TERTIARY OR UPPER CRETACEOUS PERIODS							
		Cc	MEDIUM COMPACT GRAY AND TANSILTY FINE SAND OR MEDIUM STIFF TO STIFF DARK GRAY TO OLIVE-GREEN CLAY. CALVERT FORMATION OF MIOCENE AGE.	130	100	1.5-2.5	6-8	0.55	25	1.5-2.0
		Cs	PLASTIC CLAY, SILTY AND SANDY CLAY OR CLAYEY SILT	130	140		8-10	0.5	30-32	1.5 -2.0
MH & CL		E	FINE SAND, TRACE TO SOME SILT. CLAY AND CLAYEY FINE SAND							
		E1	AQUIA FORMATION OF EOCENE AGE.							
		E2	MEDIUM STIFF DARK GREEN OR BROWN CLAY AND SILTY CLAY. AQUA FORMATION OF EOCENE AGE.	130	140		8-10	0.5	30-32	1.5-2.0
				130	100	2.0-3.5	6-8	0.55	25	1.5 -2.0
MH & CH		M	UPPER CRETACEOUS PERIOD							
		Mc	MEDIUM STIFF TO STIFF GREEN OR BROWN SILTY SAND CLAY. MONMOUTH FORMATION OF UPPER CRETACEOUS AGE.	130	120	3.0-3.5	8-10	0.6	25	2.0-4.0
		Ms	SLIGHTLY ORGANIC FINE SANDY SILT AND CLAYEY SILT	130	160		10-12	0.45	32-34	2.0-4.0
			SLIGHTLY ORGANIC MICA CE OUS SILTY OR CLAYEY FINE SAND							
			POTOMAC GROUP OF CRETACEOUS PERIOD,							

TABLE 3-3: SOIL PROPERTIES FOR DESIGN

TABLE V-2 SOIL PROPERTIES FOR DESIGN											
UNEID SOIL CLASSIFICATION	SHORT DESCRIPTION	MRWJ* SYMBOLS	FULL DESCRIPTION/SOURCE/AGE	SHEAR STRENGTH AND CONSOLIDATION CONDITION OF A COHESIVE STRATA	MIN. UNIT WEIGHT (PCD)	COEF OF SUBGRADE REACTION (KCF)	UNDRAINED SHEAR STRENGTH (KSF)	YOUNG MOD. OF SUBGRADE (KSD)	COEF. OF AT REST PRESS.	MAX. EFFECTIVE ANGLE OF FRICTION (DEGREES)	MAX. ALLOWABLE BEARING CAPACITY (TSF)
CH	CL	P1	HARD MOTTLED RED-BROWN AND GRAY LIGHT GRAY AND TAN PLASTIC CLAY WITH OCCASIONAL POCKETS OF FINE SAND. GENERALLY CONSISTS OF PATAFSCO FORMATION BUT MAY INCLUDE EARLIER FORMATION AT UPPER LEVELS.	NORTH & WEST OF NEW JERSEY AVE. OVERCONSOLIDATED 15 TO 30 TSF. STRENGTH 4 TO 5 KSF BUT ERRATIC.	130	200	3.0 TO 5.0	10-15	0.6	25	3.0 TO 5.0
CL	SANDY CLAY				130	200	4.0-4.5	10-14	0.5	30	3.0-5.0
	PLASTIC CLAY			PARTIALLY WEATHERED ALONG B&O RIGHT-OF-WAY IN PHASE VII PROVIDE STRENGTH AND BEARING CAPACITY IN LOWER PORTION OF THE RANGE NOTED.	130					25	2.0 TO 5.0
SM & SP	SILTY SAND	P2	COMPACT TO VERY COMPACT LIGHT GRAY OR TAN SILTY OR CLAYEY FINE TO MEDIUM SAND WITH POCKETS OF SILTY CLAY AND TRACE OF SMALL GRAVEL, OCCASIONAL LIGNITE FRAGMENTS. ALSO INCLUDES MAGOTHY FORMATION OF UPPER CRETACEOUS AGE.		130	200			0.5	33 TO 34	3.5 TO 6.0
G	SAND, SOME GRAVEL				130	200			0.5	34	3.0 TO 6.0
	SILTY SAND				130	200				33 TO 36	3.0 TO 6.0
				OVERCONSOLIDATED 15 TO 20 TSF. STRENGTH 4 TO 6 KSF.	130					34	4.0 TO 7.0
SM & SW	GRAVELLY SAND	P4	VERY COMPACT MOTTLED LIGHT GRAY, TAN OR BROWN SILTY FINE TO MEDIUM SAND WITH SOME GRAVEL AND SCATTERED LIGNITE FRAGMENTS. FREQUENTLY WITH DENSE NESTS AND POCKETS OF ANGULAR ROCK FRAGMENTS, COBBLES AND BOULDERS.		135					34 TO 38	4.0 TO 7.0
			WEATHERED IN-SITU FROM CRYSTALLINE BEDROCK								
			DECOMPOSED ROCK; HARD ORANGE-BROWN OR YELLOW-BROWN MICACEOUS FINE SANDY SILT OR VERY COMPACT LIGHT GRAY AND GREEN MICACEOUS SILTY FINE TO MEDIUM SAND WITH VARIABLE AMOUNTS OF HARD, INCOMPLETELY DECOMPOSED ROCK FRAGMENTS AND LENSES. PROPORTION OF HARD ROCK FRAGMENTS INCREASES WITH DEPTH TOWARD THE BEDROCK SURFACE.								
ML & SM	MH	D	DECOMPOSED ROCK	HIGH-QUASE-OVERCONSOLIDATED STRENGTH INCREASE WITH DEPTH: 1.5 KSF TO 3.5 KSF AND MORE.	140					36	5

**TABLE 3-3: SOIL PROPERTIES FOR DESIGN**

TABLE V-2 SOIL PROPERTIES FOR DESIGN											
UNEID SOIL CLASSIFICATION	SHORT DESCRIPTION	MRWJ* SYMBOLS	FULL DESCRIPTION/SOURCE/AGE	SHEAR STRENGTH AND UNIT WEIGHT	MIN. WEIGHT (PCF)	COEF OF SUBGRADE REACTION (K/CF)	UNDRAINED SHEAR STRENGTH (K/FS)	YOUNG MOD. OF SUBGRADE (K/SI)	COEF. OF AT REST PRESS.	MAX. EFFECTIVE ANGLE OF FRICTION (DEGREES)	MAX. ALLOWABLE BEARING CAPACITY (T/SF)
REQUIRE DIAMOND CORE DRILLING TO ADVANCE BOREHOLE			TRANSITION ZONE								
	WEATHERED & JOINTED BEDROCK	WR	WEATHERED AND JOINTED BEDROCK. WEATHERING ALONG JOINTS AND ALSO AFFECTING THE MINERAL FABRIC. RQD GENERALLY LESS THAN 50%.	BECOMING MORE ROCK LIKE WITH DEPTH, TOO HARD TO OBTAIN SOIL SAMPLE FOR TEST.	150 TO 100					32 TO 38	5.0 TO 15.0
	JOINTED BEDROCK	J	JOINTED TO MODERATELY JOINTED BEDROCK. WEATHERING ON JOINTS BUT RELATIVELY SMALL EFFECT ON MINERAL FABRIC. RQD GENERALLY BETWEEN 50% TO 75%.	MODERATELY JOINTED TO RELATIVELY SOUND. COMPRESSIVE STRENGTH 5 TO 25 KSI.	170					45	30.0 TO 60.0
	BEDROCK	R	RELATIVELY SOUND TO SOUND BEDROCK, OCCASIONALLY MODERATELY JOINTED. WEATHERING CONTAINED PRINCIPALLY TO JOINTS. RQD GENERALLY GREATER THAN 75%.	MODERATELY JOINTED TO RELATIVELY SOUND. COMPRESSIVE STRENGTH 5 TO 25 KSI.	170					45	30.0 TO 60.0

1. THIS TABLE IS INTENDED PRIMARILY FOR USE IN DESIGN OF PERMANENT STRUCTURES. IN ANY CASE, SPECIFIC BORING AND LABORATORY TEST INFORMATION AT THE LOCATION OF INTEREST SHOULD BE CONSULTED IN SELECTING THE PARAMETERS FOR DESIGN SINCE THE VALUES TABULATED ABOVE ARE GENERALIZED OVER A WIDE AREA.

2. "SHEAR STRENGTH" TABULATED FOR "COHESIVE STRATA" IS APPROXIMATE UNDRAINED COHESION AND IS NOT INTENDED TO BE COMBINED WITH OR SUPERPOSED ON THE "EFFECTIVE FRICTION ANGLE" FOR DRAINED SHEAR.

3. IN EVALUATING APPLIED PRESSURES OR STABILITY CONDITIONS IN THE TRANSITION ZONE AND VARIOUS BEDROCK ZONES, THE BORING INFORMATION ON ATTITUDE AND CHARACTER OF THE DISCONTINUITIES SHOULD BE TAKEN INTO CONSIDERATION. IF THERE IS EVIDENCE OF SLICKENSIDES, SHEARED ZONES OR SURFACES OR SMOOTH JOINTS DIPPING UNFAVORABLY INTO THE EXCAVATION, EFFECTIVE FRICTION ANGLES ON THESE DISCONTINUITIES CAN BE IN A RANGE OF 10 DEGREES TO 20 DEGREES.

NOTES: a) TABLE IS BASED ON MRW&J\* GEOTECHNICAL INFORMATION FOR THE METRO PREVIOUS PROJECTS.

b) INFORMATION (ALLOWED LIMITS) NOT GIVEN IN THE TABLE SHALL BE PROVIDED BY DESIGNER/DESIGN-BUILDER FOR SPECIFIC PROJECT AS NECESSARY

\*MEUSER RUTLEDGE WENTWORTH & JOHNSTON

Updated: September 6, 2000

This page intentionally blank.

**GENERALIZED STRATA DESCRIPTIONS**

SYMBOL	DESCRIPTION	UNITED SOIL CLASSIFICATION		SOURCE AND AGE	SYMBOL	DESCRIPTION		UNITED SOIL CLASSIFICATION		SOURCE AND AGE
		PRIMARY	SECONDARY			PRIMARY	SECONDARY			
(F)	FILL, GENERALLY OF INORGANIC SOIL OBTAINED FROM NEARBY SOILS OR DECOMPOSED ROCK.	ML, SM	SC, CL	MAN-MADE IN HISTORIC TIMES	(C)	MEDIUM COMPACT GRAY AND TAN SILTY FINE SAND OR MEDIUM TO MEDIUM COMPACT GRAY TO OLIVE GREEN CLAY, CALVERT FORMATION OF MIOCENE AGE.	SM, CH	SP, CL	MARINE DEPOSITS OF TERTIARY OR UPPER CRETACEOUS PERIODS	
(A1)	SOFT TO MEDIUM STIFF DARK GRAY AND BROWN ORGANIC CLAY WITH LENSES OF MEDIUM TO MEDIUM COMPACT BROWN OR MOTTLED GRAY-BROWN SLIGHTLY ORGANIC SILTY OR SANDY CLAY OR SAND.	CL, CH, OH	OL, PE	RIVER ALLUVIUM OF POST-GLACIAL TIMES	(E)	MEDIUM STIFF DARK GREEN OR BROWN CLAY AND SILTY CLAY, AQUIA FORMATION OF EOCENE AGE.	MH, CH	ML, CL	MARINE DEPOSITS OF TERTIARY OR UPPER CRETACEOUS PERIODS	
(A2)	LOOSE TO MEDIUM COMPACT DARK BROWN OR GRAY SILTY FINE TO MEDIUM SAND WITH OCCASIONAL POCKETS OR LENSES OF SMALL GRAVEL.	SM	SP	PORTIONS OF THE "25-FOOT" "50-FOOT" AND "90-FOOT" TERRACES, DEPOSITED BY RIVERS IN PLEISTOCENE TIMES	(N)	MEDIUM STIFF TO STIFF DARK GREEN OR BROWN SILT AND CLAY, MORMOUTH FORMATION OF UPPER CRETACEOUS AGE.	MH, CL	ML, CH	MARINE DEPOSITS OF TERTIARY OR UPPER CRETACEOUS PERIODS	
(T1)	STIFF TO MEDIUM LIGHT BROWN OR GRAY OR MOTTLED BROWN-GRAY SILTY CLAY OR CLAYEY SILT WITH LENSES OF BROWN SILTY FINE SAND.	CL, ML	LENSES OF OL, PE OR SC		(P1)	HARD MOTTLED RED-BROWN AND GRAY OR LIGHT GRAY AND TAN PLASTIC CLAY WITH OCCASIONAL POCKETS OF FINE SAND. GENERALLY CONSISTS OF PATAPSCO FORMATION BUT MAY INCLUDE EARLIAN FORMATION AT HIGHER LEVELS.	CH	CL	POTOMAC GROUP OF CRETACEOUS PERIOD	
(T2)	MEDIUM COMPACT TO COMPACT BROWN AND ORANGE-BROWN SILTY OR CLAYEY FINE TO MEDIUM SAND WITH TRACES OF SMALL GRAVEL.	SM, SC	SP, SM		(P2)	COMPACT TO VERY COMPACT LIGHT GRAY OR TAN SILTY OR CLAYEY FINE TO MEDIUM SAND WITH POCKETS OF SILTY CLAY AND TRACE OF SMALL GRAVEL, OCCASIONAL LIMONITE FRAGMENTS, INCLUDES ALSO MAGOTHY FORMATION OF UPPER CRETACEOUS.	SM, SP	SP	POTOMAC GROUP OF CRETACEOUS PERIOD	
(T3)	COMPACT TO VERY COMPACT BROWN AND RED-BROWN FINE TO COARSE SAND WITH SOME SILT AND GRAVEL, OR SAND AND GRAVEL WITH A TRACE OF SILT AND NUMEROUS BOULDERS.	SM, SN	SP, GM		(P3)	HARD GRAY-GREEN OR GRAY-BLUE SILTY OR SANDY CLAY AND SANDY AND SANDY SILT AND SILTY OR CLAYEY FINE SAND WITH OCCASIONAL SMALL GRAVEL.	CL, SC	ML, SM	MARINE DEPOSITS OF TERTIARY OR UPPER CRETACEOUS PERIODS	
(T4)	MEDIUM COMPACT TO COMPACT GRAY AND GRAY-BROWN FINE TO MEDIUM SAND WITH SOME SILT AND SMALL GRAVEL CONTAINING LENSES OF DARK GRAY CLAY, OCCASIONALLY SLIGHTLY ORGANIC.	SM, SP	SM		(P4)	VERY COMPACT MOTTLED LIGHT GRAY, TAN, BUFF OR WHITE SILTY OR CLAYEY FINE TO MEDIUM SAND WITH SOME GRAVEL AND SCATTERED LIMONITE FRAGMENTS.	SM, SM	SP, GM	MARINE DEPOSITS OF TERTIARY OR UPPER CRETACEOUS PERIODS	
(T5)	COMPACT TO VERY COMPACT GRAY AND GRAY-BROWN FINE TO COARSE SAND WITH SOME GRAVEL AND SOME TO TRACE SILT, OR SAND AND GRAVEL WITH NUMEROUS BOULDERS.	SM, SN	SP, GM		(D)	HARD ORANGE-BROWN OR YELLOW-BROWN MICACEOUS FINE SANDY SILT OR VERY COMPACT LIGHT GRAY AND GREEN MICACEOUS SILTY FINE TO MEDIUM SAND, DECOMPOSED BEDROCK.	ML, SM	MH	WEATHERED IN SITU FROM SILTY FINE BEDROCK	
(Q1)	LOOSE TO MEDIUM COMPACT LIGHT BROWN SILTY OR CLAYEY FINE TO MEDIUM SAND WITH TRACE SMALL GRAVEL	SM, SC	SP	BRANDYwine FORMATION OF EARLY EOCENE OR PLEIOGENE TIMES	(MR)	MODERATELY TO HIGHLY WEATHERED AND JOINTED ROCK, REQUIRES RECOVERY GENERALLY LESS THAN 50%, CORE RECOVERY GENERALLY LESS THAN 70%.			ROCKS PALEOZOIC OR PRECAMBRIAN AGE	
(Q2)	LOOSE TO MEDIUM COMPACT LIGHT BROWN OR TAN SILTY OR CLAYEY FINE TO MEDIUM SAND WITH SOME SMALL GRAVEL.	SM, SC	SP		(R)	BEDROCK, PRIMARILY MISSISSIPPIAN SCHISTOSE GNEISS, IN SOME AREAS ALTERED BY INTRUSION, AND VARIOUS IGNEOUS ROCK IN-CLUDING GRANITE, DIORITE, AND GABBRO, WITH RECOVERY GENERALLY GREATER THAN 50%, CORE RECOVERY GENERALLY GREATER THAN 60%.			ROCKS PALEOZOIC OR PRECAMBRIAN AGE	

**TABLE 3-4:  
GENERALIZED STRATA  
DESCRIPTIONS**

This page intentionally blank.

## SECTION 02820

### FENCING

#### PART 1 - GENERAL

##### 1.01 DESCRIPTION:

- A. This section specifies providing chain-link fencing, gates and fan guards.
- B. Related Work Specified Elsewhere:
  - 1. Cast-in-place Structural Concrete: Section 03300.
  - 2. Grounding: Section 16060.

##### 1.02 SUBMITTALS:

- A. Submit the following for approval in accordance with the General Requirements and with the additional requirements as specified for each:
  - 1. Shop Drawings:
    - a. Manufacturer's product data and installation instructions for fence, posts, fabric, gates, hardware and accessories.
    - b. Site plan with fence showing locations of bracing, fan guards, gates, ground rods, depression closures and other special fence construction.
    - c. Details of gates, depression closures and other special construction showing fabrication and installation.
    - d. Details for installation of accessories.
  - 2. Samples:
    - a. Chain link fabric: One of each width and type, each 24 inches long.
    - b. Posts, railing, braces, gate frames: One of each size and type, each 24 inches long.
    - c. Truss rod and turnbuckle: One each.
    - d. Tension wire: One, 24 inches long.
    - e. Barbed wire: One, 24 inches long.
    - f. Tension bar: One, 24 inches long.
    - g. Gate corner assembly: One.
    - h. Fabric ties: Four each.
    - i. Rail and brace ends and post caps: Two each.
    - j. Barbed wire extension arms: One each.
    - k. Other materials and accessories: One each.
  - 3. Certification.

##### 1.03 QUALITY ASSURANCE:

- A. Codes, Regulations, Reference Standards and Specifications:
  - 1. Comply with codes and regulations of the jurisdictional authorities.
  - 2. AWS: D1.1.
  - 3. MS: MIL-P-21035.
  - 4. FS: FF-T-791, RR-F-191/2D, RR-F-191/3D, RR-F-191/4D.
  - 5. ASTM: A121, A392, A413/A413M-01, C1107/C1107M-07a, F668.



**1.04 JOB CONDITIONS:**

- A. Right of Access to Adjacent Private Property: As shown.

**PART 2 - PRODUCTS**

**2.01 MATERIALS:**

- A. Fabric:
  - 1. Steel, hot-dip galvanized after weaving, ASTM A392; Class 2 coating, two-inch mesh, No. 9 gauge wire, height shown, both top and bottom selvage twisted and barbed unless otherwise indicated on Contract Drawings. \*1
  - 2. PVC-coated steel: ASTM F668 Class 2b; two-inch mesh, 0.148-inch diameter zinc coated steel core wire, height as shown, black color PVC; top and bottom selvages twisted and barbed, unless otherwise shown on Contract Drawings.
  
- B. Posts, Top Rails and Braces:
  - 1. FS RR-F-191/3D, with the following additional requirements:
    - a. Posts: Class 1, Grade. Size in accordance with Table I unless otherwise shown.
    - b. Top rails: Class 1, Grade A; Size SP1.
    - c. Bracing: Class 1, Grade A; Size SP1.
    - d. Color coating: Where PVC-coated fabric is specified, provide matching PVC color ASTM F668 Class 2b coating.
  
- C. Accessories:
  - 1. FS RR-F-191/4D, with the following additional requirements:
    - a. Hot-dip galvanized, unless otherwise specified.
    - b. Wire ties:
      - 1) Fabric: No. 9-gauge steel.
      - 2) Tension wire: No. 11-gauge steel.
    - c. Tension wire: No 7-gauge Steel. \*1
    - d. Color coating: Where PVC-coated fabric is specified, provide matching PVC color ASTM F668 Class 2b coating.
  
- D. Barbed Wire:
  - 1. ASTM A121, Chain Link Fence Grade, 12-1/2 gauge steel wire with 14-gauge, four-point round barbs, five inches on center.
  
- E. Turnbuckle:
  - 1. FS FF-T-791, Type 1, Form 1, Class 8, Size 3/8 by six, hexagonal heads, UNC threads, hot-dip galvanized. Where PVC-coated fabric is required, provide matching PVC color coating thermally fused to the galvanized steel substrate.
  
- F. Latch:
  - 1. Plunger bar full height of gate, to engage stop at double gates.
  
- G. Security Chain:
  - 1. ASTM A413, Grade 43 High Test Chain, case-hardened carbon-steel, 3/8-inch diameter; hot-dipped galvanized at exterior locations.

- H. Padlock:
  - 1. WMATA Station areas - Corbin Russwin, Catalog No. PL5090 IC high security or equal. All keys are to be turned over to the Engineer or WMATA Representative.
    - a. Removable interchangeable core; with two keys, keyed and master-keyed as directed.
    - b. Body: Solid extruded brass.
    - c. Six-pin tumblers.
    - d. Shackle: Hardened steel, zinc-plated, 2-5/8 inch shackle length, ball bearing locking heel and toe.
  - 2. WMATA Track & Line chain-link fence gates areas - Master Lock #5KA, Key A389 with two keys. All keys are to be turned over to the Engineer or WMATA R Representative.
- I. Concrete: Section 03300, Class 3500, air-entrained
- J. Grout: Non-shrink, in accordance with ASTM C1107.
- K. High Zinc-Dust Content Paint: MS MIL-P-21035.

**2.02 SWING-TYPE GATES:**

- A. Provide swing-type gates, size as indicated on the Contract Drawings, complete with latches, stops (if required by the manufacturer), keepers, hinges and three strands of above the fabric (if shown on the Contract Drawings).
- B. Conform to Federal Specifications RR-F-191/2D, Single Swing Type I, Double Swing Type II, and as follows:
  - 1. Hot-dipped galvanized.
  - 2. Fabrication:
    - a. Fabricate gate perimeter frame from Class 1, Size SP2 pipe per Federal Standard RR-F-191/3D.
    - b. Fabric: Same fabric as used on the fence. Attach fabric securely to the gate frame at intervals not exceeding 15 inches.
    - c. Barbed wire: As specified in 2.1.D above.
    - d. Fan Guard: Materials and fabrication as specified for fencing.
  - 3. Hardware:
    - a. Hinges: Two or more galvanized steel or malleable iron, to suit the gate size: non-lift type, offset to permit 180 degrees opening.
    - b. Latch: Galvanized steel or malleable iron, combination type with provision for padlock.
    - c. Gate stops and center rest: Manufacturers' standard.

**2.03 CANTILEVERED SLIDE GATE:**

- A. Conform to Federal Specification RR-F-192/2D, Type III.
- B. Barbed Wire: As specified in 2.01 D. above.

## **PART 3 - EXECUTION**

### **3.01 FENCE INSTALLATION:**

- A. Perform necessary clearing, grubbing, excavation and filling to provide clear line-of-fence runs.
- B. Set posts in concrete footings, sized as shown. All end, corner, pull and intermediate posts are to be embedded a minimum of 3 foot below final grade. Footing depth shall be a minimum of 3 feet 6 inches.
- C. Extend concrete to two inches above ground line at posts and slope to drain away from posts. Form top 12 inches of footing, with remainder poured against excavated hole.
- D. Space posts at 10 feet maximum and eight feet minimum on centers. Place additional posts at each abrupt change in grade.
- E. Where rock is encountered, drill holes two inches deeper than depth shown and two inches greater than outside diameter of post. After post is placed, as shown, specified, and supported, fill remaining void with one-to-three grout mixture of cement and sand.
- F. Where fence is located on concrete structure, weld post to base plate, thickness and size as shown on Contract Drawings. Erect fence post truly vertical, where necessary using shims of approved alloy. Secure to structure with anchor bolts; number, diameter and length as shown on Contract Drawings. Fill void under base plate with non-shrink grout. Bolts, base plate and weld to be hot-dipped galvanized.
- G. Space pull posts at approximately 500-foot intervals for straight runs and at each vertical angle point. Install corner posts at each horizontal angle point. Provide corner, end and pull posts with horizontal braces and tie rods on each side of posts extending to and connecting to adjacent line posts.
- H. After posts are installed and grout has set, install top rail or tension wire and securely anchor at ends and to line posts before hanging fabric.
- I. Secure ends of fabric by tension bars threaded through loops in fabric and secured to posts by bands with bolts and nuts or other approved devices.
- J. Attach fabric outside framing system, away from Authority property. Stretch fabric by securing one end and applying sufficient tension by mechanical fence stretchers. Fasten fabric to line posts, tension wire and top railing with tie wires at spacing shown.
- K. Hold bottom of fabric as uniformly as possible to, but in no case to exceed, two inches above finished grade.
- L. Provide barbed wire where shown. Install support arms at 45 degrees upward and outward from Authority property; extend corner, gate and end posts as shown. Stretch barbed wire to remove kinks and sags and secure to bracket arms, using tension bands for attachment to posts.

- M. Install gates, gate stops and fan guards as shown.
- N. Set gate stops in concrete accurately so that plunger can be fully engaged.
- O. Furnish one chain with one padlock for each gate.
- P. Grounding: Section 16060.

### **3.02 GATE INSTALLATION**

- A. Install gates plumb, level and secure for full opening without interference. Install ground-set items in concrete for anchorage, as detailed on the Contract Drawings. Adjust the hardware for smooth operation and lubricate where necessary.
- B. Attach barbed wire as shown on the Contract Drawings.

### **3.03 DEFECTIVE WORK:**

- A. Remove and replace fencing which is improperly located and is not true to line and grade, and posts which are not plumb.
- B. Repair damaged galvanizing by thoroughly wire brushing damaged area to remove loose and cracked zinc coating, and paint with two coats of high zinc-dust content paint. Allow first coat to dry thoroughly before applying second coat.

## **PART 4 -MEASUREMENT AND PAYMENT**

### **4.01 MEASUREMENT**

- A. Measurement of work specified in this Section will be made in the following manner:
  - 1. No separate measurement.

### **4.02 PAYMENT**

- A. Compensation for work specified in this Section will be made in the following manner:
  - 1. Included in the price of the work of which it is a part.

**SEE ENDNOTES BELOW. THEY ARE AN ESSENTIAL PART OF THIS SECTION UNTIL EDITED BY SECTION DESIGNER.**

### **ENDNOTES**

**\*1.** Please verify that Standard Drawings conform to the revised Specifications for Section 02820; particularly that Utility Standard Drawing ST-U-34 contains Note 8 stating that fabric on Type A & A-1 fences less than 72 inches high have both top & bottom selvages knuckled, and that Note 8 is referenced on applicable section of CHART; and contains notes to Details 2 & 3 indicating maximum height of bottom tension wire above grade is 6 inches.

**END OF SECTION**

1X0000 (11/07)

02820-50

This page intentionally blank.

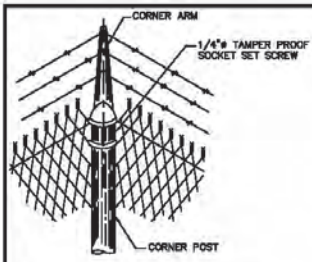

CORNER POST AND ARM FOR TYPE B FENCE  
DETAIL 1

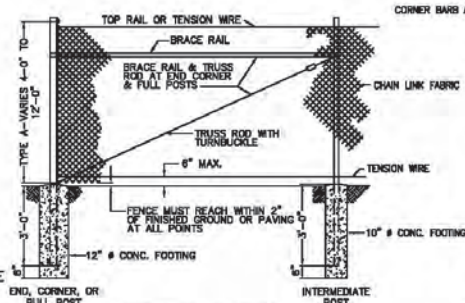

TYPE A & A1 FENCE  
DETAIL 2

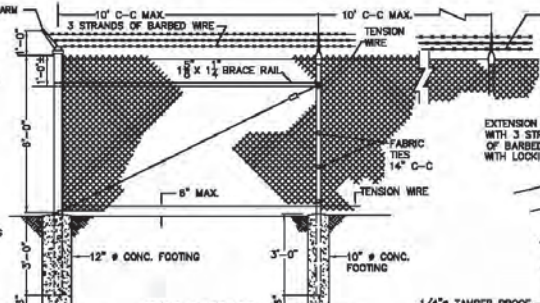

TYPE B FENCE  
DETAIL 3

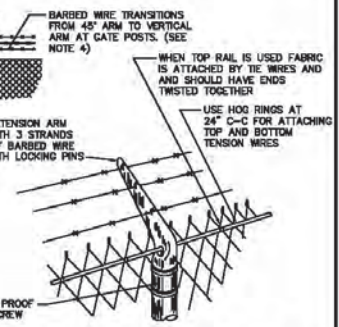

TYPE B INTERMEDIATE POST TOP  
DETAIL 7

CHART					
TYPE	FENCE HEIGHT	TOP LINE	BOTTOM LINE	SELVAGE	REFERENCE
A	4' TO 12'	TENSION WIRE	TENSION WIRE	TOP TWISTED & BARBED TOP & BOTTOM KNUCKLED	DETAIL 2
A-1	4' TO 12'	TOP RAIL	TENSION WIRE	TOP TWISTED & BARBED TOP & BOTTOM KNUCKLED	DETAIL 2
B	6" WITH BARBED WIRE	TENSION WIRE	TENSION WIRE	TOP TWISTED & BARBED TOP & BOTTOM KNUCKLED	DETAIL 3

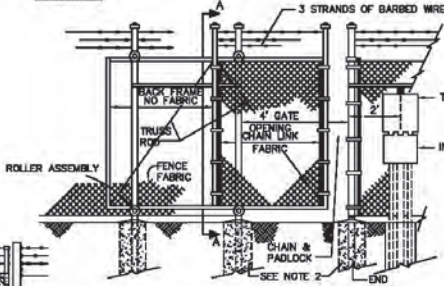

SLIDING GATE - ELEVATION  
(VIEW FROM WITHIN METRO PROPERTY)

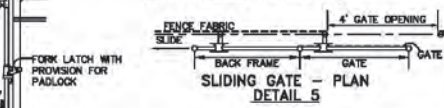

SLIDING GATE - PLAN  
DETAIL 5

- NOTES
- GATE FABRIC SHALL BE KNUCKLED ON TOP SELVAGES
  - SIZE OF CONCRETE FOUNDATIONS AT GATES, AS RECOMMENDED BY THE GATE MANUFACTURER
  - FENCE, GATE POSTS, AND FRAMES SHALL BE GROUND IN ACCORDANCE WITH WMATA STANDARD SPECIFICATION No. 18080
  - WHEN 3-STRAND BARBED WIRE IS TO BE ADDED TO TOP OF FENCE, POST EXTENSIONS AND BARBED WIRE ARMS ON THE GATE SHALL BE VERTICAL
  - DETAILS OF THE SELECTED FENCE POSTS, GATES AND ACCESSORIES MAY NOT AGREE WITH THIS DRAWING BUT MUST CONFORM TO FS RR-F-191
  - POSTS, RAILS AND RODS TO BE INSTALLED INSIDE FENCE FABRIC

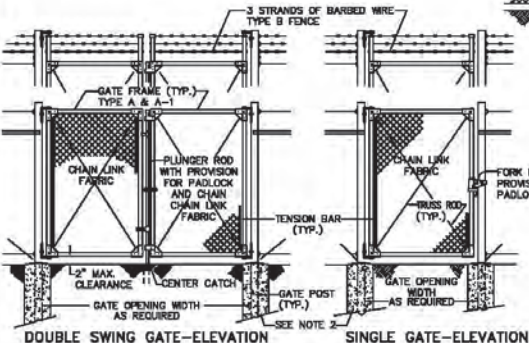

DOUBLE SWING GATE-ELEVATION

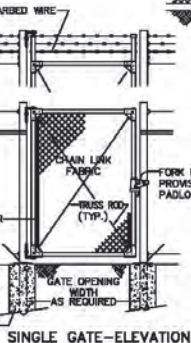

SINGLE GATE-ELEVATION

SWINGING GATES  
DETAIL 4

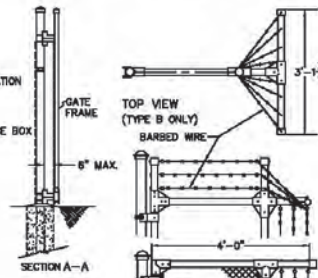

FAN GUARD - TYPE A, A-1 & B FENCE  
DETAIL 6

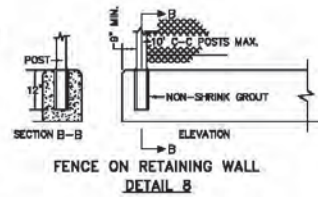

FENCE ON RETAINING WALL  
DETAIL 8

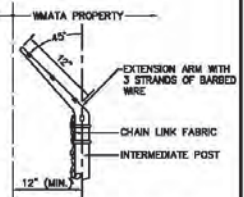

TYPICAL LOCATION OF TYPE 'B' FENCE  
ALONG WMATA PROPERTY  
DETAIL 9

DESIGNED AS PER	NUMBER	REFERENCE DRAWINGS		REVISIONS	
		DATE	DESCRIPTION	DATE	DESCRIPTION
1-8-78				09/2007	ENHANCED AND ISSUED BY THE AUTHORITY
DRAWN					
CHECKED					
APPROVED AS SHOWN					

WASHINGTON METROPOLITAN AREA TRANSIT AUTHORITY	
OFFICE OF ENGINEERING SUPPORT SERVICES	
SUBMITTED	10/2007
DATE	DATE
APPROVED	10/2007
DATE	DATE

CIVIL STANDARD DRAWING FENCE DETAILS	
SCALE	DWGNG NO.
NOT TO SCALE	ST-C-034

This page intentionally blank.

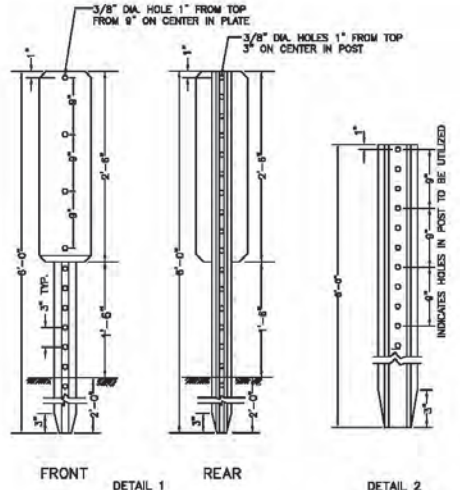

DETAIL 1  
ELEVATION  
SCALE 1 1/2"=1"

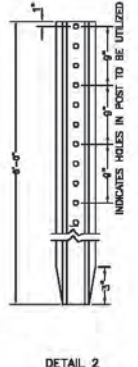

DETAIL 2  
MARKER POST  
NO SCALE

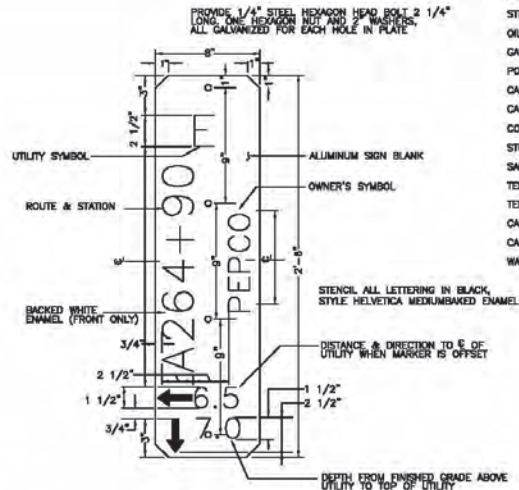

DETAIL 3  
TARGET PLATE LAYOUT  
SCALE 3"=1"

UTILITY	SYMBOL	OWNER	SYMBOL
STEAM TUNNEL	ST	DISTRICT OF COLUMBIA	DC
STEAM LINE	S	CHESAPEAKE & POTOMAC TELEPHONE COMPANY	C & P
OIL OR GASOLINE LINES	F	POTOMAC ELECTRIC POWER COMPANY	PEPCO
GAS LINE	G	VIRGINIA POWER CO.	VEPCO
POWER LINE	E	WASHINGTON SUBURBAN SANITARY COMMISSION	WSSC
CABLE - STREET LIGHT	CS	ARLINGTON COUNTY	ARL CO.
CABLE - TRAFFIC LIGHT	CT	FAIRFAX COUNTY	FX CO.
COMBINED SYSTEM SEWER	SC	FAIRFAX COUNTY WATER AUTHORITY	FCWA
STORM SEWER OR CULVERT	SS	ALEXANDRIA	ALEX
SANITARY SEWER	SAN	FALLS CHURCH	FA CH
TELEPHONE LINE	T	MARYLAND-NATIONAL CAPITAL PARK AND PLANNING COMMISSION	M-NDPPC
TELEGRAPH LINE	TE	PENTAGON	PENT
CABLE - FIRE ALARM	CF	VIRGINIA DEPT. OF TRANSPORTATION	VDOT
CABLE - POLICE	CP	MONTGOMERY COUNTY	MONT CO.
WATER MAIN	W	PRINCE GEORGE'S COUNTY	PGCO
		CITY OF ROCKVILLE	ROCK
		MARYLAND STATE HIGHWAY ADMINISTRATION	MSHA
		WASHINGTON GAS LIGHT COMPANY	WGLCo
		BALTIMORE GAS & ELECTRIC	BGE
		WESTERN UNION	WU
		PLANTATION PIPE LINE	PPL
		GENERAL SERVICES ADMINISTRATION	GSA
		COLONIAL PIPE LINE	CPL
		WASHINGTON METROPOLITAN AREA TRANSIT AUTHORITY	WMATA
		TRANSCONTINENTAL GAS PIPE LINE CORP.	TRANSCO

- NOTES:
- UTILITY MARKERS SHALL BE PROVIDED TO INDICATE UNDERGROUND UTILITY LINES WHICH CROSS AT-GRADE AND EMBANKMENT SECTIONS OF THE METRO RIGHT-OF-WAY (ROW); EXCEPT METRO OWNED FACILITIES WHICH ARE PARALLEL WITH OR ENTIRELY WITHIN THE ROW, OR OTHER CROSSINGS HAVING VISIBLE MANHOLES, INLETS, OR OTHER UTILITY STRUCTURES
  - MARKERS SHALL BE AS SHOWN ON THIS SHEET WITH STATIONING TO THE NEAREST FOOT.
  - ALL LETTERS SHALL BE HELVETICA MEDIUM.
  - MARKERS SHALL BE PLACED AS SHOWN IN DETAIL 4 WITH TARGETS FACING AND PARALLEL WITH ADJACENT METRO TRACKS. TWO MARKERS ARE REQUIRED FOR EACH STEEL POST SO MARKER IS VISIBLE FROM INSIDE WMATA'S RIGHT-OF-WAY AND OUTSIDE FENCE.
  - WHEN CIRCUMSTANCES PROHIBIT PLACING MARKER ON CENTERLINE OF UTILITY IT SHALL BE LOCATED AS CLOSE AS PRACTICABLE TO THE CENTERLINE OF UTILITY. THE DIRECTION OF UTILITY SHALL BE INDICATED BY A HORIZONTAL ARROW AND THE AMOUNT OF OFFSET TO THE NEAREST 0.5' AS SHOWN BY DETAIL 3.
  - DEPTH FROM SURFACE TO TOP OF UTILITY OR ITS CASEMENT PIPE SHALL BE TO NEAREST 0.5' AND SO INDICATED ON MARKER TARGET.

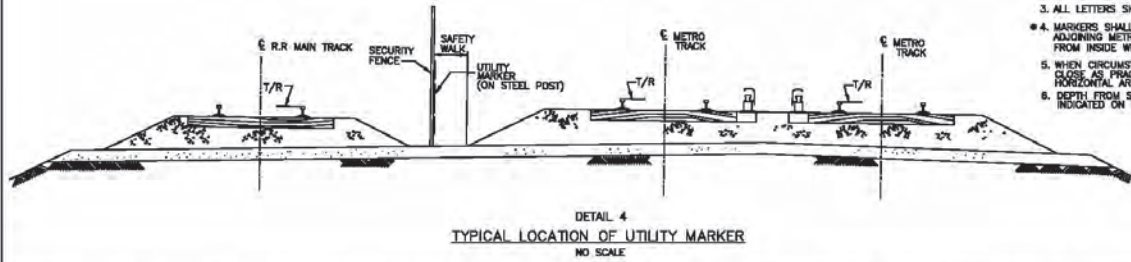

DETAIL 4  
TYPICAL LOCATION OF UTILITY MARKER  
NO SCALE

DESIGNED	C.A. PRESS	7-3-02	REFERENCE DRAWINGS		REVISIONS	
			NUMBER	DESCRIPTION	DATE	BY
DRAWN	CM / RB	7-10-04			04/2007/MSA	REMOVED AND ISSUED BY THE AUTHORITY
CHECKED	A. RIVER	10-8-04			07/2007/SPF	UPDATED NOTE 4 &
APPROVED	JAMES	10-8-04				

WASHINGTON METROPOLITAN AREA TRANSIT AUTHORITY  
OFFICE OF ENGINEERING SUPPORT SERVICES

SUBMITTED: *MSA/SPF* 10/2007 DATE  
APPROVED: *[Signature]* 10/2007 DATE

UTILITY STANDARD DRAWING  
AT GRADE STANDARD UTILITIES MARKERS

SCALE: NOT TO SCALE DRAWING NO. ST-U-066



This page intentionally blank.

## **Appendix 4 - Monitoring, Instrumentation & Contingency Plans**

**[Plate B-1: Location of Monitoring Points](#)**

**[Sample - Instrumentation details including accuracy](#)**

**[Monitoring Plan Instrumentation Checklist](#)**

**[Metrorail System Design Datums](#)**

**[Sample - Movement Detection Report Cover Sheet](#)**

**[Sample - Movement Detection Report Summary](#)**

This page intentionally blank.

### PLATE B-1

POSSIBLE LOCATIONS OF MONITORING POINTS. RECORD BOTH VERTICAL (Y AXIS) AND HORIZONTAL (X AXIS) MOVEMENT OF EACH POINT.

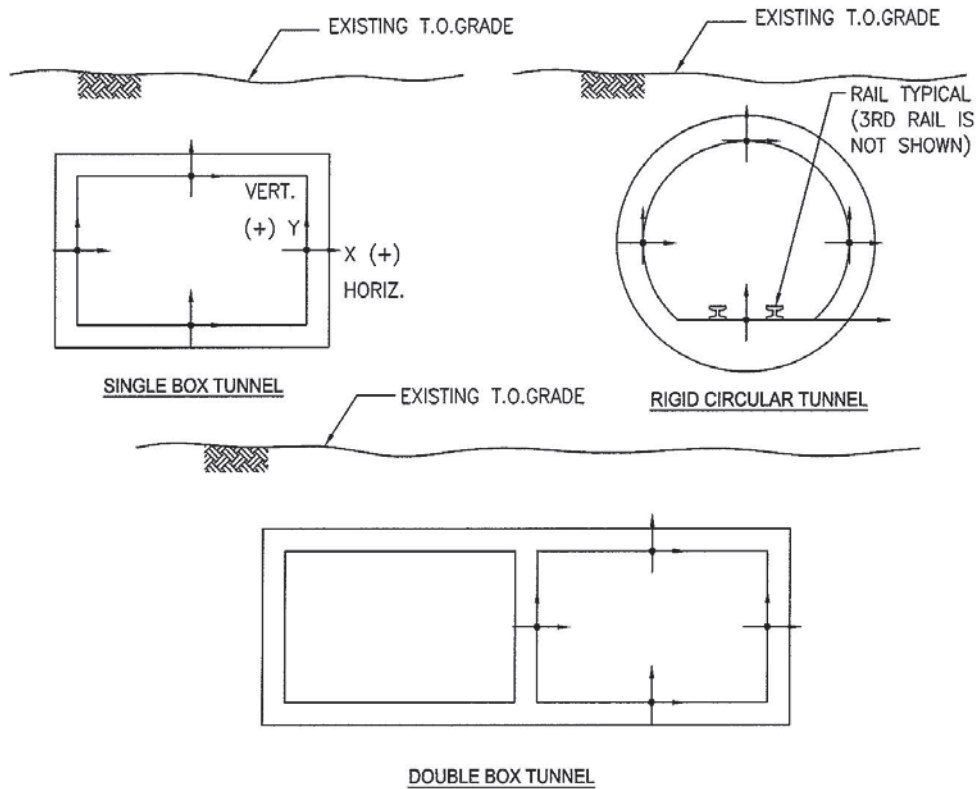

THE CASES SHOWN HERE ARE FOR GUIDANCE IN PREPARING THE MONITORING PLAN. SOME ADJUSTMENTS MAY BE NECESSARY BASED ON SPECIFIC STRUCTURE AND LOCATION. FOR OTHER STRUCTURES ALSO USE THESE CASES AS GUIDANCE.

X AND Y INDICATE THE DIRECTION OF THE MOVEMENTS OF POINTS ON STRUCTURE.

### LOCATION OF MONITORING POINTS

WMATA ENGINEERING STANDARDS

## Sample Instrumentation details and accuracy

# LEICA TCA1800 • TCA2003 • TC2003

### Technical specifications

#### Models and options

	TCA1800	TCA2003	TC2003
Angle measurement	•	•	•
Distance measurement (IR)	•	•	•
Motorized	•	•	•
Automatic target recognition (ATR)	•	•	•
Guide light (EGL)	○	○	○
Remote control RCS1100	○	○	○

• Standard ○ Optional



#### Angle measurement

		TCA1800	TCA2003	TC2003
<b>Accuracy</b> (standard deviation, ISO 17123-3)	Hz, V	1" (0.3 mgon)	0.5" (0.15 mgon)	0.5" (0.15 mgon)
	Display resolution	1" (0.1 mgon)	0.1" (0.01 mgon)	0.1" (0.01 mgon)
<b>Compensator</b>	Method:		absolute, continuous, diametrical	
	Working range:	4' (0.07 gon)	4' (0.07 gon)	4' (0.07 gon)
	Setting accuracy:	0.3" (0.1 mgon)	0.3" (0.1 mgon)	0.3" (0.1 mgon)
	Method:		electronic dual axis compensator	



#### Distance measurement (IR)

<b>Range</b> (average atmospheric conditions)	Round prism (GPR1):		2500 m	
	360° reflector (GRZ4):		1300 m	
	Mini prism (GMP101):		900 m	
	Reflective tape (60 mm x 60 mm)		200 m	
<b>Accuracy / measurement time</b> (standard deviation, ISO 17123-4)	Standard mode:	1 mm + 2 ppm / 3.0 s	1 mm + 1 ppm / 3.0 s	1 mm + 1 ppm / 3.0s
	Fast mode:		3 mm + 2 ppm / 1.5 s	
	Tracking mode:		5 mm + 2 ppm / 0.3 s	
	Display resolution:	0.1 mm	0.01 mm	0.01 mm
	Method:		Phase measurement (coaxial, invisible infrared laser)	



#### Guide light (EGL)

<b>Range</b> (average atmospheric conditions)	Working range:	5 m - 150 m
<b>Accuracy</b>	Positioning accuracy:	5 cm at 100 m



#### Motorized

Maximum speed	Rotating speed:	45° / s
---------------	-----------------	---------



#### Automatic target recognition (ATR)

<b>Range ATR mode / LOCK mode</b> (average atmospheric conditions)	Round prism (GPR1):	1000 m / 500 m
	360° reflector (GRZ4):	500 m / 350 m
	Shortest measurable distance:	5 m
<b>Accuracy / measurement time</b>	Up to 200 m: 1 mm, > 200 m: as per angle measuring accuracy +1 mm / 3-4 s	
	Tangential (standard mode):	5 m / s at 100 m, 1 m / s at 20 m
<b>Max. speed (LOCK-Modus)</b>	Tangential (with EDM tracking mode):	1 m / s at 100 m, 0.2 m / s at 20 m
	Method:	Digital image processing (laser beam)



#### General data

<b>Telescope</b>	Magnification:	30x	<b>Laser plummet</b>	Centring accuracy:	1.0 mm at 1.5 m	
	Free objective aperture:	42 mm		Laser dot diameter:	2.5 mm at 1.5 m	
	Field of view:	1°33' (1.72 gon) / 2.7 m at 100 m		<b>Endless drives</b>	Number of drives:	2 horiz. / 1 vert. (TCA), 1 horiz. / 1 vert. (TC)
	Focussing range:	1.7 m to infinity			<b>Battery (GEB187)</b>	Type:
	<b>Keyboard and display</b>	Display:		64*210 pixels, graphic LCD, with illumination		Voltage:
		Keyboard:		32 keys (6 function keys, 12 alphanumeric keys, 6 direct keys)	Capacity:	1.8 Ah
	Angle display:	360° °, 360° decimal, 400 gon, 6400 mil		<b>Weight</b>	Operating time:	TCA 400, TC 600 distance measurements
	Distance display:	meter, int. ft, int. ft/inch, US ft			Instrument:	7.5 kg
	Position:	keyboard in position I and II (standard)			Battery:	0.3 kg
	<b>Data storage</b>	Internal memory:		S-RAM card (512 KB and 2 MB)	Tribrach:	0.9 kg
Number of data records:		~4000 per MB	<b>Working environment</b>	Working temperature:	-20°C to +50°C	
Interface:	RS232	Storage temperature:		-40°C to +70°C		
<b>Circular bubble</b>	Sensitivity:	4' / 2 mm		Dust / water (IEC 60529):	IP54	
			Humidity:	95%, non-condensing		

## Monitoring Plan Instrumentation Checklist

Total station instrument type (circle one):      conventional total station      robotic total station

Total station manufacturer and model: \_\_\_\_\_

Instrument angle accuracy (circle one):      .5"      1"      2"      3"

Instrument EDM accuracy (circle one):      1 mm    2 mm    3 mm    (fill in) ppm +/- \_\_\_\_\_

Dual compensator (circle one):      yes      no

Instrument and tribrach centering accuracy (circle one):      1 mm      2 mm      3 mm

Instrument location (circle one):      forced centered platform      tripod

Monitoring prism type  
(circle all that apply):

stick on target	model # _____
mini 360	model # _____
full size 360	model # _____
mini circular	model # _____
full size circular	model # _____

Level instrument type (circle one):      automatic level      digital level

Level instrument manufacturer and model: \_\_\_\_\_

Level rod type (circle all that apply):

invar without struts	model # _____
invar without struts	model # _____
semi-precise single piece	model # _____
semi-precise sectional	model # _____
semi-precise folding	model # _____

Description of other monitoring equipment:

---

---

---

---

---

---

---

---

# Metrail System Design Datums

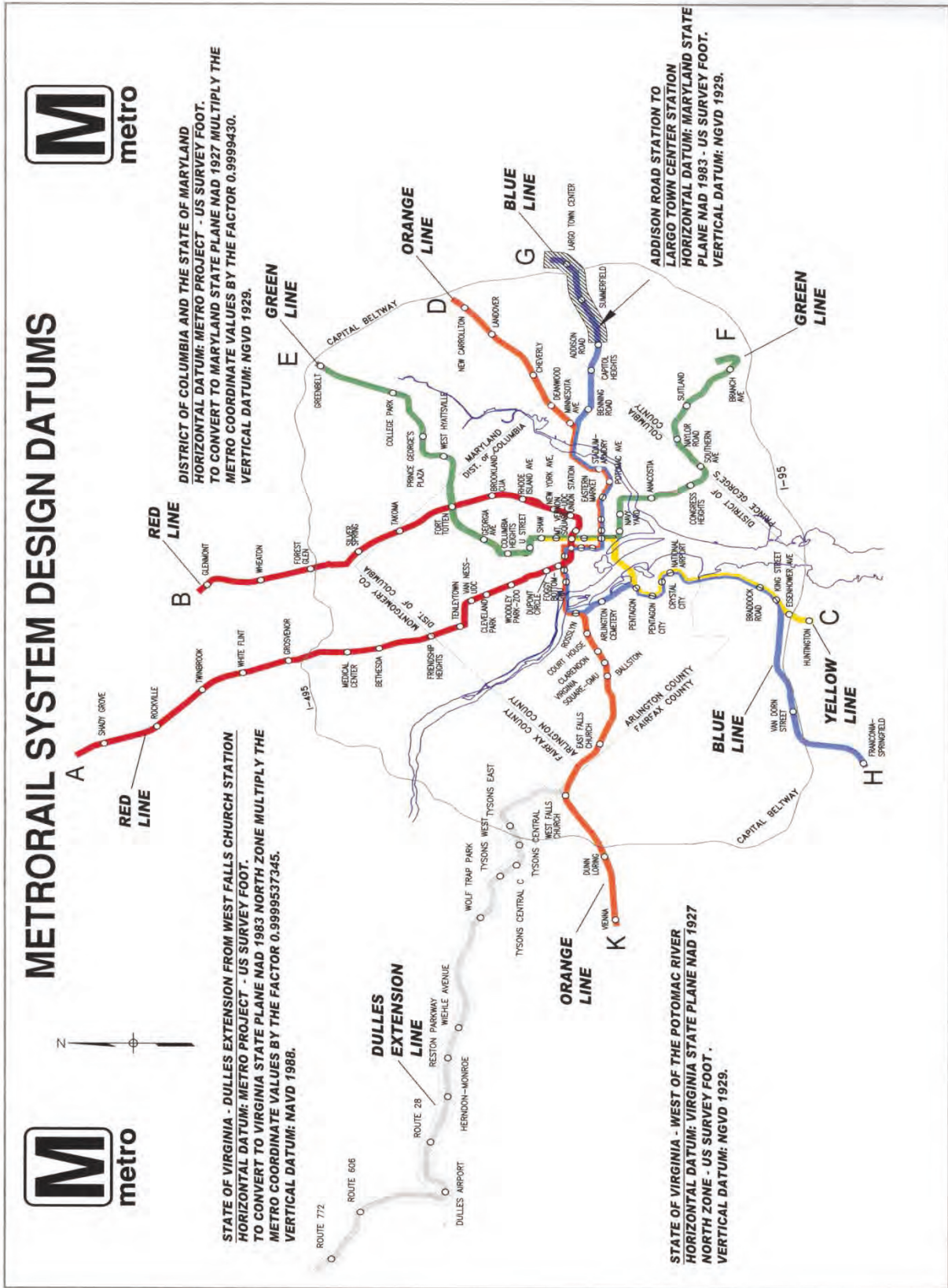

## Sample Movement Detection Report Cover Sheet

Title: "SESSION 29" Movement Detection Survey of a Line (Shady Grove Route) Abutment A4027, Piers A4035, A4045, A4055, Girders Ar4031, Al4031 and Ground Monitoring Points

WMATA adjacent construction contract (name) WSSC water tunnel under A line at Station 521+25 and (contract number) 254178.

This movement detection survey is being performed by "DEF Survey Firm" on behalf of the WSSC. Technical questions about this report can be directed to:

Mr. Professional  
[Professional@DEF.com](mailto:Professional@DEF.com)  
Office 202-894-1234  
Fax 202-894-4321  
DEF Survey Firm  
125 Main St.  
Washington, DC 20001

"Session 29" movement detection survey was performed on 11/04/08 at 8 AM and the next scheduled observation date is 11/07/08 at 8 AM.

All optical and robotic survey instrument observations were performed by Mr. BP Point and Ms. Accurate. Geotechnical instrument readings were obtained by remote communication link to the DEF Survey Firm office by Ms. Geotech.

Please note, ground monitoring point GMP-3 shows the greatest observed horizontal movement of 0.5". GMP-3 is on the east side of the WMATA track embankment and was installed 1/28/08. Another ground monitoring point, GMP-1 located on the west side the WMATA track embankment shows horizontal movement of 0.4".

One other ground monitoring point PMP-4 located on the north (CSX) side of the WMATA track embankment that was installed on 8/6/08 is also showing horizontal movement of 0.4". If the movement observed on PMP-4 continues at its present rate, then predicted movement of approximately X.X" might be expected over a X month period.

Additional movement at abutment monitoring points MP-7 and MP-8 is noted since Session 28 observations were made on 10/23/08.

Please note - 3.5 inches of rain fall was recorded at a nearby weather station on 10/25/08.

A graphical representation showing direction and magnitude of observed movement of all monitoring points to date is shown as .....page 2 of 17

Spreadsheets showing results of all monitoring sessions 1 through 29 are shown as ..... pages 3-16 of 17

Survey instrument accuracy, equipment description and procedures used for this survey is provided as ..... page 17 of 17



**Sample Movement Detection Report Summary** of survey instrument and accuracy, survey and or geotechnical equipment description, and survey procedures

Survey Instrument and Accuracy:

Since 27-Dec-2007 a Leica TPS1200 PLUS (SN:238826) robotic instrument was used which has a horizontal and vertical angle measurement accuracy of 1" standard deviation ISO 17123-3 and an EDM accuracy of 1mm + 1.5 ppm standard deviation ISO 17123-4.

Survey Equipment Description:

LEICA TPS1201 PLUS is a robotic total station which consists of precision angle measurement systems that provide instant horizontal and vertical circle readings. The instrument automatically corrects for any out of level condition by use of a centrally located twin-axis compensator. This instrument has a coaxial EDM and uses an infrared laser to measure distances to monitoring prisms.

All prisms used in this survey are permanently mounted Leica GMP104 L-Bar Monitoring Mini Prism, Part No: 641762. The GMP104 Mini Prism is fixed in a metal housing providing a precise monitoring target.

---

Survey Procedures:

The survey instrument is set on a permanently mounted forced centered bracket (point P1) outside the ZOI. The instrument is run through an on-board collimation check prior to starting the observations. The instrument is initialized in its robotic mode and performs a backsight check on three permanently mounted mini prisms which are also outside the ZOI (points BA1, BA2 and BA3).

The HI of the instrument is established by "bucking in" a Leica NA-2 automatic differential level into the vertical axis of the robotic instrument as marked on the side of the instrument by the manufacturer. Differential elevations are transferred from a known WMATA benchmark (A-652) located outside the ZOI.

Once a backsight check is performed, the instrument begins making observations to all movement detection mini prisms which are also permanently mounted. Observations consist of 8 sets of direct and reverse angle and distance measurements to each of the foresight prisms. The data from these observations are reduced to one mean horizontal and vertical angle and slope distance per foresight point and is then used to compute a north and east coordinate with elevation. The coordinate from the current observation is compared with the initial coordinate observation to compute the difference and is then organized in the accompanying report.

## **Appendix 5 - Safety Requirements & Compliance**

**Click on the link to obtain the following documents:**

[http://www.wmata.com/business/joint\\_development\\_opportunities/adjacent\\_construction\\_information.cfm](http://www.wmata.com/business/joint_development_opportunities/adjacent_construction_information.cfm)

**Workflow: Support Request and Daily Support Tracking Form**

**Site Specific Work Plan (SSWP) Template**

**JDAC Support Request (JSR) Form**

**JDAC Daily Support Tracking Form**

This page intentionally blank.

## **Appendix 6 - Real Estate, Insurance & Design Criteria Section 9 – Right-of-Way**

**[WMATA's Indemnification and Insurance Requirements in Real Estate Permits](#)**

**[WMATA Design Criteria Section 9 - Right-of-Way](#)**

**Click on the link to obtain the following documents:**

**[http://www.wmata.com/business/joint\\_development\\_opportunities/adjacent\\_construction\\_information.cfm](http://www.wmata.com/business/joint_development_opportunities/adjacent_construction_information.cfm)**

**Real Estate Permit Application**

This page intentionally blank.

**WMATA'S INDEMNIFICATION AND INSURANCE REQUIREMENTS  
IN  
REAL ESTATE PERMITS**

WMATA reserves the right to make any changes it deems appropriate to the following indemnification and insurance requirements.

**Defined Terms**

**Permit** is the written legal agreement which allows entry onto WMATA property (Permitted Premises).

**Permitted Premises** is the WMATA property which is the subject of the Permit.

**Permitted Parties** are those individuals and entities entering upon the Permitted Premises to do work for the Permittee in accordance with the terms of the Permit.

**Permittee** is the Owner/Developer/Contractor/Consultant (ODC) or any combination thereof.

**Indemnification**

- A.** Permittee shall, and Permittee shall contractually require all other Permitted Parties to, indemnify, defend and hold harmless WMATA, its directors, officers, employees and agents from any and all claims, actions, proceedings, liabilities, losses, demands, damages, obligations, penalties, costs, charges and expenses, including, but not limited to, reasonable attorney's fees, of whatsoever kind and nature for injury, including personal injury or death of any person or persons, including employees of Permittee or any other Permitted Party, and for loss or damage to any property, occurring in connection with, or in any way arising out of the use, occupancy and performance of the work authorized by this Permit or related to this Permit or the Project, and/or any acts in connection with activities to be performed under this Permit resulting in whole or in part from the acts, errors or omissions of Permittee or any other Permitted Party, or any employee, agent or representative of Permittee or any other Permitted Party. Nothing in the preceding sentence shall be deemed to relieve Permittee from ultimate liability for any obligation of Permittee under this Permit.
- B.** Permittee shall, and Permittee shall contractually require all other Permitted Parties to, indemnify, defend and hold harmless WMATA, its directors, officers, employees and agents from all claims, actions, proceedings, liabilities, losses, demands, damages, penalties, costs, charges, remedial costs, environmental claims, fees or other expenses including attorney's fees, related to, arising from or attributable to any effluent or other hazardous waste or substance, toxic waste or substance, contaminant, pollutant, petroleum or petroleum-based product, asbestos, residue, contaminated soil or other similar material discharged from, removed from, or introduced on, about or under the Permitted Premises by Permitted Parties or anyone acting on their behalf.
- C.** If any claim, demand, action or proceeding relating to the indemnification required by this Section 21 is brought against WMATA, then upon written notice from WMATA to

Permittee, Permittee shall, at Permittee's expense, resist or defend such action or proceeding by counsel approved by WMATA in writing, such approval not to be unreasonably withheld, but no approval of counsel shall be required where the cause of action is resisted or defended by counsel of any insurance carrier obligated to resist or defend the same. WMATA reserves the right to use its own counsel under this indemnity at Permittee's sole cost and expense. Permittee shall be jointly and severally liable with any Contractor directly responsible for any claim, demand, action, proceeding, liability, loss, damage, obligation, penalty, cost, charge or expense arising under this Permit, and nothing in this Permit shall be deemed to relieve Permittee from ultimate liability for any obligation of Permittee under this Permit.

- D.** Permittee understands and agrees that it is Permittee's and all other Permitted Parties' responsibility to provide indemnification to WMATA pursuant to this Section 21. The provision of insurance, while anticipated to provide a funding source for this indemnification, is in addition to any indemnification requirements and the failure of insurance to fully fund any indemnification shall not relieve Permittee and other Permitted Parties of any obligation assumed under this indemnification.

### **Insurance**

The following outlines the minimum insurance requirements, minimum insurance coverages, and minimum limits of insurance for those coverages that Permittee will be required to purchase and maintain as a means to gain access to WMATA property and/or perform work adjacent to WMATA property:

- A.** Permittee is required to maintain the insurance coverage(s) outlined herein through the completion of all construction and/or any activities in which Permittee may potentially need access to WMATA properties or is within WMATA's Zone of Influence.
- B.** The insurance coverage requirements and limits of insurance for those coverages outlined herein are minimum coverage and limits. Permittee is encouraged, at its sole cost and expense, to purchase any additional insurance coverages and or limits of insurance that Permittee deems prudent and necessary to manage Permittee's risk.
- C.** Upon written request from WMATA, Permittee shall provide copies of any and all policy(s), including all endorsement(s), within five (5) business days of such request.
- D.** Receipt, review and communications regarding Certificates of Insurance, insurance policy(s), endorsements or other vehicles utilized to document compliance with these minimum insurance requirements does not constitute acceptance by WMATA.
- E.** Insurance policies must be written on admitted paper, unless otherwise indicated herein or agreed to in writing by WMATA, with an insurance company reasonably acceptable to WMATA.
- F.** Unless otherwise noted, "claims made" insurance policies are not acceptable.

- G. Any insurance policy utilizing a self-insured retention (SIR) requires approval from WMATA.
- H. Permittee is required to incorporate these minimum insurance requirements into contract requirements of all subcontractors of every tier.
- I. Compliance with these minimum insurance requirements does not relieve Permittees from their respective liability to WMATA should their liability exceed the minimum insurance limits, or minimum coverage requirements outlined herein.

**Workers' Compensation and Employer's Liability Required Minimum Limits of Coverage:**

Workers' Compensation	Statutory	
Employers' Liability	\$1,000,000	Each Accident
	\$1,000,000	Disease Policy Limit
	\$1,000,000	Disease Each Employee

**Required Minimum Coverage(s):**

1. Workers' Compensation statutory coverage must be provided on "all states" basis.
2. Permittee and subcontractors of any tier performing work within 500 feet of navigable water must have their Workers' Compensation policy endorsed to provide coverage for both Jones Act Liability and Longshore and Harbor Workers' Compensation Act Liability.

**Commercial General Liability Required Minimum Limits of Coverage:**

Permittee and its Contractor(s): **[TBD by WMATA's Office of RISK]**

\$X,XXX,XXX	Each Occurrence Limit
\$X,XXX,XXX	General Aggregate Limit
\$X,XXX,XXX	Products and Completed Operations Limit

**Required Minimum Limits of Coverage: Subcontractors of every tier:**

\$X,XXX,XXX	Each Occurrence Limit
\$X,XXX,XXX	General Aggregate Limit
\$X,XXX,XXX	Products and Completed Operations Limit

**Required Minimum Coverage(s) All Permittees:**

1. Commercial General Liability (CGL) coverage form shall be ISO Occurrence Form CG0001 (12/04) or its equivalent. Equivalency determination shall be made in WMATA's sole and unreviewable discretion.
2. Required minimum limits of coverage may be achieved through a



combination of the aforementioned CGL coverage form and umbrella excess liability coverage form(s), provided that the umbrella excess liability coverage form(s) provide the same or broader coverage than the prescribed CGL coverage form.

3. Policy shall be endorsed with Additional Insured Endorsement(s) in compliance with the Additional Insured Section 22.8 of this Permit. Commercial General Liability and Umbrella Excess Liability forms must provide defense coverage for additional insureds.
4. Policy shall be endorsed with a Waiver of Subrogation Endorsement(s) in compliance with the Waiver of Subrogation Section 22.9 of these minimum insurance requirements.
5. The definition of “insured contract” shall be modified to provide coverage for contractual liability for contracts for construction, demolition or any other operations that are within 50 feet of a railroad and sidetrack agreements.
6. Defense costs (allocated loss adjustment expense) must be included and in excess of the policy limits for all primary and umbrella excess policies.
7. Policy shall be endorsed with ISO endorsement CG 25 03 03 97; “Designated Construction Project(s) General Aggregate Limit”, and designate “any and all construction projects” as the designated construction project. This Section 22.3.7 applies only to the primary CGL policy.

**Railroad Protective Liability Insurance (RRPL):**

For work within 50 feet of WMATA railroad tracks or work within WMATA rail stations, Railroad Protective Liability Insurance is required with the following minimum limits of coverage: **TBD by WMATA’s Office of RISK]**

<b>\$X,XXX,XXX</b>	Each Occurrence Limit
<b>\$X,XXX,XXX</b>	Aggregate Limit

**Required Minimum Coverage(s):**

1. Railroad Protective Liability (RRPL) policy on a policy form that is acceptable to WMATA, issued by an insurance company that is acceptable to WMATA.
2. WMATA shall be the first named insured.

3. Cost of RRPL shall be the sole responsibility of Permittee or a Permittee appointed entity.
4. The “wet ink” original RRPL policy shall be sent to WMATA at the following address:
 

Washington Metropolitan Area Transit Authority  
Office of Risk Management, Room 8F  
600 Fifth Street, NW  
Washington, DC 20001.
5. WMATA Blanket RRPL Program Option: WMATA may offer to waive the requirement for Permittee to procure a standalone RRPL insurance policy if: (1) the work can be covered under WMATA’s blanket RRPL program; and (2) Permittee prepays the premium which shall be determined by the rate schedule promulgated by WMATA’s insurer in effect as of the Effective Date of this Permit. Permitted Parties shall be advised of and pay the applicable premium or procure a standalone RRPL policy on WMATA’s behalf.

**Business Auto Liability Required Minimum Limits of Coverage:**  
**[TBD by WMATA’s Office of RISK]**

<b>\$X,XXX,XXX</b>	Combined Single Limit
--------------------	-----------------------

**Required Minimum Coverage(s):**

1. Business Auto Liability shall be written on ISO Business Auto Coverage Form CA 00 01 03 06, or its equivalent. Equivalency determination shall be made in WMATA’s sole and unreviewable discretion.
2. Policy shall be endorsed with Additional Insured Endorsement(s) in compliance with the Additional Insured Section 22.8 of this Permit.
3. Policy shall be endorsed with a Waiver of Subrogation Endorsement(s) in compliance with the Waiver of Subrogation Section 22.9 of this Permit.
4. Business Auto Liability Minimum Combined Single Limit requirements may be obtained through the combination of a primary business auto liability policy and an umbrella excess liability policy provided that the umbrella excess liability policy complies with items 22.5.1 through 22.5.3 above.

**Professional Liability Insurance:**

Should Permittee be required by the scope of work being performed on or adjacent to WMATA property to provide design services, the services of a professional engineer, including, but not limited

to stamping, sealing, or certifying blueprints or other construction-related documents, Permittee is required to maintain Professional Liability Insurance as follows:

1. Minimum Policy Limits of \$2,000,000, each claim.
2. Actual coverage or tail coverage must be purchased and maintained for a period of time equal to the statute of repose.
3. Coverage can be written on an “occurrence” or “claims made” basis.
4. Coverage can be written on ‘non-admitted” paper.

**Pollution Liability Insurance:**

Should Permittee be required by the scope of work being performed on or adjacent to WMATA property, to perform demolition of any pre-existing structures, moving, removal, or handling of any hazardous materials, Permittee is required to maintain Pollution Liability Coverage as follows:

1. Minimum Policy Limits of \$2,000,000, each claim.
2. Coverage can be written on an “occurrence” or “claims made” basis.
3. Coverage can be written on ‘non-admitted” paper.
4. Policy shall be endorsed with Additional Insured Endorsement(s) in compliance with the Additional Insured Section 22.8 of this Permit.
5. Policy shall be endorsed with a Waiver of Subrogation Endorsement(s) in compliance with the Waiver of Subrogation article of this Permit.

**Additional Insured(s):**

Permittee is required to add WMATA and the WMATA Board of Directors as Additional Insured(s) on all insurance policies purchased by Permittee with the exceptions of Workers’ Compensation and Professional Liability.

1. Coverage provided to any Additional Insured shall be primary and non-contributory to any other insurance available to the additional insured, including coverage afforded to WMATA as an Additional Insured by subcontractors, and from other third parties.
2. Coverage provided to any Additional Insured shall be for claims arising out of both ongoing operations and products and completed operations hazard. The coverage provided by the additional insured endorsement shall be at least as broad as the Insurance Service Office, Inc.’s Additional Insured Form CG 20 26 11 85 as determined by WMATA.

3. Coverage available to any Additional Insured under the products and completed operations hazard can only be limited to the applicable statute of repose in the jurisdiction where the contract scope of work takes place.
4. Coverage available to the Additional Insured shall not be limited to the minimum limits of coverage outlined in this document.

### **Waiver of Subrogation**

Permittee is required to have all insurance policies purchased by all Permittees endorsed to waive the insurance company's rights of recovery against WMATA, the WMATA Board of Directors, and all Permittees. Coverage shall be provided on an endorsement that is acceptable to WMATA.

### **Certificate of Insurance (COI)**

Permittee shall provide WMATA an ACORD Certificate of Insurance (COI) as evidence that the insurance requirements in this Permit have been satisfied. Certificates of Insurance shall be emailed to [COI@WMATA.com](mailto:COI@WMATA.com). The "Description of Operations" box in the COI should reference the Permit PCN number located at the top of page 1 of this Permit and the "Certificate Holder" box should state:

Washington Metropolitan Area Transit Authority  
Office of Risk Management, Room 8F  
600 Fifth Street, NW  
Washington, DC 20001

1. Proposed material modifications to insurance required under this section must be received by WMATA at least thirty (30) days prior to the effective date of the proposed modifications to such insurance.
2. WMATA's receipt of copies of any COI, policy endorsements or policies does not relieve Permittee of the obligation to remain in compliance with the requirements of this section at all times. Permittee's failure to so comply, and to continuously comply, with these insurance requirements shall constitute a material default of the terms of this Permit.
3. Receipt of the COI does not constitute acceptance of the insurance outlined above.

This page intentionally blank.

**WMATA MANUAL OF DESIGN CRITERIA  
SECTION 9**

**SECTION 9 RIGHT-OF-WAY**

**9.1 GENERAL**

**9.1.1 Policy**

Right-of-way is defined as the composite or total requirement of all real property interests and uses, both temporary and permanent, needed to construct, maintain, protect, and operate the Metro system.

WMATA's policy is to certify for acquisition the minimum right-of-way sufficient to construct, operate, and maintain the bus and rail transit system. The right-of-way plans approved by the WMATA Office of Chief Engineer Facilities (CENF) are used by the WMATA Office of Property Development and Management (LAND) as a basis for acquisition of property interests. LAND will make the final determination of the quantum of the estate in the land to be acquired.

For permanent easements, the Section Designer shall determine a right-of-way envelope which encompasses all permanent construction, drainage, future maintenance requirements, access roads, fire protection, utilities, rock bolts and any other permanent improvements or projections necessary for the construction, operation and maintenance of the system. In developing a right-of-way envelope, the cost of the land to be acquired should be factored into the proposed easement acquired.

The acquisition envelope is influenced by the topography, drainage, ditches, retaining walls, service roads, utilities, the nature of the structure and the slopes required. The limit of right-of-way shall be shown as an unbroken line which delineates the right-of-way with simple curves and connecting tangents. Chords may be used in lieu of large radius curves.

**9.2 Right-of-way Staging**

The Section Designer shall identify the minimum limits of the right-of-way during the design of the first or "structural" contract developed for a design section. Any subsequent contracts should not identify additional or new right-of-way required for that contract.

The first contract should identify the land that will be available for the first contract, the land that will be made available for any sequential contracts,

**WMATA MANUAL OF DESIGN CRITERIA  
SECTION 9**

and when in the construction cycle one contractor will make the land available for another contractor.

The contract drawings for the second contract need only identify the work areas that the second contractor will have available. The complete set of right-of-way drawings need not be inserted in subsequent contract drawing sets.

**9.3 DEFINITIONS OF RIGHT-OF-WAY EASEMENTS**

**9.3.1 Permanent Surface Easement**

A permanent surface easement shall provide sufficient space for the construction, operation, protection and maintenance of the Metro facility at the ground surface. The recommended easement width must incorporate basic track width, drainage, supporting slopes and utilities. Typical examples of permanent surface easements are sites for stations, traction power substations, chiller plants, vent and fan shafts, and other at-grade structures, in addition to at-grade tracks.

**9.3.2 Permanent Surface Easement with an Upper Limit**

A permanent surface easement with an upper limit shall provide space for the transit structures and for their future maintenance. This easement is applicable where structures such as a railroad or highway pass over Metro facilities. The easement shall have definite upper and lateral limits. A lower limit shall be described only when required.

**9.3.3 Permanent Underground Easement**

A permanent underground easement shall encompass the total Metro facility located beneath the surface of the ground. It shall have definite upper and lateral limits. Lower limits shall be described only where special limiting features exist.

**9.3.4 Permanent Aerial Easement**

A permanent aerial easement shall completely envelop the aerial portion of the Metro facility, with lower and lateral limits. An upper limit shall be described only where special limiting features exist.

**9.3.5 Utility Easement**

**WMATA MANUAL OF DESIGN CRITERIA  
SECTION 9**

A utility easement shall provide space for the relocation of existing utilities or the installation and maintenance of required or relocated utilities.

**9.3.6 Construction Easement**

A construction easement is a temporary easement or short term lease that provides sufficient space to allow for the temporary use of property by the Contractor during construction.

**9.3.7 Slope Easement**

A slope easement is a permanent surface easement for a cut or fill side slope to the tracks. A slope easement can be made revertible to the adjacent property owner if acceptable provisions are made for future support of the slope.

**9.3.8 Drainage Easement**

A drainage easement is a permanent surface easement for drainage of water along a prepared course.

**9.3.9 Electric Grounding Grid Easement**

The electric grounding grid at substations and tie breaker stations should be designed to be located in any permanent surface easements at the station. If such an arrangement is unworkable, then the grounding grid shall be located in an identifiable grounding grid easement. The grounding grid location should be monumented.

**9.3.10 Access Easement**

**9.4 DRAWING DETAILS**

Right-of-way drawings shall be 1" = 40' scale showing the relationship of the right-of-way to the street system and properties affected by construction. All existing topographic features shall be screened on the base sheets.

Show property lines and delineate affected parcel ownership along the right-of-way. When a property appears on more than one sheet of the right of-way plans, the total area of the easement required shall be shown in the Property Disposition Table on the first sheet on which the property appears. The property shall be listed in the property disposition table on



**WMATA MANUAL OF DESIGN CRITERIA  
SECTION 9**

each sheet on which it appears and shall be cross referenced to the sheet which delineates the area of the easement.

The right-of-way drawings shall have a designated grid system and north arrow reflecting the appropriate datum of WMATA's project grid or related USC&GS datum as appropriate for the area concerned.

**9.4.1 Format**

All right-of-way plans shall conform to the format established in the most current WMATA Right-of-way Design Drawings and Contract Drawing Standards.

**9.4.2 Graphic Symbols**

Graphic symbols used to describe easements shall be uniform and shall conform to the standard right-of-way legend ([see FIGURE 9.1](#)). Each sheet shall contain a legend describing only the symbols used on that sheet. The edge of each easement shall be marked with a neat line to mark the limit of the easement and to aid in distinguishing it from existing facilities or other easement symbols. The street system shall be clearly shown and identified by street names as well as Federal, State and/or County route numbers.

**9.4.3 Centerline**

The right-of-way plans shall show the centerline of the tracks and the outline of the structure, in addition to the limits of right-of-way which describes the right-of-way envelope. Stationing and station equations shall be shown in addition to contract limits. The beginning and ending points for curves and spirals on the centerline of both tracks shall be shown, as well as the dimension between tangent track centerlines. Show the outbound centerline stationing at property lines.

**9.4.4 Contractors' Work Areas**

Delineate on the drawings the property required for the contractors' use and show the limits of any additional easements, temporary or permanent, that are required to accommodate access, temporary roads, drainage and utilities. Show all structures that require razing prior to construction. Show temporary fencing or barriers around contractors' work areas. Determine the property owners of record affected by the above

**WMATA MANUAL OF DESIGN CRITERIA  
SECTION 9**

limits and show the property dispositions in table form with areas involved by type easement required.

Coordinate all of the requirements for the contractors' work areas at each end of the design section. The contractor's work areas for one design section shall not cross over into the adjacent section. If construction staging allows the use of an area in an adjacent design section, its use must be coordinated with WMATA and the adjacent section designer to avoid contractor confusion and claims.

**9.4.5 Property Surveys in the District of Columbia**

In the District of Columbia, the right-of-way envelope shall be dimensionally tied to existing copper corners. Copper corners, which are generally offset from the square corners or property lines, can only be established by the D.C. Surveyor, or a surveyor registered in D.C. After establishing a copper, the surveyor then prepares and records a plat showing the relationship between the established copper and the property line. Ties from the proposed limit of right-of-way to the property lines are also required.

The following procedure is to be followed when requesting copper corners:

- 9.4.5.1 The General Plans shall be reviewed by the Section Designer to determine the location of the copper corners needed to complete the design.
- 9.4.5.2 A search of the District of Columbia's survey records shall be conducted to determine the exact field location of each existing copper in the affected area.
- 9.4.5.3 A field check shall be made to determine the accuracy of all coppers located based on the copper locations taken from the D.C. survey records.
- 9.4.5.4 Coppers located and verified by the field check may be used in the design.
- 9.4.5.5 If additional copper corners are required to complete the right-of-way design, the Section Designer will provide a list of the desired corners to WMATA-CENF. WMATA shall request the D.C. Surveyor to mark the corners. WMATA shall monitor the D.C. Surveyor's progress.

**WMATA MANUAL OF DESIGN CRITERIA  
SECTION 9**

**9.4.5.6** WMATA shall establish the location of the coppers with respect to the Metro grid and place the coordinate values on the plats prepared and signed by the D.C. Surveyor. Plats with the coordinated copper corners shall be used in the design and the coordinated values of the copper corners shall be shown on the right-of-way plans. (It is emphasized that copper corners be requested as early as possible to avoid delay in design.) When calculating areas of required rights-of-way, each square affected by the right-of-way envelope must be considered separately.

**9.4.5.7** Written descriptions shall be in the D. C. meridian.

**9.4.6** **Property Surveys in Maryland and Virginia**

The WMATA right-of-way envelope on the plans shall be described by bearings and distances, ensuring that the pertinent portions of all tracts, subdivisions, U.S. lands, parcels, and other areas which are affected by the envelope are similarly described. Coordinates and elevations further describing the right-of-way limits and existing property corners shall be shown on the plans. Coordinates shall be provided for all angle and curve points along the limits of right-of-way. Properties that are affected by WMATA's right-of-way shall be shown in their entirety. Smaller scale (e.g. 1" = 200') drawings may be used.

The Section Designer shall prepare plats of survey for recordation in accordance with the requirements found in Section 9.4.7 and the minimum technical standards of the appropriate jurisdiction. The final plats shall comply with the requirements of the jurisdiction in which the property is situated. It is required in Arlington County (and strongly recommended for other jurisdictions) that the Section Designer submit the plats to the County (or City) having jurisdiction for their approval and comments. The plats shall be coordinated with WMATA prior to their submittal to the County (or City). Final plats shall be certified by a Land Surveyor registered in the applicable jurisdiction.

In 1974, the National Geodetic Survey (formerly the United States Coast and Geodetic Survey) adjusted the values of the horizontal control coordinates of all first order Triangulation Stations in Maryland and Virginia. WMATA mapping and control was generally based on the NAD27 1971 field geographic positions and coordinate values of these stations. One small section of WMATA's mapping and control (A-14 to A-17) was based upon

**WMATA MANUAL OF DESIGN CRITERIA  
SECTION 9**

**NAD27 1974 adjustment.** In either case, the Section Designers shall include on the right-of-way plans, and on the plats of recordation, a note that describes the coordinate datum and adjusted values which are the basis for the coordinates shown. Survey consultants performing surveys for WMATA shall endeavor to use the NAD27 1971 and 1974 positions where historically these positions have been used in the past. NAD83 1991 positions shall be used for all extensions beyond the 103 Mile System. Adjustment of existing control shall be limited to avoid complications due to the differences of accuracy, and its relationship to previously set rail centerline control points and right-of-way monuments.

**9.4.7 Plat of Survey Requirements**

- 9.4.7.1** A surveyor performing any boundary survey for WMATA shall follow the minimum technical jurisdictional requirements and the WMATA technical standards during the performance of the work. Deviation from these requirements shall require WMATA approval.
- 9.4.7.2** All original plats of boundary surveys shall be provided on durable reproducible film, drawn at a jurisdictionally approved suitable scale clearly indicating the compiled results of the field work, computations, research, and record information.
- 9.4.7.3** All plats shall be submitted to WMATA in the latest AutoCAD® and Portable Document Format (PDF) file formats. PDF files shall include seal and signature of the surveyor of record. All legal descriptions shall be submitted to WMATA in the latest Microsoft Word® and Portable Document Format (PDF) file formats. All plats and legal descriptions shall include separate area closure sheets output from the computational software showing computed coordinates, bearing and distances, areas and closure error for each parcel and shall be submitted as an ASCII text and Portable Document Format (PDF) file formats.
- 9.4.7.4** All plats and legal descriptions shall be signed and sealed by the record surveyor.
- 9.4.7.5** Plats may not be smaller than 8 ½ x 11 inches. Plats shall be prepared in multiples of 8 ½ x 11 inches or 8½ x 14 inches. Tic marks shall be placed on the plat to

**WMATA MANUAL OF DESIGN CRITERIA  
SECTION 9**

indicate the corners of the multiple rectangles. The scale of the plat shall be 1 inch = 100 feet or smaller. Excess blank space shall be avoided.

- 9.4.7.6 Dimensions, bearings, or angles, including sufficient data to define curves, shall be neatly and legibly shown with respect to each property boundary line. Tables of dimensions, bearings and angles shall be avoided.
- 9.4.7.7 All bearings shall be shown in a clockwise direction.
- 9.4.7.8 Building street address numbers, as displayed on the premises, or so noted if no numbers are displayed.
- 9.4.7.9 Markers shall be labeled as "found" or "set", with a brief description of the marker and relevant reference markers, if any, along with their positions in relation to the corner.
- 9.4.7.10 Natural or artificial features, where relevant, such as water courses, streets, curb lines, pavement lines and visible utilities, shall be labeled, dimensioned, and referenced to the nearest property boundary line or represented by a symbol on the plat in its proper location. Each symbol shall clearly indicate what is represented or shall be labeled for identification either individually or in a separate key of symbols or legend.
- 9.4.7.11 A statement indicating the origin and method of determination of the bearings shall be made on each plat, and the origin of the bearings shall include a reference to the WMATA approved local coordinate system with the controlling station names listed along with coordinate values.
- 9.4.7.12 Separate intricate details, blowups, or inserts may be used for clarity. They shall be properly referenced to the portion of the plat where they apply, particularly in areas where lines of occupation do not conform to the deed lines, and or where a comparison of adjoining deeds indicates the existence of a gap or overlap.
- 9.4.7.13 When record bearings or angles or distances differ from measured bearings, angles or distances, both the record and measured bearings, angles, and distances shall be clearly indicated. If the record description fails to form a

**WMATA MANUAL OF DESIGN CRITERIA  
SECTION 9**

mathematically closed figure, the surveyor shall so indicate.

- 9.4.7.14** Cemeteries and burial grounds found by the surveyor within the premises being surveyed shall be noted on the plat.
- 9.4.7.15** All evidence of monuments found beyond the subject tract, on which establishment of the corners of the subject tract are dependent, along with their application related to the survey shall be indicated.
- 9.4.7.16** Different line weights or delineating letters or numbers shall be used to clearly show the limits of the survey.
- 9.4.7.17** Easements and other physical encumbrances shown on the title shall be included on each plat along with all data necessary to establish or reestablish the location of the lines and the area of a strip or parcel of land designated on a tract of land for the specific use and benefit of others.
- 9.4.7.18** Upper and lower easement elevations and geometric delineation of easements required shall be shown on all plats.
- 9.4.7.19** WMATA structure lines and WMATA right-of-way lines shall be shown on all corresponding plats.
- 9.4.7.20** Permanent property interests required by WMATA shall be plainly and precisely identified on all corresponding plats.
- 9.4.7.21** The character of any and all evidence of possession shall be stated and the location of such evidence carefully given in relation to both the measured boundary lines and those established by the record. An absence of notation on the survey shall be presumptive of no observable evidence of possession.
- 9.4.7.22** Flood zone designation with proper annotation based on Federal Emergency Management Agency Flood Insurance Rate Maps or the state or local equivalent, by scaled map location and graphic plotting only shall be shown on each plat.

**WMATA MANUAL OF DESIGN CRITERIA  
SECTION 9**

- 9.4.7.23** The name of owner(s) of record and deed book reference where the acquisition was recorded shall be shown on all plats.
- 9.4.7.24** Adjoining properties will be shown and shall include record owner name(s), square number, block & lot number, parcel number, section number, and name of subdivision, as appropriate, or if not in a subdivision, Town/City and County. In addition, tax identification number and deed book & page shall also be shown on each plat.
- 9.4.7.25** Names and widths of streets and highways abutting the property surveyed and widths of right of way shall be shown on the plat. Distance to nearest intersection, based upon record data. If not available from record data, distance to nearest intersection may be determined from best available data, and so qualified.
- 9.4.7.26** Improvements such as any fixed permanent features including buildings, sheds, detached garages, structures, and fences shall be shown on each plat. The type of building construction shall be noted as brick, frame, steel, concrete, etc. All improvements shall be dimensioned (including number of stories and projections into public space) and shown on the plat. If no buildings exist a note shall be placed on the plat stating "No buildings".
- 9.4.7.27** Driveways and alleys on or crossing the property shall be shown. Where there is evidence of use by other than the occupants of the property, the surveyor must so indicate on the plat or map. Where driveways or alleys on adjoining properties encroach, in whole or in part, on the property being surveyed, the surveyor must so indicate on the plat or map with appropriate measurements.
- 9.4.7.28** A statement as to whether or not a current title report has been furnished to the surveyor along with title report number.
- 9.4.7.29** Building restriction line(s) per restrictive covenant, if shown on the record subdivision plat.

**WMATA MANUAL OF DESIGN CRITERIA  
SECTION 9**

- 9.4.7.30 All measured and record boundary line distances of parcels surveyed shall be shown.**
- 9.4.7.31 Date of plat certification (signing & sealing)**
- 9.4.7.32 Path & filename (digital)**
- 9.4.7.33 Survey contractor's project filename & number**
- 9.4.7.34 WMATA survey request number (if applicable)**
- 9.4.7.35 WMATA task order number (if applicable)**
- 9.4.7.36 WMATA line & section number (if applicable)**
- 9.4.7.37 CENF parcel number**
- 9.4.7.38 LAND parcel number**
- 9.4.7.39 QA review by signature block\**
- 9.4.7.40 Date of field survey**
- 9.4.7.41 Revision date(s)**
- 9.4.7.42 Name of surveyor**
- 9.4.7.43 Survey company name**
- 9.4.7.44 Survey company address and the phone number**
- 9.4.7.45 Client's name (survey prepared for)**
- 9.4.7.46 Title of survey**
- 9.4.7.47 Title report reference**
- 9.4.7.48 Classification of the survey (urban, suburban, rural, mountain and marshland)**
- 9.4.7.49 Scale of drawing**
- 9.4.7.50 Basis of bearings**
- 9.4.7.51 Datum (NAD83 or other datum approved by WMATA)**



**WMATA MANUAL OF DESIGN CRITERIA  
SECTION 9**

- 9.4.7.52 Gridlines / grid ticks**
- 9.4.7.53 Coordinate station names**
- 9.4.7.54 Coordinate station values for base control**
- 9.4.7.55 Coordinate station scale factor(s)**
- 9.4.7.56 North arrow**
- 9.4.7.57 Legend**
- 9.4.7.58 Signature, seal, printed license number of the surveyor & date block**
- 9.4.7.59 Property description & location**
- 9.4.7.60 Vicinity map**
- 9.4.7.61 Land area for each parcel (acreage)**
- 9.4.7.62 Point of commencement/point of beginning**

**9.4.8 Deliverables**

- 9.4.8.1 In addition to the right-of-way drawings, plats of survey and written metes and bounds descriptions of the proposed permanent easements shall be prepared by the Section Designer. Digital and hard copies shall be submitted to WMATA. The plats shall show both the record and the measured distances and bearings. Area closure sheets shall also be submitted.**
- 9.4.8.2 Fee interests are normally taken from railroad companies, in lieu of permanent surface easement. Therefore, plats of railroad property where WMATA will require permanent surface easement shall be prepared to show fee takings. (The right-of-way plans shall still show permanent surface easement in the railroad properties.)**

**9.4.9 Curve Data**

**The Section Designer shall reduce all spirals to circular curves at the limit of right-of-way. Circular curves are the only type of curves acceptable for recording purposes. Curve data shall be**

**WMATA MANUAL OF DESIGN CRITERIA  
SECTION 9**

shown on the right-of-way plan sheet on which the curve appears in a table of curve data. Tangent sections shall be used in lieu of curves to show the limits of the right-of-way when curves are extremely flat.

**9.4.10 Right-of-way for Aerial Structures**

**9.4.10.1** In determining right-of-way needs when dealing with aerial structures the Section Designer may use as a guide a horizontal distance of twenty-five feet (25'-0") from the centerline of the nearest track to the right-of-way line. This should provide sufficient space for fire protection and maintenance. Consideration shall be given to the location of adjoining buildings and property limits which could govern the extent of the right-of-way limits.

**9.4.10.2** The upper elevation of an aerial easement shall be a plane parallel with the datum, the upper elevation controlled by the highest point of the Metro structure. The upper elevation plane shall be stepped as necessary to prevent excessive takings. The steps shall be co-located with property lines, or other land features acceptable in land description practice. A lower limit will be required in most cases. Typical examples are a railroad passing under the WMATA facilities, or where the Metro passes over Federal Aid Highways, parking lots, or other facilities. Future requirements of access for maintenance purposes from ground elevation shall be considered in designing aerial rights-of-way.

**9.4.10.3** Within the aerial easement area the following rights are obtained as a minimum:

**9.4.10.3.1** Support rights for foundations, piers and other structural members.

**9.4.10.3.2** The right of unobstructed and unimpaired use of the aerial envelope.

**9.4.10.3.3** The right to prevent the transfer of loads to any part of the structure or foundations.

**9.4.10.3.4** Access rights for periodic inspection and maintenance of the structure and footings.

**WMATA MANUAL OF DESIGN CRITERIA  
SECTION 9**

**9.4.10.3.5** The right to prevent the storage of flammables, explosives or other hazardous materials under the aerial envelope.

**9.4.10.3.6** The right to install utilities beneath the surface of the ground within the easement area.

**9.4.10.3.7** The right to use the area of the aerial easement as a contractor's work area during construction.

**9.4.10.4** In property owned by the National Park Service (NPS) or by the General Services Administration (GSA), the areas for all easements required below the aerial easement shall be defined in the normal way.

**9.4.10.5** In designing the WMATA right-of-way, the Section Designer shall take the above criteria into consideration and any existing local, state and Federal requirements.

**9.4.11** Continuous Right-of-way

Even though WMATA may not require acquisition of public space, all plans shall show the right-of-way envelope as being continuous crossing public as well as private space.

**9.4.12** Isolated Right-of-way

The easement areas supporting all new construction such as fan and vent shafts, substations, escalators, and chiller plants shall be geometrically delineated as is the right-of-way envelope, with ties shown where the location is not contiguous to the right-of-way.

**9.4.13** Underground Vaults

Underground vaults (found mainly in the District of Columbia) that will be influenced by WMATA construction shall be shown and their disposition noted. The vaults shall be labeled in accordance with the following categories:

**9.4.13.1** Category "A" are those vaults which must be physically removed during construction.

**9.4.13.2** Category "B" are those vaults which lie within the influence line of construction, but may not require physical removal.

**WMATA MANUAL OF DESIGN CRITERIA  
SECTION 9**

**9.4.13.3** The influence line may generally be considered to project upwardly on a 1:1 slope from a point two feet (2') below the lowest point of excavation nearest the property line. Vaults not in Category "A" but within the influence line could experience cracking and utility lines may be subject to rupture. The owner may be required to abandon use of vaults designated Category "B" during construction.

**9.4.14 Multilevel Easements**

Multilevel easements may be required by WMATA at station entrances located in buildings. In such instances the Section Designer shall prepare a separate detail drawing showing the interests on each floor level. The following points shall be adhered to:

**9.4.14.1** Each floor level affected by the WMATA facility shall be so noted and separately illustrated. The area required on each level should be shown on each level of the detail, with the sum of the areas shown in the property disposition table for that property.

**9.4.14.2** Each type of easement on a floor level shall be properly dimensioned and symbolized. All footing and column locations shall be shown.

**9.4.14.3** The elevations of each floor easement shall be given and referenced to the project datum. Elevations shall normally be from the underside of the floor structure to the underside of the next higher floor structure.

**9.4.14.4** Access to each level of the easements must also be included in the design.

**9.4.15 Explanatory Notes**

Explanatory notes shall be used, where applicable, to aid in clarification of right-of-way takings.

**9.4.16 Construction Easements**

**9.4.16.1** Construction easements are temporary easements that are normally required only during construction. These easements do not need the detailed definition of permanent easements, as an agreement (lease) is normally entered into with the property owner. It is

**WMATA MANUAL OF DESIGN CRITERIA  
SECTION 9**

essential, however, that the Contractor be able to accurately locate the extent of the easement in the field. Thus, distances and ties to existing features are important.

- 9.4.16.2 If the proposed easement is isolated from the WMATA right-of-way, ties or coordinates sufficient to locate the easement in the field should be shown on the plans.
- 9.4.16.3 Where WMATA facilities will be built by cut-and-cover construction, a construction easement is required over the permanent underground easement that will envelope the structure. The area of the construction easement is to be noted in the property disposition table with an asterisk, which refers to a note of explanation: **"\* INCLUDES AREA ABOVE PERMANENT UNDERGROUND EASEMENT"**, placed above the Property Disposition Table. Plats are not required for construction easements, except in the event of condemnation. Plats used for condemnation are required to show construction easements by bearings and distances.

**9.5 RIGHT-OF-WAY LIMITS**

The Section Designer shall concurrently evaluate the right-of-way requirements for access, drainage, utilities, embankments, grades, alignments, and interfaces. The following criteria are provided as a guide for establishing the right-of-way limits. All right-of-way limits shall be defined as horizontal or vertical planes. The dimensions given herein are for general conditions and are to be modified where good sense, engineering, physical limitations, or real estate requirements dictate. The right-of-way limits will not always be concentric or parallel with the centerline of the tracks. Special attention shall be given to property takings, with the intent of avoiding takings where it is possible without adversely affecting the composite requirements of the Metro system. This may be accomplished by reducing or increasing the distance from the centerline of the tracks to the right-of-way limits or by stepping the limits around a certain property. The Section Designer shall establish the right-of-way limit to include the security fence and its support structure. Right-of-way limits should be developed which will allow minor adjustments as the design is refined.

The following distances are offered as a guide in establishing the final right-of-way requirements early in the design. Right-of-way

**WMATA MANUAL OF DESIGN CRITERIA  
SECTION 9**

widths at stations are based on 40'-6" track centers. Use of wider track centers will require additional right-of-way widths.

**9.5.1 At-Grade Structure ([See Figure 9.2](#))**

**Upper Limit:** Normally, an upper limit is not required. When an upper limit is required, the limit shall be described by the elevation of horizontal planes, stepped as required, locating the steps at existing property lines or prominent topographical features. The minimum distance from the top of the high rail to the horizontal plane is eighteen feet (18').

**Lateral Limits:** The Section Designer shall establish the right-of-way limits taking into account all requirements that apply to the alignment. The following distances shall be used as a guide:

**9.5.1.1** Normal at-grade section, five feet (5') from the toe or top of slope.

**9.5.1.2** Normal at-grade section with a drainage interceptor ditch, five feet (5') from the outside edge of the interceptor ditch.

**9.5.1.3** Restrictive and retained sections as approved by CENF.

**Lower Limit:** When required, the lower limit shall be defined in a manner similar to the upper limit, using a minimum distance of fifteen feet (15') below the top of low rail or fifteen feet (15') below the lowest flow line of adjacent drainage channels, whichever is lower.

**9.5.2 Aerial Structure ([See Figure 9.2](#), [Figure 9.10](#) and [Figure 9.11](#))**

**Lateral Limit:** Single track minimum fifty feet (50') total; double track on fourteen feet (14') centers, sixty four feet (64'). A lateral distance of twenty five feet (25') from the centerline of each track is to be maintained on wider track centers.

**Lower Limit:** A lower limit will normally be required under the aerial structure. The limit will vary from 1' to 4' below the bottom of the structure. The limit is delineated by elevations of horizontal planes, stepped as required, locating the steps at existing property lines or prominent suitable topographical features. For clearance requirements see Section 11.11.

**WMATA MANUAL OF DESIGN CRITERIA  
SECTION 9**

**Upper Limit:** An upper limit is generally not required; however, if required, the upper limit should be set at eighteen feet (18') above the top of the high rail.

**9.5.3 Rock Tunnel ([See Figure 9.2](#), [Figure 9.7](#), [Figure 9.8](#) and [Figure 9.9](#))**

Dimensions given in the aforementioned figures and following paragraphs are minimum distances. Actual dimensions may increase due to the conditions of the rock.

**Upper Limit:** The limit of the right-of-way is described by elevations of horizontal planes, stepped as required, locating the steps at existing property lines or prominent suitable topographical features. As a guide, a horizontal plane shall be used that is thirty five feet (35') above the top of the high rail for single track, forty feet (40') for double track, and seventy feet (70') at stations.

**Lateral Limit:** Vertical planes shall be used that are thirty feet (30') from the centerline of the nearest track. In station areas, use sixty feet (60') from the centerline of the station.

**Lower Limit:** Lower limits are normally not prescribed for rock tunnels. Where used, the lower limit shall be configured in a like manner to the upper limit, using a distance of fifteen feet (15') below the low rail.

**9.5.4 Earth Tunnel ([See Figure 9.2](#) and [Figure 9.6](#))**

**Upper Limit:** The limit of the right-of-way is described by elevations of horizontal planes, stepped as required, locating the steps at existing property lines or prominent suitable topographical features. As a guide, a horizontal plane twenty five feet (25') above the top of the high rail shall be used.

**Lateral Limit:** Fifteen feet (15') from the centerline of the nearest track.

**Lower Limit:** Where required by local jurisdictions or field conditions, a lower limit shall be configured in a manner similar to the upper limit using a distance of fifteen feet (15') below the top of the low rail.

**9.5.5 Cut and Cover ([See Figure 9.2](#), [Figure 9.3](#), [Figure 9.4](#) and [Figure 9.5](#))**

**WMATA MANUAL OF DESIGN CRITERIA  
SECTION 9**

**Upper Limit:** Twenty five feet (25') above the top of the high rail for single track, double track or triple track, and forty feet (40') at stations. The limit is delineated by elevations of horizontal planes, stepped as required, locating the steps at existing property lines or prominent suitable topographical features.

**Lateral Limit:** Fifteen feet (15') from the centerline of the nearest track. In station areas, forty feet (40') from the centerline of the stations.

**Lower Limit:** Where required by local jurisdiction or conditions.

**9.5.6 Storm Drainage**

Local requirements shall be adhered to where applicable. If there are no applicable local requirements, then the following shall apply:

**9.5.6.1 Open Ditches**

A minimum strip ten feet (10') wide is required for ditches where the design requires surface drainage. (See standard drawings for other ditch dimensions and slopes.) A two foot (2') wide clean-out shelf is required where the ditch is unpaved.

**Back and Front Slopes:** In soils, a maximum back or front slope of 2 1/2:1 shall be used. Where soil conditions would require excessive maintenance of a 2 1/2:1 slope, use a suitable flatter slope.

**9.5.6.2 Underground Drainage**

Widths of public easements for underground drainage systems shall be approved by the local approving agency.

**9.5.7 Stations**

All station platforms are 600' long, with ancillary rooms as an additional requirement. Station platforms shall be shown on the plans with stationing at each end of the platform. Right-of-way dimensions are delineated in paragraphs 9.5.1, 9.5.2, 9.5.3, 9.5.4, and 9.5.5.

**9.5.8 Projections in Public Space or Public Street Right-of-way**



**WMATA MANUAL OF DESIGN CRITERIA  
SECTION 9**

The Section Designer shall submit to WMATA a written list of projections into public space which must be removed to accommodate the construction of the metro facilities. This list should be submitted as soon as possible, but no later than the intermediate review submittal.

The projections list shall identify the type of projection, the location of the projection by square and lot number or by the tax assessor's designations, the street address, and the owner's name and address. Types of projections include vaults, fire escapes, signs, display windows, footings, foundations, and stairways.

**9.5.9 Escalator Requirements**

In addition to the structural, mechanical and electrical requirements for escalator space, the requirements for pedestrian circulation space to and from the escalators must be satisfied. A fifteen feet (15') wide longitudinal walking strip on either side of the finished escalator portal is required. A twenty feet (20') distance from the newels must also be preserved for pedestrian circulation. Exterior escalators require overhead protection from the elements. See standard canopy design drawings DD-A-CP-001 through DD-A-CP-008. Provide a minimum 15'-0" maintenance easement above the top of the canopy structure. The minimum head room above the escalator is twelve feet (12'-0") for escalator truss removal.

**9.5.10 Substations**

At-grade substations require an access road that is a minimum of eighteen feet (18') wide, with a twenty feet (20') long parking area and a turnaround sufficient for a WB-50 vehicle. The requirement for land will vary with the type of substation. The substation area should be contiguous to the limit of right-of-way for the transit way, where possible, with a five feet (5') maintenance space between the limit of right-of-way and the face of the substation structure.

Underground substations require an underground easement extending out ten feet (10') from the outside face of the structure.

Provision shall be made for permanent right-of-way for the electrical and communications cable ducts between the substation and the tracks.

**WMATA MANUAL OF DESIGN CRITERIA  
SECTION 9**

The electric grounding grid at substations shall be located within the permanent surface easement at the substation. If such an arrangement is unworkable, then the grounding grid shall be located in an identifiable grounding grid easement. The grounding grid location should be monumented.

**9.5.11 Tie Breaker Stations**

At-grade tie breaker stations require an access road that is a minimum of eighteen feet (18') wide, with a twenty feet (20') long parking area and a turnaround sufficient for a WB-50 vehicle. The requirement for land varies with the type of tie breaker station. The tie breaker area should be contiguous to the limit of right-of-way for the transit way, where possible, with a five feet (5') maintenance space between the limit of right-of-way and the face of the tie breaker structure.

Underground tie breaker stations require an underground easement extending out ten feet (10') from the outside face of the structure.

Provision shall be made for permanent right-of-way for the electrical and communications cable ducts between the tie breaker station and the tracks. The electric grounding grid at tie breaker stations shall be located within the permanent surface easement at the tie breaker station. If such an arrangement is unworkable, then the grounding grid shall be located in an identifiable grounding grid easement. The grounding grid location shall be monumented.

**9.5.12 Vent and Fan Shafts**

Vent and fan shafts shall be located in public space where possible. The gratings shall not exceed forty percent (40%) of the sidewalk width. When located on private property, the limit of right-of-way shall be five feet (5') from the outside face of the structure. Access to the shaft is required from the public street right-of-way.

**9.5.13 Chiller Plants**

At-grade chiller plants require five feet (5') from the face of the structure to the limit of the right-of-way. Suitable access is required.

**WMATA MANUAL OF DESIGN CRITERIA  
SECTION 9**

Chiller plants require additional space for the cooling tower when the cooling tower is located beside the mechanical plant instead of on top of the plant building. When chiller plants are located on existing buildings, a pipe and conduit chase shall be provided and required easements delineated on the right-of-way plans.

**9.5.14 Fencing**

All construction sites and contractor's areas shall have temporary fencing and suitable barricades where required to protect pedestrians and vehicles. It shall be noted on the plans that the contractor is required to fence only the area he will need to conduct his operations. The fencing will generally follow the limit of a construction easement. Contractor work areas in public space will be indicated by the limit of the construction fence. Dimensions of fencing may be scaled.

**9.5.15 Monumentation**

**9.5.15.1** The objective of WMATA's monumentation is to provide a broad network of survey control, right-of-way and boundary monuments from which WMATA's real property interests can accurately be identified.

**9.5.15.2 Definitions**

**9.5.15.2.1** Survey control monument A Metro monument consisting of a brass or bronze disc inscribed "METRO-CONTROL SURVEY", as shown on Standard Drawings ST-C-3 and ST-C-19. These are geodetically established, georeferenced monuments placed within Metrorail corridors. This is the primary survey control used to design and construct the Metrorail system.

**9.5.15.2.2** Right-of-way monument A Metro monument consisting of a brass or bronze disc inscribed "METRO-RIGHT-OF-WAY", as shown on Standard Drawings ST-C- 3 and ST-C-19. These are georeferenced monuments which document the boundary as determined by a registered surveyor.

**9.5.15.2.3** Boundary monument A steel rebar rod with aluminum cap inscribed "Metro - Property Monument," as shown on Standard Drawings, ST-C-3 and ST-C-19, are to be used to mark a corner or

**WMATA MANUAL OF DESIGN CRITERIA  
SECTION 9**

point on a boundary line. The registered surveyor setting the monument is to inscribe the cap with their registration number, WMATA Real Estate parcel number and point number, and comply with all jurisdictional regulations.

- 9.5.15.2.4** Witness post a fiberglass flexible post about six feet in length (one and one-half to two foot burial depth) used to mark a survey control, right-of-way or boundary monument located in open space, and provide an easily visible identifying reference to the monument. Witness posts may also be used to locate points on property lines when the line is not readily identifiable. See Standard Drawings ST-C-3 and ST-C-19 for details of the decal that is to be applied to all witness posts.

**9.5.15.3 Local Regulations**

- 9.5.15.3.1** Right-of-way monuments shall be installed at property corners to mark the WMATA right-of-way when jurisdictional regulations require it.
- 9.5.15.3.2** Where jurisdictional regulations require a boundary monument to mark property acquisitions or divisions in property, the local regulations shall govern. If jurisdictional regulations do not require monuments to be set, then WMATA policies shall apply. Refer to Section 9.5.15.4.
- 9.5.15.3.3** The monumentation for the right-of-way of WMATA facilities shall be accomplished in such a manner that the right-of-way lines can be readily re-established by a registered surveyor.

**9.5.15.4 Design Considerations**

- 9.5.15.4.1** It is WMATA policy to monument all Metro right-of-way in such a manner that the right-of-way line can be readily re-established on the ground by a registered surveyor currently licensed to practice in the appropriate jurisdiction. In order to have consistency among the many surveys made, or that will be made in the future, the Metro control survey network shall be considered the basis for all Metro right-of-way monumentation.

**WMATA MANUAL OF DESIGN CRITERIA  
SECTION 9**

**9.5.15.4.2 Right-of-way monuments shall be installed at property corners to mark the WMATA right-of-way. Right-of-way monuments shall be installed at all station entrances, on property lines adjacent to public spaces, and on property lines considered to be sensitive, as directed by WMATA. Setting the WMATA right-of-way lines shall be accomplished only after careful consideration has been given to adjacent property lines.**

**9.5.15.4.3 Coordinate values on boundary survey plats are to be shown in the applicable state plane system. Coordinate values on right-of-way plans are to be based on the project coordinate system in District of Columbia and Maryland and for part of the Huntington Route in Virginia. Coordinates in Virginia, except for part of the Huntington Route, are to be based on the Virginia State Plane Coordinate System, North Zone. State plane NAD83, 1991 coordinate values shall be utilized for various parts of the E-Route and the extension of the Outer G-Route.**

**9.5.15.5 Location of Monuments and Markers**

**9.5.15.5.1 It is WMATA's policy to set all property corners and to mark all underground utilities within the Metrorail right-of-way.**

**9.5.15.5.2 WMATA's control survey network shall be considered the basis for WMATA's right-of-way monumentation. Right-of-way monuments shall be set at angle points, at the beginning and ends of curves, and at intermediate points at intervals of not greater than 1000 feet.**

**9.5.15.5.3 Right-of-way monuments shall be placed where they would not normally be disturbed by WMATA maintenance operations, private grass cutting, future construction, and where their use would not create a hazard for the public or surveyors.**

**9.5.15.5.4 Boundary monuments shall be set in accordance with local laws, ordinances and regulations. Boundary monuments will not be set in the District**

**WMATA MANUAL OF DESIGN CRITERIA  
SECTION 9**

of Columbia as this is the prerogative of the Surveyor, D.C.

**9.5.15.5.5 Right-of-way monuments shall be set at Metrorail station entrances to define the limits of the WMATA surface property interests. Brass or other disks shall be used to mark the corners.**

**9.5.15.5.6 Control survey monuments shall be set following construction of WMATA concrete structures.**

**9.5.15.6 Monumentation of surface, underground, aerial and utility rights-of-ways**

**9.5.15.6.1 Surface right-of-way:**

Right-of-way monuments shall be located outside of the WMATA security fence.

**9.5.15.6.2 Underground right-of-way:**

Right-of-way monuments shall not normally be used to mark WMATA underground occupancy of public space. On WMATA property, survey control monuments shall be set in readily accessible places such as entrances, dome relief curbs, elevator openings, and fan and vent shafts' concrete structures.

**9.5.15.6.3 Aerial right-of-way:**

Right-of-way monuments shall not normally be used to mark these rights-of-way.

**9.5.15.6.4 Utility right-of-way:**

All underground utility lines will be marked in accordance with Standard Drawing ST-U-66.

**9.5.16 Underpinning Construction Easements**

The Section Designer shall provide detailed plans of the right-of-way necessary for the underpinning required by the design. Separate drawings showing the easements required for the construction contractor shall be prepared and referenced in the Property Disposition Table under "Remarks". The underpinning

**WMATA MANUAL OF DESIGN CRITERIA  
SECTION 9**

detail shall show the dimensions of the easements and tie the easements to the WMATA right-of-way, the property line, and the supporting columns of the structures. All footing and column locations shall be shown. Proposed access to the work areas through the building and location of dust walls shall be shown (see Section 15.7).

**9.5.17 Street Closings**

Provide separate drawings showing the areas of public property to be closed and utilized for WMATA. These drawings shall be prepared in accordance with all local requirements. The local plat requirements generally conform to the requirements for subdivision plats.

**9.5.18 Utility Easements**

Utility easements shall be treated as rights-of-way. Bearings and distances along the centerline shall be shown as well as the lengths and widths of the easements, and ties to the limits of right-of-way. All easements and clearances shall be in accordance with the Federal, State, local, and utility regulations and policies. All easements for new or relocated utilities shall be described by a metes and bounds description based upon the required plat.

**9.5.19 Elevators**

Provide direct access from elevators to public space. The access shall be a minimum of fifteen feet (15') wide, in addition to the space required for the queuing area. Provide for access to machine rooms, hoistways, elevator pits, etc., as required by the applicable code. Right-of-way for required utility services to the elevators shall be provided in accordance with the local jurisdiction requirements.

# WMATA MANUAL OF DESIGN CRITERIA SECTION 9

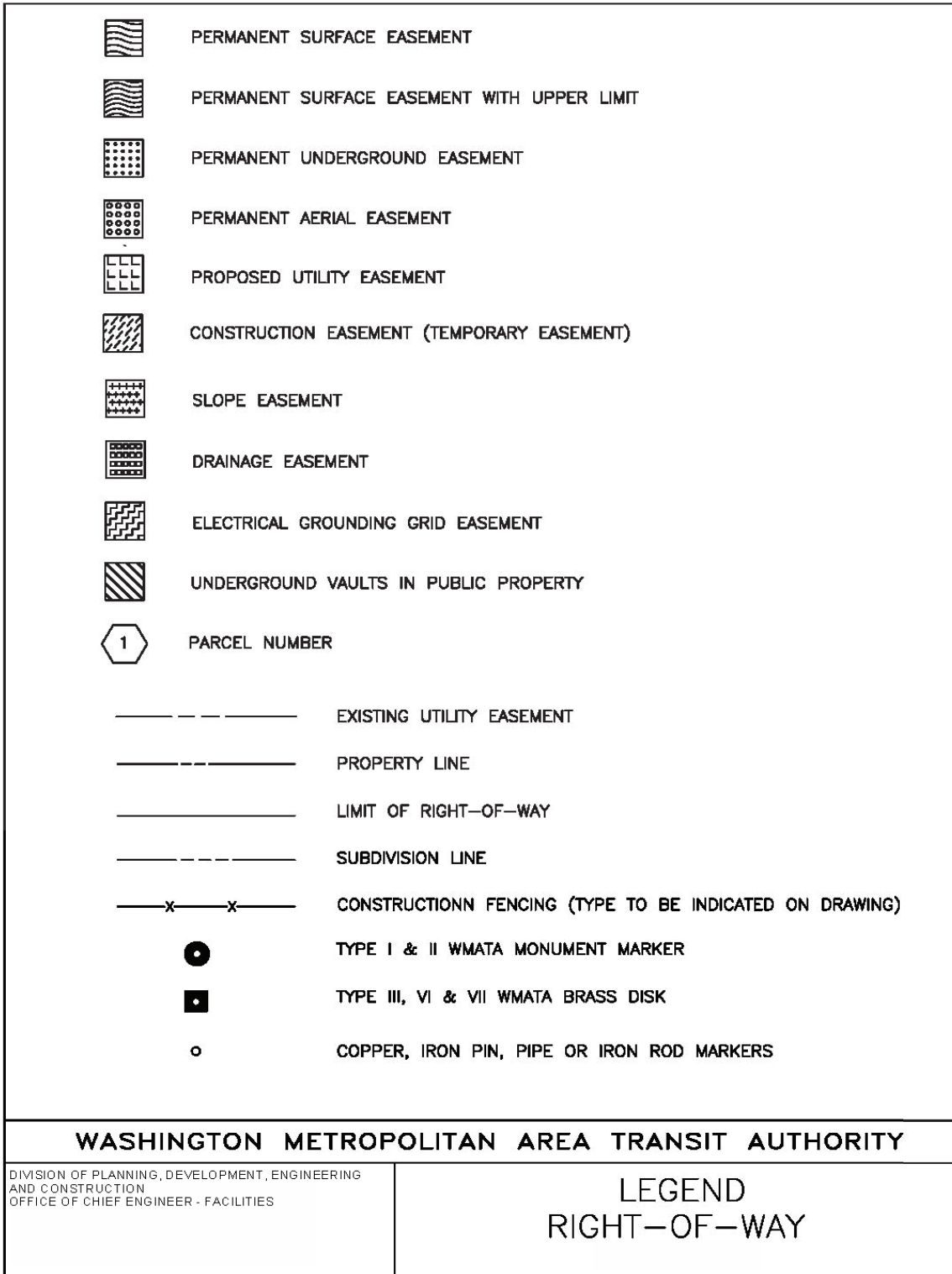

Figure 9.1



**WMATA MANUAL OF DESIGN CRITERIA  
SECTION 9**

TYPE CONSTRUCTION	AT GRADE		CUT & COVER	EARTH TUNNEL	ROCK TUNNEL	AERIAL
TYPE EASEMENT (PERMANENT)	SURFACE	SURFACE WITH UPPER LIMIT	UNDERGROUND	UNDERGROUND	UNDERGROUND	AERIAL
UPPER LIMIT	N/A	18' ABOVE T/R _____ 13' ABOVE T/R UNDER BRIDGES	SINGLE TRACK—25' ABOVE T/R DBL OR TRPL—25' ABOVE T/R STATIONS—40' ABOVE T/R	25' ABOVE T/R	1. SINGLE TRACK 35' ABOVE T/R 2. DOUBLE TRACK 40' ABOVE T/R 3. AT STATION 70' ABOVE T/R	18' ABOVE T/R
LOWER LIMIT (WHERE REQUIRED BY JURISDICTIONS)	15' BELOW T/R		15' BELOW T/R _____ STATIONS—20' BELOW T/R	15' BELOW T/R	15' BELOW T/R	VARIES 1' TO 4' BELOW BOTTOM OF STRUCTURE
LATERAL LIMITS	EXCLUSIVE ROW VARIES (SEE DESIGN DRAWINGS)		15' FROM $\text{C}$ NEAREST TRACK _____ 40' FROM $\text{C}$ STATIONS	15' FROM $\text{C}$ NEAREST TRACK	30' FROM $\text{C}$ NEAREST TRACK _____ 60' FROM $\text{C}$ STATIONS	SINGLE TRACK 50' _____ DOUBLE TRACK 25' FROM $\text{C}$ EACH TRACK
	RESTRICTIVE ROW AS APPROVED (SEE DESIGN DRAWINGS)					
<p>NOTES:</p> <ol style="list-style-type: none"> <li>DISTANCES SHOWN ARE MINIMUM AND ARE TO BE INCREASED WHERE ENGINEERING REQUIREMENTS SUCH AS ROCK BOLTS, SERVICE ROADS OR DRAINAGE DICTATE ADDITIONAL NEEDS.</li> <li>ALL LIMITS OF RIGHT-OF-WAY ARE TO BE VERTICAL OR HORIZONTAL PLANES.</li> <li>FOR UNDERGROUND EASEMENTS, WHERE THE DISTANCE SPECIFIED FOR THE UPPER LIMIT EXTENDS ABOVE THE GROUND SURFACE, USE THE GROUND SURFACE AS THE UPPER LIMIT.</li> </ol>						

**WASHINGTON METROPOLITAN AREA TRANSIT AUTHORITY**

DIVISION OF PLANNING, DEVELOPMENT, ENGINEERING AND CONSTRUCTION  
OFFICE OF CHIEF ENGINEER - FACILITIES

**MINIMUM RIGHT-OF-WAY**

Figure 9.2

**WMATA MANUAL OF DESIGN CRITERIA  
SECTION 9**

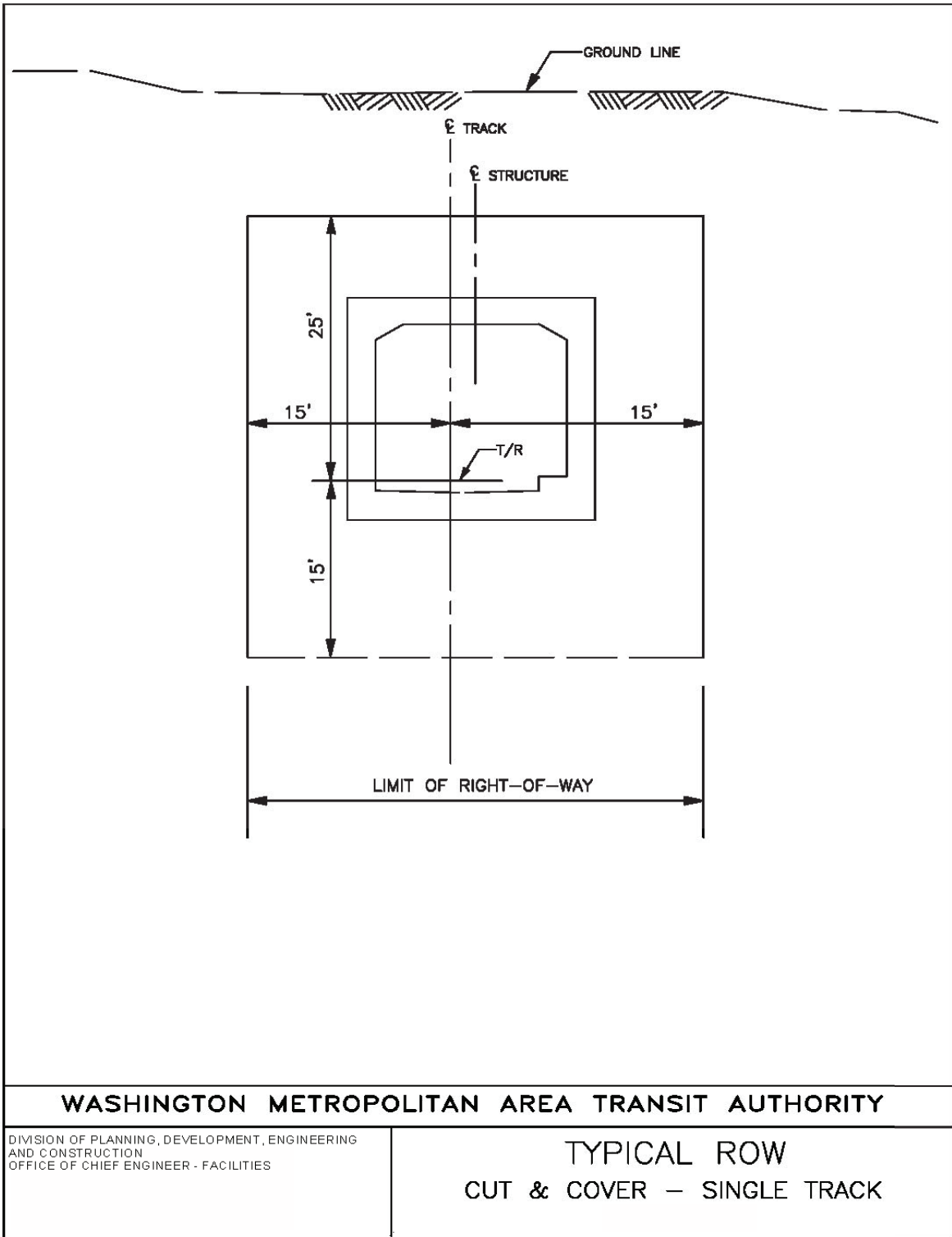

**WASHINGTON METROPOLITAN AREA TRANSIT AUTHORITY**

DIVISION OF PLANNING, DEVELOPMENT, ENGINEERING  
AND CONSTRUCTION  
OFFICE OF CHIEF ENGINEER - FACILITIES

**TYPICAL ROW  
CUT & COVER – SINGLE TRACK**

**Figure 9.3**

WMATA MANUAL OF DESIGN CRITERIA  
SECTION 9

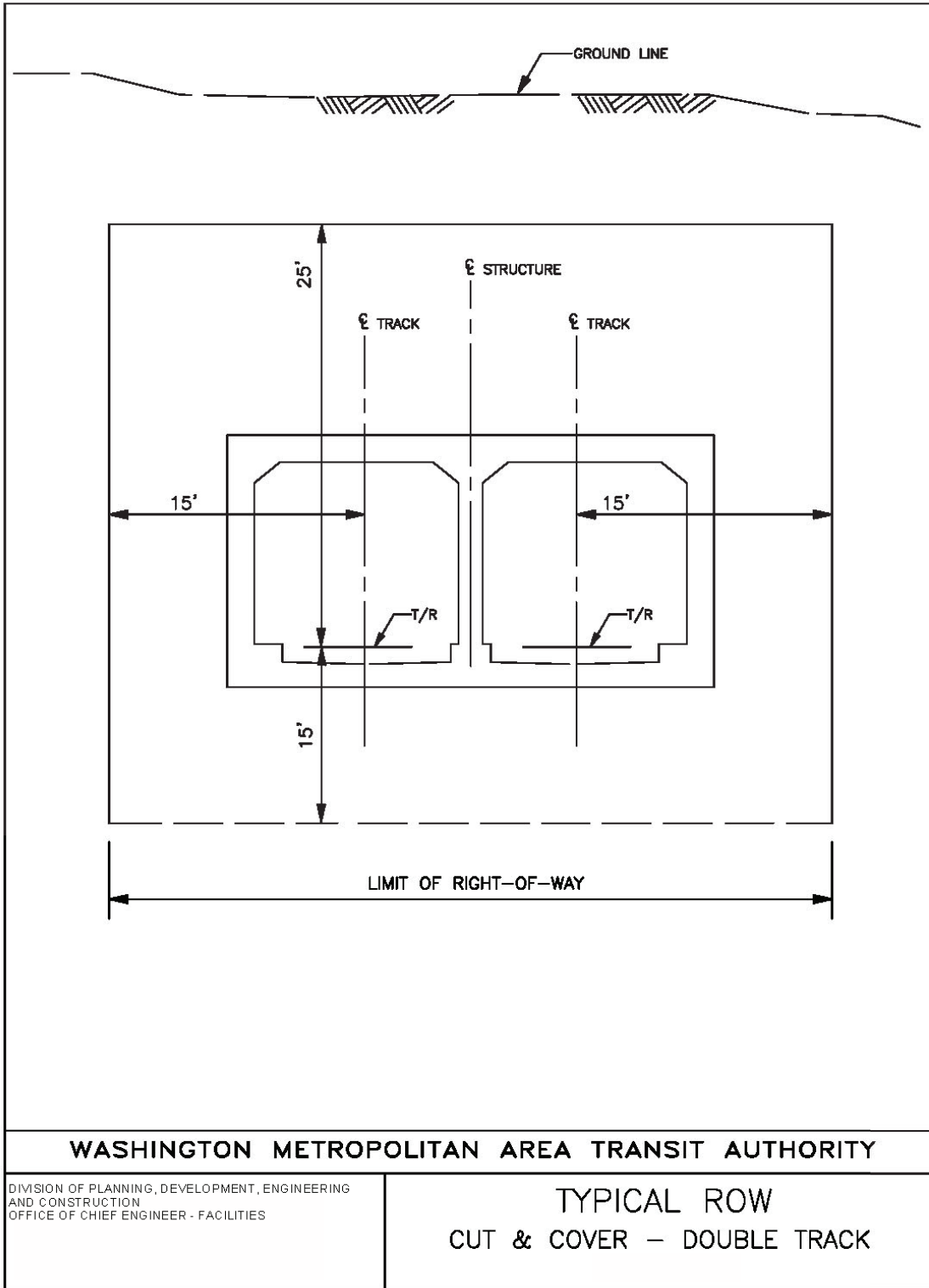

Figure 9.4

WMATA MANUAL OF DESIGN CRITERIA  
SECTION 9

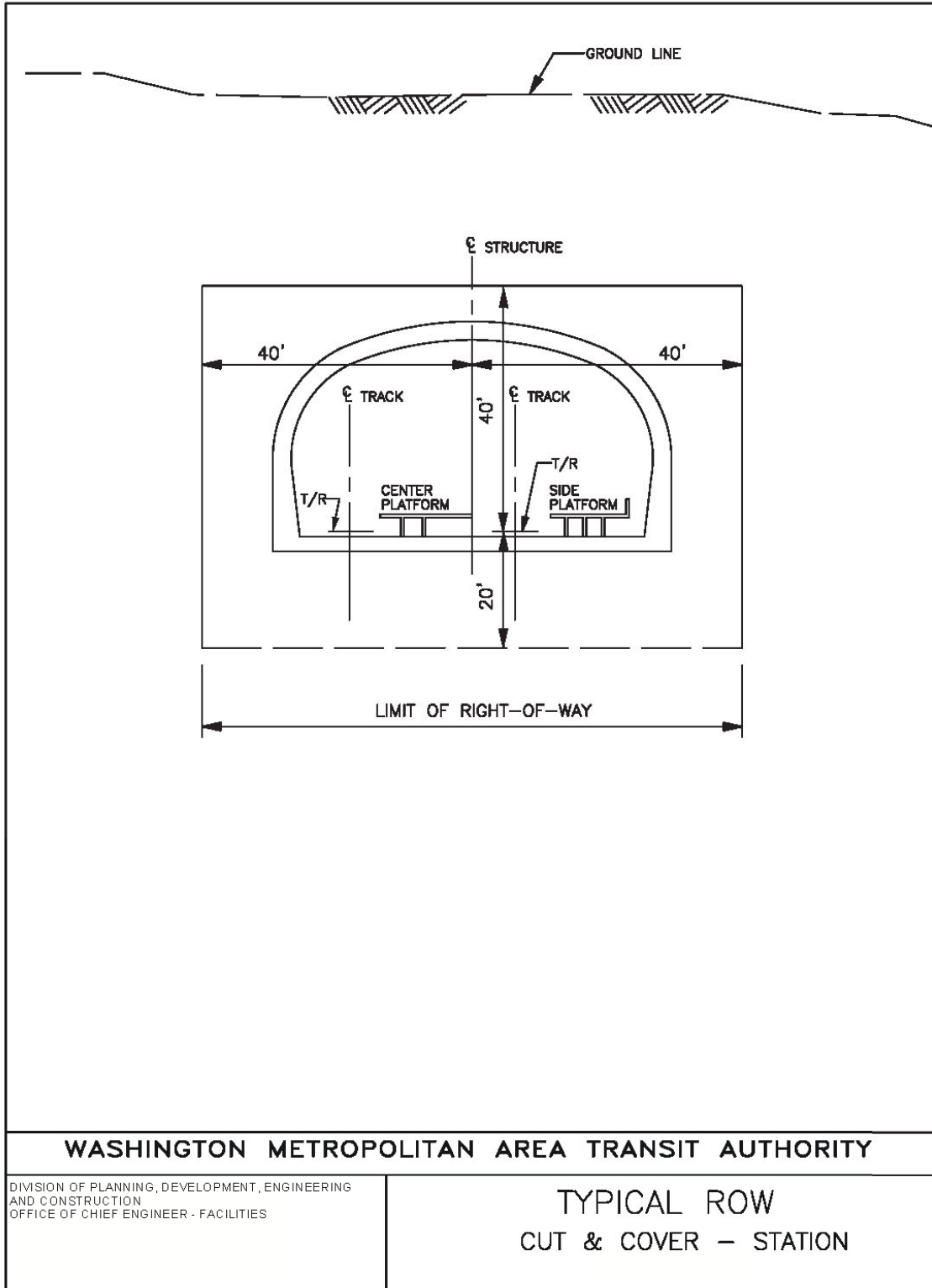

Figure 9.5

WMATA MANUAL OF DESIGN CRITERIA  
SECTION 9

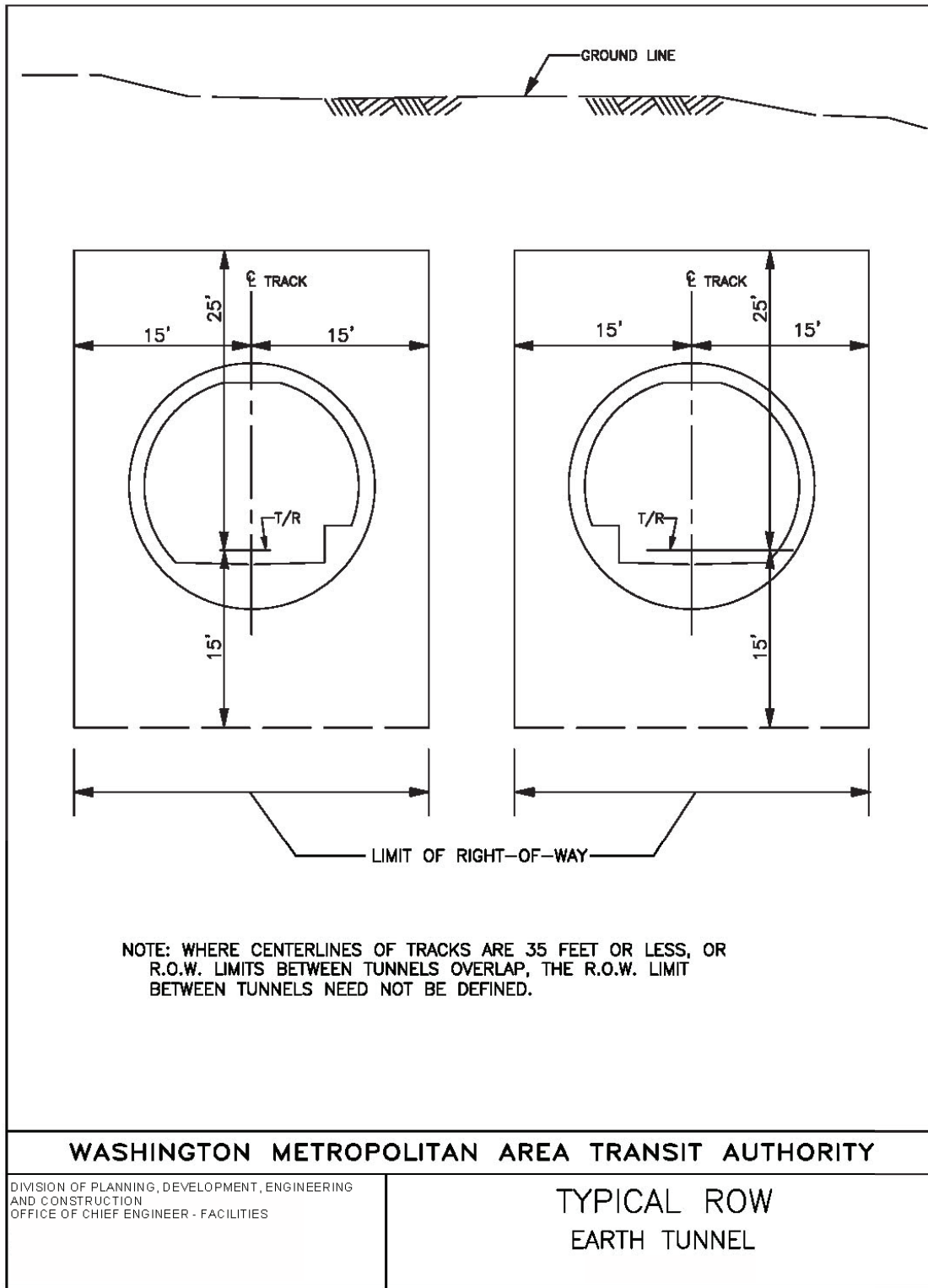

Figure 9.6

WMATA MANUAL OF DESIGN CRITERIA  
SECTION 9

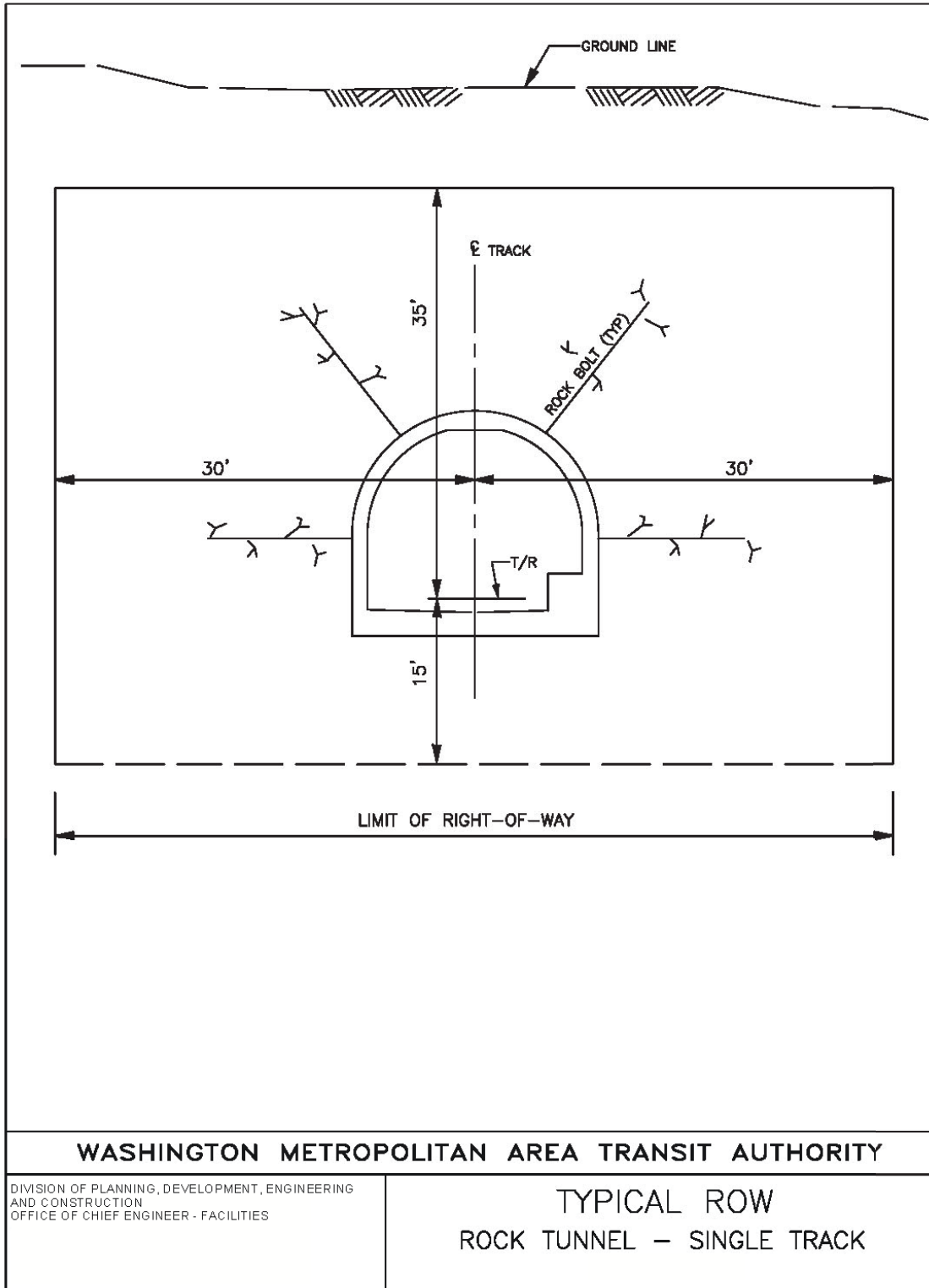
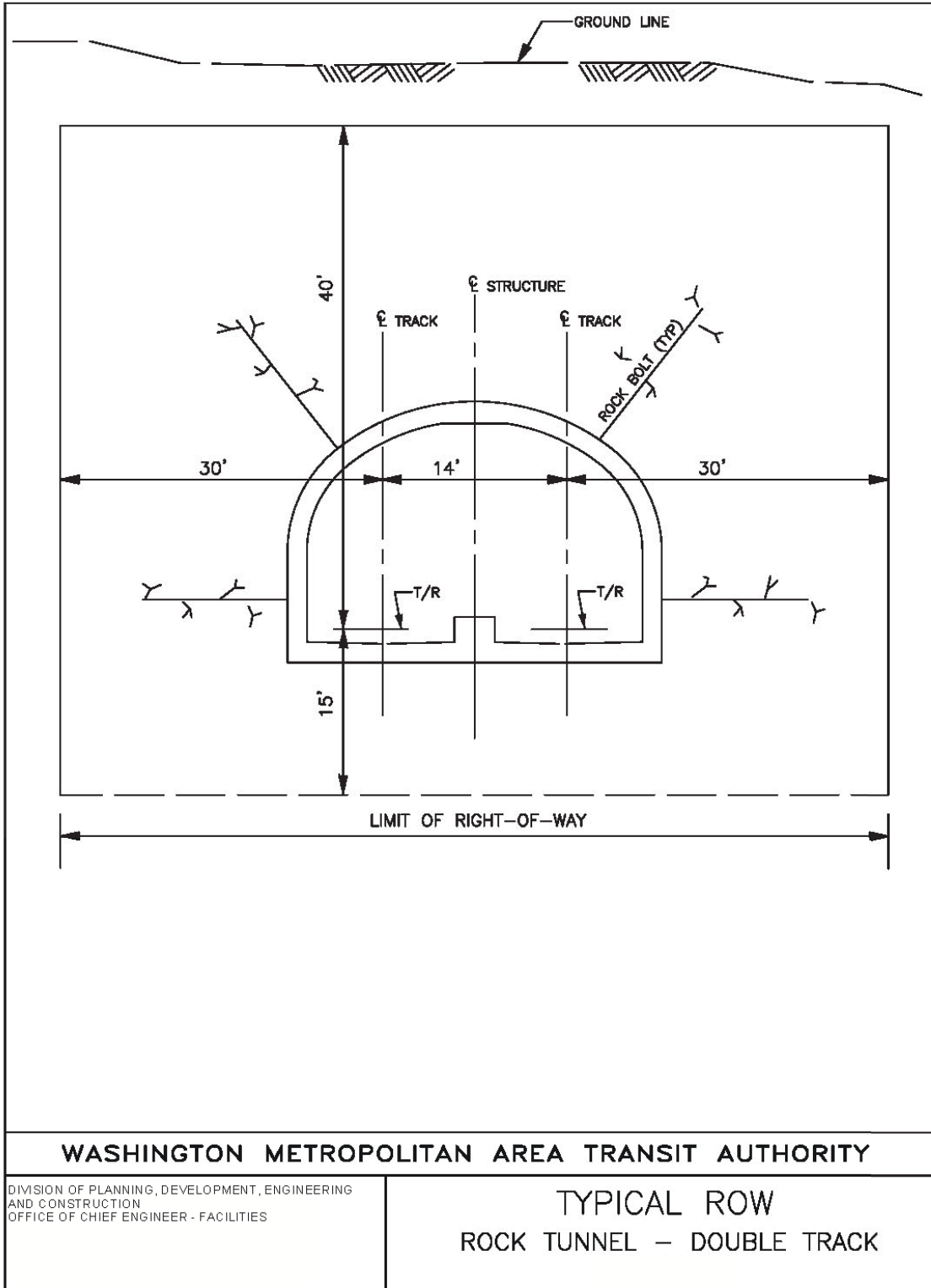

Figure 9.7

**WMATA MANUAL OF DESIGN CRITERIA  
SECTION 9**



**Figure 9.8**

WMATA MANUAL OF DESIGN CRITERIA  
SECTION 9

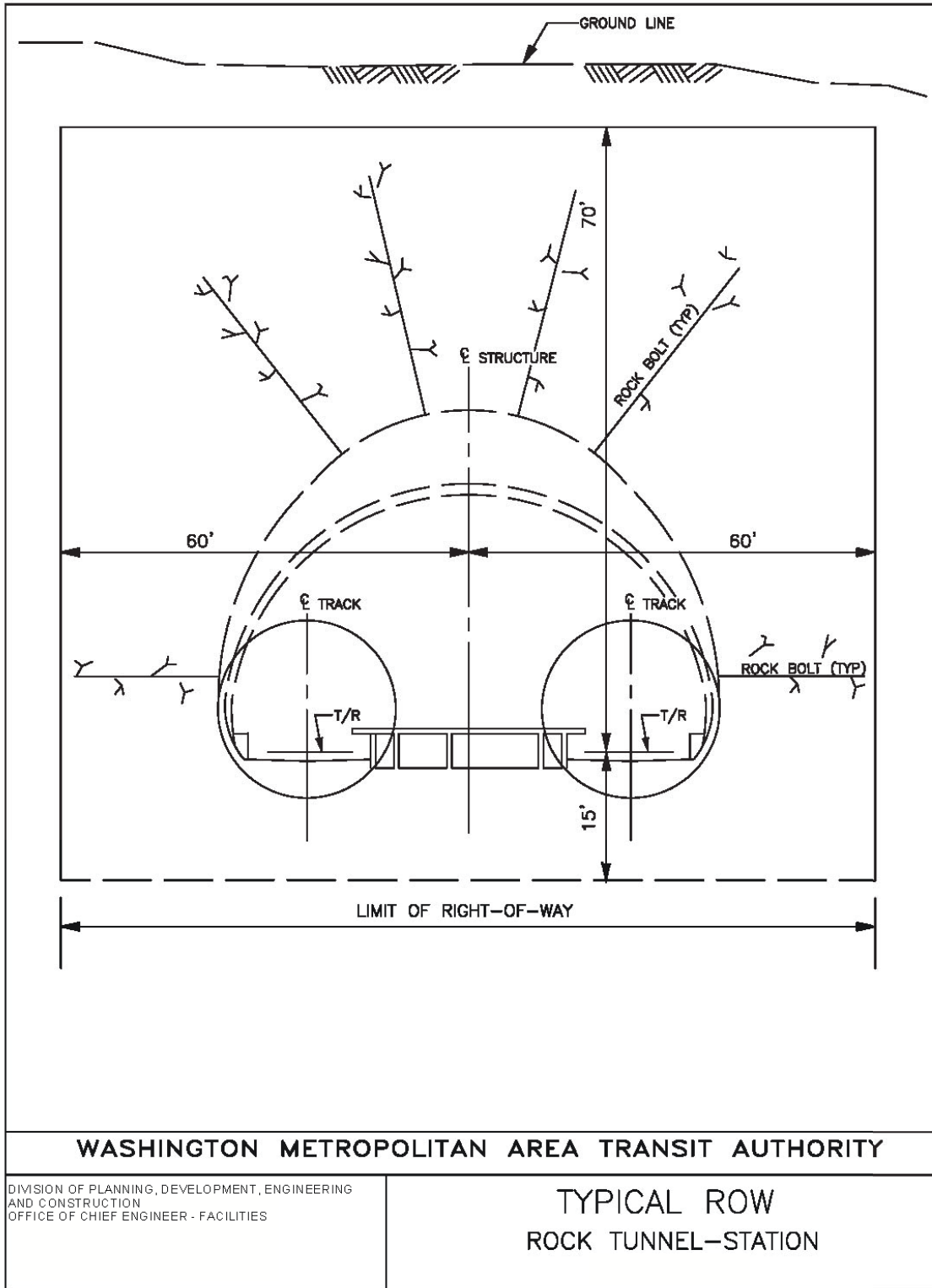

Figure 9.9



WMATA MANUAL OF DESIGN CRITERIA  
SECTION 9

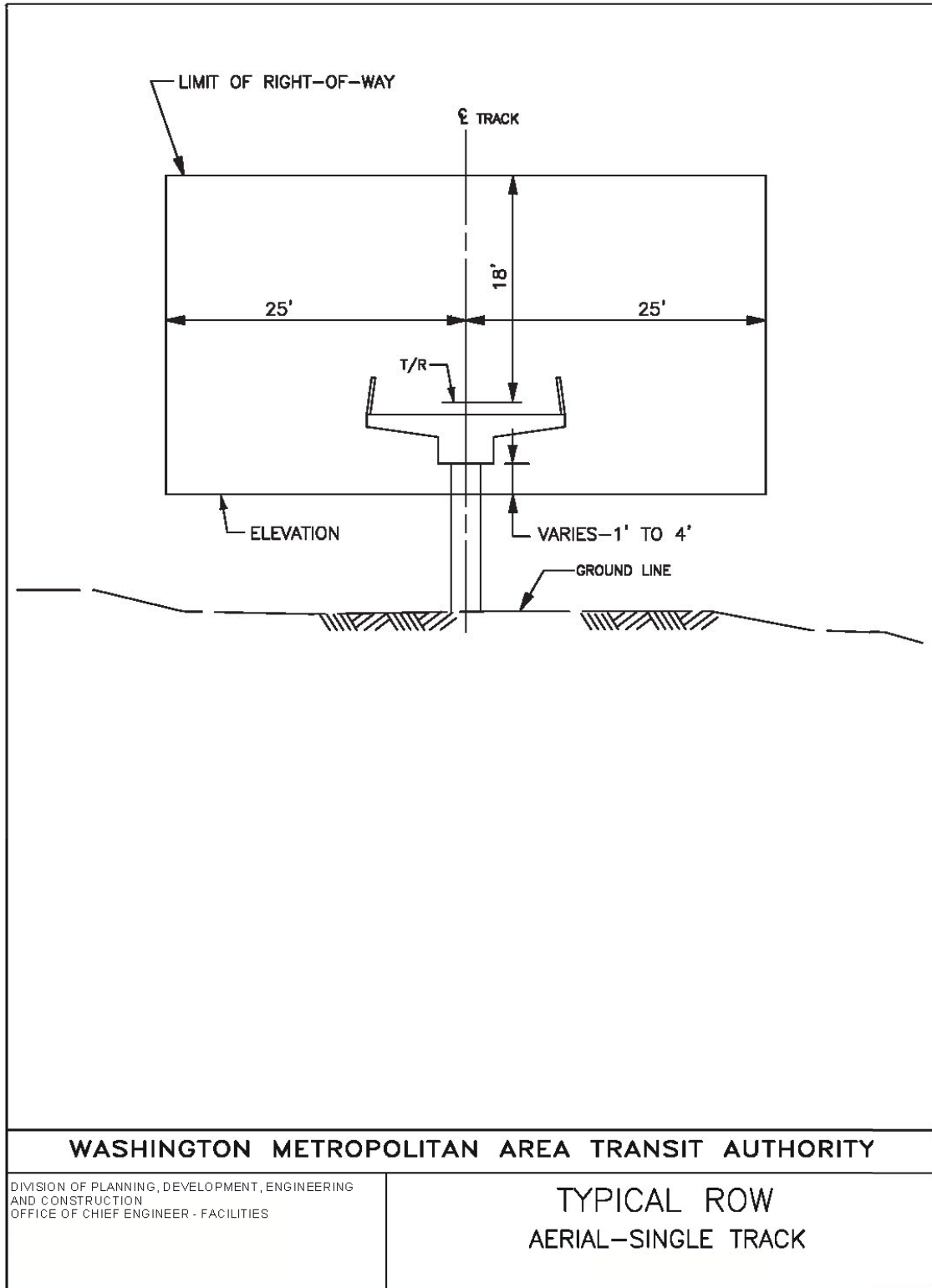

Figure 9.10

WMATA MANUAL OF DESIGN CRITERIA  
SECTION 9

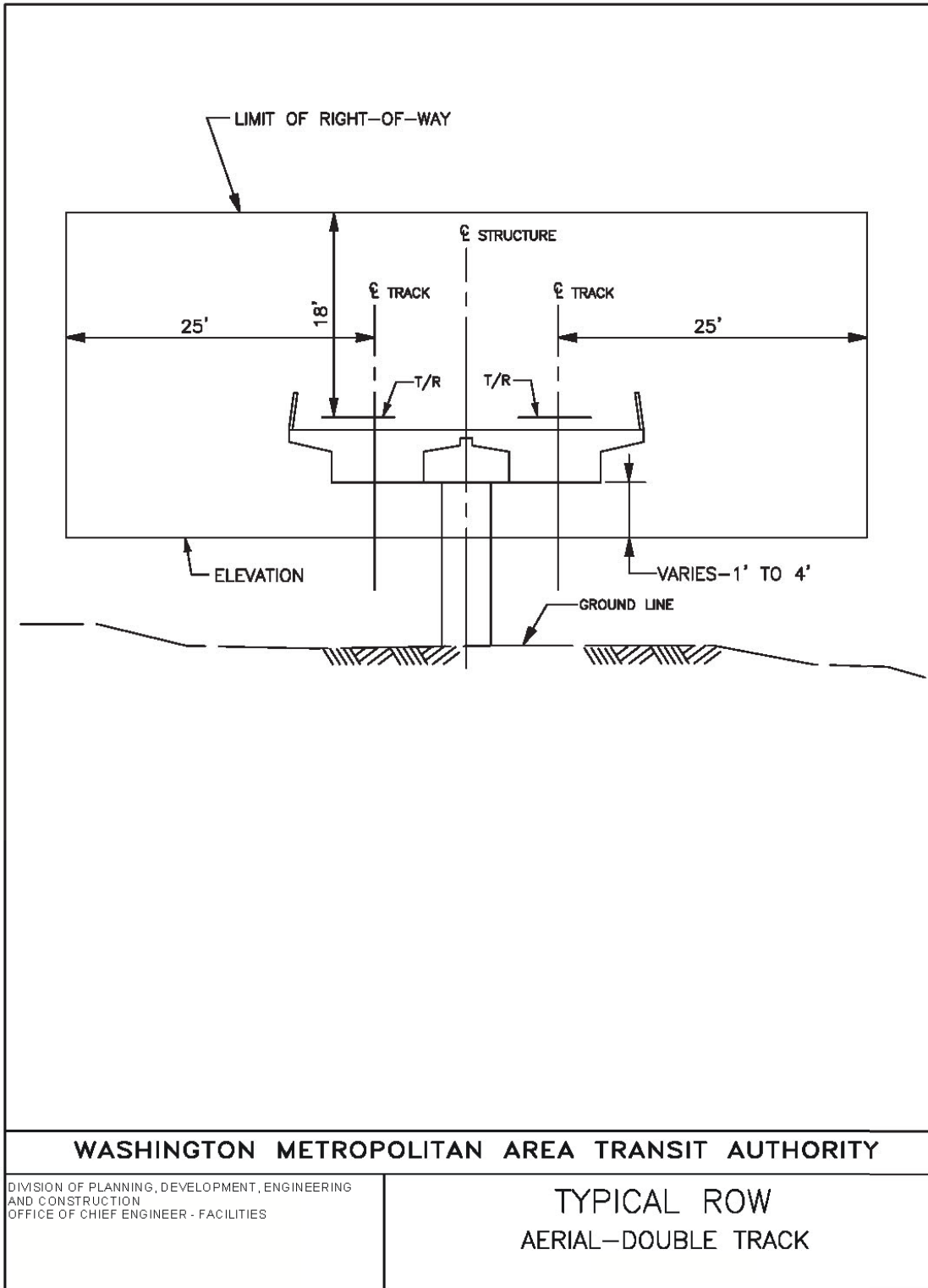

Figure 9.11

This Page intentionally blank.

## **Appendix 7 – As-Built Documentation and Closeout**

WMATA's As-Built Documentation Format

This page intentionally blank.

**WMATA's As-Built Documentation Format**

**NOTES:**

1. The WMATA Section Designation must be identified. Example: Medical Center Project is **A10**.
2. All As-built documentation shall be provided in required formats with applicable Professional Engineer seal.
3. All As-built drawings sheets shall be individually provided in both .pdf format and CADD format.
4. The .pdf and CADD files shall be accompanied with an Excel Spreadsheet that lists all pertinent information about each document. A sample of the Excel Spreadsheet form is shown below.
5. The title blocks on all drawings should correlate with the information that appears on each row of the spreadsheet.
6. Other Miscellaneous WMATA Documentation includes all issued reports, calculations, etc.

**SAMPLE**

Document Designation/ Number	Document Revision No.	Discipline	Sub-Discipline	Sub-Sub Discipline (if applicable)	Title of Document	Document Issue Date	Document Final Status	Document Description / Type	AutoCAD File Name	PDF File Name	WMATA Location
A10-A-932	5	ARCHITECTURE	SYSTEM WIDE	WAYSIDE BUILDINGS	EXTENSION TO WIEHLE AVE WAYSIDE BUILDINGS TYPICAL DETAILS	4-Feb-14	IFC - issued for Construction	Drawing	A10-A-932. AutoCAD extension	A10-A-932.pdf	A10 - Medical Center
A10-ATC-400	0	AUTOMATIC TRAIN CONTROL	SYSTEM WIDE	CONDUITS	AS-BUILT EXTENSION TO WIEHLE AVE- DIRECT FIXATION INTERLOCKING ATC CONDUIT REQUIREMENTS (FOR REFERENCE)	31-May-14	IFC - issued for Construction	Drawing	A10-ATC-400. AutoCAD extension	A10-ATC-400.pdf	A10 - Medical Center
A10-C-001	2	CIVIL	PLANS		EXTENSION TO WIEHLE AVE SYSTEM WIDE SYSTEM KEY PLAN AND VICINITY MAP	11-Jun-14	IFC - issued for Construction	Drawing	A10-C-001. AutoCAD extension	A10-C-001.pdf	A10 - Medical Center
A10-C-014	5	CIVIL	GENERAL NOTES	GENERAL NOTES	EXTENSION TO WIEHLE AVE SYSTEM WIDE CIVIL ABBREVIATIONS	18-Dec-14	IFC - issued for Construction	Drawing	A10-C-014. AutoCAD extension	A10-C-014.pdf	A10 - Medical Center
A10-C-022	2	CIVIL	SURVEY		EXTENSION TO WIEHLE AVE SYSTEM WIDE SURVEY CONTROL	18-Jun-14	issued	Drawing	A10-C-022. AutoCAD extension	A10-C-022.pdf	A10 - Medical Center
Geotechnical Report	0	GEOTECHNICAL			Insert - Title of Report		issued	Report		Filename.pdf	A10 - Medical Center
Structural Calculations	0	STRUCTURAL			Insert - Title of Calculation		issued	Calculation		Filename.pdf	A10 - Medical Center

This page intentionally blank.

# Abbreviations

<b>ACPM</b>	<b>Adjacent Construction Project Manual</b>
<b>AASHTO:</b>	<b>American Association of State Highway and Transportation Officials</b>
<b>ADA:</b>	<b>American Disability Association</b>
<b>AISC:</b>	<b>American Institute of Steel Construction</b>
<b>ANSI:</b>	<b>American National Standards Institute</b>
<b>BPLN:</b>	<b>Bus Planning</b>
<b>CCTV:</b>	<b>closed circuit television</b>
<b>CD:</b>	<b>compact disk</b>
<b>CE:</b>	<b>Construction Engineer</b>
<b>EOR:</b>	<b>Engineer of Record</b>
<b>FGCC:</b>	<b>Federal Geodetic Control Committee</b>
<b>GOTRS:</b>	<b>General Orders Track Rights System</b>
<b>GUTS:</b>	<b>guaranteed ultimate tensile strength</b>
<b>IDW:</b>	<b>intrusion detection warning</b>
<b>JDAC:</b>	<b>Office of Joint Development &amp; Adjacent Construction</b>
<b>LAND:</b>	<b>Office of Real Estate &amp; Station Planning</b>
<b>MSDS:</b>	<b>Material Safety Data Sheet</b>
<b>MOC:</b>	<b>Maintenance Operation Center</b>
<b>NACE:</b>	<b>National Association of Corrosion Engineers</b>
<b>NATM:</b>	<b>New Austrian Tunneling Method</b>
<b>NCCCO:</b>	<b>National Commission for the Certification of Crane Operators</b>
<b>NFPA:</b>	<b>National Fire Protection Association</b>
<b>ODC:</b>	<b>Owner Developer Contractor</b>
<b>OSHA:</b>	<b>Occupational Safety and Health Administration</b>
<b>PCN:</b>	<b>Project Control Number</b>
<b>PDF:</b>	<b>portable document format</b>
<b>PEPCO:</b>	<b>Potomac Electric Power Company</b>
<b>PPV:</b>	<b>peak particle velocity</b>
<b>RWIC:</b>	<b>Roadway Worker in Charge</b>
<b>ROCC:</b>	<b>Rail Operations Control Center</b>
<b>ROW:</b>	<b>Right-of-Way</b>
<b>RWPT:</b>	<b>Roadway Worker Protection Training</b>
<b>SAFE:</b>	<b>Department of Safety and Environmental Management</b>
<b>SSWP:</b>	<b>Site Specific Work Plan</b>
<b>TAMC:</b>	<b>Track Access for Maintenance and Construction</b>
<b>TIF:</b>	<b>Tagged Image Format</b>
<b>UFAS:</b>	<b>Uniform Federal Accessibility Standards</b>
<b>WMATA:</b>	<b>Washington Metropolitan Area Transit Authority</b>
<b>ZOI:</b>	<b>Zone of Influence</b>



This page intentionally blank.

## Glossary

**ACTUAL WORK AREA:** The specific location of work on WMATA's railroad contained in the protected work area that has boundaries established by reflective rubber mats.

**ADJACENT CONSTRUCTION:** Any project by others which include WMATA-owned or controlled real property or rights-of-way pursuant to an easement, lease, license or permit granted by WMATA.

**ATC:** Automatic Train Control

**AUTOMOBILE LIABILITY INSURANCE:** A commercial auto insurance policy covering the use of all owned, non-owned, hired, rented or leased vehicles bearing valid license plates appropriate for the circumstances for which the vehicles are being used.

**BUILDER'S RISK INSURANCE:** An insurance policy covering all risk of physical damage to property under construction.

**CCTV:** Abbreviation for WMATA's closed circuit television security cameras.

**CE:** Construction Engineer. The point of contact for project reviews and approvals, real estate entry permit, interface and coordination with operations and maintenance offices, and field coordination.

**CHAINMARKER:** WMATA's wayside signage displaying unit of measure and distance of the operating roadway.

**COMMERCIAL GENERAL LIABILITY INSURANCE (CGL):** An insurance policy covering the liability of the Contractor for all work or operations under or in connection with this Project; and all obligations assumed by the Contractor under this Contract.

**CONSIST:** The quantity of cars coupled together to make up a rail vehicle. See also "Revenue Train"

**CONSTRUCTION INSPECTION FACILITATOR:** Provides construction inspection coordination and oversight of Authority contractors. Ensures contractor compliance with WMATA construction plans, specifications, and regulations.

**CONSTRUCTION SEQUENCE PLAN & STAGING PLAN (includes EQUIPMENT PLAN):** A general plan to be prepared by the Owner/Developer/Contractor indicating the safe positioning of major construction equipment, particularly cranes, within the WMATA Zone of Influence, and/or crane positions, which operate with the boom encroaching or approximate to WMATA Roadway, pedestrian and vehicular access areas.

**CONTACT RAIL:** See "Third Rail".

**CONTRACTOR'S POLLUTION LEGAL LIABILITY INSURANCE (Also called: Environmental Impairment Liability):** An insurance policy covering the liability of the Contractor during the process of removal, storage, transport and disposal of hazardous waste

and contaminated soil and or asbestos abatement. The policy should also include coverage for bodily injury, and loss of, damage to, or loss of use of property, directly or indirectly arising out of the discharge, dispersal release or escape of smoke, vapors, soot, fumes, acids, alkalis, toxic chemicals, liquids, or gas, waste materials or other irritants, contaminants or pollutants into or upon the land, the atmosphere or any water course or body of water, whether it be accidental, gradual or sudden.

**COVERBOARD:** A fiberglass cover over the contact/third rail to protect personnel from accidental contact with the rail.

**CROSSLEVEL:** The relationship in altitude that the two rails of a track section have in relation to each other. Where both rails treads are of equal altitude, the track is considered as having a zero crosslevel at that point.

**CTF:** Carmen E. Turner Maintenance and Training Facility located at 3500 Pennsy Drive, Landover, MD 20785

**CUT AND COVER:** A method of constructing an underground structure, mostly tunnels, by excavating from the surface, placing the structure, and then backfilling and restoring the original surface.

**dBA:** The momentary magnitude of sound weighted to approximate the sensitivity of the human ear to certain frequencies; the dBA value describes a sound at a given instant, a maximum sound level or a steady state value.

**DESIGN AND COORDINATION CHECKLIST:** A detailed checklist provided in WMATA's Adjacent Construction Manual that provides Owners/Developers/Contractors, and Consultants with the rudiment phases of construction coordination and interface with WMATA. The list is also provided to assist Owners/Developers/Contractors, and Consultants in preparing project time schedules which are specific to WMATA impact.

**DEVELOPMENT PLAN:** A graphic representation which depicts the nature and character of the development proposed for a specific land area: information such as topography, location and size of proposed structures, location of streets trails, utilities, and storm drainage are generally included on a development plan.

**EASEMENT:** A right to or interest in property owned by another for a specific and limited purpose. Examples: access easement, utility easement, construction easement, slope easement, aerial easement, etc. Easements may be for public or private purposes.

**ENGINEER OF RECORD:** The professional engineer who develops the design criteria and concept for a particular project and discipline, and who prepares or causes to be prepared under his/her immediate personal supervision the corresponding drawings, specifications, reports, or other documents, shall be designated the engineer of record for the project and discipline.

**EMBANKMENT:** A raised structure constructed of natural soil from excavation or borrow sources.

**ENCROACHMENT:** Use of an existing easement or property without proper authorization.

**ESCORT:** A WMATA employee assigned the responsibility of ensuring contractor forces or WMATA personnel comply with the Metrorail Safety Rules and Procedures Handbook (MSRPH) and the approved Site Specific Work Plan while performing maintenance or construction in or around WMATA property. These individual or individual(s) are trained to set-up necessary protective equipment during times of authorized and approved access by Contractor personnel.

**FLAG PROTECTION:** A method of protecting revenue or non-revenue track using colored flags or radio to notify a train or work consist of a situation ahead.

**FLAGPERSON:** 1. The person assigned to ride the front of a rail vehicle while the vehicle is being operated from other than the lead end. This person acts as the operator's eyes during train movement. 2. The person in charge and who's only duty is providing flagging protection to a work area.

**FOUL TIME:** A method of Roadway protection in which all trains and/or track equipment are STOPPED. The RWIC requests ROCC to stop all traffic until the RWIC reports clear of the track. This is used only for short time periods in specific segments of track such as work areas, blind spots and no clearance zones.

**FOULING a TRACK:** The placement of an individual or equipment in such proximity to a track that the individual or equipment could be struck by a moving train or on-track equipment.

**FS:** Factor of Safety

**GENERAL ORDERS (WMATA):** WMATA's official Document that lists all of the approved track rights requests. This information is broken down by day and includes the location by track and chainmarkers, the organization(s) authorized track rights, and the type of power outage (supervisory or red tag) if required.

**GEOREFERENCE:** To define points, lines, polygons or images in a WMATA specified coordinate system. Specific reference is made to AutoCad Drawings provided to WMATA showing improvements by ODC in or around WMATA facilities.

**GEOTECHNICAL REVIEW:** An engineering study of the geology and soils of a site which is submitted to determine the suitability of a site for development and recommends construction techniques designed to overcome development on problem soils.

**GOTRS:** General Orders Track Rights System. The General Orders and Tracks Rights System is a mainframe computer program that is used by WMATA employees only, to enter requests for track rights and power outages for coordination of all wayside work and third rail power outages.

**JGB:** Jackson Graham Building. WMATA's Headquarters Building located at 600 5th Street, NW, Washington, DC 20001

**LEVEL OF SERVICE (LOS):** An estimate of the effectiveness of a roadway to carry traffic, usually under anticipated peak traffic conditions. Level of Service efficiency is generally characterized by the letters A through F, with LOS-A describing free flow traffic conditions and LOS-F describing jammed or grid-lock conditions.

**MAINLINE:** All roadway on the operating railroad, except yards and those terminals which are governed by Terminal Supervisors.

**MAINTENANCE OPERATIONS CONTROL (MOC):** The facility located at WMATA's Headquarters Building, 600 5th Street, NW, Washington, DC 20001 from which all maintenance for the system is primarily tracked and reported to.

**MONITORING AND CONTINGENCY PLAN:** A written plan designed, implemented by the Owner/Developer/Contractor that includes, but is not limited to, how the Owner/Developer/Contractor plans to provide surveillance of WMATA facilities potentially impacted by proposed construction. The plan must include criteria for threshold values or deformations, or movements. The plan shall also outline the contingency procedure that will be followed when strains, deformations or movements of WMATA facilities approach or exceed the specified limits. The plan will also contain detailed personnel contact information of both Contractor and WMATA personnel involved with implementing the monitoring program.

**MONUMENT:** A permanent WMATA survey marker/benchmark accurately defining a point from which the surrounding WMATA structures were plotted (elevation and horizontal distances).

**NO CLEARANCE AREA:** An area where the minimum safe distance between all points on a moving vehicle and fixed wayside structures or appurtenances is not sufficient to allow personnel to occupy this area during passage of a train.

**ODC:** Owner, Developer, Contractor or Consultant.

**OPERATIONAL SUPPORT:** Any support provided by WMATA's operational departments.

**RAIL OPERATIONS CONTROL CENTER (ROCC):** The center designated to control the movement of trains and other track equipment.

**PHOTOMETRIC STUDY:** A site lighting plan prepared by a registered Professional Engineer which conveys projected illumination levels, wattage levels, maintenance criteria and input values.

**PIEZOMETER OR OBSERVATION WELLS:** A drilled casing or standpipe (instrumentation) in the soil used to measure porewater pressure.

**POST-CONSTRUCTION SURVEY:** A detailed written and certified follow-up technical survey and analysis of a WMATA facility or facility(s) that were potentially impacted by ongoing construction. The post-construction survey is to be completed when all work is completed, or when construction has progressed to a construction phase whereby there is no future possibility of any movement/damage/impact to WMATA structures. The survey may be supported with comparison engineering or technical

analysis of pre-construction photographs and/or wayside instrumentation. Written analysis of the post-construction survey must also be submitted to WMATA for approval prior to the Contractor mobilizing from the site.

**PRE-CONSTRUCTION SURVEY:** A detailed written & certified technical survey & analysis of a WMATA facility or facility(s) that will potentially be impacted by upcoming construction. The survey may require the necessity of photographs and/or safe placement of wayside instrumentation for purposes of continued and periodic surveillance/protection of WMATA facilities. The outline of the pre-construction survey is to be developed by the Contractor and submitted to WMATA for approval before commencing any work within WMATA's ZOI.

**PRE-DEVELOPMENT PROJECT AGREEMENT:** A legal agreement between WMATA and the Developer/Contractor executed at the beginning of a project which documents that the Developer/Contractor agree to read and comply with all WMATA administrative, design, operational, safety requirements set forth in the WMATA Adjacent Construction Manual. No project will be supported unless this agreement is executed.

**PROFESSIONAL ERRORS AND OMISSIONS LIABILITY INSURANCE:** A separate insurance policy to pay on behalf of the Contractor all costs the Contractor shall become legally obligated to pay as damages due to any claim caused by any negligent act, error or omission of the Contractor or any other person for whose acts the Contractor is legally liable arising out of the performance of work under a permit.

**PROJECT IMPACT STATEMENT:** A statement completed by the Owner/Developer/Contractor, or Consultant which describes in detail the impact to WMATA facilities, with locations, from all upcoming proposed construction. The statement is prepared by the Owner/Developer/Contractor, or Consultant seeking work in the vicinity of WMATA facilities and requires prior review of WMATA As-built documentation.

**PROTECTED WORK AREA:** Area designated as extreme limits (chainmarker stationing) in approved SSWP within which work will be performed.

**RAIL SERVICE ADJUSTMENT (RSA):** A temporary adjustment to the Metrorail passenger train operating schedule in order to accommodate maintenance or construction activities on the Metrorail main line during revenue service.

**RAILROAD PROTECTIVE LIABILITY INSURANCE:** An insurance policy issued to WMATA for bodily injury and property damage liability of the Contractor resulting from the Contractor's performance of project work within 50 feet of WMATA's Roadway. Project work within 50 feet is defined as: work performed on, adjacent to (North-South-East-West), above or beneath WMATA's owned / operating railroad property.

**RED TAG:** A red tag outage is issued by MOC to responsible Supervisor of work area/location when a specified section(s) of third rail or electrical equipment is de-energized by physically disconnecting the specified equipment from its source of power, and is secured and verified. This outage should be used for the maintenance, repair installation and test of energized equipment. A red tag outage

must be used whenever work is done directly on the third rail or its connected equipment.

**REVENUE OPERATION (hours of):** Time(s) which WMATA runs scheduled passenger rail service.

**REVENUE TRAIN:** Assemblage of WMATA rail cars designated to carry passengers. Length of Revenue Train is typically 4, 6, or 8 cars.

**RIGHT OF ACCESS:** The right of an abutting land owner, or its contractor(s), for entrance to or exit from a WMATA facility or structure for purposes of construction or planning.

**Right-of-Way (ROW):** The land occupied by a railroad, the physical facilities, track, tunnels, surface and elevated structures through which Metrorail trains operate.

**ROADWAY:** All track on the operating railroad, except yards and those terminals which are governed by Terminal Supervisors.

**SHUNT STRAP:** A jumper, for shunting rail to rail to simulate the presence of a train axle to safely protect a work area.

**SITE SPECIFIC WORK PLAN (WMATA):** Abbreviated 'SSWP'. A detailed time scaled, resource loaded work plan prepared by the Contractor that is specific to WMATA property which describes the construction and/or installation and associated schedule of work to be performed at specific locations. The plan is to outline all personnel and work to be completed during approved track access. The plan encompasses: 1) a site plan, 2) track rights approval information, 3) a work zone protection plan, 4) identify an assigned Contractor's on site safety foreman, and 5) a detailed summary of work to be completed including work procedures and potential job related hazards with protection methods. Required where requested track usage or other interface with the operating rail road occurs.

**SURVEYOR OF RECORD:** The professional surveyor who develops the criteria and concept for a particular project and discipline, and who prepares or causes to be prepared under his/her immediate personal supervision the corresponding survey results, drawings, specifications, reports, or other documents, shall be designated the surveyor of record for the project and discipline.

**SWITCH ORDER:** Detailed set of instructions that directs WMATA's power personnel on how to isolate power circuits from a specific piece of equipment, i.e. third rail, lighting circuit, etc.

**TBS:** WMATA Tie Breaker Station. See Tiebreaker.

**TECHNICAL SUBMISSION (Submittal):** A minimum of seven (7) complete sets of documents required for WMATA review of the anticipated or proposed construction. In submitting, the Owner/Developer/Contractor or Consultant has confirmed that all documents being provided for WMATA review meet the requirements of the WMATA Adjacent Construction Manual, Design Criteria, Specifications, or specific agreement as applicable. Content of submittals to be specific to WMATA interest.

**THIRD RAIL:** The electrical conductor steel rail section mounted on insulators adjacent to the running rail for supplying D.C. traction power to the transit vehicles, sometimes referred to as “contact rail”.

**THIRD RAIL GAP:** The distance between sections of third rail where no third rail is present. These locations are usually of sufficient length to be bridged by a train and are used as a limit for either a Supervisory Third Rail Power Outage or a Red Tag Third Rail Power Outage.

**THIRD RAIL POWER:**

**RED TAG OUTAGE:** A procedure for removal of energy from the third rail which requires that track feeder breakers which feed a specific section of third rail be removed from their operating cubicles and specific verification and coordination procedures involving ROCC and MOC and the Red Tag holder. Under Third Rail Power Red Tag Outages work is permitted on the third rail and its connecting components. Red Tag outages are also used for work on Low Voltage AC power equipment and circuits.

**SUPERVISORY:** A third rail power outage that may be implemented from ROCC for work that might result in incidental contact with the third rail. Work on, or that requires contact with the third rail requires a Third Rail Power Red Tag Outage.

**TIEBREAKER:** A redundant source for traction power distribution by electrically connecting one Traction Power Substation to another by using the third rail and circuit breakers in the tiebreaker station. The tiebreaker station is also used in conjunction with the traction power substation to isolate power from a section of third rail.

**TPSS:** WMATA Traction Power Substation. See Traction Power Substation.

**TRACK RIGHTS:** Exclusive use permission for a specific section of track. Permission is requested through GOTRS, and approved by WMATA OPER, General Superintendent OCC.

**TRACTION POWER SUBSTATION:** The facility which transforms and rectifies local utility high voltage alternating current to 750 VDC propulsion current and supplies it to nearby third rails via Track Feeder Breakers and conductors to/on the R.O.W.

**WORK TRAIN:** Any vehicle designated for maintenance purposes or to transport non-public passengers. A work train is a train that is engaged in railway maintenance, repair work or support thereof.

**WAYSIDE SAFETY ALARM DEVICE:** Safety device which provides work crews with an alarm in the form of both siren and strobe light if the third rail to which it is connected becomes energized or if the device is accidentally disconnected or knocked over. Device is connected (after confirmation of a power outage) between the de-energized third rail and the negative return rail, within the work zone, by the assigned WMATA escort.



**WMATA:** All WMATA Office's that provide submittal reviews and operational support.

**WMATA REAL ESTATE IMPACT:** Temporary or permanent construction impact to WMATA's existing real property or easement(s).

**WMATA Real Estate Entry Permit:** A legal document issued by WMATA's Office of Station Area Planning and Asset Management when it has been determined that there is temporary or permanent construction impact to WMATA. Developer/Contractor(s) will be required to complete the WMATA Real estate entry permit application to obtain legal access to WMATA property or easement(s). Certified survey exhibits, plats and/or legal descriptions of property impacted may be required.

**WMATA's ZONE OF INFLUENCE (ZOI):** Designated area adjacent or within specific distance approximate to WMATA structures and interests, which if construction activity is performed within the Zone, may cause influence or impact to WMATA. Limits of Zones for various conditions of adjacency are depicted in [Appendix 3](#), Plates 2A thru 2E.