



U.S. Department of  
Transportation

**Federal Railroad  
Administration**

# **Hazards Associated with HSR Operations Adjacent to Conventional Tracks – Enhanced Literature Review Part III: Literature Review**

---

Office of Research,  
Development  
and Technology  
Washington, DC 20590



#### NOTICE

This document is disseminated under the sponsorship of the Department of Transportation in the interest of information exchange. The United States Government assumes no liability for its contents or use thereof. Any opinions, findings and conclusions, or recommendations expressed in this material do not necessarily reflect the views or policies of the United States Government, nor does mention of trade names, commercial products, or organizations imply endorsement by the United States Government. The United States Government assumes no liability for the content or use of the material contained in this document.

#### NOTICE

The United States Government does not endorse products or manufacturers. Trade or manufacturers' names appear herein solely because they are considered essential to the objective of this report.

<b>REPORT DOCUMENTATION PAGE</b>			<i>Form Approved</i> <i>OMB No. 0704-0188</i>	
Public reporting burden for this collection of information is estimated to average 1 hour per response, including the time for reviewing instructions, searching existing data sources, gathering and maintaining the data needed, and completing and reviewing the collection of information. Send comments regarding this burden estimate or any other aspect of this collection of information, including suggestions for reducing this burden, to Washington Headquarters Services, Directorate for Information Operations and Reports, 1215 Jefferson Davis Highway, Suite 1204, Arlington, VA 22202-4302, and to the Office of Management and Budget, Paperwork Reduction Project (0704-0188), Washington, DC 20503.				
1. AGENCY USE ONLY (Leave blank)		2. REPORT DATE August 2019		3. REPORT TYPE AND DATES COVERED Technical Report April 1 2014 – June 21, 2014
4. TITLE AND SUBTITLE Hazards Associated with HSR Operations Adjacent to Conventional Tracks – Enhanced Literature Review Part III: Literature Review			5. FUNDING NUMBERS DTFR53-12-D-00002 Task Order 2	
6. AUTHOR(S) Mohd Rapik Saat and Christopher P.L. Barkan				
7. PERFORMING ORGANIZATION NAME(S) AND ADDRESS(ES) University of Illinois at Urbana-Champaign Rail Transportation and Engineering Center – RailTEC Department of Civil and Environmental Engineering 205 N. Mathews Ave Urbana, IL 61801			8. PERFORMING ORGANIZATION REPORT NUMBER	
9. SPONSORING/MONITORING AGENCY NAME(S) AND ADDRESS(ES) U.S. Department of Transportation Federal Railroad Administration Office of Railroad Policy and Development Office of Research, Development and Technology Washington, DC 20590			10. SPONSORING/MONITORING AGENCY REPORT NUMBER  DOT/FRA/ORD-19/29	
11. SUPPLEMENTARY NOTES COR: Francesco Bedini Jacobini				
12a. DISTRIBUTION/AVAILABILITY STATEMENT This document is available to the public through the FRA <a href="#">website</a> .			12b. DISTRIBUTION CODE	
13. ABSTRACT (Maximum 200 words) The Federal Railroad Administration (FRA) set out to develop a best practices document which provides information on the design considerations and potential risk mitigations for high-speed rail (HSR) systems adjacent to and sharing corridors with existing conventional railway operations. The objective of this project is to provide input to and support the development of the best practices document by conducting a comprehensive literature review of the 11 hazards associated with HSR operations adjacent to conventional tracks that were identified by the FRA. This report is the third part of the three-part project that consists of two parts. The first part presents a comprehensive literature review of the 11 hazards and other miscellaneous studies associated with HSR operations adjacent to conventional tracks. The second part of this report presents the prioritization of the importance of the hazards and the identification of potential strategies to mitigate the effects of the high-priority hazards.				
14. SUBJECT TERMS  Shared corridors, high speed rail, conventional railroad			15. NUMBER OF PAGES 78	
			16. PRICE CODE	
17. SECURITY CLASSIFICATION OF REPORT Unclassified	18. SECURITY CLASSIFICATION OF THIS PAGE Unclassified	19. SECURITY CLASSIFICATION OF ABSTRACT Unclassified	20. LIMITATION OF ABSTRACT	

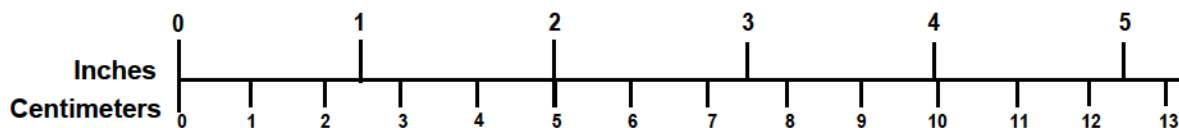
## METRIC/ENGLISH CONVERSION FACTORS

### ENGLISH TO METRIC

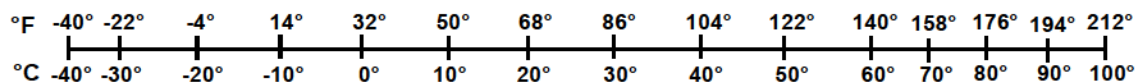
### METRIC TO ENGLISH

<p style="text-align: center;"><b>LENGTH (APPROXIMATE)</b></p> <p>1 inch (in) = 2.5 centimeters (cm)</p> <p>1 foot (ft) = 30 centimeters (cm)</p> <p>1 yard (yd) = 0.9 meter (m)</p> <p>1 mile (mi) = 1.6 kilometers (km)</p>	<p style="text-align: center;"><b>LENGTH (APPROXIMATE)</b></p> <p>1 millimeter (mm) = 0.04 inch (in)</p> <p>1 centimeter (cm) = 0.4 inch (in)</p> <p>1 meter (m) = 3.3 feet (ft)</p> <p>1 meter (m) = 1.1 yards (yd)</p> <p>1 kilometer (km) = 0.6 mile (mi)</p>
<p style="text-align: center;"><b>AREA (APPROXIMATE)</b></p> <p>1 square inch (sq in, in<sup>2</sup>) = 6.5 square centimeters (cm<sup>2</sup>)</p> <p>1 square foot (sq ft, ft<sup>2</sup>) = 0.09 square meter (m<sup>2</sup>)</p> <p>1 square yard (sq yd, yd<sup>2</sup>) = 0.8 square meter (m<sup>2</sup>)</p> <p>1 square mile (sq mi, mi<sup>2</sup>) = 2.6 square kilometers (km<sup>2</sup>)</p> <p>1 acre = 0.4 hectare (ha) = 4,000 square meters (m<sup>2</sup>)</p>	<p style="text-align: center;"><b>AREA (APPROXIMATE)</b></p> <p>1 square centimeter (cm<sup>2</sup>) = 0.16 square inch (sq in, in<sup>2</sup>)</p> <p>1 square meter (m<sup>2</sup>) = 1.2 square yards (sq yd, yd<sup>2</sup>)</p> <p>1 square kilometer (km<sup>2</sup>) = 0.4 square mile (sq mi, mi<sup>2</sup>)</p> <p>10,000 square meters (m<sup>2</sup>) = 1 hectare (ha) = 2.5 acres</p>
<p style="text-align: center;"><b>MASS - WEIGHT (APPROXIMATE)</b></p> <p>1 ounce (oz) = 28 grams (gm)</p> <p>1 pound (lb) = 0.45 kilogram (kg)</p> <p>1 short ton = 2,000 pounds (lb) = 0.9 tonne (t)</p>	<p style="text-align: center;"><b>MASS - WEIGHT (APPROXIMATE)</b></p> <p>1 gram (gm) = 0.036 ounce (oz)</p> <p>1 kilogram (kg) = 2.2 pounds (lb)</p> <p>1 tonne (t) = 1,000 kilograms (kg)</p> <p style="text-align: right;">= 1.1 short tons</p>
<p style="text-align: center;"><b>VOLUME (APPROXIMATE)</b></p> <p>1 teaspoon (tsp) = 5 milliliters (ml)</p> <p>1 tablespoon (tbsp) = 15 milliliters (ml)</p> <p>1 fluid ounce (fl oz) = 30 milliliters (ml)</p> <p>1 cup (c) = 0.24 liter (l)</p> <p>1 pint (pt) = 0.47 liter (l)</p> <p>1 quart (qt) = 0.96 liter (l)</p> <p>1 gallon (gal) = 3.8 liters (l)</p> <p>1 cubic foot (cu ft, ft<sup>3</sup>) = 0.03 cubic meter (m<sup>3</sup>)</p> <p>1 cubic yard (cu yd, yd<sup>3</sup>) = 0.76 cubic meter (m<sup>3</sup>)</p>	<p style="text-align: center;"><b>VOLUME (APPROXIMATE)</b></p> <p>1 milliliter (ml) = 0.03 fluid ounce (fl oz)</p> <p>1 liter (l) = 2.1 pints (pt)</p> <p>1 liter (l) = 1.06 quarts (qt)</p> <p>1 liter (l) = 0.26 gallon (gal)</p> <p>1 cubic meter (m<sup>3</sup>) = 36 cubic feet (cu ft, ft<sup>3</sup>)</p> <p>1 cubic meter (m<sup>3</sup>) = 1.3 cubic yards (cu yd, yd<sup>3</sup>)</p>
<p style="text-align: center;"><b>TEMPERATURE (EXACT)</b></p> <p style="text-align: center;">[(x-32)(5/9)] °F = y °C</p>	<p style="text-align: center;"><b>TEMPERATURE (EXACT)</b></p> <p style="text-align: center;">[(9/5)y + 32] °C = x °F</p>

### QUICK INCH - CENTIMETER LENGTH CONVERSION



### QUICK FAHRENHEIT - CELSIUS TEMPERATURE CONVERSION



For more exact and or other conversion factors, see NIST Miscellaneous Publication 286, Units of Weights and Measures. Price \$2.50 SD Catalog No. C13 10286

Updated 6/17/98

# Contents

---

Executive Summary .....	7
1. Introduction .....	9
1.1 Background .....	9
1.2 Objectives .....	9
1.3 Overall Approach .....	10
1.4 Scope .....	10
1.5 Organization of the Report .....	10
2. Literature Review .....	11
2.1 Relevant Major Research Programs .....	11
2.2 Derailment on Adjacent Tracks.....	12
2.3 Shifted Load on an Adjacent Track.....	21
2.4 Aerodynamic Interaction between Trains on Adjacent Tracks.....	21
2.5 Ground-Borne Vibration and Its Effect on HSR Track Geometry.....	35
2.6 Intrusion of Maintenance-of-Way Staff and Equipment Working on the Adjacent Track.....	37
2.7 Obstruction Hazard Resulting from an Adjacent Track (Non-Derailment and Grade-Crossing Collisions) .....	40
2.8 Drainage Problem Affecting Either the HSR Track or the Adjacent Track.....	42
2.9 Hazardous Materials on the Adjacent Track .....	43
2.10 Fire on the Adjacent Track .....	44
2.11 Evacuation of Passengers on the Adjacent Track .....	45
2.12 Electromagnetic Interference between Trains and Wayside Equipment on Adjacent Tracks .....	48
3. Hazard Prioritization and Mitigation Strategies .....	50
3.1 Introduction .....	50
3.2 Hazard Prioritization .....	50
3.3 Potential Risk Mitigation Strategies.....	51
4. Conclusion.....	59
5. References .....	60
Appendix A. Example International Railway Speed Incremental Project–China’s Experience .	69
Abbreviations and Acronyms .....	75

## Illustrations

---

Figure 2.1 Maximum lateral travel distribution (English et al., 2007) .....	14
Figure 2.2 Derived lateral dispersion probability distribution (English et al., 2007) .....	15
Figure 2.3 Cumulative derived lateral distribution vs NTSB (81-85) data (English et al., 2007) 16	
Figure 2.4 Conceptual framework for adjacent track accident (Lin & Saat, 2014).....	19
Figure 2.5 Mesh surfaces and schematic of trains with axle numbering system.....	22
Figure 2.6 Time histories of the (a) Aerodynamic forces and (b) Aerodynamic moments acting on the container car for Case 1 (Holmes et al., 2000).....	24
Figure 2.7 Time histories of the (a) Roll motions (b) Yaw motions, and (c) Wheel loads on the container car for Case 8 (Holmes et al., 2000) .....	25
Figure 2.8 Schematic picture and the computational grid of the train (Fujii & Ogawa, 1995) ....	26
Figure 2.9 Time history of the pressure coefficient on the side-wall surface facing to the opposite train; the broken lines indicate the time when the front and rear noses of the opposite train pass the longitudinal center (Fujii & Ogawa, 1995).....	26
Figure 2.10 Time history of the aerodynamic loads on the train (a) Drag coefficient (b) Side force coefficient (c) Lift coefficient (d) Yawing moment coefficient (e) Pitching moment coefficient (f) Rolling moment (Fujii & Ogawa, 1995).....	27
Figure 2.11 Model train configuration (Raghunathan et al., 2002) .....	28
Figure 2.12 The rig for pressure variation measurement (Raghunathan et al., 2002) .....	29
Figure 2.13 Effect of train head on (left) and tail on (right) pressure variation (Raghunathan et al., 2002) .....	30
Figure 2.14 Pressure variations occurring when two trains pass each other (Raghunathan et al., 2002) .....	31
Figure 2.15 Schematic diagram of two trains pass each other under crosswind condition with two kinds of track separation (Li et al., 2011) .....	32
Figure 2.16 Response of lateral acceleration of the train (Li et al., 2011).....	32
Figure 2.17 Schematic diagram of testing train on leeward (downwind) rail track (track C) of the crosswind when two trains pass each other (Li et al., 2013) .....	34
Figure 2.18 Time histories of train's (a) drag coefficients (b) lift coefficient and (c) moment coefficients when the testing train is on the leeward track (Li et al., 2013) .....	34
Figure 2.19 Ground vibration spectra (dB reference 10-9 m/s) generated by a train of five cars moving at sub-Rayleigh and trans-Rayleigh speeds. (Krylov, 1995) .....	36
Figure 2.20 Effect of soil attenuation constant $\gamma$ on ground vibration level (dB reference 10-9 m/s) generated by a train of five cars moving at three trans-Rayleigh speeds: 50 km/h (Vz1), 150 km/h (Vz2), and 250 km/h (Vz3). (Krylov, 1996).....	36
Figure 2.21 Graphical Examples of current on-track safety procedures for certain roadway work groups and adjacent tracks (FRA, 2014).....	40

Figure 2.22 Drainage design on HSR track under shared rail corridor setting.....	43
Figure 2.23 Sequence of events leading to a hazardous materials release incident.....	44
Figure 2.24 Emergency Evacuation Simulator (Rollover Rig) (FRA, 2006) .....	47
Figure 3.1 The installation of the intrusion detection system (Abtahi, 2013) .....	52
Figure 3.2 Earthwork barrier protection (Abtahi, 2013).....	53
Figure 3.3 Structural barrier protection (Abtahi, 2013).....	53
Figure 3.4 Guard rail protection (Abtahi, 2013).....	54
Figure 3.5 Parapet protection (Abtahi, 2013) .....	55
Figure 3.6 Undercar guard protection (Abtahi, 2013) .....	55
Figure 3.7 An upgraded grade-crossing with four-quadrant gates, train approaching warning devices, and traffic channelization devices (Bien-Aime, 2009) .....	56

## Tables

---

Table 2.1 Site-specific characteristic rating table (Cockle, 2014) .....	17
Table 2.2 Relative hazard frequency assessment and classification (Cockle, 2014).....	18
Table 2.3 Risk assessment matrix and acceptance matrix (Cockle, 2014) .....	18
Table 2.4 Summary of intrusion factor score and level of intrusion rate (Lin & Saat, 2014) .....	20
Table 2.5 Simulation case analysis matrix (Holmes et al., 2000).....	23
Table 2.6 Response of acceleration of train at various train speeds (Li et al., 2011) .....	33
Table 2.7 Acceleration of train under different crosswind speed when the space between two trains are (a) 3.5 meters apart and (b) 29.5 meters apart. (Li et al., 2011).....	33
Table 2.8 Summary of current on-track safety procedures for certain roadway work groups and adjacent tracks (FRA, 2014) .....	39
Table 2.9 Summary of Federal regulation related to grade crossing protection and closure (FRA, 2012) .....	41
Table 2.10 Comparison of passenger rail car evacuation flow rates (FRA, 2013).....	46



## Executive Summary

---

The Federal Railroad Administration (FRA) sponsored Booz Allen Hamilton (Booz Allen) and the Rail Transportation and Engineering Center (RailTEC) in the Department of Civil and Environmental Engineering at the University of Illinois at Urbana-Champaign (UIUC) to assist in the development of a best practices document which provides information on the design considerations and potential risk mitigations for high-speed rail (HSR) systems adjacent to and sharing corridors with existing conventional railway operations. Research and testing took place from April through June 2014. With the increasing demand for HSR operations, the potential hazards between HSR tracks and adjacent conventional tracks became more pronounced and needed to be considered. The objective of this project was to provide input to and support the development of the best practices document by conducting a comprehensive literature review of the following hazards associated with HSR operations adjacent to conventional tracks:

- Derailment on adjacent tracks
- Shifted load on adjacent tracks
- Aerodynamic interaction between trains on adjacent tracks
- Ground-borne vibration and its effect on HSR track geometry
- Intrusion of maintenance-of-way staff and equipment working on the adjacent track
- Obstruction hazard resulting from an adjacent track (non-derailment and grade-crossing collisions)
- Drainage problem affecting either the HSR track or the adjacent track
- Evacuation of passengers from trains on the adjacent track
- Hazardous materials on the adjacent track
- Fire on the adjacent track
- Electromagnetic interference between trains and wayside equipment on adjacent tracks

The initial literature review was enhanced by an additional, detailed literature review on specific hazards that FRA deems as requiring more information as well as train accident analyses to identify train accident causes that are relevant to shared corridor operations. Booz Allen and RailTEC then developed a draft best practices document based on the enhanced literature review and additional risk analyses. The entire project consists of three parts: (1) A summary report that defines the scope of the literature review and summarizes the results from the comprehensive literature review; (2) A draft best practices document for understanding, addressing and mitigating the risk of HSR systems adjacent to and sharing corridors with existing conventional railway operations using qualitative and quantitative risk management approaches; and (3) A complete and enhanced literature review of mitigating the risk of HSR systems adjacent to and sharing corridors with existing conventional railway operations.

This report presents Part III of the project, consisting of two parts. The first part presents a comprehensive literature review of the aforementioned hazards and other miscellaneous studies associated with HSR operations adjacent to conventional tracks, and efforts in collecting and sorting out (in clear and organized manner) all information related to the aforementioned hazards and its relevance to the subject matter. The Part II of this report presents the prioritization of the importance of the hazards, and the identification of potential strategies to mitigate the effects of the high-priority hazards. In the future, quantitative analyses are expected to be conducted to

evaluate and mitigate the risk of these hazards to support the development of the best practices document.

# 1. Introduction

---

This section provides the background and motivation of the literature review. Eleven potential hazards on shared corridor are identified and the scope and the methodology used are presented. A brief summary of each following sections is provided.

## 1.1 Background

With the increasing demand for high-speed rail (HSR) operations, the potential hazards between HSR tracks and adjacent conventional tracks became more pronounced and needed to be considered. The Federal Railroad Administration (FRA) set out to develop a best practices document which provides information on the design considerations and potential risk mitigations for HSR systems adjacent to, and sharing corridors with, existing conventional railway operations. The document combines existing and proposed research to aid in the proposal, design, and evaluation of planned HSR alignments, particularly in areas where several conventional freight and passenger operations are in service within the same corridor (e.g., Northeast Corridor). The hazards identified in this report include those that pose potential risk to HSR operations due to adjacent conventional railroad operations and those that pose potential risk to conventional railroad operations due to adjacent HSR operations. The development of the document and its final contents consider the following issues:

- Minimum track and right-of-way (ROW) spacing from adjacent railroad tracks without the use of additional protection
- Use of intrusion detection or protection devices and proper system characteristics and installation locations
- Use of physical barriers or crash walls; what conditions warrant use and basic design characteristics
- Other relevant considerations such as aerodynamics, effects of grading and track heights, and protection from activities along ROWs, etc.

## 1.2 Objectives

Researchers sought to provide input to and support the development of the best practices document by conducting a comprehensive literature review of the following hazards associated with HSR operations adjacent to conventional tracks:

- Derailment on adjacent tracks
- Shifted load on adjacent tracks
- Aerodynamic interaction between trains on adjacent tracks
- Ground borne vibration and its effect on HSR track geometry
- Intrusion of maintenance of way staff and equipment working on the adjacent track
- Obstruction hazard resulting from an adjacent track (non-derailment and grade-crossing collisions)
- Drainage problem affecting either the HSR track or the adjacent track
- Evacuation of passengers from trains on the adjacent track
- Hazardous materials on the adjacent track
- Fire on the adjacent track

- Electromagnetic interference between trains and wayside equipment on adjacent tracks

### **1.3 Overall Approach**

Researchers found relevant published material for this literature review. They reviewed the reference section of each paper and other potentially relevant papers. And they selected for more detailed analysis studies that contributed to a better understanding of each of the five hazards, especially those pertaining to shared-use rail corridor operations.

### **1.4 Scope**

This research focused on collecting and analyzing literature related to the safety issues of operating HSR adjacent to conventional railroad corridors. Researchers did not include literature related to safety issues of general railroads or individual railroad.

### **1.5 Organization of the Report**

Section 2 presents the result of literature review. Section 3 presents the result of risk prioritization and proposed risk mitigation strategies. Section 4 presents conclusions based on the literature review. [Appendix A](#) presents the infrastructure and system improvements as a result of implementing shared corridor in China.

## 2. Literature Review

---

Each subsection presents the literature review of a potential shared corridor hazard. Methodologies and technologies covered for addressing these hazards are summarized and areas that have not been address yet are discussed.

### 2.1 Relevant Major Research Programs

Congressional interest in HSR dates back to 1965, with passage of the High Speed Ground Transportation Act. After a short hiatus between 1975 and 1980, Congress refocused on HSR with the passing of the Passenger Railroad Rebuilding Act of 1980, which selected several corridors for HSR feasibility studies. Later in the 1980s, Congress considered magnetic levitation (Maglev) technology as a possible way of achieving high-speed transportation in the U.S. Thereafter, “high-speed guided ground transportation (HSGGT)” was used to represent both high-speed rail and the maglev systems. In 1988, the extended Federal Railroad Safety Act included the HSGGT in its definition of “railroad.”

Starting in the 1990s, various research and analyes investigated and addressed safety issues of the operation of new HSGGT systems. Bing (1990) identified safety issues and research needs for HSGGT systems. Passenger car structural strength, brake system performance, security of the ROW against obstructions, adjacent track accidents, and high-speed signaling and train control systems were the major issues identified.

Hadden et al. (1993) developed a methodology to assess the potential risks associated with an HSGGT system sharing the same ROW with another mode of transportation (e.g., conventional railway, mass transit, pipeline). The purpose of the Hadden et al. analysis was similar to that of this report. Six safety issues associated with sharing ROWs were identified:

1. Physical infringement of vehicles or structures
2. Electromagnetic field (EMF) effects
3. Dynamic interference
4. Infringement of operating envelope involving common trackage
5. Contact with hazardous materials
6. Accessibility of HSGGT vehicles or guideways for inspection, emergency access, evacuation, and trespassers

Note that all the six safety issues will also be discussed in this report; it will also focus on the operation of HSR adjacent to conventional railways. Derailment on adjacent tracks and grade-crossing accidents were parts of the discussed scenarios.

Research (Bing, 1993a, 1993b) (Harrison et al., 1993) (Galganski, 1993) on the potential collision of a HSGGT vehicle with another train or objects have been conducted. Collectively, they considered a wide range of train collision scenarios and conducted a comprehensive literature review and risk analyses for those collision scenarios. Two of the hazards in this research were included in the collision scenarios: the collision between a high-speed train and another train on adjacent tracks as well as grade-crossing collisions. Collision avoidance and collision survivability were discussed and analyzed to address the risk of various collision scenarios. Fences and/or barriers between the tracks and intrusion detection systems were recommended as potential risk mitigation strategies.

Ullman and Bing (1994) conducted an analysis of the impacts on safety and operation of introducing HSR service on or adjacent to conventional railway corridors. The effects of train braking performance, signaling systems, and train control systems were reviewed. The analysis established a safety performance target and reviewed the need for and benefits from safety improvements for high-speed operation.

Nash (2003) reviewed HSR systems around the world and identified infrastructure and operating strategies used by European railroads to improve operation of shared-use HSR in the U.S. The author suggested two potential solutions to address the safety of the shared use of high-speed and conventional trains: time separation and comprehensive risk analysis. The former is simple but may limit the flexibility and efficiency of the use of the infrastructure and system operation. The latter considers route attributes, train control systems, operating patterns, and vehicle design for all vehicles operating at a given time to develop a safe and effective shared-use system.

Saat and Barkan (2013) identified several technical and institutional challenges related to shared HSR and conventional railway corridors. Several safety issues identified in their report include: adjacent track derailments, highway grade crossings, trespassing, loss of shunt and risk to maintenance-of-way, and train operating employees.

Outside the United States, railway systems in other countries also encounter safety issues in shared-use rail corridors (SRC). China, for instance, underwent six major speed upgrades for passenger and freight trains from 1997 to 2007. Additional information about the speed upgrades in China is presented in Appendix A. France, Germany, and Sweden also have SRCs between HSR trains and conventional trains. However, limited analyses and research were conducted for the risk assessment of SRC safety.

## **2.2 Derailment on Adjacent Tracks**

Derailment on adjacent tracks, or an adjacent track accident, were identified as one of the most important safety concerns in the implementation of SRCs (Saat & Barkan, 2013). A derailment on adjacent tracks may result in the intrusion of derailed equipment or lading onto adjacent tracks, which may then lead to a collision between the derailment debris and the train on the adjacent track. There were several severe adjacent track accidents that resulted in large numbers of casualties or lading loss, and some of them involved different train types, such as freight and transit systems (National Traffic Safety Board, 1987). An adjacent track accident occurred in 2007 in Denver, CO, where a coal freight train derailed and the coal from the freight cars fouled an adjacent light rail track which was struck by a light rail vehicle, causing it to derail as well.

With the higher speed of high-speed trains (HST), the consequence of a HST colliding with derailed equipment on conventional tracks could be much greater than at lower speed. Also, the higher speed increases the probability of a collision because it might be more difficult, under some circumstances, to stop a train before striking the fouling debris.

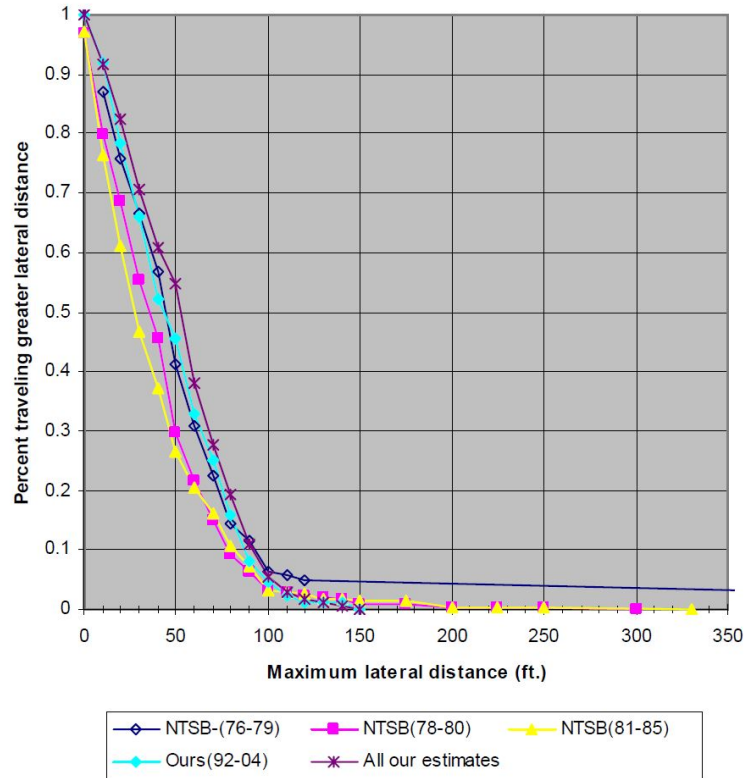
An adjacent track accident consists of a series of events: the initial train derailment (an HST or a conventional train), the intrusion of the derailed train to the adjacent track, and the presence of another train on the adjacent track (Lin & Saat, 2014). This section reviews previous research on initial train derailment probability and intrusion probability after the initial derailment.

Using analyses of accident frequency and rail traffic volume, Nayak et al. (1983) found a strong statistical correlation between FRA track class and freight train derailment rate. Anderson and

Barkan (2004) used new data to develop updated estimates. Both studies found that higher FRA track classes had lower freight train derailment rates, varying by more than an order of magnitude. Liu et al. (2012) updated the mainline freight train derailment rate with the latest FRA accident data. Various factors were also investigated with regard to their effects on freight train derailment rates. In terms of accident cause, Dick et al. (2003) and Barkan et al. (2003) found that broken rails have a high frequency and high severity in freight train derailments, further verified by Liu et al. (2011, 2012). Schafer and Barkan (2008) investigated the effect of train length on the derailment rate. By increasing the average train length, the probability of derailment for individual trains increases, whereas the total expected number of derailments decreases.

Lin et al. (2013) conducted a causal analysis on the mainline passenger train accident rate and severity and the relevant factors (such as accident cause and train speed) by analyzing the FRA train accident database. The result showed that derailments and collisions were identified as the most potentially significant train accident types, while human factors accidents and track failures were the primary causes of those accidents. Some accident causes related to human factors on train operations were identified as high risk, such as a train speed violation and not obeying signals. Some high-risk infrastructure-related factors include track geometry defects and broken rails or welds.

As for the train intrusion rate, English et al. (2007) conducted a quantitative analysis on lateral and longitudinal displacement of derailed rolling stock based on the dispersion data from previous train derailments and collisions. The sources of accident data include the National Transportation Safety Board (NTSB) accident database, the Transportation Safety Board of Canada accident database, the FRA Rail Equipment Accident database, and media reports. [Figure 2.1](#) shows the maximum lateral travel distribution of derailed rolling stock. Different lines represent different time periods of accident data. On average, about 10 percent of the accidents had a maximum lateral displacement of 80 to 90 feet.



**Figure 2.1 Maximum lateral travel distribution (English et al., 2007)**

Based on dispersion data for mainline derailments from 1981 to 1985 in the NTSB dataset, the relationship between the maximum lateral distance traveled by derailed rolling stock and the train speed was developed by English et al. as follows:

$$P(D) = \frac{1}{\beta^\alpha \times \Gamma(\alpha)} \times D^{\alpha-1} \times e^{-\frac{D}{\beta}}$$

Where:

P(D) is the probability that the maximum lateral distance traveled by derailed rail car is D ft.

D = maximum dispersion

Γ = gamma function

β = scale parameter of the distribution.

α = shape by the parameter of the distribution

According to the properties of Gamma function,



$$\alpha = \frac{\mu^2}{\sigma^2}$$

$$\beta = \frac{\sigma^2}{\mu}$$

Where:

$\mu$  = mean of maximum lateral travel (ft.)

$\sigma$  = standard deviation of lateral travel (ft.)

Based on regression analysis, researchers found that the mean and standard deviation of the maximum lateral distance traveled by a derailed rail car is affected by the speed when the car derailed:

$$\mu = 30.7 + 0.29 V$$

$$\sigma = 0.00116 V^2 + 0.2736 V + 15.964$$

Where:

$V$  = derailment speed (mph)

Figure 2.2 shows the resulting probability distribution for the maximum distance traveled of derailed equipment for three different speeds, and Figure 2.3 shows the resulting probability distribution of exceeding a specified lateral travel distance.

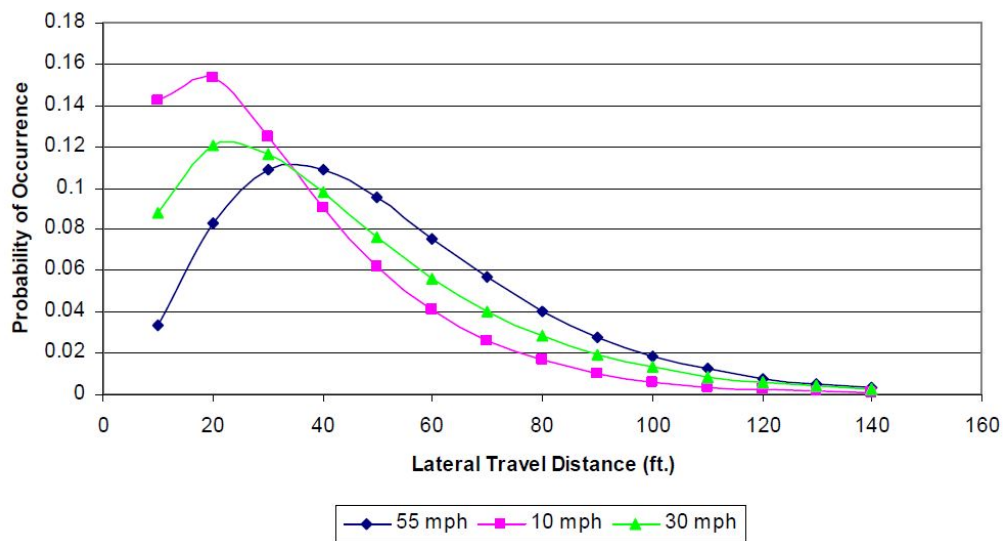
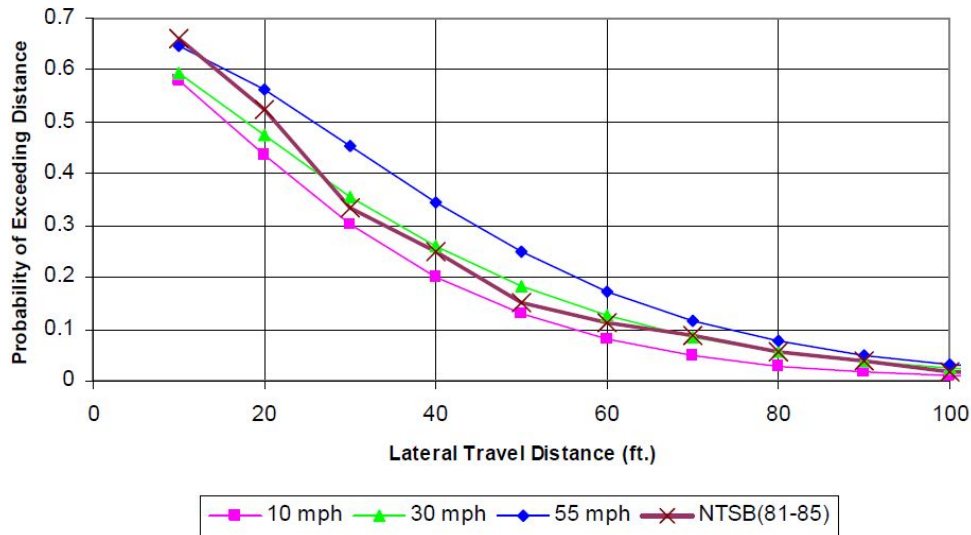


Figure 2.2 Derived lateral dispersion probability distribution (English et al., 2007)



**Figure 2.3 Cumulative derived lateral distribution vs NTSB (81–85) data (English et al., 2007)**

Cockle (2014) developed a semi-quantitative risk model, the adjacent railroad hazard risk assessment model (ARHRAM), to assess the risk associated with operating California HST adjacent to conventional railroad tracks. FRA accident data was used to determine the derailment frequency from a conventional railroad track adjacent to a HST track at a specific location, resulting in the site-specific derailment frequency (SSDF). A review of characteristics at the particular location was then conducted by considering 16 factors that may affect either the likelihood of derailment on the conventional track or the likelihood of the intrusion by derailed rolling stock from conventional track to the HST track, given a derailment. The consequence of the accident was not affected by those factors in this model. This was because under high speed operation, it was assumed that whenever a collision occurred, the consequences would be catastrophic regardless of site-specific characteristics. The 16 factors were classified into three categories: causation factors, effect factors, and nullifying factors, as shown in Table 2.1. Each factor was assigned a score according to the site-specific characteristics of the particular location. All the scores were multiplied together and then be multiplied by the SSDF. The result was the relative hazard frequency assessment (RHFA), a site-specific hazard risk index that resulted from the risk assessment matrix. The higher the RHFA index, the higher the risk. RHFA was a numerical value that allowed the California High-Speed Rail Authority (CHSRA) to compare the risks that conventional railroads pose to HST tracks at different locations and thus prioritize resources in order to reduce the high risk to an acceptable level.

**Table 2.1 Site-specific characteristic rating table (Cockle, 2014)**

<b>Category</b>	<b>Condition</b>	<b>Value</b>
<b>Causation Factors</b>		
<i>Horizontal Alignment</i>	Tangent	0
	Horizontal Curve	.1
<i>Vertical Alignment</i>	Grade < 1%	0
	Vertical Curve or Grade >= 1%	.1
<i>Type of Movement</i>	Through movement, no stops	0
	Speed change or routine stopping point	.1
	Yard/industrial switching	.3
<i>Special Trackwork</i>	None	0
	Single	.1
	Multiple	.2
<i>Movement Authorization</i>	Timetable/Special Instruction only	0
	Block Signal System	-.1
	Positive Train Control	-.5
<i>Access to Right-of-Way</i>	Open, no controls	0
	Access-control barrier	-.1
<i>Highway-Rail Grade Crossing</i>	None	0
	Private	.1
	Public	.3
<i>Train Defect Detectors</i>	None	0
	Standard train defect detector within 5 miles	-.1
	WILD w/in 50 mi	-.2
<b>Effect Factors</b>		
<i>Horizontal Alignment</i>	Tangent	0
	CHSTS on inside of curve	-.2
	CHSTS on outside of curve	.2
<i>Speed</i>	Less than 20 mph	0
	Between 21 and 40 mph	.1
	Greater than 40 mph	.2
<i>Horizontal Distance</i>	Greater than 102 feet	0
	102 feet to 86 feet	.1
	85 feet to 59 feet	.3
	Less than 59 feet	.6
<i>Elevation</i>	At-grade	0
	Elevated greater than 10 feet	.4
	Below-grade greater than 10 feet	-.4
<i>Adjacent Structure</i>	None	0
	Deflects derailment toward CHSTS	.1
	Mitigates derailment per TM 2.1.7 criteria	-.7
<i>Overhead Structure</i>	None, or protected	0
	Unprotected overhead structure	.2
<b>Nullifying Factors</b>		
<i>Horizontal Distance</i>	125 feet or greater	0
	Less than 125 feet	1
<i>Horizontal/Vertical Sep.</i>	Horizontal separation > 25 feet <u>and</u> Vertical separation > 10 feet	0
	Other than above	1

Table 2.2 shows the classification of RHFA and Table 2.3 shows the risk assessment matrix. Please note that because of the consequences of all collisions between HSTs and freight trains was assumed to be catastrophic, only the second column of the risk assessment matrix was used. Table 2.3 also shows the risk acceptance matrix that set the criteria for CHSRA to determine whether the risk at a specific location was acceptable.

**Table 2.2 Relative hazard frequency assessment and classification (Cockle, 2014)**

RHFA	Classification
RHFA > 110	Occasional
110 => RHFA => 90	Remote
90 > RHFA	Highly Unlikely

**Table 2.3 Risk assessment matrix and acceptance matrix (Cockle, 2014)**

**Risk Assessment Matrix**

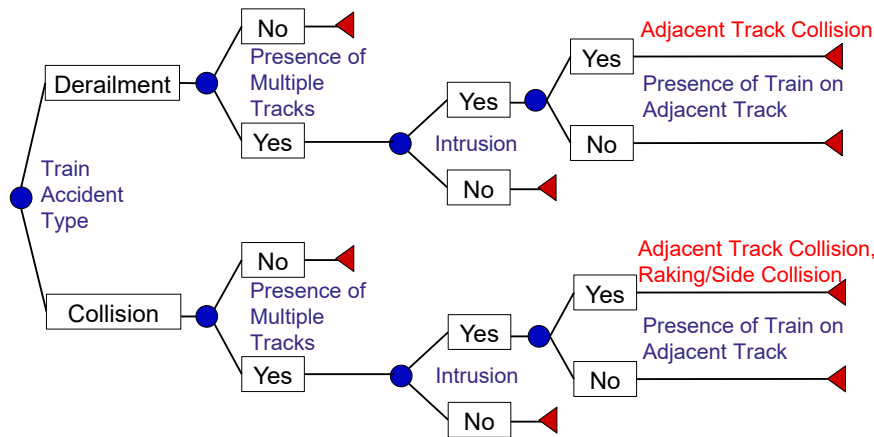
Probability \ Severity	1 Catastrophic	2 Critical	3 Marginal	4 Negligible
(A) Frequent	1A	2A	3A	4A
(B) Probable	1B	2B	3B	4B
(C) Occasional	1C	2C	3C	4C
(D) Remote	1D	2D	3D	4D
(E) Highly unlikely	1E	2E	3E	4E
(F) Eliminated				

The Risk Acceptance Matrix identifies required actions to reduce risk based on the risk rating. The Authority will accept the residual risk through the Safety and Security Executive Committee (SSEC) process where appropriate; direct approval of individual risk acceptance decisions for hazard risks categorized as *Undesirable*, or review and approval of hazard analysis reports for hazard risks categorized as *Tolerable*. Hazard risks categorized as *Acceptable* do not require SSEC review and approval.

**Risk Acceptance Matrix**

Hazard Risk Index	Risk Rating	Action Required
1A, 1B, 1C, 2A, 2B, 3A	Unacceptable	Risk must be reduced and managed
1D, 2C, 3B, 4A	Undesirable	Risk is acceptable only where further risk reduction is impracticable. Authority decision required to accept residual risk
1E, 2D, 2E, 3C, 3D, 4B, 4C	Tolerable	Apply mitigations where reasonably practicable. Risk can be tolerated and accepted with adequate controls. Authority review required to accept residual risk
3E, 4D, 4E	Acceptable	No further risk reduction required
	Eliminated	None

Lin and Saat (2014) conducted a general and comprehensive risk assessment to identify factors affecting the likelihood and consequences of adjacent track accidents where a derailed rolling stock fouled the adjacent track. A discussion on how these factors affect the probability and consequences was provided. The authors developed a semi-quantitative risk analysis model to evaluate the adjacent track accident risk, incorporating various factors affecting train accident rate, intrusion rate, train presence probability, and accident consequences. Figure 2.4 shows the conceptual framework of adjacent track accident risk assessment. The adjacent track accident was divided into a series of events: the initial accident (derailment or collision), the intrusion of derailed equipment, and the presence of another train on the adjacent track. The probabilities of each event were evaluated, as were the consequences of the accident.



**Figure 2.4 Conceptual framework for adjacent track accident (Lin & Saat, 2014)**

Similar to Cockle’s model, Lin and Saat’s model was affected by various factors. For a specific track segment of interest, the route characteristics were examined and a score was assigned for each factor to the track segment. All scores within a risk component were multiplied to obtain a total score. Based on the total score, a level of probability or consequences was assigned to the track segment. The levels of the three probability components were combined into an overall probability level. Finally, the level of overall probability and the level of consequences were multiplied to obtain the risk of an adjacent track accident for the track segment. Table 2.4 shows an example of the factors affecting one of the probability components—the intrusion rate, the factor scores for each factor based on segment characteristics, and the level of intrusion rate based on total intrusion factor score.

**Table 2.4 Summary of intrusion factor score and level of intrusion rate (Lin & Saat, 2014)**

Intrusion Factor	Criteria	Intrusion Factor Score (IFS)
Distance Between Track Centers, X, in feet (meters)	$X > 80$ (24.4)	1.0
	$55 (16.7) < X \leq 80$ (24.4)	1.5
	$30 (9.1) < X \leq 55$ (16.7)	2.0
	$15 (4.5) < X \leq 30$ (9.1)	3.0
	$X \leq 15$ (4.5)	5.0
Track Alignment	Tangent and level	1.0
	Tangent and on gradient	1.1
	Curved and level	1.5
	Curved and on gradient	1.7
Elevation Differential	Adjacent track is 10 ft. higher	0.7
	Adjacent track is level	1.0
	Adjacent track is 10 ft. lower	1.3
Adjacent Structure	No adjacent structure	1.0
	Single structure	1.1
	Discrete structure	1.2
	Continuous structure	1.3
Containment	All containments installed	0.5
	Physical barrier and guard rail or parapet installed	0.6
	Physical barrier installed only	0.7
	Parapet and guard rail installed	0.8
	Parapet or guard rail installed only	0.9
	No containment installed	1.0
Train Speed	Low (less than 40 mph)	1.0
	Medium (40 mph to 70 mph)	1.2
	High (more than 70 mph)	1.4
<b>The highest score possible</b>		<b>20.11</b>
<b>The lowest score possible</b>		<b>0.35</b>
<b>Total Intrusion Factor Score (IFS)</b>		<b>Level of Intrusion</b>
<b><math>IFS \leq 2</math></b>		<b>1</b>
<b><math>2 &lt; IFS \leq 3</math></b>		<b>2</b>
<b><math>3 &lt; IFS \leq 5</math></b>		<b>3</b>
<b><math>5 &lt; IFS \leq 10</math></b>		<b>4</b>
<b><math>IFS &gt; 10</math></b>		<b>5</b>

The adjacent track accident risks calculated for each segment along a railroad corridor of interest can be compared with each other to identify track segments that have higher risk (the “risk hotspots”) to properly allocate resources to mitigate the risk to an acceptable level.

### **2.3 Shifted Load on an Adjacent Track**

An unbalanced or improperly secured load or lading on freight cars may result in the derailment of freight cars, and may also lead to the intrusion of the load or lading from the freight cars onto adjacent tracks. A train derailment may occur when the shifted load or lading on freight cars is affected by the dynamic train forces or vibrations (for example, track hunting) when a train is running (Loumiet & Jungbauer, 2005). Railroads may already have procedures and guidelines to address cargo securement in order to prevent shifted load or lading. Since there is little research related to the cargo securement specifically for rail transportation, most of the information found was related to cargo securement for road transportation or intermodal transportation. However, these guidelines can be used as references to develop a guideline specifically for cargo securement by rail.

The performance criteria of “how well the cargo is secured” was measured by the ability to withstand the forces being applied to the cargo. The performance criteria developed by the Federal Motor Carrier Safety Administration (Federal Motor Carrier Safety Administration, 2002) required that cargo securement systems should be capable of withstanding the following three forces applied separately:

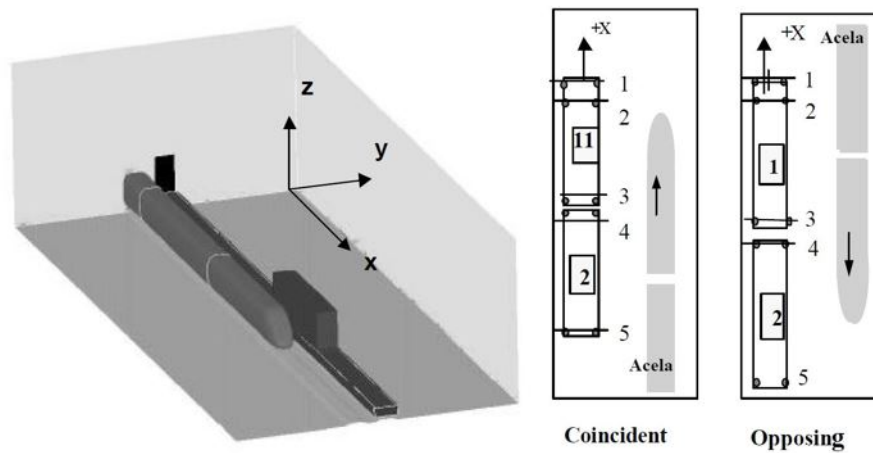
1. 0.8 g deceleration in the forward direction
2. 0.5 g acceleration in the rearward direction
3. 0.5 g acceleration in the lateral direction

Although the original document focused mainly on cargo shipment by road transportation, some of the criteria were adopted by railroads (Union Pacific, 2011). The European Committee for Standardization (CEN) also developed similar performance criteria for cargo securement for cargo shipped by different modes of transportation (European Committee for Standardization, 2010). The European Commission developed detail guidelines for cargo shipment by road transportation (European Commission, 2009).

### **2.4 Aerodynamic Interaction between Trains on Adjacent Tracks**

Train aerodynamics may influence the stability of two trains passing each other. The flow field between trains is complicated and hard to predict because it changes as the relative positions of the trains change. When two trains pass each other, the suction force induced by the aerodynamics may drag the trains toward each other. As the train speed increases, the aerodynamic forces will become stronger and may cause structural fatigue on the trains. If two trains are too close to each other, there is a potential risk for the sides of the two trains to collide due to the suction force, or the lighter rail equipment may be lifted and derail by the suction forces produced by the passage of HSTs. The two main streams of this area of research are wind tunnel tests and computer simulations. Relevant studies from these two streams were reviewed. Most of the research focused on the aerodynamic interaction between two HSTs on adjacent tracks, while few focused on the interaction between conventional trains and HSTs.

Holmes et al. (2000) used a series of computational fluid dynamic (CFD) calculations, combined with train motion simulation software, to characterize the aerodynamic loads of two trains passing each other. The objective was to analyze the aerodynamic effect of an Amtrak Acela train on other slower trains (e.g., a freight train) and investigate the derailment risk caused by the corresponding wind loads. The study chose the Acela train model and double-stack container train model with a 5-car articulated consist for the analysis, as the authors believed the selected train consists provide a larger surface area so that small changes in lateral pressure lead to large lateral effects. Figure 2.5 shows the mesh surface for the Acela train, the container train, and the axis. The authors tested 15 different configurations (cases) of train speeds and directions, wind speeds and directions, and numbers of containers in the freight train consist, as shown in Table 2.5. The aerodynamic forces, moments, yaw and roll motions, and lateral and vertical wheel loads were investigated by comparing the simulation results from selected cases.



**Figure 2.5 Mesh surfaces and schematic of trains with axle numbering system (Holmes et al., 2000)**

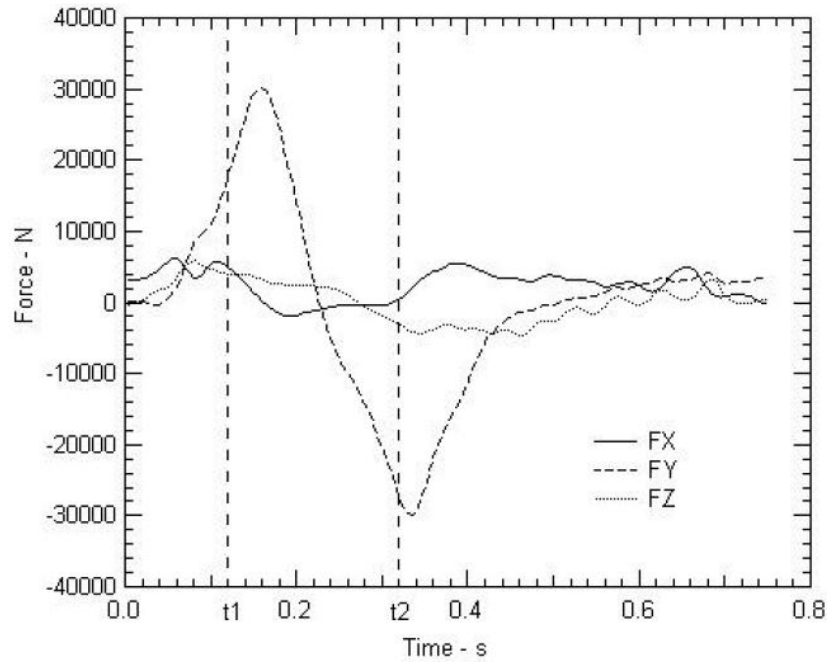


**Table 2.5 Simulation case analysis matrix (Holmes et al., 2000)**

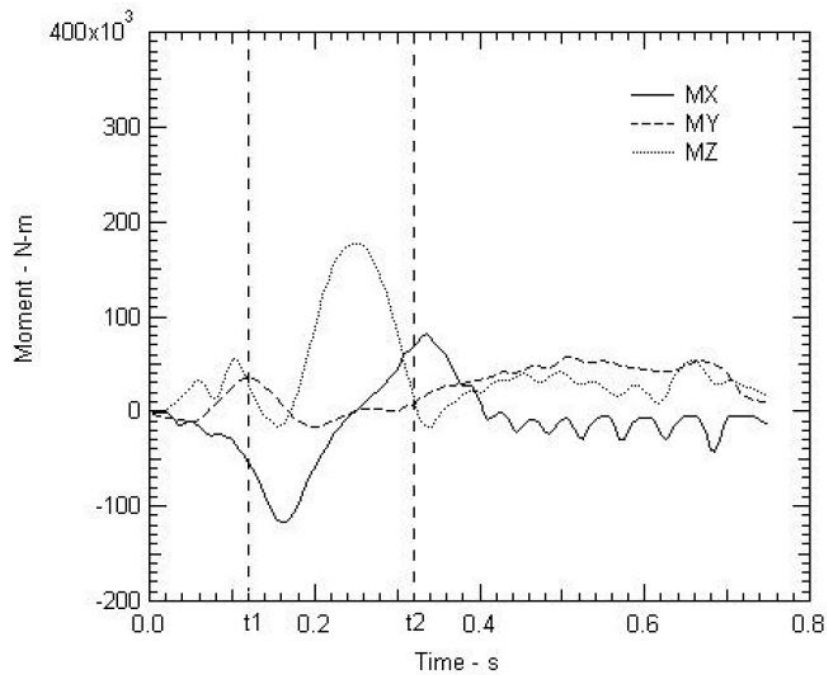
Case	Config.*	Train Velocity		Wind	
		Acela	Freight	X	Y
		(mph)	(mph)	(mph)	(mph)
1	F-S-1	150	-50	0	0
2	F-S-3	150	-50	0	0
3	R-S-1	150	-50	0	0
4	F-C-1	150	-50	0	0
5	F-S-3	150	-50	-50	0
6	F-S-1	150	-50	50	0
7	F-S-1	150	50	50	0
8	F-S-1	150	50	-50	0
9	F-S-1	150	-50	0	-50
10	F-S-1	150	30	50	0
11	F-S-1	150	15	50	0
12	F-S-1	150	30	-50	0
13	F-S-1	150	15	-50	0
14	R-S-1	150	50	-50	-50
15	F-S-1	120	50	-50	0

\*Gives interaction location (F = front, R = rear) container end geometry (S = simple, C = staggered) and number of containers in row.

Figure 2.6 shows the time histories of the three-dimensional aerodynamic forces and moments acting on the freight train as two trains passed each other with Case 1 configuration. Two peaks of lateral forces (along Y axis) were exerted on the freight train as the Acela locomotive passed the front end of the container freight car. Strong rolling (MX) and yaw moment (moment MZ) was exerted to the container, but little pitching moment (MY) was found. The Acela locomotive produced more aerodynamic loads in a headwind, and produced less aerodynamic loads with a tailwind.



(a)

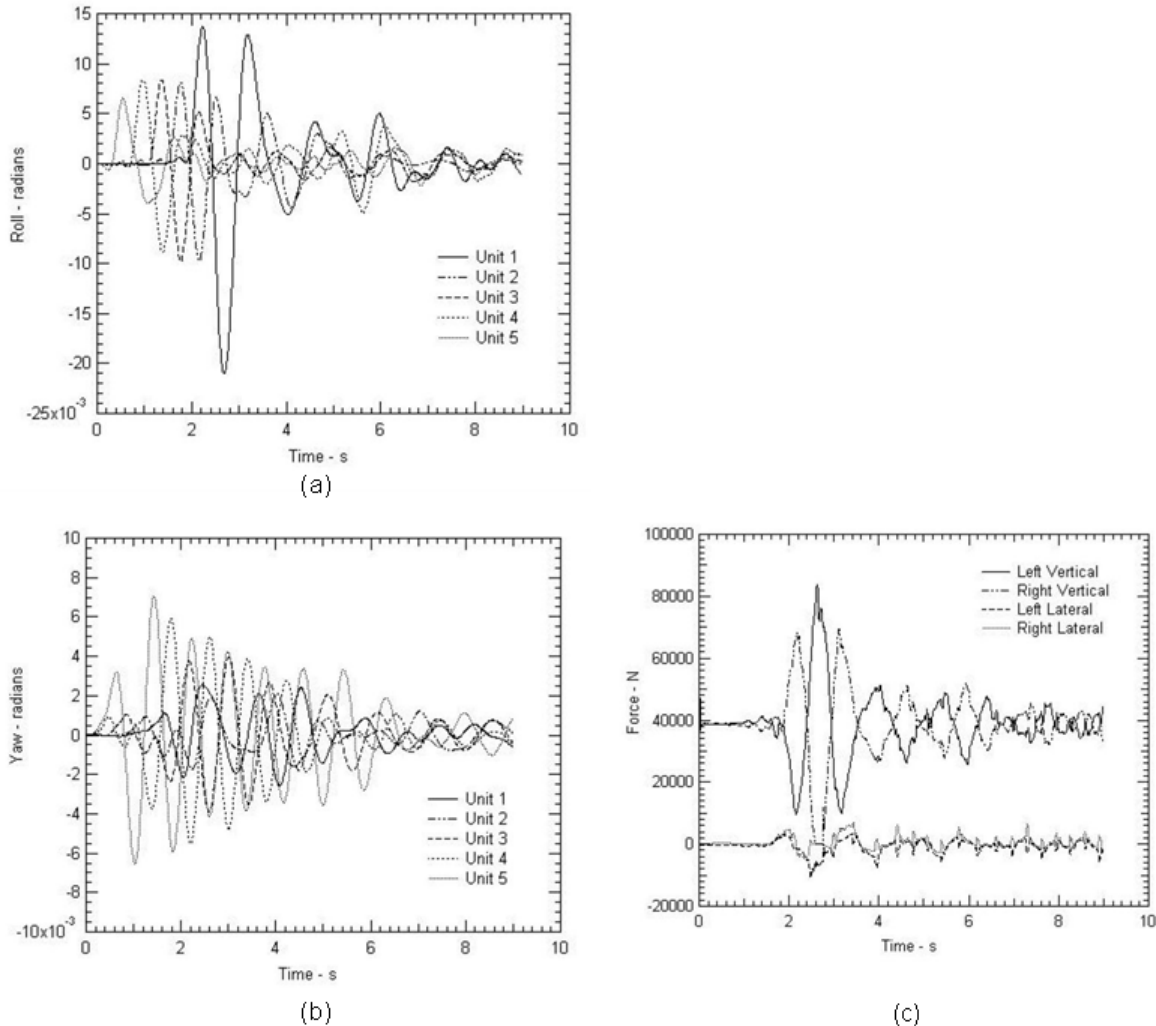


(b)

**Figure 2.6 Time histories of the (a) Aerodynamic forces and (b) Aerodynamic moments acting on the container car for Case 1 (Holmes et al., 2000)**

Figure 2.7 shows the aerodynamic response of the freight container in Case 8, believed by the authors to offer the worst-case scenario for derailment risk. This case featured the two trains

traveling in the same direction, facing a headwind. The result showed that the largest rolling motion was found at the first car and the largest yaw moment was found in the last (fifth) car. Container cars at the ends of the consist had the largest lateral displacement. This suggested that the derailment was more likely to occur at the end cars. The result also showed that even with the worst-case scenario, derailment was unlikely to occur. However, this test specified the maximum wind speed to be 50 mph, and the maximum speed for freight train and the Acela were 50 mph and 150 mph, respectively. Increased train speed would presumably entail higher derailment risk. The study also did not consider the effects of the space between trains. Closer spacing between trains could result in greater aerodynamic forces and thus higher derailment risk.



**Figure 2.7 Time histories of the (a) Roll motions (b) Yaw motions, and (c) Wheel loads on the container car for Case 8 (Holmes et al., 2000)**

Fujii and Ogawa (1995) used a domain decomposition method and a fortified solution algorithm to simulate the flow fields of two identical high-speed trains moving at the same speed in opposite directions passing each other inside a tunnel. The research also investigated the time sequence of the flow field and the time history of the aerodynamic forces acting on the trains as two trains pass each other. The shape of the high-speed train was assumed to be a bullet train

with noses and shoulders, as shown in Figure 2.8. Figure 2.9 shows the time history of the pressure coefficient on the side-wall surface facing the opposite train. And Figure 2.10 shows the time history of various aerodynamic loads on the train normalized by the projected cross-section area of the train. The simulation result showed that the peak of pressure reached its high peak when the nose of a train passed the longitudinal center of the other train and its low peak when the shoulder of the train passed the longitudinal center. The suction force imposed on the side of the trains pulled the trains toward each other. The takeaway of the analysis was that the mechanism of the aerodynamic forces was mainly governed by the movement of the high stagnation pressure at the nose of the train and the strong low pressure region near the shoulder of the train (Fujii & Ogawa, 1995). The research suggested that the design of the frontal part of the train may greatly influence the aerodynamic interaction between trains on adjacent tracks.

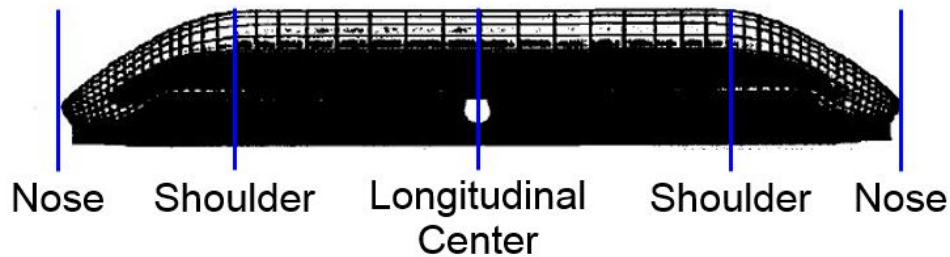


Figure 2.8 Schematic picture and the computational grid of the train (Fujii & Ogawa, 1995)

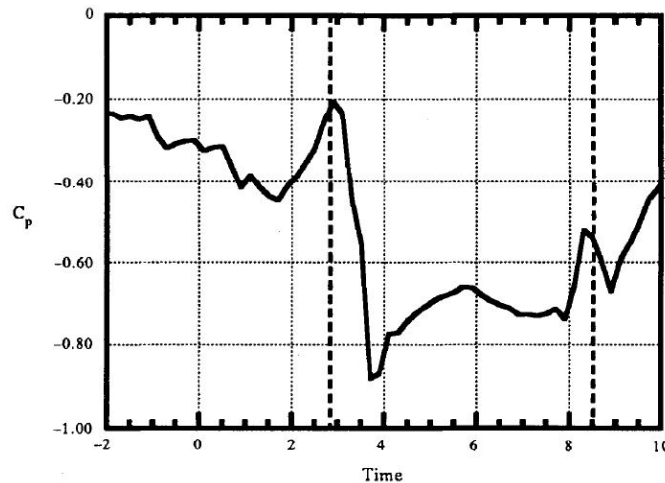
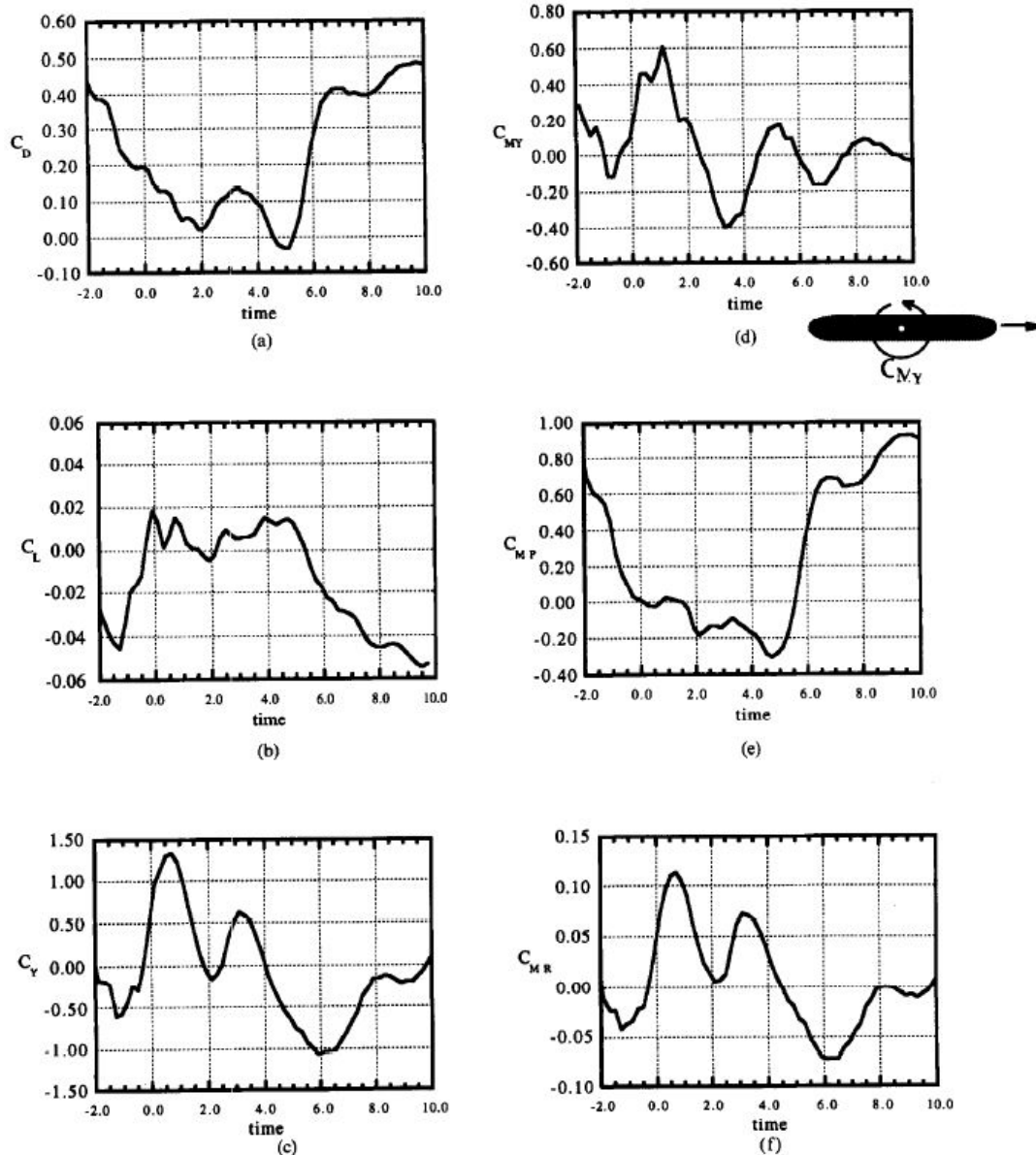


Figure 2.9 Time history of the pressure coefficient on the side-wall surface facing to the opposite train; the broken lines indicate the time when the front and rear noses of the opposite train pass the longitudinal center (Fujii & Ogawa, 1995)



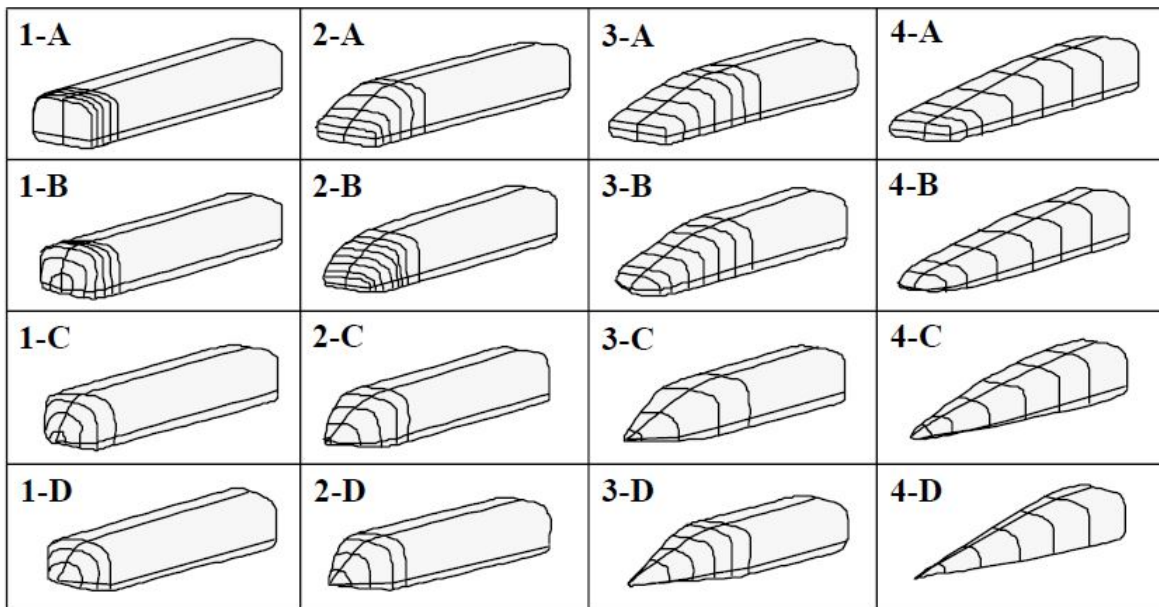
**Figure 2.10 Time history of the aerodynamic loads on the train (a) Drag coefficient (b) Side force coefficient (c) Lift coefficient (d) Yawing moment coefficient (e) Pitching moment coefficient (f) Rolling moment (Fujii & Ogawa, 1995)**

Other numerical simulation methods have been adopted to address the topic by using empirical formulae (Wang, 2000), unsteady compressive non-homentropic flow theory (Mei, 1999; 2002), boundary element method (Hermanns, 2005), and dynamic mesh technique (Tian, 2001) (Bi, 2006) (Liu, 2009) (Hwang, 1999) (Fujii & Ogawa, 1995).

Raghunathan et al. (2002) conducted a wind tunnel experiment to investigate the flow fields and aerodynamic forces induced by trains of different head and tail shapes (Figure 2.11). Two wind tunnel tests were performed to investigate the effect of aerodynamic forces of two trains passing each other. The first measured the variation of pressure on the side of the train when it passed.

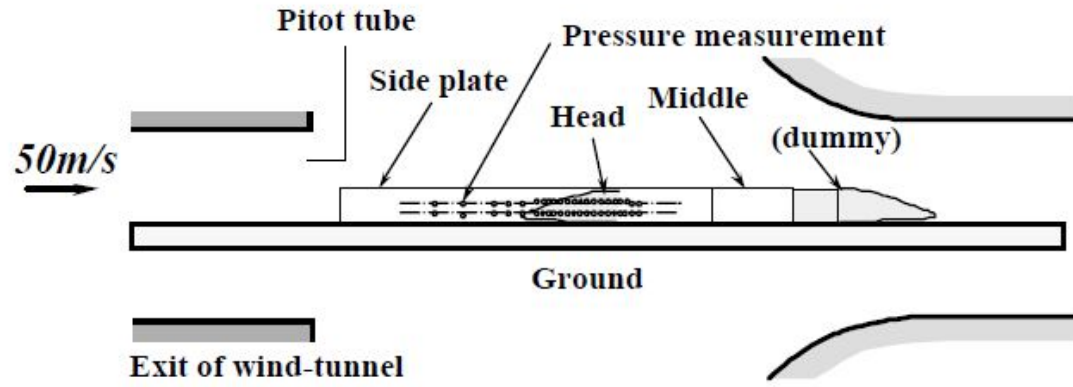
Figure 2.12 illustrates an experimental rig where a train passed a fixed plate with pressure

measurement devices, and [Figure 2.13](#) shows the peak pressure produced by various types of train shape when the front and rear part of the train passed the fixed plate. The result showed that peak pressure occurred when the front or rear part of the train passed the fixed plate, and the peak pressure due to the passage of the front part of the train was larger than that of the rear part of the train. The results of this study were consistent with the results from Fujii and Owaga (1995). In addition, both the type of the shape design and the length of the front and rear part of the train were identified to affect peak pressure.

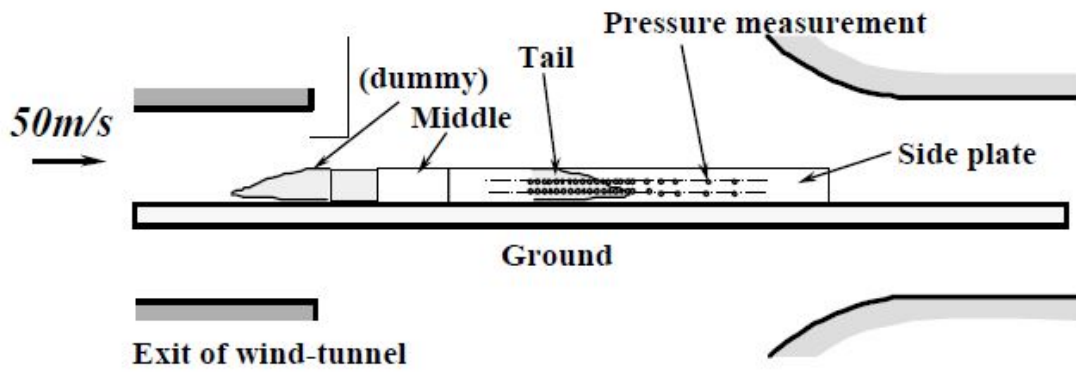


**Figure 2.11 Model train configuration (Raghunathan et al., 2002)**

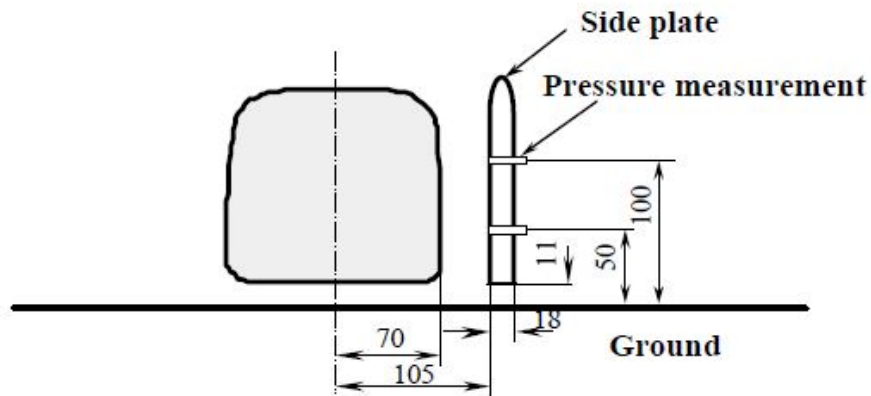




(a) Measurement of train head

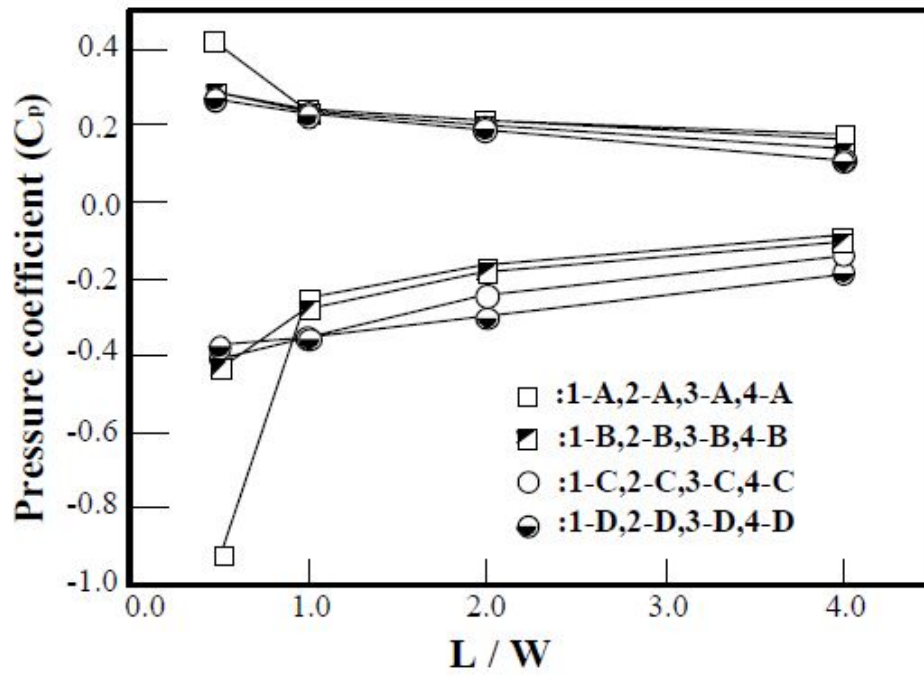


(b) Measurement of train tail

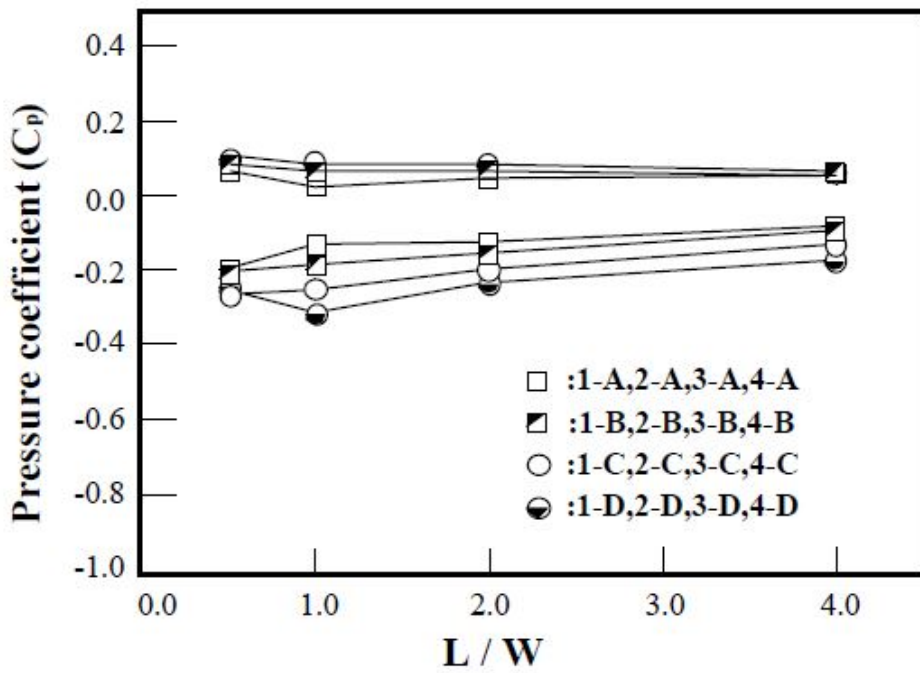


(c) Model train and side plate

Figure 2.12 The rig for pressure variation measurement (Raghunathan et al., 2002)



(a)

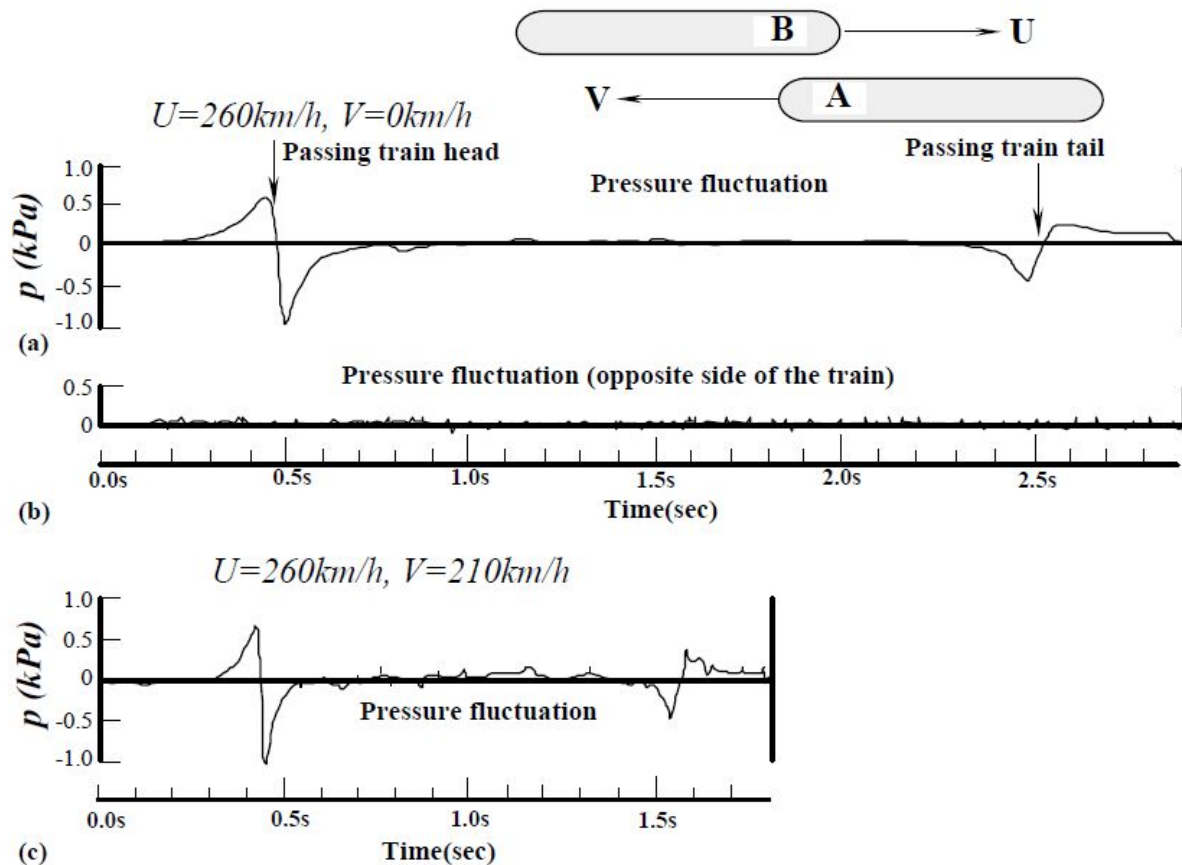


(b)

Figure 2.13 Effect of train head on (left) and tail on (right) pressure variation (Raghunathan et al., 2002)



The second test Raghunathan et al. (2002) conducted was a time history of pressure variation when two trains pass each other in two cases (Figure 2.14). In the first case, the speed of the first train was 260 km/h (c.a. 160 mph) and the speed of the other train was 0. In the second case, the speed of the first train was 260 km/h and the speed of the other train was 210 km/h (c.a. 130 mph). The result showed again that peak pressure due to the passage of the front part of the train was larger than that of the rear part of the train. It is noteworthy that in the open air, the pressures, produced on the opposite side of the trains passing each other, remained almost constant at atmospheric pressure without significant fluctuation.



**Figure 2.14 Pressure variations occurring when two trains pass each other (Raghunathan et al., 2002)**

Li et al. (2011) performed wind tunnel experiments and a wind bridge vehicle (WVB) system to investigate the aerodynamic behaviors of trains passing each other on a bridge deck under crosswind, considering the effects of lateral distance between two trains, wind speed, and train speed. Figure 2.15 illustrates two cases of adjacent track arrangement on a bridge. Figure 2.16 shows the response of lateral acceleration of the first car of one train. Similar to previous research, there were two peaks at the beginning and end of two trains passing each other mid-span on the bridge. Two trains passing each other in opposite directions at various vehicle speeds were analyzed (Table 2.6). The main finding was that the higher the train speed, the stronger the effects of the sudden change of the wind load. Table 2.7 shows the response of acceleration for trains in various wind speeds and with different train (track) spacings. The result suggested that

the sudden change of wind loads (and thus the lateral acceleration of the train) was smaller when two trains were further apart.

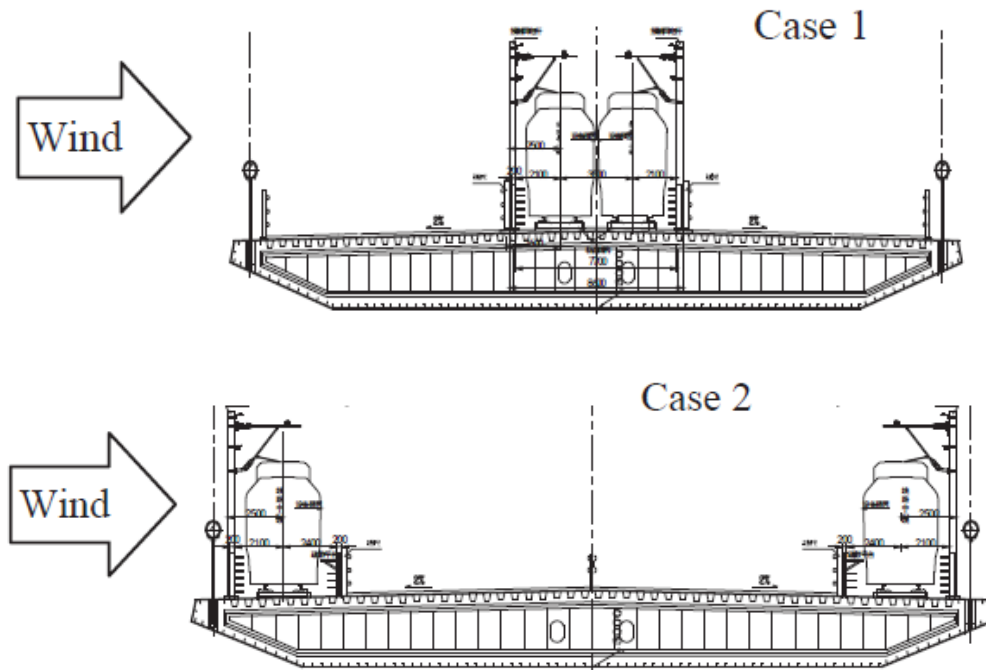


Figure 2.15 Schematic diagram of two trains pass each other under crosswind condition with two kinds of track separation (Li et al., 2011)

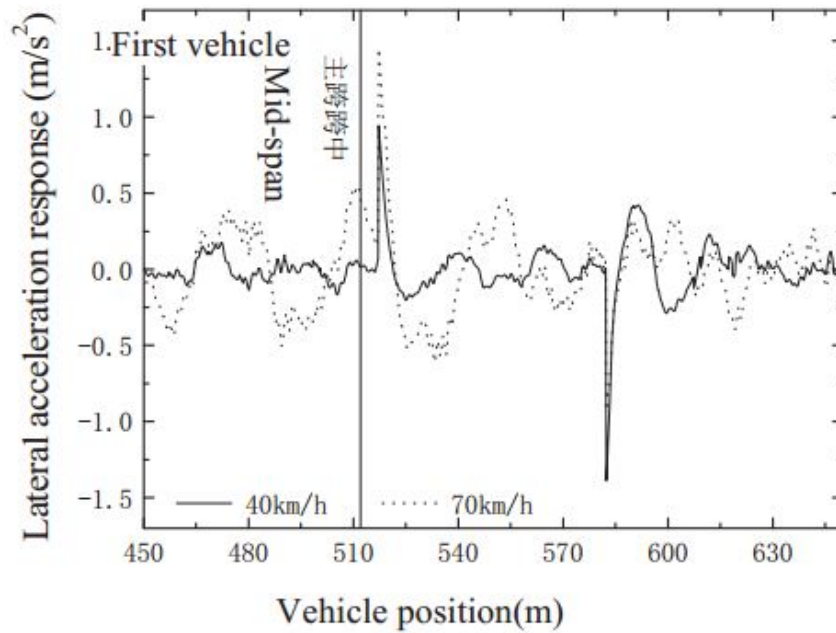


Figure 2.16 Response of lateral acceleration of the train (Li et al., 2011)

**Table 2.6 Response of acceleration of train at various train speeds (Li et al., 2011)**

Vehicle speed/(km/h)		40	50	60	70	80
Leeward vehicle	Lateral acceleration(m/s <sup>2</sup> )	1.566	1.488	1.258	1.840	1.793
	Vertical acceleration(m/s <sup>2</sup> )	1.841	1.869	1.693	1.861	1.710
Windward vehicle	Lateral acceleration(m/s <sup>2</sup> )	0.472	0.534	0.680	0.854	0.995
	Vertical acceleration(m/s <sup>2</sup> )	1.809	1.850	1.692	1.831	1.812

**Table 2.7 Acceleration of train under different crosswind speed when the space between two trains are (a) 3.5 meters apart and (b) 29.5 meters apart. (Li et al., 2011)**

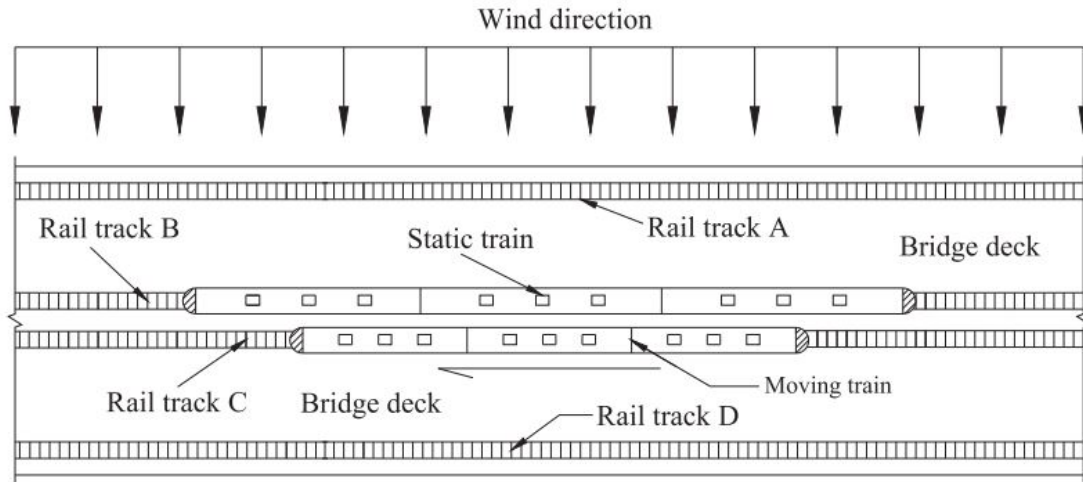
Wind speed(m/s)		10	15	20	25	30
Leeward vehicle	Lateral acceleration(m/s <sup>2</sup> )	0.837	0.836	0.810	1.017	1.793
	Vertical acceleration(m/s <sup>2</sup> )	0.743	1.022	0.999	1.561	1.710
Windward vehicle	Lateral acceleration(m/s <sup>2</sup> )	0.806	0.806	0.850	0.886	0.995
	Vertical acceleration(m/s <sup>2</sup> )	0.948	1.036	0.916	1.412	1.812
Maximum lateral acceleration in midspan(m/s <sup>2</sup> )		0.054	0.064	0.063	0.065	0.142
Maximum vertical acceleration in midspan(m/s <sup>2</sup> )		0.133	0.215	0.441	0.773	1.180

(a)

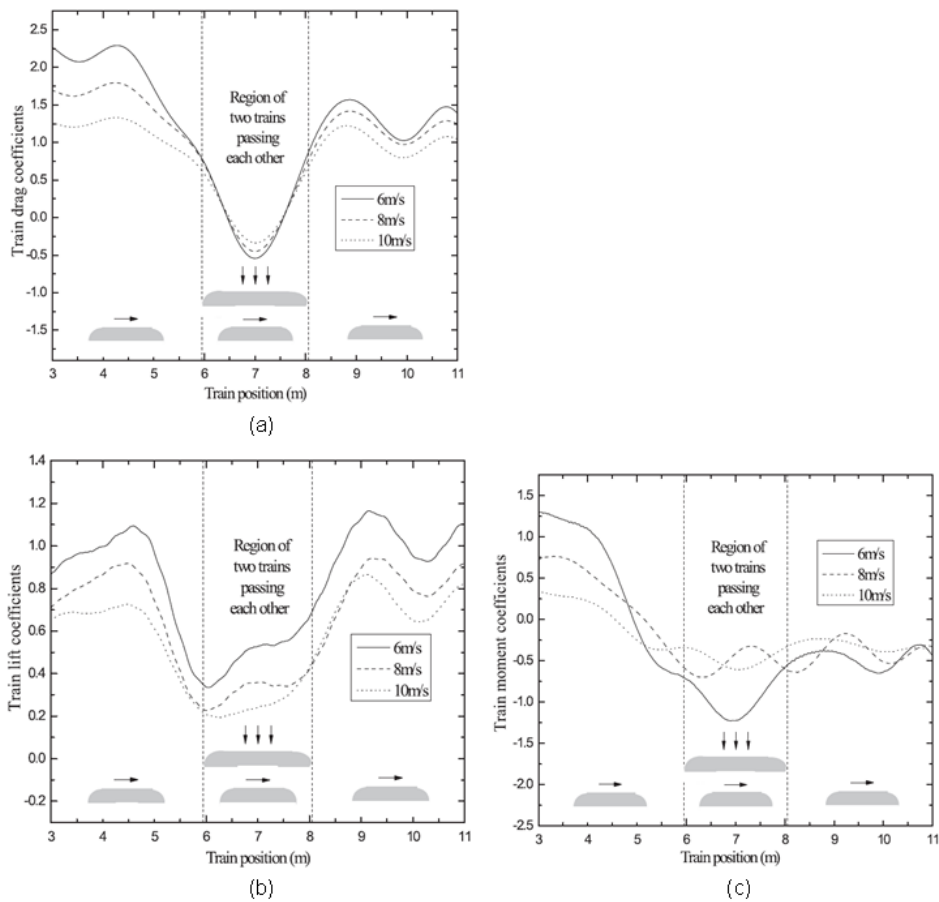
Wind speed(m/s)		10	15	20	25	30
Leeward vehicle	Lateral acceleration(m/s <sup>2</sup> )	0.838	0.837	0.811	0.873	1.201
	Vertical acceleration(m/s <sup>2</sup> )	0.764	0.975	0.914	1.437	1.645
Windward vehicle	Lateral acceleration(m/s <sup>2</sup> )	0.807	0.821	0.841	0.867	0.949
	Vertical acceleration(m/s <sup>2</sup> )	0.897	1.002	0.984	1.591	1.779

(b)

Li et al. (2013) extended the previous study by focusing on the sudden change of wind loads acting on trains when they are passing each other under the effect of crosswind, which may impact the stability of trains and the comfort of passengers (Li et al., 2011, 2013). [Figure 2.17](#) illustrates the schematic diagram of one train passing a static train. The result showed that the sudden change of wind loads of the train on the downwind side was larger than that on the windward side. The time histories of the three component coefficients (drag, moment, and lift) were developed with different crosswind speeds ([Figure 2.18](#)). The result also showed that the higher the crosswind speed, the weaker the magnitude of the sudden change of the trains' drag and lift coefficients, while the change of moment coefficient was not affected by the wind speed. Please note that in this research, only the middle car of the three-car consist was measured in order to avoid the influence of the geometry of train design in the ends of the train. The effect of the crosswind combined with train geometry design on the aerodynamic behavior of trains may require further study.



**Figure 2.17 Schematic diagram of testing train on leeward (downwind) rail track (track C) of the crosswind when two trains pass each other (Li et al., 2013)**



**Figure 2.18 Time histories of train's (a) drag coefficients (b) lift coefficient and (c) moment coefficients when the testing train is on the leeward track (Li et al., 2013)**

The aerodynamic effect may also impact other operations on adjacent tracks. For example, the aerodynamic force produced by HSTs may suck or push MOW personnel working on the adjacent track if the track spacing between two tracks is short and no barrier exists that can block or absorb the forces. Research specifically addressing this issue is not currently available. Thus, further risk assessment and evaluation is needed.

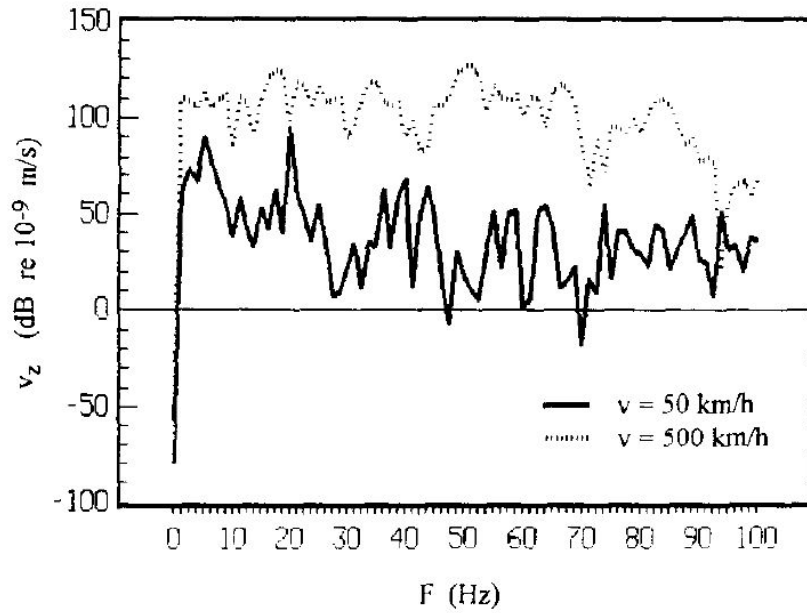
## 2.5 Ground-Borne Vibration and Its Effect on HSR Track Geometry

Ground-borne vibration is the vibration energy created by train wheels rolling on rails. The vibration waves propagate through the various soil and rock to the foundations of adjacent tracks. In extreme cases, vibration energy may cause subgrade problems and thus track geometry problems.

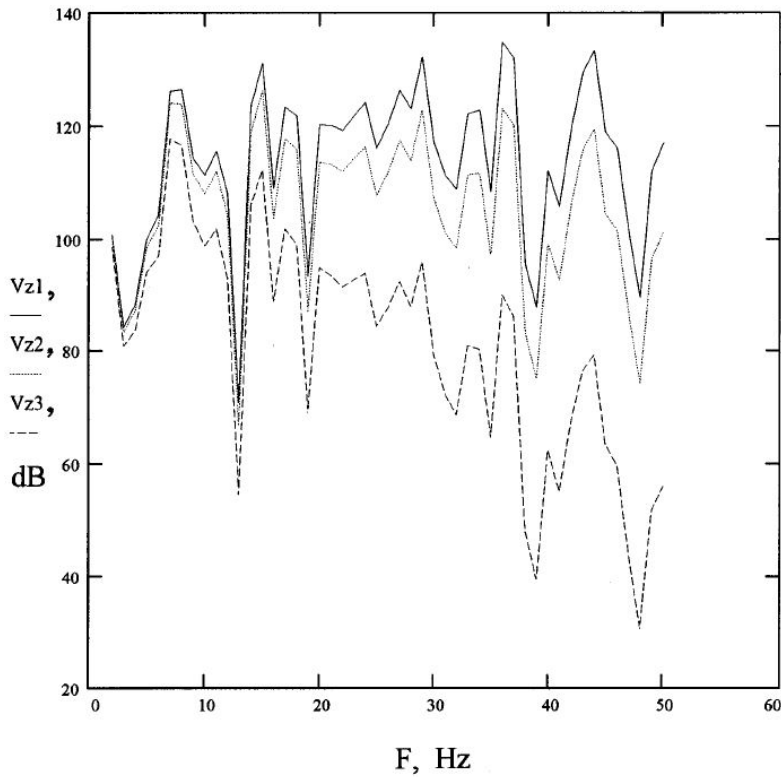
Ground-borne vibration induced by different types of passing trains has been widely studied, involving conventional passenger trains and freight trains (Dawn, 1983) (Krylov & Ferguson, 1993) (Jones & Block, 1996), urban transit systems (Saurenman & Nelson, 1983) (Hanson et al., 2006), and HST (Krylov, 1995) (Madshus & Kaynia, 2000) (Takemiya, 2003) (Hanson et al., 2012). As the train speed increased, stronger ground-borne vibration was observed (Krylov, 1993). One specific issue of ground-borne vibration with HSR operation is that the ground vibration level may significantly increase if the train speed exceeds the velocity of Rayleigh surface waves (Krylov, 1995). This train speed is usually called “critical speed.” Even when the train speed was close to (but not exceeding) the critical speed, a high ground vibration level was also observed. Intense ground vibration is not only affected by train speed but also by soil, track, and substructure properties. Krylov (1995, 1996, 1998, 2000) conducted a series of research to analyze the effect of a “trans-Rayleigh train” (when the train speed exceeds the velocity of Rayleigh waves) on ground vibration and the effects of the aforementioned factors. [Figure 2.19](#) shows the vibration level in decibels, with regard to the reference level of  $10^{-9}$  m/s (39 in./s)<sup>1</sup> produced by a train at sub-Rayleigh speed and trans-Rayleigh speed. The result showed that the average ground vibration level for trains at trans-Rayleigh speed was much higher than those at sub-Rayleigh speed. [Figure 2.20](#) shows the effect of soil attenuation on ground vibration level. Different soil types resulted in different soil attenuation coefficients and thus different Rayleigh speeds.

---

<sup>1</sup> The decibel (dB) is a logarithmic unit to express the ratio of two physical quantities. The dB number in this paragraph represents “how many times the vibration velocity is higher than the reference velocity of  $10^{-9}$  m/s. For instance, a 70 dB vibration level means the vibration velocity is approximately  $\sqrt{10^{\frac{70}{10}}}$ , or 3,162 times higher than the reference velocity of  $10^{-9}$  m/s.



**Figure 2.19** Ground vibration spectra (dB reference  $10^{-9}$  m/s) generated by a train of five cars moving at sub-Rayleigh and trans-Rayleigh speeds. (Krylov, 1995)



**Figure 2.20** Effect of soil attenuation constant  $\gamma$  on ground vibration level (dB reference  $10^{-9}$  m/s) generated by a train of five cars moving at three trans-Rayleigh speeds: 50 km/h (Vz1), 150 km/h (Vz2), and 250 km/h (Vz3). (Krylov, 1996)

Hanson et al. (2006) developed procedures for the assessment of potential noise and vibration impacts resulting from HSGGT projects and updated the suggestions and procedures in 2012 (Hanson et al., 2012). The report provided the procedures for predicting and assessing noise and vibration as well as criteria for assessing the potential magnitude of potential impacts.

Numerous studies have been carried out regarding ground-borne vibration of passing trains. However, no specific study was found on the effect of ground-borne vibration of passing trains on the operation of HSTs adjacent to conventional tracks. In addition, there has been considerable research addressing the effect of irregular track geometry or foundation on the ground-borne vibration of HST (Jones & Block, 1996) (Krylov, 1996) (Sheng, 2004a, 2004b) (Nielsen et al., 2013). For example, Krylov (1996) suggested that by using appropriate artificial reduction of minimal track wave velocity (e.g., using softer ballast layer or rubber pad underneath the track), ground-borne vibration for HSR may be reduced. Sheng (2004a, 2004b) found that increasing track bending stiffness or decreasing track mass may reduce the ground vibration level. However, no specific study was found addressing the effect of the ground-borne vibration of trains from conventional tracks on HSR track geometry. Hence, more research in this area may also be required. Ground-borne vibration by itself may not significantly affect the safety of operating a HST adjacent to conventional railroads, but it can be a contributing hazard factor when combined with the aerodynamic effect of two trains passing each other. As such, more research on the combined effect of train aerodynamics and train-induced ground vibration may be required.

## **2.6 Intrusion of Maintenance-of-Way Staff and Equipment Working on the Adjacent Track**

The intrusion of maintenance of way (MOW) staff or vehicles on adjacent track may result in a collision between the MOW staff or vehicles and a conventional or high-speed train. This may cause roadway worker casualties, equipment damage, system disturbance (train delay), train derailments, and passenger casualties (if a passenger train strikes a MOW vehicle or derails due to emergency brake). People in a train are protected by the rolling stock, which can absorb some crash energy. If the passenger train has a locomotive, in some cases it can protect passenger cars from the direct impact of a collision. MOW staff and equipment, however, are unprotected in such collisions, as MOW staff may be directly struck by the train. MOW equipment usually cannot protect personnel inside the vehicle, nor can it serve as a buffer to absorb the crash energy. From 1997 to 2010, there were nine roadway worker fatalities on adjacent tracks due to no or improper on-track safety procedures, miscommunication between the maintenance workers and the dispatcher, or the lack of awareness of the maintenance workers (Federal Railroad Administration, 2011a).

The safety and protection of MOW staff and equipment, including protection from adjacent tracks, is addressed in the Roadway Worker Protection (RWP) Rule. The RWP was published in 1996 (effective January 15, 1997) by the Rail Safety Advisory Committee (RSAC), established in 1996 by FRA. The RWP regulated that railroads should “adopt and implement a program that affords on-track safety to all roadway workers.” On-track safety was achieved by providing a “working limit” and a “train approach warning.”



Working limit was defined as “*a segment of track with definite boundaries which trains and engines may move only as authorized by the roadway worker having control over that defined segment of track (the roadway worker in charge)*” (Federal Railroad Administration, 2011). A train approach warning was another common method of performing on-track safety where “*a trained and qualified watchman/lookout provides warning to roadway worker(s) of the approach of a train or on-track equipment in sufficient time to enable each roadway worker to move to and occupy a previously arranged place of safety...*” (Federal Railroad Administration, 2011a) The specific part in the 1996 RWP regulation stated that “*roadway work groups engaged in large-scale maintenance or construction be provided with on-track safety in the form of ‘train approach warning’ for train or equipment on adjacent tracks if the adjacent tracks are not already within the working limits*” (Federal Railroad Administration, 2011a). Note that the “adjacent track” here was defined as “any track centers 25 feet apart from the track center to which a roadway work group was assigned to perform large-scale maintenance or construction.” (Federal Railroad Administration, 2011a)

The RWP rule has been amended several times. FRA (2004) issued Notice of Safety Advisory 2004-01 to review existing rules and recommend certain safety practices for the protection of MOW staff and equipment from trains on the adjacent track due to five roadway worker fatalities in 2003, suggesting that improvement of roadway worker protection was needed. In 2009, FRA published a Notice of Proposed Rulemaking to amend the regulation again to further reduce the risk of roadway workers performing work near adjacent tracks, effective May 1, 2012 (Federal Railroad Administration, 2011a). FRA issued another amendment of RWP rule in 2014 to clarify certain ambiguity in terms and respond to the comments and suggestions from the industry. One of the major changes was increasing the maximum authorized speed at which a passenger train may move on an adjacent track from 25 mph to 40 mph while roadway workers continue their work (FRA, 2014).

Table 2.8 shows a summary of on-track safety procedures for certain roadway work groups and adjacent tracks based on current RWP rules. Figure 2.21 shows six graphical examples of applying RWP rules.

RWP rules developed by FRA apply to railroad systems under FRA’s regulations (generally, conventional tracks). Therefore, some of the RWP may not be suitable for the operation of HSR systems or the shared-use of HSR tracks and conventional tracks. For example, the purpose of a train approaching warning is to provide time for MOW staff to move to a safe place away from trains passing through the adjacent track by notifying a watchman/lookout. However, the high speed of HSTs increases the risk of not being able to move in time before the train comes, and slowing down a HST to 40 mph may not be practical, as this may significantly impact the capacity and operation of the HSR line. RWP also suggests the installation of an inter-track barrier as a method to protect MOW staff and equipment from trains on adjacent tracks without disturbing maintenance work; minimum criteria set by FRA may not suffice when the adjacent track is an HSR track because of the faster speed and the suction forces produced by the aerodynamic effect discussed in Section 2.4. In addition, the definition of an adjacent track in the RWP only includes tracks 25 feet or less apart (track-center-to-track-center); this should be reconsidered and re-evaluated as sharing tracks or ROW between HSR and conventional train systems are being considered.



**Table 2.8 Summary of current on-track safety procedures for certain roadway work groups and adjacent tracks (FRA, 2014)**

Example No./ Diagram No. (see Figure 1)	"Side A" of the Occupied Track—the side from the vertical plane of the near running rail of the occupied track extending outward through to the fouling space of the adjacent controlled track ("No. 1" Track)		On or Between the Rails of the Occupied Track ("No. 2" Track), where On-Track Safety Is Established through Working Limits	"Side B" of the Occupied Track—either (1) the side with no adjacent track or (2) the side from the vertical plane of the near running rail of the occupied track extending outward through to the fouling space of the adjacent controlled track ("No. 3" Track)	
	Method of On-Track Safety on Side A	Requirements	Requirements	Requirements	Method of On-Track Safety on Side B
1	Working limits or train approach warning	Upon receiving a notification or warning for movement(s) ("movement notification or warning") for No. 1, cease work and occupy a predetermined place of safety ("PPOS"). <sup>1</sup>	Upon movement notification or warning for No. 1, cease work and occupy a PPOS, except work may continue during movement(s) on No. 1 auth'd. at 25 mph or less if maintain 25' spacing. <sup>2</sup>	Work <sup>3</sup> is not required to cease during movement(s) on No. 1.	Not applicable (N/A), because there is no adjacent track
2	Working limits	Upon movement notification for No. 1, cease work and occupy a PPOS. Work <sup>3</sup> is not required to cease during movement(s) on No. 3.	Upon movement notification for No. 1 or No. 3, cease work and occupy a PPOS, except work may continue during movement(s) on No. 1 or No. 3 auth'd. at 25 mph or less if maintain 25' spacing. <sup>2</sup>	Upon movement notification for No. 3, cease work and occupy a PPOS. Work <sup>3</sup> is not required to cease during movement(s) on No. 1.	Working limits
3	Working limits	Upon movement notification for No. 1, cease work and occupy a PPOS. Work <sup>3</sup> is not required to cease during movement(s) on No. 3.	Upon movement notification for No. 1 or warning for No. 3, cease work and occupy a PPOS, except work may continue during movement(s) on No. 1 or No. 3 auth'd. at 25 mph or less if maintain 25' spacing. <sup>2</sup>	Upon movement warning for No. 3 or notification for No. 1, cease work and occupy a PPOS.	Train approach warning
4	Train approach warning	Upon movement warning for No. 1 or No. 3, cease work and occupy a PPOS.	Upon movement warning for No. 1 or No. 3, cease work and occupy a PPOS, except work may continue during movement(s) on No. 1 or No. 3 auth'd. at 25 mph or less if maintain 25' spacing. <sup>2</sup>	Upon movement warning for No. 3 or No. 1, cease work and occupy safety PPOS.	Train approach warning
5	None, but with inter-track barrier	Work is prohibited on No. 1 and up to barrier ("Side A1"). Work is not required to cease btwn. barrier and near running rail of occupied track ("Side A2") during movement(s) on No. 1.	Work is not required to cease during movement(s) on No. 1.	Work is not required to cease during movement(s) on No. 1.	N/A, because there is no adjacent track
6	None, but with inter-track barrier	Work is prohibited on Side A1. Work <sup>3</sup> is not required to cease on Side A2 during movement(s) on No. 1 or No. 3.	Work is not required to cease during movement(s) on No. 1. Upon movement notification or warning for No. 3, cease work and occupy a PPOS, except work may continue during movement(s) on No. 3 auth'd. at 25 mph or less if maintain 25' spacing. <sup>2</sup>	Upon movement notification or warning for No. 3, cease work and occupy a PPOS. Work <sup>3</sup> is not required to cease during movement(s) on No. 1.	Working limits or train approach warning

<sup>1</sup> As used in the above table, a "predetermined place of safety" (or "PPOS") means a specific location that an affected roadway worker must occupy upon receiving a watchman/lookout's warning of approaching movement(s) ("warning") or a roadway worker in charge's ("RWIC's") notification of pending movement(s) on an adjacent track ("notification"), as designated during the on-track safety job briefing required by § 214.315. The PPOS may not be on a track, unless the track has working limits on it and no movements permitted within such working limits by the RWIC. Thus, under these circumstances, the space between the rails of the occupied track (No. 2 in this table) may be designated as a place to remain in position or to otherwise occupy upon receiving a warning or notification. The RWIC must determine any change to a PPOS, and communicate such change to all affected roadway workers through an updated on-track safety job briefing.

<sup>2</sup> On-ground work is prohibited in the areas 25' in front of and 25' behind equipment on the occupied track (No. 2), and must not break the plane of a rail on No. 2 towards a side of No. 2 unless work is permitted on that side. Note, however, that per § 214.336(a)(2)(i), work would no longer be permitted to continue on or between the rails of the occupied track during movement(s) on an adjacent controlled track at 25 mph or less if there is a simultaneous movement on the other adjacent controlled track at more than 25 mph.

<sup>3</sup> Work that does not break the plane of the near running rail of the occupied track (No. 2) is not required to cease during such movements; work that breaks the plane of the near running rail of the occupied track may also continue: 1) during the times that work is permitted on or between the rails of the occupied track in accordance with § 214.336(c) (Procedures for adjacent-controlled-track movements 25 mph or less); or 2) if such work is performed alongside a roadway maintenance machine or coupled equipment in accordance with § 214.336(e)(2).

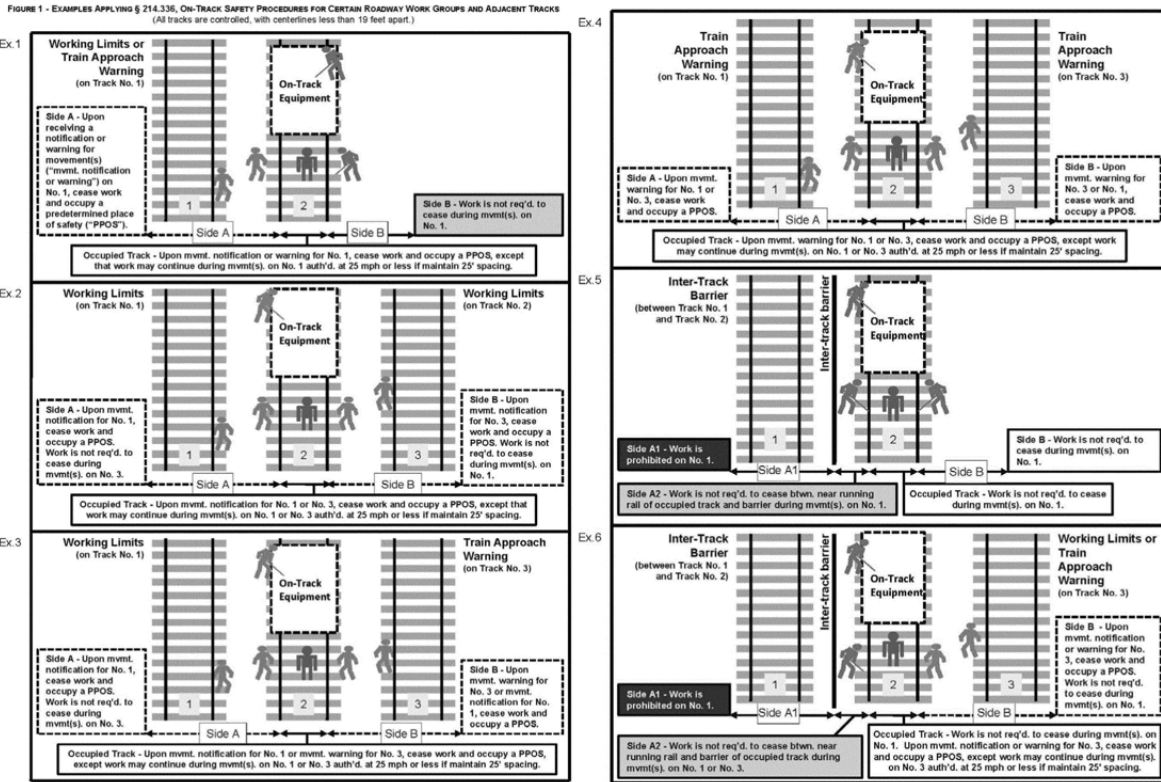


Figure 2.21 Graphical examples of current on-track safety procedures for certain roadway work groups and adjacent tracks (Federal Railroad Administration, 2014)

## 2.7 Obstruction Hazard Resulting from an Adjacent Track (Non-Derailment and Grade-Crossing Collisions)

Obstructions fouling HSR track from adjacent tracks can result from a shifted load of railroad cars (Section 2.3) or from the collision of a train and a road vehicle. This collision can result from the grade crossing on conventional tracks or from non-grade-crossing areas. In one case, a grade-crossing accident caused a train to derail and foul the adjacent track, where it collided with railroad cars on adjacent tracks (National Traffic Safety Board, 2002). In another, a train struck a sports utility vehicle in a non-grade-crossing area, causing the train to derail and strike railroad cars on the adjacent track (Federal Railroad Administration, 2005). Both cases showed that the obstruction hazard stemmed from collisions between a train and a road vehicle. Thus, in this section, a review of current regulations and studies with regard to grade-crossings are presented.

Grade-crossing rules and guidelines for high-speed corridors are regulated both at a national (Federal Railroad Administration, 2009) and State (Jennings, 2009) level. Table 2.9 shows the FRA requirement of grade-crossing protection and closure. The sealed corridor concept was introduced by the North Carolina Department of Transportation and was defined as “an extended rail corridor or segment thereof on which all public at grade crossing are evaluated through an engineering diagnostic process to determine the appropriate level of safety improvement needed to decrease or eliminate violations.” (Federal Railroad Administration, 2009) It is desirable for all grade crossings along HSR lines to be eliminated, while for higher speed operation (110 mph to 125 mph maximum operating speed), grade-crossing separation or closure is recommended

but not required. Hence, there is a risk for HSTs to strike a highway vehicle. In this situation, FRA required grade crossings to have approved grade-crossing protection systems that can prevent highway vehicles from intruding the railroad ROW. In addition, obstruction detection systems, which alert the train if a highway vehicle encroaches on the ROW of the tracks, are also recommended.

In addition to the Federal regulation, most States have its own regulations to provide additional considerations for the elimination and protection of grade-crossings. For example, in Illinois, additional criteria were considered by the Illinois Commerce Commission, which has statutory authority to order the elimination of grade crossings. The criteria include speed and volume of passenger trains; speed and volume of freight trains; accident history in the preceding 5 years; amount of road traffic and posted speed limit; the angle of the railroad and the roadway at the grade crossing; the distance to an alternative crossing; use of the crossing by trucks, school buses, and emergency vehicles; and type of warning device present at the crossing, among others. A complete state-by-state list of regulations was summarized by Jennings (2009).

**Table 2.9 Summary of Federal regulation related to grade crossing protection and closure (Federal Railroad Administration, 2012)**

<b>Maximum Passenger Train Speed</b>	<b>&gt; 79 mph (127 kph)</b>	<b>111-125 mph (179-201 kph)</b>	<b>&gt; 125 mph (201 kph)</b>
Grade Crossing Protection Type	Active	Warning/Barrier with FRA Approval	Grade Separate or Close

Regarding the grade-crossing accidents on conventional tracks, there is an enormous amount of probability modeling and prediction modeling available to predict the occurrence of grade-crossing accidents. Faghri and Demetsky (1986) reviewed and compared the predictability of several models, including the New Hampshire, the Peabody-Dimmick, NCHRP Report 50, and the USDOT model, and found that the USDOT model predicted the number of accidents for a specific grade-crossing the most accurately among the four models and have been the most commonly used model to predict grade-crossing accidents.

However, because of the generality of the DOT model, some research found that it may not accurately predict a grade-crossing accident under specific conditions (e.g., in a specific area). Benekohal and Elzohairy (2001) developed the Illinois Hazard Index to account for the regional characteristic of the state and arrived at a higher percentage of crossings in need for improvement. Austin and Carson (2002) developed a negative binomial regression model to address the concern that the USDOT model may lose its prediction accuracy over time due to the technology advances and ongoing grade-crossing safety improvement. Austin and Carson’s model not only addressed the concern but also simplified the model process without compromising its accuracy, though further formal validation is required. Oh et al. (2006) reviewed the aforementioned models and found that none of them fitted the observed data in South Korea, so they used the Gamma function to develop the prediction model for grade crossings in South Korea. Chaudhary (2011) compared the DOT model to a prediction model developed by Transport Canada and again found that the DOT model was more accurate in prediction in general, whereas the Transport Canada model could better predict for grade-crossings that have an accident history. Chadwick et al. (2012) examined FRA train accident databases and conducted statistical analyses to investigate factors that affect the train derailment

rate and severity of grade-crossing accidents. The results showed that highway vehicle size had a strong effect on the derailment rate at grade crossings. Chadwick et al. (2013) extended the study and developed a statistical model to depict grade-crossing accident probability. Chadwick et al. (2014) presented an overview of the challenges of grade crossings to shared HSR passenger and heavy-axle-load (HAL) freight operations in the U.S., as well as an in-depth analysis of the relevant research to date.

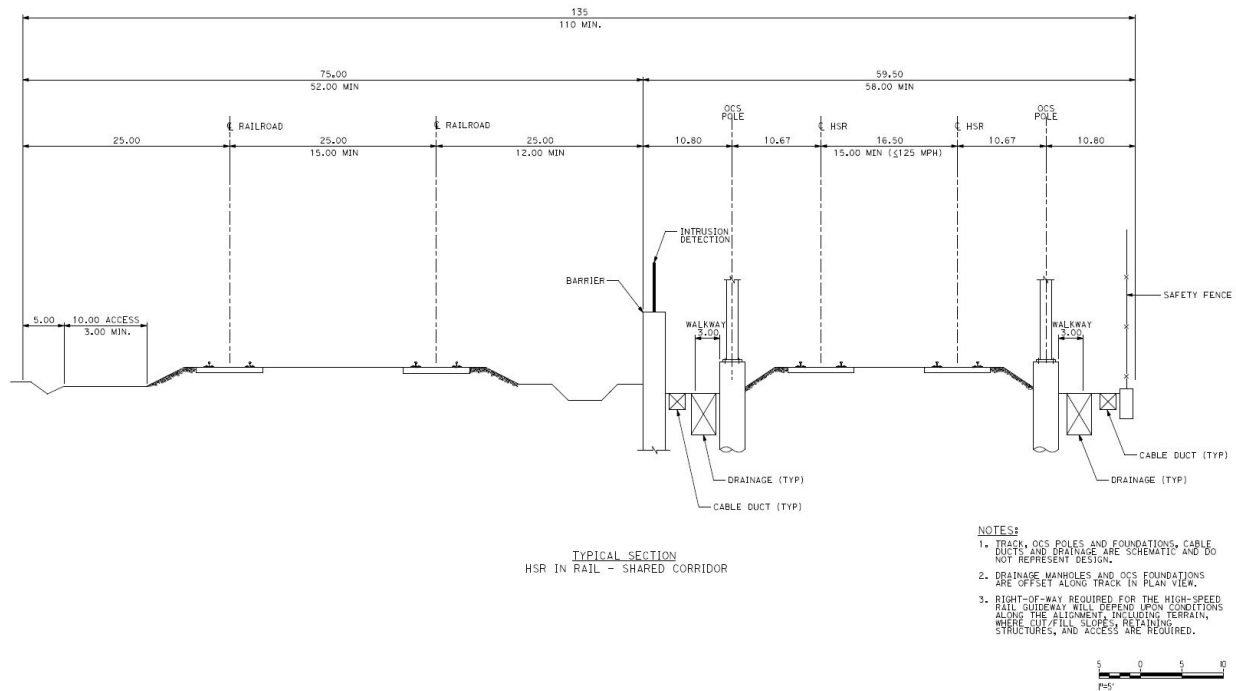
## **2.8 Drainage Problems Affecting Either HSR Track or Adjacent Track**

Drainage is arguably the most important item in the maintenance of track substructure. Almost all subgrade instability problems are due to excessive moisture (Hay, 1982). Poor drainage may cause the instability of railroad roadbed, track geometry irregularity, ballast fouling, and other substructure problems. These substructure defects may then lead to more severe crosstie deterioration, shorter life of track components, slow orders, and safety concerns (potential derailment risk). More strict standards are required for the operation of HSTs due to very high speed. Proper drainage is a very high priority for HSR tracks and contributes to good roadbed condition and track geometry.

Rulens (2009) specified that a 3-foot-wide area, the edge of which was located at least 3 feet from the overhead catenary system (OCS) pole center line, should be reserved on both sides of a double-track formation or on one side of a single-track formation for drainage purposes for construction in California HSR (Figure 2.22). Three types of drainage were recommended, in order of preference (Rulens, 2009):

1. Surface facilities, such as ditches, when there is no groundwater to be lowered
2. Open channel when space-saving is necessary or when groundwater level needs to be lowered
3. A completely buried system

When ditches were used, a minimum width of 2 ft. and 0.9-ft. drain diameters were recommended. As for the size of drainage pipes, a 24-in. average pipe size was recommended. When underdrains were laid in a trench, the width of the trench was the pipe diameter plus one foot. Excessive pipe size (more than 48 in. diameter) was not recommended, as the maintenance work would cause disturbances in traffic. When a conventional track and a HSR track are adjacent to each other, the drainage for both systems and their effect on individual system should be noted. Poor drainage on one track could create drainage problems on other tracks. Therefore, it is important to consider the substructure and subgrade characteristics of both systems when evaluating and/or constructing drainage systems in SRCs.

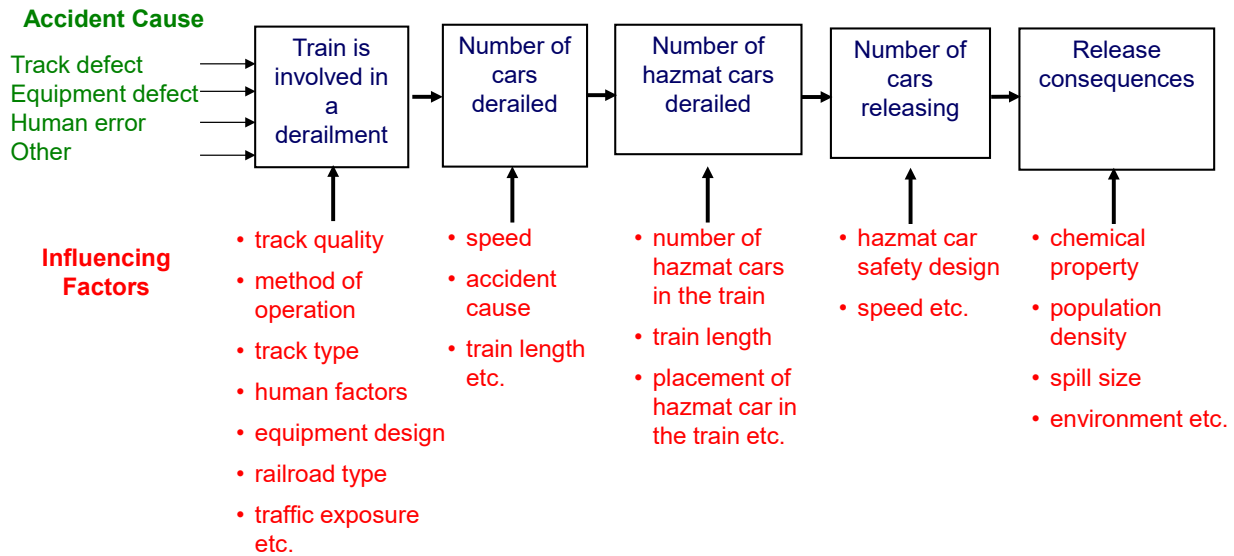


**Figure 2.22 Drainage design on HSR track under shared rail corridor setting (Rulens, 2009)**

## 2.9 Hazardous Materials on Adjacent Track

Transporting hazardous materials (or dangerous goods) on the railroad adjacent to HSR tracks poses additional risk to the HSR track due to the potential risk of the release of hazardous material from the freight cars on the conventional tracks. Although hazardous materials only account for a small amount of total rail traffic in the U.S., and more than 99 percent of shipments safely reach their destinations, it still represents a large portion of liability and insurance risk (Association of American Railroads, 2013) (Liu, 2013).

Most of the release of hazardous materials results from train derailments. Hazardous materials transportation risk assessment relies on the estimation of the probability and consequences of a release incident (Liu et al., 2014a). Each element in the sequence of events of a hazardous materials release incident is shown in Figure 2.23. The literature on derailment events has been reviewed in Section 2.2. This section reviews previous studies regarding the conditional probability of a release, given a derailment.



**Figure 2.23 Sequence of events leading to a hazardous materials release incident (Liu et al., 2014a)**

Treichel et al. (2006) used the Railway Supply Institute–Association of American Railroads (AAR) tank car accident database (TCAD) to develop a logistic regression model to estimate the conditional probability of a release from tank cars. Barkan et al. (2003) and Treichel et al. (2006) found a strong effect of speed on both derailment severity and release probability of hazardous materials tank cars derailed. Kawprasert and Barkan (2010) extended Treichel et al.’s analysis by accounting for the effect of derailment speed in estimating release probability. The conditional probability of release (CPR) of a derailed tank car is affected by both derailment speed and tank car design characteristics (Treichel et al., 2006) (Barkan, 2008) (Saat, 2009) (Kawprasert & Barkan, 2010) (Saat & Barkan, 2011). Liu et al. (2013) presented a linear regression model to estimate speed-dependent CPR for tank cars most commonly used to transport hazardous materials. Liu et al. (2013) further extended the study and developed a generalized model to evaluate the probability distribution of the number of tank cars released in a train derailment, accounting for specified operational characteristics.

## 2.10 Fire on Adjacent Track

Some fire scenarios on trains are the direct cause of accidents, including engine fire, pantograph fire, and human-caused fire. Other fire scenarios are the consequences of the hazards mentioned previously, such as the fire resulting from derailments (Section 2.2), collisions (Sections 2.2 and 2.6), leaked fuel and released hazardous materials (Section 2.9). Fire may directly cause passenger casualties, equipment and/or infrastructure damage, and lading loss. High temperature, smoke inhalation, or injuries due to the collapse of a structure could also occur. Fire on the adjacent track may result in hindered visibility, potential passenger casualties on the train, equipment damage, and a chain fire or explosion. Hence, although not common, fire is a potential hazard for railroad operations.

The National Institute of Standards and Technology (NIST) conducted a three-phase study on the fire safety of passenger trains. The first phase focused on an evaluation of the material used on passenger rail car interior components by obtaining the heat release rates (HRR) for different

materials on passenger rail cars by using small-scale test methods and the cone calorimeter test method (Peacock & Braun, 1999). The second phase used HRR data from phase one and applied that to fire hazard analysis techniques in order to acquire the design criteria for passenger car interior component design (Peacock et al, 2002). The third phase validated the passenger train fire safety design criteria developed in phase two by full-scale tests and fire hazard analyses using the Consolidated Model of Fire and Smoke Transport (CFAST) model (Peacock et al., 2004). Comparing the time to untenable conditions of interior components determined from experimental measurements with those calculated by the CFAST fire model showed excellent consistency. Note that the NIST research focused on car components instead of car structures. Thus, an evaluation of the fire endurance of floor or wall partitions and the impact of electrical wire and cable wires were not considered.

The Rail Safety and Standards Board (RSSB), an independent, non-profit organization responsible for the publication and maintenance for the British Railway Rule Book, develops rules and recommendations for the railways in the Great Britain. The RSSB (2013) divides passenger cars into four operation categories based on the minimum time required for a train to stop and the accessibility to an evacuation area. Each operation category corresponds to a different requirement and standard for car material property, which is produced by the British Standard Institution (1999). Some of the requirements and standards apply to multiple or all operation categories. These requirements and standards include fire resistance of car exterior and interior materials (wall, floor, ceiling, etc.), car components (doors, seats, lights, windows, etc.), fire and smoke detection systems, devices, materials, or any design that can reduce the ignition of fire and propagation of heat, smoke, and fire.

## **2.11 Evacuation of Passengers on Adjacent Track**

When a derailment, a collision, or a fire on a train occurs, an evacuation is needed to protect passengers. An effective and safe evacuation process can prevent potentially severe passenger injuries or fatalities. This is more important if hazardous conditions are present, such as fire or the release of hazardous materials, as discussed in previous sections. In addition, when an HSR track is adjacent to a conventional track, there is the potential risk of evacuated passengers or personnel inadvertently fouling the HSR track and being struck by an HST, and vice versa. Therefore, more comprehensive evacuation and training processes should be developed to address the evacuation process with an adjacent railroad system (i.e., coordination with the adjacent railroad systems to evacuate passengers [Federal Railroad Administration, 2011b]).

Current passenger rail equipment regulations related to emergency systems are specified in Title 49 Code of Federal Regulations (CFR) Parts 238, Passenger Equipment Safety Standards (Federal Railroad Administration, 2012) and 239, Passenger Train Emergency Preparedness (Federal Railroad Administration, 2011b). However, DOT agencies do not currently specify emergency evacuation time requirements for buses or passenger trains. Also, no methodology exists for evaluating the passenger rail car emergency egress system as a whole, or the effects on evacuation times of failures within systems.

FRA (2013) conducted a comprehensive and extensive literature review and analysis on the passenger train emergency system to evaluate various existing egress models for their capability to predict the time necessary to evacuate U.S. passenger rail cars under various emergency conditions. The authors also reviewed passenger car egress variables and passenger rail car



designs to determine their usefulness as data inputs to an egress computer model. They developed representative evacuation scenarios and identified necessary data inputs for modeling purposes. Some important takeaways were summarized below.

Table 2.10 shows a comparison of passenger rail car evacuation flow rates for different countries' railroad systems. The rates for traveling from a side door to a high platform or an end door to an adjacent car were similar for all systems, whereas the rates for other egress path routes varied from system to system. Note that the majority of passenger rail car egress experiment trials did not involve regular passengers as volunteer participants and did not consider the unique railroad operating environment (Federal Railroad Administration, 2013).

**Table 2.10 Comparison of passenger rail car evacuation flow rates (FRA, 2013)**

EGRESS PATH ROUTE	U.S. (Volpe / MBTA) (pps / ppm) <sup>#</sup>	UNITED KINGDOM (pps / ppm) <sup>#</sup>	AUSTRIA (pps / ppm) <sup>#</sup>	SPAIN (pps / ppm) <sup>#</sup>
Side door to high platform or end door to adjacent car <sup>##</sup>	0.9 / 52	0.7–0.9 / 43–55	~1 / 62	-
Side door to tunnel side platform walkway <sup>###</sup>	-	-	-	0.6 / 34
Side-door stairway to low platform <sup>####</sup>	0.7 / 41	-	-	-
Side-door stairway to ROW <sup>#####</sup> and platform <sup>#####</sup>	0.3 / 20	-	~1 / 62-	-

<sup>#</sup> All numbers have been rounded.

<sup>##</sup> Noncompetitive / competitive.

<sup>###</sup> 9.8-in (25-cm) height from door threshold to platform and 15.7-in (40-cm) gap from door threshold to platform.

<sup>####</sup> 15-in (38-cm)-height difference from bottom of last step of side-door stairway to pavement.

<sup>#####</sup> 25-in (63.5-cm)-height difference from door threshold to platform.

<sup>#####</sup> 26-in (65-cm)-height difference from bottom of last step to track level.

The following factors that affect passenger train evacuating time were identified:

1. Passenger characteristics
2. Rail car geometry and configuration
3. Operating environment (including fire, discussed in the previous section)
4. Train crew (and emergency responder) training
5. Passenger awareness
6. Assistance to passengers in exiting
7. Assistance from emergency responders

The challenge of conducting a valid test of people's behavior is how to create a realistic test without putting individuals at the risk of an actual injury. In addition, individual physical conditions and physical obstacles have a significant impact on the amount of time necessary for people to exit from a passenger rail car. Accordingly, the use of models that simulate egress behavior could reduce the number of actual experiments.



Several methods and computer models used to establish transportation vehicle occupant egress time were reviewed. The hand-calculation hydraulic method and the hydraulic and individual-movement model typically used passenger density, effective aisle width, pitch of stairs, etc., and had been accepted for use in building egress time estimates. However, the application of these methods directly to passenger rail car egress was problematic because different methods estimated different evacuation rates and times, and the widths of aisles and pitches of passenger rail car stairways were different from those in buildings. None of the building models have been validated using actual passenger rail car occupant data. Hence, FRA funded the development of a new prototype passenger rail car egress computer model by the University of Greenwich, U.K. This model used data from the Volpe Center's experiment in 2005 and 2006, combined with known physical characteristics of the rail car and the operating environment at the time the data was recorded, to validate passenger rail car egress time predictions generated by the new prototype model. A more detailed literature review and discussion can be found in the FRA (2013) report.

In addition, FRA (2006) constructed an Emergency Evacuation Simulator (the "Rollover Rig") for passenger cars to simulate rail car positions after derailments or other rail accidents (Figure 2.23). The simulator was intended for use as a training tool by emergency response organizations, and for equipment designers to evaluate different types of emergency equipment.



**Figure 2.24 Emergency Evacuation Simulator ("Rollover Rig") (FRA, 2006)**

RSSB (2013) mandates several criteria for passenger rail car design in order to meet emergency evacuation requirements. The passenger car design should allow the following evacuation rate.

- Side evacuation: All passengers should be evacuated to platform level in less than 90 seconds.
- End evacuation: A minimum passenger flow rate should be at least 30 passengers per minute.
- Car-to-car evacuation: All passengers should be evacuated to adjacent cars in less than 90 seconds; if the car is at the end, the minimum passenger flow rate to the adjacent car should be at least 40 passengers per minute.

An additional assumption for car-to-car evacuation is that the adjacent car(s) is empty.

The underlying assumptions are the car is fully loaded and the time to open the side/end doors is excluded. For side evacuation, no passenger seat in a passenger parlor or location where a passenger may be expected to be in a side corridor should be further than 12 m (39 feet) from a body-side door or a body-side emergency exit on both sides of the car. Passenger and staff accommodation with a plan view of 4 m<sup>2</sup> (43 ft<sup>2</sup>) should have at least two separate exits.

## **2.12 Electromagnetic Interference between Trains and Wayside Equipment on Adjacent Tracks**

Hadden et al. (1992) first identified electromagnetic interference (EMI) as one of the safety concerns for the operation of HSR and maglev train systems. EMI is the electromagnetic field generated by a source (e.g., a HST or high-voltage power tower) that negatively affects electrical or magnetic devices. EMI in this section specifically refers to those that adversely affect the operation of HSR near wayside equipment on adjacent tracks. The potential sources of EMI include but are not limited to: motors on passing trains on adjacent tracks, overhead catenary wires, and power facilities along the tracks.

In the 1992 study, most of the EMI scenarios were developed for Maglev train systems. The only concern regarding the EMI effect on adjacent railroad systems was the disturbance of the signaling and train control system, which may lead to the malfunction of the signal display or switches. An HSR system may generate similar electromagnetic fields that could disturb the signaling system on an adjacent railroad. This scenario could lead to a conventional train on the adjacent track missing a stop signal and colliding with another train. In addition, due to the lack of information on the nature and extent of how the electromagnetic field affects health, the study only addressed the effect of electromagnetism on equipment. Later, Creasey and Goldberg (1993) and Farag et al. (2003) studied the potential health effects of EMI.

Dietrich and Jacobs (1996) conducted a survey and risk assessment on EMI public exposure in different transportation systems, including commuter train systems. They found that the major source of EMI was the pantograph and the high-voltage overhead catenary system.

Niska (2009) conducted a series of research to investigate EMI in Swedish railway systems. Similar to the FRA study, the major safety concern was the EMI effect on signal failure, false signal transmission to switch movements, or false reporting of infrastructure defects (Niska, 2004, 2008a, 2008b, 2009). About 70 percent of signal failures, false signal transmissions to switch movements, or false reports of defect detectors could have resulted from EMI (Niska, 2009).

Morant et al. (2012) investigated the impact of EMI on train operation and environment. One of the results showed that the starting of a train creates EMI on the signal system, causing it to fail, thus bringing the train to an emergency stop.

CHSRA (2012) conducted an analysis regarding the EMI effect on the operation of future True HSR in California as part of an environmental impact evaluation. The report mentioned two possible scenarios for EMI from HSR systems to adjacent conventional railroads:

1. *“The high electrical currents flowing in the OCS and the return currents in the overhead negative feeder, HST rails, and ground could induce 60-Hz voltages and currents in existing parallel railroad tracks. If an adjoining freight railroad track parallels the HST tracks for a long enough distance (i.e., several miles), the induced voltage and current in*

*the adjoining freight railroad tracks could interfere with the normal operation of the signal system, thereby indicating that there is no freight train present when, in fact, a train is present, or thereby indicating that a train is present when, in fact, no train is present.”*

2. *“Higher frequency EMI from several HST sources (electrical noise from the contact on the pantograph sliding along the catenary conductor, from electrical equipment onboard the HST, or from the cab radio communication system) could cause electrical interaction with the adjoining freight railroad signal or communication systems.”*

## **3. Hazard Prioritization and Mitigation Strategies**

---

### **3.1 Introduction**

In order to assist the prioritization of the aforementioned hazards associated with HSR operation adjacent to conventional railway, the study team conducted two industry surveys. The first survey was conducted between April 4, 2014, and May 10, 2014. The main objective of the survey was to determine which hazards were most important and in need of further in-depth research. Participation in the survey was solicited from members of the American Railway Engineering and Maintenance-of-Way Association (AREMA), Committee 17—High Speed Rail Systems, via email. There were 15 total participants in the survey out of approximately 70 people contacted. The 21 percent response rate is better than the average 10 percent–15 percent response rate for typical external surveys. In addition, although it was optional for the survey participants to provide names and contact information, the list and additional communication shows that key contacts have been included, providing perspectives from the California HSR Project, Amtrak’s Northeast Corridor, at least one Class I freight railroad, and multiple state rail planners. The second survey was conducted between December 29, 2014 and February 15, 2015. The main objective of the second survey was not only to determine which hazard was most important but also to collect intelligence and experiences from international stakeholders. There were 10 total participants in the second survey, including consultants from UK, France, and Canada. The second survey intended to collect the current practices of SRCs and related safety measurements from other countries.

Participants in both surveys were asked to rate the 11 hazards on scale of 1 to 5, with 5 representing high importance or potentially high risk and 1 being the lowest importance or potentially low risk. Final scores for each hazard were computed by averaging the scores from all participants.

### **3.2 Hazard Prioritization**

Based on the surveys, the completed literature review, and the study team’s collective knowledge, the following top-priority hazards were identified (listed in decreasing order of importance):

1. Derailment on adjacent track
2. Shifted load on an adjacent track
3. Obstruction hazard resulting from an adjacent track (including non-derailment and grade-crossing collisions)
4. Intrusion of maintenance-of-way staff and equipment working on the adjacent track
5. Hazardous materials on the adjacent track

Identified key factors affecting the severity of the high-priority hazards include:

- Track and ROW spacing between adjacent railroad tracks
- Speeds of both the HSR and conventional operations
- FRA track class (representing track quality and maintenance standards)
- Train control and signaling systems
- Existence of adjacent structures
- Use of physical barriers or containment

### 3.3 Potential Risk Mitigation Strategies

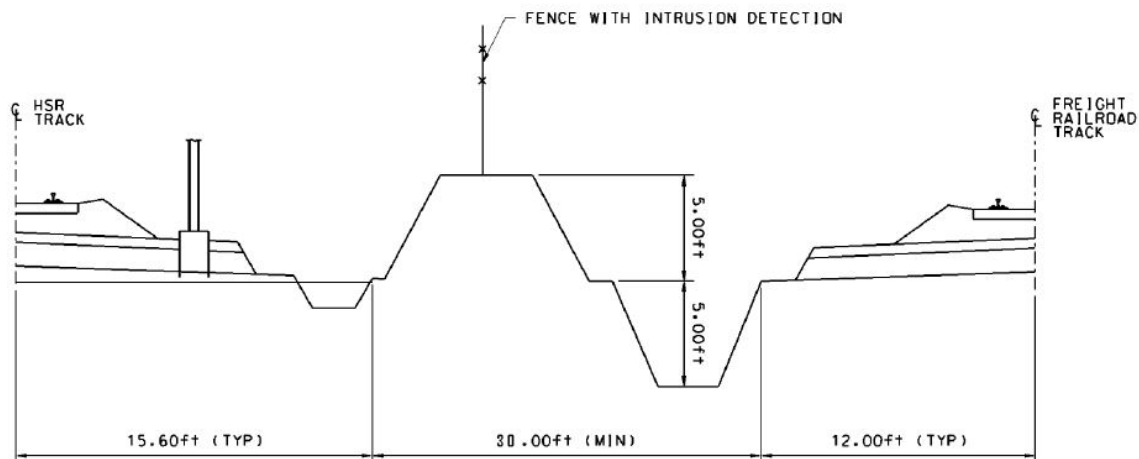
Based on the literature review and the input from survey participants, this section discusses the following list of potential risk mitigation strategies for the aforementioned high-priority hazards. Each risk mitigation strategy is individually introduced, and its technical feasibilities, cost and institutional constraints, and/or other requirements are discussed.

#### 3.3.1 Increase Track Center Spacing

Adequate track center spacing keeps HSR track and conventional track far enough apart so that the likelihood of an intrusion from derailed equipment, shifted load, obstructions, and intrusion of MOW staff and equipment is low. Abtahi (2013) conducted a study of intrusion protection for the California High-Speed Rail system. In addition, some literature found in previous sections may provide information for track spacing selection (English et al., 2007; Cockle, 2014). A more comprehensive risk assessment model, however, is required to determine adequate track spacing. Increasing track spacing is technically feasible, especially if considered during the initial planning of a new HSR line and if there is available space or ROW. Additional ROW to accommodate an alignment with multiple main tracks and sufficiently wide track centers may result in significantly higher costs, depending on the location and amount of ROW required.

#### 3.3.2 Install Intrusion Detection System

An intrusion detection system detects the intrusion of derailed equipment or MOW equipment from an adjacent track. The system is able to set the signal controlling the track block to stop after an intrusion is detected in order to prevent trains from running into the intruded track block. The system also warns the engineer about an intrusion if the system is integrated with an onboard signaling and information display system on the train. Figure 3.1 shows an example of the intrusion detection system—a fence with sensors is installed between the HSR track and the conventional track. The intrusion detection system is technically feasible for both existing and newly built shared operation settings. The total cost of such a system depends on the length of the track segments where intrusion detection sensors are installed.



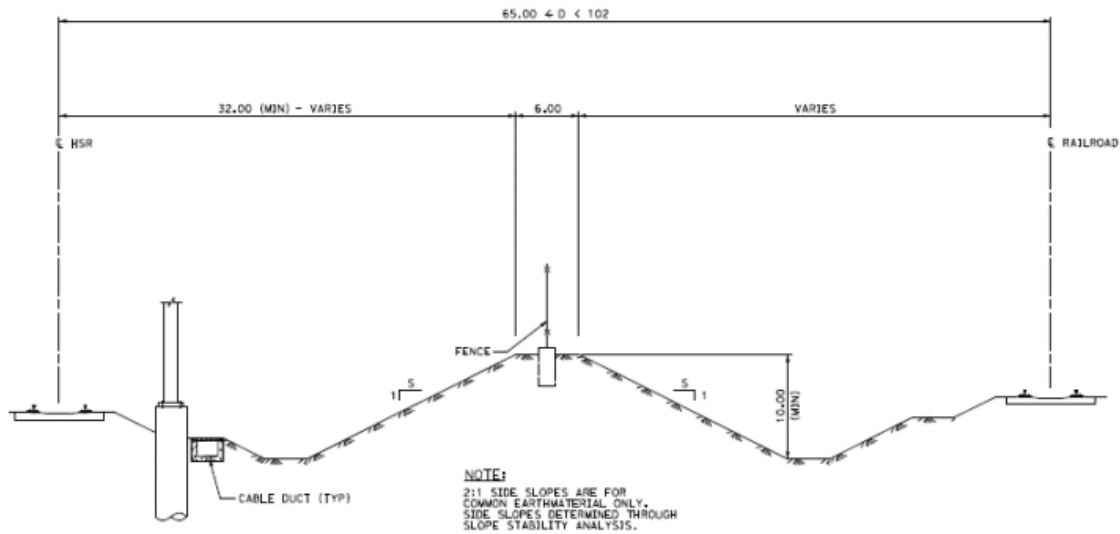
**Figure 3.1 The installation of the intrusion detection system (Abtahi, 2013)**

### **3.3.3 Upgrade Track Class & Increase Maintenance Standards**

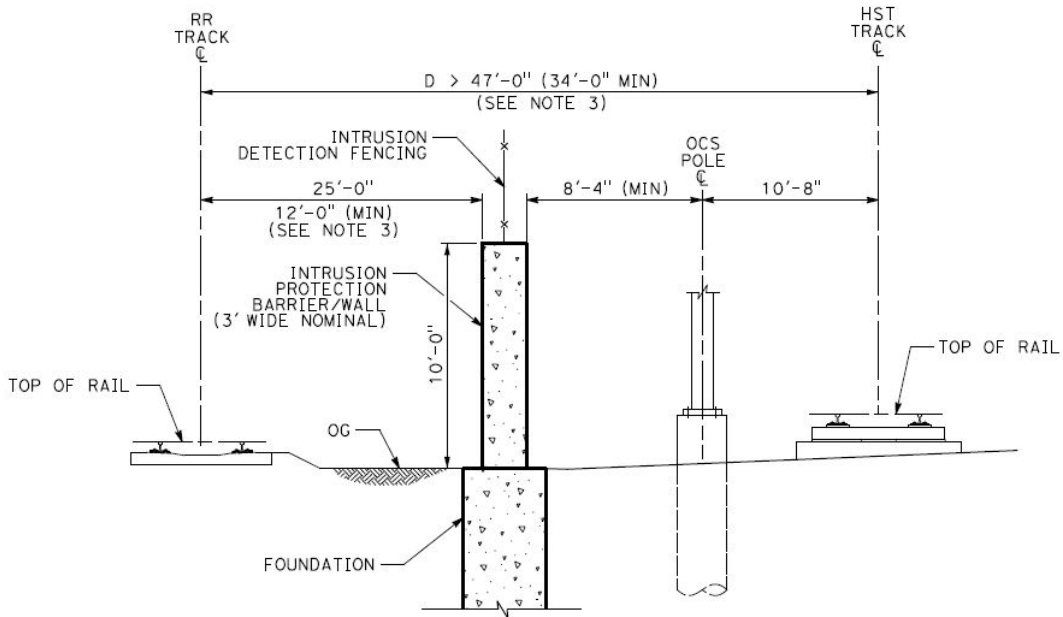
FRA track class has been used as a proxy for track quality and as a parameter for estimating derailment rate (Liu, 2011). Generally, the higher the track class, the lower the derailment risk (Nayak, 1983) (Anderson & Barkan, 2004) (Liu et al., 2011). Upgrading track class refers to the improvement of track quality, more stringent maintenance standards, and more frequent track inspection. This may reduce the train derailment rate and thus reduce the risk of intrusions and the potential consequences. It can also mitigate a shifted load hazard because of better track geometry and thus less lateral or vertical acceleration. Upgrading track class is technically feasible for both existing and newly built shared operation settings. In newly built shared operation settings, existing conventional tracks can be upgraded to reduce derailment risk. Increasing inspection standards (including both frequency and quality) helps to reduce certain types of train derailments (e.g., broken rail derailments) (Liu et al., 2014b). The effect of risk reduction by upgrading infrastructure can be weighed against the cost of upgrading infrastructure (Liu et al., 2010). Lovett (2013) developed a model to evaluate rail maintenance planning, considering the benefit (reduced derailment risk) and cost (machine/labor cost and potential train delay). One institutional issue regarding upgrading the track class is that the adjacent railroad may not be in favor of upgrading the track class if not absolutely necessary (due to higher maintenance and inspection costs), particularly if the traffic level on the adjacent track is low. This will require buy-in from the adjacent railroads.

### **3.3.4 Install Crash Wall (between HSR track and conventional track)**

Crash walls are the physical barriers that can be built between HSR tracks and conventional tracks to prevent the intrusion of derailed equipment. Typical crash wall types include earthwork barriers (Figure 3.2), structural barriers (Figure 3.3), and a combination of both. Another type of barrier is the pier protection barrier, built between the railroad and the pillar of an overpass bridge of a roadway or another railroad. Moyer et al. (1994) performed a comprehensive and detailed study on the intrusion barriers of HSR systems. The study discussed and analyzed barrier types and their functions, proper barrier offset distance, barrier design, barrier costs, hazard assessment, and hazards that may be prevented by installing barriers. The study suggested using structural barriers (e.g., a concrete crash wall) instead of earthwork barriers for the HSR and adjacent conventional railroad systems. The typical height of the barrier is 10 feet. The study also suggested the distance from the train to barriers should be either less than 9 feet or greater than 40 feet to address the “zig-zag” effect. Abtahi (2013) suggested that both structural barriers and earthwork barriers could be used, but each of them should be applied with different track spacings between HSR track and conventional railroad track. The suggested minimum track spacing for the implantation of earthwork barriers (76 feet) is larger than that of structural barriers (47 feet). As for pier protection, Abtahi (2013) suggested the minimum offset between a HSR track and the pier should be 25 feet, based on AREMA recommendations. Otherwise, a crash wall or barrier should be built to protect the pier. Installing a crash wall is technically feasible for both existing and newly built shared operation settings. The installation of a crash wall requires space between two tracks. In addition, the total cost is expected to be high, and it is a function of the type and length of the installation.



**Figure 3.2 Earthwork barrier protection (Abtahi, 2013)**



**Figure 3.3 Structural barrier protection (Abtahi, 2013)**

### 3.3.5 Install Train Containment

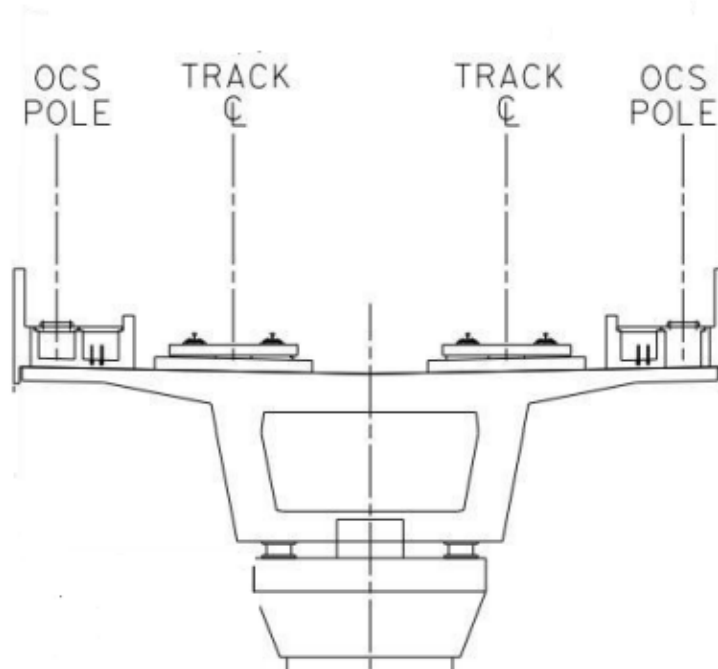
Train containment is designed to prevent a HST or conventional train from overturning or deviating away from its own track. Typical containment includes guard rails, parapets, and undercar guards. A guard rail is installed to contain rolling stock and prevent it from intruding the adjacent track when it derails (Figure 3.4). A parapet serves the same function; but instead of putting the containment inside the track, parapet is installed along the track (Figure 3.5). An

undercar guard is a containment device installed under a rail car axle inside its wheel, so that when derailment occurs, the containment would contact the gauge side of the rail and prevent the wheel from rolling away from the track (Figure 3.6). Installing train containment has been a common practice in Europe (e.g., the Channel Tunnel Rail Link). Specific locations which have a relatively higher derailment risk are chosen for containment installation, such as bridges, switches, and interlockings. Installing train containment is technically feasible for both existing and newly built shared operation settings. The containment can be installed on both HSR tracks and conventional tracks. The cost of containment depends on the type of containment and the length of containment.

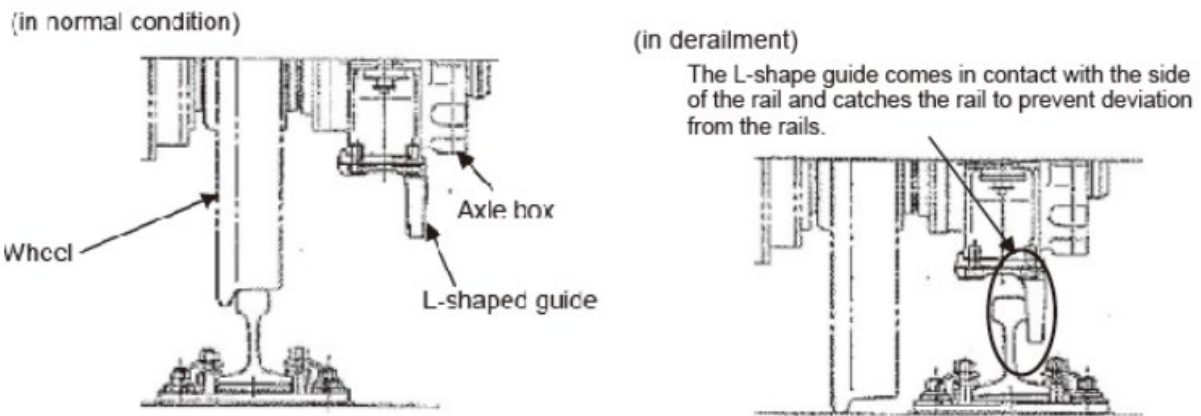


**Figure 3.4 Guard rail protection (Abtahi, 2013)**





**Figure 3.5 Parapet protection (Abtahi, 2013)**



**Figure 3.6 Undercar guard protection (Abtahi, 2013)**

### **3.3.6 Install Shifted Load Detector**

A shifted load detector is a wayside detector to detect a shifted load on passing trains. The cost of a shifted load detector depends on the number of detectors installed along the railroad line. Negotiation will be required with freight railroads to install the shifted load detector.

### **3.3.7 Install Enhanced Grade-Crossing Protection/Detection Systems**

Grade-crossing obstacle detection is defined by Glover (2009) as systems used in “identifying the presence of a vehicle or person on the crossing as the train approaches and communicating

this to the train driver in time for him or her to stop before reaching it.” Grade-crossing protection includes four-quadrant gates, train approaching warning devices, long-arm gates, and traffic channelization devices. Figure 3.7 shows an example of a combination of several grade-crossing protection/detection systems. Chadwick et al. (2014) conducted a comprehensive and extensive literature review on the challenges of grade crossings to shared HSR passenger and heavy-axle-load freight operations in the U.S. Some risk mitigation strategies are proposed and reviewed, including obstacle detection, traffic channelization, and grade-crossing warning devices. These can serve as the basis for future research directions.



**Figure 3.7 An upgraded grade-crossing with four-quadrant gates, train approaching warning devices, and traffic channelization devices (Bien-Aime, 2009)**

### ***3.3.8 Install Obstruction Detection Systems (non-grade-crossing zone)***

Obstruction detection systems are defined by extending Glover’s (2009) definition to the “obstacle detection” as “identifying the presence of a vehicle or person on the track as the train approaches and communicating this to the train driver in time for him or her to stop before reaching it.”

### ***3.3.9 Install Inter-track Barrier for Workers’ Protection***

An inter-track barrier is a continuous barrier of a permanent or semi-permanent nature that spans the entire work area with at least 4 feet in height and of sufficient strength to prevent a roadway worker on conventional railroad track from fouling the adjacent HSR track (Federal Railroad Administration, 2014) or vice-versa. As summarized in Table 2.8 and Figure 2.21 in section 2.6, with the protection of an inter-track barrier, a maintenance crew can continue working without waiting for a passing train. This may reduce maintenance time and increase railroad efficiency. Installing an inter-track barrier is technically feasible for both existing and newly built shared operation settings. The cost of an inter-track barrier depends on its length.

### **3.3.10 Increase Situational Awareness**

Reinforced situational awareness is achieved by educating railroad employees to be more aware of the surrounding environment when working on the ground, especially when there are adjacent tracks.

### **3.3.11 Use Enhanced Tank Car Safety Design**

Improved tank car safety design reduces the conditional probability of the release of hazardous materials from a tank car if it derails by increasing tank car thickness, adding top fitting protection, jacketing, additional head protection, and an anti-climb coupler. Numerous studies quantitatively address the effect of tank car safety design on reducing release risk. The results of these studies, combined with other risk mitigation strategies, can provide information on how to effectively mitigate the risk posed by transporting hazardous materials on tracks adjacent to a HSR system.

### **3.3.12 Increase Passenger Cars' Crashworthiness**

Equipment strength is a key factor for reducing potential casualties onboard passenger cars from a derailment and/or collision impact. Crashworthiness analyses have been conducted for higher-speed passenger trains (Tier I standard) (Carolan et al., 2011) to understand how reinforced equipment can withstand a larger collision impact and thus result in fewer casualties. Full-scale experiments have been conducted and results have been analyzed to provide levels of crashworthiness for future reference on regulations for the crashworthiness of higher-speed passenger equipment.

### **3.3.13 Implementing Temporal Separation**

Temporal separation refers to the spatial or time separation for the operations of HSR trains and conventional trains. For example, when practical, freight trains transporting hazardous materials could only operate at night, so that they are separated from HSTs, or hazardous traffic could be rerouted away from the tracks adjacent to HSR tracks. Temporal separation can completely eliminate certain hazards, such as hazardous materials transportation on adjacent tracks, but additional cost may incur due to higher transportation costs for freight (due to rerouting) or inefficient use of line capacity (due to time separation). In addition, communication between HSR operators and conventional railroad agencies is required to reach an agreement on temporal separation. Generally, temporal separation is technically feasible on the corridors where there is only limited train traffic on adjacent conventional tracks or HSR tracks.

### **3.3.14 Increase Training on Load Securement**

Load securement training educates railroad personnel on how to firmly secure a load so that the load will not be displaced by acceleration forces to prevent it from shifting or detaching from the freight car. Training should include either railroad employees who are in charge of loading and contractors or customers who load the cargo themselves before transportation by railroads.

Note that although the suggested risk mitigation strategies and their advantages and disadvantages are introduced individually, combinations of different risk strategies are feasible. It is a common practice to combine two or more risk mitigation strategies, and sometimes their

effects will be greater than implementing an individual strategy at the same amount of cost. For example, when a containment structure or a crash wall exists between two tracks, intrusion detection sensors can either be attached to the containment structure or crash wall, or they can be installed with a fence built atop the containment or crash wall, depending on the height of the containment or crash wall and the physical layout of the track segment. Hence, when evaluating the effect of risk mitigation strategies, an integrated risk assessment model is required to consider multiple risk mitigation strategies and their effects together.

Almost all the risk mitigation strategies require additional cost. With limited resources and budgets, properly selecting and implementing risk mitigation strategies to achieve safety in a cost-effective way is essential. Therefore, a comprehensive model is required to evaluate the risk of hazards associated with the operation of HSR adjacent to conventional railroad. Further research, analyses, and models for individual hazards and corresponding potential risk mitigation strategies are also required for better understanding the hazards and preparation of integrating all of the factors considered.

## 4. Conclusion

---

This report presents a comprehensive literature review of several hazards associated with HSR operations adjacent to conventional railways. It also discusses the prioritization of the importance of selected hazards associated with HSR operations adjacent to conventional railways. Derailment on adjacent tracks, a shifted load on an adjacent track, obstruction hazards resulting from an adjacent track (non-derailment and grade-crossing collisions), intrusion of MOW staff and equipment working on adjacent track, and hazardous materials on adjacent track have been identified as the high-priority hazards. Potential risk mitigation strategies for those hazards were also identified. Future work may include development of a risk model to identify and quantify the risk associated with high-priority hazards and an evaluation of the effectiveness of the risk mitigation strategies.

## 5. References

---

- Abtahi, A. (2013). Rolling Stock and Vehicle Intrusion Protection for High-Speed Rail and Adjacent Transportation Systems. Publication TM 2.1.7. New York: Parsons Brinckerhoff.
- Anderson, R. T., & Barkan, C. P. L. (2004). Railroad accident rates for use in transportation risk analysis. *Transportation Research Record: Journal of the Transportation Research Board*, 1863, 88–98.
- Association of American Railroads. (2013). [Railroads and Chemicals](#).
- Austin, R. D., & Carson, J. L. (2002). An alternative accident prediction model for highway-rail interfaces. *Accident Analysis & Prevention*, 34(10), 31–42.
- Barkan, C. P. L., Dick, C. T., & Anderson, R. T. (2003). Analysis of railroad derailment factors affecting hazardous materials transportation risk. *Transportation Research Record: Journal of the Transportation Research Board*, 1825, 64–74.
- Barkan, C. P. L., (2008). Improving the design of higher-capacity railway tank cars for hazardous materials transport: optimizing the trade-off between weight and safety. *Journal of Hazardous Materials*, 160, 122–134.
- Benekohal, R. F., & Elzohairy, Y. M. (2001). A New Formula for Prioritizing Railroad Crossings for Safety Improvement. In *Proceedings of the Institution of Transportation Engineers Annual Meeting*, Chicago, IL.
- Bi, H. Q., Lei, B., & Zhang, W. H. (2006). Numerical Study of the Pressure Load Caused by High-speed Passing Maglev Trains. *Acta Aerodynamica Sinica*, 24(2), 213–217.
- Bien-Aime, P. (2009). North Carolina "Sealed Corridor" Phase I, II, and III Assessment. Technical Report DOT/FRA/ORD-11/22. Washington, DC: U.S. Department of Transportation, Federal Railroad Administration.
- Bing, A. J. (1990). [An Assessment of High-Speed Rail Safety Issues and Research Needs](#). Technical Report DOT/FRA/ORD-90/04. Washington, DC: U.S. Department of Transportation, Federal Railroad Administration.
- Bing, A. J. (1993a). [Collision Avoidance and Accident Survivability Volume 1: Collision Threat](#). Technical Report. DOT/FRA/ORD-93/02.I. Washington, DC: U.S. Department of Transportation, Federal Railroad Administration.
- Bing, A. J. (1993b). [Collision Avoidance and Accident Survivability Volume 4: Proposed Specification](#). Technical Report. DOT/FRA/ORD-93/02.IV. Washington, DC: U.S. Department of Transportation, Federal Railroad Administration.

- British Standards Institution. (1999). Code of practice for fire precaution in the design and construction of passenger carrying trains. Publication BS 6852:1999. London: British Standards Institution.
- California High-Speed Rail Authority. (2012). California High-Speed Train–Project Environmental Impact Report (EIR) / Environmental Impact Statement (EIS)–Merced to Fresno Section Project EIR/EIS. Sacramento, CA: California High-Speed Rail Authority.
- Carolan, M., Jacobsen, K., Llana, P., Severson, K., Perlman, B., & Tyrell, D. (2011). [Technical Criteria and Procedure for Evaluating the Crashworthiness and Occupant Protection Performance of Alternatively Designed Passenger Rail Equipment for Use in Tier I Service](#). Technical Report. DOT/FRA/ORD-11/22. Washington, DC: U.S. Department of Transportation, Federal Railroad Administration.
- Chadwick, S. G., Saat, M. R., & Barkan, C. P. L. (2012). Analysis of factors affecting train derailments at highway-rail grade crossings. In *Proceedings of the Transportation Research Board 91st Annual Meeting*, Washington, DC.
- Chadwick, S. G., Dick, T. C., Saat, M. R., & Barkan, C. P. L. (2013). Statistical Modelling of Freight Train Derailments at Highway-Rail Level Crossings. In *2013 World Congress on Railway Research*, Sydney, Australia.
- Chadwick, S. G., Zhou, N., & Saat, M. R. (2014). Highway-rail grade crossing safety challenges for shared operations of high-speed passenger and heavy freight rail in the U.S. *Safety Science*, 68, 128–137.
- Chaudhary, M., Hellman, A., & Ngamdung, T. (2011). [Railroad Right of Way Incident Analysis Research](#). Technical Report DOT/FRA/ORD-11/09. Washington, DC: U.S. Department of Transportation, Federal Railroad Administration.
- Cockle, J. (2014). Freight Railroads Adjacent to High-Speed Rail–Assessing the Risk. In *Proceedings of the Joint Rail Conference*, Colorado Springs, CO.
- Creasey W. A., & Goldberg, R. B. (1993). [Safety of High-Speed Guided Ground Transportation Systems; Potential Health Effects of Low Frequency Electromagnetic Fields Due to Maglev and Other Electric Rail Systems](#). Technical Report DOT/FRA/ORD-93/31. Washington, DC: U.S. Department of Transportation, Federal Railroad Administration.
- Dawn, T. M. (1983). Ground Vibrations from Heavy Freight Trains. *Journal of Sound and Vibrations*, 87, 351–356.
- Dick, C. T., Barkan, C. P. L., Chapman, E., & Stehly, M.P. (2003). A multivariate statistical model for predicting the occurrence and location of broken rails. *Transportation Research Record: Journal of the Transportation Research Board* 1825, 64–74.
- Dietrich, F. M., & Jacobs, W. L. (1996). Survey and Assessment of Electric and Magnetic Field (EMF) Public Exposure in the Transportation System. Publication PB99-130908. State College, PA: Electric Research and Management Inc.

- English, G. W., Highan, G., & Bagheri, M. (2007). Evaluation of Risk Associated with Stationary Dangerous Goods Railroad Cars. Glenburnie, ON: TranSys Research Ltd.
- European Commission. (2009). European Best Practice Guidelines on Cargo Securing for Road Transport.
- European Committee for Standardization. (2010). Load Restraining on Road Vehicles–Safety–Part 1: Calculation of Securing Forces. Publication EN 12195-1:2010.
- Faghri, A., & Demetsky, M. J. (1986). Evaluation of Methods for Predicting Rail-Highway Crossing Hazards. Charlottesville, VA: Virginia Highway & Transportation Research Council.
- Farag, A. S., Hussain, H., Said, I., Kader, M. A., & Rahman, N. A. (2003). Electromagnetic Fields Associated with Transportation Systems in Malaysia. In *Proceedings of the International Conference on Non-Ionizing Radiation*, Selangor, Malaysia.
- Federal Railroad Administration. (2004). Notice of Safety Advisory 2004–01. Federal Register, Volume. 69, No. 85. Washington, DC: U.S. Department of Transportation.
- Federal Railroad Administration. (2006). [Passenger Rail Car Evaluation Evacuation Simulator](#). Research Results RR06-07. Washington, DC: U.S. Department of Transportation, Federal Railroad Administration.
- Federal Railroad Administration. (2009). [Highway-Rail Grade Crossing Guidelines for High-Speed Passenger Rail](#). Washington, DC: U.S. Department of Transportation, Federal Railroad Administration.
- Federal Railroad Administration. (2011a). Title 49 Code of Federal Regulation Part 214–Railroad Workplace Safety; Adjacent-Track On-Track Safety for Railroad Way Workers; Final Rule. Federal Register, Volume. 76, No. 230. Washington, DC: U.S. Department of Transportation, Federal Railroad Administration.
- Federal Railroad Administration. (2011b). Title 49 Code of Federal Regulation Part 239–Passenger Train Emergency Preparedness. Washington, DC: U.S. Department of Transportation, Federal Railroad Administration.
- Federal Railroad Administration. (2012). Title 49 Code of Federal Regulation Part 238–Passenger Equipment Standard. Washington, DC: U.S. Department of Transportation, Federal Railroad Administration.
- Federal Railroad Administration, (2014). Title 49 Code of Federal Regulation Part 214–Railroad Workplace Safety; Adjacent-Track On-Track Safety for Railroad Way Workers, Volume. 79, No. 7. Washington, DC: U.S. Department of Transportation, Federal Railroad Administration.
- Federal Motor Carrier Safety Administration. (2002). [Cargo Securement Rule](#). Washington, DC: U.S. Department of Transportation, Federal Motor Carrier Safety Administration.



- Fujii, K., & Ogawa, T. (1995). Aerodynamics of High-Speed Trains Passing by Each Other. *Computers & Fluids*, 24(8), 897–908.
- Galganski, R. A. (1993). [Collision Avoidance and Accident Survivability Volume 3: Accident Survivability](#). Technical Report DOT/FRA/ORD-93/02.III. Washington, DC: U.S. Department of Transportation, Federal Railroad Administration.
- Glover, J. (2009). The Level Crossing Conundrum. *Rail Professional* (November), 30–31.
- Hadden, J., Lewalski, W., Kerr, D., & Ball, C. (1993). [Safety of High-Speed Guided Ground Transportation Systems: Shared Right-of-Way Safety Issues](#). Technical Report DOT/FRA/ORD-92/13. Washington, DC: U.S. Department of Transportation, Federal Railroad Administration.
- Hanson, C. E., Towers, D. A., & Meister, L. D. (2006). [Transit Noise and Vibration Impact Assessment](#). Technical Report DOT/FRA/ORD-12/15. Washington, DC: U.S. Department of Transportation, Federal Railroad Administration.
- Hanson, C. E., Ross, J. C., & Towers, D. A. (2012). [High-Speed Ground Transportation Noise and Vibration Impact Assessment](#). Technical Report DOT/FRA/ORD-12/15. Washington, DC: U.S. Department of Transportation, Federal Railroad Administration.
- Harrison, J., et al. (1993). [Collision Avoidance and Accident Survivability Volume 2: Collision Avoidance](#). Technical Report DOT/FRA/ORD-93/02.II. Washington, DC: U.S. Department of Transportation, Federal Railroad Administration.
- Hermanns L., Gimenez, J. G., & Alarcon, E. (2005). Efficient Computation of the Pressures Developed During High-Speed Train Passing Events. *Computers and Structures*, 83(10), 793–803.
- Holmes, S., Toma, E., & Schroeder, M. (2000). High-Speed Passenger and Intercity Train Aerodynamic Computer Modeling. In *Proceedings of: The 2000 International Mechanical Engineering Congress & Exposition*, Orlando, FL.
- Hay, W. W. (1982). *Railroad Engineering* (2<sup>nd</sup> ed.). New York: Wiley.
- Jennings, L. S. (2009). *Compilation of State Laws and Regulations Affecting Rail-Highway Grade Crossings* (5<sup>th</sup> ed.) Woodstock, VA: Jennings Consulting Group.
- Jones, C. J. C., & Block, J. R. (1996). Prediction of Ground Vibration from Freight Trains. *Journal of Sound and Vibrations*, 193(1), 205–213.
- Kawprasert, A., & Barkan, C. P. L. (2010). Effect of train speed on risk analysis of transporting hazardous materials by rail. *Transportation Research Record: Journal of the Transportation Research Board* 2159, 59–68.
- Kawprasert, A. (2010). *Quantitative analysis of options to reduce risk of hazardous materials transportation by railroad* (Doctoral dissertation). Department of Civil and Environmental Engineering, University of Illinois at Urbana-Champaign, Urbana, IL.

- Krylov, V. V. & Ferguson, C. C. (1993). Calculations of Ground Vibrations from Heavy Freight Train. In *Proceedings of Institute of Acoustics*, 15, 59–68.
- Krylov, V. V. (1995). Generation of Ground Vibrations by Superfast Trains. *Applied Acoustics*, 44, 149–164.
- Krylov, V. V. (1996). Vibrational Impact of High-Speed Trains. I. Effect of Track Dynamics. *Journal of Acoustical Society of America*, 100(5), 3121–3134.
- Krylov, V. V. (1998). Effect of Track Properties on Ground Vibrations Generated by High-Speed Trains. *Acta Acustica–Acustica*, 84(1), 257–270.
- Krylov, V. V., Dawson, A. R., Heelis, M. E., & Collop, A. C. (2000) Rail Movement and Ground Waves Caused by High-Speed Trains Approaching Track-soil Critical Velocities. *IMechE Journal of Rail and Rapid Transit (Part F)*, 214(2), 107–116.
- Li, Y., Hu, P., Cai, C., Zhang, M., & Qiang, S. (2013). Wind Tunnel Study of a Sudden Change of Train Wind Loads Due to the Wind Shielding Effects of Bridge Towers and Passing Trains. *Journal of Engineering Mechanics*, 139(9), 1249–1259.
- Li, Y. L., Xiang, H. X., Zang, Y., & Qiang, S. Z. (2011). Coupling vibration of wind-vehicle-bridge system for the process of two trains passing each other. *China Civil Engineering Journal*, 44(12), 73–78 (in Chinese).
- Lin, C. Y., Saat, M. R., & Barkan, C. P. L. (2013). Causal Analysis of Passenger Train Accidents on Freight Rail Corridors. In *2013 World Congress on Railway Research*, Sydney, Australia.
- Lin, C. Y., & Saat, M. R. (2014). Semi-Quantitative Risk Assessment of Adjacent Track Accidents on Shared-Use Rail Corridor. In *Proceedings of the Joint Rail Conference*, Colorado Springs, CO.
- Liu, J., Li, R. X., & Zhao, J. (2009). Simulation Analysis of Aerodynamic Force for High-Speed Trains Passing at the Same Speed. *Rolling Stock*, 47(3), 5–9.
- Liu, X., Saat, M. R., & Barkan, C. P. L. (2010). Benefit-cost analysis of infrastructure improvement for derailment prevention. Joint Rail Conference, ASME, Urbana, IL.
- Liu, X., Barkan, C. P. L., & Saat, M. R. (2011). Analysis of Derailments by Accident Cause: Evaluating Railroad Track Upgrades to Reduce Transportation Risk. *Transportation Research Record: Journal of the Transportation Research Board*, 2261, 178–185.
- Liu, X., Saat, M. R., & Barkan, C. P. L. (2012). Analysis of causes of major train derailment and their effect on accident rates. *Transportation Research Record: Journal of the Transportation Research Board*, 2289, 154–163.

- Liu, X., Saat, M.R., & Barkan, C. P. L. (2013a). Safety effectiveness of integrated risk reduction strategies for rail transport of hazardous materials. *Transportation Research Record: Journal of the Transportation Research Board* 2374, 102–110.
- Liu, X., Saat, M. R., & Barkan, C. P. L. (2014a). Probability analysis of multiple-tank-car release incidents in railway hazardous materials transportation. *Journal of Hazardous Materials*, 276, 442-451.
- Liu, X., Lovett, A., Dick, C. T., Saat, M. R., & Barkan, C. P. L. (2014b). Optimization of Ultrasonic Rail Defect Inspection Frequency for the Improvement of Railway Transportation Safety and Efficiency. *Journal of Transportation Engineering*, 140(10), 1–10.
- Loumiet, J. R., & Jungbauer, W. G., (Eds.). (2005). *Train Accident Reconstruction and FELA & Railroad Litigation* (4<sup>th</sup> ed.). Tucson, AZ: Lawyers & Judges Publishing.
- Lovett, A. H., Barkan, C. P. L., & Dick, C.T. (2013). An Integrated Model for the Evaluation and Planning of Railroad Track Maintenance. In *Proceedings of the 2013 Annual Conference, American Railway Engineering and Maintenance of Way Association (AREMA)*, Indianapolis, IN.
- Madshus, C., & Kaynia, M., (2000). High-Speed Railway Lines on Soft Ground: Dynamic Behavior at Critical Speed. *Journal of Sound and Vibration*, 231(3), 689 – 701.
- Markos, S., & Pollard, J. (2013). [Passenger Train Emergency Systems: Review of Egress Variables and Egress Simulation Models](#). Technical Report DOT/FRA/ORD-13-22 Washington, DC: U.S. Department of Transportation, Federal Railroad Administration.
- Mei, Y. G., & Yu, N. Y. (1999). Boundary Conditions for Train Crossing Pressure Waves in a Tunnel. *Journal of Lanzhou Railway Institute*, 18(1), 61–65.
- Mei, Y. G., Yu, N. Y., Zhao, H. H., & Liu, Y. Q. (2002). Numerical Method on Transient Pressure with High Speed Trains Crossing Through a Tunnel. *Journal of the China Railway Society*, 24(2), 21–25.
- Morant, A., Wisten, A., Galar, D., Kumar, U., & Niska, S. (2012). Railway EMI Impact on Train Operation and Environment. In *Proceedings of the Electromagnetic Compatibility (EMC EUROPE) 2012 International Symposium*. Rome, Italy.
- Moyer, P. D., James, R. W., & Bechara, C. H. (1994). [Safety of High-Speed Guided Ground Transportation Systems: Intrusion Barrier Design Study](#). Technical Report DOT/FRA/ORD-95/04. Washington, DC: U.S. Department of Transportation, Federal Railroad Administration.
- Nash, A. (2003). Best Practice in Shared-Use High-Speed Rail Systems. San Jose, CA: San Jose State University, Mineta Transport Institute.

- National Transportation Safety Board. (1987). Safety Recommendation R-87-57. Washington, DC: National Transportation Safety Board.
- Nayak, P. R., Rosenfield, D. B., & Hagopian, J. H. (1983). Event Probabilities and Impact Zones for Hazardous Materials Accidents on Railroads. Technical Report DOT/FRA/ORD-83/20. Washington, DC: U.S. Department of Transportation, Federal Railroad Administration.
- Nelson, J. T., & Saurenman, H. J. (1983) [State of the Art Review – Prediction and Control of Groundborne Noise and Vibration from Rail Transit Trains](#). Technical Report UMTA-MA-06-0049-83-4. Washington, DC: U.S. Department of Transportation, Federal Railroad Administration.
- Nielsen, J., Berggren, E., Lolgen, T., Muller, R., Stallaert, B., & Pesqueux, L. (2013). Overview of Methods for Measurement of Track Irregularities Important for Ground-Borne Vibration. Publication RIVAS\_CHALMERS\_WP2\_D2\_5. Paris: International Union of Railways.
- Niska, S., & Ekman, J. (2004). EMC Problems in Railway Detector Systems. Nordic Rail, 12th Seminar on Nordic Railway Technique, Luleå, Sweden.
- Niska, S. (2008a). Measurements and Analysis of Electromagnetic Interferences in the Swedish Railway Systems (Doctoral dissertation). Luleå University of Technology, Luleå, Sweden.
- Niska, S. (2008b). Measurements and Analysis of Electromagnetic Interference in a Railway Signal Box—A Case Study. *International Journal of Reliability, Quality & Safety Engineering*, 18(3), 285–303.
- Niska, S. (2009). Electromagnetic Interference: A Major Source of Faults in Swedish Railway. *International Journal of Performability Engineering*, 5(2), 187–196.
- Oh, J., Washington, S. P., & Nam, D. (2006). “Accident prediction model for railway-highway interfaces.” *Accident Analysis & Prevention*, 38(2), 346–356.
- Peacock, R. D., & Braun, E. (1999). [Fire Safety of Passenger Trains Phase I: Material Evaluation \(Cone Calorimeter\)](#). Technical Report DOT/FRA/ORD-99/01. Washington, DC: U.S. Department of Transportation, Federal Railroad Administration.
- Peacock, R. D, Reneke, P. A., Averill, J. D., Bukowski, R. W., & Klote, J. H. (2002). [Fire Safety of Passenger Trains Phase II: Application of Fire Hazard Analysis Techniques](#). Technical Report DOT/FRA/ORD-01/16. Washington, DC: U.S. Department of Transportation, Federal Railroad Administration.
- Peacock, R. D, Averill, J. D., Madrzykowski, D., Stroup, Reneke, P. A., D. W., & Bukowski, R. W. (2004). Fire Safety of Passenger Trains Phase III: Evaluation of Fire Hazard Analysis Using Full-Scale Passenger Rail Car Tests. NISTIR 6563. Washington, DC: U.S. Department of Commerce, National Institute of Standards and Technology.

- Raghunathan, R. S. (2002). Aerodynamics of High-Speed Railway Train. *Progress in Aerospace Sciences*, 38(6–7), 469–514.
- Rail Safety and Standards Board. (2013). Railway Group Standard: Vehicle Safety, Fire, and Evacuation. Publication GM/RT2130. London: Rail Safety and Standards Board.
- Rulens, D. (2009). Typical Cross Sections for 15% Design. Publication TM 1.1.21. New York: Parsons Brinckerhoff
- Saat, M. R. (2009). *Optimizing railroad tank car safety design to reduce hazardous materials transportation risk*. (Doctoral dissertation). Department of Civil and Environmental Engineering, University of Illinois at Urbana-Champaign, Urbana, IL.
- Saat, M. R., & Barkan, C. P. L. (2011). Generalized railway tank car safety design optimization for hazardous materials transport: addressing the trade-off between transportation efficiency and safety. *Journal of Hazardous Materials*, 189, 62–68.
- Saat, M. R., & Barkan, C. P. L. (2013). Investigating Technical Challenges and Research Needs Related to Shared Corridors for High-Speed Passenger and Railroad Freight Operations. Technical Report DOT/FRA/ORD-13-29. Washington, DC: U.S. Department of Transportation, Federal Railroad Administration.
- Schafer, D. H., & Barkan, C. P. L. (2008). Relationship between train length and accident causes and rates. *Transportation Research Record: Journal of the Transportation Research Board*, 2043, 73–82.
- Sheng, X., Jones, C. J. C., & Thompson, D. J. (2004a). A Theoretical Study on the Influence of the Track on Train-induced Ground Vibration. *Journal of Sound and Vibration*, 272, 909–936.
- Sheng, X., Jones, C. J. C., & Thompson, D. J. (2004b). A Theoretical Model for Ground Vibration from Trains Generated by Vertical Track Irregularities. *Journal of Sound and Vibration*, 272, 937–965.
- Takemiya, H. (2003). Simulation of Track-ground Vibrations Due to A High-Speed Train: the Case of X-2000 at Ledsgard. *Journal of Sound and Vibration*, 261(3), 503–526.
- Tian, H. Q., & He, D. X. (2001). 3-D Numerical Calculation of the Air Pressure Pulse from Two Train Passing by Each Other. *Journal of the China Railway Society*, 23(3), 18–22.
- Treichel, T. T., Hughes, J. P., Barkan, C. P. L., Sims, R. D., Phillips, E. A., & Saat, M. R. (2006). Safety performance of tank cars in accidents: probability of lading loss. Publication RA-05-02. Washington, DC: American Association of Railroads, RSI-AAR railroad tank car safety research and test project.
- Ullman, K. B., & Bing, A. J. (1994). High Speed Passenger Trains in Freight Railroad Corridors: Operations and Safety Considerations. Technical Report DOT/FRA/ORD-95/05. Washington, DC: U.S. Department of Transportation, Federal Railroad Administration.

Union Pacific Railroad. (2011). Intermodal General Loading Guidelines. Omaha, NE: Union Pacific Railroad.

Wang, X. C. (2000). Study on Pressure Pulses on High-Speed Trains Passing Each Other. *Railway Locomotive and CAR*, 2000(4), 1–4.

## **Appendix A.**

# **Example International Railway Speed Incremental Project–China’s Experience**

---

### **1. Introduction**

Before the speed upgrade project, the average operating speed of passenger train in China was only about 30 mph in 1994. For freight trains, the average operating speed was about 19 mph. The railway transportation faced competition with highway and air transportation in the 1990s. The market share of railway had been decreasing. Therefore, to improve the competitiveness of railway transportation, China Railway undertook six major speed upgrades from 1999 to 2007 for both passenger and freight trains.

### **2. Six Major Upgrades**

#### *First Speed Upgrade*

In 1997, China Railway implemented the first major speed upgrade of three major intercity passenger lines: Beijing–Guangzhou, Beijing–Shanghai, and Beijing–Harbin. New passenger trains began with a maximum speed of 86 mph and the average speed of 55 mph. The number of non-stop express trains was increased as well. The overall average speed for passenger trains rose to 34 mph. On the freight side, a “five-fixed” freight train operation strategy was implemented, where freight trains started to have a fixed origin-departure, route, train number, schedule, and rate.

#### *Second Speed Upgrade*

In 1998, the maximum speed of trains on the Beijing–Guangzhou, Beijing–Shanghai, and Beijing–Harbin lines rose to 100 mph, increasing the average speed of the whole passenger train network in the country to 34 mph. New electrical multiple unit (EMU) tilting trains were placed into service. These trains ran at the maximum speed of 125 mph. The railroad became competitive against highway transportation and turned profitable in 1999.

#### *Third Speed Upgrade*

China implemented the third speed upgrade in 2000. Routes in western China were the main focus, including Lianyungang–Lanzhou, Lanzhou–Urumqi, Beijing–Kowloon, and Hangzhou–Zhuzhou. The vision of the "Four North-South and Two East-West Lines" railroad network was realized after the three speed upgrades. The national average passenger train speed reached 38 mph.

To accommodate higher operating speeds, the communication, signal system, and operation dispatching systems were also upgraded. On-board train control systems and the Dispatch Management Information System (DMIS) were developed. Due to the speed upgrades, safety standards were also enhanced. Automatic Train Stop (ATS), hot box detectors, and rail defect detectors were widely installed. Therefore, accidents regarding the violation of signal, broken axles or rail, or errant railroad vehicles decreased significantly.

#### *Fourth Speed Upgrade*

In 2001, China Railway implemented the fourth speed upgrade. A wide range of intercity lines between metropolitan areas across the country were improved (Beijing–Kowloon, Wuchang–Chengdu, the southern section of Beijing–Guangzhou, Hangzhou–Zhuzhou, Harbin–Dalian). The national average passenger train speed reached 39 mph.

#### *Fifth Speed Upgrade*

In 2004, China Railway implemented the fifth major speed upgrade. Areas around the capital of Beijing were the main focus, including Beijing–Guangzhou, Beijing–Shanghai and Beijing–Harbin. More express trains were added, and the travel time reduced significantly. For example, from Beijing to Shanghai, a 2-hour time reduction was achieved—from 14 hours to 12 hours. More trains operated at the maximum speed of 125 mph. The national average passenger train speed reached 41 mph. Express freight trains, with the maximum speed of 100 mph, were also introduced.

#### *Sixth Speed Upgrade*

In 2007, China Railway implemented the sixth major speed upgrade. Most higher speed trains were able to run on the upgraded lines to reach a maximum speed of between 125 mph and 156 mph. The speed upgrade encompassed 18 lines, including the Beijing–Harbin, Beijing–Shanghai, Beijing–Guangzhou and Lianyungang–Lanzhou lines. The national average passenger train speed reached 44 mph. Heavy freight trains (with 5,000 tonnes) on upgraded lines started to operate up to 75 mph.

The average speed of the national railroad network rose from about 30 mph to 44 mph. After the sixth speed upgrades, the length of existing railways with speeds of 75 mph and above was extended to 26,875 miles; 100-mph and above track was extended to 10,000 miles, and 125-mph track was extended to 4,011 miles. The Beijing–Harbin, Beijing–Guangzhou, Beijing–Shanghai, and Qingdao–Jinan lines reach a speed of 96 mph in some sections. After the sixth speed upgrades, China Railway stopped upgrading the existing lines and began constructing new dedicated lines for high-speed passenger trains to travel at 200 mph and above. Table A-1 summarizes the six speed upgrades.



**Table A-1 Summary for China Railway's Six Speed Upgrades**

No.	Date	Area	Cumulative length of track (in extended km, double track counted twice) that can carry high-speed trains with speed of:					Nat'l avg. passenger train speed (MPH)
			≥ 75 MPH	≥ 87.5 MPH	≥ 100 MPH	≥ 125 MPH	≥ 156 MPH	
Zero(Before)	1994							30.2
First	1997/4/1	Beijing-Guangzhou, Beijing-Shanghai, and Beijing-Harbin	874	837.5	470			34.3
Second	1998/10/1	Beijing-Guangzhou, Beijing-Shanghai, and Beijing-Harbin	4,031	2,201	690			34.5
Third	2000/10/21	Lianyungang-Lanzhou, Lanzhou-Urumqi, Beijing-Kowloon, Hangzhou-Zhuzhou	5,988	4,036	690			37.7
Fourth	2001/11/21	Beijing-Kowloon, Wuchang-Chengdu, The southern section of Beijing-Guangzhou, Hangzhou-Zhuzhou, Harbin-Dalian	8,229	6,112	690			39.1
Fifth	2004/4/18	Beijing-Guangzhou, Beijing-Shanghai, Beijing-Harbin	10,313		4,813	1,225		41.1
Sixth	2007/4/18	18 lines (Beijing-Harbin, Beijing-Shanghai, Beijing-Guangzhou, Lianyungang-Lanzhou, etc.)	26,875		10,000	4,011	528.8	43.9

### 3. Rail Shared Corridor Issues

New technologies and designs were developed to accommodate the higher train speeds discussed in the previous section. Most of the conventional railway network involves passenger and freight train operations on the same tracks. Detailed improvements in infrastructure, signals, communication, train control systems, and traction power are discussed in the following subsections.

#### *Alignment, Track, and Civil Works*

The following key enhancements related to Chinese rail infrastructure during the speed upgrades included:

1. Increased minimum radius of alignment
2. Reduced longitudinal slope or increased traction capacity of locomotives
3. Increased spacing of tracks
4. Increased self-weight of rails
5. Increased depth of ballast and width of ballast beds
6. Reduced the numbers of level-crossings
7. Added longitudinal dampers (Figure A-1) on bridges and reinforced their transversal stiffness



**Figure A-1 Longitudinal Damper on Bridges**

Other infrastructure enhancements included:

1. Reconstruction of Subgrades:  
When widening was needed for embankments, mortar rubble was adopted for corner walls if the widening width was less than 1.6 feet, while fill was adopted when the widening width was greater than 1.6 feet. If compactness of subgrade could not meet the requirements, replacement and fill measures were adopted.
2. Reconstruction of Bridges and Culverts:  
Measures such as fixing, strengthening, partial upgrading, and whole reconstruction were performed for dangerous and old bridges and culverts.
3. Reconstruction of Tunnels:  
Grounding and leak repairing, replacement of linings, strengthening side slopes, reconstructions of clearances, ballast beds, and overhead contact lines were performed.
4. Reconstruction of Stations:  
Some arrival-departure lines, passenger stations, flyovers, and subways were reconstructed and/or expanded.

### *Signaling and Train Control System*

China Railway successfully developed Chinese Train Control System 2 (CTCS2), a train control system with Chinese characteristics and original intellectual property rights. CTCS2 solved technical problems in operations such as high train density and mixed trains traveling at different speeds, electric multiple unit (EMU) cross-line running, and the interconnecting of system equipment.

CTCS2 (Figure A-2) consists of on-board equipment, a train control center, computer interlocking, centralized traffic control (CTC), a responder, and a track circuit. Train control information is transferred by track circuit with point type responder. Global System for Mobile Communications–Railway (GSM-R) is used in wireless communication.

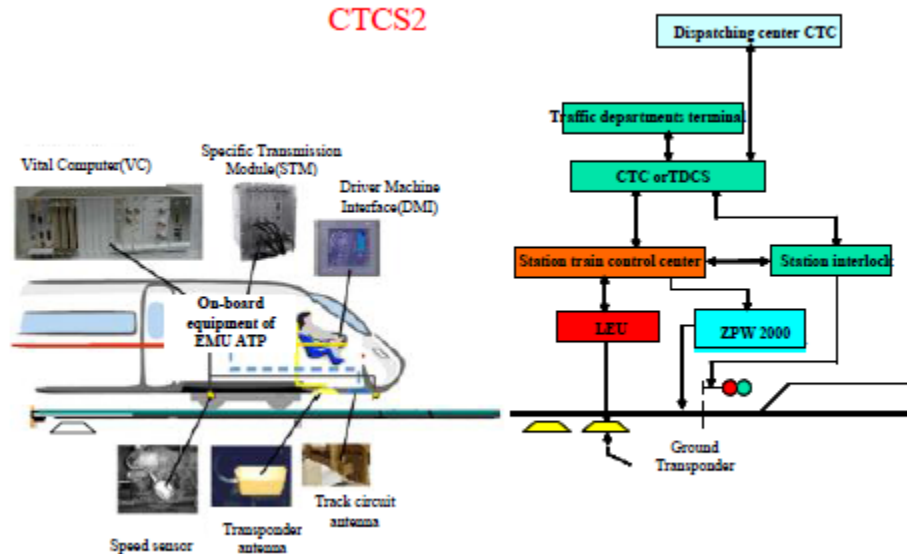


Figure A-2 CTSC2 System

### *Communication System*

GSM-R was adopted to provide an integrated mobile communication network and platform for reliable voice and data transmission for train dispatching, train control, security assurance, emergency rescue, maintenance, and train operation monitoring.

### *Traction Power Supply*

A traction power supply system for upgraded railway lines with a maximum speed of 124 mph was independently designed and established by China, which not only can accommodate the 124-mph multi-unit EMU but also the 75-mph freight trains running on the same tracks. Meanwhile, it can also fulfill the operation requirements for double-stack container trains.

### *High-Speed Electrical Multiple Unit*

China Railway mastered 9 key technologies for high-speed EMU assembly: train bodies, bogies, traction transformers, traction convertors, traction motors, traction control systems, train network control systems, braking systems—along with 10 main supporting technologies involving air conditioning systems, data collecting devices, train doors, train windows, seats, windshields, couplers and draft gear, current collecting devices, auxiliary power supply systems, and interior decoration materials. All these technologies supported the production of a subsequent series of trains for HSR operations.

### *Safety Information System*

All safety operation information from locomotives, vehicles, maintenance, electricity etc. were integrated at Railway Administrations for real-time comprehensive monitoring (Figure A-3).

Warning messages and contingency plans were implemented to identify and deal with equipment failures and operation security risks in a timely manner.

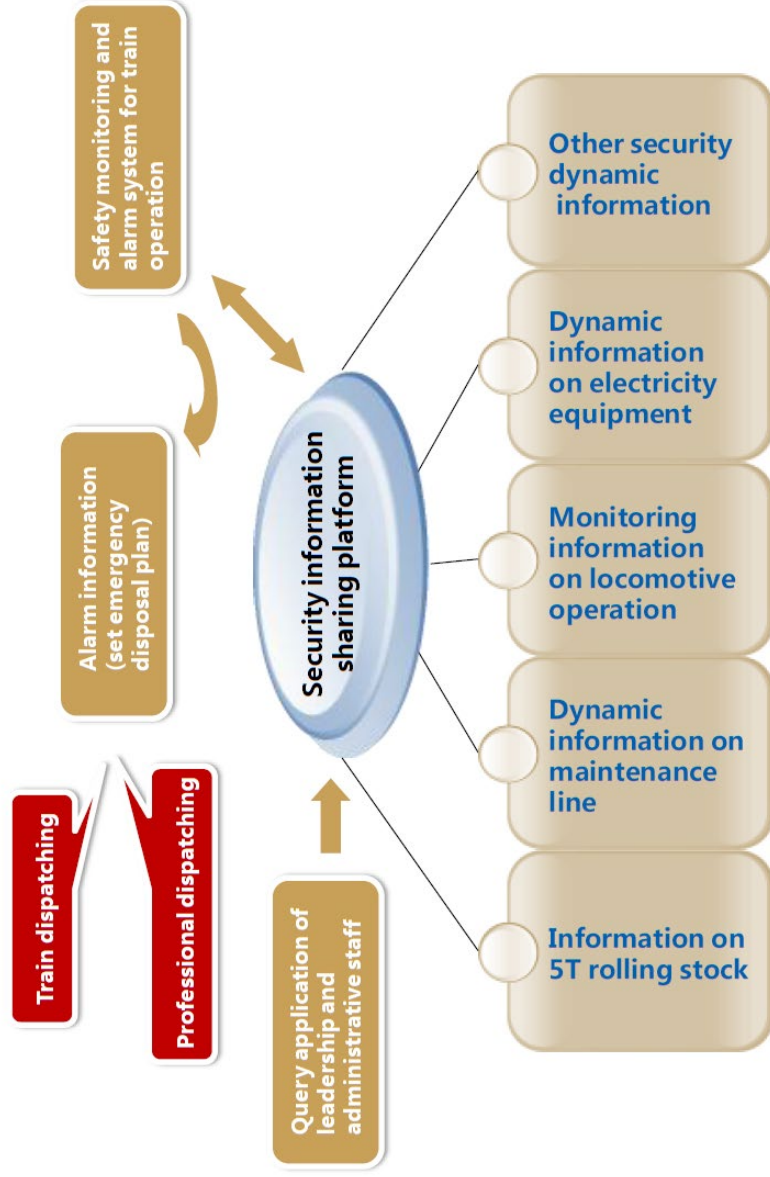


Figure A-3 Railway Safety Monitoring System

The safety monitoring system addresses the following hazards:

- Strong wind, rain, and snow and earthquake warnings
- Intrusion detection
- Railway line settlement monitoring
- Detection of catenary, communication, and signals
- Intelligent detection and diagnosis for train running quality, axle temperature, and fire protection
- Video monitoring along lines

*Acknowledgement: Key information for this appendix was gathered at a research exchange meeting at Beijing Jiaotong University (BJTU) hosted by Prof. He Shiwei and organized by Dr. Wang Haixing of the BJTU School of Traffic and Transportation.*

## Abbreviations and Acronyms

<b>Abbreviation or Acronym</b>	<b>Name</b>
ARHRAM	Adjacent Railroad Hazard Risk Assessment Model
AREMA	American Railway Engineering and Maintenance-of-Way Association
AAR	Association of American Railroads
ATS	Automatic Train Stop
CHSRA	California High-Speed Rail Authority
CTC	Centralized Traffic Control
CTCS2	Chinese Train Control System 2
CFD	Computational Fluid Dynamic
CPR	Conditional Probability of Release
CFAST	Consolidated Model of Fire and Smoke Transport
DOT	Department of Transportation
DMIS	Dispatch Management Information System
EMU	Electrical Multiple Unit
EMF	Electromagnetic Field
EMI	Electromagnetic Interference
EN	European Committee for Standardization
FMCSA	Federal Motor Carrier Safety Administration
FRA	Federal Railroad Administration
GSM-R	Global System for Mobile Communications – Railway
HRR	Heat Release Rates
HSGGT	High-Speed Guided Ground Transportation
HSR	High-Speed Rail
HST	High-Speed Train
IFS	Intrusion Factor Score
Maglev	Magnetic Levitation
MOW	Maintenance-of-Way
NIST	National Institute of Standards and Safety
NTSB	National Transportation Safety Board

<b>Abbreviation or Acronym</b>	<b>Name</b>
NCDOT	North Carolina Department of Transportation
NEC	Northeast Corridor
OCS	Overhead Catenary System
RSAC	Rail Safety Advisory Committee
RSSB	Rail Safety and Standards Board
RailTEC	Rail Transportation and Engineering Center
RHFA	Relative Hazard Frequency Assessment
ROW	Right-of-Way
RWP	Roadway Worker Protection
SSDF	Site-Specific Derailment Frequency
SUV	Sports Utility Vehicle
TCAD	Tank Car Accident Database
UI	University of Illinois at Urbana-Champaign
WVB	Wind Bridge Vehicle

---