



**NS 8898
(C40-9W - GE)
Locomotive Test Report**

CONTRACT NUMBER

FR-TEC-0003-11-01-00

This work was funded in whole or in part by the Federal Railroad Administration, US Department of Transportation under U.S. Government Grant FR-TEC-0003-11-01-00, and is therefore subject to the following license: The Government is granted for itself and others acting on its behalf a paid-up, nonexclusive, irrevocable worldwide license in this work to reproduce, prepare derivative works, distribute copies to the public, and perform publicly and display publicly, by or behalf of the Government. All other rights are reserved by the copyright owner.

By downloading, using, or referring to this document or any of the information contained herein you acknowledge and agree:

Ownership

This document and the information contained herein are the property of Meteorcomm LLC ("MCC"). Except for the limited rights granted under the above license, you obtain no rights in or to the document, its contents, or any related intellectual property all of which are the property of MCC.

Limited Use and Non Disclosure

This document is protected by copyright, trade secret, and other applicable laws.

Disclaimer of Warranty

This document and all information contained within this document or otherwise provided by MCC, and all intellectual property rights within, are provided on an "as is" basis. MCC makes no warranties of any kind and expressly disclaims all warranties, whether express, implied or statutory, including, but not limited to warranties of merchantability, fitness for a particular purpose, title, non-infringement, accuracy, completeness, interference with quiet enjoyment, system integration, or warranties arising from course of dealing, usage, or trade practice.

Assumption of Risk

You are responsible for conducting your own independent assessment of the information contained in this document (including without limitation schematic symbols, footprints and layer definitions) and for confirming its accuracy. You may not rely on the information contained herein and agree to validate all such information using your own technical experts. Accordingly, you agree to assume sole responsibility for your review, use of, or reliance on the information contained in this document. MCC assumes no responsibility for, and you unconditionally and irrevocably release and discharge MCC and its affiliates and their respective officers, directors, and employees ("MCC Parties") from any and all loss, claim, damage or other liability associated with or arising from your use of any of the information contained in this document.

Limitation of Liability & Disclaimer

This document is disseminated under the sponsorship of the Department of Transportation in the interest of information exchange. The United States Government assumes no liability for its contents or use thereof.

In no event shall MCC or the MCC parties be liable for any indirect, incidental, exemplary, special, punitive, or treble or consequential damages or losses, whether such liability is based on contract, warranty, tort (including negligence), product liability, or otherwise, regardless as to whether they have notice as to any such claims.

Any opinions, findings, conclusions, or recommendations expressed in this publication are those of the author(s) and do not necessarily reflect the view of the Federal Railroad Administration and/or U.S. DOT.

Trade or manufacturers' names any appear herein solely because they are considered essential to the objective of this report.

Hazardous Uses

None of the information contained in this document may be used in connection with the design, manufacture or use of any equipment or software intended for use in any fail safe applications or any other application where a failure may result in loss of human life or personal injury, property damage, or have a financial impact or in connection with any nuclear facility or activity or shipment or handling of any hazardous, ultra hazardous or similar materials ("Hazardous Uses"). MCC disclaims all liability of every kind for any Hazardous Uses, and you release MCC and the MCC Parties from and shall indemnify MCC and the MCC Parties against any such liability, including, but not limited to, any such liability arising from MCC's negligence.

Copyright and Trademark

Meteorcomm® and ITCnet® are registered trademarks of Meteorcomm LLC, and may not be used without express written permission of Meteorcomm LLC.

Trade or manufactures name may appear herein solely because they are considered essential to the objective of this report. The United States Government does not endorse products or manufacturers.

Document Number: 00002458-A

Table of Contents

Project Detail:	4
VSWR Test.....	10
TABLE A VSWR Plots.....	11
Insertion Loss	14
TABLE B Insertion Loss Plots	14
Antenna Isolation Test	16
TABLE C Antenna Isolation Plots	17
TABLE D Antenna Isolation Chart.....	20
Receive Intermodulation Test.....	24
Transmit Intermodulation Test.....	28
EMI Testing	36
BER Testing.....	51
TABLE E BER Test Results	52
Summary:	53

Project Detail:

Contract Number	FR-TEC-0003-11-01-00
Dates of Survey	March 26 th to 28 th , 2012
Locations	Norfolk Southern Shaffers Crossing Facility Roanoke VA 37.281941, N LAT -79.977658 W LON
Test Engineers	Derek Edmondson, Chris Goetz

The testing location for this locomotive was in Roanoke VA at the Shaffers Crossing locomotive shop. The locomotive was located on a siding near the entrance to the yard and was stationary throughout the testing period.



Shaffers Crossing locomotive shop
Figure 1

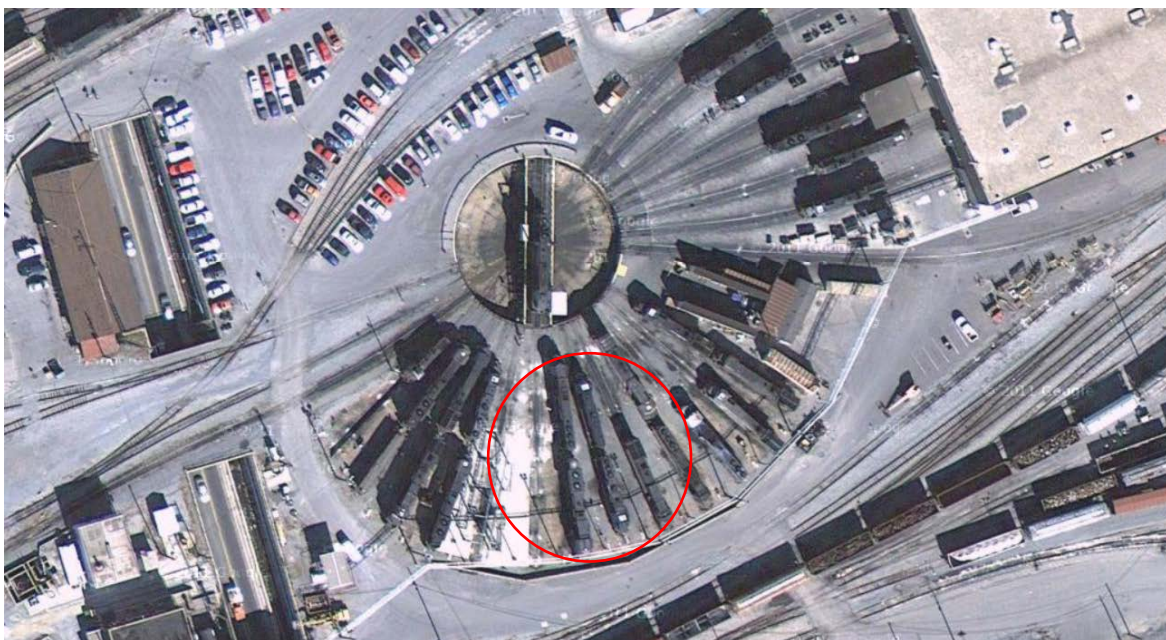

Shaffers Crossing locomotive shop
Figure 2



Locomotive under test NS 8898
GE Diesel Electric Locomotive Dash 9-40CW
Figure 3

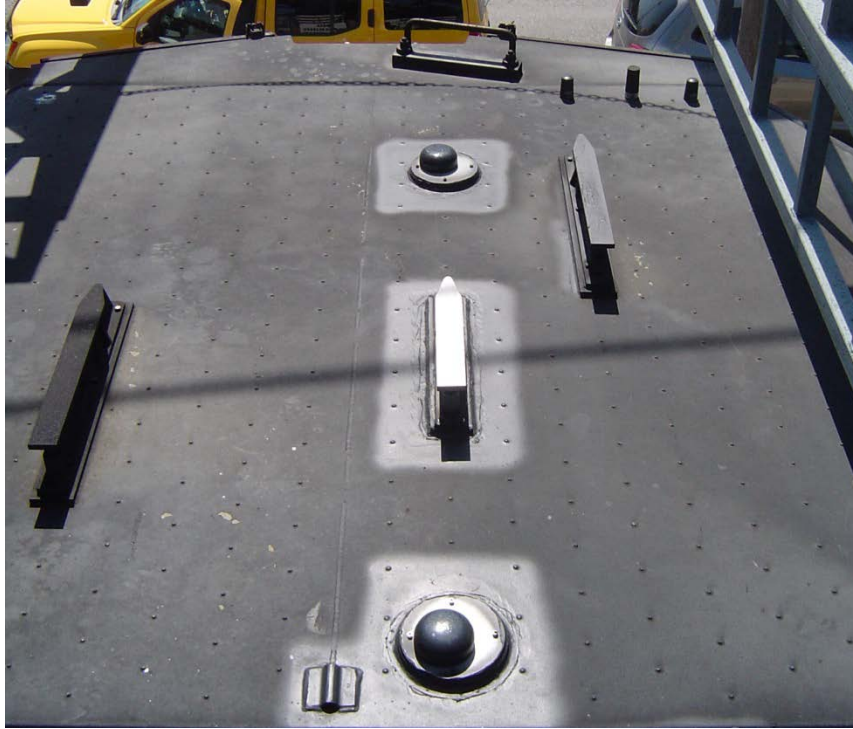

NS 8898 Rooftop View Front Facing



NS 8898 Rooftop View Rear Facing

The locomotive was outfitted with two Sinclair VHF antennas (only one in use), one PCTEL ASP-16 VHF Antenna (unused), one Sinclair PTC 220 antenna, 1UHF (HOT/EOT) antenna, three CEL 800 MHz antennas, and two GPS antennas (with integrated receivers).



Sinclair EXCAL221-8952446
Figure 4



Sinclair ST221-SF3SNF
Figure 5



LAIRD TA8903 Cellular
Figure 6



PCTEL MLPV 698 Cellular
(See summary section)
Figure 7



Sinclair ST321-SF3SUF
Figure 8



GARMIN GPS
Figure 9



PCTEL ASP-16 VHF Antenna
Figure 10

The radio systems included JEM VHF Voice, a Quantum UHF HOT/EOT system as well as the CTI OBN mobile data radio. The 220 PTC radio was not installed.



JEM VHF G17012-112 Voice Radio
Figure 11



HOT / EOT Quantum UHF Radio
Figure 12



CTI OBN
CTIREX2110MG2W2C
Figure 13

VSWR Test

This test is designed to collect VSWR data in several formats for use in locomotive noise and intermodulation reporting. The test involved collecting voltage standing wave ratio and return loss data in the following formats; VSWR, S1P scatter parameters, comma separated values, and a portable network graphics. It is important to know if the antenna system is properly matched to the transceiver equipment as this can be a source of intermodulation and/or standing waves in the RF system. The first set of data was collected at the RF port located closest to each antenna element in the locomotive radio frequency system to give an accurate picture of antenna matching. A second set of data recorded the VSWR at the end of the transmission line cable that connects to the radio transceiver antenna connector, including any installed filtering to show what the full system response is that is presented to the transceiver. This measurement includes all system losses.

This test helps us to characterize the band pass parameters of the antenna. The information is useful in determining how much the antenna element contributes to filtering out of band energy as well as whether or not the antenna is functioning correctly. The results from the VSWR testing indicated all antennas and associated components were functioning properly. The full data from this testing has been presented in Appendix A. Typical data recorded from the locomotive is presented in Table A below.

TABLE A VSWR Plots

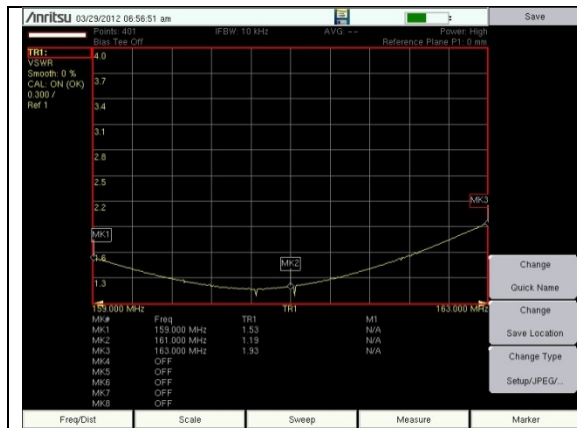

160 VHF ENG ANT



160 VHF ENG CBL



220 PTC ENG ANT

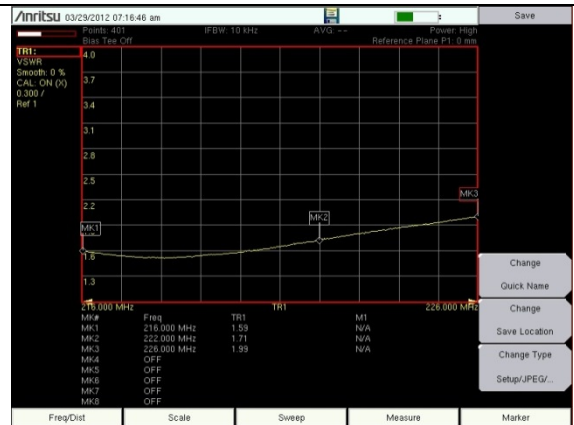

220 PTC ENG CBL

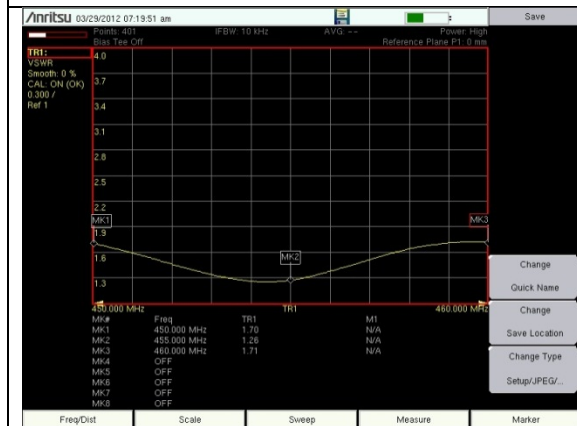

450 HOT



CEL1 ENG ANT

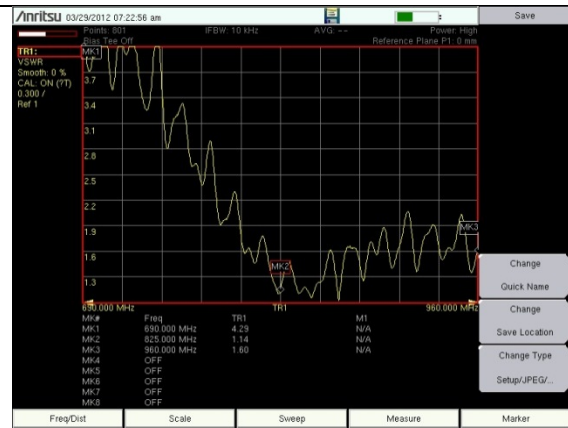

CEL1 ENG CBL



CEL2 CND ANT



CEL2 CND CBL

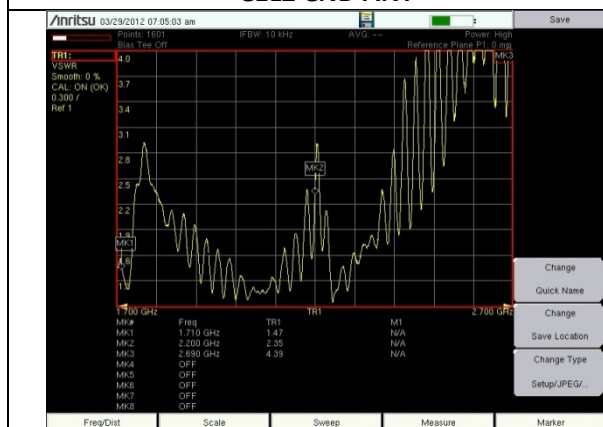

PCS1 ENG ANT

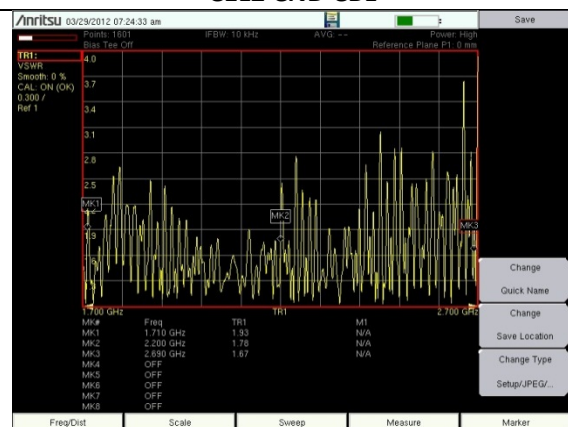

PCS1 ENG CBL

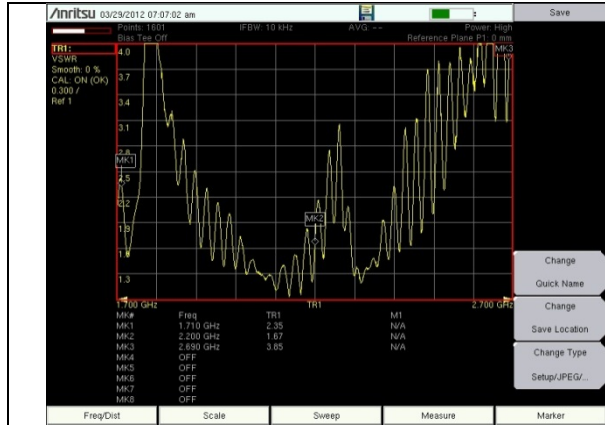

PCS2 CND ANT

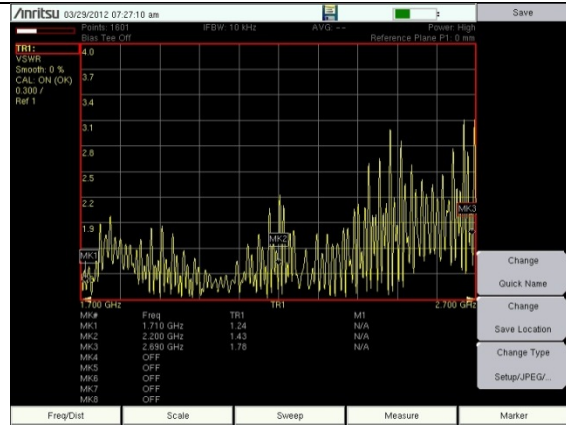

PCS2 CND CBL

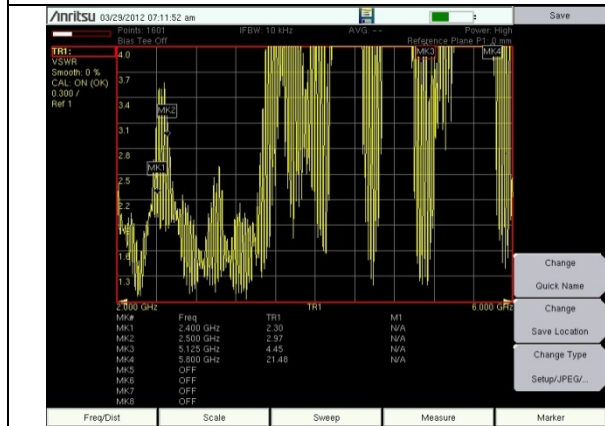

WIFI ENG ANT

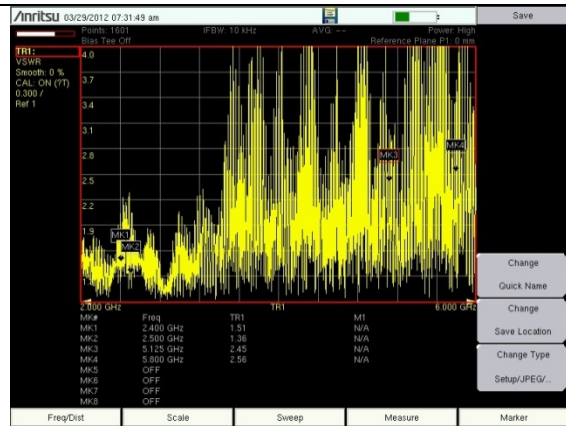

WIFI ENG CBL

Insertion Loss

This test is designed to collect insertion loss data in several formats for use in locomotive noise and intermodulation reporting. The test involved collecting insertion loss data in the following formats; insertion loss in dB, S1P scatter parameters, comma separated values, and a portable network graphics. It is important to know how much loss is experienced in the system in order to determine the impact on transmitted power and intermodulation effects. The test was performed on the transmission lines by measuring the loss from the antenna connection port to the equipment port. The test is frequency specific and each cable was measured based on the appropriate frequency range.

This report is useful for evaluating cable integrity and is representative of any losses that are present in the system. At the completion of this testing it was found that all on-board elements were in compliance as compared to planned values. A full report has been included in Appendix B.

TABLE B Insertion Loss Plots



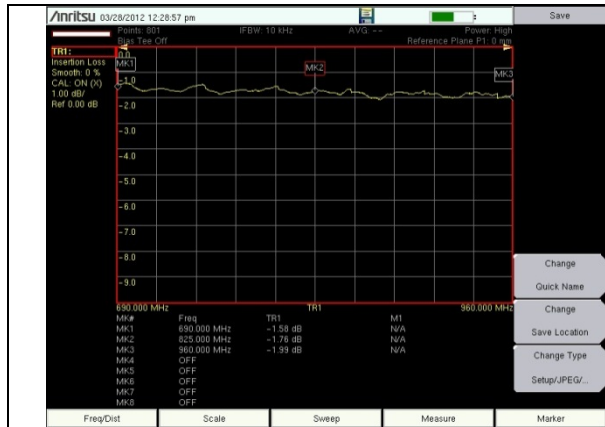

CEL1 ENG

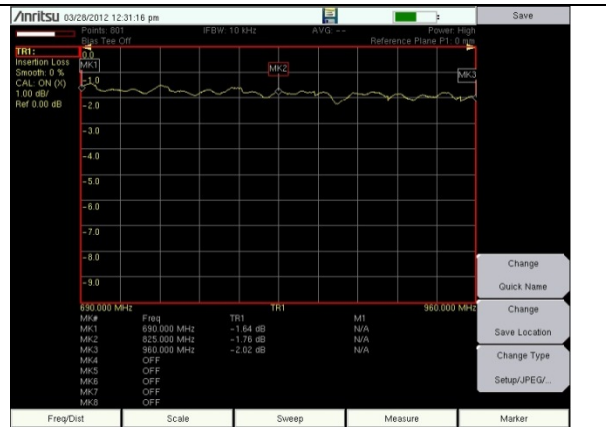

CEL2 CND

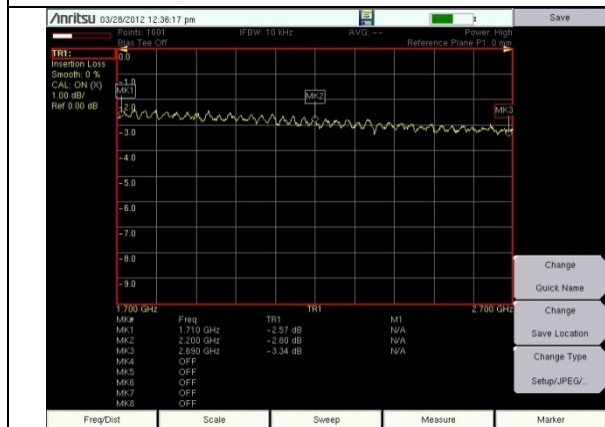

PCS1 ENG

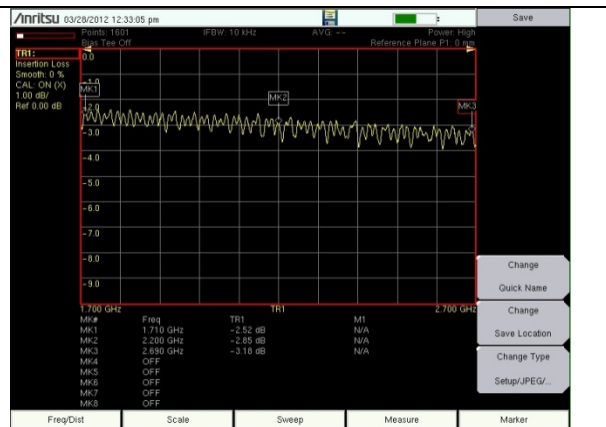

PCS2 CND

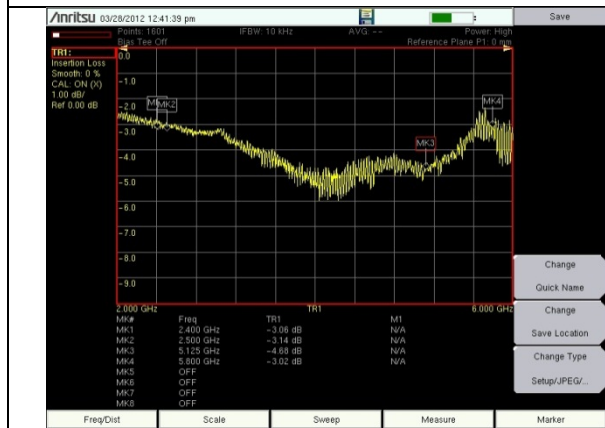

WIFI ENG

Antenna Isolation Test

This test is designed to collect information on the amount of free space isolation between each antenna and each other antenna. This value in decibels and is used to calculate the amount of power from each radio impacting each other radio receiver front end during transmission. High signal levels impacting the receiver front end of a radio in receive mode will cause intermodulation products in proportion to the power received from the transmitting radio. The antenna isolation data is also used to determine the need for filtering in the system.

This test is frequency specific, each radio transmits at a certain level in the frequency it is configured to transmit, and the power of this transmitted signal is measured at each other radio antenna. The test was performed by measuring the loss from the transmitting radio antenna to each other antenna, and the data was recorded in decibel format. The information gathered from this test correlates to the amount on intermodulation that is present in the roof environment, and possible prevention methods.

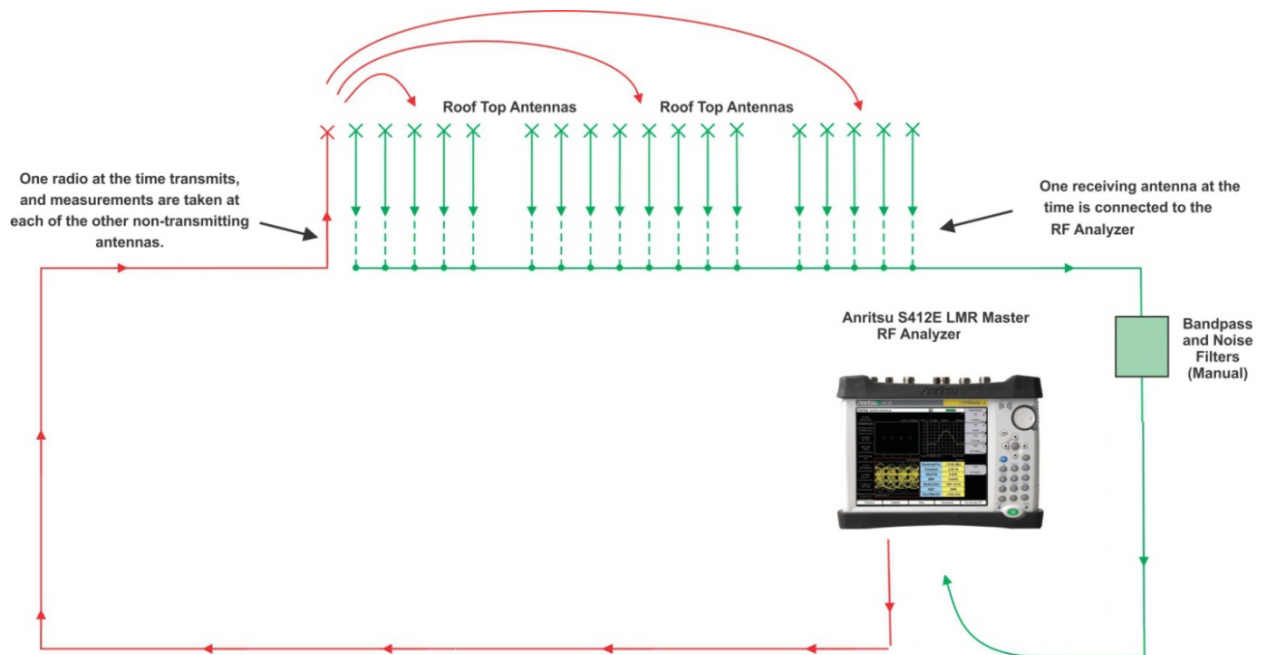

Antenna Isolation Testing Configuration
Figure 14

TABLE C Antenna Isolation Plots

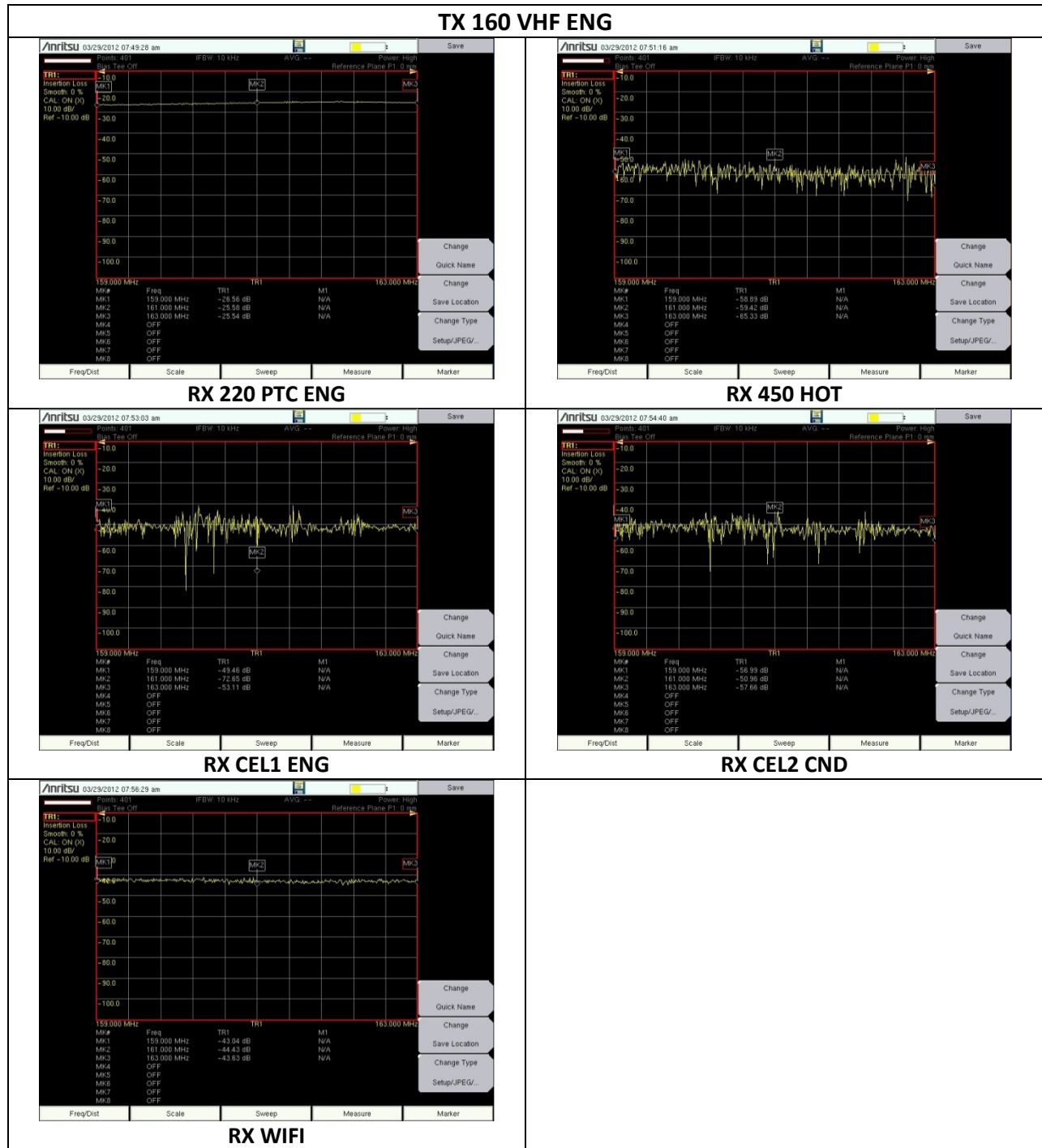

TX 220 PTC ENG

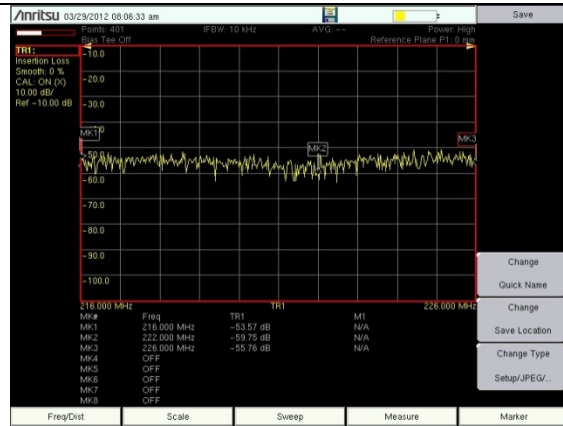
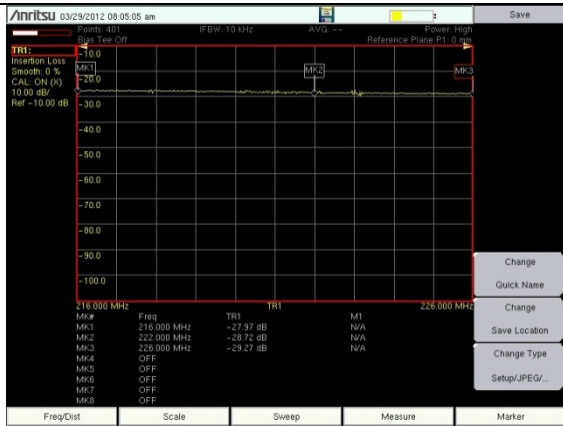

RX 160 VHF

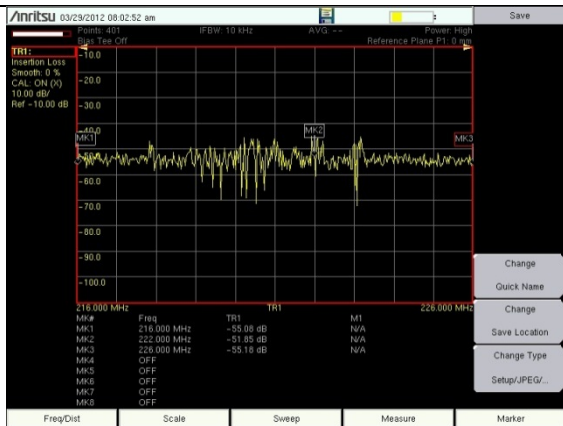

RX 450 HOT

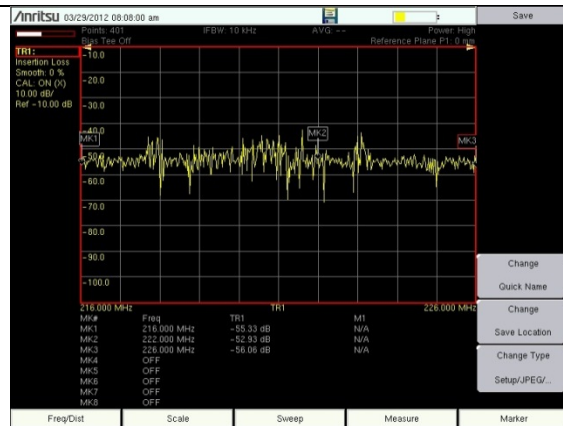

RX CEL1 ENG

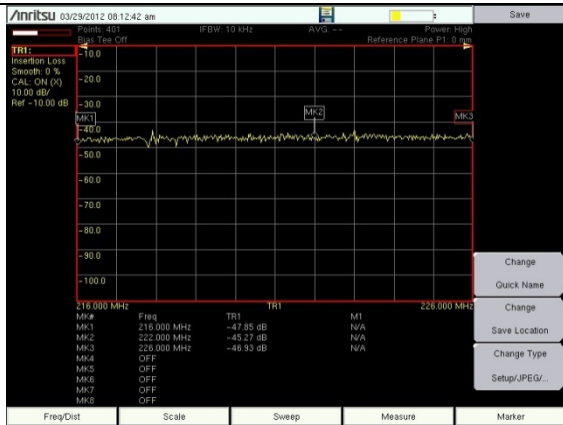

RX CEL2 CND

RX WIFI

TX 450 HOT

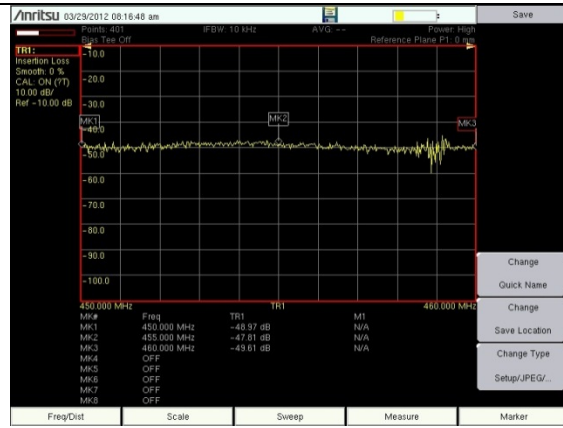
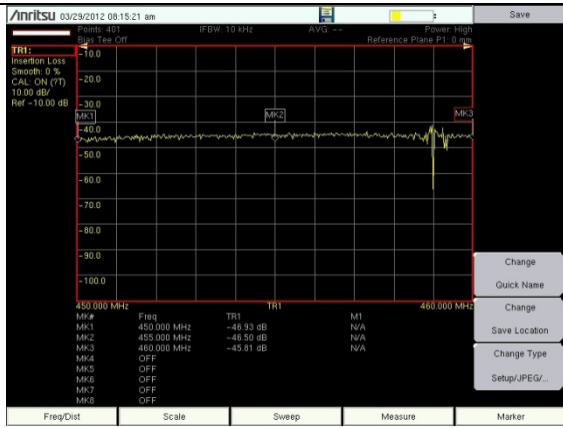

RX 160 VHF

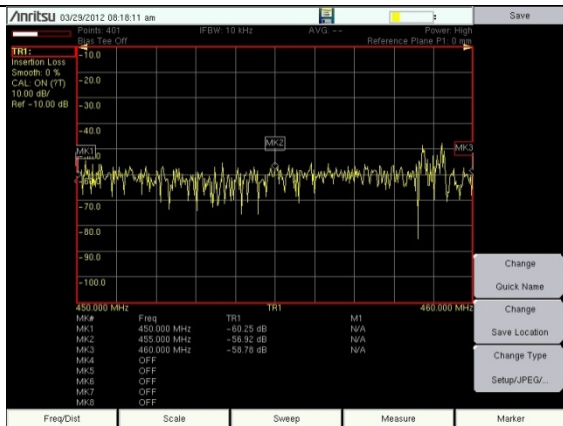

RX 220 PTC ENG

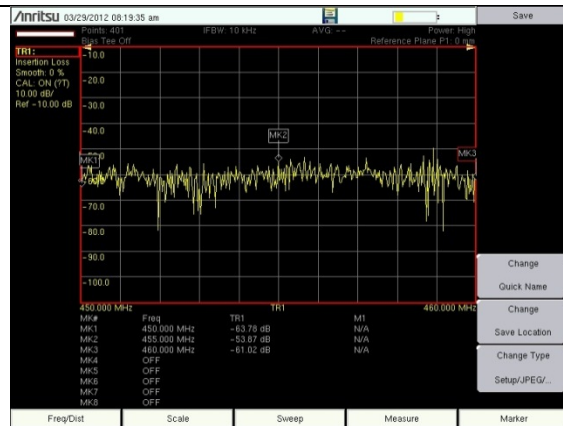

RX CEL1 ENG

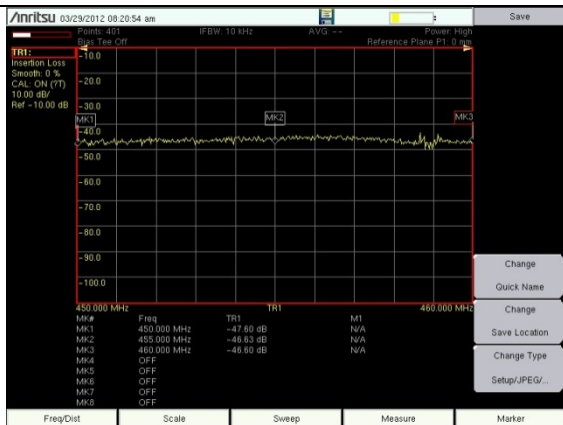

RX CEL2 CND

RX WIFI

TABLE D Antenna Isolation Chart

Receive Band	VHF 161	220 ENG	220 CON NEQ	HOT 450 CBL	DPA 450 NEQ	DPB 450 NEQ	ENG CEL 1 ENG	ENG CEL 2 CND	ENG WIFI 1 ENG	CON CEL 2 NEQ	CON CEL 4 NEQ	CON WIFI 2 NEQ
Transmit Band	(dBm)	(dBm)	(dBm)	(dBm)	(dBm)	(dBm)	(dBm)	(dBm)	(dBm)	(dBm)	(dBm)	(dBm)
VHF 161	TB	-25.8	NEQ	-60.1	NEQ	NEQ	-52.1	-52.0	-43.0	NEQ	NEQ	NEQ
220 ENG	-28.3	TB	NEQ	-57.1	NEQ	NEQ	-50.1	-50.3	-45.7	NEQ	NEQ	NEQ
220 CON	NEQ	NEQ	NEQ	NEQ	NEQ	NEQ	NEQ	NEQ	NEQ	NEQ	NEQ	NEQ
HOT 450 CBL	-45.3	-48.6	NEQ	TB	NEQ	NEQ	NF	-59.6	-46.3	NEQ	NEQ	NEQ
DPA (NEQ)	NEQ	NEQ	NEQ	NEQ	NEQ	NEQ	NEQ	NEQ	NEQ	NEQ	NEQ	NEQ
DPB (NEQ)	NEQ	NEQ	NEQ	NEQ	NEQ	NEQ	NEQ	NEQ	NEQ	NEQ	NEQ	NEQ
Receive Band	VHF 161 Filter	220 ENG Filter	220 CON Filter	HOT 450 Filter	DPA 450	DPB 450	ENG CEL 1 GRAY	ENG CEL 3 BLUE	ENG WIFI 2 GRN	CON CEL 2 ORG	CON CEL 4 GRN	CON WIFI 1 BLK
Transmit Band	(dBm)	(dBm)	(dBm)	(dBm)	(dBm)	(dBm)	(dBm)	(dBm)	(dBm)	(dBm)	(dBm)	(dBm)
VHF 161 Filter	NEQ	NEQ	NEQ	NEQ	NEQ	NEQ	NEQ	NEQ	NEQ	NEQ	NEQ	NEQ
220 ENG Filter	NEQ	NEQ	NEQ	NEQ	NEQ	NEQ	NEQ	NEQ	NEQ	NEQ	NEQ	NEQ
220 CON Filter	NEQ	NEQ	NEQ	NEQ	NEQ	NEQ	NEQ	NEQ	NEQ	NEQ	NEQ	NEQ
HOT 450 Filter	NEQ	NEQ	NEQ	NEQ	NEQ	NEQ	NEQ	NEQ	NEQ	NEQ	NEQ	NEQ
DPA (NEQ)	NEQ	NEQ	NEQ	NEQ	NEQ	NEQ	NEQ	NEQ	NEQ	NEQ	NEQ	NEQ
DPB (NEQ)	NEQ	NEQ	NEQ	NEQ	NEQ	NEQ	NEQ	NEQ	NEQ	NEQ	NEQ	NEQ

Antenna Isolation Table

The data recorded from the locomotive included both non-filtered and filtered information if the locomotive was equipped, or if future versions were to be equipped with band specific filters.

Note --NS has not yet defined a filter plan. Additionally, the Locomotive Antenna layout configuration shown is not the final evolution for PTC implementation. Therefore, filters were not tested. However, the information is still useful, as other Railroads may consider a similar approach as outlined.

In the paired figures below, the “A” drawing shows the isolation data with no filtering and was mapped to show the relationship between antenna spacing and free space path loss. There are other factors to be considered such as the antenna element type and frequency response which will contribute to out of band rejection characteristics. In the cases where there is diversity or redundant antennas spaced across the locomotive, notice how the symmetry in the isolation numbers which tracks with the layout of the antenna elements. The “C” diagrams indicate what energy is seen by the primary element from different frequency bands non-filtered. The results here will correlate to the intermodulation data collected in later testing.

Note that measurements designated “<-60 dB” are actually below the noise floor of the instrument.

NS 8898 Antenna Isolation
VHF Mapping

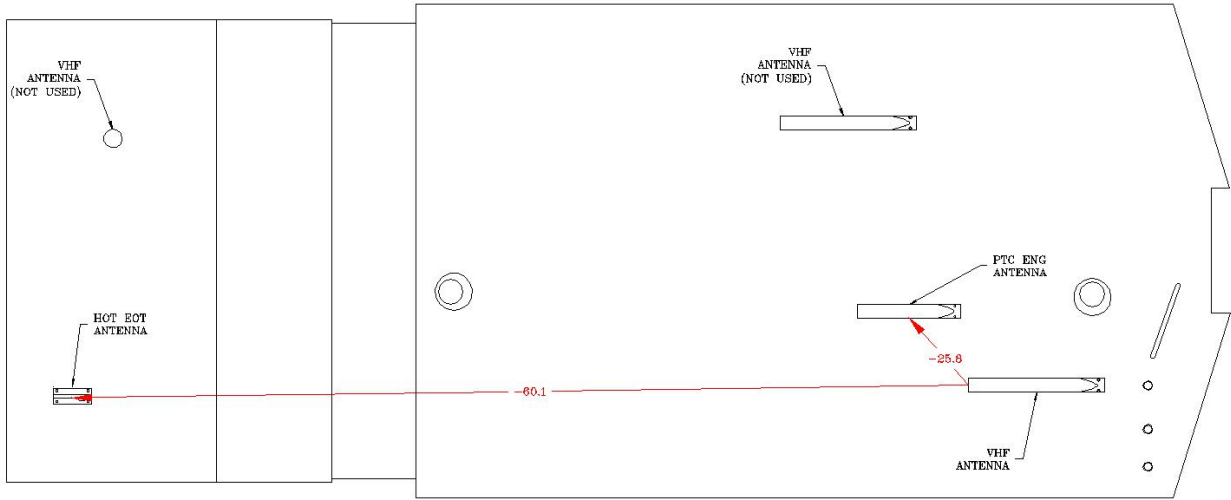

Figure 15 A
XMIT

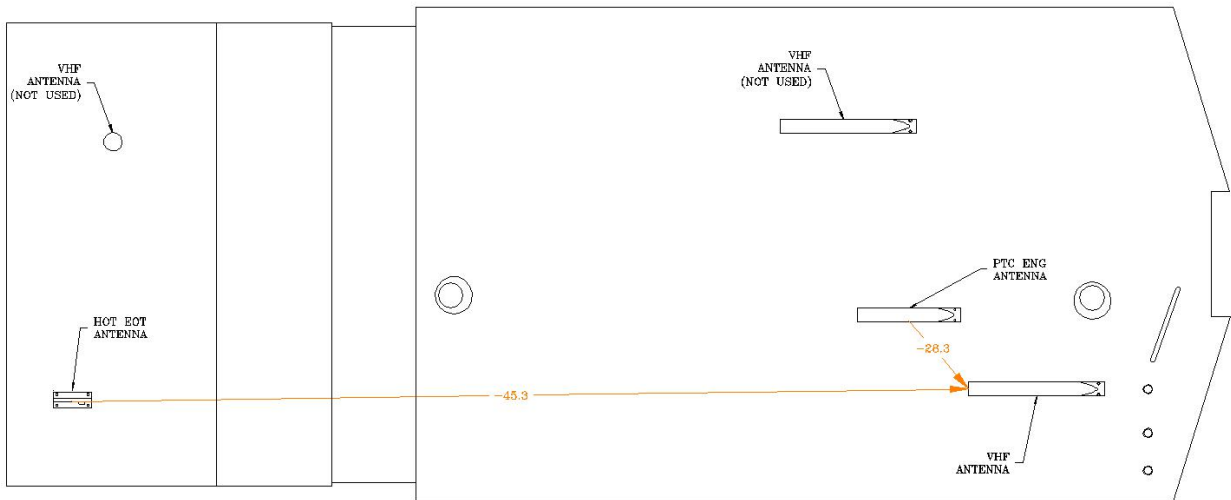

Figure 15 B
RCV

NS 8898 Antenna Isolation
PTC ENG Mapping

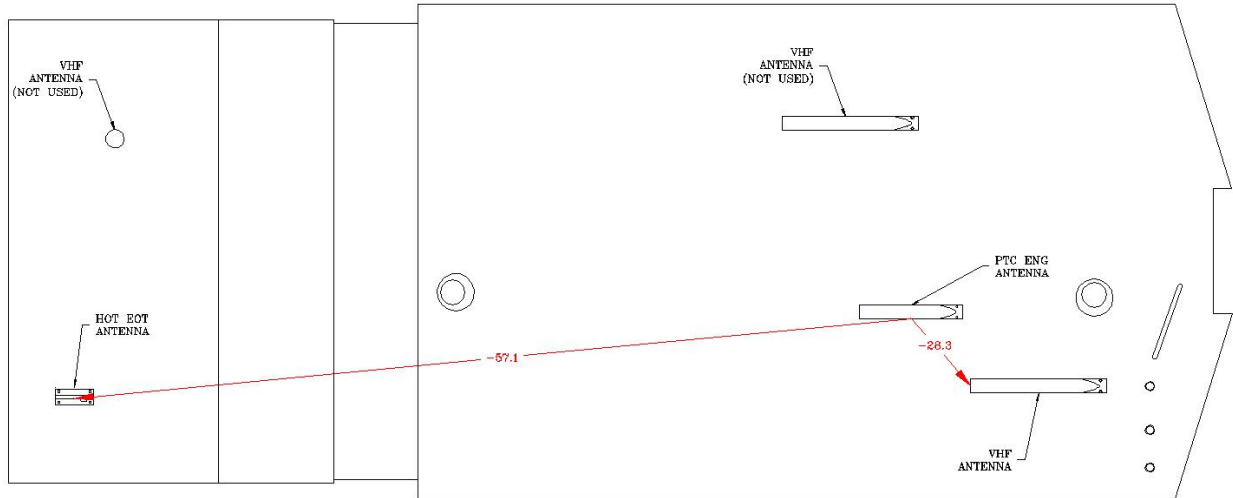

Figure 16 A
XMIT

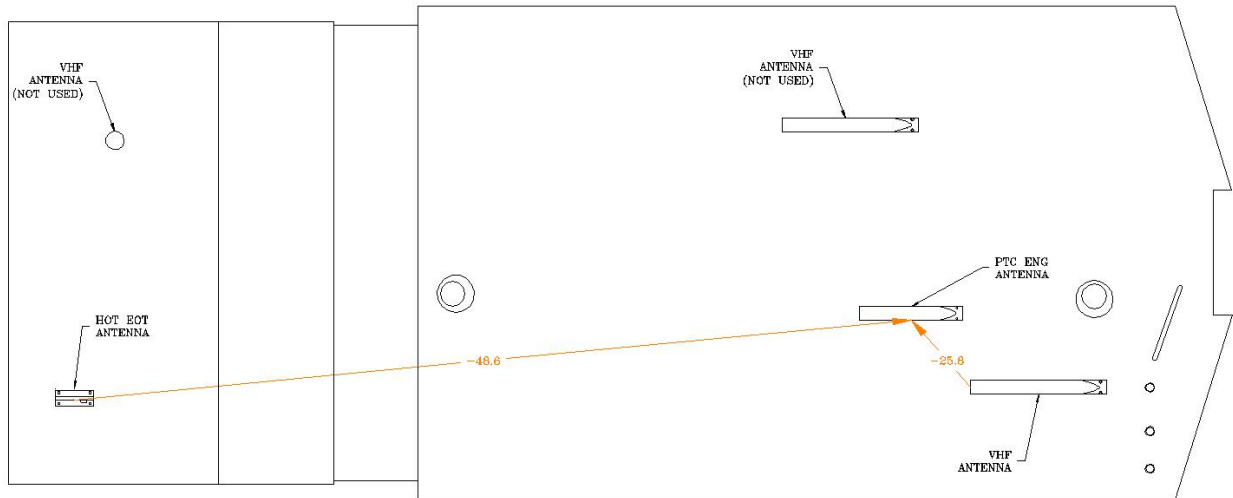

Figure 16 B
RCV

NS 8898 Antenna Isolation HOT Mapping

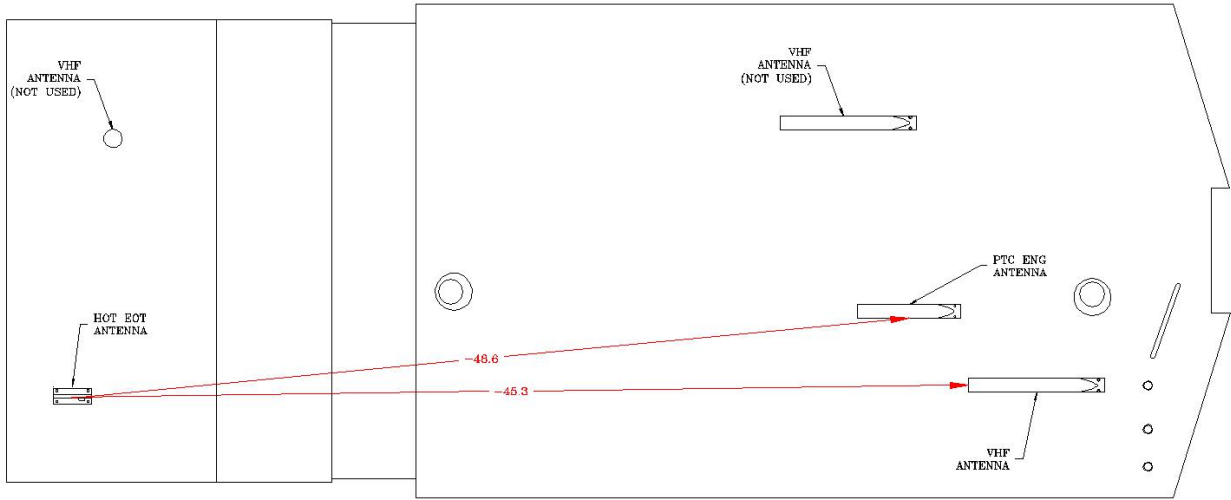

Figure 17 A
Non-Filtered

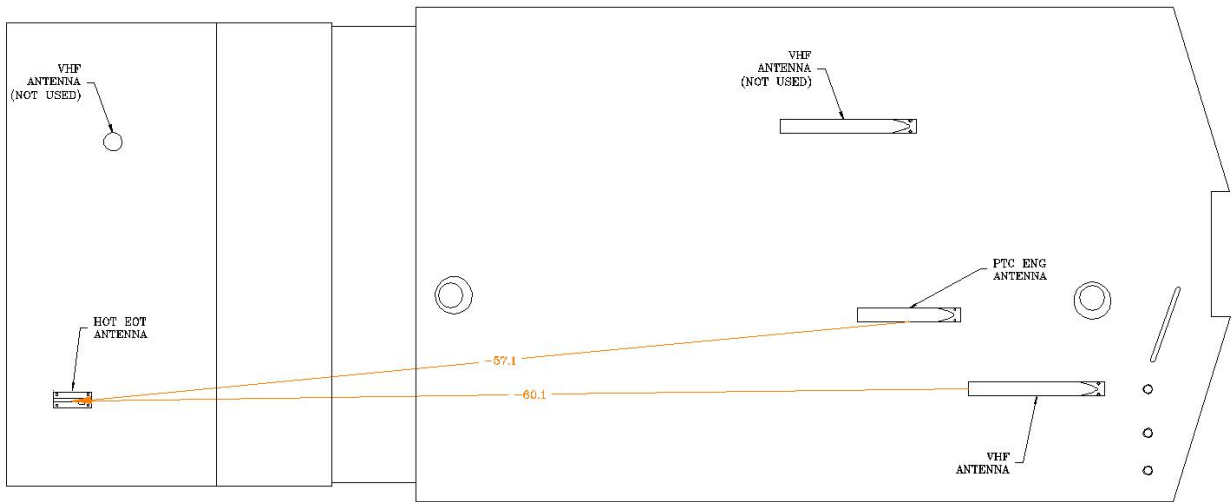

Figure 17 B
RCV

Receive Intermodulation Test

This test provides information on intermodulation products generated at the front end of each radio receiver when it is impacted by high power signals from the transmitting radio.

Each of the on board radios transmits at nominal power, and using a dual directional coupler the radio under test is measured for the amount of intermodulation products generated at the front end of the radio receiver and re-radiated back through the same antenna. Note that the radio under test is not transmitting.

A Dual Directional Coupler rated for a maximum power handling of 500 Watts was used to separately measure signals coming from the antenna to the radio receiver front end, and from the receiver front end travelling to the antenna and being transmitted as intermodulation products.

This Dual Directional Coupler has six ports, one for Antenna, one for Radio, two for 50 ohms loads, one to measure signals coming from the antenna to the radio transceiver, and one port to measure signals from the radio transceiver to the antenna.

In the IMD Test Apparatus diagram, the initial radio under test shown is the AAR Voice Radio, operating at ~ 160 MHz. Its Receiver is coupled directly to its existing transmission path, including Antenna (and Filter, if equipped or planned). The RF Sensor is coupled 20 dB down to the Receiver in the Radio under Test. The other radios of interest on the Locomotive (DPA, DPB, and HOT/EOT) are then keyed and RF energy from those radios pass through their respective existing transmission paths, including Antennas (and Filters, if equipped or planned). The RF energy then propagates into the Antenna of the Radio under Test, and then into the Receiver under test. Any IMD products in the 220 MHz spectrum generated in the Receiver that would be propagated via the Antenna system are measured by the RF Sensor.

A permutation of the IMD Test Apparatus is configured for each of the other radios of interest (DPA, DPB, and HOT/EOT), so that each of them is connected as a Radio under Test, and the process is repeated.

This particular locomotive was only equipped with an HOT/EOT radio and antenna, and not equipped with Distributed Power Radios or Antennas. Therefore the only systems evaluated were the VHF and the HOT/EOT. Note that without Distributed Power Radios, the issues seen in other tests involving both brands of HOT/EOT are not seen here (See BNSF 5018, CSX 985).

Note that the spur at 224.000 MHz appears to be an artifact of the RF Sensor, and should be ignored.

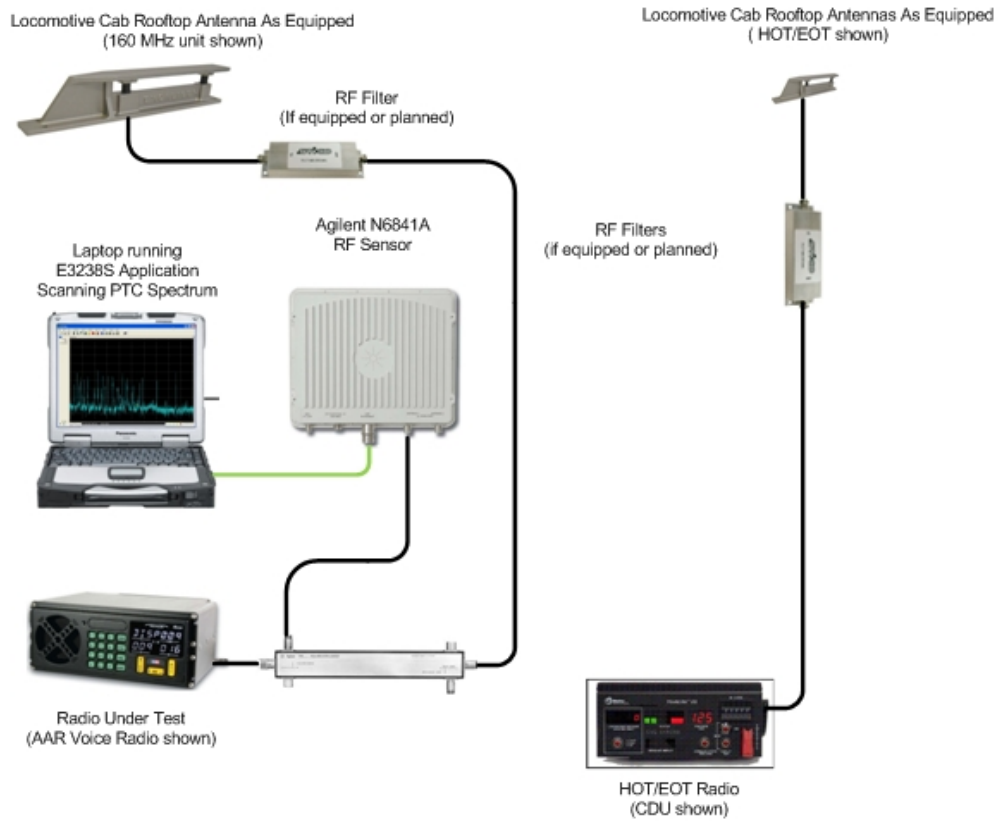

Receive Intermodulation Testing Configuration
Figure 18

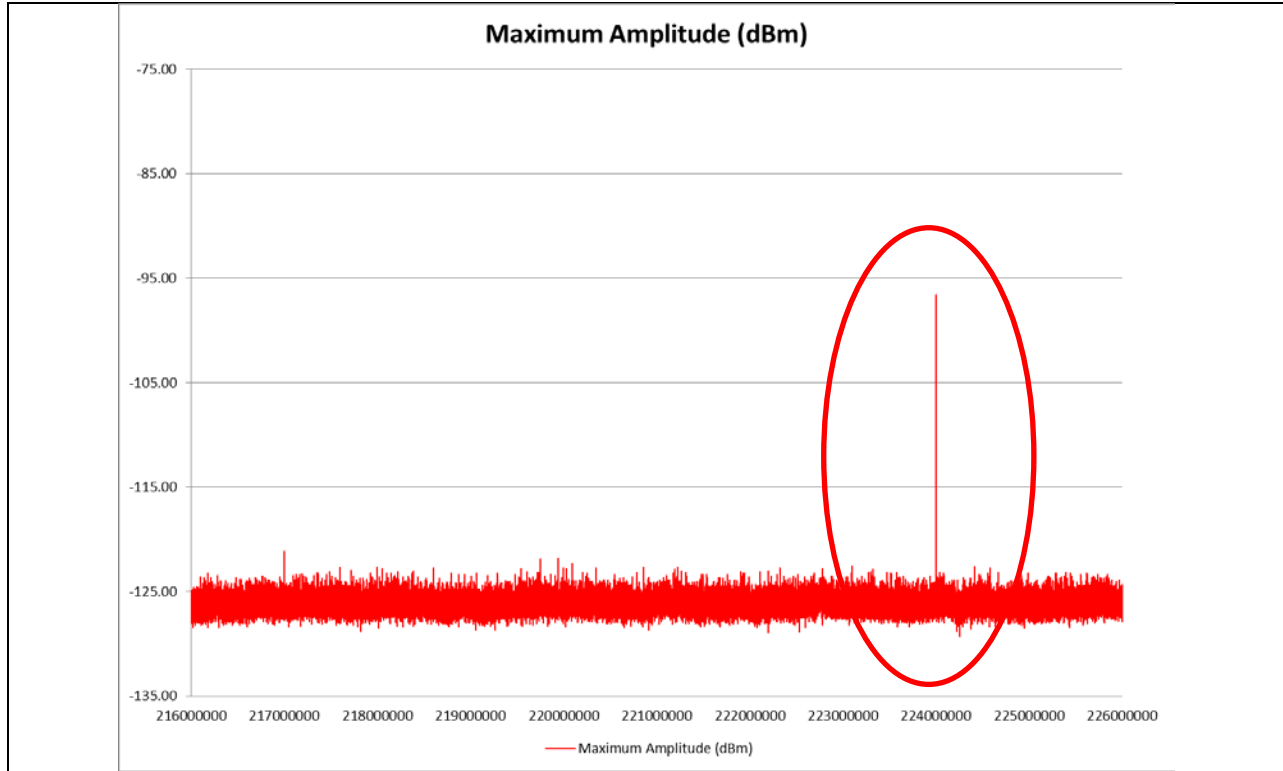

VHF RX with HOT/EOT TX

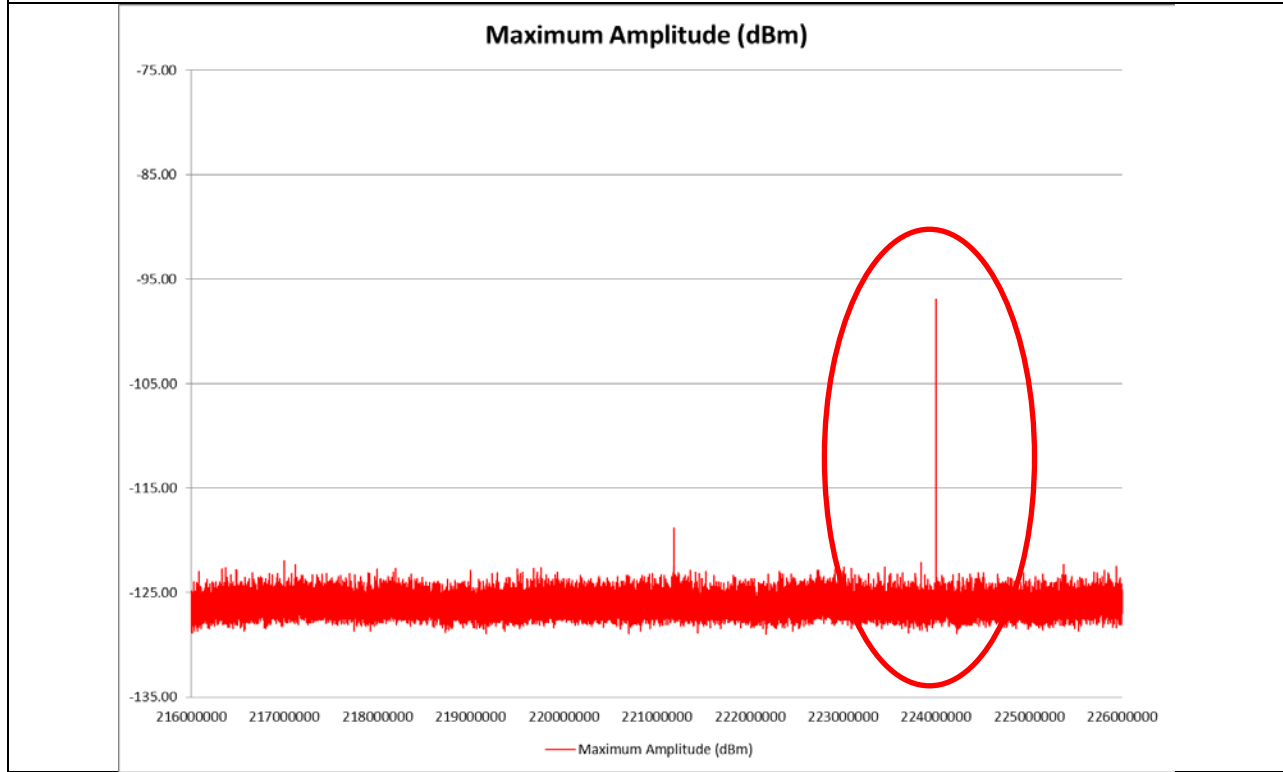

HOT/EOT RX with VHF TX

Notes:

The energy detection at 224 MHz (highlighted with red circle) was present throughout our testing and is considered to be an artifact of the RF Sensor, and should be ignored. Note the small spur generated near 221 MHz in the HOT/EOT Receiver.

Transmit Intermodulation Test

This test provides information on intermodulation products produced by multiple radio transmissions at the same time. Several radios on a locomotive, such as Voice 161 MHz, PTC 220 MHz, DP A UHF or DP B UHF, HOT UHF and SPEC 200 900 MHz, may transmit simultaneously. These simultaneous transmissions may occur on two, three or more radios at the same time.

Two, three, four or more on-board radios combined in different groups transmit simultaneously. Each of the radios transmits at nominal power, and using a dual directional coupler each other non-transmitting radio is measured for the amount of signals received from the transmitting radios entering through the antenna, and for the amount of intermodulation products generated at the front end of the radio receiver and transmitted back through the same antenna.

A Dual Directional Coupler rated for a maximum power handling of 500 Watts is used to separately measure signals coming from the antenna to the radio receiver front end, and from the receiver front end travelling to the antenna and being transmitted as intermodulation products.

This Dual Directional Coupler has six ports, one for Antenna, one for Radio, two for 50 ohms loads, one to measure signals coming from the antenna to the radio transceiver, and one port to measure signals from the radio transceiver to the antenna.

In the IMD Test Apparatus diagram, the initial radio under test shown is the AAR Voice Radio, operating at ~ 160 MHz. Its Transmitter is coupled directly to its existing transmission path, including Antenna (and Filter, if equipped or planned). The RF Sensor is coupled 20 dB down (or more, as needed to protect the RF Sensor) to the Transmitter in the Radio under Test. The other radios of interest on the Locomotive (DPA, DPB, and HOT/EOT) are then keyed and RF energy from those radios pass through their respective existing transmission paths, including Antennas (and Filters, if equipped or planned). The RF energy then propagates into the Antenna of the Radio under Test, and then into the Transmitter under test. Any IMD products in the 220 MHz spectrum generated in the Transmitter that would be propagated via the Antenna system are measured by the RF Sensor.

A permutation of the IMD Test Apparatus is configured for each of the other radios of interest (DPA, DPB, and HOT/EOT), so that each of them is connected as a Radio under Test, and the process is repeated.

This particular locomotive was only equipped with an HOT/EOT radio and antenna, and not equipped with Distributed Power Radios or Antennas. Therefore the only systems evaluated were the VHF and the HOT/EOT. Note that without Distributed Power Radios, the issues seen in other tests involving both brands of HOT/EOT are not seen here (See BNSF 5018, CSX 985).

Note that the spur at 224.000 MHz appears to be an artifact of the RF Sensor, and should be ignored.

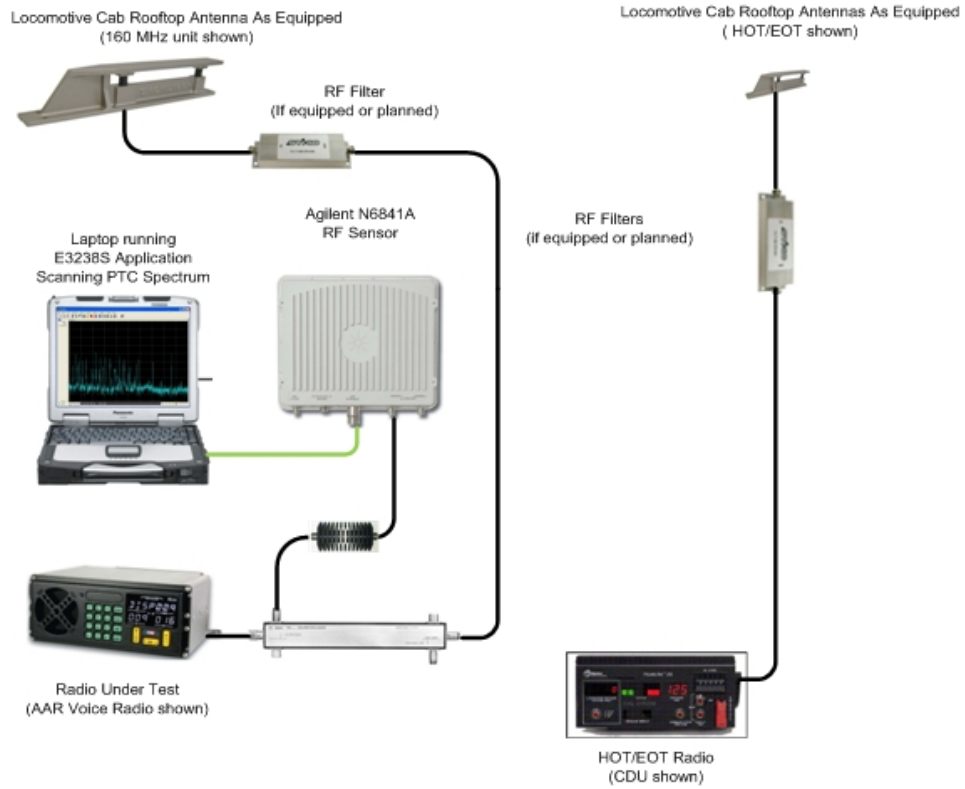

Transmit Intermodulation Testing Configuration
Figure 19

VHF XMIT

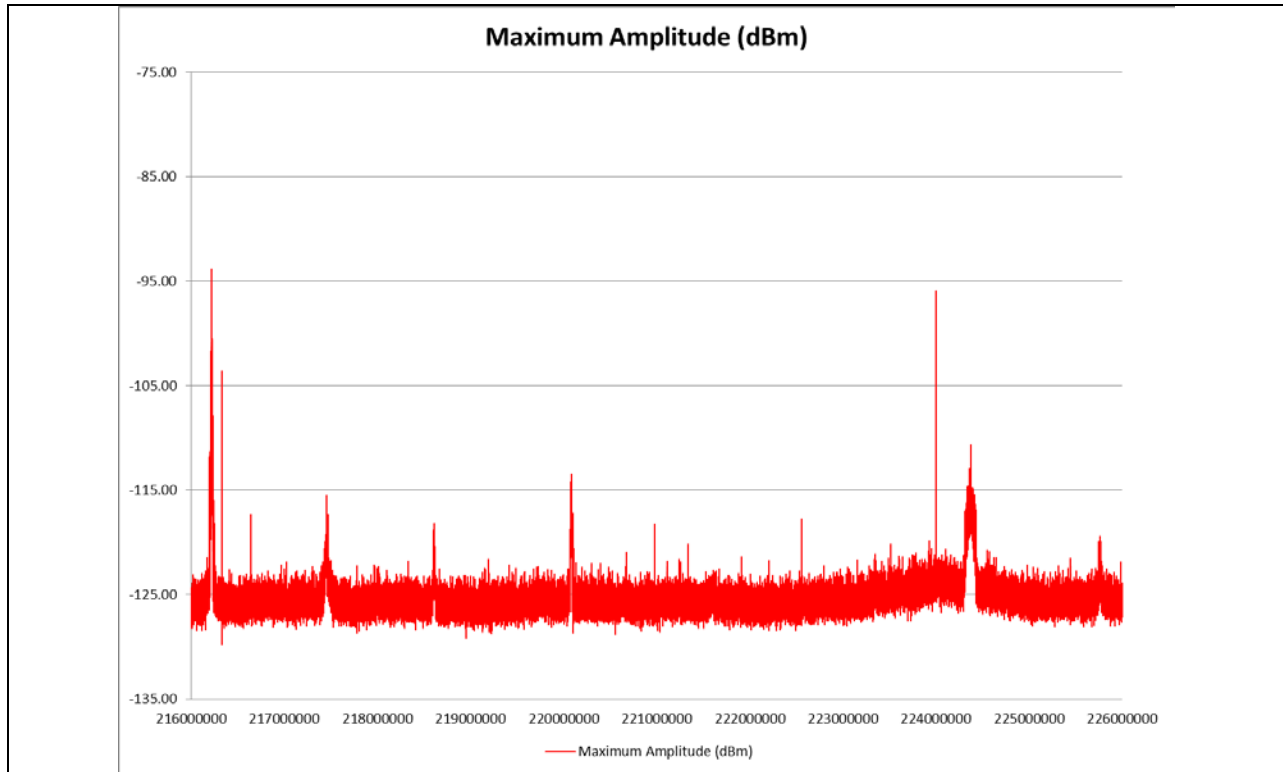

VHF TX Baseline

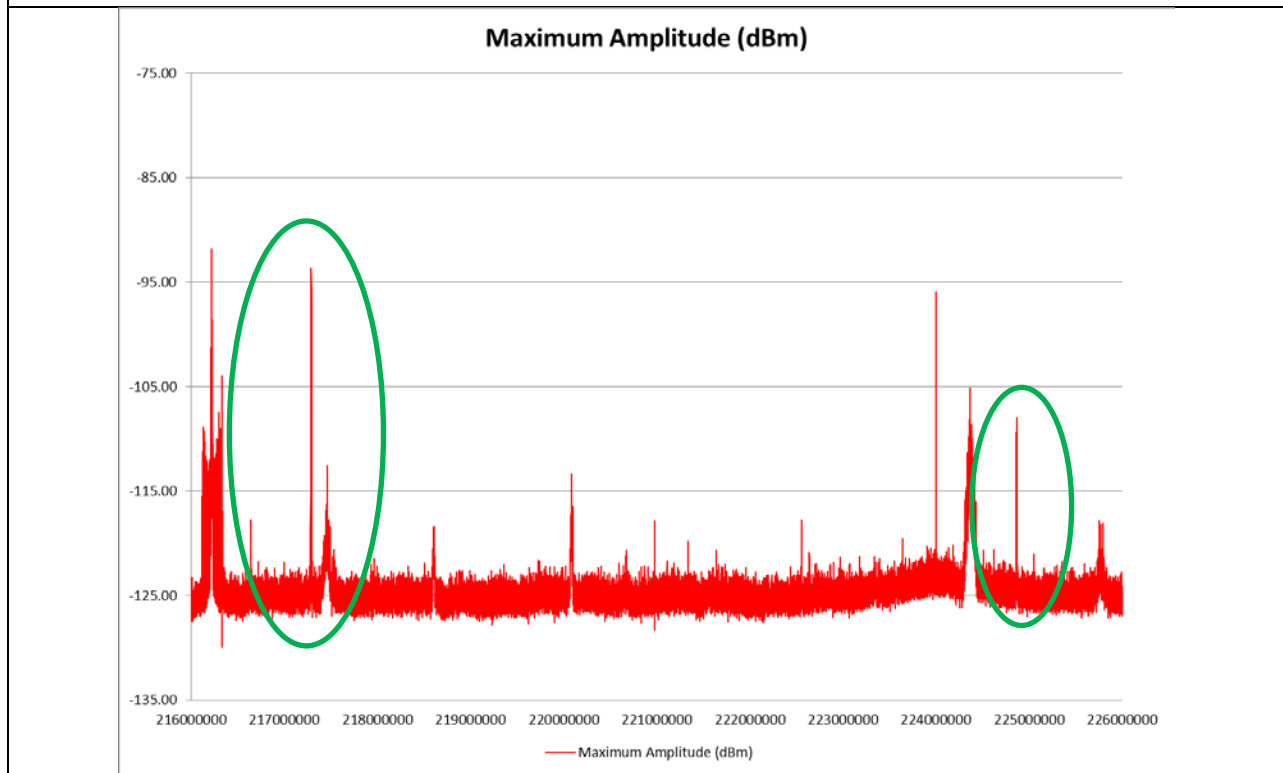

VHF TX with HOT/EOT TX

HOT XMIT

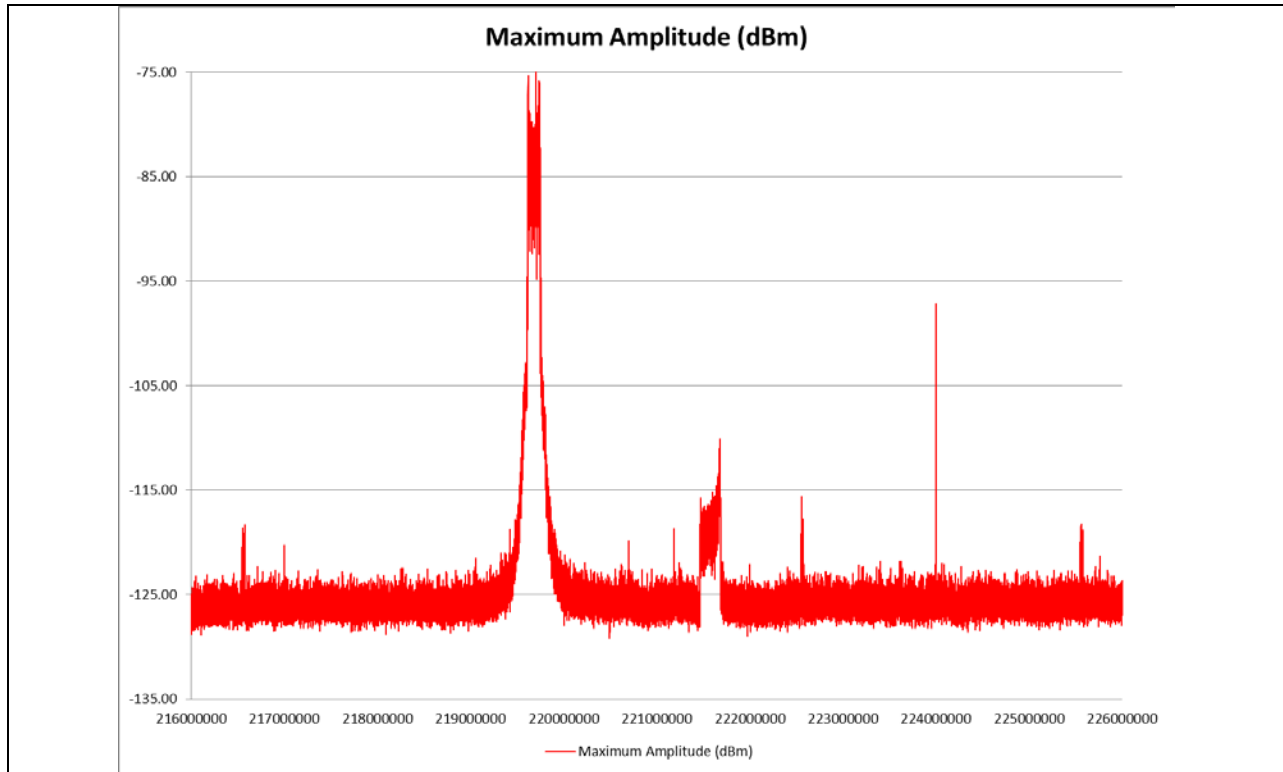

HOT/EOT TX Baseline

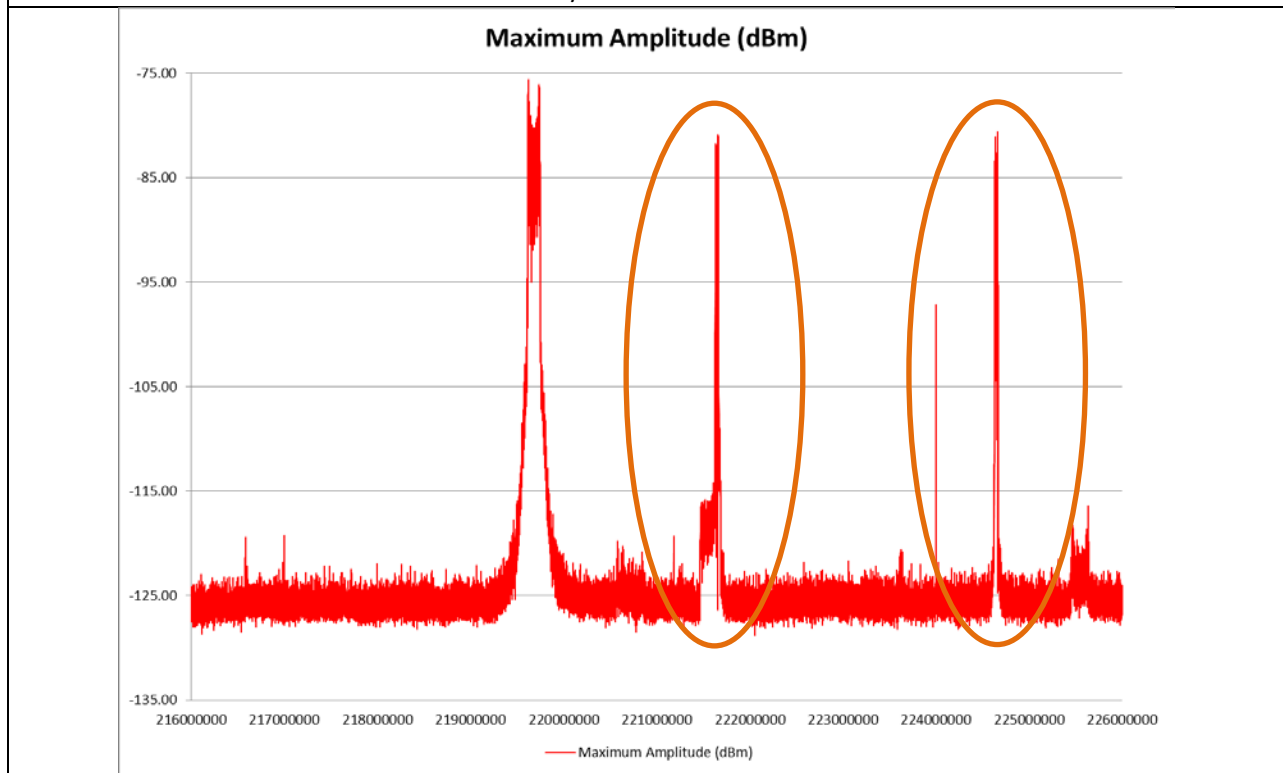

HOT/EOT TX with VHF TX

Notes:

In the VHF system the HOT transmit appears to cause some increased energy products in the PTC band (green circles). In the HOT system the VHF transmission causes some significant energy products (orange circles).

Transmit Intermodulation—Additional RFI

When transmitting on the AAR VHF Voice Radio, Significant RF Energy was measured in the 220 MHz Band. Testing on AAR Channel 13 (160.305MHz) and AAR Channel 26 produced multiple signals in the 220 MHz Band, 150 kHz to 200 kHz wide, at up to ~-77 dBm. Other signals were also present in the 220 MHz band varying in Amplitude from ~-105 dBm to ~-95 dBm. The Signals were Analog, and therefore could be demodulated, and were found to be carrying Broadcast Programming Audio. A scan of the FM Broadcast Band revealed signals with matching traffic for each of the 220 MHz signals demodulated. The plate on the left illustrates the 220 MHz Intermodulation Products when AAR Channel 26 is in use. The plate on the right illustrates the 220 MHz Intermodulation Products when AAR Channel 26 and AAR Channel 13 are in use. Careful perusal of the two plates reveals that the number of Intermodulation Product doubles. It is not uncommon for Railroad Yards to have several AAR Voice Channels in use.

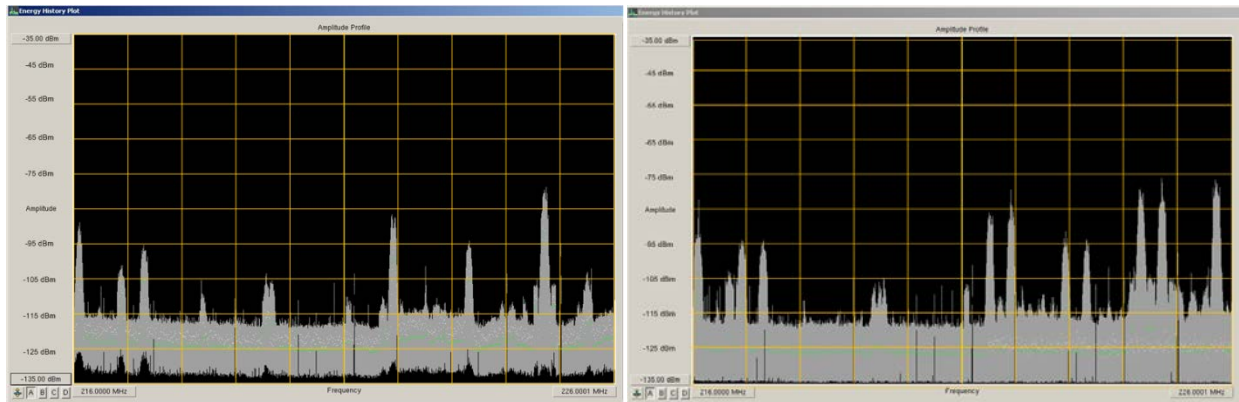

The next plate illustrates the FM Broadcast Band in Roanoke, Virginia, at the NS Shaffers Crossing Railroad Yard facilities. The signals have been identified.

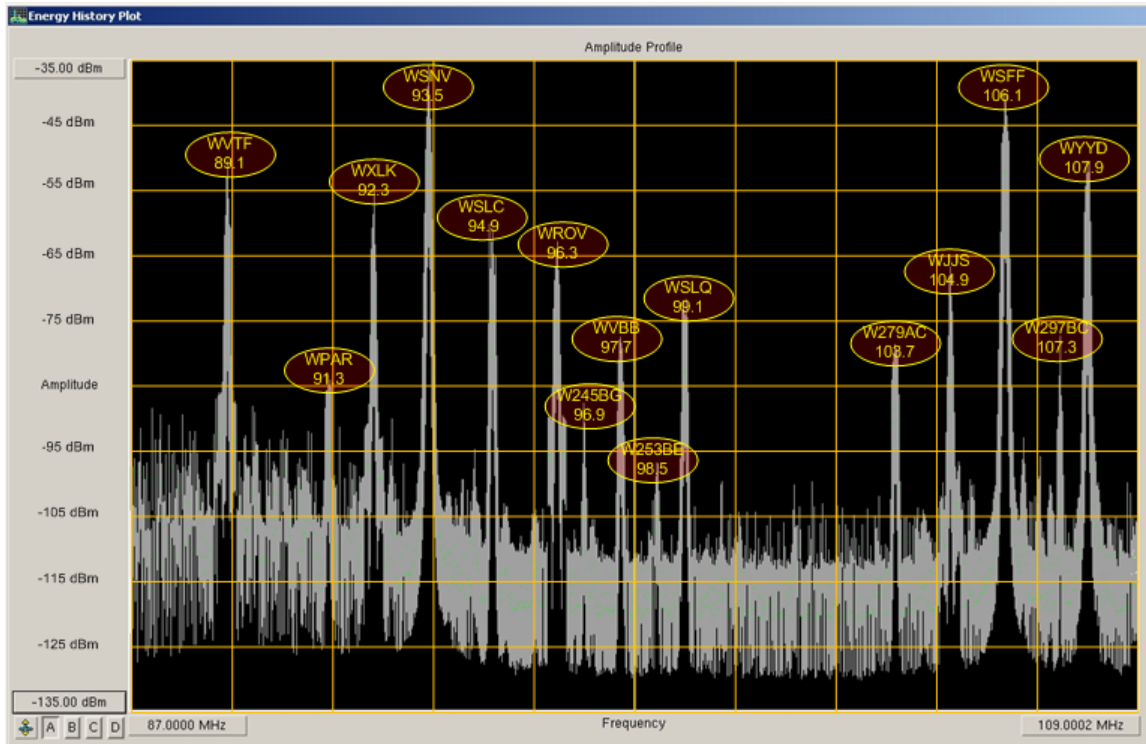

The next two plates illustrate how the Intermodulation Products are mapped back to the FM Broadcasters. The plate on the left, again illustrates the 220 MHz Intermodulation Products, with Identification, when AAR Channel 26 is in use. The plate on the right, again illustrates the 220 MHz Intermodulation Products, with Identification, when AAR Channel 26 and AAR Channel 13 are in use.

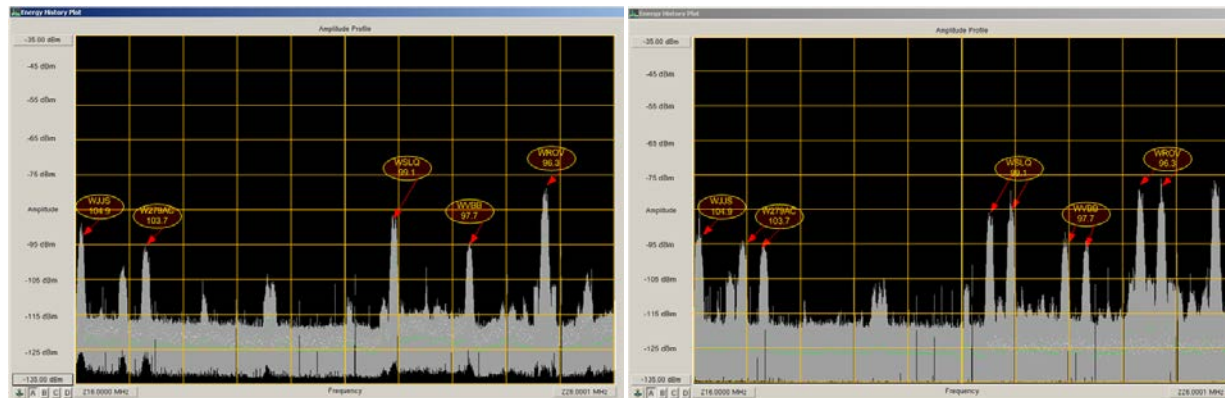

It is important to note that even though the FM Broadcasters' Audio Programming can be demodulated in the 220 MHz Intermodulation Products, the fault likely lies in the AAR VHF Voice Radio.

It is likely that the Intermodulation Products are being generated in the Power Amplifier stage of the AAR VHF Voice Radio. Most Land Mobile Radios employ a Low Pass Filter for FCC Compliance (to filter the 2nd and 3rd harmonics normally present in the Power Amplifier stage of any radio transmitter). A Band Pass Filter, with sharp cutoffs, would be a better choice than a Low Pass Filter, from a technical perspective, but economic concerns are involved in the decision to use a Low Pass Filter with a gradual cutoff (in order to control costs). Because of this, there is nothing in the radio's design to inhibit the FM Broadcast signals from entering the radio via the antenna port. Congruently, the lack of a steep cutoff in the Low Pass Filter allows 220 MHz products generated in the Power Amplifier stage to exit the radio via the antenna port, and are thus reradiated at a significant level. The diagram below is provided as a clarification.

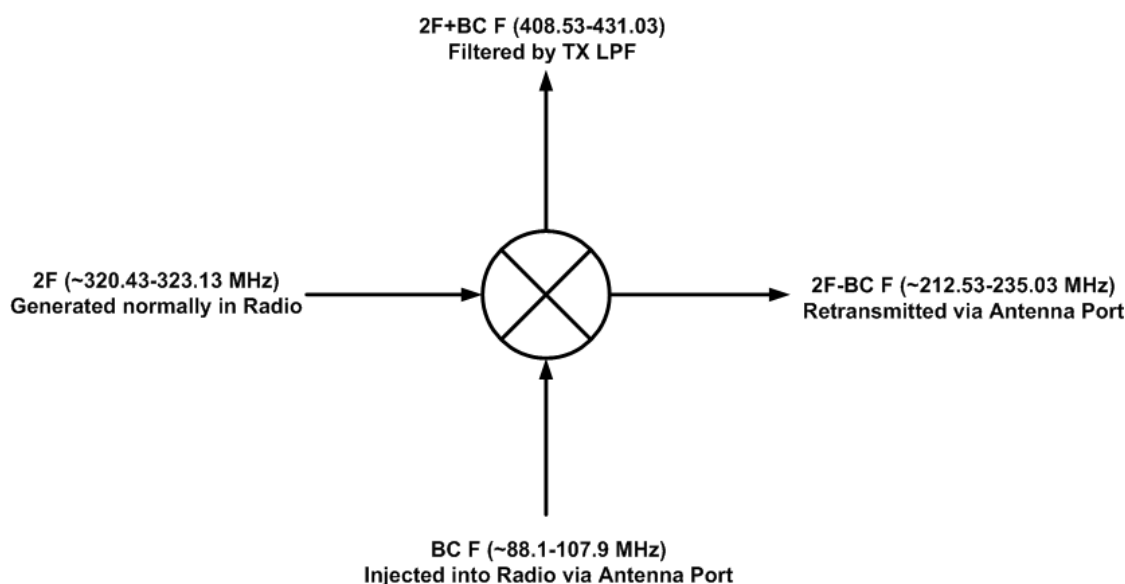

If the FM Broadcast signal is strong enough, other entry points into the radio should be considered. Such entry points may be through induction along the DC Power leads, the Microphone/Handset leads, the Control leads, or even the cases of the Control Head and the RF Deck. Mitigation may include Ferrite Toroids, RF Chokes, or Bypass Capacitors, or some combination, such as a Pi Network. Finger Stock or Braid may be needed to treat the RF Deck or Control Head cases for RF integrity. Similar consideration for Base Stations, Control Stations and Mobiles (Hyrail Radios) is recommended, especially in locations where high-level FM Broadcast signals are present. Portables (hand-held radios) are also capable of significant contribution, especially if operated near the PTC 220 MHz Locomotive Antennas. However, treating Portables is not usually feasible due to physical limitations and operational realities. Further testing is recommended to capture the entire scope of what is happening.

EMI Testing

The testing results showed some increases in the noise floor level while operating through the start-up and shut-down phases. There were not significant variations while changing through the various power conditions. A very minor difference between the conductor and engineer side noise floor (only about 1-2 DB) was indicated during testing. This may be attributed to the physical location of the antenna feed point relative to some on-board power sources, the pattern characteristic differences between the two antennas, or the routing of the two different cable bundles.

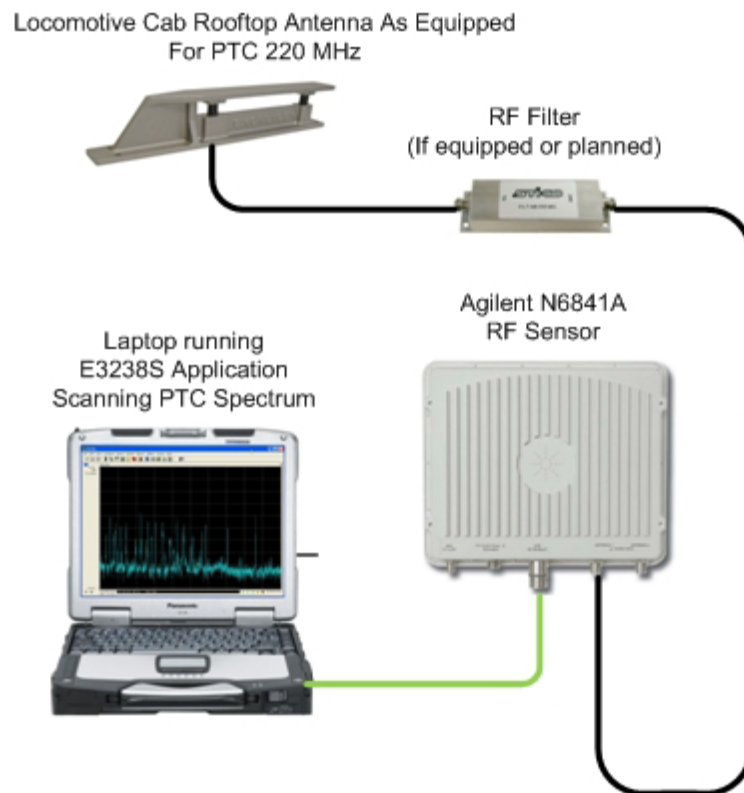

EMI Testing Configuration
Figure 20

	A	B	C	D	E	F	G	H	I	J	K	L	M	N	O
	Frequency	Bandwidth	Number Sweeps	Intercepts	Detections	Minimum Amplitude (DBm)	Average Amplitude (DBm)	Maximum Amplitude (DBm)	Minimum Bandwidth	Average Bandwidth	Maximum Bandwidth	Minimum Duration	Average Duration	Maximum Duration	Percent Occupancy
1	216000214	214	1314	85	10.00	-131.57	-125.99	-120.80	213.62	213.62	213.62	0.05	0.01	0.06	6.5%
2	216000427	214	1341	254	29.00	-131.92	-126.97	-120.89	213.62	213.62	213.62	0.05	0.01	0.27	18.9%
3	216000641	214	1334	330	60.00	-131.98	-126.83	-121.90	213.62	213.62	213.62	0.05	0.01	0.30	24.7%
4	216000855	214	1339	288	48.00	-131.80	-127.21	-121.00	213.62	213.62	213.62	0.05	0.01	0.20	21.5%
5	216001068	214	1341	190	23.00	-131.98	-126.77	-121.79	213.62	213.62	213.62	0.05	0.01	0.23	14.2%
6	216001282	214	1342	545	131.00	-131.94	-124.90	-119.33	213.62	214.01	427.25	0.05	0.02	0.38	40.6%
7	216001495	214	1340	420	92.00	-131.87	-125.24	-119.77	213.62	214.13	427.25	0.05	0.02	0.20	31.3%
8	216001709	214	1334	174	16.00	-131.86	-126.68	-120.89	213.62	214.85	427.25	0.05	0.00	0.11	13.0%
9	216001923	214	1342	361	71.00	-131.98	-126.29	-120.77	213.62	213.62	213.62	0.05	0.02	1.45	26.9%
10	216002136	214	1336	406	82.00	-131.95	-125.97	-119.31	213.62	213.62	213.62	0.05	0.01	0.25	30.4%
11	216002350	214	1342	252	39.00	-131.94	-126.71	-121.37	213.62	213.62	213.62	0.05	0.01	0.11	18.8%
12	216002564	214	1329	262	41.00	-131.98	-127.02	-122.01	213.62	213.62	213.62	0.05	0.01	0.16	19.7%
13	216002777	214	1341	329	59.00	-131.98	-125.90	-119.16	213.62	214.27	427.25	0.05	0.01	0.16	24.5%
14	216002991	214	1338	463	102.00	-131.92	-125.54	-119.63	213.62	213.62	213.62	0.05	0.02	0.27	34.6%
15	216003204	214	1340	307	59.00	-131.84	-125.81	-120.77	213.62	213.62	213.62	0.05	0.01	0.16	22.9%
16	216003418	214	1342	305	48.00	-131.71	-126.40	-119.80	213.62	214.32	427.25	0.05	0.01	0.16	22.7%
17	216003632	214	1341	301	53.00	-131.80	-126.54	-120.70	213.62	213.62	213.62	0.05	0.01	0.20	22.4%
18	216003845	214	1337	289	56.00	-131.98	-127.10	-120.43	213.62	214.36	427.25	0.05	0.01	0.22	21.6%
19	216004059	214	1336	308	58.00	-131.97	-127.08	-122.06	213.62	213.62	213.62	0.05	0.01	0.27	23.1%
20	216004273	214	1338	298	53.00	-131.98	-126.85	-120.96	213.62	214.34	427.25	0.05	0.01	0.20	22.3%
21	216004486	214	1339	332	65.00	-131.80	-127.04	-121.12	213.62	213.62	213.62	0.05	0.01	0.33	24.8%
22	216004700	214	1341	381	75.00	-131.98	-126.40	-121.15	213.62	213.62	213.62	0.05	0.02	0.23	28.4%
23	216004913	214	1335	277	44.00	-131.97	-127.08	-120.32	213.62	213.62	213.62	0.05	0.01	0.11	20.7%
24	216005127	214	1337	296	49.00	-131.98	-127.02	-121.40	213.62	213.62	213.62	0.05	0.01	0.22	22.1%
25	216005341	214	1341	327	65.00	-131.97	-127.02	-119.80	213.62	213.62	213.62	0.05	0.01	0.16	24.4%
26	216005554	214	1342	293	52.00	-131.98	-126.89	-121.16	213.62	213.62	213.62	0.05	0.01	0.20	21.8%
27	216005768	214	1335	311	56.00	-131.87	-127.15	-121.00	213.62	214.31	427.25	0.05	0.01	0.11	23.3%
28	216005981	214	1338	293	54.00	-131.98	-126.86	-120.96	213.62	214.35	427.25	0.05	0.01	0.13	21.9%
29	216006195	214	1342	312	59.00	-131.97	-126.99	-120.94	213.62	213.62	213.62	0.05	0.02	1.45	23.2%
30	216006409	214	1338	302	55.00	-131.98	-127.35	-122.10	213.62	214.33	427.25	0.05	0.01	0.16	22.6%
31	216006622	214	1342	322	60.00	-131.98	-127.00	-121.25	213.62	214.29	427.25	0.05	0.01	0.25	24.0%
32	216006836	214	1339	296	49.00	-131.92	-127.08	-122.56	213.62	213.62	213.62	0.05	0.01	0.25	22.1%
33	216007050	214	1341	325	63.00	-131.97	-127.04	-121.10	213.62	214.94	427.25	0.05	0.01	0.23	24.2%
34	216007263	214	1336	313	64.00	-131.98	-127.22	-121.77	213.62	213.62	213.62	0.05	0.01	0.31	23.4%

Energy File Data Format
Figure 21

This is a sample of the data captured on each locomotive, each excel file is approximately 10 MB, comprised 46000 frequency information points and the associated amplitude, duration, bandwidth and percent occupancy information. Without a Locomotive-scaled Faraday Cage and Anechoic Chamber, it is not possible to fully isolate the locomotive from its environment. However, by perusing the following charts, with less focus on the discrete signals present (spikes), and more focus on the overall changes between Locomotive operational states, it is possible to characterize the noise. The Energy Files are provided in the Appendix to permit further manipulation of the data, if desired.

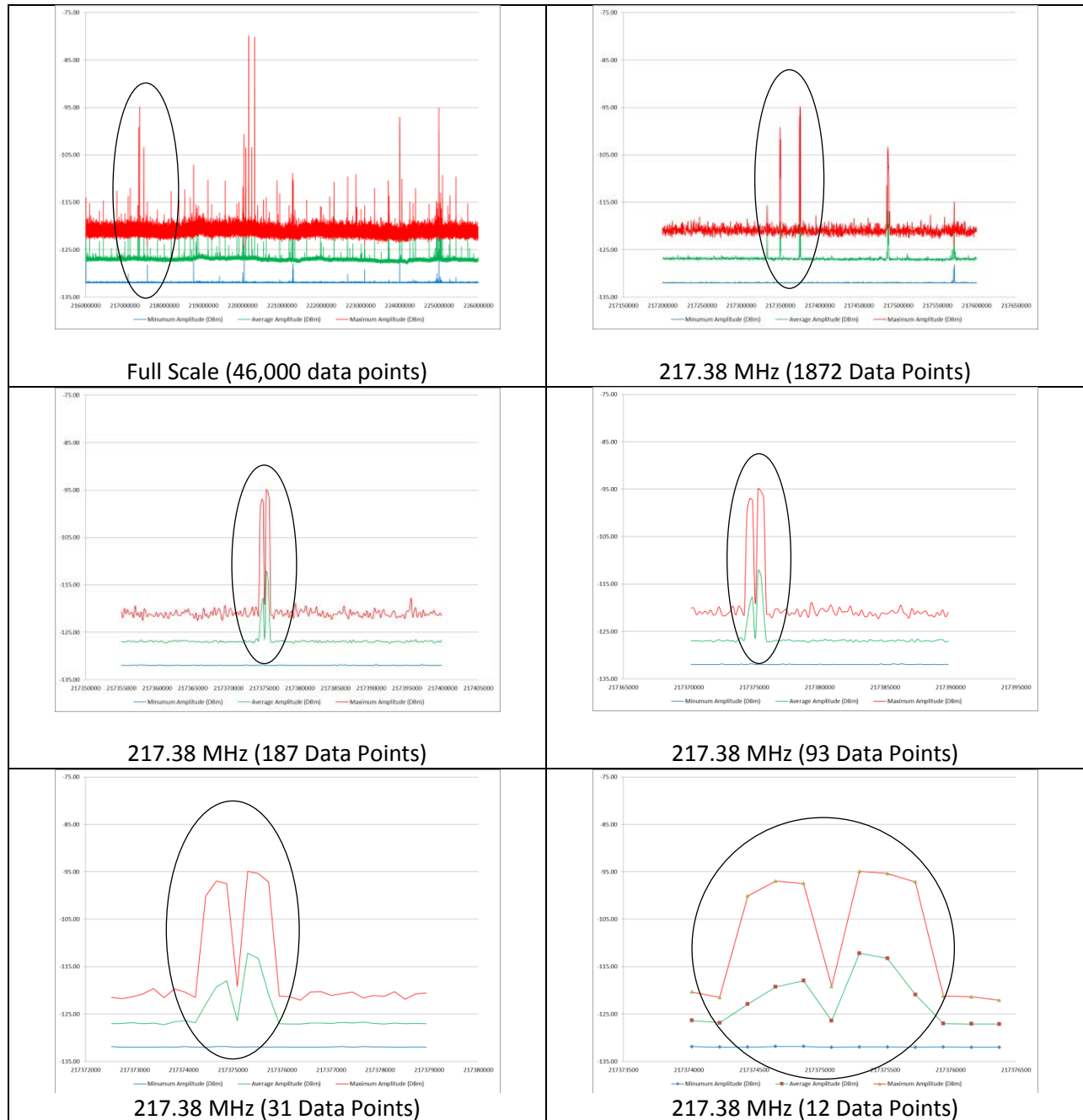
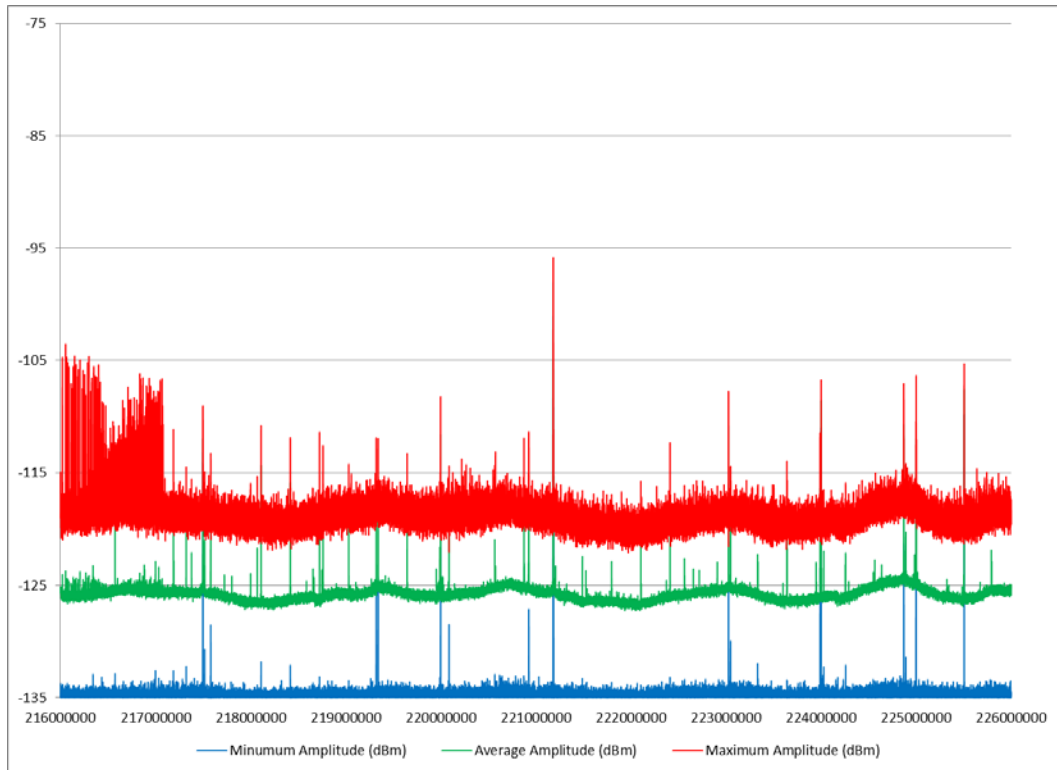
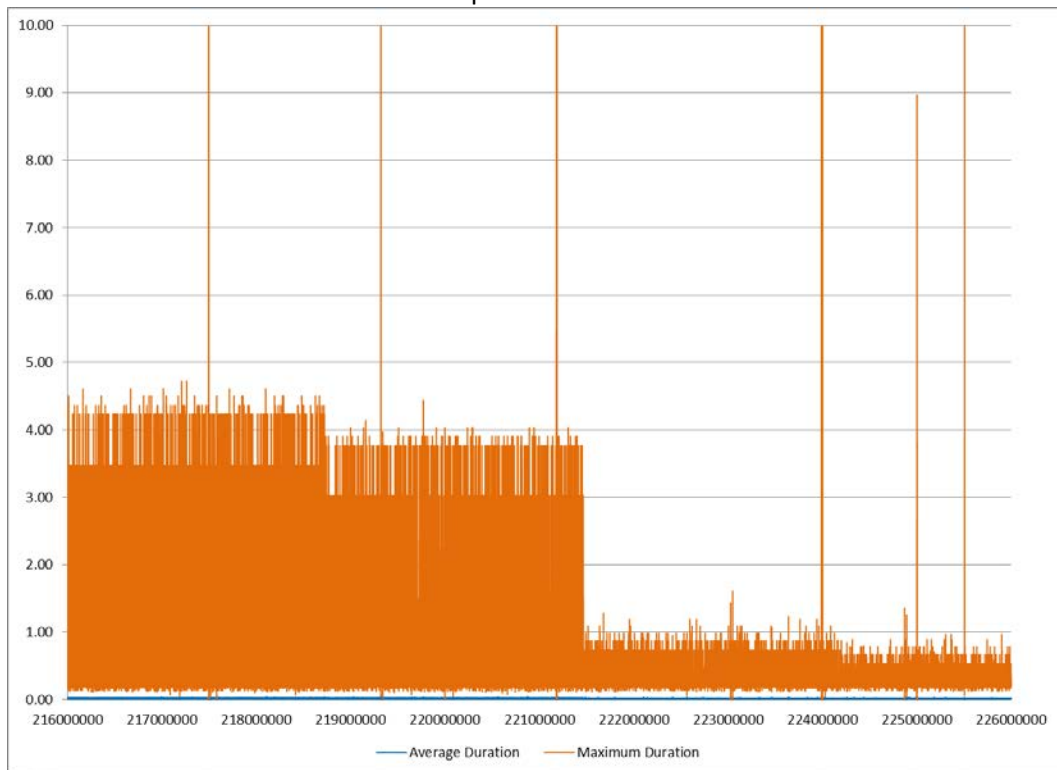

Figure 22

The following charts represent XY scatter chart with lines in EXCEL. Because of the amount of information shown in each chart the data might appear to be a spectrograph exported from a spectrum analyzer, rather than a record of the signal amplitude levels or duration information extracted and plotted from the energy history files that it actually represents. In Figure 25, three different resolutions of the information have been created to show the individual data points and how they are interconnected.



Amplitude Profile



Duration Profile

NS 8898 Engine Off State

Figure 23

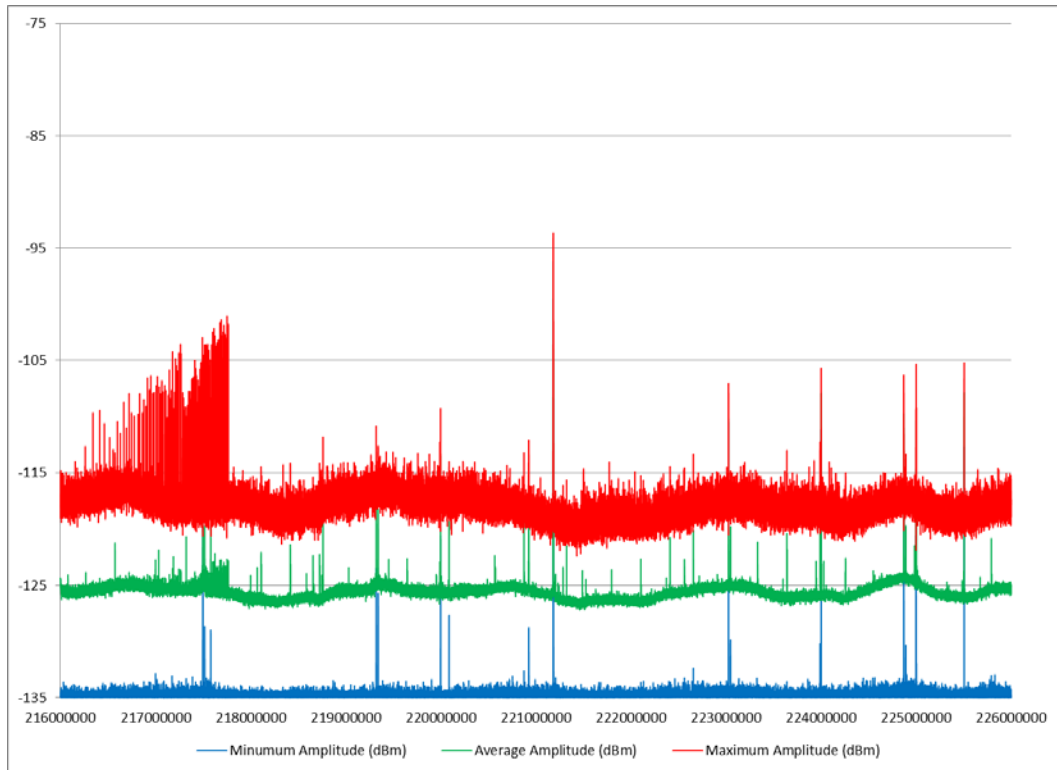

Amplitude Profile

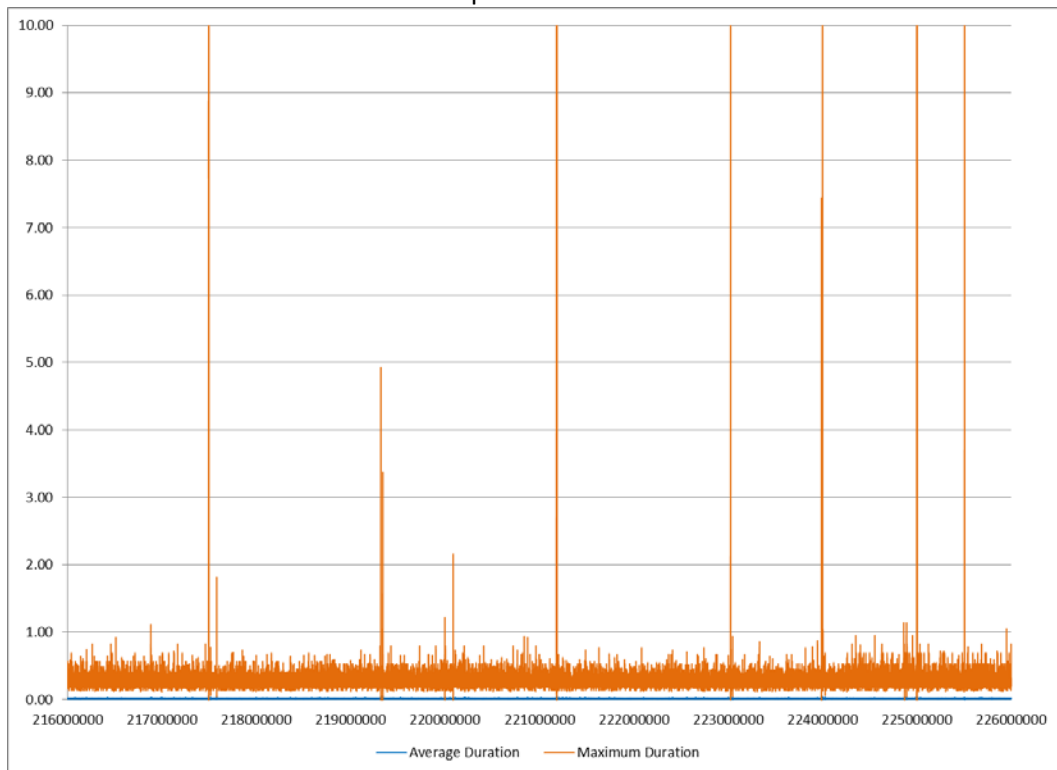

Duration Profile

NS 8898 Startup Sequence

Figure 24

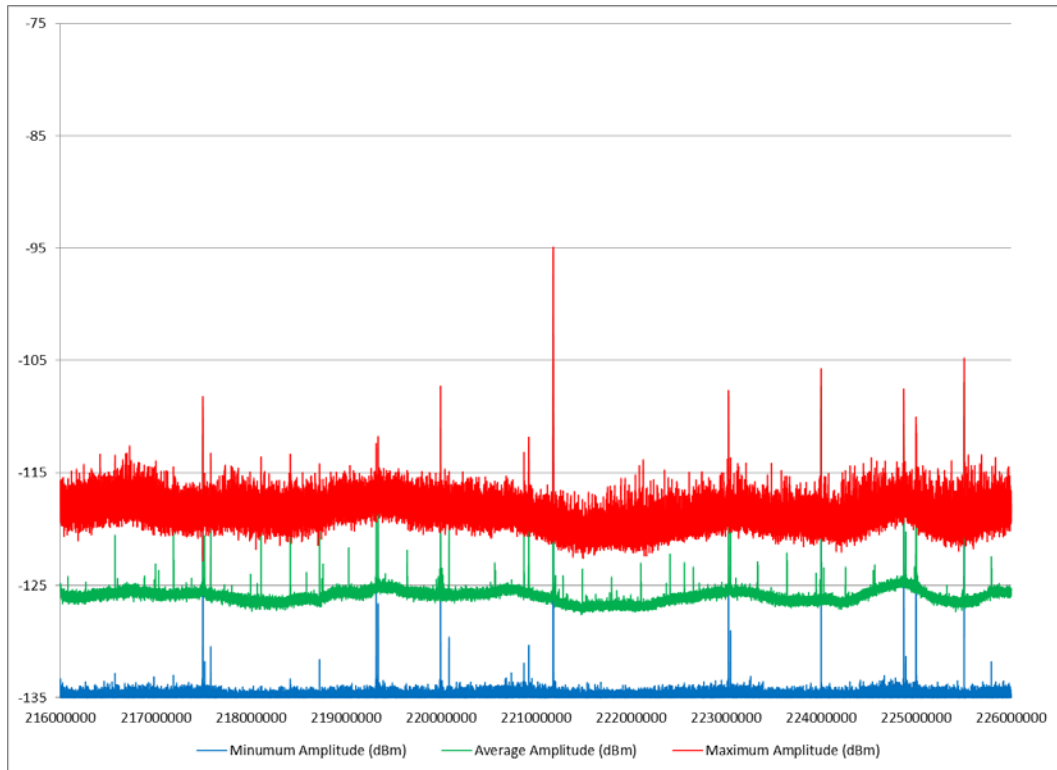

Amplitude Profile

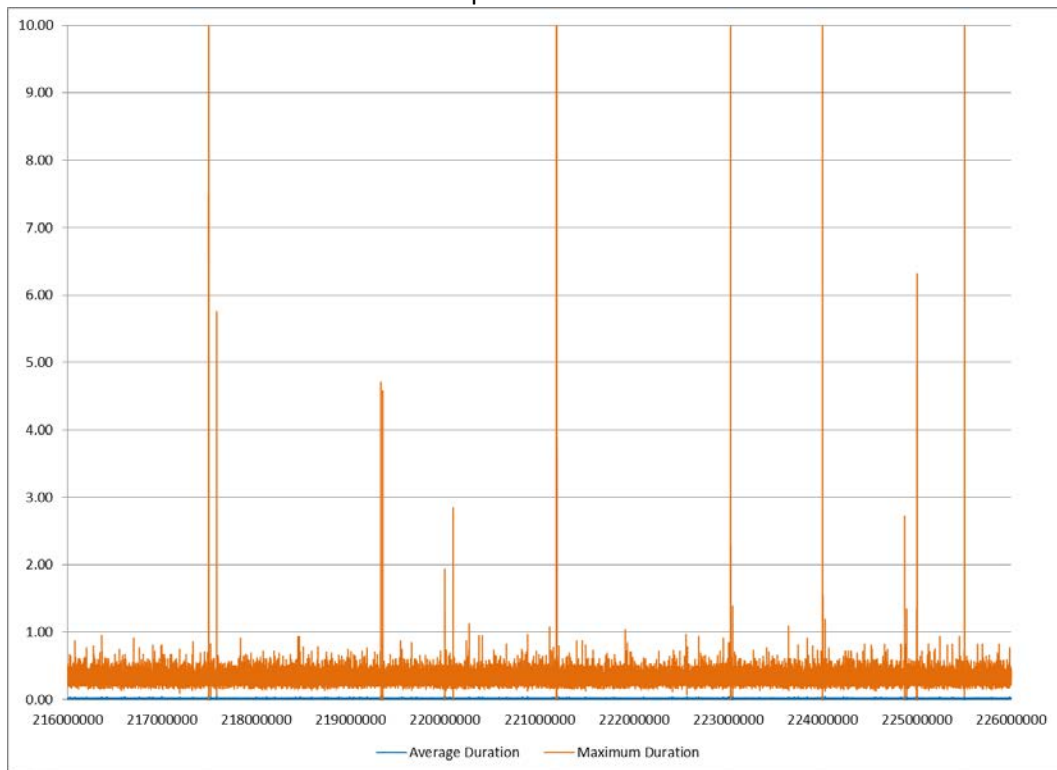

Duration Profile

NS 8898 Engine Idle

Figure 25

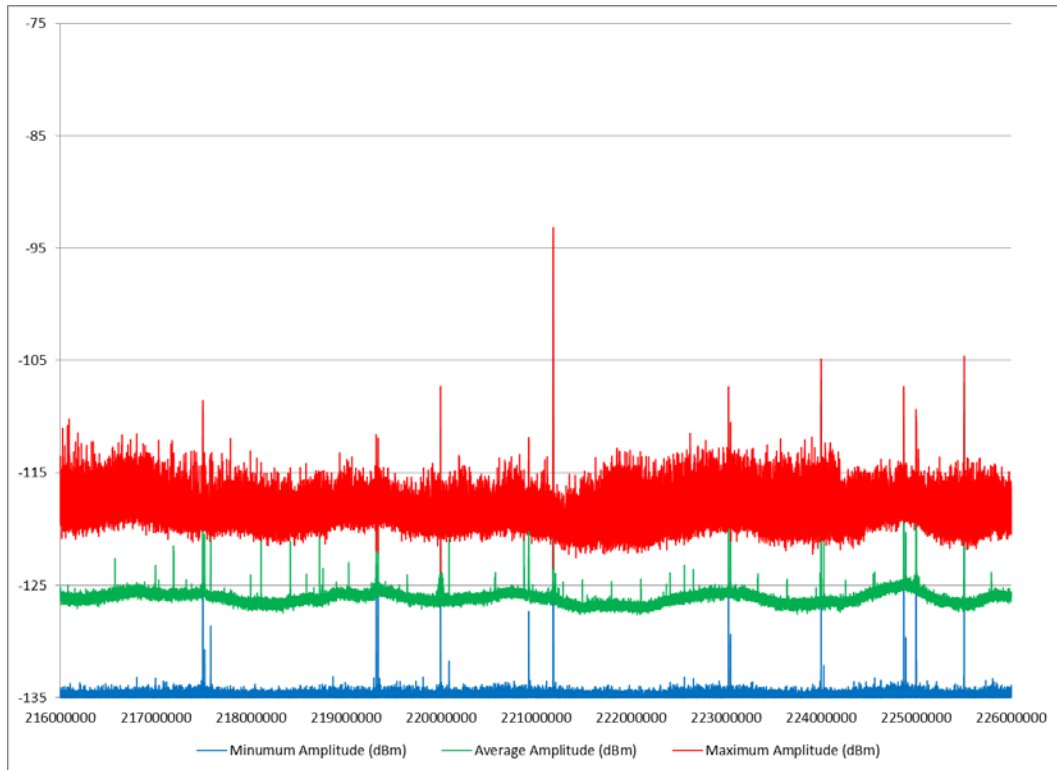

Amplitude Profile

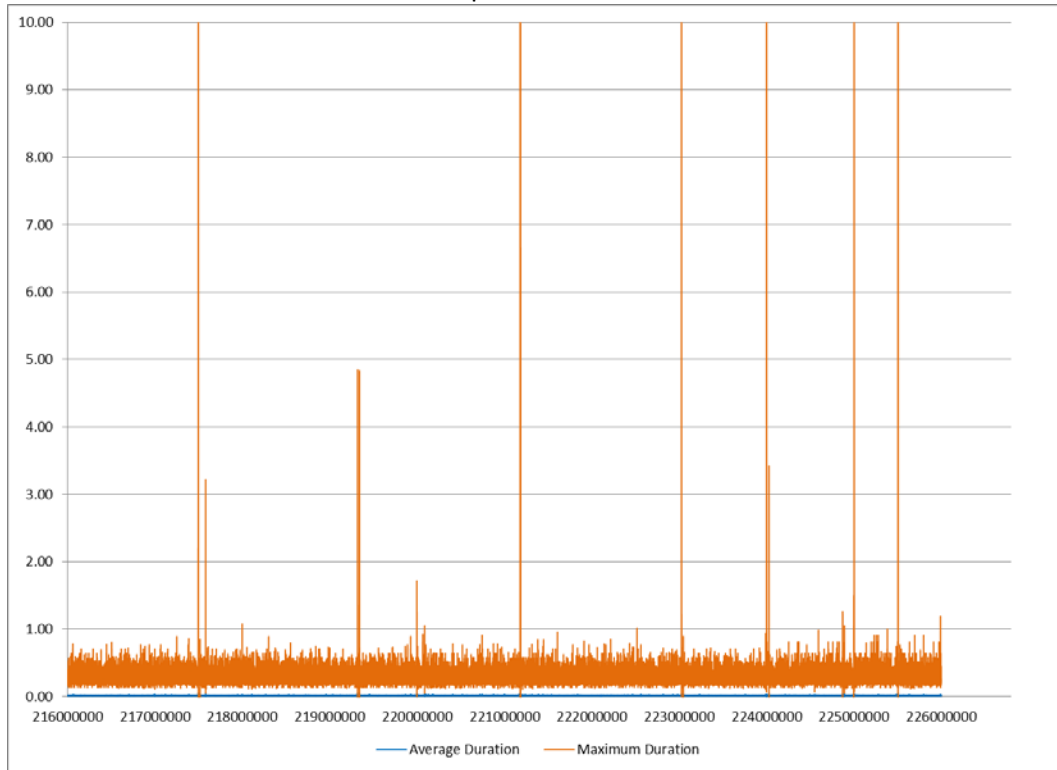

Duration Profile
NS 8898 Notch 1
Figure 26

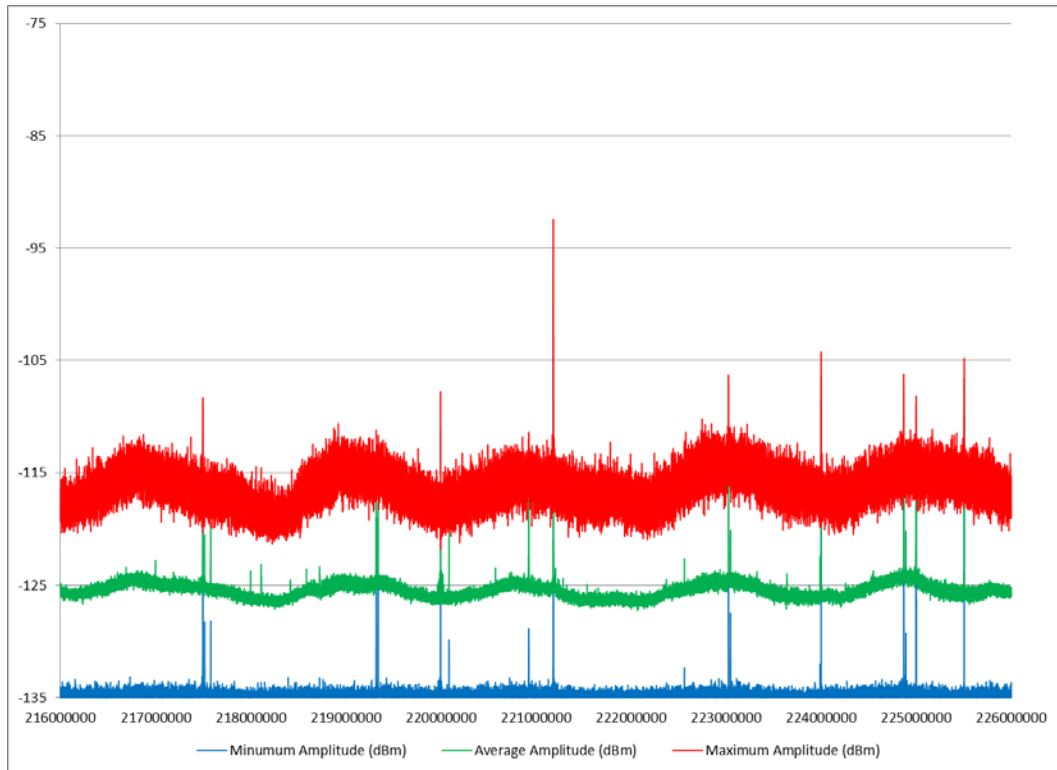

Amplitude Profile

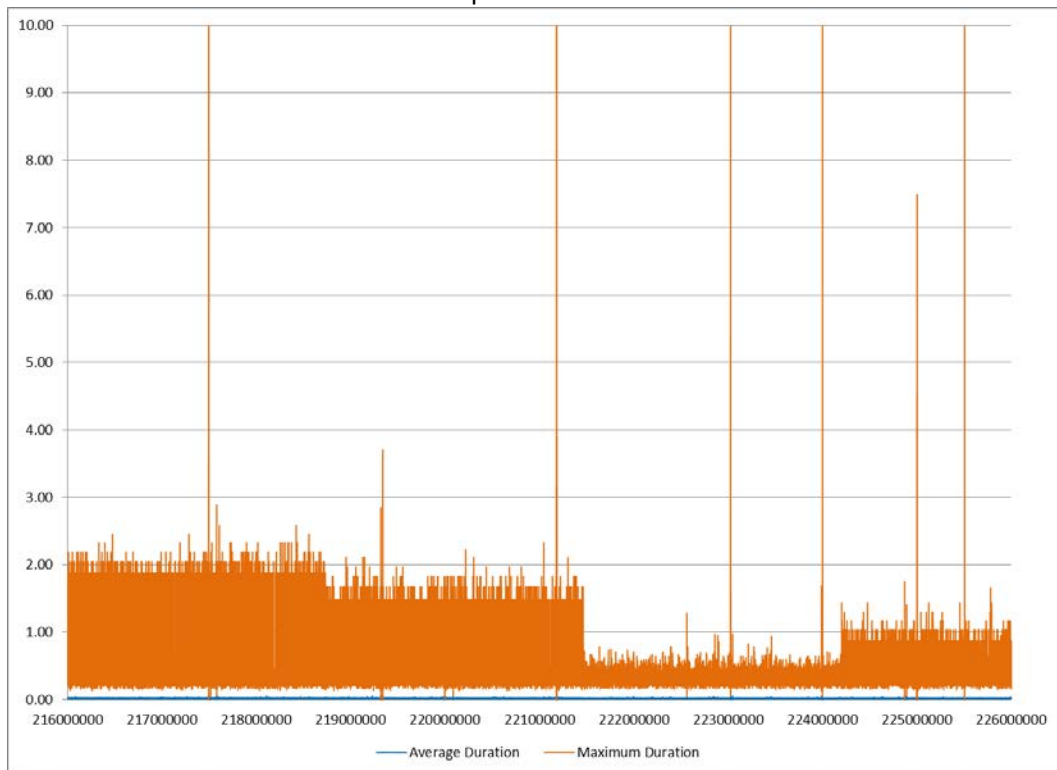

Duration Profile
NS 8898 Notch 2
Figure 27

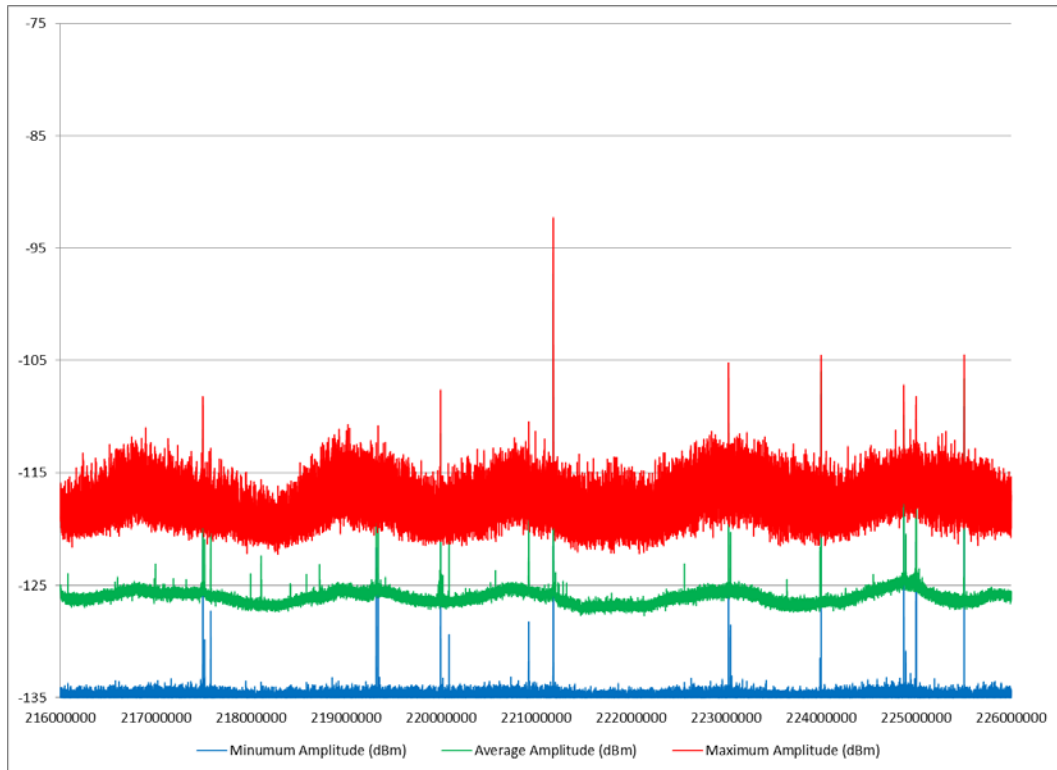

Amplitude Profile

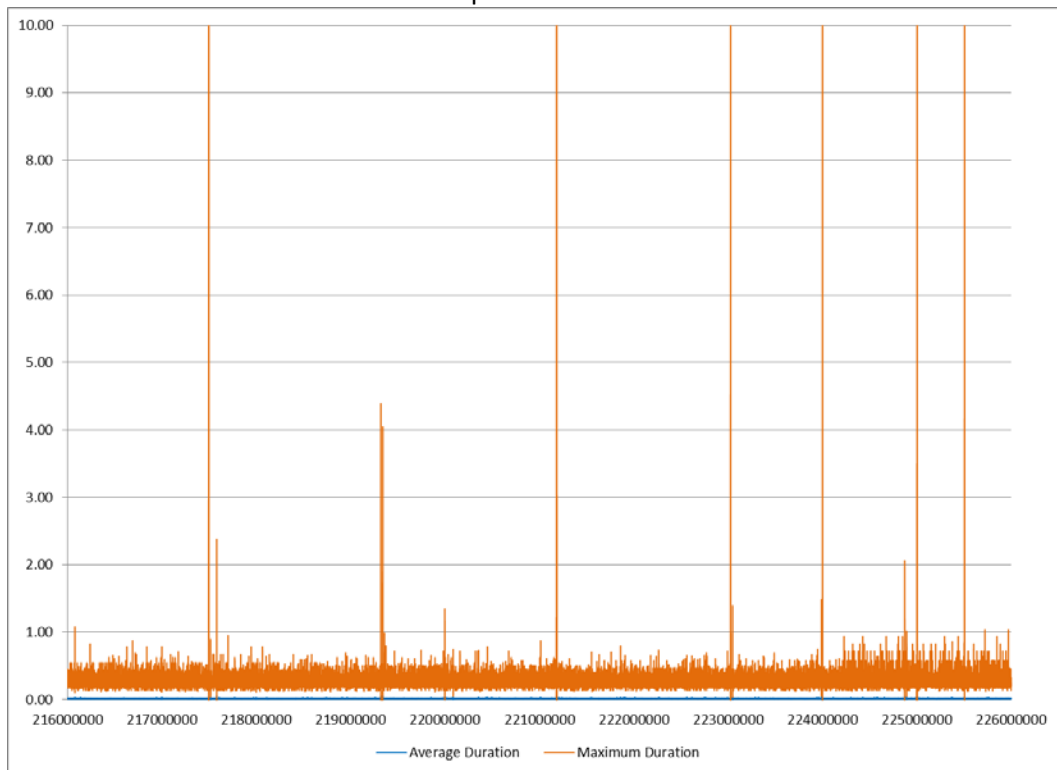

Duration Profile
NS 8898 Notch 3
Figure 28

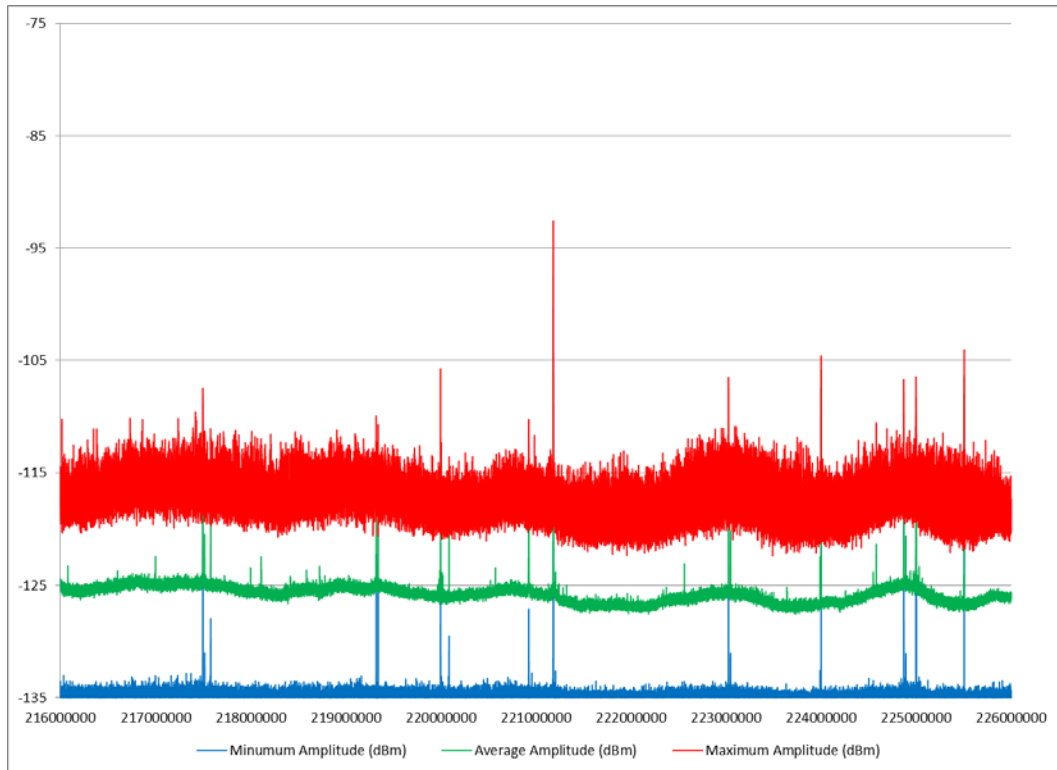

Amplitude Profile

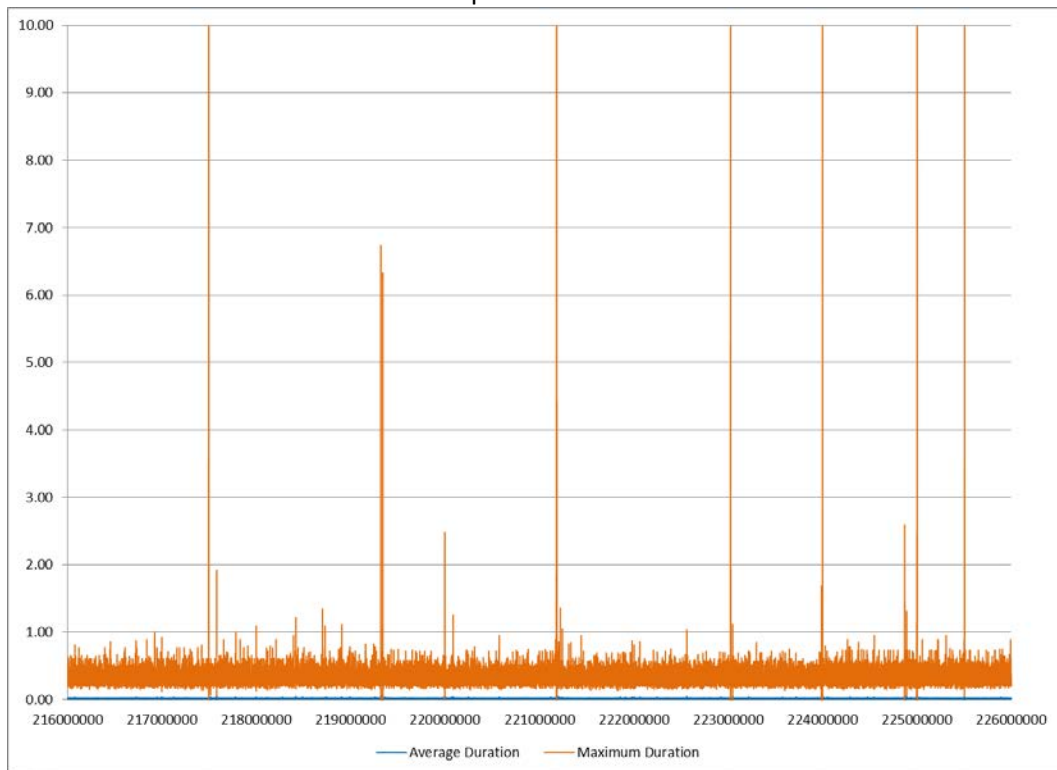

Duration Profile

NS 8898 Notch 4

Figure 29

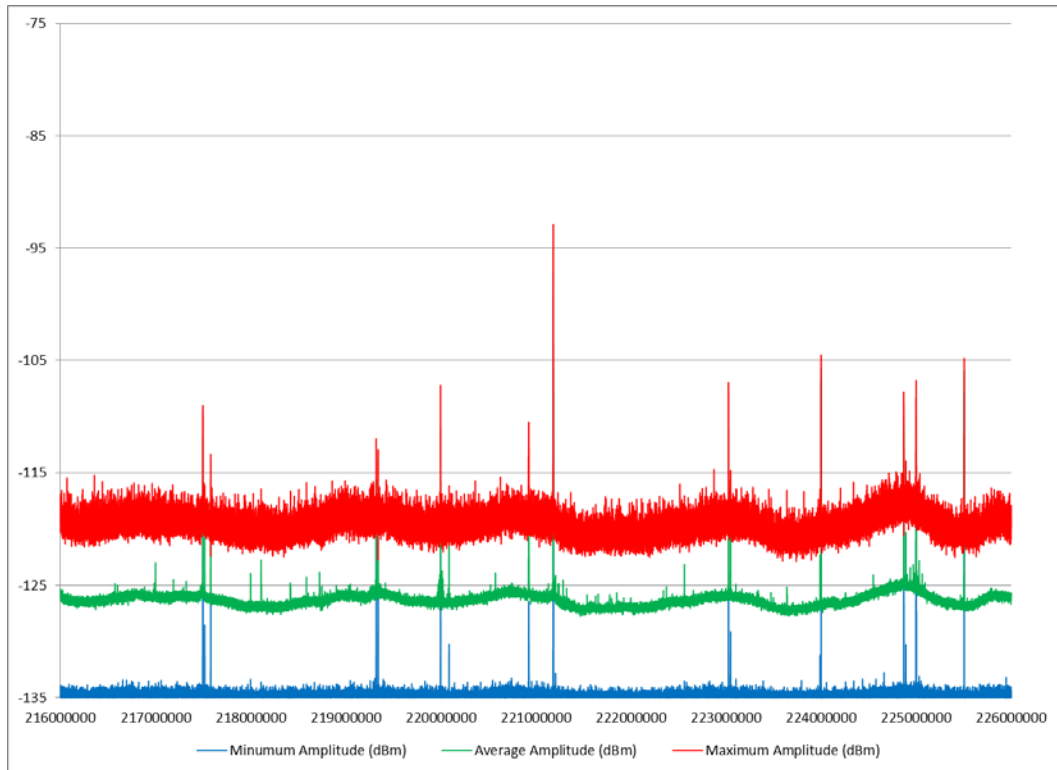

Amplitude Profile

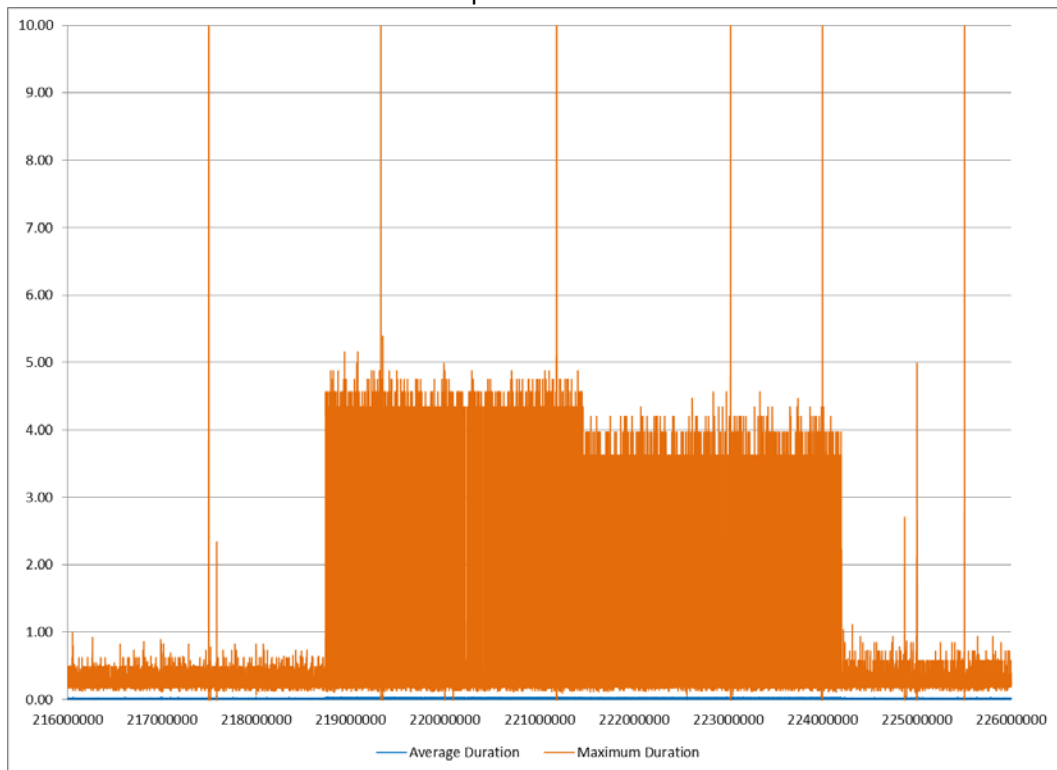

Duration Profile
NS 8898 Notch 5
Figure 30

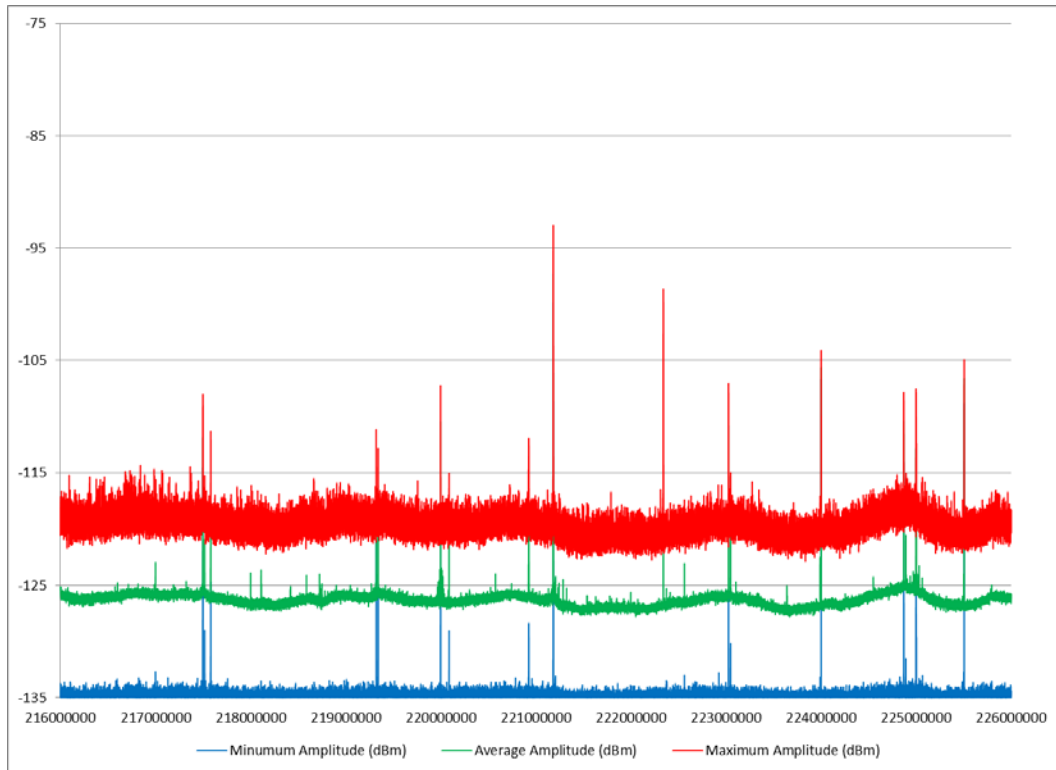

Amplitude Profile

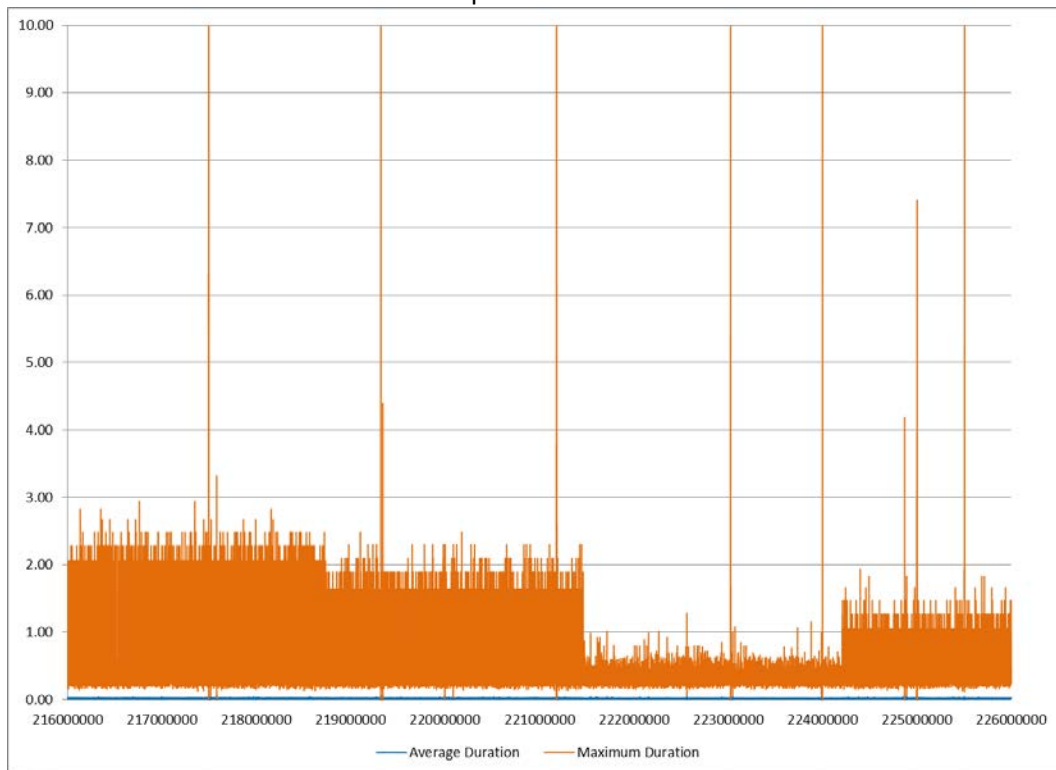

Duration Profile
NS 8898 Notch 6
Figure 31

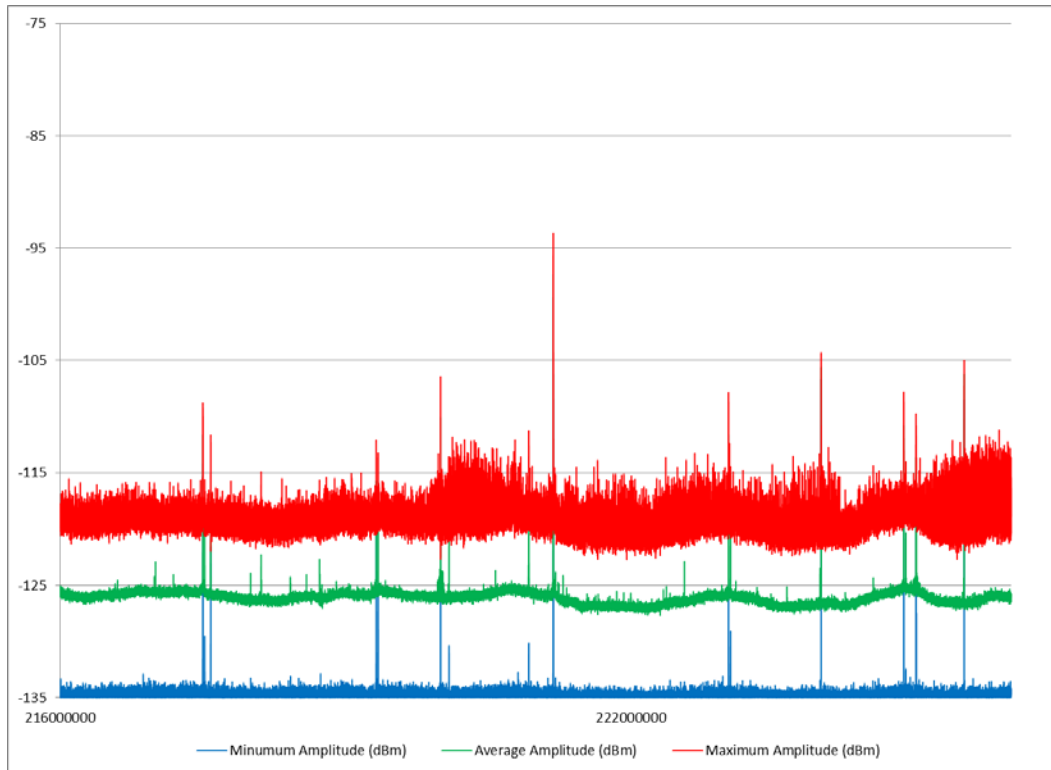

Amplitude Profile

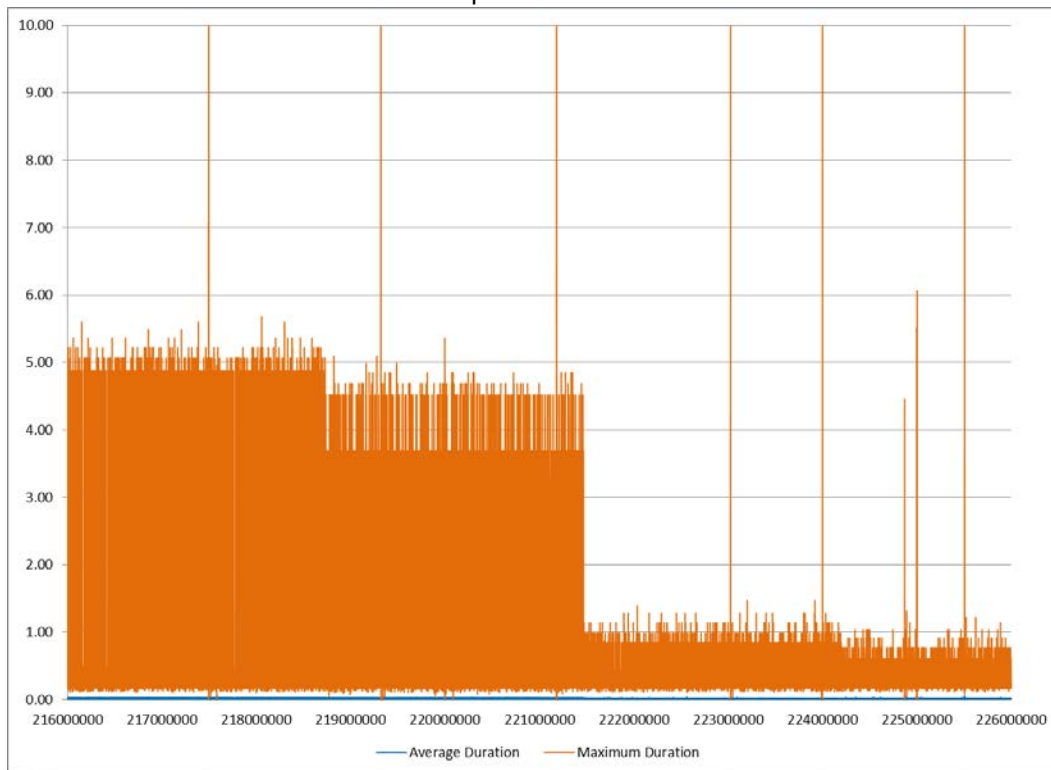

Duration Profile
NS 8898 Notch 7
Figure 32

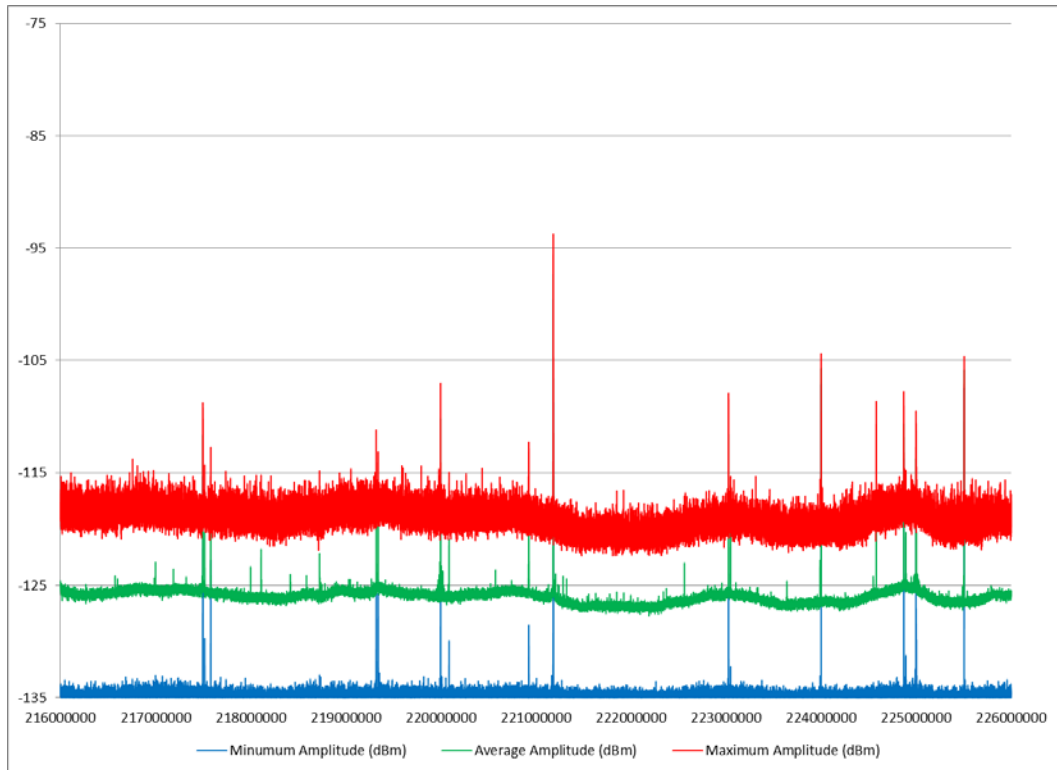

Amplitude Profile

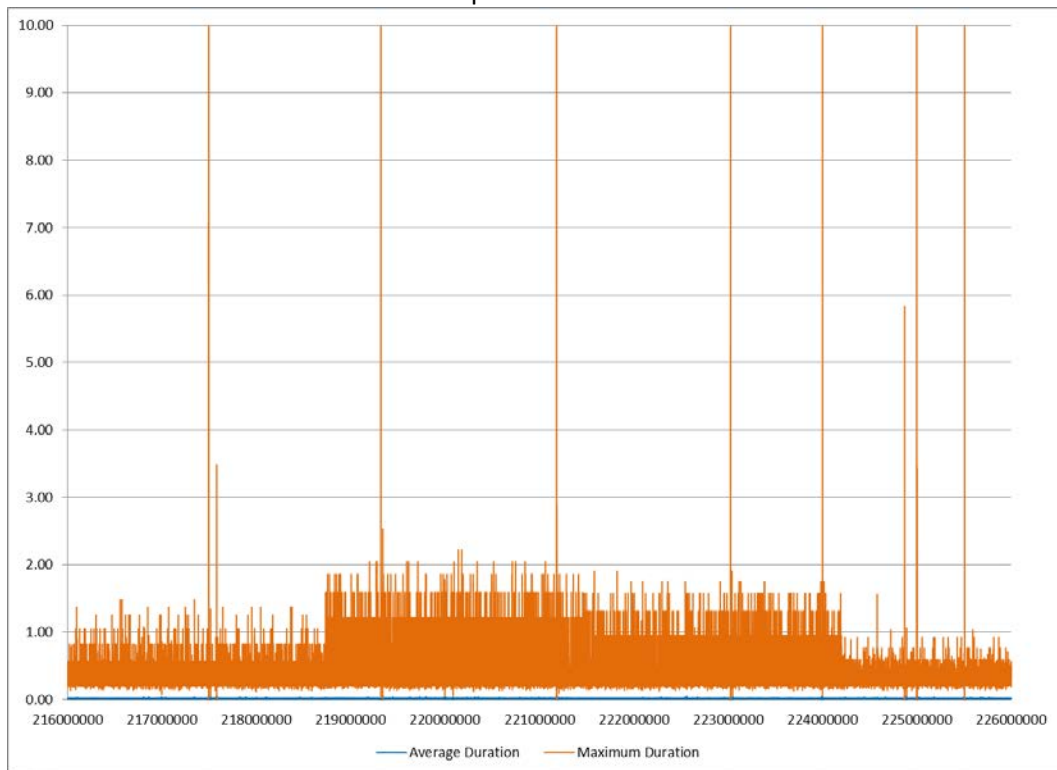

Duration Profile
NS 8898 Notch 8
Figure 33

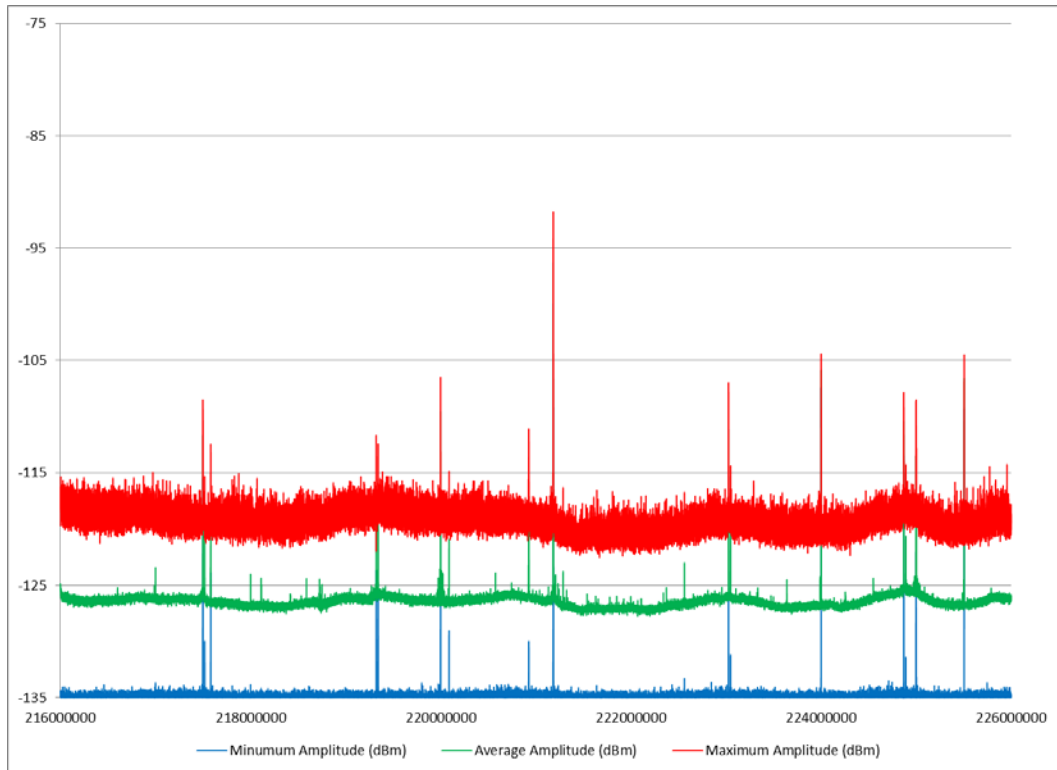

Amplitude Profile

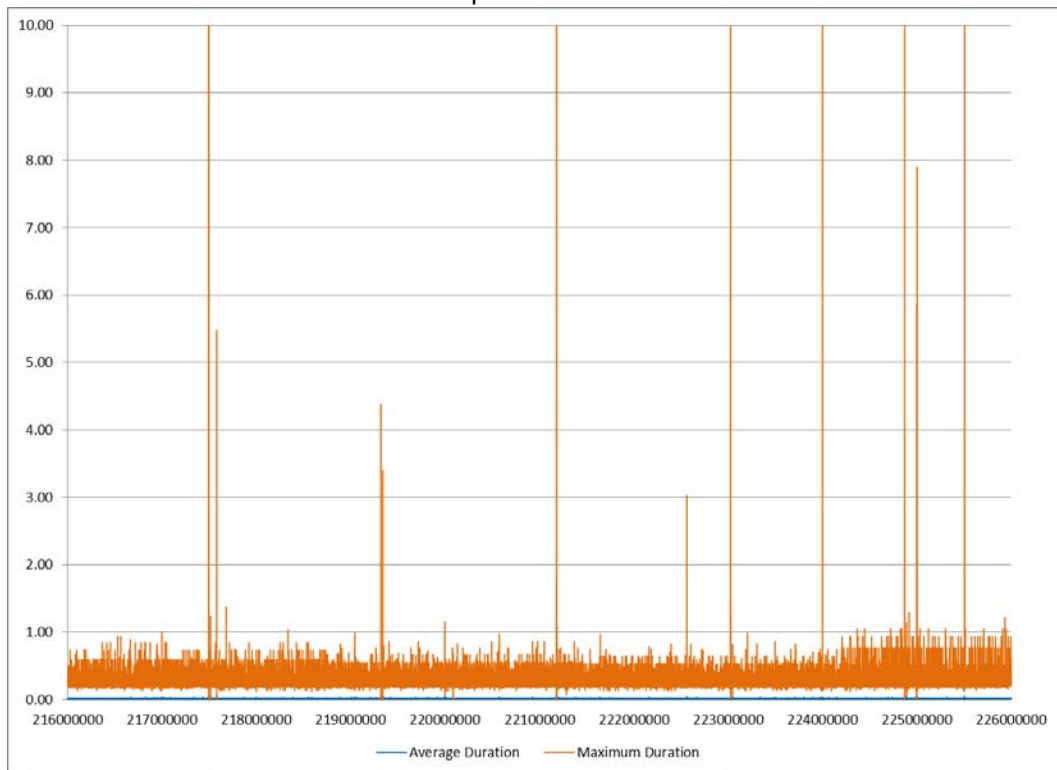

Duration Profile

NS 8898 Shutdown Sequence

Figure 34

BER Testing

The purpose of this test is to determine the impact on receiving PTC transmissions in the locomotive noise environment, with the focus on capturing the minimum signal level needed for radio network planning. To accomplish this, a PTC Locomotive Radio (F3) was connected through a Directional Coupler to a Signal Generator equipped with an attenuator pad, and to the worse-case locomotive PTC Antenna. See Figure 35.

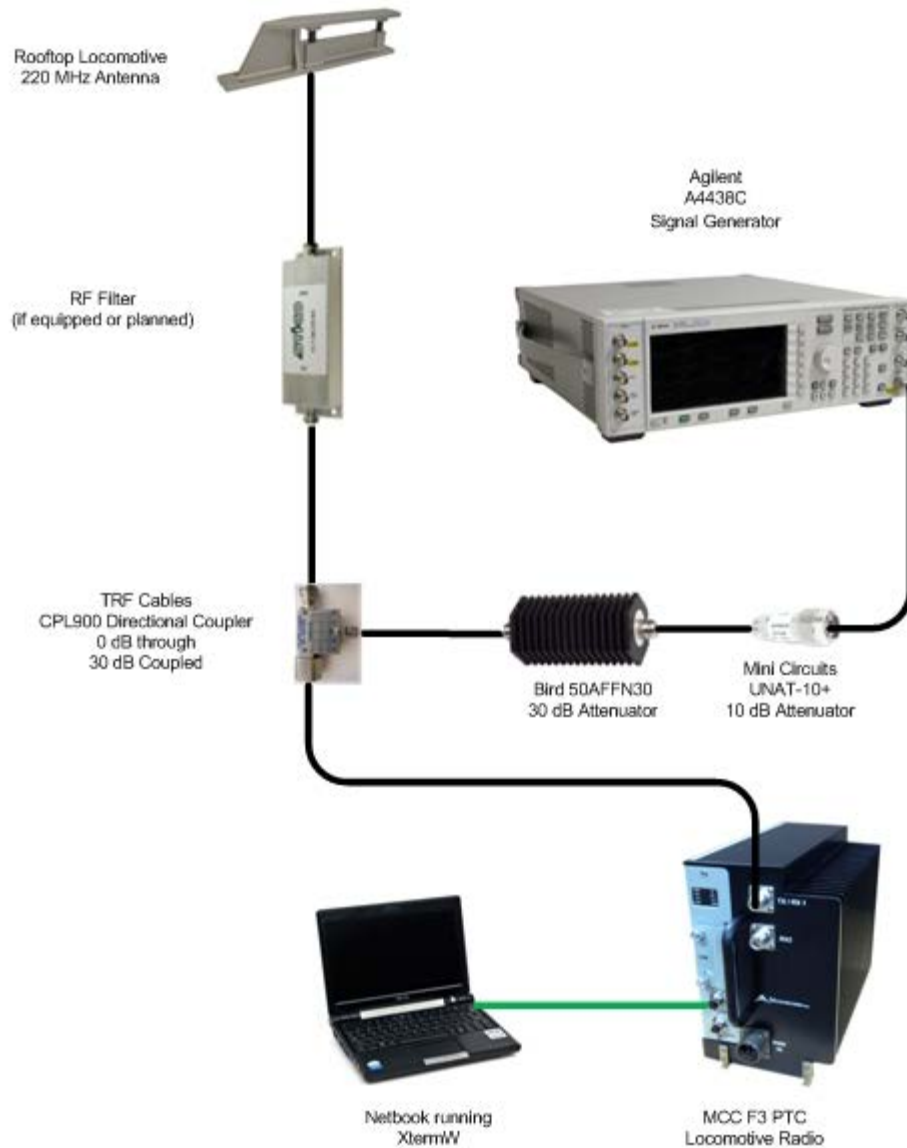

BER Testing Configuration
Figure 35

The PTC Radio's design is based on a Receiver noise floor of -123 dBm, and a C/N ratio (for sustaining a BER of E-4) of 11 dB, and a C/I (for sustaining a BER of E-4) of 14 decibels.

To establish a baseline, the PTC Antenna was disconnected from the Directional Coupler port, and the port was terminated. This effectively isolated the radio from the noise environment. The Signal Generator was configured to send a Test Pattern, and the signal level was set so that a BER of E-4 was sustainable. In this configuration, the PTC Radio was able to report a BER of E-4 at -113 dBm. Note that this radio, under these test conditions, was performing slightly better than spec with a C/N of 10 decibels.

The PTC Antenna was then reconnected, and the test was repeated for each of ten Locomotive Operational States (Engine Off, Idle, and Notches 1 through 8). The limitations of the test do not permit reliable BER measurements for brief conditions such as Startup Sequence and Shutdown Sequence, so these two locomotive operational states were not tested.

The worse-case level observed for a reliable BER of E-4 was -103 dBm.

The following table shows the observed minimum signal levels required to sustain a BER of E-4 for the Baseline, and for the ten Locomotive Operational States.

TABLE E BER Test Results

Locomotive State	BER E-4 Level
Radio Isolated	-113
Off	-105
Idle	-103
Notch 1	-103
Notch 2	-103
Notch 3	-103
Notch 4	-103
Notch 5	-103
Notch 6	-103
Notch 7	-103
Notch 8	-103

Summary:

Mechanical items:

Some damage was noted on the antennas located on the rear section of the locomotive. The VHF antenna appeared to have been struck and bent at the base (see figure 36 below), this would not appear to affect operations in due to the fact that this antenna was not used with any active transmission system. The UHF antenna also in the rear roof section was loose on inspection and did not have sufficient electrical ground to be functional (see figure 37 below).



Damaged VHF antenna
Figure 36



Loose UHF HOT Antenna
Figure 37

VSWR:

The VSWR of the low profile Sinclair Technologies Inc. VHF antenna model number EXCAL221-8952446 was compliant with the manufacturers published specifications and no significant mismatch was noted. The 220 PTC antenna manufactured by Sinclair Technologies Inc. model number ST221-SF3SNF has a published frequency range of 217-223 MHz with a maximum specification of 1.5:1. Within this range the antenna was not compliant as tested at the end of the cable that would connector to the transceiver equipment. The vendor requirements for the ground plane of this antenna are a 36" by 36" metal plane. The surface area around the antenna is compliant. One possible reason for the mismatch may be the placement of the VHF antenna in the near field of the 220 MHz antenna (see figure 38). The spacing between the antennas is approximately 11 inches.

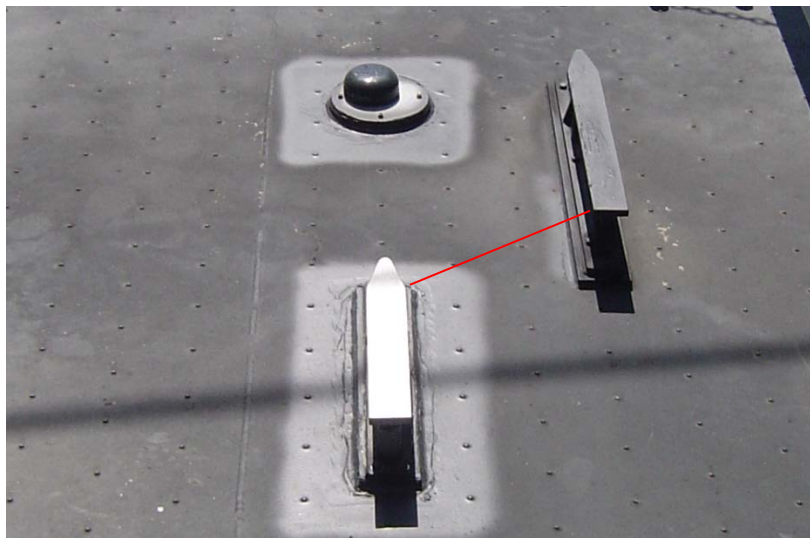

220 PTC Antenna and VHF Antenna
Figure 38

The VSWR reflection data on the Sinclair UHF antenna was taken after the unit was tightened down and indicated that the unit was functioning correctly.

The cellular antenna response for both cell antennas were in spec for a 820-960 MHz bandwidth <2:1. There were some variations in the response, but these may be attributed to the proximity of the fall protection and can be dis-regarded. These antennas were not rated for PCS band response but the data is presented in this report as a matter of reference.

The 802.11 antenna did not pass the manufacturer specification. After some investigation with the manufacturer it was determined that this antenna is in fact a cellular style MLPV-698 with a rated frequency range 806-960.

The antenna is connected to the OBN 802.11 W1 port. According to the manufacturer the radio in WMIC1 is an 802.11b radio and only supports the 2.4GHz range with allowed frequencies of:

- 2412(1)
- 2417(2)
- 2422(3)
- 2427(4)
- 2432(5)
- 2437(6)
- 2442(7)
- 2447(8)
- 2452(9)
- 2457(10)
- 2462(11)



Center antenna is designated as 802.11
According to physical height >3" it can only be in the cellular range MLPV-698
Figure 38

It is recommended that this antenna be replaced with the correct model PCTEL MLPV1700 (1700-2700 MHz 1000 MHz 4 dBi) or similar to improve performance.

Insertion Loss:

While testing the insertion loss of the cables it was determined that one of the cellular cables was measuring a high loss in the band. Upon inspection a loose ground between the connector body and the cable shield was found near the equipment room end of the cable. The cable was repaired and testing resumed all data taken was after the repair was accomplished.

Antenna Isolation:

The antenna isolation was recorded for each of the antennas on board. Since this customer currently has no plans on adding filtering to any of the antenna systems, filtered data was not taken. The isolation data is provided for reference and was used for troubleshooting potential problems identified by intermodulation testing. The worst case isolation was measured to be between the VHF antenna and the 220 MHz PTC antenna at approximately 25 decibels. Although this Locomotive is not currently equipped with Distributed Power, filters must be considered should those radios be installed in the future. (See report for CSX 985).

Receive Intermodulation:

The receiver intermodulation test revealed a small spur near 221 MHz being generated in the HOT/EOT Receiver when the AAR VHF Voice Radio is keyed. Filtering of all significant contributor radios is emphatically recommended.

Transmit Intermodulation Testing:

Several energy events were noted during the Transmit Intermodulation test with the HOT/EOT radio and the AAR VHF Voice Radio. Significant Intermodulation Products were generated by off-platform FM Broadcast signals mixing in the Power Amplifier stage of the AAR VHF Voice Radio. Mitigation will require deep FM Broadcast Rejection (notch filtering), probably on the order of 70 dB. More aggressive and controlled testing is recommended. Filtering of all significant contributor radios is emphatically recommended.

EMI testing:

Electromechanically generated power plant noise during the twelve Locomotive Operational States (Engine Off, Startup Sequence, Idle, Notches 1 through 8, and Shutdown Sequence) were about as expected.

BER Testing:

Since the EMI Noise is an on-platform phenomenon, any EMI produced travels with the PTC Radio Receivers. The testing, to date, has established a worse case noise number of 10 dB, and this should be accounted for in the PTC Locomotive Radio Receive Path Link Budget.