



U.S. Department of
Transportation

**Federal Railroad
Administration**

Crippling Load Test of Budd Pioneer Car 244, Test 3

Office of Research
and Development
Washington, DC 20590



NOTICE

This document is disseminated under the sponsorship of the Department of Transportation in the interest of information exchange. The United States Government assumes no liability for its contents or use thereof. Any opinions, findings and conclusions, or recommendations expressed in this material do not necessarily reflect the views or policies of the United States Government, nor does mention of trade names, commercial products, or organizations imply endorsement by the United States Government. The United States Government assumes no liability for the content or use of the material contained in this document.

NOTICE

The United States Government does not endorse products or manufacturers. Trade or manufacturers' names appear herein solely because they are considered essential to the objective of this report.

REPORT DOCUMENTATION PAGE*Form Approved
OMB No. 0704-0188*

Public reporting burden for this collection of information is estimated to average 1 hour per response, including the time for reviewing instructions, searching existing data sources, gathering and maintaining the data needed, and completing and reviewing the collection of information. Send comments regarding this burden estimate or any other aspect of this collection of information, including suggestions for reducing this burden, to Washington Headquarters Services, Directorate for Information Operations and Reports, 1215 Jefferson Davis Highway, Suite 1204, Arlington, VA 22202-4302, and to the Office of Management and Budget, Paperwork Reduction Project (0704-0188), Washington, DC 20503.

1. AGENCY USE ONLY (Leave blank)		2. REPORT DATE April 2013	3. REPORT TYPE AND DATES COVERED Technical Report	
4. TITLE AND SUBTITLE Crippling Load Test of Budd Pioneer Car 244, Test 3			5. FUNDING NUMBERS DTRF53-00-C-00012 Task Order 235	
6. AUTHOR(S) and FRA COTR Satima Anankitpaiboon, Robert Fries, and Lucy Tunna				
7. PERFORMING ORGANIZATION NAME(S) AND ADDRESS(ES) Transportation Technology Center, Inc. 55500 DOT Road Pueblo, CO 81001			8. PERFORMING ORGANIZATION REPORT NUMBER	
9. SPONSORING/MONITORING AGENCY NAME(S) AND ADDRESS(ES) U.S. Department of Transportation Federal Railroad Administration Office of Research and Development 1200 New Jersey Avenue, SE Washington, DC 20590			10. SPONSORING/MONITORING AGENCY REPORT NUMBER DOT/FRA/ORD-13/23	
11. SUPPLEMENTARY NOTES Program Manager: Jeff Gordon				
12a. DISTRIBUTION/AVAILABILITY STATEMENT This document is available to the public through the FRA Web site at http://www.fra.dot.gov .			12b. DISTRIBUTION CODE	
13. ABSTRACT (Maximum 200 words) This report summarizes Test 3, a crippling load test on Budd Pioneer Car 244, conducted on June 28, 2011. Before the crippling load test, Transportation Technology Center, Inc., conducted two 800,000-pound (lb) quasi-static tests on Car 244 in accordance with Code of Federal Regulations 49 CFR 239.203. The tests, which are summarized in this report, applied compressive end loads along the line of draft to ensure that Car 244 was suitable for the crippling load test. Car 244 was previously modified to include a crash energy management (CEM) system, and it was subjected to several impact tests. For the crippling load test, the CEM system was removed. Loads were applied at the four CEM pockets on one end of the car and reacted at the CEM pockets on the other end. Crippling first occurred on the roof at approximately 1,070,000 lb, and complete car crippling occurred at approximately 1,200,000 lb. Crippling occurred on the side sills, center sill, side walls, and roof near the loading end. The total car length after the test was reduced by approximately 3 inches. The instrumentation for this test measured car strains, displacements, and compressive forces.				
14. SUBJECT TERMS Passenger car, compressive load test, crippling			15. NUMBER OF PAGES 33	
			16. PRICE CODE	
17. SECURITY CLASSIFICATION OF REPORT Unclassified	18. SECURITY CLASSIFICATION OF THIS PAGE Unclassified	19. SECURITY CLASSIFICATION OF ABSTRACT Unclassified	20. LIMITATION OF ABSTRACT	

METRIC/ENGLISH CONVERSION FACTORS

ENGLISH TO METRIC

METRIC TO ENGLISH

<p>LENGTH (APPROXIMATE)</p> <p>1 inch (in) = 2.5 centimeters (cm) 1 foot (ft) = 30 centimeters (cm) 1 yard (yd) = 0.9 meter (m) 1 mile (mi) = 1.6 kilometers (km)</p>	<p>LENGTH (APPROXIMATE)</p> <p>1 millimeter (mm) = 0.04 inch (in) 1 centimeter (cm) = 0.4 inch (in) 1 meter (m) = 3.3 feet (ft) 1 meter (m) = 1.1 yards (yd) 1 kilometer (km) = 0.6 mile (mi)</p>
<p>AREA (APPROXIMATE)</p> <p>1 square inch (sq in, in²) = 6.5 square centimeters (cm²) 1 square foot (sq ft, ft²) = 0.09 square meter (m²) 1 square yard (sq yd, yd²) = 0.8 square meter (m²) 1 square mile (sq mi, mi²) = 2.6 square kilometers (km²) 1 acre = 0.4 hectare (he) = 4,000 square meters (m²)</p>	<p>AREA (APPROXIMATE)</p> <p>1 square centimeter (cm²) = 0.16 square inch (sq in, in²) 1 square meter (m²) = 1.2 square yards (sq yd, yd²) 1 square kilometer (km²) = 0.4 square mile (sq mi, mi²) 10,000 square meters (m²) = 1 hectare (ha) = 2.5 acres</p>
<p>MASS - WEIGHT (APPROXIMATE)</p> <p>1 ounce (oz) = 28 grams (gm) 1 pound (lb) = 0.45 kilogram (kg) 1 short ton = 2,000 pounds (lb) = 0.9 tonne (t)</p>	<p>MASS - WEIGHT (APPROXIMATE)</p> <p>1 gram (gm) = 0.036 ounce (oz) 1 kilogram (kg) = 2.2 pounds (lb) 1 tonne (t) = 1,000 kilograms (kg) = 1.1 short tons</p>
<p>VOLUME (APPROXIMATE)</p> <p>1 teaspoon (tsp) = 5 milliliters (ml) 1 tablespoon (tbsp) = 15 milliliters (ml) 1 fluid ounce (fl oz) = 30 milliliters (ml) 1 cup (c) = 0.24 liter (l) 1 pint (pt) = 0.47 liter (l) 1 quart (qt) = 0.96 liter (l) 1 gallon (gal) = 3.8 liters (l) 1 cubic foot (cu ft, ft³) = 0.03 cubic meter (m³) 1 cubic yard (cu yd, yd³) = 0.76 cubic meter (m³)</p>	<p>VOLUME (APPROXIMATE)</p> <p>1 milliliter (ml) = 0.03 fluid ounce (fl oz) 1 liter (l) = 2.1 pints (pt) 1 liter (l) = 1.06 quarts (qt) 1 liter (l) = 0.26 gallon (gal) 1 cubic meter (m³) = 36 cubic feet (cu ft, ft³) 1 cubic meter (m³) = 1.3 cubic yards (cu yd, yd³)</p>
<p>TEMPERATURE (EXACT)</p> <p>$[(x-32)(5/9)] \text{ } ^\circ\text{F} = y \text{ } ^\circ\text{C}$</p>	<p>TEMPERATURE (EXACT)</p> <p>$[(9/5)y + 32] \text{ } ^\circ\text{C} = x \text{ } ^\circ\text{F}$</p>

QUICK INCH - CENTIMETER LENGTH CONVERSION

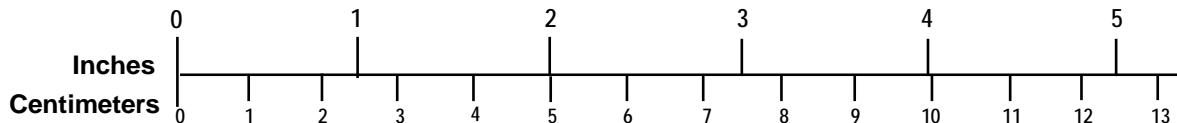

QUICK FAHRENHEIT - CELSIUS TEMPERATURE CONVERSION

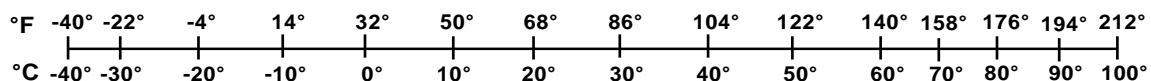

For more exact and or other conversion factors, see NIST Miscellaneous Publication 286, Units of Weights and Measures. Price \$2.50 SD Catalog No. C13 10286

Updated 6/17/98

Contents

Executive Summary	1
1. Introduction	2
1.1 Objectives	2
1.2 Background	2
2. Test Requirements and Method.....	9
3. Instrumentation.....	12
4. Results	16
4.1 Overview	16
4.2 Detailed Results.....	16
5. Conclusions	24
6. References	25
Abbreviations and Acronyms	26

Illustrations

Figure 1. Test Setup for Test 1 – Compressive Load along Line of Draft	3
Figure 2. Line-of-Draft Load Applied at A-End for Test 1	3
Figure 3. Target Load History for Tests 1 and 2.....	4
Figure 4. Two Fatigue Cracks Found in the Right Side Sill after Test 1 on Car 244.....	4
Figure 5. Steel Patch to Repair Fatigue Cracks	5
Figure 6. Steel Patch Welded onto Both Side Sills on Car 244.....	5
Figure 7. Location of the Steel Patch below Window 8 on Car 244	5
Figure 8. Closeup Location of Steel Patch below Window 8 on Car 244	6
Figure 9. Load History for Shakedown Test (Car 248)	7
Figure 10. Crippling of Side Walls (Car 248).....	7
Figure 11. Crippling of Roof (Car 248).....	8
Figure 12. Crippling of Center Sill between Cross-Members 4 and 5 (Car 248).....	8
Figure 13. Car 244 in Test Fixture for Crippling Load Test.....	9
Figure 14. CEM System before Removal for Crippling Load Test.....	9
Figure 15. End View of Load Application Sites.....	10
Figure 16. Plan View of Load Application Sites	10
Figure 17. Test Setup at Reaction End and Loading End.....	10
Figure 18. Target Load History for Crippling Load Test	11
Figure 19. Longitudinal Strain Gages Cross-Section Locations.....	12
Figure 20. Longitudinal Strain Gage Locations for Each Cross-Section.....	12
Figure 21. Location of Strain Gages near Roof Absorber Support.....	13
Figure 22. Location of Strain Gages on PEAM Support Added after Tests 1 and 2	13
Figure 23. String Potentiometer Arrangement.....	14
Figure 24. Loading Actuators and Load Cells at Floor and Roof Levels.....	15
Figure 25. Reaction End Load Cells at Floor and Roof Levels	15
Figure 26. Load History for Test 3 (Car 244).....	16
Figure 27. Car 244 after Test 3	17
Figure 28. Crippling on Roof – Side View	17
Figure 29. Crippling on Roof – Top View.....	18
Figure 30. Crippling on Side Walls	18

Figure 31. Crippling on Side Sills and Walls	19
Figure 32. Kinks on Side Sills	19
Figure 33. Locations of Kinks on Side Sill and Center Sill.....	20
Figure 34. Center Sill Crippling.....	20
Figure 35. Kink on Center Sill under Car Floor	21
Figure 36. Relative Locations of Crippling	21
Figure 37. Load-Deflection Curve.....	22
Figure 38. Compressive Displacement along Car Center Line.....	23

Executive Summary

The Federal Railroad Administration (FRA) has contracted with Transportation Technology Center, Inc. (TTCI), to perform a series of full-scale tests to provide the technical basis for rulemaking that will lead to improved crashworthiness and occupant protection for passenger railroad equipment. The series comprises the following:

1. A quasi-static compressive end-load test at 800,000 pounds (lb), in accordance with Code of Federal Regulations 49 CFR 238.203, using loads applied on the line of draft;
2. A repeat of Test 1 above to determine test vehicle readiness for Test 3. Preexisting fatigue cracks were discovered in Car 244 after Test 1. The fatigue cracks were repaired, and Test 1 was repeated to ensure the integrity of the car. The test vehicle, Budd Pioneer Car 244, was determined to be suitable for Test 3; and
3. A crippling load test to determine the ultimate strength of the car using loads applied through the crash energy management (CEM) system load paths.

This report summarizes Test 3, a crippling load test on Budd Pioneer Car 244 conducted by TTCI on June 28, 2011. Before the crippling load test, TTCI conducted two 800,000-pound quasi-static tests on Car 244 in accordance with 49 CFR 239.203. The tests, which are summarized in this report, applied compressive end loads along the line of draft to ensure that Car 244 was suitable for the final load test.

Car 244 was previously modified to include a CEM system, and it was subjected to several impact tests. For the crippling load test, the CEM system was removed. Loads were applied at the four CEM pockets on one end of the car and reacted at the CEM pockets on the other end.

Crippling first occurred on the roof at approximately 1,070,000 lb, and complete car crippling occurred at approximately 1,200,000 lb. Crippling occurred on the side sills, center sill, side walls, and roof near the loading end. The total car length after the test was reduced by approximately 3 inches (in). The instrumentation for this test measured car strains, displacements, and compressive forces.

1. Introduction

FRA has a continuing program to provide the technical basis for rulemaking that will lead to improved crashworthiness and occupant protection for passenger railroad equipment. The program includes both conventional equipment and innovative equipment that is being introduced more frequently into U.S. service. FRA contracted with TTCI for support of full-scale test planning, test implementation, and processing of test data in support of this program.

The FRA program is currently focused on investigating alternative methods to assess the occupant volume strength of innovative rail cars, many of which contain CEM systems [1]. The test vehicle used in this test program was Budd Pioneer Car 244, which was previously modified to include a CEM system; it was tested in full-scale tests five times before this test program. In the current program, three tests were performed on Car 244.

The series of three tests included the following:

1. Test 1 was an 800,000-pound quasi-static end-load test in accordance with 49 CFR 239.203 using loads applied on the line of draft. This test was conducted January 20, 2010 [2].
2. Test 2 was a repeat of Test 1 after a repair of side sill cracks, and it was conducted January 19, 2011 [3].
3. Test 3 was a crippling load test to determine the ultimate strength of the car using loads applied through the CEM system load paths. This test was conducted June 28, 2011.

Tests 1 and 2 were conducted to provide assurance that the test vehicle was suitable for Test 3. Before Test 3, a shakedown test was performed on Budd Pioneer Car 248 to validate the test fixture and test procedures for a crippling load test. Companion computational work performed by the John A. Volpe National Transportation Systems Center for the three-test series provided predictions of the vehicle's response to the tests, in addition to substantial information that was essential in test planning and preparation [4].

This report reviews Tests 1 and 2 and the shakedown test, and provides details about the crippling load test (Test 3).

1.1 Objectives

The objectives of Test 3 were (1) to determine the ultimate load capacity of Car 244 by applying loads through the CEM system load paths quasi-statically until crippling occurred, and (2) to demonstrate the feasibility of alternative testing methods for nonconventional passenger equipment.

1.2 Background

In January 2010, Test 1 subjected Car 244 to an 800,000-pound quasi-static end-load test using loads applied on the line of draft. Figure 1 shows Car 244 in the test fixture during the test. Figure 2 shows the actuator applying loads along the line of draft. Figure 3 shows the target load history for Tests 1 and 2.



Figure 1. Test Setup for Test 1 – Compressive Load along Line of Draft



Figure 2. Line-of-Draft Load Applied at A-End for Test 1

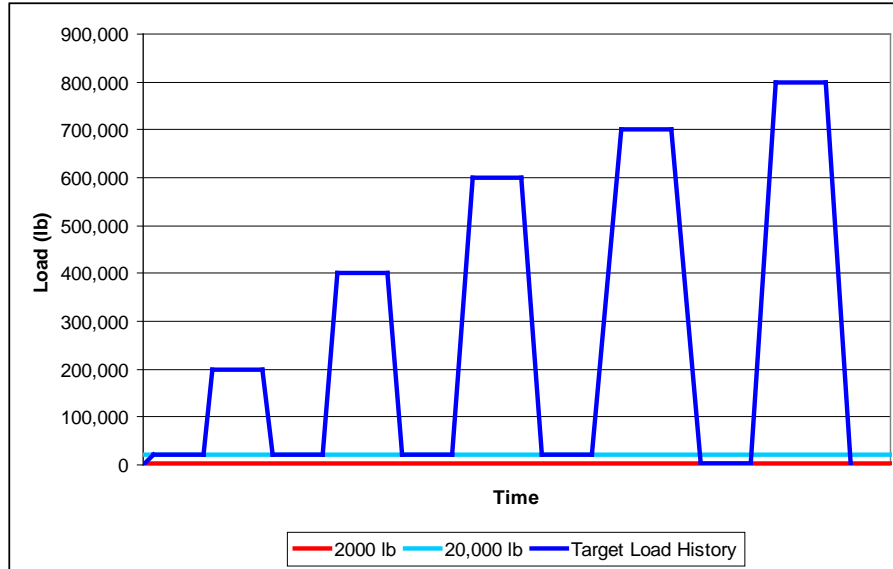

Figure 3. Target Load History for Tests 1 and 2

After Test 1, two fatigue cracks were discovered in the right side sill where brackets had been welded to support undercar equipment (Figure 4). A steel patch (Figure 5) was welded over the cracks to keep the sill side in line during compression for Test 2. Another patch was welded over the left sill to preserve car structural symmetry (Figure 6). Figure 7 and Figure 8 show the locations of the steel patches relative to the car windows. Test 2 was conducted in January 2011. It had the same setup and procedures as Test 1. No significant permanent compression of the car structure occurred after the two tests. Therefore, Car 244 was determined to be suitable for Test 3, the crippling load test.

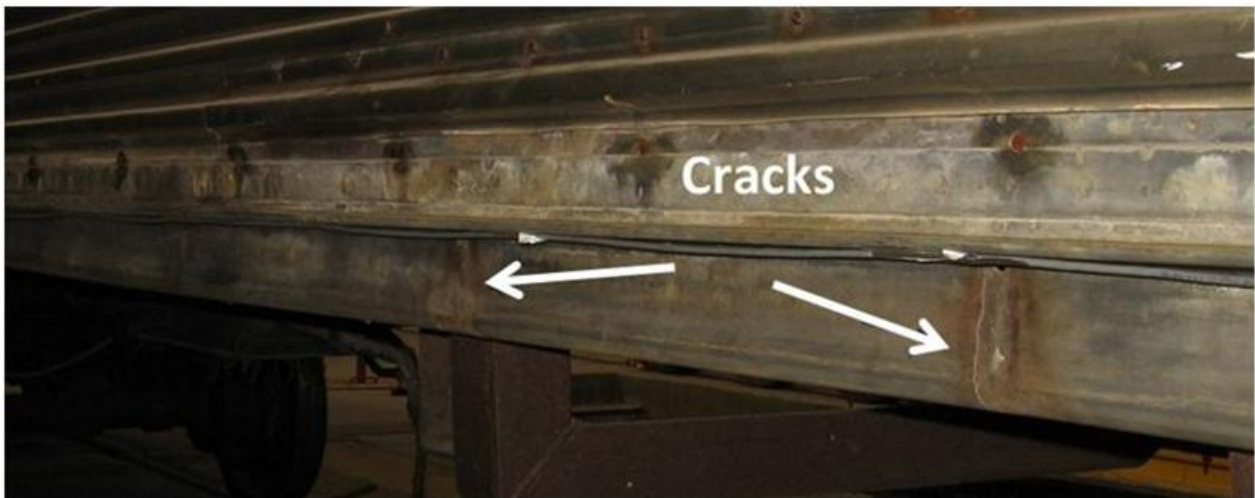

Figure 4. Two Fatigue Cracks Found in the Right Side Sill after Test 1 on Car 244



Figure 5. Steel Patch to Repair Fatigue Cracks



Figure 6. Steel Patch Welded onto Both Side Sills on Car 244



Figure 7. Location of the Steel Patch below Window 8 on Car 244

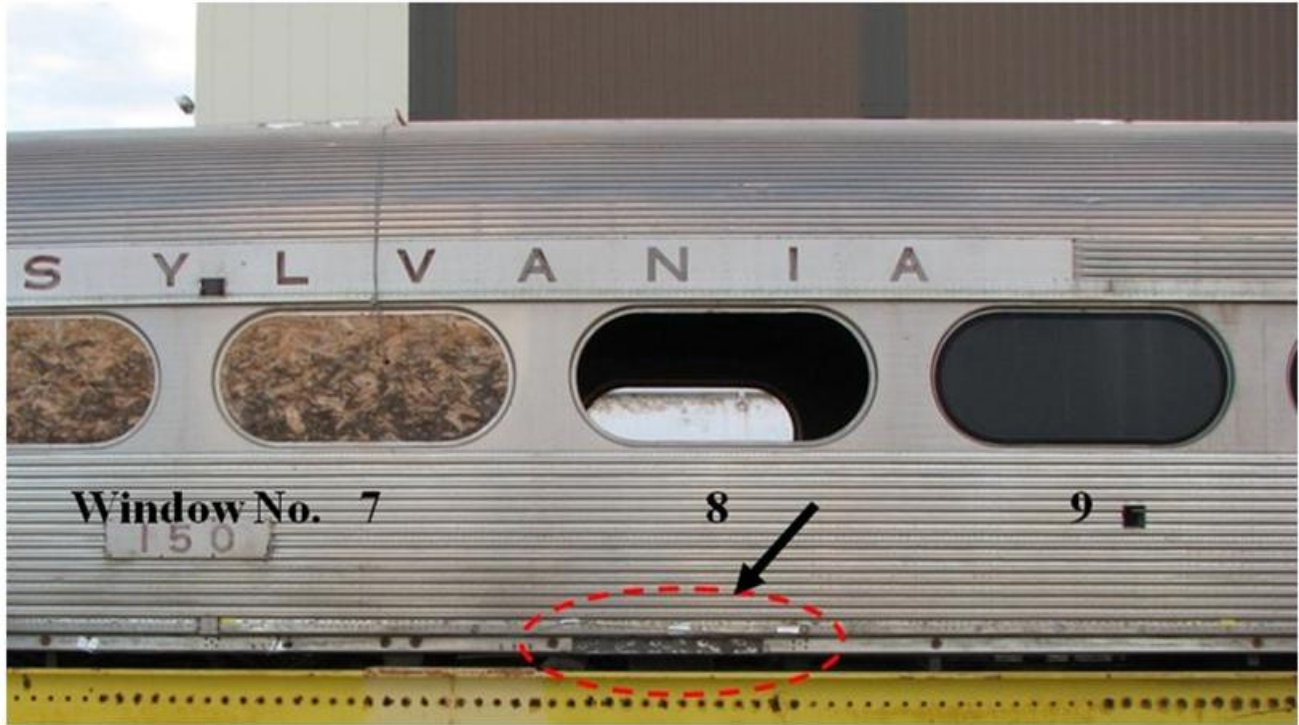

Figure 8. Closeup Location of Steel Patch below Window 8 on Car 244

After Test 2, a shakedown test was performed on Budd Pioneer Car 248 to validate the procedures and loading equipment to be used for the fully instrumented crippling load test of Car 244 (Test 3). Test setup for the shakedown test was similar to Test 3 setup and conduct, but limited instrumentation was used in the shakedown test. The shakedown test was performed successfully; therefore, the new test fixture, equipment, and procedures were determined to be suitable for Test 3.

Figure 9 shows the load history during the shakedown test. The car first crippled at approximately 963,000 lb. The maximum total load applied by the four actuators in the shakedown test was approximately 1,148,000 lb. That load completely crippled the car. Figure 10 through 12 show crippling on Car 248. The crippling on Car 248 occurred between cross-members 4 and 5 in the vicinity of window 8. Unlike Car 244, Car 248 had no side-sill patches below window 8.

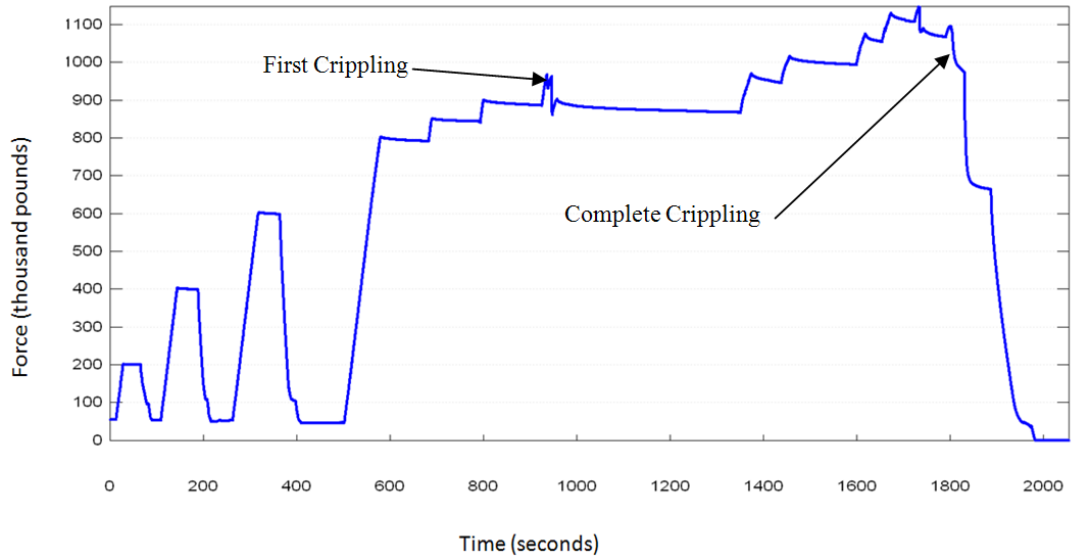

Figure 9. Load History for Shakedown Test (Car 248)

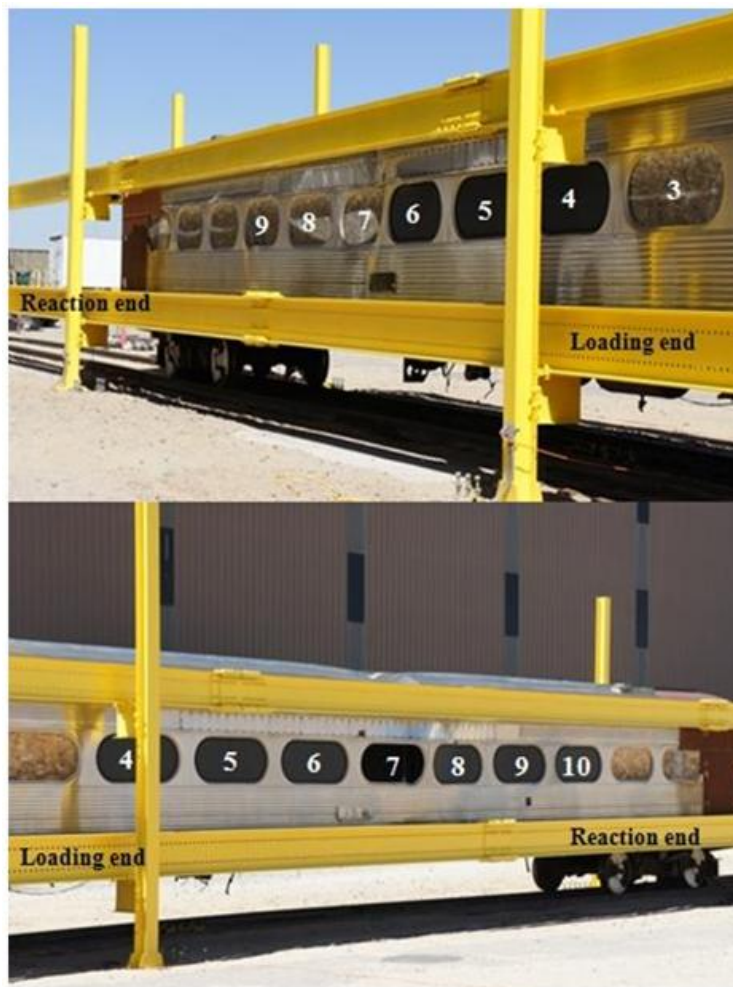

Figure 10. Crippling of Side Walls (Car 248)



Figure 11. Crippling of Roof (Car 248)

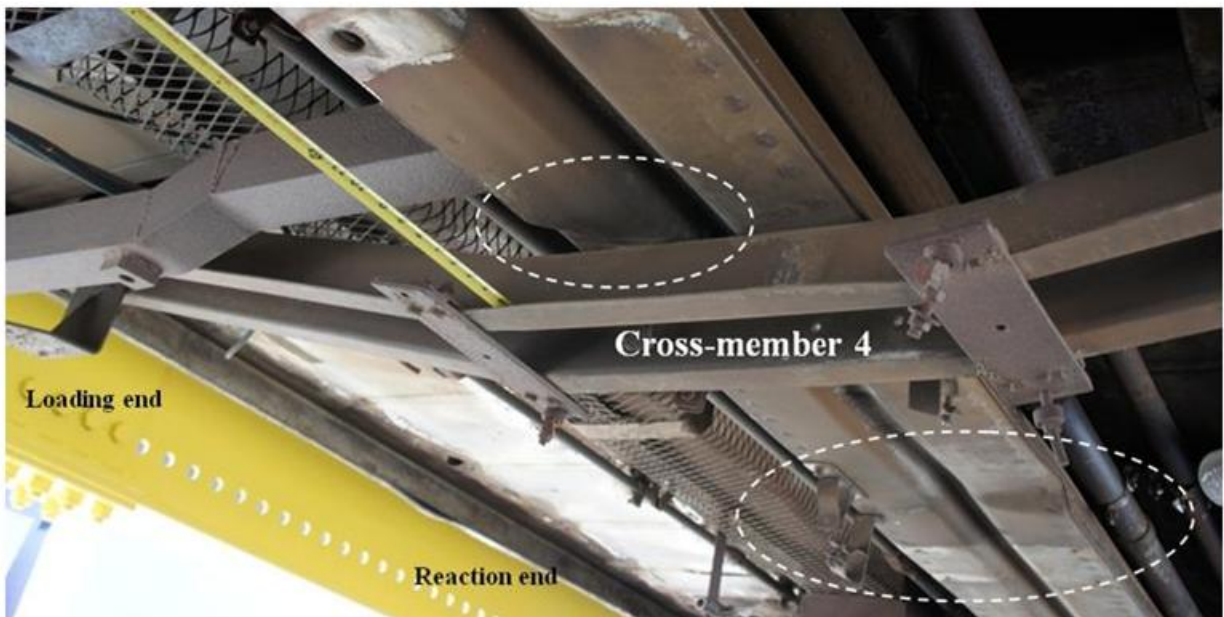

Figure 12. Crippling of Center Sill between Cross-Members 4 and 5 (Car 248)

2. Test Requirements and Method

After Tests 1 and 2 on Car 244 and the Car 248 shakedown test, Car 244 was installed in the full-scale quasi-static compressive load test fixture at the Transportation Technology Center (TTC). Figure 13 shows the test setup for Test 3. The CEM system (Figure 14) was removed from Car 244 for this test. Four actuators at the loading end applied compressive loads through the floor-level and roof-level CEM pockets. Loads were reacted at four CEM pockets at the B-end which were in line with the applied loads (Figure 15 through Figure 17).



Figure 13. Car 244 in Test Fixture for Crippling Load Test



Figure 14. CEM System before Removal for Crippling Load Test

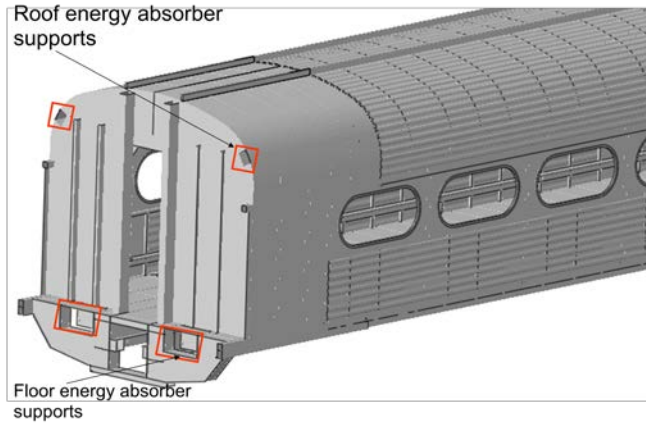

Figure 15. End View of Load Application Sites

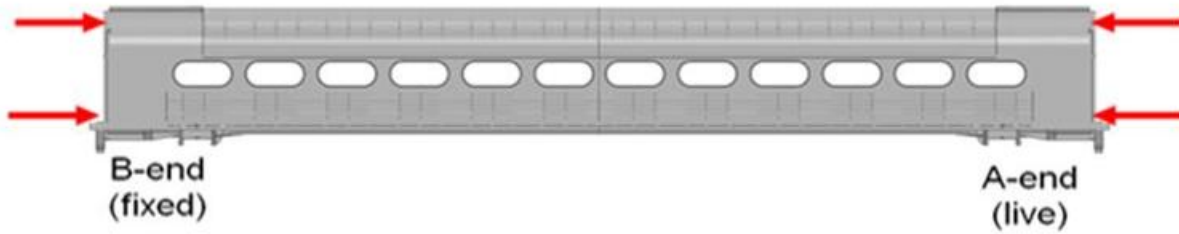

Figure 16. Plan View of Load Application Sites*

*Note: Car was sitting on trucks during testing.



Figure 17. Test Setup at Reaction End and Loading End

Figure 18 shows the target load history for the crippling test. The loads were increased in gradual steps (similar to Tests 1 and 2) according to the test procedure [5]. After a dwell at 800,000 lb, the compressive load was increased in steps until the car could no longer sustain the load.

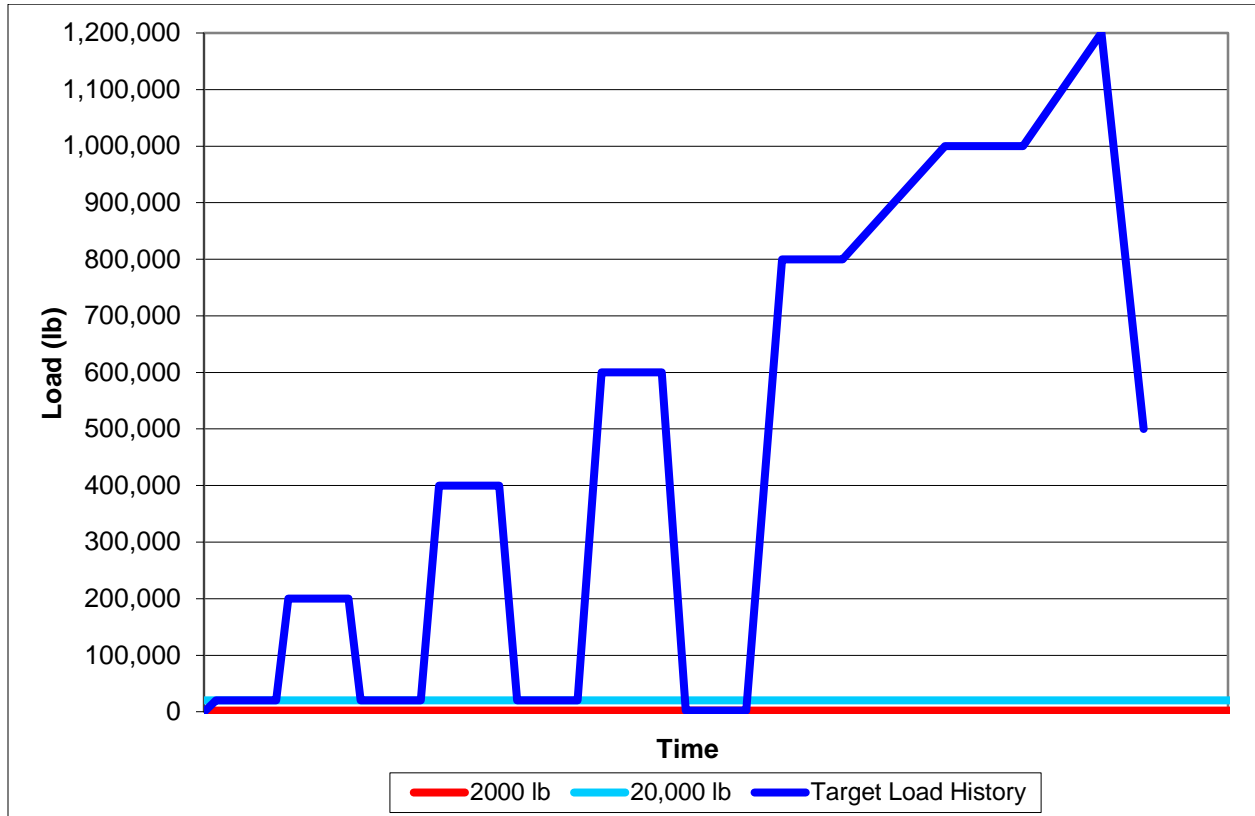

3. Instrumentation

The instrumentation arrangement for Test 3 included 76 strain gages, 41 string potentiometers, and 8 load cells. Figure 19 through Figure 22 show locations of strain gages. Strain gages at locations shown in Figure 21 and Figure 22 were added after Tests 1 and 2. They include gages on the primary energy absorbing mechanism (PEAM) pockets for the CEM system. Figure 23 shows string potentiometer locations. Figure 24 and Figure 25 show load cell locations. The detailed instrumentation arrangement appears in the test implementation plan [5].

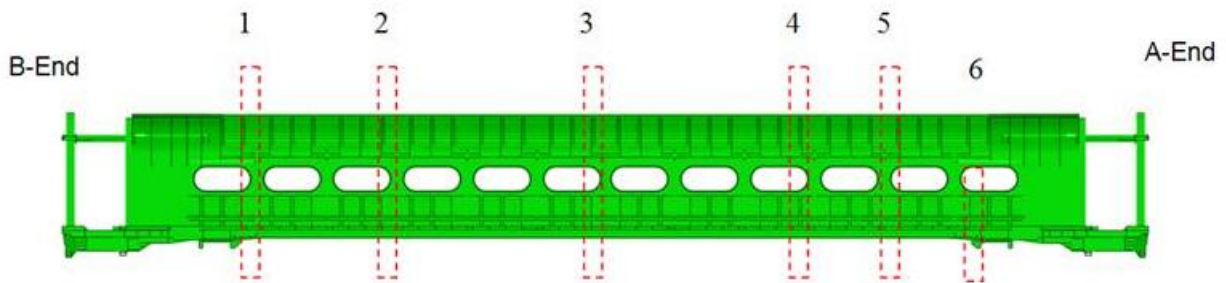

Figure 19. Longitudinal Strain Gages (Cross-Section Locations)

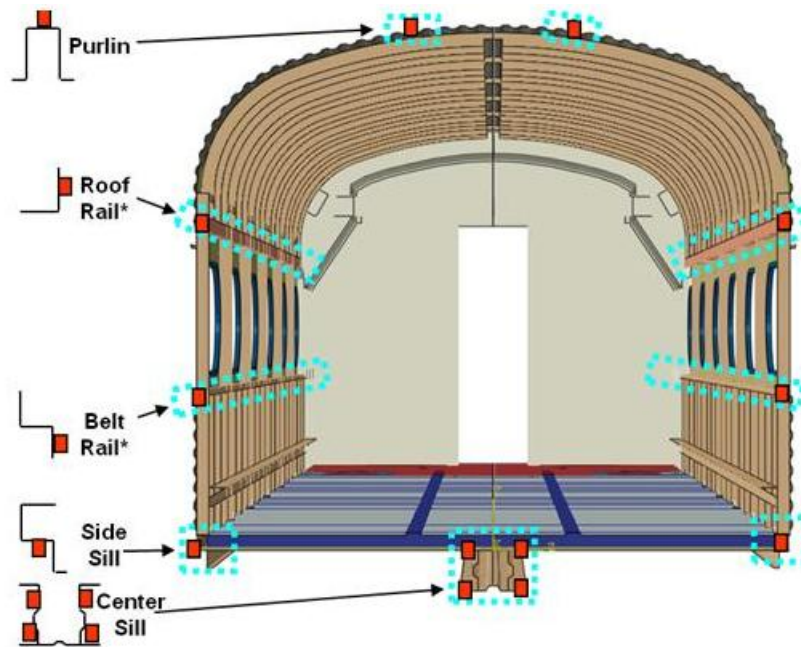

Figure 20. Longitudinal Strain Gage Locations for Each Cross-Section

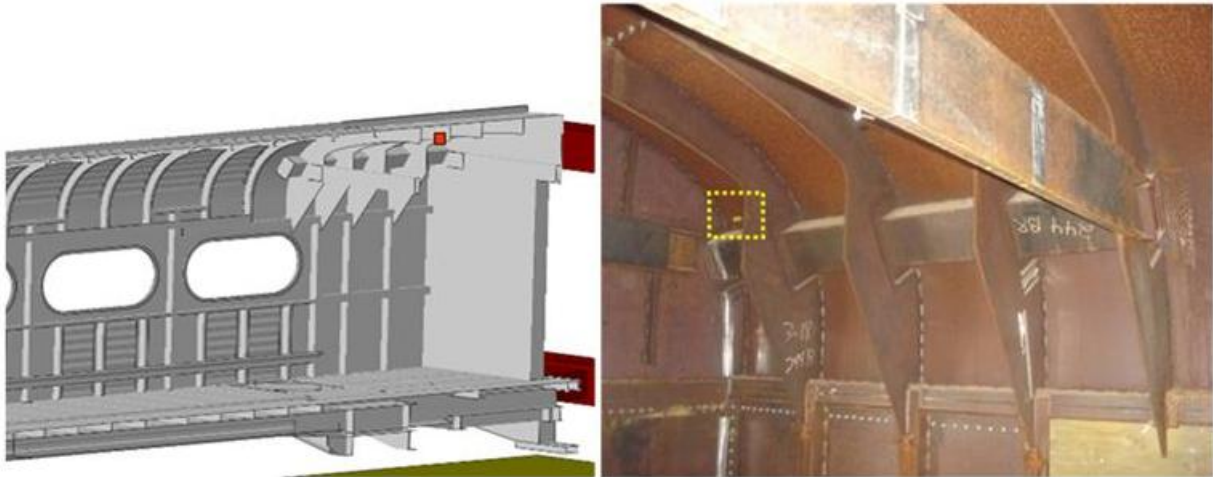

Figure 21. Location of Strain Gages near Roof Absorber Support

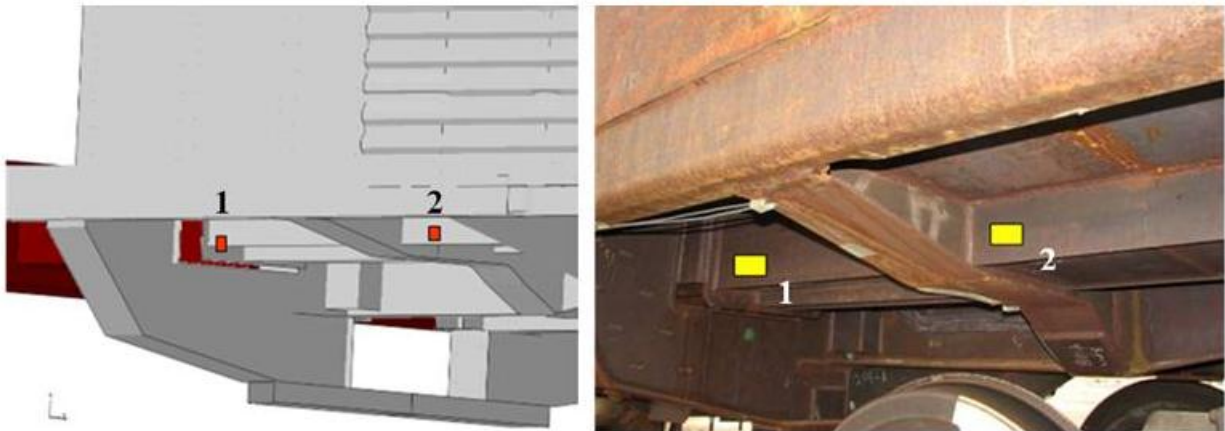

Figure 22. Location of Strain Gages on PEAM Support Added after Tests 1 and 2

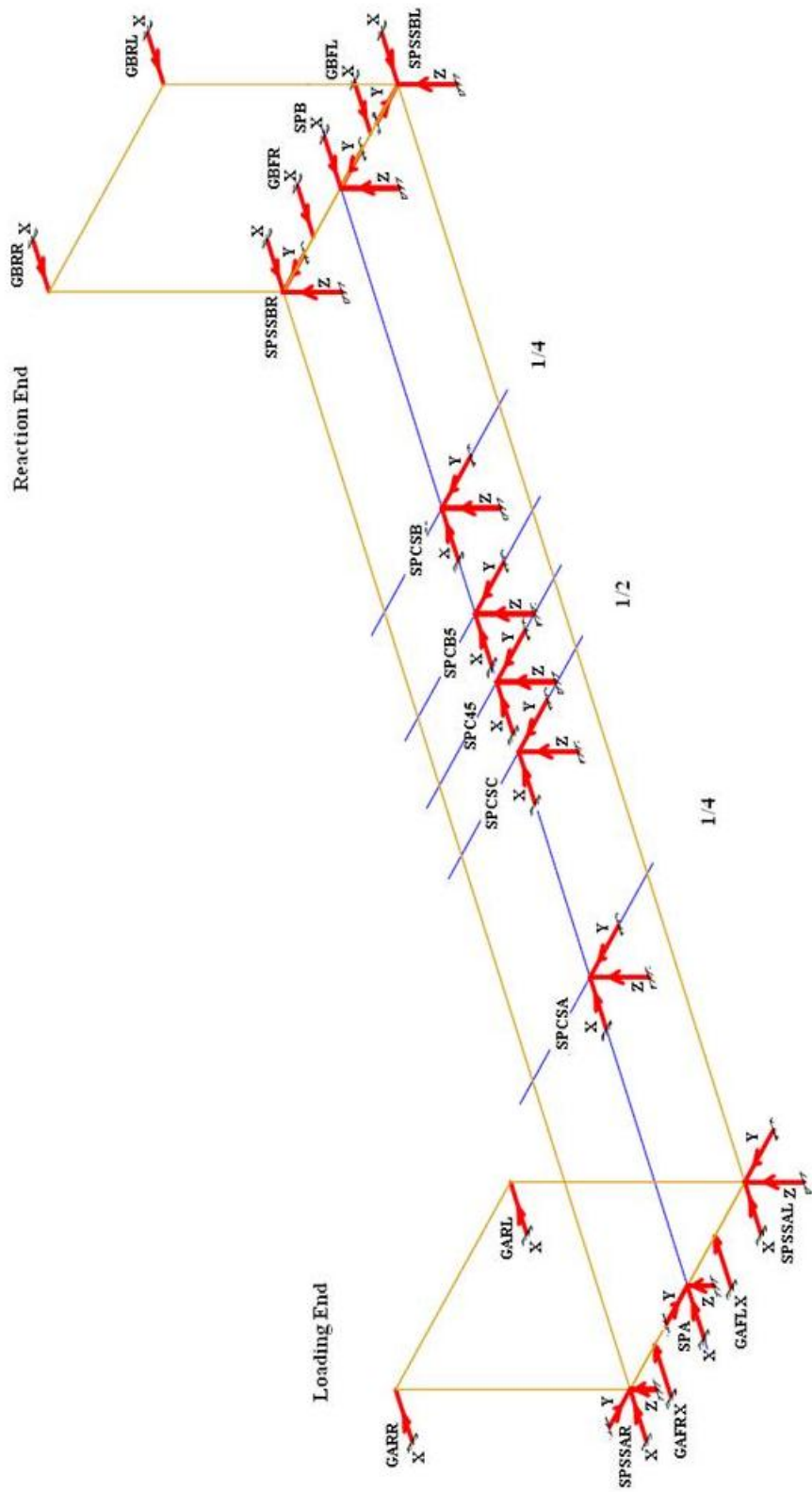

Figure 23. String Potentiometer Arrangement



Figure 24. Loading Actuators and Load Cells at Floor and Roof Levels



Figure 25. Reaction End Load Cells at Floor and Roof Levels

4. Results

4.1 Overview

Car 244 was successfully tested in the upgraded compressive load facility at TTC on June 28, 2011. The upgraded test facility applied four simultaneous loads in synchronous stroke control to the carbody at the CEM pockets.

4.2 Detailed Results

Figure 26 shows the load history for Test 3. It includes the total applied load and each of the four individual actuator loads. Intermediate loading cycles of 200,000, 400,000, and 600,000 lb and the dwell at 800,000 lb were applied in accordance with the test plan [5]. The north side of the car is the left side when viewed from B-end to A-end. The north side roof of Car 244 initially crippld at approximately 1,070,000 lb between cross-members 1 and 2, followed shortly by crippling of the south side roof. The center sill (floor level) failed at approximately 1,200,000 lb between the loading end and cross-member 1.

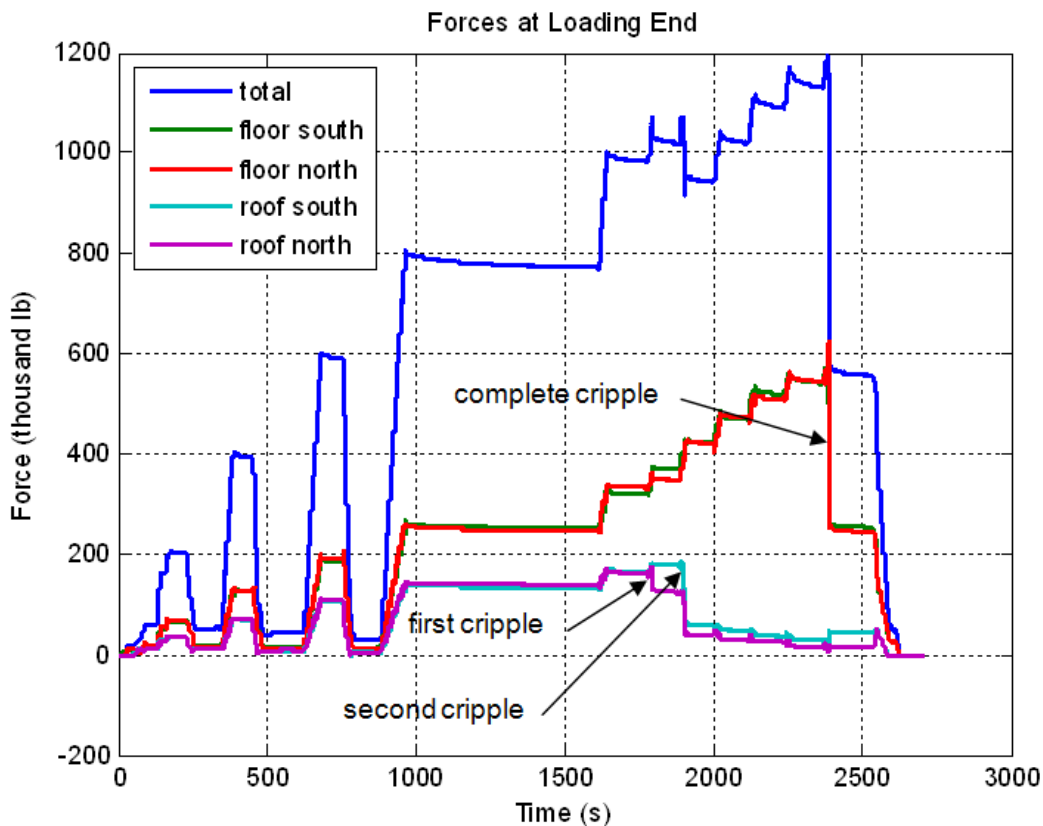

Figure 26. Load History for Test 3 (Car 244)

Figure 27 through Figure 35 show various damage locations after crippling. Figure 36 shows the relative locations of all crippling that occurred under Car 244.

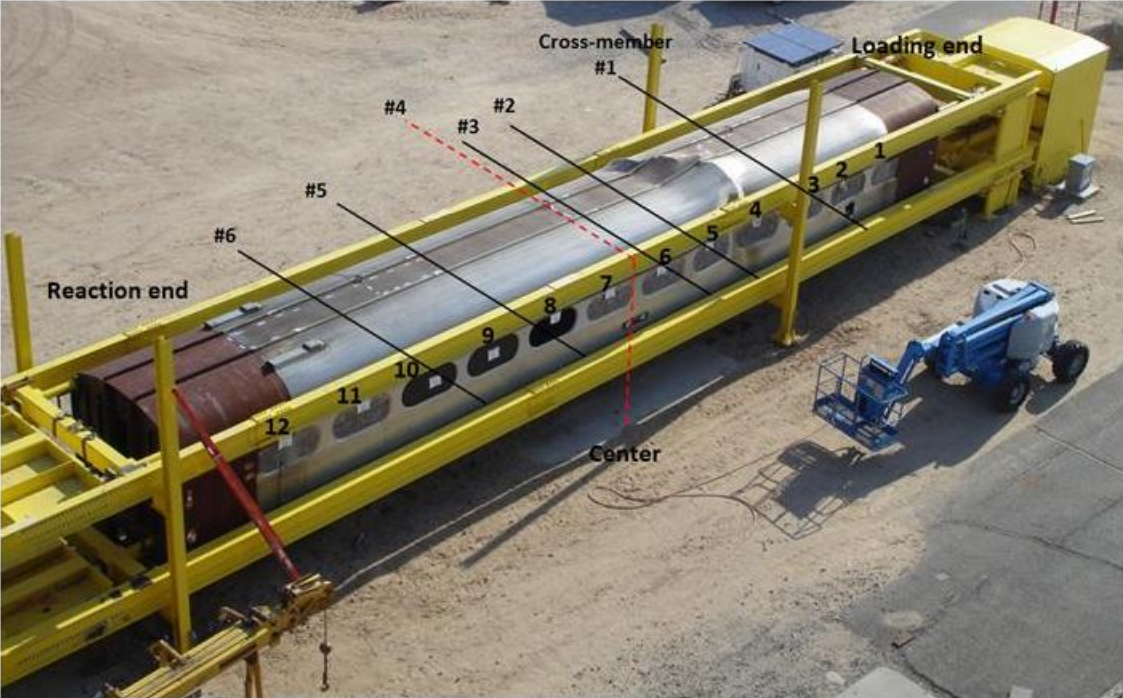

Figure 27. Car 244 after Test 3



Figure 28. Crippling on Roof – Side View

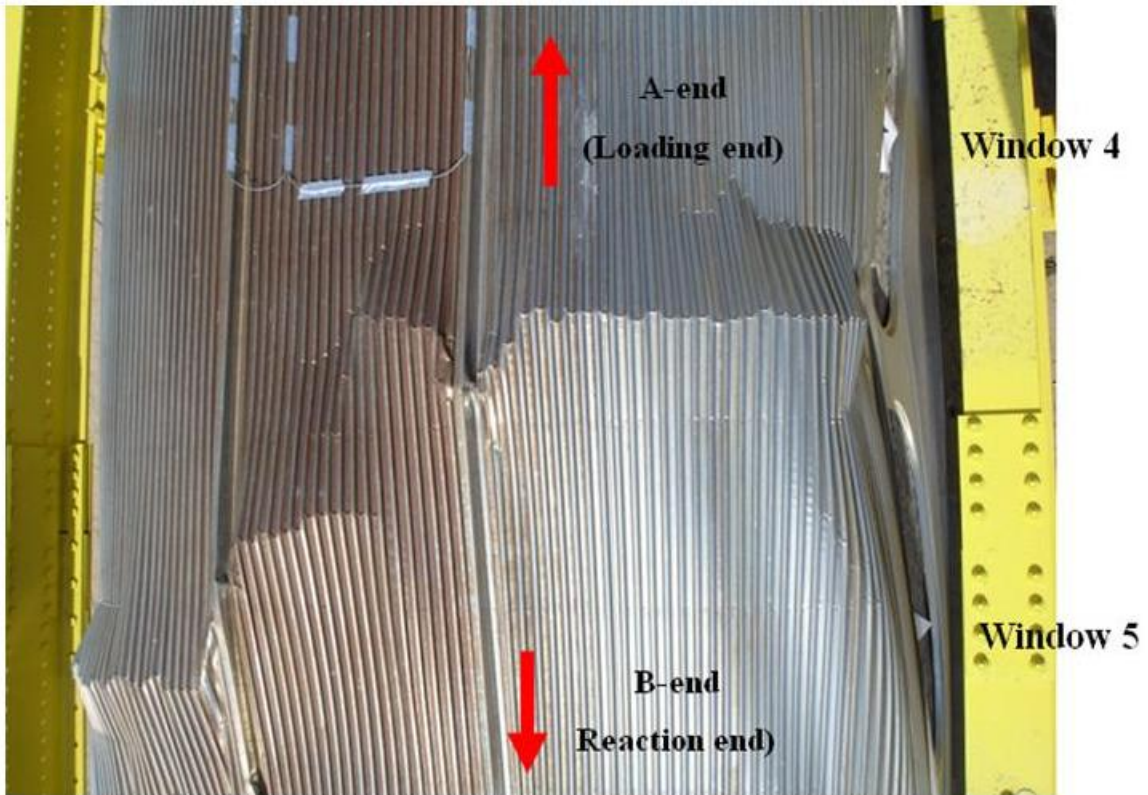

Figure 29. Crippling on Roof – Top View

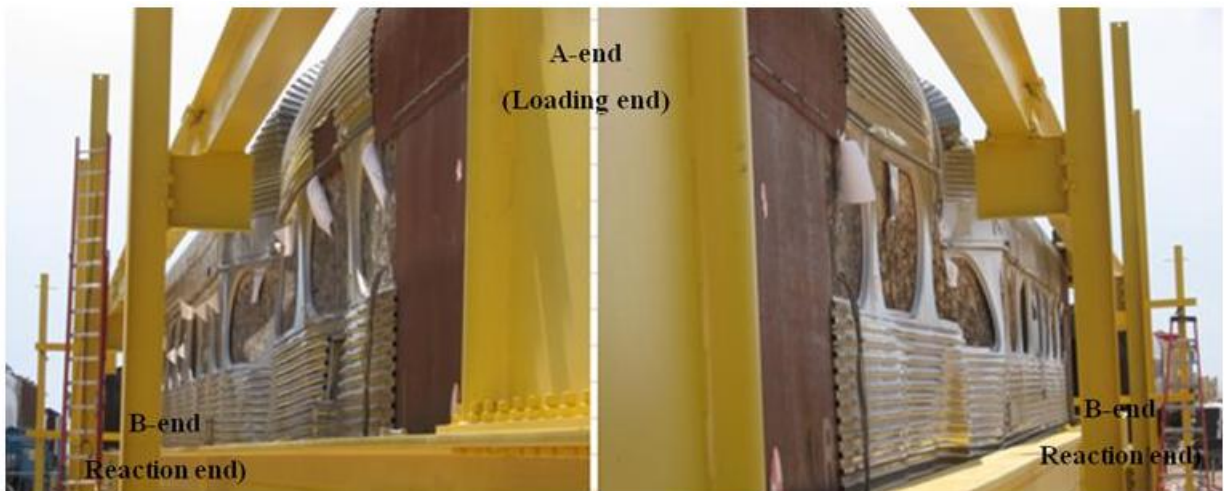

Figure 30. Crippling on Side Walls

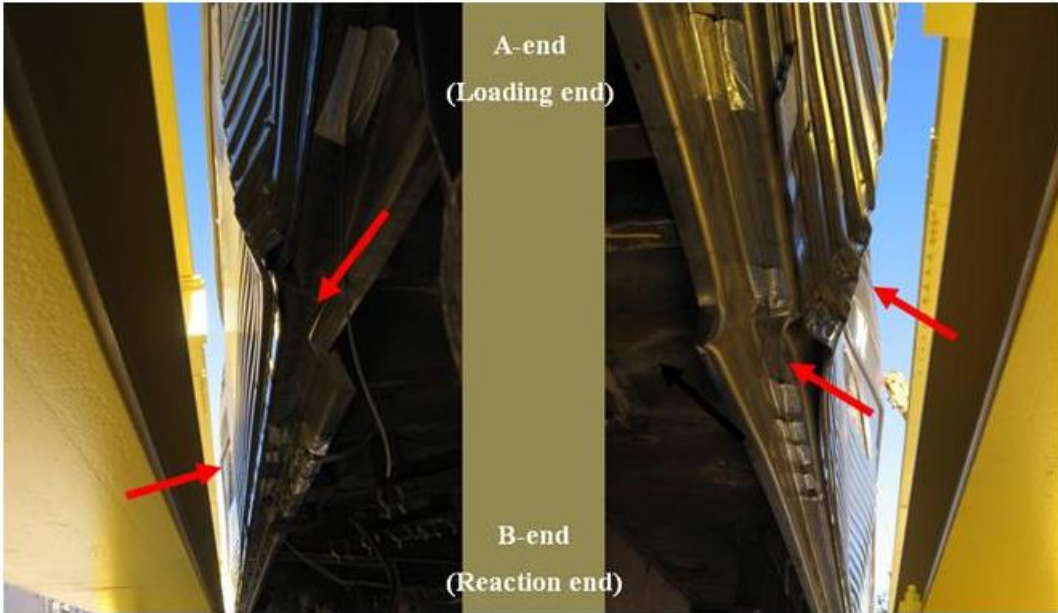

Figure 31. Crippling on Side Sills and Walls

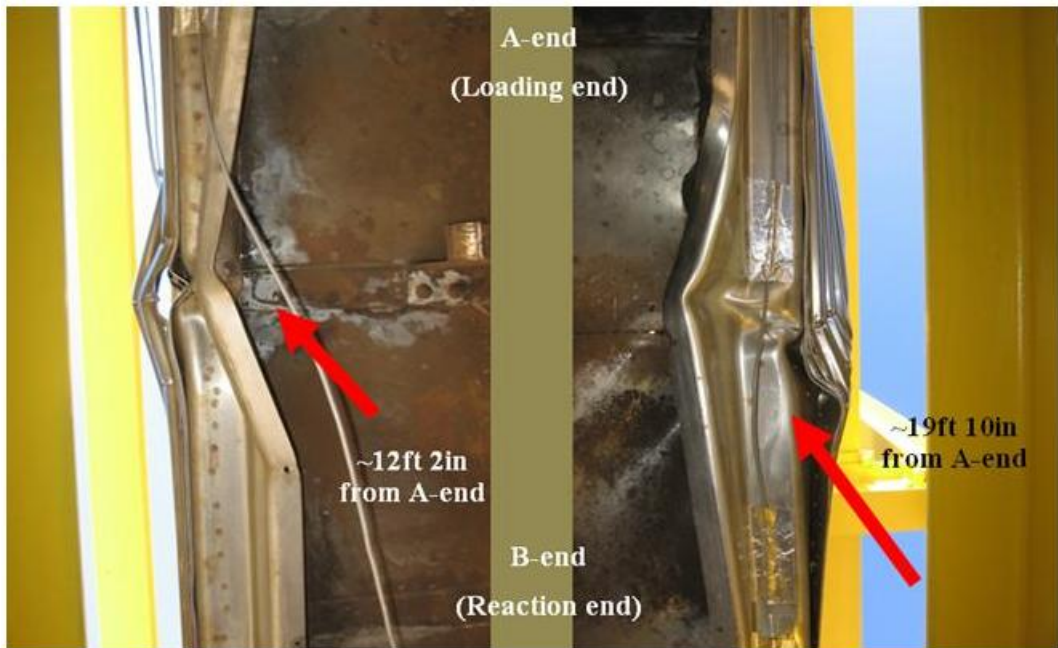

Figure 32. Kinks on Side Sills

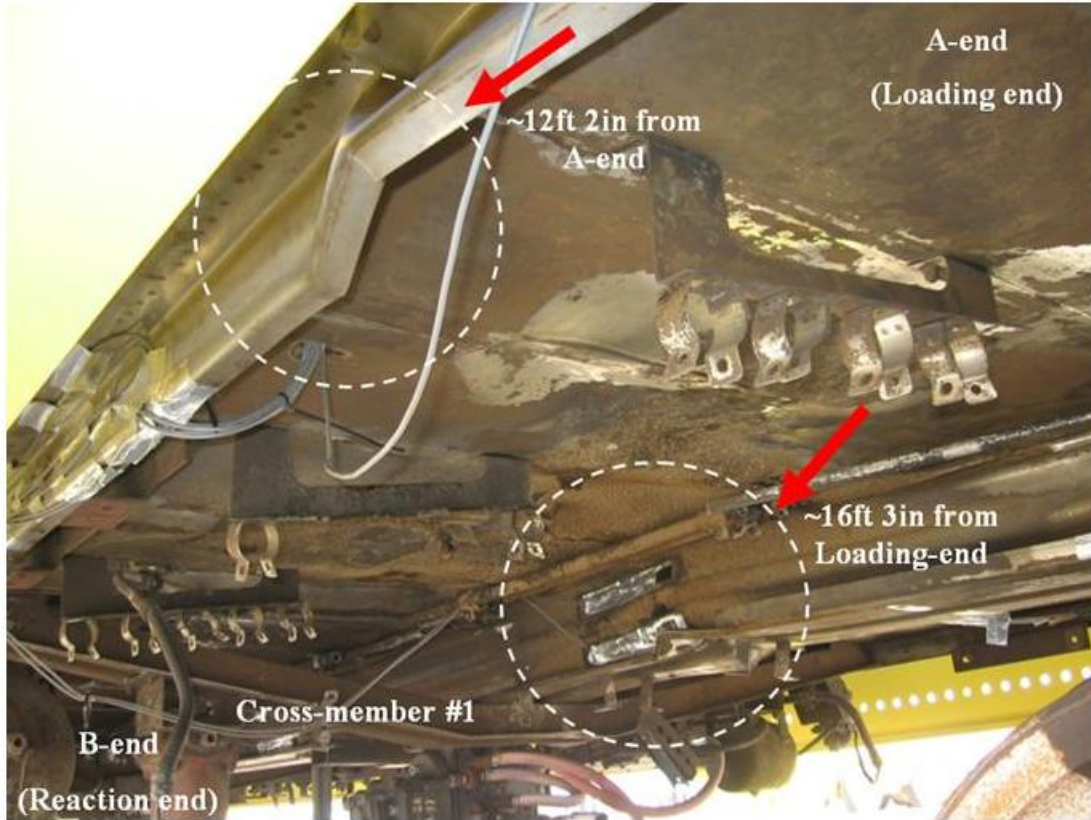

Figure 33. Locations of Kinks on Side Sill and Center Sill



Figure 34. Center Sill Crippling

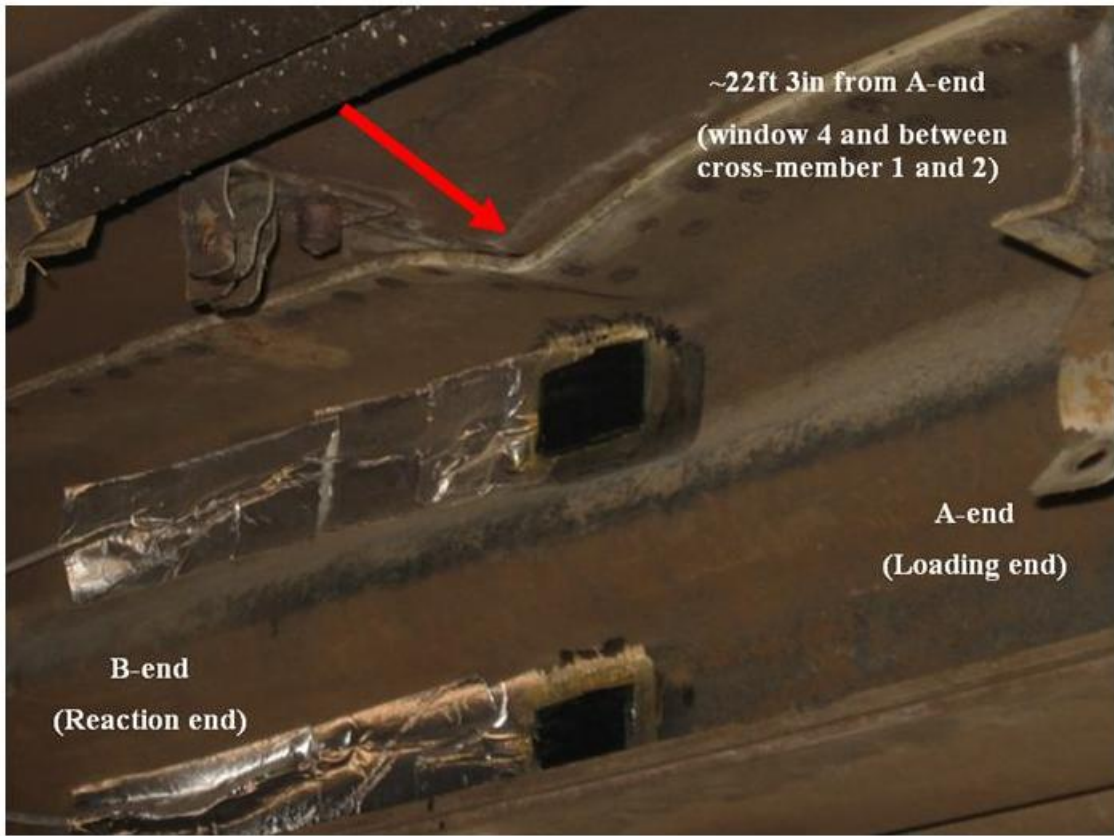

Figure 35. Kink on Center Sill under Car Floor



Figure 36. Relative Locations of Crippling

Figure 37 shows the load-deflection history for Test 3 on Car 244, including the 200,000-, 400,000-, and 600,000-pound load cycles, the dwell at 800,000 lb, and the crippling. The first crippling at the roof level occurred at approximately 1,070,000 lb. The complete crippling, including the center sill and side sills, occurred at approximately 1,200,000 lb.

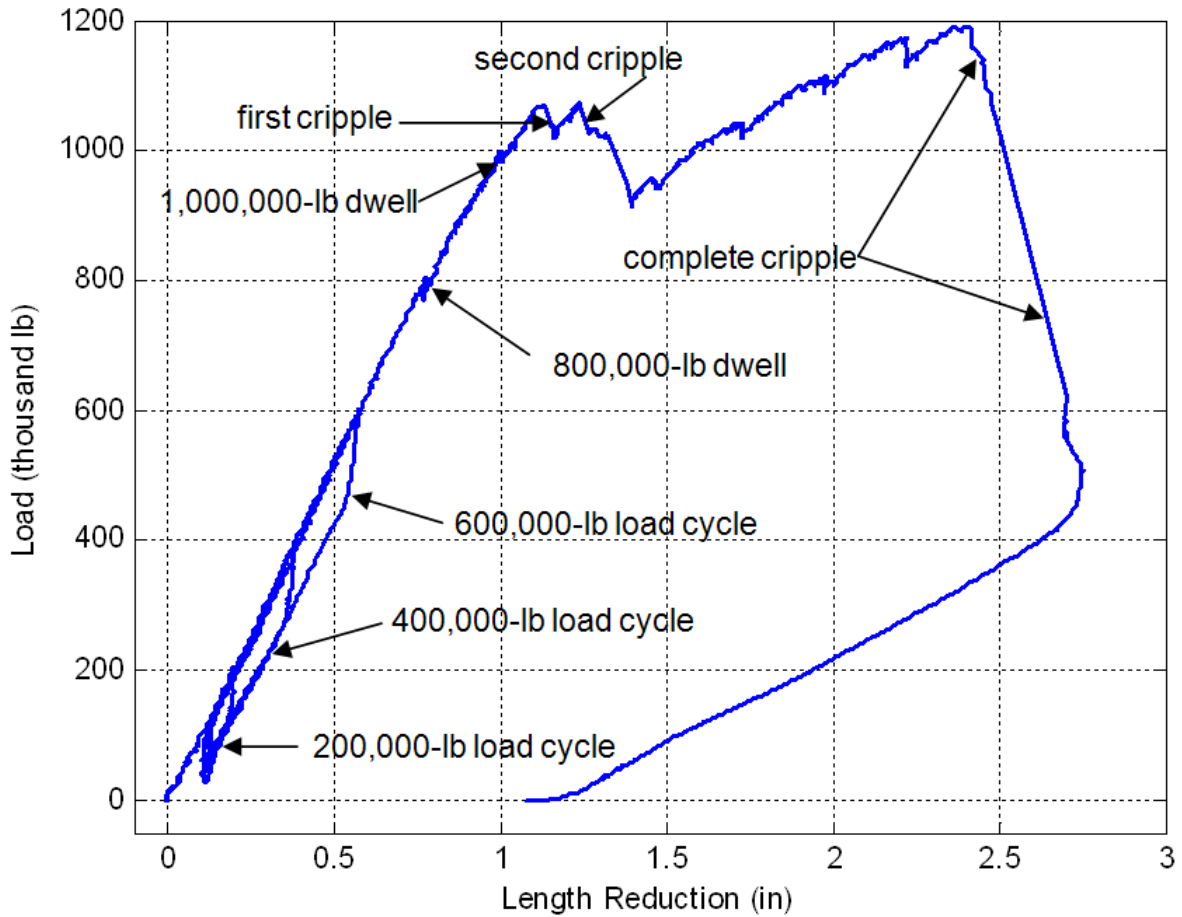
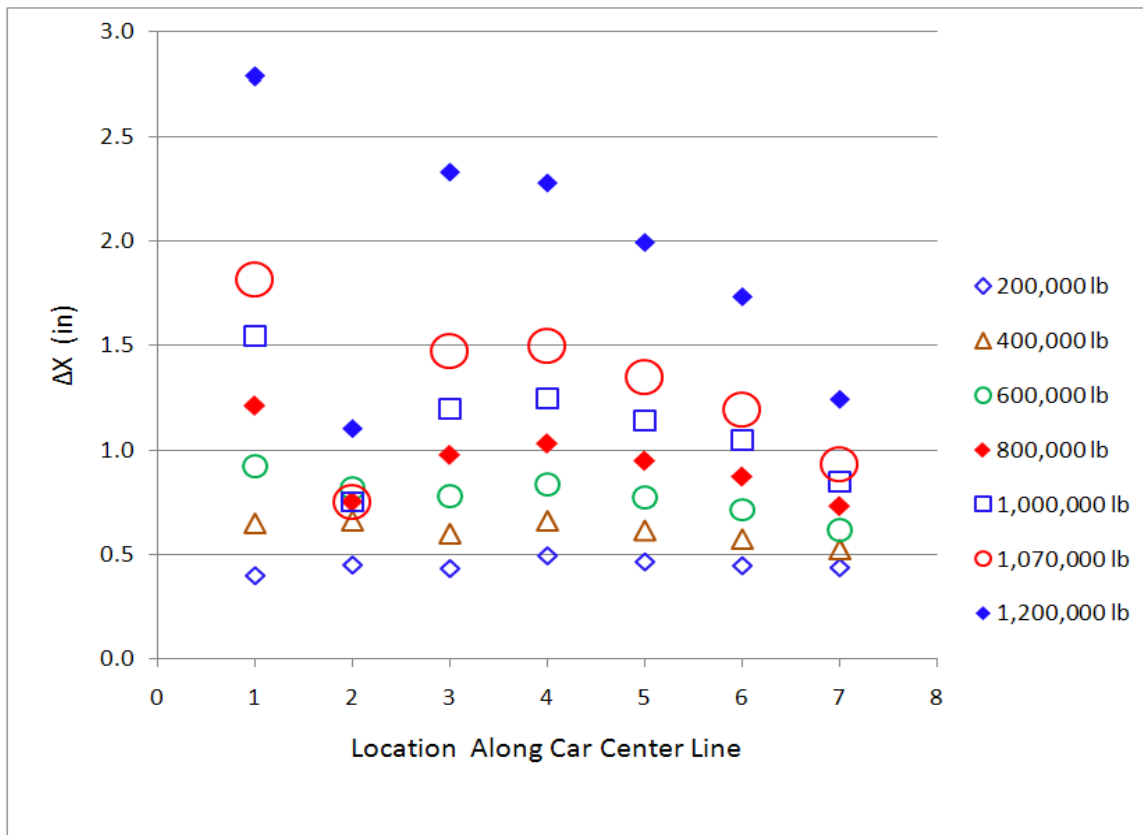

Figure 37. Load-Deflection Curve

Figure 38 shows longitudinal movement of several locations on the center sill relative to the ground. The cross-sections where the measuring string potentiometers were located beneath the car are shown in Figure 19. Location 1 is at the loading end, and location 7 is at the reaction end. The center sill at location 2 stopped moving longitudinally relative to the ground at 800,000 lb, whereas the other locations along the center sill continued to move at higher loads. This indicates that under compressive loads Car 244 crippled in close proximity to location 2. Had these measurements been displayed in real time during the test, they could have provided an indication of the major crippling location even before the 800,000-pound load level was reached. The crippling location shown by the test data in Figure 38 contains the physical damage shown in Figure 33 and Figure 34.



Locations	Description
1	A-end (loading end)
2	1/4 of car length from A-end (cross-member 1)
3	1/2 of car length from A-end (cross-member 4)
4	Between cross-member 4 and 5
5	Cross-member 5
6	1/4 of car length from B-end (cross-member 6)
7	B-end (reaction end)

Figure 38. Compressive Displacement along Car Center Line

5. Conclusions

Test 3 on Budd Pioneer Car 244 was a crippling load test to determine the car's ultimate quasi-static load capacity, which was determined to be approximately 1,200,000 lb. Crippling first occurred on the roof at approximately 1,070,000 lb, and complete car crippling occurred at approximately 1,200,000 lb. Crippling occurred on the side sills, center sill, side walls, and roof near the loading end. The total car length was reduced by approximately 3 in after the test.

Car 244 was previously modified to include a CEM system, and it was subjected to several impact tests. For the crippling load test, the CEM system was removed.

Four simultaneous loads applied in synchronous stroke control at the CEM pockets demonstrated the feasibility of alternative testing methods for nonconventional passenger equipment.

6. References

1. Carolan, M., and Muhlanger, M. P. (2009 Oct.). Strategy for alternative occupant volume testing. In *Proceedings of the ASME 2009 Rail Transportation Division Fall Conference* [20–21 Oct. 2009, Fort Worth, TX]. New York, NY: American Society of Mechanical Engineers.
2. Fries, R. H., and Anankitpaiboon, S. (2010 Nov.). *800,000-Pound quasi-static end-load test of crash energy management equipped car, test 1* (U.S. Department of Transportation Report No. DOT/FRA/ORD-10/12). Washington, DC: Office of Railroad Policy and Development, Federal Railroad Administration.
http://www.fra.dot.gov/rpd/downloads/TR_800K_pound_test_102910.pdf.
3. Fries, R. H., Tunna, L., and Anankitpaiboon, S. (2011). *800,000-Pound quasi-static end-load test of crash energy management equipped car, test 2* (U.S. Department of Transportation Report No. DOT/FRA/ORD-13/04). Washington, DC: Office of Railroad Policy and Development, Federal Railroad Administration.
4. Carolan, M., Perlman, B., and Tyrell, D. (2012 Apr.). Crippling Test of a Budd Pioneer Passenger Car. In *Proceedings of the ASME 2012 Joint Rail Conference* [16–18 Oct. 2012, Philadelphia, PA]. New York, NY: American Society of Mechanical Engineers.
5. Transportation Technology Center, Inc. (2011 June). *Test implementation plan for crippling load test of Budd Pioneer Car 244*, Prepared for Federal Railroad Administration Equipment Safety Research Program. Washington, DC: U.S. Department of Transportation.

Abbreviations and Acronyms

CEM	crash energy management
FRA	Federal Railroad Administration
PEAM	primary energy absorbing mechanism
TTC	Transportation Technology Center (the site)
TTCI	Transportation Technology Center, Inc. (the company)