



U.S. Department of  
Transportation

**Federal Railroad  
Administration**

## Safety Evaluation of High-Speed Rail Bogie Concepts

---

Office of Research  
and Development  
Washington, DC 20590

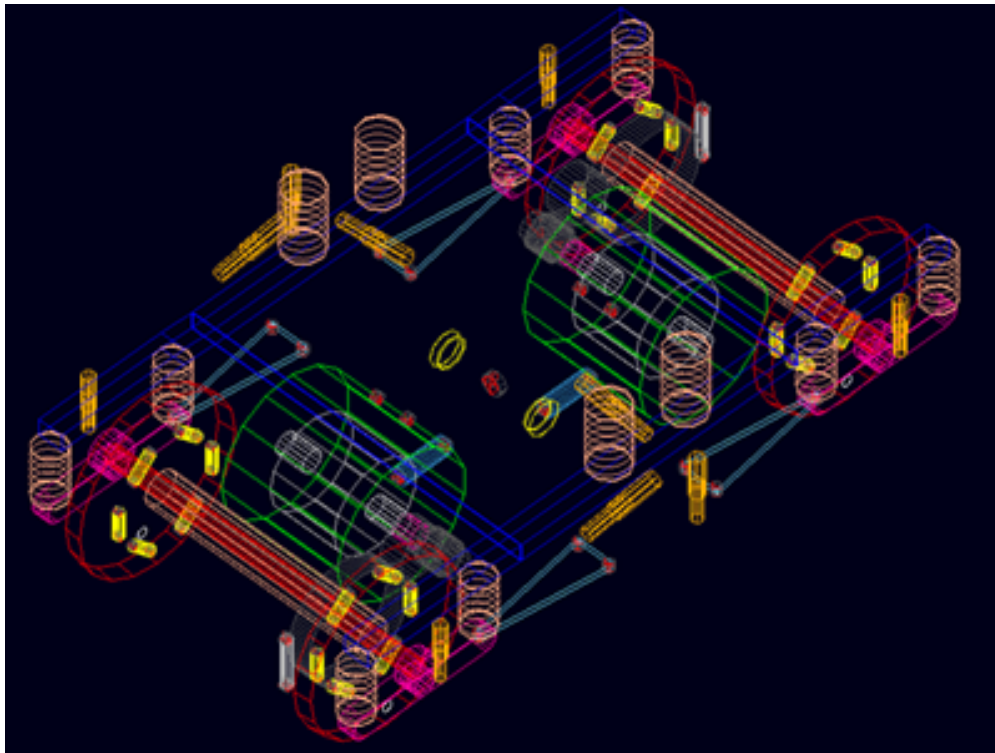

(a) Truck Model in ADAMS/Rail

#### NOTICE

This document is disseminated under the sponsorship of the Department of Transportation in the interest of information exchange. The United States Government assumes no liability for its contents or use thereof. Any opinions, findings and conclusions, or recommendations expressed in this material do not necessarily reflect the views or policies of the United States Government, nor does mention of trade names, commercial products, or organizations imply endorsement by the United States Government. The United States Government assumes no liability for the content or use of the material contained in this document.

#### NOTICE

The United States Government does not endorse products or manufacturers. Trade or manufacturers' names appear herein solely because they are considered essential to the objective of this report.

**REPORT DOCUMENTATION PAGE***Form Approved  
OMB No. 0704-0188*

Public reporting burden for this collection of information is estimated to average 1 hour per response, including the time for reviewing instructions, searching existing data sources, gathering and maintaining the data needed, and completing and reviewing the collection of information. Send comments regarding this burden estimate or any other aspect of this collection of information, including suggestions for reducing this burden, to Washington Headquarters Services, Directorate for Information Operations and Reports, 1215 Jefferson Davis Highway, Suite 1204, Arlington, VA 22202-4302, and to the Office of Management and Budget, Paperwork Reduction Project (0704-0188), Washington, DC 20503.

1. AGENCY USE ONLY (Leave blank)		2. REPORT DATE October 2013	3. REPORT TYPE AND DATES COVERED Final Report	
4. TITLE AND SUBTITLE Safety Evaluation of High-Speed Rail (HSR) Bogie Concepts: Comparative evaluations of HSR bogie design concepts for operation up to 125 mph			5. FUNDING NUMBERS	
6. AUTHOR(S) and FRA COTR Adrian Gorski, Dennis Richter, Andrew Smith, Jingjun Zhang, David Watson, and Robert Spinelli Jr.				
7. PERFORMING ORGANIZATION NAME(S) AND ADDRESS(ES) GE Transportation 2901 East Lake Road Erie, Pennsylvania 16531			8. PERFORMING ORGANIZATION REPORT NUMBER	
9. SPONSORING/MONITORING AGENCY NAME(S) AND ADDRESS(ES) U.S. Department of Transportation Federal Railroad Administration Office of Research and Development Washington, DC 20590			10. SPONSORING/MONITORING AGENCY REPORT NUMBER DOT/FRA/ORD-13/42	
11. SUPPLEMENTARY NOTES COTR: S.K. (John) Punwani				
12a. DISTRIBUTION/AVAILABILITY STATEMENT This document is available to the public through the FRA Web site at <a href="http://www.fra.dot.gov">www.fra.dot.gov</a> , or by calling (202) 493-1300.			12b. DISTRIBUTION CODE	
13. ABSTRACT (Maximum 200 words) The study defines the basic design concepts required to provide a safe, reliable, high-speed bogie for the next generation PRIIA passenger locomotive. The requirements and conditions for the U.S. market create unique design challenges that currently cannot be addressed by a U.S.-based manufacturer. A global survey identified dominant design trends focused on reducing P2 forces and optimizing bogie stability, curving performance, and ride quality. A likely design configuration with Bo-Bo arrangement was defined for the Task 2 stability analysis. The design of experiments, response surface techniques, and design space method used for the stability analysis demonstrated that a feasible design space of suspension variables could be identified for the conditions evaluated. The coinciding requirements for a higher horsepower engine, Tier 4 emissions, and crashworthiness equipment will add significant weight to the next generation locomotive. In order to meet the P2 limit of 82,000 pounds force at 125 mph, the next generation passenger locomotive will require a frame-hung traction motor, most likely with fully suspended drivetrain, and a disc brake system added to the already existing tread brake and dynamic brake systems. A preliminary safety FMEA concluded the new drivetrain would likely not increase safety risk.				
14. SUBJECT TERMS High-Speed Rail (HSR), bogie, concepts, Bo-Bo arrangement, Pareto plot, stability analysis, P2 force, PRIIA locomotive			15. NUMBER OF PAGES 158	
			16. PRICE CODE	
17. SECURITY CLASSIFICATION OF REPORT Unclassified	18. SECURITY CLASSIFICATION OF THIS PAGE Unclassified	19. SECURITY CLASSIFICATION OF ABSTRACT Unclassified	20. LIMITATION OF ABSTRACT	

NSN 7540-01-280-5500

Standard Form 298 (Rev. 2-89)  
Prescribed by ANSI Std. Z39-18  
298-102

# Contents

---

Executive Summary .....	1
1. Introduction .....	4
1.1 Background .....	4
1.2 Objectives .....	5
1.3 Overall approach .....	5
1.4 Scope .....	6
1.5 Organization of the report .....	6
2. Reports .....	8
2.1 Task 1 - Technology Survey of High-Speed Bogie Concepts.....	8
2.2 Task 2 - HSR Bogie Running Stability Summary Report.....	27
2.3 Task 3 - Dynamic Load Summary Report.....	65
2.4 Task 4 - Braking Capability Summary Report.....	76
2.5 Task 5 - Wheel and Axle Summary Report .....	91
2.6 Task 6 - Locked Axle Safety Risk Assessment Summary Report .....	99
3. Report Conclusions .....	104
4. References .....	106
Appendix A. Truck Design Fundamentals.....	107
Appendix B. Survey results tables – Truck design parameters .....	120
Appendix C. Basic configurations of surveyed trucks.....	125
Appendix D. Task Modeling Results.....	129
Abbreviations and Acronyms .....	150



## Illustrations

---

Figure 2.1.1-a: Interaction between wheel and rail geometries .....	8
Figure 2.1.3-a: Bo-Bo wheel arrangement.....	12
Figure 2.1.3-b: Surveyed locomotive truck speeds.....	12
Figure 2.1.3-c: Surveyed locomotive truck speeds.....	13
Figure 2.1.3-d: Wheel diameters.....	14
Figure 2.1.3-e: Types of fabricated truck frames.....	15
Figure 2.1.3-f: Surveyed wheel bases .....	15
Figure 2.1.3-g: Axle guiding device .....	16
Figure 2.1.3-h: Traction links .....	16
Figure 2.1.3-i: Motor suspensions .....	18
Figure 2.1.3-j: Survey results of motor suspensions.....	19
Figure 2.1.3-k: Relation between unsprung mass and locomotive weight for P2 force limit of 82,000 lb (track parameters are from PRIIA spec).....	20
Figure 2.1.3-l: Brake arrangements .....	21
Figure 2.1.3-m: Wheel-mounted disc brake .....	21
Figure 2.1.3-n: Axle mounted disc brake.....	22
Figure 2.1.3-o: Hollow-shaft (quill) mounted disc brake (Bombardier ALP45 DP).....	22
Figure 2.1.3-p: Discs mounted on separate shaft (Siemens SF1) .....	22
Figure 2.1.3-q: Truck/Body traction connections .....	24
Figure 2.2.2-a: High-speed truck used for Task 2 analysis: frame-hung motor and fully suspended drivetrain .....	28
Figure 2.2.2-b: ADAMS/Rail Models for dynamic analysis .....	29
Figure 2.2.2-c: MCAT track definition for simulations.....	30
Figure 2.2.2-d: Wheel and rail profiles used for the simulations.....	33
Figure 2.2.2-e: Parameter definition for contact geometry calculation .....	34
Figure 2.2.2-f: Contact geometry of new Amtrak standard wheel profile and new AREMA136 rail profile.....	34
Figure 2.2.2-g: Contact geometry of new Amtrak standard wheel profile and worn rail profile on straight track.....	35
Figure 2.2.2-h: Contact geometry of new Amtrak standard wheel profile and worn rail profile on curved track.....	36
Figure 2.2.2-i: Contact geometry of worn wheel profile and worn rail profile on straight track .	37

Figure 2.2.2-j: Contact geometry of worn wheel profile and worn rail profile on curved track ..	38
Figure 2.2.2-k: Parameters to be used for DOE analysis .....	40
Figure 2.2.2-l: Comparison of the responses on curved track between MCAT track inputs and measured random track inputs .....	45
Figure 2.2.2-m: Comparison of the responses on straight track between MCAT track inputs and measured random track inputs – Measured class 5 track irregularities versus MCAT class 5 inputs, frame-hung motor, Loco Speed 95 mph (MCAT Class 5 inputs on curved track are used for straight track) .....	47
Figure 2.2.2-n: Strategy of determining feasible design space .....	49
Figure 2.2.3-a: Regression functions of the response surfaces .....	50
Figure 2.2.3-b: Pareto plot .....	51
Figure 2.2.3-c: Sensitivity plots .....	51
Figure 2.2.3-d: Stability analysis of the selected concept with frame-hung motor .....	52
Figure 2.2.3-e: Lateral displacement of leading axle – truck with axle-hung motor .....	53
Figure 2.2.3-f: Lateral displacement of leading axle – truck with frame-hung motor .....	54
Figure 2.2.3-g: Pareto and Sensitivity analysis of linear critical speed – 2-axle truck with frame-hung motor, worn wheel, and worn rail profiles .....	55
Figure 2.2.3-h: Example of simulation results – frame-hung motor, Class 7 MCAT straight track inputs, new wheel-rail profiles, 125 mph, middle points (level 2) of the suspension parameters .....	56
Figure 2.2.3-i: Sensitivity analysis results for truck with frame-hung motor, new wheel and worn rail profiles, Class 7 track, 125 mph .....	57
Figure 2.2.3-j: Comparison of sensitivity results between different wheel-rail profile combinations (frame-hung motor, Class 7 track, 125 mph) .....	59
Figure 2.2.3-k: Example of two-dimensional design space .....	60
Figure 2.2.3-l: Minimization process of lateral car body acceleration in $m/s^2$ (frame-hung motor, straight track, new wheel, worn rail, MCAT Class 7 track, speed 125 mph) .....	61
Figure 2.2.3-m: Minimization process of lateral truck acceleration in $m/s^2$ (frame-hung motor, straight track, new wheel, worn rail, MCAT Class 7 track, speed 125 mph) .....	61
Figure 2.2.3-n: Minimization process of L/V of leading axle (frame-hung motor, 1.1 degree curve, 6” superelevation, new wheel, worn rail, MCAT Class 7 track, speed 125 mph) .....	62
Figure 2.2.3-o: Minimization process of track shift force of leading axle in N (frame-hung motor, 1.1 degree curve, 6” superelevation, new wheel, worn rail, MCAT Class 7 track, speed 125 mph) .....	62
Figure 2.3.3-a: P2 force for PRIIA loco compared to existing diesel rolling stock .....	68
Figure 2.3.3-b: P2 force for PRIIA loco: loco weight versus unsprung weight, 125 mph .....	69
Figure 2.3.3-c: P2 force for PRIIA loco: loco weight versus unsprung weight, 110 mph .....	70

Figure 2.3.3-d: Main effects plot for parameters used in the P2 force equation for 125 mph operation .....	71
Figure 2.3.3-e: Comparison of potential P2 forces on different classes of track.....	72
Figure 2.3.3-f: Comparison of P2 forces on Class 4 track, at 60 mph, for freight and passenger locomotives .....	73
Figure 2.3.3-g: P2 force – Passenger versus Freight for Class 4 track operation.....	73
Figure 2.4.1-a: Rail network divided by area of the country .....	77
Figure 2.4.2-a: Approach for utilizing the Gordon and Orringer study to draw conclusions about brake requirements on PRIIA locomotive .....	79
Figure 2.4.3.1-a: Energy absorbed by each wheel for passenger and freight locomotives.....	80
Figure 2.4.3.2-a: Locomotive brake types .....	82
Figure 2.4.3.2-b: Locomotive wheel energy reduction resulting from disc brake use .....	83
Figure 2.4.3.2-c: Locomotive wheel energy reduction resulting from use of blended brake .....	84
Figure 2.4.3.2-d: Wheel power and Heat Flux for a 285,000-pound PRIIA locomotive in Air only Emergency Brake application based on approach used in the Gordon and Orringer study .	87
Figure 2.4.3.2-e: Assessment of expected wheel temperature for a PRIIA loco utilizing tread brakes only in emergency stop from 125 mph based on the wheel temperatures from the Gordon and Orringer study .....	88
Figure 2.5.3-a: Comparison of loading assumptions used around the world for axle design.....	93
Figure 2.5.3-b: Rotating bending fatigue tests for press-fitted axles (Spec C, E represent induction hardening processes).....	95
Figure 2.5.3-c: Comparison of allowable alternating stress as a function of ultimate strength....	96
Figure 2.5.3-d: Failure mode as a function of wheel seat diameter ratio.....	97
Figure 2.6.1-a: Axle-hung motor design.....	99
Figure 2.6.1-b: Frame-hung motor HS coupling design.....	100
Figure 2.6.1-c: Frame-hung motor LS coupling design.....	100

## Tables

---

Table 2.1.2-a: Parameters quantified in survey .....	11
Table 2.2.2-a: MCAT geometry, tangent track, Class 7 track .....	30
Table 2.2.2-b: MCAT geometry, curved track, Class 7, CD = 6 inches.....	31
Table 2.2.2-c: Configuration of curved track.....	31
Table 2.2.2-d: Wheel and rail profile specification .....	31
Table 2.2.2-e: 10 major design variables for modeling .....	39
Table 2.2.2-f: MCAT performance parameters .....	41
Table 2.2.2-g: DOE table .....	42
Table 2.2.2-h: 3 levels of suspension parameters .....	43
Table 2.2.2-i: Combinations of track and wheel-rail inputs for response surface analysis .....	48
Table 2.2.3-a: Feasible stable and safe design space of truck with frame-hung motor .....	63
Table 2.4.3.1-a: Comparison of kinetic energy between freight and passenger locomotives .	80
Table 2.4.3.1-b: Comparison of kinetic energy between Class 43 and PIIIA locomotives.....	81
Table 2.4.3.2-a: Comparison of heat flux input between Arrow-III cars and diesel locomotives .....	86
Table 2.5.3-a: Matrix of high-speed locomotive applications and relevant application data .....	92
Table 2.5.3-b: Comparison of material standards for axles .....	94
Table 2.6.2-a: Severity scoring definition.....	101

## **Executive Summary**

---

### **Background**

The Federal Railroad Administration (FRA), through its Office of Research and Development, is facilitating the development of safe, efficient high-speed (HS) passenger rail systems in the United States. To this end, FRA will identify and support key innovative technologies in a range of rail industries, including track and structures, train control, human factors, passenger cars, and passenger locomotives.

With respect to passenger locomotives, the “Passenger Rail Investment and Improvement Act” (PRIIA) specifies the need for a diesel-electric passenger locomotive capable of operating at a sustained speed of 125 mph. Perhaps the most critical subsystem for maintaining safe, stable, and comfortable operation at increasing speeds is the locomotive truck or bogie (the words truck and bogie are used interchangeably in this study).

In order to understand the truck design concepts and tradeoffs required to ensure safe, reliable operation while meeting PRIIA requirements, FRA has contracted GE Transportation (GET) to conduct a “comparative evaluation of different HSR bogie concepts for operation up to 125 mph.” This document reports the methods, results, and major conclusions of that study. It focuses only on bogie system designs.

### **Next generation PRIIA unique operational & design requirements**

A meaningful assessment of high-speed bogie design concepts for operation in the United States cannot be provided or understood without first defining the U.S. operating conditions and design requirements that make the next generation PRIIA-specified application unique and challenging. The PRIIA specifications emphasize that a vital part of the U.S. intercity passenger rail network will continue to consist of Amtrak routes which share right-of-way with freight railroads. Therefore, next generation HS passenger locomotives must continue to have the capability to run on all classes of track. This will likely result in suspension design tradeoffs, as a suspension system optimized for high speeds on class 7 track will probably not be optimal for lower speeds on lower classes of track.

The high horsepower diesel engine required for 125 mph speed adds significant weight to the locomotive compared with most other high-speed locomotives, which are almost all powered by electricity only. Additionally, the coming Tier 4 emissions regulation will add significant weight to the engine, as will the additional structural material needed to meet the crashworthiness requirements that will also be part of the next generation PRIIA locomotives. Therefore, the U.S. passenger locomotive that meets PRIIA, Tier 4, and crashworthiness standards will have an estimated axle weight of between 30 and 33 metric tons (MT). This compares with an axle load of 22 MT or less for the high-speed locomotives surveyed in this report.

Finally, the PRIIA specifications will require a P2 force limit of 82,000 lbf. This is the same as the P2 force of an F40 locomotive at 110 mph. At 125 mph, the current F40, which weighs 260,000 lbf, will exceed the PRIIA limit. GE estimates the next generation PRIIA capable of 125 mph will weigh from 270,000 to as much as 300,000 lbf.

## **Summary of Results**

In order to provide a thorough evaluation of HSR bogie concepts and meet FRA objectives, GET scoped and conducted the study as the six separate tasks listed below:

Task 1 – Global survey of high-speed rail (HSR) concepts

Task 2 – Running stability analysis

Task 3 – Dynamic loads on track of P2 force and track panel shift force

Task 4 – Braking capability

Task 5 – Fatigue reliability of wheel and axle

Task 6 – Drivetrain arrangement safety risk assessment

### *Key study highlights:*

The study first defines the design requirements for the next generation PRIIA locomotive. The requirements and operating conditions create a unique design challenge. Currently, no U.S. manufacturer provides a passenger locomotive that meets the requirements, which include meeting the P2 limit of 82,000 lbf. The global survey identified dominant HS design trends focused on reducing P2 forces and optimizing stability, curving performance, and ride quality. A likely truck design configuration, designated Concept 1, was developed from the survey data to be used in the Task 2 running stability analysis. The design of experiments, response surface techniques, and design space method used in Task 2 demonstrated that a feasible design space of suspension variables could be identified for the conditions evaluated. The report also concludes that the next generation passenger locomotive will require a frame-hung traction motor (even at 110 mph) and a disc brake system added to the already existing tread brake and dynamic brake (DB) systems. The report concludes that, based on GET's current knowledge, the new drivetrain system expected to be required for a high-speed truck with frame-hung motor will likely not create additional safety risks. Finally, it was found that North American axle design methods are conservative compared with European and Japanese methods. U.S. designers may need to develop more accurate methods to calculate axle stress based on input data.

### *Detailed summary:*

The comprehensive global survey identified a number of dominant design trends in current HS bogies manufactured and operated in Europe, Japan, and China. Not surprisingly, the primary design characteristics focus on two general areas: 1) reduction of unsprung mass and total weight in order to minimize P2 forces, and 2) optimization of stability, curving performance, and ride quality.

The survey results also verified that the mostly all-electric locomotives in overseas markets operate at 22 MT per axle or less, much less than the anticipated 32 MT or more for future PRIIA locomotives. From the global survey results, two promising truck design configurations were identified for this study. The first of these, or Concept 1 (see below), was chosen as the configuration to be used in the Task 2 running stability analysis.

In order to understand and quantify the effects of the truck suspension variables on bogie performance, a bogie and locomotive dynamics model was developed using ADAMS/Rail. The locomotive truck design configuration, identified as Concept 1, was used for the evaluation. This configuration included a two-axle truck with Bo-Bo arrangement, frame-hung motor, fabricated frame, and combination of tread and disc brake systems. MCAT track conditions for both straight and curved tracks were used with new and worn conditions for both wheel and rail.

The impact and effect on the safety related performance of the truck suspension parameters was investigated using design of experiments and response surface methods. A design space method was developed and it successfully demonstrated that a feasible combination of suspension parameters can be identified for the truck configuration and variables analyzed. For a complete verifiable design, more conditions and variables than could be included in this study should be evaluated.

The Task 3 study showed that in order to stay within the P2 force limit of 82,000 lbf, the trucks for future PRIIA passenger locomotive would have to incorporate a frame-hung motor to reduce unsprung mass. No current U.S.-produced locomotives can meet the limit at 125 mph. The relatively light F40 will meet the limit at 110 mph, but not at 125 mph. Both the alternating current (AC) and direct current (DC) motor versions of the Genesis locomotives exceed 82,000 lbf at 110 mph.

Braking requirements at 125 mph were evaluated. Braking energy is a function of locomotive mass and speed. Increasing speed to 125 mph increases the amount of energy that must be absorbed by 56 percent. Stopping a four-axle PRIIA diesel powered locomotive at 125 mph requires a bogie with *an additional disc brake system* combined with the already existing tread brake and DB system. For the required emergency stopping event with air-only brake operation, neither a tread nor a disc brake system alone was found to be sufficient.

As unsprung mass is reduced in U.S.-high-speed bogies, the axle will become one of the more significant remaining components. The study compared U.S. and Non-U.S. design practices in the areas of calculation methods for axle stress and input definitions and assumptions for those calculations. We found that the U.S. approach to axle design is more conservative. This is felt to be partly due to the slower running speeds that result in lower P2 forces even with the heavier axle, and perhaps more significantly due to the lack of reliable data with which to accurately characterize axle loading. Going forward, North American axle designers may find it helpful to define axle loads less conservatively with the aid of more accurate input data. In addition, it may be necessary to consider higher performance materials and improved axle processing techniques to better improve fatigue resistance. Industry and government cooperation to develop better data and joint design standards should be considered as a way to ensure safe, reliable, and optimized high-speed axle designs.

An assessment was made of the safety risks associated with the three basic drivetrain designs most likely to be used for 125 mph applications in North America. An FMEA was conducted for each of the design cases to assess the potential for increased risk. It was concluded that locked axle has historically not led to derailment and is therefore not considered a safety concern. Based on GE's best current knowledge, it was considered unlikely that specific additional safety requirements in the design of the frame-hung traction motor concept would be required. In other words, although there may be additional reliability concerns associated with high-speed designs, those concerns were not believed to be tied to an increase in safety risk. This is another area in which industry standards, jointly developed by industry and Government for certain drivetrain components and systems, should be considered in order to ensure safe optimum designs.

The results indicate that the goal of meeting the PRIIA requirements will have a significant impact on bogie complexity, cost, and maintenance. A study is recommended to determine the cost-benefit tradeoffs between realizing a specific P2 limit and potentially incurring additional purchase and operating costs.

# 1. Introduction

---

## 1.1 Background

The Federal Railroad Administration (FRA), through its Office of Research and Development, is researching new technologies that will benefit the U.S. high-speed rail system. The primary goals of these efforts will be focused on achieving safe, efficient, and effective deployment of integrated passenger rail systems in the United States. To this end, FRA will identify and support key innovative technologies in a range of rail industries, including track and structures, train control, human factors, passenger cars, and passenger locomotives.

With respect to locomotives, the “Passenger Rail Investment and Improvement Act” (PRIIA) specifies the need for a diesel-electric passenger locomotive capable of operating at a sustained speed of 125 miles per hour (mph). This report focuses specifically on the bogie system designs that will be required for a locomotive to safely and reliably meet the PRIIA requirements.

The PRIIA specifications also state that a vital part of the U.S. intercity passenger rail network will continue to be the Amtrak long distance routes which share right-of-way with freight railroads. Therefore, an additional requirement for the next generation HS passenger locomotives is the capability to operate on all classes of track.

### *Unique North American (NA) Operating Environment for Passenger Rail*

The requirement to develop High-Speed diesel locomotives capable of 125 mph on class 7 track, and also capable of operating throughout the Amtrak long distance routes on all other classes of track, presents unique challenges not found in other nonU.S. high-speed rail applications.

In addition to the requirement of being able to operate on all classes of track, the diesel engine and its required support systems significantly increase the weight of the locomotive compared with a conventional all-electric locomotive. The diesel engine weight in North America is further increased by the Tier 4 engine emissions requirement, as well as by new crashworthiness standards, both of which add significant additional weight to the locomotive. The estimated axle loads for the U.S. application will be 30 metric tons (MT) or more, compared with the 22 MT or less loads currently in place for nonU.S. applications.

Finally, the new PRIIA P2 force limit of 82,000 pounds (lb) is more stringent than past requirements. Most existing passenger locomotives do not meet this requirement even at the significantly slower speed of 100 mph (the relatively light F40 locomotive, at 3200 hp, is the exception).

Currently, the authors are unaware of any U.S.-based manufacturers with locomotive truck technology capable of operating safely at 125 mph.

### *Purpose and focus of this Study*

In order to define the basic requirements for a safe HS passenger locomotive truck, FRA commissioned this study to conduct a comprehensive evaluation of the different truck design concepts with respect to North American operating conditions and requirements, and to determine the best configuration of components and design parameters for High-Speed Rail (HSR) bogies that can safely and reliably guide a diesel-electric locomotive on all classes of U.S. track, and at a sustained speed of 125 mph on class 7 track.



Several important areas for further study that may benefit the rail industry were identified in this report.

## **1.2 Objectives**

The following list presents the key objectives of this study:

- Highlight the differences and unique requirements that define the North American operating environment and locomotive requirements.
- Conduct a global survey of the major locomotive truck design concepts and components.
- Determine a feasible configuration of components and design parameters for HSR bogies that can safely and reliably guide a diesel-electric locomotive on all classes of U.S. track, at a sustained speed of 125 mph on class 7 track.
- Include a proactive assessment of safety risks associated with HSR locomotive trucks and mitigation recommendations if needed.

## **1.3 Overall approach**

The study was scoped and planned by GET as six separate tasks designed to achieve the study objectives. The tasks with brief summaries, as stated in the original scope of work (SOW), are listed below. As the study progressed, it became apparent that some tasks needed to be modified, either because the changes better met the FRA objectives, or because the tasks could not be completed meaningfully within the limitations of this study. These changes will be identified within the specific report sections that describe each task. Note also that the title for Task 6 was changed as explained below.

### **Task 1 – Literature survey of HSR bogie concepts**

Evaluate various HSR bogie concepts; understand their applicability, performance range, relative costs, and impact on safety.

### **Task 2 – Running stability**

Investigate the impact of suspension system design including primary, secondary suspensions, connections of the bogie to car body, alternative configurations such as frame-hung motors, and wheel base dimension, as well as passive and active steering; understand the engineering feasibility and limitation of the suspension system.

### **Task 3 – Dynamic loads on track including P2 force and track panel shift force**

Evaluate the impact of locomotive weight, motor suspension type, and the suspension parameters on P2 and track shift force.

### **Task 4 – Braking capability**

Evaluate the capabilities and limitations of different brake arrangements including tread brakes, disc brakes, and a combination of tread and disc brakes.

### **Task 5 – Fatigue reliability of wheel and axle**

Evaluate the impact of high-speed application on wheel-axle fatigue life. Investigate the duty cycle of axle load under U.S. track conditions and the effects of reduced axle weight.

## **Task 6 – Drivetrain arrangement safety risk assessment**

The title for this task has been changed from the original contract proposal and document. The original title was “Locked axle.” The original task description stated “Evaluate bogie response to locked axle conditions and other drivetrain component failures.” Since the study considered the entire drivetrain, not just the locked axle condition, the more correct title was used.

The terms truck and bogie are used interchangeably in this report.

### **1.4 Scope**

This study is focused on passenger locomotive truck design concepts required to safely operate at 125 mph and navigate the unique operating conditions of the United States, as well as meet the requirements defined in the recent PRIIA specifications. The following summarizes the scope in more detail:

- This study is specifically concerned with passenger locomotive truck design concepts required to safely and reliably operate at 125 mph on Class 7 track and in other conditions as defined below.
- The design parameters for this study are focused on the U.S. operating environment which includes Amtrak long distance routes which share right-of-way with freight railroads; high-speed bogies must be capable of operating on those routes and on all other classes of track.
- The design requirements for this study specifically include a diesel-powered locomotive system capable of sustaining 125 mph.
- Except where it impacts safety, reliability is not generally within the scope of this study.

Though GE recognizes the advantages to the industry of standardizing certain truck components and systems, this is not within the contracted scope. Should FRA coordinate and support further study or discussion in this area, GE would like to be involved and contribute to the success of such activities.

### **1.5 Organization of the report**

The report is organized and formatted in the standard FRA technical report format.

In the body of the report, each of the six tasks described above is reported as a separate report section with definition, approach, results, and conclusions for each.

In order to provide a complete but also readable report, many of the detailed tables, truck design configurations, and graphic results from Tasks 1 and 2 are provided as Appendices 2–4.

A detailed section on the basics of truck design is provided in Appendix 1. An understanding of the concepts presented here is critical to understanding the report’s approach, results, and conclusions. Appendix 1 is summarized at the beginning of the Task 1 report.

### **Notice**

*The conclusions stated in this report are based on the knowledge gained during this project, GE Transportation's past experience and best current knowledge. While GE is confident in the general conclusions drawn from this limited study, it is possible that a more thorough effort, such as an actual truck design and development project, would result in new knowledge that could modify these conclusions. The results, therefore, should not be considered final design recommendations.*

### **Notice on use of graphics**

*Much of the truck related graphics reviewed during this study were obtained from manufacturers' brochures and Web sites. Due to IP concerns, we are not able to include these in a public document. Where possible and allowed, we have provided links to some of these resources in the reference section.*

### **Nomenclature**

*Within this report, the words truck and bogie are used interchangeably. An acronym and abbreviation definition list is provided at the end of the report.*

## 2. Reports

---

### 2.1 Task 1—Technology Survey of High-Speed Bogie Concepts

#### 2.1.1 Definition

The purpose of Task 1 is to conduct a review of worldwide high-speed truck design practices. Comparisons are also made between the typical overseas operating conditions of high-speed rail and the unique conditions required for the PRIIA application in the United States. A thorough survey of available design information was conducted and the most significant design trends relevant to this study were identified.

The search was conducted by personnel at GE Research (GER), GET, and a contract engineer with over 20 years of truck design experience. Although specific design information was not as available as originally hoped, we were able to review dozens of truck designs for major high-speed passenger locomotives throughout the world and identify a number of important design trends. These trends focus on reducing weight and unsprung mass, as well as controlling stability, curving performance, and ride quality.

A comparison of the relative costs of the key products identified was also a goal of the original project scope, but useful cost information was generally unavailable, and as a competitor, it would be inappropriate for GET to request or acquire cost and price data.

#### Truck Design Requirements & Performance Characteristics

The truck is the interface between the locomotive and the track. As illustrated in Figure 2.1.1-a below, the interactions between wheel and track geometries provide the dynamic inputs to the truck and locomotive. A complete understanding of the correct and relevant inputs and system responses is fundamental to designing a safe and reliable passenger locomotive truck.

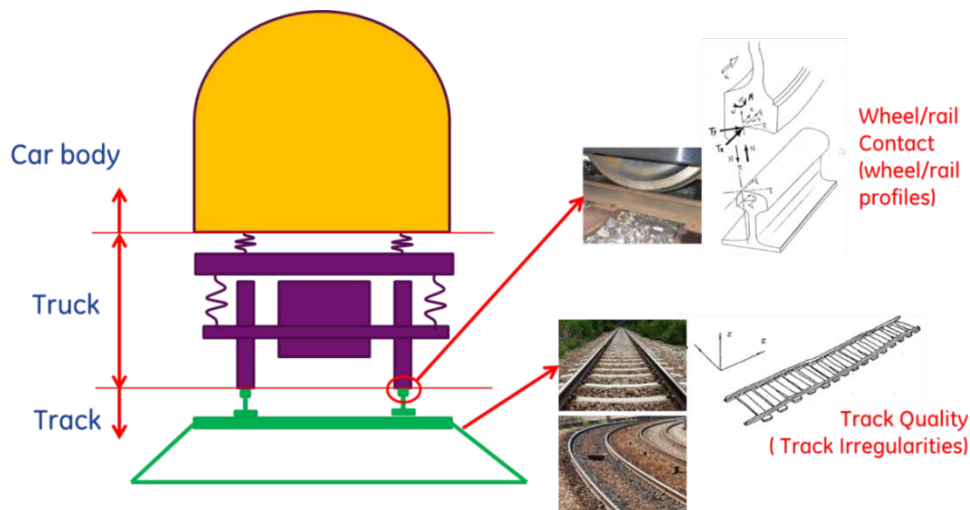

Figure 2.1.1-a: Interaction between wheel and rail geometries

### ***Truck functional requirements***

The truck subsystem provides the following basic functions:

- 1) support the car body weight and distribute the locomotive weight to the axles
- 2) guide and steer the locomotive on the tracks safely and with stability under all operating conditions
- 3) provide traction and braking effort between the wheels and rails
- 4) transmit traction and braking force to the car body
- 5) reduce and isolate vibrations and impact loads from wheel-track interactions
- 6) mount and support auxiliary components and equipment

### ***Key performance measures***

The basic functional requirements stated above must be met by a system that will provide an acceptable combination of the following six key truck performance measures in a cost effective, reliable, and safe package.

- 1) Stability under all operating conditions
- 2) Derailment prevention in all conditions
- 3) Wheel-rail dynamic forces
- 4) Braking capability
- 5) Ride quality and comfort
- 6) Component and structural reliability and life

Understanding these functional requirements is important to understanding design tradeoffs and the results of this study. All six requirements are described in significantly more detail in Appendix A.

### **Comparison of Operating Conditions**

To draw meaningful conclusions from a survey of worldwide high-speed truck design concepts requires an understanding of the operating conditions in the overseas applications and how they compare with U.S. operating conditions.

The differences in U.S. and overseas requirements and conditions are discussed in the introduction section and elsewhere in this study. Axle load and track quality are summarized again here because these are particularly relevant to the U.S. design requirements and report conclusions.

**Locomotive weight and axle load** – Although some of the truck manufacturers claim that their designs could also be used for applications of diesel locomotives, most of the surveyed locomotives are electric. Electric-powered locomotives tend to be significantly lighter than diesel locomotives. The diesel engine and supporting equipment (e.g., the cooling and oil systems) add considerable weight to the locomotive. In North America, the impending Tier 4

regulations will force the addition of still more weight in order to provide the necessary emissions reduction systems. Current best estimates are that the future PRIIA and Tier 4 certified passenger locomotive will have an axle load of approximately 33 MT or higher.

To meet the specified P2 force limit, this high axle load will drive a lot of design changes. What could work well in the existing truck design which is used in other countries may no longer be applicable for U.S. high-speed locomotive—for example, wheel-mounted disc brake, truck frame, and partially suspended drivetrain. A fully suspended drivetrain will be necessary for U.S. design to meet the P2 force requirement.

**Track quality** – The track geometry and quality standards in the United States are different from those in other countries. In general, the U.S. track classes have much larger allowable geometrical deviations than other countries. This means that the U.S. tracks will have much more and higher excitations.

### **2.1.2 Approach**

A thorough survey of available literature and information was conducted to identify current HSR bogie design characteristics and trends in all the major world markets and applications.

The following areas were specifically targeted:

- Focus on systems and components that specifically relate to the six key performance characteristics described in the previous truck design section 2.1.1.
- Designs specifically for high speeds, defined for this study as 125 mph or higher
- Axle loads—significant impact on P2 forces
- New developments and trends

The following major locomotive builders and their products were included in the survey:

- Siemens (Germany)
- Bombardier (Canada)
- Alstom (France)
- Voith (Germany)
- Vossloh (Germany)
- Talgo (Spain)
- CAF (Spain)
- CSR/NSR (China)
- Ansaldo Breda (Italy)
- Hitachi Rail (Japan)
- Antranz (Sweden)
- EMD (USA)
- MPI (USA)
- GE (USA)

In order to cover the most recent development trend in high-speed truck design, the following high-speed train manufacturers and their products were reviewed as a reference:

- Siemens (Germany)
- Bombardier (Canada)
- Alstom (France)
- Talgo (Spain)
- CSR/CNR (China)
- Kawasaki (Japan)
- Nippon Sharyo (Japan)
- Ansaldo Breda (Italy)
- Hyundai-Rotem (S. Korea)

For information collection, the Internet and other public documents and references were used. Due to limitations of the public information sources, some critical technical data may not be available or complete.

Using the strategy set up above, the survey was conducted following specific designs and parameters for evaluation of performance as shown below in Table 2.1.2-a:

**Table 2.1.2-a: Parameters quantified in survey**

1	Truck type (wheel arrangement)
2	Speed range
3	Axle load
4	Wheel diameter (new vs. worn)
5	Bogie frame design
6	Wheelbase
7	Axle guiding design
8	Primary suspension (vertical)
9	Secondary suspension
10	Motor suspension design
11	Brake design/arrangement
12	Traction link design between truck and car body
13	Builder
14	Drivetrain design
15	Parking brake design/arrangement
16	Axle design
17	Max TE/Axle
18	Power per axle
19	Gauge
20	Minimum curve
21	Bogie weight
22	Application

Items 1–12 are reviewed in detail in the following results section. Items 13–22 are not discussed in the results section, but are listed in Appendix B as part of the tabular data review.

### 2.1.3 Results

Detailed technical data of the survey results for some typical truck products are provided in the tables in Appendix C. Some representative configurations of the truck designs are sketched in Figure C.1a to C.1g. In the following sections, significant findings in each design area will be discussed.

#### Wheel arrangement

Unlike typical North American freight locomotives, the majority of the surveyed trucks for passenger applications have a Bo-Bo arrangement (a locomotive with two bogies, each bogie having two powered axles), as shown below in Figure 2.1.3-a. In a Bo-Bo wheel arrangement, each of the two locomotive trucks has two powered axles. Such an arrangement provides a symmetrical truck layout and component design and is suitable for high-speed operation. Its wheel base is generally smaller than the total wheel base of the three-axle truck. Therefore, it may provide better curving performance.

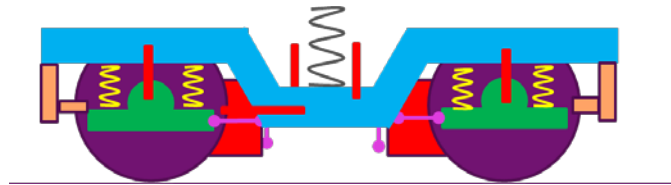
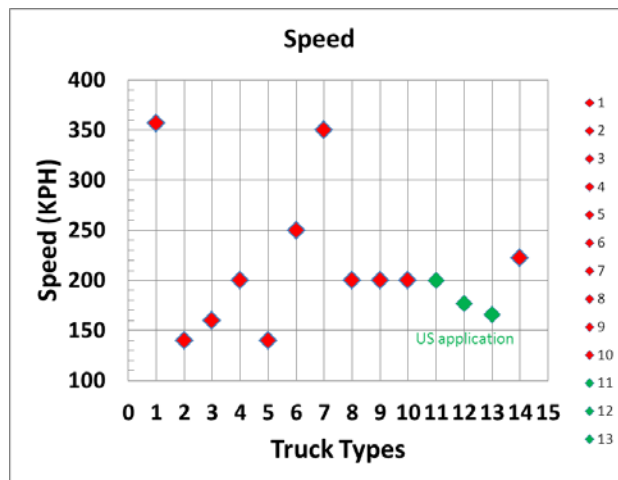

Figure 2.1.3-a: Bo-Bo wheel arrangement

#### Speed range

The speeds of the surveyed locomotive trucks are illustrated in Figure 2.1.3-b. They range from 140 kph (87 mph) to 357 kph (221 mph). The majority of the higher speed (200 kph (125 mph) or more)) applications are found in Europe.



1	2	3	4	5	6	7	8	9	10	11	12	13	14
Siemens, SF1	Siemens, SF2	Siemens, SF3	Siemens, SF4	Bombardier, Flexx Power 140/200	Bombardier, Flexx power 250	Bombardier, Flexx power 350	Alstom, Prima II	Vossloh, Euro 3000AC	Talgo	Bombardier, ALP 45 DP	GE, Genesis	MPI/GE MBTA	Ansaldo Breda, E403

Figure 2.1.3-b: Surveyed locomotive truck speeds



## Axle load

While the axle loads in U.S. applications are approximately 30~33t (67,000~72,750 lb), the axle loads in the rest of the world are much lighter. As shown in Figure 2.1.3-c, all of the nonU.S. trucks surveyed are designed for axle loads of 22 MT or less. The high-speed applications of 350 kph or more have the lowest loads. The axle load of Bombardier Flexx power 350 (truck #7 in Figure 2.1.3-c) is only 17 MT (37,478 lb). The smaller axle load helps keep the P2 force at an acceptable level, even at the much higher speeds.

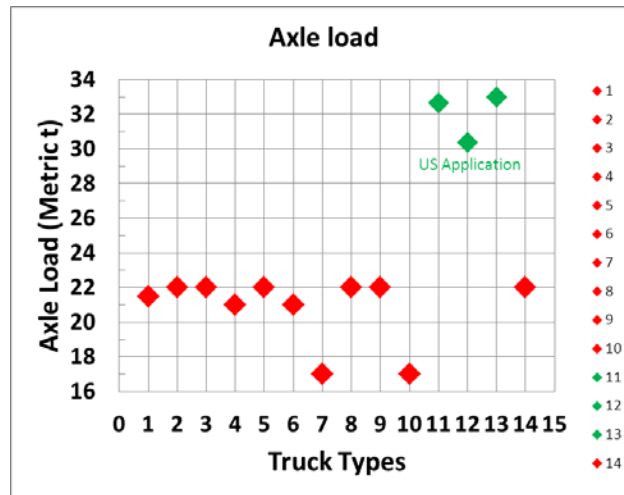

1	2	3	4	5	6	7	8	9	10	11	12	13	14
Siemens, SF1	Siemens, SF2	Siemens, SF3	Siemens, SF4	Bombardier, Flexx Power 140/200	Bombardier, Flexx power 250	Bombardier, Flexx power 350	Alstom, Prima II	Vossloh, Euro 3000AC	Talgo	Bombardier, ALP 45 DP	GE, Genesis	MPI/GE MBTA	Ansaldo Breda, E403

**Figure 2.1.3-c: Surveyed locomotive truck speeds**

## Wheel Diameters

Figure 2.1.3-d below compares wheel diameters of the trucks surveyed. The speed comparison chart is also provided for reference.

The wheel diameters of the surveyed trucks ranged from 1010~1250 mm (39.76~49.21 inches (in)). The selection of the best wheel diameter depends on a number of factors, which include locomotive speed, tractive effort, traction motor rpm and power, required bottom rail and locomotive clearances, unsprung mass, and wheel life requirement.

For a high-speed application, reducing wheel diameter can reduce unsprung mass and P2 force in turn. But a comparison of the speeds of the surveyed locomotives with the wheel diameters below does not show a consistent link between smaller wheel size and higher speed. This affirms the assertion that wheel diameter selection is complicated and dependent on many factors.

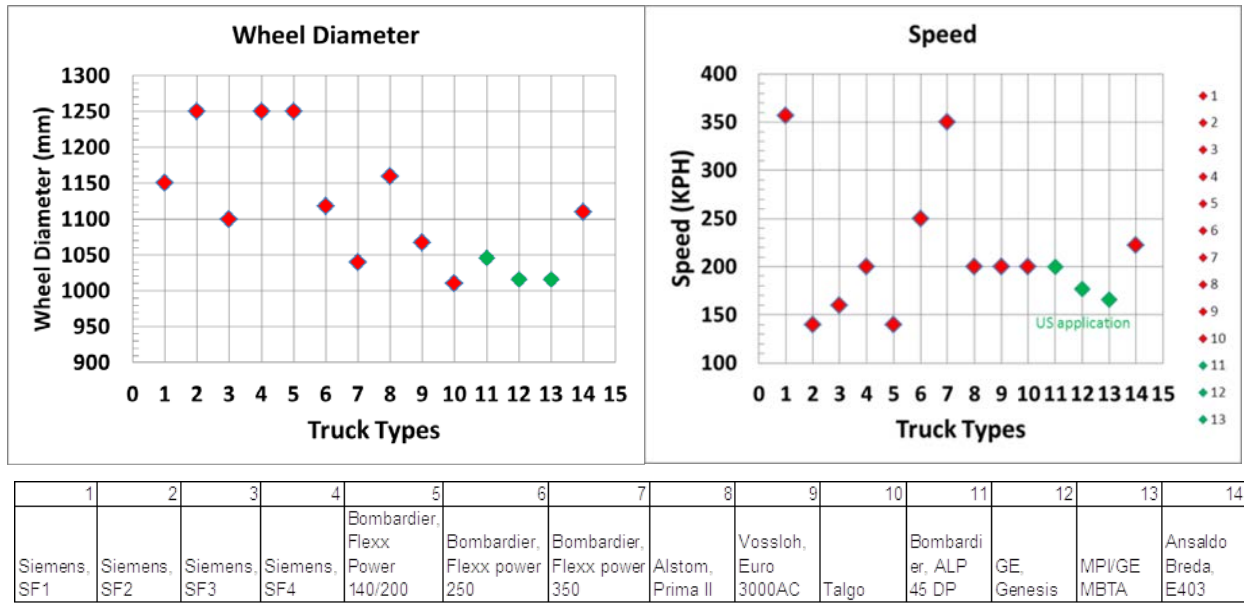

**Figure 2.1.3-d: Wheel diameters**

### Truck frame

Except for the MBTA locomotive truck (#13 on the chart), which is designed by the U.S.-based company, MotivePower, Inc., (MPI), all other surveyed truck frames are fabricated. Fabricated frames are widely used for high-speed applications because they are lighter and easier to manufacture than castings. Through improved welding technology and quality, a fabricated truck frame can meet the strength and reliability requirements. By using the finite life design method based on load duty cycles, a fabricated truck frame can be optimized to meet the required weight and strength requirements. To further reduce weight, some designs even use different materials for the transoms (e.g., Ansaldo-Breda truck in which the entire transom is made of different material and bolted on to the side frame).

There are different shapes of fabricated truck frames. Figure 2.1.3-e below shows four typical truck frame designs. Type A (e.g., Flex Power 140/200 truck of Bombardier) and type B (e.g., GE Genesis truck, Vossloh design) were used in the earlier designs and for relatively lower speeds. Type C (e.g., Vossloh Euro 3000AC) and Type D, in particular, (e.g., Siemens SF1, SF2, SF3 and SF4, Bombardier Flexx Power 250 and Flexx Power 350, Alstom Prima II locomotive truck, Ansaldo Bread truck) are more widely used for higher speed applications. This is, in part, because the taller coil springs are used for the secondary suspension and their longer operating length needs more space between car body and truck frame.

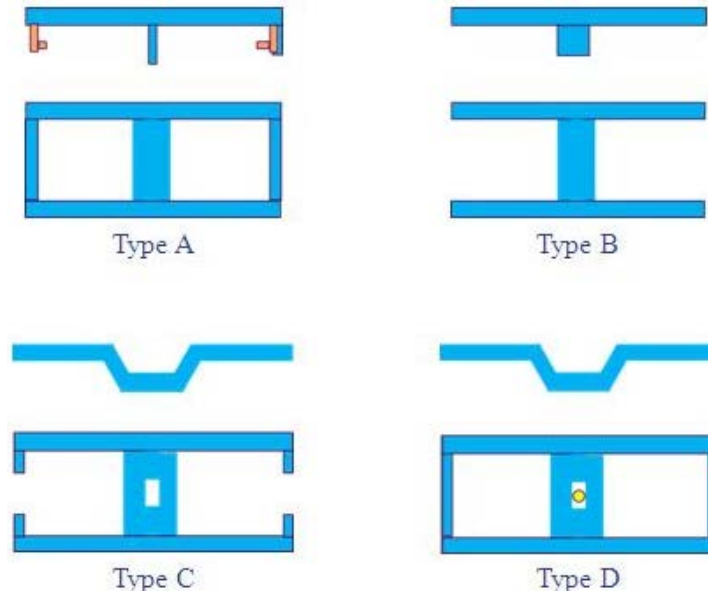

Figure 2.1.3-e: Types of fabricated truck frames

### Wheel base

Figure 2.1.3-f below summarizes the wheel base of different truck designs with ranges from 2600~3000 mm (102.36~118.11 in). A longer wheel base generally improves stability but may result in poor curving performance. There may also be a tradeoff between the desired truck length and packaging requirements in order to adequately contain all the other truck equipment within the available space. A speed chart is again included for reference. Note that, as with wheel diameter, there is no clear correlation among the surveyed trucks between wheelbase and speed.

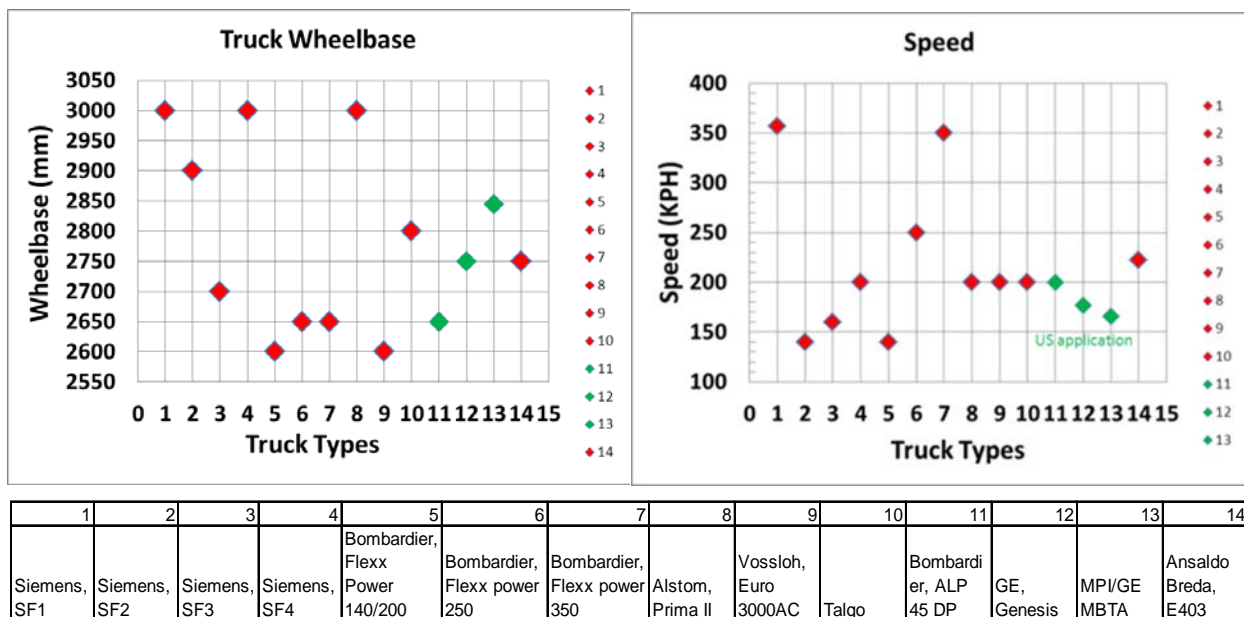
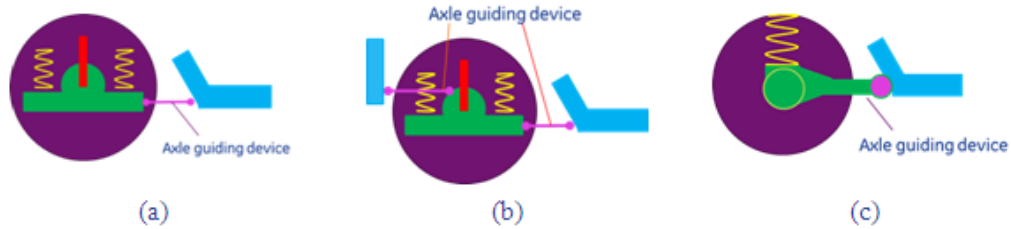

Figure 2.1.3-f: Surveyed wheel bases

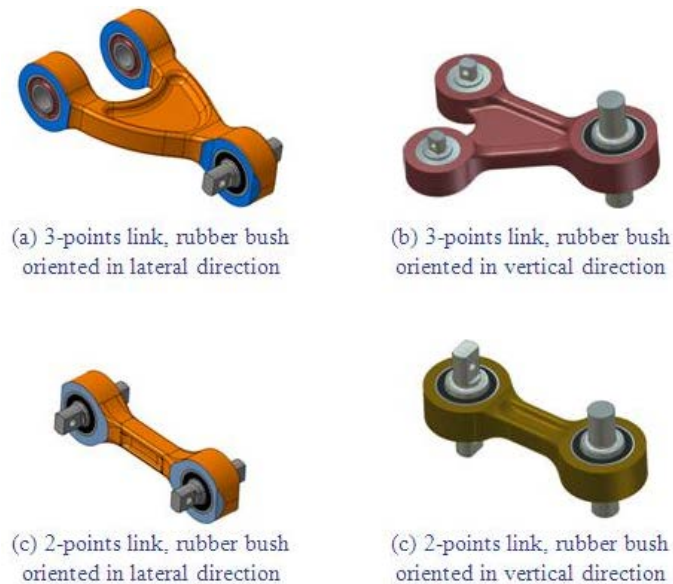

**Figure 2.1.3-g: Axle guiding device**

As noted previously, the axle guiding device is important for controlling the locomotive’s critical speed (hunting stability), which must be well above actual operating speed. The survey results show that except for the MBTA truck, which has a pedestal leg design, all other trucks have elastic axle guiding designs. Figure 2.1.3-g above illustrates three typical axle guiding designs. In Figure 2.1.3-g (a), the journal box is connected to the truck frame through a traction link. The traction link may have two different types: three-point link, such as Siemens SF1~SF4, or a two-point link, such as Bombardier Flexx Power trucks, as shown in Figure 2.1.3-h below. With proper selection of the bushings in the link, both three-point and two-point link designs can provide enough longitudinal and lateral guiding stiffness to meet both stability and curving performance requirements. This is especially true when a relatively soft stiffness of the rubber bushing, which still meets the straight track stability requirement, is chosen. Such soft elastic guiding can utilize the maximum self-steering properties of the tapered wheel profiles.

For an axle guiding design like that shown in Figure 2.1.3-g (b) (Alstom Prima locomotive truck - #8), the two-point link in Figure 2.1.3-h (c) below will be used. The guiding device in Figure 2.1.3-g (c) is integrated with the journal box—as is the case with the Ansaldo Breda truck. It is elastically connected to the truck frame by using a rubber bushing at one end.

The design life of the rubber bushing can be as long as 8 years or more. This makes such designs maintenance free within the design life.



**Figure 2.1.3-h: Traction links**

## Primary and secondary suspensions

For high-speed applications, the primary and secondary suspensions almost uniformly use coil springs (see Figures C.1a to C.1g in Appendix C). Coil springs will mainly provide stiffness in the vertical direction, but little stiffness in lateral and longitudinal directions. While the elastic axle guiding devices will mainly control the wheelset stability (hunting), the coil suspensions will mainly reduce and isolate the vibrations introduced by the track irregularities. The coil springs will provide large displacement (travel) of motions between axle and truck frame and between the truck and car body. Together with the necessary dampers, the design can provide good ride quality and passenger comfort.

The coils springs will provide relatively low yaw stiffness between the truck and the car body. This can benefit the curving performance and reduce track shift force and wheel wear.

Hydraulic dampers are used to provide damping for vibration control. Yaw and lateral dampers are used to control hunting.

An antiroll bar can be used to control the roll motion of the car body, but it is not used very often on locomotives. Among the surveyed trucks, there is only one truck design that uses the antiroll bar (see Talgo's truck design in Figure C.1f in Appendix C).

## Motor suspension

The three basic motor suspension methods utilized by the surveyed trucks are: (1) axle-hung (nose) suspension, (2) frame-hung (with drive train either partially suspended or fully suspended), and (3) body-hung suspension (drivetrain partially suspended).

Schematics of the three configurations are shown below in Figure 2.1.3-i:

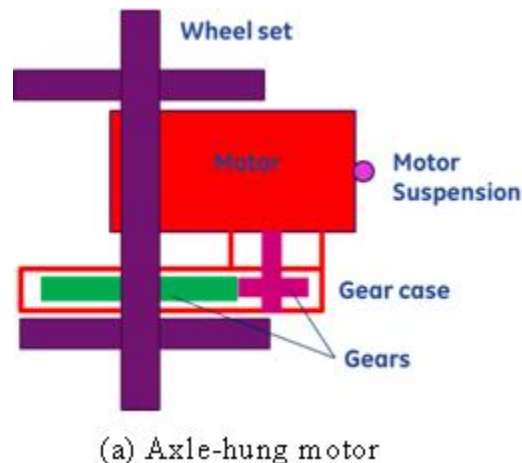

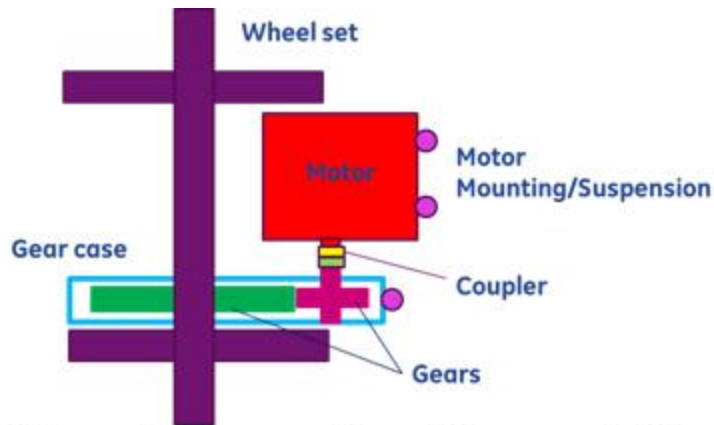

(b) Frame-hung motor with partially-suspended drive train

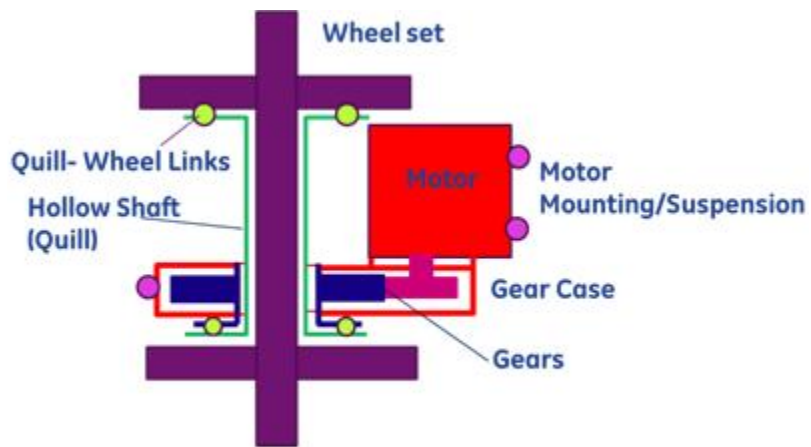

(c) Frame-hung motor with fully suspended drive train

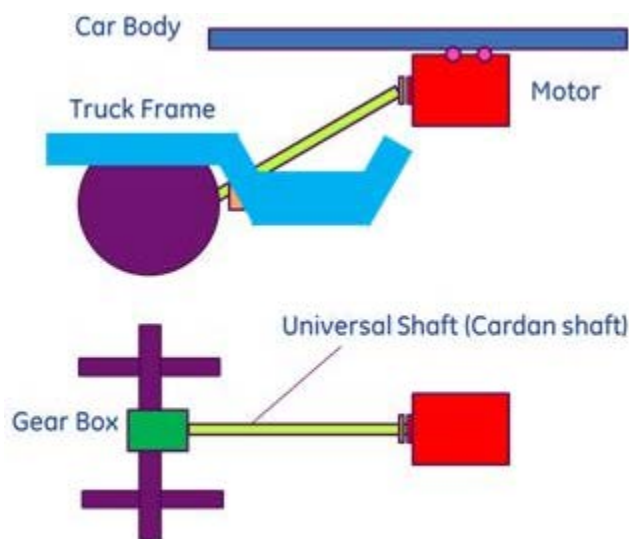

(d) Body-hung motor

**Figure 2.1.3-i: Motor suspensions**

Figure 2.1.3-j below shows the motor suspension methods of each of the surveyed manufacturers. For reference, the speed plot is repeated next to it. As indicated, for speeds above 140 km/h, all but one of the trucks outside the United States use either frame-hung or body-hung motor suspension. The only exception is the #9, Vossloh Euro 3000 AC truck which is designed for 200 kph (125 mph), but still uses an axle-hung motor suspension. The axle load for this design, 22 MT, is well below the U.S. application. In contrast, two of the three surveyed high-speed locomotives in the United States use axle-hung motor suspension; only one uses frame-hung motor suspension.

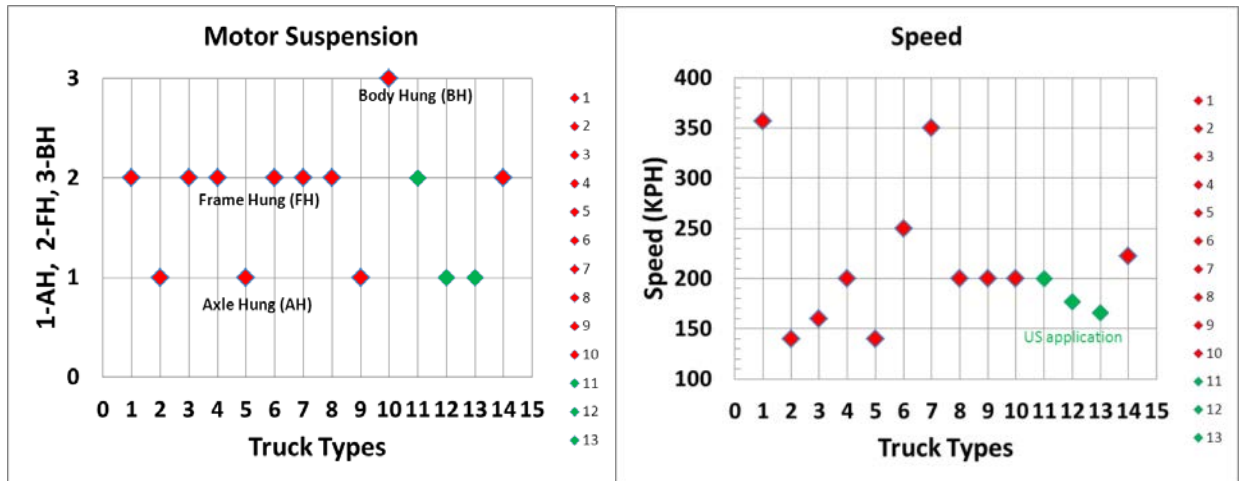

1	2	3	4	5	6	7	8	9	10	11	12	13	14
Siemens, SF1	Siemens, SF2	Siemens, SF3	Siemens, SF4	Bombardier, Flexx Power 140/200	Bombardier, Flexx power 250	Bombardier, Flexx power 350	Alstom, Prima II	Vossloh, Euro 3000AC	Talgo	Bombardier, ALP 45 DP	GE, Genesis	MPI/GE MBTA	Ansaldo Breda, E403

**Figure 2.1.3-j: Survey results of motor suspensions**

The unsprung mass has a large impact on the magnitude of the P2 force between the wheel and rail. For a given track structure, the P2 force will solely be a function of the locomotive weight (axle load), unsprung mass, and locomotive speed. As locomotive speeds increase, the locomotive weight or unsprung mass, or both, must be reduced to maintain the same P2 force. Figure 2.1.3-k below shows how, as speed increases, the locomotive weight and unsprung mass must be reduced to maintain a specified constant P2 force. If locomotive weight increases, unsprung mass must be significantly reduced to maintain the desired P2 force limit. In the case of Figure 2.1.3-k, the constant P2 limit is 82,000 pounds force (lbf) for the track structure specified by PRIIA.

Among the three types of motor suspensions shown in Figure 2.1.3-i, the axle-hung suspension will have the maximum unsprung mass for the same wheelset design and, for that reason, is normally used for lower speed applications, such as Siemens SF2, Bombardier Flexx Power 140, Vossloh Euro 3000 AC (Euro Light). The frame-hung suspension with fully suspended drivetrain, shown in Figure 2.1.3-i (c) (e.g., Siemens SF1 & SF4, Bombardier Power 250, and Ansaldo-Breda E403 locomotive truck), will provide the smallest unsprung mass. It is often used for very high-speed truck designs or the application of a very heavy locomotive running at higher speeds.



The configuration of frame-hung suspension with partially suspended drivetrain (as shown in Figure 2.1.3-i (b)) will have an unsprung mass between that of the axle-hung suspension and frame-hung suspension with fully suspended drivetrain (Siemens SF3, Bombardier Flexx Power 350, Alstom Prima II locomotive truck). Body-hung motor suspension in Figure 2.1.3-i (d) in which the motor is suspended on the carbody may not necessarily offer the minimum unsprung mass since the gear box on the axle mass adds to the unsprung mass.

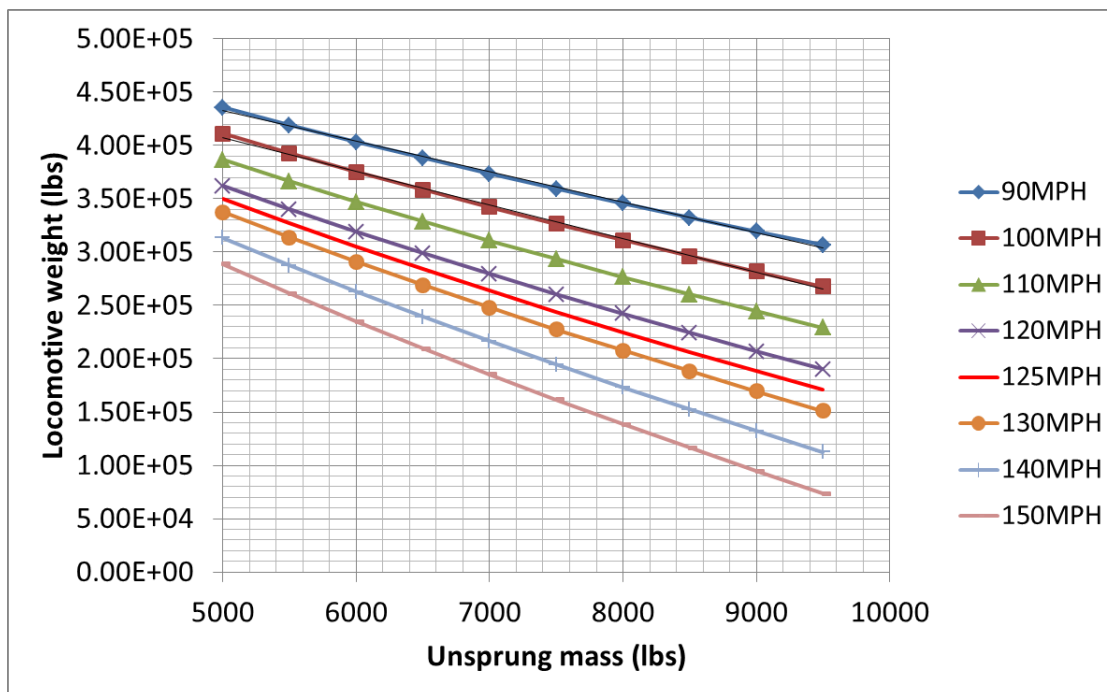

**Figure 2.1.3-k: Relation between unsprung mass and 4-axle locomotive weight for P2 force limit of 82,000 lb (track parameters are from PRIIA spec)**

### Brake design

Figure 2.1.3-l shows the survey results of air brake arrangements. For operation at speeds of 140 kph or higher, the majority of the truck designs, especially the trucks designed by European companies, use disc brakes. The two locomotives designed by U.S. companies are equipped with tread brakes alone. The trucks of New Jersey Transit’s (NJT) APL 45 DP locomotive designed by Bombardier are provided with both tread brake and disc brake.

There are two types of disc brake arrangements widely used: wheel mounted discs and axle mounted discs. As illustrated in Figure 2.1.3-m, wheel-mounted disc brakes are normally used for powered axles because of drivetrain arrangement and space requirement for packaging gear, gear case, and motor, among other things. Adding wheel-mounted disc brakes therefore increases the unsprung mass.

Axle-mounted disc brake arrangements have different variations. Figures 2.1.3-n through 2.1.3-p show three typical axle-mounted disc brake designs. For unpowered axles, like the application on an Electrified Multiple Unit (EMU) high-speed train, the design in Figure 2.1.3-n is commonly used. Depending on the requirement for the brake capability, multidiscs can be directly mounted on the axle. Again, such a design will increase the unsprung mass. To reduce the unsprung mass, a hollow shaft (quill) mounted disc brake arrangement was developed by



Bombardier for their fully suspended drivetrain design (Figure 2.1.3-o). Since the quill and the discs mounted on the quill need more space than just the axle itself, this will require a longer distance between the frame-hung motor and the axle. As a result, the gear transmission may need “idlers” in the gear case, which may require an increase in wheel base length.

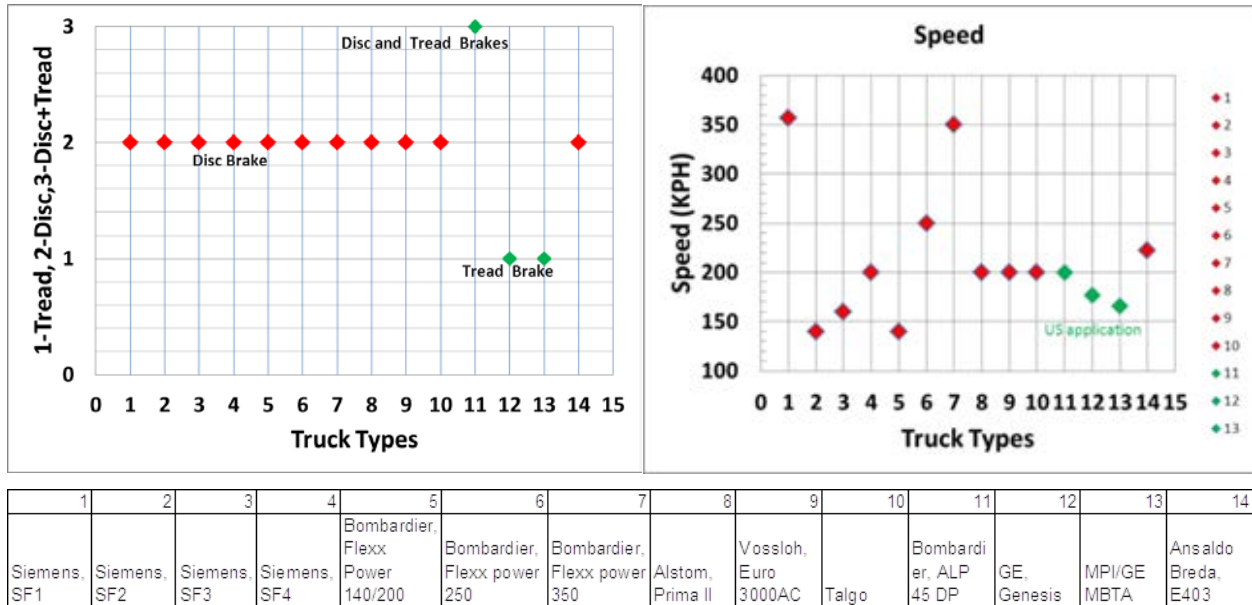

Figure 2.1.3-l: Brake arrangements

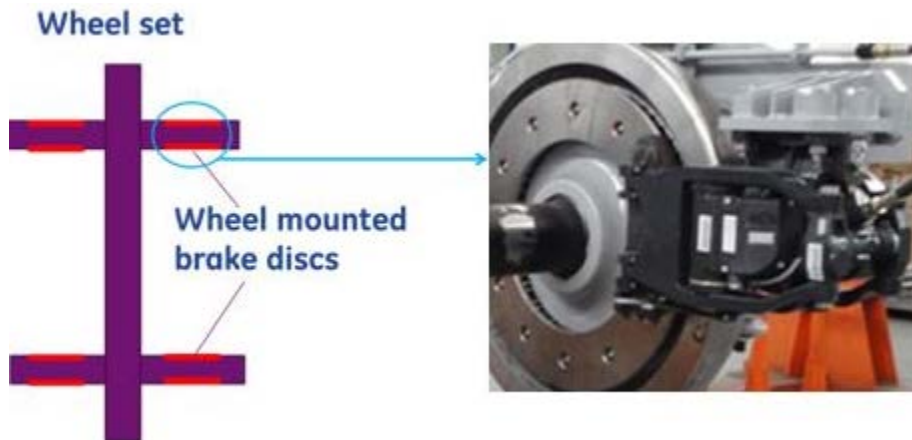

Figure 2.1.3-m: Wheel-mounted disc brake

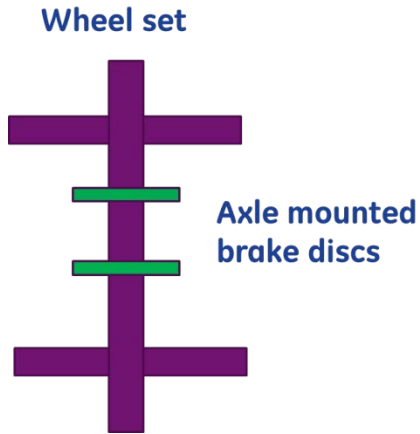

Figure 2.1.3-n: Axle mounted disc brake

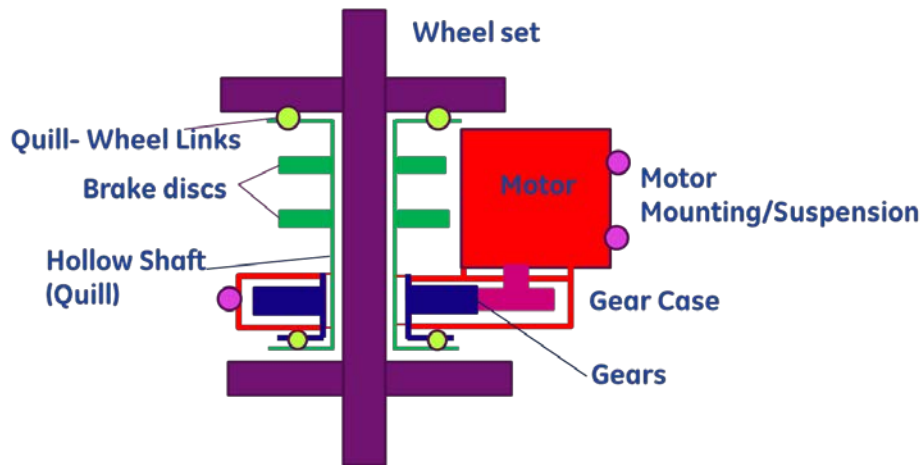

Figure 2.1.3-o: Hollow-shaft (quill) mounted disc brake (Bombardier ALP45 DP)

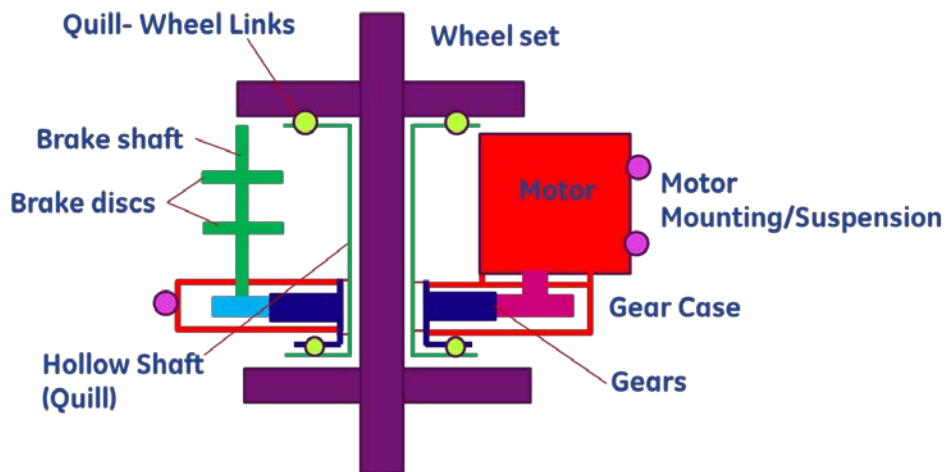

Figure 2.1.3-p: Discs mounted on separate shaft (Siemens SF1)

Another variation of the axle-mounted disc brake arrangement, intended to reduce the unsprung mass, is the Siemens SF1 truck design. In this design, a separate shaft mounted with brake discs is driven through the drivetrain, as shown in Figure 2.1.3-p. The separate shaft is mounted on the frame, and the overall drivetrain is fully suspended. Compared with the Bombardier design in Figure 2.1.3-o, this arrangement may have the advantage of somewhat reducing the wheelbase.

The combination of tread and disc brakes may be a tradeoff between brake capacity, design complexity, and wheel reliability. Tread brake can be used as a supplement to the disc brake within the thermal capability of the wheel. Periodic application of the tread brake can clean the wheel tread to improve adhesion.

### **Secondary Traction Links**

The connection in longitudinal direction between truck frame and car body will transmit tractive and brake efforts. Its design and location may impact the truck configuration, wheel base, and some of the performance traits, especially weight transfer. Although a lot of today's locomotives use individual axle control and can maximize the utilization of the transferred weight, it is still good practice to reduce the weight transfer as much as possible, especially for locomotives with truck control for traction. Therefore, a good practice is to make the "traction point" as low as possible (as close as possible to the rail top).

In addition to providing force transmission in the longitudinal direction, the connection between the truck and car body should provide enough flexibility for lateral, vertical, and rotational motions.

Figure 2.1.3-q shows several typical traction connections between truck and car body. The center pivot (or traction pin) design in Figure 2.1.3-q (a) is a conventional design and is still used very commonly in many applications like the Siemens SF series truck and the Vossloh truck because of its simplicity. The center pin in this application does not take any vertical load. The pin can move freely in the lateral direction, relative to the truck frame, until the lateral bump stops are encountered.

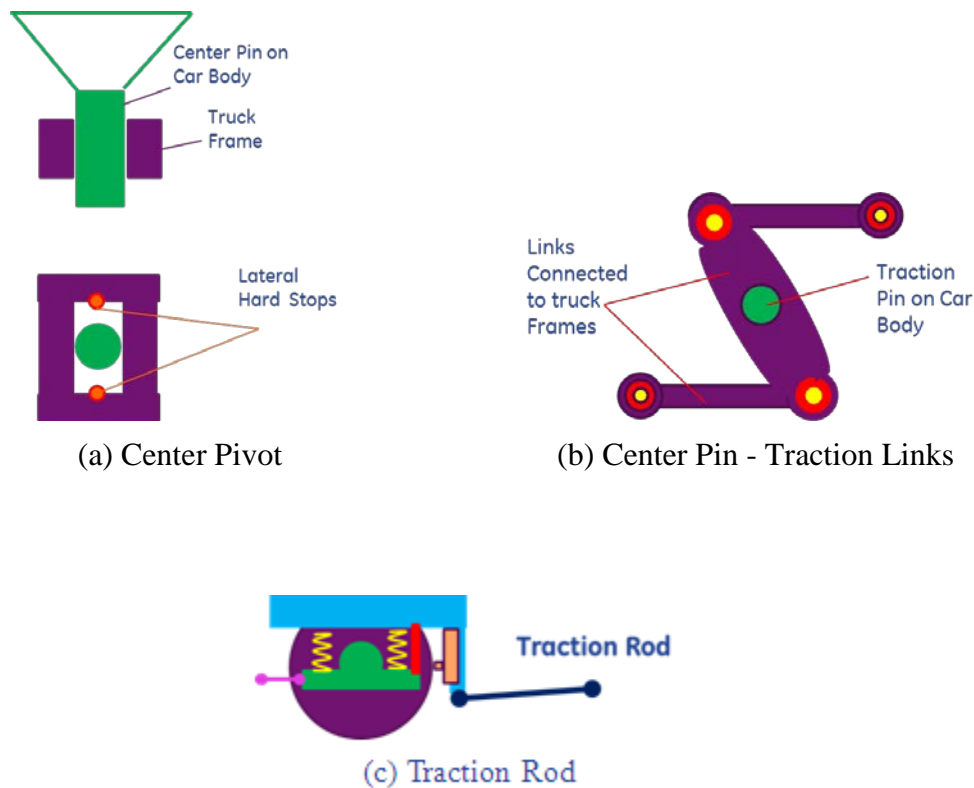

**Figure 2.1.3-q: Truck/Body traction connections**

The combination of traction pin and traction links, shown in Figure 2.1.3-q (b), is another type of widely used connection. The “Z” type arrangements of the links provide the necessary compliance in lateral direction. The application of the rubber bushings between the links avoids wear and is maintenance free. The traction rod design in Figure 2.1.3-q (c) is very commonly used on trucks produced by Bombardier, Alstom, Talgo and Ansaldo. The traction point of this configuration can be much lower and close to the rail top. For application on a diesel locomotive, special consideration should be given to the arrangement of the traction rod in order to avoid interference with the fuel tank.

#### **2.1.4 Conclusions and Recommendations**

##### **Conclusions**

The primary design characteristics of the high-speed trucks surveyed are focused on two general areas:

- 1) Reducing unsprung mass and total weight in order to minimize P2 forces
- 2) Optimizing stability, curving performance, and ride quality

The following list summarizes the **dominant design trends** of the high-speed trucks surveyed:

- **Two axle truck with Bo-Bo arrangement** for high stability and curving performance. Wheel base is typically between 2.6~3 meters, and the wheel diameter ranges from 1.01~1.25 meters.

- **Fabricated truck frame** for light weight and manufacturability (1 truck had a cast frame)
- **Frame-hung motor suspension** with either partially suspended drivetrain or fully suspended drivetrain to reduce unsprung mass (and therefore reduce P2 force). For fully suspended drivetrain design, quill (hollow shaft) design is most common.
- **Disc brakes or combination of disc and tread brakes** to increase brake capacity and reduce possible damage to the wheels. Wheel mounted discs are very commonly used. But to further reduce unsprung mass, suspended quill mounted discs or separate axle mounted discs are used.
- **Elastic connections (rubber bushings)** between journal box and truck frame for better axle guiding performance to increase locomotive hunting stability and curving performance
- **Coil springs for both primary and secondary suspensions** for optimum ride quality and comfort
- **Center pivot or end traction rod for secondary link** (connection between truck and carbody)
- **Application of active yaw control** to improve curving performance
- **Low axle loading** to reduce P2 force—all but one of the nonUS surveyed locomotives have an axle load of 22 MT or lower. The only exception is the Bombardier Flex 250 designed for U.S. application that has an axle load of 32.6 MT.
- **Solid axle for locomotive applications**

## Recommendations

### Impact of high axle loads

The high axle loads of 30–33 MT or higher for the U.S. high-speed truck will make meeting the P2 force limit extremely challenging and will drive a number of design changes. What works well in the overseas applications may not be adequate for the heavier U.S. applications. Wheel-mounted disc brake and partially suspended drivetrain, for example, will likely not be adequate in the United States. Some preliminary analysis, discussed later in more detail, indicates that a fully suspended drivetrain, as well as combined disc and tread brake systems, will be necessary for the U.S. design.

### Impact of U.S. track conditions

The suspension systems in the existing foreign locomotive trucks will have to be designed differently for U.S. track conditions. The dynamic loads experienced by the truck and components due to track excitations are very different, necessitating a different design duty cycle/load spectrum than that used for truck design in other countries. The truck structure and components for the U.S. design will also have to be designed differently. In short, there may be no existing truck designs from other countries that meet the performance requirement, reliability and life requirements, and safety requirements for operation on U.S. track. This has been demonstrated in past experience and tests. Developing new high-speed trucks for the PRIIA specified U.S. application will require leveraging both existing technology and new innovations.

### **Proposed design concepts**

Due to the extreme axle load requirement for truck design to reach speeds of up to 125 mph, the following two concept examples are considered the most promising options:

#### Concept 1

- Two axle truck with Bo-Bo arrangement – stability and curving performance
- Fabricated truck frame – weight
- Frame-hung motor with fully suspended drivetrain – unsprung mass
- Combination of disc and tread brakes by using either quill mounted discs or separate disc axle

#### Concept 2

- Three-axle truck with A1A arrangement
- Frabricated truck frame
- Frame-hung motor with fully suspended drivetrain
- Combination of disc and tread brakes by mounting discs on center axle

Concept 1, with only four axles per locomotive, still faces the challenge of high axle load. To meet the P2 requirement, the fully suspended drivetrain design and the arrangement of the disc brake are critical. Both will increase the complexity of the component design and packaging requirements.

Concept 2 reduces axle load by distributing weight over six axles rather than four. The center axle can be used for axle mounted disc brakes. This may lead to a simpler drivetrain system design due to the decreased demand of brakes on the quill. A disadvantage may be that the overall truck wheel base will be larger than the base for the Concept 1 design.

### **Configuration for Task 2 modeling**

Concept 1 was chosen as the preferred concept for U.S. application. This concept was chosen for the modeling analysis described in Task 2, which is described in more specific detail in the next section. Four-axle locomotives with frame-hung traction motors are the dominant and proven trend in passenger locomotives. It is believed that this concept is likely to be the most successful technology and also the most commercially viable concept for the next generation passenger locomotive.

## **2.2 Task 2—HSR Bogie Running Stability Summary Report**

### **2.2.1 Definition**

The design of the suspension system will critically impact the safety related locomotive/truck dynamic performance in the areas of stability, derailment safety (curving), dynamic wheel-rail forces, ride quality, and dynamic loads on the truck components. The purpose of Task 2 is to use the selected truck design concept to study and analyze the effects of truck suspension system on truck dynamics performance under U.S. track conditions.

### **2.2.2 Approach**

For the analysis, the following approaches were taken:

- Develop a truck and locomotive dynamics model in ADAMS/Rail by using the truck concept with frame-hung motor as proposed in Task 1
- Use track conditions as specified in MCAT (Minimally Compliant Analytical Track) for dynamic simulations on straight and curved tracks
- Consider both new and worn wheel and rail conditions
- Investigate impact and effects of suspension parameters on safety related performances by using Design of Experiments (DOE) and response surface method
- Determine feasible design space of suspension parameters to meet allowable safety limits of dynamic performances

### **Truck/Locomotive Dynamics Model**

The dynamic analysis for this task was conducted using ADAMS/Rail, an advanced program specifically developed to model and analyze railway vehicle dynamics.

The truck model developed for this analysis is based on the truck design Concept 1 described at the end of the previous section (Task 1). It is shown in Figure 2.2.2-a below. It consists of frame-hung motor, fully suspended drivetrain (quill drive), three-point traction link with rubber bushings for axle guidance, primary and secondary coil springs, primary vertical dampers, secondary lateral, vertical and yaw dampers, as well as a center pin design for the connection between truck and car body. The locomotive is assumed to weigh 282,000 lb. The truck center pin distance is 510.6 in (12.97 m) and wheel base is 118.26 in (3 m). The new wheel diameter was set at 40 in. With the frame-hung motor and fully suspended drivetrain, the unsprung mass is 6,733 lb.

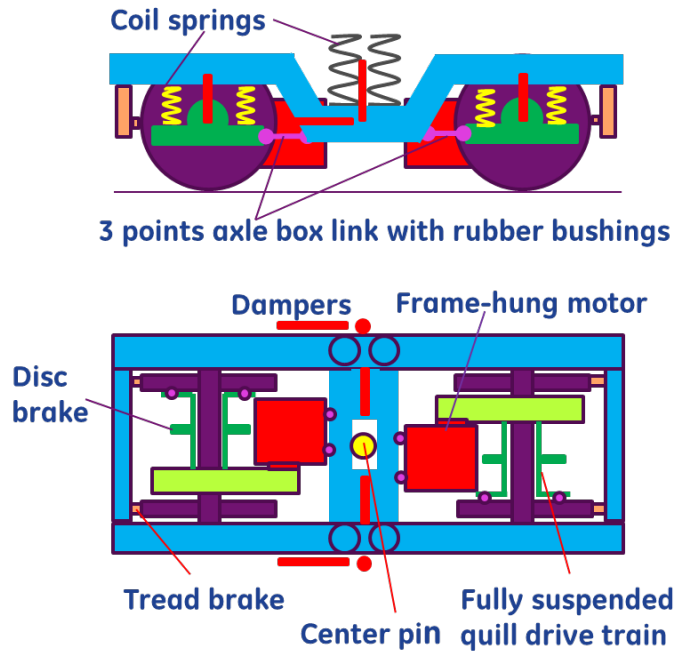

**Figure 2.2.2-a: High-speed truck used for Task 2 analysis: frame-hung motor and fully suspended drivetrain**

Figure 2.2.2-b below shows the ADAMS models of the truck and locomotive. The locomotive model is a multibody dynamic system model. It includes 109 “parts” (bodies) and has 486 degrees of freedom. The primary and secondary suspension systems are modeled as linear. The motor suspension and the quill suspension are modeled as rubber parts with nonlinear characteristics. Necessary hard stops in both primary and secondary connections are built in by using either impact or bistop functions. The traction motor is modeled with a stator and rotor. Gear elements are used to simulate the torque and motion transmission between the rotor and wheelset.



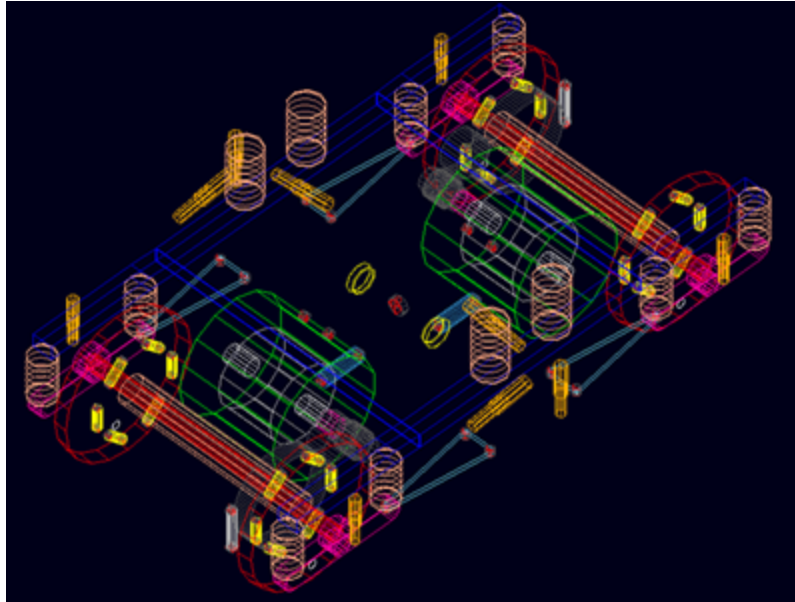

(a) Truck Model in ADAMS/Rail

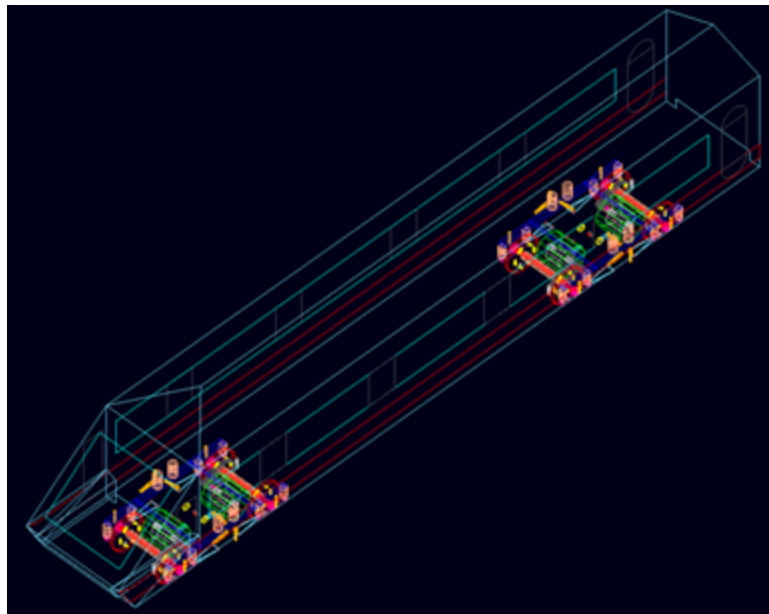

(b) Locomotive Model in ADAMS/Rail

**Figure 2.2.2-b: ADAMS/Rail Models for dynamic analysis**

### **Track Inputs**

The dynamic responses of the locomotive are functions of the track inputs. For the purposes of this study's analysis, the track conditions specified in Appendix D of CFR 49 Part 213 (MCAT Simulations Used for Qualifying Vehicles to Operate at High-Speeds and at High Cant Deficiencies) were used. MCAT specifies a track model containing defined geometry perturbations at the limits permitted for a class of track and level of cant deficiency, as shown in Figure 2.2.2-c. Class 7 track, with a disturbance wavelength of 62 feet (ft), was chosen for the simulations on both straight and curved tracks. The corresponding parameters of the MCAT

track setup are shown in Table 2.2.2-a and 2.2.2-b. The track configuration for the curving analysis is detailed in Table 2.2.2-c, where a 1.1-degree curve with a super-elevation of 6 in is used. A running speed of 125 mph is used for the analysis on both straight and curved tracks. This speed will create a 6-inch cant deficiency for the selected 1.1-degree curve.

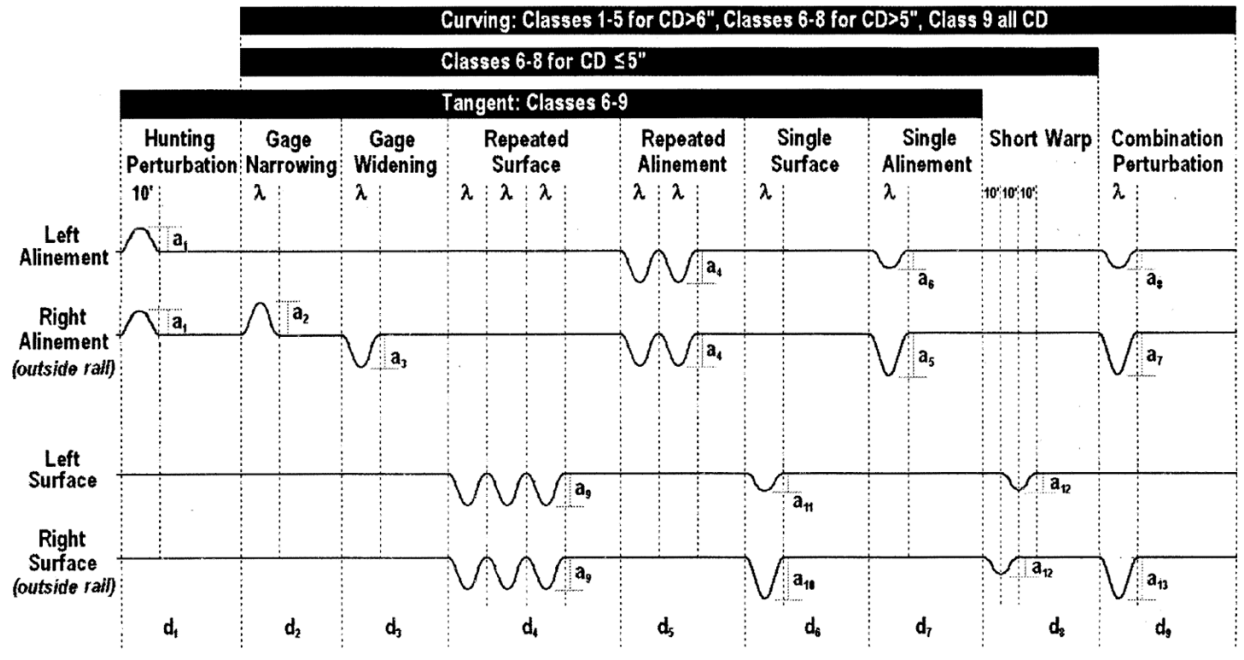

Figure 2.2.2-c: MCAT track definition for simulations

Table 2.2.2-a: MCAT geometry, tangent track, Class 7 track

MCAT Tangent, Class 7								
Disturbance segments	Disturbance Amplitude a			Wave Length $\lambda$		Segment length d		
		in	m	in	m		ft	m
Hunting Perturbation	a1	0.5	0.0127	10	3.048	d1	1000	304.8
Gage Narrowing	a2	0.5	0.0127	62	18.8976	d2	1000	304.8
Gage Widening	a3	0.5	0.0127	62	18.8976	d3	1000	304.8
Repeated Surface	a9	0.75	0.01905	62	18.8976	d4	1500	457.2
Repeated Alinement	a4	0.375	0.009525	62	18.8976	d5	1000	304.8
Single Surface	a11	0	0	62	18.8976	d6	1000	304.8
	a10	1	0.0254	62	18.8976			
Single Alinement	a6	0.25	0.00635	62	18.8976	d7	1000	304.8
	a5	0.75	0.01905	62	18.8976			

**Table 2.2.2-b: MCAT geometry, curved track, Class 7, CD = 6 in**

MCAT Curving, Class 7, CD=6 inches								
Disturbance segments	Disturbance Amplitude a			Wave Length $\lambda$		Segment length d		
		in	m	in	m		ft	m
Hunting Perturbation	a1	0	0	10	3.048	d1	1000	304.8
Gage Narrowing	a2	0.5	0.0127	62	18.8976	d2	1000	304.8
Gage Widening	a3	0.5	0.0127	62	18.8976	d3	1000	304.8
Repeated Surface	a9	0.75	0.01905	62	18.8976	d4	1500	457.2
Repeated Alinement	a4	0.375	0.009525	62	18.8976	d5	1000	304.8
Single Surface	a11	0	0	62	18.8976	d6	1000	304.8
	a10	1	0.0254	62	18.8976			
Single Alinement	a6	0	0	62	18.8976	d7	1000	304.8
	a5	0.5	0.0127	62	18.8976			
Short Wrap	a12	0.5	0.0127	62	18.8976	d8	1000	304.8
Combination Perturbat	a7	0.333	0.0084582	62	18.8976	d9	1000	304.8
	a8	0	0	62	18.8976			
	a13	0.667	0.0169418	62	18.8976			

**Table 2.2.2-c: Configuration of curved track**

Track Distance	Curvature	Superelevation	Speed
(ft)	(degree)	(in)	(miles/h)
0	0.0	0	125
917	0.0	0	125
<b>1022</b>	<b>1.1</b>	<b>6</b>	<b>125</b>
<b>11423</b>	<b>1.1</b>	<b>6</b>	<b>125</b>
11528	0.0	0	125
26247	0.0	0	125

**Wheel and Rail Profiles**

The combination of the wheel and rail profiles will significantly impact the running stability and dynamic response of the locomotive. To understand the influence of possible variations of the wheel-rail profile during the normal operation, the following typical wheel and rail profiles are used for the wheel-rail contact geometry calculation:

**Table 2.2.2-d: Wheel and rail profile specification**

	New	Worn
<b>Wheel</b>	Amtrak Standard	Measured
<b>Rail</b>	AREMA136	Measured on straight track
		Measured on curved track

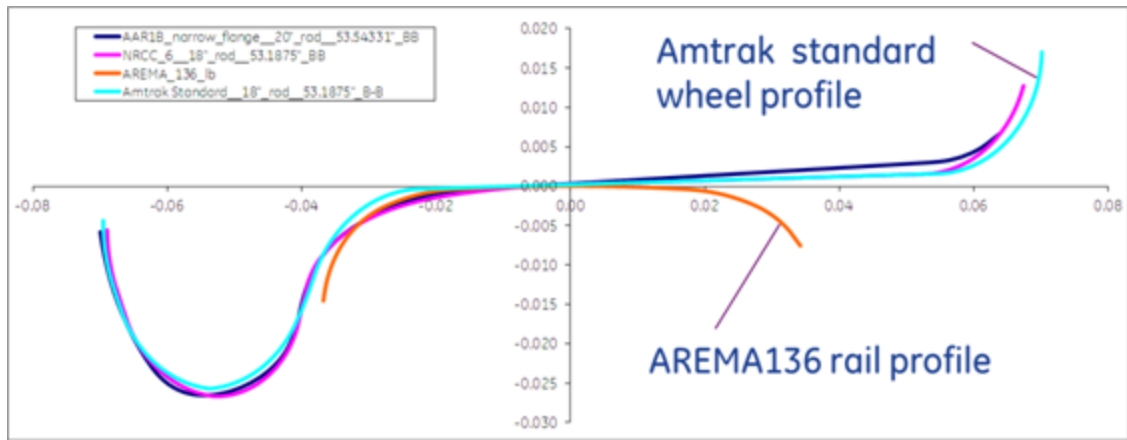

(a) Amtrak standard wheel profile and AREMA136 rail profile

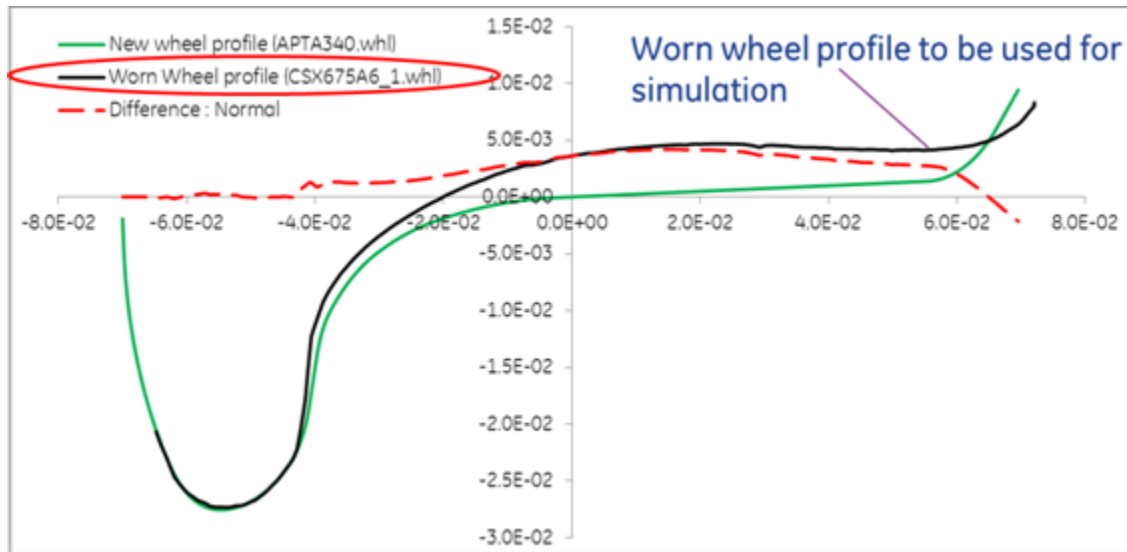

(b) Measured worn wheel profile

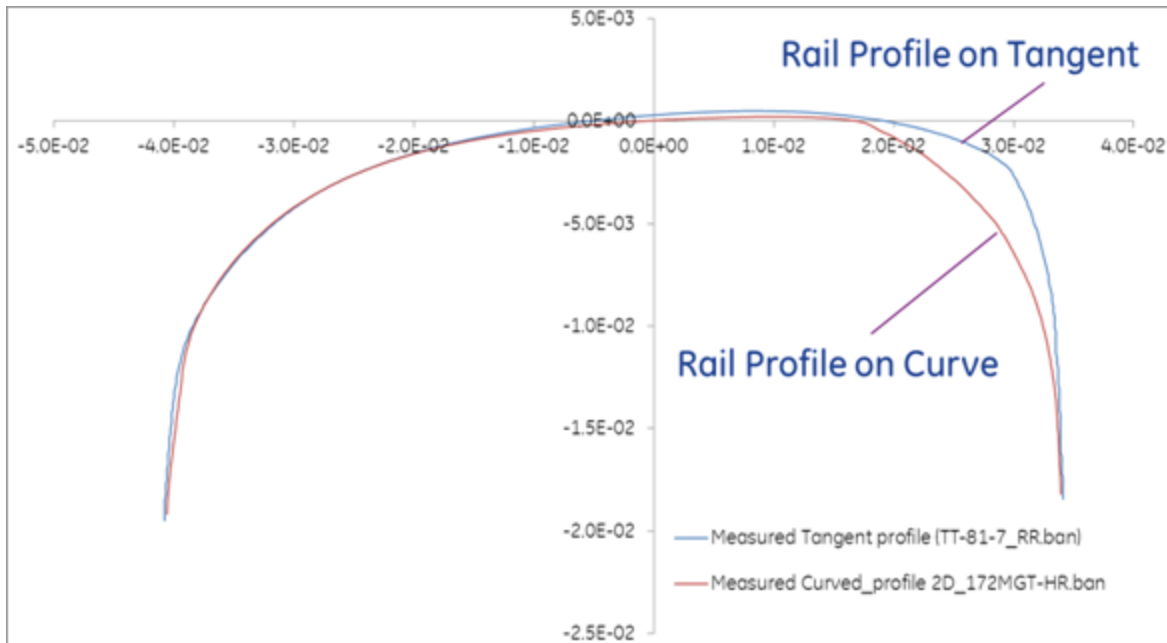

(c) Measured rail profiles on straight and curved tracks (Provided by Michael Trosino at Amtrak)

**Figure 2.2.2-d: Wheel and rail profiles used for the simulations**

### Wheel-Rail Contact Geometry

The calculation of wheel-rail contact geometry determines the following contact parameters as a function of wheelset motions: contact patch location, contact patch dimensions, rolling radius at contact patch, and contact angles at contact patch. These contact parameters are used to determine the normal and tangential (creep) forces, based on rolling contact mechanics between the wheel and rail.

Another important contact geometry parameter is the equivalent conicity which is important for determining the truck hunting speed (critical speed). Larger equivalent conicity may cause lower critical speed.

Different wheel-rail profile combinations will result in different contact parameter functions. They will have different impacts on the kinematics and mechanics between the wheel and rail. Therefore, they will have different effects on the locomotive running performances.

For the contact geometry calculation, the following parameters were used: a standard gauge of 56.5 in, rail inclination of 1/40, wheel back-to-back distance of 53.188 in, wheel diameter of 40 in, and wheel flange angle of 75 degrees.

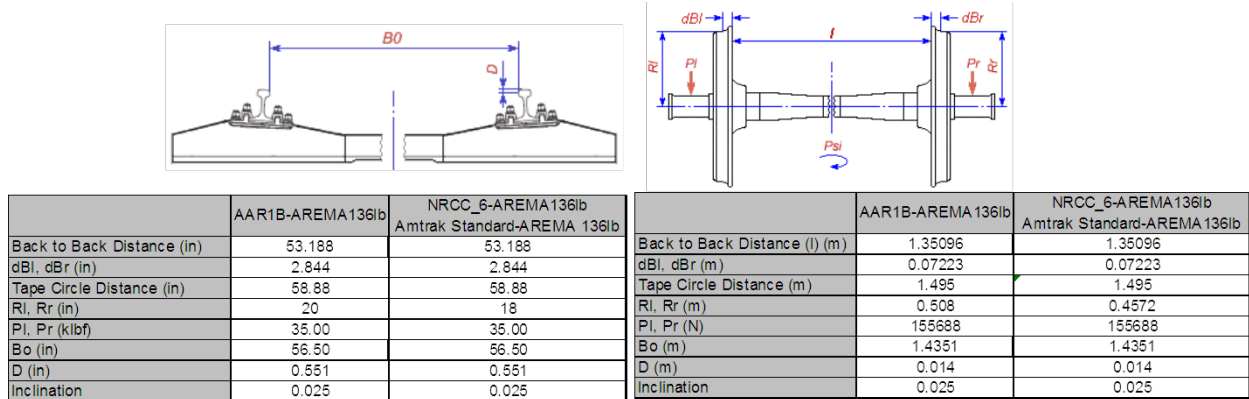
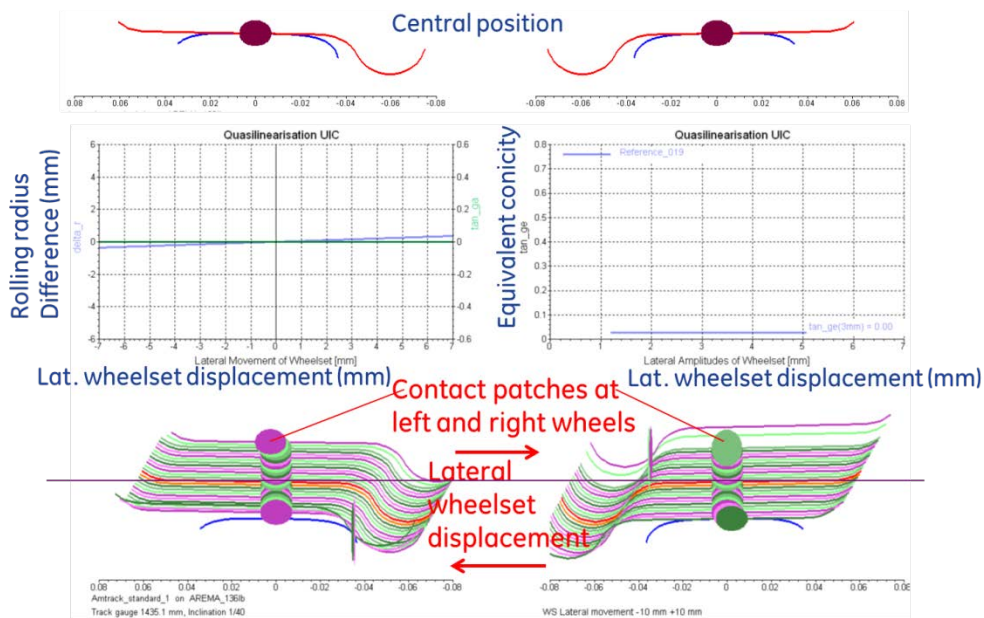

**Figure 2.2.2-e: Parameter definition for contact geometry calculation**

### Contact geometry results

Figures 2.2.2-f through 2.2.2-j show some of the results of the contact geometry calculations. Note that, in general, the contact geometry is nonlinear. This is especially true for worn wheel-rail profile combinations where the contact geometry parameters are highly nonlinear functions of the wheelset lateral displacement (see Figure 2.2.2-i and Figure 2.2.2-j). In order to accurately capture the nonlinear characteristics, a generalized nonlinear wheel-rail contact geometry module must be used for the dynamic simulations.

### Wheel/Rail Contact Geometry - Amtrak Standard-AREMA136lb



**Figure 2.2.2-f: Contact geometry of new Amtrak standard wheel profile and new AREMA136 rail profile**

Wheel/Rail Contact Geometry: New Amtrak wheel & worn tangent rail

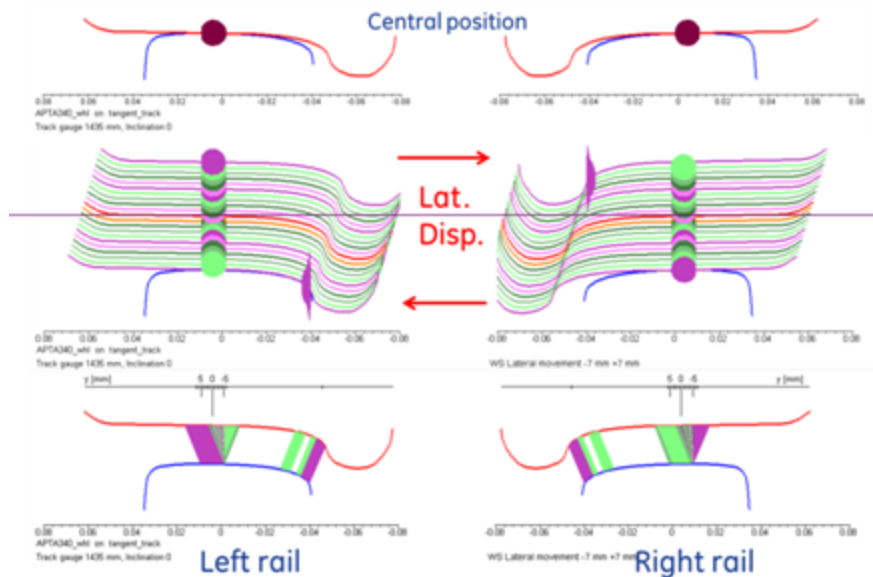

(a) Contact patch locations vs. lateral wheelset displacement

Wheel/Rail Contact Geometry: New Amtrak wheel & worn tangent rail

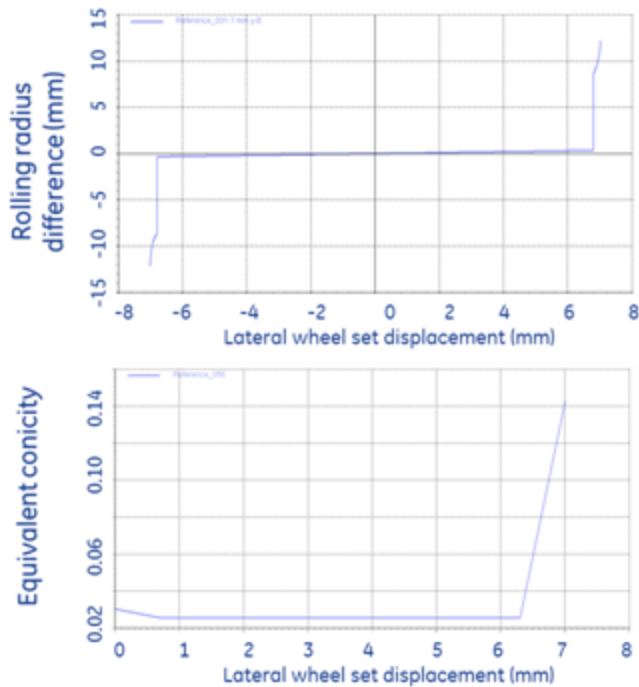

(b) Contact rolling difference and quasi-linearized equivalent conicity

**Figure 2.2.2-g: Contact geometry of new Amtrak standard wheel profile and worn rail profile on straight track**



### Wheel/Rail Contact Geometry: New Amtrak wheel & worn curve rail

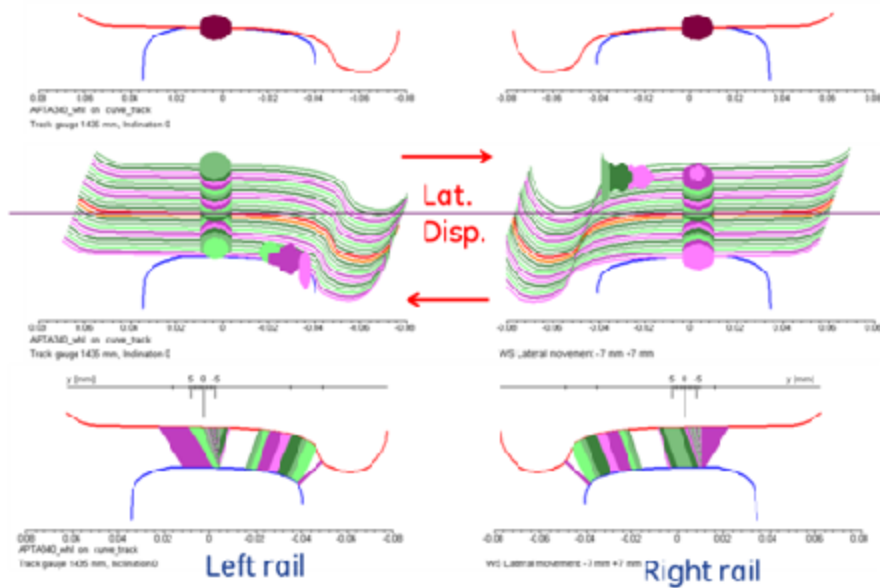

(a) Contact patch locations vs. lateral wheelset displacement

### Wheel/Rail Contact Geometry: New Amtrak wheel & worn curve rail

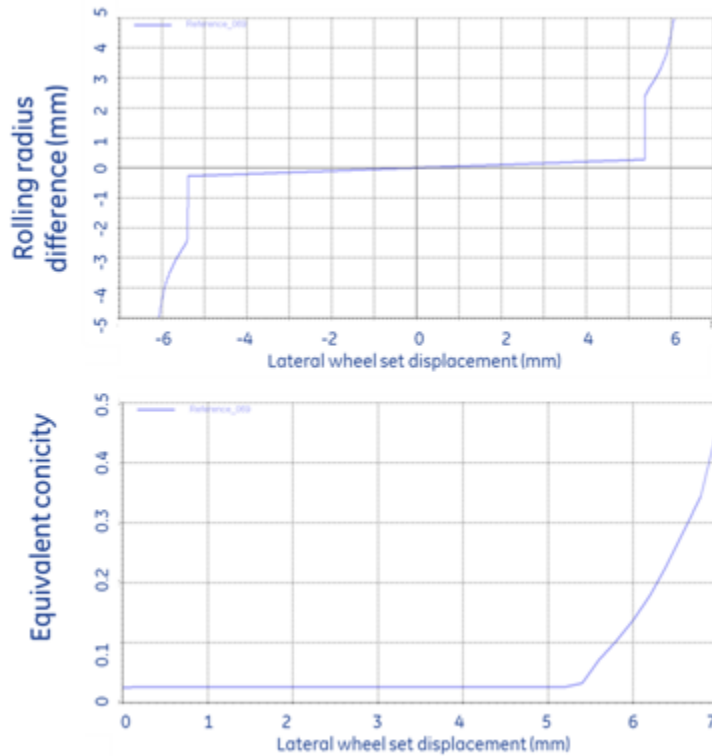

(b) Contact rolling difference and quasi-linearized equivalent conicity

**Figure 2.2.2-h: Contact geometry of new Amtrak standard wheel profile and worn rail profile on curved track**



### Wheel/Rail contact geometry - Worn wheel & worn tangent rail

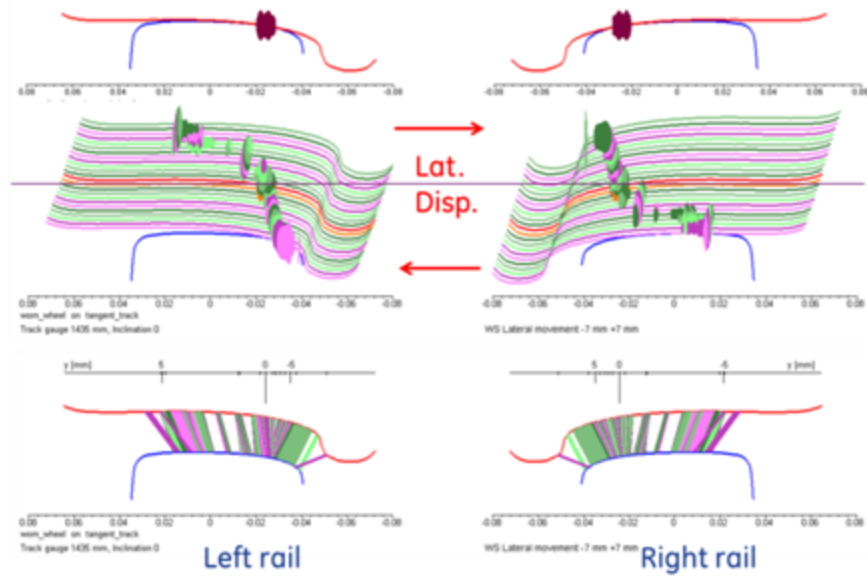

(a) Contact patch locations vs. lateral wheelset displacement

### Wheel/Rail Contact Geometry - Worn wheel & worn curve rail

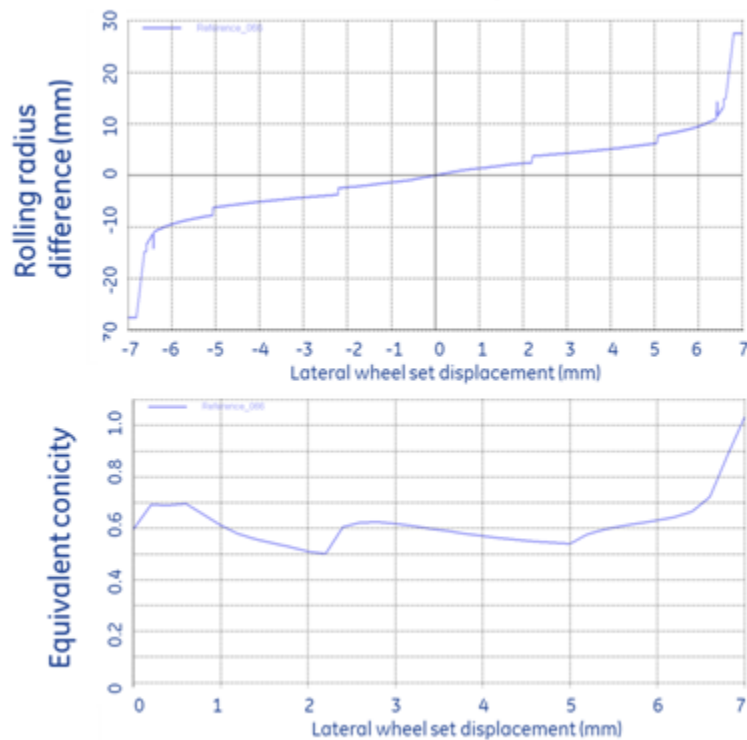

(b) Contact rolling difference and quasi-linearized equivalent conicity

**Figure 2.2.2-i: Contact geometry of worn wheel profile and worn rail profile on straight track**

### Wheel/Rail Contact Geometry - Worn wheel & worn curve rail

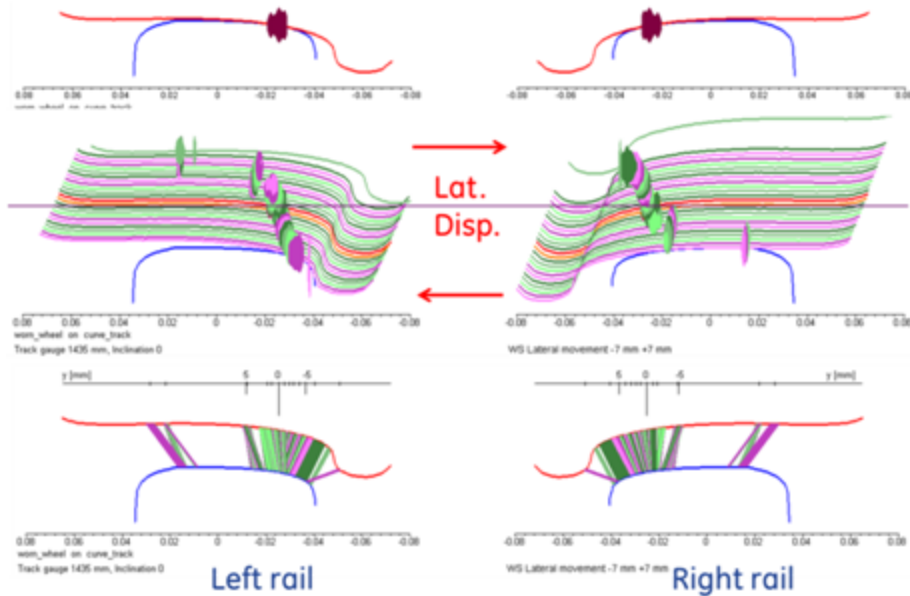

(a) Contact patch locations vs. lateral wheelset displacement

### Wheel/Rail Contact Geometry - Worn wheel & worn curve rail

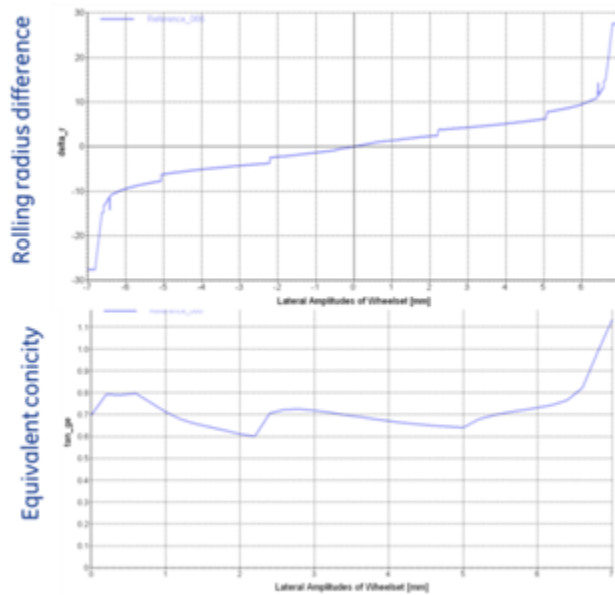

(b) Contact rolling difference and quasi-linearized equivalent conicity

**Figure 2.2.2-j: Contact geometry of worn wheel profile and worn rail profile on curved track**

### Wheel-Rail Contact Mechanics

To describe the forces generated between the wheel and rail, the nonlinear rolling contact mechanics method was used. The creepage-creep force relations were determined by using Kalker theory. For calculation of the creep forces, a friction coefficient of 0.5 was used between the wheel and rail.

### Simulation of Design of Experiments (DOE) and Response Surface

A DOE simulation and response surface analysis is used to understand the sensitivity of the locomotive running performances to the suspension parameters and identify the critical design parameters for high-speed truck design. The regression functions of the response surfaces can be used for selection of design parameters and performance optimization.

### Design variables of DOE

To study the impact of the suspension parameters on the performances of the selected truck concept, a simulation DOE was used to find the response “surfaces”—performances as functions of the characteristic parameters of the suspension system. Table 2.2.2-e below lists the 10 major suspension parameters selected as design variables for the DOE study. Figure 2.2.2-k shows where these parameters are located on the truck.

**Table 2.2.2-e: 10 Major Design Variables for Modeling**

Parameters	Variable	Comment
Primary Suspension—vertical stiffness/spring	PS_Vert	2 per journal box
Primary Suspension—lateral stiffness/spring	PS_Lat	2 per journal box
Primary Suspension—vertical damping/damper	Pri_Damp	1 per journal box
Secondary Suspension—vertical stiffness/spring	SS_Vert	2 per truck side
Secondary Suspension—lateral stiffness/spring	SS_Lat	2 per truck side
Secondary Suspension—vertical damping/damper	Ver_Damp	1 per truck side
Secondary Suspension—lateral damping/damper	Lat_Damp	1 per truck side
Secondary Suspension—longitudinal (yaw) damping/damper	Long_Damp	1 per truck side
Traction link radial lateral & longitudinal stiffness/bushing	Rad_Bush	3 per link (journal box)
Traction link cocking stiffness/bushing	Cock_Bush	3 per link (journal box)

The lateral stiffness of a coil spring can be determined by using a relation to its vertical stiffness. To simplify the DOE analysis, the lateral stiffness of the primary and secondary coil springs in Table 2.2.2 (see also Figure 2.2.2-k) was determined by

$$PS\_Lat = \alpha_p * PS\_Vert$$

$$SS\_Lat = \alpha_s * SS\_Vert$$

Thus, the independent design parameters for the DOE in the above table can be reduced to eight.

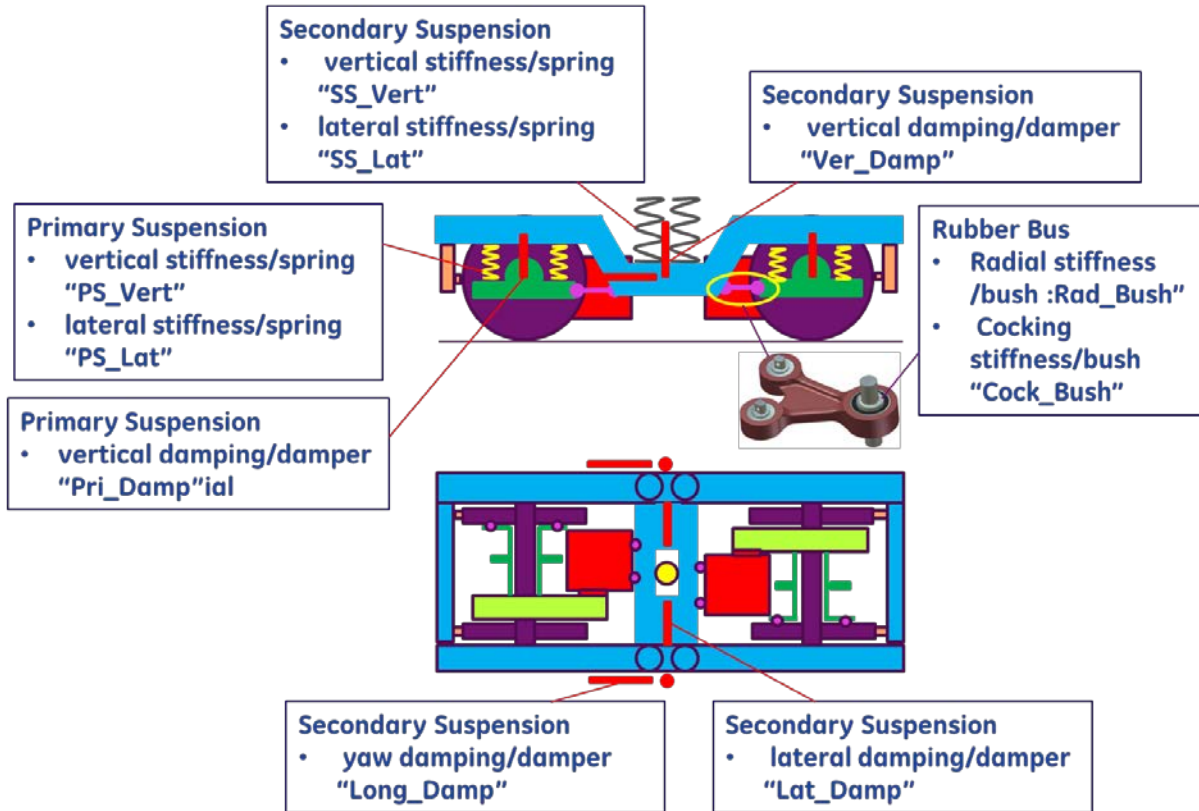

Figure 2.2.2-k: Parameters to be used for DOE analysis

### MCAT performance parameters used as responses

Table 2.2.2-f lists the nine major performance parameters along with their specified limit values.

**Table 2.2.2-f: MCAT Performance Parameters**

Performance parameter	Limit	Comment
Wheel load reduction rate $dQ/Q$ *	$\leq 0.85$	MCAT: $\frac{V}{V_0} \geq 0.15$ $dQ = V_0 - V, Q = V_0$
Wheel L/V *	$\leq 1.13$	$= \frac{\tan(\delta)-0.5}{1+0.5 \tan(\delta)}, \delta = 75^\circ$
Net Axle Lateral Force *	$\leq 0.47$ kips	$= 0.4 + 5/V_a$ with $V_a$ = static axle load
Truck side L/V	$\leq 0.60$	
Car Body Lateral Acceleration ** – Transient: peak-to-peak *	$\leq 0.75$ g	for locomotive
Car body lateral Acceleration ** – Sustained: RMS	$\leq 0.12$ g	for locomotive
Car Body Vertical Acceleration ** – Transient: peak-to-peak *	$\leq 1.0$ g	
Car body Vertical Acceleration ** – Sustained: RMS	$\leq 0.25$ g	
Truck frame lateral Acceleration *** – RMS *	$\leq 0.30$ g	

Notes:

\*: These performances will be used as objectives during optimization.

\*\* : The accelerometers shall be placed on the floor of the vehicle as near the center of a truck as practicable.

\*\* The accelerometer shall be mounted on a truck frame at a longitudinal location as close as practicable to an axle's centerline (either outside axle for trucks containing more than two axles), or, if approved by FRA, at an alternate location.

To simplify the DOE simulations, the list above was reduced to the following six critical performance parameters to build the response surface:

- Max. wheel load reduction rate  $dQ/Q$  of leading axle
- Max. wheel L/V of leading axle
- Net axle lateral force of leading axle
- Car body lateral acceleration—transient peak to peak
- Car body vertical acceleration—transient peak to peak
- Truck frame lateral acceleration—transient peak to peak

Three parameters in Table 2.2.2-f were not included in the simulations. They are:

- Truck side L/V
- Car body lateral acceleration \*\*—Sustained: RMS
- Car body vertical acceleration \*\*—Sustained: RMS

These parameters are related to three other selected parameters: maximum wheel L/V of leading axle, car body lateral acceleration (transient peak to peak), and body vertical acceleration (transient peak to peak). After the suspension parameters are finalized, the three performance parameters not included can be confirmed against the specified limits to make sure these performances also meet the requirement.

### DOE Design

For the DOE design, GE DFSS (Design for Six Sigma) III 6-sigma optimization tools were used. In order to capture the nonlinear relations between the responses (performances) and the suspension parameters, a third-order response surface model was used. The DOE was determined by using the face-centered CCD (Central Composite Design) method based on an eight-factors, three-levels fractional factorial table. Each DOE contains 157 runs to establish the multiple inputs-outputs matrix, as shown in Table 2.2.2-g.

**Table 2.2.2-g: DOE Table**

PS	*SS	*Pri_Dam	*Ver_Dam	*Lat_Dam	*Long_Dam	*Cock_bush	*Rad_Bush	*L_v	*dQ_Q	*car_ver_acc	*car_lat_acc	*truck_lat_acc	*trk_shift_for	
1	1	1	1	1	1	1	1	3	0.1655	0.365	0.066778797	0.071253823	0.7717	21959.952
2	1	1	1	2	2	1	2	3	0.1655	0.3664	0.074801223	0.069082569	0.8378	24066.5691
3	1	1	1	2	3	2	3	1	0.1642	0.4027	0.07617737	0.075749235	0.9371	24623.5862
4	1	1	1	3	1	2	1	3	0.2216	0.3695	0.076095821	0.06490316	0.825	29321.0472
5	1	1	1	3	2	1	2	2	0.1658	0.3662	0.07922526	0.073333333	0.864	24389.164
6	1	1	2	2	2	2	2	1	0.1631	0.2947	0.099653415	0.067278287	0.8393	23379.2368
7	1	1	2	3	1	1	1	1	0.1737	0.4601	0.101314985	0.073944954	0.968	25547.3529
8	1	1	2	3	1	1	3	1	0.1633	0.4657	0.103802243	0.075412844	0.998	23764.3618
9	1	1	2	3	3	3	2	2	0.401	0.3488	0.103088685	0.074485219	0.9992	60976.5141
10	1	1	3	1	1	1	3	2	0.162	0.7699	0.108002039	0.063343527	0.796	22196.9459
11	1	1	3	3	2	1	2	3	0.1655	0.5598	0.124220183	0.067319082	0.8616	24444.4863
150	3	3	2	3	1	1	1	3	0.2032	0.5243	0.178267074	0.062364934	0.9422	30678.4168
151	3	3	2	3	1	2	2	3	0.3942	0.2619	0.182589195	0.07146789	1.1504	58248.2417
152	3	3	2	3	3	3	1	2	0.4742	0.3011	0.180224261	0.076656473	1.1023	75125.031
153	3	3	3	1	3	1	1	2	0.1903	0.5999	0.178358818	0.068326236	0.9347	31217.6586
154	3	3	3	2	1	2	3	1	0.2008	0.5946	0.185922526	0.0682263	0.9477	31591.2567
155	3	3	3	2	2	1	1	3	0.2037	0.6217	0.182670744	0.067186544	0.9352	32031.1018
156	3	3	3	2	2	3	1	2	0.4782	0.2532	0.184026504	0.077217125	1.1181	75441.9791
157	3	3	3	3	2	2	2	3	0.3758	0.4373	0.190907238	0.07351682	1.0543	57778.901

Table 2.2.2-h shows the three levels of each suspension parameter in the fractional factorial table described above. For each case, the three levels are given by the minus 40 percent value, the nominal value, and the plus 40 percent value.

**Table 2.2.2-h: 3 Levels of Suspension Parameters**

			Variable	Fram Hung	% range
				Nom	
suspension	Vert	primaryN/m	PS	8.29E+05	+/-40%
	Vert	secondaryN/m	SS	8.32E+05	+/-40%
damper		axle.dam(Ns/m)	Pri_Dam	5.00E+04	+/-60%
		vert.dam(Ns/m)	Vert_Dam	2.00E+05	+/-60%
		lat.dam(Ns/m)	Lat_Dam	1.47E+05	+/-60%
		long.dam(Ns/m)	Long_dam	6.53E+05	+/-60%
bushings	Tie Rod bush	Radial(N/m)	Rad_Bush	1.50E+08	+/-50%
		Cocking(Nm/deg)	Cock_Bush	7.50E+02	+/-50%

**Track disturbances used for DOE analysis**

In addition to the track configuration (straight and curved tracks) and wheel-rail profile combination (new and worn profiles), track quality (track irregularities) also largely impacts the dynamic responses of the locomotive. The track irregularities specified in MCAT are deterministic disturbances whose amplitudes are the maximum allowable safety values for the corresponding track classes. In reality, the track irregularities are random.

To understand whether the MCAT track inputs can sufficiently represent the response characteristics of the locomotive, a comparison between the simulation results—using measured track inputs and the MCAT inputs—was conducted. The comparison results are shown in Figures 2.2.2-l and 2.2.2-m below. For this comparison, the random track irregularities measured on a Class 5 track were used. The comparison results show that for the same track class, the responses under MCAT inputs are much more severe than the responses caused by the measured random track irregularities. Therefore, it was felt that the MCAT inputs alone would be sufficient to represent the track qualities for the response surface study.



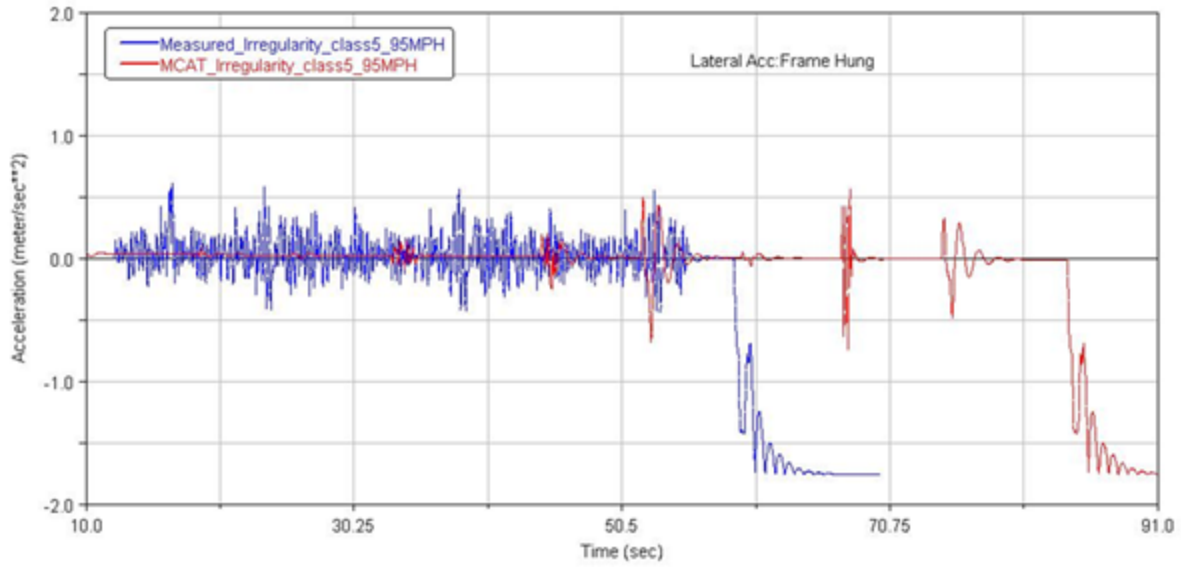

(a) Lateral carbody acceleration

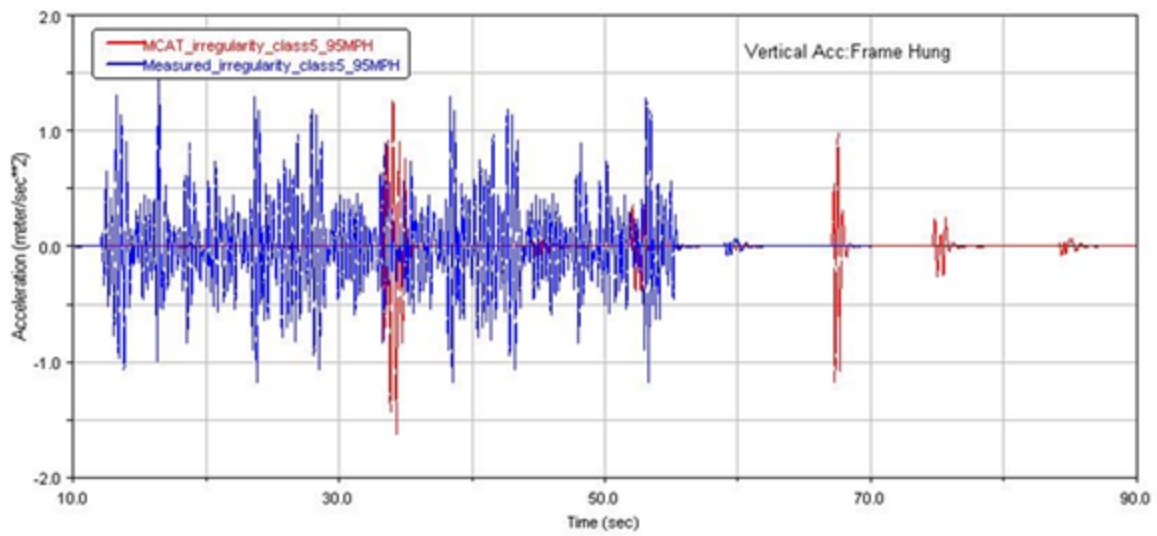

(b) Vertical carbody acceleration



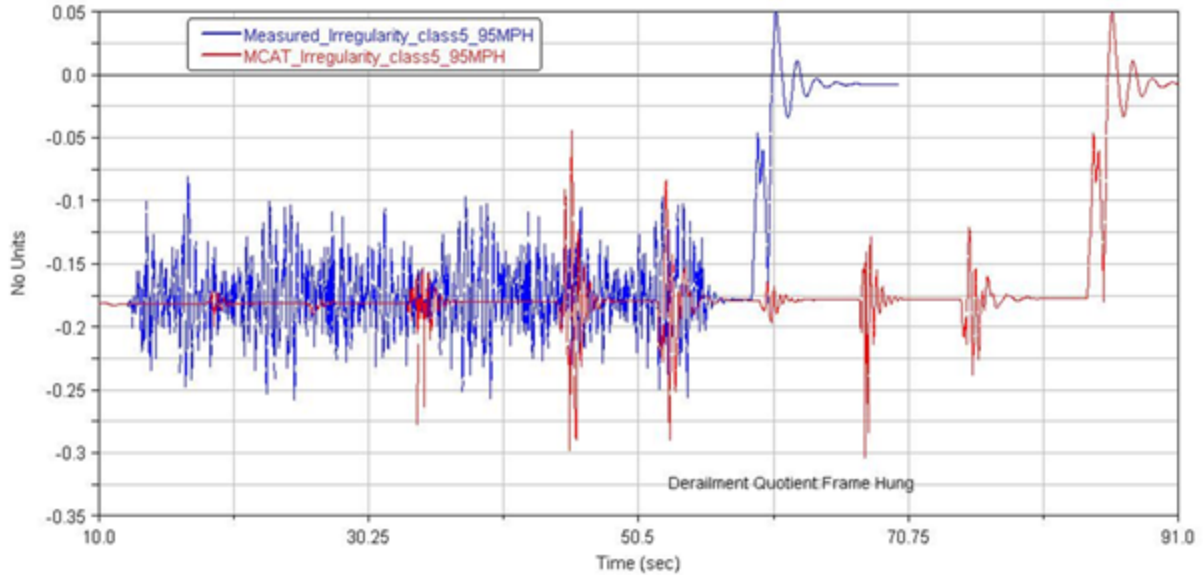

(c) Derailment coefficient of the outside wheel of the leading axle

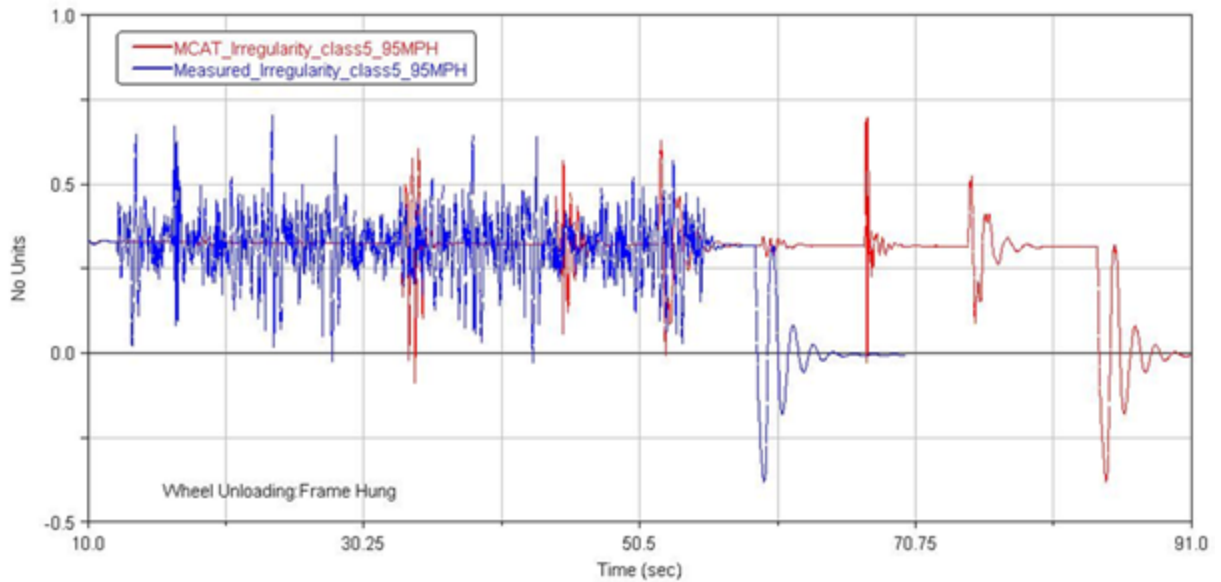

(d) Wheel unloading rate of the outside wheel of the leading axle

**Figure 2.2.2-1: Comparison of the responses on curved track between MCAT track inputs and measured random track inputs**

(1.9-degree curve, 6-inch superelevation, measured Class 5 track irregularities versus MCAT Class 5 inputs, frame-hung motor, loco speed 95 mph)

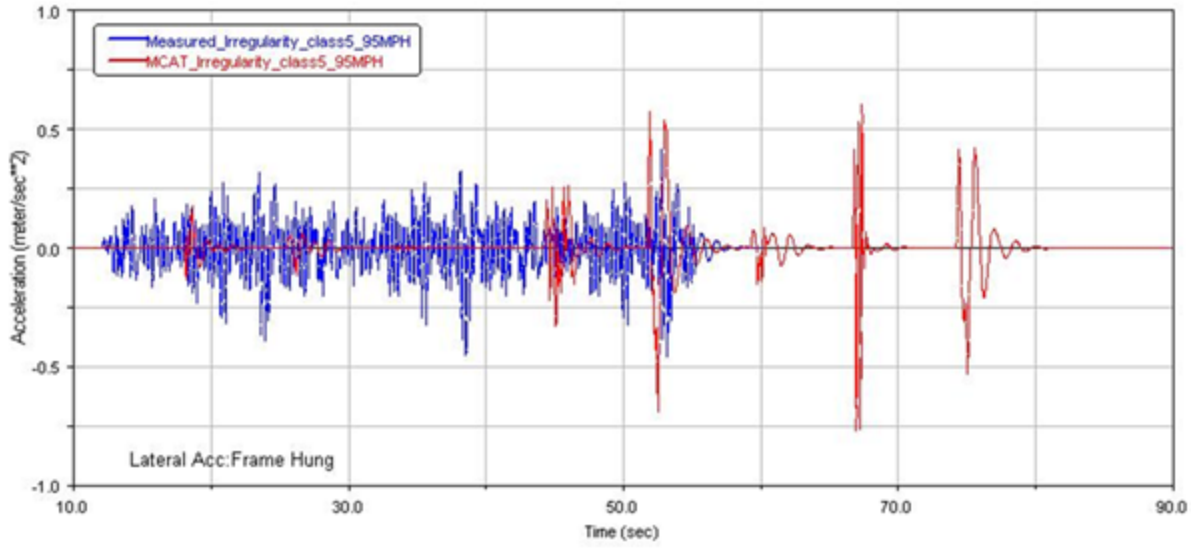

(a) Lateral cabody acceleration

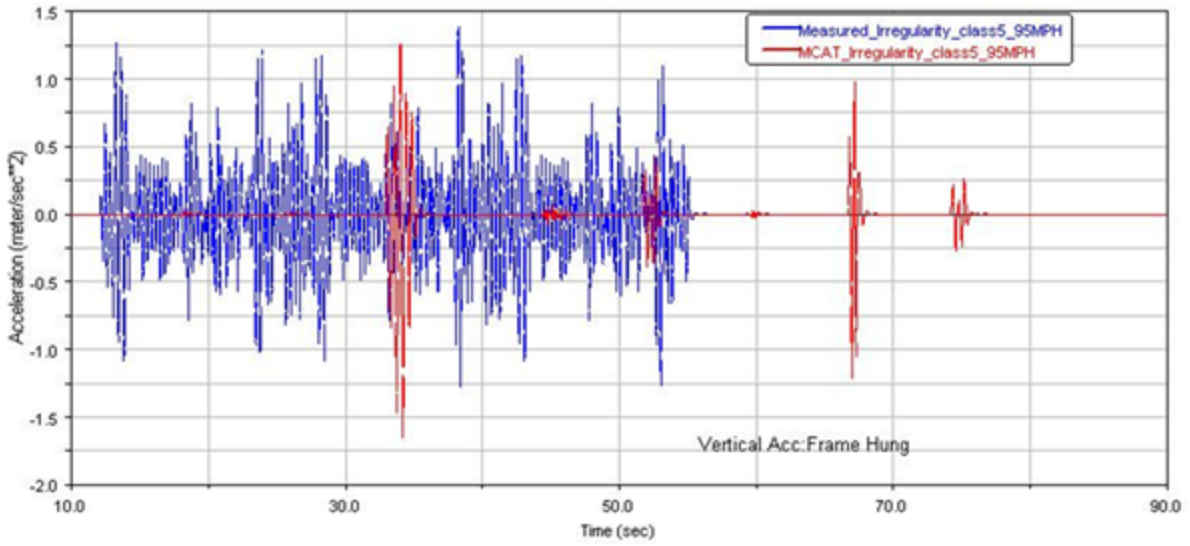

(b) Vertical cabody acceleration

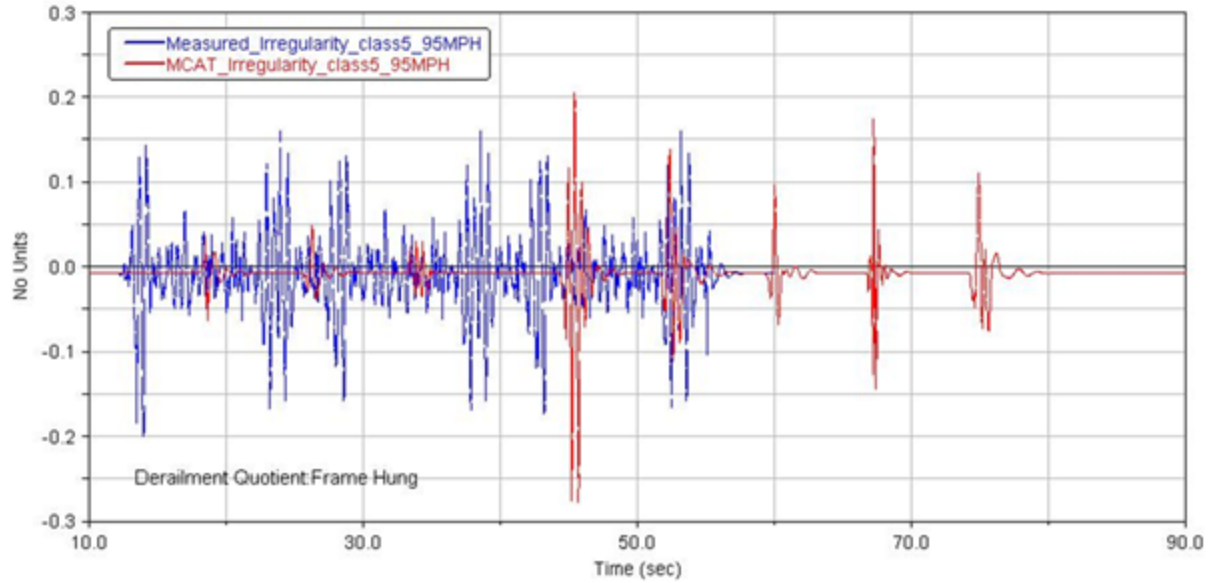

(c) Derailment coefficient of leading axle

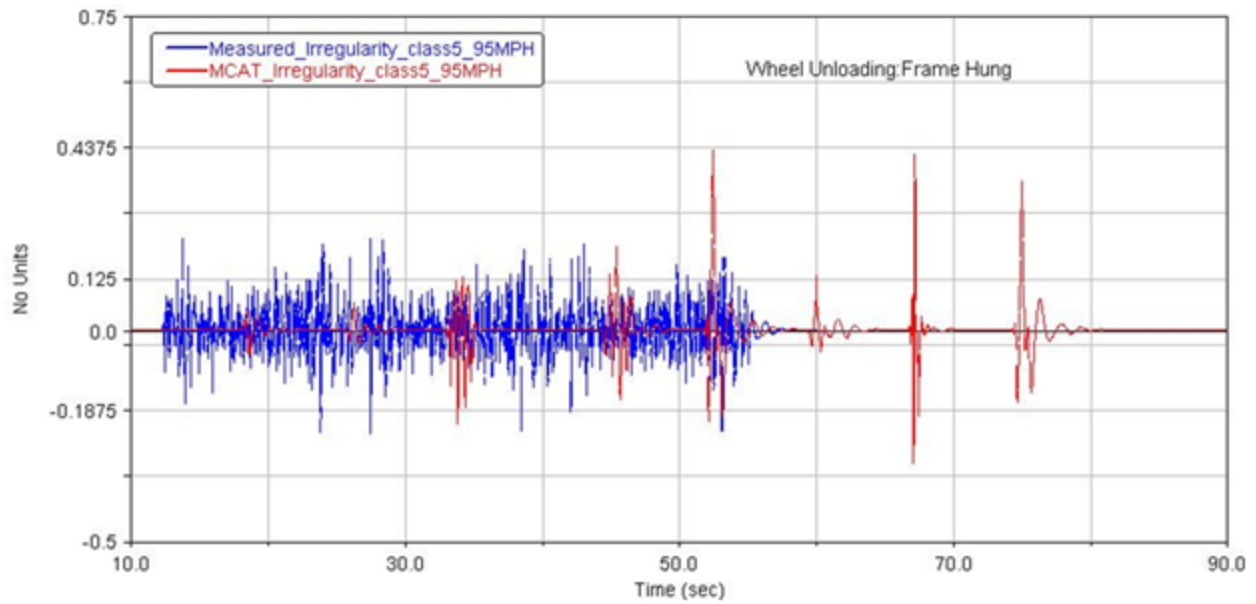

(d) Wheel load reduction rate of leading axle

**Figure 2.2.2-m: Comparison of the responses on straight track between MCAT track inputs and measured random track inputs**

(Measured Class 5 track irregularities versus MCAT Class 5 inputs, frame-hung motor, loco speed 95 mph (MCAT Class 5 inputs on curved track are used for straight track))

Table 2.2.2-i shows the combinations of track configuration, track disturbances, and wheel-rail profiles for the DOE and response surface analysis. As explained above, the MCAT track inputs were deemed sufficient, and the wheel-rail input combinations identified with an X in table 2.2.2-i below were chosen to provide sufficient range of combinations and fit within the budget and timing of this study.

As indicated in the discussion of the DOE design, each of the combinations marked with “X” below will require 157 simulations (runs) to find the response surfaces for the six specified performances. All together, this means that at least  $6 \times 157 = 942$  simulations should be conducted.

As the MCAT inputs are individual track irregularities, the responses will be transient, and a RMS evaluation is not possible. Hence, the outputs of the DOE simulation will focus on the evaluation of transient responses, meaning only peak values will be considered.

**Table 2.2.2-i: Combinations of Track and Wheel-Rail Inputs for Response Surface Analysis**

Track Configuration		Model 2 – TM Frame hung			
		New W New R	Worn W Worn R	New W Worn R	Worn W New R
Straight Track	MCAT Track Input	X	X	X	
	Measured Track Input				
Curved Track	MCAT Track Input	X	X	X	
	Measured Track Input				

### Optimization and Feasible Design Space

Based on the response surfaces and their regression functions, as determined by the DOE simulations, an optimization of the performance responses will be conducted to find the best suspension parameter combinations. As indicated before, this is an optimization which handles multiple design parameters and multiple objectives. Moreover, the optimization has to cover the different track configurations (straight and curved tracks), as well as different wheel-rail profile combinations. The suspension parameters which result in optimized performances on straight track may not necessarily be good, or even acceptable, for curved track. Similarly, the suspension parameters which can provide optimum performance for new wheel-rail combinations may not necessarily be the best suspension parameters for worn wheel-rail combinations. Therefore, a simple approach that involves looking for the common parameter space which can meet all the performance requirements under all track conditions and wheel-rail combinations will be used, as shown in Figure 2.2.2-n.

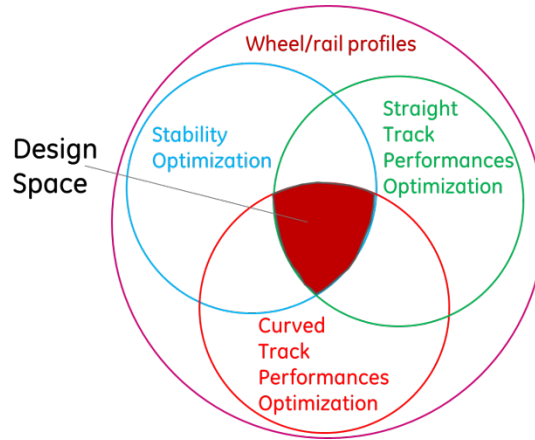

**Figure 2.2.2-n: Strategy of determining feasible design space**

### **2.2.3 Results**

#### **Presentation of results**

The following plot formats are used to describe the results:

#### Response surface fit

In general, the response surfaces are fitted first by using third-order polynomial functions of the design variables. Depending on the characteristics of the responses, the effect of going with a higher order of some of the design variables or their combinations may not be significant. In that case, the fit is then approached with a lower order, like second-order or linear functions to capture the major effects of the design parameters. The quality of the fit is controlled by the R-sq, as indicated in Figure 2.2.3-a. In general, the response surfaces are close to or higher than 97 percent.

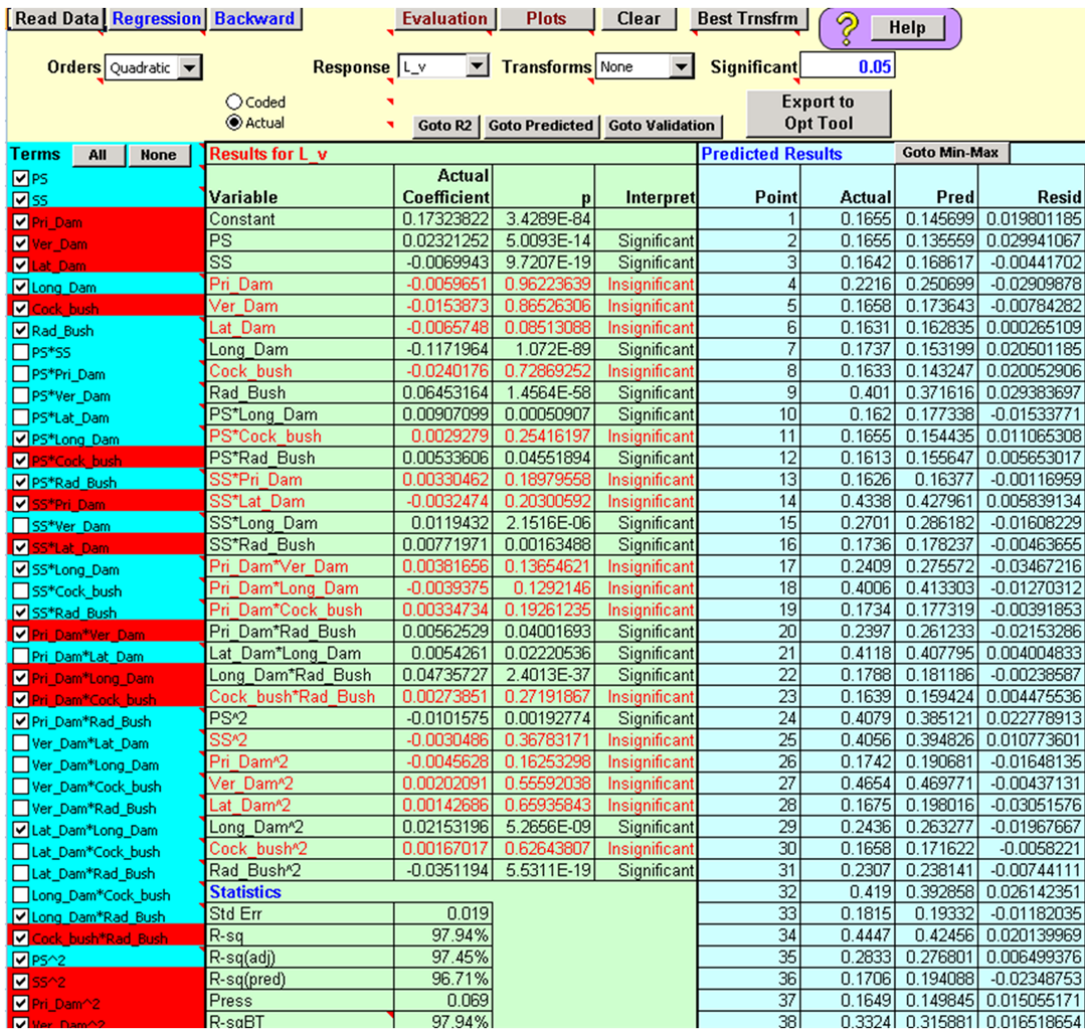
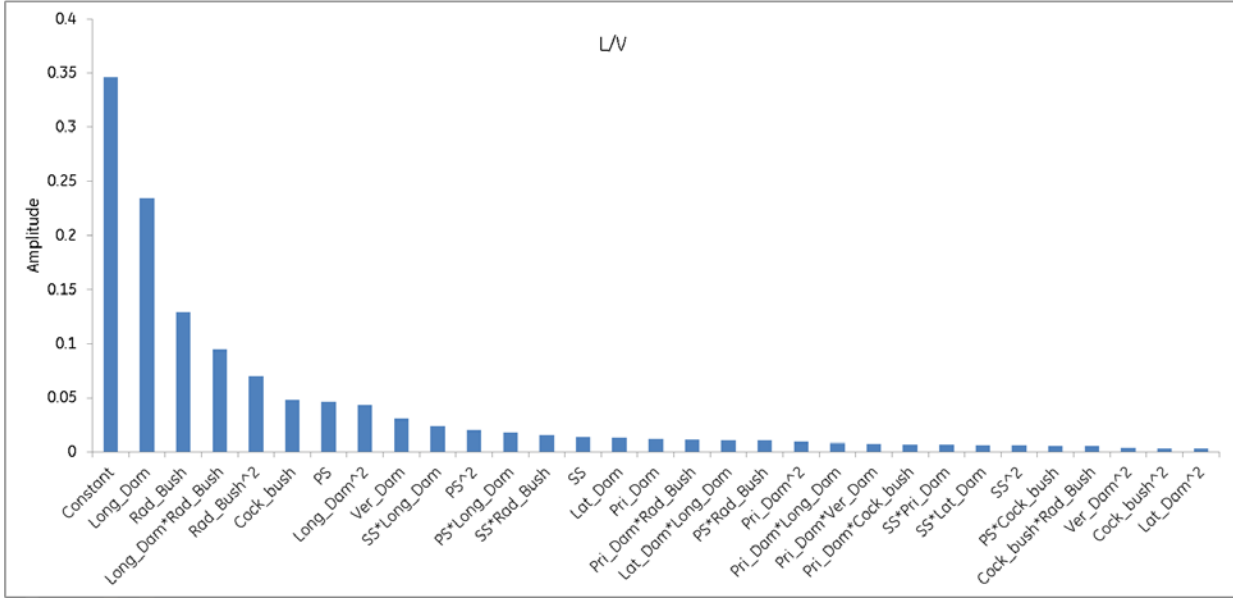

Figure 2.2.3-a: Regression functions of the response surfaces

### Pareto plot of coefficients of regression functions

A Pareto plot is used to visually demonstrate the effect of different design parameters on the selected performance. According to the design of the GE DFSS GEN III tool, the three levels of each design variable are normalized to (-1, 0, 1) and the vertical axis of the Pareto plot represents the value of  $2 \cdot \text{abs}(\text{coefficient})$  of the corresponding design parameters or their combinations on the horizontal axis, as shown in Figure 2.2.3-b. It is a simple indication of which term (parameter or parameter combinations) in the regression function(s) may have the greatest effect on (or contribution to) the specific performance for the specified variable range (in the normalized case, the range is 2 for each variable). It can help easily identify the most important parameters for the suspension design. It should be noted that the Pareto charts plot only the absolute value of the coefficients.

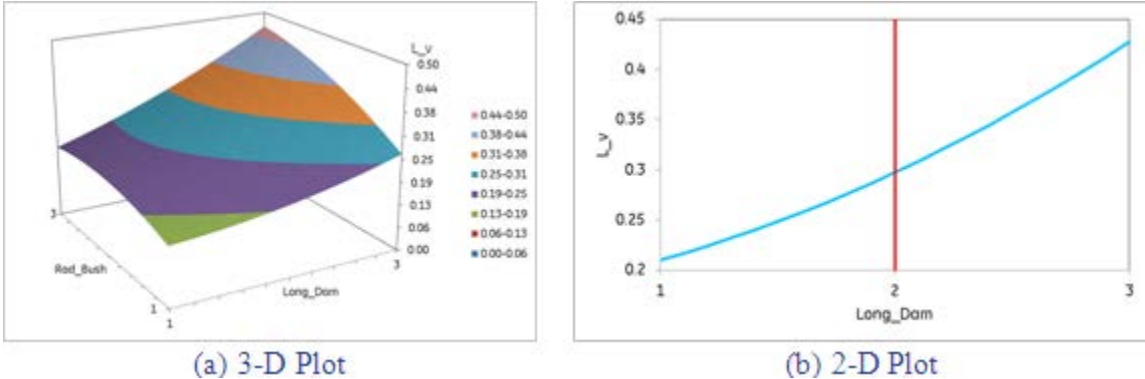



**Figure 2.2.3-b: Pareto plot**

**Sensitivity plot**

The sensitivity plot is used to demonstrate how the change of an individual design parameter will impact the performance. It is a quasi-2D or 3D plot of the response surface in which all the other parameters will be fixed to their center-point (level 2) values in the DOE table, as shown in Figure 2.2.3-c.



**Figure 2.2.3-c: Sensitivity plots**

**Results of Stability Analysis**

The proposed concept of a two-axle truck with frame-hung motor was analyzed first for its stability. A linear stability analysis—using the equivalent conicities that correspond to the three wheel-rail profile combinations—was conducted to predict the preliminary critical speeds. As the results in Figure 2.2.3-d show, the linear critical speeds of the frame-hung concept are well above the axle-hung concept, and more importantly, well beyond the required maximum operation speed of 125mph (55.9 m/s). The illustrated curves of critical speed vs. equivalent conicity were calculated based on the values of the center levels of the suspension parameters. For reference purpose, the results of the truck with axle-hung motor are also showed in the figure. Its critical speed is much lower than the frame-hung motor concept.

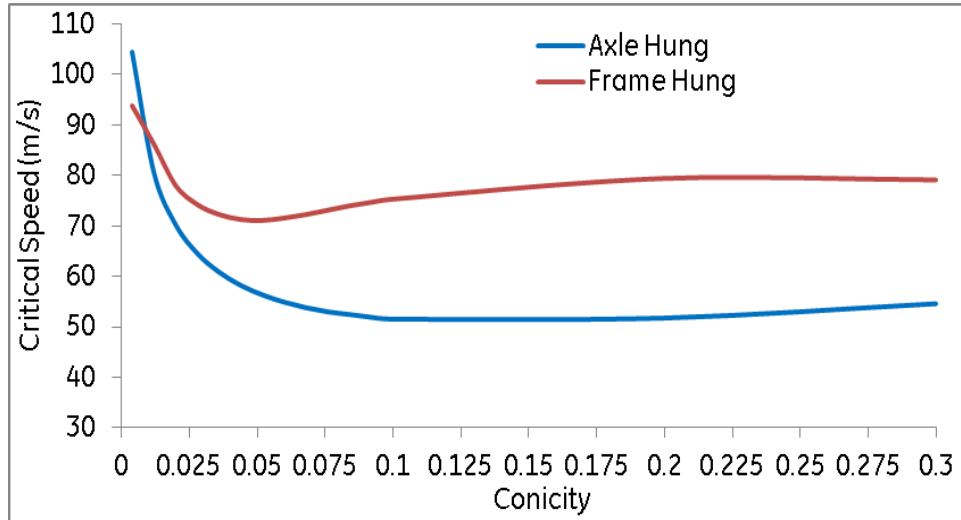

**Figure 2.2.3-d: Stability analysis of the selected concept with frame-hung motor**

As indicated in the discussion of wheel-rail contact geometry in Section 2.2.2, the contact parameters are nonlinear functions of the lateral displacement of the wheelset. In general, they are not constant. This is the case, especially, for worn wheel-rail profiles. The results of the linear stability analysis are only a prediction of the critical speed for real wheel-rail profile combination. To confirm that the critical speed of the concept meets the speed requirement, nonlinear analysis was conducted by simulating the locomotive with real wheel-rail profiles through a track section with a single lateral track disturbance (half sine wave with amplitude of 5 mm). Figures 2.2.3-e and 2.2.3-f show the results of the nonlinear analysis. The nonlinear critical speed for truck with axle-hung motor is at least 156.5 mph (75 m/s), and at least 161 mph for truck with frame-hung motor. Both are well above the prediction results of the linear stability analysis.



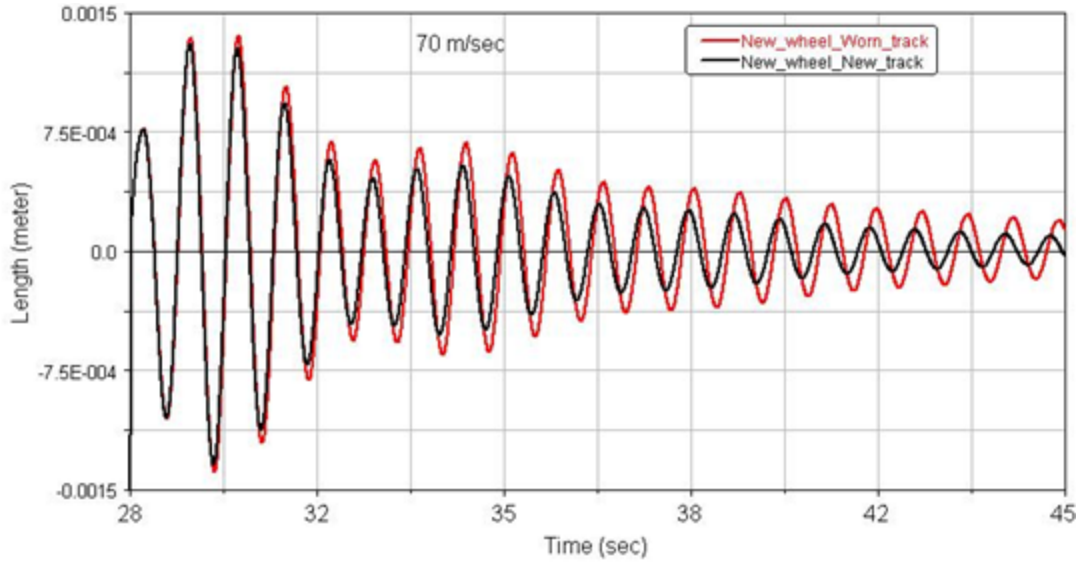

(b) Response at 156.5 MPH (70m/s)

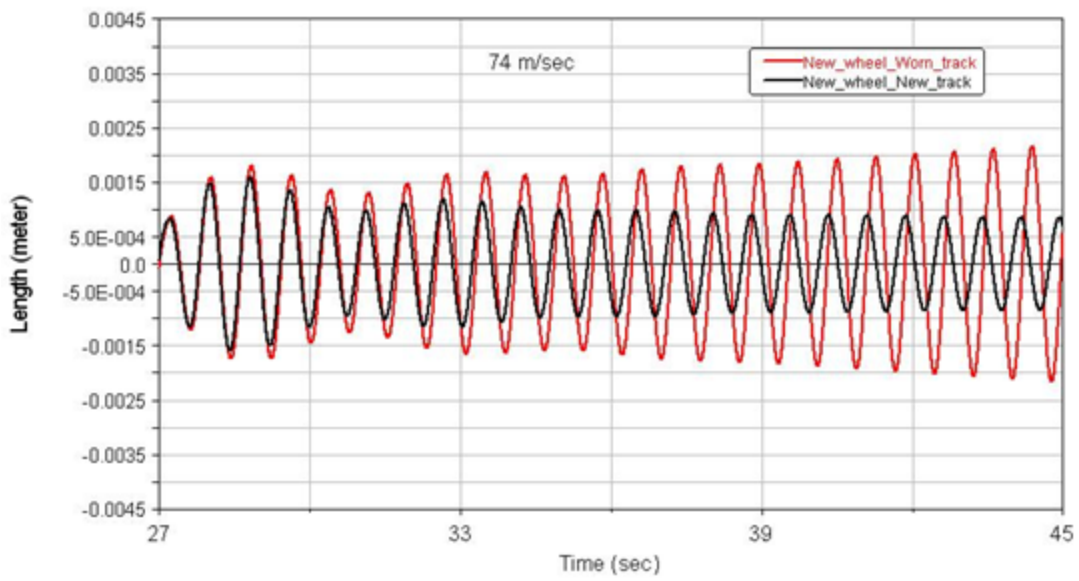

(b) Response at 165.5 MPH (74m/s)

**Figure 2.2.3-e: Lateral displacement of leading axle—truck with axle-hung motor**

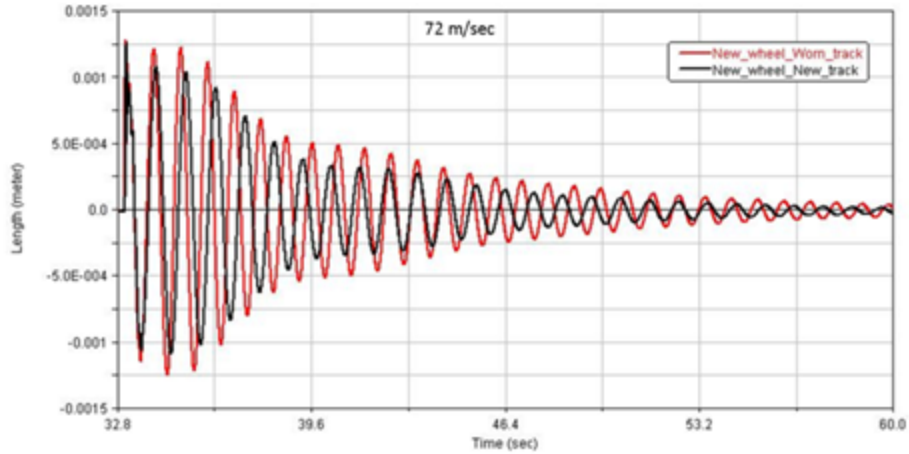

(a) Response at 161 MPH (72m/s)

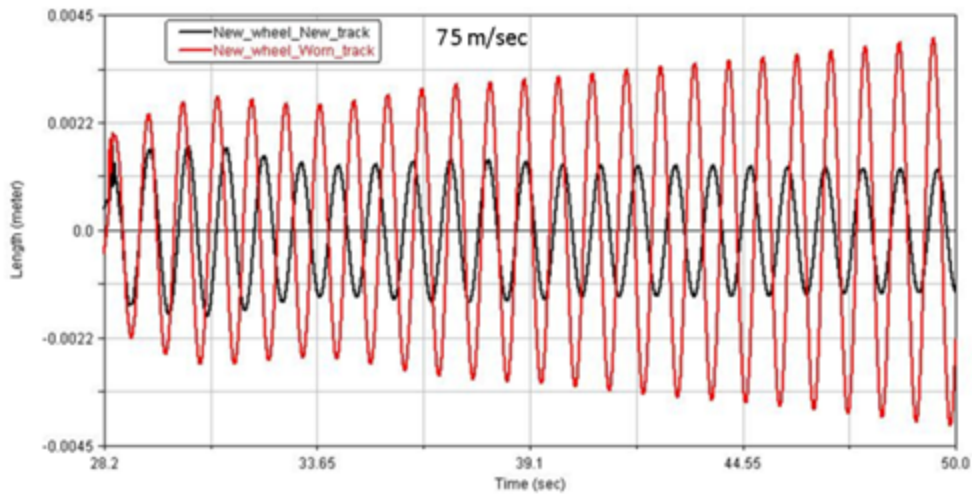

(b) Response at 167.7 MPH (75m/s)

**Figure 2.2.3-f: Lateral displacement of leading axle—truck with frame-hung motor**

Figures 2.2.3-g(a) and 2.2.3-g(b) below show the Pareto and sensitivity analysis results of the critical speeds using linear stability analysis. As indicated, the critical speed is relatively sensitive to the longitudinal and lateral stiffness (Rad\_Bush) of the axle guiding device (three-point primary traction link), yaw damping (Long\_Damp), and the secondary vertical damping (Vert\_Damp).

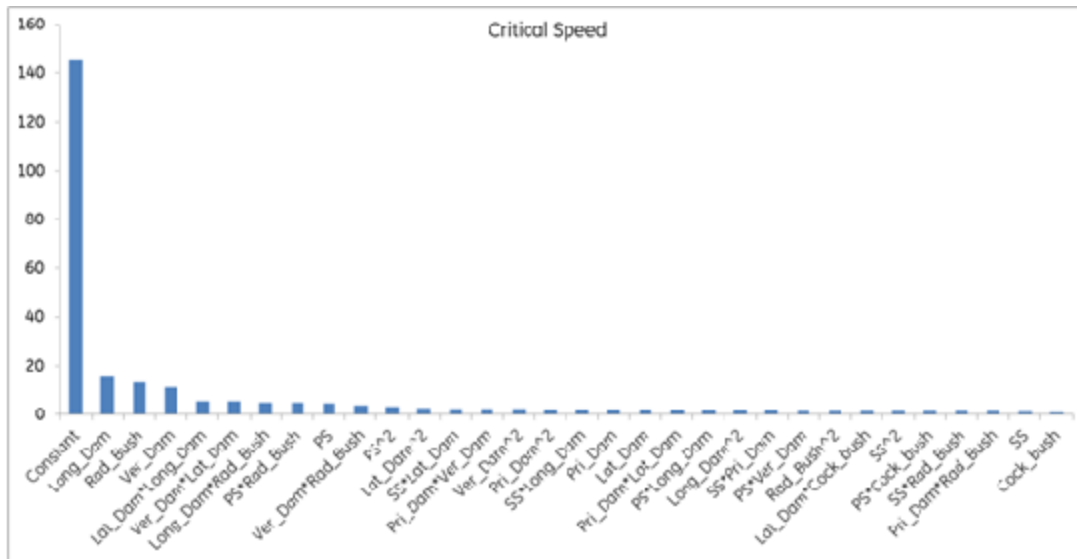

(a) Pareto results based on regression function of the response surface

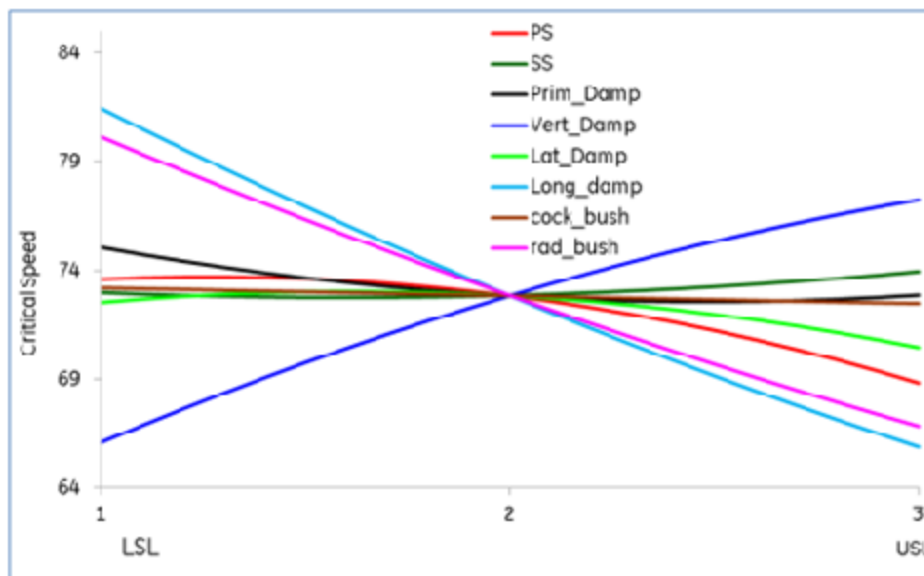

(b) Sensitivity analysis – curves are based on the center levels of the suspension parameters

**Figure 2.2.3-g: Pareto and Sensitivity analysis of linear critical speed – 2-axle truck with frame-hung motor, worn wheel, and worn rail profiles**

**Results of other performances:**

**Derailment coefficient L/V, wheel load reduction rated Q/Q, track shift force, vertical and lateral car body accelerations, lateral truck acceleration**

Based on the designed response surface DOE in Table 2-7 and the parameter levels in Table 2-9, simulations were conducted for each of the track and wheel-rail profile combinations in Table 2-9. Figure 2.2.3-h shows examples of the simulation results of some of the performances in time domain in which the corresponding MCAT inputs are also indicated for correlation and understanding. As indicated, the responses of each performance parameter to different track

inputs vary. To develop the response surface of the specific performance, only the maximum value of the response amplitudes on the specified track will be taken for the DOE point. For example, the maximum value of the lateral car body acceleration happens at the location of the “single surface” input which introduces both vertical and cross level disturbances to the locomotive. That maximum value will be taken as the response of the lateral car body acceleration for the simulated DOE point (in this case, it is the DOE point at which each of the suspension parameters has the value of level 2).

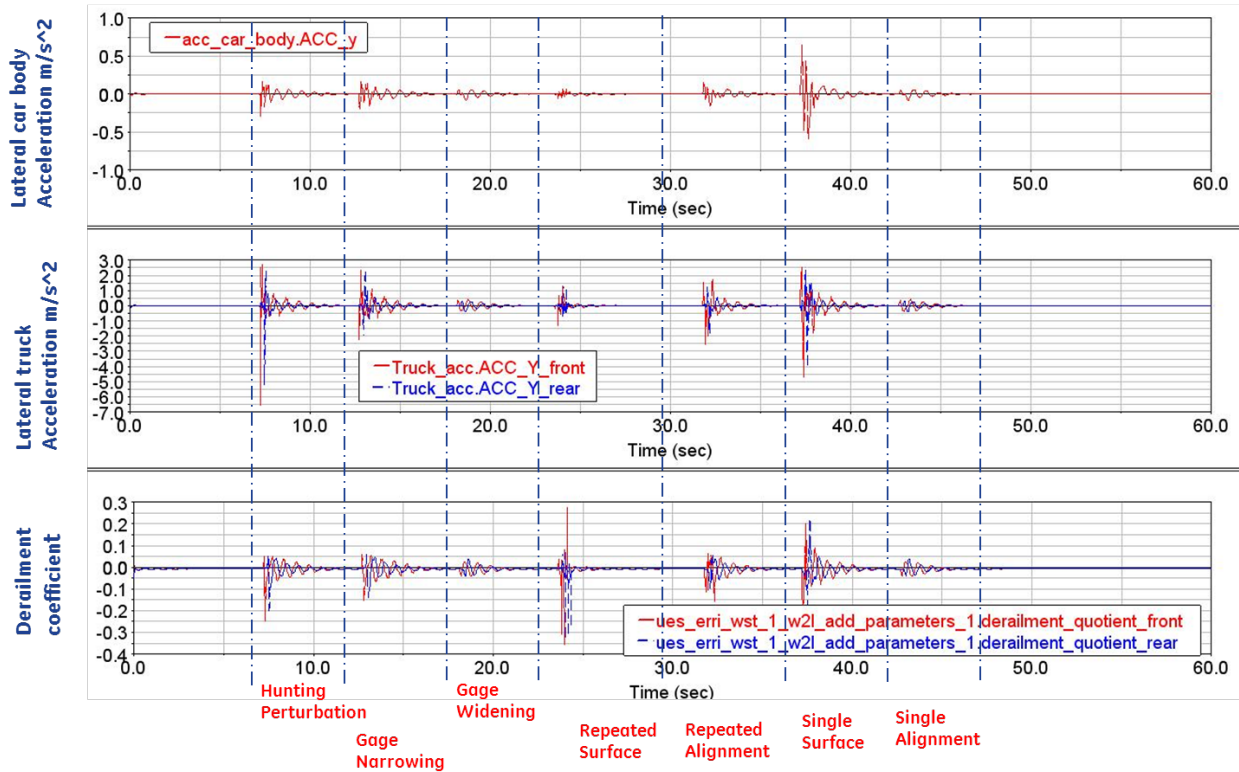

**Figure 2.2.3-h: Example of simulation results—frame-hung motor, class 7 MCAT straight track inputs, new wheel-rail profiles, 125 mph, middle points (level 2) of the suspension parameters**

The Pareto and sensitivity analysis results based on the response surfaces of the six performance parameters for various wheel and rail profiles, as well as the track conditions, are shown in detail in Appendix D. In general the response surfaces are nonlinear, and the effects of different design parameters on the performances vary. The performances may be sensitive only to some of the design parameters. Figure 2.2.3-i illustrates some examples of the sensitivity analysis results for the new wheel and worn rail profile combination. Figures 2.2.3-i (a) and (b) are lateral car body and lateral truck accelerations on straight track, and Figures 2.2.3-i (c) and (d) are wheel L/V and track shift forces on curved track. Note that increasing the radial stiffness of the bushings in the axle guiding devices (equivalent to longitudinal and lateral stiffness of the guiding device) can reduce the lateral car body and truck accelerations, and therefore improve the stability on straight track. But such an increase would negatively impact the derailment coefficient on curved track. One very interesting observation in Figures 2.2.3-i (a) and (b) is that the lateral car body and truck accelerations are relatively sensitive to primary and secondary vertical stiffness. This

seems strange at first glance, but by looking at the simulation model, it is understood that this is due to the setup of the relationship between the lateral stiffness and the vertical stiffness in the primary and secondary suspensions:  $\text{lateral\_stiffness}/\text{vertical\_stiffness} = c$ . Increasing the primary and secondary vertical stiffness will also increase their lateral stiffness and therefore impact the lateral vibrations of the locomotive. This special setup in the model should be carefully considered while interpreting the results in order to avoid any confusion.

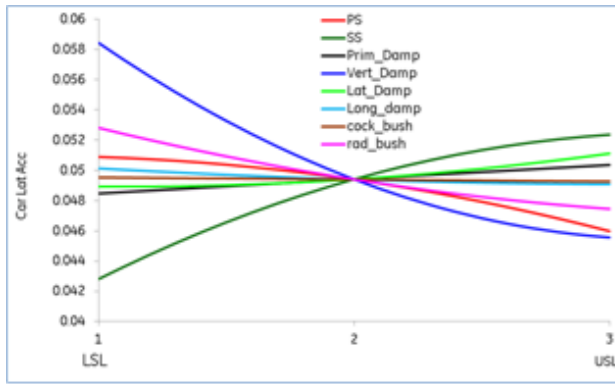

(a) Lateral car body acceleration in  $\text{m/s}^2$  (straight track)

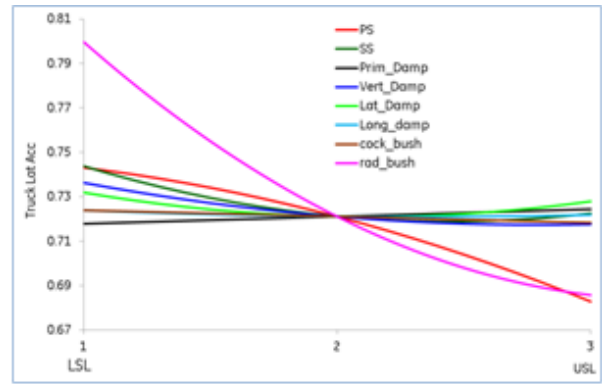

(b) Lateral truck acceleration in  $\text{m/s}^2$  (straight track)

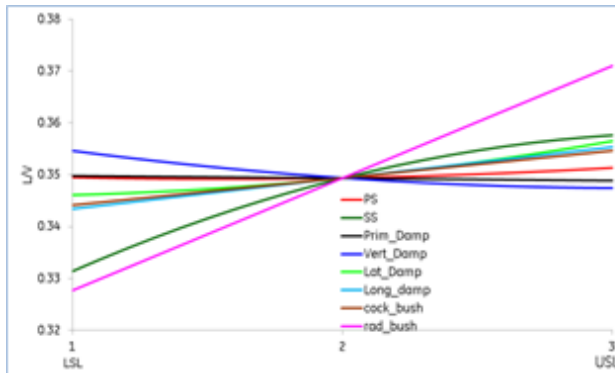

(c) Wheel L/V (1.1 degree curve, 6'' superlevation)

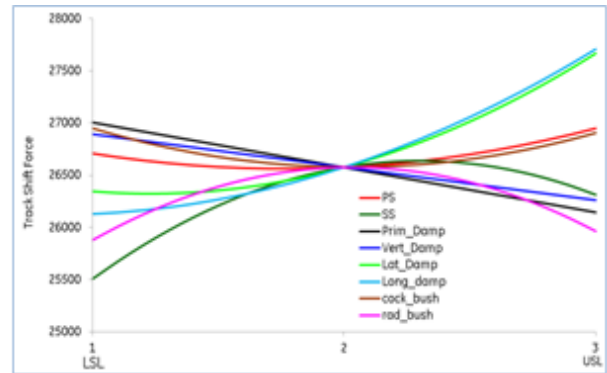

(d) Track shift force in (N) (1.1 degree curve, 6'' superlevation)

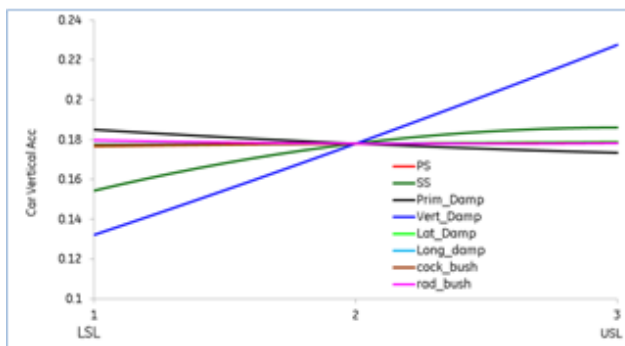

(e) Vertical car body acceleration in  $\text{m/s}^2$  (straight track)

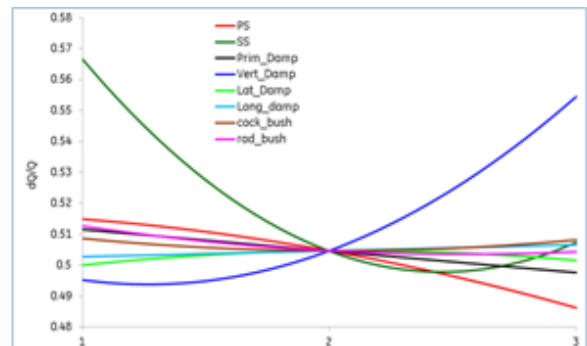

(f) Wheel load reduction rate  $dQ/Q$  (1.1 degree curve, 6'' superlevation)

**Figure 2.2.3-i: Sensitivity analysis results for truck with frame-hung motor, new wheel, and worn rail profiles, class 7 track, 125 mph**

It seems that the secondary vertical damping (Vert\_Damp) has great influence on the performances, especially on the lateral car body acceleration, due to its influence on the roll motion of the car body. Increasing the secondary vertical damping can reduce both the lateral car body and truck accelerations. It can also help reduce the L/V ratio and the track shift force. But it will increase the vertical car body acceleration and wheel load reduction rate, as shown in Figure 2.2.3-i (e) and (f).

As indicated before, different wheel-rail profile combinations significantly impact dynamic performances. Figures 2.2.3-j (a) to (h) below show comparisons of some of the sensitivity analysis results between profile combinations of new wheel and worn rail, and worn wheel and worn rail. Due to different wheel-rail profile combinations (and the different contact geometry parameters, see Figures 2.2.2-g to 2.2.2-j), the sensitivity of the performances to the design parameters is also different. The effect of the secondary yaw damping (Long\_Damp) becomes more significant for the worn wheel and worn rail combination, as indicated below in Figures 2.2.3-j(b), (d), (f), and (h).

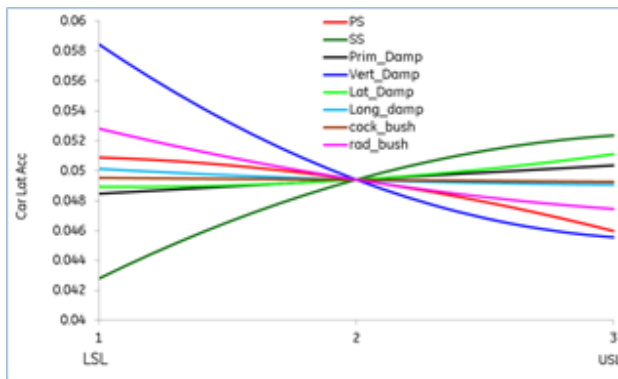

(a) Lateral car body acceleration in  $m/s^2$  (new wheel and worn rail, straight track)

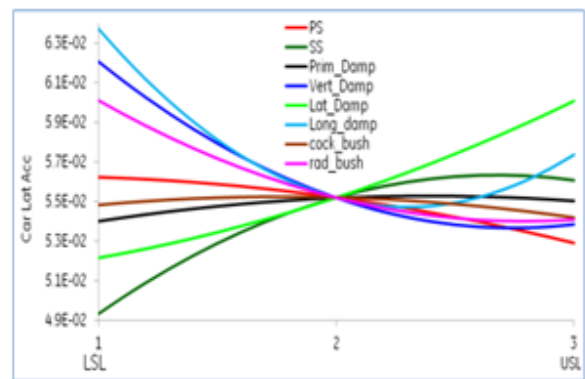

(b) Lateral car body acceleration in  $m/s^2$  (worn wheel and worn rail, straight track)

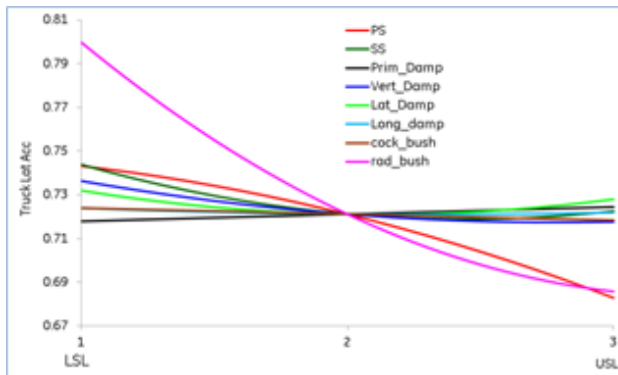

(c) Lateral truck acceleration in  $m/s^2$  (new wheel and worn rail, straight track)

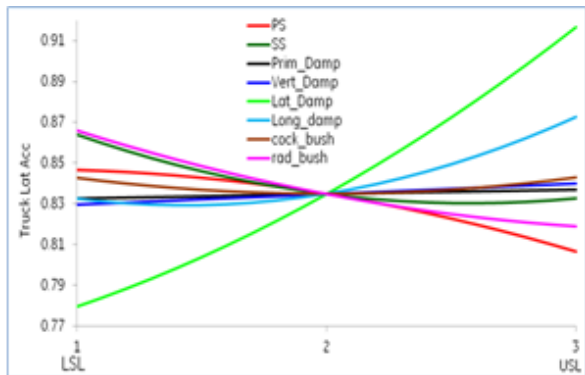

(d) Lateral truck acceleration in  $m/s^2$  (worn wheel and worn rail, straight track)



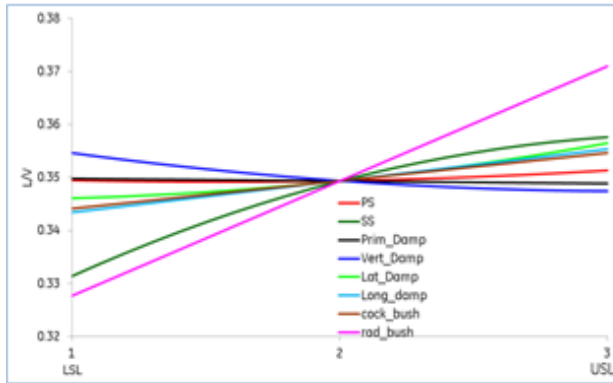

(e) Wheel L/V (new wheel and worn rail, 1.1 degree curve, 6'' superlevation)

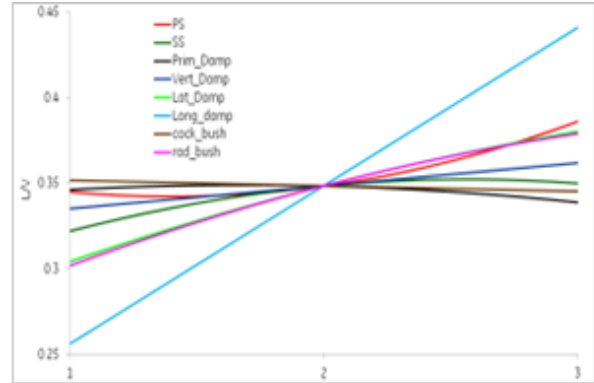

(f) Wheel L/V (worn wheel and worn rail, 1.1 degree curve, 6'' superlevation)

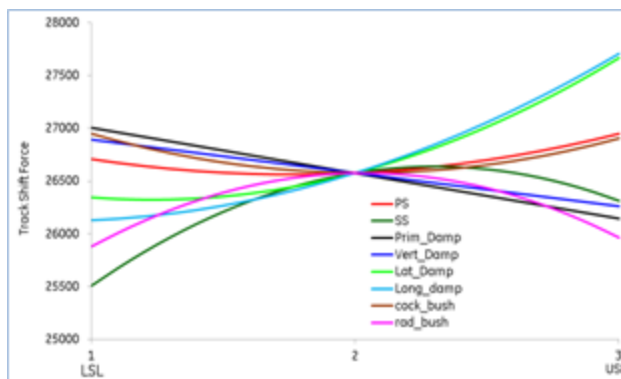

(g) Track shift force in N (new wheel and worn rail, 1.1 degree curve, 6'' superlevation)

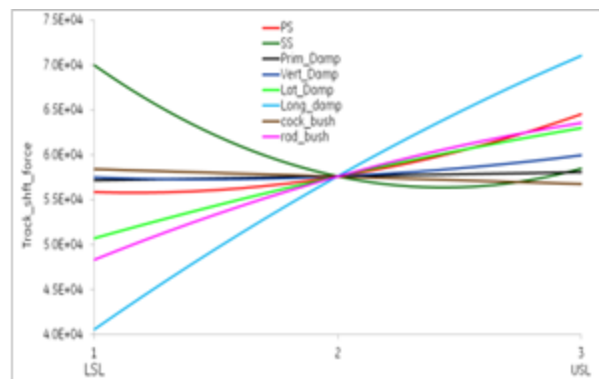

(h) Track shift force in N (worn wheel and worn rail, 1.1 degree curve, 6'' superlevation )

**Figure 2.2.3-j: Comparison of sensitivity results between different wheel-rail profile combinations (frame-hung motor, class 7 track, 125MPH)**

The secondary lateral damping also has great influence on both the lateral accelerations on straight track and the curving performance on curved track. Some of the parameters even change or reverse the trends of the influence on the performances. Examples of this reversed trend include the secondary lateral damping in the above Figures 2.2.3-j (c) and (d), the secondary vertical damping in (e) and (f), and the secondary vertical stiffness in (g) and (h).

Some of the conclusions observed for the new wheel and worn rail profile combination may no longer be applicable to the worn wheel and worn rail profile combination because the performance parameters are so dependent on the wheel-rail profiles, which change constantly during the normal operation. The selection of the design parameters is much more challenging. To meet all the dynamic performance and running safety requirements, a systematic tradeoff and optimization between the performances and design parameters for the various wheel and rail profile combinations will be necessary.

## Feasible Design Space

To develop the feasible design space of the suspension parameters, an optimization process is used. It considers the six selected dynamic performances as optimization objectives and the suspension parameters as design variables. The allowable lower and upper performance limits, as specified in MCAT, and the engineering feasible parameter variation ranges of +/-60 percent of the nominal values in the DOE analysis (see Table 2.2.2-h) are used as constraint/boundary conditions. The design space of the suspension parameters will be determined by finding all the possible parameter combinations when minimizing and maximizing the performances (objectives) within (or up to) the allowable performance boundaries.

As indicated in the previous sections, the performance responses largely depend on the track configurations (straight or curve) and wheel-rail profile combinations (new or worn). Therefore, the above stated procedure is performed for each of the track and profile combinations. The design space which will meet all track and profile combinations is then determined by the method, as illustrated graphically in Figure 2.2.2-n.

In general, the allowable variation range of one design parameter within the feasible design space will depend on the ranges of the other parameters. They interact with each other through nonlinear functions, as illustrated in Figure 2.2.3-k. For simplicity and engineering applicability, only a fixed range of each parameter will be reported in this study.

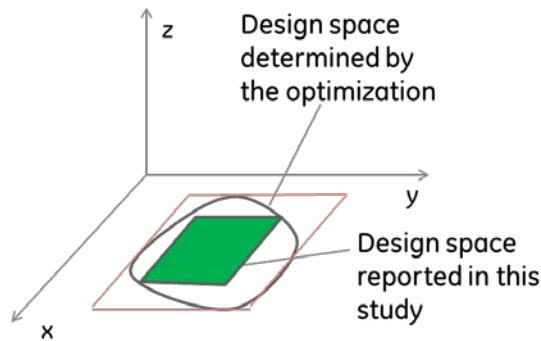

**Figure 2.2.3-k: Example of 2 dimensional design space**



Figures 2.2.3-l through 2.2.3-o provide examples of the minimization process of several performance parameters and the corresponding variations of some of the suspension parameters. The design space determined to meet both critical speed (stability) and safety performance requirements on straight and curved track is shown in Table 2.2.3-a below.

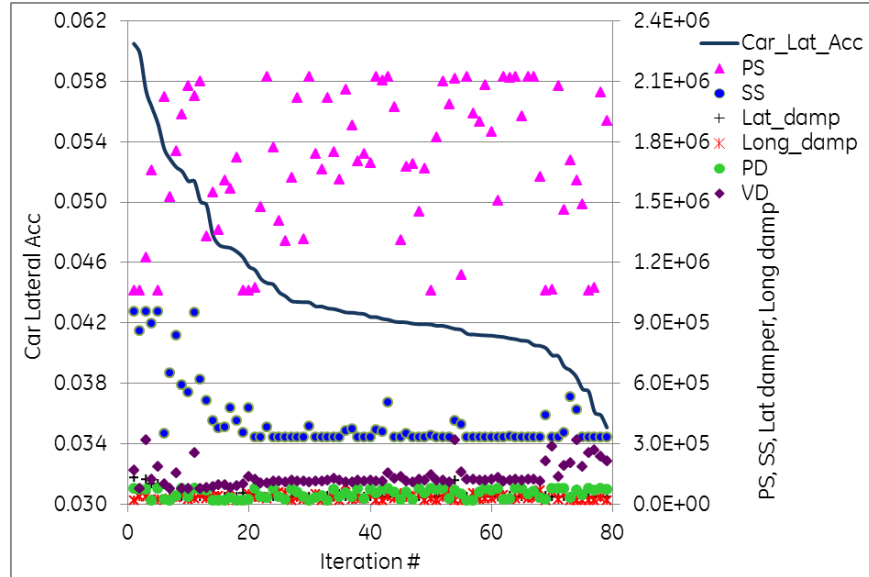

**Figure 2.2.3-l: Minimization process of lateral car body acceleration in m/s<sup>2</sup> (frame-hung motor, straight track, new wheel, worn rail, MCAT class 7 track, speed 125 mph)**

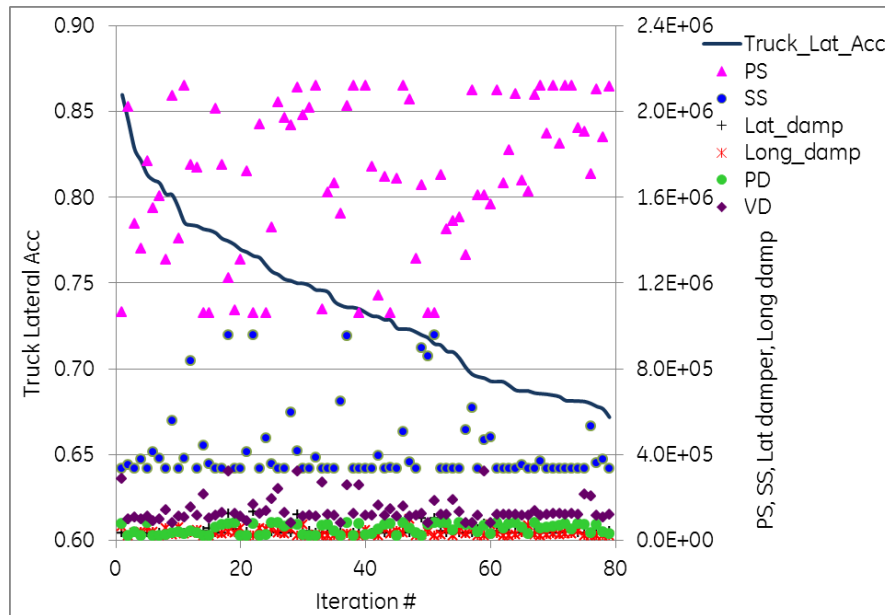

**Figure 2.2.3-m: Minimization process of lateral truck acceleration in m/s<sup>2</sup> (frame-hung motor, straight track, new wheel, worn rail, MCAT class 7 track, speed 125 mph)**

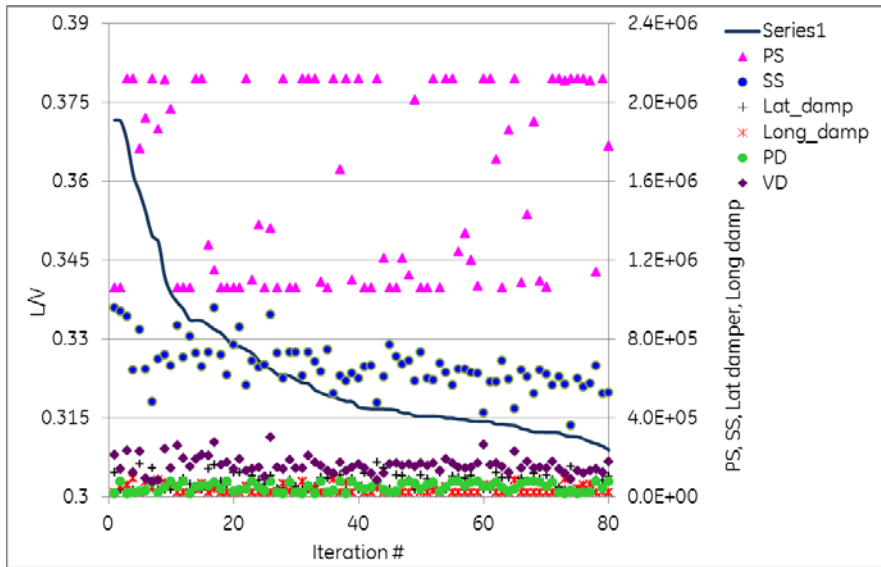

**Figure 2.2.3-n: Minimization process of L/V of leading axle (frame-hung motor, 1.1 degree curve, 6-inch superelevation, new wheel, worn rail, MCAT class 7 track, speed 125 mph)**

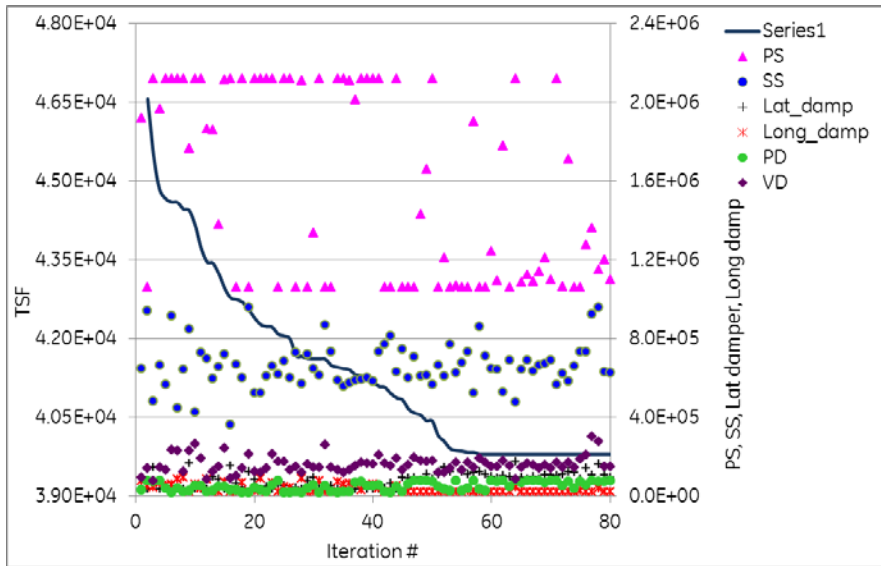

**Figure 2.2.3-o: Minimization process of track shift force of leading axle in N (frame-hung motor, 1.1 degree curve, 6-inch superelevation, new wheel, worn rail, MCAT class 7 track, speed 125 mph)**

**Table 2.2.3-a: Feasible stable and safe design space of truck with frame-hung motor**

			Nominal	% variation	Design Space	
					LSL	USL
Damper	Vertical Damper	Ns/m	2.00E+05	+/-60%	1.59E+05	3.09E+05
	Lateral Damper	Ns/m	1.47E+05	+/-60%	5.92E+04	1.36E+05
	Axle Damper	Ns/m	5.00E+04	+/-60%	4.70E+04	6.71E+04
	Longitudinal Damper	Ns/m	6.53E+05	+/-60%	2.61E+05	9.70E+05
Suspension	Primary vertical	N/m	1.30E+06	+/-60%	1.11E+06	2.08E+06
	Secondary vertical	N/m	7.32E+05	+/-60%	5.39E+05	9.16E+05
Bushings	Tie rod radial	N/m	1.20E+08	+/-50%	9.58E+07	1.65E+08
	Tie rod cocking	Nm/deg	6.00E+02	+/-50%	6.98E+02	8.80E+02

### 2.2.4 Summary

The dynamic running performance of the locomotive depends not only on the suspension parameters, but also on the track conditions and wheel and rail profile combinations. To meet the running safety requirements, the suspension design of the truck system should consider all the possible wheel and rail profile variation ranges for the specified operation conditions on both straight and curved tracks. Due to the conflicting requirements of suspension parameters between stability on straight track and derailment safety on curved track, a thorough tradeoff of the design parameters must be conducted. The tradeoff can be achieved through optimization of the critical safety related performance responses by setting realistic constraint and boundary conditions for both the design parameters and performance requirements.

### 2.2.5 Conclusions and Recommendations

The design space method developed in this study by using multi-objective optimization can provide both optimized concept of the suspension parameters and the feasible concepts which meet all the running safety requirements for both straight and curved track conditions, as well as specified wheel-rail profile ranges. This offers flexibility for engineering design. Different design concepts for the suspension system can be selected within the design space to achieve specific requirements.

For the curving performance analysis in this study, a large curve radius (1.1 degree) based on the MCAT specification was used in order to meet the 125 mph speed requirement. In practice, there may be sharper curves with smaller radii, either on a high-speed line where the train will slow down, or in cases where the high-speed locomotives may run on freight lines with smaller curves. It is recommended that future analyses include smaller curves to evaluate the derailment safety and track shift forces for a more complete range of operating conditions.

In this study, the primary lateral stiffness and secondary lateral stiffness are coupled with their corresponding vertical stiffness based on the physical products. This coupling assumption may limit the capability of the optimization, and the interpretation of the sensitivity results of such analysis is difficult and sometimes confusing. It is recommended that in future analyses the lateral stiffness be decoupled from its vertical stiffness.

As demonstrated in this study, truck stability and safety performance are significantly influenced by the worn wheel-rail profile combinations. Depending on how severely worn the profile is and which worn profile combination is used, the response behavior of the locomotive could be very different. There are a huge number of possible profile combinations and no standardized combinations within the industry. It is difficult, then, to determine which profiles should be used—and impossible to compare designs based on different profile combinations. It is recommended that consideration be given to developing an industry “standardized” worn wheel and rail profile databank based on typical measured profiles.

It is also recommended that consideration be given to establishing a maximum allowable equivalent conicity for specified speed ranges. This would ensure that the wheel and rail profiles are maintained within a range that assures safe operation.

Additional recommendations are as follows:

- (1) Develop and define standardized track irregularity inputs for corresponding track classes based on real measured track data.
- (2) Develop standardized dynamic load (g-load) inputs for strength design of truck frame and attached components, including maximum dynamic loads and fatigue loads.

## 2.3 Task 3—Dynamic Load Summary Report

### 2.3.1 Definition

The intent for Task 3 was to evaluate the impact of locomotive weight, motor suspension method, and other suspension parameters on P2 force and track lateral shift force. This task was divided into two sections: the first for the P2 force evaluation and the second for track lateral force. During the Task 3 analysis it became apparent that certain limitations of the Task 2 analysis prevented adequate exploration of P2 force and track lateral force. For the reasons explained at the end of this Task 3 report, the lateral track shift force analysis was removed from the study results.

### P2 Force

P2 force is a vertical force between the wheel and rail. The limit for the next generation diesel passenger locomotive is set by the PRIIA 305-005 specification at 82,000 lbf. This limit will be much more challenging to meet than past limits, especially since it must also be met at 125 mph.

The limit applies to defined track parameters also specified by PRIIA 305-005. In order to make a meaningful P2 force comparison between past applications and projected PRIIA applications, the P2 force of existing or past applications must be recalculated using the PRIIA track parameters.

The P2 force equation is defined in British Railways Board Group Standard GM/TT0088 Issue 1, Rev. A.

$$P_2 = P_0 + 2\alpha v \sqrt{\frac{m_u}{m_u + m_t} \left( 1 - \frac{\pi c_T}{4\sqrt{k_T(m_u + m_T)}} \right) \sqrt{k_T m_u}}$$

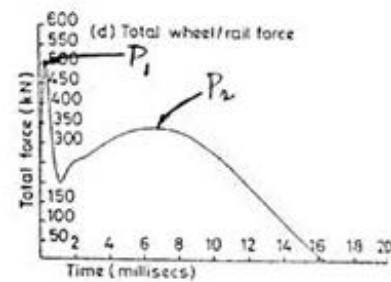
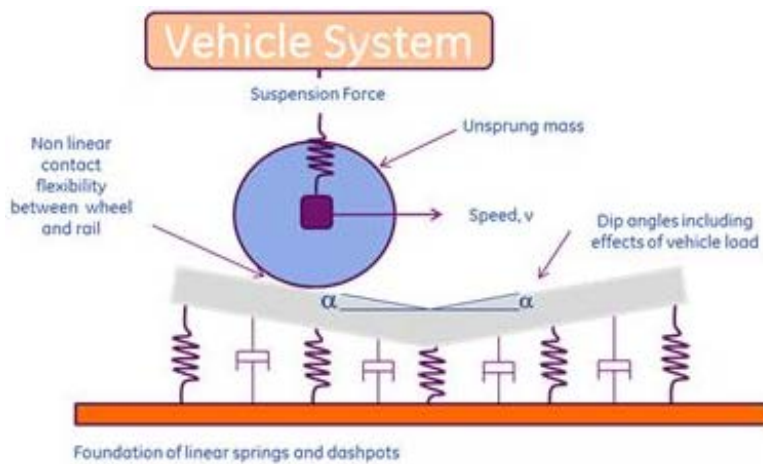

Where

- $P_0$  Static wheel load in pounds
- $\alpha$  Dip angle in radians
- $v$  Vehicle speed in inches/second
- $m_u$  Unsprung mass per wheel in lbf/in/sec<sup>2</sup>

$m_t$  Track mass per wheel in lbf/in/sec<sup>2</sup>  
 $k_t$  Track stiffness per wheel in lbf/in

The PRIIA 305-005 specification provides track parameter values as follows:

$\alpha$  = 0.0085 Total dip angle in radians based on ½ degree on both sides of the dip  
 $m_t$  = 1.1335 Track mass per wheel in lbf/in/sec<sup>2</sup> for concrete tie track  
 $c_t$  = 671 Track damping per wheel in lbf/in/sec for nominal track conditions  
 $k_t$  = 392,900 Track stiffness per wheel in lbf/in for nominally stiff concrete tie track (corresponding to track modulus of 5,100 lb/in/in, assuming a track deflection of 0.084 in under a 33,000-pound wheel load)

### **2.3.2 Approach**

Since P2 force limit is tied to specific track parameters defined in the PRIIA specification, the vehicle builders can only influence two parameters: the overall vehicle weight and the unsprung weight of each wheel set. Coinciding with the more stringent P2 force limit for the next generation passenger locomotives will be the additional requirements of meeting the Tier 4 emissions standards and stricter crash worthiness standards, each of which will add significant additional weight to the locomotive. The locomotive manufacturers will have to reduce the unsprung weight of each wheel set. Since approximately one-third of that weight comes from partial support of the traction motors, removing the traction motor from the axle is the most practical way to achieve a significant reduction in unsprung weight.

This section reviews the PRIIA P2 force specification and presents the choices available to the OEM locomotive builders.

### **PRIIA Loco Assumptions**

#### *Locomotive weight*

PRIIA locomotives are assumed to need Tier IV compliant engines which are expected to require “after treatment solutions” and will increase the overall weight of the vehicle. Additionally, new crashworthiness requirements necessitate additional weight in the car body structure.

Existing passenger, 4-axle, locomotives used in North America range from 260,000 lb to 295,000 lb, as indicated by Technology Vehicle Report issued in August 2011 by the Next Generation Equipment Committee. Considering the above weight challenges, it is reasonable to evaluate a range of locomotive weights between 260,000 lb and 300,000 lb.

#### *Unsprung Weight*

Unsprung weight is the portion of the wheel set weight in direct contact with the rail. Portions which are supported by the primary suspension are sprung weight. Unsprung weight is typically calculated from the following components for each wheelset:

#### Basic

- 2 Locomotive wheels
- 1 Locomotive axle
- 2 journal bearings
- 2 journal bearing housings
- 4 Primary springs – ½ weight (if used)

## Optional

### *For Axle-Hung motor designs*

- 1 Gear
- 2 motor suspension bearings
- 1 motor suspension bearing housing (u-tube)
- 1 Traction Motor (unsprung portion)
- Disc Brake rotors (if used)

### *For Frame-Hung motor designs*

- 1 Gear (if mounted on the axle)
- 1 Gearbox (unsprung portion – if mounted on the axle) includes bearings
- 1 Quill Drive (unsprung portion – if used)

Optional components need to be considered depending on the concept used: axle-hung versus frame-hung traction motors, drivetrain type and brake type. Considering the components described above it is likely that the unsprung weight will range from 5500 lb to 8500 lb.

## **2.3.3 Results**

### **Resulting Unsprung Weight Requirements**

Using the P2 force formula we can quickly calculate the expected P2 force for different weight locomotives and different unsprung weights for proposed PRIIA locomotives. Additionally, a comparison can be made between P2 forces on proposed locomotives and existing locos. The value of such a comparison can be appreciated when considering that past P2 force calculations have used different track parameters. Since, typically, P2 force limits are based on some vehicle which is considered acceptable, using different track parameters will result in a different P2 force on that vehicle and therefore a different P2 force limit.

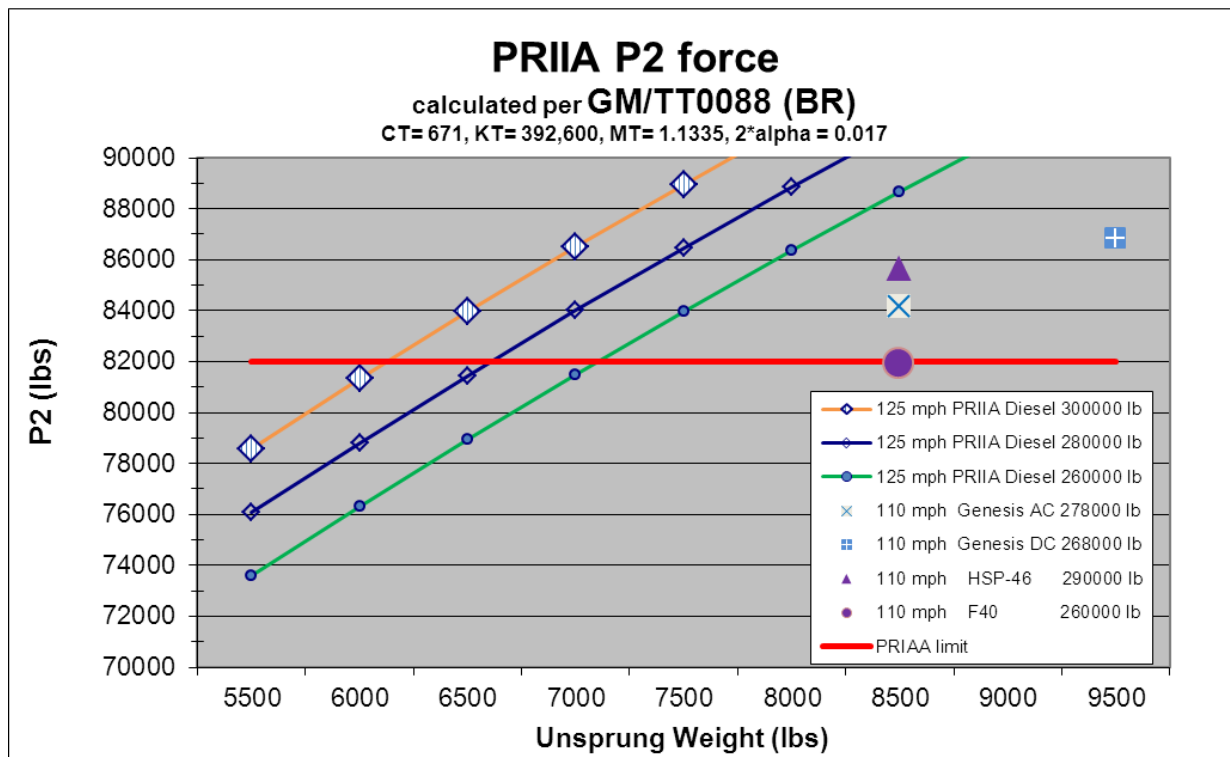

**Figure 2.3.3-a: P2 force for PRIIA loco compared with existing diesel rolling stock**

Amtrak currently utilizes both AC and DC Genesis, while MBTA will soon be taking delivery of new HSP-46 AC locos. These locomotives can be operated at a maximum of 110 mph while PRIIA locos are expected to run at 125 mph. Figure 2.3.3-a shows that by utilizing the weight ranges described in the previous section for both the locomotive overall weight and the unsprung weight along with the track parameters provided in the PRIIA 305-005 specification, the existing locomotives do not meet the PRIIA P2 force limit even at the slower operational speed of 110 mph. Historically, Amtrak has used the F40 locomotive as a baseline for P2 force calculations. It appears from the figure above that the current P2 force limit is based on the P2 force generated by an F40 loco operating at 110 mph. It should be clear that future PRIIA locomotives weighing 260,000 lbf (F40), or more, will need an unsprung weight of approximately 7000 lbf, or less, to stay below the P2 force limit. This likely includes all conceivable future PRIIA locomotives.

So, the obvious question is “What unsprung weight can be tolerated for a given locomotive weight?” Since the PRIIA standard provides no guidance for benefits of P2 forces lower than the limit, it is reasonable to assume that, at least from design standpoint, it is sufficient to only meet the specification rather than attempt to exceed it. Given the current technology and challenging design tradeoffs facing North American locomotive builders, just meeting the minimum requirements will be difficult and expensive.

For purposes of analysis then, it makes sense to calculate the maximum allowable unsprung weight that will result in a maximum P2 force of 82,000 lbf for a given locomotive weight. Figure 2.3.3-b, does this for 125 mph operation using the PRIIA track parameters.



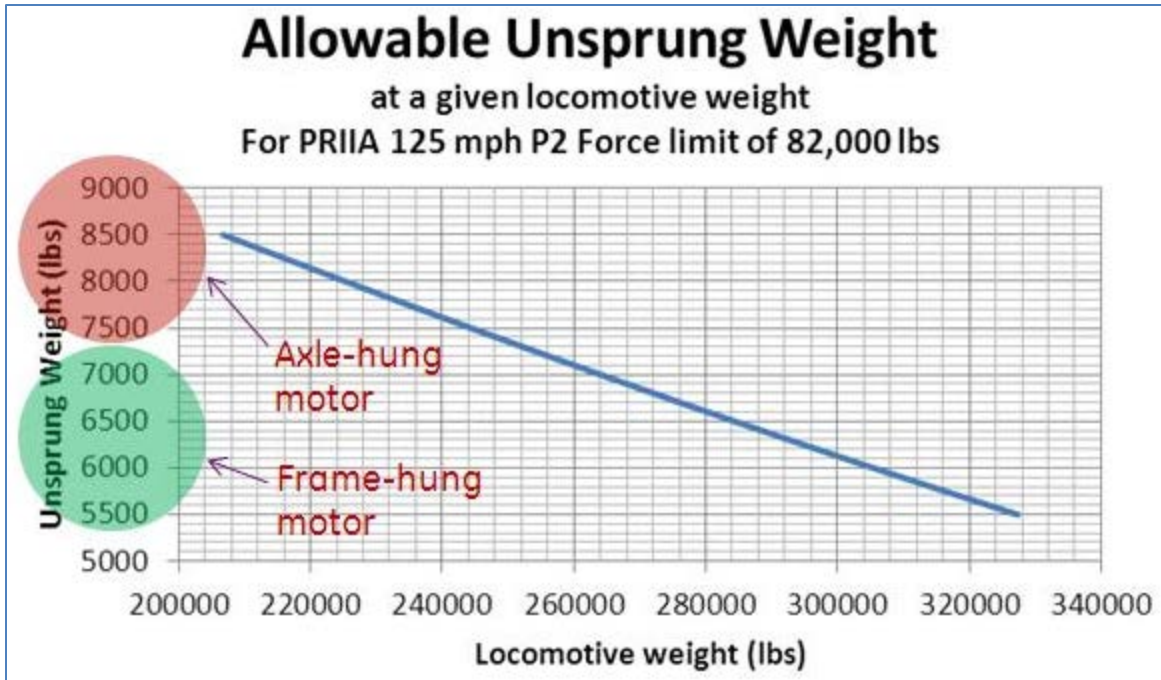

**Figure 2.3.3-b: P2 force for PRIIA loco: Loco Weight versus unsprung weight, 125 mph**

Closer inspection of this chart suggests that if the lightest unsprung weight for an axle-hung motor design is 7500 lbf, then the overall locomotive weight needs to be approximately 244,000 lbf. This is not considered a likely solution, as there is currently no viable concept for a diesel powered, Tier 4, and crashworthiness compliant locomotive that can achieve such a light weight.

As discussed in Task 4 of this study, it is likely that because of the higher braking energy requirements, the new heavier and faster PRIIA locomotive will need to add a disc brake system to the tread brake system currently already on typical U.S. passenger locomotives. On an axle-hung design, this addition will further increase the unsprung mass, causing the P2 forces to increase beyond the values of existing stock. This further adds to the need for an even lighter locomotive.

Based on the preceding, we conclude that the next generation 125 mph passenger diesel will have to use frame-hung motors in order to reduce the unsprung weight.

#### Class 6 or Class 7

The target speed of 125 mph can only be achieved on class 7 track. Currently, class 7 track in the United States is limited to short sections in the North East Corridor. The fastest diesels are limited to 110 mph on class 6 track. There is some belief in the industry that due to lack of infrastructure, the PRIIA specification should be tailored to 110 mph operation, or phased in later as high-speed infrastructure becomes available. If this were the case, and the P2 force limit was maintained at 82,000 lbf, then Figure 2.3.3-b could be modified for 110 mph operation. Now, as shown in Figure 2.3.3-c, an axle-hung traction motor design becomes more plausible. Of the locomotives compared previously in Figure 2.3.3-a, only the 260,000-pound F40 locomotive meets the P2 limit, even at 110 mph.

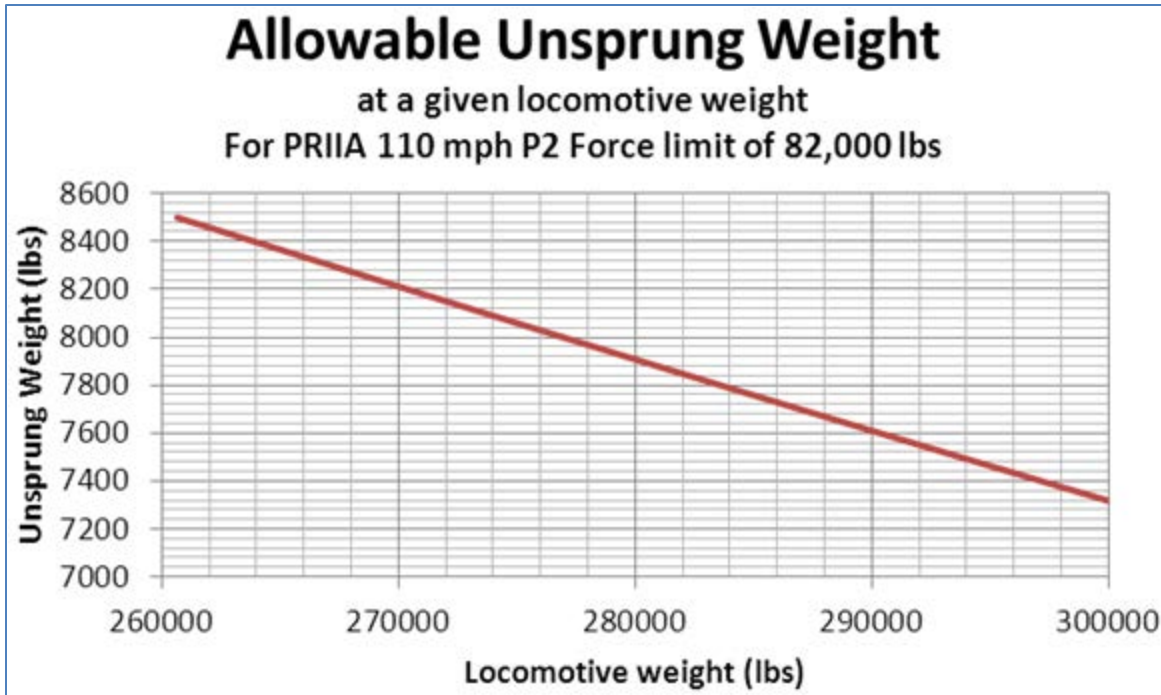

**Figure 2.3.3-c: P2 force for PRIIA loco: Loco weight versus unsprung weight, 110 mph**

In light of the earlier conclusion that an axle-hung motor design is not conceivable for a 125 mph locomotive, the remaining comparisons will assume that an axle-hung motor design is based on a 110 mph locomotive. For tracking purposes, this locomotive will have 260,000 lbf overall weight with 8,500 lbf unsprung weight, just like the F40.

Note that the F40PH has a horsepower rating of 3200 while the PRIIA locomotive power requirement is estimated to be as much as 4500 HP to achieve and maintain 125 mph. This will almost certainly result in a heavier engine and engine support systems.

### **Effect of track parameters on P2 force**

The previous section discussed the effect of locomotive parameters on P2 force. It may be of interest to compare the effect of locomotive weight and unsprung weight with the effect of track parameters that impact P2 force: Dip angle, track mass, stiffness, and damping. Different values have been used over the years and so it is important to understand the effect of changing these values.

#### *Dip Angle*

The dip angle selected in the PRIIA specification is 0.0085 radians. It could be argued that this is a conservative number especially for 125 mph operation on class 7 track. Regardless, other publications use both higher and lower values ranging from 0.003 to 0.01. Higher values of dip angle have a tendency to increase the P2 force.

#### *Effective Track Mass*

The effective track mass in the PRIIA specification is 1.1335 lbf-sec<sup>2</sup>/in. This value is consistent with track made with concrete ties. Values in literature range from 1.1335 to 2.592 lbf-sec<sup>2</sup>/in. Higher values of track mass have a tendency to reduce the P2 force.

### Effective Track Stiffness

The effective track stiffness in the PRIIA specification is 392,900 lbf/in. This value is defined as a value for track made with concrete ties. Upon closer inspection, this value appears to be somewhere in between values for wood and concrete ties used in the past by Amtrak.

Values used in the past have been in the 265,000–650,000 lbf/in range for wood and concrete tie tracks, respectively. Higher values of  $K_t$  have a tendency to increase the P2 force.

### Effective Track Damping ( $C_t$ )

The effective track damping in the PRIIA specification is 671 lbf-sec/in. This value is two to five times higher than values used in the past. Values used in the past were 121 to 205 lbf-sec/in. The example in the GMTT/0088 is  $55.4 \times 10^3$  Ns/m which is equivalent to 316 lbf-sec/in. Higher values of  $C_t$  have a tendency to reduce the P2 force.

Figure 2.3.3-d shows a Main Effects plot derived from 729 combinations of 6 parameters, each of which has three levels ( $3^6=729$ ). The P2 force is calculated for 125 mph operation. The center value for each parameter is the PRIIA value while the other two enveloping values are from the ranges described above. (For parameter symmetrical ranges, the center point will lay on the red dotted line which represents the 82,000 lb, while unsymmetrical ranges like the dip angle and  $C_t$  will have the center point offset from the line even though those center points represent the limit.) By utilizing the ranges described above for each parameter, it becomes clear that the dip angle has the most far reaching effect on P2 force on the track side, while unsprung weight is the parameter to optimize on the vehicle side.

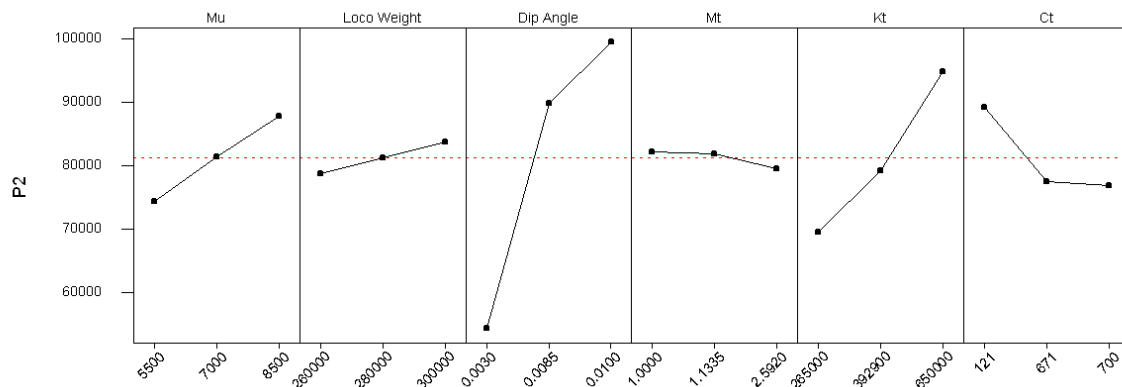

**Figure 2.3.3-d: Main Effects plot for parameters used in the P2 Force equation for 125 mph operation**

Tracks with concrete ties will have more mass and may exhibit more damping, but will also be typically stiffer than tracks with wood ties.

It is reasonable to assume that the dip angle will vary with class of track due to tighter geometry standards, with smaller angles on higher classes of track. As such, perhaps it is worthwhile to compare the P2 forces exerted by a given vehicle on class 7 track at 125 mph with class 4 track at 80 mph. Figure 2.3.3-e shows such a comparison where classes of track correspond to the maximum allowable speed and the rail joint dip angle gets smaller as the track gets better.

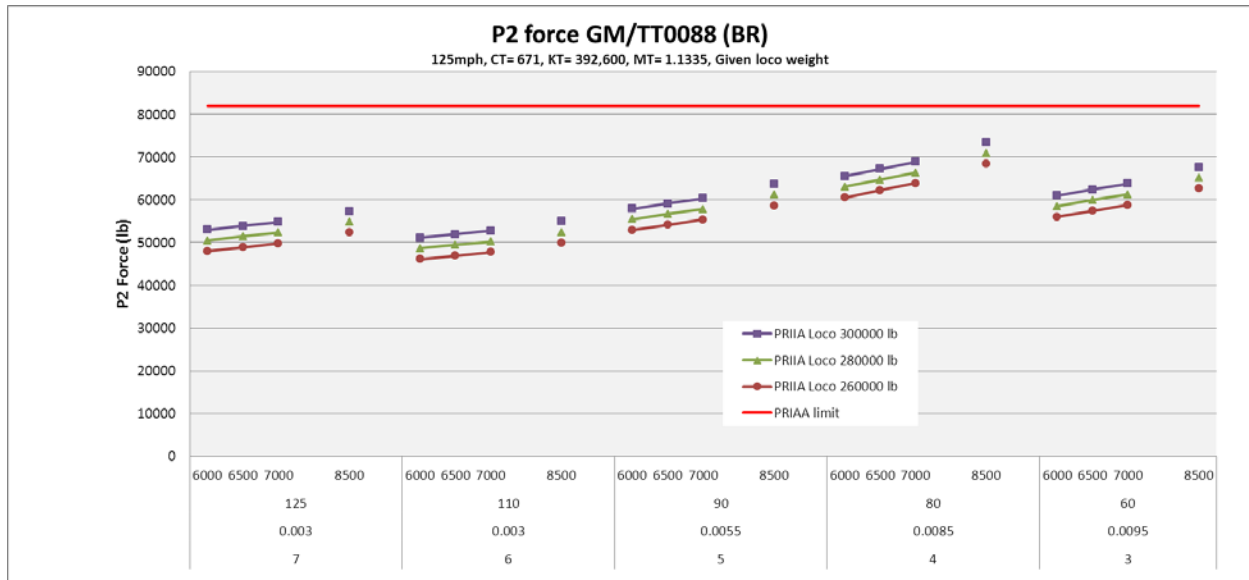

**Figure 2.3.3-e: Comparison of potential P2 forces on different classes of track**

Assuming that class 6 and class 7 tracks are dedicated for passenger transport, it is conceivable that these tracks could be maintained to higher track standards. If this were the case, operation on class 4 track, at 80 mph, could produce values higher than the high-speed operation. Since class 4 track is most likely going to be shared by freight traffic, it is reasonable to want to understand which type of vehicle will produce higher P2 forces.

The comparisons in Figures 2.3.3-f and 2.3.3-g below are based on the following locomotive configurations:

<u>Loco</u>	<u>Overall Weight (lbf)</u>	<u>Unsprung Weight (lbf)</u>	<u>HP (reference)</u>
F40	260,000	8,500	3,200
Genesis DC	268,000	9,500	4,250
Genesis AC DM	275,000	8,500	3,200
GE EVO DC Freight	436,600	10,725	4,400
HSP-46	290,000	8,500	4,650
PRIIA Axle-Hung (110 mph)	260,000	8,500	4,500
PRIIA Frame-Hung	285,000	6,500	4,500

Keep in mind the following comparisons are for purposes of analysis and discussion of options. The authors do not know of a viable path to reduce the PRIIA locomotive weight, with crashworthiness structure and Tier 4 engine components included, down to 260,000 lbf.

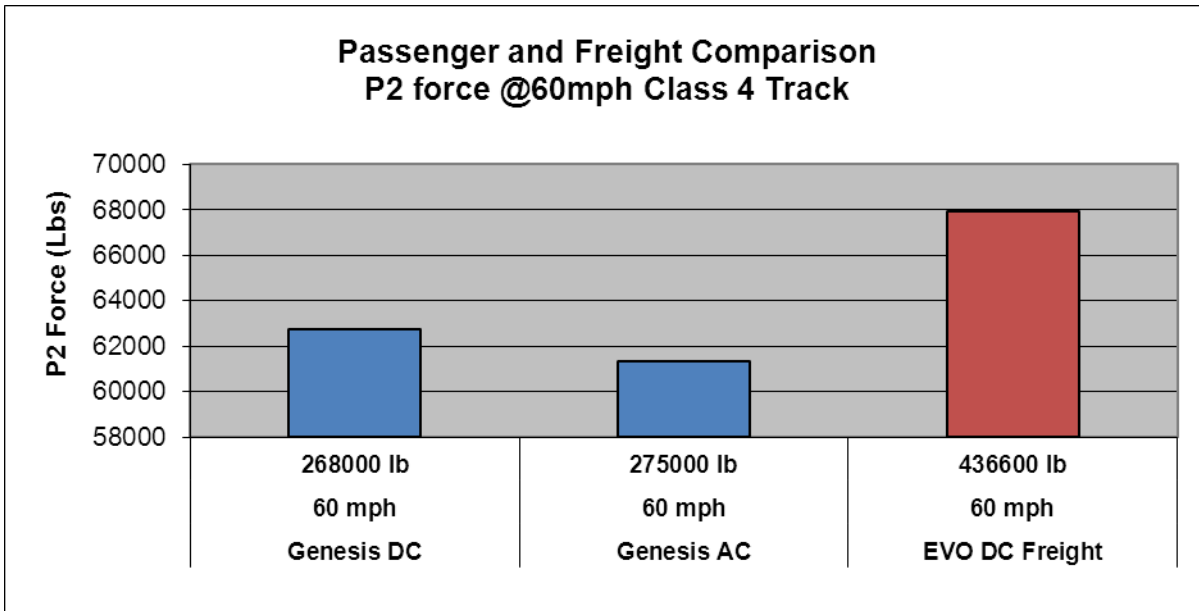

**Figure 2.3.3-f: Comparison of P2 forces on class 4 track, at 60 mph, for freight and passenger locomotives**

Figure 2.3.3-f shows that at the same 60 mph speed, both of the AC and DC Genesis units, because of their lower weight, have lower P2 forces than the heavy-haul Evolution freight locomotive. But maximum speed for passenger vehicles is higher than for freight vehicles so a comparison should be made at the maximum speeds allowed.

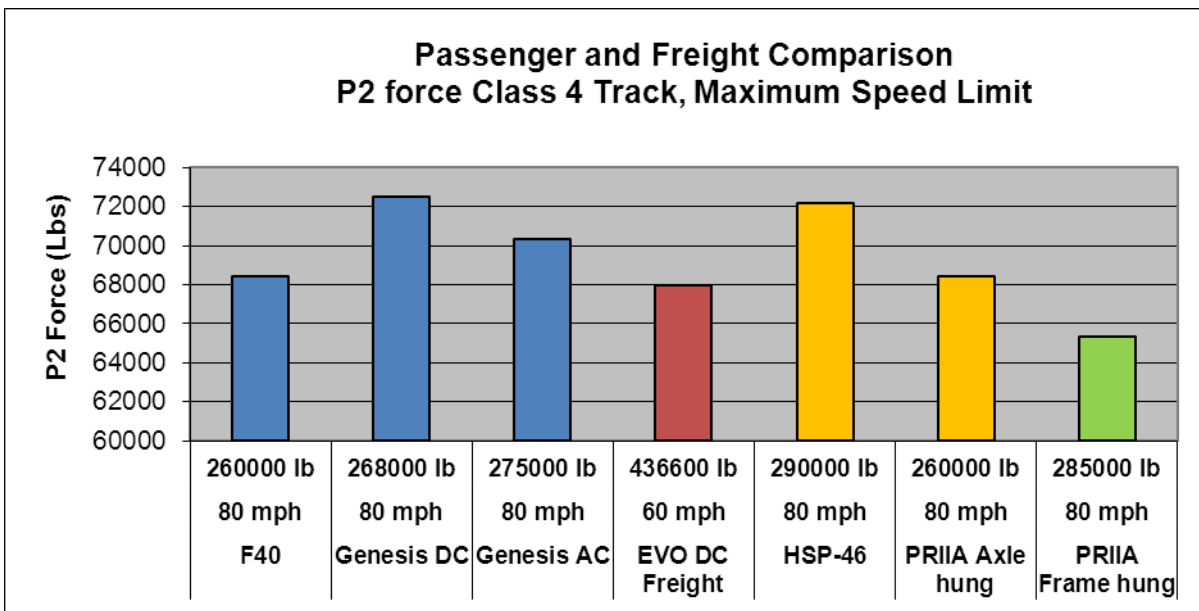

**Figure 2.3.3-g: P2 force – passenger versus freight for Class 4 Track operation**

Figure 2.3.3-g shows that passenger locos with axle-hung traction motors exert higher P2 forces than freight locos on the same track, mostly due to differences in operating speed. The new

PRIIA locomotive with axle-hung motors will be better than the old Genesis because the AC motor is lighter than the DC motor, resulting in lower unsprung weight. The overall loco weight would have to go down to 256,000 lbf on the axle-hung design in order to match P2 forces generated by heavy haul freight locomotives. In contrast, the 125 mph frame-hung motor design exerts lower track forces on class 4 track than the 110 mph axle-hung motor design, as well as lower forces than the freight locomotive. This further reinforces the conclusion that frame-hung motors will be required on passenger vehicles to meet the PRIIA specifications. This will also be true at 110 mph. As stated above, we do not know if a viable path exists to reduce the PRIIA locomotive weight, with crashworthiness structure and Tier 4 engine components, to below 260,000 lbf. At this time, it seems certain the next generation PRIIA certified locomotive will weigh considerably more than 260,000 lbf.

### **2.3.4 Conclusions and Recommendations (P2 force analysis)**

The current PRIIA P2 force specification uses F40 as a baseline locomotive. This locomotive has a relatively lighter 3200 HP engine and also light locomotive weight of 260,000 lbf. The Genesis locomotives, which make up the bulk of the Amtrak diesel fleet, are 4000HP to 4200HP (P40 and P42, respectively) and weigh 268,000 lbf. These locomotives will not meet the PRIIA required 82,000 lbf limit at 125 mph, nor at 110 mph.

Locomotive builders can influence two of the six parameters (not including speed) that affect P2 forces, total locomotive weight and unsprung mass. Total weight is likely to increase, despite manufacturers' efforts to lighten the total vehicle. In order to meet the new crashworthiness and emissions standards, as well as achieve the higher horsepower required to reach 125 mph, the new PRIIA locomotive will likely be heavier than the Genesis. This places additional pressure on reducing unsprung mass. We conclude that a frame-hung traction motor design will be required to limit the P2 force to 82,000 lbf on the next generation passenger locomotive.

### **2.3.5 Lateral track shift force**

Regarding lateral track shift force evaluation, Task 2 of this report included the track shift force evaluation [Figures 2.2.3-j (g) and 2.2.3-j (h) in Task 2] for a specific high-speed condition of a 1.1 degree curve at 125 mph. This evaluation shows that the most sensitive parameters, the most notable being yaw damping, are those which affect dynamic behavior. At higher speeds, dynamic effects begin to dominate the classical quasi-static behavior associated with curving analysis in tighter curves at lower speeds. Additionally, worn wheels, which tend to create more flange clearance and result in lower forces in tight curves, will drive the opposite effect at high-speeds, making the vehicle less stable.

The original intention for this section was to piggyback off the Task 2 analysis to draw conclusions about the effect of suspension design on track panel shift forces. During the Task 3 analysis it became apparent that the limitations of the analysis in Task 2 also prevent an adequate exploration of this topic in Task 3. Additional analysis was performed to explore the question about performance in tighter curves, and although all simulation resulted in values that were below the proposed limit for Net Axle L/V, the analysis failed to sufficiently drive a conclusion or any recommendation and therefore was not included in this report.

As frame-hung motor designs enter the market, they affect either wheelbase or car body connection designs because the distance between the traction motor and the wheel set increases

compared with axle-hung traction motor designs of the same capability. These changes play a role in the overall dynamic performance of the vehicle and performance of the track (lower panel shift forces).

A recommendation for future work in this area is to explore the effect and interactions of wheelbase changes, car body connection type (traction pin versus traction link), and suspension design. The impacts of these design tradeoffs should be evaluated across a wider range of curvatures, including those utilized by freight traffic, as well as with new and worn conditions of wheel and rail profiles.

## **2.4 Task 4—Braking Capability Summary Report**

### **2.4.1 Definition**

Braking capability is a critical safety factor for a high-speed passenger locomotive. As operating speed increases, designing and packaging the brake components becomes more challenging. The energy that must be absorbed and converted to heat by the brake system increases with the square of the velocity. The need to absorb this additional energy necessitates adding material and weight to a bogie system that, in order to reduce P2 forces, requires a reduction in total weight and/or unsprung weight.

Task 4 evaluates brake design requirements and likely characteristics of a brake system for a PIIA specified diesel passenger locomotive operating at up to 125 mph.

### ***Current Design Trends***

Rail vehicles in North America primarily use air operated tread brakes in which the brake pad is applied directly to the tread of the locomotive or car wheel. Locomotives generally combine dynamic braking (DB) with the friction tread brakes, reducing the amount of thermal energy the friction brake must absorb. However, safety regulations require that the locomotive be able to make an emergency stop utilizing air brakes only. This study evaluates the requirements needed to meet the air brake only case, with no DB contribution.

Brakes convert kinetic energy into heat and the tread brake applies this heat directly to the wheels. At higher speeds, the wheels can reach temperatures which can change their metallurgical structure, resulting in wheel cracking and other wheel defects. Although transformation temperatures are above 1,300 degrees °F, generally, for design purposes, temperatures have been limited to something less than 1,000 degrees °F. To reduce wheel defects, this limit should be even lower. Since today's existing rolling stock already reaches these temperature limits, in order to ensure acceptable braking temperatures, tread brakes must be supplemented, or replaced, by other means.

DB has been used on diesel locomotives for over 50 years with good success, but always as a secondary system which supplements the critical air operated friction brake. The friction brake system has to be designed to provide sufficient retardation for emergency stop, though such stops are very rare. From a duty cycle standpoint, DB still plays an important role in emergency stopping and its inherent wheel slip control provides opportunity for braking optimization.

In Europe, China, and Japan, disk brakes have been used extensively, especially on high-speed trains. However, there are major differences between those vehicles and the one required for PIIA. The most significant difference, of course, is weight, which requires larger discs on the heavier North American locomotives, further feeding the vicious cycle of performance strength and weight. Performance drives large traction motors which occupy space between the wheels, leaving little to no space for axle mounted disc brakes. Heavier locomotives drive higher dynamic track forces which force the use of frame-mounted traction motors. This in turn creates the need for a flexible coupling between the traction motor and the wheel set, again adding weight to the vehicle. All this makes it difficult to simply replace tread brakes with disk brakes.

### ***Diesel Locomotive***

The diesel locomotive uses a diesel engine to produce electricity, which in turn is used to power electric traction motors. Although, originally, DC motors were applied to locomotives, AC



motors have slowly become more popular, mostly due to absence of ground brushes which wear over time and need to be replaced. New generation passenger units will utilize AC traction motors. Compared to an electric-only locomotive, the diesel engine and its support systems, such as cooling and lube oil, can double the total locomotive weight.

***Comparison between passenger and freight***

The differences in operating characteristics between passenger and freight diesel locomotives dictate differences in design requirements. Freight operations vary from heavy haul (coal, iron ore, etc.), which is typically lower speed and tighter curves, to intermodal (general merchandise, mail, etc.), which is generally faster—up to 80 mph in the United States—and with less tight curves. In short, freight locomotive bogies are designed to provide the maximum pulling capacity for the train, while retaining the ability to traverse tight curves.

Passenger locomotive bogies are ideally designed to operate at higher speeds with less emphasis on the ability to pull long trains with many trailing tons. The objective is generally to pull six to eight cars filled with passengers to keep scheduled arrivals and departures. In the U.S. Amtrak environment, of course, the truck and locomotive must be designed to operate on all classes of track and speeds, not just at high-speed and higher class tracks.

Passenger Rail can be divided into commuter (< 50 mi) and intercity. Commuter trains make many stops while intercity make fewer. The duty cycle for the passenger locomotive braking system is very different from the freight duty cycle.

***Comparison between European and North American passenger***

The North American Passenger Diesel locomotive will be twice as heavy as its European counterparts, due to infrastructure differences, crashworthiness requirements, and the heavy diesel engine.

Europe has by far the most densely populated rail network in the world and utilizes passenger rail on a much larger scale than North America. Figure 2.4.1-a shows a map of rail network density around the world.

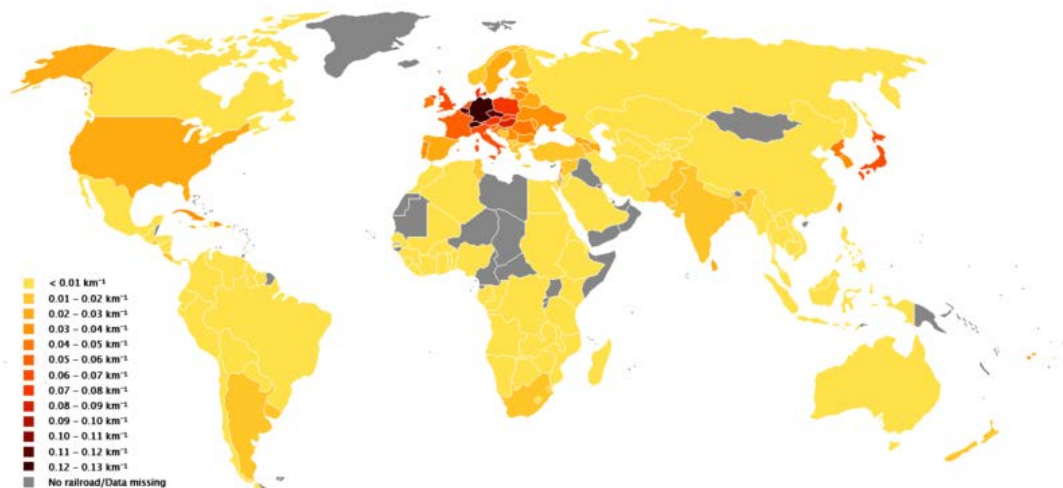

**Figure 2.4.1-a: Rail network divided by area of the country**

While the United States has more miles of track than any other country, this track is primarily built and used for freight service. The rail infrastructure limits freight traffic to 80 mph and

passenger traffic to 90 mph. Several special corridors exist where the rail infrastructure is dedicated to passenger service and allows speeds up to 110 mph. There are a few relatively short sections that are electrified with the infrastructure to support speeds up to 150 mph (ACELA). Prior to World War II the United States had electrified over 20 percent of its rail network, but today electrification is limited to the North East Corridor and some metropolitan areas like New York City and Chicago.

In contrast, almost 50 percent of Germany's rail system is electrified. This allows use of EMU which has advantage over head-end-powered trains because it distributes the required train power across more vehicles and more axles. With respect to truck design, electrification enables use of smaller traction motors which results in lower vehicle weight and lower unsprung weight.

### ***Existing 125 mph head-end diesel locomotives***

So where is there a precedent for 125 mph service for a head end diesel locomotive? Prototypes of Spanish Talgo XXI and Russian TEP80 locomotives were built but never mass produced. British Rail Class 43 HST is the only diesel put into actual service and still running today.

Though 197 units were produced, these units have some major differences from the proposed PRIIA locomotive. The units weigh less than 155,000 lb (17.5 metric tons per axle) thanks mostly to a lightweight high-speed engine and lack of current FRA crashworthiness requirements. As a result, less energy is required to stop the Class 43 HST than is required to stop its future U.S. counterpart.

In the United States, NJT has purchased 26 APL-45DP (dual mode) locomotives which weigh 288,000 lbf (33 MT) and are the best example of a working configuration for North American passenger locomotives. Though they operate at only 100 mph in diesel mode, they are capable of 125 mph in electric mode. These units utilize both tread brakes and disc brakes and this section of the report describes in some detail why that is the case.

### **2.4.2 Approach**

The Task 4 study compares braking energy needs for the PRIIA locomotive with other existing rail vehicles in North America and Europe. Additionally the task uses prior work (Gordon and Orringer) in the area of wheel heating to make comparisons between the vehicles used in that study and the future PRIIA locomotive, as well as between existing freight and passenger diesel locomotives.

### ***Braking Energy Fundamentals***

The basic premise of a locomotive air brake is that the kinetic energy of the moving vehicle has to be converted to friction heat. As such, one can calculate the kinetic energy of a vehicle based mainly on its speed and mass since Kinetic Energy (KE) is:

$$KE = \frac{1}{2} mv^2$$

Where

m = mass of the vehicle

v = vehicle speed

## Heat Flux

Knowing the total kinetic energy that needs to be converted to heat is not enough to predict wheel temperatures. Number of wheels, wheel diameter, and brake shoe width determine how much surface area will be used to absorb the heat. The rate of application will determine the power going into the wheels while the surface area will allow conversion of this power into heat flux. Figure 2.4.2-a shows the approach undertaken in this paper.

### Gordon/Orringer Study on Arrow-III cars

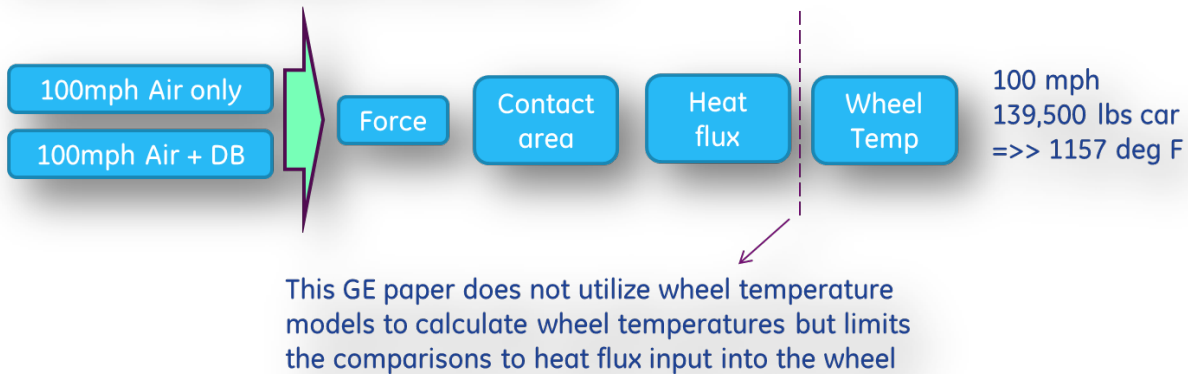

**Figure 2.4.2-a: Approach for utilizing the Gordon and Orringer study to draw conclusions about brake requirements on PRIIA locomotive**

The existing Gordon and Orringer research is extrapolated to reach conclusions about the braking considerations for the new PRIIA diesel locomotive. This research utilized a finite element thermal model to predict wheel tread temperatures based on some given heat flux input. Although the maximum wheel temperature depends on the rate of heat flux input, since deceleration rates are typically controlled for passenger comfort (1.6–2.0 mph/s) and since the highest heat flux will occur at the highest speed, calculating the maximum heat flux still allows the reader to draw the same conclusion.

The focus of this portion of the study is on brake energy dissipation and heat flux input. No actual wheel temperatures were calculated, as that is beyond the scope and funding of this report. It is felt that the earlier benchmarking sufficiently drives the conclusion.

While we believe that the general conclusions drawn here are well founded, more detailed analysis and calculations could provide valuable insight into specific design parameters and details that will have to be met and provided in a working system. This could be a helpful area for additional study.

## 2.4.3 Results

### 2.4.3.1 Brake Energy

#### Passenger versus Freight

Though modern freight locomotives are always heavier than their passenger counterparts, they may also have more axles and operate at lower speeds. As the kinetic energy calculations below

in Table 2.4.3-a indicate, freight locomotives require less total energy dissipation per locomotive. When the higher number of axles is taken into account, the difference is even more significant on an energy per wheel basis.

**Table 2.4.3.1-a: Comparison of Kinetic energy between Freight and Passenger locomotives**

	Weight, max	Number of Axles	Speed, max	Kinetic energy
Freight locomotive	436,600 lbs	6	80	127 MJ
Existing Passenger locomotive	278,000 lbs	4	110	153 MJ
PRIIA Passenger locomotive	285,000 lbs	4	125	202 MJ

Typical freight locomotives weigh less than 420,000 lb and travel at speeds below 75 mph. Figure 2.4.3-a shows that, compared with the typical freight locomotive, the 125 mph PRIIA loco has to dissipate twice as much energy per wheel when stopping from maximum speed. The figure also shows O&G Arrow-III, a passenger car from NJT used in the Gordon and Orringer study discussed later in this section.

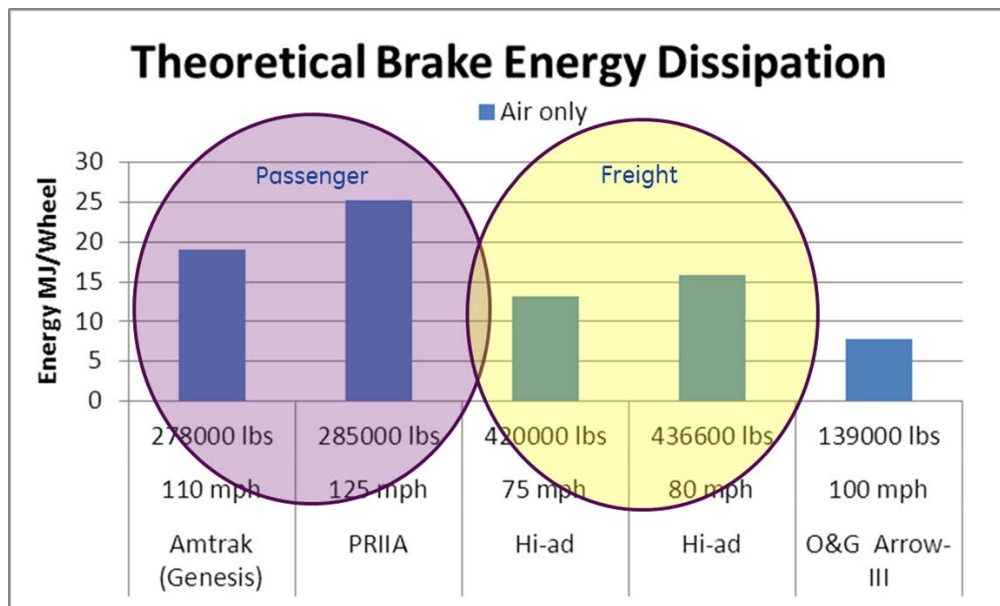

**Figure 2.4.3.1-a: Energy absorbed by each wheel for passenger and freight locomotives**

### European versus NA passenger

European locomotives in general are lighter, faster, and typically set up in distributed power rather than head-end power. For a closer comparison, it is useful to consider existing diesel locos which run at 125 mph. One such loco is the British Rail Class 43:

[http://en.wikipedia.org/wiki/British\\_Rail\\_Class\\_43\\_\(HST\)](http://en.wikipedia.org/wiki/British_Rail_Class_43_(HST))

Still, even this diesel unit is considerably lighter than the North American locomotives. Utilizing the same approach shown in Table 2.4.3-b, it is no surprise that the North American units, which are almost twice the weight of their UK counterparts, will need almost twice the braking force since kinetic energy is directly proportional to the weight of the vehicle.

**Table 2.4.3.1-b: Comparison of Kinetic energy between Class 43 and P11A locomotives**

	Weight, max	Number of Axles	Speed, max	Kinetic energy
UK – Class 43	154,280 lbs.	4	125	109
North America – P11A Loco	285,000 lbs.	4	125	202

It is clear that North American and European operations are quite different. Technology used in Europe is not directly applicable to North America. In addition to the huge difference in axle load, there is also a difference in track quality, which leads to a fundamental difference in suspension design approach. In Europe, the standard is to provide a relatively stiff primary suspension and a relatively soft secondary suspension. In North America, which is dominated by freight traffic, an alternate approach consisting of a relatively soft primary suspension and a considerably stiffer secondary suspension has been adopted. The soft primary suspension is more adaptable to rough track sections, while the stiff secondary helps with weight transfer, which is important in heavy haul applications. This arrangement performs relatively well at slow freight speeds but at higher speeds may not be the optimal solution. This topic is covered in section 2 of this report.

#### **2.4.3.2 Comparison of brake types and thermal dissipation**

The general premise of any braking system is that the kinetic energy of the speeding vehicle must be converted to heat. This is typically done via friction brake or through DB, where the electricity produced by the traction motors working in DB mode is directed into resistor grids which dissipate the heat away from the wheels.

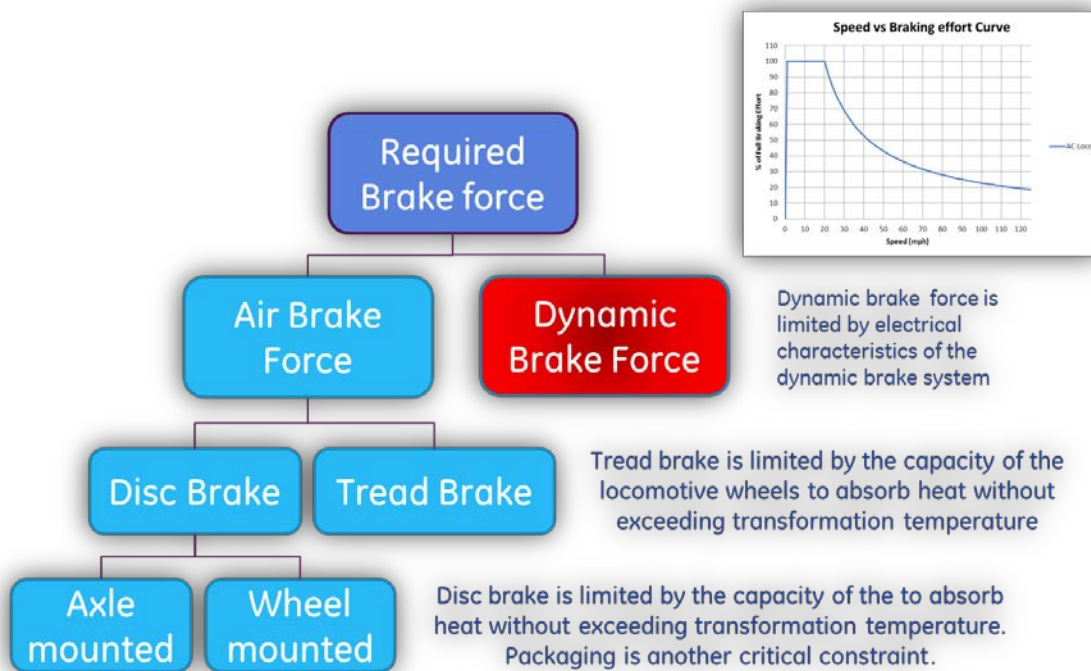

**Figure 2.4.3.2-a: Locomotive brake types**

### Tread brakes

Tread brakes are pneumatically (air pressure) powered and are the most common method of stopping railway stock. Friction material in the form of a brake shoe is applied directly to the tread of the wheel, thus creating a retarding force directly at the wheel. One benefit of tread brake use is that it “conditions” the tread of the wheel, or to put another way, cleans it.

The downside of this brake configuration is that the dissipated heat is mostly transferred into the wheel. Though quite acceptable at lower speeds typically found on freight service, for passenger operation, as speeds rise, so do the temperatures, and when the temperatures reach beyond 800 °F, the wheels begin to run the risk of experiencing metallurgical changes which generally have a negative impact.

Wheel defects are a big concern for any railroad since broken wheels cause delays and may be a precursor to derailment. At higher speeds, consequences of derailment grow exponentially, especially on passenger trains.

Generally, the Association of American Railroads (AAR) defines several classes of wheels, with softer wheels aimed at high tread brake applications and harder wheels at low tread brake applications (AAR M107/M208). There is evidence that harder wheels are more resistant to rolling contact fatigue (RCF) which generates micro cracks in the tread surface of the wheel and, if gone unchecked, can develop into shattered rims.

Over the last decade, the railroads have been replacing their tracks with harder rail and also harder wheels, partially due to these findings on RCF.

## Disk Brakes

Disc brakes come in several varieties based on where they are applied in the drivetrain. The rotor can be mounted directly on the locomotive axle, it can be housed around the web of the locomotive wheel, or it can reside on a dedicated shaft which is connected to the axle through a gearbox. The obvious benefit of a disc brake is that it reduces the thermal load on the wheel and typically provides a larger surface area for heat dissipation. Conversely, it is typically harder to package and increases not only overall weight but, more importantly, the unsprung weight (in the case of axle and wheel mounted rotors). On diesel locomotives, the traction motors are typically large so space is at a premium.

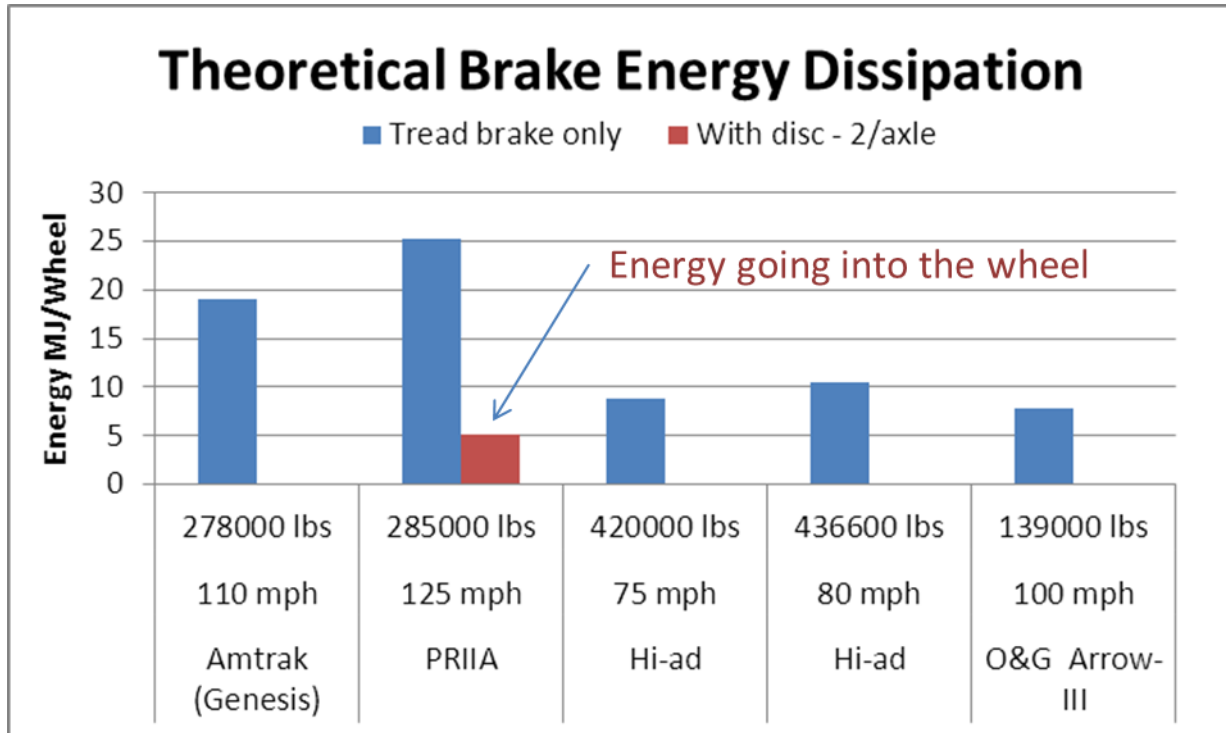

**Figure 2.4.3.2-b: Locomotive wheel energy reduction resulting from disc brake use**

Figure 2.4.3-c above compares braking energy absorbed by the wheels for a number of relevant applications. The blue bars are for the case of tread brake only. Note that the PRIIA application has the highest braking energy due to its higher speed. The red bar for that case shows the energy going into the wheel for the case of tread brake combined with disc brake.

## Dynamic Brake

DB has gained popularity over the years, especially on AC locomotives which provide additional capability at lower speeds. Traditionally, DB was used as an auxiliary brake which reduced the demand on the friction brakes. Today it is still used in this fashion, but has gained more acceptance in the industry as a primary means of slowing down freight locomotives. Though freight locomotives generally have separate controls for dynamic and “air” brakes, certain passenger locomotive models utilize “blended brakes” where the operators only have a single control for the locomotive brakes (on top of the train line brake, which controls the brakes on the entire train). Figure 2.4.3-d shows that even though the air only operation has high energy dissipation demand on each wheel on the passenger application, when blended brakes are utilized



the demand goes down below typical freight locomotive levels. This explains why the existing passenger Genesis units can utilize tread brake only solution at 110 mph. Even so, although emergency braking happens rarely, and the likelihood that DB failure will occur during an emergency application from 110 mph is remote, it is conceivable that such operation could induce some damage to the wheels, especially if one focuses only on the brake energy required.

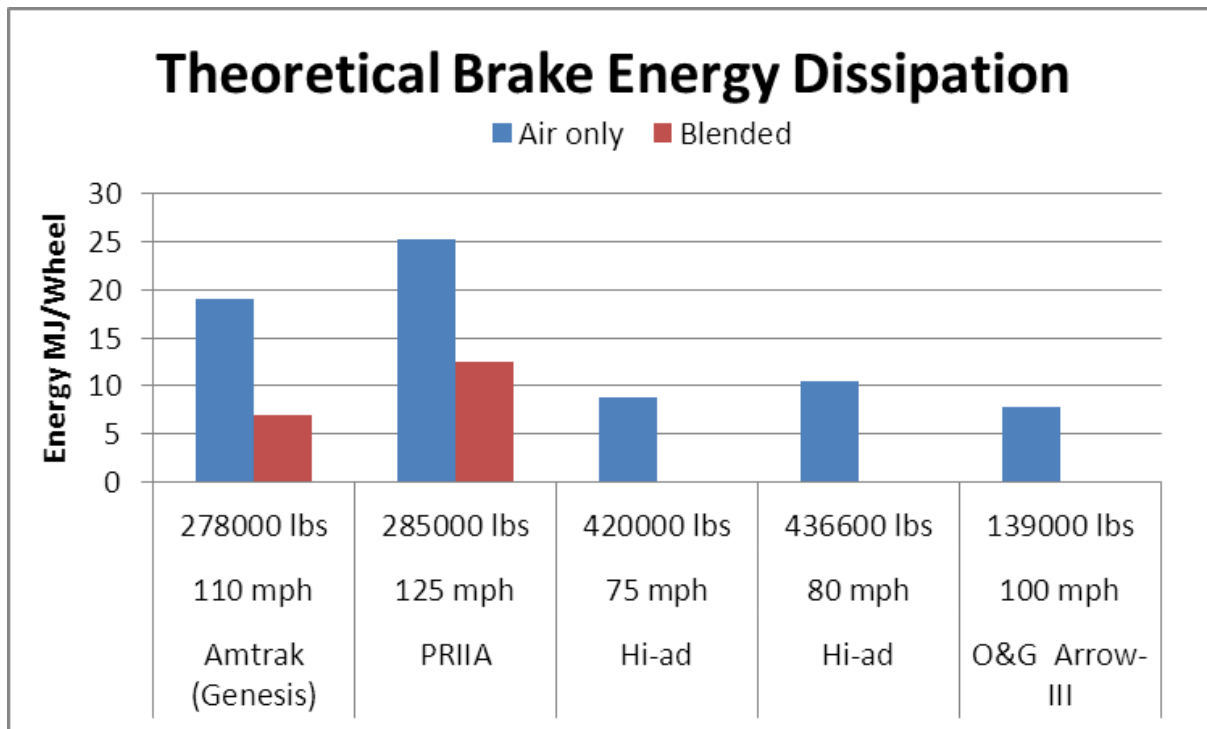

**Figure 2.4.3.2-c: Locomotive wheel energy reduction resulting from use of blended brake**

### Estimate of potential wheel damage from braking energy

It is beyond the scope of this paper to utilize finite element modeling to predict wheel temperatures under passenger applications. Instead, an alternative approach is used to draw conclusions without actually calculating the temperature. In 1995, Gordon and Orringer wrote a paper dealing with wheel heating on New Jersey Arrow-III cars, where they did utilize a finite element model to predict wheel temperatures. The Arrow-III cars are multiple unit powered cars which distribute traction and braking to multiple axles in the train consist. During the conversion from DC to AC motors, the railroad decided to reconfigure each married pair of cars to have three powered trucks and one unpowered truck, meaning that the powered trucks had DB and the unpowered truck did not. The study focused on increase in operation speed from 90 mph to 100 mph and evaluated impact of auxiliary brakes in the form of both disc brake and DB. One of the inputs to the model was the heat flux going into the wheel tread surface.

The study predicted temperatures of 945 degrees °F for braking from 100 mph on the unpowered truck and 1,157 degrees °F on the powered truck with DB disabled. When the brake was augmented by DB on three out of four trucks, the temperatures reduced to below 800 degrees °F. The tread brake retarding force at full brake pipe pressure is 7,000 lbf, However, the original configuration limited the retarding force to 5600 lbf. With the use of augmented auxiliary DB on three of the four trucks, it appears that the average retarding force from the tread brake was



reduced although the peak force at 100 mph actually went up. The DB provided 26 percent augmentation but was applied at a  $\frac{3}{4}$  ratio since only three of the four trucks were powered; in other words, the DB reduced the thermal strain on the wheels by 20 percent.

It is interesting to observe that the DB augmentation reduced the tread brake demand under normal operation, which naturally includes the use of DB in a blended mode; however, it obviously did not change the brake demand for air only emergency stop. This suggests that emergency stopping with air only was not the main driver for the design decisions at NJT. In fact, disc brakes were also evaluated and actually provided best reduction of thermal input into the wheels, including air only emergency stops, but in the end were not selected.

Regardless of the above conclusion, the Gordon and Orringer study can be utilized to extrapolate the expected heat flux for the future PRIIA locomotive. Heat flux for the given case is dependent on the brake shoe force and the contact area. As such, this approach is a better way of comparing demand for thermal dissipation in a brake system than simply looking at brake energy. Since the Arrow-III cars uses smaller diameter wheels and smaller shoes than those used on a diesel locomotive, the relative heat flux going into those wheels is actually higher. Table 2.4.3-c shows the comparison of parameters and relative heat flux between the Arrow-III cars and diesel locomotives.

**Table 2.4.3.2-a: Comparison of Heat Flux input between Arrow-III cars and diesel locomotives**

	Arrow-III	Genesis	PRIIA	Freight Hi-ad
Vehicle Weight (lb)	139,000	278,000	285,000	436,600
# of axles	4	4	4	6
speed (mph)	100	110	125	80
wheel diameter (in)	32	40	40	42
brake shoe width (in)	2.5	3.38	3.38	3.38
contact area (in <sup>2</sup> )	251	425	425	446
brake retarding force per truck (lb)	7,000	12,800	14,000	30,000
energy (MJ/wheel)	7.9	19.1	25.2	10.6
<b>energy ratio</b>	<b>1</b>	<b>242%</b>	<b>320%</b>	<b>134%</b>
heat flux (MW/m <sup>2</sup> )	2.147E+06	2.555E+06	3.176E+06	2.766E+06
<b>heat flux ratio</b>	<b>1</b>	<b>119%</b>	<b>148%</b>	<b>129%</b>

Table 2.4.3-c above compares diesel locomotives and the Arrow-III cars from the Gordon and Orringer paper. The diesels are represented by an Amtrak Genesis Dual Mode locomotive, the potential PRIIA locomotive as defined in section 3 of this paper, and a heavy haul GE ES44AC freight locomotive.

The Genesis Dual Mode unit is used in this example because it represents the heaviest Amtrak locomotive which operates at 110 mph. As such, it likely demonstrates the highest current braking demand for a diesel locomotive in the United States today.

The freight locomotive is included in this comparison because it represents the majority of the U.S. rail diesel traffic, or at least it represents the right tail of the distribution from a weight perspective. The speed of 80 mph is actually faster than the actual operating speed, as most railroads limit their traffic to 70 mph, and few attempt 75 mph. Because it is the speed limit for freight traffic on FRA class 5 track, 80 mph is used in this case.

Returning to the comparison in Table 2.4.3-c, the diesels are heavier and have larger wheels so they require more energy dissipation but have more surface area to distribute the heat. The passenger locomotives have a higher operating speed and higher weight, while the freight locomotive has more axles and larger wheels, but also has a much higher retarding force per wheel than the passenger units. This higher retarding force is made possible by the lower operating speed which keeps the heat flux in a workable range. Though freight locomotives do not utilize blended braking, they do have an independent DB.

The brake retarding force for the diesels was calculated assuming a coefficient friction of 0.4. Although slightly high, it does not impact the overall conclusion.

As discussed in the Gordon and Orringer paper, the maximum wheel temperature is reached early in the braking event, before the locomotive slows down to 60 mph and below. It is therefore important to understand the highest values of heat flux which will occur at the highest speeds. Table 2.4.3-c compares the total energy required as well as the heat flux generated during initial brake application. Figure 2.4.3-e shows heat flux as a function of time during

emergency stop from 125 mph; this figure is similar to ones used in the Gordon and Orringer study.

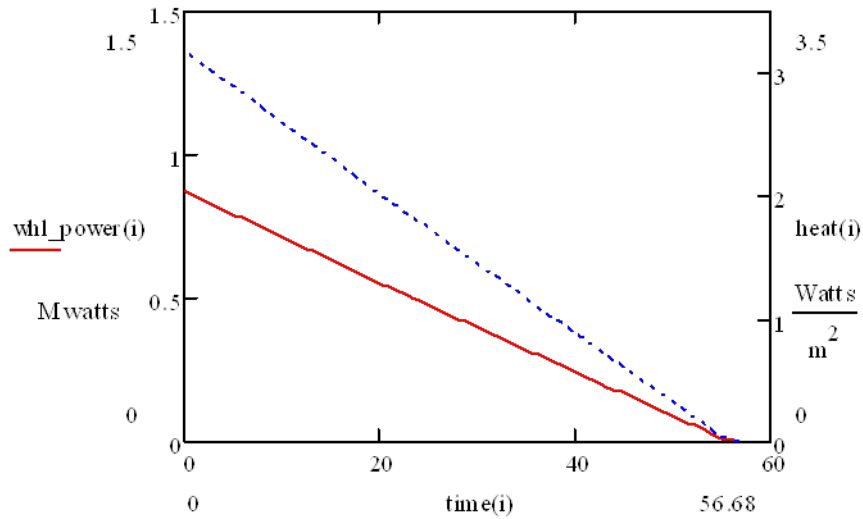

**Figure 2.4.3.2-d: Wheel power and heat flux for a 285,000-pound PRR locomotive in air-only emergency brake application based on approach used in the Gordon and Orringer study**

The resulting heat flux on the Genesis passenger and freight locomotives is higher than on the Arrow-III cars. The Genesis unit generates 119 percent of the heat flux produced by the NJT cars, while the PRR locomotive is likely to produce 148 percent. It is reasonable to assume that for “air only” emergency stop, the temperature would likely be even higher than the 1,100 °F observed on the NJT cars. Figure 2.4.3-f shows the heat flux and wheel temperature from the Arrow-III cars, as well as the expected temperature and the presumed heat flux of approximately 3 MW/m<sup>2</sup>.

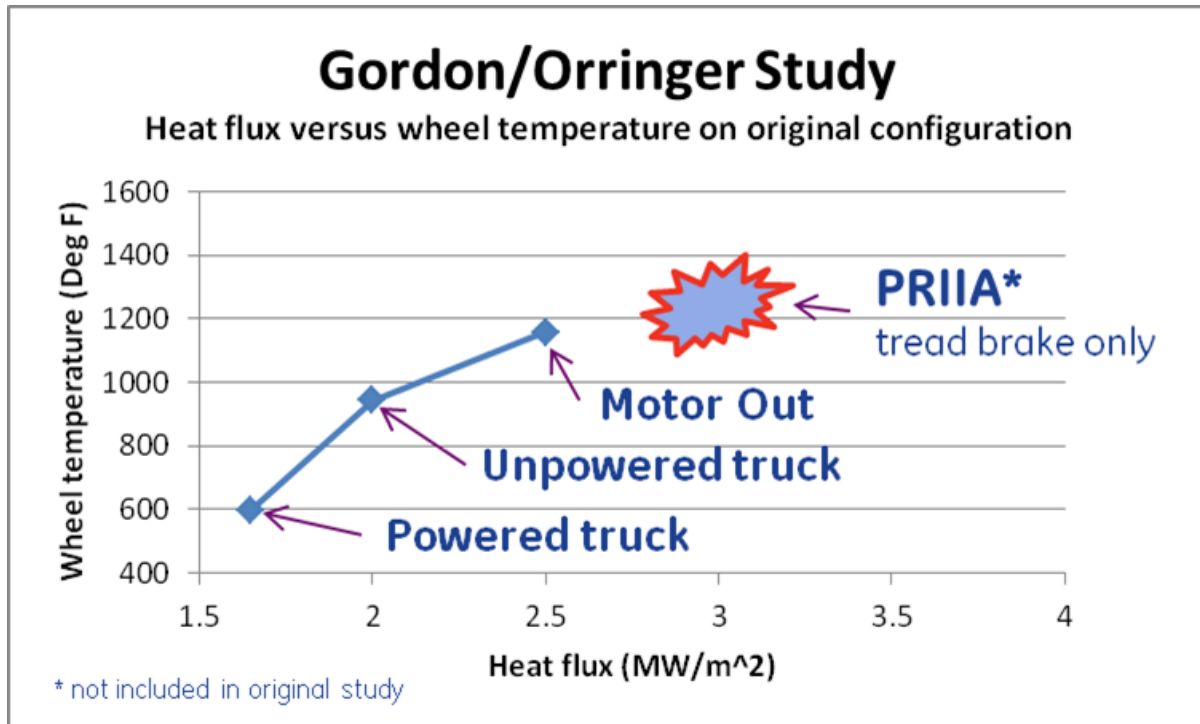

**Figure 2.4.3.2-e: Assessment of expected wheel temperature for a PRIIA locomotive utilizing tread brakes only in emergency stop from 125 mph, based on the wheel temperatures from the Gordon and Orringer study**

Though this does not appear to be an issue on the existing Genesis fleets (likely due to the blended braking), the PRIIA locomotive would likely push the temperatures towards the transformation temperatures and increase chances for the formation of untempered martensitic structure which is brittle and can break out of the wheel tread surface. In most cases, the blended brake operation will drive the temperature to less than half that value.

The PRIIA locomotive, stopping from 125 mph, will generate heat flux higher than 3 MW/m<sup>2</sup> with 40-inch wheels—and as a result, higher wheel tread temperatures. It is true that increasing wheel diameter will reduce the heat flux, in this case 60-inch wheels would match the heat flux in the Arrow-III cars, but that would likely still produce temperatures above 1,000 °F.

#### **2.4.4 Summary**

Braking energy is a function of the locomotive mass and square of the velocity. Increasing speed from 100 mph to 125 mph increases brake demand by 56 percent ( $125^2/100^2=1.56$ ). Additionally, the new Tier 4 emissions standards combined with crashworthiness standards are expected to result in an increase of mass in the new passenger locomotives compared existing locomotives. With this additional brake demand, air only braking can no longer rely solely on tread brake as this type of configuration would drive wheel temperatures beyond 1,000 °F, which is a major contributor to wheel tread cracks. As concerns over RCF continue to push specifications for harder wheels, it becomes more important to reduce the thermal load on wheels through the auxiliary brake systems.

When comparing passenger and freight thermal dissipation needs, it becomes obvious that the operating speed is the main driver for the difference in these two operations. Since kinetic energy is a function of velocity squared, the energy dissipation needs at 125 mph become significantly higher: three times more kinetic energy at 125 mph on a PIIA locomotive as opposed to 70 mph on a typical freight locomotive. Approximately the same ratio is reflected in Figures 2.4.3-c and 2.4.3-d.

As much as speed is the main driver in the comparison between freight and passenger operations in North America, comparisons with Europe make weight the clear differentiator. Lower weight in Europe means lower braking demand. Use of distributed power typically in the form of EMU and DMU allows the use of smaller traction motors or, in some cases, motors on just some axles, which frees up more space for disc brakes. On axles with no traction motors, three to four rotors can be placed on a single axle, thus eliminating the need for tread brakes.

In normal braking situations, the DB will carry a sufficient portion of the brake load to adequately offload the heat input into the wheels from the tread brake. For safety reasons, DB is still considered a secondary system, meaning the vehicle must meet stopping distance requirements while utilizing only air brake.

Based on weight, performance, and packaging constraints on the PIIA locomotive, the disc brakes alone system is impractical. It would need to dissipate 50 percent more energy than currently used arrangements and as a result would need to occupy considerably more space. Removing tread brakes would also mean that the wheels lose the benefit of being cleaned by the tread brake shoe.

#### **2.4.5 Conclusions and Recommendations**

The new PIIA Diesel Locomotive designed to operate at 125 mph will need to increase the number of braking systems from two to three. All three of the following systems will be required:

1. Tread Brake – currently used on Amtrak Genesis
2. Dynamic Brake – currently used on Amtrak Genesis
3. Disc Brake – currently not used on Amtrak Genesis but used on NJT APL-45 Commuter

The new PIIA passenger diesel loco will have both tread and disc brakes as a primary brake system but will rely on DB to reduce thermal input into wheels and disc brakes.

Because heat input into the wheels and brake discs is dependent on the duration and frequency of application, it may be helpful to define a braking duty cycle for the PIIA locomotive. This area has potential for much debate between designers when one considers the impact that DB has on the air brake demand. The air brake has to be designed to stop the locomotive during emergency in case of DB failure without sustaining damage to the equipment. But how many times does it have to do this? Indefinitely? How often should emergency brake be applied consecutively? Considering the time it takes the train to get up to speed, it should be several minutes, but how likely is that scenario? It may be worthwhile to explore the tradeoff between cost of replacing damaged rotors or wheels in the unlikely event of multiple emergency stops with no DB against the cost of designing and maintaining a brake system which can sustain indefinite emergency applications with no DB.

There is evidence that the railroads may prefer a simpler brake system that is capable of stopping the train safely in the few rare instances that, for whatever reason, DB may not be available. NJT appears to be one of these railroads, considering that it chose not to install disc brakes which would reduce wheel temperatures even in the air only emergency brake application. Experience may suggest that emergency braking should be defined as a one-time occurrence as related to energy absorption and thermal calculations. Typically, commuter train duty cycles are the most demanding, from heat generation standpoint, because of the relatively short distances between their stops, but an intercity train may not be subject to such demand. Therefore, utilization of the same brake equipment as on commuter trains may lead to unnecessary locomotive weight increases and complexity. Standardizing these design inputs may allow more optimal designs and ensure a consistent safety margin among designers.

## **2.5 Task 5—Wheel and Axle Summary Report**

### **2.5.1 Definition**

The axle is a critical component in a high-speed bogie system. Axle failures could result in derailment. Axle reliability is therefore essential to the safe operation of a high-speed bogie. In addition, the axle mass comprises a significant proportion of a rail vehicle's "unsprung" mass. As previous sections have discussed, unsprung mass has a key influence on a rail vehicle's dynamic axle loading and is of particular significance during high-speed operation.

A significant amount of effort has been directed towards axle design for rail vehicles in high-speed service with the objective of reducing axle mass without compromising reliability. This survey reports on some of the major areas that impact high-speed truck safety and performance.

### **2.5.2 Approach**

This study evaluates several key areas of current axle technology and the design of safe high-speed applications. Some key global design practices are compared with the U.S. approach, particularly in areas that impact axle weight and size. As in Task 1, major design approaches are summarized but with a more specific focus on axles. Inspection and material technologies, where known, were included. Certain key design and material approaches are discussed in more detail, again, in just those areas that have the biggest impact on the size and weight of axle design.

### **2.5.3 Results**

#### **Axle Design Trends in Existing High-Speed Applications**

There are a number of locomotive applications in Europe, Japan, and China, which safely operate at speeds of 125 mph and above. A data set was developed to study the characteristics of those applications, and in particular, the application parameters that are relevant to the axle design. These parameters include vehicle speed, static axle load, unsprung mass per axle, the configuration of the wheel set in the bogie, what axle technology is employed, and what type of inspection technologies are employed, if any.

The data set in Table 2.5.3-a demonstrates that most high-speed applications have a static axle load of 22 MT or less, and the fastest applications limit axle loads to 13 MT. One notable exception is the Bombardier ALP 45 DP which can operate at 200 kph (125 mph) in electric mode, with an axle load of 32.66 MT. While actual figures for unsprung mass and specific details of the axle design are typically unavailable, it is certain that most manufacturers are developing configurations designed to minimize unsprung mass through the use of fully suspended drive systems or truck frame suspended motors with axle-hung gearboxes.

**Table 2.5.3-a: Matrix of High-Speed Locomotives Applications and Relevant Application Data**

Company name	Type of application	Axle/Bogie design	Material Technology	Inspection technology	Unsprung mass
Bombardier	ALP 45 DP – Diesel Electric Axle Load : 32.66t Max Speed: 210kph (electric) 160kph (diesel)	Bogie designs same as ALP-46 bogie with changes in axle size & other components. Fully suspended drive (ALP 46-A). 4-axle loco. Hollow axles designed with EN13103 (trailer) and EN13104 motorized). <b>Quill design.</b> Axle-hung & nose suspended drive Axle design: UIC A4T	A4T steel 24 CrMo 5	Alternating Current Field Measurement (ACFM); Advanced eddy current inspection; UT Phased array with 3-D imaging. <b>Tecnatom</b> has supplied automated axle inspection system to bombardier. Also, developed UT data analysis software. <b>Standard:</b> M-101/90-A (USA)	Possible ways for reducing unsprung mass from this company strategy. Laterally suspended axles. Suspending TM on truck. Traction rod minimizing load transfer b/w axles. Soft vertical and lateral suspension provides low lateral and vertical forces.
Alstom	Prima II Axle load: 22.5t Max Speed: 200 kph (Passenger); 140kph (Freight); 120kph (HD freight) Bo-Bo (86-90t); Co-Co (129-135t)	Axle-hung nose suspended traction motor.  Collaboration with <a href="#">Euraxles</a> for innovative axle designs and protection.		Estimating POD from response versus size method. Size measured by Alternating Current Potential Drop (ACPD), Phased array UT, TOF diffraction.	
Siemens	Axle load: 21.5–22t Max Speed: 230kph (electric); 201kph (diesel)	Change in axle dimensions for next ICE3.ICE 3/Valero is <b>nose-suspended drive. Max axle load for ICE3 is 17t.</b>  Max speed: 330kmph		<b>Mechanized UT inspection.</b> Earlier inspection was done for every 3lakh kms (6months) to 60,000kms (6weeks) to now 30,000kms (3weeks). Periodic inspection helps to detect small cracks. <b>Standard:</b> EN13261-2004	
Hyundai Rotem	HEMU-400X Static axle load: 13t Max speed: 400km/h	Four axles powered by synchronous induction motors.			
Kinki Sharyo	Shinkasen Max axle load: 11.39t Max speed: 285kmph				



## Axle design standards and methodologies

Various axle design methodologies are employed throughout the world. In Europe, powered axles are designed in conformance with EN 13104 standard, and in Japan railway axles are designed according to Japanese Industrial Standard E 4502. North America does not have a design methodology standard to govern axle design practice. North American axle designers are currently tasked with the challenge of following prudent axle design practice in the absence of the guidance of a design standard.

Axle design standards consist primarily of three parts:

- 1) Input definitions, including axle loading assumptions
- 2) Calculation method of axle stress
- 3) Design limits

The design standards can have a significant effect on axle size and weight. There are significant differences between the European and Japanese standards discussed here and the known U.S. design practices.

### Axle loading definitions

Actual axle loading is a function of vehicle speed, track conditions, and vehicle architecture. Figure 2.5.3-a shows a comparison of the basic loading assumptions employed in European and Japanese axle design standards. Note that the European standard does not consider axle loading to be a function of vehicle speed. The Japanese standard utilizes multiple relationships for horizontal acceleration in order to provide different limits for different classes of track.

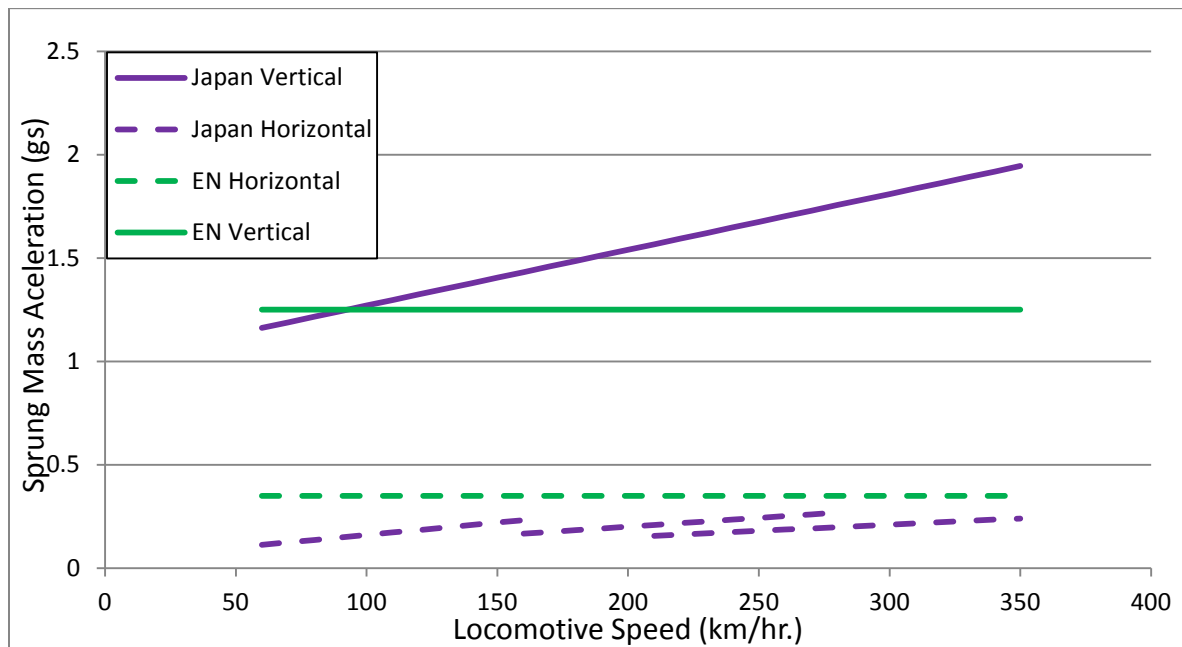

**Figure 2.5.3-a: Comparison of loading assumptions used around the world for axle design**

In U.S. design practices, the vertical axle loading component is considered to be solely a function of vertical car body acceleration. In international standards, the vertical loading component is

the summation of vertical car body acceleration and the vertical loading reaction loads from car-body roll resulting from horizontal acceleration. In the case of vertical acceleration, North American assumed stress is similar to the international design standards at speeds of less than 70 mph. At greater speeds, a very significant departure in design practice exists in North America, resulting in a much more conservative approach to axle design at speeds over 70 mph. This is in part because the slower speeds in North America have allowed such a conservative approach, but is primarily due to a lack of sufficient data to permit the proper characterization of axle loading based on the wide variety of North American track conditions and higher speeds. As North American applications reach higher speeds, dynamic loading from unsprung mass becomes increasingly significant. Maintaining such conservative design practices may result in unnecessarily heavy axle designs, with higher P2 forces as the penalty.

### Axle Material

One of the critical aspects of axle design is the material specification. Table 2.5.3-b provides a comparison of various standard axle material grades. Asterisk marks indicate the most commonly employed grades. Note that the various standards from around the world have converged on two general approaches to heat treatment, the first being a normalizing process and the second being quench and temper.

**Table 2.5.3-b: Comparison of Material Standards for Axles**

Standard Axle Grade	Processing	Selected Mechanical Properties			Selected Composition Data		
		Yield Strength (MPa)	Ultimate Strength (MPa)	Min. % Elongation	C	Mn	Si
AAR Grade F*	Double Normalized and Tempered	345	607 min	22	.45-.59	.60-.90	.15
AAR Grade G	Quenched and Tempered	345	586 min	19	-	.60-.90	.15
AAR Grade H	Quenched and Tempered	414	724 min	18	-	.60-.90	.15
EA1N*	Double Normalized	320	550-650	22	.40	1.20	.50
EA1T	Quenched and Tempered	350	550-700	24	.40	1.20	.50
EA4T*	Quenched and Tempered	420	650-800	18	.22-.29	.50-.80	.15-.40
GOST 31334 A1	Normalized or Normalized and Tempered	300	520-650	22	.40	1.20	.50
	Quenched and Tempered	350	550-700	24			
GOST 31334 A2	Normalized or Normalized and Tempered	360	600-750	17	.50	1.20	.50
	Quenched and Tempered	390	620-770	19			
GOST 31334 A3	Normalized or Normalized and Tempered	420	650-800	19	.40	1.60	.50
	Quenched and Tempered						
GOST 31334 A3	Normalized or Normalized and Tempered	420	650-800	19	.40	.80	.50
	Quenched and Tempered						

Higher strength alloy steels such as 30NiCrMoV12 have been successfully employed in high-speed applications in Europe. This material has a minimum ultimate strength of 932 MPa which permits a further reduction in axle mass, given similar loads.

Additional material processing has been employed in several applications to further improve the axle's fatigue properties. Examples of additional material processing include induction hardening, sub-critical quenching and cold working axle fillets. The most prevalent and successful example of additional heat treatment processing can be found on the Japanese Shinkansen bullet train network where axles have been induction-hardened since the network began service in 1964. Figure 2.5.3-b provides an illustration of the improvements in fatigue properties gained through the employment of an induction-hardening process vs. a quenched and tempered material.

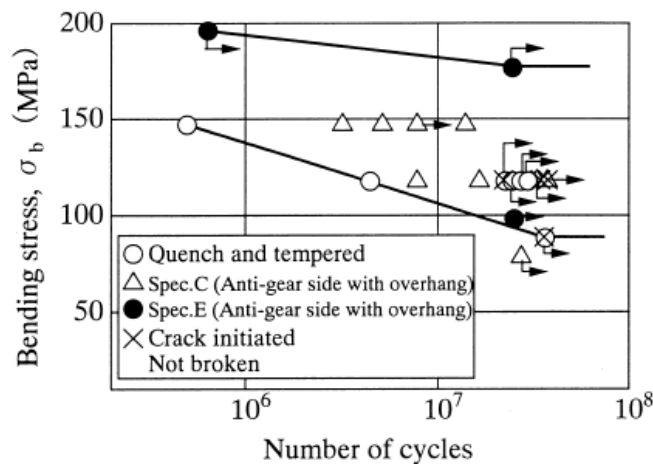

**Figure 2.5.3-b: Rotating bending fatigue tests for press-fitted axles (Spec C, E represent induction hardening processes)<sup>1</sup>**

European axle design standards permit axle designs to operate at a dynamic stress level approximately 20 percent higher by employing the quenched and tempered grade EA4T.

Improving material capability in high-speed applications enables lighter axle designs and thus is often employed in higher speed applications where unsprung mass is critical.

Figure 2.5.3-c below provides a comparison of standard steel grades used around the world and the alternating stress allowances permitted by the specified design standard of the region. The permissible alternating stress, as a proportion of alternating stress, decreases when quenched and tempered axles, as opposed to normalized axles, are employed. This results from an increase in notch sensitivity at higher strength, thus decreasing the realizable benefit from employing a higher strength steel alloy.

<sup>1</sup> K Hirakawa, K. Toyama and M Kubota, *The analysis and prevention of failure in railway axles*, International Journal Fatigue Vol. 20, No 2 pp.135–144, Elsevier Services Ltd. 1998.

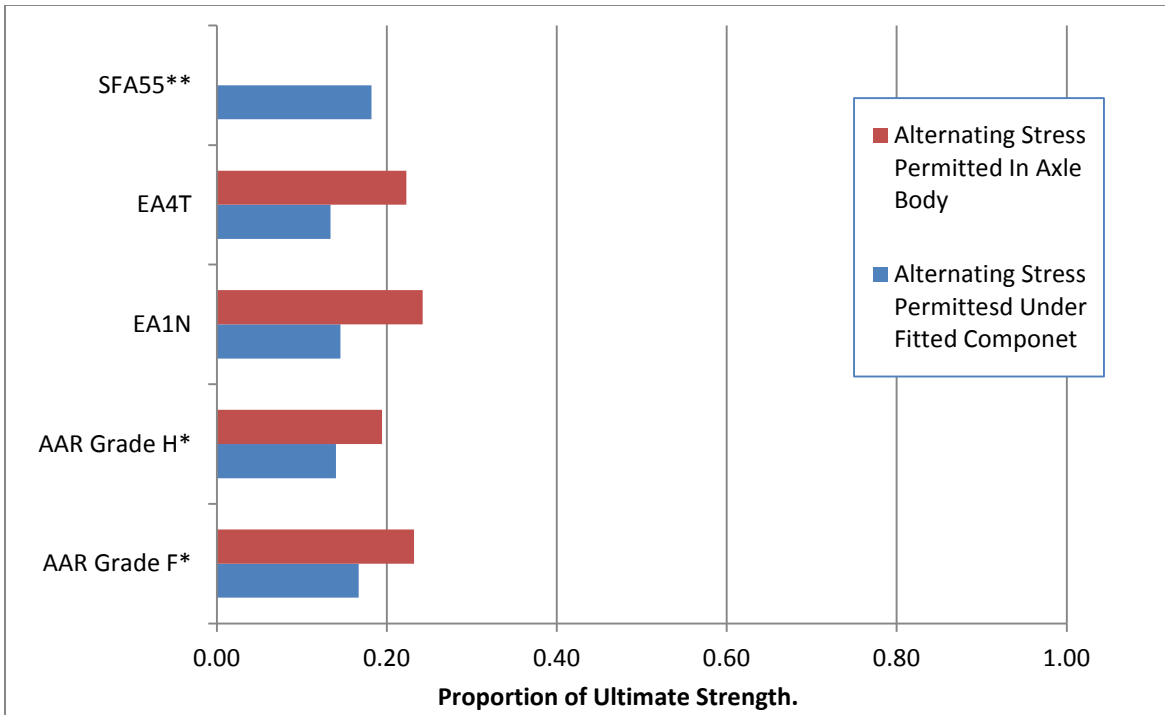

**Figure 2.5.3-c: Comparison of allowable alternating stress as a function of ultimate strength**

\*In the case of the AAR material grade, no corresponding design standard exists. Examples of known values used in U.S. design were input.

\*\*Source <sup>2</sup>

Figure 2.5.3-d illustrates the allowable axle stress in two categories: (1) the regions of the axle where the axle body is not in contact with a mating component and the main failure mode is bending fatigue, and (2) the regions of the axle located under a fitted component where fretting fatigue is the primary failure mode. Note a convergence with a relatively similar value for allowable stress from various sources around the world. Furthermore, it is interesting to see the difference in allowable stress in regions of the axle where components are fitted versus regions without a mating component. K. Hirakawa<sup>1</sup> and M. Kubota make the case that axle failure mode can be controlled simply with the axle geometry; a dataset in Figure 2.5.3-d presents an illustration of axle failure modes as a function of the ratio of the axle diameter under the wheelset versus the diameter in the axle body.

<sup>2</sup> K Hirakawa<sup>1</sup> and M Kubota, On the fatigue design method for high-speed railway axles, Proc Instn Mech Engrs Vol 215 Part F, IMechE 2001

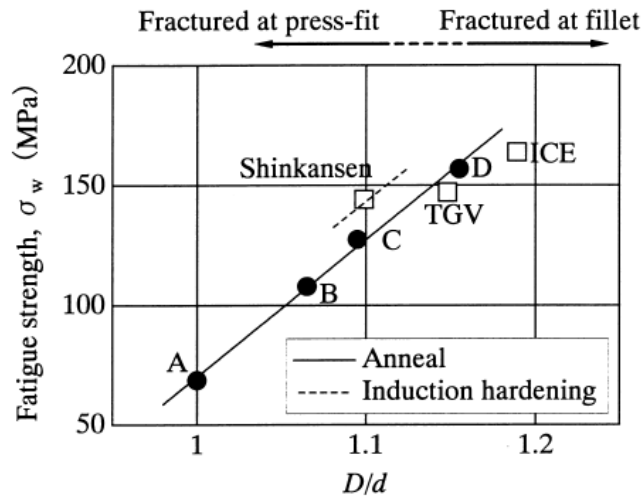

**Figure 2.5.3-d: Failure Mode as a function of wheel seat diameter ratio**

### Axle Inspection Technologies

Axle Inspection technologies are an important part of high-speed locomotive axle life cycle management. Table 2.5.3-a shows that many applications employ ultrasonic testing techniques while the axle is installed on the locomotive. Additionally, Japanese and European high-speed trains require wheel sets to be disassembled and a surface inspection to be performed at specified intervals.

Axle inspection procedures, the possible benefits, and impacts on cost are beyond the scope of this study. This is recommended as a possible area for further industry study.

### 2.5.4 Conclusions and Recommendations

Minimizing unsprung mass through the use of fully suspended drive systems or truck frame suspended motors is the trend in high-speed truck design. This study previously concluded that U.S. manufacturers will also have to follow this trend to achieve 125 mph for the next generation passenger locomotives. Reducing unsprung mass in this way leaves the axle mass as one of the more significant remaining portions of a rail vehicle's "unsprung" mass. Possible options to reduce axle weight should be considered and evaluated with sound engineering judgment.

Axle designers in North America may benefit by adopting a definition for axle loading similar to the one provided in the European and Japanese axle design standards in which axle loading is defined as a function of speed and track class.

Overseas methods to predict axle loading are generally less conservative than U.S. methods. The U.S. manufacturers could benefit from better high-speed loading data. Moving forward, the industry should consider developing and providing better design data in conjunction with industry design standards and methods, with the goal of providing efficient, safe, and reliable axles that may also reduce weight.

As more efficient axle designs are required due to higher speed applications in North America, axle designers should consider higher performance material and additional axle processing to

improve fatigue performance. As new materials are specified, the acceptable failure criteria may need to be carefully reviewed and changed as needed.

The North American passenger industry may need to consider adopting more advanced inspection capabilities similar to those employed by its global counterparts.



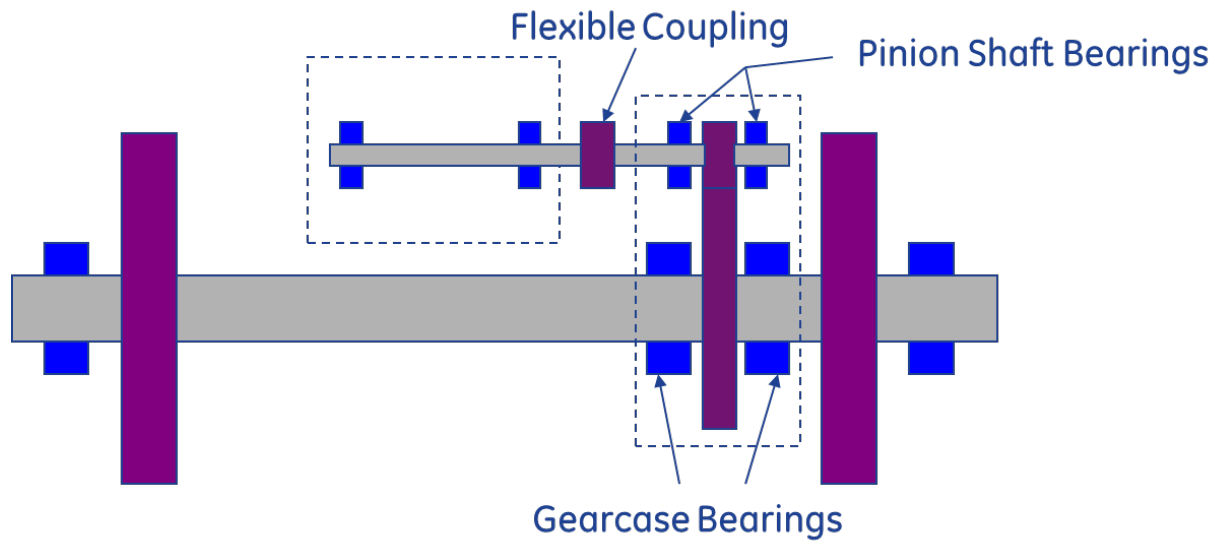

**Figure 2.6.1-b: Frame-hung motor HS coupling design**

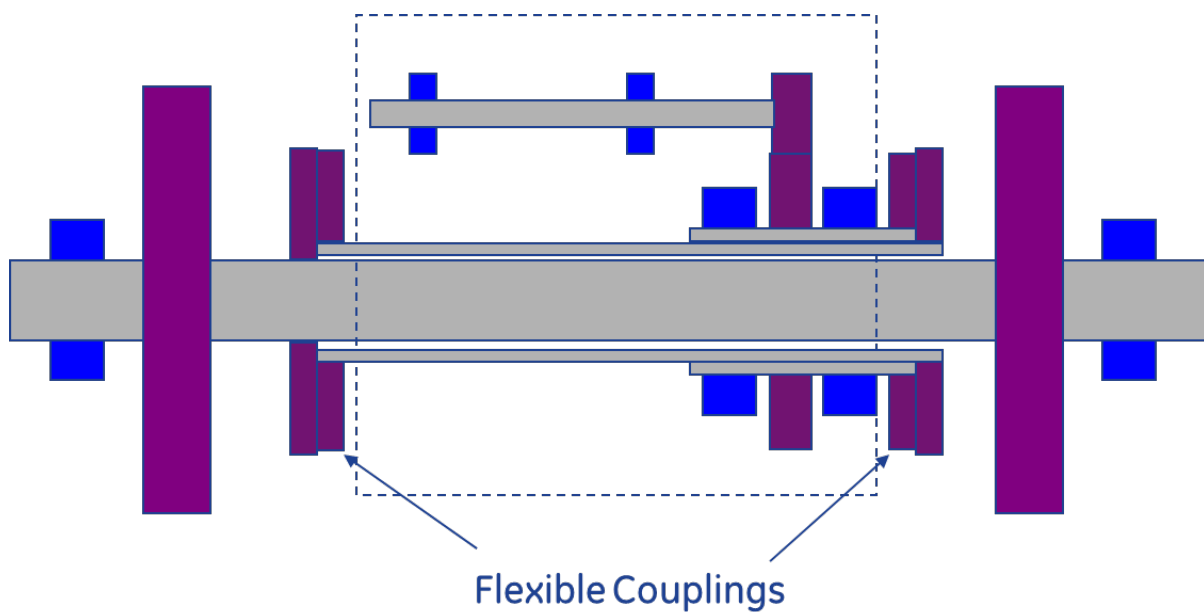

**Figure 2.6.1-c: Frame-hung motor LS coupling design**

### **2.6.2 Approach**

The approach is based on using Failure Modes and Effects Analysis (FMEA) methodology. GE Transportation assesses risk of a design using this method and specifically defines a safety risk using the severity score within this system. Although the FMEA also includes assessment of risk to reliability that includes scoring “occurrence” and “detection,” the reliability assessment was not considered a part of this study. Only the line items within the FMEA that scored high (9 or 10) on severity are discussed. Table 2.6.2-a shows the definition of the severity scores. Severity scores of 9 or 10 are consider safety risks; scores of 8 or below are not.



**Table 2.6.2-a: Severity Scoring Definition**

<b>Effect</b>	<b>Severity of Effect</b>	<b>Ranking</b>
<b>Hazardous without warning</b>	Potential failure mode affects safe system operation and/or involves noncompliance with government safety regulation without warning.	<b>10</b>
<b>Hazardous with warning</b>	Potential failure mode affects safe system operation and/or involves noncompliance with government safety regulation with warning.	<b>9</b>
<b>Very High</b>	System/item inoperable with loss of primary function, but safe. (Such as a locomotive mission failure)	<b>8</b>
<b>High</b>	System/item operable but at reduced performance level. Customer dissatisfied.	<b>7</b>
<b>Moderate</b>	System/item operable, but comfort/convenience item inoperable.	<b>6</b>
<b>Low</b>	System/item operable, but comfort/convenience item compromised.	<b>5</b>
<b>Very Low</b>	Defect noticed by most customers.	<b>4</b>
<b>Minor</b>	Defect noticed by average customer.	<b>3</b>
<b>Very Minor</b>	Defect noticed by discriminating customer.	<b>2</b>
<b>None</b>	No effect	<b>1</b>

Each design was evaluated as a drivetrain subsystem within the combo system. The drivetrain subsystem consists of components from the traction motor to the wheels. Five functions of the drivetrain subsystem were defined as follows:

- 1) Transmit tractive effort and braking torque from the motor and/or disk brakes to the wheels.
- 2) Operate for 20 year life and meet service reliability requirements.
- 3) Support the weight of the locomotive (wheel to axle to journal bearings into truck)
- 4) Transmit dynamic and steering loads (wheel to axle to journal bearings into truck)
- 5) Locate wheels and spacing

Within each of those functions, failure modes were defined and scored for severity using the scale listed in Table 2.6.2-a. Score levels for each failure mode were based on prior experience on North American freight and passenger locomotives.

Failure modes within the drivetrain system generally fall under failure or degradation of specific components within the drivetrain. Components that are not deemed as safety risks are grouped together within the FMEAs, and the specific components that result in safety risk are singled out with separate line items in the FMEAs.

### **2.6.3 Results**

Of the five functions listed above, 3 and 4 are the only two that were identified as leading to a potential safety risk. The other three functions had failure modes that would only result in reliability degradation and so they will not be discussed further in this report.

The wheels, axle, and main axle bearings are the drivetrain components used to support the weight of the locomotive and transmit dynamic loads as well as steering loads. In our experience, the failure of main axle bearings can lead to locked axles but does not cause derailment and has not been considered a safety concern. The two components of concern are the main axle and wheels. Failure of either of these two components could cause the loss of function to support the locomotive and result in an inability to transmit dynamic and/or steering loads to the truck frame. This failure could lead to derailment; the main axle and wheels are therefore considered safety critical components.

In the axle-hung motor designs for both freight and passenger rail applications, these components are flagged as safety critical components but have long standing controls such as internal design guides for axles and AAR certifications for wheels used in risk mitigation. Based on industry experience, the risk of failure of these components within their existing speed ranges is considered to be well understood.

As speeds increase and it becomes necessary to frame hang the motor, the next most cost effective design is to use a flexible coupling on the motor shaft line (Figure 2.6.1-b). Misalignment in the flexible coupling could result in additional risk to the drivetrain system through additional induced vibration and reliability of the coupling itself. Failure of the coupling would result in loss of tractive effort and possible locked axle, but the risk to wheel or axle shaft failure is deemed to be very low. There are additional reliability risks associated with a load bearing gear case and increased number of oil seals, but these components do not increase risks that would lead to wheel or axle failure.

As speeds increase even further, and the unsprung weight requirement is reduced, a frame-hung motor with a low-speed coupling design may be necessary (figure 2.6.1-c). Additional reliability risks were identified in the coupling and quill shaft, but additional safety risks are low. Low-speed coupling failure will result in loss of torque but not a derailment. Coupling or quill shaft failure could lead to contact with axle, but the operator has sufficient warning to avoid further damage. Additional inspection of axle shaft and wheels may be required in the event of coupling or quill shaft failure.

### **2.6.4 Conclusions and Recommendations**

Axle and/or wheel failure is the only traditional safety concern that could lead to derailment. Occurrence of axle failure has been historically low.

Locked axle has historically not led to derailment and, within the industry, has not been considered a safety concern.

For locomotive weight and speed combinations that are within the capability of the axle-hung and frame-hung high-speed coupling designs, specific additional safety requirements in the design are not currently recommended.

Additional reliability concerns may be associated with the high-speed designs, but with good design practice additional safety risk is low.

For frame-hung low-speed coupling designs, consideration for axle shaft and wheel inspection should be given in the event of coupling and/or quill shaft failure.

### 3. Report Conclusions

---

#### Summary:

An evaluation of bogie concepts for future high-speed passenger locomotives at speeds up to 125 mph was conducted. It was first necessary to define the U.S. operating conditions and requirements that will define the bogie design specifications. There are a combination of requirements and conditions that make the U.S. high-speed bogie application a unique design challenge. Specifically, the combination of high axle load with the PRIIA specification that limits the P2 force to 82,000 lbf, and the necessity to operate on all classes of track and speed ranges, result in difficult design-tradeoffs. Currently, no U.S.-based manufacturer can provide a truck that will meet the next generation passenger requirements.

The **Task 1** comprehensive global survey identified a number of dominant design trends in current high-speed bogies manufactured and operated in Europe, Japan, and China. The primary design characteristics are focused on two general areas: (1) reduction of unsprung mass and total weight in order to minimize P2 forces; and (2) optimization of stability, curving performance, and ride quality. All of the non-U.S. high-speed locomotives surveyed operate at 22 MT per axle, or less—much less than the anticipated 30–32 MT, or more, for next generation locomotives in the United States.

In **Task 2**, a truck and locomotive dynamics model was developed using ADAMS/Rail. From the global survey results, two likely truck design configurations were identified and described. The first of these, or Concept 1, was chosen as the configuration to be used in the Task 2 modeling analysis. Concept 1 includes a two-axle truck with Bo-Bo arrangement, frame-hung motor, fabricated frame, and a combination of both tread and disc brakes. MCAT track conditions for both straight and curved tracks were used with new and worn conditions for both wheel and rail. The impact and effects on safety related performance parameters of the truck suspension parameters were investigated using design of experiments and response surface methods.

To develop a feasible design space of possible suspension parameters, an optimization process, or design space method, was developed. This method successfully demonstrated that *a feasible combination of suspension parameters could be determined for the specific and limited truck configuration and conditions analyzed*. For a thorough analysis and actual design, more conditions and variables should be evaluated.

**Task 3** showed that in order to stay within the P2 force limit of 82,000 lbf, the *future PRIIA passenger locomotive trucks will have to incorporate a frame-hung motor to reduce unsprung mass*. No current U.S.-produced diesel locomotives can meet the limit at 125 mph. The relatively light F40 (260,000 lbf) will meet it at 110 mph, but not at 125 mph. Both the AC and DC motor versions of the Genesis locomotives exceed 82,000 lbf at 110 mph.

**Task 4** investigated braking requirements for a 125 mph passenger locomotive. Braking energy is a function of locomotive mass and speed. Increasing speed to 125 mph increases the amount of energy that must be absorbed by 56 percent. *To stop a four-axle high horsepower diesel locomotive from 125 mph will require an additional disc brake system combined with the already existing tread brake and DB system*. For the safety required case of air-only brake operation, neither a tread nor a disc brake system alone will be sufficient. The addition of a disc brake system will add to the design challenge by adding weight and packaging difficulties.

The **Task 5** evaluation discusses possible impacts on axle design resulting from a possible need to lighten this safety critical component. As unsprung mass is reduced in high-speed U.S. designs, the bogie axle will become one of the more significant remaining components of unsprung mass. There will be pressure to lighten this component while maintaining reliable and safe operation.

Both European and Japanese axle designs are guided by standard practices defined, in the case of Europe, in conformance with EN 13104, and in Japan according to Japanese Industrial Standard E 4502. North America does not have a standard to govern axle design practice. The study in Task 5 compared U.S. and non-U.S. design practices from the perspective of the three basic areas of axle design standards: (1) input definitions and assumptions, (2) methods of calculating axle stress, and (3) definition of failure criteria. A review and comparison of axle materials was also discussed.

With respect to items 1 and 2, the study showed that the U.S. approach to axle design is more conservative. This is likely due to slower speeds which have allowed heavier axles, and, more importantly for high-speed applications, the lack of sufficient data to permit more accurate characterization of axle loading. Maintaining such conservative practices may result in unacceptably heavy axle designs as speeds increase.

Industry and government cooperation to develop better data and joint design standards should be considered as a way to ensure safe, reliable, and optimized high-speed axle designs.

Another area reviewed in Task 5 was axle material. It was concluded that it may be necessary to consider higher performance materials and improved axle processing techniques to improve fatigue resistance. Further study with industry cooperation is recommended for this area.

In **Task 6**, an assessment was made of the safety risks associated with the three basic drivetrain designs most likely to be applied to 125 mph applications in North America. An FMEA was conducted for each of the design cases to assess the potential for increased risk. It was concluded that locked axle has historically not led to derailment and therefore has not been considered a safety concern. Based on GE's best current knowledge, it was considered unlikely that specific additional safety requirements in the design of the frame-hung traction motor concept would be required. In other words, while there may be additional reliability concerns associated with high-speed designs, they were not felt to be related to an increase in safety risk. However, since safety is the overriding concern in high-speed bogie design, during an actual high-speed bogie design and development program, this area would be investigated much more rigorously than the scope of this study allowed.

Industry standards jointly developed by industry and government for certain of the critical drivetrain components and systems may also be important for ensuring safe optimum designs and possibly reducing costs through standardization.

## 4. References

---

1. ADAMS – User manual
2. Bombardier Bogies: [http://www.bombardier.com/files/en/supporting\\_docs/BT-Bogies-FLEXX\\_Power.pdf](http://www.bombardier.com/files/en/supporting_docs/BT-Bogies-FLEXX_Power.pdf); [http://www.bombardier.com/files/en/supporting\\_docs/BT-Bogies-FLEXX\\_Portfolio.pdf](http://www.bombardier.com/files/en/supporting_docs/BT-Bogies-FLEXX_Portfolio.pdf)
3. CIA World Fact Book <https://www.cia.gov/library/publications/the-world-factbook/geos/gm.html>
4. GE DFSS III tools
5. Gordon J.E., Orringer O., 1995. “Investigation of the Effects of Braking System Configurations on Thermal Input to Commuter Car Wheels.” Volpe National Transportation Systems Center. Report no. DOT/FRA/ORD-95/DOT-VNTSC-FRA-95-7
6. ISO 2631 Evaluation of human exposure to whole-body vibration
7. Kalker, J.J.: Three dimensional Elastic Bodies in Rolling contact, Kluwer Academic Publisher, Dordrecht, 1990
8. MCAT – Department of Transportation, Federal Railroad Administration: 49 CFR Parts 213 and 238 Vehicle-Track Interaction Safety Standards; High-Speed and High Cant Deficiency Operations; Proposed Rule
9. Montgomery, Douglas C. 2005. Design and Analysis of Experiments: Response surface method and designs. New Jersey: John Wiley and Sons, Inc.
10. Siemens Bogie catalog: <http://www.mobility.siemens.com/mobility/global/SiteCollectionDocuments/en/rail-solutions/components-and-systems/bogies-catalog-en.pdf>
11. Siemens Taurus Quill Drive: <http://tams-www.informatik.uni-hamburg.de/applets/jfig/gallery/taurus-antrieb.pdf>
12. Siemens Vectron bogie: [http://www.mobility.siemens.com/mobility/global/en/interurban-mobility/rail-solutions/locomotives/vectron/technology/modular-locomotive-concept/flexible-drive/Pages/flexible-drive.aspx#Vectron the drive system](http://www.mobility.siemens.com/mobility/global/en/interurban-mobility/rail-solutions/locomotives/vectron/technology/modular-locomotive-concept/flexible-drive/Pages/flexible-drive.aspx#Vectron%20the%20drive%20system)
13. Talamini, Jeong, Gordon (2007). Estimation of the Fatigue Life of Railroad Joint Bars, from <http://www.volpe.dot.gov/coi/pis/docs/integrity/jrcice2007-40065.pdf>
14. Technology Vehicle Report issued in August 2011 by the Next Generation Equipment Committee.
15. Trains Magazine [http://trn.trains.com/en/Railroad Reference/Railroad History/2009/09/The Stages of US Railroad Electrification.aspx](http://trn.trains.com/en/Railroad%20Reference/Railroad%20History/2009/09/The%20Stages%20of%20US%20Railroad%20Electrification.aspx)

## Appendix A. Truck Design Fundamentals

---

### A.1 Technical background – high-speed bogie design requirements

This section reviews, in some detail, the basic design requirements required to produce a successful high-speed bogie. The following information provides the technical background to understand in some depth the analyses that follow in Tasks 1–6.

#### Truck Design Requirements and Performance Characteristics

The truck is the interface between the locomotive and the track. As illustrated in Figure A.1.1a below, the interactions between wheel and track geometries provide the dynamic inputs to the truck and locomotive. A complete understanding of the correct and relevant inputs and system responses is a fundamental basic to designing a safe and reliable passenger locomotive truck.

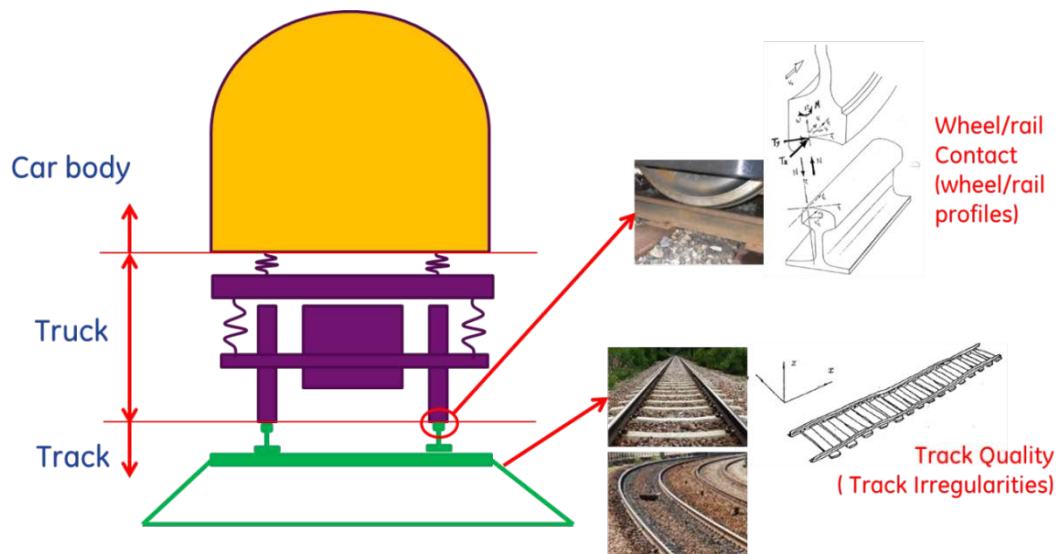

Figure A.1.1a: Wheel-Rail Contact and Track Quality

#### *Truck Functional Requirements*

The truck subsystem provides the following basic functions:

- support the car body weight and distribute the locomotive weight to the axles
- guide and steer the locomotive on the tracks safely and with stability under all operating conditions
- produce traction and braking effort between the wheels and rails
- transmit traction and braking force to the car body
- reduce and isolate vibrations and impact loads from wheel-track interactions
- mount and support auxiliary components and equipment

The basic functional requirements stated above must be met by a system design that will provide an acceptable level of the following six key truck performance measures in a cost effective, reliable, and safe package under the specified operation conditions:

- 1) Running stability
- 2) Derailment safety
- 3) Wheel-rail dynamic forces
- 4) Braking capability
- 5) Ride quality and passenger comfort
- 6) Component and structural reliability and life

Each of these important truck characteristics is described in more detail in the following sections.

#### A.1.1.1 Running stability

The locomotive truck must be designed to be dynamically stable under all specified track and operating conditions. Theoretically, “stable” means that none of the Eigen values of the locomotive dynamics system would have a “positive” real part. In practice, stability is achieved by limiting the vibration of the locomotive system to a set of specified acceleration values that will ensure the system does not go into hunting mode.

Wheel and rail rolling contact is a unique mechanical element in the locomotive-track interaction system. The characteristics of its creepage-force (relative speed-force) relations are essential for the running stability of the locomotive truck. As shown below in Figure A.1.1-b, the forces developed between the wheel and the rail, in the contact patch, are determined by the following relationships:

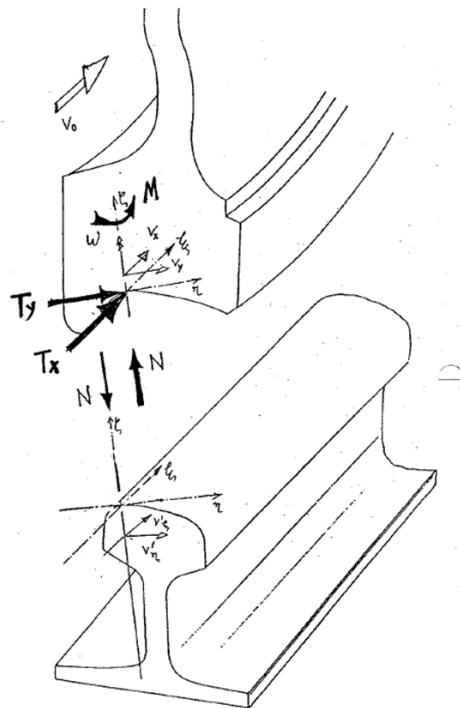

Figure A.1.1b: Wheel-rail rolling contact



$$\begin{cases} T_\xi \\ T_\eta \\ M \end{cases} = \begin{cases} f_\xi(v_\xi, v_\eta, \omega) \\ f_\eta(v_\xi, v_\eta, \omega) \\ f_\zeta(v_\xi, v_\eta, \omega) \end{cases}$$

where:

$T_\xi$  – Longitudinal tangential creep force,

$T_\eta$  – Lateral tangential creep force,

$M$  – Moment around the normal of the contact patch,

$f_\xi(v_\xi, v_\eta, \omega)$  – function of longitudinal tangential creep force; determined by the contact geometry between the wheel and the rail as well as by the normal contact force,

$f_\eta(v_\xi, v_\eta, \omega)$  – function of lateral tangential creep force; determined by the contact geometry between the wheel and the rail as well as by the normal contact force,

$f_\zeta(v_\xi, v_\eta, \omega)$  – function of moment around the normal of the contact patch; determined by the contact geometry between the wheel and the rail as well as by the normal contact force,

$v_\xi$  – Longitudinal creepage,  $v_\xi = \frac{V_{\xi_w} - V_{\xi_r}}{V}$ ,

$v_\eta$  – Lateral creepage,  $v_\eta = \frac{V_{\eta_w} - V_{\eta_r}}{V}$ ,

$\omega$  – Spin creepage,  $= \frac{\omega_w - \omega_r}{V}$ ,

$V_{\xi_w}, V_{\eta_w}, \omega_w$  – Longitudinal, lateral, and spin speeds of the wheel in the coordinate system  $(\xi, \eta, \zeta)$  at the contact patch (see Figure A.1.1b),

$V_{\xi_r}, V_{\eta_r}, \omega_r$  – Longitudinal, lateral, and spin speeds of the rail in the coordinate system  $(\xi, \eta, \zeta)$  at the contact patch (see Figure A.1.1b),

$V$  – Locomotive running speed

The total tangential force at the contact patch can be determined by:

$$T = \sqrt{T_\xi^2 + T_\eta^2}$$

The creep forces  $T_\xi$ ,  $T_\eta$  and  $M$  are nonlinear functions of the wheel and locomotive speeds, as illustrated in Figure A.1.1c. For a given locomotive speed, the creep forces increase when the creepages (relative speed between wheel and rail) increase. But once the creepages reach a large value, the creep forces will decrease with further increase of the creepages, and this introduces a negative damping in the wheel-rail contact. On the other hand, if the locomotive speed increases, the slope of the creep-force creepage curve will become smaller. This means that the damping in the wheel-rail contact will decrease as the locomotive speed increases.

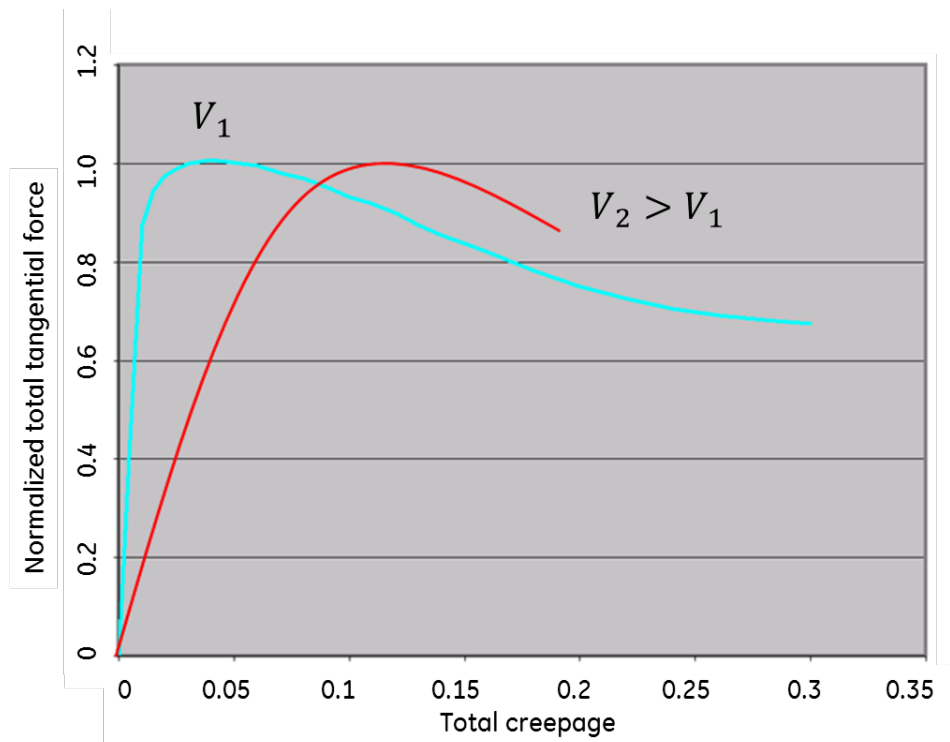

**Figure A.1.1c: Normalized total tangential force of  $\frac{T}{\mu N} = \sqrt{T_{\xi}^2 + T_{\eta}^2} / \mu N$  as a function of the total tangential creepage**

The creep forces in the contact patch are saturated when the entire contact patch becomes a “sliding” area due to large creepages. The relation between the three creep forces  $T_{\xi}$ ,  $T_{\eta}$  and  $M$  is described by a “saturation surface,” as shown in Figure A.1.1d. Due to extreme creepage in any of the three directions—longitudinal, lateral or spin—the creep force can be saturated in that direction. For example, if lateral or spin creepage is too large in the contact patch, there will not be much tractive effort produced in longitudinal direction.

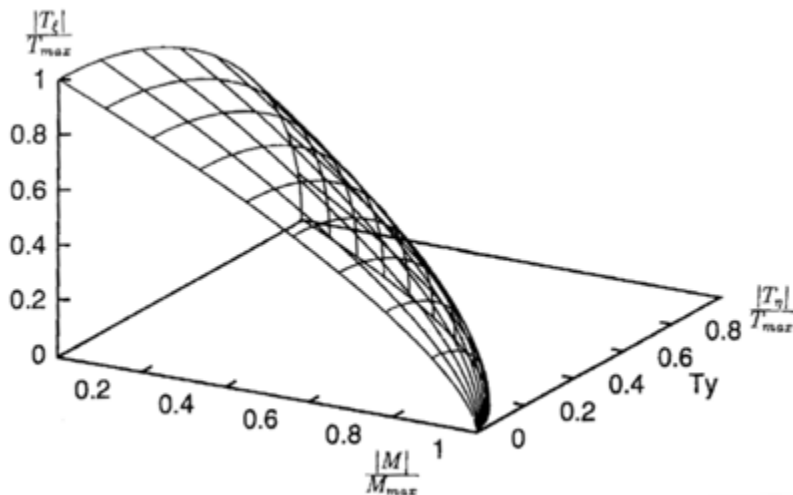

**Figure A.1.1d: Saturation surface of creep forces**

The fact that the wheel-rail contact forces are locomotive speed dependent and the damping in the contact patch decreases with the increase of locomotive speed can lead to an unstable phenomenon known as hunting.

The speed at which the wheelset becomes unstable is the “wheelset hunting speed,” also called “critical speed.” Hunting begins when the critical speed for a specific wheel-rail profile combination is reached. At speeds below the critical speed ( $V_c$ ), the lateral and yaw motions (Figure A.1.1-e) of the wheelset are damped down when a track induced disturbance occurs (Figure A.1.1- f (a)) due to sufficient damping in the system. At speeds above the critical speed, any disturbance on the track can cause the wheelset motions to grow (Figure A.1.1-f(c)) due to lack of damping in the system. The unstable motions will grow until wheel flange contact occurs to create a forced limit cycle motion.

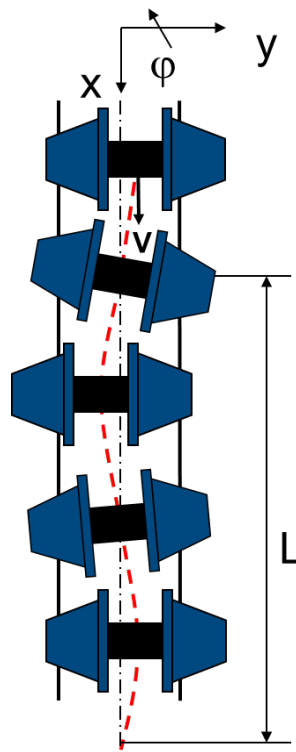

**Figure A.1.1-e: Hunting motion of a wheelset:  $y$ - lateral displacement,  $\phi$ - yaw angle**

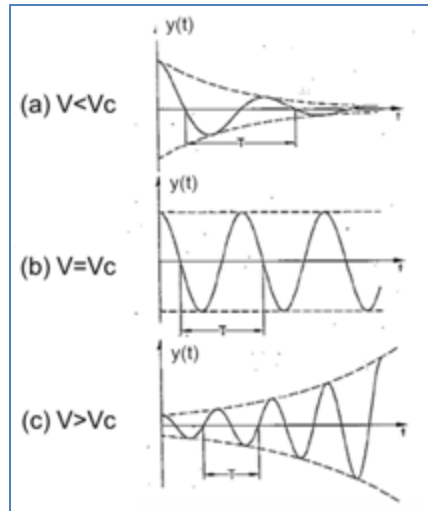

**Figure A.1.1-f: Lateral displacement of wheelset on ideal straight track**

In addition to the wheelset hunting mode described above, there are two other hunting modes for a locomotive with primary and secondary suspension systems. The three basic hunting modes are listed below:

- Wheelset hunting – combination of lateral and yaw motions of the wheelset
- Truck hunting – combination of lateral and yaw motions of the truck frame
- Car body hunting – combination of lateral and yaw motions of the car body

Any of these unstable modes can cause severe vibration and conditions that can lead to derailment. Selection of the proper suspension mechanisms and parameters is vital to ensure that the critical speeds for all the unstable hunting modes will be well above the maximum locomotive operating speeds for all new and worn locomotive and track conditions.

Design strategies which generally improve locomotive running stability and increase critical speed include: (1) increasing axle guiding stiffness in lateral and yaw direction, (2) higher lateral and yaw stiffness in secondary suspension, and (3) longer wheelbase and proper selection of the distance between the two trucks.

### **A.1.1.2 Derailment Safety**

It is an obvious fundamental requirement that the locomotive must run safely on both straight and curved tracks at all operating speeds and all track and equipment conditions. The optimum configuration for the most stable operation on straight track may be at odds with the best configuration for operation on curved track. As with many areas of truck design, it is necessary to understand and manage the tradeoffs to create a design that will meet the safety requirements for all conditions.

Derailment potential is measured by wheel and axle derailment coefficients as well as wheel load reduction:

- Wheel derailment coefficient  $\frac{L}{V}$ , where L is the lateral force acting on the wheel, and V is the vertical force, as shown in Figure A.1.1g below

- Axle sum  $\frac{L}{V}|_{axle}$ , where:
 
$$\frac{L}{V}|_{axle} = \left| \frac{L}{V}|_{left\ wheel} \right| + \left| \frac{L}{V}|_{right\ wheel} \right|$$
- Wheel load reduction  $\frac{dV}{V_0}$ , where  $V_0$  is the static wheel load and  $dV = V - V_0$

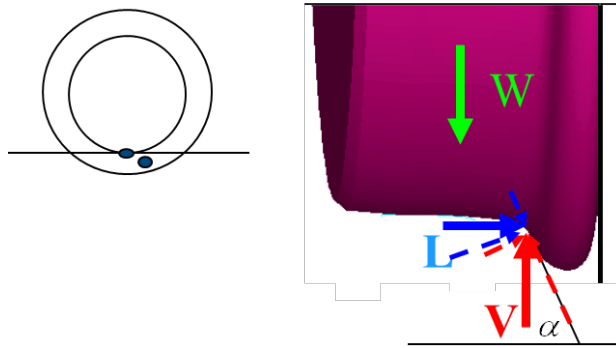

**Figure A.1.1g: Lateral and vertical forces acting on the wheel**

Wheel and axle derailment coefficients and wheel load reduction must be within specified limits to ensure derailment does not occur.

### ***Curve Negotiation***

Derailment safety is of special significance on curved track. Curved track is typically super-elevated in order to provide better force balance while negotiating the curve (see Figure A.1.1-h). During a curve, the wheel on the high rail (outside rail of the curve) has to travel more distance than the wheel on the inner rail in order for the wheels to purely roll (no slip) on the rails. This travel distance can be achieved by providing tapered wheel surfaces (conicity), which provide a rolling radius difference between the outer and inner wheels, as shown in Figure A.1.1-i below.

For negotiating curves with large radius, the difference of travelling distances between the outer and inner rails is small. The conicity of the wheel profiles can provide sufficient rolling radius difference between the outer and inner wheels to meet the necessary requirement for pure rolling. But for curves with small radius, the rolling radius difference between the wheels will be limited by the wheel profile design. The radius difference will not be large enough to allow pure rolling. This leads to a difference between the angle of the wheelset axle and the radial direction of the curve called the attack angle (see Figure A.1.1-j below). The existence of the attack angle can cause wheel slip and result in a “forced negotiation.” A large attack angle increases the L/V ratio and therefore the risk of derailment.

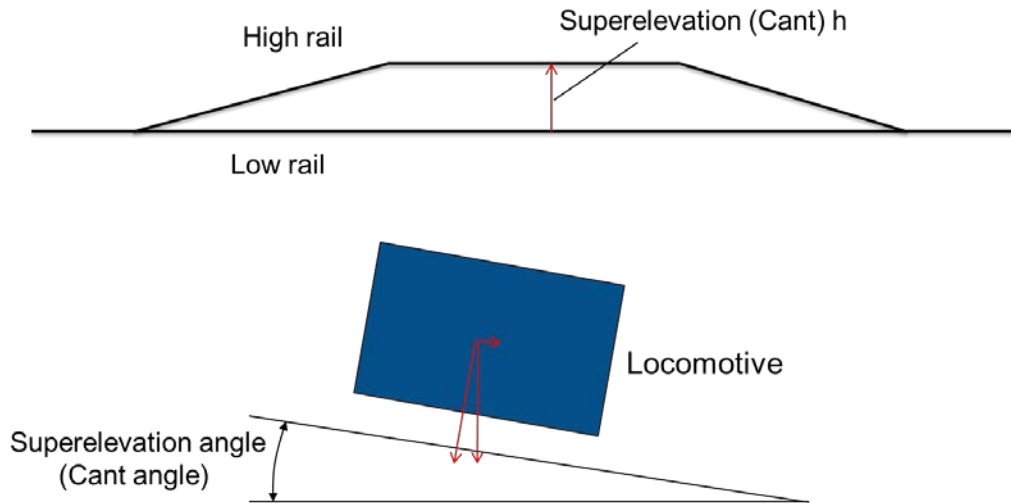

**Figure A.1.1-h: Configuration of curved track—superelevation provides centric force to help curve negotiation**

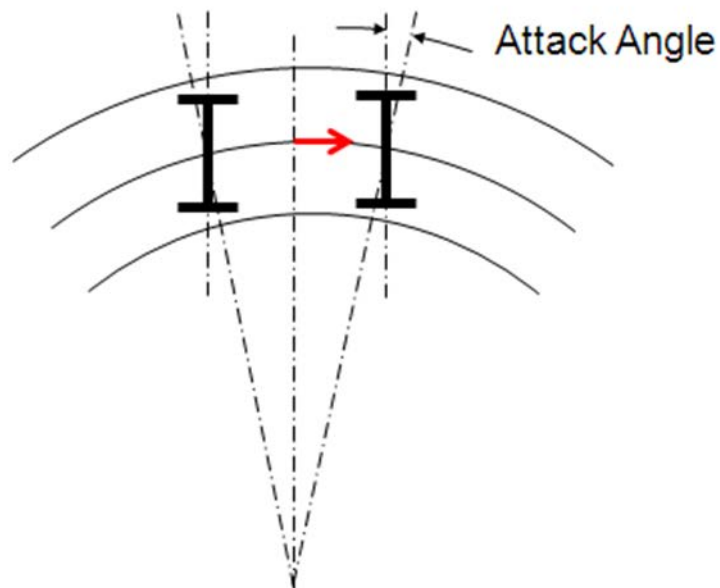

**Figure A.1.1-i: Attack angle during curve for a 2 axle truck**

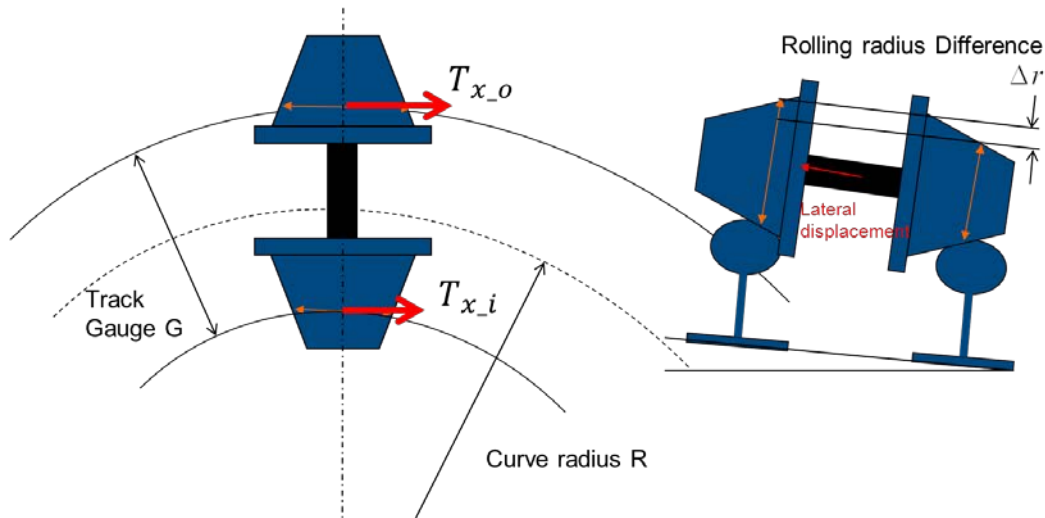

**Figure A.1.1-j: Pure rolling and self-steering**

When the wheelset negotiates a curve, the longitudinal creepage at the outer wheel (on the high rail) is larger than that at the inner wheel, due to its larger rolling radius. Therefore, the longitudinal creep force on the outer wheel will be larger than that on the inner wheel, as shown in Figure A.1.1-j above. The resultant moment due to this force difference will help the wheelset try to position itself in a more radial orientation. The capability of the wheelset to purely roll (as stated in the above section) and position itself in radial orientation due to its rolling radius difference is known as “self-steering.” Depending on the curve radius, especially for sharp curves, this self-steering capability of the wheelset with tapered wheel profiles may not be good enough for the wheelset to steer through the curve completely in the radial direction.

### ***Radial Steering***

For best curving performance, each of the truck wheelsets should be aligned in the radial direction, as shown above in Figure A.1.1-k below. The truck design, especially the design of the axle guiding devices, should provide enough compliance for the wheelset to steer when it enters a curve. The secondary suspension should be designed in such a way that it will allow the truck to rotate smoothly when the locomotive enters a curve and also provide enough restoring stiffness for the truck to rotate back to its normal position when it leaves the curve. Shorter wheelbase and softer primary and secondary yaw stiffness will help to improve curving stability.

Wear on both wheel and track is generally higher on curved track. In addition to increasing maintenance costs, this can also lead to poor performance and stability. Reducing attack angle and avoiding flange and multipoint contact by properly selecting the suspension parameters will help to slow wheel-rail wear.

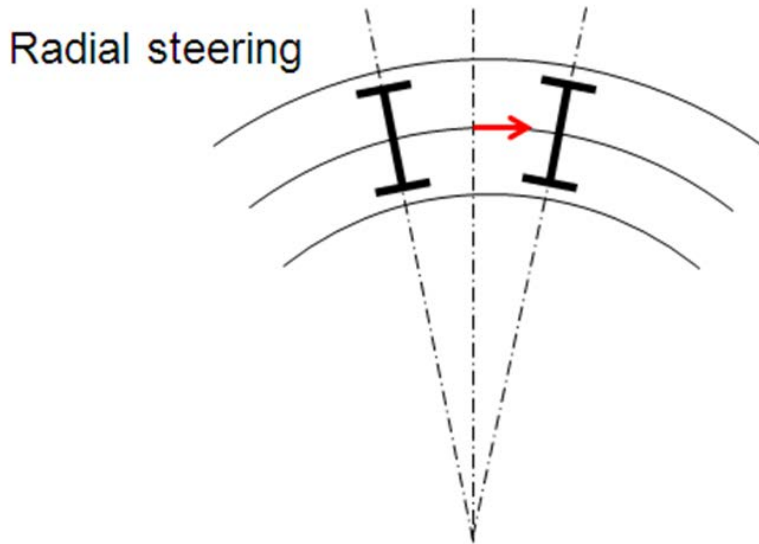

**Figure A.1.1-k: Radial steering of 2 axle truck**

As shown, there is a conflict between running stability and curving performance in suspension system design. A tradeoff analysis must be properly conducted so that both performance modes can meet the safety requirements.

### A.1.1.3 P2 and other wheel-rail dynamic forces

Extreme dynamic forces exerted by the wheels on the rails may damage both the track and locomotive components, as well as increase wear. The following performance index/variables are used to evaluate the wheel-rail dynamic forces:

- Lateral wheel force,  $L$
- Track shift force (lateral axle force),  $\sum L_{axle}$
- Truck side,  $L/V$

$$\frac{L}{V} |_{truck\ side} = \frac{\sum L_{truck\ side}}{\sum V_{truck\ side}}$$

- P2 force – a vertical force of wheel on rail, determined as

$$P_2 = P_0 + 2\alpha V \left( \frac{M_u}{M_u + M_t} \right)^{1/2} \left( 1 - \frac{\pi C_t}{4[K_t(M_u + M_t)]^{1/2}} \right) (K_t M_u)^{1/2}$$

Where (see Figure A.1.1-1 below)

$P_0$  – Static wheel load (N)

$2\alpha$  – Total angle of vertical ramp discontinuity (rad)

$V$  – Locomotive speed (km/h)

$M_u$  – Unsprung mass (kg/wheel)



$M_t$ – Effective track/rail mass per wheel (kg)  
 $K_t$  – Effective track/rail stiffness per wheel (N/m)  
 $C_t$ – Effective track/rail damping per wheel (Ns/m)

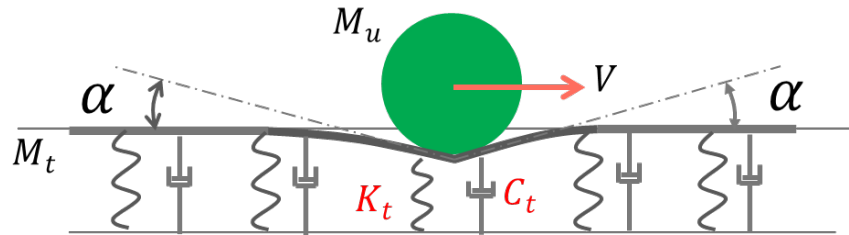

**Figure A.1.11: P2 force**

The lateral wheel-rail contact forces, which include lateral wheel force, track shift force, and truck side L/V, heavily depend on the locomotive stability and curving performance. As indicated previously, proper design of the axle guiding mechanism and selection of primary and secondary suspension parameters, as well as the wheel base and loco length, will help improve the lateral wheel-rail forces.

P2 force is a measure of the total vertical force of a wheel acting on the rail when the wheel runs through a ramp, or dip angle, on the rail. It includes the static wheel load and the dynamic force due to the unsprung mass. The amplitude of the P2 force is determined by both the track characteristics (track mass, stiffness, damping, and discontinuity angle) and the locomotive characteristics (unsprung mass and wheel load), as well as the operating condition (locomotive speed). From a truck design perspective, the P2 force will be primarily determined by the locomotive wheel load (locomotive weight) and the unsprung mass, for a given track infrastructure and locomotive speed. The smaller the wheel load and unsprung mass are, the lower the P2 force would be.

The unsprung mass, also called dead weight, includes the weight of the wheelset and the weight of components mounted on the axle. Any design which reduces the weight of the wheel and axle, and any reductions to the weight of components mounted on the axle and wheel, will reduce the unsprung mass and therefore reduce the P2 force. Frame or body hung motors, and semi- or fully suspended drivetrains, are the most common methods to significantly reduce the unsprung mass.

#### **A.1.1.4 Braking capability**

Brake capability is essential for high-speed locomotive. The brake system design should meet the specified stopping distance or deceleration requirement for the specified locomotive speed range and braking frequency. Depending on the customer specification, the brake performance can be achieved by air brake only, blended brake (DB + air brake), or a combination of air brake and other brake types, such as eddy current brake or aero DB. However, “air brake only” is the common minimum requirement for emergency brake, due to safety regulations.

High-speed passenger locomotives have a more demanding braking application than slower freight locomotives, in terms of energy that must be dissipated by the brake system. The

traditional tread brakes alone, which are normally used for low-speed application and are limited by the capacity of the locomotive wheels to absorb heat without exceeding transformation temperature and damaging the wheel and brakes, will no longer be capable of meeting the high-speed locomotive application standards. Therefore, disc brakes are commonly used for higher speed application because of their higher energy absorption capability and the lack of wheel damage. But, disc brakes also have a limit on the amount of energy that can be absorbed. To meet the braking requirement, proper numbers of discs must be determined.

Disc brakes can be wheel mounted discs, axle mounted discs, or separate axle mounted discs. As indicated, adding discs either on the wheel or on the axle will increase the unsprung mass, and therefore the P2 forces. This adds significantly to the challenge of designing a high-speed diesel locomotive which is already very heavy because of its engine and its support equipment. In addition, adding a disc brake system to a location on the truck other than the wheel and axle will take up space in the already crowded bogie system.

#### **A.1.1.5 Ride quality or comfort**

In addition to controlling and reducing the vibrations on the locomotive introduced by track irregularities which may cause damage to locomotive components, a suitable working environment for the crew in the operator cab should be created by proper design of the locomotive suspension system. This working environment will be defined and evaluated as ride quality or comfort.

There are different standards for ride quality or comfort. Ride index according to Sperling (see References) is a popularly used evaluation method because of its simplicity. ISO 2631 is an internationally recognized standard for evaluation of human exposure to whole-body vibration. Depending on the standards, either accelerations or velocities measured in the operator cab or on the operator seat will be used for the ride quality or comfort evaluation. Therefore, reducing the vibrations (lateral, vertical, and longitudinal accelerations or velocities) in the operator cab and operator seat by proper design of the primary and secondary suspension systems will help improve the ride quality and operator comfort. Once again, design tradeoffs will have to be thoroughly understood and optimized, as characteristics that provide the most comfortable ride may not be the most desirable for stability.

#### **A.1.1.6 Life and reliability**

As indicated in the previous sections, the truck, while operating in an environment with extreme dynamic loading, will support the locomotive car-body weight, guide the locomotive on the straight track and negotiate curved track, generate and transmit tractive and braking efforts, as well as reduce and isolate vibrations. All of the truck components have to withstand not only the static loads, but also the dynamic alternating loads. The design of the components must meet both proof and fatigue strength requirements with sufficient safety margin for the specified design life. Clear understanding and prediction of the loads and duty cycles under specified U.S. track and operation conditions, proper application of suitable design methods, as well as proper selection and application of materials and manufacturing technologies will help increase the component/structure reliability for safe operation of the high-speed truck.

#### ***Bogie Design Tradeoffs***

The six key performance traits described above must all be designed to meet the specifications required to ensure safe reliable operation of a high-speed passenger truck. Though already

noted, it is worth repeating that the best design to meet each performance trait may conflict with the optimal designs for other traits. Examples include designing for stability in straight versus curved track, P2 force versus unsprung mass increases due to additional brake systems, and meeting component life and reliability requirements versus the need to reduce weight, and many others. Providing a final optimized design that meets all the performance requirements will require detailed and complex tradeoff analyses. This is particularly true in the case of the high-speed truck design that will be required to meet the new PRIIA specifications. The need to reduce P2 forces significantly below the current levels, while dealing with weight increases resulting from crashworthiness and T4 emissions requirements, will add difficulties to a design that was already challenging.

## Appendix B.

### Survey results tables—Truck design parameters

<b>Truck type (axle arrangement)</b>	SF1 (Bo-Bo) for E-loco	SF2 (Bo-Bo) for E-loco	SF3 (Bo-Bo) for E-loco	SF4 (F4)
<b>Builder</b>	Siemens	Siemens	Siemens	Siemens
<b>Speed range</b>	230km/h (357 kph)	140 km/h	160 km/h	200 km/h
<b>Axle load</b>	21.5t	22t	22t	80~90/4=20~22.5t
<b>Motor Suspension design</b>	Frame-hung	Axle-hung	Semi frame-hung	Frame-hung
<b>Drivetrain design</b>	Quill	Gear box	Gear box	Hollow shaft drive (option: fully suspended quill drive)
<b>Brake design and arrangement</b>	2 discs on separate shaft	Wheel disc brake	Wheel brake discs	Wheel discs
<b>Parking brake design and arrangement</b>	Spring loaded brake	Spring loaded system	Spring loaded brake	Spring loaded brake
<b>Axle design</b>			Forged Hollow axle	Hollow-bored axle shaft
<b>Wheel diameter (new and worn)</b>	1150/1070 mm	1250/1170 mm	1100/1020 mm	1250/1170 mm
<b>Wheelbase</b>	3000 mm	2900 mm	2700 mm	2900 mm (3000 mm)
<b>Max TE/Axle</b>	300KN/4	300KN/4	62.5KN	300KN/4=75KN
<b>Power per axle</b>	1.6 MW/4	1.6 MW/4	750 KW	
<b>Bogie frame design</b>	Fabricated	Fabricated	Fabricated	Fabricated
<b>Primary suspension (vertical)</b>	2 coil springs per JB, 1 vertical damper per JB	2 coil springs per JB, 1 vertical damper per JB	2 coil springs per JB, 1 vertical damper per JB	coil springs
<b>Axle guiding design</b>	3 points, bushings (vertical arrangement)	3 points, bushings (vertical arrangement)	3 points, bushings (vertical)	Bushings (vertical arrangement)
<b>Secondary suspension</b>	2 coil springs per side (lateral arrangement), vertical and yaw dampers	2 coil springs per side (lateral arrangement), vertical, yaw dampers	2 coil springs per side (lateral arrangement), lateral & vertical and yaw dampers	Flexcoil spring with low rotational stiffness
<b>Traction link design between truck and car body</b>	Pivot	Pivot / sliding plates	Pivot / sliding plates	Pivot
<b>Gauge</b>	1435 mm	1435 mm	1435 mm	1435 mm
<b>Minimum curve</b>	120 m	80 m	120/100 m	90 m (E)/100 m (D)
<b>Bogie weight</b>	18t	17t	14t	
<b>Application</b>	Taurus at Austria Federal Railway (OBB); OBB / Austria DB AG / Germany MAV / Hungary GYSEV / Hungary Dispolok / Europe RTS / Austria SZ / Slovenia SNCB / Belgium	DB AG / Germany Dispolok / Europe SBB / Switzerland Mitsui / Europe CP / Portugal	OBB / Austria KCRC Hong Kong / China Dispolok / Europe Several European operators	Vectron (European application) 2010; Belgium State Railways (SNCB) Northeast Corridor / Keystone corridor – ACS-64

<b>Truck type (axle arrangement)</b>	Flex 120 (Co-Co)	Flex Power 140/200 (Bo-Bo)	Flex Power 250 (Bo-Bo)	Flex Power 350 (Bo-Bo)
<b>Builder</b>	Bombardier	Bombardier	Bombardier	Bombardier
<b>Speed range</b>	80–120 km/h	140/200km/h	250km/h	330km/h
<b>Axle load</b>	22–30t	22t	21t (APL 45-32.66t)	17t
<b>Motor suspension design</b>	Axle-hung	Flexx 140:Axle-hung, Flexx 200: Frame-hung (Fully suspended drive)	Car body, Bogie frame-hung (Fully suspended drive)	Hung motor (Axle-hung gearbox; motor fully suspended in bogie frame = partly
<b>Drivetrain design</b>				
<b>Brake design and arrangement</b>	Double side tread brakes	Wheel disc brakes	Hollow shaft mounted axle disc brakes	Mounted disc brakes and 2 axle mounted disc
<b>Parking brake design and arrangement</b>				
<b>Axle design</b>				
<b>Wheel diameter (new and worn)</b>	1067mm	1250mm	1118 (44")/1046 (41.2")(APL45-44")	1040mm
<b>Wheelbase</b>	2 x 1850mm	2600mm	2650mm	2650mm
<b>Max TE/Axle</b>	259-350KN/3	160KN/2	150KN/2	100/2 KN
<b>Power per axle</b>				
<b>Bogie frame design</b>	Fabricated, flat	Fabricated, flat	Fabricated	Fabricated, center low
<b>Primary suspension (vertical)</b>	2 coil springs per JB	2 coil springs per JB, 1 vertical damper per JB	2 coil springs per JB, 1 vertical damper per JB	2 coil springs per JB, 1 vertical damper per JB
<b>Axle guiding design</b>	Bushing (lateral arrangement), end axle	2 point links, bushing in lateral	2 point links, bushing in lateral	2 point link, bushing in lateral
<b>Secondary suspension</b>	2 coil springs per side (longitudinal arrangement), 1 vertical damper per side, 2 lateral dampers	(longitudinal arrangement), 1 vertical damper per side, (2 lateral dampers), 1 yaw damper per side	(longitudinal arrangement), 1 vertical damper per side, (2 lateral dampers), 1 yaw damper per side	(longitudinal arrangement), 1 vertical damper per side, (2 lateral dampers), 2 yaw damper per side
<b>Traction link design between truck and car body</b>	Traction rod	Traction rod at the end transom (low traction point)	Traction rod at the end transom	(center traction rod)
<b>Gauge</b>	1000 / 1067 / 1435mm	1435	1435	1435mm
<b>Minimum curve</b>				
<b>Bogie weight</b>	23.8t	16t	16t	11.7t
<b>Application</b>	Blue Tiger locomotives; IORE locomotives	TRAXX locomotives, D B A G, SBB, BLS, SNCB, Angel Trains, Mitsui and others	North American ALP 46 locomotives *260); ALP 45 DP	AVE**S-102

<b>Truck type (axle arrangement)</b>	Prima II locomotive (Bo-Bo)	DF11G (Co-Co)	Maxima (Co-C0)
<b>Builder</b>	Alstom	China	Voith
<b>Speed range</b>	200 km/h (Freight 140kph)	170km/h	120~160km/h
<b>Axle load</b>	22t (21.5~22.5t)	23t	126~135/6t (30 C C/40C C)
<b>Motor suspension design</b>	Frame-hung (gear box on axle)	Frame-hung, Quill	
<b>Drivetrain design</b>		Quill	Hydrodynamic
<b>Brake design and arrangement</b>	Wheel disc brakes		Electro-pneumatic and Hydrodynamic
<b>Parking brake design and arrangement</b>			
<b>Axle design</b>			
<b>Wheel diameter (new and worn)</b>	1160mm (1150 freight)	1050	
<b>Wheelbase</b>	3000mm (2600 freight)	2*2000	
<b>Max TE/Axle</b>	320/4 KN	245/6 KN	519/6 KN
<b>Power per axle</b>			
<b>Bogie Frame Design</b>	Fabricated		
<b>Primary suspension(vertical)</b>	2 coils/JB, 1 vertical damper/JB	Coil spring	
<b>Axle guiding design</b>	Diagonally arranged traction links / JN (bushings)	"Z" link	
<b>Secondary suspension</b>	2 coils in side (longitudinal arrangement)	Coil spring	
<b>Traction link design between truck and car body</b>	Traction rods at both ends	4-roads parallel	
<b>Gauge</b>	1435mm	1435	
<b>Minimum curve</b>		145m	80m
<b>Bogie weight</b>	18.6t (16.95t freight)		
<b>Application</b>	Prima II		Germany, Poland, Benelux and others

<b>Truck type (axle arrangement)</b>	Vossloh Wuro 3000 AC (Euro Light) Bo-Bo	Vossloh Euro 4000 AC (Co-Co)	PL 42 AC (Bo-Bo)	Bo-Bo
<b>Builder</b>	Vossloh	Bossloh	Bossloh, EMD, Alstom	Talgo
<b>Speed range</b>	Up to 200km/h	160km/h	160km/h	200km/h
<b>Axle load</b>	88/4	21t	130/4t	17?
<b>Motor suspension design</b>	Axle-hung (Nose suspension)	Nose suspension	Frame-hung	
<b>Drivetrain design</b>				Universal shaft Cardan shaft)
<b>Brake design and arrangement</b>	Wheel discs	Disk/wheel	Wheel discs	Wheel discs
<b>Parking brake design and arrangement</b>				
<b>Axle design</b>		Hollow		
<b>Wheel diameter (new and worn)</b>	1117mm	1067		1010
<b>Wheelbase</b>	2600mm			2800mm
<b>Max TE/Axle</b>	305/4		311KN/4	
<b>Power per axle</b>				
<b>Bogie frame design</b>	Fabricated	Fabricated	Fabricated	Fabricated
<b>Primary suspension (vertical)</b>	2 coil springs + JB, vertical dampers			
<b>Axle guiding design</b>	Link			
<b>Secondary suspension</b>	2 coils /side (longitudinal), vertical / lateral dampers, Anti-roll bar			
<b>Traction link design between truck and car body</b>	Center pin (pivot)	Rubber-metal		
<b>Gauge</b>	1435mm	1435		
<b>Minimum curve</b>				
<b>Bogie weight</b>				
<b>Application</b>				

<b>Truck type (axle arrangement)</b>	Genesis: Bo-Bo	MBTA Bo-Bo	Ansaldo Bo-Bo
<b>Builder</b>	GE/Vossloh	GE/MPI	Amsaldo Breda
<b>Speed range</b>	117km/h (110mph)	165.8km/h (103mph)	220kph
<b>Axle load</b>	30.38t (67000lbs)	33t (72750lbs)	22t
<b>Motor suspension design</b>	Axle-hung	Axle-hung	Frame-hung
<b>Drivetrain design</b>	Gear	Gear	Quill
<b>Brake design and arrangement</b>	Tread	Tread	Wheel discs
<b>Parking brake design and arrangement</b>			
<b>Axle design</b>			
<b>Wheel diameter (new and worn)</b>	1016 (40")	1016 (40")	1100 (43.3") and 40.94"
<b>Wheelbase</b>	2750	2845mm (112")	2750
<b>Max TE/Axle</b>			315KN/4
<b>Power per axle</b>			1500KW (2000HP)
<b>Bogie frame design</b>	Fabricated	Cast	Fabricated
<b>Primary suspension (vertical)</b>	2 coil springs + Journal box	Coil springs	Coil springs (on top of JB)
<b>Axle guiding design</b>	3 points link, vertical bushings	Pedestal leg	Integrated rotational arm (JB and link integrated into one part)
<b>Secondary suspension</b>	Rubber + coil springs (in series), 2 sets per side (longitudinal arrangement)	Coil spring	Coil springs (2/side, longitudinal)
<b>Traction link design between truck and car body</b>	Center pin		Traction rod
<b>Gauge</b>			1435
<b>Minimum curve</b>			90m (yard), 149m (line), max cand deficiency 6"
<b>Bogie weight</b>		15.37t (3900 lbs)	
<b>Application</b>			E403 for Trenitalia



## Appendix C. Basic configurations of surveyed trucks

---

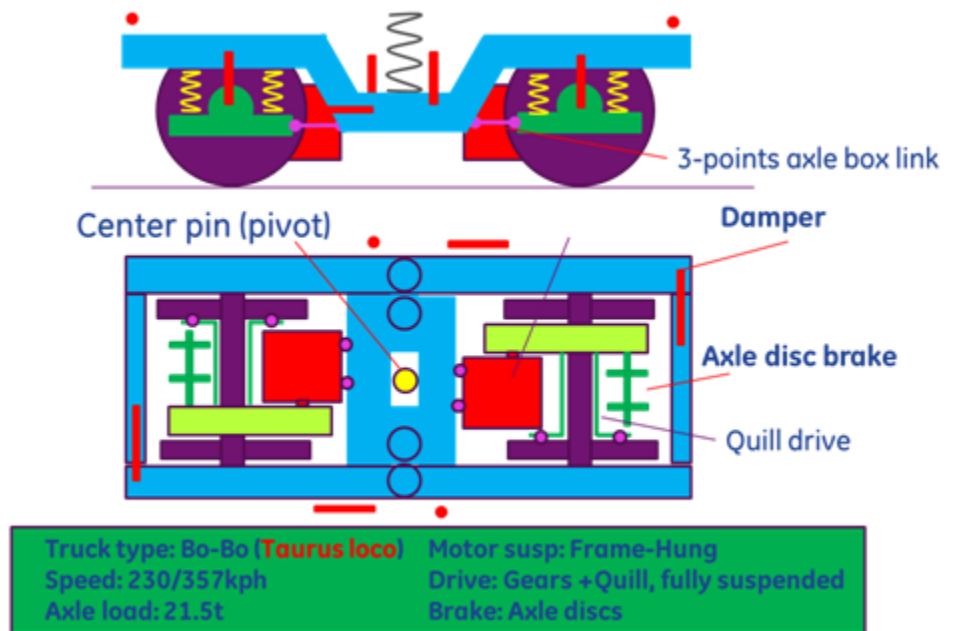

Figure C.1a: Siemens SF1 High-Speed Truck with Frame-Hung Motor

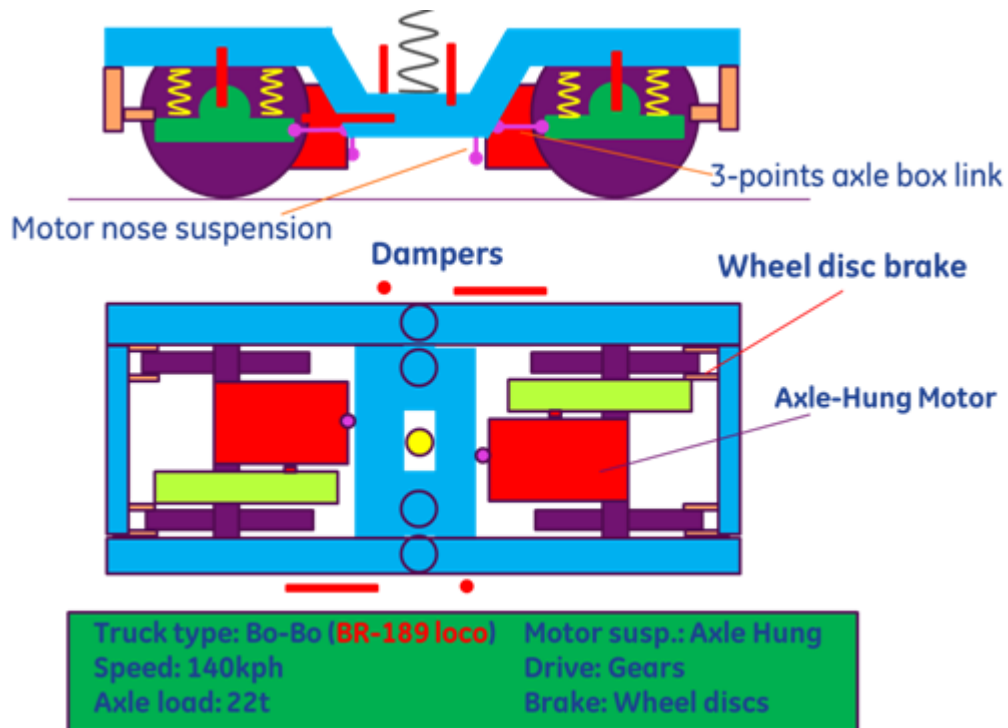

Figure C.1b: Siemens SF2 Truck with Axle-Hung Motor

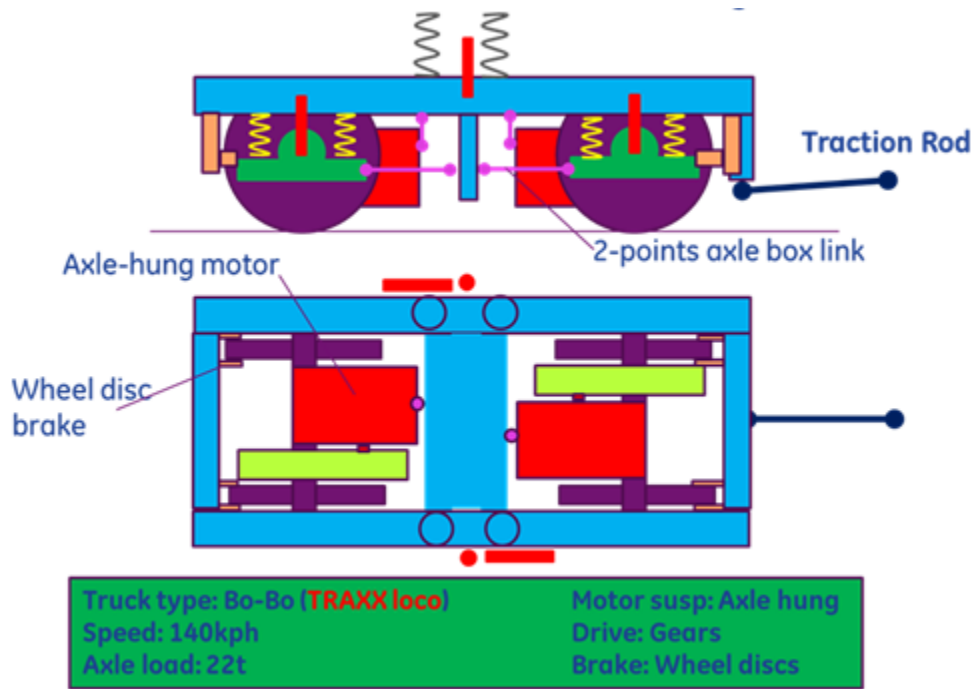

Figure C.1c: Bombardier Flexx 140 Truck with Frame-Hung Motor

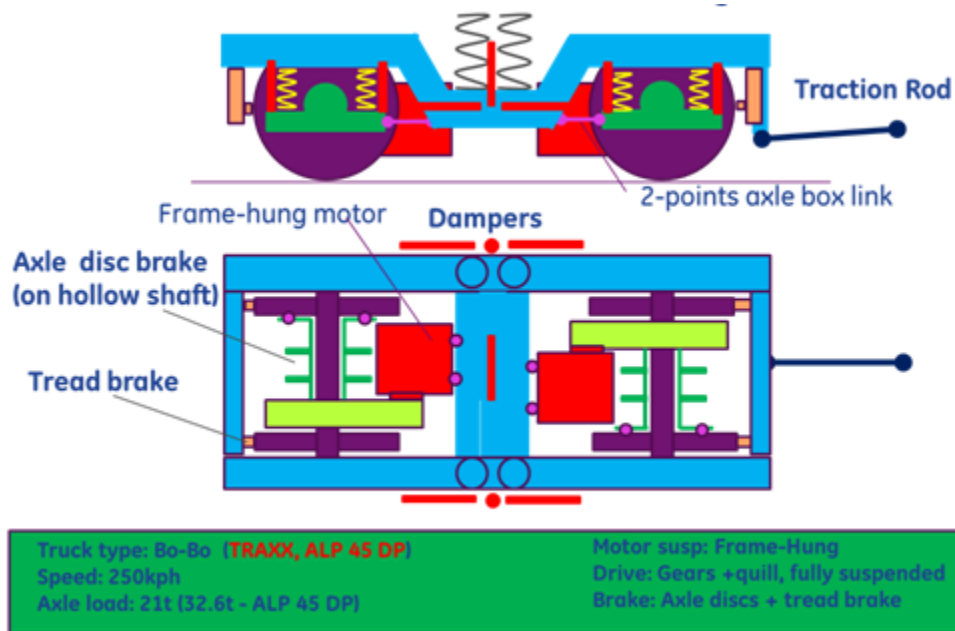

Figure C.1d: Bombardier Flexx 250 Truck with Frame-Hung Motor

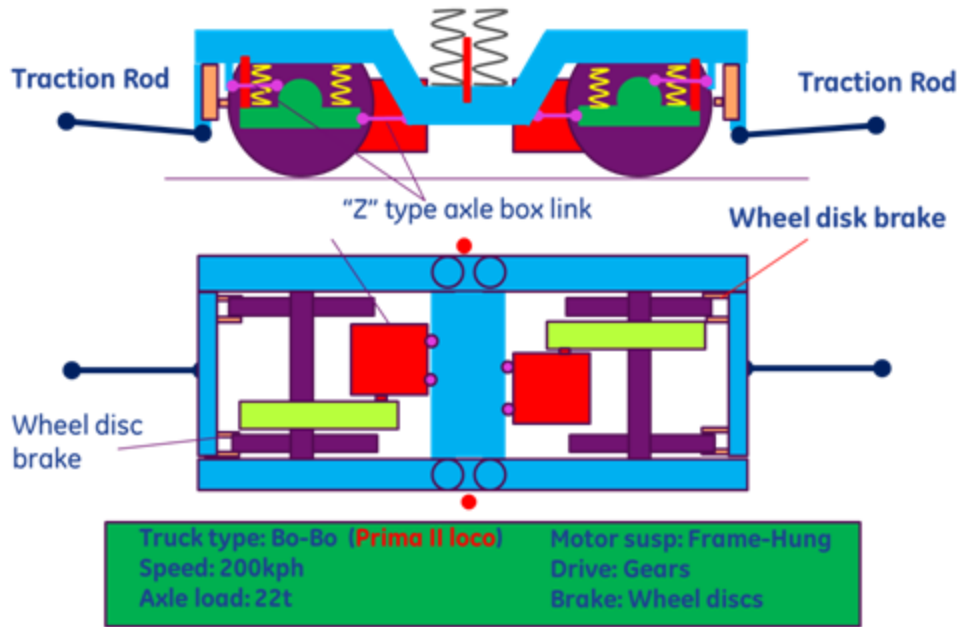

Figure C.1e: Alstom Truck with Frame-Hung Motor and Double Traction Rods

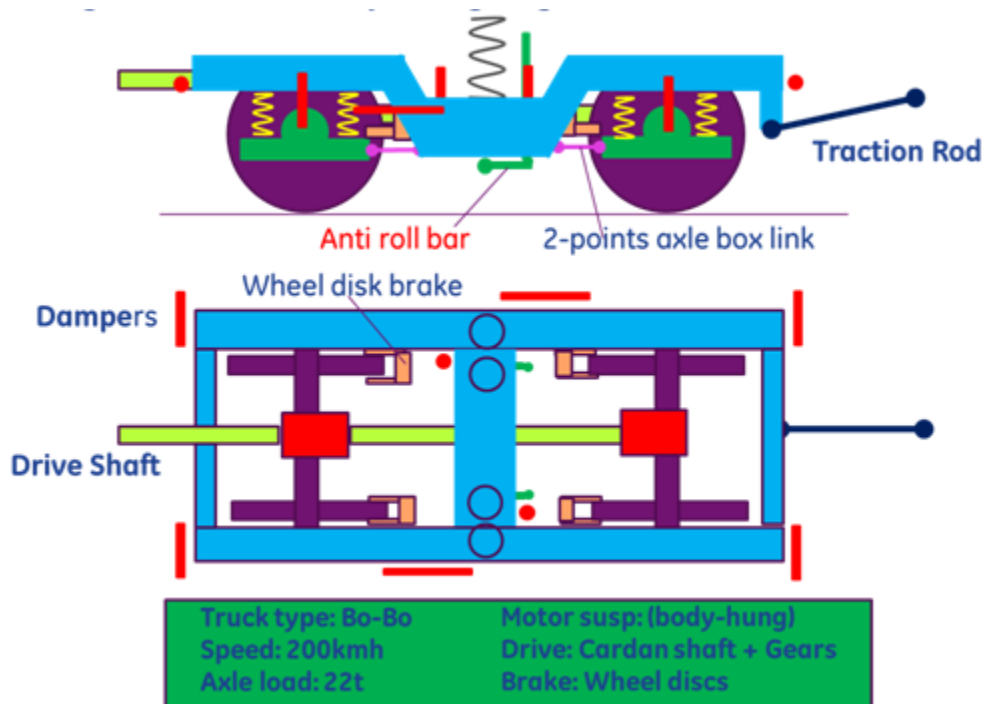

Figure C.1f: Talgo Truck with Body-Hung Engine and Cardan Shaft Drive

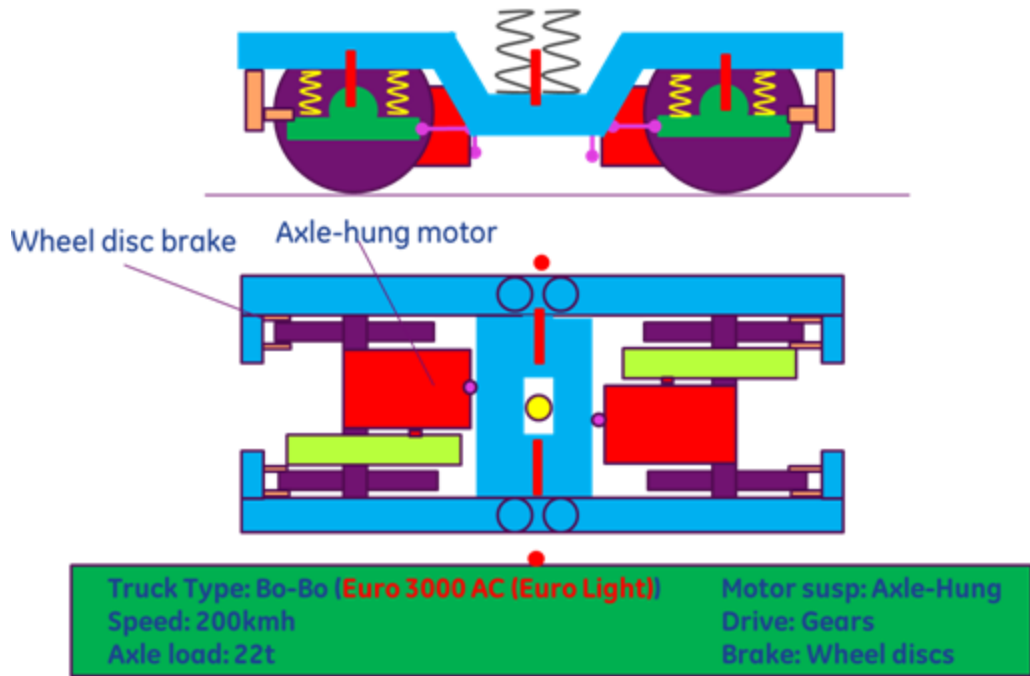

Figure C.1g: Vossloh Truck with Axle-Hung Motor

## Appendix D. Task Modeling Results

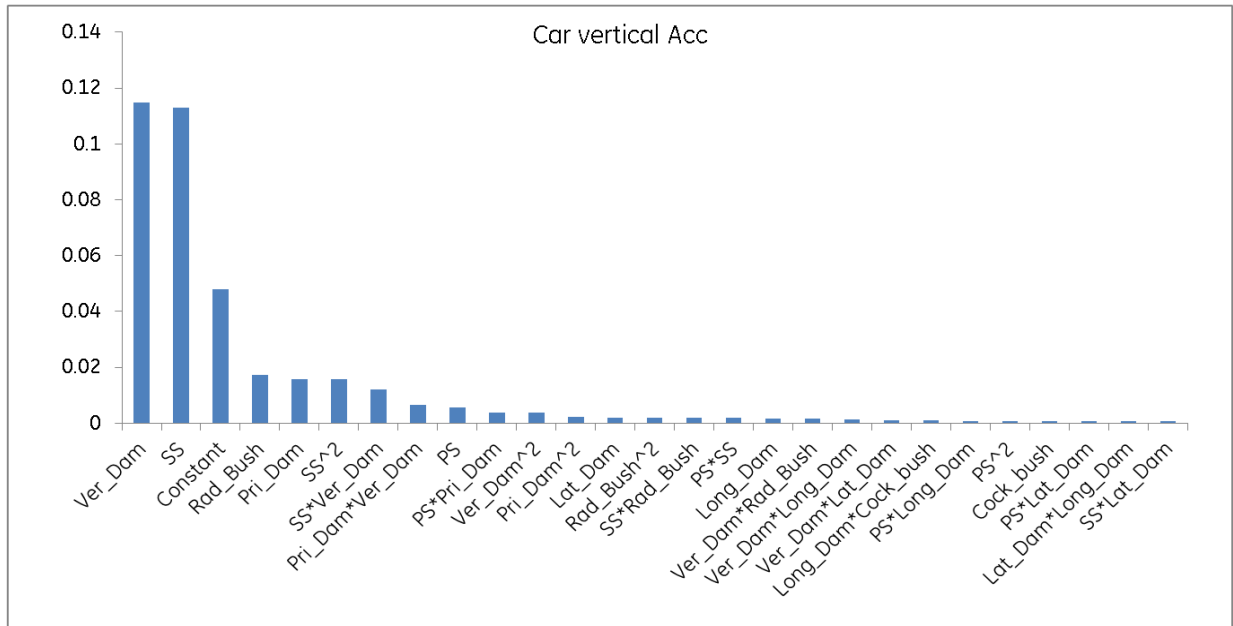

Figure D.1a: Pareto plot

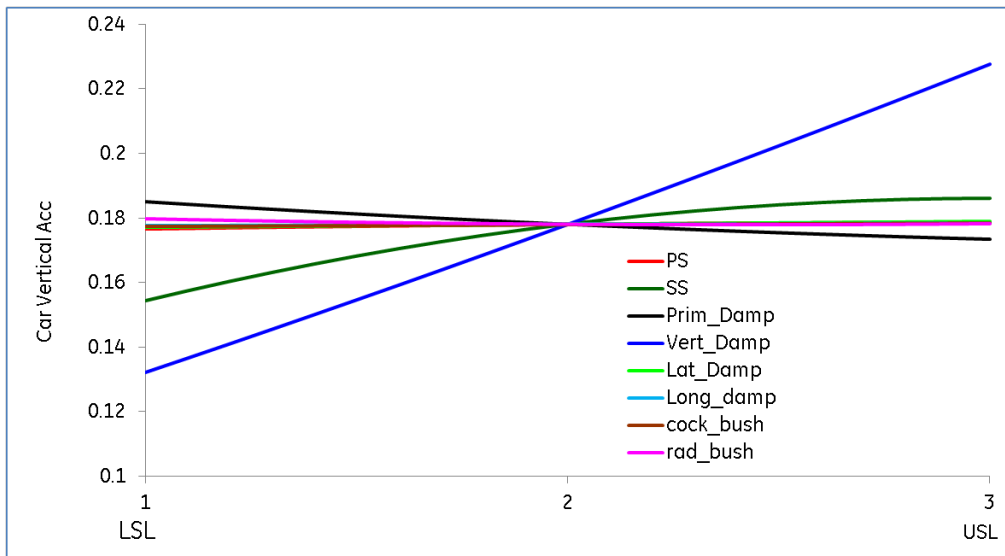

Figure D.1b: Sensitivity plot

Figure D.1b—Vertical car body acceleration in  $m/s^2$  (Frame-hung motor, new wheel and worn rail profiles, straight track, Class 7, 125 mph)

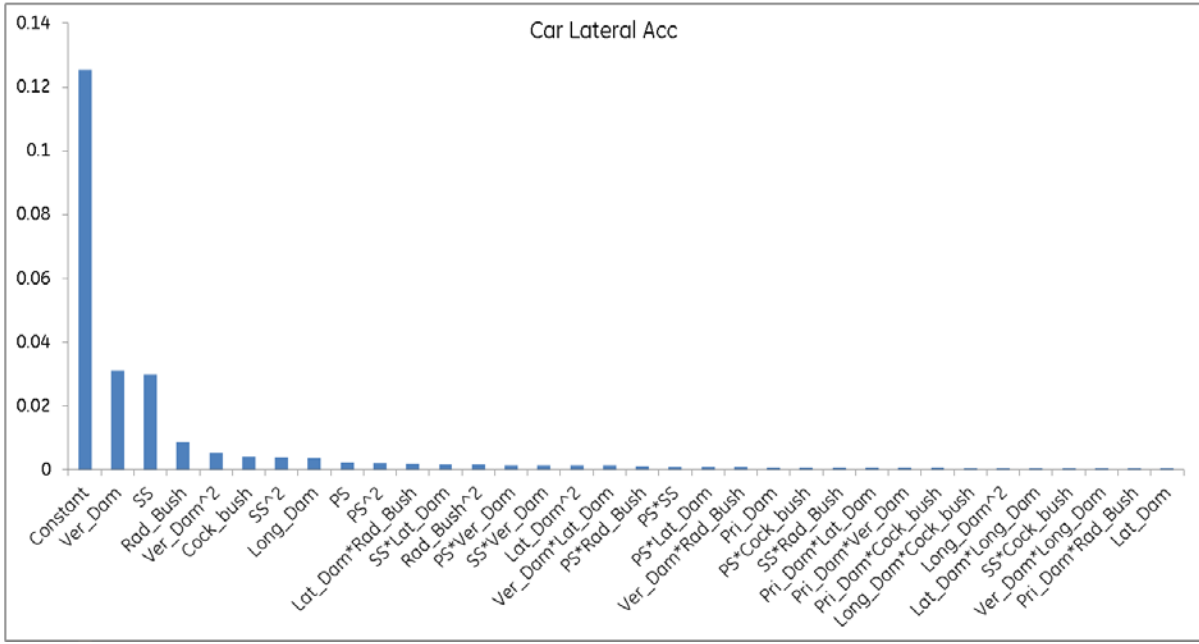

Figure D.1c: Pareto plot

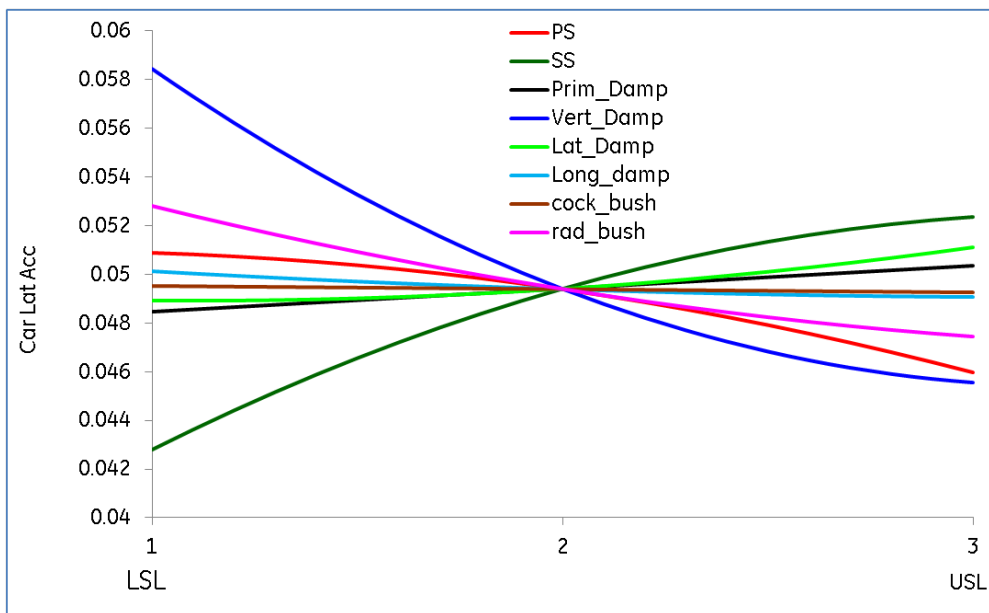
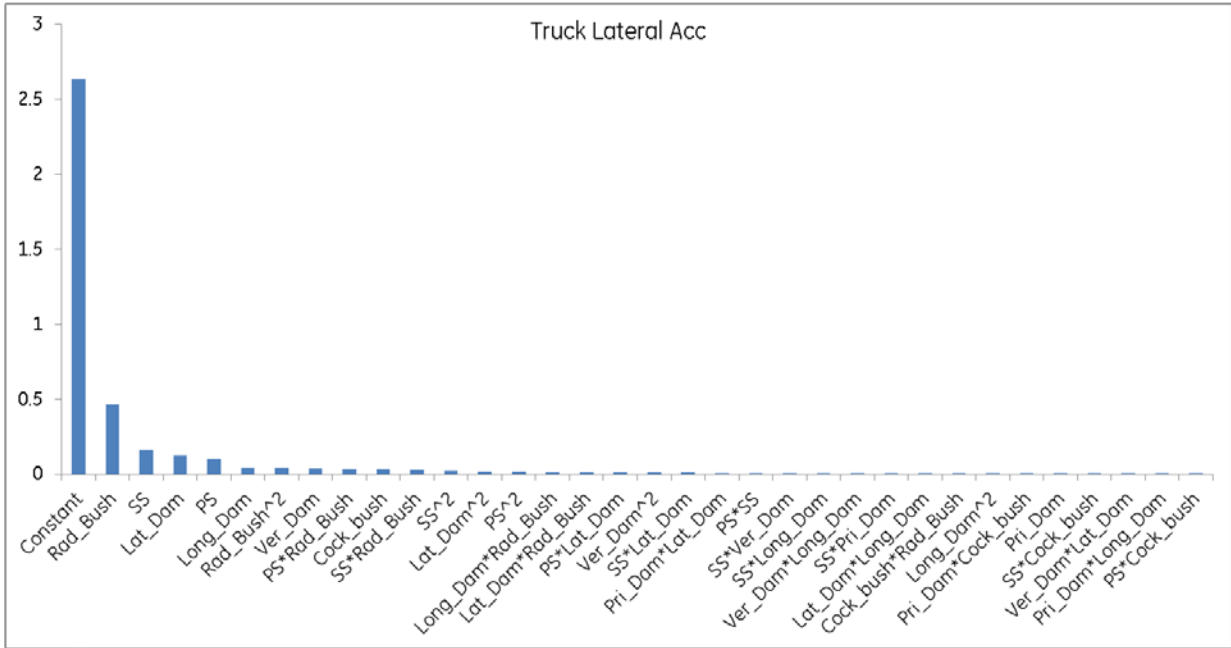
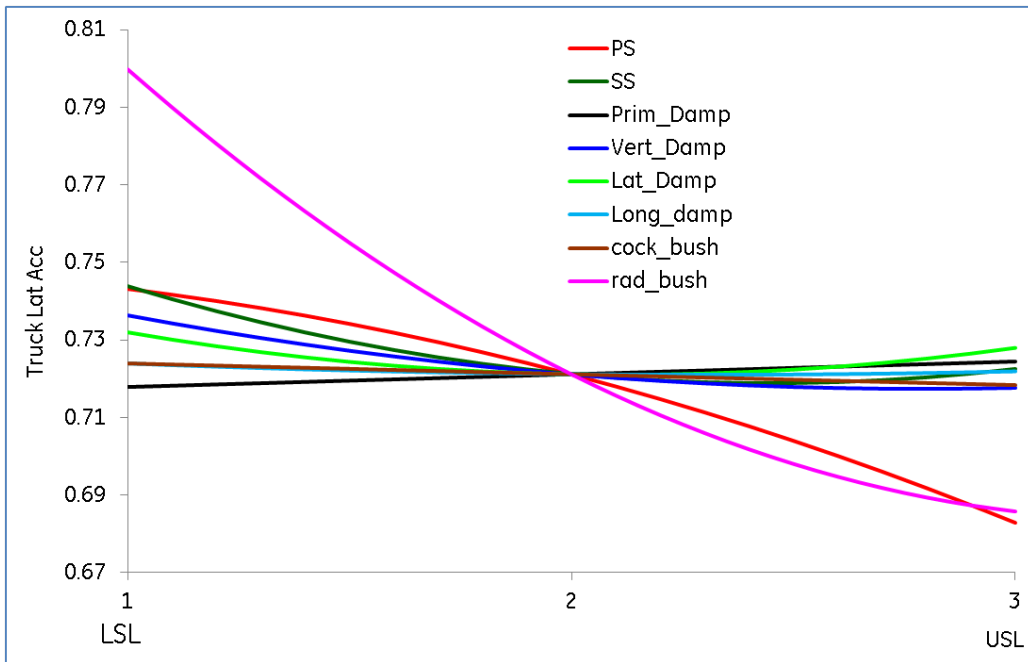

Figure D.1d: Sensitivity Plot

Figure D.1d—Lateral car body acceleration in  $m/s^2$  (Frame-hung motor, new wheel and worn rail profiles, straight track, Class 7, 125 mph)

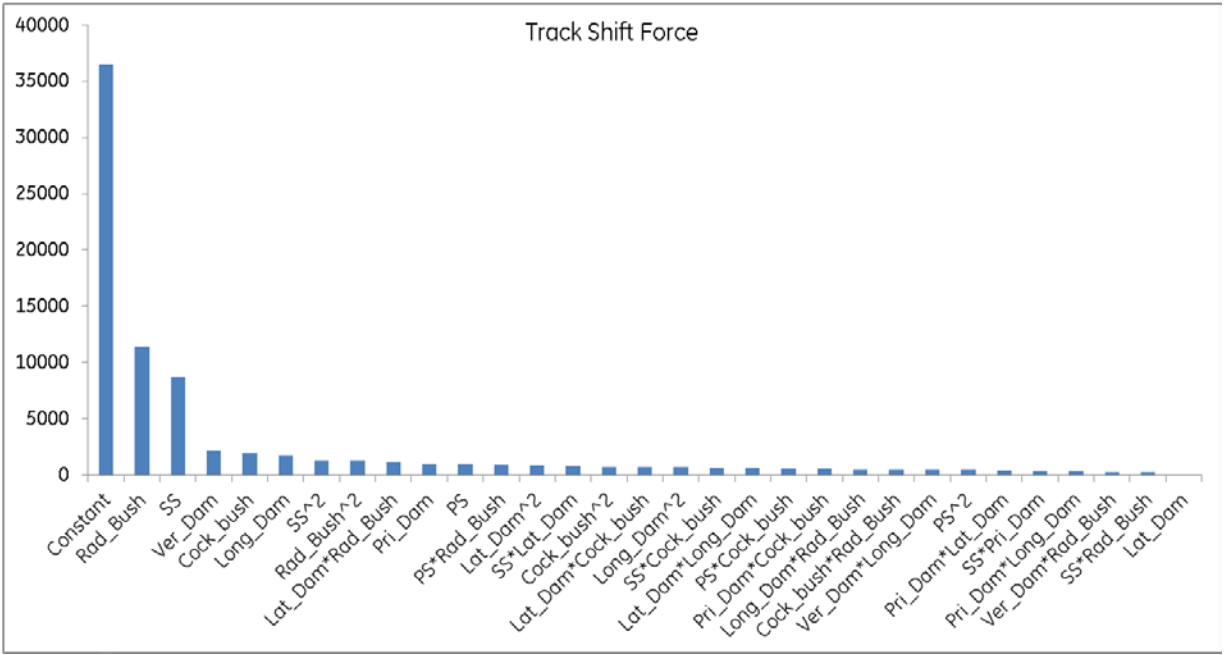

**Figure D.1e: Pareto plot**

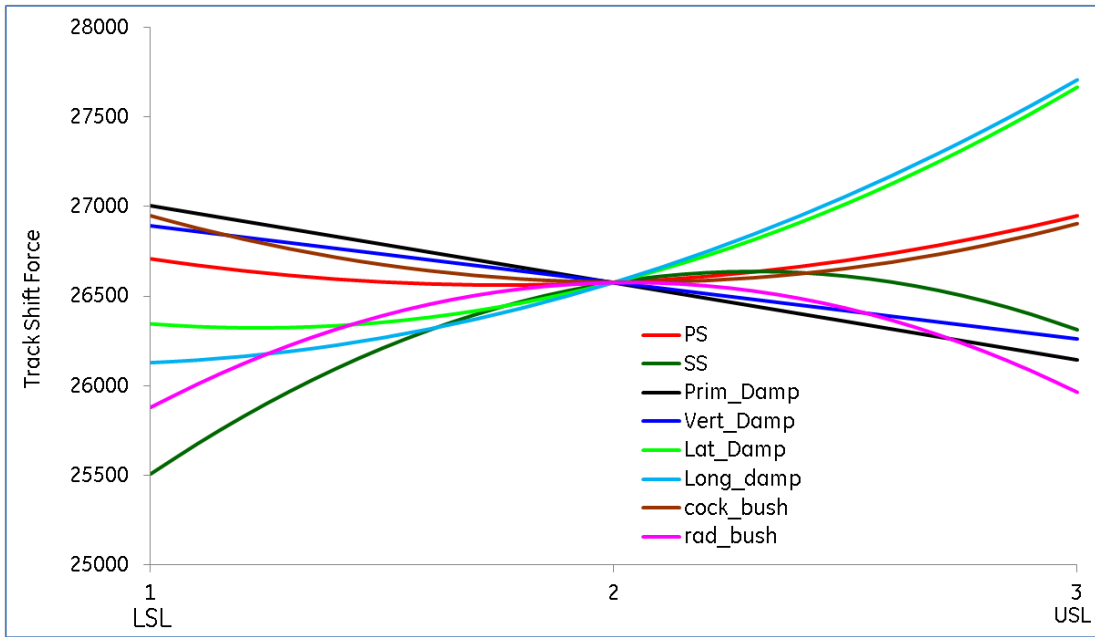

**Figure D.1f: Sensitivity Plot**

Figure D.1f—Lateral truck acceleration in  $m/s^2$  (Frame-hung motor, new wheel and worn rail profiles, straight track, Class 7, 125 mph)



**Figure D.1g: Pareto plot**



**Figure D.1h: Sensitivity Plot**

Figure D.1h—Track shift force in N (Frame-hung motor, new wheel and worn rail profiles, straight track, Class 7, 125 mph)



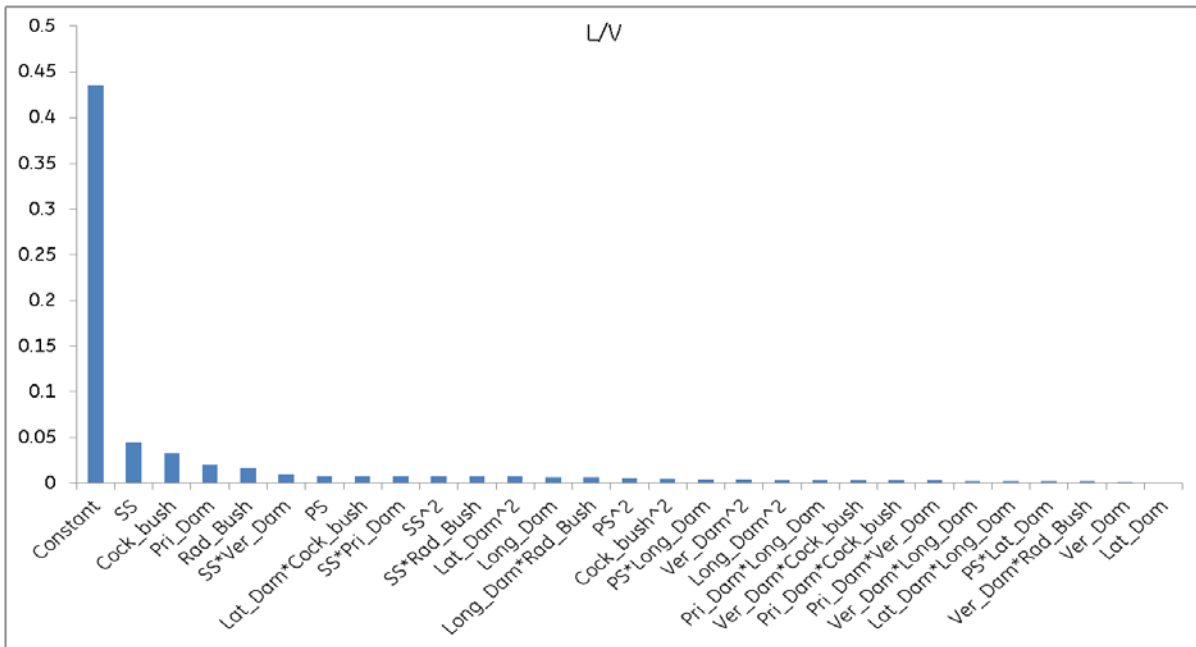

Figure D.1i: Pareto plot

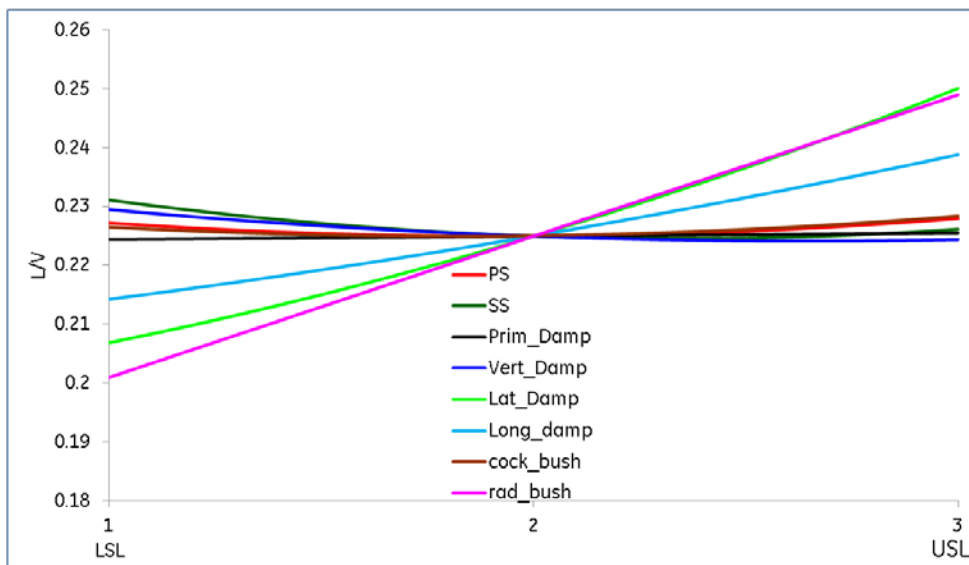
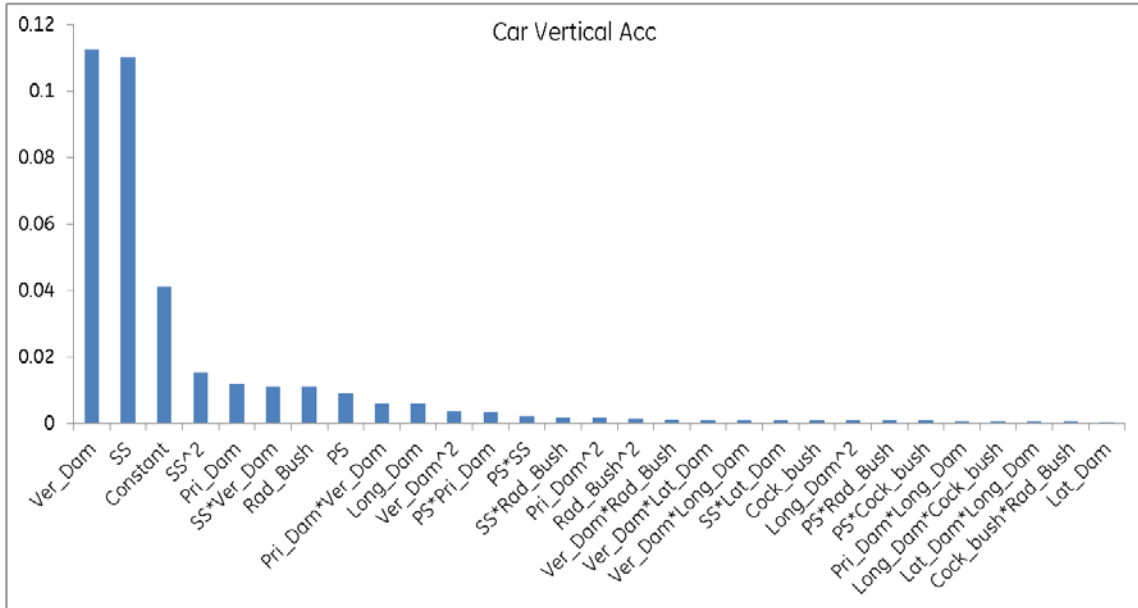
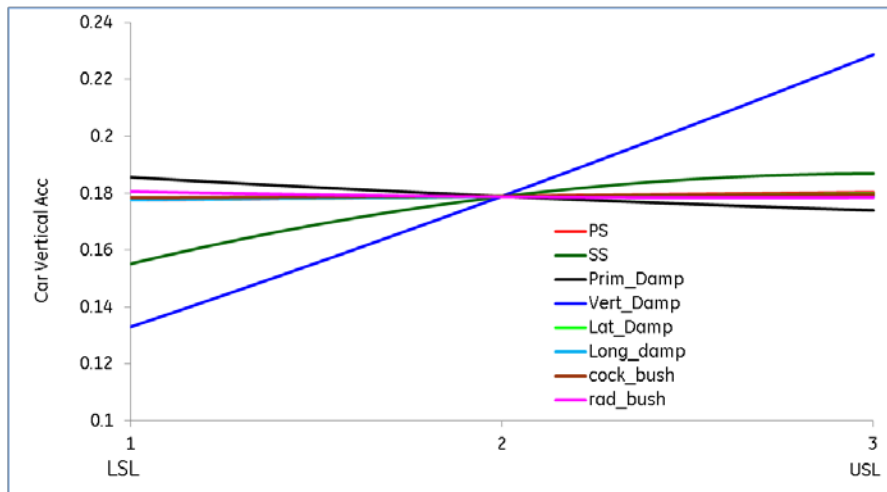

Figure D.1j: Sensitivity Plot

Figure D.1j—Wheel L/V (Frame-hung motor, new wheel and worn rail profiles, straight track, Class 7, 125 mph)

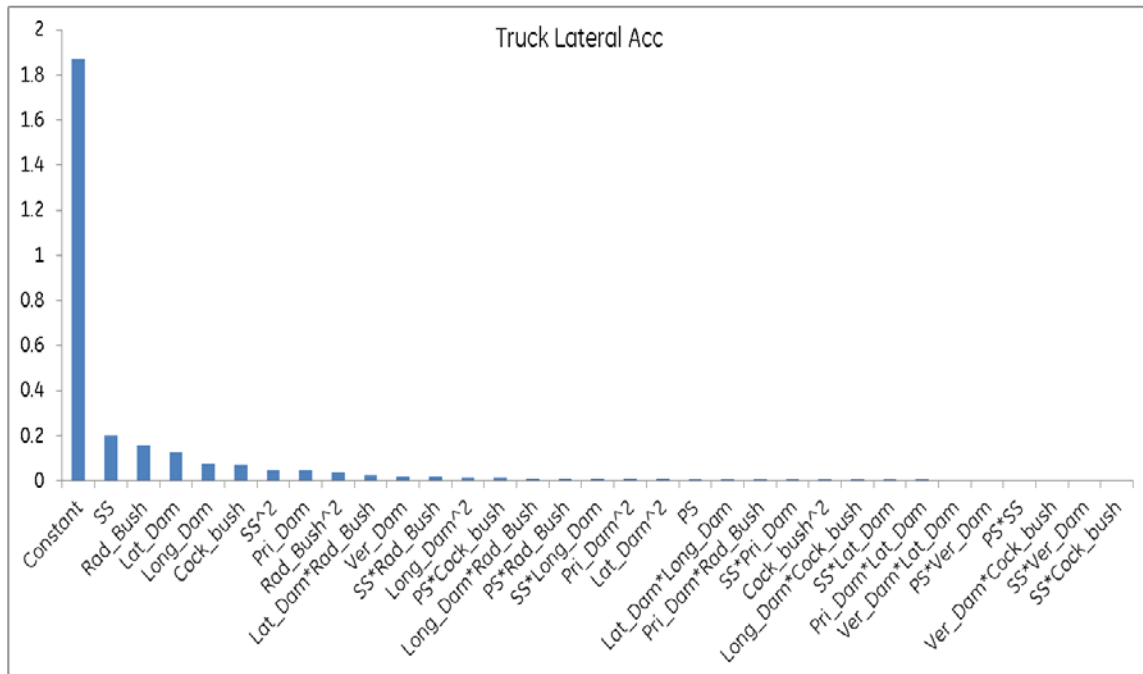

**Figure D.1k: Pareto plot**

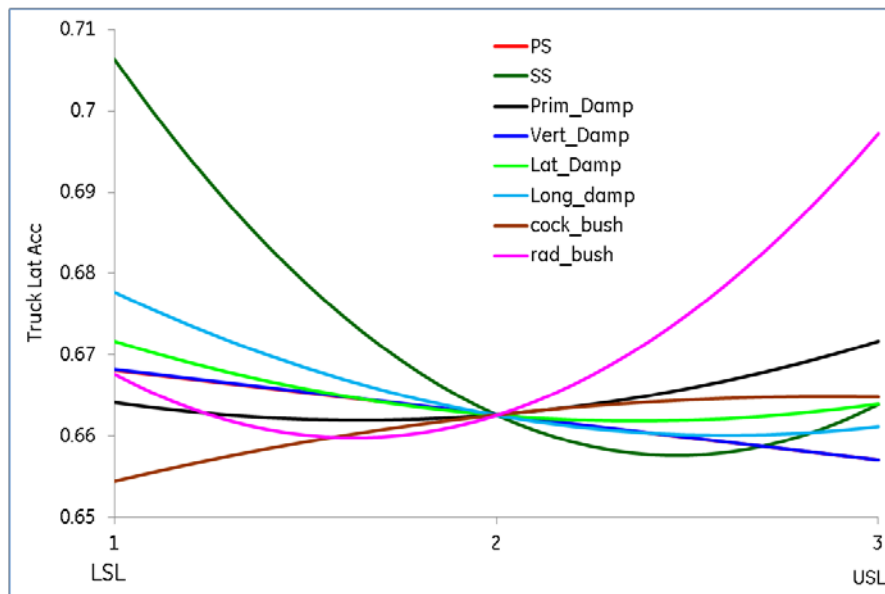

**Figure D.1l: Sensitivity Plot**

Figure D.1l—Vertical car body acceleration in  $m/s^2$  (Frame-hung motor, new wheel and worn rail profiles, 1.1 degree curve, 6” superelevation, Class 7 track, 125 mph)

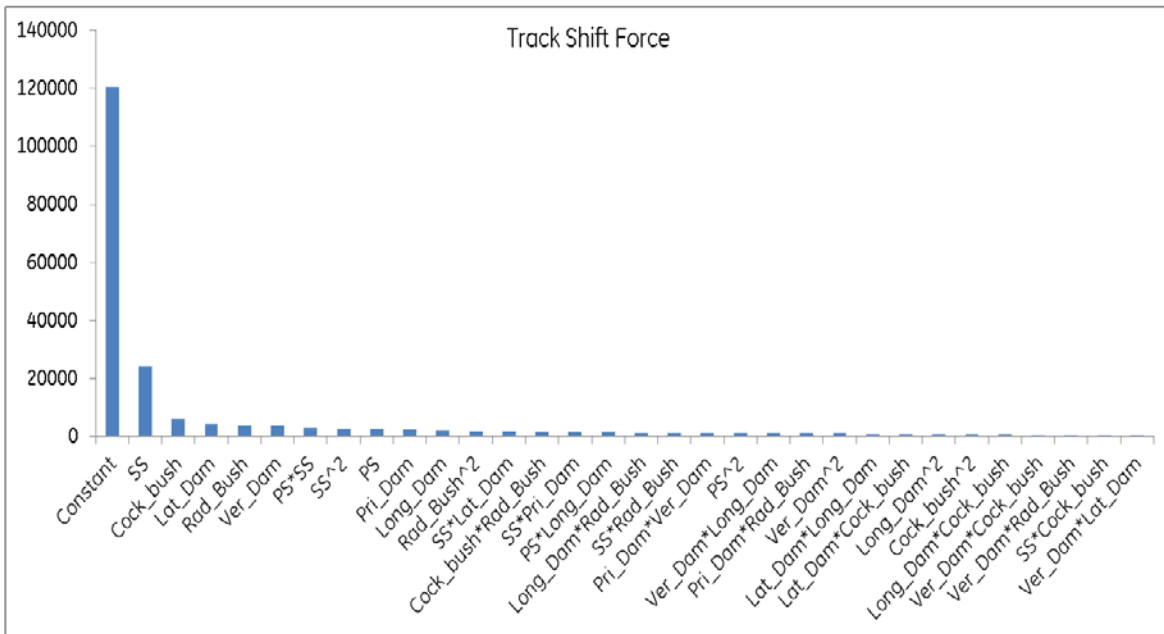

**Figure D.1m: Pareto plot**

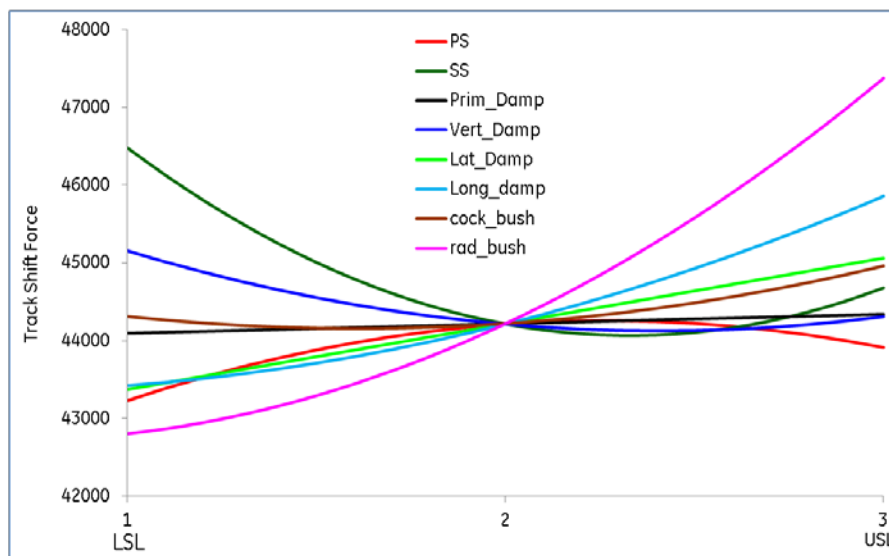

**Figure D.1n: Sensitivity plot**

Figure D.1n—Lateral truck acceleration in  $m/s^2$  (Frame-hung motor, new wheel and worn rail profiles, 1.1 degree curve, 6" superelevation, Class 7 track, 125 mph)

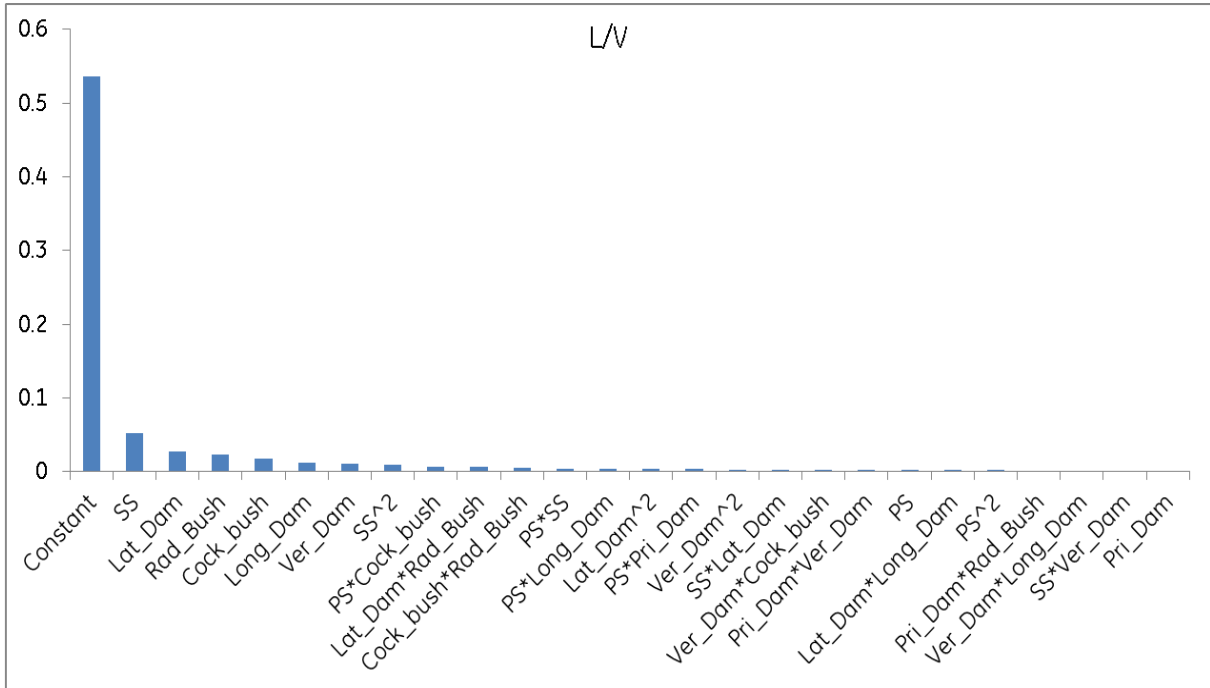

**Figure D.1o: Pareto plot**

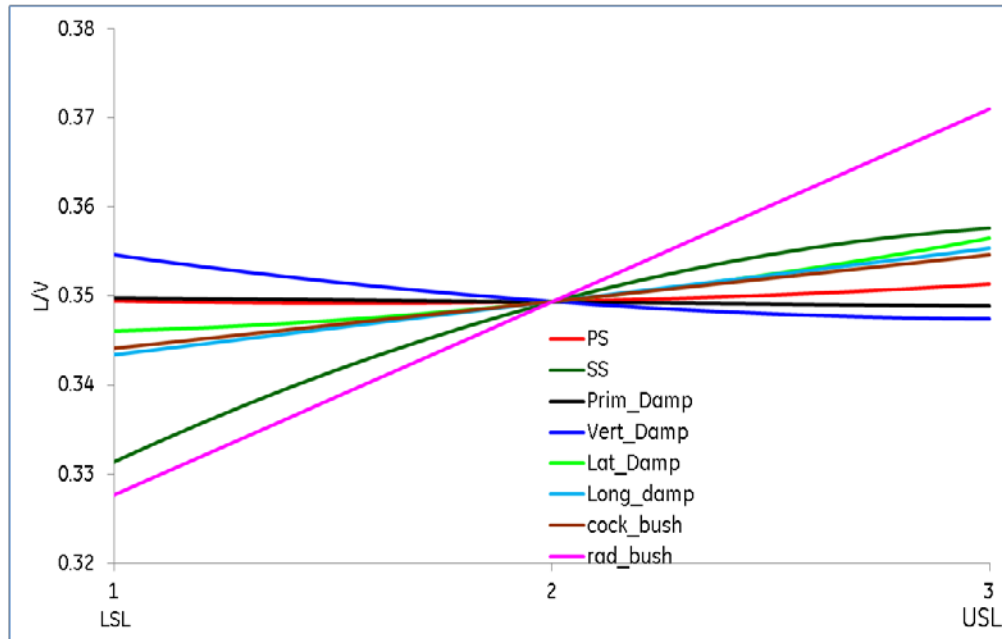

**Figure D.1p: Sensitivity plot**

Figure D.1p—Track shift force in N (Frame-hung motor, new wheel and worn rail profiles, 1.1 degree curve, 6” superelevation, Class 7 track, 125 mph)



**Figure D.1q: Pareto plot**



**Figure D.1r: Sensitivity plot**

Figure D.1r—Wheel L/V (Frame-hung motor, new wheel and worn rail profiles, 1.1 degree curve, 6" superelevation, Class 7 track, 125 mph)

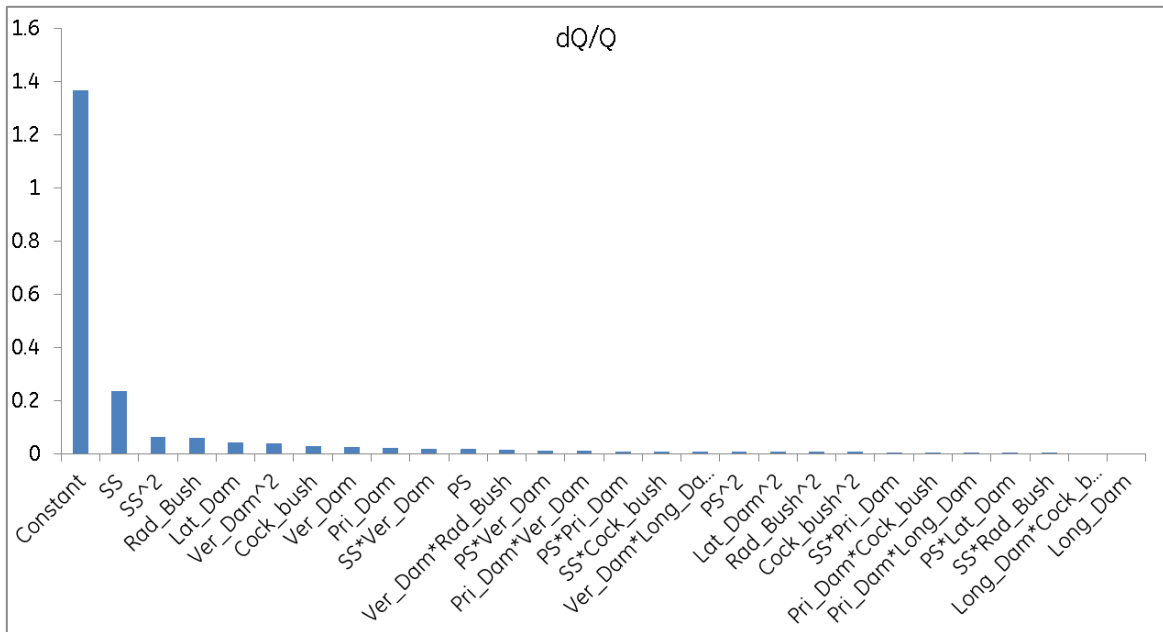

Figure D.1s: Pareto plot

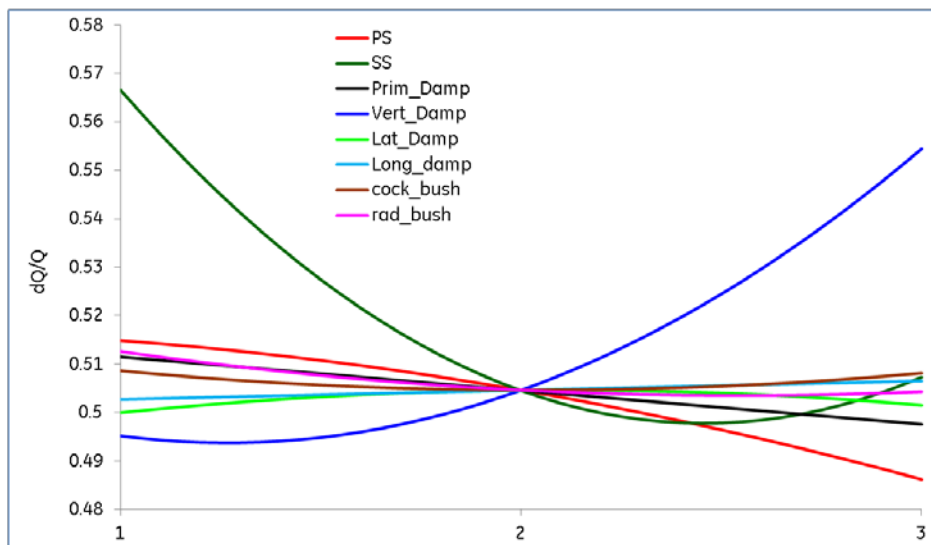

Figure D.1t: Sensitivity plot

Figure D.1t—Wheel load reduction rate (Frame-hung motor, new wheel and worn rail profiles, 1.1 degree curve, 6” superelevation, Class 7 track, 125 mph)

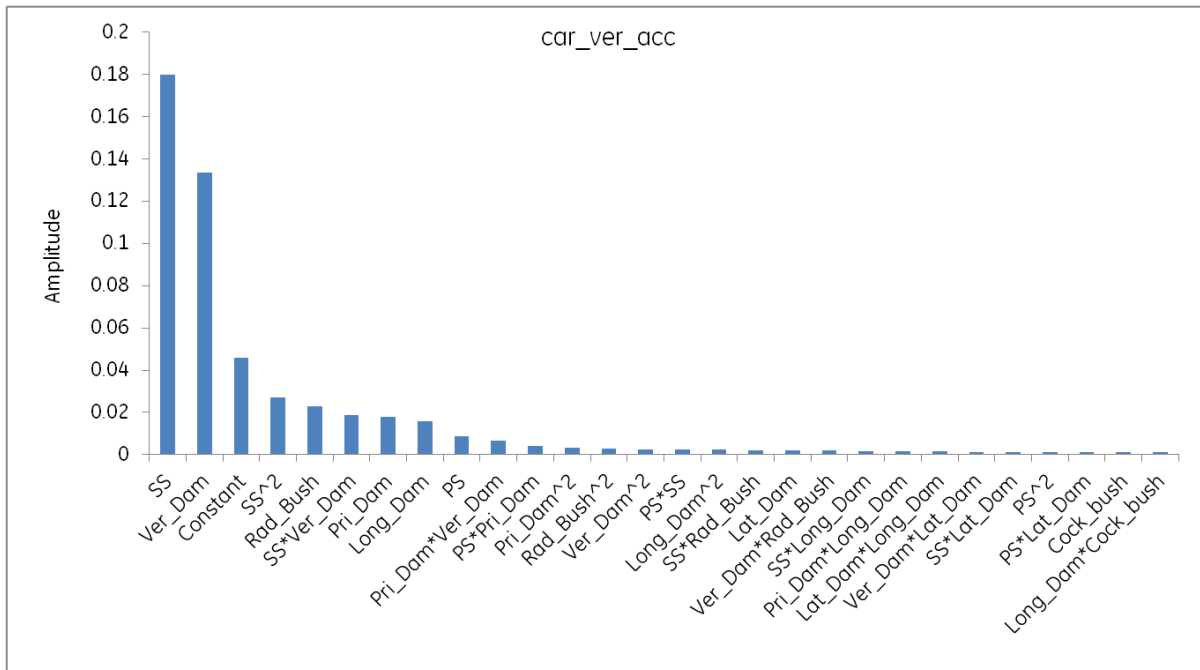

Figure D.1s: Pareto plot

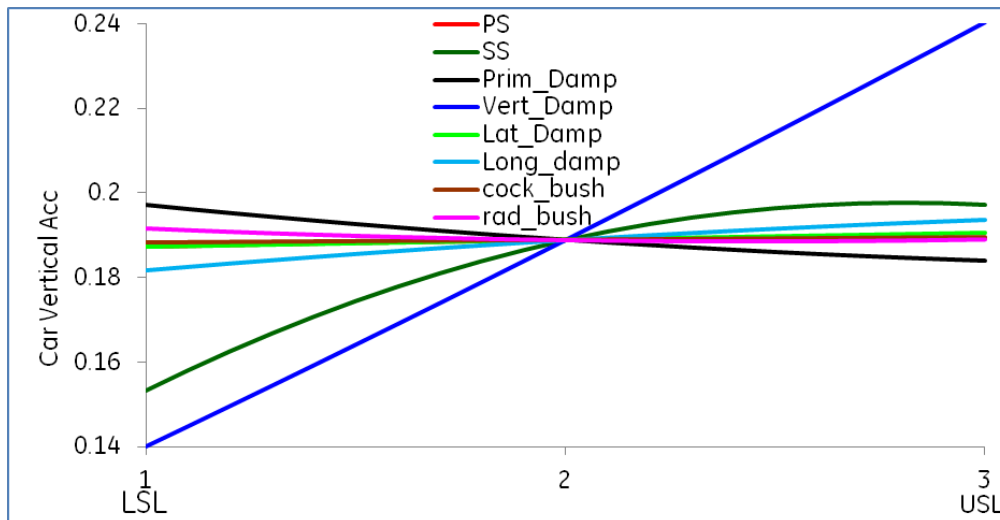
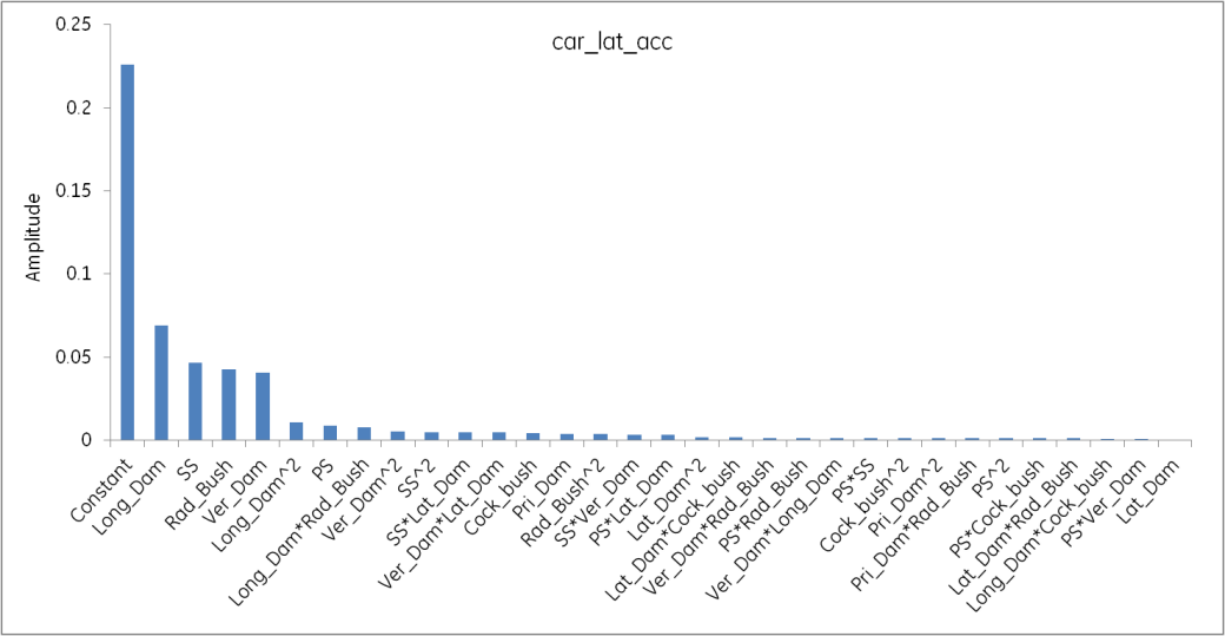
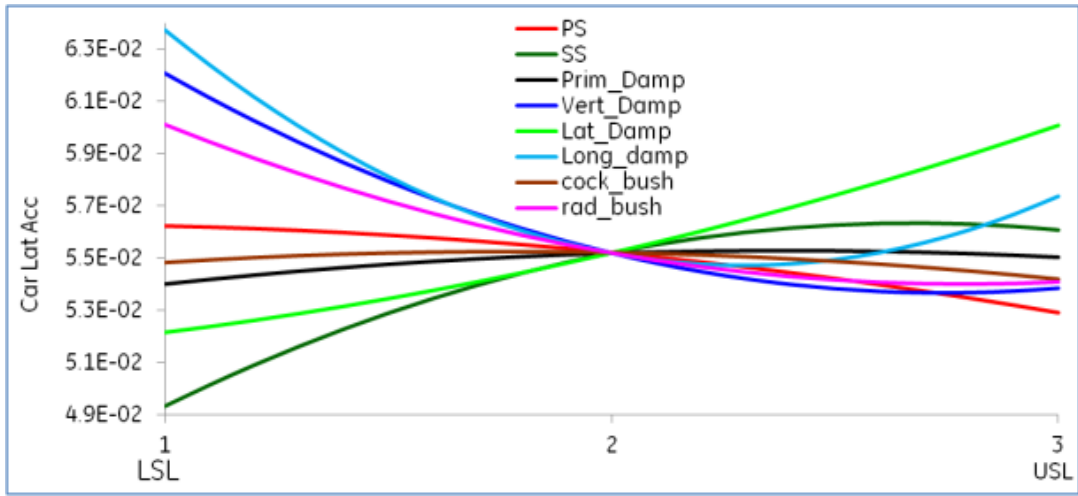

Figure D.1t: Sensitivity plot

Figure D.1t—Pareto and sensitivity of vertical car body acceleration in  $m/s^2$  (Frame-hung motor, worn wheel and worn rail profiles, straight track, Class 7, 125 mph)



**Figure D.1u: Pareto plot**



**Figure D.1v: Sensitivity plot**

Figure D.1v—Lateral car body acceleration in m/s<sup>2</sup> (Frame-hung motor, worn wheel and worn rail profiles, straight track, Class 7, 125 mph)



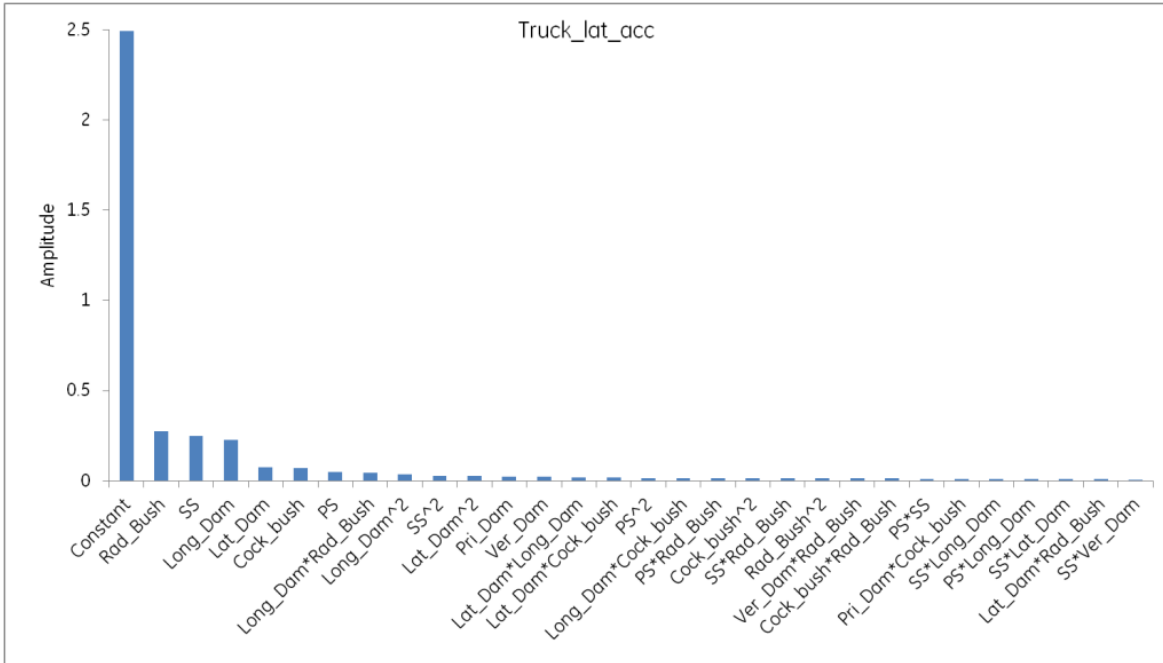

**Figure D.1w: Pareto plot**

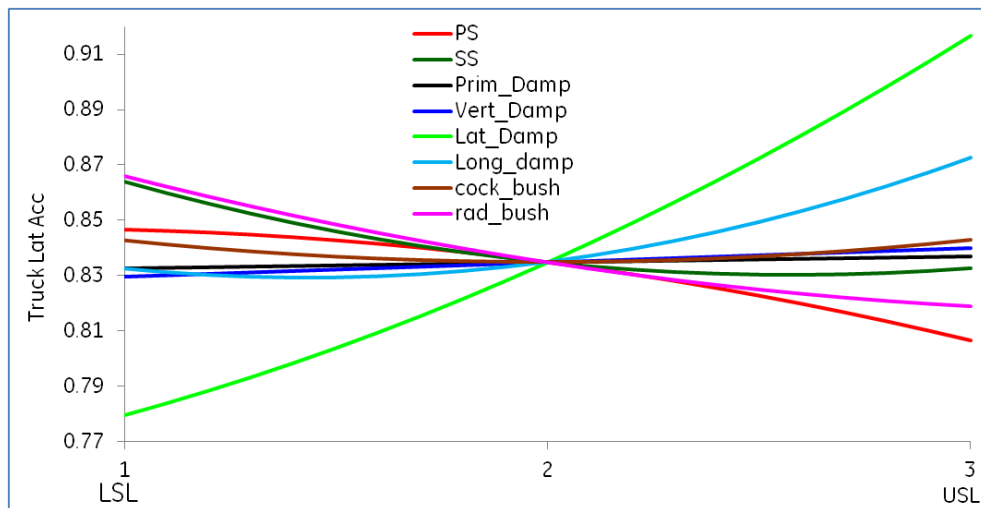

**Figure D.1x: Sensitivity plot**

Figure D.1x—Lateral truck acceleration in  $m/s^2$  (Frame-hung motor, worn wheel and worn rail profiles, straight track, Class 7, 125 mph)

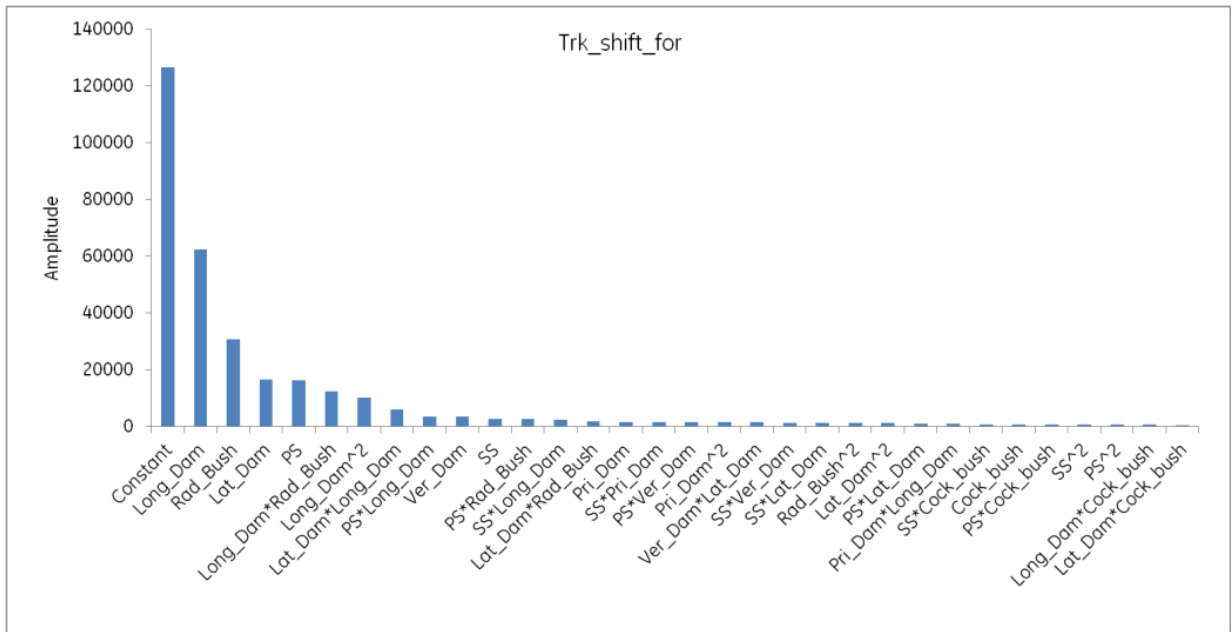

Figure D.1y: Pareto plot

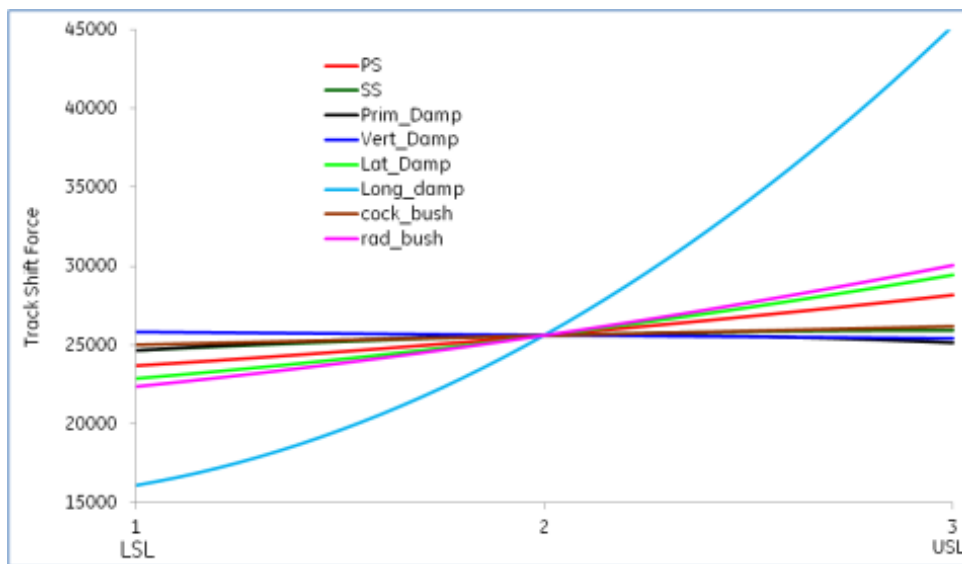
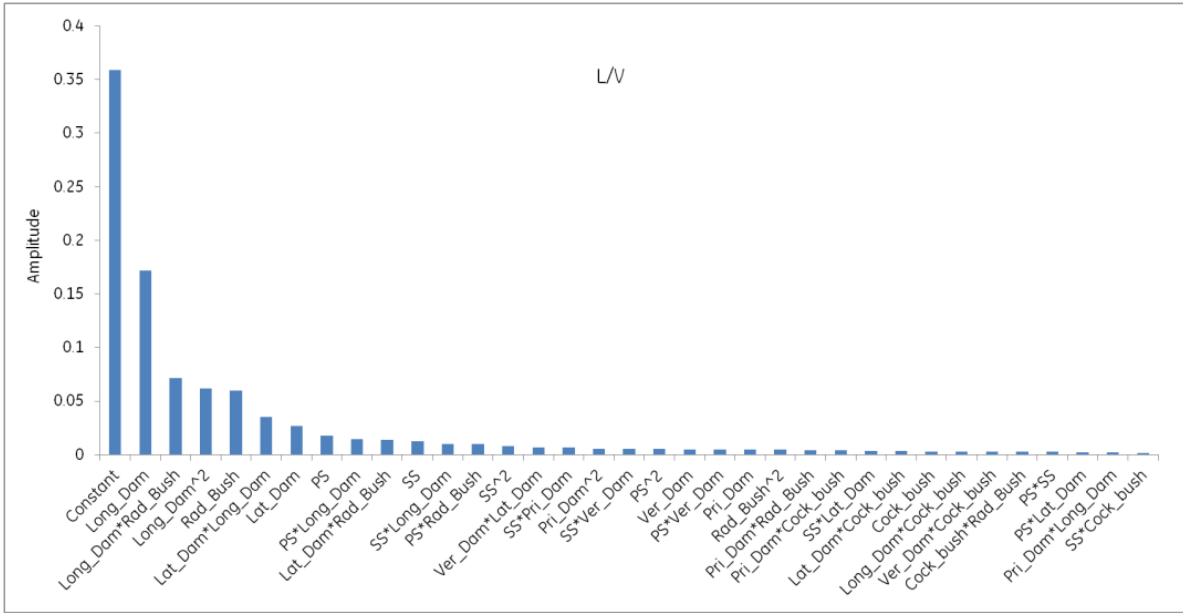
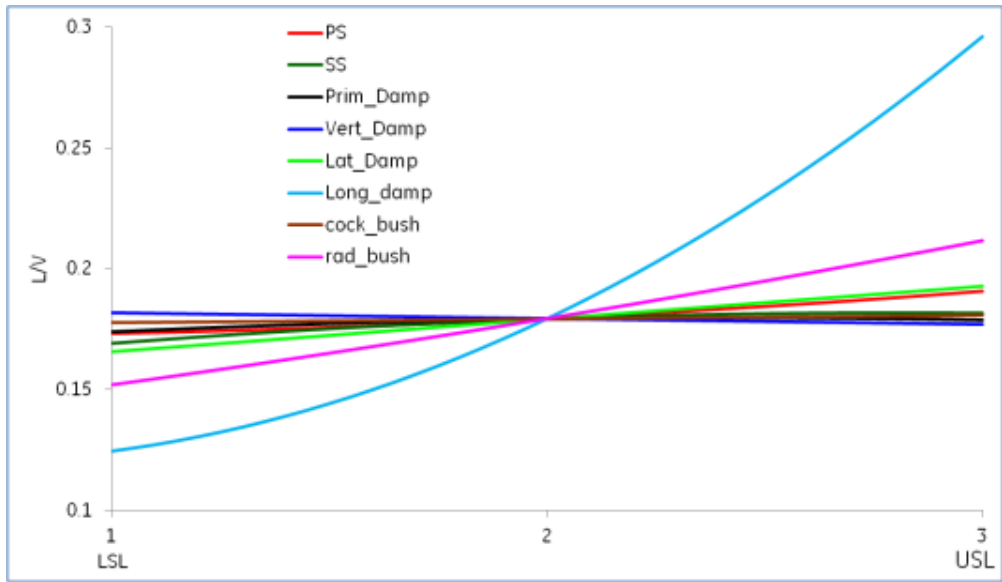

Figure D.1z: Sensitivity plot

Figure D.1z—Track shift force in N (Frame-hung motor, worn wheel and worn rail profiles, straight track, Class 7, 125 mph)



**Figure D.1aa: Pareto plot**



**Figure D.1ab: Sensitivity plot**

Figure D.1ab—Wheel L/V (Frame-hung motor, worn wheel and worn rail profiles, straight track, Class 7, 125 mph)

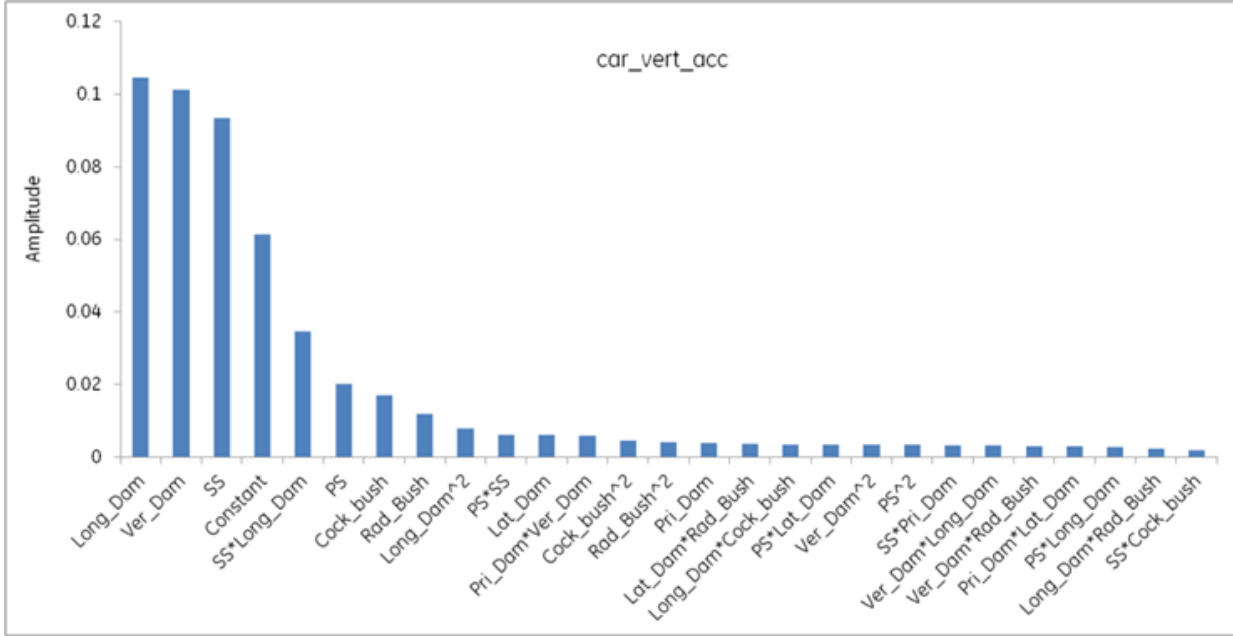

Figure D.1ac: Pareto plot

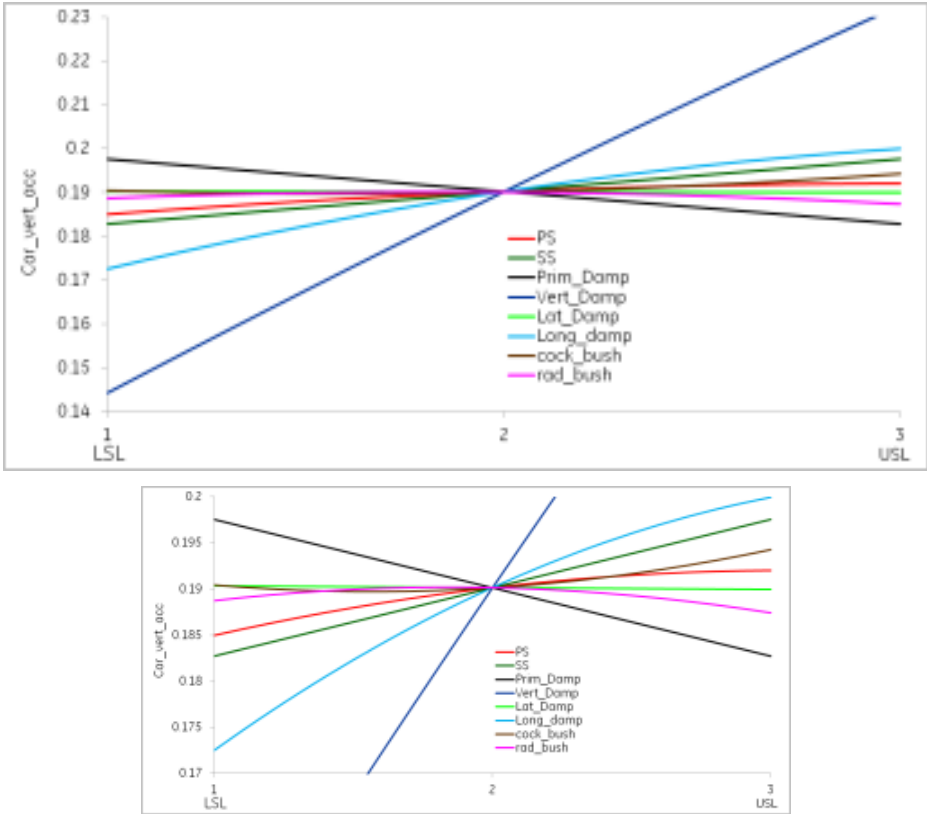

Figure D.1ad: Sensitivity plot

Figure D.1ad—Vertical car body acceleration in  $m/s^2$  (Frame-hung motor, worn wheel and worn rail profiles, 1.1 degree curve, 6" superelevation, Class 7 track, 125 mph)

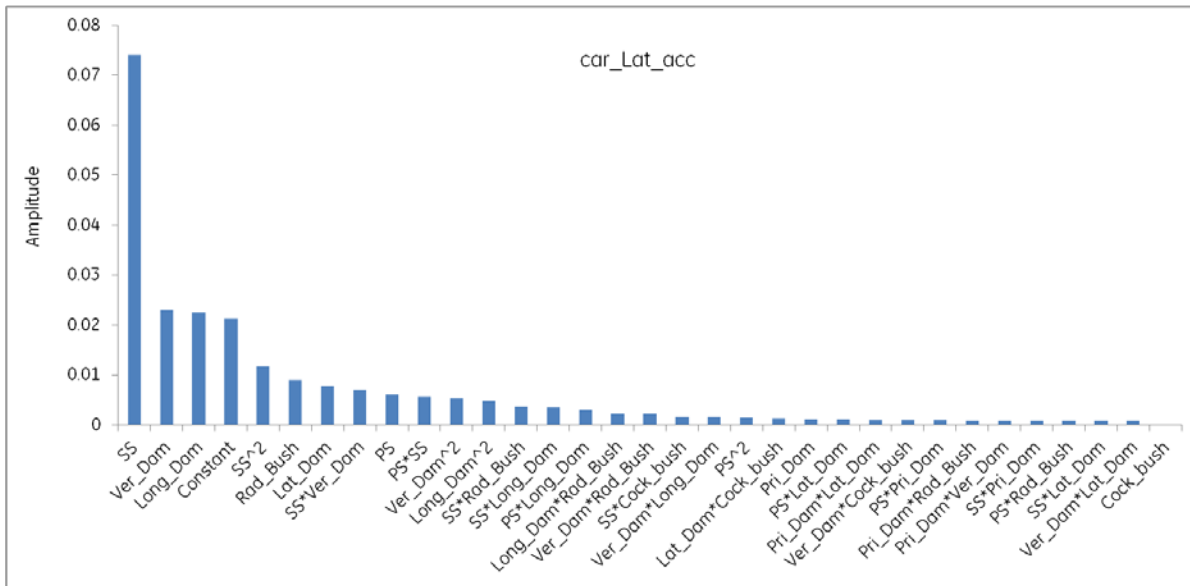

Figure D.1ae: Pareto plot

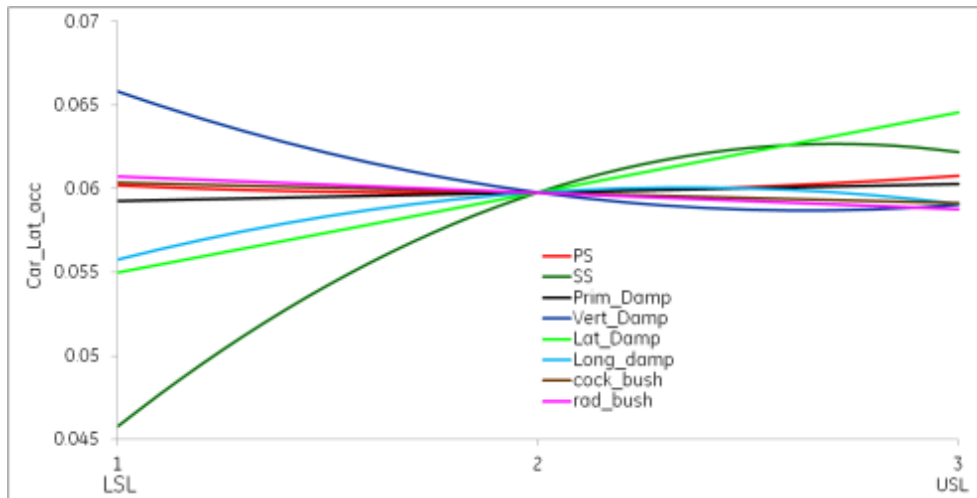

Figure D.1af: Sensitivity plot

Figure D.1af—Lateral car body acceleration in  $m/s^2$  (Frame-hung motor, worn wheel and worn rail profiles, 1.1 degree curve, 6" superelevation, Class 7 track, 125 mph)

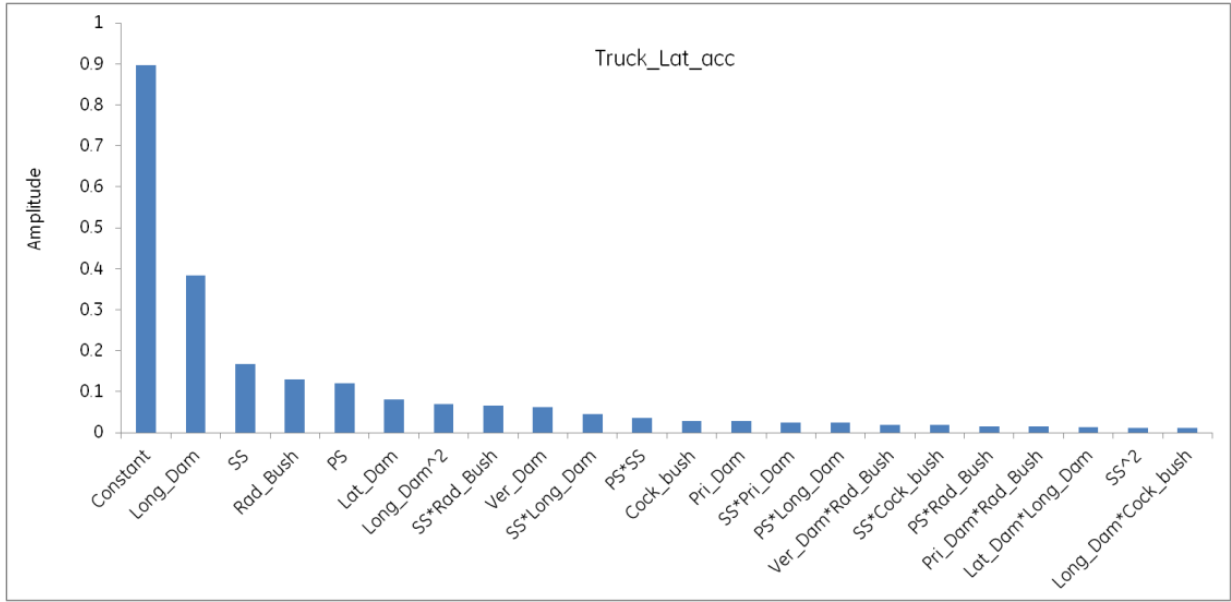

Figure D.1ag: Pareto plot

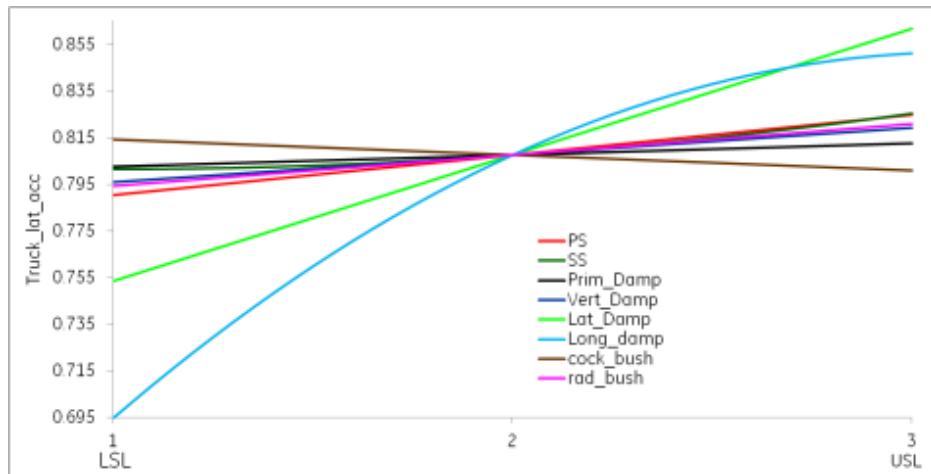
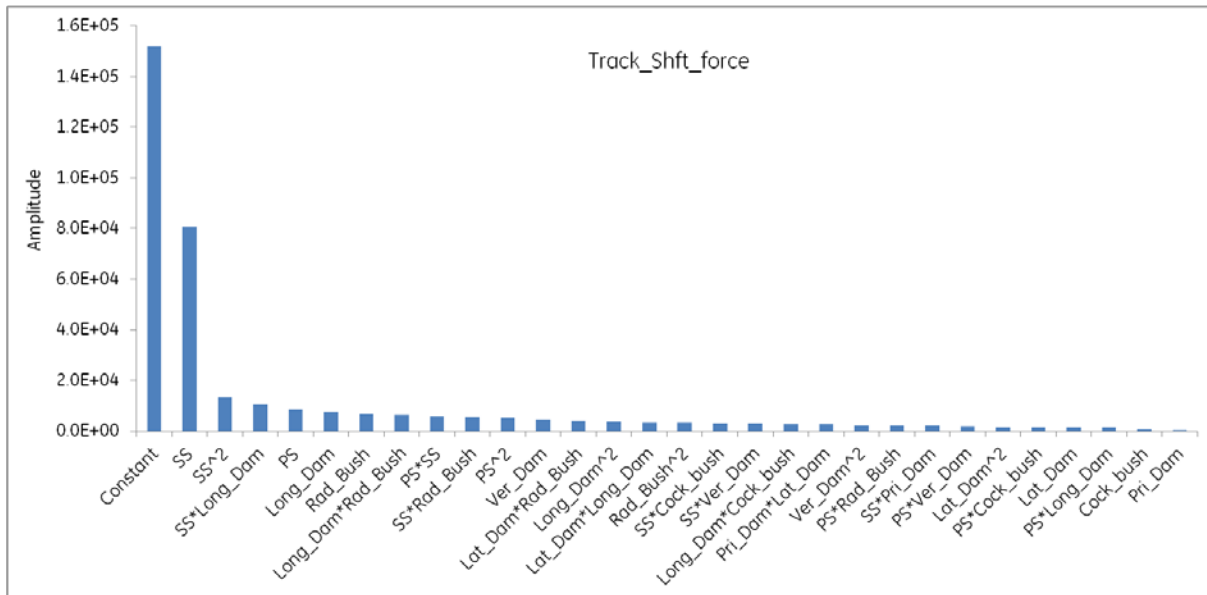
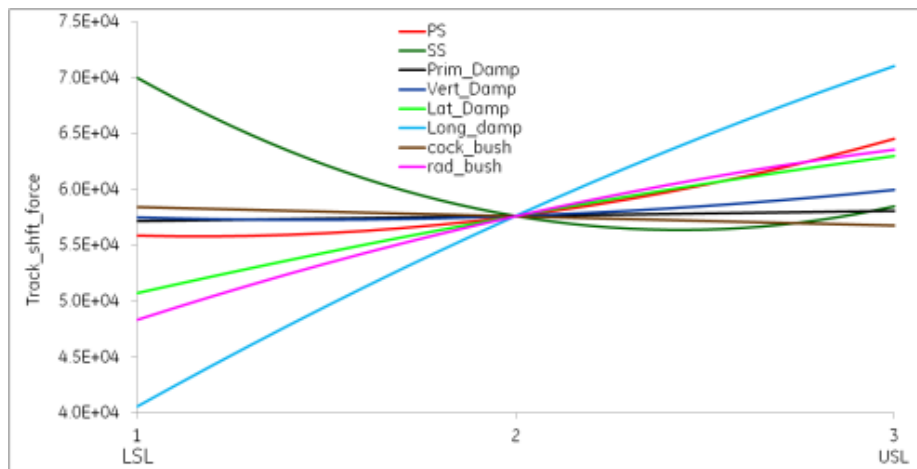

Figure D.1ah: Sensitivity plot

Figure D.1h—Lateral truck acceleration in  $m/s^2$  (Frame-hung motor, worn wheel and worn rail profiles, 1.1 degree curve, 6" superelevation, Class 7 track, 125 mph)

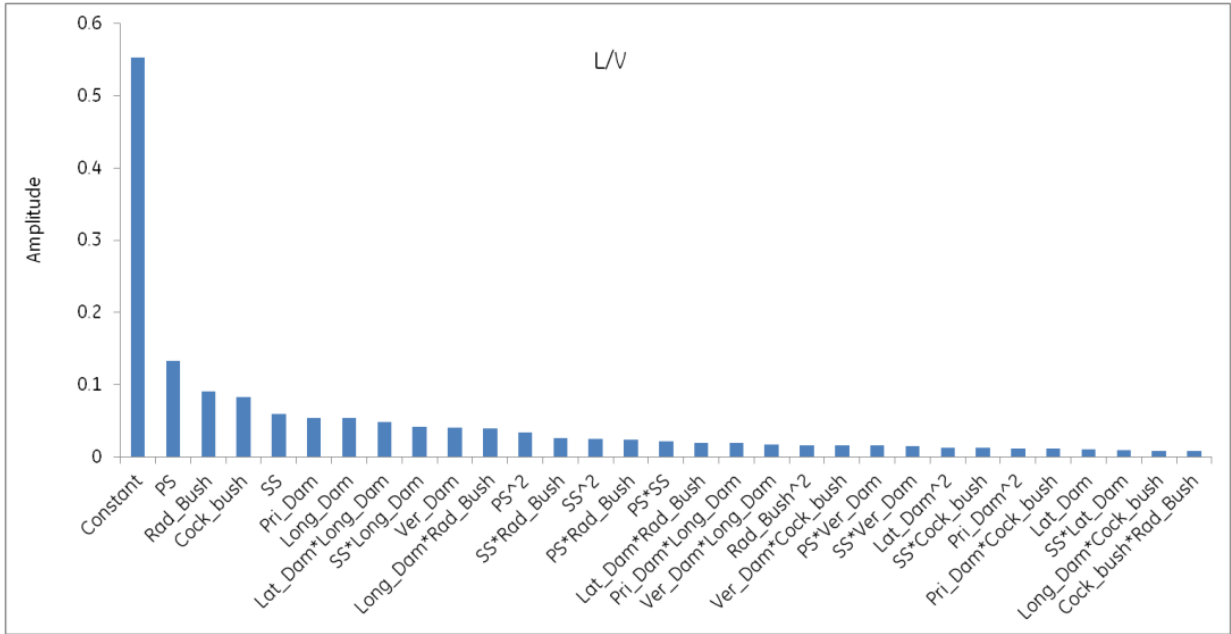

**Figure D.1ai: Pareto plot**

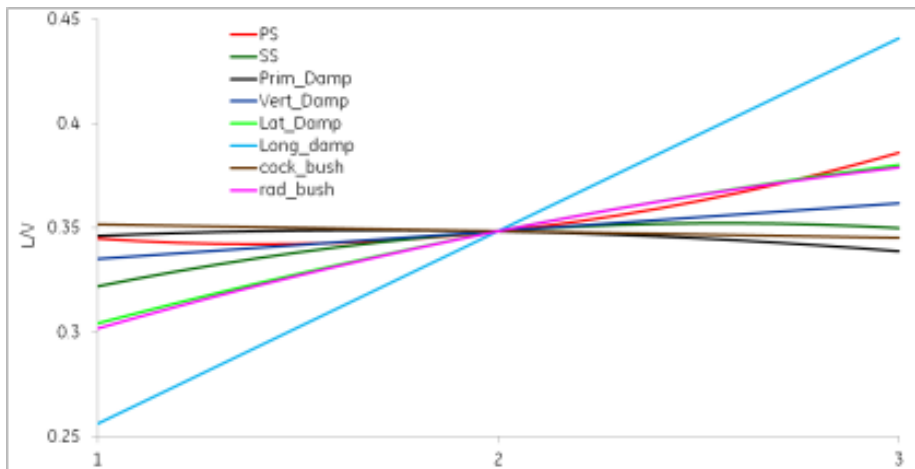

**Figure D.1aj: Sensitivity plot**

Figure D.1aj—Track shift force in N (Frame-hung motor, worn wheel and worn rail profiles, 1.1 degree curve, 6” superelevation, Class 7 track, 125 mph)



**Figure D.1ak: Pareto plot**



**Figure D.1al: Sensitivity plot**

Figure D.1al—Wheel L/V ( Frame-hung motor, worn wheel and worn rail profiles, 1.1 degree curve, 6” superelevation, Class 7 track, 125 mph)



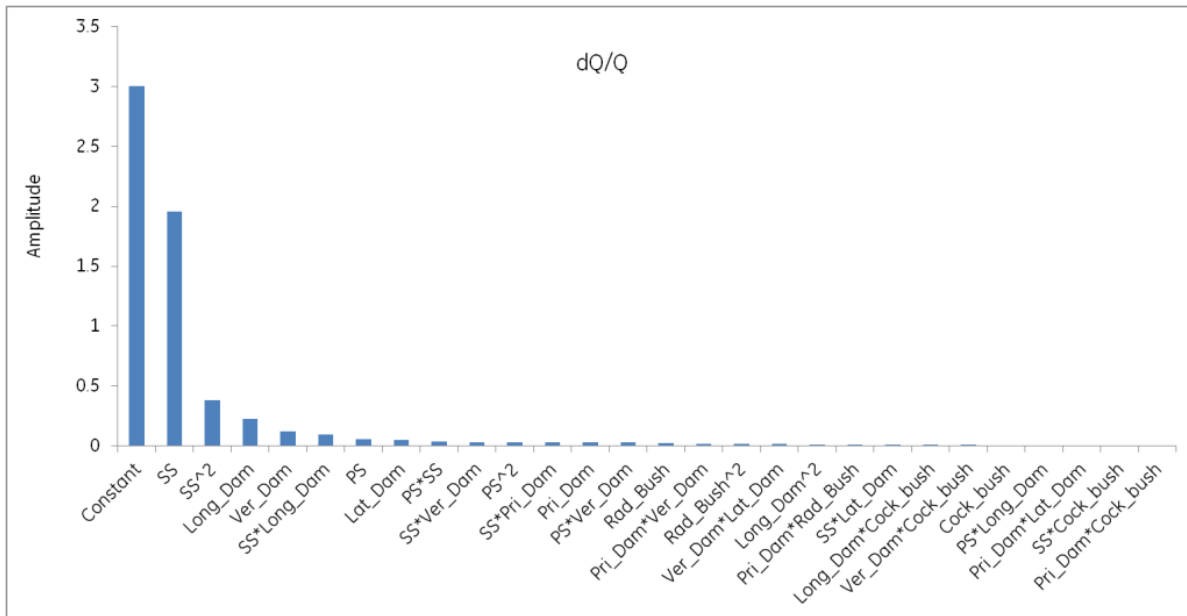

**Figure D.1am: Pareto plot**

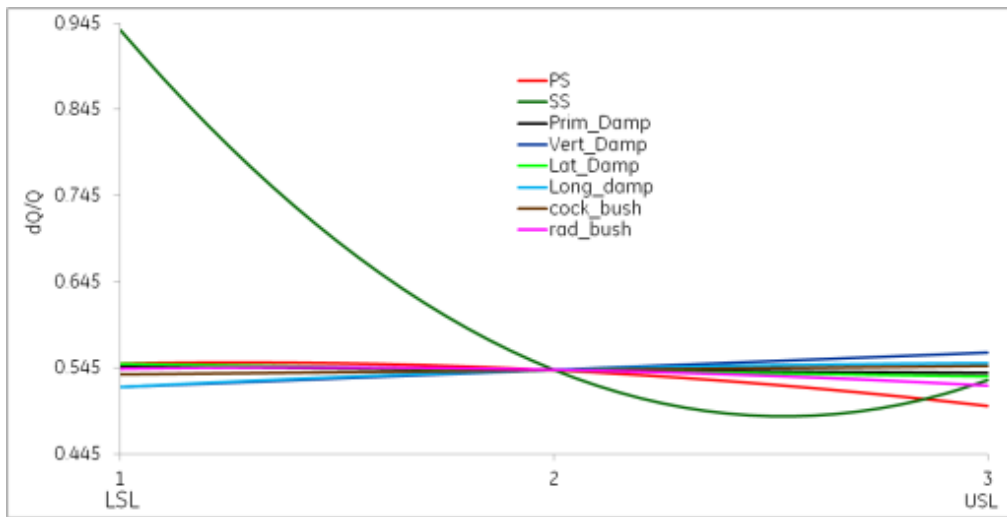

**Figure D.1an: Sensitivity plot**

Figure D.1an—Wheel load reduction rate (Frame-hung motor, worn wheel and worn rail profiles, 1.1 degree curve, 6” superelevation, Class 7 track, 125 mph)

## Abbreviations and Acronyms

---

AAR	Association of American Railroads
Bo-Bo	A locomotive with two bogies, each bogie having two powered axles
CCD	Central Composite Design
CFR	Code of Federal Regulations
DB	Dynamic Brake
DFSS	Design for Six Sigma
DMU	Diesel Multiple Unit
DOE	Design of Experiments
EMU	Electric Multiple Unit
EN	European
FMEA	Failure Modes and Effects Analysis
FRA	Federal Railroad Administration
GET	GE Transportation
HSR	High-Speed Rail
kph	Kilometers per Hour
lbf	Pounds Force
MBTA	Massachusetts Bay Transit Authority
MCAT	Minimally Compliant Analytical Track
mph	Miles per Hour
MPI	Motive Power Inc.
MT	Metric Tons (1 metric ton = 2,204.6 lbf)
NJT	New Jersey Transit
PRIIA	Passenger Rail Investment and Improvement Act
RCF	Rolling Contact Fatigue